

REVIEW OF COMPRESSED SNOW MECHANICS: TESTING METHODS

Mohit Nitin Shenvi^{*a}, Corina Sandu^a, Costin Untaroiu^b

^a *Terramechanics, Multibody, and Vehicle Systems (TMVS) Laboratory
Department of Mechanical Engineering, Virginia Tech, Blacksburg, VA, United States*

^b *Center for Injury Biomechanics (CIB) Laboratory
Department of Biomedical Engineering & Mechanics, Virginia Tech, Blacksburg, VA, United States*
mshenvi@vt.edu, csandu@vt.edu, costin@vt.edu

* Corresponding Author

This is the Author's Accepted Manuscript (AAM) of:

Shenvi, M. N., Sandu, C., and Untaroiu, C.. "Review of compressed snow mechanics: Testing methods." *Journal of Terramechanics*, Volume 100, April 2022, Pages 25-37, <https://doi.org/10.1016/j.jterra.2021.11.006>

Abstract

Snow is a complex material that is difficult to characterize especially due to its high compressibility and temperature-sensitive nonlinear viscoelasticity. Snow mechanics has been intensively investigated by avalanche and army researchers for decades. However, fewer research studies were published for the compacted snow, defined as snow with a density in a range of 370-560 kg/m³. This review focuses on the various testing methods that are used especially to characterize the behavior of compacted snow under compressive and shear loading. The working principles, inherent assumptions, and advantages/disadvantages of the devices are summarized. In addition, some of the important material properties of snow like density, elastic modulus, etc., and their measurement is highlighted. Lastly, a correlation of the testing methods to commonly used approaches in modeling snow is presented. Overall, we believe that this study can help to better understand the existing test data related to compacted snow and guide future testing in this field.

Keywords: compacted snow, snow testing, snow material properties, snow material models

Nomenclature					
p	Pressure	[Pa]	k_c	Cohesion constant	[kN/m ⁽ⁿ⁺¹⁾]
k_ϕ	Friction angle constant	[kN/m ⁽ⁿ⁺²⁾]	b	Width of contact patch	[m]
z	Sinkage	[m]	j	Shear Displacement	[m]
R	Penetration resistance	[N]	n	Number of blows	[]
W	Weight of hammer	[N]	h	Height of hammer drop	[m]
S_n	Sinkage after 'n' blows	[m]	Q	Weight of assembly	[N]
e	Coefficient of restitution	[]	τ	Shear stress	[N/m ²]
c	Cohesion modulus	[Pa]	ϕ	Internal friction angle	[rad]
q	Deviatoric Stress	[N/m ²]	E	Young's Modulus	[Pa]
ρ	Density	[kg/m ³]	σ_c	Unconfined compressive strength	[Pa]

1. Introduction

Snow mechanics has been a primary field of interest for researchers in several domains, like avalanche research, winter sports research, and transportation research. Avalanche research, as the name suggests, includes the study and forecast of avalanches in the mountainous snow covers and methodologies to prevent this phenomenon. Research in winter sports is primarily of concern for improving the safety and comfort of equipment like skis. Another major contributor to this effort is the mobility regime, which researches the effect of snow properties on the trafficability of the vehicle and it is the focus of this review. Initial efforts in the mobility domain began towards the latter half of the 20th century primarily for army vehicle mobility in the United States. Studies of the prior two areas could also provide insight into the mechanics of snow behavior as well as the material models developed for snow.

The tires are an important part of the vehicle which contribute to the motion generation of the vehicle with respect to the terrain. The tire-snow interaction is very important for passenger vehicle handling in winter conditions and affects the airplane performance on snow runways, as well. The testing of winter (specifically snow) performance of tires has primarily been outdoors. While snow properties are dependent on external factors, like temperature variation, snowfall, humidity change, etc., it is difficult to replicate the outdoor conditions in the laboratory, so fewer indoor studies exist ((Huang and Lee, 2013; Lee and Huang, 2015; Peinke et al., 2020)). The usage of numerical methods for the analysis of tire-snow interaction has seen a rise due to a variety of reasons, one of which is the reduction in costs due to experimentation. On the downside, some aspects of the snow behavior still lack understanding or lack the means to comprehensively model it.

Snow is a material having a microstructure that can be considered similar to foam (Kirchner et al., 2001) in its uncompressed condition. It exists in a multi-phase condition of the solid, liquid, and gaseous states (Carbone et al., 2010) as long as the pressure and temperature stay nearly constant. On the application of pressure (due to movement of vehicle or weight of overburden layer) or temperature change, or due to the metamorphosis (Fierz et al., 2009) of snow over time, this distribution of phases is bound to change. Also, the properties of snow are known to depend not only on the temperature but also on the strain rate ((Lawrence and Lang, 1981)). Thus, it can be concluded that the snow properties are dependent on various factors which include the temperature, pressure, rate of application of load, and humidity variations. A model to analyze the effects of the depth, the snow strength, the average contact pressure, and the density on the tire-snow interaction by quantifying the uncertainties using a polynomial chaos approach led to insights about the sensitivity of these parameters on the typical forces encountered by a tire (Li et al., 2009). The International Association for Cryospheric Sciences published a manual with important snow features and measurements of deposited snow that are used for classification of different types of snow (Fierz et al., 2009).

Snow density varies from the newly fallen snow ($70\text{-}150\text{ kg/m}^3$) up to the pure ice (917 kg/m^3) (Russell-Head and Budd, 1989). The main focus of this review is given to compressed snow for which density is in a range from 370 up to 560 kg/m^3 (Shoop et al., 2010). Section 2 presents the relevant material properties of compacted snow. Section 3 of this review details the various testing devices available for testing snow behavior in compression and shear before the failure theories and the correlation of these testing methods to the modeling approaches are presented in section 4. Section 5 discusses the conclusions from the various parts of this literature review.

2. Material properties of snow

Snow is considered to be a matrix dispersion of ice grains having some air pores and melted water (Sigrist, 2006). It can also be considered to be an open-cell type (sponge) of the cellular form of ice (Petrovic, 2003), however, the quoted studies in the work are not all in the compacted snow domain and hence the definition by (Sigrist, 2006) is a more generalized definition. Thus, the bonds between adjacent grains in the snow affect the mechanical properties of snow introducing variations in measurement. This formation of bonds is affected by several parameters. In addition, the measured properties of a test location are also affected by the rate of applied loading of the test device and thus it is difficult to quote a direct value for a specific property of snow. However, some properties of snow used for modeling purpose are more important and this section attempts to summarize these properties and their in-situ measurements.

2.1 Density

The density of snow can be considered a fundamental property as the mechanical properties of snow are linked to the density ((Schneebeli and Johnson, 1998; Wang and Baker, 2013)). The density of snow is a variable parameter (Domine, 2011) that ranges from as little as 10 kg/m^3 for fresh snow and up to 600 kg/m^3 for snowpack. Theoretically, the maximum density of snow can reach up to 900 kg/m^3 (ice density). The compacted snow that can be faced by vehicles is commonly categorized to have a density between 370 to 560 kg/m^3 (Shoop et al., 2010), albeit the vehicle trafficability studies rarely reach the upper end of this range.

Snow density is generally measured in the field by using cutters of known volume to collect samples, which are then weighed to find the density. A study (Proksch et al., 2016) on the precision of various cutters and their comparison with the micro-computed tomography (μCT) technique concluded that the density cutters lead to overestimation of density in the lower density range whereas they tend to underestimate the density in the higher density range. The μCT technique involves the reconstruction of snow on a microstructural level at the millimeter scale which is advantageous to the gravimetric methods (cutters) that have a resolution of the centimeter scale (Proksch et al., 2016). The threshold between lower and higher densities for this distinction was found to be a value ranging between 295 kg/m^3 to 350 kg/m^3 . In comparison with the μCT technique, the cylindrical density cutters were the most accurate (Proksch et al., 2016) as shown in Table 1. Newer techniques like the use of near-infrared waves to find the density of snow have been developed (Gergely et al., 2010) but not found to be commonly used in testing. A method to estimate the density of snow from the penetration hardness resistance values of the Snow MicroPenetrometer (section 3.1.3)(SMP) was devised, too (Kaur and Satyawali,

2017). The recent approaches have better accuracy in snow density estimation but are also costlier in comparison to the traditional method of using cutters, so if the density variation of a maximum of 5% is acceptable, using the density cutters seems appropriate.

Table 1

Comparison of different cutters for density estimation (Adapted from (Proksch et al., 2016))

Type of cutter	R ²	Threshold value of density (kg/m ³)	Overestimation of low densities in percentage	Underestimation of low densities in percentage
Box type	0.89	350	4	2
Wedge type	0.93	310	6	6
Cylindrical type	0.95	296	1	1

2.2 Elastic modulus of snow

The data for snow characterization in the literature mostly consists of Young's modulus (E) of snow as the other moduli can be calculated if the Poisson's ratio is known, depending on the assumption of snow behavior i.e. elastic, viscoelastic, etc. In one of the earliest works on the topic (Mellor, 1975), an approximately linear correlation between the density (up to 600 kg/m³) and Young's modulus was found. The measured data is presented in bands as the effect of other parameters like temperature and microstructure cannot be directly quantified and thus same densities may present different values of Young's modulus. The usage of dynamic measurement methods (Schweizer and Camponovo, 2002) led to the conclusion that the static methods tend to underestimate the values as they account for not only the elastic but also the viscous part of deformation.

The elastic modulus of snow is measured in laboratory conditions (Gerling et al., 2017), by using a compression test as the snow tensile strength is much lower. The variability in Young's modulus and its dependence on the procedure and strain rate of testing is evident as for a density range of 100-350 kg/m³, Young's modulus was estimated to vary between 0.2 and 20 MPa, by use of low strain rates (Mellor, 1975). On the other hand, the use of a dynamic loading approach (Sigrist, 2006) led to the finding that for a range of density between 210-360 kg/m³, the Young's modulus range was found to be between 20 and 70 MPa. The wave propagation approach followed (in (Gerling et al., 2017)) led to the validation of the acoustic pulse transmission method of Young's modulus estimation in comparison to the μ CT, while also finding that the SMP tends to underestimate values of Young's modulus, as shown in Figure 1. The relation between density and elastic modulus is commonly found to have an exponential fit and eqn. (1) shows results from one such fit (Köhle and Schneebeli, 2014). The estimation of the Young's modulus in-field by the direct use of a device has not been

found but methods to evaluate the elastic modulus based on the outputs of certain devices like the Clegg impact hammer are possible.

$$E = 6.0457 e^{0.011\rho} \quad \text{for } 250 \frac{\text{kg}}{\text{m}^3} \leq \rho \leq 450 \frac{\text{kg}}{\text{m}^3} \quad (1)$$

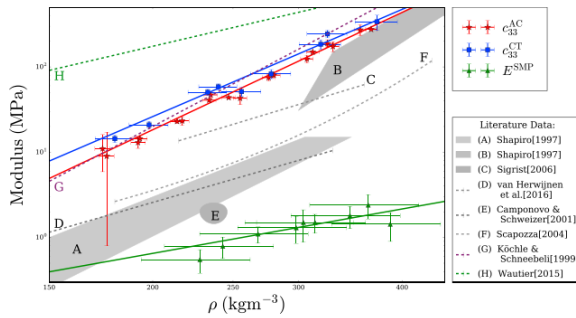

Figure 1: Variation in Young's modulus and performance of acoustic pulse, SMP, and μ CT process for evaluation. Reprinted from (Gerling et al., 2017) with permission of John Wiley and Sons.

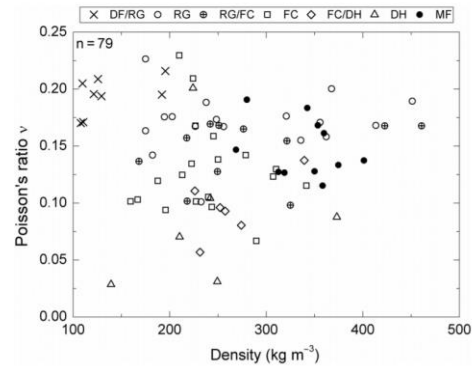

Figure 2: Poisson's ratio variation with variation in density and grain type. Reprinted from (Köhle and Schneebeli, 2014) under Open Access

2.3 Other mechanical properties

Some other important properties of snow like the compression and shear strength and their respective deformation characteristics have been researched over the years (Muro and O'Brien, 2004). The evaluation of the Poisson's ratio is essential as coupled with the Young's modulus, the pair of properties enable us to compute shear and bulk modulus of snow if the snow is assumed to be a linear elastic material. However, on assuming a viscoelastic or elastoviscoplastic nature of snow, the values found in literature tend to be the complex Poisson's ratio, instead. The complex Poisson's ratio is also dependent on density (Smith, 1969) but the quantification of this relation is not found by the authors in the literature reviewed. The values reported in the literature are as low as 0.025 (Köhle and Schneebeli, 2014), but for the range of compacted snow densities, the value of Poisson's ratio (complex) is found to vary between 0.1 and 0.4 (Mellor, 1975). This could be attributed to the variation in the microstructure of the snow (Köhle and Schneebeli, 2014), depicted in Figure 2.

Another property of snow worthy of engineering interest is the compressive strength of snow. The uniaxial tensile and compressive strength of snow at low densities is nearly equal but with an increase in density, the compressive strength

increases reaching nearly 5 times the tensile strength by the time ice density is achieved (Mellor, 1975) (Figure 3). Further, the relation between the unconfined compressive strength (σ_c) is found to be dependent on the temperature (T) (Ramseier, 1961) according to eqn. (2).

$$\log\left(\frac{\sigma_{c2}}{\sigma_{c1}}\right) = 0.16 \log\left(\frac{T_2}{T_1}\right) \quad (2)$$

The shear strength of compacted snow is an important parameter in the case of trafficability studies as it affects the tire performance. The measurement of snow shear strength in-field can be performed in several ways detailed in section 3.2. On careful examination of pre-collected data (Mellor, 1975), it was found that for moderately dense snow (360-590 kg/m³), the cohesion parameter is nearly zero at the initiation of the sintering (Fierz et al., 2009) process, thus implying that the shear strength is completely dependent on the normal stress and friction angle (according to Mohr-Coulomb). After a long period of sintering, the shear strength increased by more than an order of magnitude with a rise in the normal pressure. In general, the trend in density and shear strength is nearly linear (semi-log plot) till a change in slope occurs as the density nears 500 kg/m³, as shown in Figure 4.

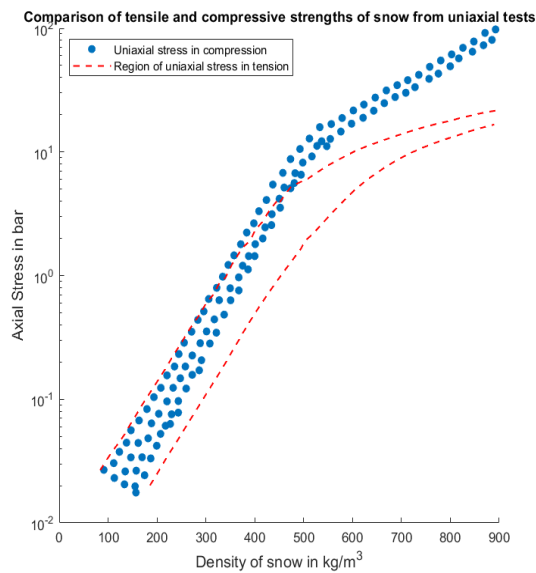

Figure 3: Variation in tensile and compressive strengths from uniaxial tests with change in density. Redrawn in agreement to the plot in (Mellor, 1975)

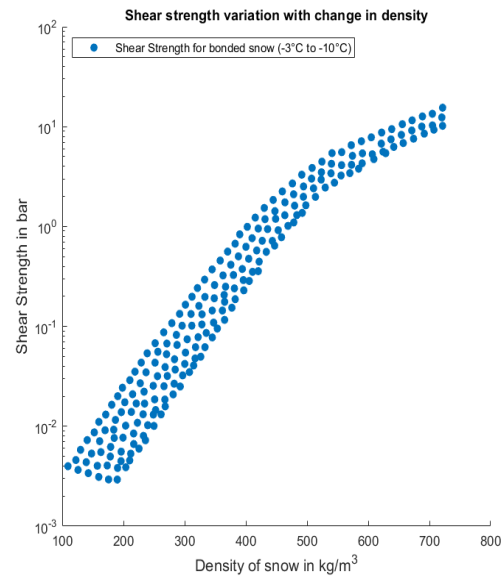

Figure 4: Variation in shear strength with change in density. Redrawn in agreement to the plot in (Mellor, 1975)

3. Testing Methodologies

Snow is characterized by high compressibility and temperature-dependent non-linear viscoelasticity which pose roadblocks to the mathematical modeling of its complex mechanical behavior (Mellor, 1975). The historical approach and evolution of the field of snow mechanics along with the various material types (viscoelastic, elastic, viscoplastic, etc.) used for the modeling of snow were studied (Shapiro et al., 1997). The tire-snow interaction involves snow deformation when the tire moves over it and a shear effect due to transmittable force in the tire-snow contact region. Therefore, knowing the compressive and shear properties of compacted snow are critical in the prediction of snow traction, an important performance parameter for tires used in regions where snow is present for a long time on the ground. For evaluation of the several material properties like density, moisture, etc. various commercially available devices could be used. But from the mobility evaluation aspect, two types of tests are commonly conducted on compacted snow: penetration tests and shear tests.

3.1 Indentation and Penetration Tests

These tests consist of the vertical penetration or indentation of the snow surface using a cone or a plate apparatus, but the standards for the testing devices are framed in the context of soil testing. They could be categorized into laboratory and in-field tests. A major drawback of the laboratory tests is the logistics pertaining to the sampling and storage of snow, so in-field tests are preferred. In these tests, the applied load is recorded and the pressure (p) is calculated based on the device dimensions. The well-known Bekker's formulation (Bekker, 1969) connects the pressure (p) with the sinkage (z) as in eqn. (3)

$$p = \left(\frac{k_c}{b} + k_\phi \right) z^n \quad (3)$$

where the smaller dimension of the contact patch is b , and the pressure-sinkage parameters are n , k_c , and k_ϕ .

Apart from this, Wong's approach (Wong, 2008), was specifically based on pressure-sinkage data from testing on snow covers. The empirical relation derived from this is as shown in eqn. (4), and incorporates the effect of the failure of an intermediate ice layer. In eqn. (4), ' z_w ' denotes the asymptotic value of the pressure-sinkage curve which can be approximated to be the depth of the frozen ground and ' p_w ' is a third of the contact pressure when the sinkage is 95% of the asymptotic value. Improving on Bekker's approach with the introduction of dimensionless constants, Reece (Reece, 1965) proposed eqn. (5).

$$z = z_w \left(1 - e^{-\frac{p}{pw}} \right) \quad (4)$$

$$p = (ck'_c + \gamma_s bk'_\phi) \left(\frac{z}{b} \right)^n \quad (5)$$

According to Wong (Wong, 2008), Bekker and Reece's approach is more applicable to homogenous terrains and some studies have quoted consideration of compacted snow as homogenous, however, according to Wong (Wong, 2010), the application of eqn. (4) for characterizing the pressure-sinkage response of snow is more appropriate. The various commonly used devices used for snow testing are described in this section.

3.1.1 *Rammsonde penetrometer*

The Rammsonde penetrometer is based on the cone penetrometer technique and is vertically inserted into the terrain before dropping a hammer (weight) from a certain height as an impulse. The application of a Rammsonde was envisaged to be on snowy terrain and hence the cone is modified to 60° with a base diameter of 40 mm and height of 35 mm (He et al., 2020) (Figure 5). The cone is attached to a hollow shaft connected to a guide rod (Ueda et al., 1975) on which the hammer can slide freely and apply a force (He et al., 2020). The calculation of penetration resistance is performed using eqn. (6) but its drawback is the assumption of no energy loss on impact.

$$R = \frac{nhW}{S_n} + W + Q \quad (6)$$

where R is the penetration resistance faced by the ram, n is the number of blows, W is the weight of the hammer/ram, Q is the weight of the assembly, h is the height of hammer drop, S_n is the sinkage after 'n' blows/drops.

A realistic estimation of the hardness value by the Rammsonde could be performed with a modified version of eqn. (6), as shown in eqns. (7) and (8), which incorporate the effect of energy losses, and better reflect the results of hardness estimation (Waterhouse, 1966). As shown in Figure 6, the variation in the material affects the evaluated value of hardness, thus the energy losses effect needs to be incorporated.

$$\bar{R} = \frac{W_h H}{S} * \left[\frac{W_h + e^2 W_t}{W_h + W_t} \right] \quad (7)$$

$$\bar{R} = \frac{W_h H}{S} * \left[\frac{W_h + e^2 W_p}{W_h + W_p} \right] \quad (8)$$

where W_h is the weight of the hammer, W_p is the weight of the probe and the shaft, and 'e' is the coefficient of restitution.

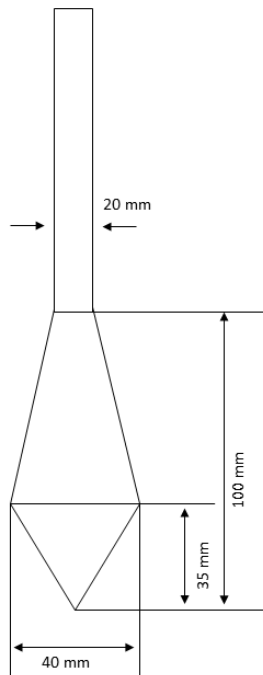

Figure 5: Construction of Rammsonde penetrometer. Redrawn in agreement to the schematic in (Abele, 1963)

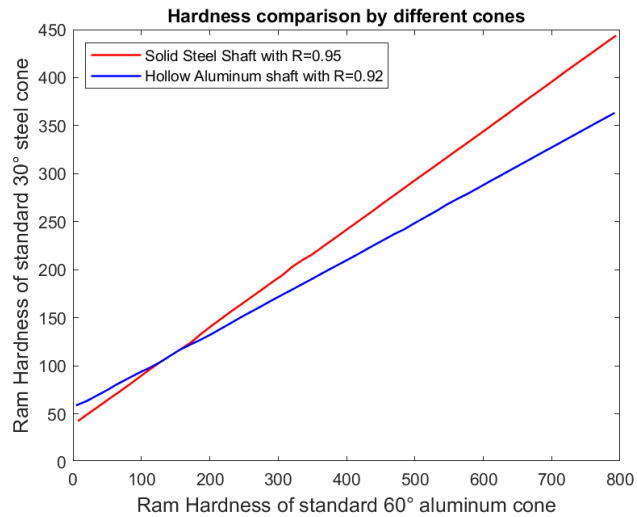

Figure 6: Comparison of hardness measured by different cones in age-hardened snow. Redrawn in agreement to plot in (Niedringhaus, 1965)

The penetration resistance measured by Rammsonde has been found to have a correlation with the unconfined compressive strength of snow (Abele, 1963). However, some drawbacks were reported for the standard Rammsonde in hard compressed snow ((Niedringhaus, 1965; Shoop et al., 2019)). Therefore, an improvised version with the cone angle reduced to 30° was found to be suitable in compressed snow. This variant with the reduction of the base diameter to 11.5 mm and hammer weight of 1.75 kg is also known as the ‘Russian Snow Penetrometer’ (RSP) (Shoop et al., 2019).

The drawbacks of the Rammsonde penetrometer include the possible inconsistency of multiple readings. For example, the time between successive drops was mentioned to be a factor leading to variation in measured hardness, attributed to the settling of snow (Niedringhaus, 1965). A change in the height of hammer drop could affect the hardness values, due to the change in the impact force, unless the rate of penetration was within reasonable limits (Niedringhaus, 1965). Errors could also stem from factors in operator variability like the device not being exactly vertical (introducing friction), or temporal factors like wearing of cone due to continuous use in hard surfaces, or bending of the guide-rod assembly over time, etc. (Abele, 1963). These reasons support the cause of careful measurements by the same operator or with a similar skilled operator, as tracing and rectification of the roots of the variation in measurement due to the human factor would be difficult. Another drawback involves the failure of the Rammsonde device to account for the variations

in the few initial readings at a test location. The readings in the initial 10 cm of the surface were found to be considerably lower (Abele, 1963), which was attributed to the free surface around the cone but could also stem from the effect of ambient temperature on the properties of the snow in the initial 5 cm from the surface. This relation was found to be a logarithmic direct proportional of temperature and surface strength (Abele, 1963), which may also lead to variation in the correction factor required. Another drawback of the Rammsonde involves a reduced accuracy at depths. The former drawback is probably due to the commonly used method of measuring the number of blows required for a specific penetration and calculating the hardness of the snow thereafter. The latter may be due to the reduced performance of the Rammsonde in compressed snows. In conclusion, the Rammsonde results, presented usually as a histogram, could be useful in characterizing compressed snow, but multiple drawbacks discussed above were reported for the standard device.

3.1.2 *Resistograph*

The resistograph was conceptualized (Bradley, 1968) based on the assumption that the resistance of snow during top-down and bottom-up penetration will be the same. This device involves vertical penetration till the base and measurement of resistance during the upward removal. The snow hardness is presented as a continuous function of depth (Lawrence and Bradley, 1973), leading to comparatively better identification of the weaker layers of snow (Figure 7). The major drawback lies in the assumption, specified earlier. Further, the working methodology includes rotation of the device for 90° when it reaches the base reducing the reliability of the measurements in such cases due to loosening of snowpack, and reducing applicability in shallow snow covers. Another drawback is the variation in the magnitude of hardness value measured, when compared to the measurements of a Rammsonde, although a correlation between both exists (Lawrence and Bradley, 1973).

3.1.3 *Snow Micropenetrator (SMP)*

The SMP was devised (Schneebeli and Johnson, 1998) with the idea that a constant rate of penetration and higher sampling frequency could yield a better understanding of the micromechanical effects of snow. The former was achieved by the use of a stepper motor while the latter consisted of the force sensor (mostly piezoelectric) recording values at about every 1/3rd of a millimeter, leading to a variable sampling frequency dependent on the rate of penetration provided by the motor (Figure 8). Some advantages of the SMP include the possibility of measuring the textural index, a ratio of the mean grain size to the snow density (Schneebeli et al., 1999). The SMP was found to better reflect snow properties at higher depths (Hagenmuller et al., 2016), in comparison to Rammsonde and Avatech SP2. The Avatech SP2 is a manually

controlled digital cone penetrometer that measures depth and hardness by a combination of infrared and force sensors per millimeter of depth (Hagenmuller et al., 2018). The geometry of the cone was found to affect the measured hardness (Lee and Huang, 2015), with the larger base of the cone yielding a higher value of force, if the half-angle was constant. On the downside, the SMP is prone to linear drift errors while testing in wet conditions (Meehan et al., 2019). The standard SMP comes with a force sensor of range 0 N to 42 N (Shoop et al., 2019). Even the replacement of this force sensor with a larger one enabling the upper limit to be 250 N (at the cost of resolution), was found to be unsuitable with the hard groomed/compressed snow (Shoop et al., 2019). Thus, the introduction of drift error needs mitigation, and force sensors of better range and resolution are needed for compressed snow testing conditions. The output of the SMP consists of the snow stratigraphy and a plot of the penetration resistance force faced by the sensor with progression in depth. This output would be useful in determining the pressure-sinkage relationship of the snow as well as the compressive strength. In addition, the outputs of the SMP are also useful in the evaluation of density (Kaur and Satyawali, 2017) and Young's modulus (Gerling et al., 2017).

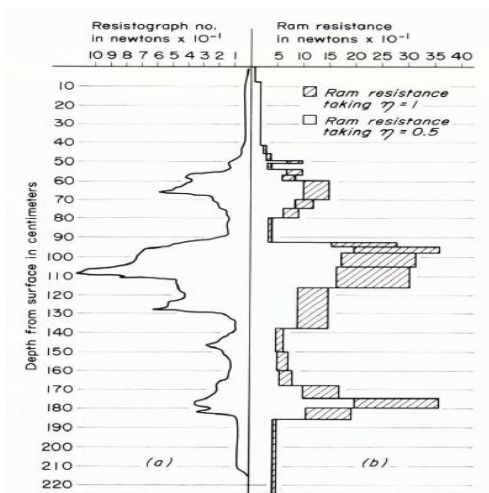

Figure 7: Comparative results of a resistograph to the hardness values measured by the Rammsonde. Reprinted from (Lawrence and Bradley, 1973) under Open Access

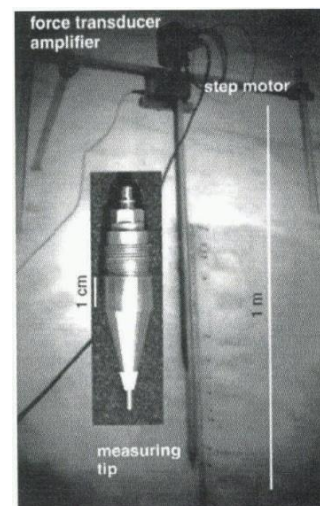

Figure 8: Prototype of snow micropenetrometer. Reprinted from (Schneebeli and Johnson, 1998) with permission from Cambridge University Press

3.1.4 Clegg Impact Tester

This device was developed by B. Clegg (ASTM, 2016) to measure the compaction of the soil as an impact value. It involves dropping a hammer, of a certain size, through a tubular structure from a fixed height (Figure 9) while measuring the hammer deceleration (by employing an accelerometer) which is correlated to the terrain penetration resistance. The

hammer size varies between 0.5 kg up to 20 kg with the standard size being a hammer of 4.5 kg mass. The procedure involves consecutive measurements of deceleration of the hammer with the highest value amongst the first four blows being termed as the impact value. The Clegg hammer can be used to estimate the penetration into the surface based on the double integration of the time-deceleration curve, as shown in eq. (9) (Shoop et al., 2012). Further equations to visualize the value of Clegg Hammer Modulus (comparable to elastic modulus) based on the impact value measured in Clegg units have been devised (Shoop et al., 2012). One such equation for determining Young's modulus of snow by using a 4.5 kg hammer (Shoop et al., 2010) is shown in eqn. (10).

$$z = \frac{h}{10 * C_{max}} \quad (9)$$

$$E = 0.088 * C_{max}^2 \quad (10)$$

where 'z' is the penetration/sinkage in mm, 'h' is the drop height in mm, 'C_{max}' is the maximum value of deceleration in Clegg units (ten times the value in g's), and 'E' is Young's modulus in MPa.

The application of the Clegg tester to evaluate snow properties was first attempted (to the best knowledge of the authors) (Shoop et al., 2010) at the McMurdo station. The findings pointed that the variability in the measured data was high, although this could be attributed to the usage of the standard 4.5 kg hammer, which was found to be heavy enough to plow down into the snow even after 5 drops (Shoop et al., 2012). The lower-sized hammers used for testing (Shoop et al., 2012) led to the conclusion that the medium-sized hammer (2.25 kg) is ideal for testing compacted snow properties.

The advantages of the Clegg impact tester are convertibility to the California Bearing Ratio (Shoop et al., 2019), ease to set up the test, while operator variability effects are reduced unless the drop height is erred. A drawback involves the build-up of snow in the guide tube over repeated testing which could introduce errors in the measured deceleration. In addition, the operating temperature of the electronic components needs to be considered. Resolving these two disadvantages of the Clegg impact tester could make it one of the most appropriate devices for studying compacted snow behavior in compression.

3.1.5 CTI snow compaction gauge

The 'CTI compaction gauge', developed by CTI/Smithers is a device (ASTM, 2020) used to evaluate the snow properties while testing a single wheel on snowy surfaces. It consists of a tip cone but with a rounded vertex of 1.6 mm radius, with the weight being 220±1 g, and the drop height being about 218.9 mm (Shoop et al., 2019). In working, the

cone-rod assembly is dropped from the fixed height and the kinetic energy of the assembly is spent in penetrating the snow vertically and compressing it in the lateral direction. This device combines the action of horizontal (shear) and vertical (compression) forces, to provide the compaction number, an index value between 50 and 100 denoting least and maximum compaction respectively (ASTM, 2020) (Figure 10). By considering the dimensions and properties of the device, it could be possible to evaluate the pressure applied and simultaneously measure the corresponding sinkage at the test location, but the device does not directly output this information.

While this device provides a level of snow compactness (Shoop et al., 2019), its output cannot be directly correlated to the properties of snow, such as the penetration resistance, unless simultaneous measurements with a suitable device are performed. Further, another drawback is the inability to measure snow properties at different depths. However, a positive trend between the results of the light-hammered Clegg impact tester and the measurements of the CTI gauge was reported (Shoop et al., 2019). Though the device has good applicability in compacted snow (Shoop et al., 2019), its applicability for measurements at higher depths is limited. Overall, the ability of this device to characterize/evaluate the snow properties is limited though its outputs can be correlated with the traction performance of SRTT as prescribed in the ASTM standard (ASTM, 2020).

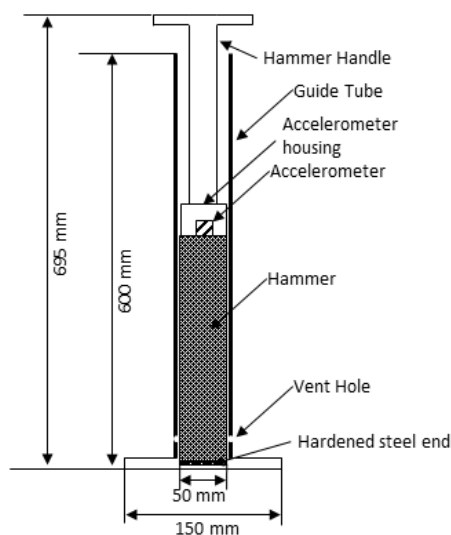

Figure 9: Construction of an impact hammer device used for measuring penetration resistance. Redrawn in agreement to the schematic in (ASTM, 2016)

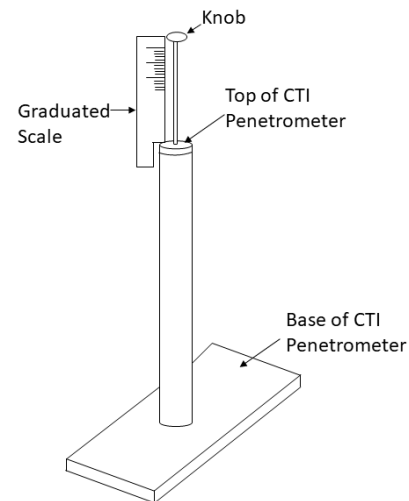

Figure 10: CTI Penetrometer. Redrawn in agreement to the schematic in (ASTM, 2020)

3.1.6 *Plate-sinkage testing methodology*

The plate-sinkage tests apply a normal load to a plate to penetrate the terrain at a constant rate while simultaneously measuring the depth to define the pressure-sinkage relation. One of the accepted practices is to have a plate of such a size that the larger dimension of the contact area is equivalent to the length of the contact patch in the case of tire-terrain contact (He et al., 2020). Very few studies have employed the use of plates for characterizing the pressure-sinkage relation for snow ((Hegedus, 1965; Wong and Preston-Thomas, 1983)), however, the size of the plate did not seem to affect the measured value of the bearing strength of snow (Abele, 1970). Modifications may be required to the plates or the entire methodology to account for variation in snow conditions (Shoop et al., 2019). The bevameter has a module for a plate-sinkage test which consists of a circular plate of diameter 203 mm (Alger, 1988). The module is mounted along the sides of the vehicle which leads to 5 test locations while the vehicle is stationary reducing the manual intervention and operator errors. The major drawback of the bevameter, however, is the bulky apparatus which may add to the overall time to carry out the measurements.

3.1.7 *Other penetration devices*

The drop-cone test apparatus involves dropping an aluminum cone of about 1 kg weight from a height of 10 inches (Shoop et al., 2019) under the forces of gravity. This results in the penetration of the snow by the cone, wherein the penetration depth at the tip is measured in order to define the sinkage. This advantage of a quick test, however, comes at a trade-off as although the applicability of this test is found to be excellent in fresh snow, its reliability reduces in compacted snow which can be attributed to the force not being high enough in order to penetrate the compacted snow. Also, it would be difficult to have multiple readings at the same test location as ensuring the cone follows the exact vertical trajectory, of the previous attempt, would be needed.

The lightweight deflectometer (LWD) is another test allowing a weight to fall freely from a specific height before recording the highest deflection and load (ASTM, 2015). Its applicability in snow property measurement was found to be erroneous (Wieder et al., 2019) as the allowable coefficient of variation for snow isn't available in the standards document (ASTM, 2015). The coefficient of variation is a measure of the deviation from the mean value of the individual data points. Further, the results were found to be affected by the kind of plate that was used, the existence of small deflection value (zero-error), error in the back-calculation of stiffness modulus due to the variation in the measured property values, etc. Also, the assumption of a stiffer surface layer than the subsurface layer (Wieder et al., 2019) in the LWDMod software

may not be accurate while considering snowy terrain. Further in a study by CRREL (Menke et al., 2020), it was found that the lower temperatures of testing were found to affect the accuracy of the device itself, primarily by affecting the properties of the rubber load buffers, hence introducing more factors to which the variation can be attributed. All these drawbacks pose questions to applying LWD for measuring properties of compacted snow.

3.1.8 Summary of penetration tests

This section summarized the various devices employed for the testing of the compressive behavior of snow and the empirical relations commonly used for describing the same. The various advantages/disadvantages of the devices have been highlighted which will make it easier to employ the specific device dependent on the conditions in which snow has to be tested. Based on the literature reviewed, in the case of compacted snow, the authors find the improvised Rammsonde, Clegg impact tester, and CTI gauge to be preferred candidates for measurement of snow properties. Extensive testing undertaken at the South Pole (Shoop et al., 2019) yielded a comparative evaluation of the devices based on the type of snow tested as shown in Table 2, where ‘1’ indicates excellent applicability and ‘5’ indicates bad applicability.

Table 2
Comparison of the effectiveness of various devices in different types of snow (Adapted from (Shoop et al., 2019))

Name of Device	Condition of snow surface tested				
	Hard groomed snow	Medium groomed snow	Fresh snow over groomed snow	Virgin Snow	Ice Layers
Rammsonde	3	2	3 or 4	3 or 4	Not suitable
RSP	1	1	Not used	Not suitable	Not used
SMP	Not suitable	5	1	1	1
Medium Clegg	2	3	5	Not suitable	Not suitable
Light Clegg	2	2	2	1 to 5	Not suitable
CTI	1	1	5	5	Not Used
Drop cone	5	3	2	1	4
LWD	4	4	1	Not suitable	2

3.2 Shear based tests

The shear strength of a material is primarily dependent on the cohesion and the normal stress applied. It has been noted that the shear strength of snow is dependent on the density, strain rate, and overburden weight. The evaluation of the data gathered from snow shear tests is typically interpreted using the Mohr-Coulomb criterion however Wong (Wong, 2008) proposed the shear stress-shear displacement relationship for frozen snow according to eqn. (11).

$$\tau = \tau_{max}K_r \left(1 + \left(\frac{1}{K_r \left(1 - \frac{1}{e} \right)} - 1 \right) e^{1 - \frac{j}{K_\omega}} \right) \left(1 - e^{-\frac{j}{K_\omega}} \right) \quad (11)$$

where ‘j’ is the shear displacement, ‘τ’ is the shear stress, K_ω is the shear displacement when shear stress is maximum, and K_r is the ratio of residual shear stress to the maximum shear stress. Some of the methods used in-field for collecting data on the shear behavior of snow are detailed in this section.

3.2.1 Shear vane apparatus

The shear vane apparatus consists of a cross-shaped blade which is inserted into the snow and rotated using a constant torque before shear failure occurs. The shear strength is approximated using the maximum value of torque applied. The shear vanes have been applied initially in soil testing ((ASTM, 2018a; ASTM, 2018b)) and then in snow testing as well. The various possible geometries are depicted in Figure 11.

In the case of snow, the diameter of the central tube affects the results (Diamond and Hansen, 1956), however, the height of the vane has a negligible effect on the shear measurements in the snow (Evans, 2005). The prior findings using a shear vane in snow have indicated the existence of two peak strengths which is attributed to a failure-plane formation after the first peak strength is achieved (Perla et al., 1982). The drawbacks of this apparatus are that it is dependent on the application of a constant torque which is very difficult if the rotation of the vane is hand-operated. Modifications of the shear vane apparatus to accommodate the variation in snow conditions may be required (Shoop et al., 2019).

3.2.2 Shear frame apparatus

The shear frame apparatus consists of a horizontal box with fins along the cross-section having an area of about 0.025 m² (Perla et al., 1982). The working involves embedding the frame into the snow from the top and pulling it in the horizontal direction (perpendicular to the fins) to find the force required for shear failure (Figure 12). The advantages of an easy-to-adopt and fast test aside, the disadvantage is the susceptibility of the results to the area of the frame as well as

the number of fins (Perla et al., 1982). Most importantly the standard method involves the removal of snow above the testing location, which makes it a time-consuming test. A limitation of this test is the neglect of the normal stress applied by the layers above on shear strength. The shear frame apparatus is a cheap and easy-to-use option for evaluation of the shear strength of snow if this drawback is nullified.

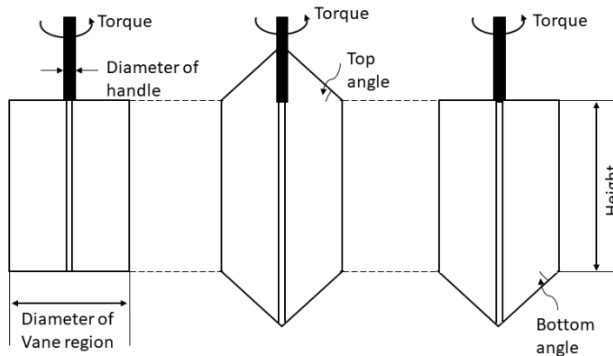

Figure 11: Possible geometries of a shear vane device. Reprinted in agreement to the schematic in (ASTM, 2018a)

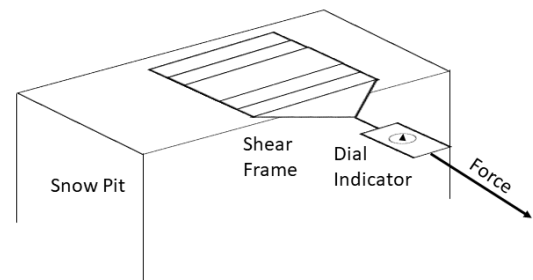

Figure 12: Shear frame device to measure the shear strength of snow. Reprinted in agreement to the experimental image in (Perla et al., 1982)

3.2.3 *Bevometer and in-laboratory testing*

The bevameter module for shear testing consists of an annular ring to which constant rotational velocity is applied by a machine and the shear stress-shear displacement relationship is calculated using the angular displacement of the ring and the amount of torque applied. The Institute for Snow Research's bevameter shear module has a rubber-covered ring (Alger, 1988) with an outer diameter of 92.1 mm. The testing procedure is iterated with 5 levels of applied normal load between 88.96 N and 444.82 N. The plot of the shear stress versus normal stress is used to find the cohesion and shear angle. The major disadvantage of the bevameter is the bulky nature of the equipment.

A method to evaluate the dynamic shear strength of snow, in laboratory conditions, was devised (Nakamura et al., 2010) based on applying vibrations to a block of snow on a plate in which the bottom layers are iced. An embedded accelerometer in the block measures the transverse accelerations before failure occurs. The drawback is the involvement of the sampling and storage of snow which could contaminate the results.

Thus, the shear testing of snow is generally carried out with a focus on the evaluation of properties of cohesion, internal friction angle, shear strength, etc. The rate of applied loading may introduce new factors to be considered and hence they may need to be addressed or kept constant while testing. Overall, it seems that the employment of a shear vane would be

appropriate for characterizing snow shear properties, as the neglect of overburden weight in the shear frame needs to be addressed.

3.3 Snow property characterization using tire traction tests

The idea of the development of a snow mobility model has been in the works for quite a few decades now with a considerable amount of work at the Cold Regions Research & Engineering Laboratory (CRREL). This is due to the possibility of characterizing the snow using the experimentally collected data of tire traction, in what can be considered a ‘reverse methodology’, without the employment of separate devices. In addition to the non-usage of specialized devices, such an approach would also enhance the understanding of as the conditions under which snow characterization would be performed is identical to the broad goal of tire performance on snow.

The earliest model ((Harrison, 1981)) was developed by Harrison from the snow mobility perspective by considering different conditions possible for vehicular movement over snow. A study performed by CRREL (Blaisdell et al., 1990), validated the predictions of the shallow snow mobility model by the usage of a variety of wheeled and tracked vehicles. The majority of the tire testing methodologies tend to report the value of net traction or drawbar pull which is a vector sum of the gross traction available at the contact surface and the resistance forces. The study considers that the resistance force fundamentally comprises of two types of resistances i.e. internal and external and it is the external resistance force (force due to snow deformation) that contributes to the vector summation described earlier. The model works on the assumption that the tire (unless buffed) is capable of engaging the shear strength of the snow and this places a bound on the gross traction available at the tire. The report details procedures to evaluate the internal motion resistance, and total motion resistance resulting in the evaluation of the external motion resistance which is then used to estimate the gross traction in the case of wheeled and tracked vehicles. The approach followed involves multiplication of the Mohr-Coulomb equation by the contact area to have the variables in terms of normal load, inflation pressure, and gross traction (as in eqn. (12)) which is then used to evaluate the cohesion and internal friction angle parameters by having multiple readings of the gross traction at different normal loads and/or inflation pressures. The study highlights the fact that this evaluation by the means of a shear annulus device and based on the tire traction data results in differences especially in the case of the cohesion parameter, as shown in Figure 13. The authors attribute this huge difference to the amount of normal load on the contact surface, variation in the shear rate and the surface in contact with the snow wherein the shear annulus has a smooth rubber surface whereas the tire has its characteristic tread pattern. However, an advantage of the method of

analysis is the evaluation of the cohesion and internal friction parameters as a function of initial snow density, which plays a role in the degree to which the snow is bonded together. The authors have further delved into a regression analysis which led to a conclusion that the wheeled vehicles tend to fit a straight line better on the shear stress versus normal stress plot, as shown in Figure 14, however, the authors have proposed a non-linear relationship with a correlation coefficient of 0.97.

Another validation study focusing on hard-packed snow and snow over ice conditions, performed for the same program (Richmond et al., 1990), led to a finding that most of the time, the tractive effort occurs at compacted snow densities of about 550 kg/m³, irrespective of initial snow density. The snow mobility model proposed proposes theoretical final snow density values based on the contact pressure ranging between 500 kg/m³ and 650 kg/m³ at intervals of 50 kg/m³. By employing a similar process, like the one in (Blaisdell et al., 1990), with an improved mobility model, the authors determined that the gross traction in kPa and the normal stress in kPa in hard-packed snow for wheeled vehicles are related according to eqn. (13). In a study on the Cold Regions Mobility Model (Richmond et al., 1995), the gross traction on processed and packed snow is found to be evaluated using eqn. (12), however, the authors have put forth the notion that in the case of such a snow, very few vehicles with a very high ground pressure could achieve any sinkage, and thus the external motion resistance can be considered zero for all wheeled vehicles. From a traction modeling point of view, this method of evaluating the cohesion and internal friction angle parameters is useful as the validation performed would be related to the end-goal of traction prediction, unlike other cases where the validation needs to be performed by simulating experimental tests conducted with the devices. In the case of compacted/packed snow, where sinkage does not occur unless huge loads are applied, this method would be helpful in the validation of the snow model by simulating the tire-traction test, too.

$$T_g = A * c + W * \tan\phi \quad (12)$$

$$\tau_g = 0.321(\sigma)^{0.97} \quad (13)$$

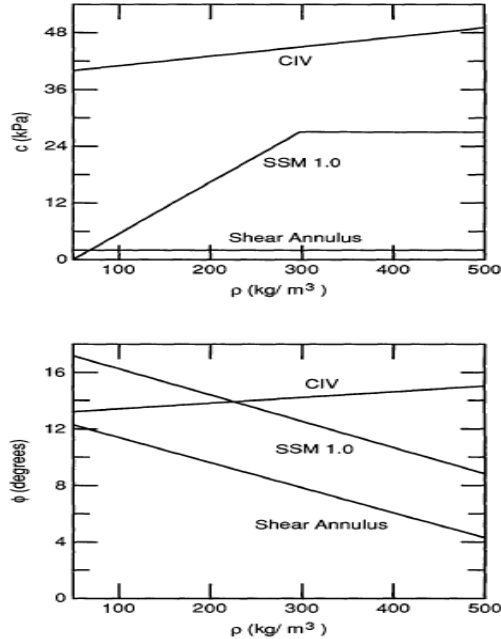

Figure 13: Variation in estimated values of cohesion and internal friction angle using experimental tire traction data and shear annulus method. Reprinted from (Blaisdell et al., 1990) under Freedom of Information Act, USA

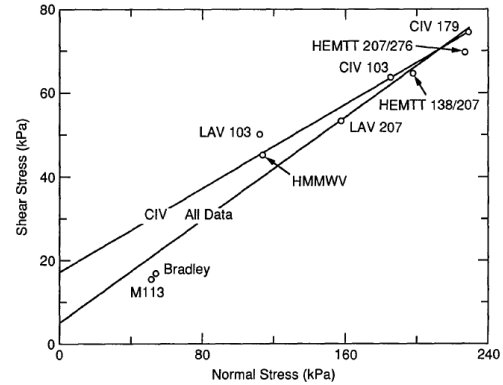

Figure 14: Regression fitting of shear versus normal stress data for different vehicles. Reprinted from (Blaisdell et al., 1990) under Freedom of Information Act, USA.

4. Correlating testing results to the modeling approaches

The goal of computational modeling of compressed snow is to provide an accurate and stable material model to be used in simulating tire-snow interaction. Both classical Finite Element Method (FEM) (Cresseri et al., 2010; Cresseri and Jommi, 2005; Meschke et al., 1996) and eXtended Finite Element Method (XFEM) (Bobillier et al., 2020; El-Sayegh and El-Gindy, 2019; Seta et al., 2003) were applied to simulate the tire-snow interaction. While good results were obtained, especially in the validation of simple compression and shear characterization tests, current state-of-the-art snow material models show poor performance in predicting tire traction (Terziyski, 2010). The inputs required for use in specific modeling technique may vary based on the user application. We attempt to provide a brief description of the correlations that can be directly applicable from testing results from in-field tests to data required for snow modeling and validation in this section.

1. **Rammsonde penetrometer, Russian snow penetrometer and, SMP:** The usage of these devices is primarily for evaluating the hardness/resistance offered by the snow for vertical compression. From the modeling point of view, their result i.e. the hardness profile could be useful to have a snow model that has a variable compressive strength

in response to the external loading, similar to in-field conditions. The SMP has also been found useful to evaluate the density (Kaur and Satyawali, 2017) and Young's modulus (Gerling et al., 2017) which could serve as an input parameter to the model, especially in the finite element method. Further, the textural index of snow evaluated by the SMP could prove to be very useful for defining the size of particles in the XFEM methods. From the validation of the model point of view, the pressure exerted and the corresponding sinkage observed could be a useful output from the tests of these devices however, from the working of the Rammsonde, which measures the average resistance offered by the terrain over a certain depth, this relationship may not be a continuous function of depth.

2. **Clegg impact tester**: The outputs of the Clegg impact tester could be used to evaluate the total penetration into the surface. Although this cannot be a direct input to a specific snow model, it could be used for validation of the developed snow model in a way similar to the pressure-sinkage validation metric. Another output of the Clegg impact tester which is Young's modulus would be useful as an input to the snow model to define the snow properties (Shoop et al., 2012).
3. **CTI snow compaction gauge**: The CTI gauge provides a measure to evaluate the compactness of the snow under consideration however, it does not directly output data that could be used as an input for a snow model. The dimensions of the device (bob) and the fall height, however, could be used to determine the applied pressure on the snow surface. The corresponding penetration distance can be measured using a calibrated scale before conversion to the index values (Shoop et al., 2019).
4. **Plate-sinkage tests**: These tests are comparatively time-consuming and the selection of the plate size needs to be performed carefully. The use of the results of the tests from a modeling point of view is primarily for validation of the model by using the pressure-sinkage relation. The results could also help to evaluate the total bearing strength of snow which may be a definable parameter in the model.
5. **Shear-based tests**: The shear-based tests determine the shear strength of the snow, which would be useful to define the limit of shear possible when an external agent (tire) moves laterally over the snow in a computational model. The output of the shear vanes generally consists of either the torque or the shear strength at failure. The possibility of using a shear vane in tandem with a plate-type of device to apply normal stress could be a useful way to confirm the adherence of in-field snow with one of the failure theories. Besides, by using a shear vane, the shear strength of remolded snow and the sensitivity of the snow could be computed which may provide useful in a snow model for

the multi-pass effect. On the other hand, the output of the shear frame offers a limited possibility for use in a model due to the inherent drawbacks and a single output parameter of shear force at failure.

5. Conclusions

The focus of this work was an extensive review of literature pertaining to compressed snow mechanics which will be useful in the testing of compressed snow.

Accordingly, a thorough review of the various types of devices normally used in the context of snow measurement techniques has been presented while highlighting the working principles, inherent assumptions if any, and advantages/disadvantages of the specific device. It was found that in the context of compressed snow, the commonly used devices like standard Rammsonde or SMP face issues in the measurement while the ASTM standard prescribed device, namely CTI snow compaction gauge, fails to directly measure the properties of the snow providing a compression index value instead. Thus, for compressive testing, the applicability of the Clegg impact tester, and improvised Rammsonde are good candidates for measuring the compressive properties of snow. In shear testing, both the shear frame and shear vane methodologies have their inherent advantages and drawbacks. The shear vane methodology, by mitigating its drawbacks, seems an ideal test, even for a novice operator. The bevameter too is a good candidate for both test types but is bulky and may not be available to all. These factors present an interesting opportunity for a portable device to be developed with a pure focus on the measurement of snow properties in compression and shear. The important properties of snow like density, Young's modulus, compressive strength, and the factors affecting them have been briefly explained.

Acknowledgments

This study has been supported by the Center for Tire Research (CenTiRe), an NSF-I/UCRC (Industry/University Cooperative Research) at Virginia Tech. The authors wish to thank the project mentors and the members of the Industrial Advisory Board of CenTiRe for their support and guidance.

References

- Abele, G. A Correlation of Unconfined Compressive Strength and Ram Hardness of Processed Snow. Series U.S. Army Cold Regions Research and Engineering Laboratory. Hanover, New Hampshire. 1963:1-23.
- Abele, G. Deformation of Snow under Rigid Plates at a Constant Rate of Penetration. Series U.S. Army Cold Regions Research and Engineering Laboratory. Hanover, New Hampshire. 1970.

- Alger, R. G. Shear and Compressive Strength Measurements of Snow Using the Bevameter. First International Conference on Snow Engineering. 1988:89-86.
- ASTM. E2583-15: Standard Test Method for Measuring Deflections with a Light Weight Deflectometer. 2015:1-3.
- ASTM. D5874-16: Standard Test Method for Determination of the Impact Value (I_v) of a Soil. 2016:1-9.
- ASTM. D2573-18: Standard Test Method for Field Vane Shear Test in Saturated Fine-Grained Soils. 2018a.
- ASTM. D8121/D8121m-18: Standard Test Method for Approximating the Shear Strength of Cohesive Soils by the Handheld Vane Shear Device. 2018b:11-11.
- ASTM. F1805-20: Standard Test Method for Single Wheel Driving Traction in a Straight Line on Snow. 2020:1-13.
- Bekker, M. G. Introduction to Terrain-Vehicle Systems. Part I: The Terrain. Part II: The Vehicle. Ann Arbor, Michigan: University of Michigan; 1969.
- Blaisdell, G. L., Richmond, P. W., Shoop, S. A., Green, C. E., Alger, R. G. Wheels and Tracks in Snow: Validation Study of the Crrel Shallow Snow Mobility Model. Series U.S. Army Corps of Engineers, Cold Regions Research & Engineering Laboratory. Hanover, New Hampshire. 1990:1-76.
- Bobillier, G., Bergfeld, B., Capelli, A., Dual, J., Gaume, J., Van Herwijnen, A., et al. Micromechanical Modeling of Snow Failure. *The Cryosphere*. 2020;14:39-49.
- Bradley, C. C. The Resistograph and the Compressive Strength of Snow. *Journal of Glaciology*. 1968;7:499-506.
- Carbone, A., Chiaia, B. M., Frigo, B., Türk, C. Snow Metamorphism: A Fractal Approach. *Physical Review E - Statistical, Nonlinear, and Soft Matter Physics*. 2010;82:1-5.
- Cresseri, S., Genna, F., Jommi, C. Numerical Integration of an Elastic-Viscoplastic Constitutive Model for Dry Metamorphosed Snow. *International Journal for Numerical and Analytical Methods in Geomechanics*. 2010;34:1271-1296.
- Cresseri, S., Jommi, C. Snow as an Elastic Viscoplastic Bonded Continuum: A Modelling Approach. *Italian Geotechnical*. 2005;4:43-58.
- Diamond, M., Hansen, B. L. Use of a Shear Vane in Snow. Series U.S. Army Corps of Engineers, Snow, Ice and Permafrost Research Establishment. Wilmette, Illinois. 1956:1-16.
- Domine, F. Physical Properties of Snow. In: Singh, V. P., Singh, P., Haritashya, U. K., editors. Dordrecht: Springer Netherlands; 2011. p. 859-863.
- El-Sayegh, Z., El-Gindy, M. Modelling and Prediction of Tyre – Snow Interaction Using Finite Element Analysis – Smoothed Particle Hydrodynamics Techniques. *Journal of Automobile Engineering*. 2019;233:1783-1792.
- Evans, E. J. Development of a Rotational Shear Penetrometer for Assessing Snowpack Stability 2005.
- Fierz, C., Armstrong, R. L., Durand, Y., Etchevers, P., Greene, E., McClung, D. M., et al. The International Classification for Seasonal Snow on the Ground. Series IHP, UNESCO Division of Water Sciences. Paris, France. 2009.
- Gergely, M., Schneebeli, M., Roth, K. First Experiments to Determine Snow Density from Diffuse near-Infrared Transmittance. *Cold Regions Science and Technology*. 2010;64:81-86.
- Gerling, B., Löwe, H., van Herwijnen, A. Measuring the Elastic Modulus of Snow. *Geophysical Research Letters*. 2017;44:11,088-011,096.
- Hagenmuller, P., Pilloix, T., Lejeune, Y. Inter-Comparison of Snow Penetrometers (Ramsonde , Avatech Sp2 and Snowmicropen) in the Framework of Avalanche Forecasting. 2016:32-38.
- Hagenmuller, P., van Herwijnen, A., Pielmeier, C., Marshall, H.-P. Evaluation of the Snow Penetrometer Avatech Sp2. *Cold Regions Science and Technology*. 2018;149:83-94.
- Harrison, W. L. Shallow Snow Model for Predicting Vehicle Performance. Series U.S. Army Corps of Engineers, Cold Regions Research & Engineering Laboratory. Hanover, New Hampshire. 1981:1-27.
- He, R., Sandu, C., Mousavi, H., Shenvi, M. N., Braun, K., Kruger, R., et al. Updated Standards of the International Society for Terrain-Vehicle Systems. *Journal of Terramechanics*. 2020;91:185-231.
- Hegedus, E. Plate Sinkage Study by Means of Dimensional Analysis. *Journal of Terramechanics*. 1965;2:25-32.
- Huang, D., Lee, J. H. Mechanical Properties of Snow Using Indentation Tests: Size Effects. *Journal of Glaciology*. 2013;59:35-46.
- Kaur, S., Satyawali, P. K. Estimation of Snow Density from Snowmicropen Measurements. *Cold Regions Science and Technology*. 2017;134:1-10.
- Kirchner, H. O. K., Michot, G., Narita, H., Suzuki, T. Snow as a Foam of Ice: Plasticity, Fracture and the Brittle-to-Ductile Transition. *Philosophical Magazine A*. 2001;81:2161-2181.

- Köhle, B., Schneebeli, M. Three-Dimensional Microstructure and Numerical Calculation of Elastic Properties of Alpine Snow with a Focus on Weak Layers. *Journal of Glaciology*. 2014;60:705-713.
- Lawrence, W. F., St., Lang, T. E. A Constitutive Relation for the Deformation of Snow. *Cold Regions Science and Technology*. 1981;4:3-14.
- Lawrence, W. S., Bradley, C. Comparison of the Snow Resistograph with the Ram Penetrometer. *Journal of Glaciology*. 1973;12:315-321.
- Lee, J. H., Huang, D. Modeling and Testing of Snow Penetration. *Journal of Terramechanics*. 2015;59:35-47.
- Li, L., Sandu, C., Lee, J., Liu, B. Stochastic Modeling of Tire–Snow Interaction Using a Polynomial Chaos Approach. *Journal of Terramechanics*. 2009;46:165-188.
- Meehan, T. G., Marshall, H.-p., Deeb, E. J., Shoop, S. A. Snowmicropenetrometer Applications for Winter Vehicle Mobility. Series U.S. Army Cold Regions Research and Engineering Laboratory.Hanover, New Hampshire.2019.
- Mellor, M. A Review of Basic Snow Mechanics. Series U.S. Army Cold Regions Research and Engineering Laboratory.1975:1-42.
- Menke, A., Wieder, W. L., Shoop, S. A. Using the Light Weight Deflectometer in Winter Climates. Series Hanover, New Hampshire.2020.
- Meschke, G., Liu, C., Mang, H. A. Large Strain Finite-Element Analysis of Snow. *Journal of Engineering Mechanics*. 1996;122:591-602.
- Muro, T., O'Brien, J. *Terramechanics : Land Locomotion Mechanics*. Lisse, the Netherlands ;: A.A. Balkema; 2004.
- Nakamura, T., Abe, O., Hashimoto, R., Ohta, T. A Dynamic Method to Measure the Shear Strength of Snow. *Journal of Glaciology*. 2010;56:333-338.
- Niedringhaus, L. Study of the Rammsonde for Use in Hard Snow. Series U.S. Army Cold Regions Research and Engineering Laboratory.Hanover, New Hampshire.1965:23-23.
- Peinke, I., Hagenmuller, P., Andò, E., Chambon, G., Flin, F., Roulle, J. Experimental Study of Cone Penetration in Snow Using X-Ray Tomography. *Frontiers in Earth Science*. 2020;8:1-17.
- Perla, R., Beck, T. M. H., Cheng, T. T. The Shear Strength Index of Alpine Snow. *Cold Regions Science and Technology*. 1982;6:11-20.
- Petrovic, J. J. Review: Mechanical Properties of Ice and Snow. *Journal of Material Science*. 2003:1-6.
- Proksch, M., Rutter, N., Fierz, C., Schneebeli, M. Intercomparison of Snow Density Measurements: Bias, Precision, and Vertical Resolution. *Cryosphere*. 2016;10:371-384.
- Ramseier, R. O. Some Physical and Mechanical Properties of Polar Snow. 1961;62.
- Reece, A. R. Principles of Soil-Vehicle Mechanics. *Proceedings of the Institution of Mechanical Engineers: Automobile Division*. 1965;180:45-46.
- Richmond, P. W., Blaisdell, G. L., Green, C. E. Wheels and Tracks in Snow: Second Validation Study of the Crrel Shallow Snow Mobility Model. Series U.S. Army Corps of Engineers, Cold Regions Research & Engineering Laboratory.Hanover, New Hampshire.1990:1-43.
- Richmond, P. W., Shoop, S. A., Blaisdell, G. L. Cold Regions Mobility Models. Series U.S. Army Corps of Engineers, Cold Regions Research & Engineering Laboratory.Hanover, New Hampshire.1995:1-78.
- Russell-Head, D. S., Budd, W. F. Compacted-Snow Runways Guidelines for Their Design and Construction in Antarctica. Series U.S. Army Cold Regions Research and Engineering Laboratory.Hanover, New Hampshire.1989.
- Schneebeli, M., Johnson, J. B. A Constant Speed Penetrometer for High Resolution Snow Stratigraphy. *Annals of Glaciology*. 1998;26.
- Schneebeli, M., Pielmeier, C., Johnson, J. B. Measuring Snow Microstructure and Hardness Using a High Resolution Penetrometer. *Cold Regions Science and Technology*. 1999;30:101-114.
- Schweizer, J., Camponovo, C. The Temperature Dependence of the Effective Elastic Shear Modulus of Snow. *Cold Regions Science and Technology*. 2002;35:55-64.
- Seta, E., Kamegawa, T., Nakajima, Y. Prediction of Snow / Tire Interaction Using Explicit Fem and Fvm. *Tire Science and Technology*. 2003;31:173-188.
- Shapiro, L. H., Johnson, J. B., Sturm, M., L., B. G. Snow Mechanics: Review of the State of Knowledge and Applications. Series U.S. Army Corps of Engineers, Cold Regions Research & Engineering Laboratory.Hanover, New Hampshire.1997.
- Shoop, S., Knuth, M., Crandell, J. Using a Clegg Impact Hammer to Measure Snow Strength. *Cold Regions Engineering* 2012: Sustainable Infrastructure Development in a Changing Cold Environment 2012:811-822.

- Shoop, S. A., Phetteplace, G., Wieder, W. L. Snow Roads at Mcurdo Station , Antarctica. Series U.S. Army Cold Regions Research and Engineering Laboratory.Hanover, New Hampshire.2010:1-112.
- Shoop, S. A., Wieder, W. L., Elder, B. C., Beal, S. A., Deeb, E. J. Assessment of Field Methods for Measuring Mechanical Properties of Snow. Series U.S. Army Cold Regions Research and Engineering Laboratory.Hanover, New Hampshire.2019.
- Sigrist, C. Measurement of Fracture Mechanical Properties of Snow and Application to Dry Snow Slab Avalanche Release 2006.
- Smith, N. Determining the Dynamic Properties of Snow and Ice by Forced Vibration. Series U.S. Army Cold Regions Research and Engineering Laboratory.Hanover, New Hampshire.1969;216.
- Terziyski, T. Tire Performance Evaluation for Severe Snow Traction. Simulia Customer Conference. 2010.
- Ueda, H. T., Sellmann, P. V., Abele, G. USA Crrel Snow and Ice Testing Equipment. Series U.S. Army Cold Regions Research and Engineering Laboratory.Hanover, New Hampshire.1975:17-17.
- Wang, X., Baker, I. Observation of the Microstructural Evolution of Snow under Uniaxial Compression Using X-Ray Computed Microtomography. *Journal of Geophysical Research: Atmospheres*. 2013;118:12,312-371,382.
- Waterhouse, R. Reevaluation of the Rammsonde Hardness Equation. Series Hanover, New Hampshire.1966.
- Wieder, W. L., Shoop, S. A., Barna, L. Using the Light Weight Deflectometer to Assess Groomed Snow and Ice Surfaces. Series U.S. Army Cold Regions Research and Engineering Laboratory.Hanover, New Hampshire.2019.
- Wong, J. Y. *Theory of Ground Vehicles*. 4 ed: John Wiley & Sons; 2008.
- Wong, J. Y. *Terramechanics and Off-Road Vehicle Engineering : Terrain Behaviour, Off-Road Vehicle Performance and Design*. Second edition. ed. Oxford: Butterworth-Heinemann; 2010.
- Wong, J. Y., Preston-Thomas, J. On the Characterization of the Pressure-Sinkage Relationship of Snow Covers Containing an Ice Layer. *Journal of Terramechanics*. 1983;20:1-12.