

## CHAPTER 7. SYSTEM DESIGN

### 7.1 Introduction

System design consists of determining system (or subsystems) software and hardware that will work coherently in order to perform altogether as a warning and safety system. As we have described above, the system could be subdivided into 4 subsystems:

- 1-Detection subsystem.
- 2-Control Processor.
- 3-Warning subsystem.
- 4-Communication subsystem.

### 7.2 System Algorithm

The system components are put together and run by the system logic or algorithm depicted below, which consists of a sequence of loops and “if...then” statements.

The system starts with the surveillance mode. Once a vehicle enters the field of vision or the image frame of the video camera, the system will count it, record its attributes (direction, class and speed) while running passing detection (or wrong-way) algorithm. If no violation was detected the system will go back to its initial mode “watching” for another vehicle coming. If not, it will activate the warning system with message 1, and it also activate a license plate image capture camera. The System Algorithm is shown in Figure 7-1.

The system can be developed in a way that if the detection subsystem “sees” that another vehicle is coming in the opposing direction while a violation is in the course, the system could display another warning message to urge the offender to take the appropriate action and resume his path.

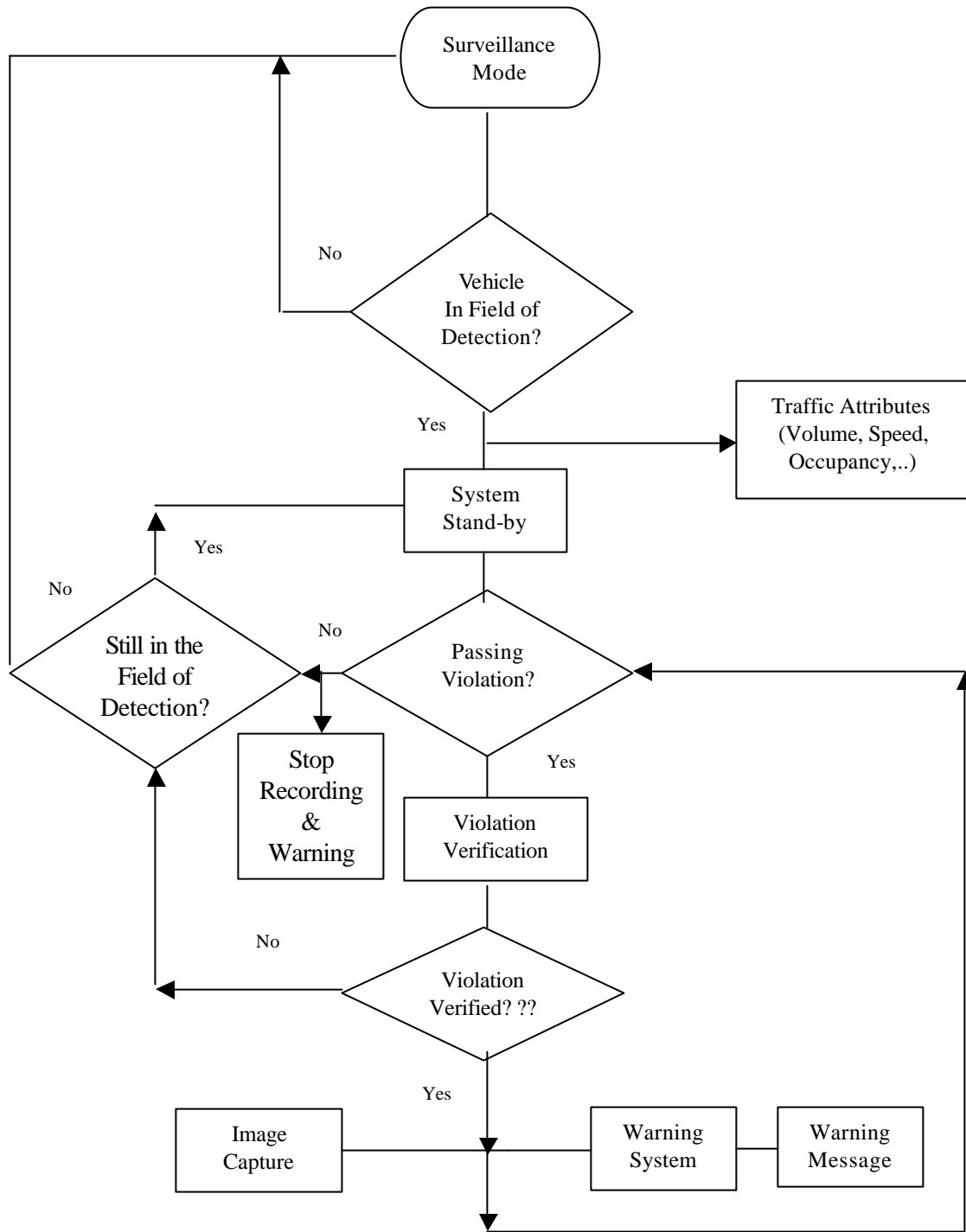

**Figure 7-1. System Algorithm**

### **7.3 Detection System Design: Video Image Processing (VIP)**

Several technologies have been developed to detect vehicles on the road. The loop detectors embedded in the pavement were extensively used in the early development of the technologies. They relied on the magnetic fields and the changes in it to detect the presence of vehicles and then the time difference between the vehicle passage from one to another to give the speed and other traffic flow characteristics. A lot of advancement has occurred from that point on and now more advanced machine vision is being used to capture such kind of data. The video image analysis, a very recent technique, involves studying the traffic the captured image a camera and then conduct analysis by studying this image.

The video analysis essentially involves the transmission of the image from the camera and then processing of it so as to extract the necessary data. Various algorithms and technologies exist in identifying the vehicles from the images captured by the video cameras. One first step toward selecting the most appropriate system for this project was to examine the most predominant video detection technologies: the Tripline and the Tracking technologies, which are discussed further in a bit more detail.

#### **7.3.1 Tripline**

The first non-military Tripline-based video vehicle detection system, Autoscope, was developed at the University of Minnesota starting in 1984. Numerous other Tripline-based video detection systems have entered the traffic marketplace in the nineties such as VANTAGE, TraffCam, and C-CATS.

Tripline-based image processing technology is characterized by digitization of a small row or rows of pixels in the camera's field of view. These digitized pixels are analyzed 30 times per second for changes in the background gray scale, and then compared to a background reference image. Although the operator is able to view the entire camera image, yet the processor does not analyze every pixel in the image (see Figure 7-2). True "wide area detection" would encompass the entire field of view. However, Tripline detection is a lot like

emulating the loop detector, the only difference being an above ground point detection system. The above ground Tripline video detection is far better than the in-ground sensors, as it is not prone to installation and maintenance problems associated with in ground sensors. Also these systems are able to provide more comprehensive and reliable real time traffic data than ground sensors.

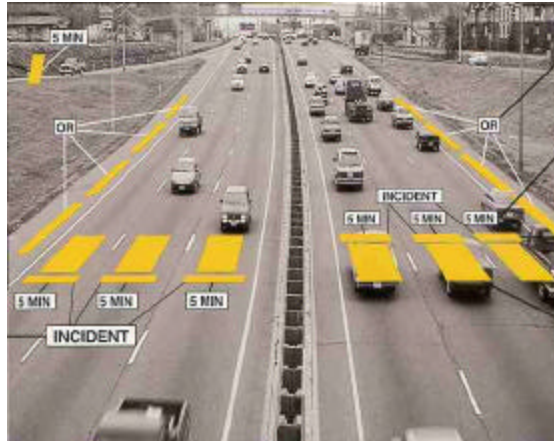

**Figure 7-2: Tripline Type Of Vehicle Video Imaging Detection**

### 7.3.2 Tracking

Early tracking systems, mostly used for military purposes digitized and analyzed every pixel in the camera's field of view 30 times per second. But on the commercial side, this meant more processing time required to analyze every pixel in the camera's field of view. Having the real time capability to generate x-y coordinate for any vehicle or object, which moves into the field of view (see Figure 7-3), and to track that object in any direction or orientation provides far greater information about traffic flow and behavior than Tripline video technology. Tracking-based technology gives relevance to where vehicles are coming from, where they are going (direction), or if they have stopped. Accurate detection is a simple by-product of tracking based algorithms and filters.

Another advancement was the multi-resolution tracking. This multi-resolution 'pyramid' processing technology was based on the principle used by the human eye. The 'Pyramid processing' is used at the core. The human eye sees the details at close range and coarse images at distances simultaneously (Figure 7-4). Pyramid Processing converts the high-

resolution input image to a cascade of lower resolution images in real time via specialized pyramid chip. Analysis is further performed on the image at the lowest possible resolution, thereby reducing the processing time and power. This kind of processing permits every pixel in the camera's field of view to be digitized in real time, as the system performs full flow based tracking and detection of automobiles, trucks, motorcycles, bicycles and pedestrians.

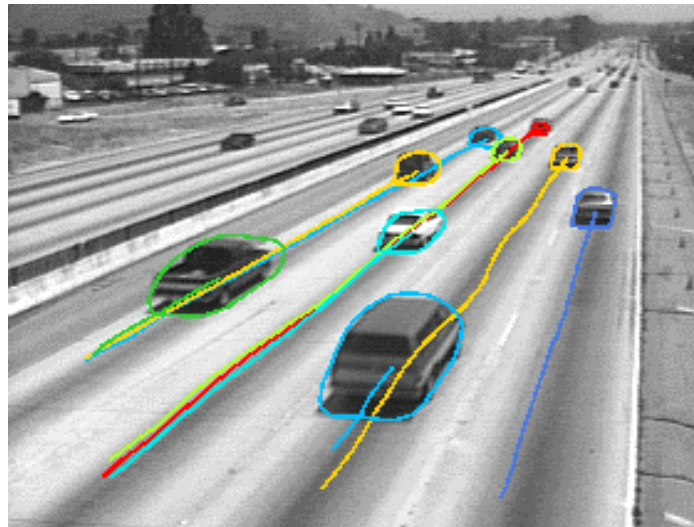

**Figure 7-3: Video Detection Using Tracking Algorithms**

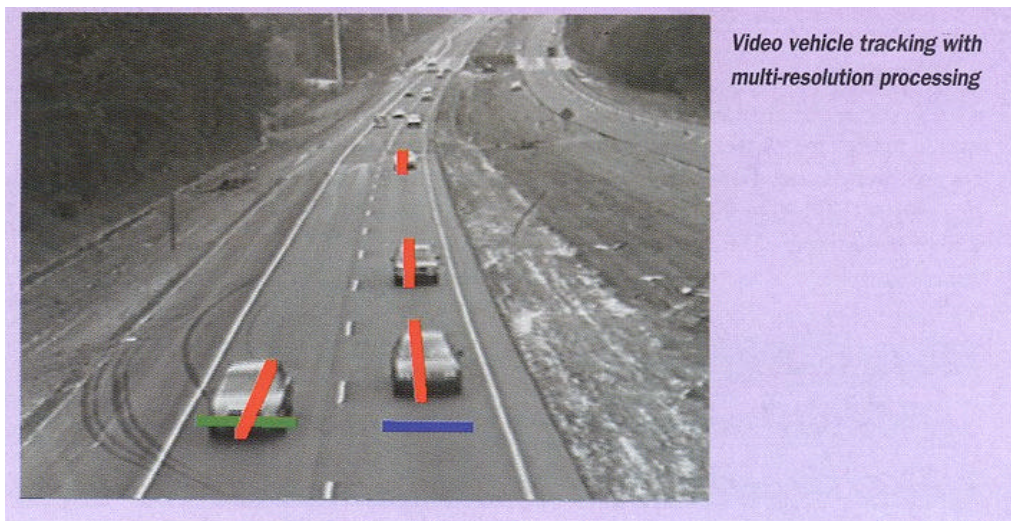

**Figure7-4: Multi-tracking Technology Detection By VideoTrak**

### **7.3.3 System Selection Process**

Typically, the selection of a system is based on many criteria related to the technology used, measures of performance, cost, and technical support.

#### ***7.3.3.1 Technology***

As far as technology is concerned, we have seen that tracking technology is the most appropriate approach for our problem, since it is capable to generate x-y coordinates for any vehicle moving in its field of vision, hence, capable of tracking that vehicle in any direction or orientation. Such capability would provide greater accuracy about traffic flow and behavior than Tripline video technology, especially when dealing with a direction violation issue. This issue is a critical problem that needs real-time information for prompt detection, and countermeasure decision.

#### ***7.3.3.2 Measures of Performance***

There are many metrics, which characterize the performance of Video Image Processing (VIP) detection systems. The detection rate, false alarm rate, and detection time of a VIP system are particularly important:

- 1- False Alarm Rate (FAR): Defined as the fraction of incorrect detections to the total number of detections. The FAR is typically expressed as a percentage, but may also be given as the number of false alarms per time period
- 2- Detection Rate (DR): Defined as the number of detected incidents to the actual number of incidents in the data set, the DR is given as a percentage.
- 3- Time to Detection (TTD): Defined as the average time required to detect an incident. It applies at a given FAR and DR.

The performance of VIP detection may vary with several environmental variables, including:

- Variable lighting conditions, particularly during sunset and sunrise
- Camera angle, height, and position
- Adverse weather conditions (e.g.. rain, fog, and wind)
- The presence of camera vibration

Other performance issues from the perspective of the transportation authority include:

- Measurement accuracy of traffic parameters
- Vehicle classification reliability
- Ease of setup and operation
- System failure rate and ease of recovery
- Compatibility with other TMC elements
- User interface, data storage, and data displays

Actually, among the many technologies reviewed, and taking into consideration the on- the- shelf technologies and products available, two systems have been found to be the most competent in fulfilling the proposed system requirements: Autoscope (2004 or Solo) by Econolite, and VideoTrak910 by Peek Vision systems.

As both were serious candidates to supply the equipments needed, several separate meetings have been held with their technicians and VDOT engineers, in which the various aspects of the project were discussed, visits were made and offline tests were offered by the two competitors. The outcome of those exercises was to evaluate both offers from cost, technical support and after sale service viewpoints. The final decision was to select the Autoscope system.

### **7.3.4 Layout of The Cameras**

Detection area size that could be covered by one camera depend on many factors such as the camera lens, the height of the camera, the lateral distance from the edge of the lane, and the geometry of the road.

A rule of thumb states that the farthest point that a video camera can view is at ten-fold its height measured from the camera pole. So one may expect a camera installed at 40 feet height could detect vehicles 400 feet far from its pole. For better and clearer detection, one could ease this assumption for shorter distance. In fact, for our 2100 feet-long stretch of road to be put under surveillance, and taking into account the geometry of the road, and the overlapping areas between two consecutive cameras, it was found that we need 8 cameras for full coverage.

Figure 7-5 shows a general layout of the video camera locations along the road.

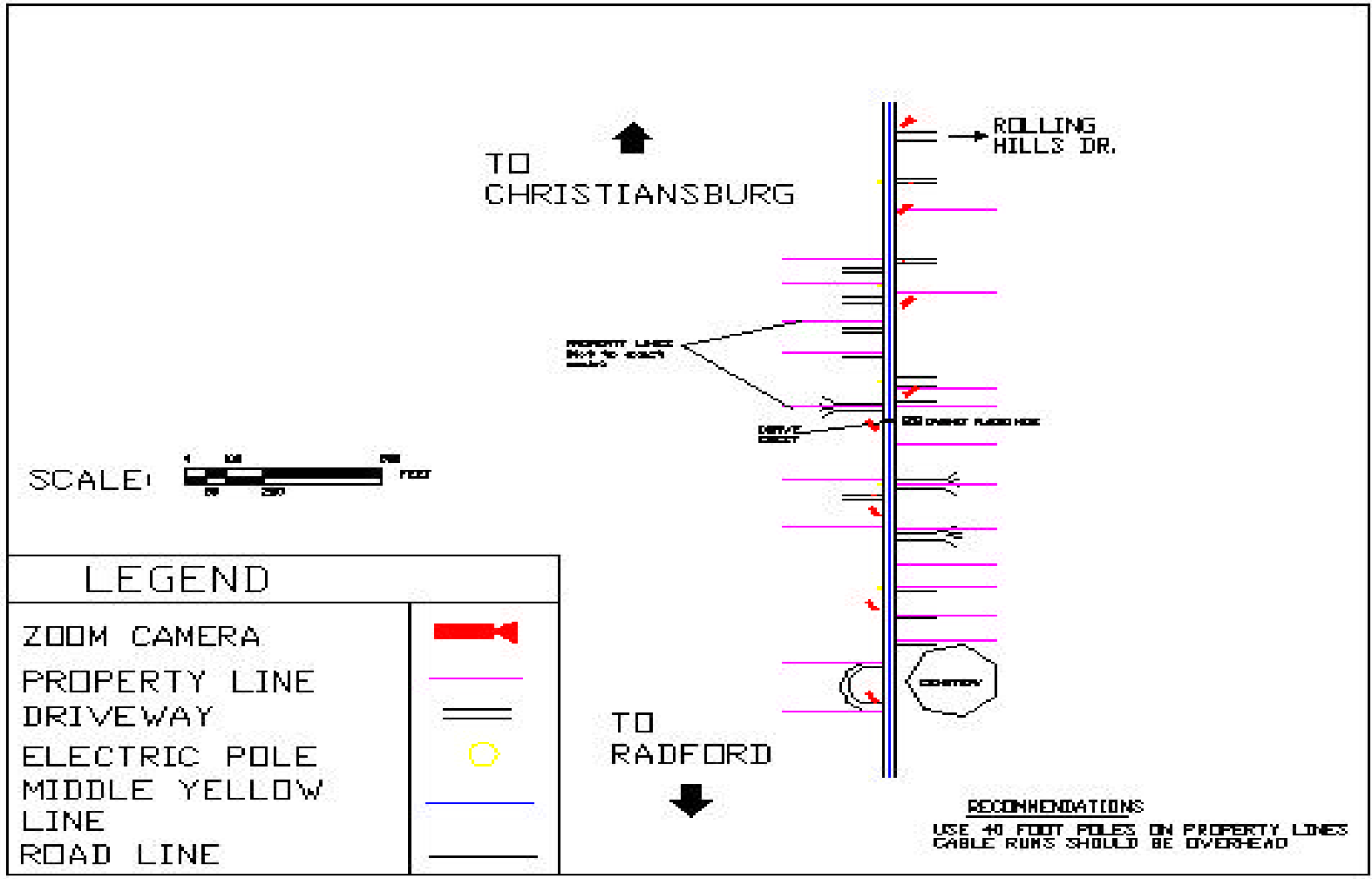
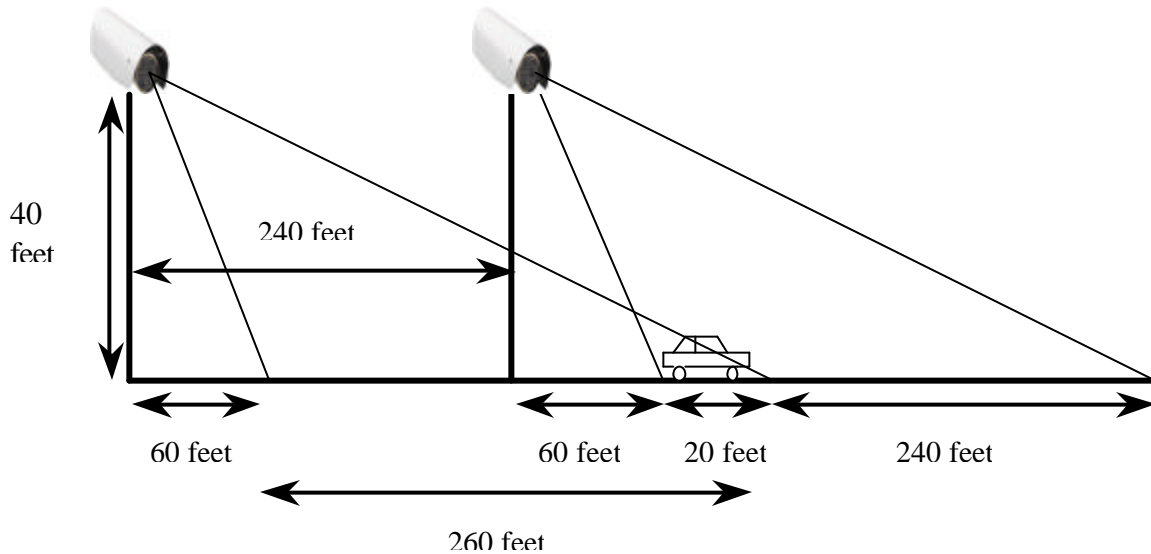

Figure 7-5: Video Cameras Locations Layout



The overlapping portion assures the continuity and harmony of the detection function. In fact, as Figure 7-6 shows, the design considers at least 20 feet at the end of one camera detection area overlapping with the beginning of the area of the camera that follows.

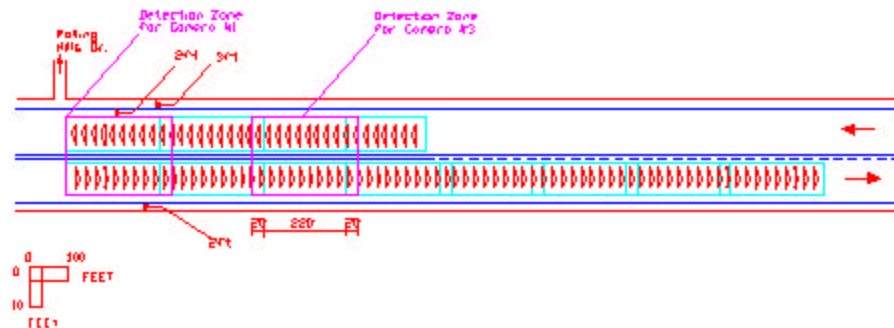

**Figure 7-6: Video Cameras Detection Area**

The figure illustrates that for a 40-foot camera height, the farthest point considered in the detection area by one camera is at 320 feet from the camera pole (around 8 times the height) and the closest is 60 feet. Thus the detection zone length covered by one camera would be 260 feet long with 20 feet overlapped at each extremity.

The overall system detection layout is shown in Figure 7-7. The figure illustrates the detection areas covered by each of the eight cameras, overlapped at both ends (except the first and last cameras). Now the first four cameras starting from Rolling Hills Drive side need to detect violations in both directions, therefore, the detection areas of those cameras are divided into two sub-areas, each covering one lane direction. Consequently, every one of these two sub-areas will receive different programming by the system “Wrong Way” algorithm to detect the violating vehicles of its corresponding direction. For the remaining four cameras, we need to limit detection to the westbound lane for the traffic coming from Radford only, because passing in the other direction is permitted.

The total detection areas covered by the system layout described above would be around 2100 feet long.



**Figure 7-7: Overall system Detection Layout**

#### **7.4 Control Processor System: Autoscope Solo**

Autoscope Solo Machine Vision Processor (MVP), by Econolite, provides a variety of data and applications like:

- Directional Detection
- Stopped Vehicle detection
- Automated incident Detection application
- Support for variable message signs
- Traffic Volume
- Vehicle Classification
- Occupancy
- Custom applications

The system features that stand out are the camera coverage which can be verified on a monitor, the wide coverage, and the compatibility of video signals being able to be sent by coaxial wires or fiber-optic, twisted pairs or wireless. Also, they are proven to be accurate even for varying lighting conditions and weather conditions. Their flexible detector layout is also an added advantage, where the zone is variable from 1.5-30 meters, depending on the height and 256

zones can be distributed across up to 8 cameras (32 per camera). A single camera could also cover a range of up to 6 lanes.

Listed below are the system specifications:

**Dimensions:** 123.9 mm X 127 mm X 432.8 mm (HxWxL)

**Power:** 24~VAC/DC, 30 watts, 50/60 Hz

**Environmental:** -34° to +60 C,

**Humidity:** 0% to 95%, Relative humidity

**Video Input:** NTSC or PAL formats

**Serial Communication:** Two RS-485 ports for serial communications up to 56.8 baud.

Communications protocol shall be UDP/IP

## 7.5 Warning System Design: The Warning Sign

The purpose of the warning system is to provide information for violating motorist to make rapid decisions in response to the capture of his or her illegal maneuver.

The Steps for a warning system design consist of:

- Identify the problem to be solved and role of message sign within the system.
- Identify driver information required for specific objectives of the sign, and design appropriate messages to meet driver's needs.
- Determine placement and any environmental restrictions and assess their impacts on sign functions.
- Balance restriction with needs and design the sign and letter height accordingly.

Sign messages are the warning system interface with the drivers. They should normally be displayed only when some response or decision by motorist is required. In our case, the message is to be displayed only to the motorist who is violating the no-passing zone to alert and warn him or her. Therefore the sign ought not be like the other conventional static signs; rather it should be a dynamic one displaying the proper message (warning) to the proper audience (violator).

**Control Logic:** The control processor will control the message sign. The control logic of the sign is in two parts:

1. Whether a measure is required or not.

2. What message to display.

Control logic for the sign messages should be established to help decide when specific messages should be displayed or changed based on detection outcome. It is activated when a violation is verified and the warning message needs to be displayed. In case the system was developed to detect for coming opposing traffic, the warning system then could have other messages to display (using variable message sign VMS).

**Message design:** Two types of message format have been taken into consideration: abbreviation and wording (no standard icon for passing prohibition exists). Abbreviations are generally used to shorten long words. However, it was found that abbreviations take between 800 to 1000 milliseconds to read by the motorist (Rogers and Moeller, 1984). This is considerably slower than the 250 milliseconds per word rate of average reading. Nevertheless, abbreviations are clearly harder to read than non-abbreviated words of similar length.

Hence, for this case it is best suited not to use abbreviations but full wording. This implies that the message should be as short as possible. It should in the same time be the clearest and the least confusing as well. After thoughtful thinking of what the message could be, we reached to the following conclusion: The simplest warning message would be the standard static “DO NOT PASS” regulatory sign, modified to dynamic (electronic) and equipped with a flashing light.

Message word sequence and format will be:

<b>Audience</b>	<b>Instructions</b>	<b>Message#</b>
Violator	DO NOT PASS	M1

In the case where the system is developed to detect vehicles coming in the other direction, a second message is displayed to warn and order the violator as follows:

<b>Audience</b>	<b>Instructions</b>	<b>Message#</b>
Violator	WARNING // KEEP RIGHT	M2

- All words are in upper case
- Single strike font is used.

### 7.5.1 Sign Design

Four signs could be installed, two on each side of the crest of the road vertical curve. The sign will display messages on one face side of the panel directed towards the coming violator.

Referring to the Manual of Uniform Traffic Control Devices (MUTCD), signage design should follow certain standards in the shape, color, lettering, dimensions, position and erection:

**Shape:** As it falls in the regulatory category, the shape of the sign should be rectangular

**Color:** Usually yellow is used for background of ordinary warning sign. As we are emphasizing the regulatory aspect of our message, the background chosen will be of that category, white.

**Lettering:** The size of letters (height, thickness and spacing) is a function of speed. Therefore, letters of the type included in the “Standard Alphabets for Highway Signs” approved by FHWA will be adopted, and 10" upper-case character height in front display could be used.

**Dimension:** Sign dimensions are a direct function of letter size, number of lines and the number of words per line.

**Illumination:** could be done by several means. The recent and proven as we have seen is the LED. Others could be luminous tubing, or fiber optic shaped to lettering.

**Sign borders:** A dark border will be set in from the edge, while a white border should extend to the edge of the panel. A suitable border for the size of the selected sign could be about 1 inch width and ¾ inch from the edge.

**Placing side:** Because the driver about to pass the vehicle ahead often has only a restricted view to the right, consideration should be given to placing the sign on the left-hand side of the roadway.

**Position:** As a rural road, the sign will be erected so that its closest edge is at least 12 feet away from the left hand side of the pavement edge.

**Height:** Roadside signs in rural areas are usually mounted at a height of at least 5 feet measured from the bottom of the sign to the near edge of the pavement.

Figure 7-8 shows the layout of the warning sign.

### 7.5.2 Infrastructure Components

For this project, and for one sole warning message, we just need a display board with retro-reflective face on which the message is displayed. The selection of appropriate display board

depends on many factors of which are the objective of sign; the messages to be displayed, the legibility distance and location of sign panel for drivers to read and comprehend the messages; the environmental conditions; and the cost of candidate signs.

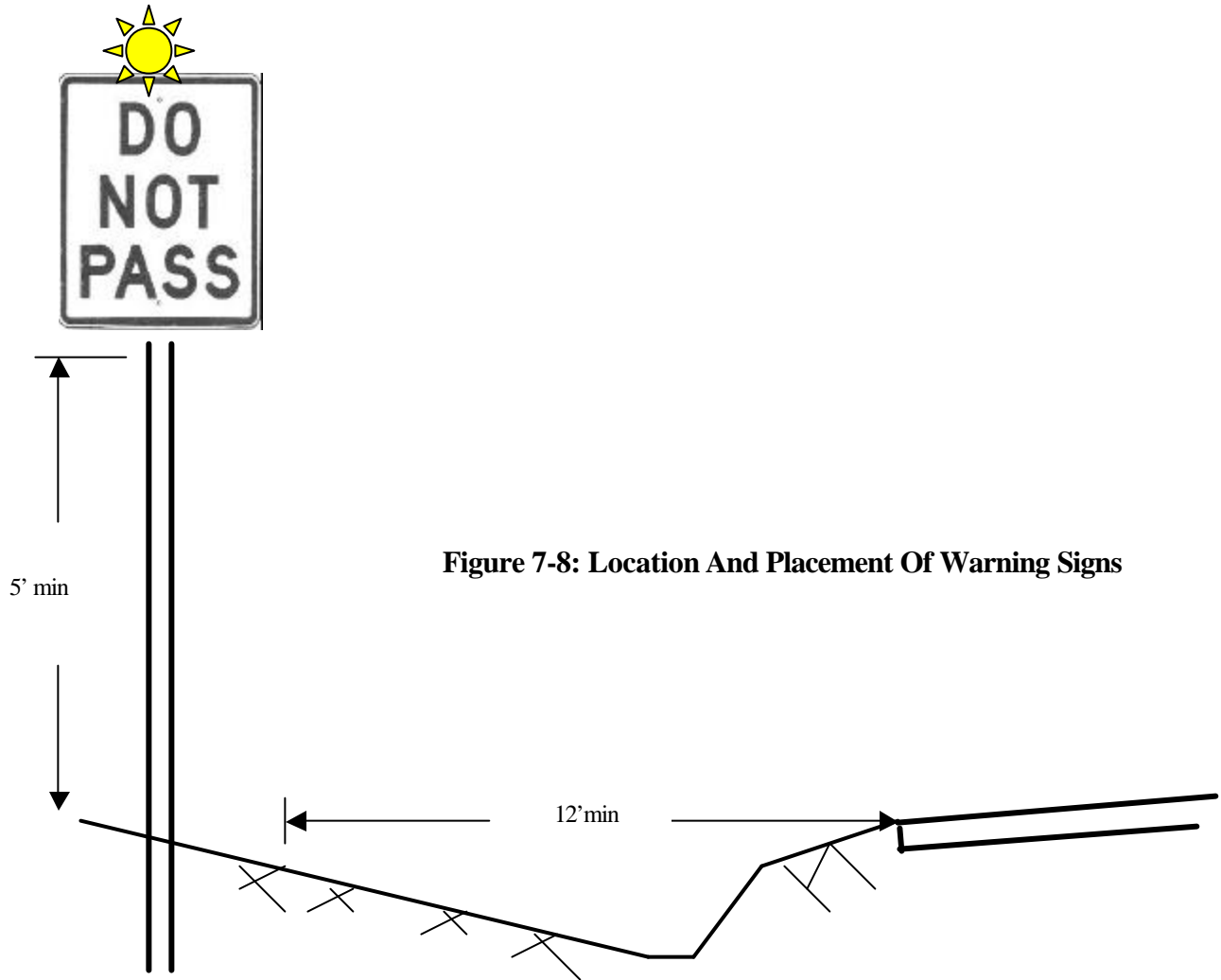

**Figure 7-8: Location And Placement Of Warning Signs**

One of the display technologies that we may select is the Light-Emitting Diodes or LED. The LED have been tested and proven to have good legibility distance for daytime and nighttime lighting conditions. Some positive attributes of the LED sign include good target value, minimum maintenance, long bulb life, legibility, conspicuity, no moving parts, color capabilities, fast updates on messages, back-lit legibility.

The negative points of using this include items such as power consumption is high because fan ventilation is required to dissipate heat produced by LEDs, small cone of legibility (viewing angle) than fiber optic signs, and weight.

## **7.6 Communication System Design**

The camera is connected to the control processor equipment on the roadside from where the message panel is turned on and off directly. Data could be sent to a control center through the telephone network-mode system as shown in Figure 7-9. This will enable the control processor equipment to be connected to a control center computer directly when needed for monitoring or for data transmission via the serial port and using RS-485, protocol.

As a violation is detected and verified, a self-triggering mechanism is used to start the capturing of violator license plate and a warning message will be displayed. This may also trigger a communication to the control center where a check can be done visually to verify the situation and make the appropriate decision.

The control center, from its part, can access and download data that need be transmitted whether images, captured license plates and other by-products like vehicle counts and speed.

### **7.6.1 Choice of Video Transmission Medium Systems**

The Autoscope Machine Vision Processor is a self-contained unit that processes the real-time images from image sensors, sends detector outputs to a controller or remote computer, and activates the warning sign once a violation is detected.

Transmission of video signals can be by coaxial cable, fiber optic cable, twisted-pair wire, wireless RF, or microwave. However, since Autoscope Solo chosen is integrating video camera and machine vision processor into one compact unit, we may use twisted pair wire as transmission channel to an interface card, to which a modem could be connected, whereas telephone lines (twisted pairs or T1 lines) will ensure the connection with the control center. A general layout of the communication system is presented in figure 7-9 with the key specifications being:

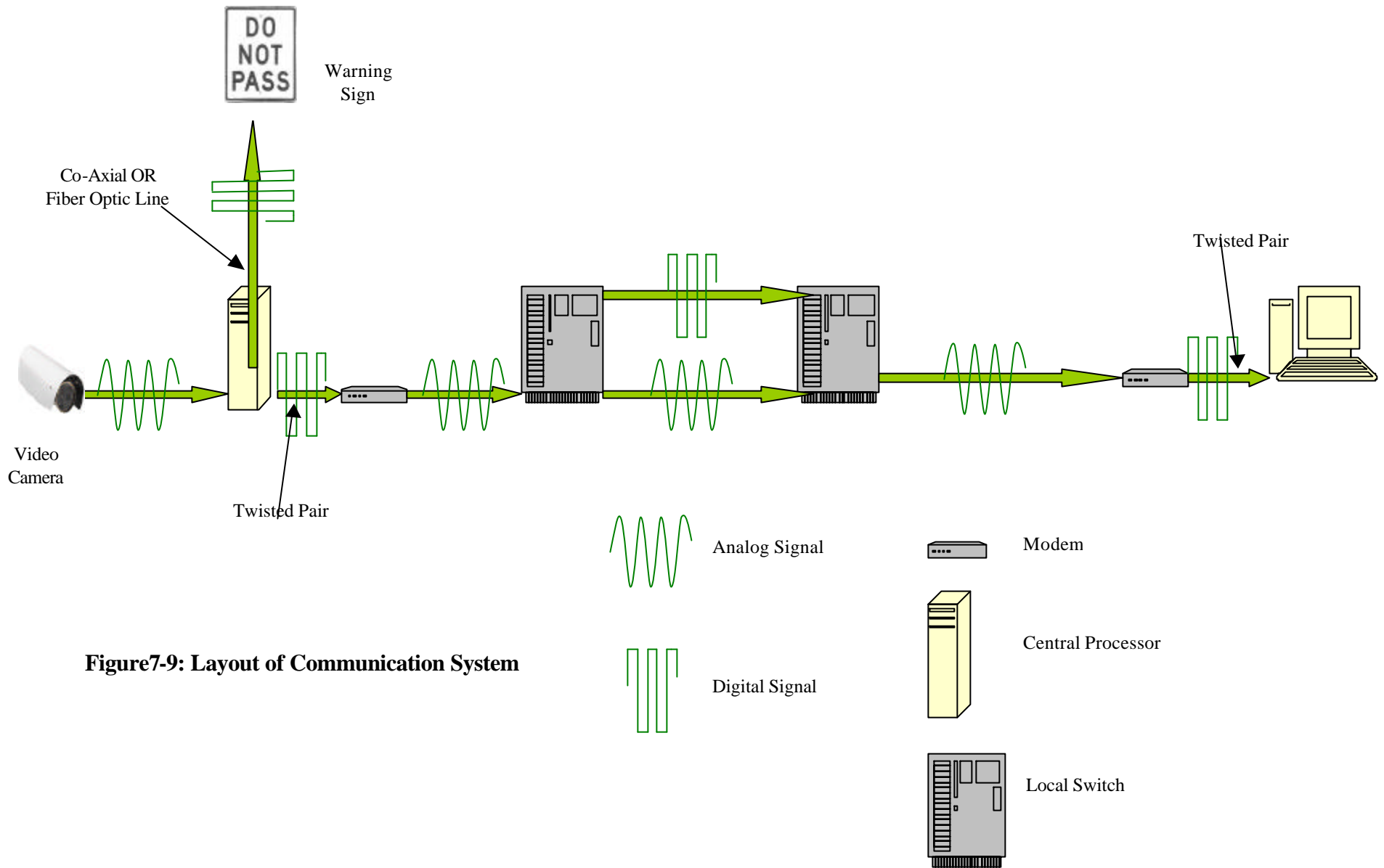

**Figure7-9: Layout of Communication System**



## **MVP Sensor**

- a. The MVP sensor shall operate at a maximum rate of 30 frames per second when configured for the NTSC (US) color video standard and 25 frames per second for the PAL (Euro) color video standard.
- b. The MVP sensor shall process a minimum of twenty detector zones placed anywhere in the field of view of the sensor.
- c. The MVP sensor shall be able to be programmed with a variety of detector types that perform specific functions.
- d. Detector Function combines outputs of multiple detectors via Boolean logic functions.

## **MVP Sensor External interfaces**

The external interfaces to the MVP sensor shall include:

- a. A detector port specifically to exchange detector state data with the or Solo Mini Hub, Detector Rack Card, Mini-Hub II, or Mini-Hub TS2.
- b. Differential color video out.
- c. 24 VAC/DC power to operate the sensor.

## **Supervisor Communications Port**

- a. There shall be a supervisor communications port to configure and provide general communications.
- b. The MVP sensor shall use an RS-485 multi-drop network protocol to facilitate communications via a network of Rack Cards, Mini Hubs, Mini-Hub IIs or Mini-Hub TS2s to a remote or local PC client/server application.
- c. The communications port shall allow the user to update the embedded software with a new software release and interact with a PC client/server application for all of the various detection requests supported by the MVP sensor.
- d. The communications protocol over the supervisor communications port shall be the UDP/IP message packet and routing standard.
- e. This protocol shall be used throughout the field network of MVP sensors, Hubs and the host PC server application.

## **Communications Panel Requirements**

A communications panel shall be provided with each MVP sensor for installation. The communications panel shall provide:

- a. A terminal block for terminating power.
- b. Terminated, four twisted-pair wiring to the image sensor.

## **Detector I/O Port**

- a. The MVP sensor detector port shall provide a dedicated, RS-485, half-duplex interface between the MVP sensor and a detector port master such as a Rack Card, Mini Hub, Mini-Hub II, or Mini-Hub TS2.
- b. The real-time state of phase inputs shall be transmitted to the MVP sensor.
- c. The MVP sensor shall exchange input and output state data with the detector port master every 100 ms.
- d. The communications protocol shall be UDP/IP over the single twisted-pair wiring.
- e. A detector port master such as a Mini-Hub, Mini-Hub II, or Mini-Hub TS2 shall subsequently translate the detection states, in an electrically compatible manner, to a traffic signal controller:
  - (1) Single pin state outputs shall be applied by the interface card immediately upon receipt of the state change. Each on or off pulse shall be guaranteed a minimum pulse width of 100 ms.
  - (2) Speed outputs from 2 pins shall reflect the true output of the delay proportional to measured speed within  $\pm 1$  ms.

## **Differential Video**

- a. The MVP sensor shall output full motion video using a differential video port in either NTSC or PAL format.
- b. The differential video shall be transmitted over a single twisted pair.

## **Power**

- a. The MVP sensor shall operate on 24 VAC/DC, 50/60 Hz at a maximum of 25 watts.
- b. The camera and processor electronics shall consume a maximum of 10 watts.
- c. The remaining 15 watts shall support an enclosure heater.

### **Detection Zone Programming**

- a. Placement of detection zones shall be by means of a portable or desktop computer using the Windows 95, 98, Millenium, or Windows NT 4.0, or 2000 operating systems, a keyboard, and a mouse.
- b. The VGA monitor shall be able to show the detection zones superimposed on images of traffic scenes.
- c. The mouse and keyboard shall be used to:
  - (1) Place, size, and orient detection zones to provide optimal road coverage for vehicle detection.
  - (2) Modify detector parameters for site geometry to optimize performance.
  - (3) Edit previously defined detector configurations.
  - (4) Adjust the detection zone size and placement.
  - (5) Add detectors for additional traffic applications.
  - (6) Reprogram the sensor for different traffic applications, changes in installation site geometry, or traffic rerouting.

It shall be possible to:

- a. Download detector configurations from the computer to the MVP sensor.
- b. Upload the current detector configuration that is running in the MVP sensor.
- c. Back up detector configurations by saving them to the computer's removable or fixed disks.
- d. Perform the above upload, store, and retrieve functions for video snapshots of the MVP sensors' view.

### **Detection Zone Operation**

The MVP sensor real-time detection operation shall be verifiable through the following means:

- a. View the video output of the sensor with any standard video display device (monitor).
- b. The video output of the MVP sensor (differential twisted pair) shall be capable of selectively transmitting:
  - (1) Camera video only.
  - (2) Analog video overlaid with the current real-time detection state of each detector.

(3) Camera video with overlaid, scaled cross-hairs that are useful for aiming the sensor (during installation).

(4) Individual detectors shall have the option of being hidden.

c. Electrically monitor assigned contact closure pinouts from a detector port master such as a Mini Hub TS1 interface card, Mini-Hub TS2 interface card, Detector Rack interface card, or Mini-Hub II interface card. Each pin of an interface card shall have one associated LED output to reflect its output state.

d. View the associated output LED state on the detector port master:

(1) An LED shall be ON when its assigned detector output or signal controller phase input is on.

(2) An LED shall be OFF when its assigned detector or signal controller input is off.

### **MVP Sensor Electrical**

a. The video output of the MVP sensor shall be isolated from earth ground.

b. All video connections from the sensor to the interface panel shall also be isolated from earth ground.

c. The video output, communication, and power stages of the sensor shall include transient protection to prevent damage to the sensor due to voltage transients occurring on the cable leading from the MVP sensor to other field terminations.

d. Connections for video, communications and power shall be made to the image sensor using a single 18-pin circular metal shell connector (Bendix PT07C-14-18P or equivalent).

e. The mating cable shall use a right-angle shell.

f. The MVP sensor shall have passed requirements for and received the CE mark.

## **7.7 Image Capturing Subsystem**

A 35mm industrial camera assures the automated enforcement function of the system. The selection for the simplest system was based on the size and the nature of the project and on the relatively low cost of the subsystem compared to the other more sophisticated equipments (digital cameras for example). The use of 35-mm camera units has also the advantage of being

portable. That would enable the agency to use it at other places or even in different applications such as red light running at some intersections.

Automated enforcement systems equipped with 35-mm cameras produce both black and white and color photographs. Cameras are located in a special unit to protect them from the weather or vandalism and placed on the side of poles.

The camera system is typically connected to the system controller. When a violator is detected and verified, the central processor activates the automated enforcement system. Upon activation of the system, the camera takes at least two to three pictures showing violation progress as the vehicle is running in the wrong direction. The shots will be taken from the back of the violating vehicle showing the rear license plate of the vehicle. Time interval between two consecutive shots is about 1 second.

#### **7.7.1 Photographic Unit #PGU-35**

This 35mm outdoor camera unit is basically intended for use by investigative units where good film resolution is needed for personnel identification or to read vehicle license plate numbers, etc. The basic unit consists of a Minolta 35mm SLR camera with automatic film advance (Figure 7-10). The camera is foam-mounted inside a weather-tight welded aluminum case for noise and shock protection.

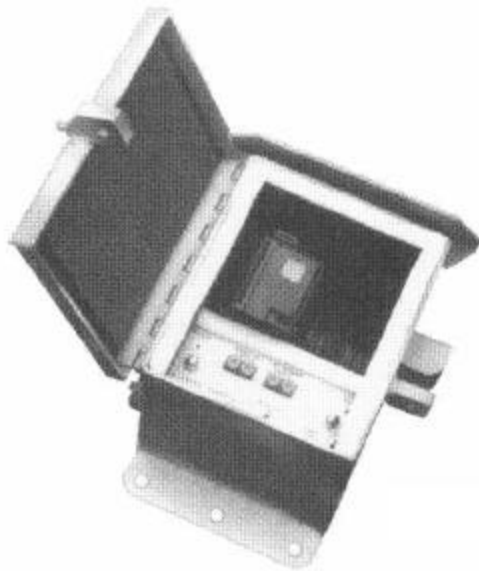

**Figure 7-10: 35mm License Plate Capturing Camera**

The case has mounting tabs and a lockable-hinged door. Housed inside the case is an electronic shutter control system that allows camera to be set up to take any number of photos from 1 to 36 at each tripping of detection circuit, with a varying time interval between photos upon the choice of the system manager. The camera comes with a Data Back that records on the photo the date or time that photo was taken. Also available as an option is an infrared or Radio Remote Trigger with a 250' range that removes the necessity of hard wiring the trigger cable to camera.

### **7.7.2 Camera Features**

Size: 17 cm x 15 cm x 19.5 cm.

Weight: Does not exceed 6.5 lbs.

Power: four AA batteries.

Built-in seismic and infrared detection electronics.

Telephoto and wide angle lense replacements.

Choice of number of photos taken per triggering.

Choice of time interval between photos from 1 second to 99 seconds.

External electronic triggering of photo sequence by grounding circuit or by using trail counter, vehicle detector or trip wires.

### **7.8 Offline Testing of The System**

Two offline field tests were conducted on December 7, 2000 and April 17, 2001 on Smart Road in Blacksburg, VA where Videotrak-910 system of Peek Traffic and Autoscope Solo system of Econolite were tested.

Video cameras equipped with power and video connections were installed on light poles distant about 360 feet at a height of about 35 feet. The cameras were 17-20 feet far from the right lane marking. The length of the road stretch covered by each camera was 300. The cameras were connected to a monitor via a control processor to direct, pinpoint and focus on appropriate field of vision. After the field of vision has been calibrated, VideoTrak and Autoscope software under Windows allow inputting the video image into a laptop by which the can interactively setup the size, shape and number of detection zones.



**Figure7-11: System Installation**

The laptop helps also as an interface when to:

- 1- Program the control processor to perform certain functions (such as traffic count, classification, speed, wrong way,...etc).
- 2- Adjust and calibrate the sensitivity of detection, or
- 3- View and monitor the facility video image from the control center.

Figures 7-11 (a-d) show the installation and calibration of system hardware and software in Videotrak field test. By simple dragging of the mouse over the input video image, an operator can draw the detection zones required. Each camera has the capability to accommodate up to

32 detection zones. Once detection zones are set, and their functions are programmed, the operator can verify visually how well the detection is functioning, and could view the detection zones blinking once they are actuated by an incident. Figure 7-12 shows that each lane was treated separately in order to test the system capability to detect violation in both directions by the same camera.

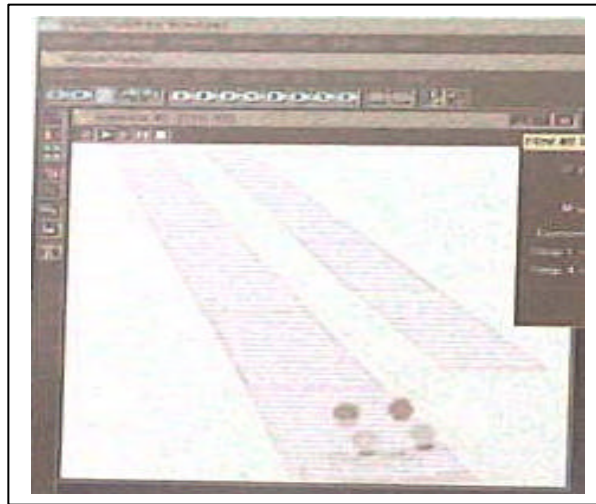

**Figure7-12: Detection Zones (Negative pictures)**

Four detection zones were drawn within the field of vision of one camera, two in each direction. The two detection zones falling in the same lane were programmed to detect traffic traversing opposite to the original direction of that lane.

The Autoscope detection zones are mainly constituted of one or more arrows as shown in Figure 7-13. These arrows could be drawn, enlarged and shifted by simple dragging of the mouse, and similarly they blink when they detect moving object within the detection zone.



**Figure7-13: Autoscope Detection Zones**



Finally, three types of vehicles participated in the field tests: a passenger car, SUV and trailer truck representing the vehicle classes defined in this research. Every vehicle type made several forth and back maneuvers in both directions.



(a)



(b)

**Figure7-14: Passing And Left Turn Tests**

In addition, some other maneuvers were tested: quick crossing of centerline and return simulating illegal passing, and left turns maneuvers simulating driveways in and out. Moreover, an additional test was made for non-motorized motions (such as pedestrians) to the long of the detection zones. Figures 7-14 (a & b) show some features of the offline field tests.

One additional test was conducted for Econolite system, specifically for the Boolean logic module. This test was made to detect violator and specify his speed at the moment when the wrong way direction is activated. This could happen by setting two different types of sensors, one rectangular sensor for measuring speed and the other arrow sensor for detecting violations. This feature would facilitate the data collection effort once the system is installed. Figure 7-15 shows the type of sensors used for this test.



**Figure7-15: Autoscope Boolean Feature**

### 7.8.1 Field Test results

- Both systems were successfully capable of detecting and confirming the wrong way violation. The violations detected were either by driving straight in opposite direction along the left lane, and by a fast violation maneuver from the right to left lane then returning to the right (simulating the illegal passing).
- Similar tests were made overnight in Smart Road with no lighting (see figures 7-16 a, b). The system showed similar success in detecting the wrong way incidents.



(a)

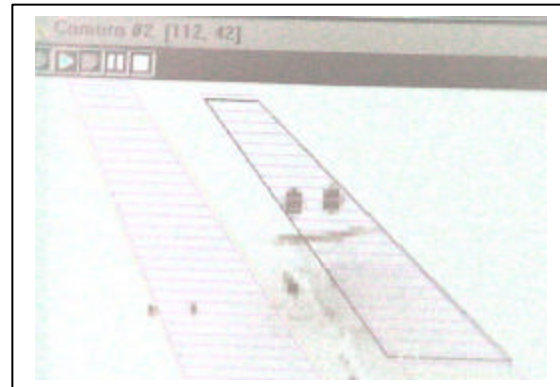

(b)

**Figure7-16: Nighttime Field Tests**

However some shortcomings have been observed in both systems, namely:

- 1- Small “objects” moving within the detection zones frame (such as animals or people) were detected by the system while walking in the middle of the road oppositely to the

original direction of the lane, which triggered false warning. That problem could be overcome by specifying a minimum number of varying pixels when the system compares and analyzes those in three consecutive pictures to verify and confirm the occurrence of a violation.

- 2- The problem of occlusion was clearly identified when the trailer truck was running in the right lane to the side of the camera pole. The height of the trailer was shadowing the area of the other lane, which leads to a false actuation of the detection zones (see figure 7-17 a, b).

This problem could be overcome either by:

- a. Installing two cameras each to detect one side of the road which means doubling the number of the cameras required to cover the same area (4 additional camera poles in our case), or
- b. Pushing the camera pole closer to the pavement edge and raising the camera to a higher altitude. Since there are standards that limit the nearest distance of fixed pole to the side of the road (30 feet from lane edge), it was found that the height needed to overcome the occlusion problem of trailer was about 100 feet pole height.



(a)

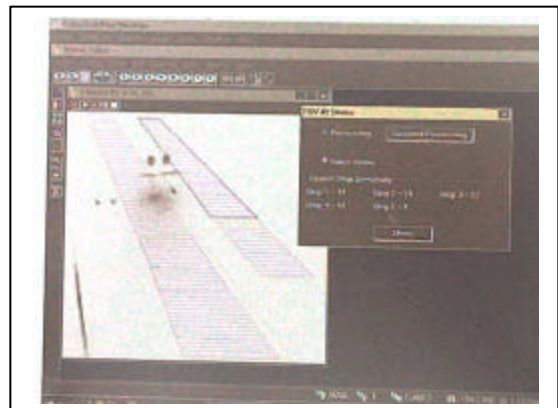

(b)

**Figure7-17: Occlusion Problem Tested in Field**

- c. Finally, Extending the mast above the road, typically to the road centerline. This solution was found the most appropriate because it does require neither modification in poles height additional, nor additional costs.

3- The third shortcoming is of special type of problems that characterizes our kind of “rural” road stretch: the in and out left turns to and from the driveways. This problem could have not been found in a typical rural road, where there is no access to the abutting land. Moreover, this problem could not have been faced if the left turns are performed perpendicular to the immediate lane axis. Unfortunately, this is not the real life case.

Practically, one solution found for such problem was to leave gaps at driveway locations among the detection zones of the immediate lane. The drawback of such solution will be on the overall system detection performance, because such arrangement will leave some spots undetected by the system, which might delay the response time to actuate detection and trigger the warning message.

4- As one test was conducted in an inclement weather, it was found that occasional false detections were displayed when the wind speed was high enough to shake the camera, thus moving back and forth the whole picture of the camera.

To overcome this problem, designer should take into consideration the weather history of the weather site in order to choose and install the appropriate rigid pole and the proper arm and fixation of the camera.