

# A LoRa sensor network for monitoring pastured livestock location and activity<sup>1</sup>

B.R. dos Reis,<sup>†</sup> Z. Easton,<sup>‡</sup> R.R. White,<sup>†,2</sup> and D. Fuka<sup>‡</sup>

<sup>†</sup>Department of Animal and Poultry Sciences, Virginia Tech, Blacksburg, VA 24073; and <sup>‡</sup>Department of Biological Systems Engineering, Virginia Tech, Blacksburg, VA 24073

**ABSTRACT:** Precision technologies for confinement animal agricultural systems have increased rapidly over the past decade, though precision technology solutions for pastured livestock remain limited. There are a number of reasons for this limited expansion of technologies for pastured animals, including networking availability and reliability, power requirements, and expense, among others. The objective of this work was to demonstrate a rapidly deployable long-range radio (LoRa) based, low-cost sensor suite that can be used to track location and activity of pastured livestock. The sensor is comprised of an inexpensive Arduino-compatible microprocessor, a generic MPU-9250 motion sensor which contains a 3-axis accelerometer, 3-axis magnetometer, and a 3-axis gyroscope, a generic GPS receiver, and a RFM95W generic LoRa radio. The microprocessor can be programmed flexibly using the open source Arduino IDE software to adjust the frequency of sampling, the data packet to send, and what conditions are needed to operate. The

LoRa radio transmits to a Dragino LoRa gateway which can also be flexibly programmed through the Arduino IDE software to send data to local storage or, in cases where a web or cellular connection is available, to cloud storage. The sensor was powered using a USB cord connected to a 3,350 mAh lithium-ion battery pack. The Dragino gateway was programmed to upload data to the ThingSpeak IoT application programming interface for data storage, handling, and visualization. Evaluations showed minimal benefit associated with reducing sampling frequency as a strategy to preserve battery life. Packet loss ranged from 40% to 60%. In a 3 d evaluation on pastured sheep, the sensor suite was able to report GPS locations, inertial sensor readings, and temperature. Preliminary demonstrations of our system are satisfactory to detect animal location based on GPS data in real-time. This system has clear utility as a lower-cost strategy to deploy flexible, useful precision technologies for pasture-based livestock species.

**Key words:** connectivity, extensive system, intensive system, LoRa, networking, precision technology, sensor

© The Author(s) 2021. Published by Oxford University Press on behalf of the American Society of Animal Science.

This is an Open Access article distributed under the terms of the Creative Commons Attribution-NonCommercial License (<http://creativecommons.org/licenses/by-nc/4.0/>), which permits non-commercial re-use, distribution, and reproduction in any medium, provided the original work is properly cited. For commercial re-use, please contact [journals.permissions@oup.com](mailto:journals.permissions@oup.com)

Transl. Anim. Sci. 2021.5:1-9

doi: 10.1093/tas/txab010

<sup>1</sup>Funding for this work was provided by The Pratt Endowment at Virginia Tech, and from funding and resources appropriated to the Virginia Agricultural Experiment Station.

<sup>2</sup>Corresponding author: [rwhite@vt.edu](mailto:rwhite@vt.edu)

Received November 9, 2020.

Accepted January 21, 2021.

## INTRODUCTION

Over the past decade, there has been tremendous expansion of wearable precision technology options for livestock in confinement settings (Neethirajan, 2017). These technologies provide the benefit of yielding individual data on

group-housed animals and can be used to enhance animal welfare (Halachmi et al., 2019), health (Rodgers et al., 2015), and productivity (Koltes et al., 2018). Moreover, wearable sensor technologies provide the possibility of remotely managing individual animals facilitating urgent interventions, responding to time and labor-intensive concerns in a more efficient manner (dos Reis et al., 2020). In order for these benefits to be fully realized, however, real-time communication to the farmer is essential (Kwong, et al., 2012).

A diversity of commercial systems that track and monitor livestock behavior are available, including Moovement, 2020, Herddogg, 2020, The CowManager System, 2020. Typically, these technologies rely on WiFi or Bluetooth connectivity for data transmission, which is sensible because they are predominantly designed for confinement-based operations where the system requires high-density, low distance data transmissions. Although these systems are commercially available, they have a number of challenges including high initial cost, difficulty in data interpretation, lack of clarity on data ownership, and unclear accuracy of their analytics approaches (dos Reis et al., 2020).

Confinement animal operations have the benefit of close physical proximity between managers, safe handling facilities, and animals, such that animals can easily be handled to replace lost wearable technologies, or to change out batteries, etc. In extensive livestock production systems, the lack of access to networking, handling facilities, and regular animal contact presents a barrier to effective use of these technologies. In order for wearable sensors to be more practical for extensive management settings, they must: 1) network over longer distances; 2) have reliable (and preferably renewable) power supplies; and 3) be low-cost so that damaged and lost sensors are less economically impactful; 4) must have data being transmitted in real-time. The expansion of the Internet of Things (IoT) movement across industry sectors provides numerous solutions to these four challenges. Numerous IoT applications leverage Long Range Wide Area networks (LoRaWAN) which have capacity to transmit small data packages over long distances. This networking technology provides a reasonable alternative to WiFi or cellular networking solutions currently offered for extensive systems.

Similarly, IoT technologies regularly focus on low-power use with programmatic options to sleep technologies between readings, leverage low-power circuitry, and readily utilize renewable energy

sources such as solar. Exploring how these different low-power options can be incorporated into wearable livestock sensors may help address the power supply challenges associated with these technologies. Finally, IoT technologies have also invested in reducing the per-unit cost of individual boards and sensors to make them affordable as a hobby. Because these technologies are already relatively low-cost, they present a logical starting place for exploring alternative options for wearable sensors for extensive livestock production systems.

The objective of this work was to demonstrate and assess the practical limitations of an IoT-based wearable sensor network for extensive livestock production systems. We will describe the construction of individual wearable sensors, the coding required to collect and transmit data, the configuration of the LoRa base station, and the linkage of the base station to the ThingSpeak IoT application programming interface (API). All technologies and software are open-source and can be implemented with fairly limited training, making the system valuable for research and refinement efforts.

## MATERIALS AND METHODS

All animal work conducted in this study was approved by the Virginia Tech Animal Care and Use Committee (protocol no. 19–159).

### *System Overview*

The sensor suite included three primary elements: the wearable sensor, the gateway, and the cloud-based server. The sensor was comprised of an Arduino-compatible microprocessor (\$4), a generic MPU92/50 motion sensor (\$8) which contains a 3-axis accelerometer, 3-axis magnetometer, and a 3-axis gyroscope, a generic GPS receiver (\$5), and an RFM95W generic LoRa radio (\$7). The sensor was powered using a USB cord connected to a battery. The microprocessor was designed for flexible programming using the open-source Arduino Integrated Development Environment (IDE) software. The code can be adjusted to change the frequency of sampling, the data packet to send, and what conditions are needed to operate. The LoRa radio transmitted to a Dragino LoRa gateway (\$60) which was also flexibly programmed through the native configuration software provided by Dragino (Dragino Technology Co, Zhenzhen, China). The LoRa gateway was programmed to upload data to the ThingSpeak API (The MathWorks, Inc, Natick, MA) for data storage, handling, and visualization.

### Wearable Sensor Design

The central processing unit of the wearable sensor used an Arduino-compatible microprocessor with 32 kB of flash memory and 2 kB of static random access memory. The microcontroller weighs 7 g and is 18 mm by 45 mm in size. A mini-USB was used to connect the microcontroller to a computer during programming, and to connect the microcontroller to the power supply during data collection.

The wearable sensor was equipped with two sensing devices, a generic HiLetgo® MPU92/50 motion sensor, and a generic GP-20U7 GPS receiver. Regardless of the programmed communication frequency, the MPU9250 normal mode data output rates are 1 kHz for the gyroscope, 4 kHz for the accelerometer, and 8 Hz for the magnetometer (repetition rate). The Arduino code is used to control the communication rate between the microprocessor and the inertial measurement unit (IMU), meaning that the communication rate is flexible, dependent on the inputs of the user. In this example, the IMU was sampled at 100 Hz and averaged for the 15 s reporting intervals.

The MPU92/50 is, in principle, two chips. The first includes a 3-axis gyroscope and a 3-axis accelerometer (MPU-6500) and the second includes a 3-axis magnetometer (AK8963). The board requires a 3.3 V power supply, weighs 2.722 g, and is 15.4 mm by 25.5 mm in size. The microcontrollers leverage the Inter-integrated Circuit (I<sup>2</sup>C) protocol for communication between the microcontroller and various connected digital integrated circuits. This communication protocol enables multiple sensors to transmit data via the microcontroller using only two signal wires, one linking the clock signal and one linking the data signal. Using this I<sup>2</sup>C integration, the completed wearable sensor connected the analog 4 and 5 pins of the microcontroller to the clock and data signal pins on the MPU92/50, respectively (Figure 1).

The GPS receiver used in the wearable sensor was a 56-channel receiver with a positional accuracy of 2.5 m and a velocity accuracy of 0.1 m/s. The GP-20U7 has a navigation update rate of 1 Hz. The receiver uses a 3.3 V power supply, weighs 10 g, and is 18.4 mm square in size. The GPS receiver used a serial peripheral interface (SPI) data transmission and was linked to the microcontroller through the digital 5 pin (Figure 1).

The final component of the wearable sensor was an RMF95W LoRa radio. The radio operates at 915 MHz for U.S. transmission and is capable

of sending data packets up to 256 bytes. The radio requires a 3.3 V power supply, weighs 3 g, and is 16 mm square in size. The radio also leverages SPI communication to link with the microcontroller to facilitate the transfer of the data from the microcontroller out through an antenna (Figure 1).

A USB cord was used to connect the microcontroller to the battery (Figure 2). All other connections in Figure 1 were made using 1.0 mm (63% Tin, 27% lead, 1.8% Flux Rosin core) solder; 22 gauge, PVC insulated solid wire; and a Weller WLC100 40-W soldering iron.

### Programming the Wearable Sensor

Once constructed, the wearable sensors were programmed using the open-source Arduino IDE software (<https://www.arduino.cc/en/Main/Software>). The code used to program the sensors is included at <https://github.com/rrwhitevt/>

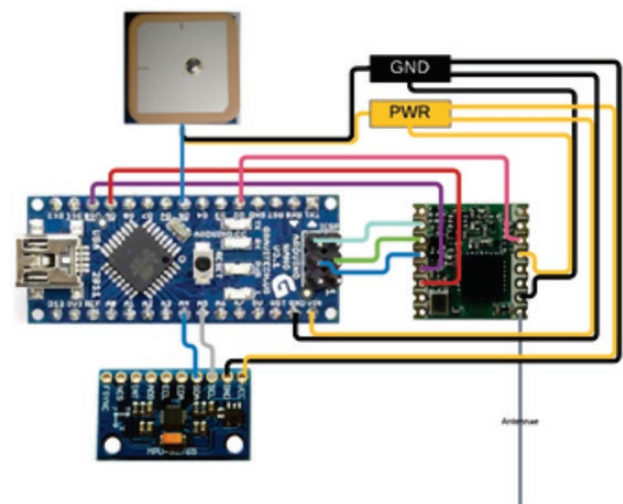

**Figure 1.** Pinout diagram for linkages among GPS sensor (top left), microprocessor (center left), motion sensor (bottom left), and LoRa radio (center, right). Wires are represented by different colors. All wires to and from the Power bus are represented in yellow and all wire to and from the Ground bus are represented in black.

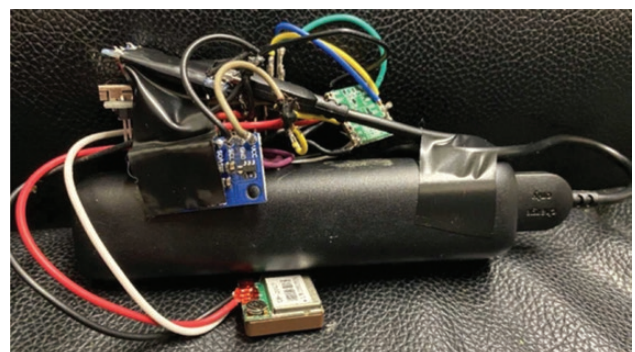

**Figure 2.** Constructed device used in the present study. Each sensor was 50 × 40 mm and weight 57.32 g.

**LoRa-Sensors.** In brief, Arduino code is broken down into three basic sections: code designed to be executed upon initialization; setup code; and looping code. Upon initialization of the microcontroller, the MPU92/50 and the GPS receiver were initialized based on the pinout used for sensor linkages (Figure 1). The maximum string length for strings sent via the radio driver was set to 250 characters and the serial baud was set to 9600. In the setup portion of the code, the serial communication between the LoRa radio and the microcontroller was initialized, as were the communication protocols with the GPS receiver and the MPU9250.

The loop code represents the activity of the microprocessor from setup until it is powered off. In this case, the loop code was designed to iterate at 100 Hz, meaning we can expect updated data to be sent from the sensor at that frequency. Each iteration, the microprocessor obtained the readings from each sensor. The  $x$ -,  $y$ -, and  $z$ -axes of the magnetometer, gyroscope, and accelerometer as well as the temperature reading were obtained from the MPU92/50. The latitude, longitude, and GPS timestamp (month, date, year, hour, minute, second) were obtained from the GPS receiver. These measurements were then retained in individual arrays until 15 s of data were collected, at which time the averages were computed and compressed into a single, comma delimited string. The data retrieval was done using the SoftwareSerial and SPI libraries of the Arduino IDE. The motion sensor data were interpreted using the MPU9250\_asukiaaa library and the GPS data were interpreted using the TinyGPSPlus library. Configuration and control of the LoRa receiver relied on the LoRa library utilities.

Flexibility in the functionality of the wearable sensor can be accomplished by changing a number of parameters within the code well as the frequency of sampling data. For example, the  $\text{delay}(t)$  statement at the end of the loop can be used to adjust

the reporting frequency of the sensor. To report more frequently,  $t$  should be reduced (1,000 = reporting every second, 10,000 = reporting every 10 s). Additionally, the `outString` can be adjusted to add or drop data from the reporting protocol. Finally, statements can be added before the delay statement to sleep the sensor between reads to help reduce power consumption.

### LoRa Gateway Setup

In Smart Farming environments, IoT technologies have previously been used to facilitate monitoring traceability in the value chain, which enables producers to optimize their production processes (Alonso et al., 2020). Within the agricultural context, LoRa being is a low-power, long-range wireless communication system which offers a good infrastructure for IoT (Augustin et al., 2016). The LoRa coverage range varies from 2 to 5 km in urban areas to 20–25 km in rural environments (Augustin et al., 2016), making this technology the most feasible for rural areas considering networking demands of at least 10 km in small-pasture. Several agricultural studies related to LoRa data transmission can be found in the literature. Li et al. (2018) collected vital signals of grazing cattle via LoRa network. Germani et al. (2019) demonstrated the use of LoRa networking to continuously monitor cattle located in barns and in pasture. Sadowski and Spachos (2020), comparing performance of between IoT devices, conclude that LoRa has the optimal technology to be used in an agricultural monitoring system.

Although there are several options for LoRa gateways to collect data packets sent out from the wearable sensors, we used the Dragino LG01-N Single Channel LoRa IoT Gateway for convenience. The gateway was installed in a barn at the Smithfield Farm 334 m away from the paddock where the animals were located. During initial setup, the gateway was connected using the wide-area network (WAN) port to a wired ethernet connection to be able to connect the device to the WiFi connection presented in the barn. After initial connection to this WiFi network, the gateway maintained WiFi connectivity (the wired connection was terminated) and it was powered throughout the experiment by connecting the device into an electric outlet. Following manufacturer specifications, the gateway was programmed to forward packets to ThingSpeak, an open-source IoT application used to store and retrieve data using the machine-to-machine IoT connectivity protocol (MQTT). Although this server system was used for demonstration, the

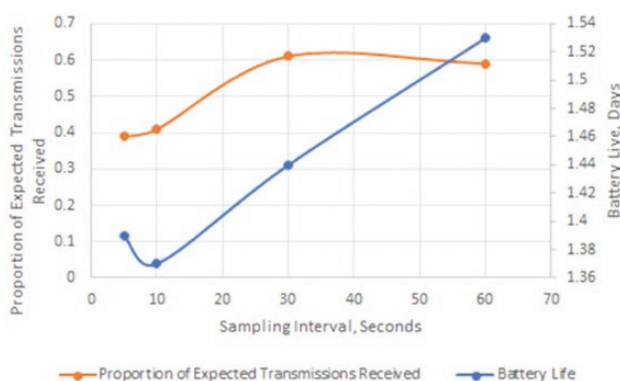

**Figure 3.** Data obtained from the sensor and the battery life in days with regard to sampling intervals in seconds.

network is compatible with other MQTT applications and other custom servers.

### Testing Sensor Network

The sensor network was tested for three performance attributes: battery life; signal repeatability; and data recovery. To test the battery life, sensors were charged to full capacity and allowed to exhaust at a sampling rate of once per 5, 10, 30, or 60 s. The length of signal reception was used to determine exactly when the battery was exhausted. To test signal repeatability, we compared the number of transmissions sent by the sensor to the number of transmissions logged in ThingSpeak at each transmission frequency. Finally, to evaluate the data recovery, we placed the sensor on test animals as described in the Experimental Testing section.

The experimental testing was conducted between July and October of 2020 at the Smithfield Farm, Virginia Polytechnic Institute and State University, Blacksburg, VA. The prototype sensors were placed on a neck-collar of adult crossbred Suffolk  $\times$  Dorset sheep (Figure 4), with an average weight of 70 kg (mean  $\pm$  SD  $\pm$  5 kg). Data were collected from animals in two different operating systems. In the first test, animals were housed individually in 10 ft  $\times$  3 ft cages. After the first period of raw data collection, animals were moved to a paddock (2.91 acres) in the same facility, in order to collect data in a grazing environment and analyze the performance of the sensor networking on transmitting data in a field scenario. A single prototype sensor was used during the intensive system trial to collect data for 3, 24-h sampling periods. After implementing some design updates to improve the durability and stability of the sensor casing, two prototype sensors were used to test performance



**Figure 4.** Experimental animal displaying the location and orientation of the device fitted on a collar.

in the extensive system. Again, data were collected for 3, 24 h sampling periods. The readings from the three-axis accelerometer, magnetometer, and gyroscope were reported as raw readings from the  $x$ -,  $y$ -, and  $z$ -axis of each measurement unit. The readings from the GPS receiver were also graphed as a heat map to detect patterns of where the animals were located when housed in the paddock.

## RESULTS AND DISCUSSION

### Wearable Sensor Deployments

Wearable sensors could be deployed in a variety of configurations including attached to animal collars, halters, or affixed directly to the animal leg or tail head. In each case, future work should be devoted to developing appropriately shaped housing for the sensors because sensor parts can easily be entangled in animal hair, components can easily be damaged by animals rubbing their heads on fences, trees, and other objects, and batteries should be kept out of contact with animals to minimize risk of animal exposure in the event that a battery explodes or catches fire. The appropriateness of the sensor design should be tailored to the species and use of the sensors for any particular study or end goal. In this study, we elected to enclose the sensors and batteries in a clear vinyl bag as this casing proved to be flexible, reasonably durable, and sufficiently waterproof to prevent damage to the sensors.

### Sensor Battery Life and Data Fidelity

Data obtained from the sensors showed that rapid sampling intervals had only marginal advantage in comparison to longer sampling intervals with respect to battery life (Figure 3). This is because the packages used to put the microprocessor into sleep mode between sampling events do not control all the sensors attached to the microprocessor, thus the main battery drain is still occurring, despite the microprocessor being placed in sleep mode. Changing the code to adjust the frequency of sampling to a less frequent sampling is an alternative to prevent the battery drain, which is a general challenge for the advancement of these sensor technologies because the frequency of sampling is highly correlated with the accuracy of the sensor and its power intensive. A battery with higher capacity is the simplest way to extend the battery-life, or to implement solar energy harvesting with a moderate capacity battery. Future work by our team is focused on comparing such strategies

for practicality, size/weight, device durability, and battery life. Irrespective of battery and energy harvesting advancements, future work is needed to simultaneously reduce the power requirement of sampling while maintaining the adequate level of accuracy for behavioral monitoring (Radeski and Ilieski, 2017).

The data fidelity testing showed that 40–60% of the transmitted packets were received and logged to the ThingSpeak network (Figure 2). This high rate of packet loss is likely due to the overloading of the system, which is better designed for more periodic transmissions (e.g., once per minute or less frequently). Future work should focus on developing strategies to obtain useful information from sensors with less frequent sampling intervals, and to evaluate the feasibility of designing custom servers for data housing.

### *Animal Behavioral and Location Data*

A major advantage of the sensor system deployed within this study is immediate capacity to monitor animal locations in real-time without calibration, interpretive algorithms, or further research. The use of Global positioning system (GPS) data has been well established in the research settings in order to track animal location (Turner et al., 2000; Handcock et al., 2009). More recently, GPS

measurements have been coupled with accelerometers for behavioral testing to better understand behavior and animal location concurrently (González et al., 2015; Bailey et al., 2018).

Although commercial sensors for animal GPS monitoring exist, there is a need for more flexible sensor designs and more affordable options for research and industry applications alike.

As shown in Figure 5, the sensors used in this study were able to provide detailed data on where individual animals spent their time within the pasture and how behaviors varied across a 24-h period. The tight clusters of points highlight areas where animals spend more time within the field. The 24-h data readings from the IMU also point to variation in how animals behave within the field throughout the day. Location-specific monitoring of animal velocity has previously been conducted for livestock (Trotter et al., 2010) and wildlife (Baratchi et al., 2013) in conjunction with GPS monitoring; however, most of these previous studies do not transmit data in real-time. Future work is needed to transition this real-time data transmission system to behavioral classification, rather than raw readings from IMU sensors, to better understand the geospatial distribution of animal behaviors in field environments.

Although algorithms have not yet been developed to translate raw IMU data obtained from

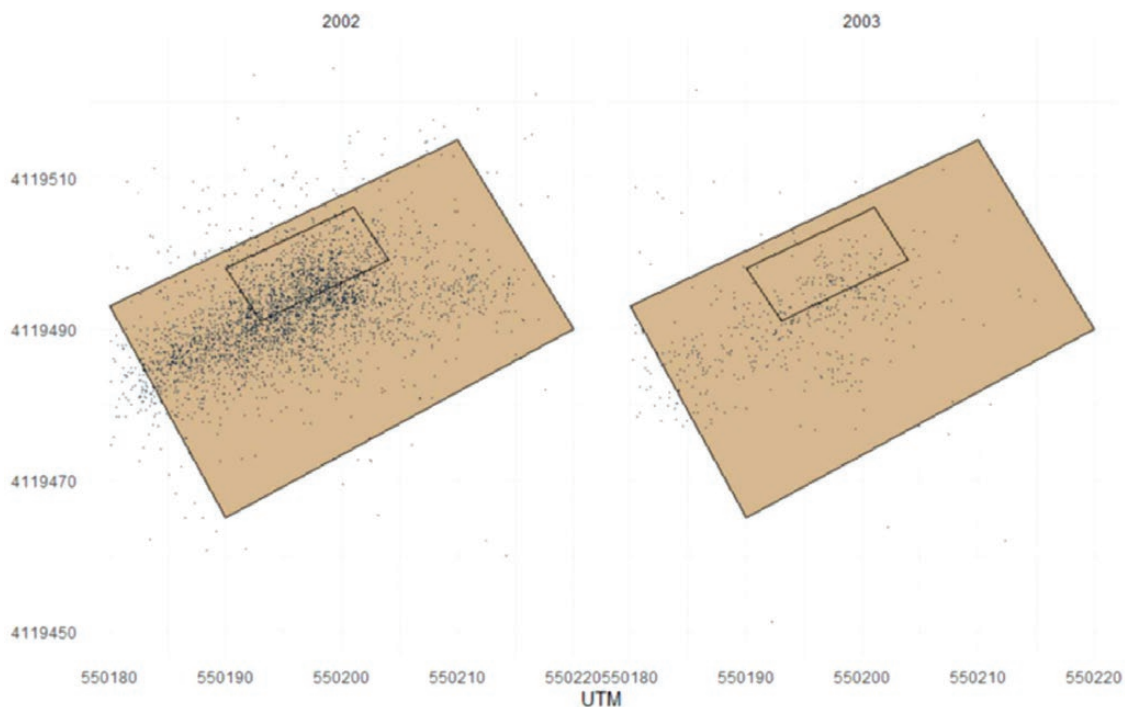

**Figure 5.** Comprehension of GPS location information for two animals over 24 h sampling period. The tan background reflects the pasture boundaries and the smaller black rectangle reflects the shedrow shelter in the pasture. The black dots represent the areas visited by the animals during the 24 h sampling.

this field sensor into meaningful animal behavioral classifications, the sensor's successful reporting of IMU data suggests future work in this area will expand the capacity of this low-cost, flexible tool for evaluation and real-time monitoring of grazing animal location and behaviors. For reference, the readings of the  $x$ ,  $y$ , and  $z$  axes data obtained from the IMU are reported in Figure 6. The acceleration signals produced are dependent on the activity being performed by the animal. Although no differentiation of the behavior's patterns are presented in the study, periods of inactivity and activity can be demonstrated by the behavior of the curves in Figure 6.

The real-time data transmission provided by the system is critical because its implementation may assist farmers to emergent situations such as exiting the field area, life-threatening threats, and emergent or time-sensitive health and management concerns. Collectively, this improved specificity and timeliness in management can reduce economic losses (Neethirajan, 2017) and contribute to enhanced animal productivity (dos Reis et al., 2020). As example, even in confinement settings, farmers often miss the signs of lameness, the disease second only to mastitis in terms of detrimental effects on dairy herd productivity (Booth et al., 2004), and accelerometer technologies have shown promise in detecting lameness (Chapinal et al., 2011). Specifically, Martiskainen

et al. (2009), used a three-dimensional accelerometer placed over the neck of dairy cows to identify lame walking with 65% sensitivity and 66% precision. Barwick et al. (2018) evaluating the ability of a tri-axial accelerometer sensor equipped with GPS attached in collar, ear and leg attached could classify lameness in sheep with an accuracy of 35%, 85%, and 82%, respectively. Transitioning these successes into the long-range, real-time data transmission paradigm highlighted by the technologies described in this work may help manager's better respond to lamenesses and other similar time-sensitive health challenges incurred by animals in the field.

Much like lameness detection, identification of estrus is a major challenge on most extensive livestock operations. In confinement systems, a biosensor collar has been used to detect estrus in cattle. For example, Shahriar et al. (2016), investigated the use of an accelerometer data collar to detect heat events in pastured dairy cows, and was able to achieve an overall accuracy of 82–100%. In a similar study using an ear-tag based sensor, Schweinzer et al. (2019) reported an estrus detection accuracy of 96%. Based on these previous studies, coupling appropriate analytics with the data obtained from the sensors described herein may facilitate detection of time-sensitive management challenges such as estrus behavior.

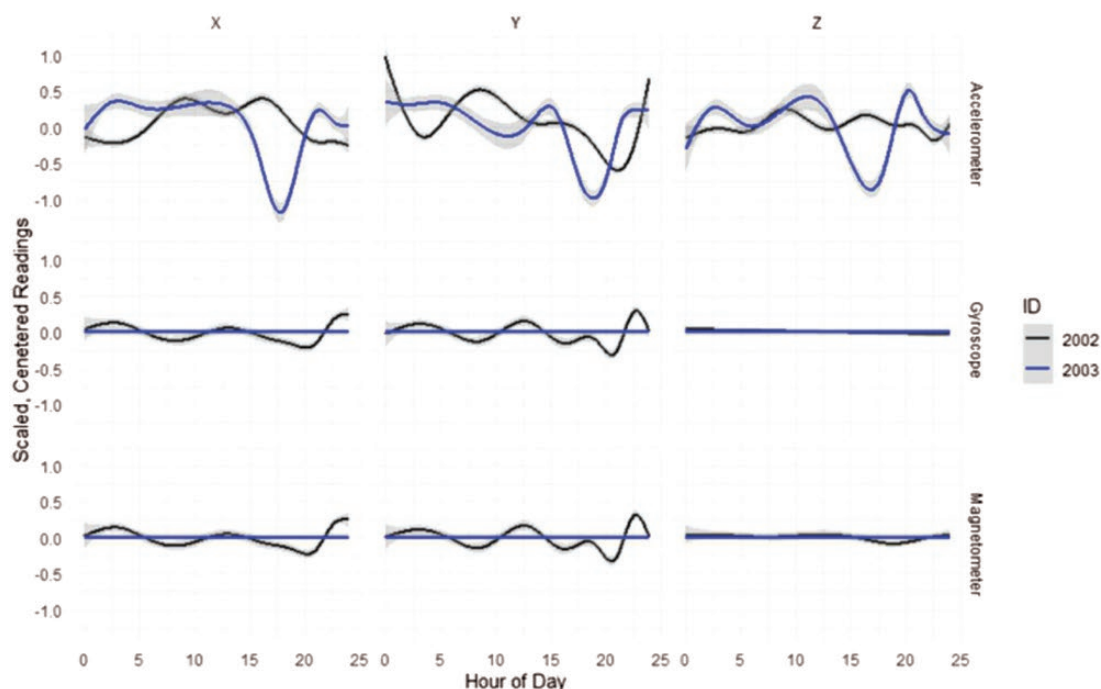

**Figure 6.** Smoothed, scaled, and centered readings of the  $x$ - $y$ - $z$  axes from the accelerometer, magnetometer, and gyroscope during 24-h period. Animal 2002 activity is represented by the black color, and the activity of the animal 2003 is presented by the blue color.

## CONCLUSIONS

In conclusion, the present study provides an overview of a flexible, rapidly deployable, and field-ready open source IoT sensor for monitoring behavior and location of livestock in extensive environments. Although only a very preliminary evaluation of geospatial characterization of environments experienced by grazing animals is provided, the usefulness of this research tool is highlighted. In future work, we expect this tool can be built upon to refine power requirements, optimize reporting frequencies, improve precision and accuracy of behavioral classification, and inform the update and advancement of commercial wearable IoT technologies for extensive production systems.

*Conflict of interest statement.* Authors of this manuscript declare no conflict of interest.

## LITERATURE CITED

- Alonso, R. S., I. Sittón-Candanedo, Ó. García, J. Prieto, and S. Rodríguez-González. 2020. An intelligent Edge-IoT platform for monitoring livestock and crops in a dairy farming scenario. *Ad. Hoc. Networks*. 98:102047. doi:[10.1016/j.adhoc.2019.102047](https://doi.org/10.1016/j.adhoc.2019.102047)
- Augustin, A., J. Yi, T. Clausen, and W. Townsley. 2016. A study of LoRa ora: long range & low power networks for the internet of things. *Sensors*. 16:1466. doi:[10.3390/s16091466](https://doi.org/10.3390/s16091466)
- Bailey, D. W., M. G. Trotter, C. W. Knight, and M. G. Thomas. 2018. Use of GPS tracking collars and accelerometers for rangeland livestock production research. *Transl. Anim. Sci.* 2:81–88. doi:[10.1093/tas/txx006](https://doi.org/10.1093/tas/txx006)
- Baratchi, M., N. Meratnia, P. J. Havinga, A. K. Skidmore, and B. A. Toxopeus. 2013. Sensing solutions for collecting spatio-temporal data for wildlife monitoring applications: a review. *Sensors (Basel)*. 13:6054–6088. doi:[10.3390/s130506054](https://doi.org/10.3390/s130506054)
- Barwick, J., D. Lamb, R. Dobos, D. Schneider, M. Welch, and M. Trotter. 2018. Predicting lameness in sheep activity using tri-axial acceleration signals. *Animals*. 8:12. doi:[10.3390/ani8010012](https://doi.org/10.3390/ani8010012)
- Booth, C. J., L. D. Warnick, Y. T. Gröhn, D. O. Maizon, C. L. Guard, and D. Janssen. 2004. Effect of lameness on culling in dairy cows. *J. Dairy Sci.* 87:4115–4122. doi:[10.3168/jds.S0022-0302\(04\)73554-7](https://doi.org/10.3168/jds.S0022-0302(04)73554-7)
- Chapinal, N., A. M. de Passillé, M. Pastell, L. Hänninen, L. Munksgaard, and J. Rushen. 2011. Measurement of acceleration while walking as an automated method for gait assessment in dairy cattle. *J. Dairy Sci.* 94:2895–2901. doi:[10.3168/jds.2010-3882](https://doi.org/10.3168/jds.2010-3882)
- CowManager. 2020. The CowManager System. Available from <https://www.cowmanager.com/en-us/>. Accessed October 28, 2020.
- Germani, L., V. Mecarelli, G. Baruffa, L. Rugini, and F. Frescura. 2019. An IoT architecture for continuous livestock monitoring using LoRa LPWAN. *Electronics*. 8:1435. doi:[10.3390/electronics8121435](https://doi.org/10.3390/electronics8121435)
- González, L. A., G. J. Bishop-Hurley, R. N. Handcock, and C. Crossman. 2015. Behavioral classification of data from collars containing motion sensors in grazing cattle. *Comput. Electron. Agricult.* 110:91–102. doi:[10.1016/j.compag.2014.10.018](https://doi.org/10.1016/j.compag.2014.10.018)
- Halachmi, I., M. Guarino, J. Bewley, and M. Pastell. 2019. Smart animal agriculture: application of real-time sensors to improve animal well-being and production. *Annu. Rev. Anim. Biosci.* 7:403–425. doi:[10.1146/annurev-animal-020518-114851](https://doi.org/10.1146/annurev-animal-020518-114851)
- Handcock, R. N., D. L. Swain, G. J. Bishop-Hurley, K. P. Patison, T. Wark, P. Valencia, P. Corke, and C. J. O'Neill. 2009. Monitoring animal behaviour and environmental interactions using wireless sensor networks, GPS collars and satellite remote sensing. *Sensors (Basel)*. 9:3586–3603. doi:[10.3390/s90503586](https://doi.org/10.3390/s90503586)
- HerdDogg®. 2020. Available from: <https://herddogg.com/>. Accessed December 14, 2020.
- Koltes, J. E., D. A. Koltes, B. E. Mote, J. Tucker, and D. S. Hubbell, III. 2018. Automated collection of heat stress data in livestock: new technologies and opportunities. *Transl. Anim. Sci.* 2:319–323. doi:[10.1093/tas/txy061](https://doi.org/10.1093/tas/txy061)
- Kwong, K. H. 2012. Practical considerations for wireless sensor networks in cattle monitoring applications. *Comput. Electron. Agricult.* 81:33–44.
- Li, Q., Z. Liu, and J. Xiao. 2018. A data collection collar for vital signs of cows on the grassland based on LoRa. In: 2018 IEEE 15th International Conference on e-Business Engineering (ICEBE). IEEE, Xi'an. p. 213–217. Available from: <https://ieeexplore.ieee.org/document/8592652>
- Martiskainen, P., M. Järvinen, J.-P. Skön, J. Tiirikainen, M. Kolehmainen, and J. Mononen. 2009. Cow behaviour pattern recognition using a three-dimensional accelerometer and support vector machines. *Appl. Anim. Behav. Sci.* 119:32–38. doi:[10.1016/j.applanim.2009.03.005](https://doi.org/10.1016/j.applanim.2009.03.005)
- Moovement. 2020. mOOvement. Available from: <https://www.moovement.com.au/>. Accessed December 14, 2020.
- Neethirajan, S. 2017. Recent advances in wearable sensors for animal health management. *Sensing Bio-Sensing Res.* 12:15–29. doi:[10.1016/j.sbsr.2016.11.004](https://doi.org/10.1016/j.sbsr.2016.11.004)
- Radeski, M., and V. Ilieski. 2017. Gait and posture discrimination in sheep using a tri-axial accelerometer. *Animal*. 11:1249–1257. doi:[10.1017/S175173111600255X](https://doi.org/10.1017/S175173111600255X)
- dos Reis, B. R., D. R. Fuka, Z. M. Easton, and R. R. White. 2020. An open-source research tool to study triaxial inertial sensors for monitoring selected behaviors in sheep. *Transl. Anim. Sci.* 4:txaa188. doi:[10.1093/tas/txaa188](https://doi.org/10.1093/tas/txaa188)
- Rodgers, M. M., V. M. Pai, and R. S. Conroy. 2015. Recent advances in wearable sensors for health monitoring. *IEEE Sensors J.* 15:3119–3126. doi:[10.1109/JSEN.2014.2357257](https://doi.org/10.1109/JSEN.2014.2357257)
- Sadowski, S., and P. Spachos. 2020. Wireless technologies for smart agricultural monitoring using internet of things devices with energy harvesting capabilities. *Comput. Electron. Agricult.* 172:105338. doi:[10.1016/j.compag.2020.105338](https://doi.org/10.1016/j.compag.2020.105338)
- Schweizer, V., E. Gusterer, P. Kanz, S. Krieger, D. Süß, L. Lidauer, A. Berger, F. Kickinger, M. Öhlschuster, W. Auer, et al. 2019. Evaluation of an ear-attached accelerometer for detecting estrus events in indoor housed

- dairy cows. *Theriogenology*. 130:19–25. doi:[10.1016/j.theriogenology.2019.02.038](https://doi.org/10.1016/j.theriogenology.2019.02.038)
- Shahriar, M. D. S., D. Smith, A. Rahman, M. Freeman, J. Hills, R. Rawnsley, D. Henry, and G. Bishop-Hurley. 2016. Detecting heat events in dairy cows using accelerometers and unsupervised learning. *Comput. Electron. Agricult.* 128:20–26. doi:[10.1016/j.compag.2016.08.009](https://doi.org/10.1016/j.compag.2016.08.009)
- Trotter, M. G., D. W. Lamb, G. N. Hinch, and C. N. Guppy. 2010. Global navigation satellite system livestock tracking: system development and data interpretation. *Anim. Prod. Sci.* 50:616. doi:[10.1071/AN09203](https://doi.org/10.1071/AN09203)
- Turner, L. W., M. C. Udall, B. T. Larson, and S. A. Shearer. 2000. Monitoring cattle behavior and pasture use with GPS and GIS. *Can. J. Anim. Sci.* 80:405–413. doi:[10.4141/A99-093](https://doi.org/10.4141/A99-093)