

**THE POSITION OF A CHAIR**  
SEAN PATRICK HAISLIP

**The Position of a Chair**

Sean Patrick Haislip

A thesis submitted to the Graduate Faculty  
of Virginia Polytechnic Institute and State  
University in partial fulfillment of the  
professional degree

Master of Architecture,  
in Architecture.

August 15th, 2013  
Blacksburg, Virginia

Steven R. Thompson

Patrick A. Doan

Kay F. Edge

Keywords  
Chair  
Steamed-Wood  
Construction  
Architecture

A chair was made of northern white ash wood. Steamed laminates make up each leg, and the spans are solid wood. A bent seat perches on this frame. Drawings, words, and photographs expose the chair in this book. A full exposition of the work can be found in the Art and Architecture Library at the College of Architecture and Urban Studies.

Sean Patrick Haislip  
The Position of a Chair



A \_ White ash laminates, digital photo

Preface / 01  
Construction / 03  
Situation / 36  
Admission / 41  
Index / 42  
Reference / 43

To Eugene and Wilson.

This thesis is concentrated on the making of a chair. Construction, not production, is essential to a thing that is built. There are multiple operations that allow a thing to be made. We accept that operations exist within language. This chair posits my interest in a language of construction. As men, we admit making requires not only a skill, but a spirit. It is here, we encounter architecture and begin to build.



B\_ Croffead House window, digital photo

The world is seen at a distance.  
To be present, is to have affection.  
A primal search reveals an ancestor.  
This is an operation of making.

A constructive thought is the nerve of an idea, but it is realized through its construction. It dictates a precise dimension and its structure, the selection of material. The nature of a constructive thought precedes the calculated reality, as the thought carries the totality of completion.

Per Olaf Fjeld  
Sverre Fehn: The Thought of Construction, P. 40

The moral act positions a figure.  
 To make, is to figure an act of man.  
 A line is drawn for a basic definition.

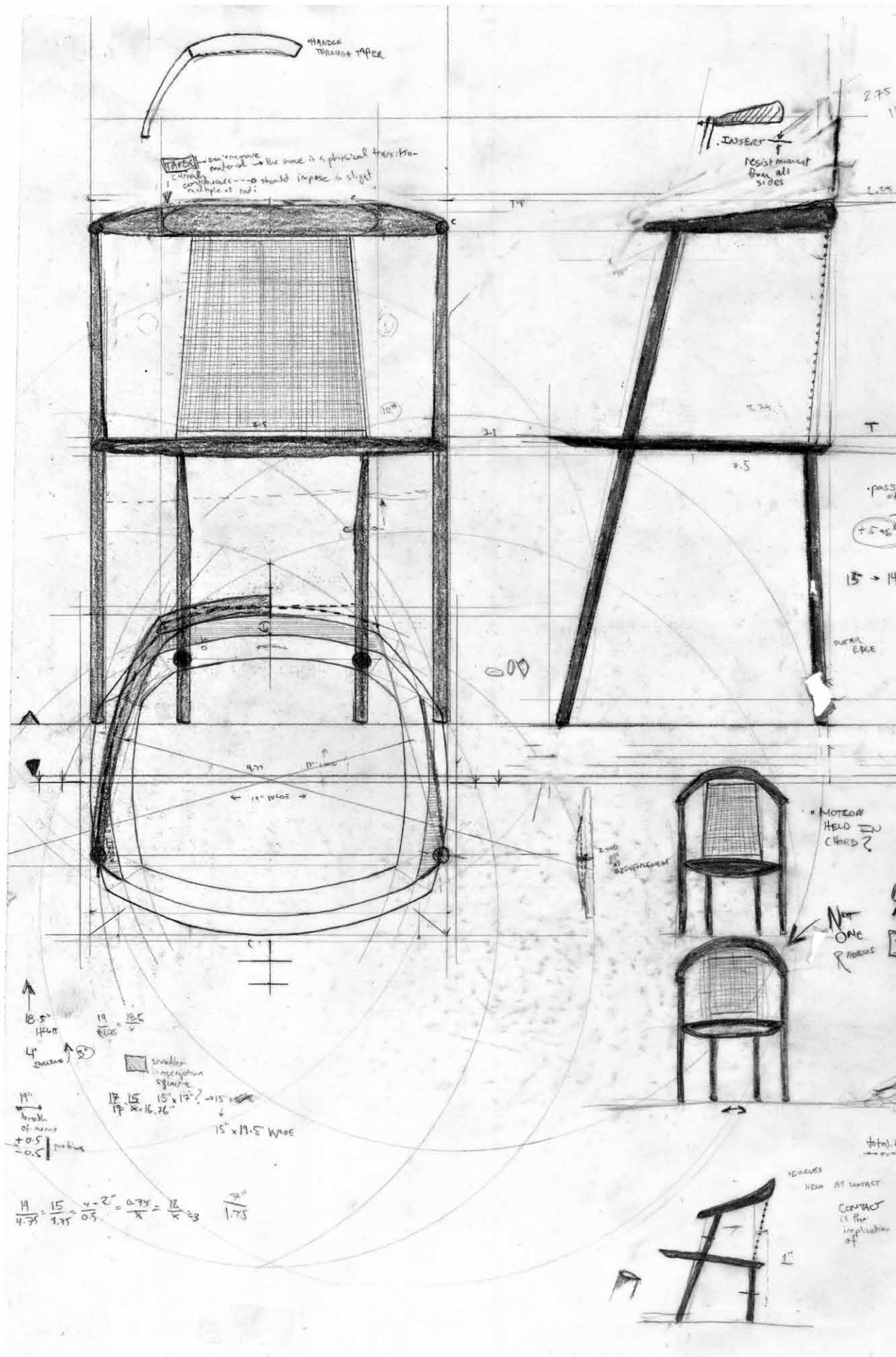



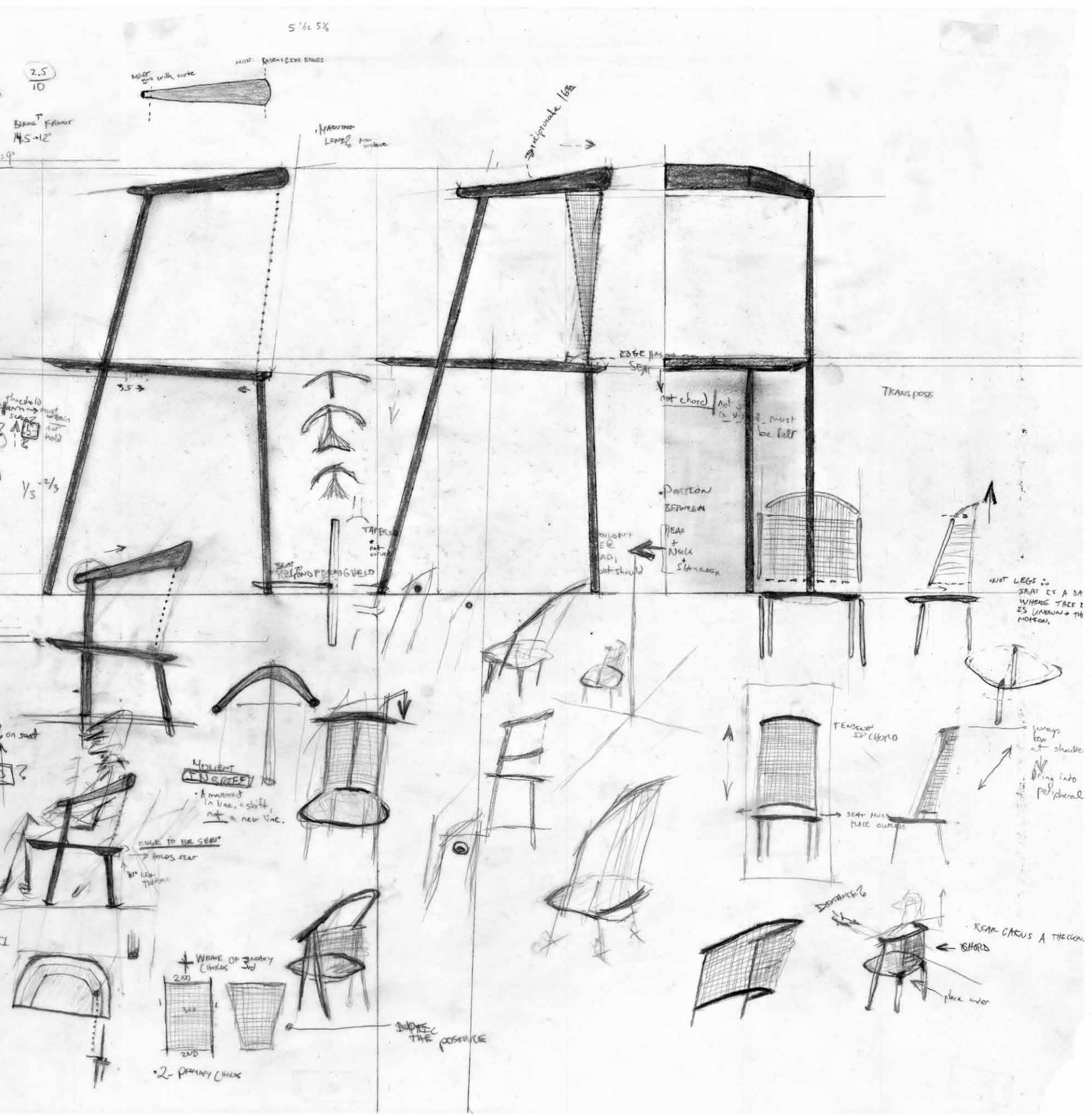

C \_ Figures of a chair, lead on trace paper

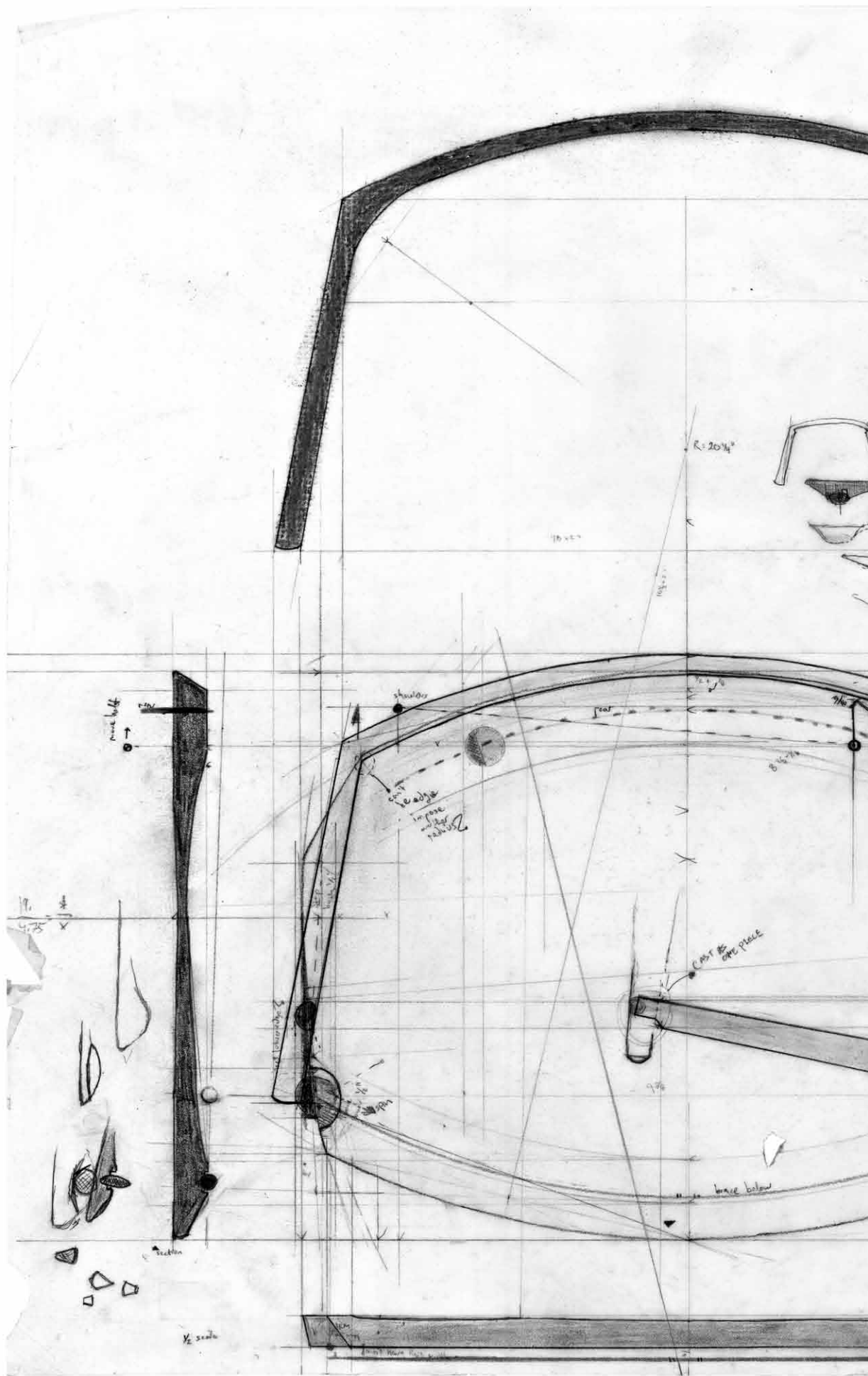

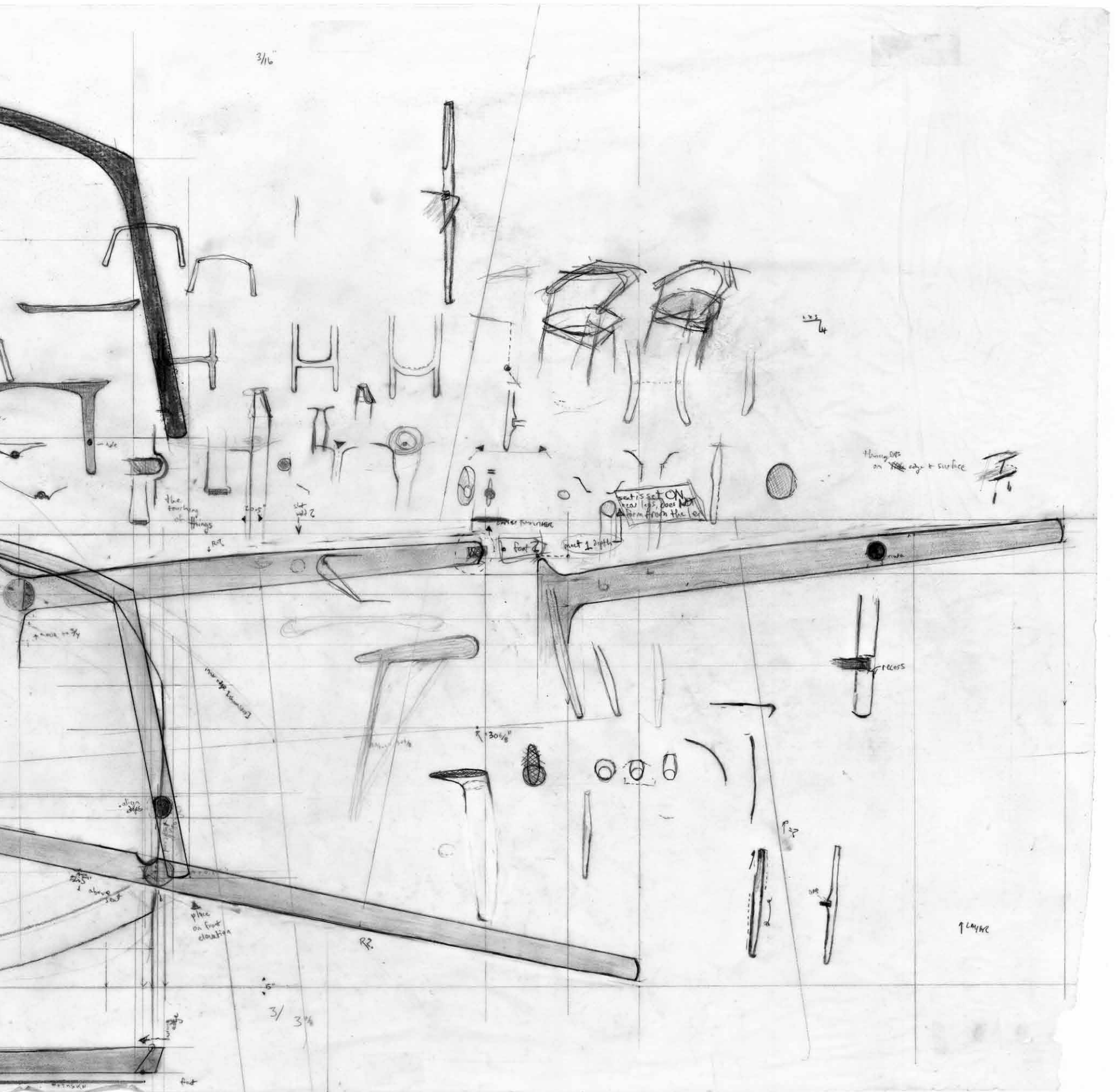

D \_ Cast chair projection, lead on trace paper



E \_ Initial cut layout, digital photo

Material informs what is made.  
White ash is in the chair's construction.  
This wood is present to a man's hand.  
Ash is accepted in the finish.



F \_ Rough laminate cut, digital photo, credit / Chris Taylor

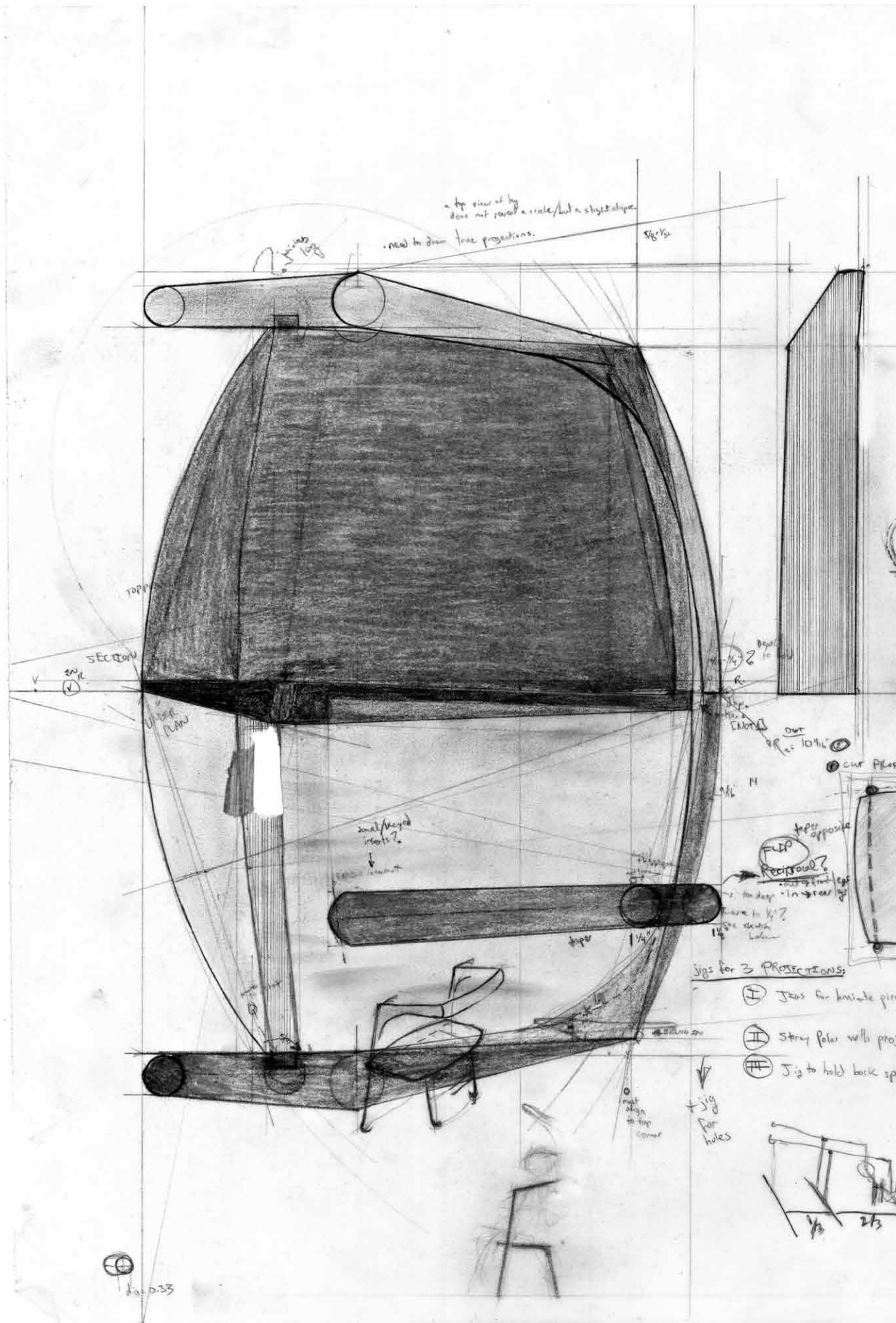

3/8"

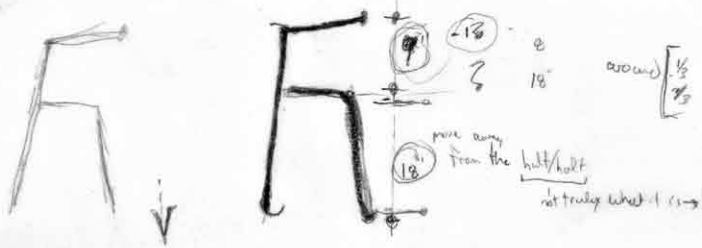

it truly what it is - but it leaves the impression actually and things as not appropriately patterned

9 LAYERS + FORM MEER

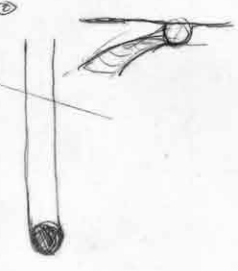
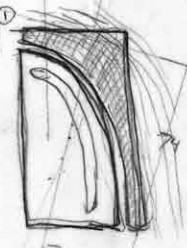
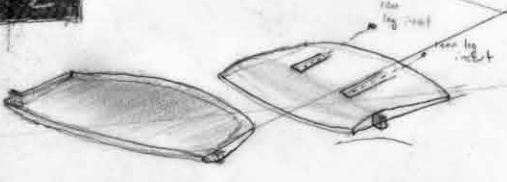
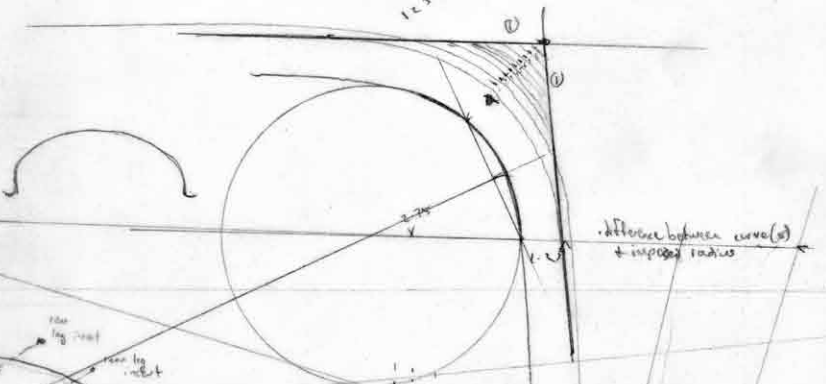

turn  
this deals with the movement of each piece and the physical joint away from the sitting hinge

for each side this deals with the shaping of each piece

on with legs as one piece

it will be finished as one, glue and caulked together

without joints

any jigs to run through router

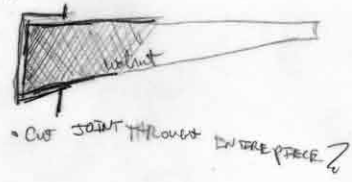
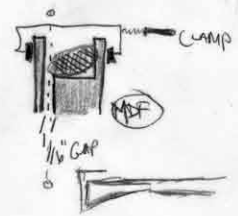
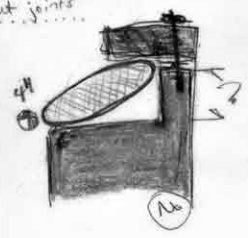

CLAMP

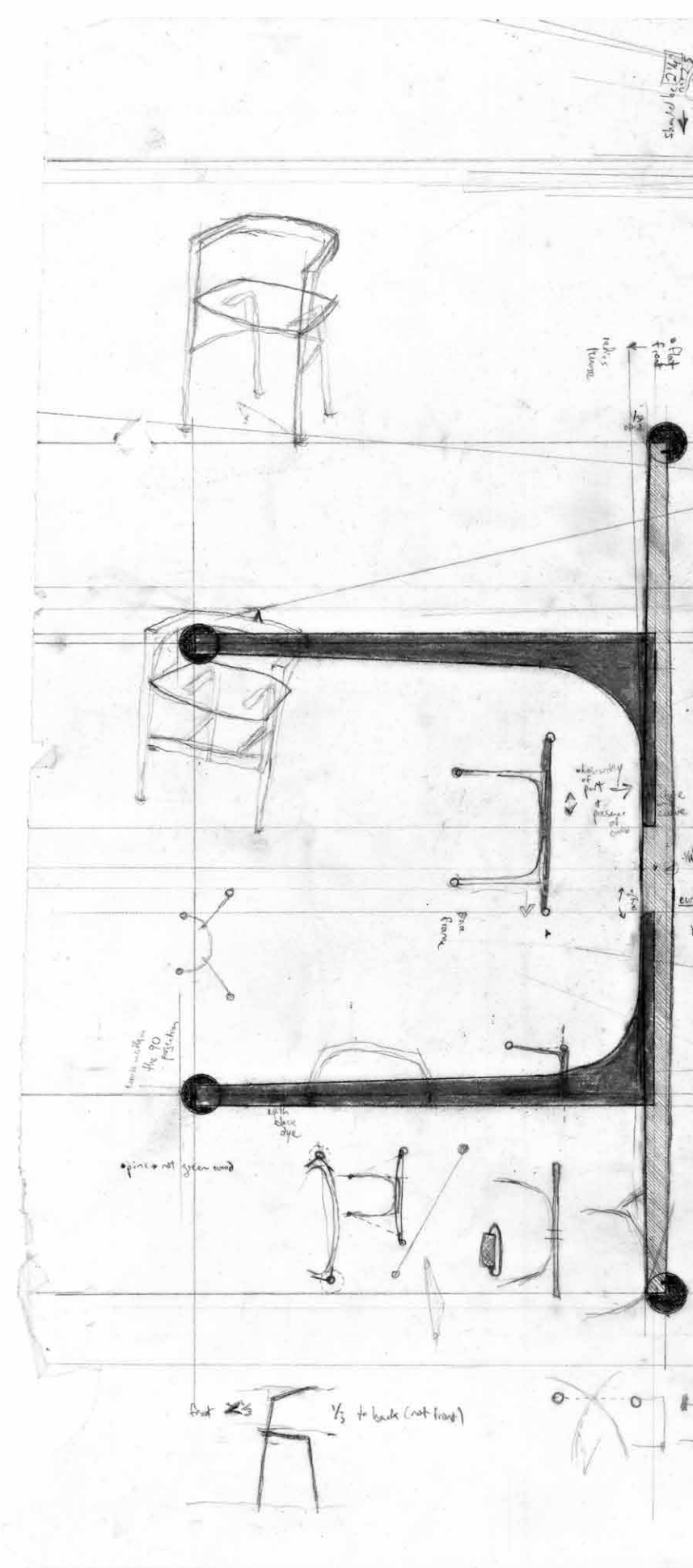



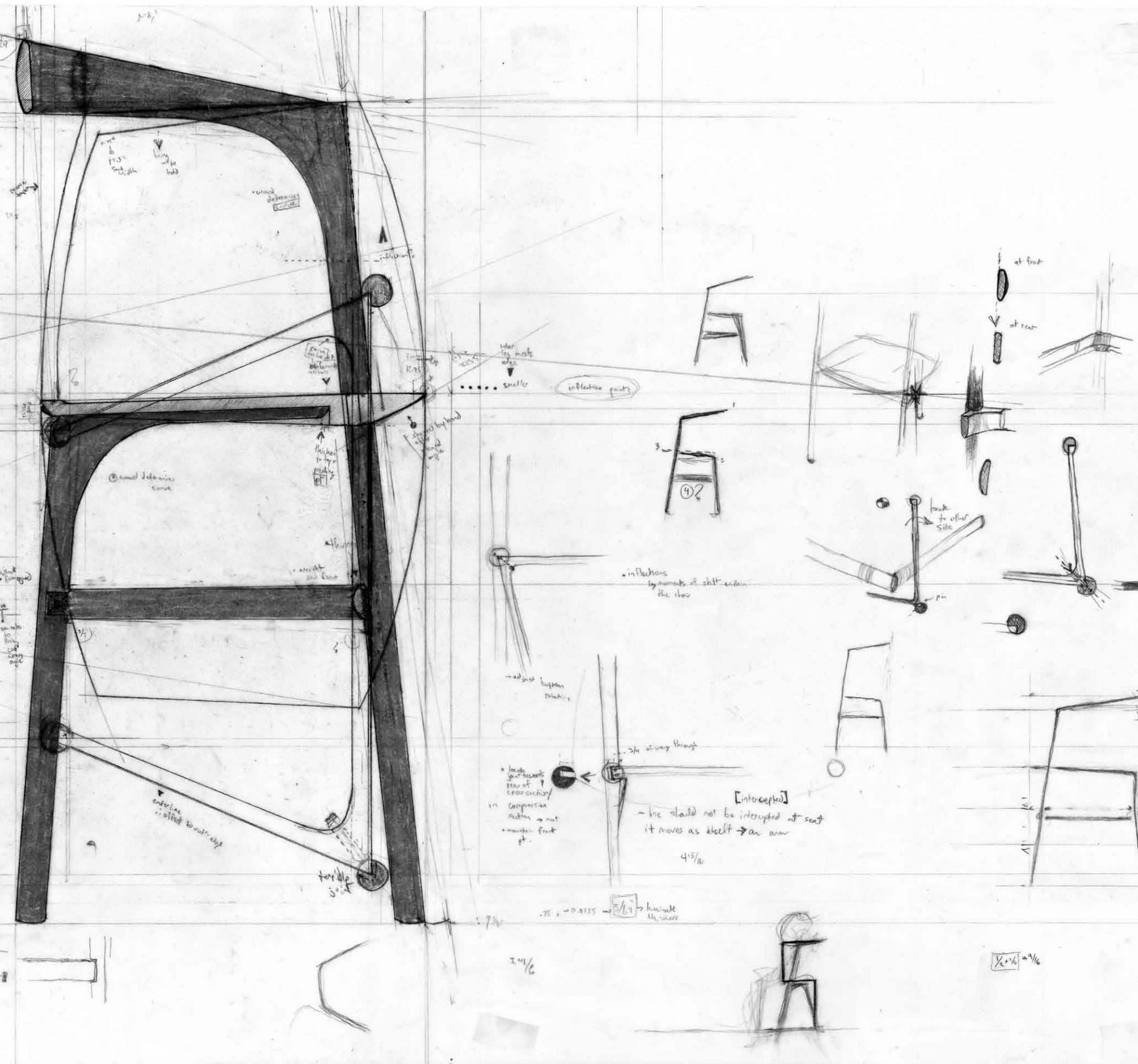

H \_ Lowered struts, lead on trace paper

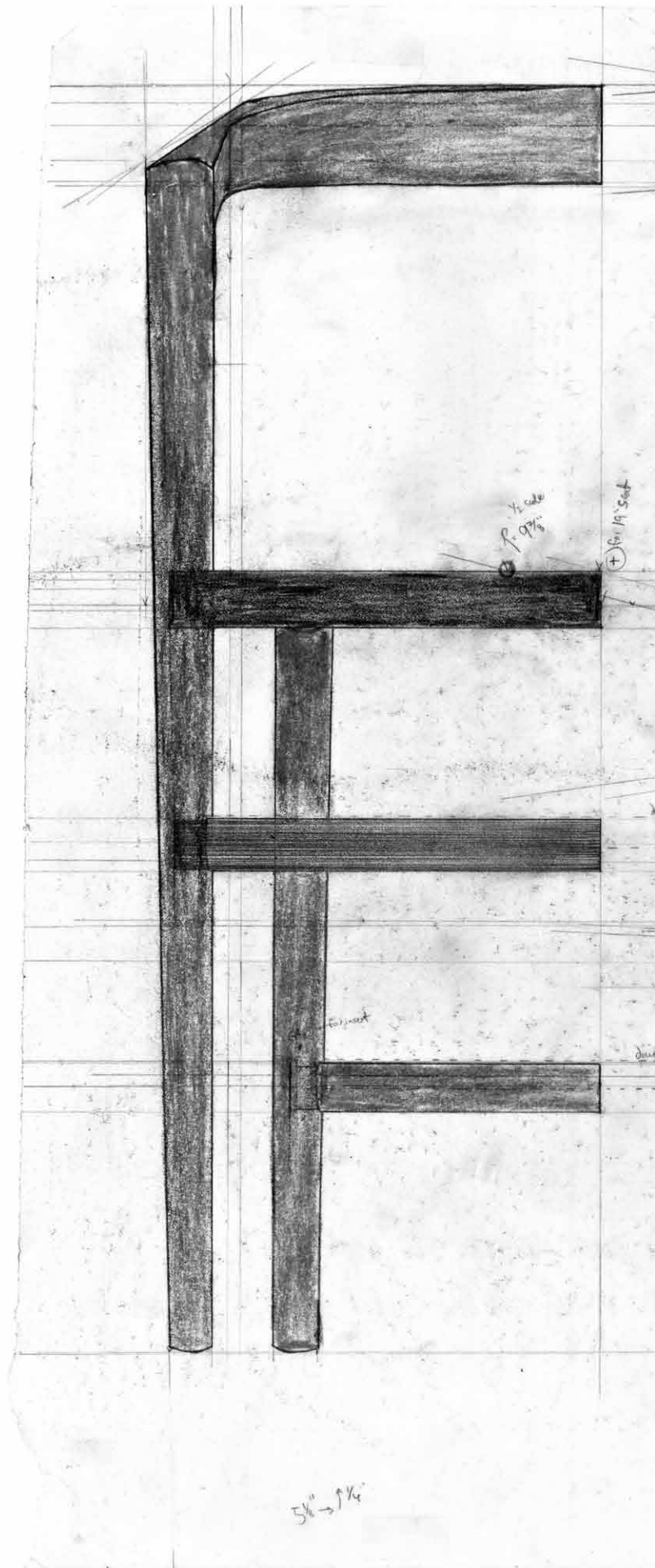

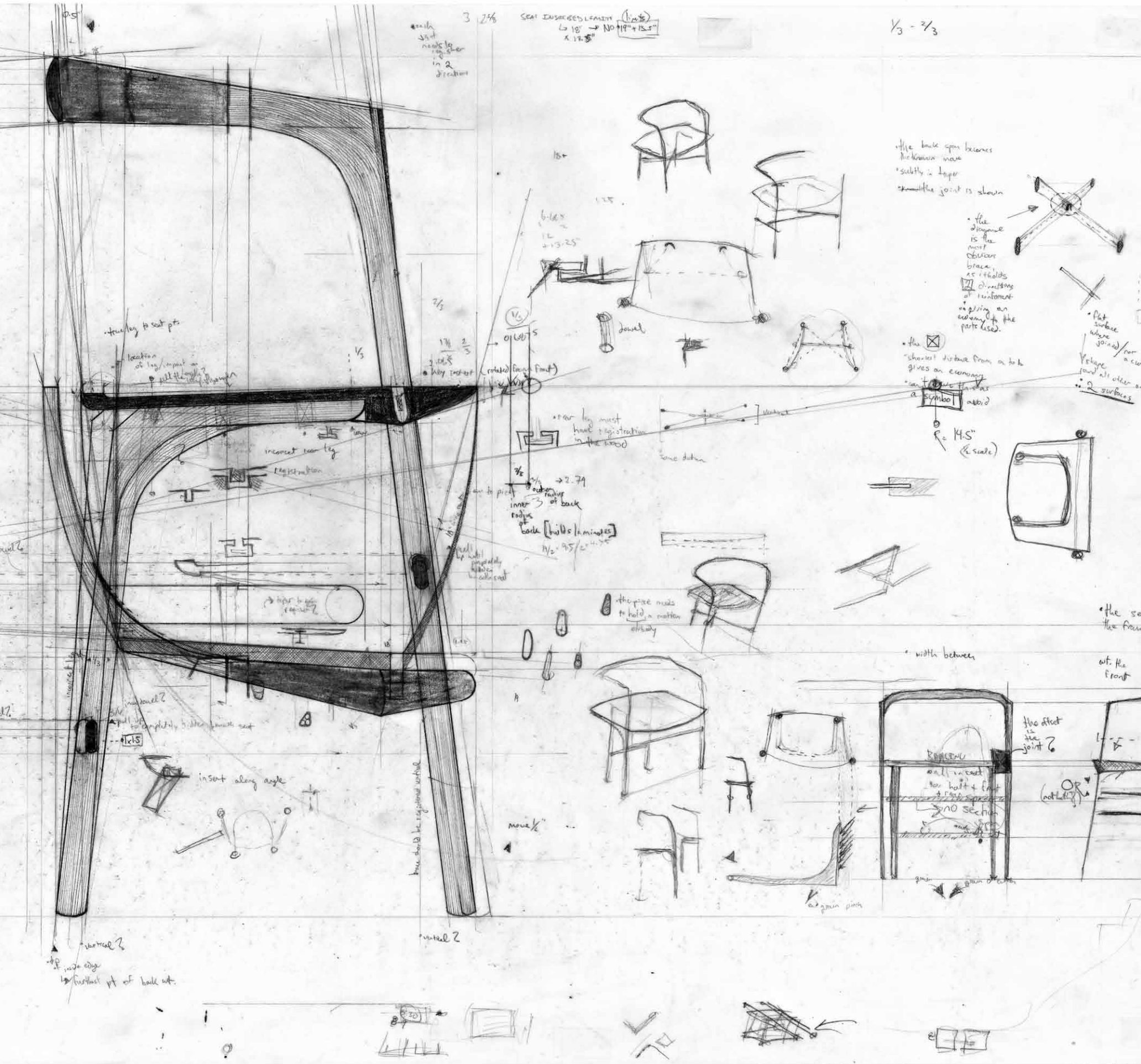

SEAT ENDS LEAD IN  
 L 18" → NO  
 x 17.5"

$\frac{1}{3} - \frac{2}{3}$

SEAT ENDS LEAD IN  
 18" → NO  
 x 17.5"

the back span becomes  
 unknown now  
 subtle is large  
 the joint is shown

the distance  
 is the most  
 obvious  
 brace  
 as it holds  
 the  
 directions  
 of movement  
 in a line an  
 across the  
 parts used.

the  $\times$   
 shortest distance from a to b  
 gives an economy  
 in materials  
 a symbol added

flat surface  
 where joints  
 are  
 shape  
 found all other  
 2 surfaces

$r = 14.5"$   
 (scale)

near leg must  
 have registration  
 in the wood

to pick  
 outer  
 inner  
 radii  
 of back  
 radii  
 of back (hills & minutes)  
 $\frac{1}{2} \times 9.5 = 4.75$

the piece needs  
 to hold a motion  
 already

width between

the so  
 the face

at the  
 front

the effect  
 in the  
 joint?

OR  
 (rotating)

these should be registered vertical

move  $\frac{1}{2}$

vertical?  
 1/2 x 15  
 pull out completely, better front cut

insert along angle

vertical?  
 1/2 x 15  
 pull out completely, better front cut

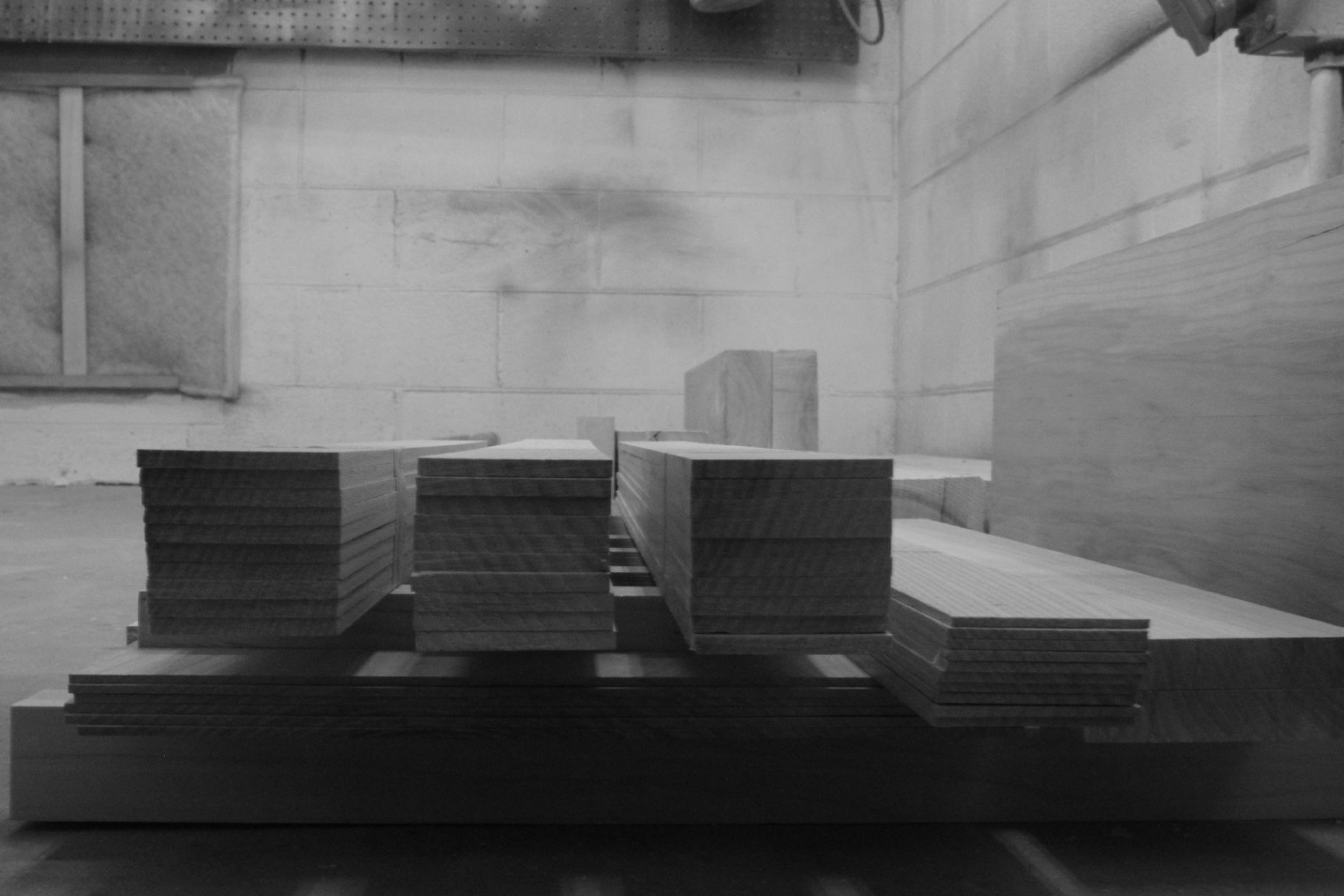

J\_ Wood cut for one chair, digital photo

Hyle is cut; Odysseus did this.  
Laminates possess the joint.  
Steam carries the curve.  
Span determines the frame.  
Definition is furnished in the figure.



K \_ Laminates bent for back, digital photo, credit / Chris Taylor



L \_ Steamed rear leg, digital photo



M\_ Laminate prepped for glue, digital photo, credit / Chris Taylor



N \_ Joint and chair models, digital photo

The frame is a setting.  
Tenure steps the anxious mind.  
There is a room to attend the feet.  
If in prayer, a table may be needed.

Here, the figure is drawn.  
This is a modest basis.  
It is drawn multiple times.  
An essential fact of construction.

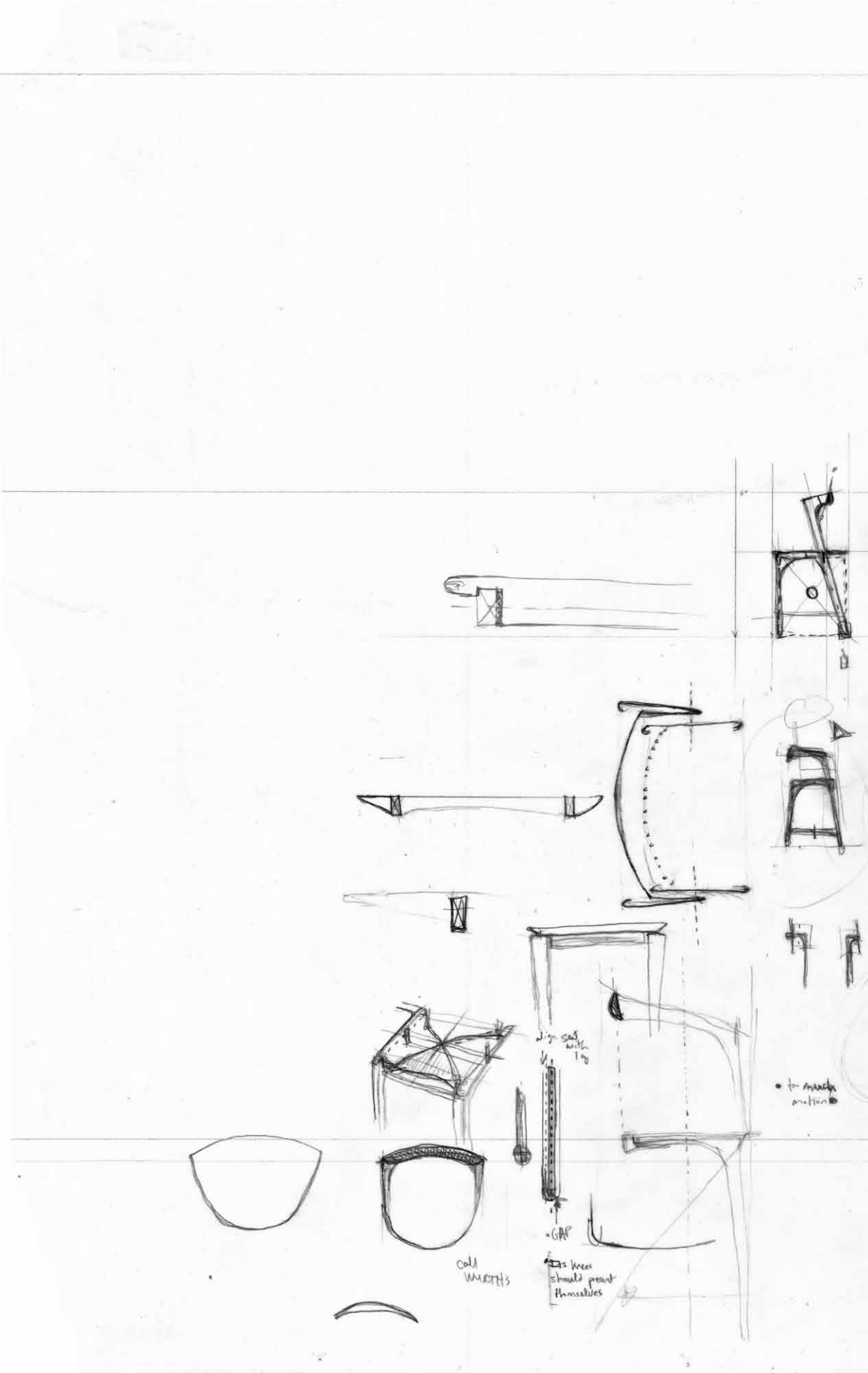



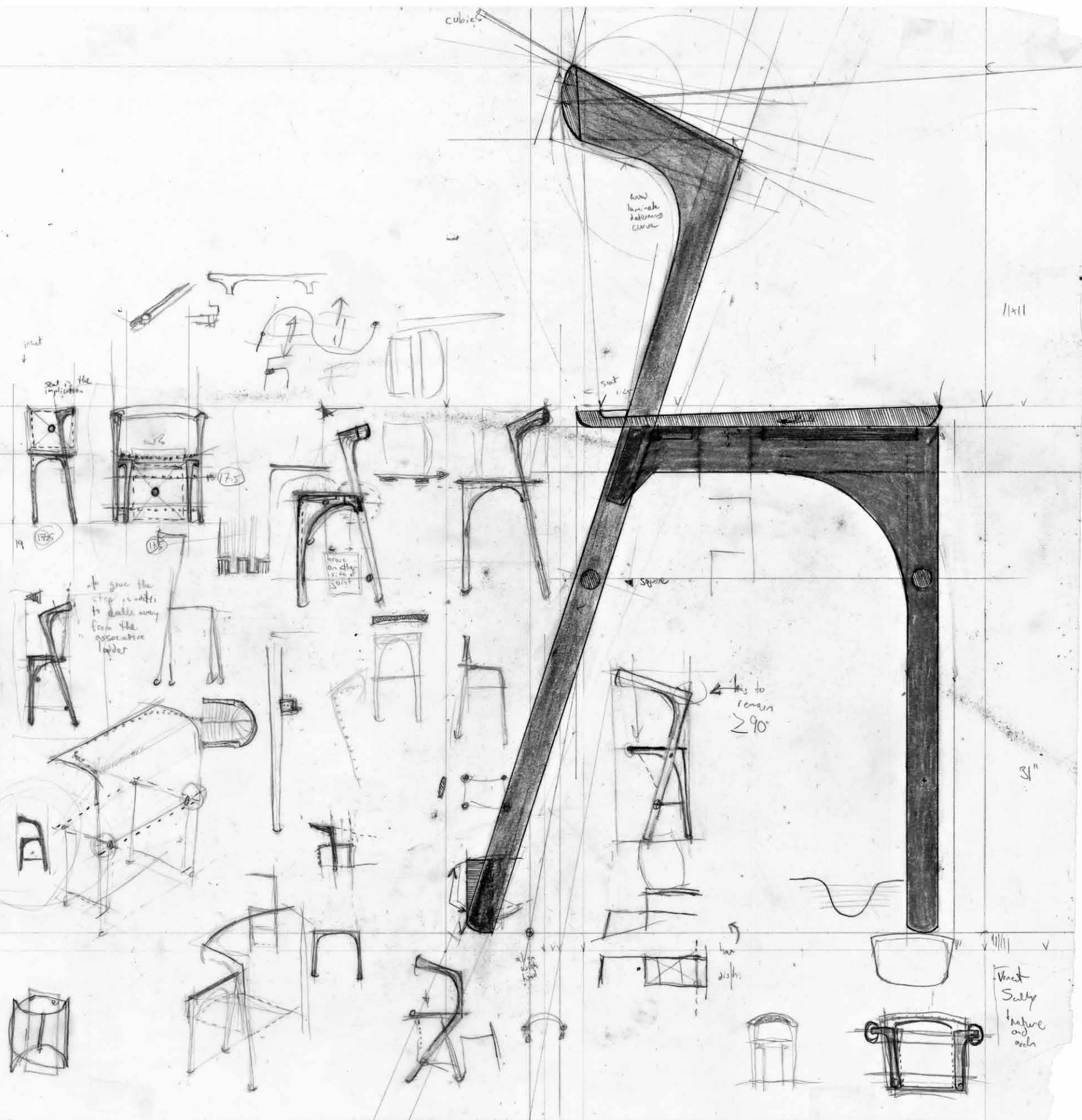

○ \_ An inverted figure, lead on trace paper

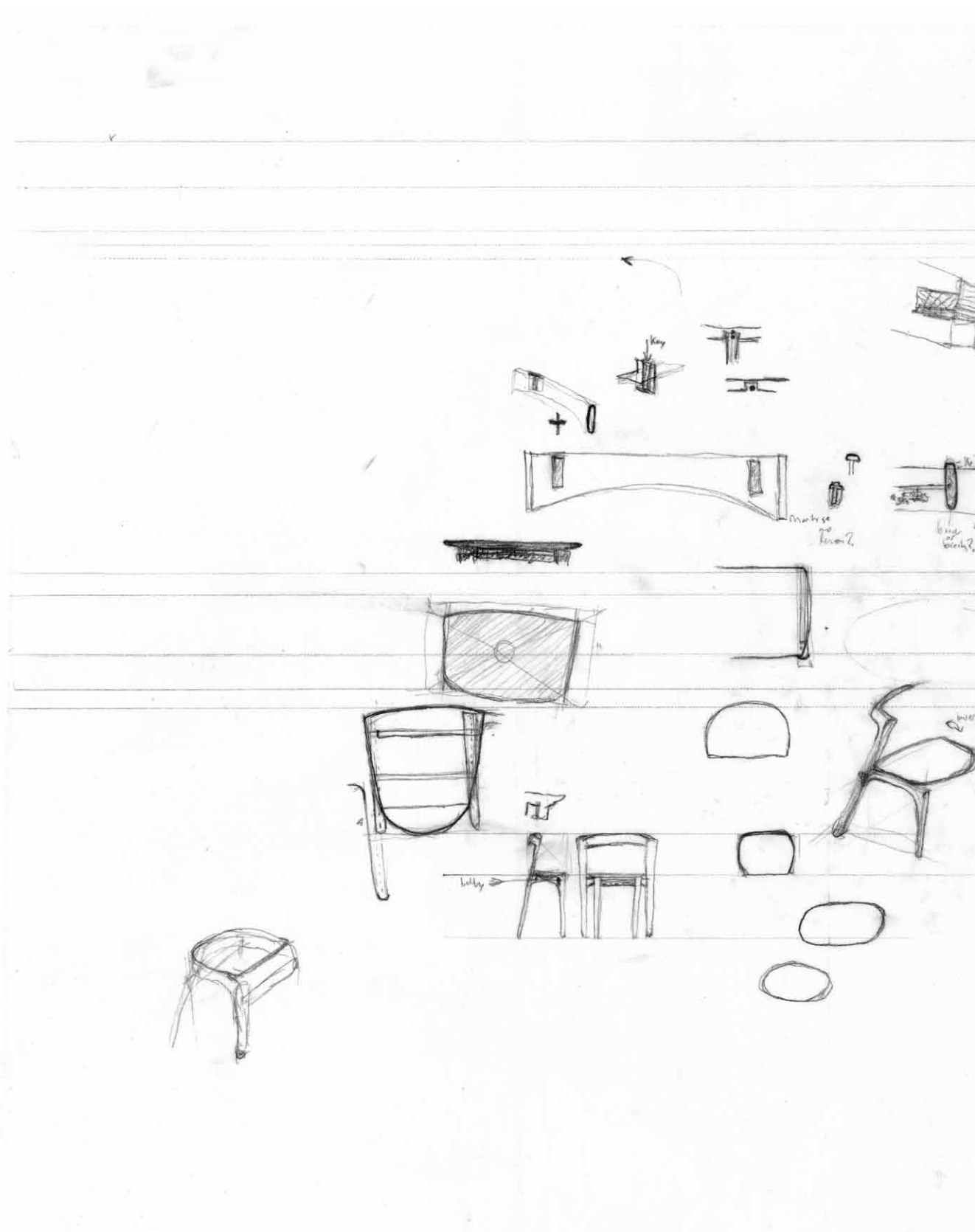

is the chair as dense? → more closed forms it  
means?

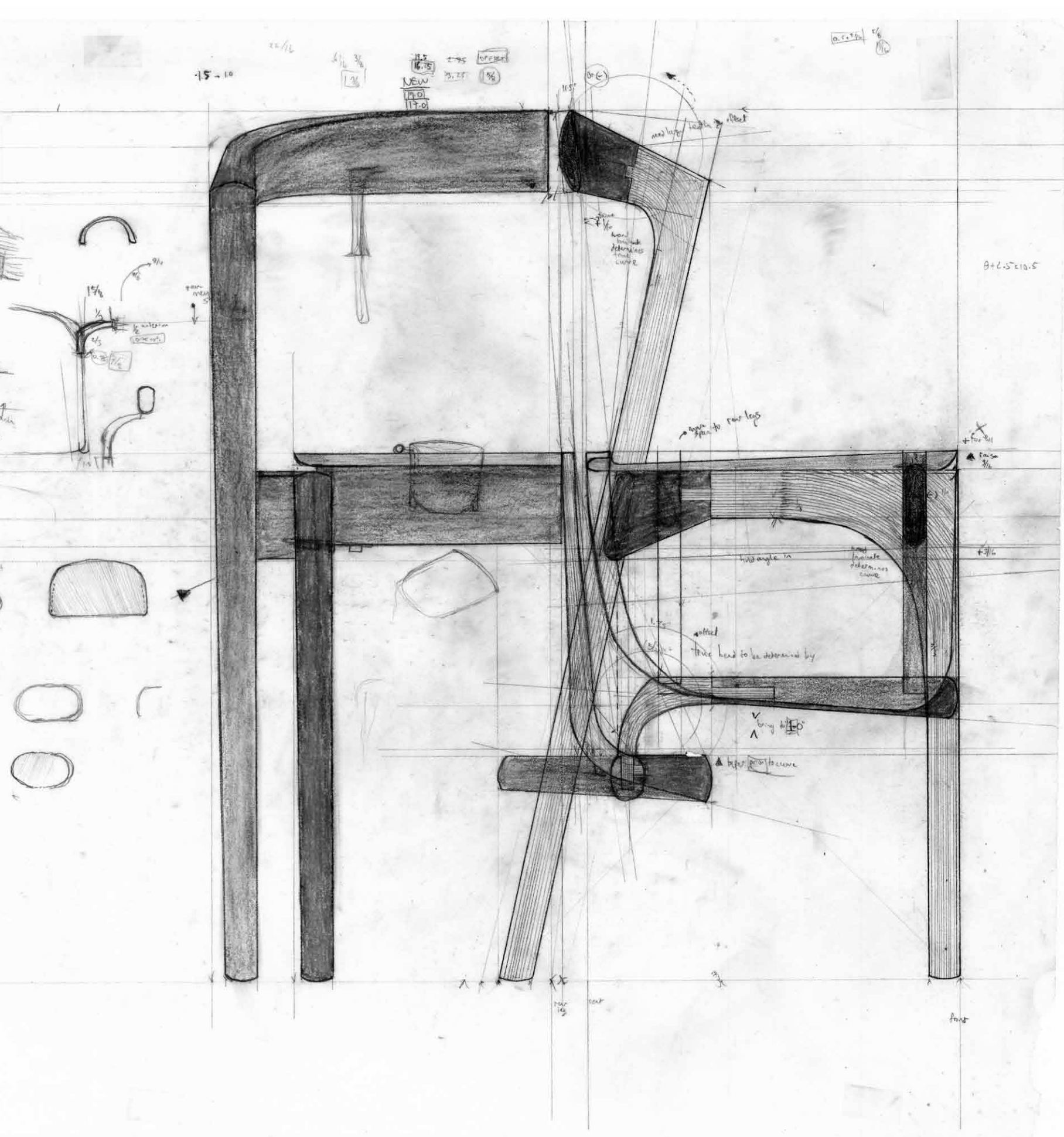

P \_ Raised struts, lead on trace paper



Q \_ Planed surface of rear knee, digital photo, credit / John Eskeland



R \_ Rough cut rear knee, digital photo, credit / Chris Taylor

To approach work, there is the flat surface.  
A machine serves the operation.  
If estranged, one will only labor.



S \_ Chiseling of a joint, digital photo, credit / Liam Smith

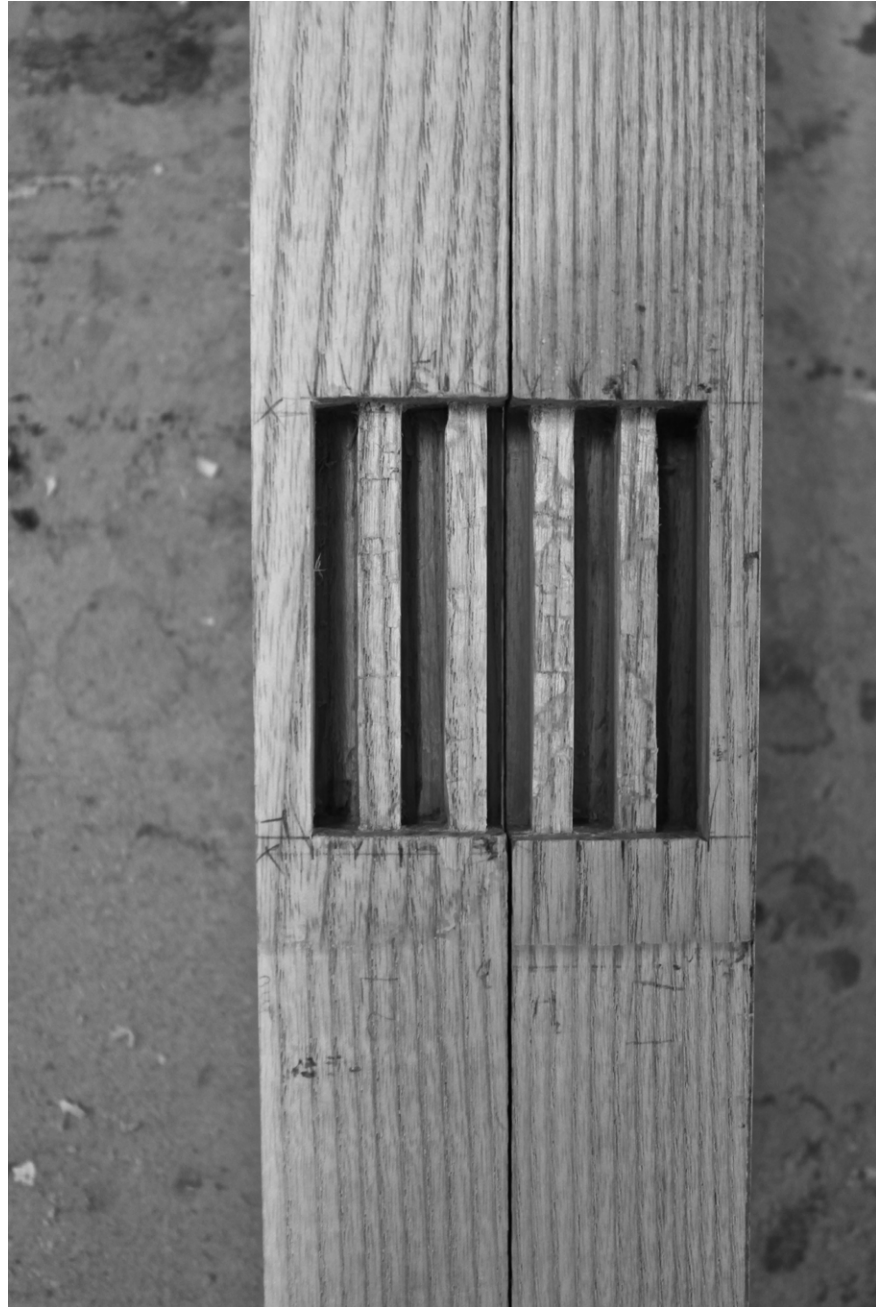

T \_ Joint for rear span, digital photo

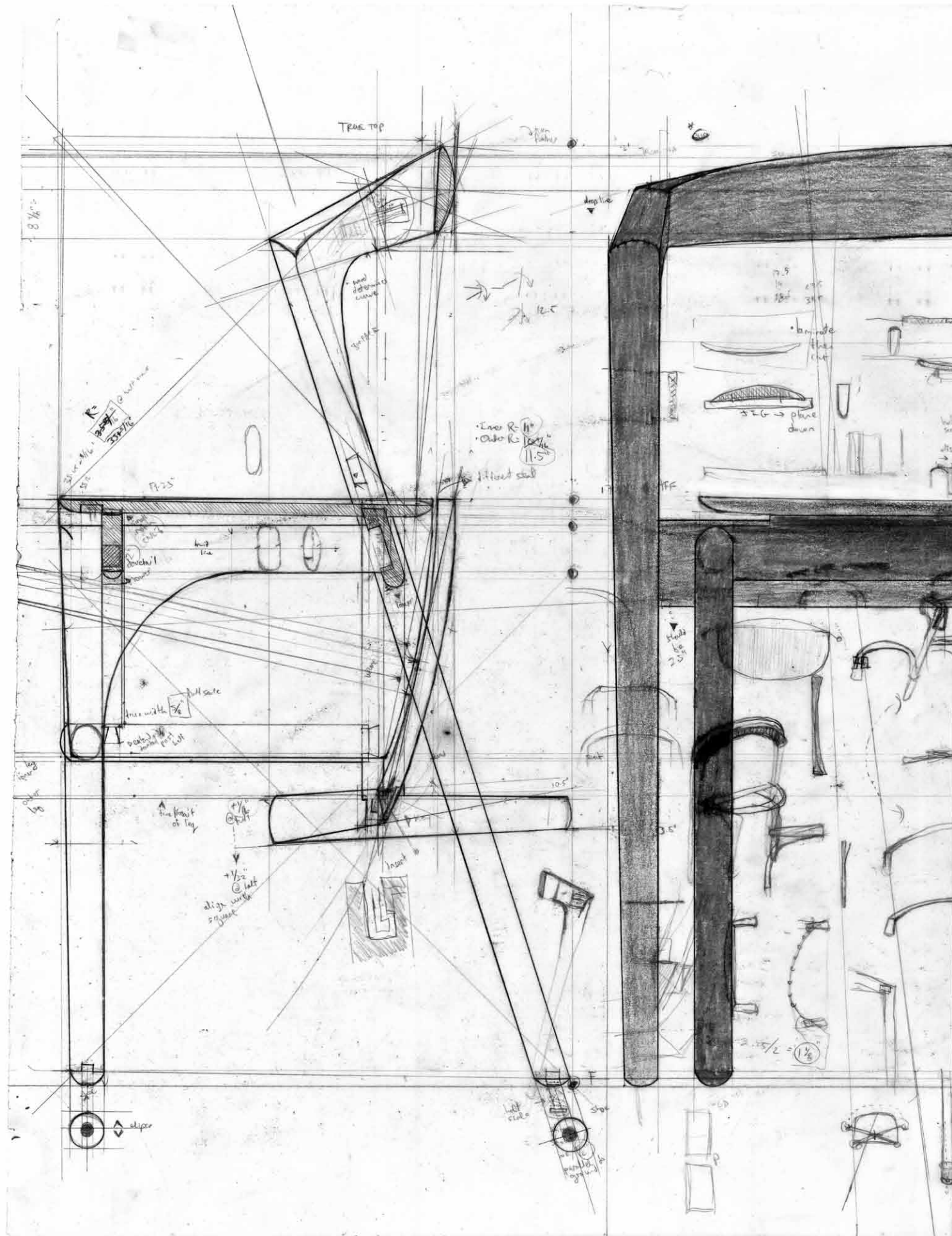



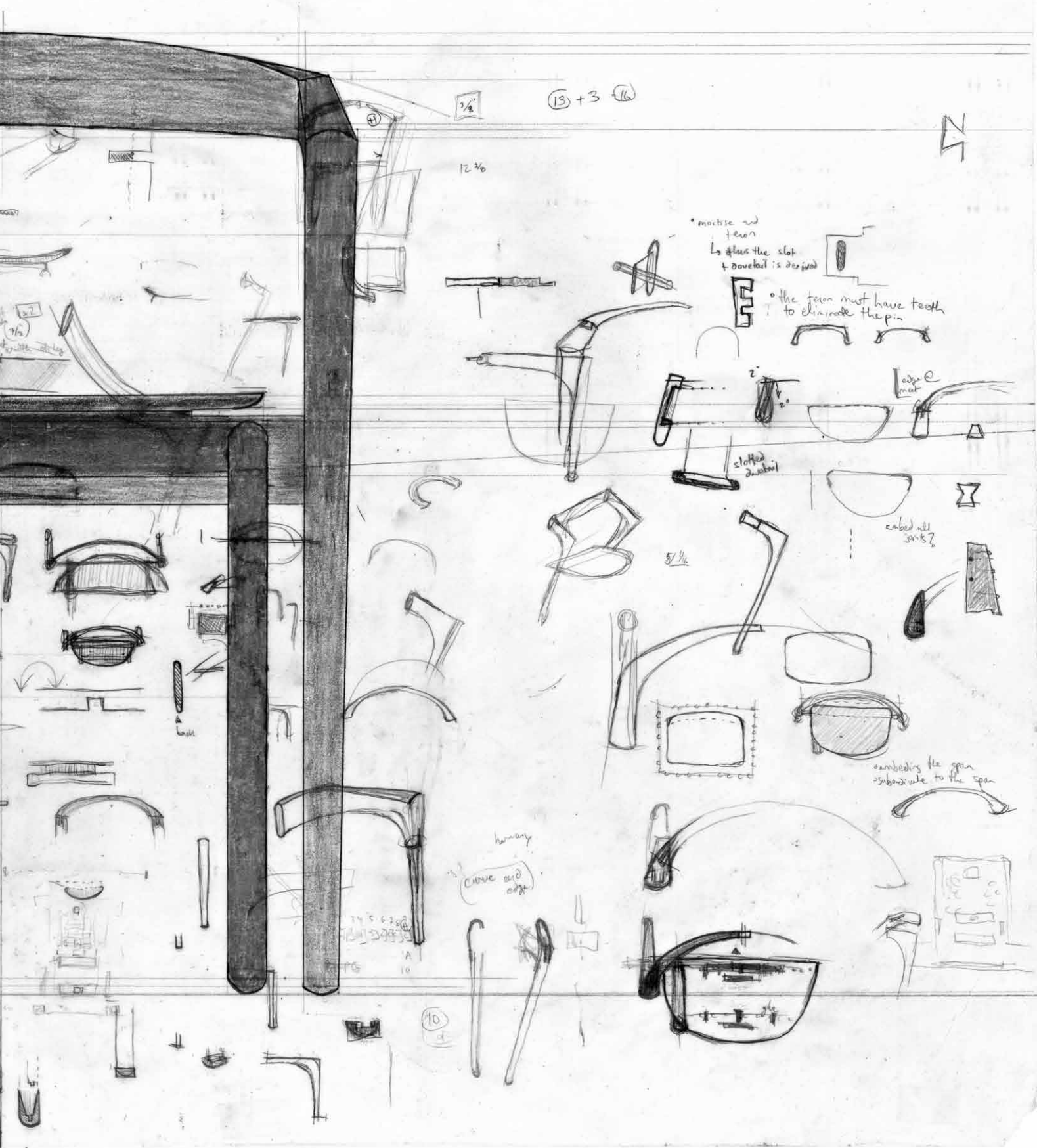

U\_A frame with a seat, lead on trace paper



V \_ Laminates embed the joint, digital photo



W \_ The cut of a curved back, digital photo, credit / Chris Taylor

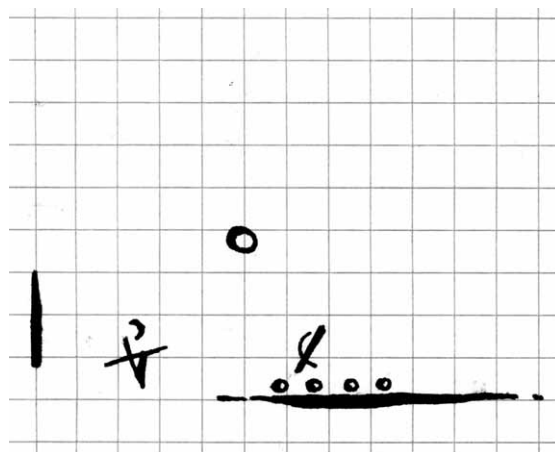

X\_ A thing in a world , ink on vellum paper

A memory of place is provocation.  
Although definitive, its presence moves.  
The thought is a part, this is constructive.  
The chair is made upon admittance.

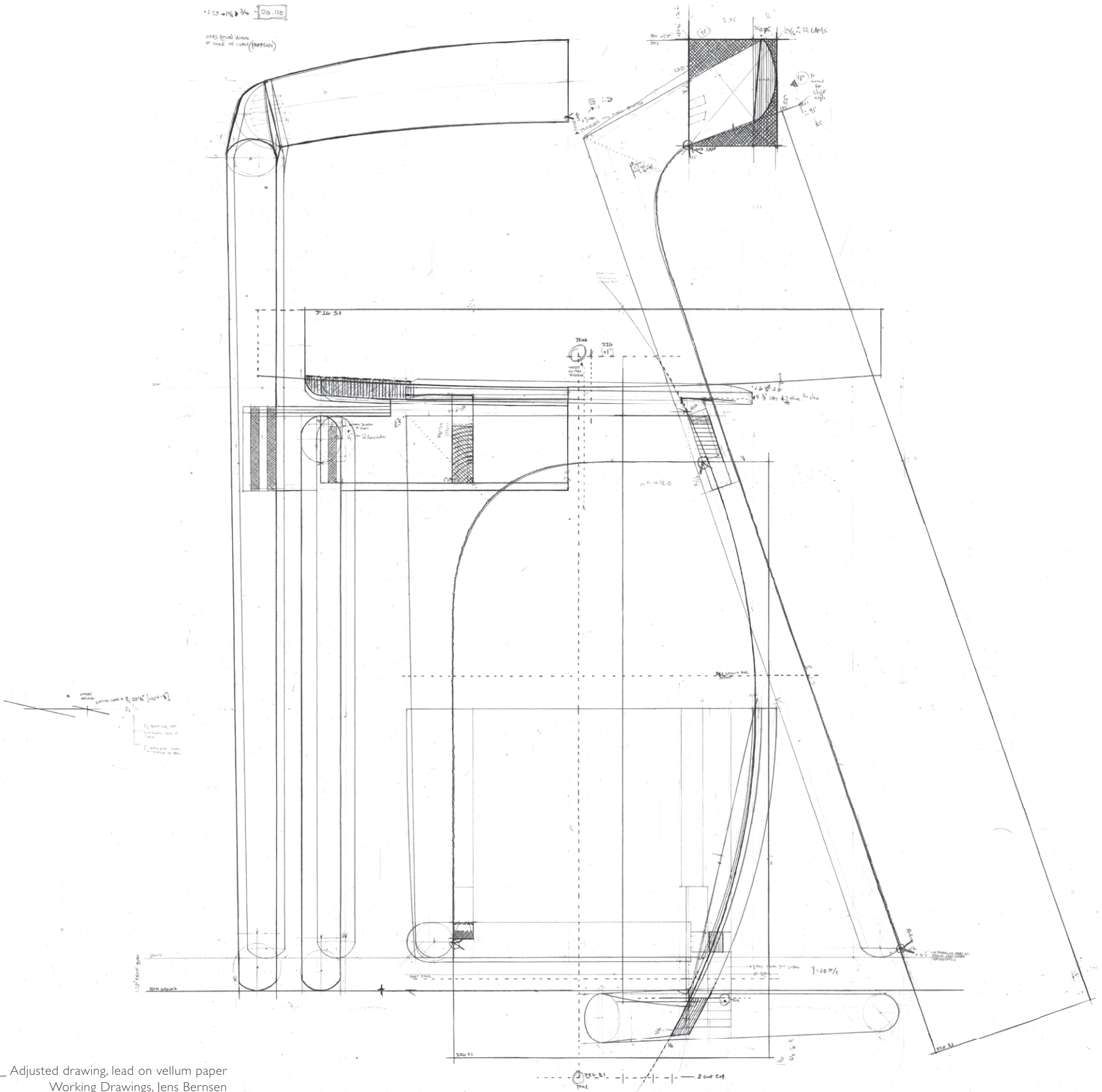

Y\_ Adjusted drawing, lead on vellum paper  
 Working Drawings, Jens Bernsen  
 Hans J Wegner, P. 61



Z \_ Shaping of front leg, digital photo, credit / Chris Taylor



AA \_ Sanding of rear leg, digital photo, credit / Tobias Leibing

The human world is always the product of man's amour mundi, a human artifice whose potential immortality is always subject to the mortality of those who build it and the natality of those who come to live in it; in this sense, in its need for beginners that it may be begun anew, the world is always a desert.

Hannah Arendt  
The Promise of Politics, P. 203





AB \_ Constructed Chair; digital photo

To exist in the world, the chair is measured.  
A patent calls an idea to be bound.  
Yet, parables continue to move.

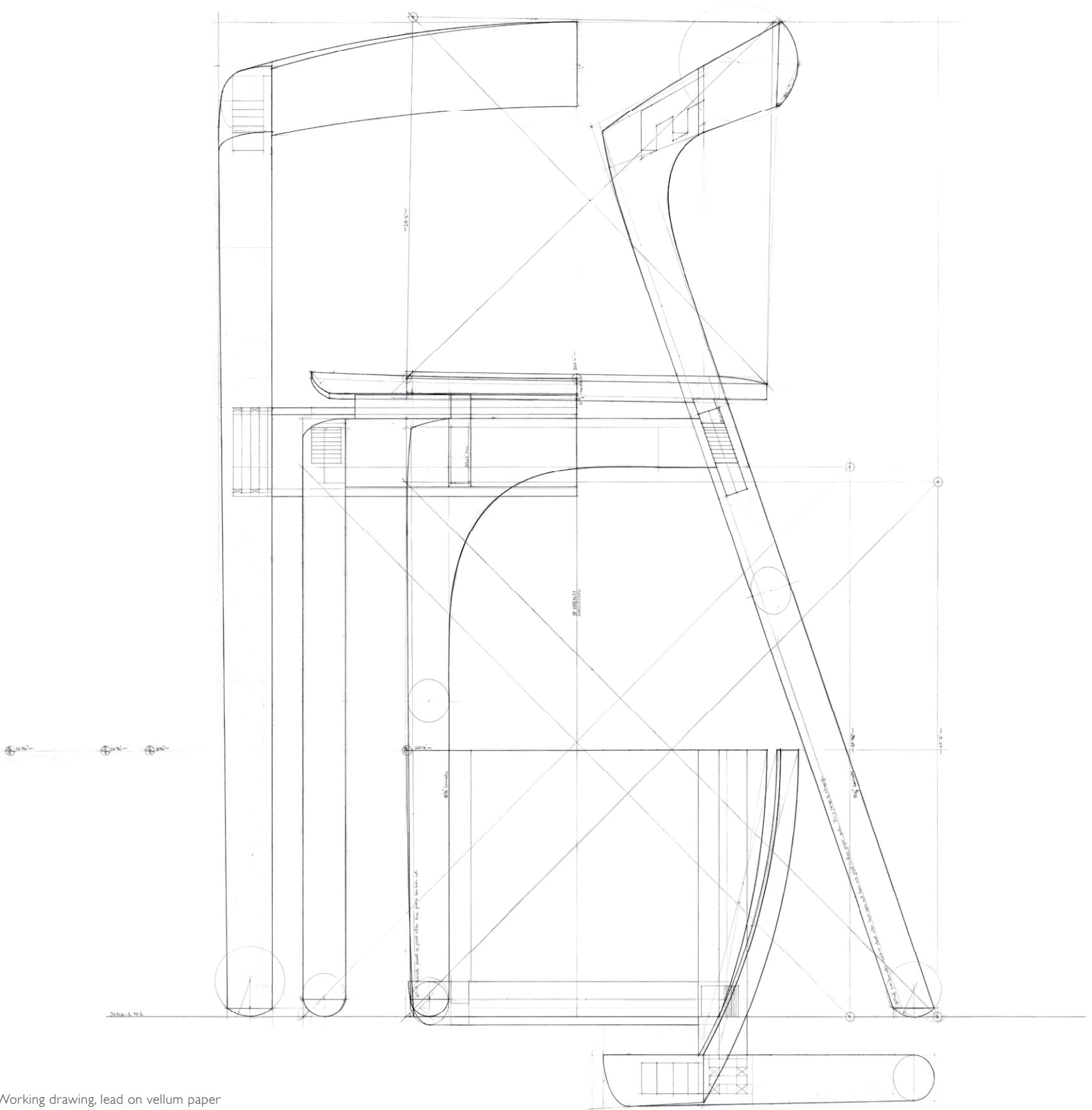

AC \_ Working drawing, lead on vellum paper  
Working Drawings, Jens Bernsen  
Hans J Wegner, P. 61



AD \_ A placed chair / face, digital photo

We are placed between earth and sky.  
The light here reveals a ground; so a chair is built.  
The seat is offered to a man who stands.



AE \_ A placed chair / back, digital photo

My family and friends continuously supported  
me in my studies. I am humbled.  
My professors acted with patience to provoke  
valuable critique. I am indebted.  
Mark, John, and Chris taught me to work with  
wood. I thank with each chair.

### List of Figures

- A \_ White ash laminates, digital photo / III
- B \_ Croffead House window, digital photo / 02
- C \_ Figures of a chair, lead on trace paper / 04 - 05
- D \_ Cast chair projection, lead on trace paper / 06 - 07
- E \_ Initial cut layout, digital photo / 08
- F \_ Rough laminate cut, digital photo / 09
- G \_ Seat in a frame, lead on trace paper / 10 - 11
- H \_ Lowered struts, lead on trace paper / 12 - 13
- I \_ Two positions, lead on trace paper / 14 - 15
- J \_ Wood cut for one chair, digital photo / 16
- K \_ Laminates bent for back, digital photo / 17
- L \_ Steamed rear leg, digital photo / 17
- M \_ Laminate prepped for glue, digital photo / 18
- N \_ Joint and chair models, digital photo / 19
- O \_ An inverted figure, lead on trace paper / 20 - 21
- P \_ Raised struts, lead on trace paper / 22 - 23
- Q \_ Planed surface of rear knee, digital photo / 24
- R \_ Rough cut rear knee, digital photo / 25
- S \_ Chiseling of a joint, digital photo / 26
- T \_ Span joint in rear legs , digital photo / 27
- U \_ A frame with a seat, lead on trace paper / 28 - 29
- V \_ Laminates embed the joint, digital photo / 30
- W \_ The cut of a curved back, digital photo / 31
- X \_ A thing in a world , ink on vellum paper / 32
- Y \_ Adjusted drawing, lead on vellum paper / 33
- Z \_ Shaping of front leg, digital photo / 34
- AA \_ Sanding of rear leg, digital photo / 35
- AB \_ Constructed chair, digital photo / 37
- AC \_ Working drawing, lead on vellum paper / 38
- AD \_ A placed chair / face, digital photo / 39
- AE \_ A placed chair / back, digital photo / 40

### Citation

Arendt, Hannah. The Promise of Politics. New York: Schocken Books, 2005.

Bernsen, Jens. Hans J Wegner. Kobenhavn: Danish Design Center, 2001.

Fjeld, Per Olaf. Sverre Fehn: The Thought of Construction. New York: Rizzoli, 1983.

### Additional Readings

Arendt, Hannah. The Human Condition. Chicago: Anchor Books, 1959.

Aureli, Pier V. The Possibility of an Absolute Architecture. Cambridge: The MIT Press, 2011.

Becksvoort, Christian. With the Grain. Fort Mitchell: Lost Art Press, 2013.

Breitschmid, Markus. Nietzsche's Denkraum. Zurich: Edition Didacta, 2006.

Candilis, G. Bent Wood Furniture. Stuttgart: Karl Kramer, 1980.

Corse, Sandra. Craft Objects, Aesthetic Contexts. New York: University Press of America, 2009.

McEwen, Indra K. Socrates' Ancestor: An Essay on Architectural Beginnings. Cambridge: The MIT Press, 1993.

Pallasmaa, Juhani, ed. Aalto: Alvar Aalto Furniture. Cambridge: The MIT Press, 1985.

Semper, Gottfried. The Four Elements of Architecture and Other Writings. New York: Cambridge University Press, 2010.

Stevens, Wallace. Harmonium. London: Faber and Faber Limited, 2001.

Zumthor, Peter. Thinking Architecture. Basel: Birkhauser, 2010.