

**BIOMECHANICAL ANALYSIS OF  
CARPAL FLEXION AND EXTENSION**

by

M. Susan Hallbeck

Dissertation submitted to the Faculty of the  
Virginia Polytechnic Institute and State University  
in partial fulfillment of the requirements for the degree of

**DOCTOR OF PHILOSOPHY**

in

Industrial Engineering and Operations Research

APPROVED:

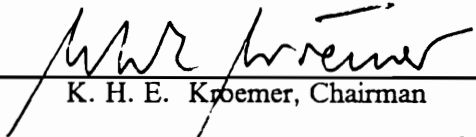
  
K. H. E. Kroemer, Chairman

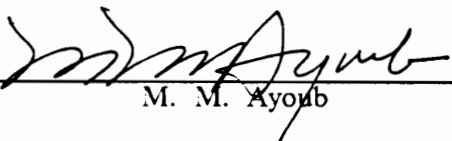
  
M. M. Ayoub

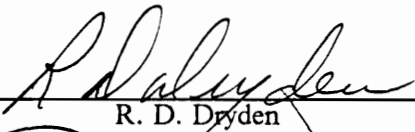
  
R. D. Dryden

  
H. L. Snyder

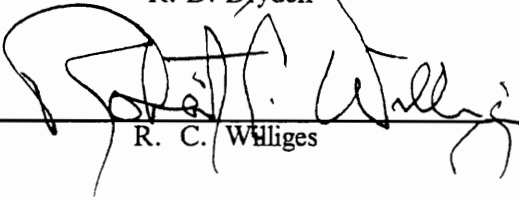
  
R. C. Williges

April, 1990

Blacksburg, Virginia

# BIOMECHANICAL ANALYSIS OF CARPAL FLEXION AND EXTENSION

by

M. Susan Hallbeck

K. H. E. Kroemer, Chairman

Industrial Engineering and Operations Research

(Abstract)

An experiment was performed to evaluate the relations between active range of motion (ROM) and upper limb anthropometric dimensions. Eight anthropometric dimensions, forearm length, distal and proximal forearm circumferences, wrist breadth, wrist thickness, wrist circumference, hand breadth, and hand length in combination with gender, wrist position, and direction of motion or exertion were evaluated to determine their effects on instant center of rotation (ICOR) and the magnitude of force exertion. The knowledge gained from analysis of the study data will be the first step in the formulation of a biomechanical model of wrist flexion and extension. Such a model would predict forces and torques at specific wrist postures and be employed to reduce cumulative trauma disorders of the wrist.

Sixty right-hand dominant subjects (30 male, 30 female) between 20 and 30 years of age all reporting no prior wrist injury and good to excellent overall physical condition, were employed in this study.

The upper limb anthropometric dimensions and ROM were measured and recorded for each subject. The anthropometric dimensions were compared to tabulated data. The measured active ROM values were compared with values in the literature. Correlation coefficients between pairs of anthropometric variables (by gender) were calculated. The mean active ROM measures, 164.0 deg for females and 151.8 deg for males, were significantly different ( $Z = 2.193$ ,  $p = 0.014$ ).

The relationships between the anthropometric variables and active ROM were analyzed by three methods: correlation between ROM and each anthropometric dimension, prediction (regression) equations, and analysis of variance (ANOVA). No correlation coefficient between ROM and any anthropometric dimension was greater than 0.7. No prediction equation, based upon linear and quadratic combinations of anthropometric dimensions variables, was above the threshold of acceptability ( $R^2 \geq 0.5$ ). The results of the ANOVA showed a significant effect for gender.

The ICOR had been hypothesized to be either in the head or neck of the capitate. The Method of Reuleaux was employed to locate the ICOR points for flexion and extension (over the ROM) of the wrist with three load conditions, i.e., no-load, palmar resistance, and dorsal resistance. Analysis of the data, using ANOVA, showed that wrist position was the only significant variable. Thus, in future wrist models, the assumption cannot be made that the wrist is a pin-centered joint for flexion and extension.

The static maximal voluntary contractile forces that can be generated by recruiting only the six wrist-dedicated muscles in various wrist positions were measured. There was a significant gender difference for the mean flexion force ( $Z = 4.00$ ,  $p = 0.0001$ ) and for the mean extension force ( $Z = 4.58$ ,  $p = 0.0001$ ). Females averaged 76.3 percent of the mean male flexion force and 72.4 percent for extension.

The force data, categorized by gender, were then analyzed using three methods: correlation of variable pairs, regression equations, and ANOVA. None of the eight anthropometric dimensions and ROM was correlated with flexion or with extension force at an acceptable level. The prediction equations, linear and quadratic combinations of all possible subsets of anthropometric dimension values, ROM, and wrist position did not meet the minimum acceptable level of  $R^2 \geq 0.5$ . The ANOVA procedure showed gender, wrist position, direction of force exertion, and the wrist position interaction with direction to have significant effects upon maximal force exertion.

## ACKNOWLEDGEMENTS

I would like to thank Drs. K.H.E. Kroemer, M.M. Ayoub, R.D. Dryden, H.L. Snyder, and R.C. Williges for serving on my committee.

The Industrial Engineering shop personnel, in particular Keith Wright, Randy Waldren, and Bart Moore, helped complete this dissertation by building and refining my instrumentation, and wiring it into the existing hardware available in the Industrial Ergonomics Laboratory. I wish to thank them for all their technical assistance.

I would like to thank my parents for supporting me, both financially and emotionally, through my schooling. This should, by rights, be a degree to share with the entire family.

A special note of thanks goes to my colleagues, who shared their knowledge, time, and humor to aid me.

## TABLE OF CONTENTS

REVIEW OF LITERATURE .....	1
Introduction .....	1
Range of motion .....	2
Center of rotation .....	2
Forces .....	3
Carpal Anatomy .....	4
Muscles and tendons .....	6
Kinematic Linkage Models of the Wrist .....	9
Dual articular concept .....	9
Intercalated link concept .....	13
Screw-vice of clamp concept .....	16
Columnar concept .....	17
Functional unit .....	17
Summary .....	18
Range of Motion .....	20
Center of Rotation .....	22
Force Generation .....	26
Maximal voluntary contraction .....	26
Factors affecting force generation .....	27
Measured flexion and extension forces .....	28
METHOD .....	30
Apparatus .....	30
Subjects .....	38
Procedure .....	38
Range of motion .....	38
Instant center of rotation and force measurements .....	39

Experimental Design .....	41
Range of motion .....	41
Instant center of rotation .....	41
Force .....	44
Analysis .....	44
Range of motion .....	44
Instant center of rotation .....	45
Force .....	45
RESULTS .....	46
Comparison of the Subject Pool to Population Norms .....	46
Correlations between Measured Variables .....	50
Range of Motion .....	51
Center of Rotation .....	57
Force Generation .....	62
DISCUSSION AND CONCLUSIONS .....	73
Anthropometric Dimensions .....	73
Range of Motion .....	73
Center of Rotation .....	74
Force Generation .....	76
Recommendations .....	77
REFERENCES .....	79
APPENDIX A. CARPAL ANATOMY .....	89
Carpal Bones .....	89
Scaphoid .....	89
Lunate .....	89
Triquetrum .....	90
Pisiform .....	90
Trapezium .....	91

Trapezoid . . . . .	92
Capitate . . . . .	92
Hamate . . . . .	93
Ligaments . . . . .	94
Muscles and Tendons . . . . .	96
Extensor carpi radialis longus . . . . .	99
Extensor carpi radialis brevis . . . . .	99
Extensor carpi ulnaris . . . . .	99
Flexor carpi ulnaris . . . . .	99
Flexor carpi radialis . . . . .	99
Palmaris longus . . . . .	100
Digital muscles . . . . .	100
Carpal Tendons . . . . .	102
Extensor tendons . . . . .	102
Flexor tendons and the flexor retinaculum . . . . .	102
Tendon sheaths . . . . .	102
Single Carpal Bone Position during Flexion and Extension . . . . .	103
APPENDIX B. COMPUTER PROGRAM FOR METABYTE A/D CONVERTER	106
APPENDIX C. CONSENT FORM . . . . .	111
Attachment to Consent Form . . . . .	112
Physical Fitness Questionnaire . . . . .	114
Instructions for Wrist Study . . . . .	115
Anthropometric measurements . . . . .	115
Range of motion and instant center of rotation . . . . .	115
Force measurements . . . . .	115
APPENDIX D. COMPUTER PROGRAM FOR CENTER OF ROTATION . . . . .	117
APPENDIX E. ANTHROPOMETRIC DATA . . . . .	119
APPENDIX F. SIMPLE EFFECT F-TESTS BY WRIST POSITION . . . . .	121

## LIST OF FIGURES

Figure 1. Carpal bones . . . . .	5
Figure 2. Wrist complex . . . . .	10
Figure 3. Wrist as a link mechanism . . . . .	14
Figure 4. Central dorsal zone . . . . .	19
Figure 5. Extreme wrist flexion and extension . . . . .	21
Figure 6. Center of rotation of the wrist . . . . .	25
Figure 7. Forearm securing box . . . . .	31
Figure 8. Handle . . . . .	32
Figure 9. Schematic of the ICOR measurement apparatus . . . . .	34
Figure 10. Photograph of the ICOR measurement apparatus . . . . .	35
Figure 11. Schematic of the force measurement apparatus . . . . .	36
Figure 12. Photograph of the force measurement apparatus . . . . .	37
Figure 13. Side-view of the force measurement apparatus . . . . .	42
Figure 14. Top-view of the force measurement apparatus . . . . .	43
Figure 15. Flexion force versus wrist position . . . . .	71
Figure 16. Extension force versus wrist position . . . . .	72
Figure 17. Wrist extensor muscles . . . . .	97
Figure 18. Wrist flexor muscles . . . . .	98



## LIST OF TABLES

Table 1. Contribution of the Dual Articulation to ROM . . . . .	12
Table 2. Active ROM . . . . .	23
Table 3. Static Wrist Torques . . . . .	29
Table 4. Male Anthropometric Dimensions . . . . .	47
Table 5. Female Anthropometric Dimensions . . . . .	48
Table 6. Results of Test of Differences between Means and Homogeneity of Variance for Anthropometric Dimensions . . . . .	49
Table 7. Product-Moment Correlations between Variables (Male) . . . . .	52
Table 8. Product-Moment Correlations between Variables (Female) . . . . .	53
Table 9. Total ROM, Critical Ratio, and Associated Probabilities . . . . .	55
Table 10. Best ROM Regression Models . . . . .	56
Table 11. ROM ANOVA Summary Table . . . . .	58
Table 12. ICOR ANOVA Summary Table . . . . .	60
Table 13. ICOR Least Significant Difference T-Test . . . . .	61
Table 14. Force Comparisons using Critical Ratio Test . . . . .	63
Table 15. Best Force Regression Models . . . . .	64
Table 16. Force ANOVA Summary Table . . . . .	66
Table 17. Force Least Significant Difference T-Test . . . . .	67
Table 18. Mean Flexion and Extension Forces and Simple Effect F-Test Probabilities by Wrist Position . . . . .	69
Table 19. Average Force for each Wrist Position . . . . .	70
Table 20. Carpi Muscles . . . . .	101
Table 21. Female Anthropometric Dimensions . . . . .	119
Table 22. Male Anthropometric Dimensions . . . . .	120
Table 23. 90-deg Flexion ANOVA Summary Table . . . . .	121
Table 24. 75-deg Flexion ANOVA Summary Table . . . . .	122
Table 25. 60-deg Flexion ANOVA Summary Table . . . . .	123

Table 26. 45-deg Flexion ANOVA Summary Table . . . . .	124
Table 27. 30-deg Flexion ANOVA Summary Table . . . . .	125
Table 28. 15-deg Flexion ANOVA Summary Table . . . . .	126
Table 29. 0-deg (Neutral) Flexion ANOVA Summary Table . . . . .	127
Table 30. 15-deg Extension ANOVA Summary Table . . . . .	128
Table 31. 30-deg Extension ANOVA Summary Table . . . . .	129
Table 32. 45-deg Extension ANOVA Summary Table . . . . .	130
Table 33. 60-deg Extension ANOVA Summary Table . . . . .	131
Table 34. 75-deg Extension ANOVA Summary Table . . . . .	132
Table 35. 90-deg Extension ANOVA Summary Table . . . . .	133

## REVIEW OF LITERATURE

### Introduction

Functional injury to the upper extremity is fairly common and accounts for about 10 percent of all compensation paid in the United States for disabling work-related injuries (Morrey, An, and Chao, 1985). The National Safety Council (as cited by Armstrong, 1982) estimates that 21 percent of all compensation is paid for upper extremity injuries. A model of the wrist (which would predict the forces and postures that may induce functional injury) could save both human anguish and large amounts of compensation. Armstrong and Chaffin (1978) began a model of extrinsic finger flexors that cross the wrist based upon Landsmeer's (1960) work on the fingers. Their model calculates the bowstring force of the extrinsic flexor tendons upon the flexor retinaculum and was designed to aid in the prediction of cumulative trauma disorders, with an emphasis on carpal tunnel syndrome (Armstrong and Chaffin, 1978).

The upper limb is a framework of bones and ligaments powered and stabilized by agonist and antagonist synergistic muscles. Therefore, the motion and functional capabilities of the bones, ligaments, and muscles must be studied and quantified to provide the basis for a model of the upper limb.

The digits have been modeled by several authors both in two dimensions (Berme, Paul, and Purves, 1977; Chao and An, 1978; Cooney and Chao, 1977; Hirsch, Page, Miller, Dumbleton, and Miller, 1974; Landsmeer, 1961; Spoor and Landsmeer, 1976) and in three dimensions (An, Chao, Cooney, and Linscheid, 1979; Chao, Opgrande, and Axmear, 1976; Toft and Berme, 1980). These models of prehension are indeterminate and predict internal forces only, so it has not been possible to validate them in vivo.

The elbow has also been modeled in flexion and extension by several researchers (An, Hui, Morrey, Linscheid, and Chao, 1981; An, Kaufman, and Chao, 1987; An, Morrey, and Chao, 1985; Crowninshield, 1978; Morrey et al., 1985; Yeo, 1976). They modeled it as a hinge joint powered by three major muscles.

To connect the models of the hand (digits) and forearm (elbow) joints, the wrist must be modeled. The wrist has two basic motions, flexion-extension and (ulnar-radial) deviation. The combination of these motions is called circumduction (Kauer, 1986). A complete model of the wrist includes motions around these two axes, as well as pronation and supination (Fisk, 1981).

The basic literature on carpal anatomy has been summarized (Appendix A). The literature on upper limb musculature, kinematic wrist linkage, and their possible effect(s) on range of motion (ROM), instant center of rotation (ICOR), and force generation were examined. The ROM, ICOR, and active force exertion for carpal flexion and extension were then studied and quantified for a subject population.

Range of motion. The active individual ROM is a function of many variables. Some of these mentioned in the literature are age, gender, injury, and upper limb anthropometric dimensions (Brumfield, Nickel, and Nickel, 1966; Dempster, 1960; Staff, 1983, as cited by Kroemer, Kroemer, and Kroemer-Elbert, 1986; Woodson, 1981). Statistical correlations between ROM and these variables have not yet been experimentally determined.

Center of rotation. The current kinematic (biomechanical) models of the wrist are either single bone or single joint models, representing the positions of the bones with respect to one another. There are several different hypotheses on the nature of the carpal link. None has been validated, but the most widely accepted is the dual articular system. The dual articulation is comprised of the radiocarpal (RC) and midcarpal (MC) joints which are independent in action, yet both contribute to the total range of motion (ROM) of the wrist in flexion and extension (Kauer and De Lange, 1987; Weber, 1984, 1988; Wright, 1935). There is no consensus in the literature on the location of the center of rotation (COR) for the combination of movements achieved in these articulations; however, the COR has basically been located in two positions, either the head or the neck of the capitate. Researchers (Bunnell, 1948; Dempster, 1955, 1960; Fisk, 1981, 1984; Gilford et al., 1943; Linscheid, 1986; MacConaill, 1941; Volz, 1976;

Youm et al., 1978; Youm and Yoon, 1979) disagree on whether the COR consists of a single point or is actually a series of ICOR points over the ROM.

The COR has typically been determined in three positions, in extreme flexion, neutral position, and extreme extension. Four authors have hypothesized that the COR was a single point (Fisk, 1981, 1984; Linscheid, 1986; MacConaill, 1941; Volz, 1976), while others stated that the ICOR points formed a small grouping (Andrews and Youm, 1979; McMurtry et al., 1978).

The Method of Reuleaux (1876, as cited by Dempster, 1955, 1960; Frankel and Nordin, 1980) has been routinely employed to determine the ICOR points of the knee and jaw (Frankel and Nordin, 1980). Only Dempster (1955, 1960) used this method to analyze the flexion and extension of the wrist. He found that the ICOR points formed a small (1.9 cm) diameter circle within the lunatocapitate joint. The accuracy of this method as applied to wrist-joint COR determination is unknown, as is the pattern that the ICOR points follow over the entire ROM.

All studies on the COR found in the literature were performed on wrists where the only load was gravitational pull on the masses of the hand, wrist, and forearm. This is called a "no-load" condition. It is not known if external forces acting on the hand or forearm and transmitted through the wrist change the ICOR location(s). Individual differences in these experimental load conditions may also be a function of bone geometry.

Thus, before biomechanical models of the wrist can be formulated the ICOR locations must be analyzed. A single point COR would permit simplification of the wrist joints into a hinge joint for flexion and extension.

Forces. Forces that can be generated by the upper limb have been measured by orthopedic surgeons, ergonomists, and occupational and physical therapists. They measured peak prehensile (pinch) and grip forces which are widely accepted as indicators (predictors) of upper limb strength (Fess and Moran, 1981). Digit, hand, wrist, and elbow position influence peak pinch and grip strengths (Anderson, 1965;

Hazelton, Smidt, Flatt, and Stephens, 1975; Kraft and Detels, 1972; Mathiowetz, Rennells, and Donahoe, 1985; Pryce, 1980; Skovly, 1967; Woody and Mathiowetz, 1988). Forces acting between the forearm and hand are generated by exertions of agonistic and antagonistic muscle groups within both the hand (intrinsic) and in the forearm (extrinsic) and by wrist dedicated (carpi) muscles.

Gender has been found to affect the amount of force generated (An, Askew, and Chao, 1986; Chaffin and Andersson, 1984; Roebuck, Kroemer, and Thomson, 1975; Sanders and McCormick, 1986). Flexion force generation is reported to be greater than that for extension (Brand, 1985; Norkin and Levangie, 1983; Thompson, 1981).

The only quantitative force measurement of wrist flexion and extension was done isometrically by An et al. (1986). They did not describe the position of the wrist or elbow. The position of the hand and digits was a power prehension around a cylinder which measured the exertion. Thus, the intrinsic and extrinsic digital muscles, in addition to the wrist-dedicated muscles, were innervated and contracted.

Forces that can be generated by the wrist-dedicated muscles alone have not been studied. Although the "strength" of each muscle/tendon unit has been studied in cadavers, the synergistic combinations of contraction which constitute the controlling mechanism of wrist movement cannot be analyzed using cadaver data. To understand the contribution of the wrist-dedicated muscles to exertions involving the upper extremity, the forces that the six wrist-dedicated muscles can exert at standardized wrist positions must be measured and analyzed.

#### Carpal Anatomy

The human carpus is the portion of the upper extremity that extends from the distal radius to the metacarpal shafts (Weber, 1988). This area is commonly called the wrist. The carpus consists of the distal articular epiphysis of the radius, the distal radioulnar joint (DRUJ), and eight carpal bones -- lunate, triquetrum, pisiform, scaphoid, trapezium, trapezoid, capitate, and hamate. These bones are shown in Figure 1.

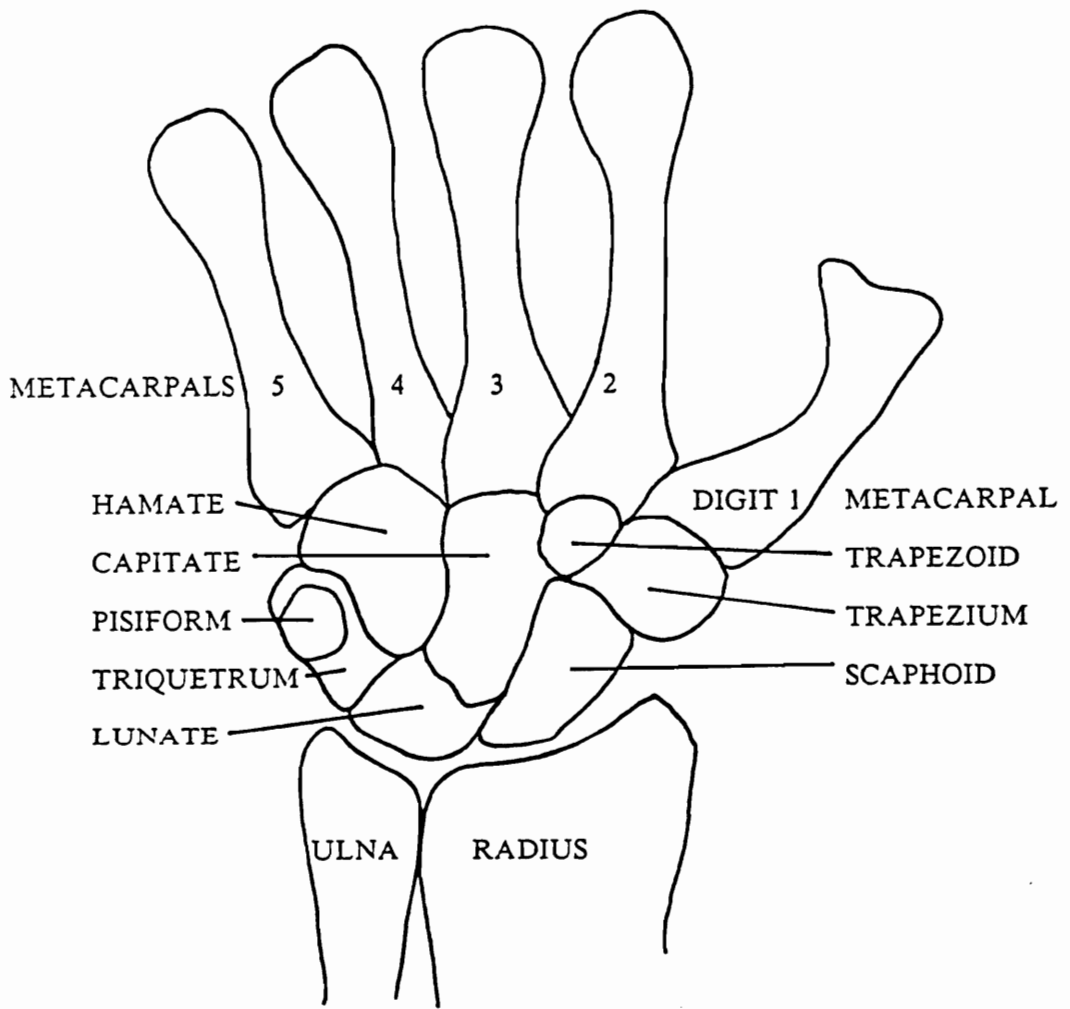

Figure 1. *Carpal bones (palmar view of the right hand) (adapted from Norkin and Levangie, 1983).*

From an anatomical viewpoint, the wrist represents a joint complex of rather remarkable flexibility and stability considering it is composed of eight small articulating bones which, when examined separately, possess no significant mechanical stability between pairs. Stability of the wrist's multifaceted joints is achieved predominantly by the dorsal and volar ligamentous and capsular structures; additional stability is also offered by the close proximity of the wrist flexors and extensors to the carpus (Volz, 1976).

The wrist is a complex articulation that plays an integral part in hand function. An appreciation of the role requires a thorough knowledge of the anatomy, mechanics, forces, ligamentous constraints, and load-bearing characteristics of the wrist joint (Linscheid, 1986). In wrist (carpal) movements, normal carpal mechanics are dependent on a complex interplay between the arrangement of carpal ligaments and carpal bone geometry (Viegas, Tencer, Cantrell, Chang, Clegg, Hicks, O'Meara, and Williamson, 1987). Mobility of the distal radioulnar joint and the wrist (radiocarpal and midcarpal) joints permits the hand to be placed in a great variety of positions. The joint surfaces and the muscles acting over the joints are arranged such that stability can be provided in all functional positions of the wrist and hand (Flatt, 1961; Linscheid, 1986). Functionally, the carpal unit transmits forces, generated or applied, through the hand to the forearm (Tsumura, Himeno, An, Cooney, and Chao, 1987; Weber, 1984, 1988).

Muscles and tendons. For muscle equilibrium within the hand and wrist the forces of extension must balance those of flexion and forces of abduction those of adduction. The individual flexion, extension, abduction, and adduction forces comprise important information to aid understanding of the balance within the wrist. For the use of the hand in work situations, it is important to know the effective output of the hand or wrist (Ketchum, Brand, Thompson, and Pocock, 1978).

Each individual has many internal variables which characterize every muscle. Some of these are muscle fiber length, fiber type, number of muscle bundles, recruitment (innervation) pattern, contractile length, and location of the muscle (Astrand and



Rodahl, 1986; Brand, 1985; Stegemann, 1981). The size of the muscle belly or physiological cross-sectional area (PCSA) of the muscle is proportional to the force it can exert (Fick, 1850; Fick, 1911; Weber, 1836, all as cited by Ketchum et al., 1978).

Training and motoneuron efficiency, which may cause a variation of the composition of the muscle tissue and a variation in the number of muscle cells which may be engaged through a maximal exertion of the subject's willpower, may explain the fact that the effect PCSA of a muscle may not be a dependable measure of the absolute maximal strength (Astrand and Rodahl, 1986). However, it may be adequate for relative strength comparisons.

The muscles of the wrist and the extrinsics of the hand (digits) lie in the forearm and narrow into tendons that traverse the wrist to insert in the bony or ligamentous components of the hand. The tendons of the wrist and hand pass through bony and ligamentous guide systems and include those inserting into the carpus, metacarpals, and those mediating digital flexion and extension (Taylor and Schwarz, 1955). All of the muscles responsible for wrist movement pass over the carpus and insert into the bases of the metacarpals (Flatt, 1961). Anatomical position of each muscle varies among individuals, both in location and in the number of branches (heads). The digital and carpal muscle functions are discussed in more detail in Appendix A.

Stability of the wrist is provided by the carpal and digital extrinsic muscles passing over both the flexor and extensor surfaces (Flatt, 1961). For practical purposes, the internal forces supplied by the musculotendinous units crossing the wrist are important in that they act continuously on the carpal elements. External forces become important only when they exceed the constraint forces of the carpal ligaments or strength of the bones (Linscheid, 1986).

Static positioning of the hand and wrist requires balanced action of many synergistic muscle sets (Brand, 1985). Wrist position affects finger position (Pryce, 1980; Woody and Mathiowetz, 1988). Grip strength is greater in the extended wrist than in the flexed wrist, owing to increased length of the flexor tendons (Linscheid and Chao, 1973).

Because the extrinsic muscles to the digits cross the wrist, the wrist position adjusts the length-tension relationships of these tendons, thus contributing a mechanical transducer effect to the digits (Linscheid, 1986).

The muscles that control the wrist serve two functions in the hand. They provide the fine adjustment of the hand into its functioning position and once this position is achieved they stabilize the wrist to provide a stable working platform for the hand and digits (Hazelton et al., 1975). If wrist movement is considered in relation to digit movement, two independent actions are found to be possible. When the wrist-dedicated muscles stabilize the joint, the extrinsic and intrinsic digit muscles can alter the position of the digit(s). Conversely, when digit posture is stabilized, the wrist can be positioned over a large ROM (Flatt, 1961).

In the normal hand, strong flexion of the extrinsic digital flexors produces a synergistic contraction of the wrist extensors (Kaplan and Smith, 1984). The digital flexors and extensors contribute to the wrist action, particularly under loads. In such cases, the digital muscles develop reaction forces against the object held (or within the hand itself if the fist is clenched) and add their contractile forces to the wrist action (Taylor and Schwarz, 1955). This stabilizing antagonism is demonstrated in maximal exertions where nearly all forearm muscles contract to stabilize the wrist (Amis, Dowson, and Wright, 1979). Participation of the muscle sets is proportional to the loading applied (Amis et al., 1979). Muscles whose tendons merely cross the wrist (secondary wrist movers) on route to the digits cannot be relied upon for their wrist moving and stabilizing characteristics, since wrist function may at times conflict with their primary digit function(s) (Brand, 1985). This dual innervation may be bypassed when subjects are instructed to extend the wrist with maximal effort while their fingers are loose and flaccid (Ketchum et al., 1978).

The forearm complex has been optimized for strength in flexion, not extension. The hand contains more flexors than extensors, and they are more powerful (Thompson,

1981). When the physical capacity of the wrist muscles is assessed, the wrist flexors have more than twice the capacity of the extensors (Norkin and Levangie, 1983).

### Kinematic Linkage Models of the Wrist

The wrist joint allows the hand to combine dorsovolar flexion and radioulnar deviation. This combination of functions is made possible by a highly complex system of joints that involves simultaneous movement between the individual carpal bones, which are bound together by intrinsic and extrinsic ligaments. The stability of the wrist is ensured by ligaments, muscles (tendons), and by the geometry of the articulating carpal bones (de Lange, Huiskes, and Kauer, 1987).

Previous models of the wrist have been qualitative, describing either the movement of each carpal bone with respect to others, or the linkage mechanism. The mechanism underlying movements of the hand with respect to the forearm has been hypothesized to be either a dual articular (fixed row), intercalated link, screw-vice, or columnar system (Kauer, 1986).

Dual articular concept. The carpus is able to transmit forces between the hand and forearm by utilizing a dual articular system (Tsumura et al., 1987; Weber, 1984, 1988). The most proximal joint in this system is the radiocarpal (RC) articulation, and the more distal is the midcarpal (MC) articulation; these joints are shown in Figure 2. Modest motion in one joint is amplified at the second joint without loss of stability (Weber, 1984). This system, unique within the body, adds a small range of motion at one articulation to the movement at a second articulation, so that the resultant ROM for the combined articulations is quite large. In the carpal system stability within the dual articulation is a matter of mechanical linkage (Weber, 1988).

The radiocarpal (RC) joint is formed by the radius proximally and the scaphoid, lunate, and triquetrum distally. The proximal joint surface has a single continuous biconcave curvature, which is long and shallow side-to-side (frontal plane), shorter and deeper anteroposteriorly (sagittal plane). This joint surface is composed of a lateral radial facet for the scaphoid, a medial radial facet for the lunate which articulates with

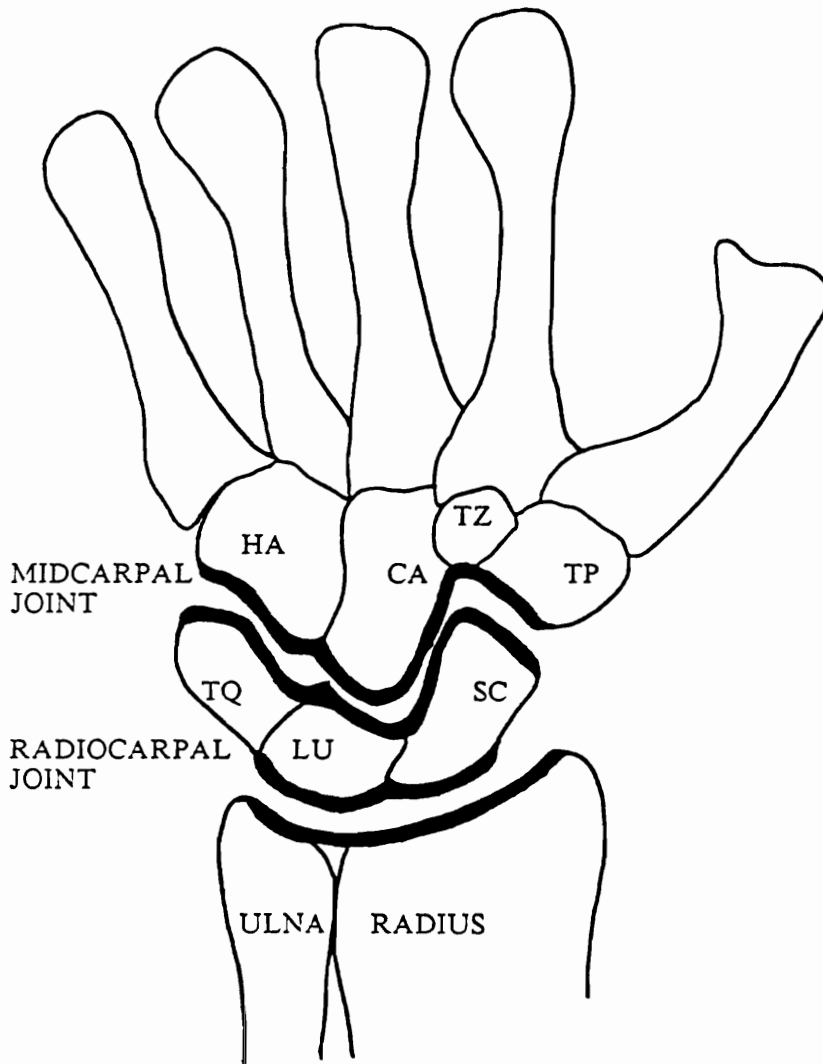

Figure 2. Wrist complex. The radiocarpal joint is composed of the radius on one side, the scaphoid (SC), lunate (LU), and Triquetrum (TQ) on the other side. The midcarpal joint is composed of the scaphoid, lunate and triquetrum against the trapezoid (TZ), capitate (CA), and the hamate (HA) (adapted from Norkin and Levangie, 1983).

the triquetrum. The ulna is not part of the articulation; the head of the ulna can actually be removed without impairing wrist function (Norkin and Levangie, 1983).

The differences in the curvature of the articular surfaces at the RC level individualize the movements of the proximal carpal bone and change the shape of the proximal carpal row during movements of the hand with respect to the forearm (Kauer and de Lange, 1987).

The midcarpal (MC) joint is a functional rather than anatomic unit. It does not form a single uninterrupted articulating surface nor have its own capsule as does the RC joint. The MC joint acts as a hinge joint and therefore is in itself capable merely of flexion and extension. It moves in conjunction with the RC joint to increase the range of these movements for the hand as a whole (MacConaill and Basmajian, 1977).

The MC joint consists of a series of tight-fitting, uniquely shaped contacts between proximal and distal rows. The distal joint surfaces are irregularly curved, which means that a shift of the proximal carpus relative to the distal carpus in flexion or extension influences the resulting position of the intercalated bone in a specific way (Kauer, 1974, 1980, 1986; Kauer and de Lange, 1987; Kauer and Landsmeer, 1981).

Wright (1935) states that flexion and extension are compound RC and MC movements. Starting from the neutral position, wrist extension is initiated in the midcarpal joint (Sarraffian et al., 1977). The total wrist extension is predominantly determined by the radiocarpal joint, with lesser amounts contributed by the midcarpal joint (Cailliet, 1971; Sarraffian et al., 1977). Flexion is the reverse of this sequence, initial movement taking place at the RC joint, with subsequent involvement of the MC joint (Sarraffian et al., 1977). Thus, with extension of the wrist, the proximal row moves forward upon its articulation in addition to rotation upon the distal end of the radius; the reverse is true in flexion (Fisk, 1984).

The relative contributions of the dual carpal articulation surface, the RC and MC joints, to wrist flexion, extension, and total range of motion (ROM) have been measured by many researchers. The results of these studies are summarized in Table 1. These

TABLE 1

## Contribution of Dual Articulation to the ROM

<i>Author(s)</i>	<i>Flexion</i>		<i>Extension</i>	
	<i>RC</i>	<i>MC</i>	<i>RC</i>	<i>MC</i>
Fick (1911, as cited by Ketchum et al., 1978); Kapandji (1968, 1987); Volz (1976); Von Lanz and Wachsmith (1959)	45-50 deg	30-35 deg	35 deg	50 deg
Sarrafian et al. (1977)	60 deg	40 deg	34 deg	66 deg
Bunnell (1948)	44 deg	22 deg	44 deg	34 deg
Kaplan (1965)	65-75%	25-35%	15-25%	79-85%
Cailliet (1971); Cunningham (1953)	RC > MC		RC < MC	
Fisk (1970)	50%	50%	66.6%	33.3%
Ruby et al. (1988)	RC = MC		RC = MC	
Wright (1935)	30 deg	50 deg	28 deg	16 deg
Horwitz (1940)	18 deg	67 deg	24 deg	33 deg
Gray (1977)	RC < MC		RC > MC	
Brumfield, Nickel, and Nickel (1966)	RC < MC		RC ≠ MC	

findings are contradictory and lead one to conclude that neither the quality nor quantity of component movement within the carpus is well understood and that while both the RC and MC joints contribute to the total ROM, these contributions may vary in magnitude throughout the ROM.

Intercalated link concept. Gilford, Bolton, and Lambrinudi (1943) described the scaphoid as unique in that it lies both in the proximal and distal rows and is found to share part of the movements of extension at the proximal joint and part of the flexion at the distal joint. When the position of the lunate is kept constant, radiograph tracings show the scaphoid to move an approximately equal amount on each side of the neutral position, about 20-deg each way. Thus, they conclude that the scaphoid acts as a bridge across the ligament sling and stabilizes the normal movements of the wrist, as well as protecting it against "crumpling" movements. This function can be symbolized by a bar attached to all the members of the joint by bands; these bands are loose enough for normal movements, but tighten at once when outside forces tend to crumple the limb in its unstable position, as shown in Figure 3.

The mechanical equivalent of the lunatocapitate joint (1) is a simple pivot placed at the center of rotation, whose other pivot at (2) in Figure 3 completes the analogy for the radiolunate joint (Gilford et al., 1943). Movements of flexion and extension of the wrist are thus simplified to those of a link joint, as shown in sections A, B, and C of the figure. Such a link mechanism provides several advantages: large movements of the joint are possible with a small ROM at one articulation enhanced by movement at the second articulation, large movements of the joints are possible with a small area of exposed cartilage, flatter joint surfaces are possible which withstand pressure better than a single more rounded joint, a minimum amount of skin is required to cover the surface of the bent joint, and pinching of the skin is minimized on the opposite joint surface (Gilford et al., 1943; Norkin and Levangie, 1983). The major disadvantage of the link joint system is that, without other mechanisms, this link joint system is only stable in

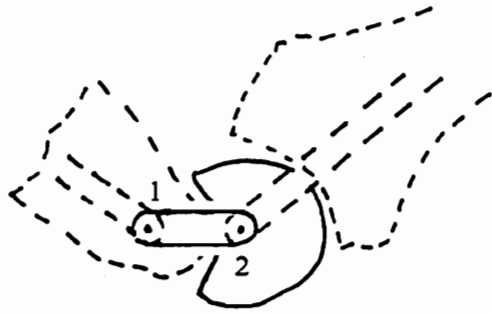

A. EXTENSION

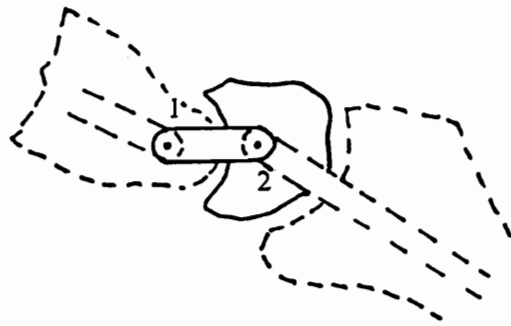

B. NEUTRAL POSITION

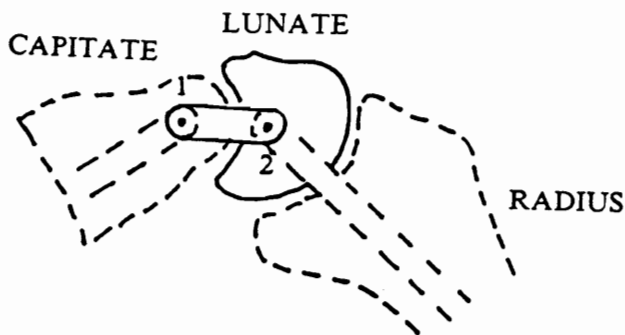

C. FLEXION

Figure 3. *The wrist as a link mechanism using the link concept of Gilford, Bolton, and Lambrinudi (1943), shown in extension (A), neutral position (B), and flexion (C). The lunatocapitate pivot (1) and radiolunate pivot (2) are the linkage points.*



tension; it is unstable to compression forces, which tend to crumple it (Gilford et al., 1943).

Muscles acting across a joint produce compression forces; therefore, to prevent crumpling of the link, some stabilizing mechanism must exist. If this stabilization were due to the coordination of the wrist muscles, subluxation (displacement) could easily be produced post mortem or under anesthesia (when muscles cannot be innervated), but Gilford et al. (1943) found subluxation to be impossible. No tendons are inserted directly into the carpal bones; thus, they cannot be the stabilizing mechanism. It follows that a fairly abrupt stop mechanism is required to prevent each joint from moving beyond a certain range and to allow a portion of the total ROM to occur at the radiolunate (RC) joint, and the other portion to occur at the lunatocapitate (MC) joint. This stop mechanism is achieved by lateral ligaments in combination with the shape of the joint surfaces (Gilford et al., 1943).

The MC joint consists of a series of tight-fitting, uniquely shaped contacts between proximal and distal rows. The distal joint surfaces are irregularly curved, which means that a shift of the proximal carpus relative to the distal carpus in flexion or extension influences the resulting position of the intercalated bone in a specific way (Kauer, 1974, 1980, 1986; Kauer and de Lange, 1987; Kauer and Landsmeer, 1981).

When the carpus is viewed as a system of three intercalated (linked longitudinal) chain links, the different movements of the intercalated segments change the shape of each longitudinal chain. The interdependence of the longitudinal chains, especially the capitate-lunate-radius chain (the central core), as demonstrated in the flexion and extension positions of Figure 3, results in mutual displacement of the scaphoid and lunate (Kauer, 1986). Neither the MC or RC displacements can be considered independent movements. A displacement at the RC level is followed immediately by a displacement at the MC level as a result of the mutual displacement of the intercalated proximal carpal bones (Kauer, 1986).

Screw-vice or clamp concept. The carpus can be considered to consist of two rows, each row having three bones in it and one bone (the scaphoid) being in common to both rows (the trapezoid, trapezium, and pisiform were neglected in this model) (Gilford et al., 1943; MacConaill, 1941). The muscular forces acting upon the metacarpal bones are transferred to the hamate, capitate, and trapezoid. These three bones rotate about an axis which passes through the head of the capitate and the glenoid fossa of the scaphoid which articulates with the capitate. The movement between these two bones is a twisting movement which tends to bring them into close contact. The ligaments which connect the capitate and scaphoid are not elastic and so draw the opposing surfaces together until they are at rest upon one another and are held together under pressure. When this state has been attained, the scaphoid bone must follow the movement of the capitate as it passes further into extension (MacConaill, 1941).

The hamate rotates with the capitate. Johnston (1907) stated that the articular facet on the hamate shows a groove starting from the proximal articulation, winding in a spiral fashion and terminating posteriorly, as if the bone had been caught at its apex and twisted. MacConaill (1941) confirmed this in further dissections, noting that the proximal articular surfaces of the hamate and capitate bones form, together, a very efficient screw surface. This screw surface is a male surface, the female surface is formed by the corresponding articular facets on the triquetrum and the lunate bones. MacConaill felt that the bones of the carpus are "welded together" in extension, that the bones become more closely packed in a two-stage process. In the first stage, the scaphoid is brought to rest on the distal row and so made effectively one with it; in the second, the lunate (and with it the triquetrum), is screwed against and brought to rest upon the scaphoid, which fulfills its role as a link between the two rows. During the second stage, the triquetrum is screwed towards the scaphoid, pushing the lunate with it.

This mechanism resembles a screw-vice or screw-clamp (MacConaill, 1941). The first stage of extension is one in which the clamp is set up by fixing the scaphoid (the fixed jaw of the vice) to the distal row which acts mechanically as the base of the vice.

In the second stage, the hamate acts as a screw to pin the lunate against the fixed jaw and to hold it there as long as extension is maintained.

Columnar concept. Navarro (1921, as cited by Viegas et al., 1987) introduced his concept of the columnar or vertical carpus, in which the scaphoid is a link between the proximal and distal rows. The columnar concept regards the bones of the wrist as being arranged vertically in three columns, proximally mobile and distally rigid, each of which serves a particular carpal function.

The lateral (radial) column is the most freely mobile and consists of the scaphoid and trapezium-trapezoid articulation. This column is chiefly concerned with prehension and the precision grip of the thumb and index finger (Fisk, 1984).

The central column consists of the lunate and capitate, and is involved with wrist flexion and extension. It is the site of carpal instability or zig-zag deformity, which profoundly affects the position and function of the rest of the wrist. As vertical force is directed along the axis of the capitate, its proximal pole tends to lodge itself between the scaphoid and lunate if the joint between them becomes lax (Fisk, 1984).

The third or medial (ulnar) column, comprised of the triquetrum and hamate, provides the axis of rotation of the forearm as it is extended on the carpus (Fisk, 1984).

Functional unit. The "functional unit" is a combination of three theoretical concepts, the intercalated link, screw-vice, and columnar concepts. This functional unit consists of three bones, the scaphoid, lunate, and capitate (Weber, 1984, 1988), as shown in Figure 4, which constitute Navarro's central control column (Fisk, 1984) for wrist flexion and extension.

Understanding the interactions of the scaphoid, lunate, and capitate with their neighboring bones is the key to comprehending how the wrist maintains its stability while allowing a wide ROM. The position of the scaphoid is dominated by its contacts with the distal carpal bones, with the radius, and by its link to the lunate. In flexion, tilting of the scaphoid is inevitable because of the impact of the trapezium and the trapezoid on the distal part of the scaphoid. The radiolunate motion may be taken as

representative of the radiocarpal motion, whereas the lunatocapitate motion may be taken as representative of midcarpal (MC) motion. The scaphoid anatomically and functionally belongs to both rows and changes sides as the wrist moves from flexion to extension. The respective interosseous ligaments convey the tilt of the scaphoid to the lunate and the triquetrum. The crucial point is that as a result of a difference in curvature between the proximal joint surfaces of the scaphoid and the lunate in the radiocarpal joint, these bones have to shift with respect to one another in flexion (Kauer and Landsmeer, 1981).

To facilitate the understanding of how joint contact acts to control the rotational shift of the intercalated segment, it is useful to employ to functional unit concept to the central core of the wrist (Weber, 1984). This central core is shown in a dorsal view in Figure 4. The central dorsal zone includes the scapholunate joint, lunate, capitate, and the base of the second and third metacarpals. The soft tissue structures in this zone are the distal aspects of the extensor carpi radialis brevis and longus (1) and the extensor digitorum communis tendons (2) (Brown and Lichtman, 1988).

The main function of the force-bearing column is to transmit the forces generated by the hand to the forearm unit. The articular chain that transmits loads begins at the carpometacarpal joints of digits two and three (index and middle fingers). The load is transmitted through the capitate to the lunate and proximal two-thirds of the scaphoid. The scaphoid and lunate transmit the load to the radius (Tsumura et al., 1987; Weber, 1984, 1988). All these surfaces interact to form the major force-bearing column of the wrist (Weber, 1988).

Summary. The intercalated link and screw-vice concepts are refinements upon the dual articular system. Each of these theories divides the carpus into rows at the RC and MC joints. The intercalated link is a mechanical representation of the control system of the dual articulation. It was devised to explain the effect(s) of outside forces upon the stability of the dual articulation. The screw-vice theory explains the contribution(s) of

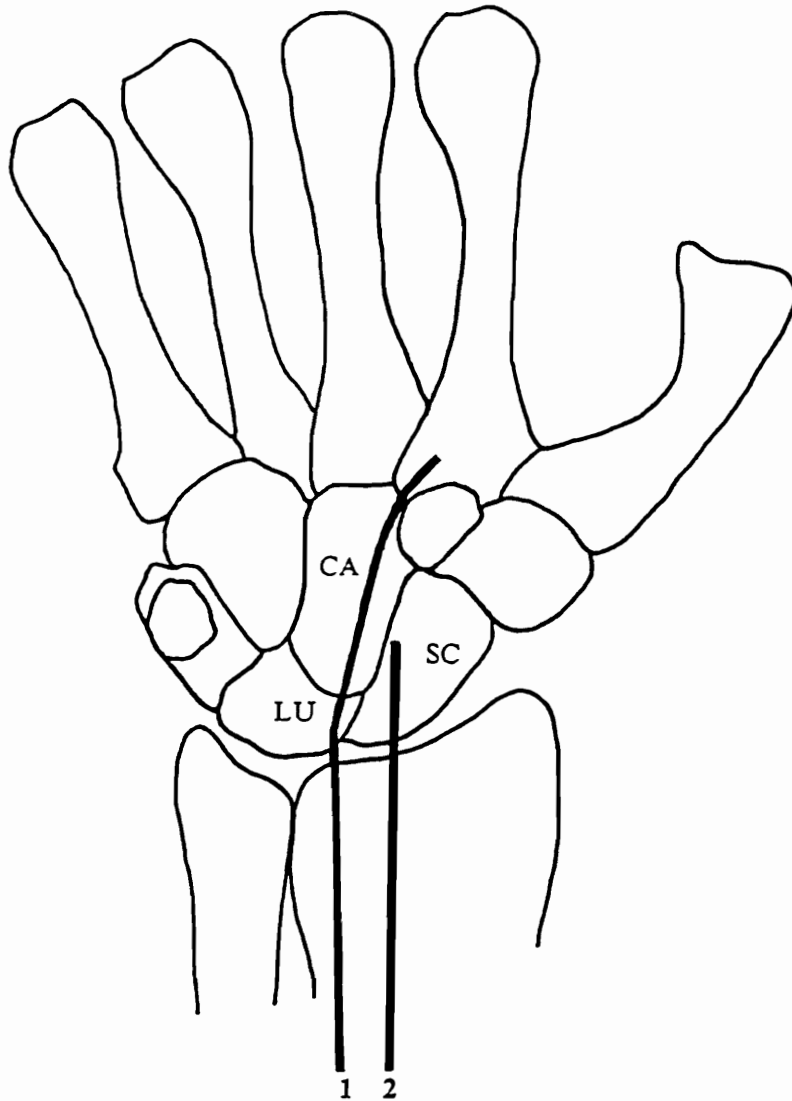

Figure 4. *Central dorsal zone. In this zone are the scaphoid (SC), lunate (LU), and capitate (CA) which are controlled primarily by the ECRB and ECRL (1), and the common finger extensors (2) (adapted from Brown and Lichtman, 1988).*

individual bones to movement within the RC and MC joints. Thus, the intercalated link and screw-vice concepts support and enhance the dual articulation concept.

The columnar concept, however, contradicts the dual articular system, in that the wrist is divided into columns rather than rows. Instead of explaining wrist motion, the columnar concept is concerned with wrist control. Each column controls an activity, either prehension and precision grip, carpal flexion and extension, or pronation and supination of the hand about the forearm.

The dual articular system and intercalated link concepts are the most widely accepted wrist articulation schemes. The screw-vice concept has been employed for certain surgical applications (Linscheid, 1986). The columnar concept has not been widely adopted, although it contributes to the notion of the functional unit.

The literature suggests that both the RC and MC joints contribute to, and may be the limiting factors of, the ROM. The changes in individual bone position and stabilizing tissues may influence the COR over the ROM. The application of outside force may change the joint system as well, causing the bones to become more closely packed or to transmit the force to other structures. Therefore, the dual articulation, intercalated link, and screw-vice systems are employed in this study as the theoretical foundation for ROM, for COR location, and force generation analyses in wrist flexion and extension.

### Range of Motion

The wrist is biaxial, with motions of flexion (volarflexion) and extension (dorsiflexion) around a coronal axis, and deviation (radial and ulnar) around an anteroposterior axis. The entire range of motion is made up of contributions, in various proportions, of RC and MC joint movement, as shown in Figure 3, Figure 5, and detailed in Table 1.

The range of motion (ROM) is the angle included between extreme flexion and extension that can be achieved with no discomfort. The angle between these extreme positions is measured with reference to neighboring body segments (in this case forearm

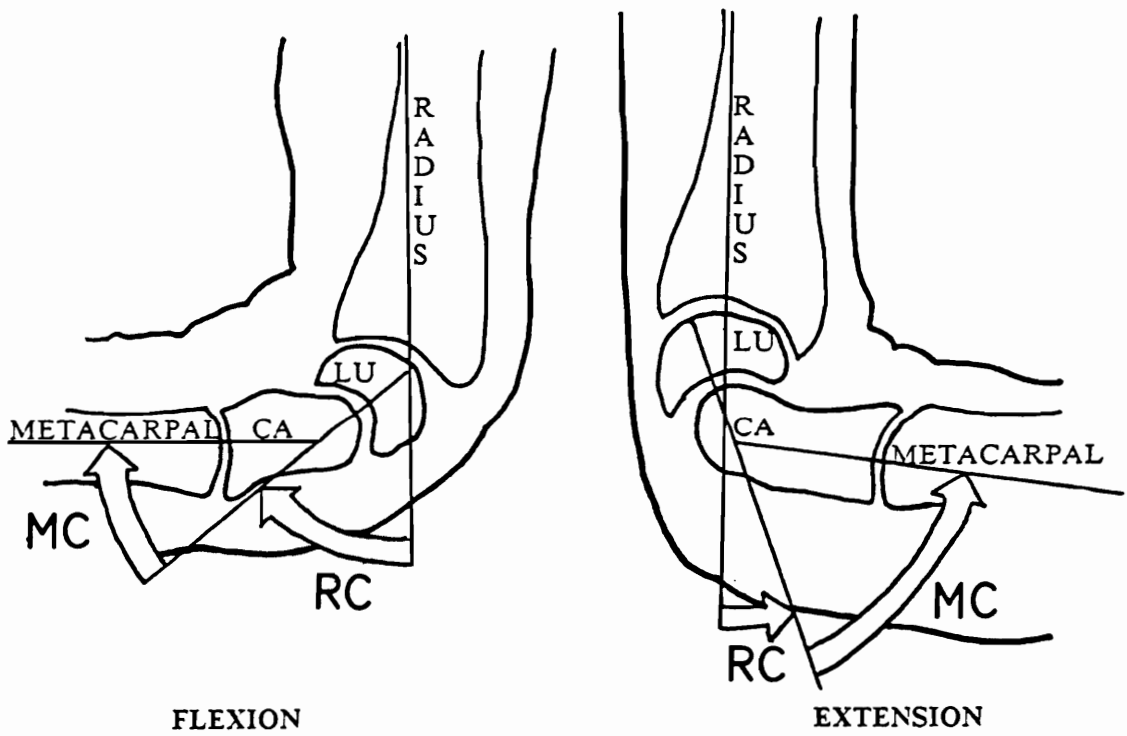

Figure 5. The position of the radius, lunate (LU), capitate (CA), and metacarpals when the wrist is in extreme flexion and extension (adapted from Kapandji, 1970).

and hand), about their common point of rotation, as shown in Figure 5 which depicts extreme carpal flexion and extension.

ROM measurement can be classified as either active or passive. Active ROM is defined as that range which subjects can achieve on their own with no external support, not even from their other hand. In contrast, passive ROM is that range which can be achieved when external force and support are given, limiting the effect of both motivation and strength of the subject, testing only the passive restraint system within the joint (Brand, 1985). Although many researchers have measured active ROM, the results are diverse as shown in Table 2. The average passive ROM, as measured by Kapandji (1987), was 90 deg in flexion and 110 deg in extension; the passive range of motion allowed by the carpal joints is larger than in active generation.

This study is concerned with active force generation; therefore, active ROM is of interest. ROM varies among individuals and may be a function of gender, age, and physical build (Brumfield et al., 1966). Thus, several of these variables will be included in the present study.

Woodson (1981) and Staff (1983, as cited by Kroemer et al., 1986) both stated that females had a larger flexion-extension ROM than males, with the average difference in flexion and extension measured as 14 deg overall (Woodson, 1981), divided into 10 deg for extension and 4 deg for flexion by Staff (1983).

To verify these generalizations, the coefficients of correlation between ROM and gender, as well as between each anthropometric variable and ROM, will be calculated and evaluated in this study and prediction equations of ROM based upon some or all of these variables will be generated.

#### Center of Rotation

Movements of the wrist joint are complex and, in a normal stable joint, many movements are going on at the same time (Fisk, 1981). Serial radiographs of the carpus in various positions, examined by Gilford et al. (1943), show that all essential flexion and extension movements take place in the radiolunate and lunatocapitate joints, as



TABLE 2

Active Range of Motion. Averages for Flexion, Extension, and Entire Range

<i>Author(s)</i>	<i>Flexion</i>	<i>Extension</i>	<i>Total</i>
Brumfield, Nickel, and Nickel (1966)	82 deg	72 deg	154 deg
American Assoc. of Orthopaedic Surgeons, as cited by Brumfield et al. (1966); Cailliet (1977)	80 deg	70 deg	150 deg
Ruby et al. (1988)	---	---	112 deg
Kelley (1971)	85 deg	85 deg	170 deg
Norkin and Levangie (1983)	85 deg	70-80 deg	155-165 deg
Bunnell (1948)	60-70 deg	70-80 deg	130-150 deg
Rowe (1985)	60-90 deg	60-90 deg	120-180 deg
Woodson (1981)	90 deg	99 deg	189 deg
Hazelton, Smidt, Flatt and Stephens (1975)	68 deg	57 deg	125 deg
Bradley and Sunderland (1953)	---	---	131 deg

shown in Figure 3. They found that both joints have about the same range of movement and each has a single center of rotation demonstrating the dual articular and intercalated wrist linkage systems.

Flexion and extension of the hand upon the forearm consist of angular displacement of the RC and MC joints. Youm and Yoon (1979) described this path as an almost perfect arc of a circle in flexion and extension; thus, a single center of rotation (COR) may be located for this arc. If this path of motion is an arc, a single COR can be located, else a series of points each representing an ICOR must be located. At every angle of wrist flexion or extension, a single instant center of rotation (ICOR) can be located for the total wrist complex.

Despite the complexity of wrist action, Fisk (1981, 1984), Linscheid (1986), and Volz, Lieb, and Benjamin (1980) located the COR for flexion and extension in the neck of the capitate, identified as region A in Figure 6. The ICOR for flexion and extension has been located as a point in the head of the capitate by Volz (1976), Youm and Yoon (1979), and MacConaill (1941), and as a very small grouping of points very close to the articular head by Youm, McMurtry, Flatt, and Gillespie (1978), although no measurements were recorded. These positions found in the literature are identified as region B in Figure 6.

Dempster (1960) used the Method of Reuleaux to define rotation in one plane, in terms of ICOR points for the wrist, and to analyze 15 X-ray exposures of the wrist in flexion and extension. This analysis showed a cluster of ICOR points ranging over a 1.90 cm diameter circle within the carpus, centered over the lunatocapitate junction identified as region C in Figure 6.

Bunnell (1948) located the COR in a position other than the lunatocapitate region. He stated that the COR of flexion and extension motion seemed to be at the level of the distal volar crease, where the two volar creases of the wrist mark the upper and lower limits of the lunate bone. This point is labeled D in Figure 6.

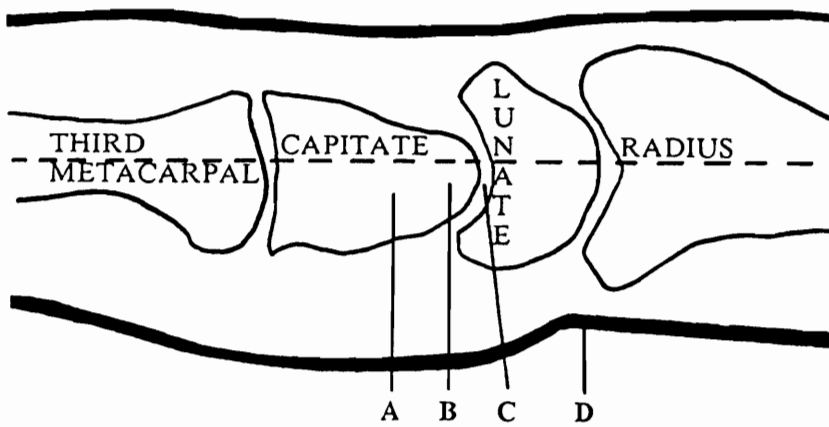

Figure 6. Center of rotation of the wrist, located in the neck of the capitate (A), head of the capitate (B), lunatocapitate joint (C), or volar crease (D).

COR location measures have only been taken in a no-load condition; that is, the only force acting on the hand and forearm is due to the inertial properties of the segments. The COR in a loaded condition, one in which there is an external force applied to either the hand or forearm, has not previously been measured. Thus, the literature gives no information on whether the ICOR for the loaded condition is the same as in a no-load condition for each subject, nor if it differs from subject to subject.

Based upon kinematic linkage theories in the literature, the COR over the total ROM would not be expected to be a single point. The dual articular, intercalated link, and screw-vice linkages lead to changes in individual bone position, changes in percentage of contribution for the RC and MC joints, and interaction between the joints and stabilizing tissues. These changes could affect the location of the COR over the ROM. The outside forces applied may affect the bone packing and the shape of the joints, in turn affecting the COR. Thus, a study to determine the distance of the ICOR points from the COR, which has been hypothesized to reside in the head or neck of the capitate, was performed with three load conditions, no-load, a dorsal load, and a palmar load.

### Force Generation

Maximal voluntary contraction. Muscular strength is operationally defined as a subject's capability for the exertion of force or torque to an external measurement device over a specified period of time (Kroemer and Marras, 1981). The muscle contraction effort is ultimately limited by the given structural (biomechanical) strength of the muscles, tendons, cartilage, bones, etc., in the body parts involved, taking into account such postural mechanical advantages as pull angles, lever arms about articulations, etc. Clearly, the true maximal strength capability usually cannot be tested in living human subjects (Kroemer and Marras, 1981). Since this study deals with measurements to be taken on live subjects, the maximal measured contraction will be less than the structural limit. The technical term for this submaximal exertion is "maximal voluntary contraction" (MVC) (Kroemer and Marras, 1981).

Factors affecting force exertion. The force that each individual exerts is a function of physiological and psychological factors. The physiological factors, such as physical condition of the subject, gender, body posture, use of the Valsalva maneuver, practice of the skill to be performed, and/or sensory stimulation, can either be measured or controlled by the experimenter. The psychological factors, motivation, knowledge of results and/or mental conditioning, are much more difficult (or impossible) to measure and difficult to control (Kroemer et al., 1986; Stegemann, 1981).

The "strength" of each muscle/tendon unit has been studied in cadavers. However, the contraction combinations which control the wrist movement mechanism cannot be examined without internal innervation; thus, these "strengths" are of little use to the industrial ergonomist (Brand, 1985; Gilford et al., 1943). The flexors are more powerful than the extensors (Thompson, 1981); based upon physiological cross-sectional area, the wrist flexors have more than twice the capacity of the extensors (Brand, 1985; Norkin and Levangie, 1983).

On the average, female strength has been found to be approximately two-thirds that of males; however, there is a large overlap in gender strength distributions and there are many females stronger than males (Chaffin and Andersson, 1984; Roebuck et al., 1975). Average grip and pinch strengths for females are between half to two-thirds those of males (Sanders and McCormick, 1986). An et al. (1986) found that females could generate 60 percent of the torque that males could generate in maximal wrist flexion and extension.

Digit, hand, wrist, and elbow position influence peak pinch and grip strengths (Anderson, 1965; Hazelton et al., 1975; Kraft and Detels, 1972; Mathiowetz et al., 1985; Pryce, 1980; Skovly, 1967; Woody and Mathiowetz, 1988).

Subjects tend to hold their breath during MVC, although most are unaware that they are doing it. This phenomenon is called the Valsalva maneuver and is characterized by a closed glottis while attempting exhalation (Astrand and Rodahl, 1986; Pryce, 1980; Stegemann, 1981). The effect of the Valsalva maneuver on MVC is not known at this

time; however, any possible effect(s) can be easily minimized by instructing the subjects to exhale at the beginning of the exertion and breathe normally throughout the static exertion.

The physiological factors were controlled in this study by subject selection and instructions given to the subjects. The psychological factors were controlled by employment of a set of "neutral" instructions, according to the Caldwell regimen (Caldwell, Chaffin, Dukes-Dobos, Kroemer, Laubach, Snook and Wasserman, 1974).

Measured flexion and extension forces. Only one study was found in the literature which measured torque generation in wrist flexion and extension; it employed static measurement of the intrinsic and extrinsic digital muscles and the wrist-dedicated muscles (An, Askew, and Chao, 1986). These results are shown in Table 3. In this study, An et al. (1986) found that on average the flexion torque was twice that of extension and that female torque magnitudes were about 60 percent of the torque males could generate. Both of these findings support previous findings in the literature.

The forces that can be generated by the wrist-dedicated muscles alone have not been studied. Force generation has been hypothesized to be a function of anthropometric dimensions, gender, and limb position (An et al., 1986; Anderson, 1965; Brand, 1985; Chaffin and Andersson, 1986; Hazelton et al., 1975; Kraft and Detels, 1972; Kroemer et al., 1975; Mathiowetz et al., 1985; Norkin and Levangie, 1983; Pryce, 1980; Sanders and McCormick, 1986; Skovly, 1967; Thompson, 1981; Woody and Mathiowetz, 1988). To evaluate these anthropometric variables with respect to force generation, a study was performed, with flexion and extension forces measured at a number of wrist positions, for both male and female subjects.

TABLE 3

Static Wrist Torques. Measured in Nm (An, Askew, and Chao, 1986)

<i>Gender</i>	<i>Hand</i>	<i>Flexion</i>	<i>Extension</i>
Male	Dominant	1.98 ± 0.72	1.02 ± 0.30
Male	Non-Dominant	1.96 ± 0.46	0.93 ± 0.23
Female	Dominant	1.11 ± 0.25	0.53 ± 0.16
Female	Non-Dominant	1.03 ± 0.20	0.51 ± 0.13

## METHOD

### Apparatus

A flexion-extension force measurement apparatus (FEFMA) was designed to measure the instant center of the rotation (ICOR) and the force generated in flexed and extended wrist positions. The basic elements of the FEFMA were adapted from a similar device employed by the Mayo Clinic Biomechanics Laboratory (An et al., 1986).

The FEFMA consists of a box which secures the forearm and assures constant upper limb posture, a pair of force transducers, a handle (proximal to the metacarpophalangeal joint) which contains pen holders and which is connected to the force transducers, a flat ROM and ICOR recording surface, and a pivoted pulley system for external loading.

In this study, the forearm was secured in the metal box between adjustable pads which held the distal forearm midway between pronation and supination. The proximal forearm was positioned by packing the area between the walls of the box and the forearm with foam padding. This box (shown in Figure 7) secured the forearm into a standardized posture and allowed no appreciable motion of the forearm during the measurements.

The handle structure consists of two plates designed such that one plate rests on the palm and the other on the dorsal side of the hand, both proximal to the metacarpophalangeal joint. Each plate was 12 cm long and the spacing between them could vary between 2.5 and 3.6 cm. These measurements correspond with the 5<sup>th</sup> percentile female through the 95<sup>th</sup> percentile male measurements for hand breadth and thickness. The plate separation was adjusted for each subject so that maximal force exertion was not limited by hand slippage or by pain. The entire handle was padded with a thin layer of foam to cushion pressure points along the metacarpals to prevent slippage and pain. The dorsal side of the handle had a distal extension plate which was parallel to the long axis of the third metacarpal. This handle extension plate had two



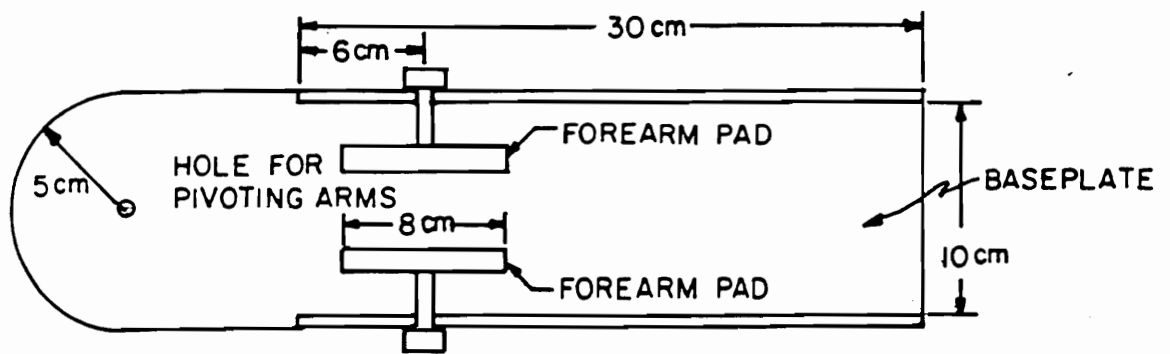

Figure 7. Forearm securing box.

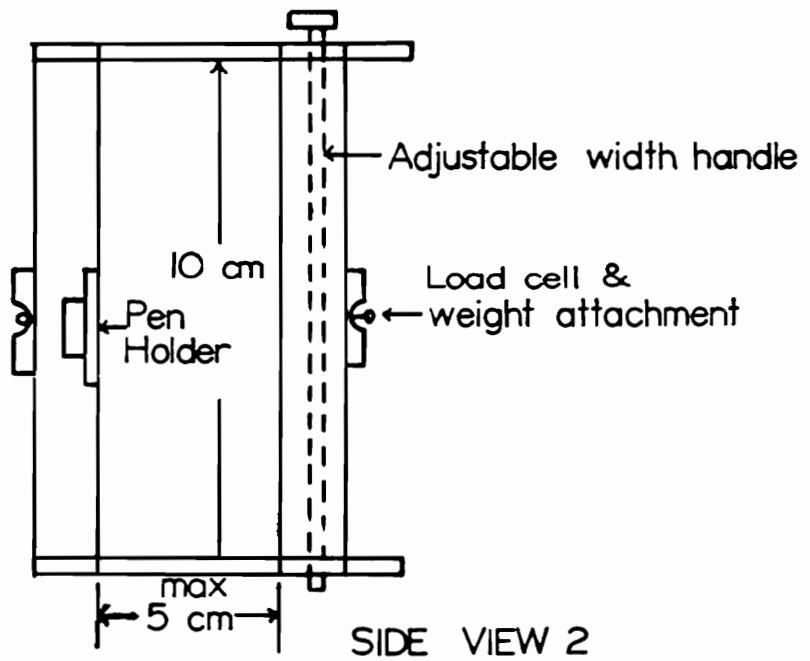
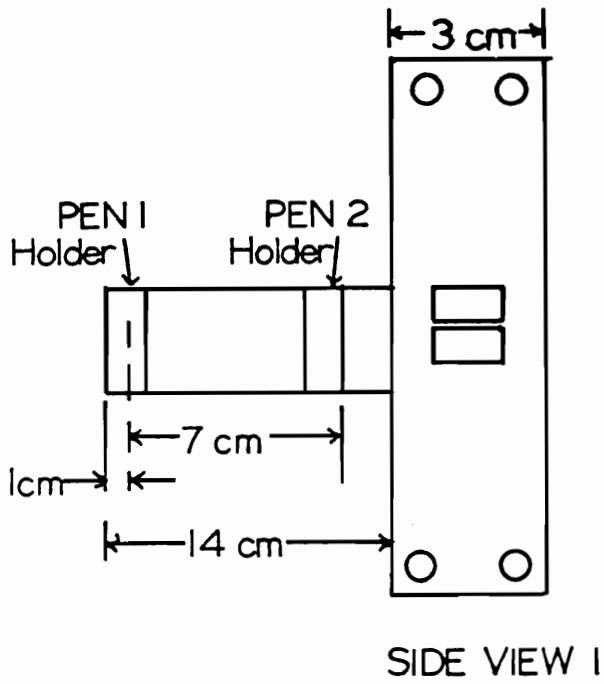

Figure 8. Handle schematic.

pen holders, separated by 7 cm, to record the raw data required for the Method of Reuleaux. This handle is shown in Figure 8.

The handle was located 8 cm from the reference point center of rotation, an artificial COR. The distance for this moment (lever) arm was calculated by using the 5<sup>th</sup> percentile female palm length. During the ICOR measurements, the middle two fingers (digits 3 and 4) were secured to the padded pen holder extension to stabilize the pens.

The ICOR measurements were taken with the forearm secured and the ICOR measurement apparatus connected to this box, as shown in Figure 9. The ICOR data were collected on a flat measurement board. The ICOR measurement with a load requires that a force act perpendicular to both the long axes of the third metacarpal and the handle. For this, the handle was connected to a cable, which passed over a pulley with low friction bushings and was attached to a suspended mass. There were two paths for the cable, one for dorsal load and one for the palmar load condition.

The ICOR apparatus, with experimental subject secured, is shown in Figure 10. This photograph demonstrates the ICOR apparatus in use, drawing the arcs to determine the ICOR points by the Method of Reuleaux.

Once the ICOR measurements were completed, the measurement board and pulley system were removed from the box (which was securing the forearm) and the pivoting arm with force transducers was attached to the box and handle.

Force generated in the wrist was transmitted via turnbuckles from the handle to either of the force transducers (LeBow load cells, 136 kg capacity, Model #3397). These load cells were mounted on a pivoting arm to keep the line of force application perpendicular to the load cell, as well as perpendicular to the long axis of the third metacarpal, for each measurement position. This pivoting arm was fixed in each measurement position. One force transducer measured extension, the other flexion force, in each position, as shown in Figures 11 and 12. The transducer voltage output was amplified and converted into a digital signal utilizing a Metrabyte<sup>®</sup> A/D Converter. This signal was then stored on an IBM PC, as a function of time. The computer

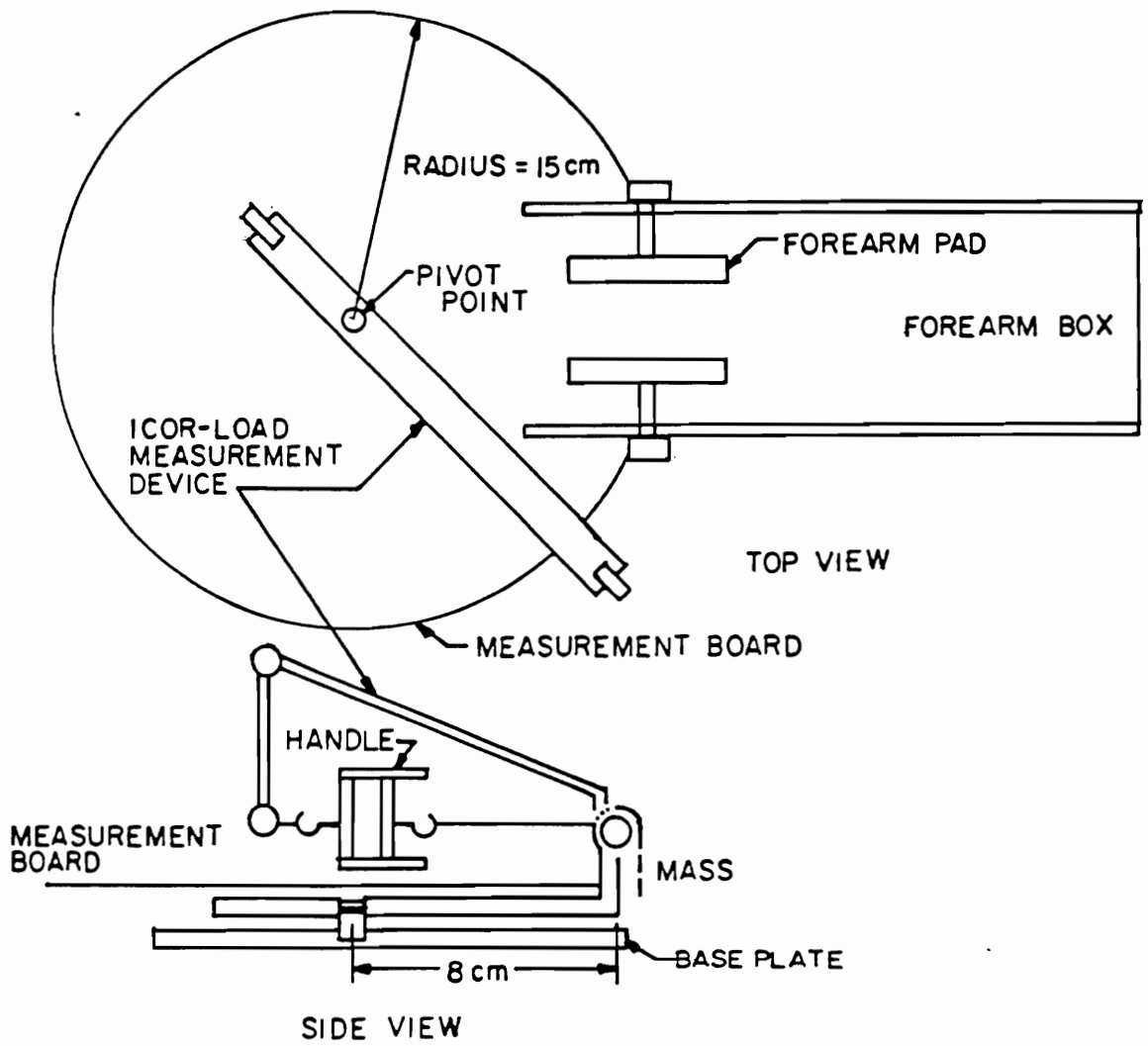

Figure 9. Schematic of the ICOR measurement apparatus.

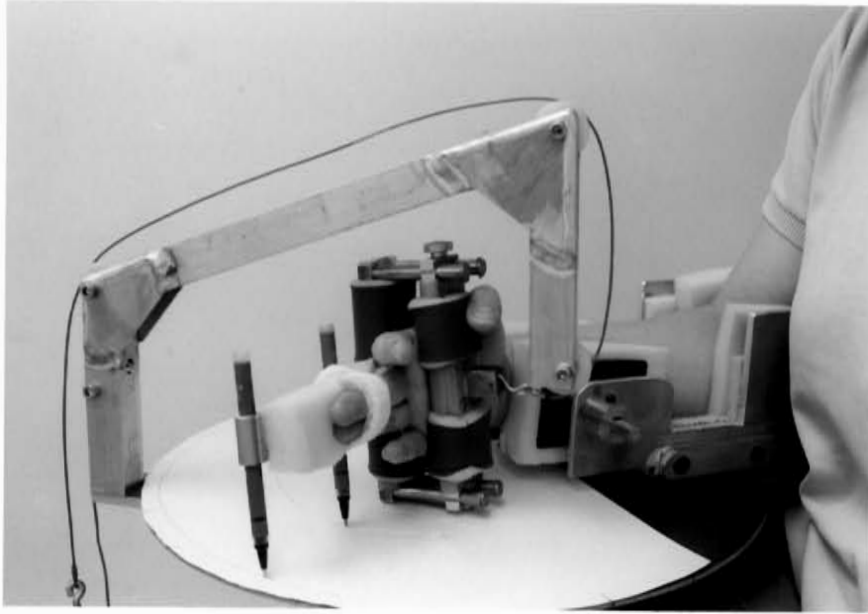

Figure 10. *Photograph of the ICOR apparatus.*

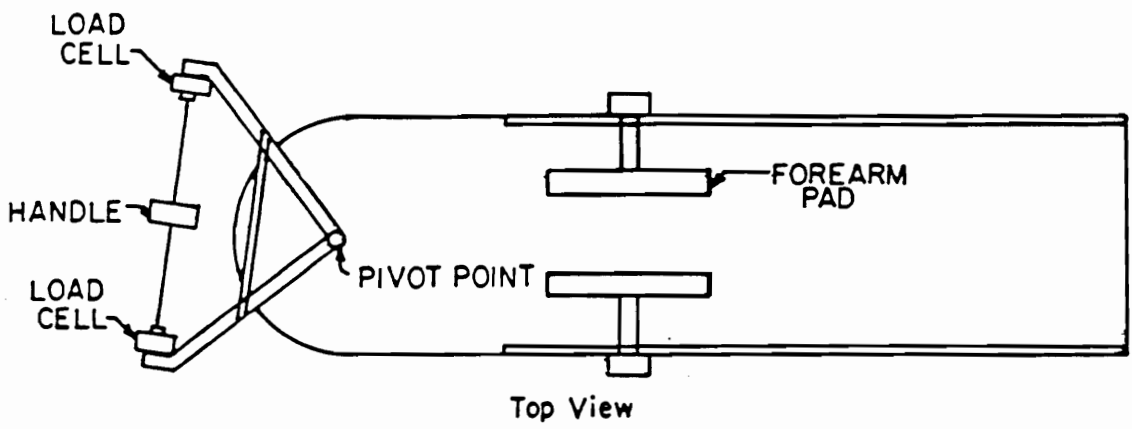

Figure 11. Schematic of the force measurement apparatus.



Figure 12. *Photograph of the force measurement apparatus.*

program employed to record the forces is shown in Appendix B. This program sampled 4500 points over a three-second interval then calculated the average force and the peak force. The peak force value was required to lie within a  $\pm 10$  percent bandwidth of the calculated mean. The data sampling rate was 1500 data points per second, well above what was believed to be necessary to record all force fluctuations. Calibration of each load cell was accomplished by hanging a series of known weights from the FEFMA, examining the resulting voltage, and comparing it with the standard (known) weights.

### Subjects

Sixty right-hand dominant subjects (30 male and 30 female) between 20 and 30 years of age voluntarily participated in this study contingent upon positive palpation of the palmaris longus muscle of the subject. Each subgroup was kept as homogeneous as possible by limiting the range of age and selecting only right-hand dominant subjects all having the six wrist-dedicated (carpi) muscles.

### Procedure

The subjects read and signed an informed consent agreement, which included the statement that they are not limited by any orthopedic dysfunction, especially within the upper limb. The consent form is contained in Appendix C.

Anthropometric measurements taken were height, weight, forearm length, forearm girth (distal and proximal), wrist breadth, wrist thickness, wrist circumference, hand length, and hand breadth. These measures were gathered using the landmarks and procedures described in the NASA Sourcebook (1978, Publ 1024), employing calipers and anthropometers as required.

Range of motion. The active ROM in flexion and extension for a no-load condition was measured. The ROM was the angle included between extreme active flexion and extension that can be achieved with no discomfort. To accomplish this measurement, the forearm and hand of the subject were positioned such that the angle between the long axis of the ulna and third metacarpal could be measured with a goniometer. The fulcrum for position measurement was the ulnar styloid, with one arm of a goniometer



placed parallel to the long axis of the ulna, and the other parallel to the long axis of the third metacarpal. This position has been defined as the neutral position (Esch and Lepley, 1973) and was the zero point for all measurements taken.

Instant center of rotation and force measurements. Each subject was seated in a chair with the upper body in a standardized upright position. This position specified that the upper arm of the subject should be relaxed, hanging vertically (with no shoulder adduction nor abduction), the elbow joint flexed with a 90-deg included angle. The hand and arm of each subject were then placed in the FEFMA for ICOR and force measurements. After securing the forearm of the subject, the wrist was fixed in the device, such that the hypothesized center of rotation (located in the head or neck of the capitate) was directly over the pivot point for the ICOR load arm and the pivot point for the force transducer arms. The hand was inserted into the handle.

Raw data for the Method of Reuleaux were collected after the subject's hand was restrained in the handle, digit 3 (and digit 4 for small hands) secured to the pen holder extension plate, and the pens were inserted into the penholders. Each subject then slowly moved his or her hand through the ROM.

A series of wrist positions was located and referenced to the neutral position (known as the zero-deg point in this study). After the active ROM was measured on an individual, a series of positions were located at 15-deg intervals, beginning at the neutral position, up to and including the extreme flexion and extension points. Thus, the number of wrist positions located depended upon the individual ROM.

There were six experimental conditions for each wrist position; three load conditions combined with two directions of movement. The first load condition was that of no-load, where the only external force acting on the forearm-hand segment was due to inertia. The second was a loaded condition, where an external load of 20-N acted upon the dorsal forearm-hand segment. In the third load condition, an external 20-N load acted upon the palmar side of the forearm-hand segment. Each load condition was tested in two directions, one from full flexion to full extension, and the other from full

extension to full flexion. Thus, six sets of arcs were recorded for each subject and analyzed using the Method of Reuleaux.

Reuleaux (1876, as cited by Dempster, 1955, 1960; Frankel and Nordin, 1980), a German engineer, devised a method of locating the instant center of rotation for any body moving in a plane relative to points that are stationary on the plane. According to this method, the ICOR is found by identifying the displacement of two points on a link as the link moves from one position to another. The points on the link in its original position and in its displaced position are drawn on paper and lines are drawn connecting the two sets of points. The perpendicular bisectors of these two lines are then drawn. The intersection of the perpendicular bisectors locates the ICOR.

The Method of Reuleaux may be applied to joint movement if one member of the joint systems is held stationary while the other moves. As the moving member rotates through its range, the position in the plane of movement of two (or more) points may be determined for a series of successive instants during the movement (Dempster, 1955). In this study, as in Dempster's (1955, 1960), secondary movements of the wrist have been ignored, considering only the major movement in a plane of reference perpendicular to the axis of flexion and extension. Pens spaced along the handle extension (in the pen holders) produced the raw data for analysis with the Method of Reuleaux. After the arcs were drawn on graph paper, the x and y coordinates were recorded, 5-deg on either side of the wrist position to be evaluated. These coordinates were then input into a computer program which determined the perpendicular bisector intersection in radial distance from the reference axis point. This program is shown in Appendix D.

Flexion and extension of the wrist, utilizing only the carpi muscles, were measured in the same wrist positions defined for the ICOR measurements. To eliminate any order effects on the force measurements, the wrist position order was randomized by the computer program shown in Appendix B.

Once the wrist was positioned in the FEFMA, the subject was instructed to exhale (to prevent a Valsalva maneuver) and simultaneously to maximally flex or extend the

wrist, using only those muscles directly affecting the wrist. The subject was instructed to relax the fingers, not to stiffen, flex, or hyperextend the digits to prevent recruitment of the digital muscles. Figures 13 and 14 show a subject exerting force with the digits relaxed.

The force generation measurements followed a modified Caldwell Regimen (Caldwell et al., 1974) developed by the Virginia Polytechnic Institute and State University Industrial Ergonomics Laboratory in 1987. This protocol, modified for the smaller number of both muscle groups and fibers involved, called for a slow build-up to peak force (MVC), sustaining that peak for three seconds, with a slow return to a relaxed state (Berg, Clay, Fathallah, and Higginbotham, 1988). Since only two force exertion measurements (flexion and extension) were taken at each position, a one-minute rest period was provided between each exertion as suggested by Chaffin (1975). The time required to reposition the wrist was at least one minute; thus, fatigue should not have affected the MVC values.

During the three-second sustained exertion phase, the measured peak force was required to lie within a  $\pm 10\%$  band about the average sustained force for that exertion. If this requirement was not met, the static exertion was performed again until this criterion was met.

#### Experimental Design

Range of motion. The dependent variable in the experimental design is ROM and the independent variables are gender and each of the eight anthropometric dimensions. The anthropometric dimensions are forearm length, proximal forearm circumference, distal forearm circumference, wrist breadth, wrist thickness, wrist circumference, hand breadth, and hand length. Gender and each anthropometric dimension act as factors in an incomplete  $2^9$  within-subjects design.

Instant center of rotation. The dependent variable in a  $2 \times 30 \times 7 \times 2 \times 3$  mixed-factor, full-factorial experimental design is the distance between the hypothesized COR and the calculated ICOR points. The independent variables are gender, subject, wrist

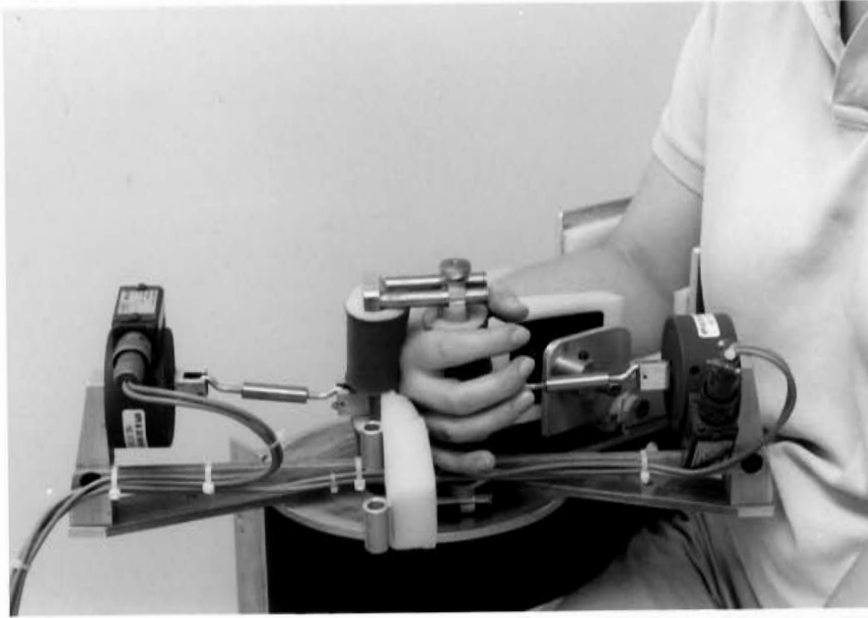

Figure 13. *Side-view of the force measurement apparatus during subject force exertion.*



Figure 14. *Top-view of the force measurement apparatus during subject force exertion.*

position (WP), direction of force exertion (D), and load (L), respectively. The between-subject factors are gender and subjects, with subjects as the only random effect. The within-subjects factors are WP, D, and L. WP has 7 levels, i.e., 45-deg flexion, 30-deg flexion, 15-deg flexion, neutral position (0-deg), 15-deg extension, 30-deg extension, and 45-deg extension. Direction of force exertion (D) has two levels. The first level of D consists of the subject at full wrist flexion moving to full extension, and the second level begins at full extension and moves to full flexion. The three load (L) levels are a no-load condition, a 20-N load applied to the dorsal side of the handle, and a 20-N load applied to the palmar side of the handle.

Force. The measured force for the 60 subjects acts as the dependent variable in a 2 x 30 x 13 x 2 mixed-factor, full-factorial experimental design. The independent variables are gender, subjects, wrist position (WP), and direction of force exertion (D), respectively. There are 13 levels of WP corresponding to the 13 possible positions from 90-deg flexion to 90-deg extension in 15-deg increments. At each WP, each subject performs static flexion and extension exertions which are the two levels of D.

#### Analysis

Range of motion. Gender and anthropometric dimension effect(s) upon the ROM are determined by three methods: correlation analysis, regression analysis, and ANOVA.

A Pearson product-moment correlation is performed to examine the linear relationship between each anthropometric dimension and the ROM. These correlations are performed separately for males and for females.

The regression analysis employs ROM as the dependent variable and the anthropometric dimensions as independent variables. Separate regression analyses are performed for male data only, female data only, and the combined group data.

For the ANOVA on the dependent variable ROM the independent variables are anthropometric dimensions. Anthropometric dimensions are continuous data. Therefore, in order to establish two discrete levels of each factor, each anthropometric variable is dichotomized. The first of the two levels of each anthropometric variable

consists of those values which are less than the mean dimension and the second level consists of those values greater than or equal to the mean dimension. The ROM is measured on all (60) subjects; however, the levels for each anthropometric dimension within each subject are determined by individual characteristics. Therefore, not all of the cells in the  $2^9$  design have data in them, while other cells have more than one data point within them.

Instant center of rotation. In order to determine if the wrist has a single COR or a series of ICOR locations over the ROM and whether load or direction of exertion affect the ICOR location, the data collected in this study are analyzed using ANOVA. The full-factorial ANOVA employs the  $2 \times 30 \times 7 \times 2 \times 3$  mixed-factor design described in the experimental design. Post hoc tests are performed on all significant factors.

Force. In order to evaluate the effect(s) of each anthropometric dimension, gender, wrist position, and force exertion direction on maximum force generation, the data collected in this study are analyzed using three methods: correlation analysis, regression analysis, and ANOVA.

The Pearson product-moment correlation is performed between each pair of anthropometric variables, ROM, average flexion force, and average extension force. Separate correlations are performed for data from the male and female subjects.

Regression models are developed separately for the dependent variables of flexion and extension forces. These models employ three data sets: males only, females only, and the total subject sample. The independent (predictor) variables are wrist position (as a percentage of individual ROM), forearm length, distal forearm circumference, proximal forearm circumference, wrist breadth, wrist thickness, wrist circumference, hand length, and hand breadth. In addition, each data set is also modeled using wrist position (as a percentage of ROM) as the only predictor of flexion and extension forces.

A full-factorial ANOVA procedure is performed on the  $2 \times 30 \times 13 \times 2$  mixed-factor design described in the experimental design. Post hoc tests are performed on all significant factors.

## RESULTS

### Comparison of the Subject Pool to Population Norms

The mean age of the male subject sample was 23.17 years, with a standard deviation of 2.00 years; the female subject mean age was 23.67 years, with a standard deviation of 2.76 years. The anthropometric measurements collected from the subject population were compared to tabulated data, which consist primarily of military subjects (Garrett, 1970a, 1970b, 1971; NASA, 1978). The NASA sourcebook (1978) for anthropometric dimensions contains data on a number of populations, including U.S. military personnel. Since the subject sample was similar in age and composition to enlisted Army personnel, the (subject) sample data were compared to these enlisted male and female personnel data where possible. The distal forearm circumference was not recorded for any population. In addition, female Army personnel data did not contain dimensions for the proximal forearm circumference, wrist circumference, and hand length. Therefore, the 1940 Department of Agriculture (NASA, 1978) dimensions were employed for diimension comparisons. Similarities or differences between the sample and the (comparison) population data were determined by testing for both sample means and for homogeneity of variance.

Anthropometric dimensions on the distal upper limb (forearm length, proximal forearm circumference, distal forearm circumference, wrist thickness, wrist breadth, wrist circumference, hand length, and hand breadth), stature, and weight were gathered on each subject. The raw data for each subject are shown in Table 21 for females and Table 22 for males (Appendix E). The mean and standard deviation of each anthropometric dimension, categorized by gender, were calculated using the Statistical Analysis System (SAS, 1989). The means and standard deviations for the subject sample and military population, for each anthropometric dimension, are tabulated in Table 4 for males and Table 5 for females.

The null hypothesis (of equal means) is rejected ( $\alpha \leq 0.05$ ) for female proximal forearm circumference, female wrist circumference, female stature, male forearm



TABLE 4

Male Anthropometric Dimensions. Means and Standard Deviations of Sample and Population Data

<i>Anthropometric Dimension</i>	<i>Subject</i>		<i>Military</i>	
	<i>Mean</i>	<i>Std Dev</i>	<i>Mean</i>	<i>Std Dev</i>
Forearm Length (FL) (cm)	29.10	1.62	28.13	2.18
Distal Forearm Circumference (FCD) (cm)	24.05	2.01	---	---
Proximal Forearm Circumference (FCP) (cm)	27.77	1.76	27.48	1.78
Wrist Breadth (WB) (cm)	5.84	0.28	5.69	0.32
Wrist Thickness (WT) (cm)	3.91	0.25	---	---
Wrist Circumference (WC) (cm)	17.07	0.75	17.14	0.85
Hand Breadth (HB) (cm)	8.72	0.49	8.89	0.46
Hand Length (HL) (cm)	19.30	7.60	19.61	6.66
Stature (cm)	180.94	7.60	174.09	6.62
Weight (kg)	78.75	10.29	72.16	10.59

TABLE 5

Female Anthropometric Dimensions. Means and Standard Deviations of Sample and (Comparison) Population Data

<i>Anthropometric Dimension</i>	<i>Subject</i>		<i>Military</i>	
	<i>Mean</i>	<i>Std Dev</i>	<i>Mean</i>	<i>Std Dev</i>
Forearm Length (FL) (cm)	25.56	1.49	25.24	2.08
Distal Forearm Circumference (FCD) (cm)	20.30	1.69	---	---
Proximal Forearm Circumference (FCP) (cm)	23.50	1.39	24.77	2.13
Wrist Breadth (WB) (cm)	5.02	0.28	5.03	0.27
Wrist Thickness (WT) (cm)	3.36	0.18	---	---
Wrist Circumference (WC) (cm)	14.88	0.78	15.27	0.97
Hand Breadth (HB) (cm)	7.61	0.38	7.66	0.49
Hand Length (HL) (cm)	17.44	0.84	17.17	0.86
Stature (cm)	166.50	6.43	160.43	6.32
Weight (kg)	61.25	8.05	60.55	11.78

TABLE 6

Results of Tests of Differences Between Means and Homogeneity of Variance for Sample and Comparison Data. Significance at the  $\alpha \leq 0.05$  Level is Denoted by \*

<i>Anthropometric Dimension</i>	<i>P(Difference between means)</i>		<i>P(Heteroscedasticity)</i>	
	<i>Male</i>	<i>Female</i>	<i>Male</i>	<i>Female</i>
FL	0.9926	0.8003	0.8372	0.8636
FCD	0.8164	0.0006*	0.4845	0.9205
WB	0.9941*	0.3960	0.6438	0.3905
WC	0.3259	0.0138*	0.6397	0.7551
HB	0.0215*	0.2997	0.3719	0.7905
HL	0.0335	0.9584	0.2202	0.5061
Stature	1.0000*	1.0000*	0.2676	0.4352
Weight	0.9997*	0.6276	0.5084	0.8971

length, male wrist breadth, male stature, and male weight, as shown in Table 6. The means of the sample data were smaller than those of the comparison data for female proximal forearm circumference, female wrist circumference, and male hand breadth. The means of the sample data were larger than those of the comparison data for male wrist breadth, male stature, male weight, and female stature. There were no differences in distribution variance for each anthropometric dimension between the (subject) sample and (military) population.

To determine whether there was a significant gender difference between each of the anthropometric dimensions recorded on the subject sample, critical ratio tests were performed using SAS. All average male dimensions were found to be significantly greater than each corresponding female dimension ( $p \leq 0.0001$ ).

#### Correlations between Measured Variables

The review of the literature demonstrated that there has been a prevalent theory which states that ROM (Brumfield et al., 1966; Dempster, 1960; Staff, 1983; Woodson, 1981) and force generation (An et al., 1986; Chaffin and Andersson, 1984; Kroemer et al., 1986; Sanders and McCormick, 1986) are gender linked. Individual capacities, in terms of anthropometric dimensions and physical capacity (such as strength or endurance), are commonly examined in the literature. For example, Jiang, Smith, and Ayoub (1986) employed 26 anthropometric dimensions and several physical capacity measures to predict manual material handling (MMH) capacities. They found that the anthropometric dimensions were neither correlated with MMH capacities nor predictive of them. Other authors (An et al., 1986; Brumfield et al., 1966; Dempster, 1960; Staff, 1983; Woodson, 1981) who have hypothesized that ROM and force generation may be a function of anthropometric dimensions have not analyzed statistical correlation between these variables. Many of the anthropometric dimensions are correlated between one another, as well as gender linked (NASA, 1978). The degree of linear relation among variables such as ROM, MVC force generated, and discrete anthropometric dimensions can be demonstrated by the product-moment correlation.

To examine all possible linear relationships between pairs of measured variables, a matrix containing all pairs of coefficients of correlation was generated for each gender. These variables include forearm length, distal forearm circumference, proximal forearm circumference, wrist breadth, wrist thickness, wrist circumference, hand length, hand breadth, range of motion (ROM), and force (mean for both flexion and extension). The correlation matrix for males is shown in Table 7 and for females in Table 8.

Acceptance of a linear association between two variables is based upon the value of the correlation coefficient. In anthropometry, the lowest acceptable correlation coefficient is 0.7 (Kroemer et al., 1986). For 30 subjects, a correlation of 0.7 is significant at  $\alpha = 0.0005$ .

The pairs of variables demonstrating an acceptable linear relationship for males are forearm length and hand breadth, distal and proximal forearm circumference, distal forearm circumference and wrist circumference, proximal forearm circumference and wrist circumference, wrist breadth and wrist circumference, and wrist thickness and wrist circumference. The acceptably related pairs of variables for females are distal and proximal forearm circumference, distal forearm circumference and wrist thickness, distal forearm circumference and wrist circumference, proximal forearm circumference and wrist thickness, proximal forearm circumference and wrist circumference, and wrist breadth and wrist circumference. It is interesting to note that, as in the study by Jiang et al. (1986), no correlation was found between anthropometric dimensions and MVC force generation.

#### Range of Motion

The mean ROM was 151.8 deg with a standard deviation of 27.24 deg for males, and 164.0 deg with a standard deviation of 13.48 deg for females. Females had a significantly larger ROM than males ( $Z = 2.193$ ,  $p = 0.0142$ ).

The mean ROM for all subjects was 157.9 deg. This experimental result was compared to the ROM reported in the literature. The critical ratio test was performed between each total ROM in the literature and the mean ROM from this study. These

TABLE 7

Product-Moment Correlations Between Variables for Male Subjects.  
Correlations of 0.7 or Greater are Denoted by \*

	<i>FL</i>	<i>FCD</i>	<i>FCP</i>	<i>WB</i>	<i>WT</i>	<i>WC</i>	<i>HL</i>	<i>HB</i>	<i>ROM</i>	<i>FLEX</i>	<i>EXT</i>
<i>FL</i>	----	0.057	0.104	0.403	0.149	0.120	0.514	0.611	0.545	0.164	0.228
<i>FCD</i>	0.057	----	0.817*	0.626	0.769*	0.707*	0.401	0.206	0.223	0.016	0.003
<i>FCP</i>	0.104	0.817*	----	0.528	0.729*	0.723*	0.339	0.089	0.246	0.059	0.017
<i>WB</i>	0.403	0.626	0.528	----	0.565	0.759*	0.606	0.445	0.137	0.024	0.033
<i>WT</i>	0.149	0.769*	0.729*	0.565	----	0.584	0.317	0.130	0.259	0.062	0.078
<i>WC</i>	0.119	0.707*	0.723*	0.759*	0.584	----	0.512	0.404	0.107	0.015	0.016
<i>HL</i>	0.514	0.401	0.339	0.606	0.317	0.512	----	0.662	0.189	0.175	0.199
<i>HB</i>	0.611	0.206	0.089	0.445	0.130	0.404	0.662	----	0.354	0.163	0.129
<i>ROM</i>	0.545	0.223	0.246	0.137	0.259	0.107	0.189	0.354	----	0.199	0.112
<i>FLEX</i>	0.164	0.016	0.059	0.024	0.062	0.015	0.175	0.163	0.199	----	0.473
<i>EXT</i>	0.228	0.003	0.017	0.033	0.078	0.016	0.199	0.129	0.112	0.473	----

TABLE 8

Product-Moment Correlations Between Variables for Female Subjects.  
Correlations of 0.7 or Greater are Denoted by \*

	<i>FL</i>	<i>FCD</i>	<i>FCP</i>	<i>WB</i>	<i>WT</i>	<i>WC</i>	<i>HL</i>	<i>HB</i>	<i>ROM</i>	<i>FLEX</i>	<i>EXT</i>
<i>FL</i>	----	0.339	0.249	0.405	0.233	0.372	0.601	0.798*	0.003	0.346	0.374
<i>FCD</i>	0.339	----	0.816*	0.489	0.576	0.733*	0.514	0.445	0.109	0.077	0.032
<i>FCP</i>	0.249	0.816*	----	0.461	0.625	0.732*	0.496	0.459	0.254	0.043	0.049
<i>WB</i>	0.405	0.489	0.461	----	0.578	0.767*	0.627	0.534	0.058	0.122	0.214
<i>WT</i>	0.233	0.576	0.625	0.578	----	0.759*	0.529	0.389	0.052	0.027	0.088
<i>WC</i>	0.372	0.733*	0.732*	0.767*	0.759*	----	0.681	0.600	0.246	0.006	0.107
<i>HL</i>	0.610	0.514	0.497	0.627	0.529	0.681	----	0.803*	0.129	0.203	0.396
<i>HB</i>	0.798*	0.445	0.459	0.534	0.389	0.600	0.803*	----	0.238	0.293	0.396
<i>ROM</i>	0.003	0.109	0.254	0.058	0.052	0.246	0.129	0.239	----	0.113	0.171
<i>FLEX</i>	0.346	0.077	0.043	0.122	0.028	0.006	0.203	0.293	0.113	----	0.681
<i>EXT</i>	0.374	0.033	0.049	0.214	0.088	0.107	0.299	0.396	0.171	0.681	----

results are shown in Table 9; as indicated, no significant difference was found for data of Brumfield (1966), Norkin and Levangie (1983), and Rowe (1985).

Prediction of the ROM based upon any or all of the anthropometric dimensions, age and/or gender for "normal" wrists would aid in the estimation of functional decrease due to aging or injury, since baseline ROM values are not usually available. Based upon the correlation matrices, shown in Table 7 for males and Table 8 for females, no anthropometric dimensions were linearly related to ROM with a correlation coefficient greater than 0.7.

Prediction models for ROM were generated (by gender and overall) for all the anthropometric dimensions recorded (forearm length, proximal forearm circumference, distal forearm circumference, wrist breadth, wrist thickness, wrist circumference, hand breadth, and hand length) utilizing PRESSALL. PRESSALL is a SAS MACRO program, developed by the Virginia Polytechnic Institute and State University statistics department, which ranks all possible models based upon the  $R^2$ ,  $C_p$ , and PRESS statistics. The PRESSALL procedure withholds the first predictive data point set from the sample, using the remaining observations to estimate the parameters for the candidate models. The first datum is then replaced in the sample and, in the next iteration, the second data point set is withheld and parameter coefficients re-estimated. Each subsequent iteration removes one data point set at a time, until all possible candidate models are fit with all the predictive data points (Myers, 1986).

Validation is required to evaluate the performance of the predictive model. This has traditionally been done by data splitting, which requires a sample size twice the number needed to generalize the results. The PRESSALL procedure performs data splitting as a form of validation without wasting any of the data collected, since they are added back into the sample (Myers, 1986).

The "best" models for each ROM data set are shown in Table 10. Preliminary selection of the candidate models would have been done using the PRESS and  $C_p$  statistical values, as given by the PRESSALL algorithm, if the  $R^2$  values had been above



TABLE 9

Total Range of Motion, Critical Ratio, and Associated Probability.

\* Denotes Significant Difference to the Present Study

<i>Author(s)</i>	<i>ROM</i>	<i>Z</i>	<i>p</i>
Brumfield, Nickel, and Nickel (1966)	154 deg	-1.0531	0.1462
American Assoc. of Orthopaedic Surgeons, as cited by Brumfield et al. (1966); Cailliet (1977)	150 deg	-2.12902	0.0166*
Ruby et al. (1988)	112 deg	-12.3505	0.0001*
Kelley (1971)	170 deg	3.2507	0.9999*
Norkin and Levangie (1983)	155-165 deg	-0.78 - 1.91	0.217 - 0.972
Bunnell (1948)	130-150 deg	-7.51 - -2.13	0.0001 - 0.017*
Rowe (1985)	120-180 deg	-10.2 - 5.9	0.0001 - 0.999
Woodson (1981)	189 deg	8.3614	0.9999*
Hazelton, Smidt, Flatt and Stephens (1975)	125 deg	-8.5367	0.9999*
Bradley and Sunderland (1953)	131 deg	-7.2398	0.0001*

TABLE 10

Best Candidate Models Generated Using the PRESSALL Algorithm

<i>Data Set</i>	$R^2$	<i>"Best" Regression Equation Predicting ROM (In Degrees)</i>
<i>Male</i>	0.388	ROM = 11.6 + 5.9FL - 2.5FCD + 26.3WB - 21.2WT - 4.7WC + 4.5HL - 5.9HB
<i>Female</i>	0.361	ROM = 116 - 2.8FL + 3.6FCP - 11.7WB - 43.4WT + 13.2WC + 7.5HL - 4.3HB
<i>Total</i>	0.259	ROM = 171.7 + 1.1FL - 1.8FCD + 1.0FCP + 6.9WB - 41.6WT + 0.6WC + 5.8HL - 3.8HB

0.5. This was, however, not the case for male, female, or combined data. Further examination of these statistics would have permitted selection of a "best model" from all the candidate models.

The regression equation residuals were examined for trends which might have required nonlinear transformation of the data before subsequent regressions were performed. There was no discernable trend in the residuals for the linear models, nor for the higher order models.

The only conclusion that can be drawn from these calculations is that, for this subject sample, no prediction model of the ROM based upon the anthropometric dimensions of the subjects can be generated which explains at least 50 percent of the variance in the data.

An analysis of variance procedure was performed with ROM as the dependent variable and the anthropometric dimensions as independent variables. Because the measures of forearm length, distal forearm circumference, proximal forearm circumference, wrist breadth, wrist thickness, wrist circumference, hand length, and hand breadth were continuously distributed, the independent variables were dichotomized into categories of above or below the mean for each dimension. Due to limited data, only main effects and second-order interactions were tested. Effects due to the subjects within gender and the interactions between anthropometric dimensions and the main subject effect were omitted since each of these factors would require 58 degrees-of-freedom, while the total degrees-of-freedom only number 60. The ANOVA summary table is shown in Table 11, showing significance only for the main effect of gender. While gender was found to be significant in the ANOVA, this does not indicate that these differences are correlated with nor are they predictive of ROM. In fact, the results of the correlation and PRESSALL procedures indicate that they are not.

#### Center of Rotation

The ICOR points were examined to determine whether the ICOR points for each experimental condition (load) fall within a small enough grouping that the joint may be

TABLE 11

ROM ANOVA Summary Table

<i>Source</i>	<i>df</i>	<i>MS</i>	<i>F</i>	<i>p</i>
Gender (G)	1	3652.1	5.11	0.025
Forearm Length (FL)	1	1983.7	2.78	0.118
Distal Forearm Circ (FCD)	1	183.7	0.26	0.620
Proximal Forearm Circ (FCP)	1	0.4	0.0001	0.981
Wrist Breadth (WB)	1	350.4	0.49	0.495
Wrist Thickness (WT)	1	33.7	0.05	0.831
Wrist Circumference (WC)	1	120.4	0.17	0.688
Hand Breadth (HB)	1	350.4	0.49	0.495
Hand Length (HL)	1	1353.7	1.89	0.190
FL x G	1	2220.4	3.11	0.100
FL x FCD	1	163.1	1.07	0.319
FL x FCP	1	72.2	0.10	0.755
FL x WB	1	194.3	0.27	0.610
FL x WT	1	341.3	0.48	0.501
FL x WC	1	372.5	0.52	0.482
FL x HB	1	0.001	0.0001	0.999
FL x HL	1	0.001	0.0001	0.999
FCD x G	1	260.4	0.36	0.556
FCD x FCP	1	322.4	0.45	0.513
FCD x WB	1	372.0	0.52	0.483
FCD x WT	1	0.001	0.0001	0.999
FCD x WC	1	277.9	0.39	0.543
FCD x HB	1	143.6	0.20	0.661
FCD x HL	1	481.9	0.67	0.425
FCP x G	1	303.7	0.43	0.525
FCP x WB	1	170.7	0.24	0.633
FCP x WT	1	200.9	0.28	0.604
FCP x WC	1	121.3	0.17	0.687
FCP x HB	1	16.5	0.02	0.881
FCP x HL	1	53.5	0.07	0.788
WB x G	1	1353.7	1.89	0.190
WB x WT	1	423.6	0.59	0.454
WB x WC	1	416.2	0.58	0.458
WB x HB	1	990.7	1.39	0.259
WB x HL	1	0.001	0.0001	0.999
WT x G	1	10.4	0.01	0.906
WT x WC	1	0.001	0.0001	0.999
WT x HB	1	532.9	0.75	0.402
WT x HL	1	480.2	0.67	0.426
WC x G	1	1000.4	1.40	0.257
WC x HB	1	376.4	0.53	0.480
WC x HL	1	650.4	0.91	0.356
HB x G	1	33.7	0.05	0.831
HB x HL	1	0.001	0.0001	0.999
HL x G	1	70.4	0.10	0.758
Pooled Error	14	714.7		
Total	59			

considered a simple hinge joint in flexion and extension when compared to the hypothetical COR (in the head or neck of the capitae). Comparisons were made of the variances of the load conditions, and the means and variances of each variable and combination of variables were examined.

Since there was no prior knowledge about the effect of the load condition upon the variance of radial COR distances, a test for homogeneity of variance for the radial distance from the hypothetical COR among the three load conditions over the wrist positions was performed. This was done using the Hartley  $F_{MAX}$  statistic (Winer, 1971), which resulted in a calculated  $F_{MAX}$  value of 15.35 ( $p < 0.01$ ). This large difference in the variances caused the subsequent ANOVAs on these data to be conservative.

An ANOVA procedure was used to evaluate the radial distance of the ICOR from the hypothesized COR (within the capitae), as shown in Table 12. The only significant effect is wrist position. Post hoc testing was performed on wrist position with the least-significant difference test, as shown in Table 13.

The least significant difference test shows that there is a symmetry for the ICOR points, meaning that equivalent displacements yield statistically similar results. The extreme angles (45-deg flexion and extension) were not significantly different from one another in the post hoc test, but had a significantly smaller mean radial distance from the hypothesized COR. Similarly, the set of symmetrical angles with the next smallest mean radial distance for the hypothesized COR (30-deg flexion and 30-deg extension) were also not significantly different from one another. The symmetric angle set 15-deg flexion and extension were not significantly different from one another, but had a larger mean radial distance than the other symmetric angle sets. However, the mean radial distance of 15-deg flexion and 30-deg extension were not significantly different. The neutral (0-deg) position had the largest mean radial distance. This position had a significantly larger mean radial distance from the hypothesized COR than all the other wrist positions.

TABLE 12

ICOR ANOVA Summary Table

<i>Source</i>	<i>df</i>	<i>MS</i>	<i>F</i>	<i>p</i>
<i>Between Subject</i>				
Gender (G)	1	68515.8	1.05	0.3102
Subjects S/G	58	6537.55		
<i>Within Subject</i>				
Wrist Position (W)	6	771853.55	18.83	0.0001
W x G	6	59957.18	1.46	0.1900
W x S/G	348	40980.04		
Direction (D)	1	121313.9	2.35	0.1305
D x G	1	105.6	0.0001	0.9640
D x S/G	58	51563.29		
Load (L)	2	49575.3	0.71	0.4929
L x G	2	8553.10	0.12	0.8846
L x S/G	116	69649.50		
W x D	6	17858.2	0.41	0.8753
W x D x G	6	32337.72	0.73	0.6223
W x D x S/G	348	44044.03		
W x L	12	43308.93	1.00	0.4487
W x L x G	12	42891.80	0.99	0.4580
W x L x S/G	696	43385.89		
D x L	2	104949.05	1.79	0.1717
D x L x G	2	6622.70	0.11	0.8934
D x L x S/G	116	58668.76		
W x D x L	12	24471.74	0.57	0.8700
W x D x L x G	12	43620.18	1.01	0.4383
W x D x L x S/G	696	43224.68		
Total	2519			

TABLE 13

ICOR Least Significant Difference T-test for Wrist Position. Vertical Lines Indicate that there is not a Significant ( $p \leq .05$ ) Difference Between Means

<i>Wrist Angle</i>	<i>Mean Radial Distance (cm)</i>	<i>Grouping</i>
0-deg Neutral	13.33	
15-deg Extension	9.58	
15-deg Flexion	7.48	
30-deg Extension	5.62	
30-deg Flexion	4.31	
45-deg Extension	0.84	
45-deg Flexion	0.53	

### Force Generation

The mean flexion force generated by the wrist-dedicated (carpi) muscles was 72.37 N for males and 55.24 N for females. The mean extension force was calculated to be 61.96 N for males and 44.86 N for females. The means for both flexion force generation ( $Z = 4.003$ ,  $p = 0.0001$ ) and extension ( $Z = 4.585$ ,  $p = 0.0001$ ) indicate that these forces are gender dependent.

Comparisons between mean flexion and extension forces, between peak and average flexion forces, and between peak and average extension forces (by gender) were performed. The average extension force was found to be significantly different from the average flexion force for both males and females (Table 14). There was no significant difference between the mean and peak force for both flexion and extension. Therefore, only the average forces generated in flexion and extension were analyzed further. This result also signifies that the exertion can be considered a static exertion, where the average force is not significantly different from the peak.

The PRESSALL algorithm was employed to evaluate all possible flexion and extension force prediction models, based upon any or all of the following variables: forearm length, distal and proximal forearm circumference, wrist breadth, wrist thickness, wrist circumference, hand length, hand breadth, ROM, and wrist position. None of the linear models yielded an  $R^2$  of 0.4 or greater; therefore, these predictor variable values were squared and reanalyzed employing the PRESSALL procedure. These models were equally inadequate predictors of the average flexion and extension forces. The best regression models (Table 15) for the average flexion and extension forces by gender were run on SAS, and the residuals were plotted. These plots showed no trends to indicate further refinements which could improve the models. Flexion and extension forces were also hypothesized to be a function of wrist position alone, so four regression models (one for each force exertion direction and gender combination) with wrist position as the sole predictor were calculated. All of these models had an  $R^2$  value of less than 0.2. Thus, the conclusion was drawn that the flexion and extension forces



TABLE 14

Force Comparisons Using the Critical Ratio Test

<i>Force Exertion</i>	<i>Male</i>		<i>Female</i>	
	<i>Z</i>	<i>p</i>	<i>Z</i>	<i>p</i>
<i>Flexion - Average vs. Peak</i>	1.052	0.146	0.915	0.181
<i>Extension - Average vs. Peak</i>	0.868	0.193	0.997	0.159
<i>Average - Extension vs. Flexion</i>	2.486	0.006	2.709	0.003

TABLE 15

Best Candidate Models Generated Using the PRESSALL Algorithm

<i>Data Set</i>	$R^2$	<i>"Best" Regression Equation Predicting Average Force (N)</i>
Male	0.295	FLEXION = -41.1 - 1.5FCD + 3.2FCP - 8.1WB + 13.0WT -2.1WC + 0.5ROM + 36.2WP
Male	0.137	FLEXION = 94.5 - 0.2WP
Male	0.038	EXTENSION = 23.9 - 1.5FCP - 4.4WB + 21.2WT + 0.1ROM + 2.5WP
Male	0.013	EXTENSION = 66.3 + 0.02WP
Female	0.224	FLEXION = -12.9 - 1.3FCD + 24.6WB - 5.8WC + 0.3ROM + 0.2WP
Female	0.178	FLEXION = 71.5 - 0.2WP
Female	0.114	EXTENSION = -47.7 - 1.8FCD + 0.9FCP + 20.1WB + 11.5WT - 4.9WC + 0.3ROM
Female	0.046	EXTENSION = 48.3 - 0.01WP
Total	0.327	FLEXION = -99.7 - 2.8FCD + 3.6FCP + 19.6WB + 10.0WT -4.9WC + 0.33ROM + 32.5WP
Total	0.149	FLEXION = 83.4 - 0.2WP
Total	0.201	EXTENSION = -68.0 - 2.4FCD + 1.0FCP + 12.5WB + 17.4WT + -0.1ROM
Total	0.031	EXTENSION = 53.6 - 0.02WP

for both genders cannot be modeled effectively with a regression equation for the subject sample using the anthropometric data collected in this study.

To evaluate all possible effects of gender, direction of force exertion (flexion and extension), and wrist position (13 levels, between 90-deg flexion and 90-deg extension) on the average force that was generated, an ANOVA procedure was performed. Since the number of wrist position tested is a function of individual ROM, there are unequal cell sizes in the extreme wrist positions. This reduces the total degrees-of-freedom from 1559 to the actual number of force observations. The ANOVA summary table (Table 16) shows that gender, direction, wrist position, and the interaction of wrist position and direction effects were statistically significant.

Post hoc testing was performed on wrist position and the least significant difference test results are shown in Table 17. Mean forces at wrist positions joined by vertical lines do not differ significantly at  $\alpha = 0.05$ . At the 90-deg flexion position, extreme flexion, the average force generated by the wrist-dedicated muscles was the highest. This force was significantly higher than the force at 75-deg flexion which was, in turn, higher than 30-deg flexion forces. The forces at 30-deg flexion, 45-deg flexion, 15-deg extension, and 15-deg flexion were not significantly different from one another. However, the 30-deg flexion force was significantly higher than the grouping of 45-deg flexion, 15-deg extension, 15-deg flexion, and 30-deg extension. Similarly, the average force at 45-deg flexion was significantly higher than the grouping of 15-deg extension, 15-deg flexion, 30-deg extension, 90-deg extension, and neutral (0-deg). All the average forces in the above wrist positions were significantly higher than those at 60-deg flexion and 45-deg extension. The forces calculated to be significantly lower than all the others were 60-deg extension and 75-deg extension. These last two wrist positions were not significantly different.

To examine the effect of direction at each wrist position, simple-effects F-tests were performed. The gender-by-direction ANOVA summary tables were calculated for each of the 13 wrist positions; these can be found in Tables 23 - 35 (Appendix F). The

TABLE 16

## Force ANOVA Summary Table

<i>Source</i>	<i>df</i>	<i>MS</i>	<i>F</i>	<i>p</i>
<i>Between Subject</i>				
Gender (G)	1	103984.9	21.42	0.0001
Subjects (S/G)	58	4853.7		
<i>Within Subject</i>				
Wrist Position (WP)	12	5675.8	35.06	0.0001
W x G	12	98.9	0.61	0.8339
W x S/G	597	161.9		
Exertion Direction (D)	1	38689.3	59.52	0.0001
D x G	1	30.9	0.05	0.8279
D x S/G	58	650.0		
WP x D	12	3457.6	38.56	0.0001
WP x D x G	12	122.7	1.37	0.1764
WP x D x S/G	597	89.7		
Total	1361			

TABLE 17

Force Least Significant Difference T-Test for Wrist Position.  
 Vertical Lines Indicate that there is not a Significant ( $p \leq .05$ )  
 Difference Between Means

<i>Wrist Position</i>	<i>Mean Force (N)</i>	<i>Grouping</i>
90-deg Flexion	76.92	
75-deg Flexion	70.07	
30-deg Flexion	64.67	
45-deg Flexion	63.12	
15-deg Extension	62.07	
15-deg Flexion	60.88	
30-deg Extension	60.37	
90-deg Extension	59.21	
0-deg Neutral	58.80	
60-deg Flexion	56.62	
45-deg Extension	54.17	
60-deg Extension	47.08	
75-deg Extension	44.95	

ANOVA results have been further summarized by tabulating the average flexion force, extension force, and the probabilities associated with each F-value for force exertion direction at each wrist position (Table 18). At each wrist position a significant difference was shown between average flexion and extension forces. In all but the two extreme extension wrist positions, flexion force was greater than extension force.

The mean forces at each wrist position (categorized by gender, Table 19) were calculated and plotted for flexion and extension. These values were then plotted separately for males and female, with Figures 15 and 16 for flexion and extension, respectively. A distinct pattern over the range of wrist positions is seen. The pattern for flexion differs from that of extension; yet the male (●) and female (\*) data form the same pattern, which may account for the non-significant gender by position interaction.

TABLE 18

Mean Flexion and Extension Forces (N) and Simple Effect F-test Probabilities by Wrist Position

<i>Wrist Position</i>	<i>Flexion Force</i>	<i>Extension Force</i>	<i>p</i>
90-deg Flexion	93.69	60.16	0.0061
75-deg Flexion	88.71	51.43	0.0001
60-deg Flexion	67.18	46.06	0.0001
45-deg Flexion	70.68	55.56	0.0001
30-deg Flexion	72.11	57.22	0.0001
15-deg Flexion	66.76	55.00	0.0001
0-deg Neutral	63.33	54.28	0.0001
15-deg Flexion	66.52	57.62	0.0001
30-deg Flexion	63.13	57.68	0.0055
45-deg Flexion	57.08	51.39	0.0003
60-deg Flexion	49.70	44.46	0.0001
75-deg Flexion	43.02	46.88	0.0014
90-deg Flexion	52.37	66.06	0.0001

TABLE 19

Average Force (in N) for Each Wrist Position. Categorized by Gender and Direction of Force

<i>Wrist Position</i>	<i>Male Force (N)</i>		<i>Female Force (N)</i>	
	<i>Flexion</i>	<i>Extension</i>	<i>Flexion</i>	<i>Extension</i>
90-deg Flexion	60.55	76.87	47.05	59.05
75-deg Flexion	47.54	54.29	39.11	40.46
60-deg Flexion	57.08	52.24	43.06	37.46
45-deg Flexion	65.59	60.18	48.28	42.31
30-deg Flexion	72.56	68.72	54.01	47.01
15-deg Flexion	74.78	68.35	58.25	46.90
0-deg Neutral	73.12	63.16	53.53	45.40
15-deg Flexion	76.36	64.44	57.15	45.56
30-deg Flexion	81.06	66.76	63.16	47.68
45-deg Flexion	81.60	64.62	59.76	46.49
60-deg Flexion	76.99	51.79	58.05	40.71
75-deg Flexion	101.05	58.86	79.88	46.12
90-deg Flexion	104.24	68.27	75.23	45.48



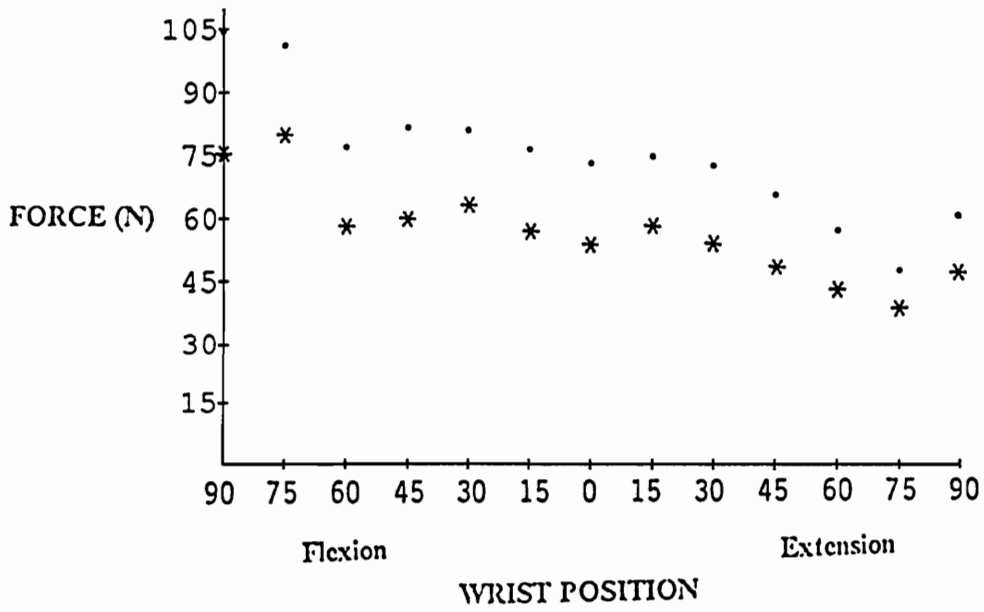

Figure 15. Flexion force (N) versus wrist position. Male data points denoted by (•) and female data denoted by (\*).

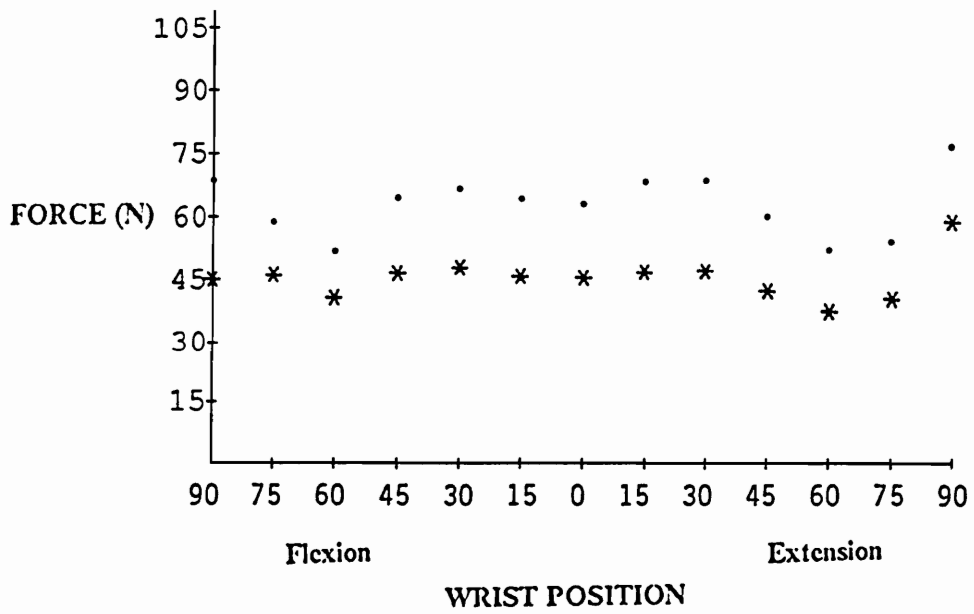

Figure 16. Extension force (N) versus wrist position. Male data points denoted by (•) and female data denoted by (\*).

## DISCUSSION AND CONCLUSIONS

### Anthropometric Dimensions

The data from the 60 subjects are found to be statistically similar to the enlisted military (comparison) population for most anthropometric dimensions. The dimensions that are significantly different between the military and female subject samples are wrist breadth, wrist circumference, stature, and weight. The mean proximal forearm circumference and wrist circumference dimensions were taken from a 1940 female population, and secular changes over the intervening 50 years could have contributed to the differences between samples for these dimensions. The mean stature for the females in this study is significantly greater than that of the comparison population. This may be due to secular anthropometric changes or the somewhat select sample of college-attending females.

The male population data has significant differences between the population and sample means for wrist breadth, hand breadth, stature, and weight. The military population was sampled in 1965, so no large secular changes were expected. The differences between the means are not reflected in the comparison of variances for males nor females. All of the anthropometric dimensions are deemed homogeneous in variance. Gender differences for each anthropometric dimension were analyzed and significant gender differences found for every dimension measured in this study, as would be expected.

### Range of Motion

Brumfield et al. (1966) stated that ROM varies among individuals and may be a function of gender and physical build. The average ROM for females in this study is 164 deg; significantly greater than the average male ROM (151.83 deg). The low correlation coefficients between ROM and each anthropometric dimension and the low  $R^2$  of the regression equations tend to refute the theories of Brumfield et al. (1966). The data analyses for the subject sample show that the ROM is not a function of physical (anthropometric) dimensions.

### Center of Rotation

The ANOVA for the ICOR data isolated only one significant main effect, that of wrist angle. Rejection of the null hypotheses in the  $F_{MAX}$  tests demonstrated that the ICOR data, as measured by the Method of Reuleaux, caused the ANOVA analyses to be conservative. A post hoc test performed on the wrist angle demonstrates a symmetry not previously postulated nor expected. The 15-deg extension is not significantly different from 15-deg flexion, and 30-deg extension is not significantly different from 30-deg flexion, etc., in terms of radial distance from the hypothetical COR. It also shows that the mean radial distance between the measured and hypothesized ICOR decreases as the wrist position is displaced from the neutral (0-deg) position. Thus, in general, as the wrist moves out of neutral, the mean radial distance decreases as the flexion or extension angles increase and this decrease is symmetric about the neutral position.

The Method of Reuleaux, reported as successful by Dempster (1955, 1960), was difficult to administer with accuracy in this study. The recorded arcs were not always smooth, symmetric, and reproducible. The accuracy problems associated with the employment of this method may have been partly due to handle slippage. The handle was difficult to keep in place on the palm, even though the handle compressed the tissue to the extent of bloodflow disruption. In addition, the exact placement of the theoretical center of rotation was difficult to establish and place in the apparatus with accuracy. Thus, the recorded arcs upon which the Method of Reuleaux relied may have had some degree of error. Assuming the arcs were drawn and the x and y coordinates obtained correctly, the calculations using this information were reliable; since each intersection of the perpendicular bisectors (ICOR) was calculated by the computer program shown in Appendix D.

The dual articular system has two joints, each of which change shape through the range of motion. As these bones and joints shift with respect to one another, the tendons and ligaments in contact with these surfaces are displaced. When joint motion begins at the neutral position, flexion and extension are initiated at different joints.

Flexion begins by rotation within the RC joint, while extension is initiated in the MC joint. As the wrist moves farther from neutral, both the RC and MC joints play a role in the rotation. However, even at the extreme ROM, the contributions of the two joints to the end position are not considered equal for flexion and extension. Many authors (Bunnell, 1948; Cailliet, 1971; Cunningham, 1953; Fick 1911, as cited by Ketchum et al., 1978; Kapandji, 1968, 1987; Kaplan, 1965; Sarrafian, 1977; Volz, 1976; Von Lanz and Wachsmith, 1959) feel that the RC joint contributes more than the MC joint to overall flexion. Extension is believed to be just the opposite, with MC joint contribution greater than that of the RC (Cailliet, 1971; Fick, 1911, as cited by Ketchum et al, 1978; Horwitz, 1940; Kapandji, 1968, 1987; Kaplan, 1965; Sarrafian et al., 1977; Volz, 1976; Von Lanz and Wachsmith, 1959). The COR should be affected by the shifting of bones and changes in contribution by each carpal joint over the ROM. Thus, one would not expect a single COR for the dual articulation system. The ANOVA results show significant differences among ICOR locations over the range of motion. The post hoc testing demonstrates that the mean radial distance between the ICOR located by the Method of Reuleaux and the hypothesized COR is symmetrical about the neutral wrist position. This finding lends credence to the belief that the RC and MC joints contribute an equal (or symmetrical) amount for flexion and extension.

The anatomical and physiological literature does not indicate whether direction of motion makes a difference in the bone and joint configuration and function. Direction of motion, from neutral to the extreme end points of motion, or from the extreme positions back to neutral, may affect the COR if the bone and joint configuration is not symmetrical. Direction of motion was not found to be a significant effect in the ANOVA. This result reaffirms the wrist position symmetry found in the post hoc testing for mean radial distance. However, some subjects' raw data showed differences between the full extension to full flexion and the reverse (full flexion to full extension) arc. This difference between arcs was fairly consistent for each subject, but the magnitude of the difference of the arc location for several subjects was greater than

would be expected for a bone and joint configuration change. These arc displacements may have been due to mechanism error or arm skin displacement over the muscle and bone substructure.

### Force Generation

Analyses of active force generation demonstrates that no adequate predictive model for maximal force exertion could be generated using any (or all) of the eight anthropometric dimensions, ROM, and wrist position.

The means of average and peak forces were not found significantly different for males or for females. This was probably an artifact of the static testing procedure. The static force measure was rejected if there was a single peak point outside of a  $\pm 10$  percent band around the mean for that exertion. Since the peak and average forces were not significantly different, these forces could be termed a static exertion. Thus, one of the underlying assumptions in this study was confirmed to be statistically true.

The ANOVA procedure demonstrates that the main effects of gender, wrist position, and force exertion direction are significant as is the wrist position interaction with direction. Based upon the literature, these results were expected.

It has been stated that female strength is significantly lower than that of males. Female forces range between half to two-thirds that which can be generated by males (An et al., 1986; Roebuck et al., 1975; Sanders and McCormick, 1986). The average forces measured in this study are significantly different for males and females. The female forces generated in this study are 76.3 percent and 72.4 percent of that generated by males in flexion and extension, respectively. The subject selection may have influenced these results, as well as the subjects' age (20 to 30 years of age) and physical condition (self-reported as good to excellent).

Prior research (Anderson 1965; Hazelton et al., 1975; Kraft and Detels, 1972; Linscheid and Chao, 1973; Mathiowetz et al., 1985; Pryce, 1980; Skovly, 1967; Woody and Mathiowetz, 1988) shows the effect of joint angle upon MVC force for grip and pinch. Thus, significance of wrist position for force generation was expected. As each

joint position changes, each bone comprising that joint shifts with respect to others, displacing all tendons and ligaments in contact with the bone (Weber, 1988). Thus, the wrist position may affect the magnitude of forces that can be generated in the carpus by changing the tendon length and moment arms of the bony configuration. In general, average forces in flexion wrist positions are significantly higher than those of wrist extension. However, there are some reversals and the neutral (0-deg) position is below the mid-point of force exertion magnitudes.

The direction of the force was also expected to be a significant factor in the force generation magnitude. Flexion forces were hypothesized to be greater than those of extension, since the distal upper limb contains more flexors than extensors and they are more powerful (Thompson, 1981). An et al. (1986), Brand (1985), Brand et al. (1981), Ketchum et al. (1978), and Norkin and Levangie (1983) found that flexion forces were twice those generated in extension. These flexion and extension force values were for hand strength, a combination of wrist and digital muscles. The wrist muscles, alone, may be more balanced than those of the hand. There are three wrist-dedicated flexors and three extensor muscles, and while the flexors have a larger physiological cross-sectional area, it is not twice the area of the extensors (Brand, 1985). This study shows a smaller difference between flexion and extension forces than those in previous studies. On average, extension forces are found to be 85.6 percent of those in flexion for males and 81.2 percent for females.

### Recommendations

A better method needs to be devised to assess the instant center of rotation in the wrist of a live subject in three dimensions. The Method of Reuleaux is theoretically sound, as it is solidly based upon geometry and trigonometry; however, in this study, instrumental arms holding the writing devices which were secured to a flexible palmar surface induced some inaccuracies which could be minimized by employing X-rays and digitizers to gather the raw data for the Method of Reuleaux.

Further studies of both ROM and the forces that can be generated in flexion and extension of the wrist need to be performed employing various populations subsets, with different age ranges and varied health levels. These studies would permit calculation of normative values for ROM and force generation for several different levels of each variable.

The study of forces generated between the hand and forearm segment needs to be expanded to include the entire voluntary musculature of the distal upper limb. These auxiliary studies could permit assessment of the carpi muscle contribution of the flexion and extension forces generated across the wrist.

After these studies are completed, the forces for radial and ulnar deviation, and circumduction need to be evaluated in the same manner. By employing similar techniques for these studies, the data collected could be compared and combined to create a functional biomechanical model of the wrist.



## REFERENCES

- Amis, A.A., Dowson, D., and Wright, V. (1979). Muscle strengths and musculo-skeletal geometry of the upper limb. Engineering in Medicine, 8(1), 41-48.
- An, K.N., Askew, L.J., and Chao, E.Y. (1986). Biomechanics and functional assessment of upper extremities. In W. Karwowski (Ed.), Trends in ergonomics/human factors III (pp. 573-580). North-Holland: Elsevier Science Publishers.
- An, K.N., Chao, E.Y., Cooney, W.P., and Linscheid, R.L. (1983). Tendon excursion and moment arm of index finger muscles. Journal of Biomechanics, 16, 419-425.
- An, K.N., Hui, F.C., Morrey, B.F., Linscheid, R.L., and Chao, E.Y. (1981). Muscles across the elbow joint: A biomechanical analysis. Journal of Biomechanics, 14, 659-669.
- An, K.N., Kaufman, K.R., and Chao, E.Y. (1987). Muscle force through the elbow joint (rev. ed). (Available from Mayo Clinic Biomechanics Laboratory, Rochester, MN 55901).
- An, K.N., Morrey, B.F., and Chao, E.Y. (1985). Kinematics of the elbow. In Winter, Norman, Wells, Hayes, and Patla (Eds.), Biomechanics IX-A (pp. 39-43). Champaign, IL: Kinetics Publishers, Inc.
- Anderson, C.T. (1965). Wrist joint influences normal hand function. Unpublished masters thesis, University of Iowa, Iowa City, IA.
- Andrews, J.G., and Youm, Y. (1979). A biomechanical investigation of wrist kinematics. Journal of Biomechanics, 12, 83-93.
- Armstrong, T.J., and Chaffin, D.B. (1978). An investigation of the relationship between displacement of the finger and wrist joints and the extrinsic finger flexor tendons. Journal of Biomechanics, 11, 119-128.
- Astrand, P.O., and Rodahl, K. (1986). Textbook of work physiology (3rd ed.). New York, NY: McGraw-Hill Book Co.

- Backdahl, M., and Carlsoo, S. (1961). Distribution of activity in muscles acting on the wrist. Acta Morphologia Neerlando-Scandinavica, 4, 136-144.
- Basmajian, J.V., and DeLuca, C.J. (1985). Muscles alive (5th ed.). Baltimore, MD: Williams and Wilkins.
- Berg, V.J., Clay, D.J., Fathallah, F.A., and Higginbotham, V.L. (1988). The effects of instruction on finger strength measurements: Applicability of the Caldwell Regimen. In F. Aghazadeh (Ed.), Trends in ergonomics/human factors V (pp.191-198). North-Holland: Elsevier Science Publishers.
- Berme, N., Paul, J.P., and Purves, W.K. (1977). A biomechanical analysis of the metacarpophalangeal joint. Journal of Biomechanics, 10, 409-412.
- Bogumill, G.P. (1988). Anatomy of the wrist. In D.M. Lichtman (Ed.), The wrist and its disorders (pp.14-26). Philadelphia, PA: W.B. Saunders.
- Bradley, K.C., and Sunderland, S. (1953). The range of movement at the wrist joint. Anatomical Record, 116, 139-145.
- Brand P.W. (1985). Clinical mechanics of the hand. St. Louis, MO: C.V. Mosby Co.
- Brand, P.W., Beach, R.B., and Thompson, D.E. (1981). Relative tension and potential excursion of muscles in the forearm and hand. Journal of Hand Surgery, 6(3), 209-219.
- Brown, D.E., and Lichtman, D.M. (1988). Physical examination of the wrist. In D.M. Lichtman (Ed.), The wrist and its disorders (pp.74-87). Philadelphia, PA: W.B. Saunders.
- Brumfield, R.H., Nickel, V.L., and Nickel, E. (1966). Joint motion in wrist flexion and extension. Southern Medical Journal, 59(3), 909-910.
- Brunnstrom, S. (1972). Clinical kinesiology (3rd ed.). Philadelphia, PA: F.A. Davis, Co.
- Bunnell, S. (1948). Surgery of the hand (2nd ed.). Philadelphia, PA: J.B. Lippincott Co.
- Cailliet, R. (1971). Wrist impairment. New York, NY: McGraw-Hill.

- Caldwell, L.S., Chaffin, D.B., Dukes-Dobos, F.N., Kroemer, K.H.E., Laubach, L.L., Snook, S.H., and Wasserman, D.E. (1974). A proposed standard procedure for static muscle strength testing. American Industrial Hygiene Association Journal, 35(4), 201-206.
- Chaffin, D.B. (1975). Ergonomics guide for the assessment of human static strength. American Industrial Hygiene Journal, 36, 505-511.
- Chaffin, D.B., and Andersson, G. (1984). Occupational biomechanics. New York, NY: Wiley and Sons.
- Chao, E.Y. (1973). Inverse dynamic problem of linkage system and its application in biomechanics. In Y.C. Fung and J.A. Brighton (Eds.), Biomechanics Symposium (pp. 43-45). New York, NY: American Society of Mechanical Engineers.
- Chao, E.Y., and An, K.N. (1978). Determination of internal forces in the human hand. Journal of the Engineering Mechanics Division of ASCE, 104(EM1), 255-272.
- Cooney, W.P., and Chao, E.Y. (1977). Biomechanical analysis of static forces in the thumb during hand function. Journal of Bone and Joint Surgery, 59A(1), 27-36.
- Cunningham, B.E. (1953). Textbook of anatomy (9th ed.). Oxford, England: Oxford University Press.
- de Lange, A., Huiskes, R., and Kauer, J.M.G. (1987). Experimental determination of strains in the carpal ligaments in flexion and deviation of the hand. In Proceedings of the 33rd Annual Meeting (pp. 82). San Francisco, CA: Orthopaedic Research Soc.
- de Lange, A., Kauer, J.M.G., and Huiskes, R. (1985). Kinematic behavior of the human wrist joint: A reontgen-stereophotogrammetric analysis. Journal of Orthopaedic Research, 3(1), 56-64.
- Dempster, W.T. (1955). Space requirements of the seated operator: Geometrical, kinematic, and mechanical aspects of the body with special reference to the limbs (WADC Tech. Report 55-159). Wright-Patterson Air Force Base, OH: Wright Air Development Command, U.S.A.F.

- Hazelton, F.T., Smidt, G.L., Flatt, A.E., and Stephens, R.I. (1975). The influence of wrist position on the force produced by the finger flexors. Journal of Biomechanics, 8, 301-306.
- Hirsch, D., Page, D., Miller, D., Dumbleton, J.H., and Miller, E.H. (1974). A biomechanical analysis of the metacarpophalangeal joint of the thumb. Journal of Biomechanics, 7, 343-348.
- Hollinshead, W.H., and Jenkins, D.B. (1981). Functional anatomy of the limbs and back (5th ed.). Philadelphia, PA: W.B. Saunders.
- Horwitz, T. (1940). An anatomic and roentgenologic study of the wrist joint. Surgery, 3, 773-783.
- Jiang, B.L., Smith, J.L., and Ayoub, M.M. (1986). Psychophysical modeling of manual materials-handling capacities using isoinertial strength variables. Human Factors, 28(6), 691-702.
- Johnston, J. (1907). Varying positions of the carpal bones in the different movements of the wrist. Journal of Anatomy and Physiology, 41(2), 280-291.
- Kapandji, A. (1968). The physiology of the joints: Volume I - upper limb. Edinburgh, Scotland: Churchill Livingstone.
- Kapandji, A. (1987). Biomechanics of the carpus and wrist (in French). Annales De Chirurgie De La Main, 6(2), 147-169.
- Kaplan, E.B., and Smith, R.J. (1984). Kinesiology of the hand and wrist: Chapter 7. In M. Spinner (Ed.), Kaplan's functional and surgical anatomy of the hand (pp. 283-349). Philadelphia, PA: J.B. Lippincott.
- Kaplan, E.B., and Taleisnik, J. (1981). The wrist: Chapter 4. In M. Spinner (Ed.), Kaplan's functional and surgical anatomy of the hand (pp. 153-201). Philadelphia, PA: J.B. Lippincott.
- Kauer, J.M.G. (1974). The interdependence of carpal articulation chains. Acta Anatomica, 88, 481-501.

- Kauer, J.M.G. (1980). Functional anatomy of the wrist. Clinical Orthopedics and Related Research, 149, 9-20.
- Kauer, J.M.G. (1986). The mechanism of the carpal joint. Clinical Orthopedics and Related Research, 202, 16-26.
- Kauer, J.M.G., and de Lange, A. (1987). The carpal joint: Anatomy and function. Hand Clinics, 3(1), 23-30.
- Kauer, J.M.G., and Landsmeer, J.M.F. (1981). Functional anatomy of the wrist: Chapter 11. In R. Tubiana (Ed.), The hand: Volume I (pp. 142-157). Philadelphia, PA: W.B. Saunders.
- Kelley, D.L. (1971). Kinesiology: Fundamentals of motion description. Englewood Cliffs, NJ: Prentice-Hall.
- Ketchum, L.D., Brand, P.W., Thompson, D., and Pocock, G.S. (1978). The determination of moments of extension of the wrist generated by muscles of the forearm. Journal of Hand Surgery, 3(3), 205-210.
- King, A.I. (1984). A review of biomechanical models. Journal of Biomechanical Engineering, 106, 97-104.
- Kraft, G.H., and Detels, P.E. (1972). Position of function of the wrist. Physical Medicine and Rehabilitation, 53, 272-275.
- Kroemer, K.H.E., Kroemer, H.J., and Kroemer-Elbert, K.E. (1986). Engineering physiology. Amsterdam: Elsevier.
- Kroemer, K.H.E., and Marras, W.S. (1981). Evaluation of maximal and submaximal static muscle exertions. Human Factors, 23(6), 643-653.
- Landsmeer, J.M.F. (1960a). Studies in the anatomy of articulation: 1. The equilibrium of the "intercalated bone". Acta Morphologia Neerlando-Scandinavica, 3, 287-303.
- Landsmeer, J.M.F. (1960b). Studies in the anatomy of articulation: 2. Patterns of movement of bi-muscular, bi-articular systems. Acta Morphologia Neerlando-Scandinavica, 3, 304-321.

- Landsmeer, J.M.F. (1961). Power grip and precision handling. Annals of Rheumatic Diseases, 21(2), 164-169.
- Lichtman, D.M., and Martin, R.A. (1988). Introduction to carpal instabilities. In D.M. Lichtman (Ed.), The wrist and its disorders (pp.244-259). Philadelphia, PA: W.B. Saunders.
- Linscheid, R.L. (1986). Kinematic considerations of the wrist. Clinical Orthopedics and Related Research, 202, 27-39.
- Linscheid, R.L., and Chao, E.Y. (1973). Biomechanical assessment of finger function in prosthetic joint design. Orthopaedic Clinics of North America, 4(2), 317-330.
- Linscheid, R.L., Dobyns, J.H., Beabout, J.W., and Bryan, R.S. (1972). Traumatic instability of the wrist. Journal of Bone and Joint Surgery, 54A(8), 1612-1632.
- MacConaill, M.A. (1941). The mechanical anatomy of the carpus and its bearings on some surgical problems. Journal of Anatomy, 75, 166-175.
- MacConaill, M.A., and Basmajian, J.V. (1977). Muscles and movements. New York, NY: Krieger Publishing.
- Mathiowetz, V., Kashman, N., Volland, G., Weber, K., Dowe, M., and Rogers, S. (1985). Grip and pinch strength: Normative data for adults. Archives of Physical Medicine and Rehabilitation, 66, 16-21.
- Mathiowetz, V., Rennells, C., and Donahoe, L. (1985). Effect of elbow position on grip and key pinch strength. Journal of Hand Surgery, 10A(5), 694-697.
- Mathiowetz, V., Weber, K., Volland, G., and Kashman, N. (1984). Reliability and validity of grip and pinch strength evaluations. Journal of Hand Surgery, 9A(2), 222-226.
- Mayfield, J.K. (1988). Pathogenesis of wrist ligament instability. In D.M. Lichtman (Ed.), The wrist and its disorders (pp.53-73). Philadelphia, PA: W.B. Saunders.
- McFarland, G.B., Krusen, U.L., and Weathersby, H.T. (1962). Kinesiology of selected muscles acting on the wrist: Electromyographic study. Archives of Physical Medicine, 43, 165-171.

- McMurtry, R.Y., Youm, Y., Flatt, A.E., and Gillespie, T.E. (1978). Kinematics of the wrist: Clinical applications. Journal of Bone and Joint Surgery, 60A(7), 955-961.
- Morrey, B.F., and Chao, E.Y. (1985). Functional evaluation of the elbow (Ch. 5). In B.F. Morrey (Ed.), The elbow and its disorders (pp.73-91). Philadelphia, PA: Saunders.
- Myers, R.H. (1986). Classical and modern regression with applications. Boston, MA: Duxbury Press.
- NASA (1978). Anthropometric source book. Vol. I: A handbook of anthropometric data (Publ 1024). Washington, D.C.: NASA.
- Neter, J., Wasserman, W., and Kutner, M.H. (1985). Applied linear statistical models (2nd ed.). Homewood, IL: Irwin.
- Norkin, C.C., and Levangie, P.K. (1983). Joint structure and function: A comprehensive analysis. Philadelphia, PA: F.A. Davis.
- Putz-Anderson, V. (1988). Cumulative trauma disorders: A manual for musculoskeletal diseases of the upper limbs. London: Taylor and Francis.
- Pryce, J.C. (1980). The wrist position between neutral and ulnar deviation that facilitates the maximum power grip strength. Journal of Biomechanics, 13, 505-511.
- Radonjic, D., and Long, C. (1971). Kinesiology of the wrist. American Journal of Physical Medicine, 50(2), 57-71.
- Roebuck, J.A., Kroemer, K.H.E., and Thomson, W.G. (1975). Engineering anthropometry methods. New York, NY: Wiley and Sons.
- Rowe, M.L. (1985). Orthopaedic problems at work. New York, NY : Perinton Press.
- Ruby, L.K., Cooney, W.P., An, K.N., Linscheid, R.L., and Chao, E.Y. (1988). Relative motion of selected carpal bones: A kinematic analysis of the normal wrist. Journal of Bone and Joint Surgery, 13A(1), 1-10.
- Sarrafian, S.K., Malamed, J.L., and Goshgarian, G.M. (1977). Study of wrist motion in flexion and extension. Clinical Orthopedics and Related Research, 126, 153-159.
- Skovly, R.C. (1967). A study of power grip strength and how it is influenced by wrist joint position. Unpublished masters thesis, University of Iowa, Iowa City, IA.

- Spoor, C.W., and Landsmeer, J.M.F. (1976). Analysis of the zigzag movement of the human finger under influence of the extensor digitorum and the deep flexor tendon. Journal of Biomechanics, 9, 561-566.
- Stegemann, J. (1981). Exercise physiology. New York, NY: Georg Thieme Verlag.
- Taleisnik, J. (1988). Current concepts review: Carpal instability. Journal of Bone and Joint Surgery, 70A(8), 1262-1268.
- Taylor, C.L., and Schwarz, R.J. (1955). The anatomy and mechanics of the human hand. Artificial Limbs, 2(2), 22-35.
- Tercer, A.F., Viegas, S.F., Chang, M., Hicks, C., and O'Meara, C. (1987). Biomechanical characteristics of the radiocarpal joint. In Proceedings of the 33rd Annual Meeting (pp. 209). San Francisco, CA: Orthopaedic Research Society.
- Toft, R., and Berme, N. (1980). A biomechanical analysis of the joints of the thumb. Journal of Biomechanics, 13, 353-360.
- Tong, J.J., Werner, F.W., and Somerset, J.H. (1986). Wrist joint motion simulator. In Proceedings of the 32nd Annual Meeting (pp. 441). New Orleans, LA: Orthopaedic Research Society.
- Tsumura, H., Himeno, S., An, K.N., Cooney, W.P, and Chao, E.Y.S. (1987). Biomechanical analysis of Kienboeck's disease. In Proceedings of the 33rd Annual Meeting (pp. 208). San Francisco, CA: Orthopaedic Research Society.
- Viegas, S.F., Tencer, A.F, Cantrell, J., Chang, M. Clegg, P, Hicks, C., O'Meara, C., and Williamson, J.B. (1987). Load transfer characteristics of the wrist: The normal joint. Journal of Hand Surgery, 12A(6), 971-977.
- Volz, R.G. (1976). The development of a total wrist arthroplasty. Clinical Orthopedics and Related Research, 116, 209-214.
- Volz, R.G., Lieb, M., and Benjamin, J. (1980). Biomechanics of the wrist. Clinical Orthopedics and Related Research, 149, 112-117.
- Von Lanz, T., and Wachsmuth, W. (1959). Praktische anatomie: Arm (in German). Bern, Germany: Springer-Verlag.



- Weber, E.R. (1980). Biomechanical implications of scaphoid waist fractures. Clinical Orthopedics and Related Research, 149, 83-89.
- Weber, E.R. (1984). Concepts governing the rotational shift of the intercalated segment of the carpus. Orthopaedic Clinics of North America, 15(2), 193-207.
- Weber, E.R. (1988). Wrist mechanics and its association with ligamentous instability. In D.M. Lichtman (Ed.), The wrist and its disorders (pp.41-53). Philadelphia, PA: Saunders.
- Weber, E.R., and Chao, E.Y. (1978). An experimental approach to the mechanism of scaphoid waist fractures. Journal of Hand Surgery, 3(2), 142-148.
- Wehbe, M.A., and Hunter, J.M. (1985). Flexor tendon gliding in the hand: Part I. In vivo excursions. Journal of Hand Surgery, 10A(4), 570-574.
- Winer, B.J. (1971). Statistical principles in experimental design (2nd ed.). New York, NY: McGraw-Hill Book Co.
- Woodson, B. (1981). Human factors design handbook. New York, NY: McGraw-Hill.
- Woody, R., and Mathiowetz, V. (1988). Effect of forearm position on pinch strength measurements. Journal of Hand Therapy, 1(3), 124-126.
- Wright, R.D. (1935). A detailed study of movement of the wrist joint. Journal of Anatomy, 70, 137-142.
- Youm, Y., and Flatt, A.E. (1980). Kinematics of the wrist. Clinical Orthopedics and Related Research, 149, 21-32.
- Youm, Y., Gillespie, T.E., Flatt, A.E., and Sprague, B.L. (1978). Kinematic investigation of normal MCP joint. Journal of Biomechanics, 11, 109-118.
- Youm, Y., McMurtry, R.Y., Flatt, A.E., and Gillespie, T.E. (1978). Kinematics of the wrist: An experimental study of radial-ulnar deviation and flexion-extension. Journal of Bone and Joint Surgery, 60A(4), 423-431.
- Youm, Y., and Yoon, Y.S. (1979). Analytical development in investigation of wrist kinematics. Journal of Biomechanics, 12, 613-621.

## CARPAL ANATOMY

### Carpal Bones

Scaphoid (Navicular). The scaphoid is very irregular in shape and difficult to describe. The comparison to a boat, which gave this bone its name (scaphe - Greek for "dugout", trough, or boat), is strained (Kaplan and Taleisnik, 1984).

The scaphoid is the most radially situated bone in the proximal row and is also the largest in that row. Its proximal surface is biconvex for articulation with the scaphoid facet on the distal radius. The distal surface is smooth and convex for articulation with the trapezium and trapezoid. The dorsal surface is rough and irregular and represents an attachment site for the dorsal radiocarpal ligament and radial collateral ligaments on the waist of the scaphoid. There are numerous perforations in this surface for small blood vessels to pass into the interior of the bone. The palmar surface has an irregular area for the attachment of volar ligaments as well as a rounded projection, called Lister's tubercle (of the scaphoid), to which the transverse flexor retinaculum is attached. The medial surface has a small, elongated semilunar articular surface for articulation with the lunate and a large concavity that occupies much of the medial surface of the bone for articulation with the head of the capitate (Bogumill, 1988).

Wright (1935) states the scaphoid shows a wide range of movement in relation to the other bones of the proximal carpal row. It also articulates both with the proximal and distal carpal rows (MacConaill, 1941).

The scaphoid articulates with five bones: the radius proximally, the trapezium and the trapezoid distally, and the capitate and lunate medially.

Lunate (Semi-lunar). The lunate owes its name to its distal articular facet, semi-lunar in shape, for articulation with the head of the capitate and hamate bones (Kaplan and Taleisnik, 1984). The lunate is the "lynch-pin" of the wrist; the mobility and stability of the carpus depend upon its integrity (Fisk, 1984).

This bone is located between the scaphoid radially and the triquetrum medially. It is deeply concave on its distal surface for articulation with the capitate; it is convex

proximally for articulation with the lunate facet of the distal radius. Medially it has a large, flattened facet for articulation with the triquetrum, and laterally it has a similar flattened facet for articulation with the proximal end of the scaphoid. There are small areas on the dorsal and palmar surfaces for ligamentous attachment, through which the blood supply to the lunate passes. These small areas provide a rather tenuous attachment of ligaments in addition to providing for blood supply (Bogumill, 1988).

The lunate articulates with five bones: the radius proximally, capitate and hamate distally, scaphoid laterally and triquetrum medially.

Triquetrum (Triquetral, Triangular, Pyramidal(e), Cuneiform). The triquetrum, located on the ulnar side of the proximal row, is pyramid-shaped with its apex medial and distal and its base lateral. The convex proximal surface has a smooth portion that articulates with the triangular fibrocartilage of the wrist and has a roughened surface for attachment of the ulnar collateral ligament. The distal surface is concave for articulation with the hamate and has a spiral configuration that exerts an important influence on relative motion between the two rows. The palmar surface has an oval facet for articulation with a similar facet on the pisiform; the remainder of this palmar surface as well as the entire dorsal surface is rough, permitting attachment of capsular ligaments. The smooth, flattened lateral surface is covered with hyaline cartilage, which allows for articulation with the lunate. The medial surface, which is the apex of the pyramid, is rough, permitting attachment of the ulnar collateral ligament (Bogumill, 1988).

The triquetrum articulates with three bones: the lunate laterally, the pisiform anteriorly, and the hamate distally. It also articulates with the triangular fibrocartilage and occasionally with the distal radius, depending on the position of the wrist.

Pisiform. The pisiform bone is small and rounded on most surfaces; but has a singular articular facet by which it articulates with the anterior surface of the triquetrum (Bogumill, 1988). Although it is anatomically part of the proximal row, it does not participate in the articulation (Norkin and Levangie, 1983). The remainder of the bone allows for the attachment of the flexor carpi ulnaris tendon and its continuations, the

pisohamate and pisometacarpal ligaments. It also provides attachment for part of the abductor digiti minimi as well as medial attachment for the flexor retinaculum (Bogumill, 1988). Normally, the pisiform is completely covered by the fibers of the abductor digiti minimi and the tendon insertion of the flexor carpi ulnaris (Kaplan and Taleisnik, 1984). This makes the pisiform a sesamoid bone (nodular mass) within the tendon of the flexor carpi ulnaris (Norkin and Levangie, 1983).

The pisiform articulates with only one bone, the triquetrum, and is not considered part of the articular surface for the proximal row.

Trapezium (Multangular Major, Greater Multangular). The trapezium plays a significant role in the function of the wrist and thumb. It is pentagon shaped, with five sides in addition to its volar and dorsal surfaces. The two proximal sides are articular surfaces that meet at an angle; lateral for the scaphoid and medial for the trapezoid. The medial facet articulates with the base of the second metacarpal (Kaplan and Taleisnik, 1984).

The trapezium is the most radially situated bone in the distal carpal row. On its palmar surface there is a deep groove that is converted by a ligament into a tunnel for the flexor carpi radialis tendon. The proximal surface is smooth and somewhat flattened, where it articulates with the distal end of the scaphoid (Bogumill, 1988). The scaphoid and trapezium make up the floor of the "anatomical snuff box" (fovea radialis), the depression seen between the tendons of the thumb extensor muscles (Extensor pollicis longus and brevis) when these muscles are contracted (Brunnstrom, 1972). The distal surface is saddle-shaped for articulation with the base of the first metacarpal (Bogumill, 1988; Kaplan and Taleisnik, 1984). The dorsal and palmar surfaces are rough and irregular, allowing for ligamentous and capsular attachments. The palmar surface, however, is somewhat smooth where it transmits the flexor carpi-radialis tendon. On the lateral aspect of this deep palmar groove is a bony prominence or tuberosity that gives lateral attachment to the flexor retinaculum. The medial surface has two articular facets, the first for articulation with the trapezoid, the second for

articulation with the base of the second metacarpal; this latter facet is quite small but distinct (Bogumill, 1988).

The trapezium articulates with three bones: the scaphoid laterally, the trapezoid medially, and the third metacarpal distally.

Trapezoid (Multangular Minor). The trapezoid is the smallest bone in the distal row. It is wedge-shaped, with the apex on the palmar surface and the base located dorsally. The proximal surface is flattened and smooth, allowing for articulation with the scaphoid. The distal surface is also smooth, but has a longitudinal ridge that divides it into two facets, both of which articulate with the proximal end of the second metacarpal. The dorsal and palmar surfaces are rough, permitting attachment of ligaments; the lateral surface is smooth for articulation with the trapezium; the medial surface is convex and smooth for articulation with the capitate. There is usually a fairly strong interosseous ligament between the capitate and the trapezoid in the center of this medial surface (Bogumill, 1988).

The trapezoid articulates with four bones: the scaphoid proximally, second metacarpal distally, trapezium laterally, and capitate medially.

Capitate (Os Magnum). The capitate is the largest, most massive carpal bone (Bogumill, 1988; Kaplan and Taleisnik, 1984). It has a well-developed, round head that is responsible for the name capitate (Kaplan and Taleisnik, 1984). It is situated in the center of the wrist (in line with the long axis of digit 3) and is called the center of wrist motion in all planes by Brunnstrom (1972). Proximally, the surface is convex, smooth, and separated from the remainder of the bone by a relatively constricted area or neck; this proximal head articulates with the scaphoid and lunate bones (Bogumill, 1988). The entire portion of the bone below the narrow neck is the body of the capitate (Kaplan and Taleisnik, 1984). The distal surface is divided by two ridges into three facets for articulation with the second, third, and fourth metacarpals. The dorsal surface is broad and rough, permitting attachment of ligaments and capsules and for penetration of blood vessels. The palmar surface is, likewise, rough, allowing for attachment of the very

strong thick anterior ligaments and a portion of the adductor pollicis muscle. The lateral surface articulates with the trapezoid distally and the scaphoid proximally; there is a rough area in between that allows for attachment of ligaments. The medial surface articulates with the hamate by an elongated smooth facet that is somewhat irregular in shape but generally flattened (Bogumill, 1988).

The capitate articulates with seven bones: the scaphoid and lunate proximally, the second, third, and fourth metacarpals distally, the trapezoid radially, and the hamate on the ulnar side.

Hamate (Os Unciform). The hamate, the most medial bone in the distal row, is easily identified by the pronounced hook (hamulus) projecting from its palmar surface (Bogumill, 1988; Kaplan and Taleisnik, 1984). The hamulus is curved towards the lateral surface and gives attachment at its apex to the flexor retinaculum as well as to the origin of the flexor digiti minimi; it also provides insertion to the flexor carpi ulnaris through the pisohamate ligament. The proximal surface is narrow, convex, and smooth for articulation with the lunate. The distal surface articulates with the fourth and fifth metacarpals by two facets that are separated by an anteroposterior ridge. The dorsal surface is triangular in shape, roughened, and provides for ligamentous attachment. The lateral surface has a deep concavity formed by the body and the hamulus; this provides a pulley mechanism for the flexor tendons passing from the forearm to the fingers. The ulnar surface articulates with the triquetrum by means of an oval, elongated facet, and the radial surface articulates with the capitate through a similarly elongated and flattened facet. The spiral orientation of the triquetro-hamate joint exerts an important influence on the relative motion between the two carpal rows (Bogumill, 1988).

The hamulus makes up one of the four prominences on the palmar aspect of the carpus for attachment of the flexor retinaculum. The other three prominences are the pisiform, the tuberosity of the scaphoid, and the oblique ridge of the trapezium.

The hamate articulates with five bones: the lunate proximally, the fourth and fifth metacarpals distally, the triquetrum medially, and the capitate laterally.

### Ligaments

It is generally accepted that the stability of the carpal joint system, despite the variable positions of the carpal bones, essentially depends on the ligamentous structure(s) (Fisk, 1980; Kauer and de Lange, 1987; Mayfield, 1979, 1984; Taleisnik, 1986). The wrist ligaments resemble parts of a puzzle, each having little significance alone, but when combined to form a unit, they become the basis of carpal stability and they also limit carpal motion (Mayfield, 1988). One role of the ligaments is control of the relative motion of the two carpal joints (Gilford et al., 1943; Mayfield, 1980; Weber, 1984; Weber and Chao, 1978). Ligaments are "static structures" which are either taut, limiting the excursion of the joint system involved, or lax, not affecting joint motion (Weber, 1984). From a functional point of view, the ligaments of the wrist can be regarded as a system that passively restricts the movements of the carpal bones on one another and upon the radius. The ligaments fine-tune the positions of the carpal bones in flexion, extension, and deviation, while counteracting the tendency for axial rotation of the hand with respect to the radius (Kauer and de Lange, 1987; Norkin and Levangie, 1983).

Extrinsic ligaments cross the carpal bones, while intrinsic ligaments are contained within the carpal rows (Norkin and Levangie, 1983; Weber, 1984, 1988). Mechanically, the extrinsic ligaments are stiffer, while the intrinsic ligaments are capable of greater elongation before permanent deformation occurs (Taleisnik, 1988).

Extrinsic ligaments of the wrist course between the carpus and the radius and cover all quadrants of the joint; radial, volar, ulnar, and dorsal (Kaplan and Taleisnik, 1984). The function of the ligaments crossing the carpal rows is to guide the excursion of one row (the proximal row) upon the second row (the distal row). These ligaments include the radiolunatotriquetral ligament, the dorsal carpal ligament, the ulnotriquetral ligament, and the radioscapolunate ligament.

The intrinsic ligaments, contained within the carpal row, act to limit the relative motion between the carpal bones within each row and bind the proximal row into a stable unit (Weber, 1984, 1988). These intrinsic ligaments of the wrist originate and insert on the carpal bones (Kaplan and Taleisnik, 1984; Norkin and Levangie, 1983). The intrinsic ligaments are short, stout, and unyielding. Dorsal, volar, and interosseous fibers bind the four bones of the distal carpal row into a single functional unit (Kaplan and Taleisnik, 1984).

The transverse ligament of the carpus functions to maintain the transverse arch of the carpus in addition to being a retinaculum, creating a carpal tunnel, through which the flexor tendons pass (Putz-Anderson, 1988; Wright, 1935). The walls of the carpal tunnel are formed by the arched carpal bones and its roof is formed by the transverse ligament (retinaculum) (Putz-Anderson, 1988).

The two collateral ligaments have axes in different lines. The ulnar collateral ligament is distributed over the ulnar, volar, and dorsal surfaces of the triquetrum and hamate. The longitudinal portion of the radial collateral ligament is attached wholly to the volar surface of the styloid process of the radius and to the volar surface of Lister's tubercle on the scaphoid. This ligament prevents the movement of the scaphoid past the neutral (straight) position in extension of the wrist (Wright, 1935).

The interosseous ligaments of the two carpal rows vary greatly in strength. The ligament uniting the lunate and the scaphoid is poorly developed in the middle portion; the volar and dorsal portions are much longer than the distance between these two bones when they are closely packed. This allows the movement of the scaphoid bone relative to the lunate in flexion, and that of the lunate on the scaphoid in extension. The relative immobility of the triquetrum on the lunate is due to the large contact surface, as well as the volar and dorsal ligaments rather than due to the interosseous ligament; the capitate is feebly joined to the trapezoid and the trapezium is weakly joined to these two bones (Wright, 1935). The proximal carpal row is stabilized and joined to the distal forearm by five ligaments, whereas the distal row is stabilized and joined to the forearm by only one



ligament, the radiocapitate ligament which is the weakest of all carpal ligaments (Mayfield, 1988).

The interosseous ligament links the scaphoid and lunate, inserting into the opposite borders of the proximal joint surfaces of both bones. The volar part of the ligament is considerably longer than the dorsal part, since the two bones diverge volarly. The dorsal part of the junction is much denser than the volar part, where strong fibers are mingled with loose tissue and vessels. This ligament permits displacement between the volar parts of the scaphoid and the lunate, while the dorsal parts are kept tightly together. This is confirmed by the observations on mobility in an isolated proximal carpal row; the scaphoid and the lunate move with respect to each other like a pair of scissors, the pivot being located in the dorsal part of the interosseous ligament (Kauer, 1974).

The displacement between the scaphoid and lunate, resulting from their rotation in differently curved joints, changes the direction of the fibers of the interosseous ligament. Consequently, the enlargement of the joint space present in the end-position of extension is reduced in flexion. This implies that in addition to the forward and backward rotation, both the scaphoid and lunate rotate in a transverse plane. Such a rotation causes both the scaphoid and lunate to contribute to the closure of the volar part of the joint cleft between them (Kauer, 1974).

### Muscles and Tendons

Each human has approximately 24 tendons crossing the wrist, some people have fewer tendons (e.g., missing palmaris longus) and some have more than 24 tendons (e.g., bifurcations or trifurcations of tendons proximal to the wrist). Of the tendons crossing the wrist only 6 are dedicated wrist moving muscles: the extensor carpi radialis longus, extensor carpi radialis brevis, extensor carpi ulnaris, flexor carpi radialis, flexor carpi ulnaris and palmaris longus (Brand, 1985). There are three wrist extensors (shown in Figure 17) and three wrist flexors (shown in Figure 18). As shown in Table 20, these flexor and extensor muscles also deviate and circumduct the wrist (Kaplan and Taleisnik, 1984; Bunnell, 1948). The (6) muscles of the wrist are arrayed around the perimeter of

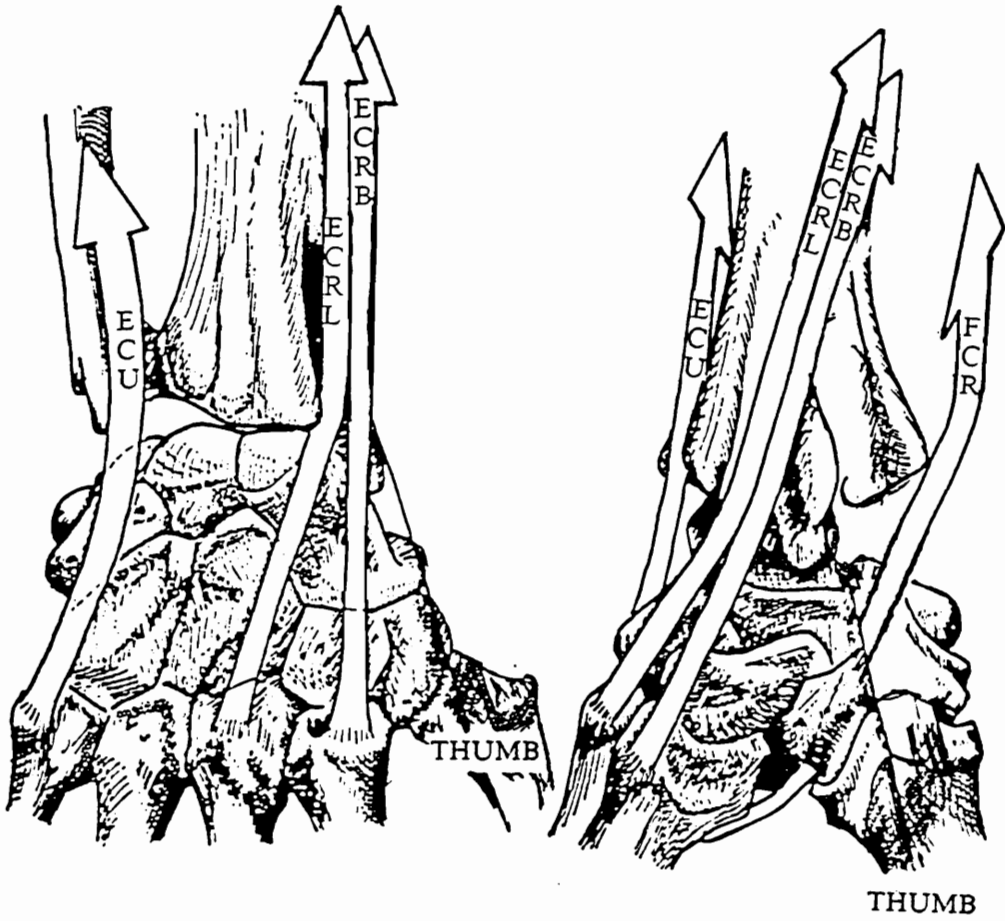

Figure 17. Wrist extensor muscles. Dorsal (A) and radial (B) views of the right hand (adapted from Kapandji, 1968).

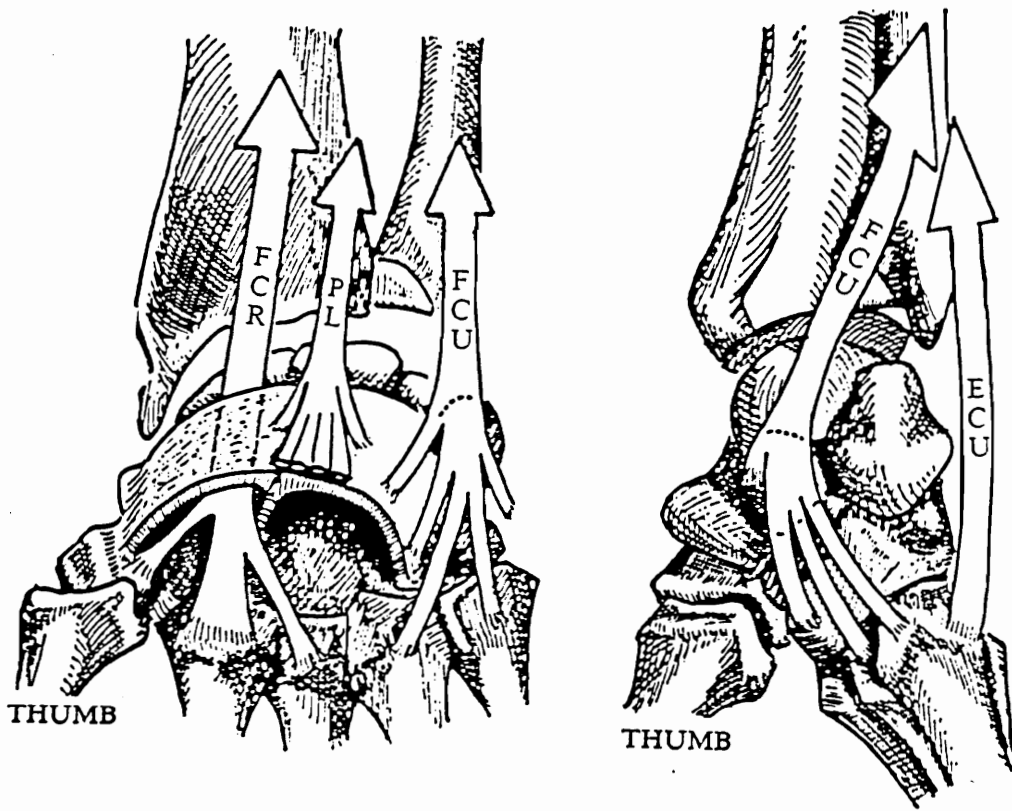

Figure 18. Wrist flexor muscles. Palmar (A) and ulnar (B) views of the right hand (adapted from Kapandji, 1968).

the carpus in a fashion that provides optimal moments arms for wrist control (Linscheid, 1986). The moment supplied by each tendon is a function of the perpendicular distance of each to the ICOR. Since each ICOR point is fixed and the tendons are constrained to narrow areas as they cross the wrist by the retinaculae or tendon sheaths, the moment arms are relatively constant over the ROM (Linscheid, 1986).

Extensor carpi radialis longus. The extensor carpi radialis longus (ECRL) is listed as an extensor of the wrist, but it has larger moment arms for flexion of the elbow and for radial deviation of the wrist than it has for wrist extension (Brunnstrom, 1972). However, the ECRL functions as the major antagonist of the flexor carpi ulnaris (FCU). The combination of the ECRL and FCU, a combination of radial wrist extension and ulnar wrist flexion, as basic as simple flexion-extension without deviation (Brand, 1985).

Extensor carpi radialis brevis. The extensor carpi radialis brevis (ECRB), while smaller in mass than the ECRL, is a more effective wrist extensor because it has a larger moment arm for extension and a smaller moment arm for radial deviation than the ECRL and, unlike the ECRL, it is not affected by elbow position (Brand, 1985).

Extensor carpi ulnaris. The extensor carpi ulnaris (ECU), is unique in that the distal portion of its tendon attaches to the head of the ulna. All other tendons that cross the wrist move with the radius as it moves around the ulna into pronation and supination. Since the radius carries the carpal bones, with the axes of flexion-extension and radial-ulnar deviation, it follows that the ECU changes its relationship to the axes of wrist movement and is an effective wrist extensor only in supination and not an extensor at all when the forearm is pronated (Brand, 1985).

Flexor carpi ulnaris. The flexor carpi ulnaris (FCU) can exert the highest tension of all the tendons that cross the wrist, and has the smallest potential excursion. Insertion of the FCU at the pisiform enhances its moment arm (Brand, 1985; Johnston, 1907).

Flexor carpi radialis. The flexor carpi radialis (FCR) is a prime wrist mover as it can exert almost as much tension as the ECU, but is only three-fifths as strong as the FCU (Brand, 1985).

The FCR originates from the medial epicondyle of the humerus, together with the pronator teres lateral to it and the palmaris longus medial to it. It arises from the common tendon and fascia that covers the muscles of the epicondylar group. The bi-pennate muscle ends in a tendon which, completely separated from all the other tendons in the carpal canal, passes under the flexor retinaculum to insert into the base of the second metacarpal (Kaplan and Taleisnik, 1984).

The FCR acts as a strong flexor of the wrist, transmitting its pull to the MC articulation, mostly on the radial side of the hand. It produces radial deviation of the wrist when acting with the ECRL (Kaplan and Smith, 1984). The FCR contracts strongly when the digit extensors are inaction. This contraction is apparently synergistic with the contraction of the extensors of the digits (Kaplan and Smith, 1984; MacConaill and Basmajian, 1977; Norkin and Levangie, 1983).

Palmaris longus. The palmaris longus (PL) is frequently absent in humans either unilaterally or bilaterally. Additionally, the PL location falls within a wide band on the palmar wrist surface. The PL is a pure flexor of the wrist and crosses the wrist on the outside of the retinaculae (Brand, 1985) as shown in Figure 18. The palmaris longus can be identified best when active wrist flexion is accompanied by opposition of the thumb and small finger (Brown and Lichtman, 1988).

Various authors have estimated the proportion of the population possessing the palmaris longus:

- 85% -- Taylor and Schwarz (1955); Cailliet (1971)
- 87% -- Brown and Lichtman (1988)
- 88-89% -- Kaplan and Taleisnik (1984)
- 90% -- Brand (1985); Youm et al. (1978).

Since the effect of a missing PL upon MVC is unknown, only subjects possessing the PL were employed in this study.

Digital muscles. Each individual has about 18 extrinsic digital muscles; the number and placement of these muscles varies among individuals (Cunningham, 1953). In

TABLE 20

Carpi Muscles Deviation

<i>Deviation</i>	<i>Extensors</i>	<i>Flexors</i>
<i>Ulnar</i>	Extensor carpi ulnaris (ECU)	Flexor carpi ulnaris
<i>Radial</i>	Extensor carpi radialis brevis (ECRB); Extensor carpi radialis longus (ECRL)	Flexor carpi radialis (FCR)
<i>Neutral</i>		Palmaris longus (PL)

addition, palpation of these muscles is difficult since many are deeply imbedded in the wrist and hand (Brown and Lichtman, 1988). Muscles whose tendons merely cross the wrist (secondary wrist movers) on route to the digits cannot be relied upon for their wrist moving and stabilizing characteristics, since wrist function may at times conflict with their primary digit function(s) (Brand, 1985). Thus, only the 6 carpi (wrist dedicated) muscles were employed in the flexion and extension force exertion measurements taken in this study.

### Carpal Tendons

Extensor tendons. The extensor tendons run on the ligament layer over the distal end of the radius and over the zone of the distal carpal row, but bridge over the proximal row (Kauer and Landsmeer, 1981; Radonjic and Long, 1971). The wrist extensors insert at the bases of the distal row and the carpometacarpal joints (Kauer and Landsmeer, 1981). A dorsal carpal ligament (extensor retinaculum) guides the extensor tendons (Taylor and Schwarz, 1955).

Flexor tendons and the flexor retinaculum. Flexor tendons pass through a "tunnel" bounded by carpal bones, laterally by the trapezium and the hamulus (hamate hook) and volarly by a tough transverse carpal ligament, the flexor retinaculum (Kauer and Landsmeer, 1981; Taylor and Schwarz, 1955). The hamulus is the major osseous anchorage of the flexor retinaculum (Kauer and Landsmeer, 1981). The flexor retinaculum is anchored radially into both the scaphoid and trapezium (Kauer and Landsmeer, 1981).

Tendons sheaths. Tendon sheaths, like slings or pulleys, hold a tendon close to the bone and serve to maintain its line of action (Thompson, 1981). The sheaths are responsible for the smooth gliding action of the tendon and for its low coefficient of friction (Thompson, 1981; Wehbe and Hunter, 1985). At each point where the tendon crosses a joint space, it has a moment or torque, tending to rotate one segment with respect to another (Thompson, 1981).

### Single Carpal Bone Position During Flexion and Extension

From the analysis of the changes in position of the carpal bones in flexion of the hand and from the relationship between these changes and the shape of the joint surfaces involved, the following conclusions were drawn by Kauer (1974):

1. The displacement of the trapezium and the trapezoid in (volar) flexion causes, without any perceptible delay, a volar rotation of the scaphoid. A shift occurs between the scaphoid and lunate.
2. The scaphoid and lunate are linked by the interosseous ligament. As a consequence, a volar rotation of the scaphoid is accompanied by a volar rotation of the lunate. The volar rotation of both the scaphoid and lunate with respect to the radius results in a mutual displacement of their proximal joint surfaces; the scaphoid shifts proximally with respect to the lunate. The interosseous ligament brings the volar parts of both bones together in flexion; in extension the bones gap volarly.
3. A shift of the scaphoid with respect to the lunate implies a shift with respect to the head of the capitate. The scaphoid is displaced volarly and proximally in flexion; dorsally and distally in extension. The scaphoid shifts in a volar direction because it rotates "faster" than the lunate with respect to the radius during flexion of the wrist. The scaphoid shifts with respect to the capitate in a proximal direction, as a result of the mutual displacement between the scaphoid and lunate. This displacement is amplified because in flexion the volar part of the lunate is interposed between the capitate and the radius.

The displacement of the scaphoid with respect to the head of the capitate results in a change in the orientation of this bone in the lateral projection, due to the shape of the radial facet on the head of the capitate; with the volar margin of the scaphoid deviated ulnarly and partially overlying the volar part of the head of the capitate.

4. The displacement of the lunate with respect to the capitate in flexion results in a deviation directed radially and arising from the irregular curvature of the median



facet on the head of the capitate. The decreasing curvature of the top of this facet, decreasing from the ulnar to the radial border, gives this facet a twisted aspect. In this way the lunate can shift with respect to the capitate without severe loss of contact.

The observation of the positional changes of the scaphoid and lunate with respect to each of the and with respect other distal carpals and the radius lead to the conclusion that these changes take place on two longitudinal chains of articulating bones. The changes in position of the scaphoid and lunate originating from a movement of the distal carpals with respect to the radius are interrelated in two ways.

- a. First, the interosseous ligament and the differences in curvature of the proximal joint surfaces of the scaphoid and lunate provide well defined locations of these two bones, dependent upon the positions of the distal carpals and the radius.
- b. Secondly, the positions of the scaphoid and lunate are mutually determined and interrelated by their displacements with respect to the head of the capitate (in two irregular curved joints).

These two modes are dependent on each other. Kauer (1974) suggested that this approach to the changes in position of the carpal bones from one end-position to another (flexion to extension) is the underlying mechanism of carpal motion. At the end-position of flexion, the volar margin of the scaphoid bone is in contact with the volar part of the radial facet on the head of the capitate. In extension, the head of the capitate advances to a more volar position and displaces the volar margin of the scaphoid bone radially. If this did not occur, the excursion of the head of the capitate in the volar direction would be blocked. However, in extension, the volar part of the interosseous ligament forces the scaphoid back into a dorsal rotation, accompanied by a distal displacement with respect to the lunate. Moreover, the loss of impact of the trapezium and trapezoid on the scaphoid in extension makes it possible for the lunate to

move into a dorsal rotation according to its wedging. The lunate leads the scaphoid further into dorsal rotation. The contact of the lunate with the median facet on the head of the capitate causes rotation in a transverse plane opposite to that occurring in flexion.

The coupling of the changes in position of the scaphoid and lunate results in specific positions of both bones, with respect to each other and to their individual articulation chains in every phase of wrist movement in the flexion/extension plane. The concept of interdependent articulation chains may offer a key to the analysis of the carpal mechanism (Kauer, 1974). Kauer (1974), however, only examined the end positions of flexion and extension, as well as the neutral position of the wrist to justify the articulation chain theory. In order to utilize the theory he evolved, he assumed that the bones move from neutral to the fully flexed or extended position in a smooth manner, with this movement proportional to the angle of the wrist.

The single carpal bone kinematics support the dual articular system, the intercalated link, and screw-vice concepts of wrist motion. The columnar concept is not supported by this kinematic literature since this concept is mainly concerned with control of the wrist and force transmission through the wrist rather than with positional changes.

## APPENDIX B. COMPUTER PROGRAM FOR METRABYTE® A/D CONVERTER

```
10 COLOR 14,1
15 cls
20 'Purpose: to gather wrist force measurements using
30 'two load cells; one for flexion and the
40 'other for extension of the wrist
50 'Date: June 1989
60 'Author: M. S. Hallbeck
120 'DECLARATIONS: DASH8 A/D CONVERTER
140 'LT%(X) CHANNEL SCAN LIMITS
150 'MD%(X) DASH8 CARD MODE SETTING
170 'FLAG% ERROR CODE FROM THE DASH8 CARD
180 'DIO%(0) DIGITAL I/O DATA FROM THE DASH8
190 'I,J,K,L INTEGER LOOP COUNTERS
200 'EN% ENABLE MODE TO ADD CHANNEL NUMBER TO DATA ARRAY
210 'SUB = SUBJECT NUMBER
220 'G = GENDER
230 'FL = FOREARM LENGTH
240 'FCD = DISTAL FOREARM CIRCUMFERENCE
245 'FCP = PROXIMAL FOREARM CIRCUMFERENCE
250 'WB = WRIST BREADTH
260 'WT = WRIST THICKNESS
270 'WC = WRIST CIRCUMFERENCE
280 'HL = HAND LENGTH
290 'HB = HAND BREADTH
300 'ROM = RANGE OF MOTION
310 DEFINT I,J,K,L,N,W
314 DEFSNG E,F,V
315 DIM DIO%(2)
316 DIM W(18)
320 DIM VOLT(6000)
325 DIM FORCE(6000)
340 DIM LT%(1)
350 'INITIALIZE DASH8 CARD AND ALL VARIABLES
360 DIO%(0)=0
370 BASADR%=&H300
390 MD%=0
400 FLAG%=0
410 CALL DASH8 (MD%, BASADR%, FLAG%)
420 'SEE THAT THERE IS NO ERROR CODE RETURNED FROM THE DASH8
430 IF FLAG% < > 0 THEN CLS ELSE 460
440 LOCATE 4,15: PRINT "RETURNED ERROR FROM DASH8"
450 GOTO 3000
460 LOCATE 4,15: PRINT "WRIST FORCE MEASUREMENT PROGRAM"
470 LOCATE 8,15: input "HIT ANY KEY TO START PROGRAM OR 'Q' TO QUIT ",
  A$
490 IF A$="q" THEN 3000
495 IF A$="Q" THEN 3000
500 CLS
510 LOCATE 1,2: INPUT "ENTER DATA FILE NAME (WITH EXTENSION)", F$
520 LOCATE 2,2: INPUT "ENTER SUBJECT NUMBER:", SB
530 LOCATE 3,2: INPUT "ENTER SUBJECT GENDER:", G$
540 LOCATE 4,2: INPUT "ENTER FOREARM LENGTH:", FL
550 LOCATE 5,2: INPUT "ENTER DISTAL FOREARM CIRCUMFERENCE:", FCD
560 LOCATE 6,2: INPUT "ENTER PROXIMAL FOREARM CIRCUMFERENCE:",FCP
```

```

570 LOCATE 7,2: INPUT "ENTER WRIST BREADTH:", WB
580 LOCATE 8,2: INPUT "ENTER WRIST THICKNESS:", WT
590 LOCATE 9,2: INPUT "ENTER WRIST CIRCUMFERENCE:", WC
600 LOCATE 10,2: INPUT "ENTER HAND LENGTH:", HL
610 LOCATE 11,2: INPUT "ENTER HAND BREADTH:", HB
620 LOCATE 12,2: INPUT "ENTER ACTIVE RANGE OF MOTION:", ROM
630 LOCATE 13,2: INPUT "ENTER TOTAL NUMBER OF WRIST POSITIONS TO BE
TESTED:", WPS
640 LOCATE 16,2: INPUT "IS THE ABOVE INFORMATION CORRECT? Y/N", B$
660 IF B$="N" THEN 520
665 IF B$="n" THEN 520
670 IF B$="Y" THEN 680
675 IF B$="y" THEN 680 ELSE 640
680 MEAS=0
700 'RANDOMIZE WRIST POSITIONS OVER SUBJECT'S ROM, THE RND
FUNCTION
710 'WILL BE USED, WITH THE NUMBER OF POSITIONS AS THE RANDOM SEED
715 P=WPS
720 FOR I=1 TO WPS
730 W(I)=INT (RND * (P+1))
740 IF W(I)=0 THEN 730
741 FOR N=1 TO WPS
743 IF W(I)=W(I-N) THEN 730
745 NEXT N 750 PRINT USING "###"; W(I)
760 NEXT I
770 LOCATE 20,4 : INPUT "HAVE YOU RECORDED THE ORDER OF THE
POSITIONS? Y/N", P$
790 IF P$="Y" OR P$="y" THEN 810 ELSE 770
810 'THIS WILL ALLOW THE NUMBERS TO BE WRITTEN DOWN AND A PAUSE
UNTIL DONE
820 CLS
822 MEAS=0
824 TOTMEAS=2*WPS
830 FOR I=1 TO WPS
840 LOCATE 4,2: INPUT "WHICH WRIST POSITION IS TO BE TESTED?", WP
850 IF WP> WPS THEN 840
930 LOCATE 16,2: PRINT "*** READY TO COLLECT DATA ***"
940 LOCATE 18,2: PRINT "HIT ANY KEY TO BEGIN FLEXION DATA
COLLECTION"
950 A$=INKEY$
955 IF A$="" THEN 930
960 MEAS=MEAS+1
970 IF MEAS>TOTMEAS THEN 3000
980 MD%=1
990 LT%(0)=0
1000 LT%(1)=0
1010 FLAG%=0
1020 CALL DASH8 (MD%, LT%(0), FLAG%)
1030 IF FLAG% <> 0 THEN 3000
1040 'FLEXION FORCE MEASUREMENT SECTION
1050 MD%=4
1060 DIO%(0)=0
1070 FLAG%=0
1071 BEEP
1072 FOR K=1 TO 6000
1080 CALL DASH8 (MD%,DIO%(0),FLAG%)

```

```

1110 IF FLAG% < > 0 THEN 3000
1130 VOLT(K) = (DIO%(0))
1160 NEXT K
1170 BEEP
1180 CLS
1190 ' CHECK DATA FOR ACCEPTANCE CRITERIA
1200 FSUM = 0
1210 FSUMSQ = 0
1220 FOR L=1500 TO 6000
1230 FORCE(L) = (VOLT(L))
1240 FSUM=FORCE(L)+FSUM
1250 NEXT L
1260 FPEAK = 0
1265 FPK = 0
1270 FOR K= 1 TO 6000
1290 IF FORCE(K) > FPK THEN FPK=FORCE(K)
1300 NEXT K
1310 FPEAK = CSNG(FPK)
1320 FAVG = FSUM / 4500 ' RUNNING AVERAGE CALCULATION
1330 FAV = CSNG(FAVG)
1390 'SET BOUNDARIES FOR DATA ACCEPTANCE
1400 FUL = FAV * 1.1 'AVERAGE FLEXION FORCE + 10%
1410 FLL = FAV * 0.9 'AVERAGE FLEXION FORCE - 10%
1420 FOR L= 1500 TO 6000
1430 IF FORCE(L) >FUL THEN 1470
1440 IF FORCE(L) <FLL THEN 1470
1450 NEXT L
1451 FOR L = 1500 TO 6000
1452 FSUMSQ = ((FORCE(L) - FAVG)^2) +FSUMSQ
1453 NEXT L
1455 fpeak = fpeak * 0.06134
1456 fav = fav * 0.06134
1457 fsumsq = fsumsq * 0.06134
1458 FSTDEV = SQR(FSUMSQ)/4500 'STANDARD DEVIATION CALCULATION
1459 FSTD = CSNG(FSTDEV)
1460 GOTO 1550
1470 CLS
1480 LOCATE 4,2: PRINT" UNACCEPTABLE MEASURE"
1490 MEAS=MEAS-1
1500 MD% = 2 'MODE 2 SETS CHANNEL BACK TO FLEXION LOAD CELL
1510 CH% = 0
1520 FLAG% = 0
1530 CALL DASH8(MD%, CH%, FLAG%)
1535 IF FLAG% < > 0 THEN 3000 ELSE 930
1550 CLS
1560 LOCATE 4,2: PRINT USING "FPEAK = #####.##"; FPEAK
1570 LOCATE 6,2: PRINT USING "FAVG = #####.##"; FAV
1580 LOCATE 8,2: PRINT USING "F STD DEV = ###.#####"; FSTD
1590 LOCATE 16,2: PRINT"GOOD MEASUREMENT! NOW GET READY TO
PERFORM EXTENSION"
1600 LOCATE 18,2: PRINT"HIT ANY KEY TO BEGIN EXTENSION DATA
COLLECTION"
1610 A$ = INKEY$
1620 IF A$="" THEN 1600
1630 MEAS = MEAS+1
1640 IF MEAS>TOTMEAS THEN 3000

```

```

1980 MD%=1
1990 LT%(0)=1
2000 LT%(1)=1
2010 FLAG%=0
2020 CALL DASH8 (MD%, LT%(0), FLAG%)
2030 IF FLAG% <> 0 THEN 3000
2040 'EXTENSION FORCE MEASUREMENT SECTION
2050 MD%=4
2060 DIO%(0)=0
2070 FLAG%=0
2071 BEEP
2072 FOR K=1 TO 6000
2080 CALL DASH8 (MD%,DIO%(0),FLAG%)
2110 IF FLAG% < > 0 THEN 3000
2140 VOLT(K) = (DIO%(0))
2160 NEXT K
2170 BEEP
2180 CLS
2190 ' CHECK DATA FOR ACCEPTANCE CRITERIA
2200 ESUM = 0
2210 ESUMSQ = 0
2220 FOR L=1500 TO 6000
2230 FORCE(L) = (VOLT(L))
2240 ESUM=FORCE(L) +ESUM
2250 NEXT L
2260 EPEAK = 0
2265 EPK = 0
2270 FOR K= 1 TO 6000
2290 IF FORCE(K) > EPK THEN EPK=FORCE(K)
2300 NEXT K
2310 EPEAK = CSNG(EPK)
2320 EAVG = ESUM / 4500      ' RUNNING AVERAGE CALCULATION
2330 EAV = CSNG(EAVG)
2390 'SET BOUNDARIES FOR DATA ACCEPTANCE
2400 EUL = EAV * 1.1      'AVERAGE FLEXION FORCE + 10%
2410 ELL = EAV * 0.9      'AVERAGE FLEXION FORCE - 10%
2420 FOR L= 1500 TO 6000
2430 IF FORCE(L) >EUL THEN 2470
2440 IF FORCE(L) <ELL THEN 2470
2441 ESUMSQ = ((FORCE(L) - EAVG)^2) +ESUMSQ
2442 NEXT L
2443 eav=eav * 0.06030
2444 epeak = epeak * 0.0603
2445 esumsq=esumsq *0.06030
2446 ESTDEV = SQR(ESUMSQ)/4500 'STANDARD DEVIATION CALCULATION
2450 ESTD = CSNG(ESTDEV)
2460 GOTO 2550
2470 CLS
2480 LOCATE 4,2: PRINT" UNACCEPTABLE MEASURE"
2490 MEAS=MEAS-1
2500 MD% = 2 'MODE 2 SETS CHANNEL BACK TO FLEXION LOAD CELL
2510 CH% = 1
2520 FLAG% = 0
2530 CALL DASH8(MD%, CH%, FLAG%)
2540 IF FLAG% < > 0 THEN 3000 ELSE 1600
2550 CLS

```

```

2560 LOCATE 4,2: PRINT USING "EPEAK = #####.##"; EPEAK
2570 LOCATE 6,2: PRINT USING "EAVG = #####.##"; EAV
2580 LOCATE 8,2: PRINT USING "E STD DEV = ###.####"; ESTD
2590 LOCATE 16,2: PRINT" GOOD MEASUREMENT! NOW GET READY TO
      PERFORM FLEXION IN NEXT WRIST POSITION"
2610 OPEN F$ FOR APPEND AS #1 'OPENING DATA FILE
2620 PRINT #1, TAB(3) SB TAB(7) G$ TAB(10) FL TAB(16) FCD TAB(22) FCP
      TAB(28) WB TAB(34) WT;
2630 PRINT #1, TAB(40) WC TAB(46) HL TAB(52) HB TAB(58) ROM TAB (63) WP
      TAB(67) FPEAK;
2640 PRINT #1, TAB(77) FAV TAB(87) FSTD TAB(104) EPEAK TAB(114) EAV
      TAB(124) ESTD
2645 CLOSE #1
2650 NEXT I
3000 CLS
3010 LOCATE 4,2: PRINT"END OF SESSION"
3020 LOCATE 6,2: INPUT"HIT ANY KEY TO RUN ANOTHER SESSION OR 'Q' TO
      QUIT ", A$
3040 IF A$="Q" THEN 3060
3050 IF A$="q" THEN 3060 ELSE 500
3060 CLS
3070 END

```

## APPENDIX C. CONSENT FORM

I, \_\_\_\_\_, am participating in this research study because I want to. The decision to participate is completely voluntary on my part. No one has coerced or intimidated me to participate.

Susan Hallbeck has adequately answered any and all questions I have asked about this study, my participation, and the procedures involved, which are described in the attachment to this consent form, which I have initialled.

I understand that the Principal Investigator or his assistant will be available to answer any questions concerning procedures throughout this study. I understand that if significant new findings develop during the course of this research which may relate to my decision to continue participation, I will be informed. I further understand that I may withdraw this consent at any time and discontinue further participation without prejudice to my entitlements. I also understand that the Principal Investigator, his assistant, or a medical consultant for this study may terminate my participation in this study if he or she feels this to be in my best interest. I may be required to undergo certain further examinations, if they are necessary for my health and/or well-being.

I do not have any disorders of my cardiovascular system, or my spinal column (particularly the low back), within my arms (particularly the wrist), or any other disorders or deficiencies, which make it inadvisable for me to participate as a subject in this experiment.

I understand that in the case of physical injury no medical treatment nor compensation are offered under the research program, or by Virginia Tech (Virginia Polytechnic Institute and State University).

I understand that for my participation I shall receive payment in the amount of \$5.00, which will be prorated if I do not finish the complete one hour long experiment.

I understand that the results of my efforts will be recorded and that I may be photographed, filmed, or audio/videotaped. I consent to the use of this information for scientific or training purposes and understand that any records of my participation in





converted into signals which are recorded. You will be asked to exert a force as large and/or long as possible without injury.

The experimenter has no control over the magnitude of your exertion. You must be the judge of how much effort to exert in a given situation without risking injury. You are hereby instructed not to exert an effort great enough to cause injury. There is a mandatory rest period after each exertion. You may have additional rest whenever you desire.

You should be aware that overexertion can cause a strain or pulled muscle. Straining activities, such as this experiment, may contribute to increased risk, e.g., if you have a predisposition to hernia. It is possible that you will experience temporary muscle soreness, or fatigue, as a result of participation in this experiment.

Before your use as a test subject, you must inform the Principal Investigator and/or his assistant of any change to your physical status. This information will include any medication taken and any medical care directly affecting the experiment.

If you have any questions, we expect you to ask us. If you have any additional questions later, we will be happy to answer them. Professor Kroemer can be called at (703) 231-5677 during business hours and his assistant, Susan Hallbeck can be called at (703) 231-4882 to answer questions.

**YOU WILL BE GIVEN A COPY OF THIS FORM TO KEEP.**

Subject's Initials: \_\_\_\_\_

Physical Fitness Questionnaire

Subject's Name: \_\_\_\_\_

S.S.#: \_\_\_\_\_

Address: \_\_\_\_\_

Telephone: (    ) \_\_\_\_\_

Gender: \_\_\_\_\_ D.O.B.: \_\_\_\_\_ Experiment Date: \_\_\_\_\_

Which best describes your present physical condition (Circle One):

Poor    Fair    Good    Excellent

Describe your current physical exercises:

Sports (name):

\_\_\_\_\_ : \_\_\_\_\_ times per week  
\_\_\_\_\_ : \_\_\_\_\_ times per week

Other (name):

\_\_\_\_\_ : \_\_\_\_\_ times per week  
\_\_\_\_\_ : \_\_\_\_\_ times per week

Circle the appropriate answer and comment, if necessary.

Have you ever had a hernia?                      YES / NO

Have you ever had a back injury?              YES / NO

Have you had back pain in the last 6 months?    YES / NO

Have you ever had any back pain?              YES / NO

Have you ever had any joint dislocations?      YES / NO

Have you ever had any broken bones?           YES / NO

    If YES, the right wrist?                      YES / NO

Do you have any repetitive trauma injuries?    YES / NO

Do you have any orthopedic diseases?          YES / NO

    (If YES, explain)

Are you taking any drugs? (If YES, explain)    YES / NO

Write explanations/remarks to any question(s) on the back of this sheet.

---

Subject's Signature and Date

### Instructions for Wrist Study

Anthropometric measurements. First, anthropometric measurements including height, weight, forearm length, distal and proximal forearm circumferences, wrist breadth, wrist thickness, wrist circumference, hand length, and hand breadth will be taken using calipers and anthropometers as required.

Range of motion and instant center of rotation. Next, your hand and forearm will be placed in the measurement apparatus; your forearm in the box, restrained near the wrist and your hand in the handle. You will be seated in a conventional chair, with your right upper arm relaxed, hanging vertically, the elbow flexed at a right angle.

The active range of motion will be determined; the range of motion is the angle between extreme active flexion and extension that you can achieve with no discomfort. Then, a weight will be added to the pulley system over the handle; you will again move your wrist through the range of motion; the weight will be changed, and you will repeat this process.

Force measurement. After changing the apparatus, the experimenter will place your wrist in a series of positions within your active (unloaded) range of motion. In each position, you will be asked to build-up slowly to your maximal voluntary contraction, then hold this exertion as constant as you can for three (3) seconds; you will be asked to do this first for flexion, then extension.

If your exertion is not steady in the three second holding phase, you will be asked to repeat until the exertion is within tolerances.

You will use only those muscles directly affecting the wrist. You shall relax your fingers, not stiffen, flex, or hyperextend them.

As you exert your maximal voluntary force, remember to breathe normally; do not hold your breath.

If you have any orthopedic wrist disorder that you think could affect you in this testing, you should tell the experimenter now, and not participate.

Remember, with relaxed fingers, contract the wrist muscles slowly, building up to your maximal voluntary exertion, then hold it for three seconds; breathing normally.

Are there any questions?

#### APPENDIX D. COMPUTER PROGRAM FOR CENTER OF ROTATION

```

10 open "cor.dat" for append as #1
20 open "bisect.dat" for append as #2
29 dim db(7)
30 dim mix(7)
31 dim miy(7)
32 dim mox(7)
33 dim moy(7)
34 dim bo(7)
35 dim bi(7)
36 dim ao(7)
37 dim ai(7)
38 dim xint(7)
39 dim yint(7)
40 dim rad(7)
41 dim ox(2)
42 dim oy(2)
43 dim ix(2)
44 dim iy(2)
45 LOCATE 2,2: INPUT "INPUT THE SUBJECT NUMBER TO BEGIN WITH.", X
49 CLS
50 for s=X to 60      ' for all subjects
60 for LC=1 to 3     ' for load condition (nl/flex/ext)
65 locate 2,2: input "HOW MANY SQUARES ARE THERE PER INCH?",xx
70 for c=1 to 2     ' for red/black
80 for L=1 to 7     ' for the seven wrist positions
90 for m=1 to 2     ' for the left and right side of each position
100 cls
101 if S > 30 then g$="M" else g$="F"
102 if LC=1 then LC$="NL" ELSE IF LC=2 THEN LC$="FLEX" ELSE LC$="EXT"
103 IF C=1 THEN CC$="R" ELSE CC$="B"
104 PANG=30 + (L*15)
110 IF M=1 THEN MC$="L" ELSE MC$="R"
111 locate 2,2: print "SUBJECT", s
120 locate 4,2: print "LOAD CONDITION -- NL/FLEX/EXT", lc$
130 locate 6,2: print "RED/BLACK", cc$
140 locate 8,2: print "ANGLE AROUND WHICH THE POSITION IS BASED", pang
150 locate 10,2: print "LEFT/RIGHT SIDE OF SECTOR", mc$
160 locate 12,2: input "Outer Arc X Co-ordinate", ox(m)
170 locate 14,2: input "Outer Arc Y Co-ordinate", oy(m)
180 locate 16,2: input "Inner Arc X Co-ordinate", ix(m)
190 locate 18,2: input "Inner Arc Y Co-ordinate", iy(m)
191 ox(m)=ox(m)/xx
192 oy(m)=oy(m)/xx
193 ix(m)=ix(m)/xx
194 iy(m)=iy(m)/xx
200 print #1, tab(2) s tab(6) g$ tab(12) lc$ tab(19) cc$ tab(23) pang tab(30) mc$ tab(35)
ox(m) tab(40) oy(m) tab(48) ix(m) tab(56) iy(m)
210 next m
220 mix(l) = ( ix(2) - ix(1) ) / 2      'finding the midpoints of each arc...
230 miy(l) = ( iy(2) - iy(1) ) / 2
240 mox(l) = ( ox(2) - ox(1) ) / 2
250 moy(l) = ( oy(2) - oy(1) ) / 2
255 dox = (oy(2) - oy(1))

```

```

256 if doy=0 then doy=0.00001
260 bo(l) = -( ox(2) - ox(1)) / doy
265 diy = (iy(2) - iy(1))
266 if diy=0 then diy=0.00001
270 bi(l) = -( ix(2) - ix(1)) / diy
280 ao(l) = ( -bo(l) * mox(l)) + moy(l)
290 ai(l) = ( -bi(l) * mix(l)) + miy(l)
291 db(l) = bo(l) - bi(l)
292 if db(l) = 0 then db(l)=0.0000099
300 xint(l) = csng ((ai(l) - ao(l)) / (db(l)))
310 yint(l) = csng (bo(l) * (xint(l)) + ao(l))
320 rad(l) = csng ( sqr ( xint(l)^2 + yint(l)^2))
330 print #2, tab(2) s tab(6) g$ tab(12) lc$ tab(19) cc$ tab(23) pang tab(30) XINT(L)
TAB(50) YINT(L) TAB(70) RAD(L)
340 next L
350 next C
360 next LC
370 next S
390 close #1
400 close #2
410 end

```

**APPENDIX E. ANTHROPOMETRIC DATA**

**TABLE 21**

**Female Anthropometric Dimensions**

S #	G	FL (cm)	FCD (cm)	FCP (cm)	WB (cm)	WT (cm)	WC (cm)	HL (cm)	HB (cm)	ROM (deg)	Wgt (kg)	St (cm)
1	F	26.7	22.3	25.5	5.5	3.5	16.5	19.0	8.0	190	77.0	165.2
2	F	22.4	17.0	22.0	4.5	3.1	13.5	15.7	6.9	175	43.8	152.8
3	F	24.5	19.0	24.5	5.0	3.2	14.1	17.5	7.4	165	65.5	162.5
4	F	23.8	19.5	23.0	5.0	3.3	15.2	17.3	7.5	185	54.7	158.0
5	F	26.6	16.5	21.1	4.7	3.1	13.6	17.0	6.8	150	48.6	163.3
6	F	27.3	19.6	22.0	5.0	3.3	13.9	17.9	7.6	150	58.3	169.4
7	F	24.9	18.7	22.9	4.9	3.2	14.3	17.2	7.7	165	60.4	173.3
8	F	25.8	21.0	23.6	4.9	3.3	14.5	17.0	7.2	170	68.8	166.4
9	F	28.0	18.6	22.3	4.9	3.2	14.4	18.3	8.0	165	58.3	173.8
10	F	25.3	20.1	24.0	5.2	3.5	15.7	18.3	8.1	160	61.0	161.7
11	F	26.4	21.2	23.9	4.9	3.3	14.7	18.0	7.4	170	61.1	171.1
12	F	24.5	22.1	24.7	4.9	3.6	15.2	17.8	7.8	185	69.2	162.5
13	F	23.6	20.1	24.0	5.0	3.2	14.1	16.0	7.2	175	57.0	162.4
14	F	26.0	20.8	23.4	5.0	3.3	14.7	17.3	7.7	150	57.3	169.0
15	F	23.8	20.8	23.9	5.2	3.6	15.2	16.8	7.5	160	65.3	159.5
16	F	26.1	17.4	21.8	4.9	3.2	14.5	18.1	8.0	175	57.8	173.0
17	F	25.2	20.2	23.0	5.2	3.6	15.1	17.0	7.9	155	57.5	165.0
18	F	26.4	22.4	24.2	5.8	3.4	16.2	17.8	8.2	175	69.5	176.5
19	F	25.8	20.0	23.1	4.7	3.5	14.3	16.9	7.6	155	59.5	170.3
20	F	26.3	21.0	22.6	5.2	3.4	15.0	17.5	7.5	150	54.3	161.3
21	F	24.4	21.4	24.3	4.6	3.3	15.0	16.1	7.2	165	61.7	160.7
22	F	26.1	21.9	26.5	5.1	3.8	16.2	18.1	8.0	165	74.3	167.7
23	F	23.3	19.1	21.0	4.7	3.2	13.8	16.5	7.3	155	49.8	159.5
24	F	27.3	21.6	24.8	3.1	3.5	15.8	18.3	7.7	180	73.0	177.7
25	F	24.0	20.1	22.8	5.0	3.3	15.0	16.2	7.1	165	60.2	162.0
26	F	25.8	19.0	22.6	5.3	3.5	15.3	17.3	7.6	165	58.3	169.3
27	F	27.5	20.6	22.6	5.1	3.3	15.0	18.3	7.9	165	60.5	172.3
28	F	27.4	23.6	25.5	4.8	3.2	15.1	18.4	8.1	165	77.9	177.5
29	F	23.8	20.4	22.9	4.8	3.2	14.5	17.0	7.3	160	54.5	158.8
30	F	27.9	23.0	26.3	5.6	3.7	16.0	18.7	8.2	150	62.5	172
$\bar{x}$	F	25.56	20.3	23.5	5.02	3.36	14.88	17.44	7.613	164	61.5	166.5
s	F	1.495	1.692	1.395	0.284	0.181	0.784	0.84	0.383	13.48	8.055	6.430



TABLE 22

## Male Anthropometric Dimensions

S #	G	FL (cm)	FCD (cm)	FCP (cm)	WB (cm)	WT (cm)	WC (cm)	HL (cm)	HB (cm)	ROM (deg)	Wgt (kg)	St (cm)
31	M	30.4	24.2	28.0	6.1	4.1	17.1	20.0	10.0	180	79.5	189.9
32	M	30.2	23.6	26.7	5.6	3.6	16.0	18.2	8.3	180	85.4	174.0
33	M	30.3	18.8	24.0	5.5	3.4	15.1	19.4	8.4	180	56.0	177.7
34	M	28.7	25.7	30.5	6.0	4.0	18.6	20.0	9.1	150	89.2	181.4
35	M	27.8	22.8	25.2	5.9	3.7	16.5	19.0	8.4	120	64.8	178.0
36	M	30.7	23.6	26.8	6.0	3.7	17.2	19.6	8.8	190	77.4	182.5
37	M	31.6	25.9	28.5	6.2	4.0	17.8	21.1	9.3	185	86.1	194.1
38	M	26.6	22.6	25.8	5.3	4.0	15.7	18.4	8.3	150	64.3	171.7
39	M	29.4	24.7	28.9	6.0	4.0	17.0	18.6	8.7	145	93.0	172.6
40	M	31.5	23.1	24.5	6.1	3.8	17.7	21.6	9.1	170	67.5	195.4
41	M	27.9	24.8	28.8	6.0	4.2	17.4	19.2	8.3	155	82.0	174.0
42	M	28.7	24.0	28.7	5.9	4.1	17.3	18.9	8.6	165	83.4	179.6
43	M	27.2	21.6	27.1	5.4	3.5	16.9	18.0	8.3	140	67.0	174.4
44	M	27.7	25.0	28.1	5.9	3.9	17.3	17.9	8.8	130	72.0	170.1
45	M	30.8	26.5	29.3	6.0	4.1	17.9	20.3	8.7	155	82.7	188.5
46	M	28.6	23.4	26.4	5.5	3.6	16.8	19.9	9.2	145	65.0	179.1
47	M	25.7	27.8	31.3	6.3	4.4	18.1	18.2	8.3	90	94.5	165.6
48	M	28.4	27.4	29.5	5.7	4.4	17.2	20.1	9.2	60	77.5	182.5
49	M	31.2	23.9	28.1	6.1	3.9	17.3	20.3	8.9	135	84.6	184.4
50	M	29.1	22.1	26.0	5.8	3.7	16.5	19.4	8.2	160	65.6	185.1
51	M	30.3	21.2	25.6	5.5	3.7	16.2	19.0	8.4	130	67.1	181.8
52	M	28.0	26.0	28.7	5.9	4.0	17.2	19.9	9.1	175	82.8	185.4
53	M	29.0	24.4	29.3	5.9	4.0	17.6	20.0	9.1	150	92.6	178.1
54	M	29.7	27.1	29.6	6.2	4.0	17.5	20.1	9.2	150	92.0	187.7
55	M	28.0	23.6	27.4	5.4	4.0	16.1	17.9	7.9	165	86.5	174.6
56	M	31.8	23.0	28.5	6.0	4.0	17.2	20.9	9.1	180	81.3	196.9
57	M	29.0	26.0	28.5	5.8	3.9	17.0	19.3	8.5	160	79.1	181.4
58	M	30.4	23.0	28.9	5.7	3.7	17.4	20.6	9.0	150	89.0	184.2
59	M	26.3	21.3	26.0	5.3	3.6	16.5	17.5	7.6	135	73.0	173.2
60	M	28.0	24.4	28.5	6.1	4.2	18.0	18.8	8.8	165	81.3	184.3
$\bar{x}$	M	29.1	24.05	27.77	5.84	3.91	17.07	19.4	8.72	151.83	78.75	180.94
s	M	1.62	2.012	1.758	0.283	0.296	0.754	1.037	0.491	27.735	10.293	7.603

**APPENDIX F. SIMPLE EFFECT F-TESTS BY WRIST POSITION**

TABLE 23

90-deg Flexion ANOVA Summary Table

<i>Source</i>	<i>df</i>	<i>MS</i>	<i>F</i>	<i>p</i>
<i>Between Subject</i>				
Gender (G)	1	3450.81	2.64	0.1384
Subjects (S/G)	9	1304.88		
<i>Within Subject</i>				
Direction (D)	1	6184.84	12.66	0.0061
D x G	1	45.24	0.09	0.7678
D x S/G	9	488.37		
Total	21			

TABLE 24

## 75-deg Flexion Wrist Position ANOVA Summary Table

<i>Source</i>	<i>df</i>	<i>MS</i>	<i>F</i>	<i>p</i>
<i>Between Subject</i>				
Gender (G)	1	6706.53	7.04	0.109
Subjects (S/G)	46	952.72		
<i>Within Subject</i>				
Direction (D)	1	33347.76	131.12	0.0001
D x G	1	414.18	1.63	0.2083
D x S/G	46	254.33		
Total	95			

TABLE 25

## 60-deg Flexion Wrist Position ANOVA Summary Table

<i>Source</i>	<i>df</i>	<i>MS</i>	<i>F</i>	<i>p</i>
<i>Between Subject</i>				
Gender (G)	1	6301.04	10.25	0.0023
Subjects (S/G)	54	614.48		
<i>Within Subject</i>				
Direction (D)	1	12494.34	46.69	0.0001
D x G	1	432.77	1.62	0.2089
D x S/G	54	267.62		
Total	111			

TABLE 26

## 45-deg Flexion ANOVA Summary Table

<i>Source</i>	<i>df</i>	<i>MS</i>	<i>F</i>	<i>p</i>
<i>Between Subject</i>				
Gender (G)	1	11977.75	19.97	0.0001
Subjects (S/G)	58	599.74		
<i>Within Subject</i>				
Direction (D)	1	6862.86	43.38	0.0001
D x G	1	103.22	0.65	0.4222
D x S/G	58	158.22		
Total	119			

TABLE 27

## 30-deg Flexion Wrist Position ANOVA Summary Table

<i>Source</i>	<i>df</i>	<i>MS</i>	<i>F</i>	<i>p</i>
<i>Between Subject</i>				
Gender (G)	1	10255.83	15.73	0.0002
Subjects (S/G)	58	652.16		
<i>Within Subject</i>				
Direction (D)	1	6649.32	30.73	0.0001
D x G	1	10.66	0.05	0.8251
D x S/G	46	216.39		
Total	119			

TABLE 28

## 15-deg Flexion Wrist Position ANOVA Summary Table

<i>Source</i>	<i>df</i>	<i>MS</i>	<i>F</i>	<i>p</i>
<i>Between Subject</i>				
Gender (G)	1	10881.25	18.29	0.0001
Subjects (S/G)	58	594.99		
<i>Within Subject</i>				
Direction (D)	1	4144.13	26.74	0.0001
D x G	1	0.81	0.01	0.9426
D x S/G	58	154.99		
Total	119			

TABLE 29

## 0-deg (Neutral) Wrist Position ANOVA Summary Table

<i>Source</i>	<i>df</i>	<i>MS</i>	<i>F</i>	<i>p</i>
<i>Between Subject</i>				
Gender (G)	1	10461.47	18.11	0.0001
Subjects (S/G)	58	577.74		
<i>Within Subject</i>				
Direction (D)	1	2453.87	21.27	0.0001
D x G	1	24.87	0.22	0.6411
D x S/G	58	115.36		
Total	119			



TABLE 30

## 15-deg Extension Wrist Position ANOVA Summary Table

<i>Source</i>	<i>df</i>	<i>MS</i>	<i>F</i>	<i>p</i>
<i>Between Subject</i>				
Gender (G)	1	10818.24	21.29	0.0001
Subjects (S/G)	58	508.18		
<i>Within Subject</i>				
Direction (D)	1	2371.83	25.50	0.0001
D x G	1	180.96	1.95	0.1684
D x S/G	58	92.77		
Total	119			

TABLE 31

## 30-deg Extension ANOVA Summary Table

<i>Source</i>	<i>df</i>	<i>MS</i>	<i>F</i>	<i>p</i>
<i>Between Subject</i>				
Gender (G)	1	11659.19	23.11	0.0001
Subjects (S/G)	58	504.45		
<i>Within Subject</i>				
Direction (D)	1	894.18	8.31	0.0055
D x G	1	71.44	0.66	0.4184
D x S/G	58	107.65		
Total	119			

TABLE 32

## 45-deg Flexion Wrist Position ANOVA Summary Table

<i>Source</i>	<i>df</i>	<i>MS</i>	<i>F</i>	<i>p</i>
<i>Between Subject</i>				
Gender (G)	1	9450.59	19.41	0.0001
Subjects (S/G)	58	486.89		
<i>Within Subject</i>				
Direction (D)	1	967.93	14.98	0.0003
D x G	1	2.52	0.04	0.8442
D x S/G	58	64.59		
Total	119			

TABLE 33

## 60-deg Extension Wrist Position ANOVA Summary Table

<i>Source</i>	<i>df</i>	<i>MS</i>	<i>F</i>	<i>p</i>
<i>Between Subject</i>				
Gender (G)	1	5888.89	19.06	0.00001
Subjects (S/G)	58	303.50		
<i>Within Subject</i>				
Direction (D)	1	782.75	17.33	0.0001
D x G	1	4.11	0.09	0.7640
D x S/G	58	44.37		
Total	119			

TABLE 34

## 75-deg Extension Wrist Position ANOVA Summary Table

<i>Source</i>	<i>df</i>	<i>MS</i>	<i>F</i>	<i>p</i>
<i>Between Subject</i>				
Gender (G)	1	3451.08	12.52	0.008
Subjects (S/G)	58	275.62		
<i>Within Subject</i>				
Direction (D)	1	417.06	11.34	0.0014
D x G	1	203.32	5.53	0.224
D x S/G	58	36.79		
Total	119			

TABLE 35

90-deg Extension Wrist Position ANOVA Summary Table

<i>Source</i>	<i>df</i>	<i>MS</i>	<i>F</i>	<i>p</i>
<i>Between Subject</i>				
Gender (G)	1	3868.95	4.01	0.0541
Subjects (S/G)	31	965.66		
<i>Within Subject</i>				
Direction (D)	1	2609.53	23.63	0.0001
D x G	1	9.16	0.08	0.7752
D x S/G	31	110.45		
Total	65			

## VITA

M. Susan Hallbeck was born in Lexington, Kentucky on June 25, 1962. She received her B.S. in Industrial Engineering from Iowa State University in 1984, her M.S. in Industrial Engineering from Texas Tech University in 1985, and is completing her Ph.D. in Industrial Engineering at Virginia Polytechnic Institute and State University. She is currently employed as an assistant professor in the Industrial and Management Systems Engineering Department at the University of Nebraska - Lincoln.

*M. Susan Hallbeck*