

FOOD IN SEVENTEENTH-CENTURY TIDEWATER VIRGINIA:
A METHOD FOR STUDYING HISTORICAL CUISINES

by

Maryellen Spencer

Dissertation submitted to the Faculty of the
Virginia Polytechnic Institute and State University
in partial fulfillment of the requirements for the degree of
DOCTOR OF PHILOSOPHY
in
Human Nutrition and Foods

APPROVED:

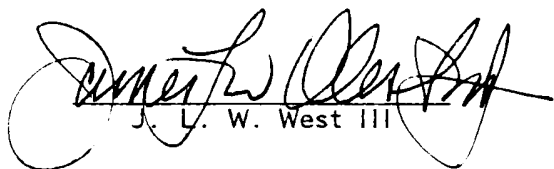

L. J. Harper, Chairman

J. A. Phillips

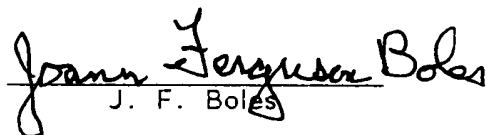
J. L. W. West III

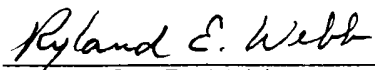
J. F. Boles

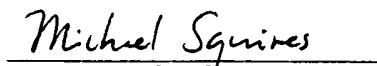
R. E. Webb

M. G. Squires

June, 1982

Blacksburg, Virginia

ACKNOWLEDGMENTS

Over five years ago, Laura Jane Harper, Dean Emeritus of the College of Home Economics at Virginia Tech, encouraged my plan for an unconventional doctoral program, a program emphasizing the humanistic study of food. Then she made the program possible, removing obstacles and creating opportunities, sharing her vision, insights, and energy. Other members of my advisory committee also consistently gave support, encouragement, and time. Jean Phillips shared her imaginative perspective on food science, her deft resourcefulness, and her cheerful good sense. Adding an important dimension to my program by introducing textual and bibliographical studies in literature, James L. W. West III helped me develop a disciplined base of research skills and also shepherded literary projects to fruition. Joann Boles generously shared her enthusiasm for historical research and her practical experience in studying artifacts; Ryland Webb contributed the helpful skepticism of a biochemist and his own kind interest. Throughout my writing of the dissertation, Michael Squires gave keen critical counsel, ameliorative editorial aid, and peremptory encouragement.

Special thanks are due the Virginia Research Center for Archaeology, a division of the Virginia Historical Landmarks Commission, for provision of important research materials; Curator Bly

Bogley introduced me to the scholarly land of historical archaeology, answered countless questions, and provided access to artifacts, a specialized library, and a rich store of unpublished manuscripts. Chief Park Historian James N. Haskett and Curator Susan Hanna provided access to artifacts at the National Colonial Historical Park, National Park Service, Jamestown. Also helpful in locating and providing research materials were Dorothy McCombs and other staff members at the Virginia Tech libraries; the Colonial Williamsburg Research Library; and the Virginia Historical Society.

For the visual presentation of findings, Susan Davis transformed rough sketches into an artist's fine drawings, and Raymond Spencer photographed the Jamestown artifacts. My parents, Mary and Robert Spencer, shared their home and comforts while I spent many weeks gathering data in Tidewater. Finally, I owe my present boss, S. J. Ritchey, Dean of the College of Home Economics, a large packet of gratitude for his interest and support which helped make completion of the research and dissertation a reasonable, pleasurable endeavor.

TABLE OF CONTENTS

Acknowledgments	ii
Preface	1
Section I. FRAMEWORK	
Chapter	
1. The Portrait of a Cuisine: Background and Problems	5
2. The Method: A Plan for Defining and Describing Historical Cuisines	15
3. The Historical Context	53
Seventeenth-Century Virginia	53
Virginia's English Gastronomic Heritage	84
Virginia's Aboriginal Cuisine	89
Section II. FINDINGS	
Introduction	100
Chapter	
4. The Food Supply	103
5. Facilities and Equipment	130
6. Cooks and Their Methods	210
7. Dining and Drinking	222
Section III. CONCLUSIONS	
Chapter	
8. The Cuisine	264
9. The Proven Pudding: An Evaluation of the Method	270

SELECTED BIBLIOGRAPHY	275
APPENDICES	
A. A Method for Studying Historical Cuisines: An Annotated Checklist	288
B. Selected Extracts from Published Primary Sources	311
C. Glossary	410
Vita	423
Abstract	425

PREFACE

Knowing how people eat—their foods, preparation styles, and dining customs—helps us understand how they live. Not merely a style of food preparation, a cuisine is the culinary and gastronomic profile of a culture, the physical and behavioral expression of a culture's social and aesthetic values. A cuisine has a dynamic relationship with its time, and historical cuisines also relate to our own time: an understanding of food in history better enables us to interpret and even influence current food styles and patterns.

Yet the researcher interested in historical cuisines faces a dilemma: how to conduct historical studies of the subject. Although we have methods for studying the chemical, nutritional, economic, and social aspects of food, we lack methods for studying historical cuisines or for defining the aesthetic and stylistic aspects of a cuisine. Most historical research centered on food has employed agricultural economics in relating food production data to a general nutritional status, while most research on food in culture has studied food habits with the objective of improving nutritional status. American food seems to have been especially neglected in the already scanty store of historical food studies, and almost all of the American studies have examined folk or ethnic food. Because so few studies of food history or of cookery styles have been conducted, we lack what might be termed a "body of knowledge." Food history has no orderly scholarly

arena, no discipline. One reason for the lack of systematic studies of food in history is an aversion among many scholars in food and nutrition to "cuisines," to the stylistic and aesthetic aspects which might seem merely decorative aspects of man's diet. Another reason is a lack of training among those professionals in humanistic disciplines. But an overriding reason for the absence of scholarly histories of cuisines is the temporal, transitory nature of a cuisine.

If we compare cuisines with related popular arts such as costume, textiles, and home furnishings, a distinction quickly emerges: costumes, textiles, and furnishings may survive as extant artifacts, but food does not. However humble or grand, a meal is prepared to be consumed. In no way can we study a meal of the past firsthand; in no way can we know with certainty what tastes, textures, and smells met our ancestors at the dinner table. Descriptions and pictures of a meal reveal no more about a dining experience than descriptions and pictures of a musical event bring us the sounds or the experience of listening.

Food in seventeenth-century Virginia serves well as a test subject for a historical method. Historians traditionally have neglected daily life and common people in studies of that period, concentrating instead on politics and the elite. More recently, historical archaeologists and scholars in material culture have begun investigating the realm of daily experience in which food figures importantly, but they have discovered little about the stylistic and aesthetic aspects of the cuisine.

This study begins to address those two problems: the need for a method for studying historical cuisines, and the unanswered questions about Virginia's early cuisine. Although the method developed and tested in this study proved complex and demanding, it also brought rewards. Working across disciplines and using three categories of research sources—artifacts, documents, and iconographic records—proved especially helpful in uncovering and sifting data. Much was revealed about the physical context of Virginia's seventeenth-century cuisine: the available foods, the cooking and dining equipage. Aesthetic values were explained to some extent, as were dining customs. But the absence of primary recipe books, the dearth of information about seventeenth-century women, and our general ignorance of daily life during that century hindered discovery of the activities relating to food—the techniques and procedures for preparing, cooking, storing, and serving food. Additional studies, new sources, and refined methods may begin to unlock even those mysteries.

Section I. FRAMEWORK

Chapter 1

THE PORTRAIT OF A CUISINE: BACKGROUND AND PROBLEMS

Writers examining the scholarly study of food in history and of food in culture talk a great deal about the need for a methodology but generally fail to propose or outline one. Of the books and articles reviewed while developing the method for this study, few related specifically to the study of a historical cuisine. To help future researchers move more quickly through that frequently fruitless investigation, the more significant publications are described in an annotated checklist in Appendix A.

An effective portrait of a historical cuisine should describe and define the food so vividly, and develop the surrounding physical and social context so richly, that we can hypothetically experience the food of the period. A description of Tidewater Virginia's cuisine in the seventeenth century should tell us what it was like to dine in early Jamestown, to breakfast at a farm on the Eastern Shore, and to feast at a plantation on the James River. We should have a sense of the setting of the meal, the physical appointments, and the style of service. We should know which foods were typical, which special; which foods were grown at home, which imported. We should have some sense of how the foods compared with their counterparts of today: whether meat was stringier or vegetables more flavorful or

bread denser. We should have an idea of the colors, textures, smells and tastes of the food.

Of all the publications reviewed in search of a method, the ones which best gave a sense of the attitudes and techniques appropriate to historical food studies were those of the historical archaeologist Ivor Noel Hume and the architectural historian Walter Horn. Both men share a persistent passion for the discovery of details of daily life in history. As chief archaeologist for Colonial Williamsburg, Noel Hume has done much to make the presentation of eighteenth-century life at Williamsburg both increasingly realistic and increasingly accurate. In an attack on the traditionally dry museum treatment of historical artifacts, he writes,

. . . I am not offended by the term "pots-and-pans history." Pots and pans invoke the idea of cooking, of smoke grasped by breezes and carried away over the trees and rooftops, creating aromatic smells to titillate the palate. And pots and pans have sounds of their own: a wooden spoon beating against the side, the clatter of crockery in the hands of a scullery maid. These and a dozen other lively images are instantly brought to mind—and *lively* is the key word, for these pots and pans are echoes from the life of the past.¹

In the preface to *Here Lies Virginia*, Noel Hume refuses to apologize for any lack of dusty reverence in his approach to Virginia's history and archaeology:

I do not agree that it is necessary for those of us who devote our lives to history or archaeology to hide behind a mask of erudite solemnity to prove that we treat our work

¹ "Material Culture with the Dirt on It: A Virginia Perspective," in *Material Culture and the Study of American Life*, ed. Ian M. G. Quimby (New York: W. W. Norton, 1975), p. 21.

seriously; nor do I believe that by "popularizing" it we are automatically guilty of lowering our standards. On the contrary, it can be argued that the only good reason for studying the people of the past is to introduce them to the public of today. If we make that introduction so dry and forbidding that nobody enjoys the experience, we have surely been wasting our time. If this heresy causes some of my colleagues to turn yellow at the edges, I can only urge them to read no further.²

While Noel Hume has unashamedly employed popular, even theatrical, communication techniques in his presentation to the public of eighteenth-century daily life, Walter Horn has produced an awesome academic study of medieval architecture and life unlikely to make his colleagues "turn yellow at the edges." Horn's publication with architect Ernest Born of *The Plan of St. Gall* celebrates the achievements of many years of work dedicated to defining and describing the daily life of a paradigmatic Carolingian monastery.³ Horn defines the monastic physical context: the buildings, rooms, workshops, gardens, and equipment. He sets forth the intellectual, religious, and social determinants of the environment. Looking at everything from baking and brewing to bathing, he applies imaginative logical reasoning to the evocation of daily life in its minutest detail.

The Horn-Born publication clearly and straightforwardly presents extensive and complex research findings, with many features helpful to scholars: an annotated bibliography, a glossary, and chronological tables. Horn, like Ivor and Audrey Noel Hume at Williamsburg, uses

² *Here Lies Virginia* (New York: Alfred A. Knopf, 1963), pp. viii-ix.

³ Walter Horn and Ernest Born, *The Plan of St. Gall*, 3 vols. (Berkeley: Univ. of California Press, 1979).

three distinct categories of research sources: artifacts, documents, and iconographic material. The use of such complementary types of sources allows a richer melding, confirming, and challenging of research findings than is possible with a single type of evidence.

Ivor Noel Hume has pointed out that while the historian studies documents and the anthropologist studies things, the historical archaeologist studies things in relation to documents in developing the case for historical findings.⁴ Most studies of food history have depended largely on documentary sources, frequently with an emphasis on statistical data. An English study by J. C. Drummond and Anne Wilbraham, and an American one by Richard Osborn Cummings, represent the more successful and respected of the quantitative studies of diet.⁵ Drummond and Wilbraham use economic and production data in the study of the English diet, and they give special attention to institutional diets and to the diets of social classes. In a historical study of the American diet, Cummings uses several kinds of statistical data: the per capita consumption of foods, the seasonal availability of foods, food budgets, the retail cost of calories, and food costs.

⁴ Ivor Noel Hume, *Historical Archaeology* (1969; rpt. New York: W. W. Norton, 1975), pp. 7-10.

⁵ J. C. Drummond and Anne Wilbraham, *The Englishman's Food*, rev. Dorothy Hollingsworth (London: Jonathan Cape, 1957); Richard Osborn Cummings, *The American and His Food*, rev. ed. (1941; rpt. New York: Arno Press, 1970).

In *Food and Drink in Britain*, C. Anne Wilson emphasizes the logical development of a cuisine and recounts a history of cookery rather than a history of diet.⁶ Like Jane Carson in her *Colonial Virginia Cookery*, Wilson uses cookbooks as a chief research source.⁷ Wilson's work is perhaps more successful than Carson's, for she uses archival cookbook collections primarily to define a pattern of development in cooking styles and techniques. Carson, on the other hand, uses British cookbooks, frequently of the late eighteenth or early nineteenth century, as evidence of foods and dishes characteristic of the colonial Virginian cuisine.

And therein lies a tangled problem in the use of cookbooks as a key to what people ate in colonial Virginia. Did the colonists have and use cookbooks? How many cooks could read? To what extent do cookbooks reflect the cuisine of the general population? Cookbooks might be accepted as reflection of a cuisine when we know, as with Mrs. Glasse's eighteenth-century cookbook or Mrs. Beeton's nineteenth-century tome, that the books were commonly available and commonly used.⁸ But in general cookbooks are best used only to

⁶ C. Anne Wilson, *Food and Drink in Britain* (London: Constable, 1973).

⁷ Jane Carson, *Colonial Virginia Cookery* (Williamsburg: Colonial Williamsburg, 1968).

⁸ Mrs. Hannah Glasse's *The Art of Cookery Made Plain and Easy* was first published in London in 1747. Mrs. Isabella Beeton's *The Book of Household Management* was published as a bound edition in London in 1861 after serial publication in twenty-four parts from 1859 through 1861. Written by middle-class housewives for middle-class housewives, the two books were the most important English cookbooks of their respective centuries; both appeared in numerous editions, and both had extensive sales.

illustrate or explain dishes and techniques evident from other documentary sources such as diaries and travelers' accounts, or to suggest how commodities mentioned in trade or agricultural records might have been used.

In "Historical Sources for American Traditional Cookery," Don Yoder discusses problems in cookery research and suggests values and problems in using historical materials.⁹ He identifies historical sources as printed texts (travelers' accounts, cookbooks, government reports, laws, newspapers, periodicals, literature, almanacs, broadsides, biographies and autobiographies, and local histories), manuscript sources and personal legal documents (wills, estate inventories, and personal papers), and iconographic sources (books and periodical literature, manuscript drawings and sketchbooks). Yoder's suggested historical sources coincide with those employed by Ivor and Audrey Noel Hume, except that the Noel Humes' reference point is always the archaeological artifact.¹⁰

Anthropologists and social scientists usually take a different approach from that of historians, frequently with a survey-type collection of data and a more structural approach to the analysis of data. They also frequently use a schematic rather than narrative form of presentation. Chang, Harper, and Mead have developed frameworks

⁹ Don Yoder, "Historical Sources for American Traditional Cookery: Examples from the Pennsylvania German Culture," *Pennsylvania Folklife*, 20, No. 3 (Spring 1971), pp. 16-29.

¹⁰ Ivor Noel Hume, *Historical Archaeology*, pp. 7-10. Also see Noel Hume publications in the Colonial Williamsburg Archaeology Series, listed in Section V of Appendix A.

of research questions which can serve to initiate definition of a historical cuisine.

The anthropologist Chang outlines an approach for what he describes as a descriptive history of food based on archaeological, textual, pictorial, and literary sources. He writes in his introduction to *Food in Chinese Culture*, "An anthropological approach to the study of food would be to isolate and identify the food variables, arrange these variables systematically, and explain why some of these variables go together or do not go together."¹¹ He briefly outlines common themes or categories of research questions for a study of Chinese food, but he notes that he and his co-authors did not use a single preconceived framework. Chang and his fellow scholars present narrative expositions of their conclusions without describing the research and analysis phases of their work, but their book is nonetheless an important beginning effort in the formulation of a disciplined approach to food history.

Harper has expanded and adapted Chang's ideas into a more complex framework of large and small variables for the study of food in culture.¹² Her larger variables include a catalog of basic foodstuffs; an analysis of food preparation; food presentation; organization of amounts, varieties, and styles of foods into meals;

¹¹ K. C. Chang, ed., *Food in Chinese Culture* (New Haven: Yale Univ. Press, 1977), p. 3.

¹² Laura Jane Harper, "A Possible Framework for Studying Food in Culture," unpublished paper, Virginia Polytechnic Institute and State University, 1980.

likes and dislikes; customs and rituals; beliefs; patterns of continuity and change; and the importance of food in the culture. Harper's smaller variables relate to social factors: social class, occupations, stages in life cycle, sex roles, festival occasions, and religion.

The 1945 "Manual for the Study of Food Habits" and a related 1960 publication by Margaret Mead propose data categories or classifications similar to the outlines used later by Chang and suggested by Harper.¹³ The "Manual" outlines seven categories of data which can be adapted for historical research: the food pattern, the social organization of food, the ideology of food, the induction of the new generation into the food pattern, material culture and the technology of food, food pathology, and the study of stability and change in the food pattern. Mead writes of the need for a code which would provide for a formal description of a people's dietary pattern, including these aspects of food: physiological sensory terms, chemical terms, nutritional terms, and cultural terms.

Several researchers have described or outlined methods of data collection for food studies, and some of their ideas can be used or adapted in historical food studies. Frank W. Moore, in "Methodologic Problems of Cross-Cultural Dietary Research," describes the Human Relations Area Files effort to collect and organize dietary data on pre-

¹³ Committee on Food Habits, "Manual for the Study of Food Habits," *National Research Bulletin 111* (Washington: National Research Council, National Academy of Sciences, 1945), pp. 31-47; Margaret Mead, *Food Habits Research: Problems of the 1960's* (Washington: National Research Council, National Academy of Sciences, 1964).

industrial societies, and he identifies as a problem in data collection the design of a coding sheet which would insure uniformity and accuracy and include needed information.¹⁴ Moore includes in his article sample data sheets for recording data on the food source, information pertaining to the society, and essay-type descriptive reports by ethnographers. Although his survey of a contemporary society attempted to include taste, odor, and texture as data classes, Moore was unable to devise a classification system for those properties. Moore also points out the general failing of the literature to report details of food preparation, the prestige value of food, and the acceptability of foods, although those topics are generally covered in questionnaires.

Helen S. Mitchell and Natalie F. Joffe have reported on a schematic analysis of the food habits of thirteen European countries and have presented their information in chart form.¹⁵ Mitchell and Joffe classify food according to the "basic seven" food groups and then according to a social matrix within which foods were identified for both rural and urban areas by source of food, kitchen and table equipment, cooking methods, meal patterns, food for special states or ages, and beliefs and attitudes toward food. The chart form of organization was intended to point up the strengths and weaknesses of

¹⁴ In *Journal of the American Dietetic Association*, 45 (Nov. 1964), 415-19.

¹⁵ "Food Patterns of Some European Countries: Background for Study Programs and Guidance of Relief Workers," *Journal of The American Dietetic Association*, 20 (Nov. 1944), 676-87.

a dietary pattern rather than to define a cuisine; the data on French and Italian food habits illustrate how this schematic method may give little or no sense of a cuisine or style of cooking.

No one seems to have solved the problems of classifying foods or of studying a food pattern in terms of aesthetic styles and sensory qualities. In one of the French *Annales* studies of food history, Jean-Claude Bonnet describes how in Diderot's *Encyclopedie* seventeenth-century learning turned its back on tastes and flavors which defied analysis, in a preoccupation with classifiable, definable information.¹⁶ We need finally to face that dilemma, learning to define and analyze the elusive but important experience of eating. First we need descriptive historical studies which identify and describe the components of cuisines. Then logically follow interpretive studies relating cuisines to physical, social, political, and aesthetic factors in their cultures. From that base of descriptive and interpretive studies, re-creative studies can suggest the experience of eating in earlier times, what it was like to sit down to dinner in another age.

¹⁶ Jean-Claude Bonnet, "The Culinary System in the *Encyclopedie*," In *Food and Drink in History*, Vol. 5, ed. Robert Forster and Orest Ranum, trans. Elborg Forster and Patricia M. Ranum (Baltimore: Johns Hopkins Univ. Press, 1979), pp. 139-65.

Chapter 2

THE METHOD: A PLAN FOR DEFINING AND DESCRIBING HISTORICAL CUISINES

The research design for defining a historical cuisine begins at the end: with an identification of what the researcher wants to discover, with an identification of the puzzle pieces to be assembled in a picture of a cuisine. After identifying the categories of information necessary for defining a cuisine, we identify possible sources for that information and follow with a systematic collection of data. We must also have an orderly system for analyzing and synthesizing the data, and with the synthesis we can finally arrive at the presentation of conclusions in defining and describing a historical cuisine.

Three types of research materials—artifacts, documents, and iconographic records—serve in this research design as mutually dependent components which supplement, challenge, and verify each other. The three components—artifacts, documents, iconographic records—interact like overlays or screens in printing; together they add up to more than the sum of their parts, and together they have coherence and authority impossible with only one kind of research source. Different kinds of data come from different types of sources: for example, archaeological artifacts can reveal what cooking utensils were present at specific sites; wills and estate inventories can provide documentary records of kitchen equipment owned by individuals at

specific times; and iconographic records may show the utensils in use in a kitchen setting. Findings from the three types of sources challenge and verify each other both by revealing inconsistencies, discrepancies, and contradictions in the data and by pointing up correlations and similarities among the evidence.¹

In employing the three components of artifacts, documents, and iconographic materials, this method for studying a historical cuisine involves five steps or stages:

- 1) development of a framework of research questions,
- 2) identification of historical sources,
- 3) data collection and evaluation,
- 4) analysis and synthesis of research data, and
- 5) presentation of results and conclusions: the definition and description of a cuisine within its historical context.

A criterion for responsible research is that it must be reproducible. Experimentalists frequently place major emphasis on method and results in reporting research, thus leaving the research data largely to speak for itself and the reader to at least mentally go through the research process. Historians, on the other hand, usually

¹ Historical archaeologists employ these three types of sources in an unusually coherent fashion. The publications by Ivor and Audrey Noel Hume cited in Appendix A, Section V, exemplify such an approach, and formal research reports by historical archaeologists reveal the methodological approach even more clearly. See, for example, Audrey Noel Hume, "A Group of Artifacts Recovered from an Eighteenth-Century Well in Williamsburg," in *Five Artifact Studies*, Colonial Williamsburg Colonial Papers in Archaeology, Vol. 1, ed. Ivor Noel Hume (Williamsburg: Colonial Williamsburg Foundation, 1973), pp. 1-24.

place major emphasis on a narration and justification of their research conclusions. Although historians may meticulously document their findings, they do not generally describe the process by which they arrive at those findings. In studying historical cuisines, however, we can have both an exposition of the research process and a vivid narration of its conclusions.

STEP 1. A FRAMEWORK OF RESEARCH QUESTIONS

To avoid excess verbiage, this outline is presented as topics rather than as stated questions.² Data on the topics provide the puzzle pieces, the fragments of a cuisine, which will be evaluated, analyzed, and assembled into a complete picture.

The first part of the outline, "The Large Historical Context," identifies the social, political, physical, and aesthetic influences of the culture on its cuisine. The second part of the outline, "The Cuisine," identifies both what foods and food preparations were possible and what foods and food preparations were actual in the culture. Investigation of available foods, cooking facilities, equipment, and skills tells us what was possible in the cuisine. For the actual

² Research questions posed by Chang and by Harper for the study of food in relation to culture were especially helpful in designing and compiling this framework of questions, or topics. See Chang, K. C., ed., *Food in Chinese Culture* (New Haven: Yale Univ. Press, 1977), 3-21; Laura Jane Harper, "A Possible Framework for Studying Food in Culture," unpublished paper, Virginia Polytechnic Institute and State University, 1980.

cuisine—the combination, manipulation, and transformation of foods into distinctive preparations, dishes, and meals—we need additional evidence, firsthand accounts of meals and eating experiences from sources such as diaries and travelers' accounts.

I. The Large Historical Context

THE PEOPLE: A SOCIAL CONTEXT

- Origin of the people
- Ethnic background
- Religion
- Education
- Trades and professions practiced
- Degree and distribution of wealth
- Urban/rural orientation
- Distribution of ages and sexes
- Family structure
- Social structure and stratification
- Kind, extent, and degree of communication
 - within a community or area, and
 - with the "outside"

THE POLITICAL CONTEXT

- Government
- Degree of political stability
- Degree of autonomy or independence of people
 - in making decisions relating to food

Restrictions on or regulations of trade,
 business, and agriculture
Influence of laws on daily life
Influence of laws on food supply and use
Trade
Economic structure and conditions

PHYSICAL CONTEXT

Typography
Climate
Proximity of water and forest
Quality of farmland
Natural resources
Seasonal variations in climate and resources
Rural/urban divisions; density of settlements
Extent and degree of agricultural development
Agricultural products
Degree of advancement in technology;
 distribution of technology
Transportation
Homes and architecture
Communication

AESTHETIC CONTEXT

Importance of aesthetics and beauty in daily life
Presence, extent, and kind of conscious art

(literature, painting, crafts, music)

Style in daily life: homes, clothing

II. The Cuisine

CATALOG OF AVAILABLE FOODS (INCLUDING IDENTIFICATION OF VARIETIES, FORMS, AND SENSORY PROPERTIES)

Meats and poultry

Fish and seafood

Grains

Vegetables

Fruits

Dairy products

Fats and oils

Beverages

Sweeteners

Condiments

Seasonings

FOOD PRODUCTION

Availability of wild or natural foods

(fish, game, nuts, fruits)

Home production (gardens, orchards,

livestock, dairy, bees, poultry)

Purchase or trade within community

Commercial agriculture

Imports and exports

Seasonal availability

FOOD CHOICES AND PREFERENCES

Relative abundance and importance of
individual foods

Relative preference for individual foods

Influence of cost and economic factors in
availability and use of foods

PHYSICAL FACILITIES FOR FOOD PREPARATION AND STORAGE

Kinds of kitchens or places for food preparation

Special rooms or buildings (dairy, smoke house,
still room, pantry)

Fires, stoves, ovens

Fuel used; availability of fuel

Utensils, tools, containers

Storage facilities; ability to control temperature
and quality of food through storage

COOKS AND FOOD-PREPARERS

Persons who prepared food

Training and background of preparer

Status of preparer (servant, slave, family
member, tradesperson)

Amount of time devoted to food production,
preparation, and preservation

Food preparation skills and techniques:

degree of sophistication and variability
The ways skills were taught or transmitted
within household and community
Value placed on skill in food preparation

FOOD PREPARATION

Recipes and procedures
Descriptions of preparation: how food
manipulated, cooked, or transformed
Extent and kind of transformation of food
in food preparation and cooking
How tools, ovens, etc., used
Effect of preparation techniques on nature
of cuisine

FOOD STORAGE

Kinds of foods stored
Place and manner of food storage
Length of time of storage of foods
Relation of storage techniques to season, weather,
geographic or urban/rural location, and
kind of household
Effect of storage techniques on nature of cuisine

FOOD PRESERVATION

Kinds of foods preserved
Techniques of preservation

Quantities of foods preserved

Length of time preserved foods stored

Use of preserved foods

Effect of preservation methods on nature of cuisine

FEEDING PATTERN (FOOD HABITS)

Foods offered at standard meals and on
special occasions

Balance of kinds and amounts of food
(starches or grains, protein foods,
fruits, etc.)

Amounts of foods consumed

Caloric pattern

Influence of food costs on food choice and use

Feeding of children, the elderly, and ill persons

Degree of preoccupation with food and eating

Frequency of use of specific foods

Degree of choice in use and combination of foods

FOOD STYLE AND AESTHETICS

Importance of aesthetic qualities of foods:

color, texture, shape

Inventiveness in use and preparation of food

Variety in preparation and in combinations of foods

Characteristic flavors and textures

Importance of meals as entertainment or

pleasurable experiences

DINING: PRESENTATION AND SERVING OF FOOD

Occasions for serving of food

Meal kinds and times

Physical setting (place in home)

Eating and serving wares

Person serving food and role in household

Combinations and amounts of food served

Etiquette and dining customs

Special foods and customs for holidays, festivals,

rituals, celebrations, and family occasions

(weddings, funerals)

Variation of presentation and service of food

with economic and social status

CULINARY HERITAGE

Traditional foods

Traditional preparation of foods

Traditional meals and combinations of foods

BELIEFS AND VALUES

Knowledge or beliefs about nutrition

Taboos and restrictions relating to food

Prejudices regarding food

Influence of religion on attitudes

toward food

IDEOLOGY OF FOOD

Value placed on food, food preparation, and
 food service in the culture

Semantics associated with food

Symbolism associated with food

Relation of food to ceremony

STEP 2. IDENTIFICATION OF HISTORICAL SOURCES

Sources for the study of historical cuisines vary considerably with time period and type of culture. We need to begin by considering every possible type of primary historical source if we wish to omit no available source. Primary historical sources fall into three categories:

- 1) artifacts relating to food production, preparation, and service,
- 2) primary documentary records, including both printed and manuscript sources, and
- 3) iconographic or pictorial records.

Repositories for historical sources also vary with the culture and with the time period, but they include museums, historical societies, libraries, research and antiquarian centers, government agencies (park services, landmark commissions), and artifact and manuscript collections at universities. One must usually be quite persistent in

asking for materials relating to food. More often than not, my request for materials relating to seventeenth-century food brings puzzled or tentative replies of "Oh, we don't have many cookbooks, and none from that period," because even librarians and curators tend to think of food only in terms of cookbooks. So one must be ready with requests for specific materials: trade records, diaries, botanical books, cooking equipment, or whatever.

Sources for Artifacts

Archaeological artifacts provide in historical studies some of the most reliable clues to the foods, containers, equipment, and utensils which were present and available. In modern archaeological research artifacts are related to their "archaeological context"; both artifacts and strata are dated, and note is made of the room or setting within which artifacts and groups of artifacts are found. Some archaeologists specialize in faunal and floral analyses, and the analysis of archaeological plant and animal remains tells us which plant and animal species were present at sites and even how they were used or cooked.³

³ See, for example, Audrey Noel Hume, *Food*, Colonial Williamsburg Archaeological Series No. 9 (Williamsburg, Virginia: Colonial Williamsburg Foundation, 1978); Henry M. Miller, "Pettus and Utopia: A Comparison of the Faunal Remains from Two Late Seventeenth Century Virginia Households," paper presented at the Conference on Historic Sites Archaeology, Winston Salem, N. C., 1978 (manuscript at Virginia Research Center for Archaeology, Williamsburg).

Archaeological artifacts possess both limitations and advantages. Artifacts relating to cuisines include primarily metal and ceramic items; wood, leather, baskets, and fabric rarely survive underground. Another limitation is the very reason the artifacts came to be buried: archaeological artifacts are usually objects which were lost, broken, or discarded. Thus coarse pottery and brittle iron may appear in misleadingly disproportionate quantities simply because they broke readily and were easily replaced, while more durable and more cherished pewter and fine porcelain may appear infrequently. Moreover, archaeological artifacts usually appear as fragments, as mysterious portions of an unknown whole. These esoteric fragments make the food researcher dependent upon the reports and helpful guidance of archaeologists for identification of artifacts, but they can also provoke the researcher into a diligent effort to gain his own comfortable familiarity with the discarded objects of the past.

One of the more pleasant aspects of studying archaeological artifacts is the freedom in most collections to handle the artifacts: to feel the weight and balance of knives, to feel the rough texture of coarse pottery or the glassy smoothness of porcelain (wearing gloves or otherwise complying with the curator's directions, of course). If one is possessed of an eager and ready imagination, handling the artifacts can help give one an awareness and "feel" of what it might have been like to live with those things.

While archaeological artifacts usually represent trash, museum artifacts frequently represent treasures. Although folk and daily-life museums and exhibits have gained some prominence in recent years, artifacts in most museum collections are likely to be valuable or particularly fine objects with special aesthetic appeal, not the more common and ordinary things of daily life.

Although museum artifacts lack the complex physical context of archaeological artifacts which come from studies using modern research methods, they offer other values. They may possess a pedigree, a neatly documented history which reveals who made them, when and where they were made, and who owned them. We may also have documentary information on the use of museum objects. Museum artifacts can have special value as reference or comparison objects in relation to archaeological artifacts, with the helpful bonus of the ready availability of photographs and documentation in exhibition catalogs and museum records.

Artifacts for study in relation to historical cuisines include all objects relating to food storage, preservation, preparation, and service—ceramic, glass, metal, and wood, as well as leather and fabric. Pertinent artifacts also include items relating to dairy operations, butchering, fishing, and beekeeping; except in primitive cultures the researcher might stop short at farm tools and agricultural implements, for they become another world and another study entirely.

Documentary Sources

Primary documentary sources for studying historical cuisines include both printed and archival (manuscript) materials.⁴ Since the sources may vary considerably with the time and place under study, one might look for sources from two bases:

- 1) a search for the "usual" sources known to supply information about food and cookery, such as contemporary cookbooks as a clue to techniques of food preparation and diaries as a revelation of personal experiences in daily life; and
- 2) a survey of all the available documentary and textual sources of the culture, and examination of those sources for oblique or unexpected references to food; serendipitous references may be as unexpected as descriptions of food preparation included in court testimony for an adultery trial.

In cases where scholars have already given considerable attention to the history of a culture, primary documentary sources normally available only as manuscripts may be available in printed editions; these can range from edited diaries to trade records to transcriptions of court records. Printed sources are usually much easier to use than are manuscript sources, but a few caveats are in order. Printed or transcribed documentary records may contain both trivial and major

⁴ Don Yoder provides a helpful introduction to some of these sources in "Historical Sources For American Traditional Cookery: Examples from the Pennsylvania German Culture," *Pennsylvania Folklife*, 20, No. 3 (Spring 1971), pp. 16-29.

errors, especially if the information included in the records has an esoteric or specialized nature beyond the ken of the editor. In handwritten transcriptions of estate inventories in seventeenth-century court records, I have found errors which apparently occurred when the transcriber misread the almost-illegible letters in a word unfamiliar to him. On the other hand, printed documents edited by experienced scholars such as Susie Ames, Louis B. Wright, and David Quinn (cited later in this study) are likely to be superior to the readings of less accomplished scholars, and these scholarly editions also usually provide helpful notes. A common-sense approach then can be to survey first the printed editions of records and then to go to the original manuscript to verify anything of suspicious, substantial, or critical significance in the research.

PRINTED SOURCES

Cookbooks and "ladies' manuals"
 Books on farming, husbandry, etc.
 Trade and shipping records
 Agricultural records
 Government records (laws and judgments relating
 to food, agriculture, trade)
 Journalists' accounts
 Histories, especially local histories
 Published diaries, journals, correspondence,
 travelers' accounts
 Biographies and autobiographies

Literature: novels, poetry, songs

Newspapers and periodical literature

Catalogs and advertisements for cooking equipment
and table wares

Broadsides

Almanacs

MANUSCRIPT SOURCES

Manuscript cookbooks and recipe collections

Court records: wills, inventories, judgments

Personal legal documents

Personal and commercial accounts, ledgers

Letters, diaries, journals

Iconographic Sources

Important clues as to what people ate, how they grew and prepared their food, and how they served their meals may appear either conspicuously or inconspicuously in book illustrations, family sketches or photographs, and paintings. Archaeological and museum artifacts can be matched with similar or identical items in pictorial records, and in the pictorial records the items may be shown in use or at least within a kitchen or dining context; these correlations are called "comparatives." Iconographic materials can offer the advantages of dating and placing objects, as well as of identifying them.

ICONOGRAPHIC SOURCES

Illustrations in books, periodical literature,
catalogs

Paintings and drawings (household, genre and dining
scenes; still lifes; country and farm scenes)

Manuscript drawings and sketchbooks

Maps

Scenes and still lifes on ceramics and fabrics;
decorations on wood and metal

STEP 3. DATA COLLECTION AND EVALUATION

When determining an appropriate method or procedure for collecting data in the study of a historical cuisine, a return to the original research questions helps bring focus to a potentially unwieldy dilemma: where in a perhaps chaotic mass of research materials lie the bits and pieces of information which will define and describe a historical cuisine, and how can those bits and pieces be extracted from the mass in an orderly and efficient fashion? Since available research sources vary in the type of data they provide, the nature of the source and its information also determine the specific method employed for collecting data. A researcher overwhelmed by a mass of material might begin to impose order on chaos by asking, "What data from this material answer my research questions, and which questions do they address?"

Data from Artifacts

An overriding objective in recording data from artifacts such as cooking utensils is to gather and preserve everything one might need to know about the objects, to preserve an image and description complete enough to allow study of the artifacts without their physical presence, without opportunity for additional visits to the artifact collections.⁵ Photographs of significant artifacts help immensely both in the study of artifacts and in the presentation of conclusions. Black and white prints are practical for publications; color slides can be used for the study of artifacts as well as for the illustration of talks and other presentations of research findings. Sometimes one can obtain photographs from the holders of collections; sometimes do-it-yourself photography is in order. For small artifacts and fragments (knives, collander fragments) tracings sometimes can serve the purpose of photographs, as can archaeologists' precise drawings of artifacts.

For collecting information about artifacts, I devised a data form illustrated in Figure 1. Data include identification of collection and location of artifact within the collection, artifact number where used, site name and number, artifact date, archaeological date, measurements, description, photo number (either mine or the

⁵ Ivor Noel Hume includes a helpful and detailed record-keeping guide for archaeologists in his *Historical Archaeology* (1968; rpt. New York: W. W. Norton, 1975), pp. 194-256.

ARTIFACT	ARTIFACT NUMBER	PHOTO NO.
COLLECTION	ARCHAEOLOGICAL CONTEXT	
DATE OF ARTIFACT	SITE NO.	
SITE		
DIMENSIONS		
DESCRIPTION	PHOTO	
REFERENCES		

Figure 1. Data collection form for artifacts

collection's), and references. A contact print of a black and white photographic negative can be affixed for visual record; a tracing or drawing can also be included. With museum artifacts one simply omits inapplicable data items. The data collection form was designed to fit within the border of a Unisort analysis card (see Figure 2), thus providing flexibility in later sorting and analysis. To differentiate artifacts studied firsthand from those studied secondhand, I used forms printed on pale green paper for artifacts I personally examined and forms printed on pink paper for artifacts described and illustrated in publications.

Researchers lacking specialized connoisseurship and curatorial skills pertaining to food-related artifacts must depend greatly on the identifications and evaluations of experts in archaeology, ceramics, and other specializations.⁶ But an "outside" researcher must learn to recognize reliable and unreliable scholarship in matters of connoisseurship and curatorship and must learn a fair amount about artifacts before he can understand their uses and their places within the context of a culture. One cannot blindly accept information from catalog cards or from the analyses of other researchers, however

⁶ E. McClung Fleming, in "Artifact Study: A Proposed Model," *Winterthur Portfolio* 9, ed. Ian M. G. Quimby (Charlottesville, Va.: Univ. Press of Virginia, 1974), p. 157, identifies connoisseurship as "the trained eye and knowing touch matured by the special kind of artifact expertise resulting from extensive experience in examining and comparing objects," and notes that "the findings are interpreted by a well-stocked memory bank of precise images. . . ." He defines the skills of the curator as those of "the cataloging, care, conservation, exhibition of objects, and scientific examination."

expert. Sometimes curator's catalog cards do not indeed refer to artifacts with the corresponding catalog numbers. Labels can be switched about; mistakes in identification or dating can be perpetuated and compounded. In studying the artifacts of a specific time and place, the researcher should become familiar with the subtleties of their characteristic materials, finishes, shapes, and uses, thus developing a knowledgeable context of experience within which he can critically study and relate the artifacts encountered in collections. The shapes of seventeenth-century wine bottles and spoons, for instance, are clues to their dates. And while slipware and delftware may be characteristic of seventeenth-century artifacts from Virginia, creamware unmistakably belongs to the eighteenth century—as do European tea cups in a culture tea-less until the very end of the seventeenth century.

Data from Manuscripts and Documents

The method used in collecting data from manuscripts and documents must logically vary with the specificity and nature of the research question and with the nature of the information provided by the manuscripts and documents. And, as with artifacts, manuscripts and unpublished documents may be found more frequently in remote collections than in one's home library; thus one should collect data carefully and completely, knowing a return visit to the collection may be impractical.

If the researcher does not know exactly what information he needs at the time he encounters unexpected documents such as letters or accounts in a manuscript collection, the sensible procedure is simply to obtain photocopies of the manuscripts or to transcribe them for later study. But if a researcher needs specific data from masses of public records—for instance, amounts of sugar or spices shipped by merchants in certain years—he needs to record that data in a systematic and efficient fashion, perhaps on specially designed forms or collection cards. My practice is to obtain photocopies of manuscripts and documents whenever possible and practical, to transcribe documents or record data of a generalized nature on Unisort analysis cards (for flexibility in later analysis), and to record specific data from manuscripts on specially designed forms when appropriate to the demands of the planned analysis. Regardless of the collection method employed, complete documentary or bibliographic information must be recorded for manuscripts and documents: identification of author and manuscript, location of collection, location of manuscript within collection, any identifying numbers, and dates.⁷

Researchers who study manuscripts and other unpublished materials may encounter meticulously dated and verified documents which have been given expert curatorial attention; they may also encounter unsorted jumbles of miscellaneous and even dubious

⁷ Professional decorum and the responsibilities of researchers who use manuscripts are outlined by James Thorpe in *The Use of Manuscripts in Literary Research* (New York: Modern Language Association of America, 1974).

materials. These researchers, like the scholar confronting artifacts, must acquire knowledge and gain experience before they can evaluate manuscript materials as research sources. Basic evaluatory tools include a knowledge of the historical context, familiarity with the names of places and persons of the period, familiarity with the language and even handwriting of the time, and a clear sense of chronology and evolution in telltale and pervasive factors such as trade, demography, and technology.

The researcher in historical cuisines often has a special affection for manuscript cookbooks and recipe collections (alas, we have none from seventeenth-century Virginia). Manuscript cookbooks can present scholarly challenges quite apart from deciphering and understanding the recipes. Who wrote the manuscript, when, and where? Where did the author fit in the social, economic, and geographic framework of the time? Are the recipes typical or idiosyncratic? Printed cookbooks also require relentless scrutiny for reliability and appropriateness as research sources, and the questions applied to manuscript cookbooks should also be applied in the evaluation of printed cookbooks.

Printed documents and primary scholarly writings may offer information and data which equal or even surpass in importance the offerings of manuscript materials. Data from printed sources can be recorded on special forms when appropriate; sometimes the common note card systems work well: information and ideas on key topics are

collected along with documentary references, with an individual card for each topic or idea providing for later sorting and compiling.⁸

Data from Iconographic Materials

Iconographic materials for studying historical cuisines may be the most difficult research materials to locate and the easiest from which to collect and record data. Photographs of paintings and drawings—both of the whole and of pertinent details—can be used in the study and analysis of data as well as in the presentation of findings. Color photographs or slides are useful for study and analysis, and for illustration of presentations, while black and white photographs may be more practical for publication. Museums will generally supply, for publication, photographs of paintings and drawings in their collections. Illustrations in books, catalogs, and other printed materials also need to be photographed for publication, but photocopies will often meet the needs of study and analysis.

Documentary data to be recorded for paintings and drawings include artist, name generally given to the work, medium, size, collection, location of collection, and references. When located in printed materials, illustrations should be documented with bibliographical data in addition to identification of artist and

⁸ For helpful discussions of note card techniques, see Richard D. Altick, *The Art of Literary Research*, rev. ed. (New York: W. W. Norton, 1963), pp. 189-99, and Jacques Barzun and Henry F. Graff, *The Modern Researcher* (New York: Harcourt, Brace, 1957), pp. 24-31. Both works explain the scholarly use of historical documents and library materials.

illustration: author and title of work in which included; place, publisher, and date; and page or plate number.

STEP 4. ANALYSIS AND SYNTHESIS OF RESEARCH DATA

In the analysis and synthesis of data describing a historical cuisine, the researcher may face an overwhelming mass of disorderly gleanings. Order may be most quickly achieved by returning to the research questions and asking these questions:

- 1) What data relate most directly to the research questions? (If interesting data fail to relate to the research questions, exercise scholarly discipline and put them aside.)
- 2) What are the limitations of the data? What information do they fail to provide?
- 3) What interpretations of the data are necessary before they can be analyzed? (Is terminology archaic or inconsistent? Do terms or weights or monetary values need to be defined?)
- 4) What kinds of information might the data provide once they are organized and analyzed?
- 5) What treatment or view of the data will transform them into useful conclusions? (Is a quantitative analysis appropriate? Are chronology, geographic location, or demographic factors important?)

Analysis of Artifacts

The analysis of artifacts addresses three questions: what vessels, utensils, and equipment were available for cooking and dining; how they were used; and how they affected the character of the cuisine. In their analyses, archaeologists and museum curators generally emphasize the physical characteristics of artifacts, with an objective of precise identification and dating. The researcher studying cuisines, however, uses artifacts as clues to the nature and treatment of food, and must resist temptations to study the artifacts themselves instead of their presence and usage.

Two types of analyses by archaeologists contribute to studies of food patterns. A quantitative analysis of artifact assemblages can reveal patterns in function, material, and source of artifacts, as well as reveal the socio-economic status of households.⁹ Analyses of faunal and floral remains in archaeological studies both identify species of animals and plants which may have served as food and use quantitative data to reveal patterns of food availability.¹⁰

⁹ See, for example, Merry Abbitt Outlaw, Beverly A. Bogley, and Alain C. Outlaw, "Rich Man, Poor Man: Status Definition in Two Seventeenth Century Ceramic Assemblages from Kingsmill," paper presented to the Society for Historical Archaeology, Annual Conference, Ottawa, Canada, 1977 (manuscript at Virginia Research Center for Archaeology, Williamsburg).

¹⁰ See, for example, Michael B. Barber and Alain C. Outlaw, "Faunal Remains," in "An Interim Report, Governor's Land Archaeological District Excavations: The 1976 Season," Alain C. Outlaw, 1978 (manuscript at Virginia Research Center for Archaeology, Williamsburg), pp. 75-86. This report also includes analyses of ceramic artifacts according to foodways function, pp. 66-68 and 154.

In this study of food in seventeenth-century Virginia, I have correlated artifacts with documentary and iconographic evidence, especially with data from estate inventories and with objects depicted in paintings. For identification and dating of artifacts, I have depended largely upon archaeologists' analyses.

Analysis of Documentary Data

Primary documentary sources relating to food in seventeenth-century Virginia are limited to court records, accounts of adventurers and travelers, and correspondence. These documents, although they say little about food preparation, give much information about the foods available and the vessels, utensils, and equipment available for cooking and dining. The travelers' accounts and correspondence also give one kind of information not provided by artifacts—value judgments. Travelers, in their interest in the unusual and exotic, often commented on the quality and character of food.

Handwriting and language complicate the study of seventeenth-century documents. Court records and other manuscripts in Virginia were scribed in what might be termed a not-so-fine provincial hand. Although some of the handwriting is remarkably clear, much of it appears at first to be incorrigibly illegible—as well as sometimes smeared, faded, or spilling over the ragged edges of torn and damaged pages. Spelling is inventively inconsistent, as is orthography: the seventeenth-century provincial hand had at its

disposal a variety of confusing ways of forming letters of the alphabet, many of them far removed from the way we form letters today. (For an example of orthography in court records, see Plate 1.) Alarming as the suggestion may seem, the best way to learn to read seventeenth-century handwriting is to learn to write it; the next best way to learn to read the handwriting is to read a lot of it—familiarity helps.¹¹

Probate inventories, or appraisals of a person's property after his death, were used both in assessment for taxes and in resolution of debts. Vessels, utensils, and equipment used in cooking and food preparation were listed along with furniture, wearing apparel, and tools. Servants, slaves, and livestock were also listed, as well as tobacco and corn; food items such as salt and dried meat were occasionally included.¹² Inventories of planters' stores indicate what household goods were imported by planters for their own use or for sale to neighbors. Possessions were sometimes listed according to the rooms or buildings in which appraisers found them; information about the existence of rooms and outbuildings reveal something of the

¹¹ For help in deciphering seventeenth-century handwriting, see Kent P. Bailey and Ransom B. True, *A Guide to Seventeenth-Century Virginia Court Handwriting*, Research Bulletin 1 (Richmond: Association for the Preservation of Virginia Antiquities, 1980).

¹² Carr and Menard explain that corn in excess of three barrels was included in inventories because three barrels of corn was considered the consumption allowance for one man for one year. See Lois Green Carr and Russell R. Menard, "Immigration and Opportunity: The Freedman in Early Colonial Maryland," in *The Chesapeake in the Seventeenth Century*, ed. Thad W. Tate and David L. Ammerman (New York: W. W. Norton, 1979), pp. 206-242.

physical context of the home and its facilities for food preparation.

Some studies of probate inventories have concentrated on transcriptions which list possessions; these transcriptions provide sometimes detailed identifications useful in studies of home furnishings, clothing, and food.¹³ Other studies have examined inventories for evidence of a category of possessions. In his study of ceramics at Plymouth, Chace listed inventory entries with the terms *earthen* and *stone*.¹⁴ At St. Mary's City Commission researchers have used statistical analyses of Maryland estate inventories in studies of wealth and status.¹⁵ Socio-economic studies show some of the possibilities in statistical analyses of estate inventories; they also identify some of the biases and limitations. Menard *et al.* point out that the inventories cannot be considered representative of the living population, that estates of the very rich and the very poor may be inventoried less frequently than those of middling planters, and that the inventories disproportionately represent older property owners.¹⁶ Main also notes problems of bias, and attributes the long neglect of probate records as a research source to "the fact that probate records are rarely

¹³ For an example of an English study emphasizing transcriptions, see *The Goods and Chattels of Our Forefathers*, ed. John S. Moore, Frampton Cotterell and District Historical Studies, I (London: Phillimore, 1976).

¹⁴ Paul G. Chace, "Ceramics in Plymouth Colony, An Analysis of Estate Inventories 1631-1675," *Occasional Papers in Old Colony Studies*, No. 3 (Dec. 1972), 1-12.

¹⁵ See, for example, Russell R. Menard, P. M. G. Harris, and Lois Green Carr, "Opportunity and Inequality: The Distribution of Wealth on the Lower Western Shore of Maryland, 1638-1705," *Maryland Historical Magazine*, 69 (1974), 169-84.

¹⁶ Menard *et al.*, "Opportunity and Inequality," p. 170.

susceptible of direct, unqualified use."¹⁷ She observes that most probated decedents were older, wealthier males, while the poorest class—young unmarried males and non-heads-of-households—are unlikely to be represented proportionately in probate records.

In addition to recognizing the biased populations represented in probate inventories, the researcher examining possessions related to food must recognize another bias: the inclusion of possessions on the basis of monetary rather than practical value. The emphasis on monetary value results in often meticulous itemization of metal objects (iron pots, brass kettles, pewter dishes, silver spoons), usually only occasional and casual reference to earthenware (as in an unitemized "parcel of earthenware"), and usually no mention of financially insignificant wooden spoons and bowls.

In addition to recognizing the unrepresentative nature of probate records, researchers must deal with problems of language and terminology. Words whose twentieth-century meanings we take for granted may have had entirely different meanings three hundred years ago and may have had alternate meanings in the earlier era. For instance, we today call a frying pan with a cover a *skillet*, whereas in the seventeenth-century a skillet was a saucepan with a long handle and legs. A *crow* might have been a trivet or a tool; since *crows* or *frows* in Virginia inventories generally appear listed with tools, I

¹⁷ Gloria L. Main, "Probate Records as a Source for Early American History," *William and Mary Quarterly*, 3d Ser., 32 (Jan. 1975), 89-99.

concluded they were more likely outdoor tools than cooking equipment.

Useful for defining archaic words are dictionaries or encyclopedias of the period. Researchers studying objects and artifacts of the seventeenth century find Randle Holme's *The Academy of Armory* especially valuable because it provides drawings of objects (including all sorts of things used in the production, preparation, cooking, and consumption of food) together with their names and descriptions and sometimes with explanations of their uses.¹⁸ Although dictionaries published before Samuel Johnson's pioneering eighteenth-century lexicon were simply lists of words, *The Oxford English Dictionary* serves today as a guide to archaic definitions by showing the history and evolution of a word's uses and meanings.

Documentary data pertaining to food in seventeenth-century Virginia fall into two main categories: itemization of vessels, utensils, and equipment (and some foods) in estate inventories; and mention of foods available (species of fruits and vegetables, animals and seafood) in adventurers' and travelers' accounts and in correspondence. With data from estate inventories I made a simple quantitative analysis of incidence, or number of mentions, within ten-year time periods. In correspondence and records of business transactions I identified

¹⁸ Holmes' manuscript, dated 1649, is held at the British Museum as Harley MSS 1920-2180. At Chester in 1688 Holme published part of the work (through Book 3, chap. 13) as *The Academy of Armory, or a Storehouse of Armory and Blazon*. A second volume (Book 3, chap. 14, through Book 4, chap. 13), includes most of the references to household objects and was published in 1905 by the Roxburghe Club in London, edited by I. H. Jeayes.

evidence of imported and purchased foods, and their sources. Once the documentary data were organized and subjected to those simple analyses, I attempted to further define the vessels, utensils, and equipment by comparison with contemporary pictures, documentary descriptions, and artifacts, and to further define the food animals and plants through contemporary descriptions.

Analysis of Iconographic Data

Except for a few illustrations of Indians growing, catching, preparing, and eating food, we have no pictures of food in seventeenth-century Virginia. With this type of primary iconographic data, analysis consists of identification and interpretation:

- 1) What is the food or object pictured?
- 2) What is the process or procedure which is depicted?
- 3) What is the context for the thing or activity depicted?

In this study, analysis of iconographic data consists mainly of comparing pictures with artifacts and with documentary data.

Synthesis of data

Synthesis of data on a historical cuisine involves organizing the analyzed findings in response to the guiding research questions. Findings may also need to be qualified; some may be strong and convincing, while others may be questionable or weak. The absence of findings for certain research questions needs to be identified, and

the effect of that lack of information on the completeness and clarity of the portrait of the cuisine needs to be explained.

The researcher must work on several levels while synthesizing research findings. Identification of foods, vessels, utensils, equipment, procedures and techniques used with food, and dining customs should generally come entirely from primary data. Information from secondary sources can serve to explain and interpret primary data. And information about the historical context informs the researcher's judgment and interpretation. During the complex process of analyzing and synthesizing research findings, concentration on primary data helps focus the work, avoid distracting tangents, and increase both accuracy and efficiency.

STEP 5. PRESENTATION OF RESULTS AND CONCLUSIONS

The final step of a study defining and describing a historical cuisine—the presentation of results and conclusions—presents the researcher with choices and dilemmas. What presentation format and components will serve the study clearly, efficiently, and appropriately?

I have chosen to present findings in a narrative style and in a format which echoes the framework of the research questions. Rather than present the findings in a pattern reflective of the sources and the procedures with which they were located and analyzed, I have let the framework of the research questions provide the structure.

My format includes first the historical context: the social, political, physical, and aesthetic factors which determined and influenced the cuisine. Because of the peculiar nature of seventeenth-century Virginia—the colony of an advanced nation, in an aboriginal environment—I have supplemented the exposition of the general historical context with discussions of the aboriginal cuisine and of the English gastronomic heritage.

Discussion of the cuisine, or of the possibilities for a cuisine, focuses first on its physical base: the available foods and the facilities and equipment for handling or transforming food. Then follow the human factors: the cooks and their skills, and the cooking and food processing methods possible both in terms of skill and in terms of physical facilities and equipment. A discussion of dining and drinking addresses the social, aesthetic, and ideological aspect of the cuisine: the food habits, values, and styles. The presentation then concludes with a summary, or overview of the cuisine—the portrait.

Whenever practical, I have used photographs, drawings, and diagrams to present findings graphically. A glossary helps explain archaic or obscure terms. In another appendix a chronological ordering of selected extracts from published primary sources shows the patterns which emerge when pertinent passages are isolated and organized.

Strategies and techniques for presentation, like strategies and techniques for data collection and analysis, must necessarily vary with

the cuisine under study, with the inevitable vagaries of sources and findings. A method for studying historical cuisines can never be fixed or dogmatic; it must be guided more by broad principles than by minute procedures. Difficult, demanding, and inevitably inefficient, historical research offers rewards much like those of preparing an elaborate banquet: the joys of thoughtful planning, judicious shopping, tedious paring, solicitous basting, and hospitable serving.

Chapter 3

THE HISTORICAL CONTEXT

An understanding of a cuisine's historical context helps interpret research findings and prevent false assumptions about that cuisine. Because the daily life and social history of seventeenth-century Virginia remain shrouded in mystery and fraught with misconceptions, keen scrutiny of the culture's social, political, physical, and aesthetic influences on food patterns and styles plays a crucial role in clearly defining the cuisine. The English gastronomic heritage and the Indians' patterns of food procurement and preparation also affected Virginia's seventeenth-century cuisine; descriptions of those influences follow discussion of the colony's general historical context.

SEVENTEENTH-CENTURY VIRGINIA

Although Virginia's population and culture in the seventeenth century were emphatically English, historians today generally disagree with the old view of the colony as a transplanted England. Promoting the older view, Philip Alexander Bruce writes in 1907, "The community, from a social point of view, was as if some shire of England, with its whole population, had been moved bodily over sea." Then he adds, "In every important feature, the society of Virginia in the seventeenth century was the same as that far more celebrated

society which constitutes the most romantic side of the Colony's history in the eighteenth. . . ." ¹

Even the British historian George Macaulay Trevelyan disagrees sharply with that "transplanted England" idea: "after the first few years, the social history of America ceased for ever to be a part of the social history of England. The new society began to work out its own characteristics, under pioneer conditions of life very different from those that prevailed in the 'garden of England' in the days of Shakespeare and Milton." ² Oscar Handlin similarly warns that we must see the seventeenth century in its own terms and in relation to its past, *not* in relation to its future, writing that "the institutional life of the colonies can only be understood against a background that reaches back to the medieval past," and that to see in seventeenth-century institutions "the forerunners or prototypes of what would emerge in the eighteenth or nineteenth century is grievously to misinterpret them." ³

¹ *Social Life of Virginia in the Seventeenth Century* (Richmond: privately published, 1907), pp. 104, 157.

² *English Social History*, rev. ed. (London: Longman, 1978), p. 188.

³ "The Significance of the Seventeenth Century," in *Seventeenth-Century America*, ed. James Morton Smith (1959; rpt. New York: W. W. Norton, 1972), p. 3.

The People: A Social Context

The typical Virginian of the seventeenth century was English, a young white male of the middling or yeoman classes, a protestant of indifferent education. With a scarcity of women and little generational continuity, Virginia lacked the family-based society and social stability characteristic of New England. Separated from England by an ocean, settlers were also isolated from each other by the scattered nature of tobacco farming and by the lack of towns, communication, and transportation. Indeed, seventeenth-century Virginia had a rough, unstable frontier society more similar to the nineteenth-century American West than to stereotypical and inaccurate notions of a gracious, elegant Colonial Virginia.

The first Englishmen to come to Virginia were adventurers, not settlers. Seeking riches like those the Spanish found in South America, the Elizabethans sought through colonization such impractical dreams as an easy passage to the Far East and commercial exploitation of natural resources. Through the London Company years (1607-1624), Virginia was primarily a floundering military outpost centered at Jamestown.

Records fail to show that any of the first colonists, many of them gentlemen, left descendants for a second generation. Population growth came mainly from the influx of servant immigrants; not until the end of the century did Virginia begin to maintain its population through natural reproduction. In April 1618 Virginia had a population

of 400 persons; by 1625 the population had grown to 784, with three fourths of the population male and almost half of the females fourteen years old or younger.⁴ By mid-century the population had grown to 15,000, and then to an estimated 60,000 in 1700. Craven suggests that the population at the end of the century was no greater than the number of people who had migrated there during its course.⁵ Only at the end of the century were blacks significant either to the population or to the labor force: at mid-century the colony had 300 blacks, ten times that number by 1681, and 12,000—or twenty percent of the total population—in 1700.

If the blacks were a small part of the population at mid-century, the Indians were even less significant then. Before 1669, the native Americans had been pushed beyond the colony's western frontier, leaving the coastal settlers both safe from attack and cut off from the Indians' cultural influence.⁶

Although all but the highest and lowest classes of England were represented in colonial society, most Virginians were of the middling classes and most came as servants. Comprising as much as eighty-five percent of the population, Virginia's servant immigrants came from all over England and represented in part a restless, mobile population of

⁴ Irene W. D. Hecht, "The Virginia Muster of 1624/5 As a Source for Demographic History," *William and Mary Quarterly*, 3d Ser., 30 (Oct. 1973), 65-92. Wesley Frank Craven provides a comprehensive demographic study in *White, Red, and Black* (New York: W. W. Norton, 1977).

⁵ Craven, *White*, p. 26.

⁶ Craven, *White*, p. 61.

workers unable to find employment. Poor harvests and crop failures sent workers to the cities (London, Bristol, Liverpool) in search of jobs. Finding no employment there, the workers then took advantage of the system of indentureship to seek economic opportunity in the colony. Persons accustomed to the idea of apprenticeship found indentureship attractive and practical, offering passage to Virginia in exchange for seven years' work, and promising land and commercial independence after the period of service. Some immigrant servants were younger sons of the gentry, and many servants later prospered into prominent landowners and officials in the colony's government, but most historians now accept that the servants came mainly from the middling working classes, and that most were yeomen, or farmers and skilled workers from agricultural backgrounds.⁷

Both men and women servants typically emigrated between the ages of 15 and 24, with 20 or 21 the most common age. Single non-householders unlikely to own property and having little stake in society, these young people could not marry while servants. Men were in greater demand as servants because their labor was more urgently needed; regardless of their training, men were usually put to work in the tobacco fields. In the 1630s the ratio of male to female

⁷ See especially James Horn, "Servant Emigration to the Chesapeake in the Seventeenth Century," in *The Chesapeake in the Seventeenth Century*, ed. Thad W. Tate and David L. Ammerman (New York: W. W. Norton, 1979), pp. 51-95; and Mildred Campbell, "Social Origins of Some Early Americans," in *Seventeenth-Century America*, pp. 63-89. An earlier but useful study is Herbert Moller, "Sex Composition and Correlated Culture Patterns of Colonial America," *William and Mary Quarterly*, 3d Ser., 2 (April 1945), 113-53.

immigrants was six to one; at the end of the century the ratio declined to about two and a half to one.

The number of servants in Virginia remained fairly constant, but the emergence of servants from service into free status meant the number of freedmen increased continually and that a solid yeomanry developed in the colony. Because of the preponderance of servants among the emigrants, families were likely to be represented only among those who paid their own way. Freemen or men who had completed terms of indentureship sometimes secured wives by paying a woman's passage or buying the balance of her indentureship.

We know little about the women who came as servants. Classified as "singlewoman" or "spinster" in passage records, rather than by occupation, a greater proportion of women than of men perhaps represented the laborers, or lower classes. Campbell suggests that, within the social code of country people, yeomen and tradesmen would be more reluctant than laborers to see their daughters embark on a journey to the colony. Women of the laborer classes accepted work in the fields; women of the yeoman and trade classes did not. A single woman who chose to emigrate perhaps had more urgent needs for survival than did a single man, although in the colony a woman's opportunities for an advantageous marriage were clearly superior to her opportunities at home.

Seventeenth-century Virginians were not then aristocrats, but neither were they criminals or disreputable outcasts from society.

Most criminals deported or banished to the colonies were political prisoners or political refugees, and therefore from the higher, more educated classes. The average Virginian, on the other hand, had little opportunity to gain education, possessing whatever education he had before he emigrated, and with only practical, not academic, training likely to be acquired after arrival. Throughout the century the few wealthy planters hired tutors and sent sons (and sometimes daughters) to England to be educated, but the yeomanry, the great bulk of the population, had even less opportunity than in England to obtain education; local schools were rare until late in the century. According to Wertenbaker's calculations, during the second half of the century over half of the men could sign their names in full, but about three fourths of the women made marks rather than signed their names on deeds and depositions in fourteen counties.⁸

Books were a luxury in Virginia, and Bibles, books of sermons, and religious tracts figure prominently in the inventories of wealthy planters' libraries. On the infrequent occasions when one or two books appear in the probate inventories of less affluent persons, a Bible is most frequently mentioned. Although Virginia's settlers brought with them loyalty to the Church of England, religion never had in Virginia the importance it had in New England. During the London Company years, enforced piety and church attendance resulted

⁸ Thomas Jefferson Wertenbaker, *The First Americans 1607-1690*, Vol. II of *A History of American Life*, ed. Arthur M. Schlesinger and Dixon Ryan Fox (New York: Macmillan, 1938), p. 254.

from strict laws, not from inclination. The parish served as the local unit of both state and church, and although basic church doctrines were the same in England and in Virginia, their organization and government were different. The rigid English doctrine became more democratic in the colony; distance and isolation reduced church attendance and kept the clergy from conforming to the liturgy.⁹

The dispersion and isolation that eroded ecclesiastical influence also fostered social instability, even an "abnormal" social order. Men and women who paid their own passage to the colony were usually of the same social classes as the servants. The small aristocracy of planters who rose in prominence during the century gained wealth and power through mercantile accomplishments rather than through genteel birth, sometimes beginning their rise as servants. Shrewd, sharp, and even stingy, the evolving oligarchy attained political as well as economic power. Just as in England, one or two families dominated the affairs of each county, and public office—so long as it had a salary and regardless of its importance—was sought even by the wealthy. Prominent Englishmen held Virginia's colonial life in low esteem, believing the "better" people could succeed at home or in the more established West Indian sugar colony; this low opinion of Virginia life led its more successful settlers to view public life not as prestigious or honorable but as a way to protect personal interests.¹⁰

⁹ See Wertenbaker, *First Americans*, pp. 116-18, 124.

¹⁰ See Carole Shammas, "English-Born and Creole Elites in Turn-of-the-Century Virginia," in *The Chesapeake in the Seventeenth Century*, pp. 274-96.

The early planters were not "chivalrous," not gallant or honorable. As Wertenbaker tartly observes, "The mortal enemy of chivalry is commerce."¹¹

During most of the century small independent farmers flourished and attained economic strength.¹² Labor was scarce, however, and households small. The shortage of women through mid-century prompted many men without wives to set up all-male households. The practice in which households rather than families served as a focus for daily life and for relationships reflected similar conditions in rural England at the time, when demands for joint labor for mutual survival resulted in a kind of enforced communal work and living.¹³

Scarcity gave women more power and influence than in England. Very few women remained unmarried, and with the high mortality rate some had as many as five or six husbands in a kind of serial polyandry; although widows almost always remarried, widowers rarely had an opportunity to do so. Few children reached adulthood without losing at least one parent; over a third lost both. With assortments of ages and relationships in households—half-brothers, stepsisters,

¹¹ Thomas J. Wertenbaker, *Patrician and Plebian in Virginia* (Charlottesville: privately published, 1910), p. 67. For a more recent comprehensive discussion of the interrelationships in Virginia of commerce, politics, and social structure, see Bernard Bailyn, "Politics and Social Structure in Virginia," in *Seventeenth-Century America*, pp. 90-115.

¹² See Lois Green Carr and Russell R. Menard, "Immigration and Opportunity: The Freedman in Early Colonial Maryland," in *The Chesapeake in the Seventeenth Century*, pp. 206-42.

¹³ For a discussion of pre-industrial English society, see Peter Laslett, *The World we have lost*, 2nd ed. (London: Methuen, 1971).

wards, orphans, servants, and even some "regular" parents and children—households were mixed and disorderly affairs, with little base for a centered emotional focus or even a primary sense of family.¹⁴ Since high mortality affected both adults and children, few marriages produced more than two surviving children. Yet family ties were strong in spite of disorder in domestic life, perhaps because of the demands for communal cooperation in order to prosper and survive. Women had heavy responsibilities. On the large plantations they helped manage the complex operation and took control in the absence, or after the death, of their husbands. On the small plantations they shared in physical labor in the fields, for small planters often had only one servant, or else worked their plantations alone.

Just as family or "household" life had a disorderly character, amusements and entertainment tended to be immoderate on the infrequent occasions when freedom from labor and access to company made conviviality possible. Court days, or meetings of the court to which people traveled from sometimes considerable distances, provided opportunity for small planters to amuse themselves free of the isolation of their farms, while the day of revelry served servants and slaves as a prime time for running away. House parties (on the larger

¹⁴ Darret B. and Anita H. Rutman, "'Now-Wives and Sons-in-Law': Parental Death in a Seventeenth-Century Virginia County," in *The Chesapeake in the Seventeenth-Century*, pp. 153-82. See also Lorna S. Walsh, "'Till Death Us Do Part': Marriage and Family in Seventeenth-Century Maryland," in *The Chesapeake in the Seventeenth-Century*, pp. 126-52.

plantations), marriages, and funerals also relieved the isolation and were considered occasions for indulgence in much food and strong drink. Gambling of all sorts was popular: horse races, cards, dice, nine-pins. Religious holidays were more somber than festive, with days of thanksgiving decreed as days of "fast and humiliation" and Christmas playing only a small and quiet part in the life of the colony.¹⁵

Both the social and economic orders of Virginia shifted at the end of the century, with changes brought about by the rise of slavery. The influx and availability of slaves ended the importation of servants; slaves constituted permanent labor, while servants demanded continuous replacement as they completed their terms of indenture. Large planters grew larger, while small planters grew smaller and sometimes were even forced to leave the colony. More slaves and more land for tobacco meant more wealth, more power, and higher social standing. The sturdy "Virginia yeomanry" who had managed earlier to compete and succeed with dignity, both economically and socially, declined. Virginia moved from a colony with a strong middle class to one with two extremes: rich and poor.¹⁶

¹⁵ See Mary Newton Stanard, *Colonial Virginia: Its People and Customs* (1917; rpt. Detroit: Singing Tree Press, 1970) p. 331; and Louis B. Wright, *The Cultural Life of the American Colonies 1607-1763* (1957; rpt. New York: Harper and Row, 1962), p. 188.

¹⁶ For an interesting, although dated, discussion of the evolution of social classes in Virginia, see, in addition to his *Patrician and Plebian*, Thomas J. Wertenbaker's *The Planters of Colonial Virginia* (Princeton: Princeton Univ. Press, 1922).

The Political Context

When James I agreed to the founding of the Virginia Company and the colonization of America, he surely never intended to foster the growth of liberal institutions in Virginia. Yet distance, isolation, and private ownership of land did engender independence and freedom in the New World. Although control of the letter of the law always lay in England, power in practice lay in the colony itself—months passed before the English government knew of critical events in the colony, or before the English government could respond to actions already taken in the colony.

Government under the Virginia Company (1607-1624) was a harsh species of military law. The Company charters did, however, request that settlements be fixed in "wholesome" locations with sun and fresh water, possess a common grange and grain storehouse, and provide its men with regimented meals.¹⁷ During the grim initial period when food was not produced in the colony, provisions were rationed and severe punishments were meted out for stealing food. To protect livestock until it could increase through breeding into a substantial and self-perpetuating source of food, butchering animals for food was restricted or forbidden. When the first settlers learned that growing tobacco could bring money, they planted even the streets of Jamestown

¹⁷ Virginia Council, "Instruccions Orders and Constitucions . . . to Sir Thomas Gates Knight Governor of Virginia" (1609), in *The Three Charters of the Virginia Company of London with Seven Related Documents: 1606-1621* (Williamsburg: Virginia 350th Anniversary Celebration Corporation, 1957), pp. 59, 64-65.

in tobacco and had to be forced by law to plant certain portions of their land in corn.¹⁸ New settlers were to be provided with food for a year (the length of time necessary to begin harvesting enough food for survival) and the early years of the colony saw much emphasis on a "commonwealth," or common storehouse to which all were to contribute. John Rolfe gives this account of responsibility for both individual and common stores:

[The farmers are bound to] mayntayne themselves and famylies with food and rayment. And every *Farmor* to paie yerely into the Magazin for himself and every manservaunt two barrelles and a half apeece of their best Indian wheate, which amounteth to twelve bushelles and a half of Englishe measure.¹⁹

Soon after the end of the London Company period, self-interest and the opportunity to acquire land and work it profitably prompted settlers to develop agriculture toward self-sufficiency. The "common store" had a very short life. Under the General Assembly laws imposed penalties much less severe than those of the earlier martial law, and the tendency toward representation and self-government emphasized a local rather than a provincial control, with a wide distribution of authority. Tax collection figured prominently as an activity of government: land was taxed through "quitrents," with the proceeds paid to the king in tobacco; and "tithables," or males over

¹⁸ Virginia Company, "Instructions to the Governor and Council of State in Virginia" (1621), in *Three Charters*, p. 115; Ralph Hamor, *A True Discourse of the Present State of Virginia* (London, 1615; rpt. Richmond: Virginia State Library, 1957), pp. 17, 19-20.

¹⁹ John Rolfe, *A True Relation of the State of Virginia Lefte by Sir Thomas Knight in May Last 1616* (Charlottesville: Univ. Press of Virginia, 1971), p. 8.

sixteen, were subject to a "head tax," or public levy which was the progenitor of the poll tax.

Penalties for breaking laws in Virginia were generally milder versions of English punishments. Crime was less common than in England, perhaps because the ready availability of employment and food meant less incentive to commit crimes.²⁰ But, as Susie M. Ames points out, free speech was not permitted in the colony, and loyalty to the king was important. The Biblical Decalogue was "publicly emblazoned and literally applied," with the most frequently violated commandments mentioned most frequently in the laws: offenses related to oaths, Sabbath observances, slander, and immorality.²¹ Punishments sometimes ingeniously "fit the crime"—in 1648 when Robert Warder was sentenced for drunkenness in Northampton County, he was compelled to stand at the church door with a great drinking pot tied about his neck.²² Fines, confinement in the pillory and stocks, whipping, and ducking (of women) served as the more common colonial punishments. Ames writes that those punishments

reflected the harshness, the grasping quality of pioneer life. That which life gave most abundantly to the individual, colonial punishment sought to take from him. From the man of wealth it took some form of money; from the servant and slave, bodily strength; and from the woman, dignity.²³

²⁰ Wertebaker, *First Americans*, pp. 210-13.

²¹ Susie M. Ames, *Studies of the Virginia Eastern Shore in the Seventeenth Century* (Richmond: Dietz Press, 1940), pp. 12, 179.

²² Stanard, *Colonial Virginia*, p. 330.

²³ Ames, *Studies*, p. 197.

Of the "common" crimes or judicial problems, drunkenness caused so much concern that attempts to prevent or alleviate it included extra duties on imported rum and laws suppressing ordinaries and taverns.²⁴ The greatest impetus for tariffs on imports, however, was England's determination to prevent trade with anyone except herself. Virginians bought clothing, furniture, tools, and even building supplies from England. Although colonial leaders sought diversification of agricultural production, tobacco almost totally dominated the economy. Their farms scattered in isolation along the tidal rivers, planters traded not with each other but with foreign merchants; English ships docked at planters' private wharves to trade merchandise for tobacco. With no towns and no trade within the colony, the large planter was bound more to his London agent than to his neighbors. And he became the middleman for smaller planters; smaller planters both traded their tobacco and bought goods through the large planters, and what was first a "storehouse" for the planter's own supplies developed into a "store" for the surrounding area. Then as imported goods became increasingly expensive, plantation manufacturing began to develop. Coopering was one of the earliest trades practiced, joined by carpentry, blacksmithing, and some tanning and weaving. The colonists were most self-sufficient in production of their own food. Except for sugar, molasses, salt,

²⁴ Wertenbaker, *First Americans*, pp. 200, 301. Also to discourage indulgence, legislation decreed that no debts made in buying wines could be sued for in court; see Bruce, *Social Life*, p. 179.

distilled spirits, spices, and wine, food was generally grown and processed at home; and probably only the wealthier settlers bought sugar or spices or wine.²⁵ Plantation manufacture in the seventeenth century bears little resemblance, however, to the large-scale operations of the next century. As Ames emphasizes the distinction,

the clearly defined and relatively stable plantation system of the eighteenth century does not have its counterpart in the seventeenth century, . . . the term plantation may prove misleading, if by it one visualizes a large area under cultivation. A comparatively small field, accessible to the water and surrounded by many acres or even miles of woodland, greeted the seventeenth century traveler.²⁶

Because tobacco depleted the land, planters continually required new land for its culture, and the headright policy eased that acquisition. Each settler was allotted by law fifty acres of land for each member of his family. Also, fifty acres were granted to a person for each emigrant whose passage he paid, or for each slave he purchased. Sometime before 1692, headrights began to be sold outright, so very large plantations could be amassed easily.²⁷ Although land was cheap and easy to get, small or beginning planters could also lease land; sometimes leases even required that tenants plant orchards with specified numbers of trees of various varieties.²⁸ Large planters often owned multiple tracts of land separated from each

²⁵ For an extensive study which encompasses trade and agriculture, see Philip Alexander Bruce, *Economic History of Virginia in the Seventeenth Century*, 2 vol. (1895; rpt. New York: Peter Smith, 1935).

²⁶ Ames, *Studies*, pp. 31-32.

²⁷ Craven, *White*, pp. 16-17.

²⁸ Ames, *Studies*, p. 41.

other and scattered through the country. They usually lived on the "home" plantation and either leased other tracts or hired overseers to run them. Near the end of the century large plantations were broken up by sales and wills so that many included 500 acres or less; by 1700 perhaps only one in fifteen planters owned over a thousand acres.²⁹

The Physical Context

Tidewater Virginia represented to its first visitors a bountiful Garden of Eden, a benevolent virgin wilderness replete with natural riches and haloed with promises of easy fortune. Yet the first English settlers were almost defeated by the seemingly benign paradise, inept at eking from it even the meanest subsistence in food and lodging, failing to preserve health, impotent against the attacks of disgruntled native "savages." Fanciful, misguided, and ill-equipped expectations met an unyielding land hostile to those lacking the skills and knowledge with which to tame it.

The Chesapeake Bay provided first explorers and then settlers with a seemingly endless coastline of convoluted rivers, inlets, creeks, and marshes, protected from the Atlantic Ocean without and giving access to the forested mysteries within. The bay and tidal rivers teemed with fish and shellfish; early accounts tell of fish almost spilling into boats and huge banks of oysters obstructing ships' passage. The skies, woods, and waters abounded with edible birds.

²⁹ Ulrich Bonnell Phillips, *Life and Labor in the Old South* (New York: Grosset and Dunlap, 1929), p. 34.

Game proliferated, and countless varieties and limitless quantities of wild fruits, nuts, and roots all but choked the forests.

Early Virginians found that both plants and animals thrived in the moderate climate and on the fertile land. With a longer, warmer growing season than in England, plants grew bigger and grew more quickly. Foraging in the natural pasturage, animals also increased in size and number more than in England. Yet the London Company had only moderate interest in agricultural development beyond provision for the colony's self-sufficiency. They saw the forests as a source of lumber, clapboards, and potash; the bay as a source of salt and caviar; cultivation of the land as desirable for grapes and wine production, silk culture, and the growing of citrus crops and olives. None of those ambitious objectives found fruition.

One might wonder today, when visiting Tidewater's marshy shores or driving through the sandy woods on Jamestown Island, if seventeenth-century Virginians experienced the same environment without the trappings of civilization and with more natural bounty. Probably not. The greatest difference was perhaps the forests, dominated then by towering hard woods where today scruffy pines betray the depleted soil. Hot and humid summers presaged current weather conditions, but winters were colder and more severe than today—early accounts tell of rivers frozen from bank to bank.³⁰

³⁰ Excerpt from letter [from Francis Perkins?], 1608, in *The Genesis of the United States*, ed. Alexander Brown, Vol. I (1890; rpt. New York: Russell and Russell, 1964), p. 175.

Environmental hostility, even unsuitability, is reflected in the conditions described by William Strachey:

. . . I may not excuse this our fort, or Jamestown, as yet seated in somewhat an unwholesome and sickly air, by reason it is in a marish [marshy] ground, low, flat to the river, and hath no fresh-water springs serving the town but what we drew from a well six or seven fathom deep, fed by the brackish river oozing into it; from whence I verily believe the chief causes have proceeded of many diseases and sicknesses which have happened to our people, who are indeed strangely afflicted with fluxes and agues, and every particular infirmity too: all which, if it had been our fortunes to have seated upon some hill, accommodated with fresh springs and clear air, as do the natives of the country, we might have, I believe, well escaped.³¹

Many writers attribute the starving, sickness, and discord of the early colony to character flaws in the settlers: laziness, ineptness, greed, and insubordination. Recent scholarship, however, more typically points out the weakened state of newcomers forced to endure the prolonged hardships of long sea voyages with poor and inadequate diet and unsanitary, infested conditions. In an important study of "Environment, Disease, and Mortality in Early Virginia," Carville V. Earle rejects the long-held belief that new settlers required "seasoning" or adaptation to the new environment, pointing out that no one could develop immunity to typhoid, dysentery, and salt poisoning—the three main causes of death in Virginia.³² Earle even

³¹ William Strachey, "A True Reportory of the Wreck and Redemption of Sir Thomas Gates, Knight," in *A Voyage to Virginia in 1609: Two Narratives, Strachey's "True Reportory," Jourdain's "Discovery of the Bermudas,"* ed. Louis B. Wright (Charlottesville: Univ. Press of Virginia, 1964), pp. 82-83.

³² In *The Chesapeake in the Seventeenth Century*, pp. 96-125.

persuasively suggests that "the idle, lazy, and factious behavior of early Virginians was, in part, the result of a steady summer diet of salty water."³³ Early leaders (except for the canny and resourceful John Smith) tried to force a concentration of settlers at Jamestown, and thus essentially enforced a high mortality, with the brackish water and close confinement accelerating the spread of disease. The river water was safe in the spring, when rains and river discharge were heavy; but during the hotter, drier summer, evaporation and stagnation increased the salt concentration of the water, and the settlers were subject to salt poisoning.

Earle points out that John Smith, a more sensitive ethnographer than his fellows, had understood in some measure the survival value of the Indians' seminomadic life. In the spring they lived along the river, eating seafood while they planted their crops; then during the summer they broke up into smaller groups and lived on higher ground with fresh water springs, still maintaining access to the seafood supply. The Indians reassembled into larger groups in the fall, harvested their crops (corn, squash, and beans), and gorged on the plenty in preparation for the leaner winter when they broke up into smaller groups again for hunting in the piedmont region. When the colonists began to settle farther up the rivers—where water had less salt—and began to move inland, the mortality rate decreased. Earle suggests that changes in dietary habits may have also contributed to

³³ Earle, "Environment," p. 103.

increased survival, that the settlers may have increased consumption of cider, beer, and wine instead of water, and eaten fewer microorganism-ridden shellfish during the summer.

The Virginia colony had other difficulties adjusting to its environment and living in harmony with it. Game was available all year, but hunting was dangerous during periods of Indian hostility. Livestock—chiefly cattle and hogs, with some sheep—suffered from indifferent care; although hogs thrived on the food they foraged in the forest, cattle grew weak and scrawny during severe winters. Drying and salting were the only methods of preserving perishable foods, and salt was difficult to obtain (recurrent attempts to produce salt in the colony met only fitful and limited success). Concentrating almost all agricultural production on the land-greedy tobacco farming, settlers were reluctant to clear land for less lucrative crops. Broadcast seeding (necessary for wheat, rye, barley, and oats) required plowed fields; corn, which did not demand plowed fields but could be simply stuffed into the soil Indian-fashion, served as the staple food crop, easy to dry and store. Some wheat was grown, along with a good deal of beans and peas. Vegetable gardens were common, and planters took great pride and lavished some care on large orchards; accounts suggest that the early settlers enjoyed an even greater variety of fruits than do the people of today.

Technology contributed little to food production. By mid-century grain mills began to appear, but they were scattered and not widely

available; many items in estate inventories relate to the home milling of grain. Tools such as iron plows, hoes, and sickles had to be imported; and although oxen and other cattle served as draft animals, horses were rare and almost useless except for transporting people—many were turned loose to run wild. Even in 1670 a man who possessed a horse was considered a wealthy man.³⁴

Except for the serious production of tobacco and corn, and home gardens for survival, agriculture in seventeenth-century Virginia had a peculiarly dilettantish quality. The early enthusiasm for growing exotic commodities (olives, lemons, sugar) imitated the Spanish approach in the Caribbean; and those efforts, along with the mostly unsuccessful attempts at wine production and sericulture, echoed the impractical dreams of Elizabethan adventurers who wanted to free England from dependence on foreign sources for those products.

Botany found enthusiasts in two clergymen: the Reverend John Banister cataloged Virginia's plants, and the Reverend John Clayton published a description of Virginia's natural history.³⁵ Travelers customarily brought seeds and plants home to try in gardens or give

³⁴ Wesley Frank Craven, *The Southern Colonies in the Seventeenth Century, 1607-1689*, in Vol. I of *A History of the South*, ed. Wendell Holmes Stephenson and E. Merton Coulter (N. p.: Louisiana State Univ. Press, 1970), p. 370. For discussions of the development of agriculture, see Bruce, *Economic History*; and Lewis Cecil Gray, *History of Agriculture in the Southern United States to 1860*, Vol. I (Washington: Carnegie Institution of Washington, 1933).

³⁵ See Joseph and Nesta Ewan, *John Banister and His Natural History of Virginia 1678-1692* (Urbana: Univ. of Illinois Press, 1970); and *The Reverend John Clayton, A Parson with a Scientific Mind*, ed. Edmund Berkeley and Dorothy Smith Berkeley (Charlottesville: Univ. Press of Virginia, 1965).

to friends, and adventurous planters exchanged seeds and plants with neighbors at home and with friends in England. American herbs, and the Indians' mysterious use of them, also aroused great curiosity and interest among the scientifically inclined settlers. Dr. Lawrence Bohun, who came to Jamestown in 1610, experimented with the medical usefulness of native plants and endorsed sassafras, whose roots were considered a rich commodity because of their reputed ability to cure syphilis and other diseases.

Books of "physic" appear prominently in the inventories of planters' libraries, and the age—however fraught with ignorance and superstition—had some understanding of the importance of hygiene. Each household had to care for the health of its members, and as the large plantations evolved into substantial communities their mistresses became responsible for ministering to ills and injuries. Removal from even the primitive health care possible in the seventeenth century was but one of the deprivations of isolation and distance.

Roads were mainly old Indian trails and paths too rough for wagons or carriages. Travel over land was almost always on horseback; water was the important highway, boats the major means of transportation. Today we think of rivers as separators, obstacles to be "got round" or crossed with bridges. Water, however, linked seventeenth-century settlements and farms—the river was the road the plantation faced, and the dock or wharf was its driveway. Both visiting and commerce were accomplished through water travel.

Virginia had few communication or transportation links with the other American colonies. Although an intercolonial postal system slowly developed, Virginia was so tied to England that it had neither need nor desire for such a system, and had essentially no postal contact with the northern colonies during the century. Mail and trade communication between England and Virginia was both slow and seasonal. Tobacco ships sailed in convoys as protection against pirates and privateers, usually leaving Virginia for England in spring or early summer and returning in the autumn. Anyone who failed to get a letter dispatched with the spring fleet might have to wait a year for the next departure of mail for England. A westward voyage across the Atlantic of six to eight weeks was considered good; eastward trips took even longer because of headwinds, with ships sometimes delayed for weeks or even months by unfavorable winds or calm. Some wealthy Virginians made recurrent trips to England, and some always thought of themselves as Englishmen only temporarily residing in Virginia. The settlers of but average resources, however, came to Virginia and stayed, communicating with England neither in person nor through written correspondence.

In their buildings Virginians employed Anglo-Saxon styles and structures of a thousand years earlier; early settlers built not log cabins but types of traditional medieval architecture.³⁶ First they

³⁶ See Henry Chandlee Forman, *The Architecture of the Old South: The Medieval Style 1585-1850* (Cambridge: Harvard Univ. Press, 1948).

constructed the palisade, or little fort, with stockaded walls. The first houses were puncheon structures of upright timbers set into the earth and spaces filled with wattle-and-daub—twigs woven into a wall and daubed with a plaster of lime, loam, and straw. Facsimiles of these small and crude thatched-roof dwellings may be examined today at Jamestown in the conjectural reconstruction of the first fort. Some of the first houses had chimneys; others did not. In England fires were originally built in the center of the room, with the smoke retained in the room or escaping as best it could through a roof opening. Later, houses had hooded fireplaces with wattle-and-daub chimneys. The "cruck house," or simplest English dwelling, consisted of a single bay, or room, sixteen feet square. Builders began to use timber framing, and then part brick and part frame construction. Wooden chimneys succeeded the rougher wattle-and-daub flues, sometimes with brick or stone backing in the hood and on the ground floor. Figure 3 shows what may have been a typical "middling" dwelling in Virginia: the Utopia Cottage, 1660-1700, excavated at Kingsmill.

The plainest early country houses had one multi-purpose room comparable to the medieval "hall"; often it had a loft for sleeping and an attached outdoor lean-to structure for rough storage. As the country house developed, a parlor was added to the hall in the two-room "hall-and-parlor" structure. In the next stage the hall was partitioned to make a central passageway, creating the "central-

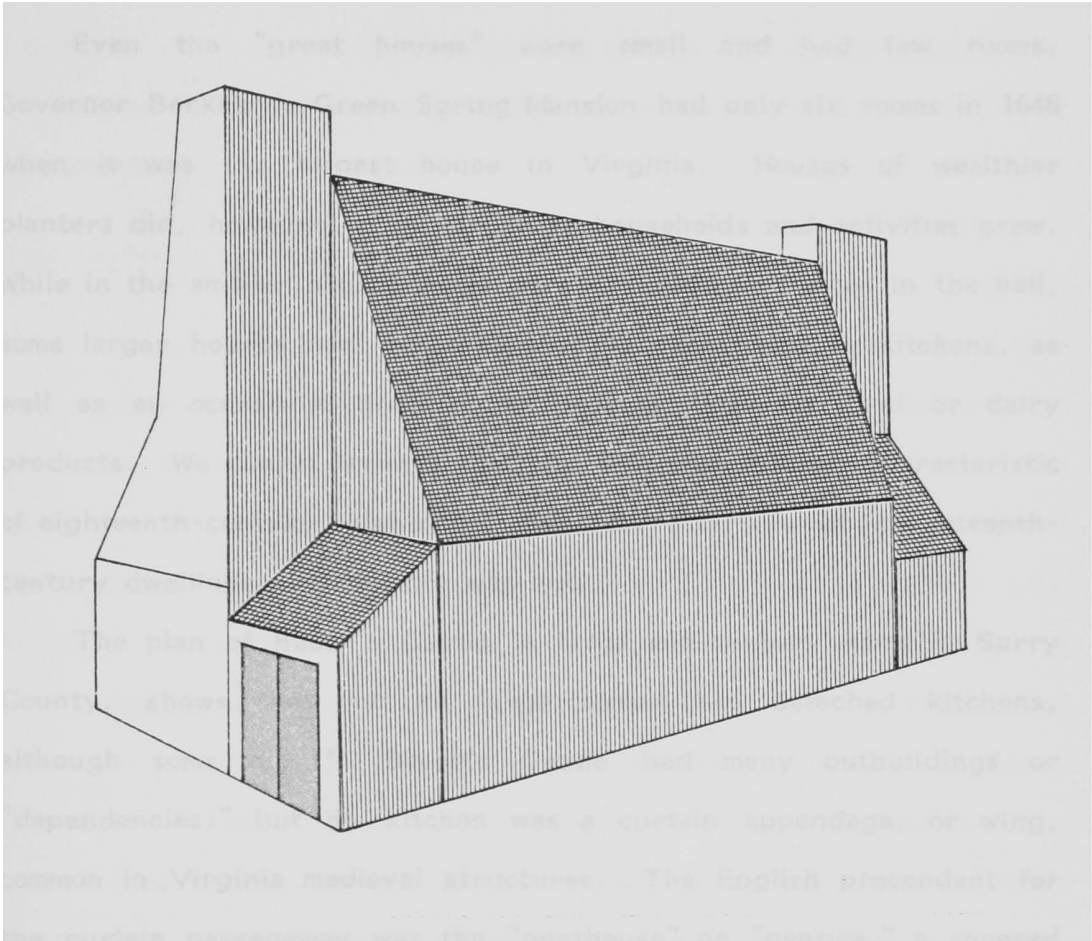

Figure 3. Form reconstruction of Utopia Cottage, 1660-1700, with timber and clay hooded chimneys and a bulkhead entrance. Drawn from William Kelso, "An Interim Report, Historical Archaeology at Kingsmill, The 1974 Season," March 1976 (manuscript at Virginia Research Center for Archaeology, Williamsburg), Figure 4.

passage" type. Then in the fourth stage an entrance porch was added to the front and a stair tower to the back, to constitute the "cross-house."³⁷

Even the "great houses" were small and had few rooms. Governor Berkeley's Green Spring Mansion had only six rooms in 1646 when it was the largest house in Virginia. Houses of wealthier planters did, however, grow larger as households and activities grew. While in the smaller houses meals were prepared and eaten in the hall, some larger houses had rooms specifically designated as kitchens, as well as an occasional buttry, or storage room for food or dairy products. We cannot assume that the detached kitchen characteristic of eighteenth-century plantations was characteristic of seventeenth-century dwellings; it probably was not.

The plan of Bacon's Castle, a large mid-century home in Surry County, shows that not all large homes had detached kitchens, although some did.³⁸ Bacon's Castle had many outbuildings or "dependencies," but its kitchen was a curtain appendage, or wing, common in Virginia medieval structures. The English precedent for the curtain passageway was the "penthouse" or "pentice," a covered passage between hall and kitchen. One might conjecture that the hot summers and the later availability of slaves for kitchen labor contributed to the later detachment and removal of the kitchen from

³⁷ For drawings of plans for each type, see Foreman, *Architecture*, figures 37, 39, 41, 43.

³⁸ Foreman, *Architecture*, figures 61, 96, 101.

the main house. Many historians suggest a social significance in the removal of the kitchen to keep slaves distant. Since servants were scarce during most of the seventeenth century, however, and slaves numerous only at its close, cooking within the house—whether in kitchen or hall—was probably more convenient and practical for most households.

The Aesthetic Context

The last twenty-five years have seen dramatic changes in the way seventeenth-century daily life is portrayed. We can see pronounced contrasts if we compare the conjectural paintings of Jamestown life made in the 1950s with the recent conjectural representations of life at Wolstenholme Towne, the early seventeenth-century settlement only recently excavated by archaeologists from Colonial Williamsburg.³⁹ The Jamestown drawings suggest a tidy prettiness—pointed Elizabethan beards, starched ruffs, neat picket fences, mullioned windows. Wolstenholme Towne, on the other hand, appears unkempt and scruffy, with frayed thatch, workers in coarse clothing, mud puddles, tethered goats near rough shuttered windows—and this peasant-like disorder

³⁹ Conjectural paintings of Jamestown are in *A Pictorial Album of Jamestown, "Birthplace of America,"* paintings by Sidney E. King, text by J. Paul Hudson (N. p.: n. p., 1963); other renderings appear in John L. Cotter, *Archeological Excavations at Jamestown, Colonial National Historical Park and Jamestown National Historic Site, Virginia*, Archeological Research Series No. 4 (Washington: National Park Service, U. S. Department of the Interior, 1958). Conjectural paintings of Wolstenholme Towne appear in Ivor Noel Hume, "First Look at a Lost Virginia Settlement," *National Geographic*, 155 (June 1979), 734-67.

seems a more convincing and believable representation of the typical seventeenth-century experience in Virginia.

Most people had limited numbers and varieties of possessions; often the distinction in estate inventories between well-to-do and poor is more in quality than in quantity: feathers instead of cattails for beds, pewter instead of wood for plates. Wealthier people sought English amenities by ordering furnishings and clothing from London agents, but the middling people had known little comfort in England and probably accepted rough surroundings without question or resentment. Wertebaker offers another explanation:

In the first hundred years of the colony's existence there was a conspicuous lack of that elegance in the houses, the furniture, the vehicles, the table ware, etc., that was so much in evidence at the time of the Revolution. This was due in part to the newness of the country. It was impossible amid the forests of America, where artisans were few and unskillful, to imitate all the luxuries of England, and the planters were as yet too busily employed in reducing the resources of the country to their needs to think of more than the ordinary comforts.⁴⁰

Because of the labor shortage even artisans were put to work in the tobacco fields. Explaining that colonial crafts did not begin to flourish until the eighteenth century, Carl Bridenbaugh observes that no craft "had progressed beyond the household stage by 1700. . . . American arts and crafts entered the new century wholly devoid of organization beyond the basic family unit."⁴¹

⁴⁰ Wertebaker, *Patrician*, pp. 109-10.

⁴¹ *The Colonial Craftsman* (Chicago and London: Univ. of Chicago Press, 1961), p. 6.

Although the absence of towns or cities precluded commercial entertainment, music and dancing were popular home entertainments, and violins even appear in a few estate inventories. No books were printed in Virginia during the seventeenth century, and except for John White's late sixteenth-century watercolor paintings of Indians, no pictorial art is extant. Settlers brought with them portraits of their ancestors, or commissioned paintings by English artists. Sometimes portraits ordered from England were painted from written descriptions, with a courtly and aristocratic appearance deemed more important than a reasonable likeness.⁴²

A dearth of extant artifacts, pictorial records, and written descriptions, presents us with the same mysteries and questions about clothing and home furnishings that we face about the style of food. Inventories reveal that Virginians had beds with bolsters and valances, turkey carpets covering trestle tables, joint chairs and stools, cupboards and trunks, pewter, linens, falls and hanging sleeves—even an occasional wig. The appearance in inventories of beaver hats, red silk, and smoothing irons indicate a love of finery and the desire to maintain it, just as the excavated sherds of blue and white delftware, orange and yellow sgraffito ware, and Bellarmine bottles with whimsical bearded faces might indicate an affection for colorful and even imaginative crockery. We might conclude then that aesthetic refinement was sought in the degree to which it was part of

⁴² Wright, *Cultural Life*, p. 209.

a person's previous experience and to the extent to which it was within his means.

Summary

In a study of seventeenth-century Virginia's historical context, these factors emerge as potent influences on the cuisine:

- 1) English yeomen, servant immigrants from the middling classes, largely comprised the population.
- 2) Women were scarce, and family life lacked the stability and influence characteristic in New England.
- 3) Blacks played only a minor role in both the population and the labor force until late in the century.
- 4) The evolving social oligarchy was based on mercantile interests and political power.
- 5) Tobacco's dominance of the economy discouraged agricultural diversity and development.
- 6) The wilderness which generously provided game, seafood, and edible plants also presented the settlers with an untamed and even hostile physical environment.
- 7) Virginians lived in small, often crude dwellings and lacked technological resources.
- 8) Dispersed and isolated, without communication, transportation, or towns, settlers turned to home manufacturing for daily needs.

- 9) The labor shortage and rough living environment discouraged elegance, art, and comfort.

VIRGINIA'S ENGLISH GASTRONOMIC HERITAGE

Two distinct and dissimilar cuisines fed England during the seventeenth century: an elite cuisine derived from the medieval style of cooking in which foods were pureed to indistinguishability and lavishly enriched, sweetened, and spiced; and a yeoman cuisine in which humble foods were prepared in simple and straightforward fashion. That yeoman cuisine—based on pottage, bread, cheese, and ale—comprised seventeenth-century Virginia's gastronomic heritage.⁴³

Bad harvests and food shortages made the seventeenth century a harsh time for England's poor. Both meat and grains were expensive, and cottagers who could afford to keep only pigs and poultry found milk "dear" and hard to get. Drummond and Wilbraham write that most villagers and country people "seem to have lived on broth, prepared with beans and salted meat, bread, fish, cheese, a little bacon, and what they could trap or snare."⁴⁴ Wheat bread was for

⁴³ Jay Allan Anderson has provided in "'A Solid Sufficiency': An Ethnography of Yeoman Foodways in Stuart England" (Diss. Univ. of Pennsylvania 1971) an extensive study of the foodways heritage of the New England settlers. Also see J. C. Drummond and Anne Wilbraham, *The Englishman's Food*, rev. Dorothy Hollingsworth (London: Jonathan Cape, 1957); C. Anne Wilson, *Food and Drink in Britain* (London: Constable, 1973); and G. E. Fussell, *The English Rural Labourer* (London: Batchworth, 1949).

⁴⁴ Drummond and Wilbraham, *Englishman's Food*, p. 99.

the affluent; often peas or barley constituted the bread of those who could not afford even the common maslin (mixed-grain) bread of rye and wheat.

Yeoman families produced, processed, and prepared their food supply at home, the burden of labor and skill falling to the housewife who kept livestock, cared for the garden, made cheese, salted meat, and pressed cider. When income or barter allowed other foods, country people bought salt, sugar, fish, dried fruit, spices, and malt. Vegetables, fruits, and nuts were grown on the home-lot; except for acorns used in "brawn," a dish of pork and acorn mast, little use was made of wild or natural plants. Often families had to sell the premium foods they produced, keeping only those in less demand.

Pork was the most common meat, both because pigs required little care and because they served no purpose other than food. Cattle were bred for dairy and draft purposes; only a rare surplus or an old and useless animal could be sacrificed for table beef. Other livestock included goats, sheep, rabbits, chickens, geese, and ducks. Pork and beef were usually salted; sometimes meat was preserved only briefly in the summer by green-salting in brine. Since mutton did not preserve well, it was generally roasted fresh for festival meals.

Both ewes and goats sometimes served as a source of milk and cheese. Purchased seafood was usually salted or dried; fresh fish and shellfish were prized luxuries. Although poultry was kept more for eggs than meat, poultry which did reach the dinner table was fresh,

not salted or dried. The English ate a great variety of birds, especially prizing doves and pigeons—which the elite raised in dovecotes.

For most country people, "white meats"—milk, cheese, buttermilk, and whey—took the place of flesh meats in the diet. Only young children and old people drank milk, and usually only the wealthy used butter for cooking; most milk was converted into cheese. Housewives made four types of cheese: a fresh "green" cheese from whole milk, comparable to cottage cheese or cream cheese; a herb-flavored fresh cheese called *spermyse*; matured but not aged soft cheeses from semi-skimmed milk; and aged hard cheeses from skimmed milk. Although the rich, perishable fresh cheeses were most valued, the aged hard cheeses proved more practical as long-range provisions.

Sharing with cheese the role of protein source, legumes and grains appeared in spoonmeats—pottages, porridges, and gruels; especially common were pease porridge and baked beans. The yeoman had two kinds of vegetables: pot and sallet (salad). Pot vegetables included, in addition to the legumes for soups (pottages) and baked dishes, the cabbage, carrots, turnips, and parsnips of boiled dinners. Both hot and cold salads were seasoned with salt, olive oil, and vinegar; into them went lettuce, cabbage, spinach, beets, leeks, cress, radishes, cucumbers, marigolds, violets, and herbs such as parsley, sage, mint, rue, and rosemary. Long looked upon with suspicion except in soups and salads, vegetables were believed to

cause flatulence and melancholy, and rarely appeared as side dishes accompanying meat.⁴⁵

Home orchards produced apples, pears, plums, cherries, and peaches as well as chestnuts, walnuts, and filberts. Strawberries, raspberries, and blueberries were gathered in season. Since the English believed raw fruit unsafe and a cause of sudden fevers, fruit was generally cooked, often stewed until very soft. Fruit pies and tarts (especially apple) were popular, often sweetened with home-harvested honey. Other popular sweet dishes were custards and puddings—steamed mixtures of flour, fat, eggs, bread, fruit and spices. The most frequently purchased dried fruits included prunes, currants, and raisins, whereas cinnamon, cloves, ginger, mace, nutmeg, and pepper were the spices used most often.

If sugar or extra honey were available, the housewife might prepare stillroom sweets such as whole fruit preserved in sugar syrup, or marmalade—a dense, jam-like product made with sieved fruit. Vinegar figured prominently among condiments, along with mustard, horseradish, anchovies, and two meat accompaniments standard today: applesauce with pork, mint with lamb.

Considering water unhealthy unless converted into soups and broths, yeomen drank cider, ale, and beer. The popular apple cider and perry (pear cider) spoiled quickly, thus were seasonal. Families typically made weekly supplies of "small ale," unhopped beer with a

⁴⁵ Drummond and Wilbraham, *Englishman's Food*, pp. 111, 125.

low alcoholic content. When hops were available the yeoman could make beer or porter—a very strong, almost black, heavily hopped beer. Yeomen with bees might make honey into mead. Since England was not a grape country, only wealthier people drank wine; the most common strong spirit was aquavita, a crude brandy like raw gin.

Dinner provided the heaviest meal of the day; supper, the lightest. Breakfast might include brown bread, cheese, and ale. At its most luxurious, a midday dinner would offer a meat pie or a roast (mutton, beef, chicken), bread, cheese, ale, and a fruit tart; more modest and typical dinner fare might include bread, pease porridge, and ale in the winter, or salad, eggs, and fruit in the summer. Supper could be as light as milk cooked with raisins, accompanied by roasted apples dipped in mead.⁴⁶

Rarely offering more than three dishes, the yeoman's meals appeared in a single course. Individual foods retained their identities, with flavors and textures undisguised and untransformed. Eaten from porringers or wooden trenchers with wooden spoons and sharp-pointed knives, more likely served communally than individually, the foods were simple and uncontrived: coarse bread, cheese, legume pottages, salted meat and fish, sallet vegetables, stewed fruit, puddings, cider, and ale.

⁴⁶ Mildred Campbell, *The English Yeoman Under Elizabeth and the Early Stuarts* (1942; rpt. New York: Augustus M. Kelley, 1968), p. 249.

VIRGINIA'S ABORIGINAL CUISINE

Indians in seventeenth-century Virginia followed a resourceful regimen of food gathering and growing, cooperating with nature's seasonal vagaries, indulgent in plenteous periods and abstemious in lean. That harmonious and superficially effortless style of food procurement awed the first English visitors and often saved them from hunger. Their ships' stores depleted and infested, unable to plant and harvest "instant crops," lacking skills and motivation for catching the natural game and seafood, the Elizabethan adventurers welcomed the natives' hospitality and trade. John Smith writes,

The next night being lodged at Kecoughtan 6 or 7 daies [in December 1608], the extreame wind, raine, frost, and snowe, caused us to keepe Christmas amongst the Salvages, where wee were never more merrie, nor fedde on more plentie of good oysters, fish, flesh, wildfoule, and good bread, nor never had better fires in England then in the drie warme smokie houses of Kecoughtan.⁴⁷

The settlers quickly accepted and adopted the Indians' chief dietary staple: maize. New to the English, Indian corn offered advantages of easy cultivation, multiple crops within a single season, high yields, practical preservation and storage, and adaptability. By planting corn as early as March, the Indians could harvest two crops from one field in a single season. The fresh young corn yielded both

⁴⁷ John Smith, "The Proceedings of the English colony in Virginia," in *The Extension of Settlement in Florida, Virginia, and the Spanish Southwest*, Vol. 5 of *New American World*, ed. David B. Quinn (New York: Arno Press, 1979), pp. 328-29.

roasting ears and a sweet juice "somewhat like a suger Cane" which the Indians sucked from the stalks.⁴⁸ Robert Beverley writes, "They delight much to feed on Roasting-ears; that is, the *Indian Corn*, gathered green and milky, before it is grown to its full bigness, and roasted before the Fire, in the Ear."⁴⁹

Green corn also appeared in stew-like mixtures throughout the season. The Indians dried later, mature corn in hot ashes; then in winter they boiled the dried corn with beans, meat, or fish in the ubiquitous hominy pot. Unlike our contemporary hominy treated with alkali, the Indians' hominy was simply dried corn soaked, pounded in a mortar, husked, and then boiled for as long as twelve hours to a porridge consistency; many writers describe hominy as like furmenty, wheat boiled in milk. Beverley writes that "The thin of this is, what my Lord *Bacon* calls Cream of Maize, and highly commends for an excellent sort of nutriment."⁵⁰

⁴⁸ John Smith, *A Map of Virginia* (Oxford, 1612; rpt. Amsterdam: Theatrum Orbis Terrarum, 1973), p. 16-17. Smith provides a comprehensive description of the Indians' food. Extensive accounts are also given by Robert Beverley, *The History and Present State of Virginia* (1705), ed. Louis B. Wright (Chapel Hill: Univ. of North Carolina Press, 1947); Thomas Harriot, "A briefe and true report of the new found land of Virginia (1588), as reprinted by Hakluyt in 1589," in *Virginia Voyages from Hakluyt*, ed. David B. Quinn and Alison M. Quinn (London: Oxford Univ. Press, 1973); and John Lawson, *A New Voyage to Carolina* (1709), ed. Hugh Talmage Lefler (Chapel Hill: Univ. of North Carolina Press, 1967).

⁴⁹ Beverley, *History*, p. 180.

⁵⁰ Beverley, *History*, p. 178.

For bread, corn was pounded more finely than for hominy, but still with a soaking process to soften the intractably hard corn. Archaeologists have found evidence that the Indians used two stones to grind corn—one larger and dish shaped serving as a mortar, one smaller and rounded serving as a pestle. John Lawson gives this description, however, of the use of a large wooden mortar:

The Savage Men never beat their Corn to make Bread; but that is the Womens Work, especially the Girls, of whom you shall see four beating with long great Pestils in a narrow wooden Mortar; and every one keeps her Stroke so exactly, that 'tis worthy of Admiration.⁵¹

Smith explains in greatest detail the processing of corn:

Their old wheat [corn] they first steep a night in hot water, in the morning pounding it in a mortar. They use a small basket for their Temmes, then pound againe the great, and so separating by dashing their hand in the basket, receive the flower in a platter made of wood scraped to that forme with burning and shels. Tempering this flower with water, they make it either in cakes covering them with ashes till they bee baked, and then washing them in faire water they drie presently with their owne heat: or else boyle them in water eating the broth with the bread which they call *Ponap*. The grouts and peeces of the cornes remaining, by fanning in a Platter or in the wind, away, the branne they boile 3 or 4 houres with water, which is an ordinary food they call *Ustatahamen*. But some more thrify then cleanly, doe burne the core of the eare to powder which they call *Pungnough*, mingling that in their meale, but it never tasted well in bread, nor broth.⁵²

George Percy observes that after the Indians pounded corn into flour, mixed the flour with water to make a paste, and boiled lumps of the paste, they "hardened" the bread by placing it on a smooth stone or

⁵¹ Lawson, *New Voyage*, p. 216.

⁵² Smith *Map*, p. 17.

baking it in an oven.⁵³ According to Beverley, the Indians baked bread "either in Cakes before the Fire, or in Loaves on a warm Hearth, covering the Loaf first with Leaves, then with warm Ashes and afterwards with Coals over all."⁵⁴

Corn had one more use: a traveler's meal called *Rockahomonie*, parched corn beaten to a fine powder. When traveling with limited food (or with no time for preparing food), a hungry Indian could place in his mouth a spoonful of the fine meal, drink "a draught of Water upon it," and thus fortified move on without delay.⁵⁵

Many foods, especially nuts, seeds, wild grains, and roots, served as bread—a term denoting generic food rather than our sort of grain loaf. Acorns, chestnuts, and chinquapins were boiled, pounded, and made into bread much like the lumps of pounded corn "seethed" and "sodden." Sunflower seeds were ground into a flour for bread, and a wild grain similar to rye was used for "a dainty bread buttered with deare suet."⁵⁶

The Indians also made bread of roots like Tuckahoe, a marsh plant.

The chiefe roote they have for foode is called *Tockwhoughe*, It groweth like a flagge in low muddy freshes. In one day a *Savage* will gather sufficient for a weeke. These rootes are much of the greatnes & taste of

⁵³ George Percy, *Observations Gathered out of "A Discourse of the Plantation of the Southern Colony in Virginia by the English, 1606,"* ed. David B. Quinn (Charlottesville: Univ. Press of Virginia, 1967), p. 21.

⁵⁴ Beverley, *History*, p. 178.

⁵⁵ Beverley, *History*, p. 185.

⁵⁶ Smith, *Map*, p. 12.

Potatoes. They use to cover a great many of the[m] with oke leaves & ferne, and then cover all with earth in the manner of a colepit; over it, on each side, they continue a great fire 24 hours before they dare eat it. Raw it is no better then poison, & being roasted, except it be tender and the heat abated, or sliced and dried in the sun, mixed with sorrell and meale or such like, it will prickle and torment the throat extreamely, and yet in sommer they use this ordinarily for bread.⁵⁷

Ground-nuts and yams or sweet potatoes also contributed to the native diet, along with a great variety of peas, beans, squashes, and melons. The peas and beans were eaten fresh, cooked with meat or fish, or dried and simmered in winter stews. Hard-shelled squashes such as pumpkins were generally boiled; other squashes and melons were sometimes cooked in mixtures with meat or fish, sometimes eaten raw. Indians avoided the rampant wild onions, but they did use other plants as seasonings, especially a root called Habascon, perhaps a cow-parsnip.⁵⁸ Hickory ashes or the residue of burned Melden stalks (orach or salt-bush) served as salt substitutes.⁵⁹

While acorns, chestnuts, and chinquapins went often into bread or stews, hickory nuts made an unusual soup or milk. As Colonel Norwood lyrically describes,

It was a sort of spoon-meat, in colour and taste not unlike to almond-milk temper'd and mix'd with boiled rice. The ground still was *Indian* corn boiled to a pap, which they call *Homini*, but the ingredient which performed the milky part, was nothing but dry pokickery nuts, beaten shells and all to powder, and they are like our walnuts, but thicker shell'd, and the kernel sweeter; but being beaten

⁵⁷ Smith, *Map*, p. 13.

⁵⁸ Harriot, *A briefe and true report*, p. 60.

⁵⁹ Beverley, *History*, p. 180; Harriot, *A briefe and true report*, p. 56.

in a mortar, and put into a tray, hollow'd in the middle to make place for fair water, no sooner is the water poured into the powder, but it rises again white and creamish; and after a little ferment it does partake so much of the delicate taste of the kernel of that nut, that it becomes a rarity to a miracle.⁶⁰

Lawson recounts a simpler treatment in which hickory shells and kernels were pulverized and the powder presented in "little wooden Dishes. . . . the Kernel dissolves in your Mouth, and the Shell is spit out. This tastes as well as any Almond." Of another soup, beaten hickory nuts and venison broth, he says the nut dissolved and thickened while its shell precipitated to the bottom.⁶¹

The Indians also prepared deer, their chief meat, in diverse ways. A venison soup resembled, according to Beverley, the *jus nigrum* of the Spartans: "the head and Umbles of a Deer, which they put into the Pot all bloody."⁶² The rest of the deer might be dried like beef jerky, stewed with hominy, or barbecued (broiled). Early accounts give varied descriptions of the Indian broiling, or barbecuing technique. Sometimes the meat was laid directly on hot coals, sometimes on hurdles (gridiron-like frames of green reeds or canes), sometimes on skewers. John Clayton explains another "barbecuted" venison as "wrapped up in leaves and roasted in the Embers."⁶³

⁶⁰ Colonel Norwood, "A Voyage to Virginia" (1650), in *Tracts and Other Papers*, ed. Peter Force, Vol. III, No. 10 (1844; rpt. New York: Peter Smith, 1947), p. 37.

⁶¹ Lawson, *New Voyage*, p. 105.

⁶² Beverley, *History*, p. 180.

⁶³ *The Reverend John Clayton, A Parson with a Scientific Mind*, ed. Edmund Berkeley and Dorothy Smith Berkeley (Charlottesville: Univ. Press of Virginia, 1965), p. 37.

Telling how an Indian king presented fresh venison and invited him to cut and cook the meat to his own pleasure, Colonel Norwood gives this instructive exposition:

I could not readily tell how to shew my skill in the cookery of it, with no better ingredients then appear'd in sight; and so did no more but cut a collop [slice] and cast it on the coals. His majesty laugh'd at my ignorance, and to instruct me better, he broach'd the collop on a long scewer, thrust the sharp end into the ground . . . and turning sometimes one side, sometimes the other, to the fire, it became fit in short time to be served up, had there been a dining-room of state such as the excellent king deserved. . . . The rest of the doe was cut in pieces, stewed in a pipkin, and then put into my hands to dispose of amongst my company.⁶⁴

Barbecued turkey was also popular, along with other wild fowl, possum, raccoon, rabbit, otter, and squirrel. The Indians thought beaver's tail a great delicacy and especially valued bear—both the meat and the fat. Strachey writes that so greedily did the Indians hunt bears and love them above all flesh, that the English could rarely obtain bears in trade.⁶⁵ Turtle was standard fare; all kinds of fish, a staple. Fish, like venison, was preserved by drying—either by slow smoking at the side of a fire, or by barbecuing on hurdles, then pulling into shreds and drying in the sun.⁶⁶ Plentiful oysters and other shellfish were also roasted and dried, as well as cooked in stews—even sometimes combined with turkey or other meats. Strachey

⁶⁴ Norwood, "Voyage," p. 38.

⁶⁵ William Strachey, "Historie of Travaile into Virginia Britannia," in *Extension of Settlement*, pp. 354-55.

⁶⁶ Barbecuing fish on a hurdle is illustrated in de Bry's engraving of a John White watercolor painting; see Thomas Harriot, *A Briefe and True Report of the New Found Land of Virginia* (Frankfurt, 1590; rpt. New York: Dover, 1972), p. 59.

gives this description:

The salvages use to boyle oysters and mussells together, and with the broath they make a good spoone meat, thickned with the flower of their wheat; and yt is a great thrift and husbandry with them to hang the oysters upon strings (being shauld and dried) in the smoake, thereby to preserve them all the yeare.⁶⁷

Appropriately, considering the bounty and importance of oysters in Tidewater, that shellfish introduced New World gastronomy to the English. Percy writes that upon a first arrival in the Chesapeake Bay,

We came to a place where [the Indians] had made a great fire, and had been newly roasting oysters. When they perceived our coming, they fled away to the mountains, and left many of the oysters in the fire. We ate some of the oysters, which were very large and delicate in taste.⁶⁸

The Indians not only enjoyed Tidewater's bounty of fruits as they came into season, but dried or preserved them for the winter. Strawberries, raspberries, hurts (blueberries), and mulberries either burgeoned underfoot or dropped from the trees. Smith describes a medlar-like fruit dried and preserved "as Pruines," berries like capers which were dried after much boiling to acquit a poisonous nature, a berry like the gooseberry (perhaps really an unripe cranberry) eaten raw or boiled, and passion flower fruit—*Maracocks*, a "pleasant wholesome fruit much like a lemond."⁶⁹ Peaches were barbecued, made into bread, dried, and converted into *Quiddony*—a thick fruit syrup

⁶⁷ Strachey, "Historie," p. 356.

⁶⁸ Percy, *Observations*, pp. 8-9.

⁶⁹ Smith, *Map*, p. 12.

or jelly. Lawson writes that *Quiddony* was made "into Loves like Barley-Cakes, these cut into thin Slices, and dissolved in Water," making a "grateful acid" with medicinal powers.⁷⁰

Joining fruit as a sweetener was maple syrup, or maple sugar. Beverley gives this description:

The Sugar-Tree yields a kind of Sap or Juice, which by boiling is made into Sugar. This Juice is drawn out, by wounding the Trunk of the Tree, and placing a Reviever under the Wound. The *Indians* make One Pound of Sugar, out of Eight Pounds of the Liquor. Some of this Sugar I examined very carefully. It was bright and moist, with a large full Grain; the Sweetness of it being like that of good Muscovada [unrefined sugar].⁷¹

Beverley's history, our earliest comprehensive and balanced account of Virginia's first century, has sometimes led later writers to faulty assumptions such as that early Virginia settlers used maple syrup. Beverley himself lived near the falls of the James River late in the century, when new settlements were moving toward the piedmont frontier and away from Tidewater. The fur trade had brought men like William Byrd (Beverley's father-in-law) into contact with Indians from the west, from the higher, colder natural environment of the mountains where maple sap flows. Although seventeenth-century winters were colder than today's, maple sugar production on the coast seems unlikely, especially since earlier observant writers like Harriot and Smith do not mention it.

⁷⁰ Lawson, *New Voyage*, p. 24.

⁷¹ Beverley, *History*, p. 136.

Despite the resourcefulness and practicality of the Indians' food gathering and preparation, Virginia's aboriginal cuisine apparently exerted little influence on the early settlers apart from their wholehearted acceptance of corn. Corn became the chief food for poorer settlers, just as indigenous grains and pulse served as dietary mainstay for the poorer English. The settlers adopted the Indians' methods of growing and processing corn: planting in hills, drying, pounding into hominy, grinding into flour. While the settlers apparently cooked hominy in styles reminiscent of English pottages, they made corn meal into Indian breads—perhaps because corn simply could not be used in familiar English breads. The first Virginia settlers grew English vegetables, made English puddings, and watched English livestock thrive. Once past the initial struggle for survival when the Indians provided life-saving food supplies, colonists began generally to view Indians as heathens and enemies, and to drive them from the coastal region. Probably only the English living in more primitive frontier settings—men living alone on the smallest plantations, trappers moving west—adopted Indian styles of food preparation. Most settlers maintained as many English culinary traditions as possible.

Section II. FINDINGS

INTRODUCTION

The next four chapters present research findings which identify and describe available foods, cooking facilities and equipment, food preparation methods, and dining customs of seventeenth-century Virginia. County court records and archaeological artifacts provided the more original findings, information not previously uncovered or focused in a study of cuisine. Although many researchers have examined county court records, no published studies have analyzed the probate inventories for mention of foods, cooking facilities, and cooking equipment present in households. Similarly, although archaeologists and anthropologists have studied food-related artifacts from seventeenth-century sites, studies have not linked artifacts with patterns of inventory data or focused on the role of artifacts in the cuisine.

Because most extant county records for seventeenth-century Virginia cover only intermittent or brief time periods, York and Surry county records were chosen for an analysis of probate inventories—York County because its records cover the longest continuous time period, 1638 through the end of the century, and Surry County because its records cover a comprehensive period from 1663.

Randle Holme's *Academy of Armory* served as both documentary and iconographic reference, providing drawings of household objects

and also naming and describing them in seventeenth-century terminology.¹ Because Dutch daily life resembled English life during the early seventeenth-century, Dutch genre and still-life paintings from the sixteenth and seventeenth centuries illustrate many objects comparable to artifacts found in Virginia.²

The writings of Virginia's early adventurers and settlers, travelers' accounts, and planters' correspondence provided information on available foods, food preparation techniques, and dining customs. More interested in Indian life than in familiar English ways, early writers give more descriptions of native food than of colonists' food, more attention to cataloging natural plants and animals than to describing home gardens and domestic livestock. Most archival correspondence concerns business arrangements, not daily life, and archives yield no letters or diaries written by women in seventeenth-century Virginia.

The nature of available sources—rich in information about physical possessions, weak in descriptions of activities, styles, and values—limits the comprehensiveness of the research findings.

¹ Part of Holme's work (through Book 3, Chap. 13) was published in 1688, but a later edition (of Book 3, Chap. 14, through Book 4, Chap. 13) includes most references to household objects. See Randle Holme, *Academy of Armory*, ed. I. H. Jeays (London: Roxburghe Club, 1905).

² No pictorial records exist for seventeenth-century Virginia, apart from White's watercolor paintings of Indians, and English painters of the period did not depict daily life. Audrey Noel Hume explained the Noel Humes' use of Dutch paintings as iconographic reference for their representations of daily life at Wolstenholme Towne in an interview at Williamsburg, 18 February 1981.

Additional studies may, however, uncover new data and new relationships among data.

Chapter 4

THE FOOD SUPPLY

The three ships that landed at Jamestown on 14 May 1607 bore a company of adventurers unprepared for either settlement or survival. Like construction workers on the Alaskan pipeline, the Virginia Company men sought immediate riches from a commercial venture: the exploitation of natural resources. Expecting periodic shipments of food supplies from home, those Englishmen did not intend initially to establish self-sufficient settlements; they saw themselves as sojourners, not as residents.

The standard seafarer's diet of salted fish and meat, barley and oats, rancid butter and cheese, biscuit, and crude spirits hardly promised epicurean comforts—especially when a voyage from England to Virginia took months and when those tiny ships lacked refrigerators and freezers. Even livestock shipped to the colony must have arrived at best worn and emaciated. After recounting the deaths of company members when the ships returned to England and left the colonists in Virginia, George Percy succinctly states the early dietary situation:

Our food was but a small can of barley, sod in water, to five men a day, our drink, cold water taken out of the river, which was at a flood [high tide] very salt, at a low tide full of slime and filth, which was the destruction of many of our men.¹

¹ *Observations Gathered out of "A Discourse of the Plantation of the Southern Colony in Virginia by the English, 1606,"* ed. David B.

Characteristically, John Smith provides a more colorful and detailed account:

Being thus left to our fortunes [at the departure of the ships], it fortun'd that within tenne daies scarce ten amongst us coulde either goe, or well stand, such extreame weaknes and sicknes opressed us. And thereat none need marvaile, if they consider the cause and reason, which was this; whilst the ships staid, our allowance was somewhat bettered, by a daily proportion of bisket whch the sailers would pilfer to sell, give or exchange with us, for mony, saxefras, furre, or love. But when they departed, there remained neither taverne, beere-house nor place of relief but the common kettell. Had we beene as free from all sinnes as gluttony, and drunkennes, we might have bin canonized for Saints; But our President would never have bin admitted, for ingrossing to his privat, Otemeale, sacke, oile, aquavite, beefe eggs, or what not, but the kettel; that indeede he allowed equally to be distributed, and that was halfe a pinte of wheat and as much barly boyled with water for a man a day, and this having fryed some 26. weeks in the ships hold, contained as many wormes as graines; so that we might truely call it rather so much bran then corne, our drinke was water, our lodgings castles in aire. . . . From May to September, those that escaped; lived upon Sturghion, and sea-Crabs. . . .²

The natural bounty and the Indians' generosity and trade did, however, bring some relief from hunger.

And now the winter approaching, the rivers became so covered with swans, geese, duckes, & cranes, that we daily feasted with good bread, Virginia pease, pumpions, and putchamins, fish, fowle, and diverse sorts of wild beasts as fat as we could eat them. . . .³

Quinn (Charlottesville: Univ. Press of Virginia, 1967), p. 26.

² John Smith, "The Proceedings of the English colony in Virginia," in *The Extension of Settlement in Florida, Virginia, and the Spanish Southwest*, Vol. 5 of *New American World*, ed. David B. Quinn (New York: Arno Press, 1979), p. 313.

³ Smith, "Proceedings," p. 314.

The variable quality of life reached its nadir with the "Starving Time" of 1609, when disease, discord, sloth, and simple hardship dreadfully weakened and reduced the population.⁴ The more lurid tales of the Starving Time concern cannibalism, especially the case of the man who salted away his wife as a fleshy provision. Later writers have most often quoted Stith's eighteenth-century history,⁵ but Stith apparently lifted his version from Smith:

[S]o great was our famine, that a Salvage we slew and buried, the poorer sort tooke him up againe and eat him; and so did divers one another boyled and stewed with roots and herbs: And one amongst the rest did kill his wife, powdered [*salted*] her, and had eaten part of her before it was knowne; for which hee was executed, as hee well deserved: now whether shee was better roasted, boyled or carbonado'd, I know not; but of such a dish as powdered wife I never heard of.⁶

Strachey later attempted to clarify the story by relating Sir Thomas Gates' testimony:

'There was one of the company who mortally hated his wife and therefore secretly killed her, then cut her in pieces and hid her in divers parts of his house. When the woman was missing, the man [was] suspected, his house searched, and parts of her mangled body were discovered. To excuse himself he said that his wife died, that he hid her to satisfy his hunger, and that he fed daily upon her. Upon this, his house was again searched, where they found a good quantity of meal, oatmeal, beans, and peas.

⁴ Carville V. Earle has persuasively argued that disease, not widespread hunger, caused high mortality among early Virginians. See "Environment, Disease, and Mortality in Early Virginia," in *The Chesapeake in the Seventeenth Century*, ed. Thad W. Tate and David L. Ammerman (New York: W. W. Norton, 1979), pp. 96-125.

⁵ W. William Stith, *The History of the First Discovery and Settlement of Virginia* (1747; rpt. Spartanburg, S. C.: Reprint Company, 1965) pp. 116-17.

⁶ *Travels and Works of Captain John Smith*, ed. Edward Arber and A. G. Bradley (Edinburgh: John Grant, 1910), II, 498-99.

He thereupon was arraigned, confessed the murder, and was burned for his horrible villainy.'⁷

Although modern sensibilities sometimes discount the Jamestown cannibalism stories as apochryphal, early writers report similar incidents in other hardship-ridden situations. According to Colonel Norwood's account of a shipwreck en route to Virginia, the stronger survivors resorted to eating the corpses of weaker fellows, adhering fastidiously to a policy in which women ate only women and men ate only men.⁸ When a sixteenth-century English expedition in the North Atlantic floundered and ran out of supplies, the starving explorers became cannibals even in midsummer when ripe berries and plentiful salmon offered a ready food source; Smith also describes an incident of cannibalism at sea.⁹

Although for several years supplies from England provided only intermittent relief in the struggle to maintain a food supply, the colony gradually developed some self-sufficiency with crops and livestock. New plantations were established, the first women arrived in 1619, and after the dissolution of the London Company in 1624 daily life completed its shift from a military regimen to a household-based order. Only at mid-century did agriculture move beyond the

⁷ William Strachey, "A True Reportory of the Wreck and Redemption of Sir Thomas Gates, Knight, upon and from the Islands of the Bermudas" (1610), in *A Voyage to Virginia in 1609*, ed. Louis B. Wright (Charlottesville: Univ. Press of Virginia, 1964), p. 98.

⁸ Colonel Norwood, "A Voyage to Virginia" (1650), in *Tracts and Other Papers*, ed. Peter Force, Vol. III, No. 10 (1844; rpt. New York: Peter Smith, 1947), pp. 24-25.

⁹ Carl Ortwin Sauer, *Sixteenth Century North America* (Berkeley: Univ. of California Press, 1975), pp. 233-34; Smith, *Travels*, II, 651.

struggle-for-subsistence stage; in fact, during the early years settlers demonstrated such immoderate greed in their concentration on tobacco planting that the government had to force them to grow food as well as tobacco. Although never rivaling tobacco in production, corn served as the main food crop, followed by much smaller quantities of peas and beans. Private gardens provided individual households with vegetables and fruit, but not with produce for trade. Despite inferior care, cattle, goats, hogs, and poultry increased.

Documentary records provide most of the evidence of foods available in early Virginia, although archaeological studies are beginning to give new information on food patterns and the relation of diet to status. Probate inventories routinely enumerate livestock among estate possessions, but data about other foods appear only sporadically in court records. Staple foods such as salt, sugar, dried legumes, and dried meat occasionally appear in estate inventories, whereas store inventories and shipping invoices usually include mention of sugar, salt, spices, and spirits. Planters' business correspondence sometimes mentions orders for food items or discusses farming issues such as orchards and grain mills. Tables 1, 2, and 3 (which follow) present data from estate inventories, then subsequent sections of this chapter discuss available foods in these categories: meats and poultry, fish and shellfish, grains, vegetables, fruits, dairy products, fats and oils, beverages, sweeteners, condiments and seasonings. Then follows a discussion of the diets of slaves.

Appendix B includes excerpts from the printed primary sources which provide most of the available information on seventeenth-century Virginia's food supply.

Table 1. Mention in Estate Inventories of Foods and Food-Producing Animals, York County Court Records, 1638-1699

	1630- 1639*	1640- 1649	1650- 1659	1660- 1669	1670- 1679	1680- 1689	1690- 1699
	N=1	N=8	N=19	N=27	N=33	N=44	N=54
FOODS							
Corn	1	2	9	6		10	7
Wheat			2	6		4	2
Peas			1	2			
Beans			2	2		1	1
Dried beef			1		3		
Dried pork			1		2		
Sugar			1	2		3	1
Salt			3	2	7	6	5
Pepper			1	1	4	1	1
Spices					3	3	1
Nutmeg				1	2		
ANIMALS							
Cattle		5	13	20	21	36	43
Hogs		2	10	16	5	15	19
Sheep				4		4	10
Goats	1				1		
Poultry		1	3	1			1
Turkeys			1	2	1		
Bees				2	1		2

*The single inventory for this decade is dated 1638.

Table 2. Mention in Estate Inventories of Foods and Food-Producing Animals, Surry County Court Records, 1663-1699

	1663- 1669 N=4	1670- 1679 N=32	1680- 1689 N=32	1690- 1699 N=36
FOODS				
Corn		9	14	12
Wheat		4	8	4
Oats		1	3	3
Barley		1	2	
Peas		1	1	
Beans		1		2
Dried beef		1	2	1
Bacon		2	8	2
Salt		5	6	5
ANIMALS				
Cattle		23	27	35
Hogs		20	27	30
Sheep		1	4	14
Poultry		1	3	5
Turkeys		1	1	1
Bees			1	1

Table 3. Foods, Beverages, and Food-Producing Animals
Infrequently Mentioned in Estate Inventories from
County Court Records

<u>York County</u> (1638-1699)	<u>Surry County</u> (1663-1699)
FOODS	FOODS
Meal	Dried meal
Barley	Sugar
Oats, oatmeal	Molasses
Flour, English flour	Pork
Brown sugar	Beef
White sugar	Dried meat
Honey	Pepper
Treacle	Ginger
Molasses	
Lime juice	
Meat	
Bacon	
Hog's lard	
Oil	
Butter	
Bay salt	
Ginger	
Cloves and mace	
Currants	
Raisins	
Prunes	
Vinegar	
BEVERAGES	BEVERAGES
Cider	Rum
Perry	Hops
Strong liquors	
Spirits	
Brandy	
Aquavita	
Wine	
ANIMALS	ANIMALS
Ducks	Ducks
Geese	Geese

MEATS AND POULTRY

Beef and pork ranked first among desirable meats in Virginia, followed by poultry "without number," game, and some mutton. Although English yeomen enjoyed meat only infrequently, Durand writes in 1687 that in Virginia "there is not a house so poor that they do not salt an ox, a cow & five or six large hogs."¹⁰ Cattle first served as dairy and draft animals, then as a meat source; therefore cattle were generally slaughtered for meat only after the other needs were met—only when the number of animals exceeded those needed for labor and milk, or when older, weaker animals lost usefulness for field and dairy. Settlers usually slaughtered beef for drying and salting in late fall, when weather was cooler and cattle still fat from summer grazing.

Although beef—except for the delicate veal—must have been often less than excellent, early writers unanimously praise Virginia's pork as equal or superior to the finest in the world, usually noting that hogs which ran wild ate copious quantities of nuts while the domestic swine gorged on peaches and other orchard bounty. Hogs were so numerous that estate appraisers often either did not bother to count them or reported "hogs running wild in the woods."

¹⁰ [Durand, of Dauphine], *A Huguenot Exile in Virginia*, ed. Gilbert Chinard (The Hague, 1687; rpt. New York: Press of the Pioneers, 1934), p. 123.

Although goats appear prominently in early statements of livestock in the colony, they appear infrequently in inventories.¹¹ Records give little indication of the extent to which goats provided milk and meat, but their number apparently declined later in the century—perhaps because they were a nuisance, doing "mischief" to orchards. Inventories do mention sheep, although much less frequently than cattle and hogs; sheep apparently were grown for wool only late in the century when self-sufficiency began to include production of textiles, so the earlier sheep must have served primarily as a meat source, possibly as a milk source.

Domestic poultry chiefly included chickens; some households kept ducks, geese, and turkeys. Although domestic fowl surely provided eggs, documentary sources ignore both the presence and use of eggs. Early writers often remark on the proliferation and great size—forty to sixty pounds—of wild turkeys, as well as on the great abundance and variety of other wild fowl. The catalogue of game fowl includes pheasant, partridges, woodcock, doves, turtle doves, thrushes, pigeons, larks, crows, eagles, ducks, geese, swans, widgeons, teals, cranes, and gulls.

Water fowl proved especially easy to shoot; early accounts suggest a hunter could down several ducks or geese with a single shot. Of all the early chroniclers, Lawson expresses the most interest

¹¹ See, for example, the list of livestock in John Rolfe, *A True Relation of the State of Virginia Lefte by Sir Thomas Dale Knight in May Last 1616* (Charlottesville: Univ. Press of Virginia, 1971), pp. 14-15.

in the aesthetic qualities of fowl; he pronounces many varieties as "dainty meat" or "as good as ever I eat," but cranes—which made the best broth—were "very hard to digest."¹² Although writers interested in natural history delight in giving extensive lists of birds, one wonders about the extent to which busy planters pursued small "dainty-meated" birds. Durand says even of domestic fowl, "Pigeons are raised only by people of quality, the common people scorning such small animals."¹³

Of the game animals used for food, deer figured so prominently that some writers complain of venison's boring omnipresence on Virginia tables. Durand says venison was "very good in pies, boiled or baked," applauds beaver and raccoon, and mentions rabbits as like the ones in Europe.¹⁴ Wodenoth pronounces raccoon "as good meat as Lambe," but Lawson has reservations about possum: whereas it "tasted much between young Pork and Veal" and had white flesh and fat, "their ugly Tails put me out of Conceit with that Fare."¹⁵

Although few bears roamed the inhabited part of Virginia, their meat was "commended for a very ritch sort of Pork" and was given this enthusiastic praise:

¹² John Lawson, *A New Voyage to Carolina* (1709), ed. Hugh Talmage Lefler (Chapel Hill: Univ. of North Carolina Press, 1967), pp. 142-55.

¹³ Durand, *Huguenot Exile*, p. 122.

¹⁴ Durand, *Huguenot Exile*, p. 123.

¹⁵ Richard Wodenoth, "A Perfect Description of Virginia," in *Tracts and Other Papers*, p. 16; Lawson, *New Voyage*, pp. 33, 125-26.

The Flesh of this Beast is very good, and nourishing, and not inferiour to the best Pork in Taste. It stands betwixt Beef and Pork, and the young Cubs are a Dish for the greatest *Epicure* living. I prefer their Flesh before any Beef, Veal, Pork, or Mutton; and they look as well as they eat, their fat being as white as Snow, and the sweetest of any Creature's in the World. If a Man drink a Quart thereof melted, it never will rise in his Stomach. We prefer it above all things, to fry Fish and other things in. Those that are Strangers to it, may judge otherwise; But I who have eaten a great deal of Bears Flesh in my Life-time (since my being an Inhabitant in *America*) do think it equalizes, if not excels, any Meat I ever eat in *Europe*.¹⁶

Finding turtles commonplace, early settlers ate both the veal-like meat and the eggs. The Swiss traveler Michel observes at the turn of the century that turtles were "gathered and eaten by the negroes or slaves," showing that a natural source of meat could provide epicurean foods for people without livestock or income.¹⁷

FISH AND SHELLFISH

Virginians valued fish and shellfish as much for their adaptability to salting and pickling as for their immediate, fresh contribution to the food supply. Of the fish abounding in the bay and rivers of Chesapeake, sturgeon was especially noticed and valued by the earliest colonists; later settlers admired sheephead and drum. Although he

¹⁶ *The Reverend John Clayton, a Parson with a Scientific Mind*, ed. Edmund Berkeley and Dorothy Smith Berkeley (Charlottesville: Univ. Press of Virginia, 1965), p. 109; Lawson, *New Voyage*, p. 121.

¹⁷ "Report of the Journey of Francis Louis Michel from Berne, Switzerland, to Virginia, October 2, 1701–December 1, 1702," trans. and ed. William J. Hinke, *Virginia Magazine of History and Biography*, 24 (1916), 42.

found other fish equally as good, Lawson describes sheepshead as "a very delicate Fish, and well relish'd"; Wodenoth notes that it "makes broath so like Mutton-broath, that the difference is hardly known."¹⁸ While noting that the red drum was the most abundant of all fish, with "good firm Meat," Lawson says "the Head is beyond all the Fish I ever met withal for an excellent Dish"; he also remarks the glories of soused [pickled] bass heads.¹⁹ Other fish varieties frequently mentioned include herring, mackerel, trout, bluefish, bream, bonito, shad (denigrated for its abundance of small bones), oldwives, mullets, plaice, flounder, sole, perch, cod, ray, and croaker. Reporting guardfish eschewed by the English but favored by the Indians, Lawson also dismisses shark as desirable only when other food was scarce; he mentions eels as both common and good.²⁰

Of the shellfish, oysters were as popular as prolific, partly because of the ease with which they could be harvested, eaten raw, steamed, cooked with other foods, or pickled. Although crabs, scallops, clams, shrimp, horseshoe crabs, muscles, periwinkles, cockles, and crayfish also provided ready food, they never matched oysters in popularity.

¹⁸ Lawson, *New Voyage*, p. 163; Wodenoth, "Perfect Description," p. 17.

¹⁹ Lawson, *New Voyage*, pp. 159, 163.

²⁰ Lawson, *New Voyage*, pp. 158, 163.

GRAINS

In addition to freedom, a suit of clothes, and tools, indentured servants received at the end of their terms three barrels of corn—a year's supply of food. In seventeenth-century Virginia, Indian corn provided not merely the chief grain for bread, but the chief food. Although the diet gained variety as agriculture developed during the century, no other food surpassed corn in practicality. Corn was easy to grow, easy to dry and preserve; it kept well and adapted to a variety of uses—fresh vegetable, hominy to make porridge or serve as a base for mixed dishes, meal for breads. Corn, like barley, could also be malted for beer or distilled spirits.

Virginians grew other grains, but in lesser quantities. Wheat required broadcast seeding, and its harvest and milling were more difficult than corn's. Noting at the end of the century that wheat bread was served regularly at "gentlemen's houses," Beverley writes,

some rather choose the Pone, which is the Bread made of *Indian* Meal. Many of the poorer sort of People so little regard the *English* Grain, that though they might have it with the least trouble in the World, yet they don't mind to sow the Ground, because they won't be at the trouble of making a Fence particularly for it. And therefore their constant Bread is Pone, not so called from the Latine, *Panis*, but from the *Indian* Name *Oppone*.²¹

²¹ Robert Beverley, *The History and Present State of Virginia*, ed. Louis B. Wright (Chapel Hill: Univ. of North Carolina Press, 1947), p. 292.

Of that pone, Durand said it was as "white as paper & agreeable to the taste, but rather heavy on the stomach for those not used to it, nor can the dough be spread to make pies."²²

Both barley and oats sometimes appear in estate inventories, but with even less frequency than wheat; they are rarely mentioned in documentary sources. For instance, William Fitzhugh writes that at his plantation he had "a good water Grist miln, whose tole I find sufficient to find my own family with wheat & Indian corn for our necessitys and occasions."²³ Clearly, only corn and wheat figured as major grains, and corn's greatest value of all was that "one careful laborious man will plant, tend, and get in 50. barreles of Indian Wheat, without the help of Man, Horse or Oxe. . . ."²⁴

VEGETABLES

Both natural and cultivated vegetables and herbs flourished in Virginia. Although Indians taught the settlers how to grow corn and introduced them to native varieties of beans, peas, and squash, the English apparently did not imitate the natives in use of wild plants—especially the marsh plants the Indians used for bread and spoonmeat. The English did use *Melden* (which the natives used for a

²² Durand, *Huguenot Exile*, p. 116.

²³ *William Fitzhugh and His Chesapeake World 1676-1701*, ed. Richard Beale Davis (Chapel Hill: Univ. of North Carolina Press, 1963), p. 175.

²⁴ Nathaniel Shrigley, "A True Relation of Virginia and Maryland," in *Tracts and Other Papers*, p. 5.

salt substitute) as a pot herb; they also enjoyed boiled wild onions with sallets or baked meats. Native potatoes (Spanish potatoes, or sweet potatoes) were favored, along with the peas, beans, and natural herbs "good for broathes and sallotts."²⁵

Documentary sources give copious lists of herbs and vegetables grown in seventeenth-century Virginia but tell little or nothing about how they were cooked and used, or about what they were like. The catalog of natural and cultivated herbs includes purslane, sorrel, roses, violets, marjoram, thyme, winter and summer savory, houseleeks, rue, coriander, angelica, balm, borage, burnet, clary, columbine, tansy, wormwood, catnip, mallow, lambs quarters, hyssop, dredge, basil, rosemary, lavender, dill, caraway, cumin, anise, scurvy-grass, elecampane, comfrey, nettle, monks' rhubarb (dock), burdock, feverfew, poppies, spearmint, camomile, yarrow, mullein, sarsaparilla. Although many of those herbs had medicinal rather than culinary uses, and others served as strewing herbs on rough floors, the early Virginians apparently used herbs extensively for flavoring and for pot and sallet herbs. Some non-culinary plants had drastic effects, as a group of soldiers learned when they ate a sallet of boiled Jamestown weed (seventeenth-century Virginia's LSD) and "turn'd natural Fools upon it for several Days."²⁶

²⁵ William Strachey, "Historie of Travaile into Virginia Britannia," in *Extension of Settlement*, p. 353.

²⁶ Beverley, *History*, p. 139.

In addition to the varied peas and beans which they used both fresh and dried, and the herbs for pot and sallet, settlers grew root vegetables which they sometimes stored buried in the ground: carrots, parsnips, turnips, Spanish (sweet) potatoes, and Jerusalem artichokes. Other vegetables, except for hard-shelled pumpkins and squashes, were more limited to the summer growing season and fall harvest: cucumbers, radishes, cauliflower, *Cushaws* (crookneck squash), cabbages, colewort, lettuce, spinach, rocket, asparagus, and cress. Documentary sources indicate these vegetables were generally cooked, not eaten raw.

FRUITS

Early Virginians, especially wealthier planters, loved orchards and cultivated them with great pride and energy. Settlers with small farms or modest holdings probably had fruit trees close to their houses or near their gardens. In early Jamestown Sir Thomas Gates had apples and pears grown from seed, but later writers often mention grafting and the need for exacting care in sophisticated horticultural methods.²⁷ Governor Berkeley at Green Springs "in his new Orchard hath 15 hundred fruit-trees, besides his Apricocks, Peaches, Mellicotons, Quinces, Wardens [pears], and such like fruit"; William

²⁷ See Ralph Hamor, *A True Discourse of the Present State of Virginia* (London, 1615; rpt. Richmond: Virginia State Library, 1957), p. 37.

Fitzhugh at the end of the century had "a large Orchard of about 2500 Apple trees most grafted."²⁸

Proliferating in numerous varieties, often with short seasons, apples were roasted, stewed, or made into pies; great quantities went into summer cider, fall cider, and winter cider. In addition to small, bitter crabapples (which the English called "crabs"), apple varieties included Pearmains, Pippins, Russets, Costards, Marigolds, Codlins, Kings-apples, Magitens, Batchelours, and Cattalines.²⁹ Of the other orchard fruits, pears rivaled apples in popularity, followed by peaches, quinces, and apricots. Although figs grew well, they were seldom cultivated. Several varieties of grapes, plums (including damsons), cherries, and mulberries grew wild. Early writers give especially extensive accounts of the many grape varieties, describing attempts at establishing a wine industry and success with proper pruning of the vines. The natural grapes also went into tarts—as did most other fruits.

Early Virginians apparently prized fruit with rich sweet-tart flavors; Beverly says that one mulberry variety "does not so generally please, being of a faintish Sweet, without any Tartness."³⁰ Strawberries were especially prolific and admired, as were other berries and small fruits: raspberries, hurts (blueberries), red and black currants, and cranberries. Plentiful mulberries, according to

²⁸ Wodenoth, "Perfect Description," p. 14; *William Fitzhugh*, p. 175.

²⁹ Lawson lists still more varieties; see *New Voyage*, pp. 113-14.

³⁰ Beverley, *History*, p. 130.

Lawson, were "used instead of Raisins and Currants, and make several pretty kickshaws;" they also made good wine.³¹ Settlers similarly both infused blueberries in liquors and dried them for later use in tarts.

Early writers often remark the persimmon's astringent quality tamed only by ripeness: "The Taste of them is so very rough, it is not to be endured, till they are fully ripe, and then they are a pleasant fruit."³² Medlars, according to Harriot, were not good until rotten—then, red and "lushious sweet."³³ Unusual natural fruits included the prickly pear and *Maracock*—the fruit of the passion flower which Strachey calls a cooling summer fruit.³⁴ Also cooling were watermelons—red, yellow, or white—and large muskmelons.

Virginia's forests generously produced nuts: walnuts, hickory nuts, filberts, and chinquapins (small, burr-husked, and sweeter than the chestnuts they resembled). Acorns and groundnuts also proliferated. Although documentary sources tell a great deal about how the Indians used nuts for breads and soups, they give little indication of whether, or how, the English used nuts.

³¹ Lawson, *New Voyage*, p. 109.

³² Beverley, *History*, p. 130.

³³ Thomas Harriot, "*A briefe and true report of the new found land of Virginia*" (1588), in *Virginia Voyages from Hakluyt*, ed. David B. Quinn and Alison M. Quinn (London: Oxford Univ. Press, 1973), pp. 60-61.

³⁴ Strachey, "Historie," p. 353.

DAIRY PRODUCTS

Almost every seventeenth-century Virginia household had a cow. Estate inventories show that tenant farmers with only a few modest possessions generally had one or more cows; wealthy landowners amassed large herds. Although English yeomen apparently drank little milk, making most of it into cheese, Lord De La Warr observes as early as 1611 that milk was "a great nourishment and refreshing to our people, serving also in (occasion) as well for physicke as for Food. . . ." ³⁵

A foreign visitor later in the century notes that although Virginia's milk was excellent, her cheese was inferior, that the people did not know how to make good cheese. ³⁶ That allegation is confirmed somewhat by the orders wealthy planters placed for English cheese, especially Gloucestershire; yet planters also ordered butter from England, and one wonders how imported butter could exceed in quality even mediocre domestic butter. Both butter and cheese were sold locally, apparently by one householder to another; the frequent presence in York County estate inventories of churns, butter tubs and pots, cheese vats and presses indicates that Tidewater households engaged in serious dairying. Cheese presses suggest hard cheese, and a York County bill of sale includes "Cheshyre cheese" (a hard

³⁵ "De la Warr's Relation," in *The Genesis of the United States*, ed. Alexander Brown, Vol. I (1890; rpt. New York: Russell and Russell, 1964), pp. 481-82.

³⁶ "Journey of Francis Louis Michel," p. 36.

Cheddar-type cheese); apart from such clues, however, we have little indication of the kinds of cheeses made.

FATS AND OILS

Estate inventories and bills of sale indicate that colonists used butter, olive oil, and lard as fats. Household dairying produced butter—sometimes enough to sell. Settlers who could purchase products from England or Barbados ordered the olive oil favored for sallets of cooked vegetables; oil figures in estate inventories and planters' correspondence, and Iberian olive jars which may have originally held oil have been found at archaeological sites. Inventories occasionally mention lard, probably routinely produced in hog butchering. Despite John Lawson's enthusiasm for bear fat, we have little evidence that Virginians used fat from game, but salted beef and pork probably contributed fat to the diet in hominy or stew-type dishes.

BEVERAGES

Favoring beer and cider, seventeenth-century Virginians drank lesser amounts of milk, wine, spirits, and water. Drinking water presented serious problems; although inland dwellers often had good water from natural springs, others often had unsafe water, salty from

the river or contaminated from shallow wells. Beer and cider were safer, and documentary sources indicate Virginians often made them on a considerable scale; stillyards (frames to support brewing casks) appear in inventories almost as often as iron pots and frying pans. Although Jamestown had public brewhouses, both inventories and the chronicler Wodenoth confirm that "most brew their owne Beere, strong and good."³⁷ Malt was more likely purchased or imported than made at home; poorer people made beer with molasses and bran, malted corn, dried persimmon cakes, corn stalks, pumpkins, or even Jerusalem artichokes.³⁸

Cider, made as fruit came into season, varied considerably with variety of apple and quality of production; frequent production helped offset cider's disadvantage of quick spoilage. Settlers also made perry (pear cider). Although some distilling took place in Virginia, most strong liquors—chiefly rum and brandy—were imported and thus limited to the affluent. Wealthy planters regularly ordered sack, Madeira, claret, canary, and Rhenish wine—usually in large quantities and possibly for resale to their neighbors. Although attempts to produce wine failed commercially, individual planters sometimes made respectable wine for their own use.

Virginians apparently liked to sweeten their liquor, whether glasses of brandy or bowls of punch—that most flamboyant of all sweetened drinks, inseparable from revels of the rich. As Durand

³⁷ Wodenoth, "Perfect Description," p. 3.

³⁸ Beverley, *History*, p. 293.

describes the composition of punch, "They put in three jugs of beer, three jugs of brandy, three pounds of sugar, some nutmegs & cinnamon, mix these well together & when the sugar has melted they drink it, & while making away with the first, they prepare another bowl of it."³⁹ Michel gives a simpler punch recipe: half a vessel of cold water, sugar with vinegar and nutmeg, glasses of rum, and sometimes lemon.⁴⁰ William Byrd ordered casks of lime juice from Barbados and probably used it exclusively in punch, perhaps selling smaller quantities to neighbors.⁴¹ Although Byrd ordered some chocolate at the end of the century, that beverage was probably little used then even by the wealthy planters, and documentary evidence fails to suggest that coffee or tea made even that much of an inroad before the eighteenth century.

SWEETENERS

Sugar, molasses, and honey sweetened the food of seventeenth-century Virginia, abetted sometimes by dried and fresh fruits. Planters imported sugar and molasses in large quantities, often from Barbados, and sold smaller amounts to their neighbors. Estate inventories most often mention simply "sugar," but sometimes

³⁹ Durand, *Huguenot Exile*, p. 138.

⁴⁰ "Journey of Francis Louis Michel," p. 40.

⁴¹ *The Correspondence of the Three William Byrds of Westover, Virginia, 1684-1776*, ed. Marion Tinling (Charlottesville: Univ. Press of Virginia, 1977), I, 51, 64-65.

distinguish "white sugar" or "brown sugar." William Byrd's correspondence most often refers to sugar as *muscovado*—raw crystalline sugar from the first drainage of molasses; William Fitzhugh ordered "sun dried Sugar" and powdered sugar.⁴²

Honey was probably more generally available than infrequent inventory entries indicate, for yeomen indeed kept bees in Virginia as in England. Although appraisers sometimes list swarms of bees among an estate's possessions, prudent York County appraisers in 1662 reported, "The Bees wee conceive not to be Appraised."

In general, the use of sweeteners depended on either wealth or resourcefulness. The affluent could purchase sugar and molasses, whereas poorer but enterprising households could keep bees and thus enjoy honey. Documentary sources do not indicate that households produced "stillroom sweets"—conserves, marmalades, or sweetmeats—but the large plantations probably did so at the century's end, and wealthy Virginians probably brought or ordered those sweets from England whenever possible.

⁴² *Correspondence of the Three William Byrds*, pp. 51, 65, 75, 89, 113, 144; *William Fitzhugh*, p. 195.

CONDIMENTS AND SEASONINGS

Virginians tried throughout the century to produce salt commercially, with little or no success. Necessary for preserving meat and fish, "salt" and "bay salt" appear frequently in estate inventories, often in large quantities (bushels and barrels). Spices were also valued highly; pepper, ginger, cloves, mace, nutmeg, and cinnamon appear most frequently in inventories and shipping invoices. Natural and domestic herbs provided a variety of seeds—*anise, dill, caraway, cumin*—and their leaves also flavored foods. Settlers purchased vinegar, a favorite condiment of English yeomen, and they must have also produced it at home; a few inventories include mustard pots. For the middling and poorer settlers, flavors probably came chiefly from the assertive natural or staple foods: earthy corn and legumes, sweet-tart fruits, pungent and savory herbs, gamey wild meat, and potentially overwhelming salted seafood.

THE DIET OF SLAVES

Although tenant farmers generally enjoyed the same variety and quantity of foods as landowners, slaves (and sometimes servants) had a more restricted diet. Masters were bound by terms of indenture to feed and clothe servants, and their financial investment in slaves and need for labor evoked a commitment to the slaves' physical well-being, but expedience and self-interest frequently prompted landowners to

feed dependent laborers the most plentiful, least costly foods, especially when laborers were housed in quarters apart from the main house.

Although slaves probably caught small game in addition to the turtles mentioned by Michel, corn was the mainstay of their diet. Michel writes that whereas he was served beans cooked with bacon—a dish prepared at a Tidewater plantation for the overseer of the slaves—"The food prepared for the negroes that work was pounded Turkish maize, cooked in water, called hominy, a healthy food."⁴³ Similarly, Durand describes "an excellent but somewhat indigestible soup" made of the coarse hominy grains. "With this soup they feed the slaves, & it costs very little to maintain them, particularly the negroes, for in some places they are given bread & meat only on Christmas day."⁴⁴ Confirming these travelers' accounts, Lawson writes,

those poor Christian Servants in *Virginia, Maryland*, and the other northerly Plantations, that have been forced to live wholly upon [corn], do manifestly prove, that it is the most nourishing Grain, for a Man to subsist on, without any other Victuals. And this Assertion is made good by the *Negro-Slaves*, who, in many Places, eat nothing but this *Indian Corn* and salt.⁴⁵

⁴³ "Journey of Francis Louis Michel," p. 114.

⁴⁴ Durand, *Huguenot Exile*, p. 117.

⁴⁵ Lawson, *New Voyage*, p. 81.

Chapter 5
FACILITIES AND EQUIPMENT

Existing archaeological and documentary evidence of buildings in seventeenth-century Virginia suggests a three-phase development of cooking facilities. The earliest common-room dwellings had primitive fireplaces, most commonly of wattle-and-daub.¹ As the settlers began to manufacture bricks locally, houses could include brick fireplaces with ovens, as evident at Jamestown in dwelling sites from the second half of the century.² Then, as houses became larger and slaves became available, and as household labor moved from the main dwelling to outbuildings, cooking activities sometimes shifted to a detached building.³ Since increasing sophistication of cooking facilities coincided with increasing personal wealth, the more primitive facilities probably continued throughout the century, with a family's economic status influencing the extent and nature of its kitchen.

¹ For example, the conjectural reconstructions at Jamestown or the 1620-1630 dwellings at the Maine site, described in Alain C. Outlaw, "An Interim Report, Governor's Land Archaeological District Excavations: The 1976 Season," May 1978 (manuscript at Virginia Research Center for Archaeology, Williamsburg), pp. 41-43.

² John L. Cotter, *Archeological Excavations at Jamestown, Colonial National Historical Park and Jamestown National Historic Site, Virginia*, Archeological Research Series No. 4 (Washington: National Park Service, U. S. Department of the Interior, 1958), pp. 49, 86.

³ See the account of Durand of Dauphine, *A Huguenot Exile in Virginia*, ed. Gilbert Chinard (The Hague, 1687; rpt. New York: Press of the Pioneers, 1934), pp. 119-20. The Jamestown excavations indicate that Structure 45 there may have been a separate kitchen associated with a large house; see Cotter, *Archeological Excavations*, pp. 57, 86.

Food storage apparently followed a similar pattern. In small dwellings food was stored within the house or in adjacent lean-tos and sheds. Cellars also served for storage, and some houses had butterys or cool rooms especially for food storage.⁴ A puzzling well-type site at Jamestown may have been an ice storage pit, and a brick-lined recess in the center of a Jamestown cellar may have been used for wine storage.⁵ Wells were sometimes used for cooling foods or for storage of milk. York County inventories list milk houses, but in general we have little evidence of outbuildings for specialized activities relating to food. Outbuildings were more generally for food storage than food preparation; supplies of dried grain, legumes, and salted meat required considerable space.

Seventeen York County probate inventories from the second half of the century mention a kitchen as a specific room within the house—or possibly in some cases as a separate building. Four York inventories mention a milk house, and three mention a buttery. Only two inventories in the Surry County records mention a kitchen, and none refers to other food-related rooms or structures. Only wealthy estates had kitchens or specialized outbuildings, so those structures

⁴ York County inventories mention butterys. Archaeological evidence of a buttery at Pettus Plantation is described by William Kelso in "An Interim Report on the Excavation at Kingsmill Plantation: The 1973 Season," March 1974 (manuscript at Virginia Research Center for Archaeology, Williamsburg), p. 3.

⁵ Cotter, *Archeological Excavations*, pp. 140-41, 147-49. An ice pit was also found at the Denbigh plantation site in Warwick County; see Audrey Noel Hume, *Food*, Colonial Williamsburg Archaeological Series No. 9 (Williamsburg: Colonial Williamsburg Foundation, 1978), p. 10.

were clearly uncommon for the general population. Large, cumbersome, and messy activities such as salting meat, making cheese, or brewing probably took place outdoors. The following tables (4, 5, and 6) show the frequency with which cooking vessels, utensils, and equipment are mentioned in the York and Surry inventories. The next section of this chapter discusses the implications of these possessions and compares findings from the inventories with archaeological artifacts and paintings.

Table 4. Mention in Estate Inventories of Cooking Vessels, Utensils, and Equipment, York County Court Records, 1638-1699

	1630- 1639*	1640- 1649	1650- 1659	1660- 1669	1670- 1679	1680- 1689	1690- 1699
	N=1	N=8	N=19	N=27	N=33	N=44	N=54
VESSELS							
Pot	1	7	10	26	28	41	44
Kettle	1	4	8	22	20	35	30
Frying pan		6	12	23	17	34	39
Skillet		6	4	16	17	23	28
Skillet frame				1		2	3
Posnet				1	3	2	1
Sauce pan				4	4	4	7
Stew pan				1	2	2	3
Earthen pot				4	6	8	3
Pie pan/plate				4	2	1	1
Pudding pan				5	1		2
Tin/brass pan			1	4	2	5	7
UTENSILS							
Flesh fork		1	2	5	5	11	18
Ladle			5	10	8	10	14
Skimmer			5	11	10	8	22
Peel					1	1	1
Slice				1	1		5
Toasting iron/fork					1	1	2
EQUIPMENT							
Andirons		2	4	11	10	7	16
[Fire] dogs			2	3	3	6	8
Pot hook(s)		5	7	21	15	33	36
Pot hangers		1		1	2	1	1
Pot rack(s)		1	3	15	17	18	26
Rack(s)			1	1	1	1	4
Spit rack			1	1	3	2	1
Spit		1	8	21	17	25	33
Dripping pan		2	5	16	13	14	21
Jack				4	4	5	2
Clock			3	1	2	1	1
Trivet				1	1		6
Gridiron		1	3	9	7	10	21

*The single inventory for this decade is dated 1638.

Table 5. Mention in Estate Inventories of Cooking Vessels, Utensils, and Equipment, Surry County Court Records, 1663-1699

	1663- 1669 N=4	1670- 1679 N=32	1680- 1689 N=32	1690- 1699 N=36
VESSELS				
Pot	3	26	28	34
Kettle	1	16	17	21
Frying pan	3	25	23	11
Skillet	2	15	13	11
Posnet		2	2	2
Sauce pan		4	1	
Stew pan		1	2	
Earthen pot			3	1
Tin/brass pan		5	4	1
Copper		3		
UTENSILS				
Flesh fork		9	14	10
Ladle		13	11	5
Skimmer	1	11	7	6
Slice		2	1	1
EQUIPMENT				
Andirons	1	6	4	8
[Fire] dogs		3	2	4
Pot hook(s)	2	11	15	21
Pot hangers		2	2	
Pot rack(s)	1	15	15	21
Rack(s)		1		2
Spit	2	14	20	21
Dripping pan	1	8	8	10
Gridiron		7	5	5

Table 6. Cooking Vessels, Utensils, and Equipment Infrequently Mentioned in Estate Inventories from County Court Records

York County
(1638-1699)

Earthen pipkin
Biscuit pan
Patty pan
Roaster
Apple roaster
Custard pan/cup
Tin baster
Tin egg spoon
Pie peel
Turnpike spit

Surry County
(1663-1699)

Porridge pot
Pipkin
Pie pan/plate
Pudding pan
Apple roaster
Custard pan
Toaster
Toasting iron
Pie peel
Trivet
Jack
Clock

THE FIREPLACE AND ITS EQUIPAGE

The fireplace served as the all-purpose cooking center for seventeenth-century Virginians. Sometimes as wide as eight or nine feet and as deep as three and a half feet, with varied and specialized equipment for controlling the degree and kind of heat to which food was subjected, the fireplace and its sometimes adjacent oven provided for boiling, stewing, roasting, broiling, frying, and baking. Vessels and utensils with varied shapes and designs also allowed a range of possibilities: sizes accommodated volumes from tiny to huge; handles gave maneuverability; feet raised pots above embers; shallow flat pans or grids allowed intense heat for quick cooking.

Basic equipment included andirons, fire dogs, spits, pot hooks, hangers, and racks. Andirons raised logs above the fireplace floor—as they do today—and their front supports sometimes included racks for holding meat spits close to the fire. Although often defined as synonymous, andirons and fire dogs apparently were not the same; some inventories list both. Lindsay suggests that andirons were the larger, more important fire dogs and were more likely to include a spit rack;⁶ "large rack andirons" appear occasionally in inventories. Sometimes the spit rack was separate from andirons or dogs (see Plate 2), and spits were simply slender iron rods which could be thrust through large pieces of meat or whole fowl. Under them were placed

⁶ J. Seymour Lindsay, *Iron and Brass Implements of the English House* (London: Alec Tiranti, 1964), p. 9.



Plate 2. Spit rack from Bennett Farms site in York County. Length 94.5 cm; archaeological context post-1677. Photo courtesy of Virginia Research Center for Archaeology; YO68/24A.

dripping pans, large shallow iron or tin vessels that caught drippings from the roasting meat. Plate 3 shows in a seventeenth-century Dutch painting a dripping pan, a spit rack similar to the artifact in Plate 2, and a spit equipped with a handle for turning. Spits were sometimes rotated with a jack, the jack sometimes powered by a clockwork mechanism. Although jacks and clocks appear infrequently in the York and Surry inventories, andirons, dogs, spits, and dripping pans are among the most frequently mentioned items, indicating that spit-cooking was both common and important in seventeenth-century Virginia.

Pots, kettles, frying pans, and skillets are the most frequently mentioned cooking vessels. Most often of iron, the pots had two ears—or handles—at the sides, three feet, and usually a rounded shape (see Plate 4 and Figure 4). Kettles, frequently of brass but also of copper or iron, were large cooking pots, greater in width than depth, usually with a handle (or hooks for a handle) and no feet.⁸ Kettles do not figure in archaeological artifact assemblages as do iron pots, because brass and copper did not break as easily as iron and could be repaired with tinker's dams—riveted patches ubiquitous among artifact assemblages. Figure 5 shows a kettle described by Randle Holme:

⁸ Proving that nothing is consistent but inconsistency, a three-legged kettle stands brazenly in "The Courtyard of a House in Delft" (1658), by Pieter de Hoogh. See J. M. Nash, *The age of Rembrandt and Vermeer*, 2nd ed. (Oxford: Phaidon, 1979), plate 122.



Plate 3. Detail from "The Netherlandish Proverbs" (1559), by Pieter Bruegel, showing a spit rack similar to the artifact in Plate 2. The dripping pan resembles one in Randle Holme's *The Academy of Armory* (illustration 34 facing p. 18).⁷ A skimmer stands at the left. The painting is illustrated in Timothy Foote and the Editors of Time-Life Books, *The World of Bruegel c. 1525-1569* (New York: Time-Life Books, 1968), pp. 152-53, 156.

⁷ Descriptions and illustrations attributed in this chapter to Randle Holme are from the 1905 edition of *The Academy of Armory*, Book III, Chapter 14.



Plate 4. Fragment of iron pot from Pettus site in James City County; archaeological context 1690-1710. Photo courtesy of Virginia Research Center for Archaeology; KM 64AB.



Figure 4. Pot drawn from Randle Holme (illustration 38 facing p. 18). Holme identifies the vessel as "a Flesh pott, or a Brasse pott, or a pott to boile in" (p. 8).



Figure 5. Hanging kettle drawn from Randle Holme (illustration 90 facing p. 18).

There are some which call it a hanging Kettle, from the Iron hookes it hangs by: the french call it a caldron, but in our countrey these kind of round bellyed pans, or if they be flatt bottomed, haveing such a handle fastned to it, to rise and fall upon the rime of the pann is called a Kettle be it bigg, or a little Kettle. If it have no handle or hoope to hang it by, it is no other than a pan. (p. 17)

A kettle illustrated in a painting is shown in Plate 5. Descriptions in inventories indicate that kettles were generally larger than pots, sometimes weighing over sixty pounds and holding volumes as large as twenty and twenty-six gallons. Coppers were large open vessels for cooking or laundry, more likely for use outdoors than in fireplaces.

A variety of pot hooks, racks, and hangers suspended pots and kettles over the fire. Plate 6 shows a collection of hooks found at Jamestown; the hinged hook on the left is similar to one illustrated by Randle Holme (Figure 6). Figure 7 shows a similar hinged pot hook, along with an S-shaped pot hook representing yet another type; the S-hook could have hooked to the center of the hinged hook. Among the Jamestown artifacts is an iron trammel, or pot rack, which corresponds to the trammel portion of a rack illustrated by Randle Holme and shown in Figure 8.⁹ Inventories list both pot racks and pot hangers; the apparent distinction is that racks are vertical, usually with a series of hooks at varying heights or with a trammel, while hangers are horizontal. This distinction presents problems, however, for sources give vague and similar definitions. For an

⁹ The Jamestown trammel is illustrated in Cotter, *Archeological Excavations*, p. 173.

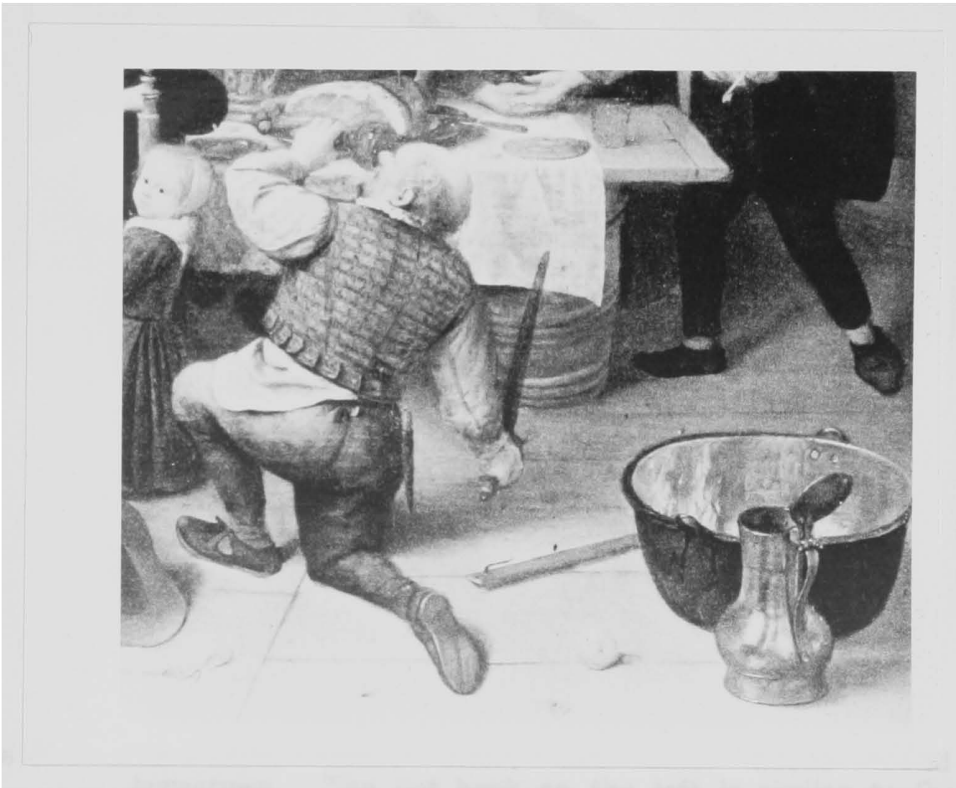

Plate 5. Detail from "The Prince's Birthday" (c. 1660), by Jan Steen, showing a kettle which resembles the one in Figure 5; in front of the kettle is a jug. The painting is illustrated in B. Haak, *Art Treasures of the Rijksmuseum, Amsterdam* (New York: Harry N. Abrams, 1966), plate 66.

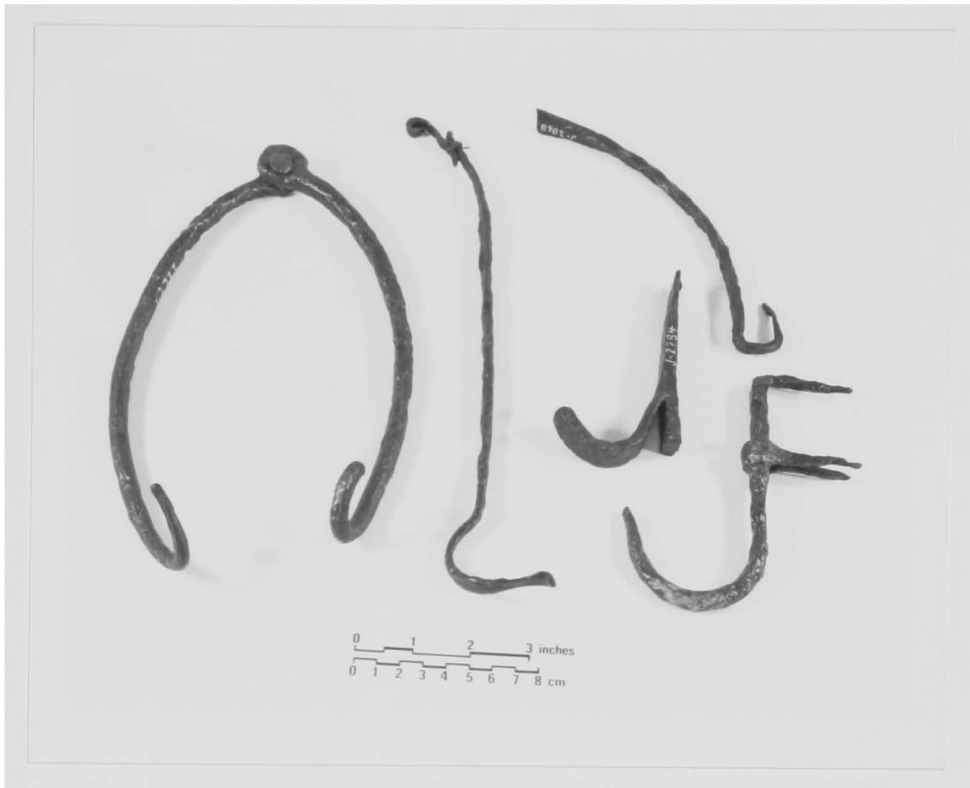

Plate 6. Pot hook, kettle tilter, and other hooks found at Jamestown. The pot hook on the left is similar to Randle Holme's illustration in Figure 6; the open hooks on the ends fastened to hooks or ears on the side of a pot or kettle, and the hinged center attached to another hook which suspended the pot over the fire. The long implement to the right of the pot hook is probably a kettle tilter for pouring from a kettle without removing it from the fire (see Lindsay, *Iron and Brass Implements*, p. 13). Artifacts photographed courtesy of National Colonial Historical Park, National Park Service, Jamestown; J-2733, J-702, J-2068, J-19441, and J-2284.



Figure 6. Pot hook described by Randle Holme as "A paire of hanging pot hookes . . . of course must come after the flesh pott haveing a dependency upon it, and without it the pott cannot well be set over the fire, for two hookes holds the pott b[y] the eares, and the top hooke, put in a Link of a Chaine, hung over crosse the chimney above the mantle-tree: so that it is thereby set higher, or lett downe lower, as occasion is." Drawn from illustration 39 facing p. 18.



Figure 7. Pot hooks found in James City County. The S-shaped hook is from a post-1635 archaeological context at Kingsmill Tenement (KM 425A); the hinged hook is from a 1618-1625 archaeological context at the Maine site (GL 101C). Artifacts, Virginia Research Center for Archaeology.

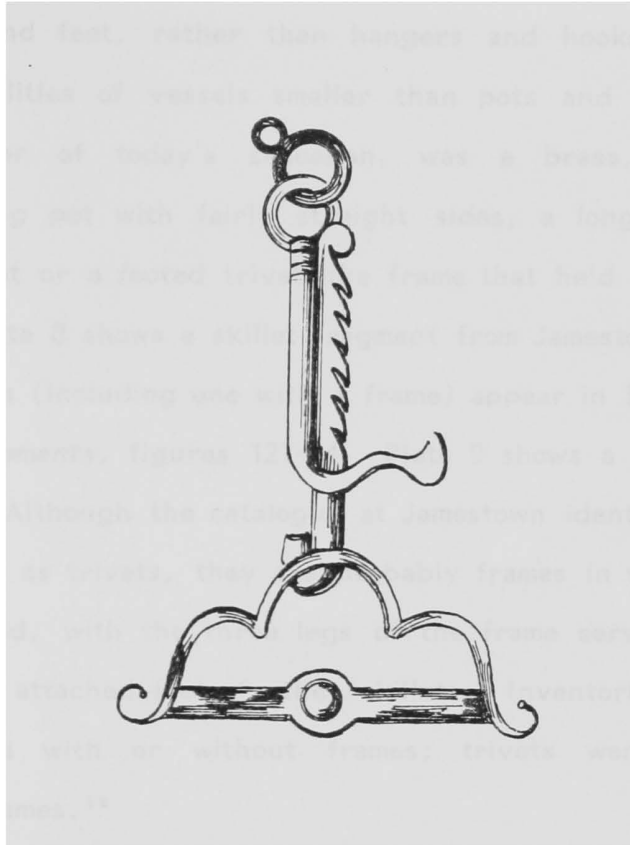

Figure 8. A pot rack with hanger, described by Randle Holme as "a pott rack, with an hanging Branrett thereat . . . is a cuntry way of hanging potts, and pans over the fire, where by the lowering, or putting up of the rack, the pott or pan is the same from the heate of the fire" (p. 9). Drawn from illustration 40 facing p. 18.

illustration of an elaborate pot-hanging apparatus which combines hangers, racks, trammels, and hooks, see Plate 7.

Handles and feet, rather than hangers and hooks, varied the cooking possibilities of vessels smaller than pots and kettles. The skillet, ancestor of today's saucepan, was a brass, copper, or bellmetal cooking pot with fairly straight sides, a long handle, and either short feet or a footed trivet-like frame that held it above coals or embers. Plate 8 shows a skillet fragment from Jamestown; examples of whole skillets (including one with a frame) appear in Lindsay's *Iron and Brass Implements*, figures 121-24. Plate 9 shows a fragment of a skillet frame. Although the catalogue at Jamestown identifies this and similar artifacts as trivets, they are probably frames in which footless saucepans rested, with the three legs of the frame serving the same purpose as the attached feet of other skillets. Inventories frequently mention skillets with or without frames; trivets were apparently heavier than frames.¹⁰

Usually defined as synonymous with the skillet, a posnet is also a metal cooking pot with a long handle and three short feet (see Figure 9). The posnet, however, is generally smaller than a skillet, more likely rounded than straight-sided, and never used with a frame. As Randle Holme describes the posnet, "This vessell or Instrument for boileing, is the same in bodily shape, to the flesh pott . . . save that

¹⁰ Shipping invoices also mention skillets and skillet frames. See Neville Williams, "The Tribulations of John Bland, Merchant: London, Seville, Jamestown, Tangier, 1643-1680," *Virginia Magazine of History and Biography*, 72 (Jan. 1964), 19-41.

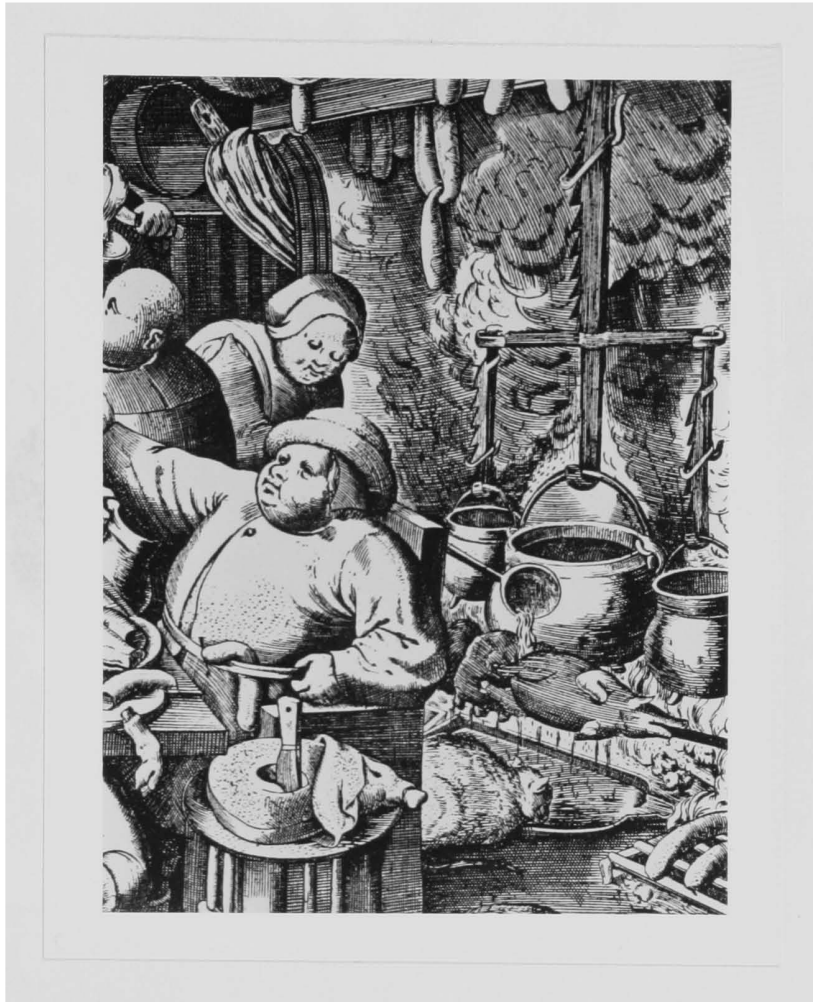

Plate 7. Detail of "The Rich Kitchen" (1563), by Pieter Bruegel, showing an apparatus of trammels, racks, hangers, and hooks suspending cooking pots. Note also the spit and dripping pan in front of the pots. From H. Arthur Klein, *Graphic Worlds of Peter Bruegel the Elder* (New York: Dover, 1963), plate 36.



Plate 8. Fragments of a skillet and of a pot found at Jamestown. Photographed courtesy of National Colonial Historical Park, National Park Service, Jamestown; J-8827 and J-9249.

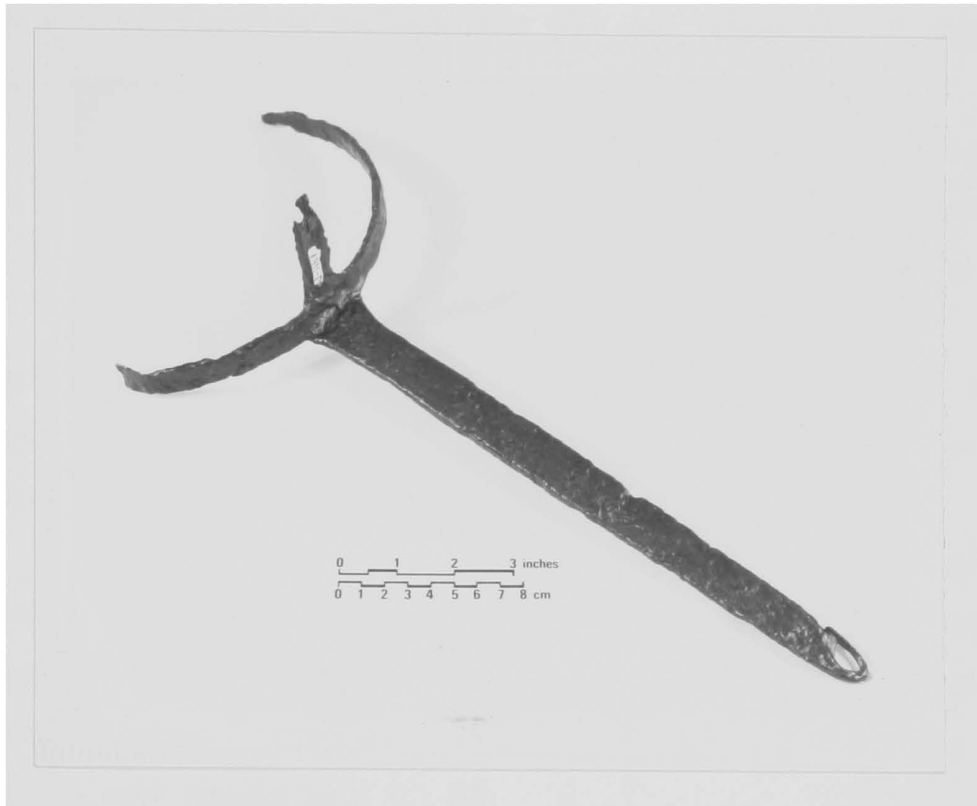

Plate 9. Iron skillet frame found at Jamestown. Photographed courtesy of National Colonial Historical Park, National Park Service, Jamestown; J-1161.

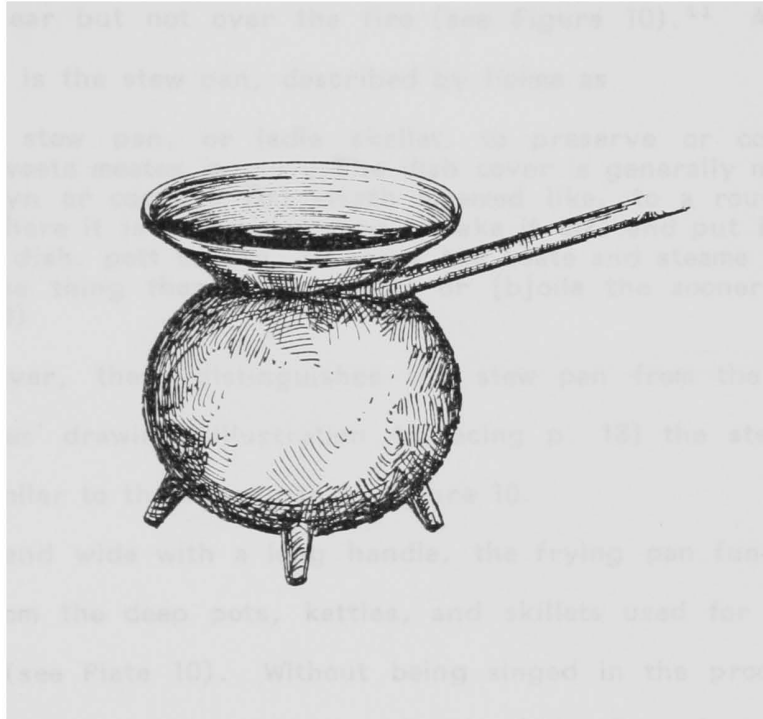

Figure 9. A posnet drawn from Randle Holme (illustration 94 facing p. 18).

in place of the two eares, it hath a long handle, to set it one, and take it of the fire" (p. 18).

A sauce pan was a small skillet with a long handle and no feet, for boiling sauces or other small amounts of food; it probably rested on a trivet near but not over the fire (see Figure 10).¹¹ Another "ladle skellet" is the stew pan, described by Holme as

a stew pan, or ladle skellet, to preserve or conserve sweete meates in . . . The dish cover is generally made of Tyn or copper, [it] riseth piramed like, to a round top where it is fastened a ring to take it off, and put it upon a dish, pott or pan, to keepe the heate and steame in that the thing therein may heate or [b]oile the sooner. (p. 10)

Perhaps a cover, then, distinguishes the stew pan from the sauce pan; in Holmes' drawing (illustration 46 facing p. 18) the stew pan looks very similar to the sauce pan in Figure 10.

Shallow and wide with a long handle, the frying pan functioned differently from the deep pots, kettles, and skillets used for boiling and stewing (see Plate 10). Without being singed in the process, a cook could easily move the pan in and out of the fire, frying food quickly over intense heat.

Small metal utensils for fireplace cooking enabled cooks to move food and liquids either in and out of pans or in and out of the fire. The flesh fork was simply a two-pronged fork for removing meat from a pot; a toasting fork was more likely a three-pronged implement, lighter and perhaps with a long wooden handle, for toasting bread or

¹¹ A small metal saucepan not much larger than a ladle is on exhibit at the National Colonial Historical Park at Jamestown.

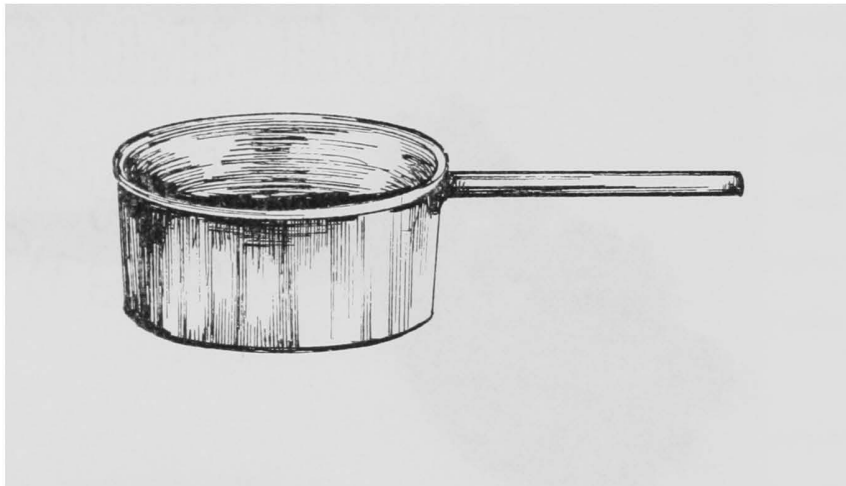

Figure 10. A sauce pan described by Randle Holme as "a Ladle skellet, a skillet with an handle, or a sawce pan . . . Some terme it a pan or posnet" (p. 3). Drawn from illustration 11 facing p. 18.



Plate 10. Frying pan handle from the Maine site in James City County (GL 1058), and frying pan fragment from the Petitt site in James City County (GL 4A). Photograph courtesy of Virginia Research Center for Archaeology.

meat (see Plate 11). For examples of seventeenth-century flesh forks and toasting forks from museum collections, see Lindsay, *Iron and Brass Implements*, figures 173-79.

Ladles were used both for removing liquids and stews from pots and for basting meat on a spit (see Plate 12). Ladles and dippers were also used in dairy operations and for serving food, but the iron ladles mentioned in inventories are most likely for fireplace use. Perforated to allow draining of liquid, skimmers also served both dairying and cooking purposes, and inventories make no distinction of the kind or size of skimmers listed. In general the flat skimmers with long handles were for cooking, for removing scum (skimming) as well as for removing food from pots. Smaller skimmers with short handles were used in dairying to remove cream from the top of milk (see Plates 13 and 14, as well as Plate 3).

The slice is similar to a skimmer, allowing liquid or fat to drain from food; with a flat perforated paddle attached to a long handle, it functions more like today's pancake turner. Randle Holme gives this description:

There is an other little Instrument of this nature used by cookes called an egge spoon or slice, it is made much after the same maner [as a skimmer], but more ovall; yet some are round at the handle and square at the other ovall end. With this they turne anything that is either fried in the ffrying pan; or stewed in a stew pan: as eggs, fish, flesh, or fritters.

An example of a slice in a museum collection appears in Lindsay's *Iron and Brass Implements*, figure 167. Also with a flat paddle and long

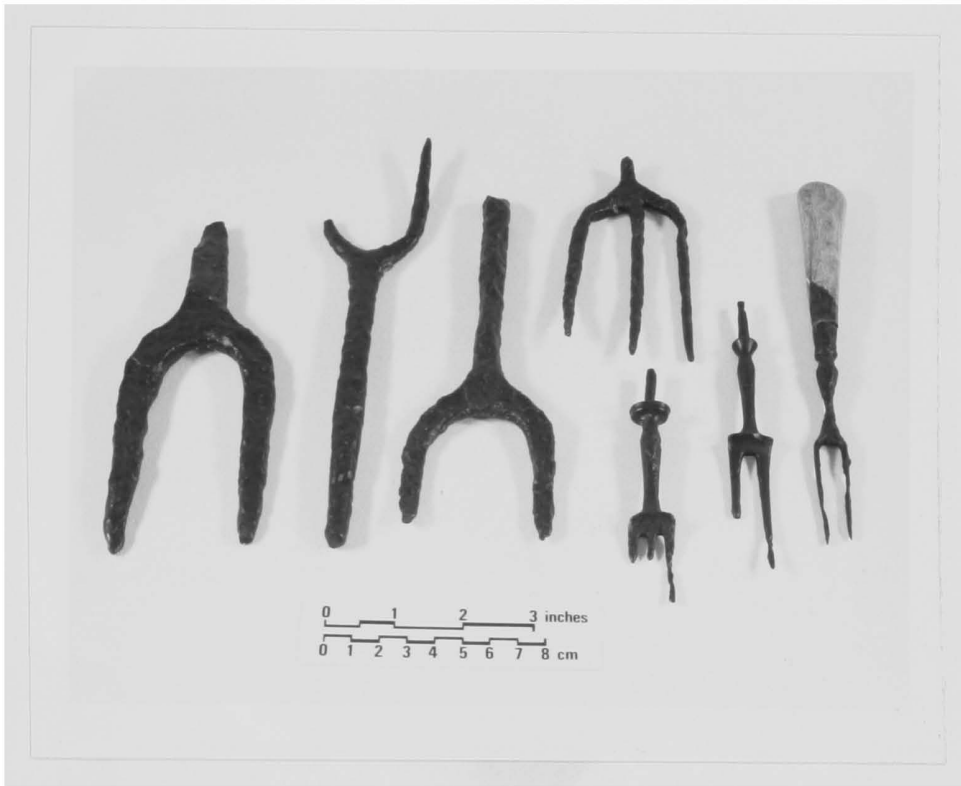

Plate 11. Forks found at Jamestown. The three on the left are fragments of flesh forks. The three-pronged fork at the top is probably a toasting fork; the others are dining forks. Photographed courtesy of National Colonial Historical Park, National Park Service, Jamestown; J-279, J-235, J-233, J-172, J-1353, J-12066, J-500.



Plate 12. Iron ladle found at Jamestown. Photographed courtesy of National Colonial Historical Park, National Park Service, Jamestown; J-1044.

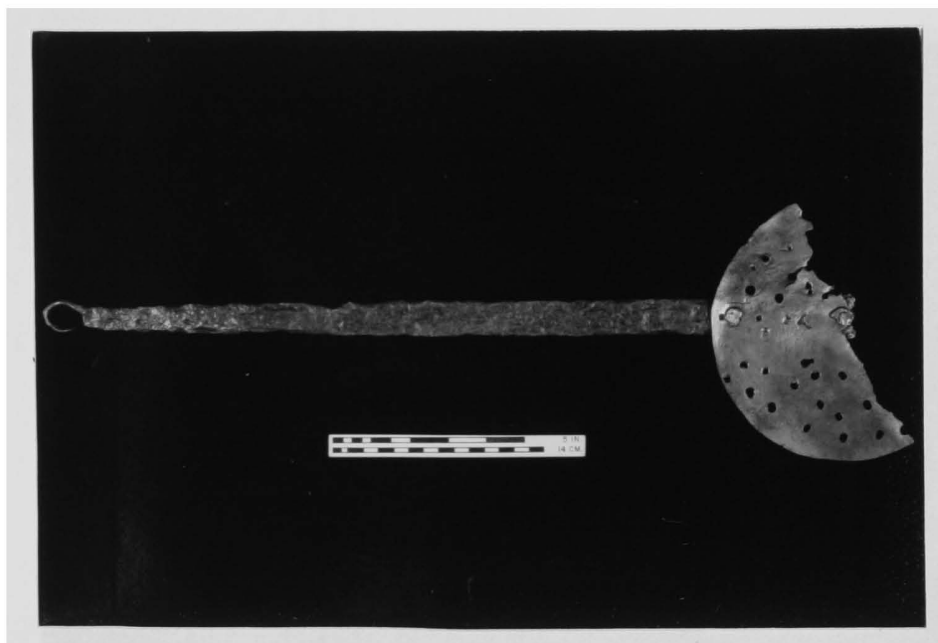

Plate 13. Brass skimmer with iron handle found at the Petitt site in James City County, in an archaeological context of 1690-1710. Photograph courtesy of Virginia Research Center for Archaeology; GL 3A.

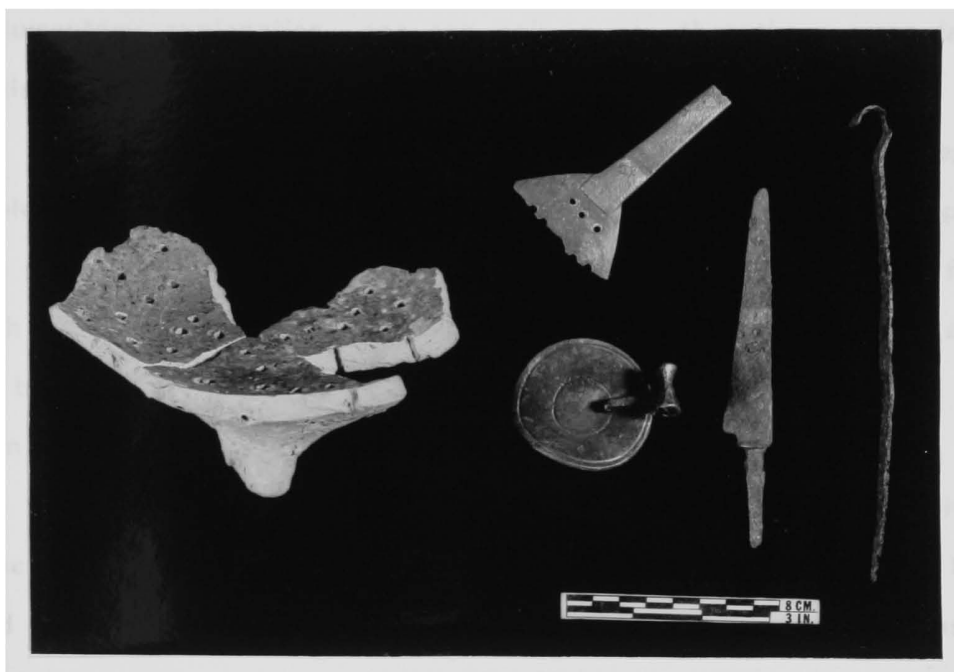

Plate 14. Collection of seventeenth-century artifacts found in James City County. At the top of the picture is a portion of a small skimmer probably used for cream (JC 8, archaeological context 1690-1710). Other artifacts are, from the left, a coarse earthenware collander (KM 394A, archaeological context 3rd qtr. C17), a pewter measure lid (ER 3A, artifact date c. 1690), an iron knife blade (L/B 11A, archaeological context 1690-1710), and a skewer (GL 105C, archaeological context 1618-1625). Photograph courtesy of Virginia Research Center for Archaeology.

handle, the heavier peel served as a "shovel" for placing bread or other food in an oven and then removing the baked product. Often called a baker's peel and sometimes made of wood, this implement almost always appears in medieval pictures of bakers at work.¹² Virginia inventories also mention pie peels; in the absence of documentary explanation, one can only guess that these were larger peels for maneuvering either pies in pie pans or pan-less pasties.

Gridirons and trivets complete the roster of important fireplace implements frequently mentioned in inventories. As its name implies, the gridiron is an iron grid formed usually of parallel bars in a frame with short legs and usually a long handle, used for supporting a pot or broiling fish or meat over a fire (see Figure 11 and Plate 15). Iron tripods or stands with three or four feet, trivets held pans near the fire for warming or over the fire for cooking. As Randle Holme describes trivets, "These kinde of Instruments are made all of Iron, and are used to be set over great fires, for Large potts, or pans, or Caldrons, to be set upon, to boile things in. They are also called Brandretts Brand Irons, Iron crowes, with three feet" (p. 7). Figure 12 shows three trivets drawn from Holme.

Except for apple roasters, few specialized or unusual cooking utensils figure in Virginia inventories, suggesting either that few settlers were able to afford or procure them, or that perhaps few

¹² See, for example, Plate 111 in *The Hours of Catherine of Cleves* (c. 1440), ed. John Plummer (New York: George Braziller, 1966).

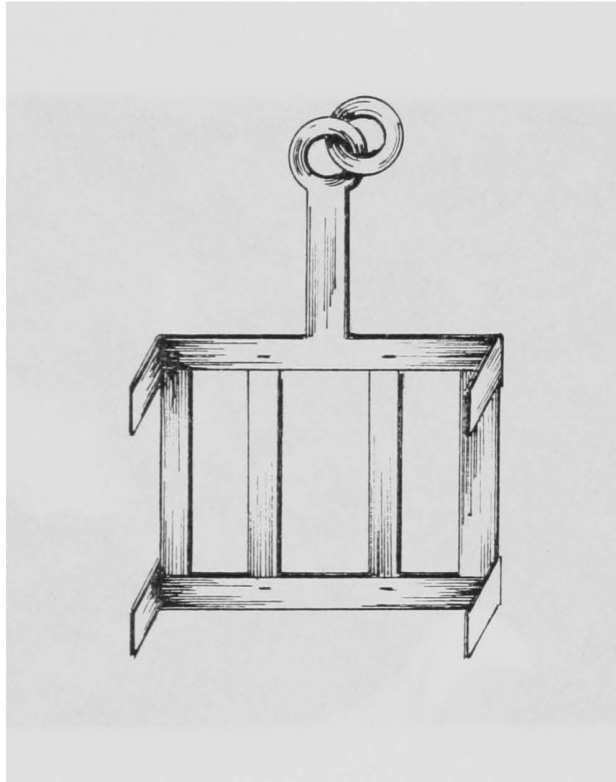

Figure 11. Gridiron drawn from Randle Holme (illustration 41 facing p. 18).



Plate 15. In this detail from "The Netherlandish Proverbs" (1559), by Pieter Bruegel, a man is broiling fish on a gridiron. Painting illustrated in Foote, *The World of Bruegel*, pp. 152-54.

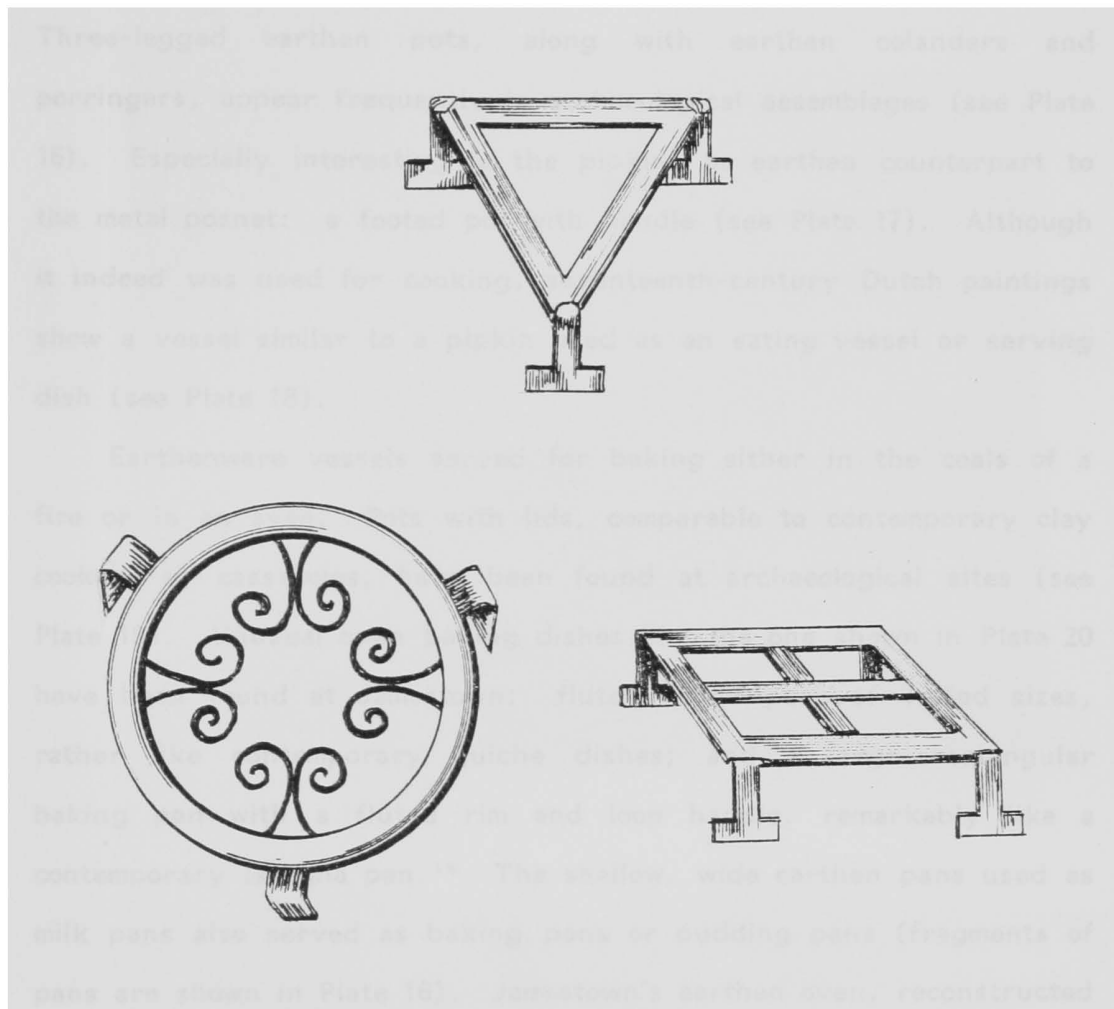

Figure 12. Three trivets drawn from Randle Holme (illustrations 30, 31, and 33, facing p. 18).

settlers had the time or interest to acquire sophisticated cooking equipment.¹³

Early Virginians typically duplicated—or approximated—in earthenware what they could neither afford nor procure in metal. Three-legged earthen pots, along with earthen colanders and porringers, appear frequently in archaeological assemblages (see Plate 16). Especially interesting is the pipkin, or earthen counterpart to the metal posnet: a footed pot with handle (see Plate 17). Although it indeed was used for cooking, seventeenth-century Dutch paintings show a vessel similar to a pipkin used as an eating vessel or serving dish (see Plate 18).

Earthenware vessels served for baking either in the coals of a fire or in an oven. Pots with lids, comparable to contemporary clay cookers or casseroles, have been found at archaeological sites (see Plate 19). Unusual open baking dishes like the one shown in Plate 20 have been found at Jamestown: fluted round pans of varied sizes, rather like contemporary quiche dishes; and a large rectangular baking pan with a fluted rim and loop handle, remarkably like a contemporary lasagna pan.¹⁴ The shallow, wide earthen pans used as milk pans also served as baking pans or pudding pans (fragments of pans are shown in Plate 16). Jamestown's earthen oven, reconstructed

¹³ Peter C. D. Brears, *The English Country Pottery* (Newton Abbot, Devon: David and Charles, 1971), pp. 247-48, defines the apple roaster as a Dutch oven made from half a large pan, with a narrow shelf; food was placed on the shelf and the oven placed with its open side close to an open fire.

¹⁴ See Cotter, *Archeological Excavations*, p. 180.



Plate 16. Locally made ceramics found at the Utopia site in James City County. In the center is a tri-leg pot and rim; at the left, a storage jar; and to the right, two pans. Photo courtesy of Virginia Research Center for Archaeology.



Plate 17. Earthen pipkin of English gravel tempered ware, found at Jamestown; diameter 16 cm. Photographed courtesy of National Colonial Historical Park, National Park Service, Jamestown; J-7475.

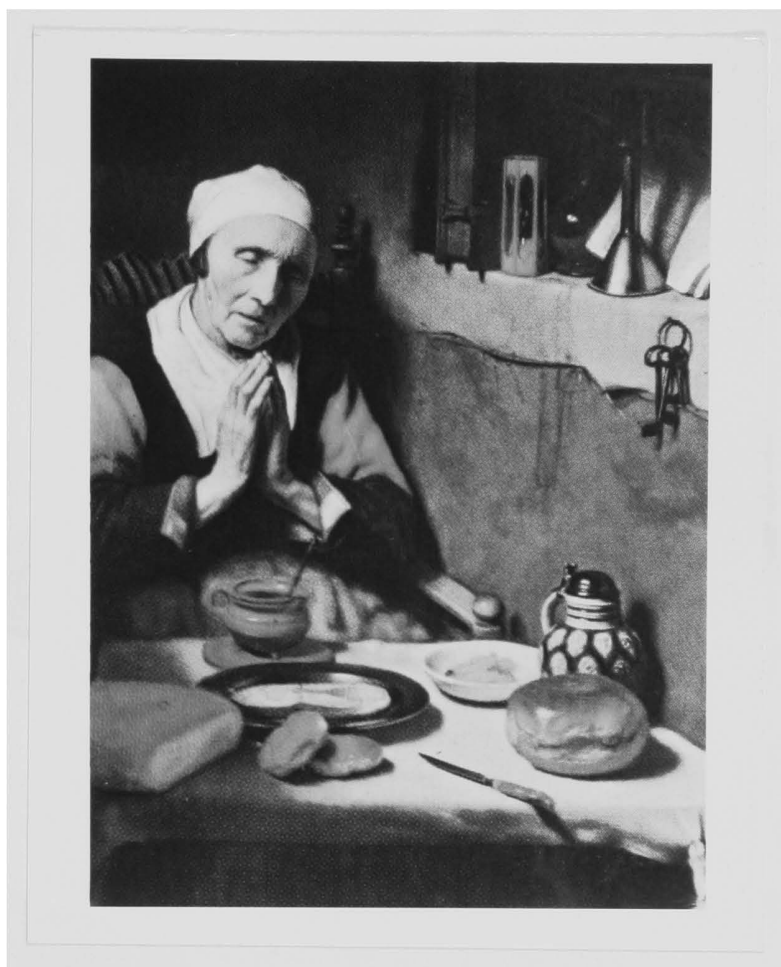

Plate 18. "An Old Woman Saying Grace" (c. 1655), by Nicolaes Maes. Before the woman is a footed loop-handled earthen pot similar to the straight-handled pipkin found in Virginia; Gabriel Metsu shows the same pot as an eating vessel in "The Sick Child" (c. 1660). To the right of the woman in Maes' painting is a jug, and on the shelf above is a funnel. Paintings illustrated in Haak, *Art Treasures*, plates 58 and 75.



Plate 19. Earthenware pot and lid found at Jamestown. Made in North Devon, England; pot diameter 27.5 cm. Photographed courtesy of National Colonial Historical Park, National Park Service, Jamestown; J-7484, J-7485.



Plate 20. Fluted earthenware pan found at Jamestown; diameter 22 cm. Photographed courtesy of National Colonial Historical Park, National Park Service, Jamestown; J-7737.

of fragments found there, both accomodated vessels and was itself a vessel (see Figure 13). Most likely used outdoors, it could be heated with a fire or hot stones placed inside, or it could be heated in the embers of a fire. Then it functioned like a brick oven. Bread or pies could be slid directy onto the heated interior with a peel, or food in pans or vessels could be placed in the oven. Of English origin, the Jamestown oven represents a type commonly used in England through the nineteenth century.¹⁵

PREPARATION AND PROCESSING

Although vessels and equipment for food preparation and processing figure frequently in estate inventories, few appear among archaeological artifacts. Cooking vessels and equipment must withstand fire and heat; thus they were made of metal and survived as artifacts. Much dairy, grain-milling, and brewing paraphernalia, on the other hand, was made of short-lived wood. Terminology also presents problems in the preparation-processing category. For example, inventories list trays, bread trays, sifting trays, milk trays, and milk pans. Trays are shallow open vessels, generally of wood; pans are also shallow open vessels, but generally of earthenware or

¹⁵ C. Malcolm Watkins, "North Devon Pottery and its Export to America in the 17th Century," *United States National Museum Bulletin* 225, Contributions from the Museum of History and Technology, Paper 13 (Washington: Smithsonian Institution, 1960), 17-59; Worth Bailey, "A Jamestown Baking Oven of the Seventeenth Century," *William and Mary Quarterly*, 2d Ser., 17 (Oct. 1937), 496-500.

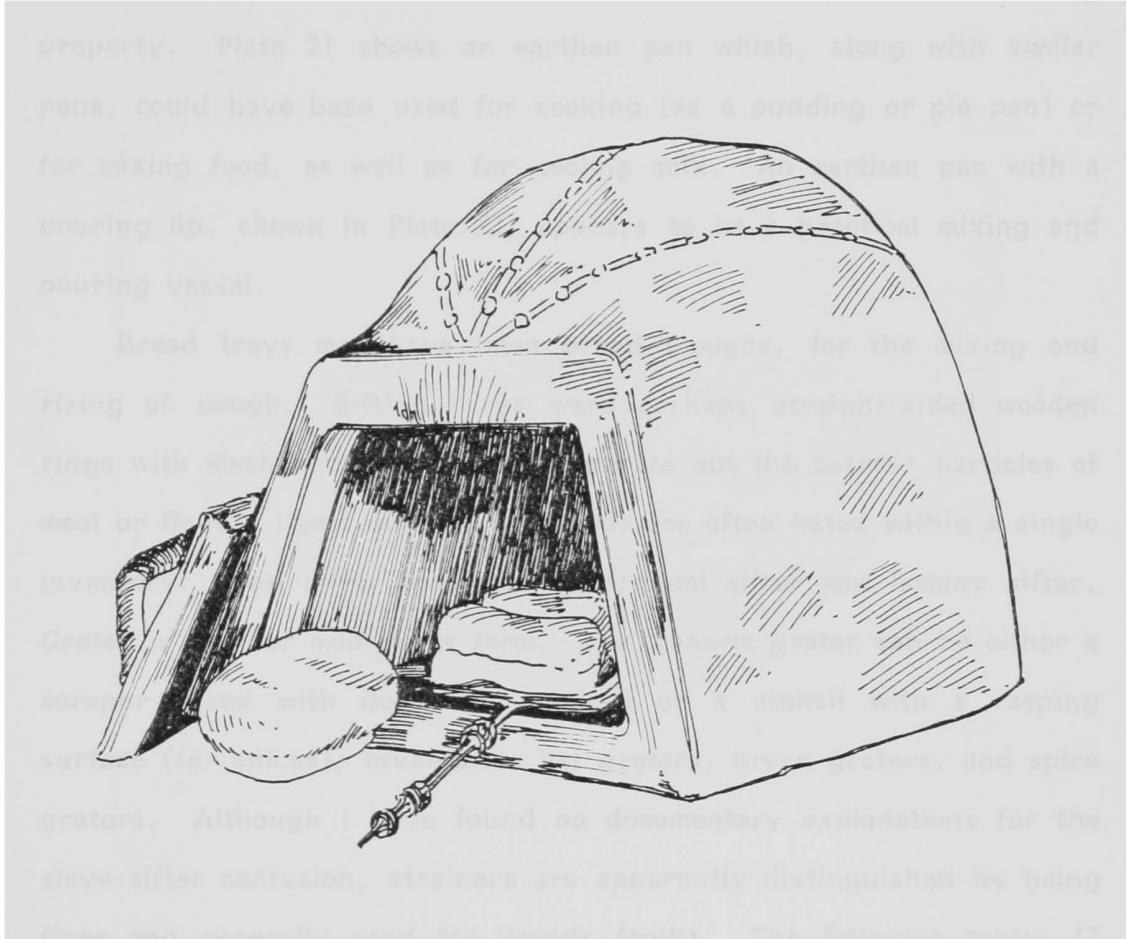

Figure 13. North Devon gravel tempered earthen oven reconstructed from fragments found at Jamestown. Artifact date 1660-1690. 60 cm high, 87 cm long, 67 cm wide; cover 23 cm high, 37 cm wide at base, 26 cm wide at top. Jamestown artifact J-7777. Drawn from Cotter, *Archeological Excavations*, plate 38, p. 74.

metal. Milk trays, then, are apparently wooden vessels for cooling milk, while milk pans are earthen vessels for the same purpose—metal serves poorly for milk pans because it lacks earthenware's cooling property. Plate 21 shows an earthen pan which, along with similar pans, could have been used for cooking (as a pudding or pie pan) or for mixing food, as well as for cooling milk. An earthen pan with a pouring lip, shown in Plate 22, appears to be a practical mixing and pouring vessel.

Bread trays may have been bread troughs, for the mixing and rising of dough. Sifting trays were perhaps straight-sided wooden rings with mesh bottoms, used to separate out the coarser particles of meal or flour. Items with similar names are often listed within a single inventory: meal sifter and meal sieve; meal sifter and hominy sifter. *Grater* is another ambiguous term. The generic grater can be either a scraper (used with dough or pastry) or a utensil with a rasping surface (for spices); inventories list graters, bread graters, and spice graters. Although I have found no documentary explanations for the sieve-sifter confusion, strainers are apparently distinguished by being finer and generally used for liquids (milk). The following tables (7 through 12) present the often mysterious inventory data pertaining to vessels and equipment used in food preparation and processing.



Plate 21. Earthen milk pan found at Jamestown; diameter 38 cm. Photographed courtesy of National Colonial Historical Park, National Park Service, Jamestown; J-11808.



Plate 22. Coarse earthen pan with pouring lip, found at the Pasbehay site in James City County. Photograph courtesy of Virginia Research Center for Archaeology, Williamsburg; GL 114A.

Table 7. Mention in Estate Inventories of Vessels Used in Food Preparation and Processing (Not in Cooking), York County Court Records, 1638-1699

	1630- 1639*	1640- 1649	1650- 1659	1660- 1669	1670- 1679	1680- 1689	1690- 1699
	N=1	N=8	N=19	N=27	N=33	N=44	N=54
Milk tray/pan			6	19	4	8	16
Tray			8	9	16	22	19
Skimming dish						1	2
Churn			1	8	2	14	12
Butter tub			1	2	1	6	5
Cheese vat			1	9	1	7	2
Bread tray				2		5	2
Tub		2	3	9	4	13	15
Powdering tub		3	3	6	4	9	4
Cooler				2			3
Pail		2	7	18	13	27	23
Piggin		1	1	5	4	10	7

*The single inventory for this decade is dated 1638.

Table 8. Mention in Estate Inventories of Vessels Used in Food Preparation and Processing (Not in Cooking), Surry County Court Records, 1663-1699

	1663- 1669 N=4	1670- 1679 N=32	1680- 1689 N=32	1690- 1699 N=36
Milk tray/pan	1	16	8	2
Tray		5	7	10
Churn		4	4	4
Butter tub		3	3	2
Cheese vat			2	
Bread tray	1	2	1	4
Tub	1	6	4	9
Powdering tub		2	1	5
Brewing tub	1		1	1
Cooler		3		
Pail		11	16	18
Piggin		3	4	9

Table 9. Vessels Used in Food Preparation and Processing (Not in Cooking) Infrequently Mentioned in Estate Inventories from County Court Records

York County
(1638-1699)

Brewing tub
Brewing pot
Beer cooler
Cider trough
Water cooler
Milk pail
Milk piggin
Water pail
Bucket

Surry County
(1663-1699)

Butter tray
Bucket

Table 10. Mention in Estate Inventories of Equipment Used in Food Preparation and Processing (Not in Cooking), York County Court Records, 1638-1699

	1630- 1639*	1640- 1649	1650- 1659	1660- 1669	1670- 1679	1680- 1689	1690- 1699
	N=1	N=8	N=19	N=27	N=33	N=44	N=54
Mortar & pestle		1	2	14	12	16	23
Pestle		5	9	21	19	25	26
Grater				4	5	5	6
Bread grater				3	1	2	
Spice grater				1		2	
Scale & weights		1	2	5	4	5	9
Knife/cleaver		2	7	9	6	5	17
Mill				4	2	1	2
Rolling pin					2	1	2
Tray			8	9	16	22	19
Sifting tray			4	7	4	6	8
Meal tray				1	3		1
Meal sifter/sieve				1	9	12	
Hominy sifter/sieve		1		1	3	1	
Sieve							5
Sifter			3	12	13	12	14
Flour box			1		1	1	
Strainer				3			4
Skimmer			5	11	10	8	22
Colander			1	6	3	8	6
Funnel				3	5	4	8
Cheese press/paise		1	1	3	3	1	4
Still		1	1	1	2	3	4
Stillyards		2	2	11	13	14	17

*The single inventory for this decade is dated 1638.

Table 11. Mention in Estate Inventories of Equipment Used in Food Preparation and Processing (Not in Cooking), Surry County Court Records, 1663-1699

	1663- 1669 N=4	1670- 1679 N=32	1680- 1689 N=32	1690- 1699 N=36
Mortar & pestle		8	11	15
Pestle		7	13	12
Scale & weights		1		2
Knife/cleaver		7	11	5
Sifting tray		6	4	2
Wheat sieve/sifter			2	3
Meal sifter/sieve		5	4	6
Hominy sifter/sieve			1	2
Sifter	1	4	10	7
Hair sifter		2		1
Strainer		1	1	1
Skimmer	1	11	7	6
Colander		2	1	1
Funnel		2	3	2
Stillyards	1	12	15	15

Table 12. Equipment Used in Food Preparation and Processing
(Not in Cooking) Infrequently Mentioned in Estate
Inventories from County Court Records

York County
(1638-1699)

Churn stick
Butter print
Cheese mold
Screw cheese press
Sifter bottom
Sifter rim
Wheat sifter
Sifting bag
Hair sifter
Pepper mill
Malt mill
Steel mill
Hand mill
Small pair hand
mill stones
Horse mill
Beer stands
Horse

Surry County
(1663-1699)

Straining bowl
Skimming dish
Meal tray
Sieve
Rolling pin
Grater
Bread grater
Still

Except for earthenware milk pans and pots used over a fire (as in brewing), preparation and processing vessels were generally made of wood, products of the cooper's craft. Only the metal hoops have survived as artifacts. Tubs are large open wooden vessels, greater in width than in height. Randle Holme explains the names of a tub (shown in Figure 14) in relation to its size: "This containeing halfe a Barrell of water, or something lesse, is called a Tub; if lesse a Tubnell, that is vulgarly a Turnell: if larger, then it is, a *Fate*, or *Vate*" (p. 18). Settlers used powdering tubs for salting meat (*powdering* means salting), cheese vats for breaking and kneading cheese curds, and butter tubs for salting butter or perhaps even for making butter when churns were not available. Churns were probably the upright, round narrow type with a staff. Coolers generally served a less active purpose, holding liquid while it cooled or rested. Pails, piggins, and buckets served as vessels for collecting and carrying small volumes of liquids, especially milk and water. Pails and piggins were generally wood, with a pail having a hooped wire handle across the top and a piggin having a single fixed upright wooden handle at the side. Buckets were sometimes tin.

In addition to the metal skimmers described earlier with the cooking utensils (see Plate 14), broad flat skimming dishes or bowls were used in dairying. The presence of the cheese press and the cheese paise, especially in York County inventories, indicates that cheese making was a serious rather than casual activity. The cheese

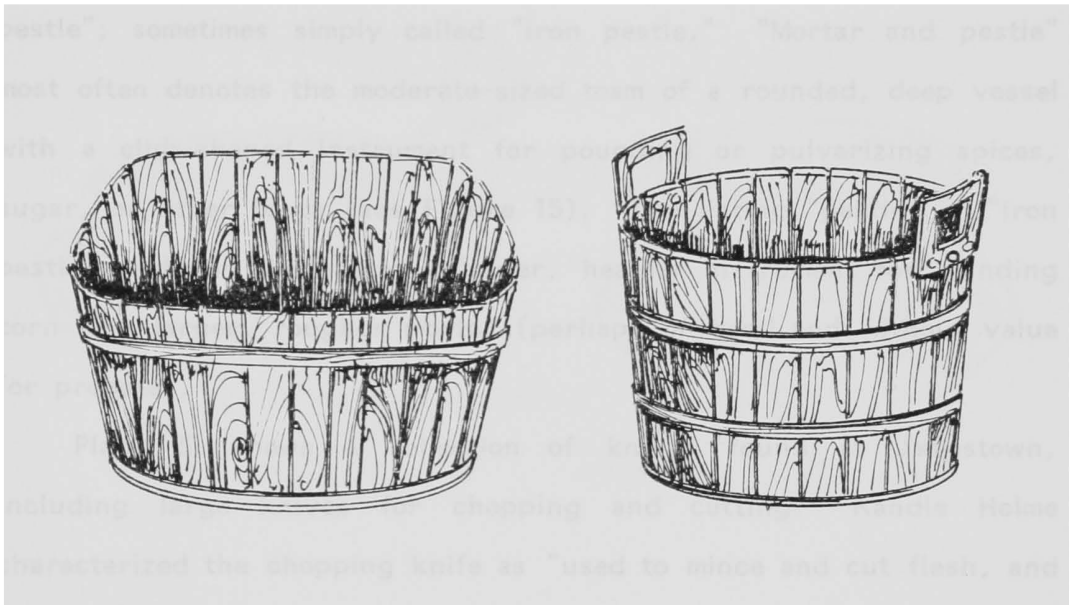

Figure 14. On the left, a wooden tub drawn from Randle Holme (illustration 93 facing p. 18); on the right, a handled tub or turnell also from Holme (illustration 58 facing p. 18).

press compressed cheese curd to expel whey and moisture, while the cheese paise was a weight; one York County inventory mentions a screw cheese press.¹⁶

Mortars and pestles appear frequently in inventories: sometimes mentioned as "mortar and pestle" and identified as brass, wood, bellmetal, or alabaster; sometimes specified as "spice mortar and pestle"; sometimes simply called "iron pestle." "Mortar and pestle" most often denotes the moderate-sized team of a rounded, deep vessel with a club-shaped instrument for pounding or pulverizing spices, sugar, or other foods (see Figure 15). The listing "pestle" or "iron pestle" probably designates a larger, heavier instrument for grinding corn in a larger, rougher mortar (perhaps of wood and without value for probate).

Plate 23 shows a collection of knives found at Jamestown, including large knives for chopping and cutting. Randle Holme characterized the chopping knife as "used to mince and cut flesh, and herbs small" (p. 3). Appearing frequently in inventories, the name *chopping knife* is an alternate label for *randing knife*, or a knife for cutting meat into strips. Some knives listed in inventories—cutting knives and drawing knives—were used in coopering, not in food preparation. Plate 24 shows an unusual cutting tool, an apple corer made from a bone. Although I have not found a picture of a bread

¹⁶ A screw cheese press is illustrated in Dorothy Hartley, *Lost Country Life* (New York: Pantheon Books, 1979), p. 109. Also illustrated are a churn, p. 102; and cream pot, milk cooler, and skimmer, p. 104.



Figure 15. A mortar and pestle (left) and a mortar (right). Drawn from Randle Holme, illustrations 56 and 57 facing p. 18.

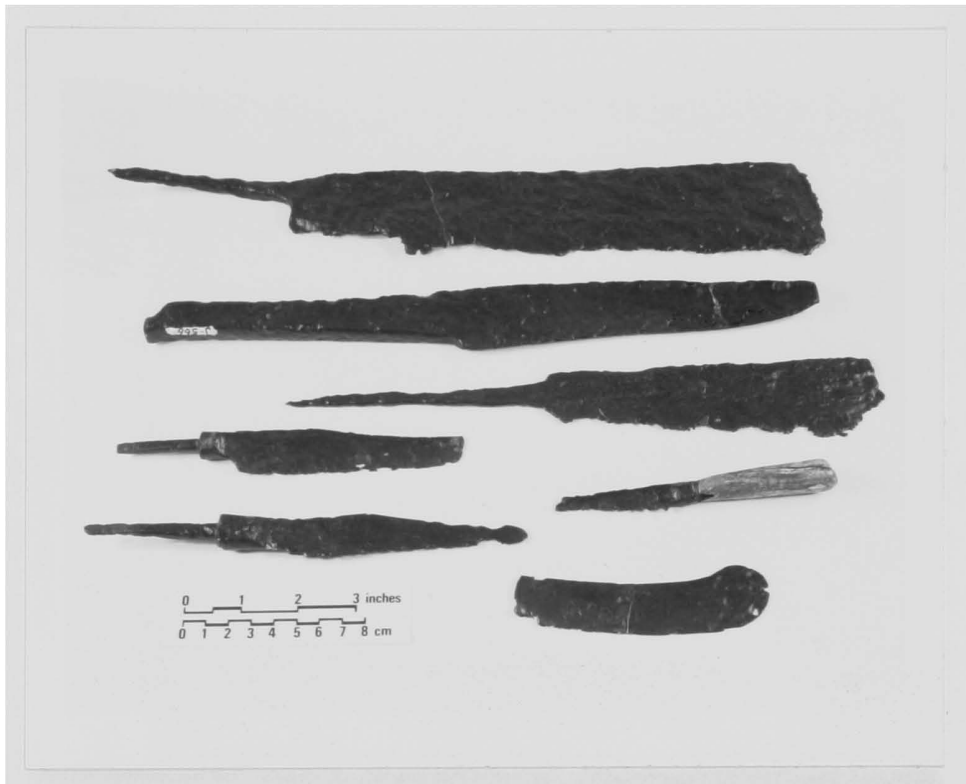

Plate 23. Knives found at Jamestown. The second blade from the top is a cleaver. The smaller knives at the bottom of the photograph are fruit knives and dinner knives; the rounded blade at the bottom is typical of the eighteenth century, not the seventeenth. Photographed courtesy of National Colonial Historical Park, National Park Service, Jamestown; J-975, J-566, J-8681, J-11321, J-3951, J-95, J-236 (numbers listed from the top).

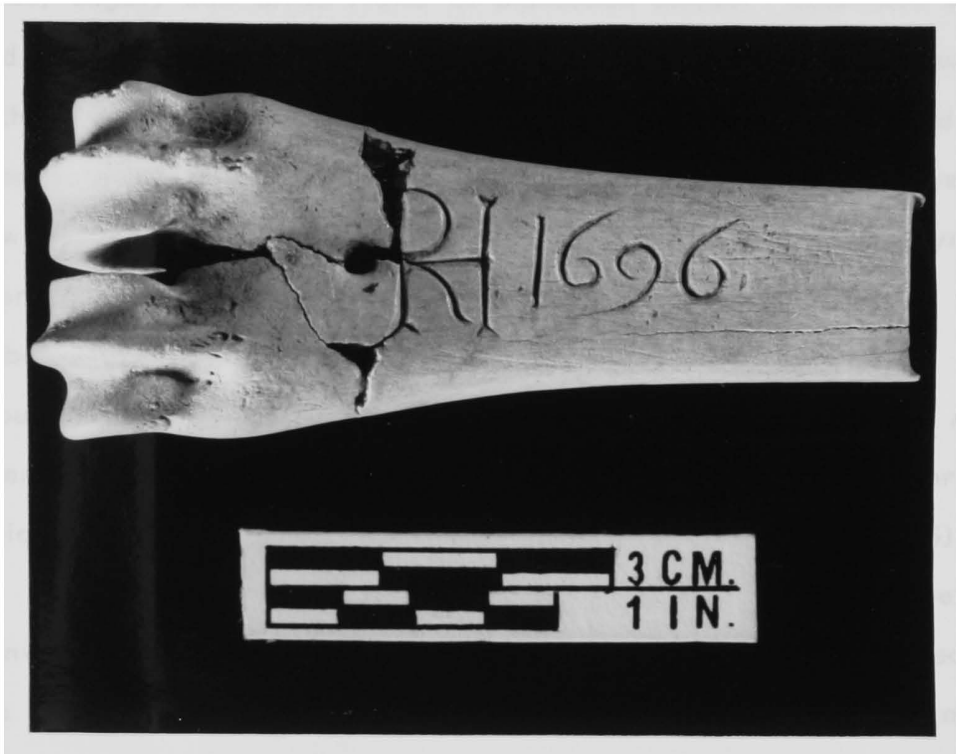

Plate 24. An apple corer inscribed with the date 1696, found at the College Landing site in James City County in an archaeological context of 1720-1740. The corer is made from a bone; its gouge section is missing. Photograph courtesy of Virginia Research Center for Archaeology; CL 113D.

grater (a scraper), a rather elaborate rasping grater appears in a Bruegel drawing (see Plate 25).¹⁷

Scales and weights may have been used to weigh ingredients in food preparation; they were certainly used in trade, in the sale of spices, sugar, and dried fruits at plantation stores. Colanders were used both in dairying and for washing or draining foods. A coarse earthen colander is shown in Plate 14; colanders mentioned in inventories are generally tin, sometimes copper or brass. Figure 16 shows a metal colander described by Randle Holme as "made of Tyn or other mettle, haveing the bottome full of small round holes; in this Herbes or such like things are washed, whose dirt and filth run through the holes, leaveing them pure and cleane" (p. 11). Also generally of tin, funnels were probably used for the transfer of liquids (cider, beer, wine) from casks to bottles (Plates 18 and 26).

As equipment for brewing, pairs of stillyards figure prominently in inventories. Frames to hold casks, they are sometimes described as with or without pens. Stills are occasionally mentioned, but the name presents a problem: *still* is an alternate name for *cooler*. We know from documentary records, however, that early Virginians distilled spirits, and the top element of a pottery still was found at Wolstenholme Towne.¹⁸ A similar still top appears in a Bruegel

¹⁷ In an example of improvised cooking tools, bones of sturgeons sometimes served as nutmeg graters. See John Lawson, *A New Voyage to Carolina* (1709), ed. Hugh Talmage Lefler (Chapel Hill: Univ. of North Carolina Press, 1967), p. 162.

¹⁸ See Ivor Noel Hume, "First Look at a Lost Virginia Settlement," *National Geographic*, 155 (June 1979), p. 754.



Plate 25. A grater (center foreground) shown in a detail from Bruegel's "The Rich Kitchen" (Klein, *Graphic Worlds*, plate 36). To the right is a large stone mortar and pestle.

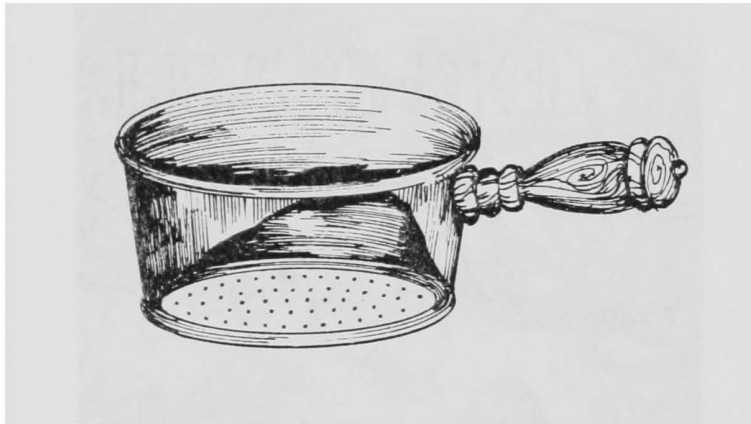

Figure 16. Colander drawn from Randle Holme (illustration 53 facing p. 18).

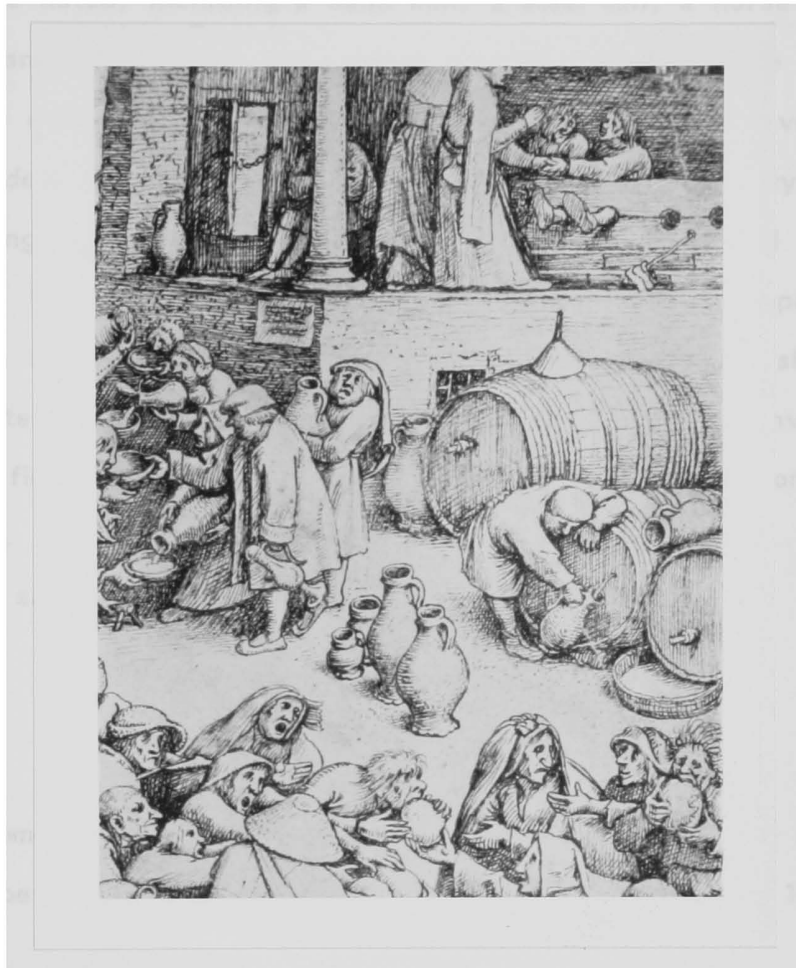

Plate 26. Casks shown in a detail from a Bruegel drawing, along with jugs and—atop one of the casks—a funnel. From Klein, *Graphic Worlds*, plate 50.

drawing of an alchemist's laboratory (see Plate 27).

Many items listed in inventories relate to grain milling. Only a few mills are listed, including a hand mill, a steel mill, a horse mill, a malt mill, and small hand mill stones (which indicate stone milling rather than cutting).¹⁹ The rolling pins mentioned could have been either cylinders for rolling out dough and pastry, or heavier cylinders for threshing grain. The miscellaneous trays, sieves, and sifters served for bolting—separating flour from bran—or for separating coarse corn (hominy) from the finer flour (meal). Plate 28 shows a sieve or sifter from a seventeenth-century drawing. A final inventory item, the flour box, provides yet another example of confusing terminology. Rather than a large container for storing flour, it is a tin box—or shaker—for dredging flour.

STORAGE

The somewhat scanty inventory data about containers for storing foods and beverages is presented in the following Tables 13, 14, and 15.

¹⁹ An iron hand mill from the mid-seventeenth century was found at the Denbigh plantation in Warwick County. Perhaps used for grinding grain, the mill is described and illustrated in Noel Hume, *Food*, pp. 63-64.

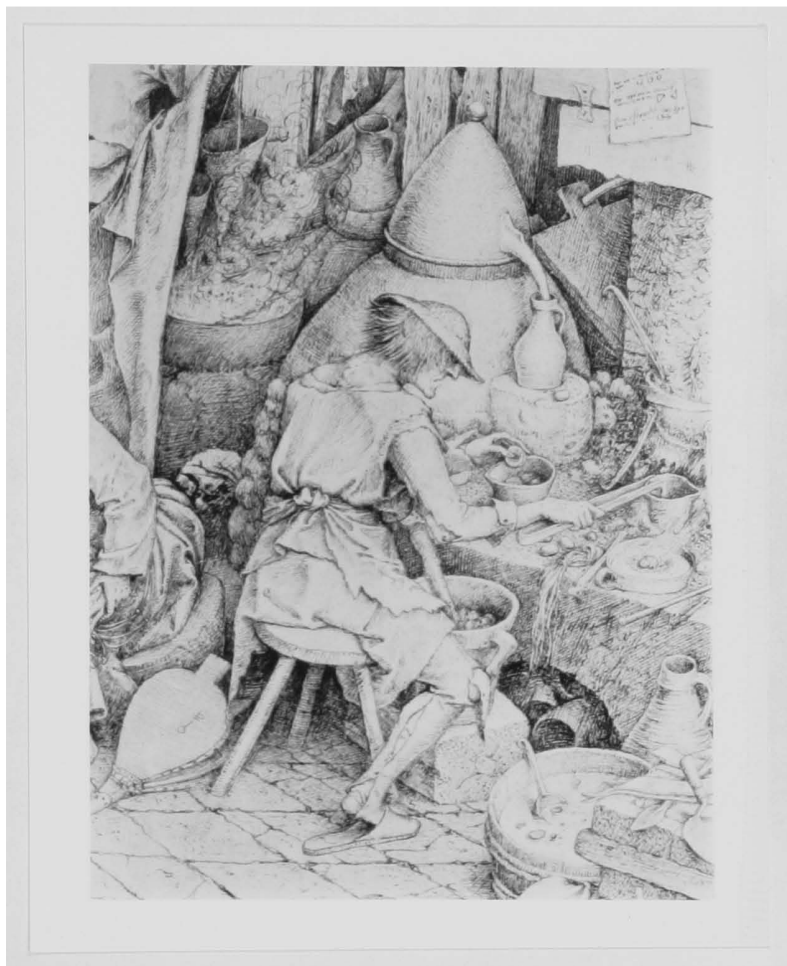

Plate 27. Detail from a Bruegel drawing which shows an alchemist using distilling apparatus with a top similar to the one found at Wolstenholme Towne. From Klein, *Graphic Worlds*, plate 38.

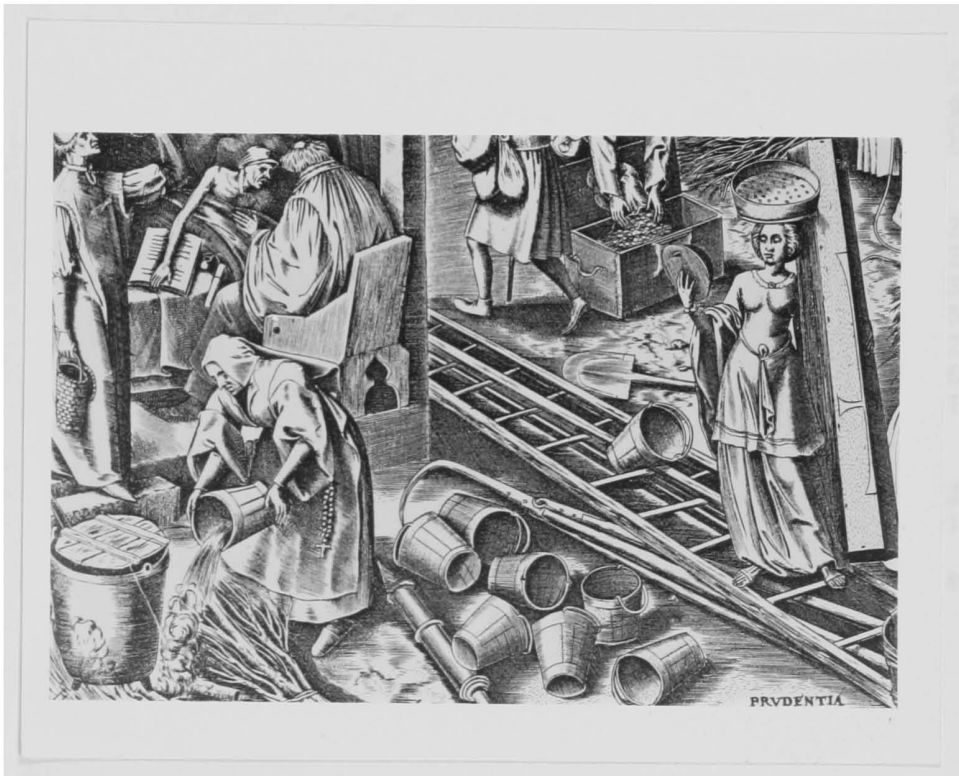

Plate 28. Detail from a Bruegel drawing showing a sieve or sifter on the head of Prudence. Wooden pails are at the left. From Klein, *Graphic Worlds*, plate 52.

Table 13. Mention in Estate Inventories of Food and Beverage Storage Containers, York County Court Records, 1638-1699

	1630- 1639*	1640- 1649	1650- 1659	1660- 1669	1670- 1679	1680- 1689	1690- 1699
	N=1	N=8	N=19	N=27	N=33	N=44	N=54
FOOD CONTAINERS							
Flower chest						1	2
Salt box						1	2
Spice box					1	2	3
Safe					1	1	5
Jar				2		1	2
Butter pot				2		2	6
Barrel	1	1	3	11	2	10	11
BEVERAGE CONTAINERS							
Cask			3	4	7	21	12
Cider cask					2	6	11
Beer cask		1				2	
Runlet			4	9	5	13	8

*The single inventory for this decade is dated 1638.

Table 14. Mention in Estate Inventories of Food and Beverage Storage Containers, Surry County Court Records, 1663-1699

	1663- 1669 N=4	1670- 1679 N=32	1680- 1689 N=32	1690- 1699 N=36
FOOD CONTAINERS				
Butter pot		5	5	7
Barrel		5	5	6
Corn/meal barrel		1	1	3
BEVERAGE CONTAINERS				
Cask		5	6	7
Cider cask		1		3
Beer cask		2		2
Runlet	1	6	5	5

Table 15. Vessels for Food and Beverage Storage Mentioned
Infrequently in Estate Inventories from County Court
Records

York County
(1638-1699)

Flour barrel
Mackerel barrel
Meal tub
Firkin
Cream pot
Oil jar
Sugar box
Jelly pot
Pie box
Wine cask

Surry County
(1663-1699)

Safe
Salt box
Spice box
Jar
Cream pot

Wooden barrels and casks held the early Virginian's stores of salted pork and cider. Because all foods except small game and some seafood were seasonal, householders who failed to preserve and store provisions faced either meager or monotonous diets as the food supply shifted with the seasons. Itemized estate inventories sometimes refer to barrels and casks by their contents and thus reveal both the food stored and its container: mackerel barrels, flour barrels, barrels of corn and meal, cider casks, beer casks, wine casks.

In the barrel family, names denote a hierarchy of size or volume. Largest of all is the tun—eight times as large as a barrel—used often in trade, rarely if ever in households. Smallest is the firkin, a fourth the size of a barrel, for foods such as butter or fish which are logically stored in smaller volumes.²⁰ Although sometimes considered synonymous with barrels, casks were generally used for liquids; a practical distinction in the use of barrels and casks is that barrels stand upright and have a loose lid, while casks sometimes rest on their sides and have various taps or cocks for dispensing fluid contents. Although planters ordered large casks of wine called pipes (half a tun, or 126 old wine-gallons), I have not found pipes mentioned in York or Surry inventories. The most frequently mentioned casks for liquids are runlets, which do not have a fixed volume and were not used as a unit of measure; inventories list

²⁰ In today's terms, a barrel holds thirty-one gallons or about four dry bushels, but colonial coopers did not control the volumes of their staved and hooped products.

runlets with capacities varying from two to sixty gallons.

Casks of cider and barrels of salted meat were apparently stored whenever possible in cool cellars, whereas grain and dried meat benefitted from the warmer, drier conditions of lofts. Grain was often stored in cloth bags (inventories mention "meal bags"), as well as in barrels. Although inventories sometimes include over a hundred pounds of dried pork or beef, neither they nor documentary sources suggest how settlers stored dried meat. Vermin, as well as atmospheric conditions, threatened stored food, and some inventories mention a safe: a ventilated chest or cupboard designed to protect provisions from animal attack. Although Randle Holme provides a drawing and description of an elaborate safe (see Figure 17), settlers perhaps had various improvised, rough vermin barriers which have survived neither as artifacts nor as inventory entries.

Among the storage containers which do appear in inventories, mention of salt boxes and spice boxes shows the value of those commodities. Although pepper boxes were pepper *shakers*, salt boxes were indeed boxes, for storing salt in the kitchen (Plate 29 shows both a salt box and a large wooden barrel). Spice boxes usually had several compartments for storage of individual spices.

Ceramics—earthenware and stoneware—comprise the artifacts which were used for food and beverage storage. Butter pots appear in both inventories and artifact assemblages (see Plate 30). Salted butter was packed tightly (to exclude air) into the narrow, deep



Figure 17. A safe described by Randle Holme as " a kind of little house made of wood and covered with haire cloth, and so by two rings hung in the midle of a Rome, thereby to secure all things put therein from the cruelty of devouring Rats, mice, Weesels, and such kind of Vermine. Some have the pannells of the Arke made all of Tyn, with small holes for aire; others of woode" (p. 17). Drawn from illustration 88 facing p. 18.

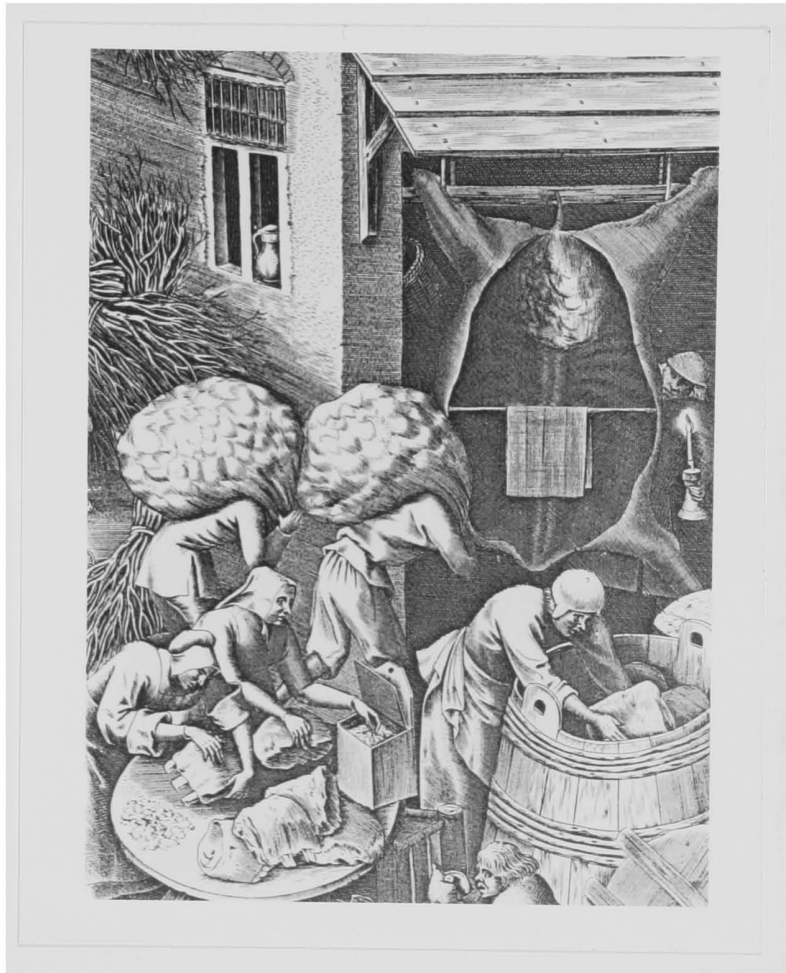

Plate 29. Detail from a Bruegel drawing showing women salting meat. On the work table is a salt box; the women are placing the meat in a large wooden barrel whose cover is in the bottom right corner. Drawing from Klein, *Graphic Worlds*, plate 52.



Plate 30. Staffordshire Midlands purple butter pot found at the Maine site in James City County. Archaeological context, 1618-1625. Photograph courtesy of Virginia Research Center for Archaeology; GL 13, 13A, 13B, 13C, 13F, 13H, 146A.

vessels. Other fats or potted foods also may have been stored in butter pots or in earthenware jars like the ones shown in Plates 31 and 32; these jars could have been used also for pickled or brined foods. Plate 33 shows a locally made pot or jar found at Jamestown; vessels like this could have been used for cooking as well as for storage—similarly shaped vessels are shown in pictures of Indians cooking.²¹ Plate 34 shows a small vessel that might have been used for either cooking or storage; it is so small, however, that storage of a fat (such as lard) or use as a mixing or serving bowl seems more likely than use as a small cooking pot.

The Iberian olive jar in Plate 35 is an example both of the Portugese and Spanish wares found at archaeological sites and of vessels used for more than their original specialized purposes. Designed to hold olives or olive oil, this vessel may have been used by its Virginia owner for storing any liquid—oil, water, or even cider or beer. Cider, beer, and wine were generally stored in casks and transferred into bottles only for serving; thus bottles are discussed in Chapter 7, Dining and Drinking.

²¹ See the Theodor de Bry engraving of John White's watercolor painting in Thomas Harriot, *A Brief and True Report of the New Found Land of Virginia* (Frankfurt, 1590; rpt. New York: Dover, 1972), p. 60.

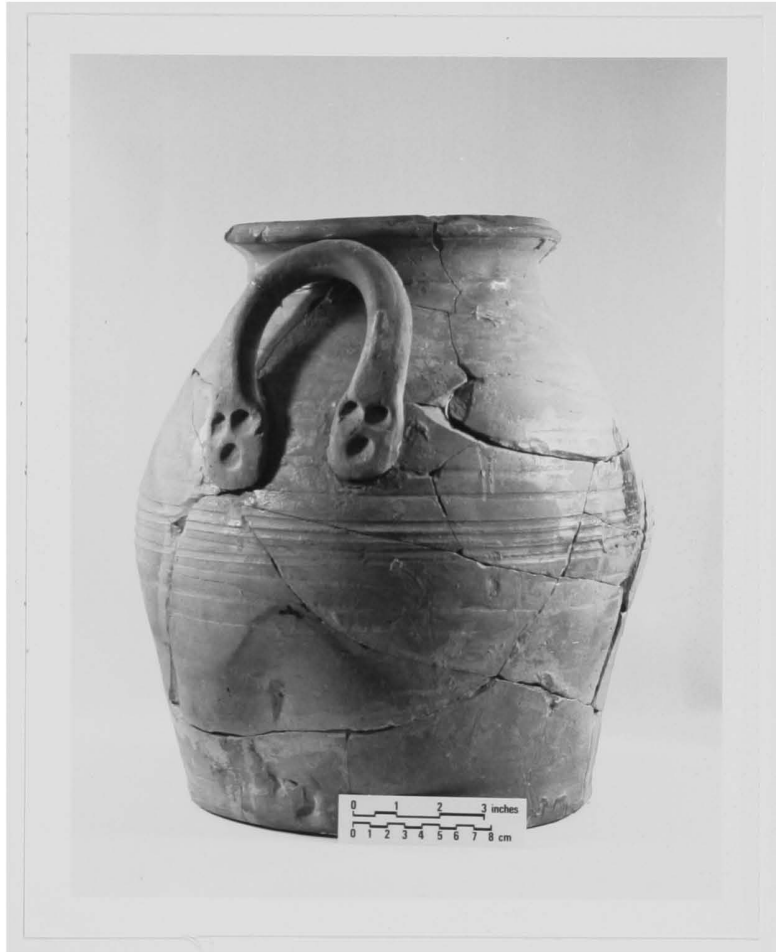

Plate 31. Lead-glazed earthenware storage jar found at Jamestown, possibly made at the Green Spring kiln. Height 37 cm; artifact date c. 1650-1700. Photographed courtesy of National Colonial Historical Park, National Park Service, Jamestown; J-7604.



Plate 32. Coarse earthenware storage jar found at Jamestown. Locally made, with finger-marked fillet around rim; height 24 cm. Photographed courtesy of National Colonial Historical Park, National Park Service, Jamestown; J-7008.

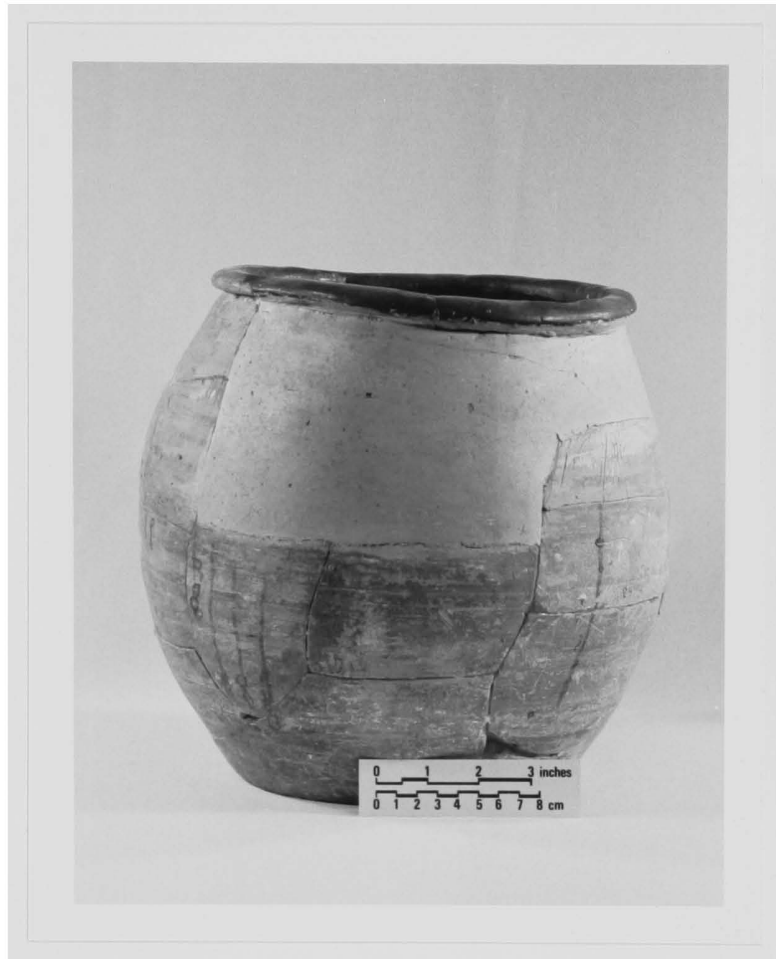

Plate 33. Earthen jar or pot found at Jamestown, made at the local Challis site (1690-1730 period). Height 23 cm. Photographed courtesy of National Colonial Historical Park, National Park Service, Jamestown; J-7605.



Plate 34. A small earthen jar or pot found at Jamestown, made at the local Challis site (1690-1730 period). Height 12 cm; diameter at top 17 cm. Photographed courtesy of National Colonial Historical Park, National Park Service, Jamesown; J-7588.



Plate 35. Iberian olive jar found at the Maine site in James City County. Archaeological context 1618-1625; artifact date 1580-1780. Photograph courtesy of Virginia Research Center for Archaeology; GL 109A.

Chapter 6

COOKS AND THEIR METHODS

Demographic data shatter facile assumptions about food preparers in seventeenth-century Virginia. Men, not women, were responsible for much food preparation; only in large, affluent households was food generally prepared by women servants, and wives of small planters more likely worked in the fields than created dainty dishes.

Immigrant men outnumbered women by six to one early in the century, by two and a half to one at its end. Since women servants could not marry during their terms of indentureship, wives were especially scarce; many bachelors established all-male households, and even wealthy widowers often failed to remarry. Although wealthy planters could afford servants for domestic duties, small planters in the labor-short colony gave priority to field labor—a planter who could afford only one servant would logically prefer a man, not a woman. Some inventories do mention a woman as the only servant, but the male householder may have had hired rather than indentured workers or fellow male householders. Only seventeen percent of the York County inventories from 1638 to 1699 include women servants, and only four percent of the estates appraised had two or more women servants. Of Surry County inventories from 1663 to 1699, only four percent included one woman servant, and none had two or more. Eighteen percent of the York and five percent of the Surry

inventories mention female slaves, but female slaves almost always worked in the fields, not in the house. Since estate inventories rarely represent young men likely to be unmarried and short of possessions, the percentage of households with women servants may have been even less than these figures suggest. Tables 16 and 17, which follow, present estate inventory data about servants and slaves.

Table 16. Mention in Estate Inventories of Servants and Slaves, York County Court Records, 1638-1699

	1630- 1639*	1640- 1649	1650- 1659	1660- 1669	1670- 1679	1680- 1689	1690- 1699
	N=1	N=8	N=19	N=27	N=33	N=44	N=54
SERVANTS							
Male servant(s)			1	13	11	9	4
One female servant	1		2	5	6	6	4
Two or more female servants			2	4			1
Undifferentiated servants		1	1		1		
SLAVES							
Male negro(es)		1		1	4	8	18
Female negro(es)		1		7	3	7	16
Undifferentiated negro(es)				1	1		2

*The single inventory for this decade is dated 1638.

Table 17. Mention in Estate Inventories of Servants and Slaves,
 Surry County Court Records, 1663-1699

	1663- 1669 N=4	1670- 1679 N=32	1680- 1689 N=32	1690- 1699 N=36
SERVANTS				
Male servant(s)		2	1	2
One female servant		3	1	
Two or more female servants				
Undifferentiated servants			1	
SLAVES				
Male negro(es)		2	1	5
Female negro(es)				5
Undifferentiated negro(es)				1

In the English yeoman tradition, food production and processing—care of the home garden and livestock, dairying, salting meat, brewing, and baking—were the housewife's duties, and that pattern continued for Virginia housewives whose responsibilities were neither light nor slight. Even if a wife attended only to household duties and did not help in the fields, she ground and pounded corn for bread, milked cows, made butter and cheese, grew and dried vegetables, cared for poultry, made cider and beer, dressed game and household livestock, salted meat and fish. She also cared for children, made and washed clothes, and fought the vagaries of season and climate.¹ According to Lawson's account, women in North Carolina also managed canoes "with great Dexterity and Skill" and helped their husbands with planting, "Pride seldom banishing good Houswifry."²

From the scant and sketchy information about domestic labor, three possible household patterns emerge:

- 1) all-male households where domestic labor and comforts were probably rudimentary at best because of preoccupation with tobacco growing and lack of resources,
- 2) small family-centered households with a woman serving as housewife-manager-worker, sometimes assisted by children and only occasionally by a servant, and

¹ See Lois Green Carr and Lorena S. Walsh, "The Planter's Wife: The Experience of White Women in Seventeenth-Century Maryland," *William and Mary Quarterly*, 3d Ser., 34 (Oct. 1977), 542-71.

² John Lawson, *A New Voyage to Carolina* (1709), ed. Hugh Talmage Lefler (Chapel Hill: Univ. of North Carolina Press, 1967), p. 91.

- 3) larger, more affluent households with one or more women servants doing the domestic work, sometimes without a housewife-manager.

Food preparation equipment, and therefore provision for food preparation activities, also falls into patterns reflecting status and type of household. Inventories of bachelors' estates sometimes mention little more than clothing, a bed, a few livestock, some corn and tobacco, a knife, an iron pot, and a frying pan. Food-related equipage for many bachelor households probably also included wooden pails and barrels, a wooden mortar and pestle for pounding corn, earthen pots, and wooden plates, bowls, and spoons. Inventories of small estates rarely mention andirons, spits, or dripping pans, but stones may have served for andirons, sticks for spits. Even with limited equipment, however, a solitary tobacco farmer could boil, stew, fry, and roast or barbecue. He probably had no oven, made no bread other than rough pone, made no butter or cheese (although he probably used milk), and purchased or traded for cider or beer. Even more than limited facilities and equipment, lack of time, skills, and incentive probably restricted his food preparation and his cuisine.

Wives and women servants were generally trained in traditional housewife duties such as dairying, baking, brewing, and the dressing and preservation of meat. Inventories of middling estates usually include a greater variety of cooking equipment than do small estates: pots, kettles, frying pans, skillets, gridirons, andirons, spits, and dripping pans, along with mortars and pestles, ladles, skimmers, and

colanders. These housewives frequently had vessels and equipment for specialized activities; inventories mention milk pans, meal sieves, bread trays, casks, and stillyards. Many housewives probably lacked ovens, and if they had time and resources for more sophisticated preparations of pies, wheat bread, custards, and hard cheese, they may have used improvised or make-shift equipment.

Larger, more affluent households with servants had both greater volume and greater variety of equipment for food-related activities. Whereas the typical middling households had only one each of many kinds of vessels and equipment, the large estates usually had several of each kind of basic vessel and even multiple spits, mortars, colanders, and stillyards. Pie pans and pudding pans appear with some frequency in these inventories, along with specialized utensils like toasting forks and apple roasters. Handmills and wheat sieves indicate the preparation of wheat bread, while churns, butter pots, cheese vats, and cheese presses indicate serious dairying, perhaps on a large scale. Large households also had equipment for large-scale brewing and cider production: brewing tubs, casks, and runlets, with malt and hops sometimes also listed in inventories.

Experience, not cookbooks, directed seventeenth-century Virginia's cooks. Women who came as servants were poorly educated, usually illiterate—and these were the women who became wives. Standard English cookbooks of the period give only vague, general directions for roasting meat, making pies, or baking bread; no

housewife could have learned to cook by reading, even if she could read.³ These women—whether wives or servants—probably learned food preparation techniques from their mothers, and they probably possessed "macro" or basic skills (dairying, baking, simple cooking) rather than "micro" refinements such as skills in poaching fish or distilling apricot brandy. Skills in preserving meat and fish, enterprise in storing root vegetables and drying legumes, and resourcefulness in taking maximum advantage of seasonal foods were more important than the style of preparing food.

Documentary sources reveal almost nothing about how foods were cooked in seventeenth-century Virginia. The few limited descriptions suggest that fresh meat and poultry were generally spit-roasted, probably basted with their own fat and perhaps seasoned with salt and herbs, sometimes dredged with flour to make a crisp coating (the purpose, apparently, of the flour boxes mentioned in inventories). Salted meat was sometimes roasted, often cooked with hominy or legumes, sometimes part of a boiled dinner with vegetables. Michel mentions a meal of "small white beans, cooked with bacon"; practical dishes like that were surely common.⁴ Although many sources refer to salted meat, none I examined mention smoking, a preservation

³ A cookbook widely available and popular in England was Markham's *The English Huswife*, currently available in a facsimile printing in Gervase Markham, *Countrie Contentments* (London, 1615; rpt. Amsterdam: Theatrum Orbis Terrarum, 1973).

⁴ "Report of the Journey of Francis Louis Michel from Berne, Switzerland, to Virginia, October 2, 1701–December 1, 1792," trans. and ed. William J. Hinke, *Virginia Magazine of History and Biography*, 24 (1916), 114.

technique common in England. Meat was sometimes dry-salted, sometimes packed in brine; a sixteenth-century drawing of women salting meat is shown in Plate 29, Chapter V.

Virginians probably often fried fish or broiled it on a gridiron; some early writers mention fish so fat it could be fried without adding additional fat to the pan.⁵ Pickled fish and shellfish may have been eaten without cooking. Accounts by early adventurers describe unusual techniques for preserving fish or preparing dishes with dried fish, but later accounts neither confirm those unusual methods nor describe similar preparations.⁶

Early writers rarely give clues to the preparation of vegetables, fruits, meat pies, puddings, and custards. Dried legumes were boiled, often with meat. Beverley writes, at the end of the century, that the native herbs, squashes, and flowers were used as "Sauce" to fresh and salted meats, that squash was "boil'd whole, when the Apple

⁵ Lawson, *New Voyage*, p. 160; Excerpt from a letter [from Francis Perkins?], in *The Genesis of the United States*, ed. Alexander Brown, Vol. I (1890; rpt. New York: Russell and Russell, 1964), p. 175.

⁶ An attempt to preserve oysters by boiling and bottling is described in Colonel Norwood, "A Voyage to Virginia," in *Tracts and Other Papers*, ed. Peter Force, Vol. III, No. 10 (1844; rpt. New York: Peter Smith, 1947), p. 26. John Smith describes pounded dried sturgeon mixed with caviar and sorrel, in "The Proceedings of the English colony in Virginia," in *The Extension of Settlement in Florida, Virginia, and the Spanish Southwest*, Vol. 5 of *New American World*, ed. David B. Quinn (New York: Arno Press, 1979), p. 338. For mention of caviar and of sturgeon not "well boyled," see "Instructions for such things as are to be sente from Virginia, 1610," in *The Genesis of the United States*, p. 386.

is young, and the Shell tender, and dished with Cream or Butter."⁷ The appearance in estate inventories of apple roasters indicates that apples and perhaps other fruits were roasted at a fire; fruit was probably also stewed and baked. Writers mention fruit tarts without suggesting how they were made, and a few inventories include pie pans, custard pans, and pudding pans. Since fruit pies, meat pies, and custards were popular in England, they were probably also made in Virginia. Pudding could have been cooked in a pan (the shape and size of a milk pan) or boiled in a cloth. Colonel Norwood describes a somewhat forlorn pudding contrived at sea, little more than spiced and fruited fried mush:

Many sorrowful days and nights we spun out in this manner [on board ship], till the blessed feast of *Christmas* came upon us, which we began with a very melancholy solemnity; and yet, to make some distinction of times, the scrapings of the meal-tubs were all amassed together to compose a pudding. *Malaga* sack, sea water, with fruit and spice, all well fryed in oyl, were the ingredients of this regale, which raised some envy in the spectators; but allowing some privilege to the captain's mess, we met no obstruction, but did peaceably enjoy our *Christmas* pudding.⁸

Just as earlier writers like John Smith describe the Indian ways of making bread with corn, European travelers later in the century describe—in much less detail—the way colonists made corn bread. Jasper Danckaerts writes that the finest meal was used for bread.

⁷ Robert Beverley, *The History and Present State of Virginia* (1705), ed. Louis B. Wright (Chapel Hill: Univ. of North Carolina Press, 1947), pp. 142, 292.

⁸ "A Voyage to Virginia," in *Tracts and Other Papers*, p. 17.

The meal intended for bread is kneaded moist without leaven or yeast, salt or grease, and generally comes out of the oven so that it will hardly hold together, and so blue and moist that it is as heavy as dough; yet the best of it when cut and roasted, tastes almost like warm white bread, at least it then seemed to us so.⁹

Documentary sources do not describe the making of wheat bread, beer, cider, or cheese, or tell how meat and fish were dried and salted. Settlers probably used the traditional English methods. Wheat bread could have been leavened with barm from beer or with sourdough starter saved from previous bakings. Beer production depended generally upon malt and hops (both of which were available but not easy to buy or produce at home), and cider only required mashed and pressed ripe fruit. Either natural bacteria or rennet could have curdled milk for cheese; rennet may have been difficult to obtain, since it was extracted from a calf's stomach and calves were slaughtered infrequently. Mention in inventories of salt, powdering tubs, and barrels suggests simple, straightforward salting operations.

English sources for the period give only vague, general descriptions of these central methods of food processing: baking, brewing, dairying, and meat preservation. From such inexact, incomplete information we cannot tell what foods were like; we cannot duplicate them, or recreate the food preparation processes and techniques. Food preparation in the seventeenth century may have been like riding a bicycle in the twentieth; cooks learned to prepare

⁹ *Journal of Jasper Danckaerts 1679-1680*, ed. Bartlett Burleigh James and J. Franklin Jameson (1913; rpt. New York: Barnes and Noble, 1952), p. 134.

food from people, not from books, and the skills were so assimilated into the fabric of inarticulate daily life that they defy identification and analysis.

Chapter 7

DINING AND DRINKING

Although cooking vessels provide useful clues to the ways food was prepared in seventeenth-century Virginia, eating and drinking vessels reveal little about meal patterns or dining customs. Plates and bowls do not proclaim the combinations of foods they held or the time of day they were used; they do not evoke a process or activity in the way a churn or gridiron does. Yet eating and drinking vessels do suggest the economic status, aesthetic values, and sometimes the table demeanor of their owners.

Because ceramics comprise most of the archaeological artifacts relating to eating and drinking, and metals (pewter, silver, and alloys such as latten) comprise much of the dining and drinking vessels listed in probate inventories, artifacts and inventories generally provide different rather than common data. Estate inventories can present the researcher with tricky problems in interpreting data on dining and drinking paraphernalia. For example, because pewter spoons had greater value than wooden spoons, the dramatic increase through the century in the frequency with which spoons appear in York County inventories indicates not that spoons became more widely used as the century progressed, but that the populace became more affluent and material goods more available—pewter spoons gradually replaced wooden spoons. The progressive increase in the frequency

of plates, however, may tell a different story, especially since inventories often mention ceramic plates and occasionally even list wooden plates. Early in the century communal eating was the general custom; diners shared platters or bowls of food and large drinking vessels were passed around the company. With time, however, eating and drinking became individual, and individual vessels were, of course, smaller than communal vessels. Because plates are individual, their progressive increase in frequency may indicate a progressive shift from group to individual eating. Terminology also presents problems with dining vessels; the cisterns mentioned in a York County inventory probably were large bowls for rinsing plates, not receptacles for storing water.¹ Tables 18 through 22, which follow, present the estate inventory data on dining and drinking vessels and utensils.

¹ See Worth Bailey, "Notes on the Use of Pewter in Virginia During the Seventeenth Century," *William and Mary Quarterly*, 2d Ser., 18 (April 1938), 234.

Table 18. Mention in Estate Inventories of Table Linens, Silver, Eating Utensils, and Vessels for Food Service and Dining, York County Court Records, 1638-1699

	1630- 1639*	1640- 1649	1650- 1659	1660- 1669	1670- 1679	1680- 1689	1690- 1699
	N=1	N=8	N=19	N=27	N=33	N=44	N=54
LINENS							
Table cloth	1	3	7	19	16	20	21
Napkins	1	4	8	22	16	21	23
SILVER							
		1	3	4	12	11	15
EATING UTENSILS							
Spoon		1	8	15	18	21	32
Knife				1	3	1	4
Case of knives						2	3
VESSELS							
Dish		5	10	12	14	24	22
Bowl		1	1	6	3	7	6
Basin	1	1	5	9	9	15	20
Platter			2	1	1	3	3
Trencher			3	5	7	5	9
Plate		1	3	8	16	20	25
Saucer			2	6	4	3	3
Porringer		5	3	11	17	16	16
Salt cellar		2	6	8	11	14	21
Pepper box					2		5
Mustard pot						3	2
Butter dish/plate				2		1	3
Sugar dish			2				1
Chafing dish			2	13	6	11	8

*The single inventory for this decade is dated 1638.

Table 19. Mention in Estate Inventories of Table Linens, Silver, Eating Utensils, and Vessels for Food Service and Dining, Surry County Court Records, 1663-1699

	1663- 1669 N=4	1670- 1679 N=32	1680- 1689 N=32	1690- 1699 N=36
LINENS				
Table cloth	1	9	5	14
Napkins	1	11	8	13
SILVER				
	1	7	4	7
EATING UTENSILS				
Spoon	1	18	10	16
Knife	1	1	2	
Fork			2	
VESSELS				
Dish	3	15	10	15
Bowl		10	3	7
Berry bowl		1	2	
Basin	1	6	2	7
Trencher		5	2	3
Plate	1	5	9	10
Saucer		5	2	
Porringer	1	11	7	12
Salt celler		7	7	7
Chafing dish	1	2	5	5

Table 20. Mention in Estate Inventories of Vessels for Serving Beverages and for Drinking, York County Court Records, 1638-1699

	1630- 1639*	1640- 1649	1650- 1659	1660- 1669	1670- 1679	1680- 1689	1690- 1699
	N=1	N=8	N=19	N=27	N=33	N=44	N=54
Bottle			1	3	7	13	26
Case with bottles			2	5	4	3	3
Punch bowl						2	1
Pottle pot/bottle				1	3	2	4
Jug				3	6	4	8
Beaker		1		1	2	1	2
Flagon		1	4	8	8	4	12
Tankard			4	7	11	17	19
Drinking pot		1	5	8	13	9	17
Tumbler			1		1	3	6
Wine glass/bowl		1			1		1
Mug						1	7
Cup			2	5	5	6	11
Dram cup		2	4	5	7	6	4
Sack cup			1	3	3	1	1
Caudle cup				1	1	1	

*The single inventory for this decade is dated 1638.

Table 21. Mention in Estate Inventories of Vessels for Serving Beverages and for Drinking, Surry County Court Records, 1663-1699

	1663- 1669 N=4	1670- 1679 N=32	1680- 1689 N=32	1690- 1699 N=36
Bottle		7	12	15
Case with bottles	2	1	1	2
Flask			1	2
Jug		6	3	5
Beaker		2	3	1
Flagon		9	6	9
Tankard		10	8	6
Drinking pot	1	5	5	6
Mug				4
Cup		2	3	4
Dram cup	1	6	3	
Sack cup		2	1	
Caudle cup		1	2	

Table 22. Vessels and Utensils for Dining and Drinking
Infrequently Mentioned in Estate Inventories, County
Court Records

York County
(1638-1699)

VESSELS FOR FOOD

Fruit dish
Berry bowl
Cheese plate
"Scallop dishes"
Castor
Sugar box
Cistern

VESSELS FOR LIQUIDS

Pitcher
Posset pot
Syllabub pot
Gill

UTENSILS

Fork

Surry County
(1663-1699)

VESSELS FOR FOOD

Fruit dish
Mustard pot
Butter dish
Pepper box

VESSELS FOR LIQUIDS

Pottle pot
Wine glass/bowl
Sucking bottle
Gill
Punch cup
Tumbler

UTENSILS

Case of knives

Inventories consistently mention table cloths and napkins throughout the century, with many inventories including large quantities in various cotton and linen fabrics: diaper, dowlas, holland, calico, and damask. (Fabrics are defined in Appendix C, a Glossary.) Writers have sometimes contended incorrectly that seventeenth-century Americans did not use table cloths, that they covered their tables with turkey carpets. Carpets indeed graced tables, but not for dining; seventeenth-century paintings and drawings almost always show cloths on dining tables, as does Randle Holme;² carpets appearing in Dutch paintings of the period are either in still-lives or in parlor settings. Commodious napkins measuring from two and a half to three feet square were used to hold meat with the left hand while cutting it with the right.³

Wealthy families possessed substantial quantities of silver plate, acquiring it late in the century as an investment more permanent and easier to store than tobacco, the standard currency. People of more modest means had small amounts of silver—often one spoon, or one spoon and one cup. Settlers also valued pewter spoons, often possessing only one or two pewter spoons along with a dozen of the less costly latten alloy. The spoons in Plate 36 resemble today's soup spoons and serving spoons—seventeenth-century spoons were not

² Descriptions and illustrations attributed in this chapter to Randle Holme are from the 1905 edition of *The Academy of Armory*, Book III, Chapter 14.

³ See Jay Allan Anderson, "'A Solid Sufficiency': An Ethnography of Yeoman Foodways in Stuart England" (Diss. Univ. of Pennsylvania 1971), p. 237.



Plate 36. This collection of pewter and brass spoons found in James City County illustrates, from left to right, the evolution of spoon shapes during the colonial period. The three spoons on the right are from the eighteenth century. The fig-shaped bowl of the first spoon at the left typifies the bowl shape of the early seventeenth century; later spoons have egg-shaped bowls. The second, fourth, and fifth spoon handles have trifid terminals also characteristic of the seventeenth century. Photograph courtesy of Virginia Research Center for Archaeology.

dainty tea spoons or coffee spoons, but large, rather awkward utensils with shallow bowls.

Table knives, sometimes stored in cases (Figure 18), were small and slender through most of the century, with sharp points for spearing food. Only as forks came into general use did the knives lose their spearing tips and evolve into the larger, rounded blades characteristic of the eighteenth century (see Plates 14 and 23, Chapter 5). Even very late in the seventeenth century few Virginians owned or used forks; only three York and Surry County inventories mention forks not defined as cooking forks, and forks rarely appear in archaeological assemblages. Although the Jamestown artifact collection includes dining forks (see Plate 11, Chapter 5), those may be from later periods.

Although today a dish is most precisely a serving vessel, *dish* in the seventeenth century can denote a large family of vessels (like today's "set of dishes"). Randle Holme lists the kinds of seventeenth-century dishes with names "proportionable to [their] bignesse and use":

- A platter, if large.
- A dish, which [is] of a lesser sort.
- A midleing dish.
- A Broth dish, deeper bottomed than flesh dishes.
- A Bason, is almost halfe round in the concave, or belly; and narrow, or broad, or noe brime at all.
- A sallett dish.
- A Trencher plate, or plate.
- A sawcer. (p. 4)

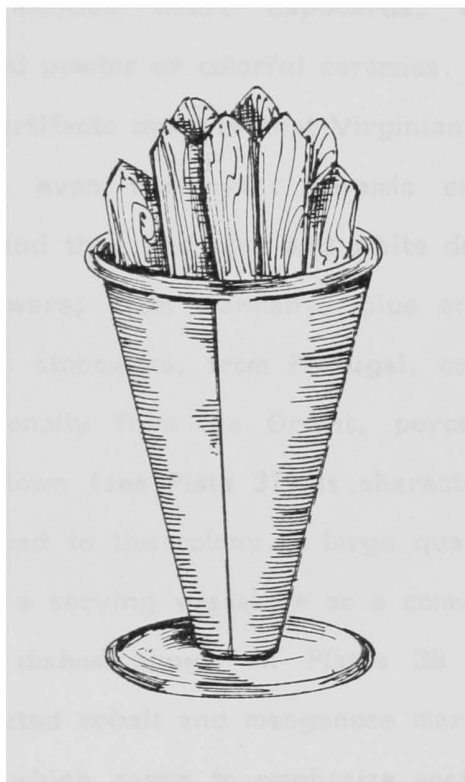

Figure 18. A knife case drawn from Randle Holme (illustration 12 facing p. 18).

Holme then defines the dish category of dishes as "both for necessary use (as, putting of meate into them) to serve up to tables; as also to adorne their countrey houses, and court cuberts . . ." (p. 4). Many estate inventories mention court cupboards, often adorned—one presumes—with prized pewter or colorful ceramics.

Archaeological artifacts indicate that Virginians possessed a great variety of colorful, even flamboyant ceramic eating and drinking vessels. From England they had blue and white delftware, yellow and brown sgraffito slipware; from Germany, blue and gray salt-glazed stoneware and brown stoneware; from Portugal, cobalt and manganese majolica; and occasionally from the Orient, porcelain.⁴ A sgraffito dish found at Jamestown (see Plate 37) is characteristic of the North Devon slipware shipped to the colony in large quantities; it may have been used either as a serving vessel or as a communal eating vessel. Finer, less coarse dishes appear in Plates 38 and 39; especially interesting is the fluted cobalt and manganese marbled tin-glazed dish in Plate 39, a dish which seems to emphasize aesthetic pleasure over

⁴ For descriptions and illustrations of seventeenth-century ceramics, see Ivor Noel Hume, *Early English Delftware from London and Virginia*, Colonial Williamsburg Occasional Papers in Archaeology, Vol. II (Williamsburg: Colonial Williamsburg Foundation, 1977); C. Malcolm Watkins, "North Devon Pottery and its Export to America in the 17th Century," *United States National Museum Bulletin* 225, Contributions from the Museum of History and Technology, Paper 15 (Washington: Smithsonian Institution, 1960), pp. 17-59. Also see C. Malcolm Watkins, "Ceramics in the Seventeenth-Century English Colonies," in *Arts of the Anglo-American Community in the Seventeenth Century*, ed. Ian M. G. Quimby, Winterthur Conference Report, 1974 (Charlottesville: Univ. Press of Virginia, 1975), pp. 275-99.



Plate 37. Yellow and brown sgraffito dish found at Jamestown, probably made in North Devon, England, c. 1640-1680. Diameter 30.5 cm. Photographed courtesy National Colonial Historical Park, National Park Service, Jamestown; J-7365.

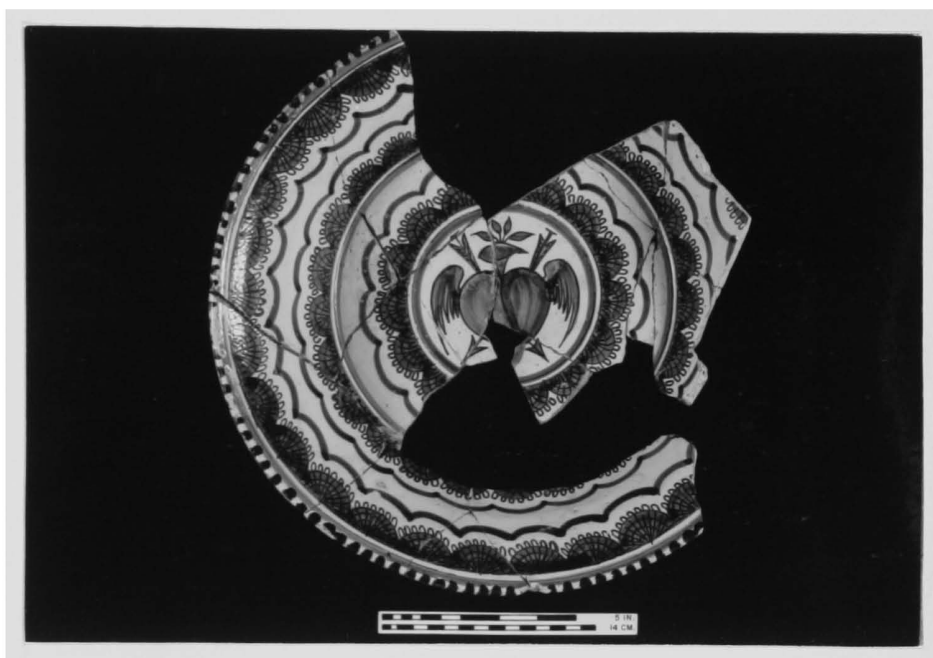

Plate 38. Portuguese majolica straight-sided dish with manganese glaze, found at the Petitt site in James City County in an archaeological context of 1690-1710. The winged-heart pierced with arrows symbolizes love and charity. Diameter 36 cm. Photograph courtesy of Virginia Research Center for Archaeology; GL A1, A2, A3.



Plate 39. Marbelized cobalt blue and manganese purple tin-enameled earthenware fluted dish, possibly German or Dutch, found at Pettus site in James City County. Archaeological context, second half of seventeenth century; length 19 cm, base diameter 10.5 cm. Photograph courtesy of Virginia Research Center for Archaeology; KM 50, 69A.

utilitarian function and to belie the rough frontier setting in which it was used. Similarly shaped fluted dishes often appear in seventeenth-century Dutch paintings, usually as a background or container for whole fresh fruit. Although the Dutch still-life paintings were not painted from life but composed from drawings of vessels and of foods, the Terborch painting in Plate 40 shows a woman peeling an apple—a practical, humble activity—while additional apples repose in a fluted dish shaped like the Virginia artifact.

Many inventories, even late in the century, list as many as two dozen wooden trenchers and occasionally mention wooden plates and painted wooden plates. During the Middle Ages trenchers were slices of heavy bread placed directly on the table and used as a base for soupy foods spooned from a communal dish. Wood later replaced bread, but wooden trenchers retained the shape of the oblong slices of bread and generally served as a vessel for two diners, the custom of dinner partners going back to when two people shared a trencher.

Whereas platters were for serving or communal dining, individual diners used plates. A Portugese majolica plate shown in Plate 41, typifying the exuberant design and color found in many seventeenth-century ceramics, has a cobalt blue and manganese purple glaze and features a rabbit in the center design; English delftware (like majolica, tin-glazed) sometimes has red and green motifs with a similar exuberance, as well as the more common blue and white designs.



Plate 40. Detail from "Woman Peeling an Apple" (c. 1661-1662), by Gerard Terborch, showing apples in a fluted dish similar to artifacts found in Virginia. Painting illustrated in Leonard J. Slatkes, *Vermeer and His Contemporaries* (New York: Abbeville Press, 1981), p. 115.



Plate 41. Portugese majolica plate with cobalt and manganese glaze, found at Petitt site in James City County in an archaeological context of 1690-1710. Diameter 22 cm. Photograph courtesy of Virginia Research Center for Archaeology; GL A1, A2, A3.

The porringer, whether pewter or earthenware, appears in both inventories and artifact assemblages and figured on seventeenth-century tables as the most popular bowl for individual eating. Shallow round vessels for porridge, soup, or potage, the pewter porringer characteristically has a pierced, flat, ear-like handle. Many earthen porringers imitate the shape and handle of the pewter vessels, but others depart from the pewter model and have deeper bodies and small loop handles (see Plate 42). Poringers sometimes have two handles, as explained by Randle Holme: "A two eared pottinger . . . is an half round vessell in the belly without a brime, some haveing two eares, but most onely one eare or handle or stouke as the countrey terme is, by which it is carryed from place to place. . . ." (pp. 4-5).⁵

Other small or individual bowls appear in both artifact assemblages and inventories. Plate 43 shows two small Delftware bowls found at Jamestown; although the unpainted vessel on the right is probably most properly classified as a bowl, the blue and purple one on the left might be called a saucer. Small deep plates or shallow bowls, seventeenth-century saucers (sauce-ers) were used for serving sauces and condiments. The most important condiment dish on the seventeenth-century dining table was the salt, or salt cellar. Pewter or silver salts appear frequently in probate inventories; ceramic,

⁵ Poringers sometimes were used as bleeding bowls, but Noel Hume points out that they should be called bleeding bowls only if graduated on the inside to measure the blood extracted; see Noel Hume, *Early English Delftware*, p. 89n.



Plate 42. Earthenware porringer and drinking cup found at Jamestown; diameter of each, 12.5 cm. Photographed courtesy of National Colonial Historical Park, National Park Service, Jamestown; J-7332, J-7333.

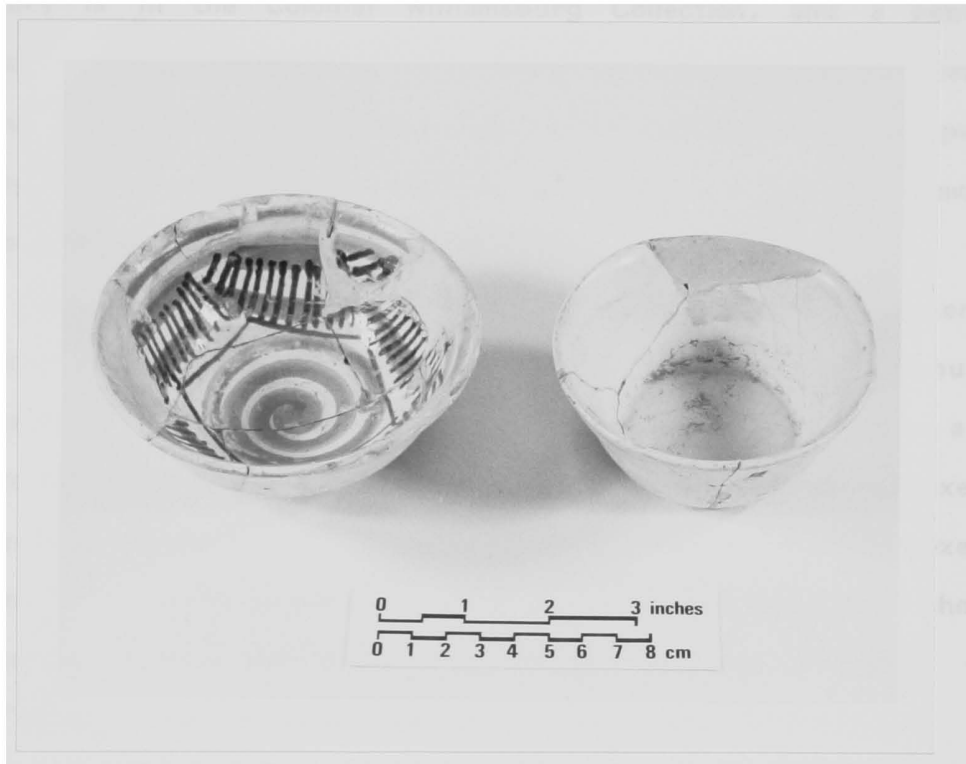

Plate 43. Saucer and small bowl found at Jamestown. The saucer (or bowl) on the left is tin-glazed earthenware with blue and purple decoration, probably Lambeth delftware, early to mid seventeenth century; diameter 12 cm, height 2.5 cm. The bowl on the right is probably Bristol delftware from the second half of the seventeenth century; diameter 10 cm, height 3.5 cm. Photographed courtesy of National Colonial Historical Park, National Park Service, Jamestown; J-7499, J-7490.

among archaeological artifacts. Randle Holme illustrates a covered salt cellar (Figure 19), but many salts were open vessels with feet or pedestals; a plain white ceramic standing salt from the seventeenth century is in the Colonial Williamsburg Collection, and a pewter standing salt appears in a seventeenth-century painting by Pieter Claesz.⁶ Flat saucer-like delftware salts, hexazonal or square, appear among Virginia artifacts and—because less costly—may have been more common than pewter and silver salts.⁷

Other condiment dishes included castors (perforated shakers) ordered from England by wealthy planters; in 1689 William Fitzhugh requested "a Sett of Castors that is to say for Sugar, Pepper and Mustard."⁸ Inventories also mention pepper boxes and sugar boxes, as well as mustard pots. Figure 20 shows two castors, or boxes, drawn from Randle Holme, and Holme's description warns that these shakers were used also in cooking, not necessarily at the table. Of the "*silver duster, or peper box*" illustrated on the right he says,

If a nut [a perforated cocus nut, as shown in Figure 19] cannot be had cookes can make shift, with a round tin box with holes on the top, to dust their rost meates; if this be wanting they can flower it with their hand, but the better sort of people have these boxes made of richer mettles." (p. 4)

⁶ See Nole Hume, *Early English Delftware*, p. 29, plate 16; B. Haak, *Art Treasures of the Rijksmuseum, Amsterdam* (New York: Harry N. Abrams, 1966), plate 40.

⁷ A hexagonal salt is shown in Noel Hume, *Early English Delftware*, plate 24 facing p. 36.

⁸ *William Fitzhugh and His Chesapeake World 1676-1701*, ed. Richard Beale Davis (Chapel Hill: Univ. of North Carolina Press, 1963), p. 258.

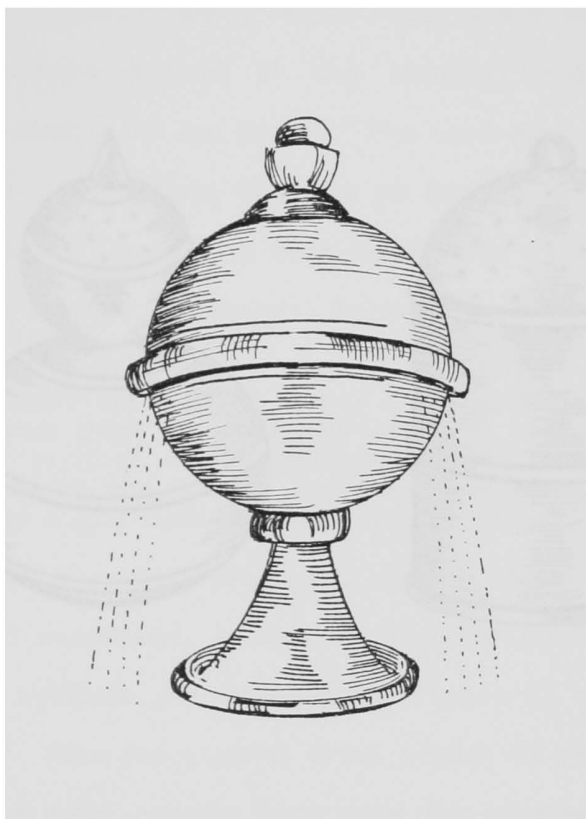

Figure 19. Covered salt cellar drawn from Randle Holme (illustration 1 facing p. 18).

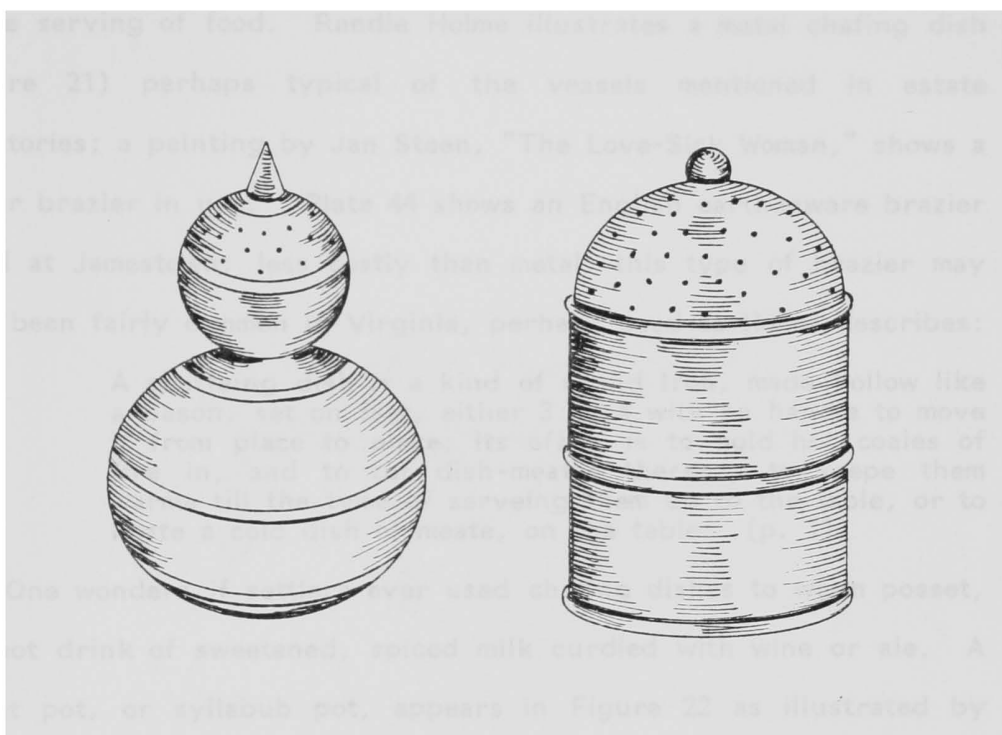

Figure 20. Dusters drawn from Randle Holme (illustrations 14 and 15 facing p. 18). Holme describes the duster on the left as a "doubel cocus nut" for flour, pepper, or sugar, called variously a "*shell duster*, or *peper box*; or *sugar box*." He terms the duster on the right "a *silver duster*, or *peper box*" (pp. 3, 4).

Receptacles holding hot coals for warming food away from the fireplace, chafing dishes or braziers appear in both probate inventories and artifact assemblages and suggest a refinement or care in the serving of food. Randle Holme illustrates a metal chafing dish (Figure 21) perhaps typical of the vessels mentioned in estate inventories; a painting by Jan Steen, "The Love-Sick Woman," shows a similar brazier in use.⁹ Plate 44 shows an English earthenware brazier found at Jamestown; less costly than metal, this type of brazier may have been fairly common in Virginia, perhaps used as Holme describes:

A chaffeing dish is a kind of round Iron, made hollow like a Bason, set on feet, either 3 or 4 with an handle to move it from place to place; its office is to hold hot coales of fire in, and to set dish-meates thereon, to keepe them warme till the tyme of serveing them up to the table, or to heate a cold dish of meate, on the table. (p. 11)

One wonders if settlers ever used chafing dishes to warm posset, the hot drink of sweetened, spiced milk curdled with wine or ale. A posset pot, or syllabub pot, appears in Figure 22 as illustrated by Randle Holme.¹⁰ Also for a warm drink similar to posset (with gruel usually replacing milk), caudle cups were two-handled drinking bowls with covers; museum catalogs sometimes identify similar bowls without covers as posset pots.

⁹ See Caroline Bugler, *Dutch Painting in the Seventeenth Century* (New York: Mayflower Books, 1979), p. 41.

¹⁰ A similar pot with smaller handles, made in England c. 1635-1645, is illustrated in Noel Hume, *Early English Delftware*, p. 18, plate 8.

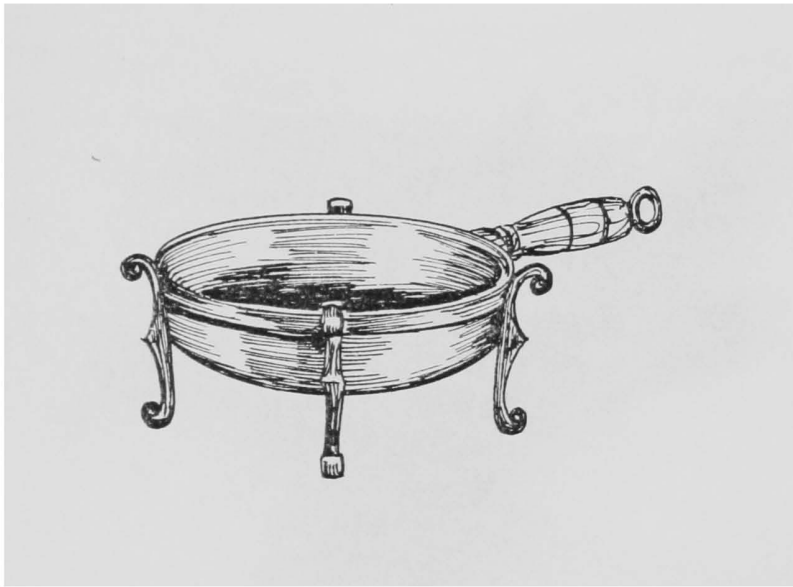

Figure 21. A chafing dish drawn from Randle Holme (illustration 53 facing p. 18).



Plate 44. Earthenware brazier found at Jamestown, probably made in England c. 1625. Diameter 20 cm, height 9 cm. Photographed courtesy of National Colonial Historical Park, National Park Service, Jamestown; J-7870.



Figure 22. "A possett pott, or a wassell cup, or a sillibube cup"
drawn from Randle Holme (illustration 44 facing p. 18).

Posset, syllabub, and caudle may have been occasional drinks for Virginians, warming potions to sooth or "coddle" ailing persons. Cider and beer, on the other hand, were everyday drinks, milk was generally available, and wine and spirits were favored by those who could either make or buy them. For these everyday beverages, settlers had a great variety of bottles, jugs, and cups. Cider, beer, and wine were generally stored in casks and transferred into bottles only for serving. Large quantities of broken wine bottle glass have been found by archaeologists in Virginia, and in addition to the vague listing of "bottles" in inventories, "cases with bottles" appear in the listings. Case bottles are square, somewhat fragile bottles transported, sold, and stored in protective boxes or cases.

An easily identifiable bottle appears often among artifacts: the Bellarmine bottle, a bulbous vessel ranging from small to large, of Rhenish salt-glazed stoneware with a brown mottled surface, narrow neck, embossed medallions, and—opposite its handle—a bearded human or semi-human face (see Plate 45). These non-porous stoneware bottles appear in Dutch paintings in a context suggesting their use for beer, wine, or other spirits.¹¹ Also mentioned in probate inventories and used for serving beverages, flagons were bottles which usually had a lid and sometimes had a handle and spout.

¹¹ See, for example, a still life by Pieter Claesz in Bugler, *Dutch Painting*, p. 77.

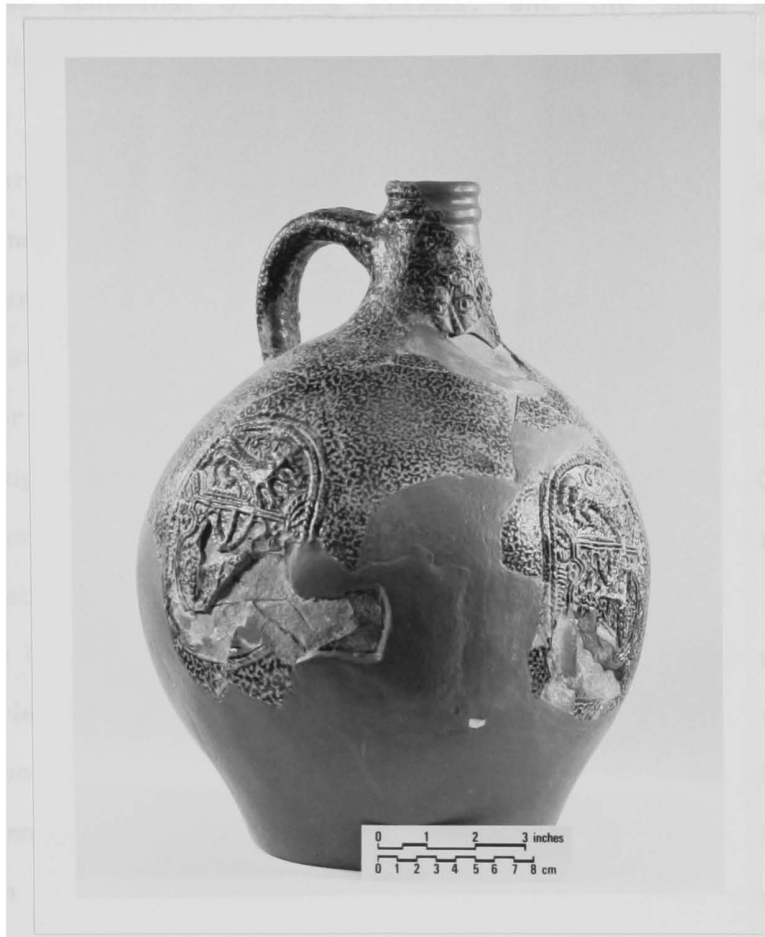

Plate 45. Bellarmine bottle found at Jamestown. The date 1661 appears on three medallions around the body. Height 37 cm. Photographed courtesy of National Colonial Historical Park, National Park Service, Jamestown; J-7538.

Jugs ranged in size from large to moderately small, with the large used in the dairy and for serving beverages, the medium used for serving or as communal drinking vessels, and the small used as individual drinking vessels. The jugs shown in Plate 46 have the characteristic bulbous body and narrow cylindrical neck; these are yellow and brown sgraffito slipware made in North Devon, England, but also common among Virginia artifacts are similarly shaped blue and grey salt-glazed stoneware jugs from Germany (a blue and grey jug is shown in Plate 18, Chapter 5). Pitchers rarely figure in either inventories or artifact assemblages; Plate 47 shows a coarse earthen pitcher or jug found at the Pasbehay site in James City County. Since coarsewares predominate among ceramics found at Pasbehay, this pitcher probably was used there for serving beverages; in a more affluent home it likely would be relegated to kitchen and dairy uses.

Inventories frequently mention pewter drinking pots of varying sizes (from one pint to 2 quarts, or a pottle). Like jugs, drinking pots were communal or serving vessels when large, individual drinking vessels when small. A pewter drinking vessel which might be classified as a pot appears in a painting shown in Plate 5 (Chapter 5). Other drinking vessels—generally of pewter when mentioned in estate inventories—included tankards, tall one-handled vessels usually with a lid; beakers, shallow open cups or goblets much like wine tasters; and tumblers, cups without a handle and originally with a rounded bottom so they could not be set down until emptied. Mugs were straight-



Plate 46. Yellow and brown sgraffito jugs found at Jamestown, probably made in North Devon, England. Heights 19 cm, 16 cm, 16 cm (left to right). Photographed courtesy of National Colonial Historical Park, National Park Service, Jamestown; J-7345, J-7347, J-7346.



Plate 47. Coarse earthen jug or pitcher found at Pasbehay site in James City County. Locally made; archaeological context 1630-1650. Photograph courtesy of Virginia Research Center for Archaeology; GL 114, 114A, 168A.

sided vessels with a handle, taller than wide; they could range in size from four ounces to more than two quarts. Cups, however, were small vessels which held less than a pint (see Plate 48). Smallest of all was the dram cup, usually of silver or pewter, for small portions (drams) of spirits. The wine bowls mentioned in inventories are probably shallow cups of pewter or silver, whereas the wine glasses are similar to ones used today, with cone-shaped instead of rounded bowls. The feet, or pedestals, of wine glasses survive most conspicuously among wine glass fragments in archaeological assemblages; Plate 49 shows glasses reconstructed from fragments found at Jamestown. Among this diverse miscellany of drinking vessels, the seventeenth century even had its counterpart to the modern vacuum bottle: the flask or costrel, a small bottle with carrying handle or loops, carried by travelers and field workers.¹² Inventories sometimes list flasks or flaskets, and Figure 23 shows a costrel, or double-handled earthenware bottle found at Jamestown. Similar bottles sometimes had small ears instead of handles, for a carrying cord or leather strap. Such a bottle is shown cooling in the water beside a boat in Bosch's "Ship of Fools."¹³

¹² A covered jug with a cord is fastened, along with a spoon, to a pilgrim's belt in a 1564 drawing by Bruegel. See Ludwig Munz, *Bruegel: The Drawings* (London: Phaidon, 1961), plate 99.

¹³ See Timothy Foote and the Editors of Time-Life Books, *The World of Bruegel c. 1525-1569* (New York: Time-Life Books, 1968), p. 57.



Plate 48. Yellow and brown sgraffito drinking cups found at Jamestown, probably made in North Devon, England. Height 7 cm. Photographed courtesy of National Colonial Historical Park, National Park Service, Jamestown; J-254, J-7534, J-7297.



Plate 49. Wine glasses perhaps made in England or Venice c. 1670, reconstructed from fragments found at Jamestown. Smoky grey color, heights 10 cm and 11 cm. Photographed courtesy of National Colonial Historical Park, National Park Service, Jamestown; J-12115, J-12206.



Figure 23. Two-handled earthenware bottle found at Jamestown, probably from Spain or Portugal. Artifact date, before 1650; height 22 cm. Drawn from Watkins, "Ceramics in the Seventeenth-Century English Colonies," p. 286, figure 6.

Evidence of estate inventories and archaeological finds suggests that the average Virginia household possessed a limited collection of vessels and utensils for eating and drinking: large dishes, trenchers or plates, porringers, drinking jugs or pots, spoons, and knives. Settlers prized salt cellars, and sometimes used chafing dishes to warm food at the table. Although the size of artifacts and of vessels listed in probate inventories suggests a shift during the century from communal to individual eating, documentary sources do not mention or describe such a shift. In fact, documentary sources provide little information about eating customs apart from travelers' accounts describing the settler's hospitality and fondness for revelry.

Taverns or ordinaries were active at Jamestown and, later in the century, at ferry landings, but the expense of public accommodations and their unavailability in less populated areas encouraged travelers to lodge instead at private homes.¹⁴ The Swiss traveler Michel writes, "At first we were too modest to go into the houses to ask for food and lodging, which the people often recognized, and they admonished us not to be bashful, as this was the custom of rich and poor."¹⁵ Regardless of their degree of wealth, Virginians freely extended both food and lodging to visitors, even instructing servants to accommodate

¹⁴ *The Reverend John Clayton, A Parson with a Scientific Mind*, ed. Edmund Berkeley and Dorothy Smith Berkeley (Charlottesville: Univ. of Virginia Press, 1965), p. 4.

¹⁵ "Report of the Journey of Francis Louis Michel from Berne, Switzerland, to Virginia, October 2, 1701–December 1, 1702," trans. and ed. Williams J. Hinke, *Virginia Magazine of History and Biography*, 24 (1916), 116.

visitors when the master was absent from home. Although some travelers slept on cold floors and ate poor food at rough frontier homes, Michel writes that he often found better food with poor people than with the rich.¹⁶

Describing a harvest festival dinner, Michel gives one of the rare accounts of a celebratory meal:

The custom of the country, when the harvest is to be gathered in, is to prepare a dinner, to which the neighbors are invited, and for which two men have sufficient work to do. There are often from thirty to fifty persons cutting grain, so that frequently they have work for only two hours.

This is one of the principal festivals or times of rejoicing. . . . Fresh meat cannot be kept in summer longer than twenty-four hours, hence [when rain prevented a wheat harvest which was to have been followed by a dinner] the good people were compelled, if they did not want to let the sheep and chicken, which they had prepared, spoil, to entertain us, which lasted for a day and a half.¹⁷

Because Virginians had so little opportunity for sociable relaxation and entertainment, they turned the few occasions for gathering with friends into unrestrained celebrations generally characterized by much drinking and by firing rounds of shot. With funerals providing reason for convivial gatherings, some conservative settlers tried to forestall excesses by dictating limits for funeral spirits and shot in their wills. Court records also include accounts of funeral expenses: in 1679 John Griggs's estate in York County was charged, in addition to the cost of his funeral sermon and a coffin,

¹⁶ "Journey of Francis Louis Michel," p. 140.

¹⁷ "Journey of Francis Louis Michel," p. 32.

for a beef, two turkeys, two geese, one hog, two bushels of flour, dunghill fowl, twenty pounds of butter, sugar and spice, six gallons of cider, and six gallons of rum—plus the cost of "dressing the dinner," an interesting charge that suggests some sort of seventeenth-century catering service. Because wedding expenses were not charged to an estate, they were unlikely to be recorded in county records, but the visitor Durand tells of a wedding with at least a hundred guests.

Although it was November, we ate under the trees. The day was perfect. We were twenty-four at the first table. They served us so copiously with meats of all kinds that I am sure there would have been enough for a regiment of five hundred soldiers. . . . The Indians [colonists] eat almost no bread, seldom drink during meals: but they did nothing afterwards, for the rest of the day & all night, but drink, smoke, sing & dance. They had no wine; they drank beer, cider, & punch, a mixture prepared in a large bowl. . . . It is the custom to take only one meal upon such occasions, at two o'clock in the afternoon.¹⁸

Michel writes of another dinner at two o'clock, apparently the fashionable dining hour late in the century. Although writers mention breakfast and supper, they do not describe those meals or specify the foods served. Beverley writes at the turn of the century that "The Gentry pretend to have their Victuals drest, and serv'd up as nicely, as at the best Tables in *London*."¹⁹ Perhaps all Virginians, whether wealthy or not, followed meal patterns and customs similar to those in

¹⁸ *A Huguenot Exile in Virginia*, ed. Gilbert Chinard (The Hague, 1687; rpt. New York: Press of the Pioneers, 1934), pp. 137-38.

¹⁹ Robert Beverley, *The History and Present State of Virginia*, ed. Louis B. Wright (Chapel Hill: Univ. of North Carolina Press, 1947), p. 291.

England.

The travelers Durand and Michel remark on the display and unrestrained indulgence of the wealthy planters, not on elegance or artistry. Even when a small group of wealthy planters built a "banqueting house" in 1670 and agreed to rotate among themselves in giving feasts, their purpose was perpetuating boundary lines, not dining.²⁰

Romantic antiquarians often invest the daily life of past times with a refinement it never possessed, interpreting lavish display as artistry. Even when wealth permitted silver plate and imported liquors, dining was probably haphazard just as domestic life in general had a disorderly character in both rich and poor households. On small plantations (farms) without domestic servants, daily activities likely focused on growing tobacco and on maintaining a self-sufficient food supply, with meal times as well as meal composition determined by necessity and opportunity, not by design.

²⁰ See extracts from Westmoreland County court records in *Virginia Magazine of History and Biography*, 8 (Oct. 1900), 171-72.

Section III. CONCLUSIONS

Chapter 8

THE CUISINE

Physical possibilities and limitations determined the basic components of seventeenth-century Virginia's cuisine; cultural heritage determined its style. Although documentary records and artifacts reveal much about the physical factors in Virginia's cuisine—the available foods and the physical equipment related to food preparation and dining—available research sources reveal little about style, little about the processes, activities, and values associated with the cuisine. English settlers living in seventeenth-century Virginia apparently practiced the same culinary traditions and meal patterns as English people living in England, with one dramatic exception: the Virginians' acceptance of Indian corn as their staple food. Echoing the frontier setting, Virginia's cuisine was rough and rudimentary, lacking technical complexity and aesthetic refinement; gregarious hospitality emphasized display and entertainment, not subtle appreciation.

Many demographic and social influences discouraged a complex or inventive cuisine in Virginia: the unbalanced sex ratio which obliged many men to live alone or in all-male households; the high mortality which eroded family stability; the labor shortage; the initial servant status of most of the population; the lack of generational continuity in a society which failed until the end of the century to reproduce itself through child-bearing instead of immigration; the lack of communication

among a scattered and isolated populace; the unstable government and neglect of religion and education.

The English country yeomen who settled Virginia brought with them a sturdy tradition of domestic self-sufficiency and a meal pattern which emphasized grains, bread, dairy products, beer, and cider. Whereas meat was an occasional luxury in England, Virginians enjoyed an abundance of pork, poultry, and game; cattle provided both dairy products and beef. Instead of porridge made with barley or oats, colonists prepared hominy—porridge made with Indian corn. Instead of maslin or rye bread, Virginians made corn pone, the simple Indian bread. Adhering to English habits, they made stews and boiled dinners, baked fruit tarts and meat pies, used herbs and vegetables as both pot vegetables (boiled with meats) and sallets (cooked and dressed with oil and vinegar). Settlers in Virginia liked puddings and custards, kept bees as a source of honey, and purchased sugar and molasses from the Caribbean.

Households produced their own butter and cheese (sometimes with surplus to sell), made cider and beer, and often milled grains at home. The limited evidence of food handling practices and skills indicates seventeenth-century Virginians concentrated food-related labors on food production and preservation, not on cooking. They devoted whatever labor could be spared from tobacco growing to feeding, not to dining—to growing corn, to pounding hominy, to milking cows, to pressing cider, to butchering and salting meat, to pickling seafood.

Only in those macro processes of dairying, brewing, salting, and pickling did Virginians transform foods or change their basic properties. Puddings, pies, and custards are the most complex daily preparations suggested by equipment listed in estate inventories; documentary sources mention fruit tarts and wheat bread but provide no clues to how they were made. Except for watermelons and perhaps other fruits, Virginians apparently cooked fruits and vegetables in accordance with English custom, often drying berries and other fruits for use "like currants." Fruits were probably cooked to a pulp. Sources give no hint of the texture of cooked vegetables, but they do mention vegetables cooked simply, dressed with butter and cream. Uncomplicated meat and seafood preparations predominated: spit-roasted meats and poultry, fried fish, raw oysters. In general, fresh foods were cooked in simple and straightforward styles, whereas preserved foods were more often cooked in combinations (salted meat with dried corn or beans) which accommodated intensified flavors and softened firm textures.

Virginians apparently liked salty, sweet, and acidic flavors. Settlers added spices to puddings and cooked fruit, but no evidence suggests that they used spices with meat in the medieval tradition—although the use of herbs for sallet greens followed the medieval pattern. Within the context of basic foods simply prepared and processed, Virginians neither elaborately transformed nor subtly enhanced those foods. Their hospitality and dining followed the same pattern: hearty abundance with little refinement.

The English have long regarded dining as a social rather than aesthetic or gastronomic experience, and the early colonial predilection for carousing reflected a cultural tradition as well as pleasure in temporary relief from isolation and grinding labor. A harsh frontier environment without leisure or art does not foster elegance and epicureanism, even among the wealthy.

Although this study has not uncovered or painted a complete portrait of seventeenth-century Virginia's cuisine, it has drawn a sketch, an outline which reveals a rudimentary food pattern in keeping with the colony's rough frontier setting. New and important information on the physical equipment for food preparation, identification of available foods, and confirmation of the continuing English tradition give the cuisine's portrait an underlying definition or structure. Insights into labor available for food-related activities and into the disorder of daily life begin to contour and model the face of the cuisine, but ignorance of the techniques and methods for preparing food robs the portrait of detail and color. Most disappointing of all, a dearth of information about the customs and values relating to food leaves the face without expression, without a clear personality.

Additional studies can add to the portrait and better focus the information already uncovered. We need greater knowledge and understanding of the seventeenth-century English yeoman cuisine which accompanied the settlers to Virginia, and a greater knowledge of

their food preparation methods—of the ways foods were changed and transformed in cooking, the proportions of ingredients combined in dishes, and the length of time foods were cooked. We need more information on the values and standards applied to food, on the differences in food habits among generations and classes. Studies could also address the properties of seventeenth-century plants and animals used for food. Just as seventeenth-century bread, beer, and cheese differ from products common today, fruits and vegetables grown three hundred years ago differ greatly from ones grown today, and livestock was raised then under different conditions.

In a search for greater knowledge of food in seventeenth-century Virginia, more extensive and intensive study of county court records might reveal much about food habits in relation to cultural patterns. Because the records are so difficult to read, information apart from probate inventories likely will remain hidden until more court records are accurately transcribed or until researchers can spend large amounts of time on small amounts of records. The inventories themselves offer many possibilities for analysis: the relation of food-related possessions to status and wealth, and study of the "kitchen package" or total kitchen equipage within individual households. Archaeological studies now address the pattern and style of daily life at individual domestic sites, and those findings may contribute new insights into food patterns and styles.

Most interesting and most challenging of all research possibilities are re-creative studies which duplicate the seventeenth-century cuisine by reproducing the foods, equipment, conditions, techniques, and customs so that we can in some measure experience the cuisine firsthand. Growing old varieties of Indian corn, pounding dried corn into hominy and meal, stewing hominy with salted meat, and baking bread in a replica of the Jamestown oven would provide opportunity to study both the process of feeding and the sensory experience of eating in seventeenth-century Virginia.

Chapter 9
THE PROVEN PUDDING:
AN EVALUATION OF THE METHOD

The label "a method for studying historical cuisines" is broad and general, as is this study. The research procedure outlined in Chapter 2 served its purpose; it brought forth a definition and description of seventeenth-century Virginia's cuisine. Yet this method might more properly be termed a method for the descriptive history of a cuisine, the first but not final phase in studying historical cuisines. Two additional phases await further development: interpretive studies and re-creative studies. Carrying historical research on a cuisine through these additional stages can enrich, clarify, and strengthen the descriptive base, making the cuisine's definition more three-dimensional and giving a more realistic and accurate sense of the experience of eating in earlier times.

Using artifacts, documents, and iconographic records as three mutually dependent research sources evoked the study's richest and most convincing findings: identification of cooking and dining equipage. Although historical archaeologists and other scholars routinely employ these three types of sources, historical cuisines have rarely been studied from this tripartite base. The research procedure outlined in the method also served the study well, with five stages defined as:

- 1) development of a framework of research questions,
- 2) identification of historical sources,
- 3) data collection and evaluation,
- 4) analysis and synthesis of research data, and
- 5) presentation of results and conclusions: the definition and description of a cuisine within its historical context.

The framework of research questions proved useful and comprehensive, focusing and directing research activities through the study's progressive stages. Common to research in general and obvious to seasoned scholars, the other steps outlined in the method—data identification, collection, analysis, and synthesis—require adaptation and innovation according to the nature of available sources and the kinds of data uncovered. The framework of research questions, however, is specific to cuisines and thus the method's most important contribution, probably needing little adaptation for application to a wide variety of cultures.

The greatest challenge in the framework of questions is its comprehensiveness: the information encompassed within a study able to answer all the questions would be overwhelmingly voluminous. Because of limited research sources, many questions remain unanswered when addressed to seventeenth-century Virginia's cuisine; only the obstinate obscurity of that cuisine makes its comprehensive study possible as a manageable single study. Much more practical would be studies of portions or aspects of a cuisine or studies of

shorter time periods. Suitable topics for concentrated study include available foods, cooking equipage, dining customs, food preparation methods, and beliefs and values related to food. Studies could also focus on specific foods (fruit, seafood) or on activities (dairying, brewing, food preservation).

The need for both comprehensiveness and detail presents something of a chicken-and-egg dilemma: whether first to study the total cuisine or first to study specific aspects of the cuisine. Most effective perhaps is an initial general overview to put the cuisine and its culture in context, then a detailed study of the cuisine's components, and finally a comprehensive relation of the components to each other and to the culture. Until scholars collect a body of knowledge about historical cuisines in particular as well as in general, much research needs to concentrate on collecting and cataloging data in straightforward descriptive histories. As that descriptive base develops, researchers can proceed to the interesting realm of interpretive historical studies.

Interpretive studies begin to ask "why" and "how" as well as "what," to look for relationships between a cuisine and its culture, to show how factors in the historical context influence a cuisine, to identify longitudinal patterns linking past with present food patterns. Because increased understanding of seventeenth-century Virginia's demographic factors shatters stereotypical assumptions about both cuisine and culture, I found most interesting of all the insights

developed in this study those which related social history to food habits. Information gathered in the descriptive history of a cuisine provides most of the data required for interpretive studies, with innovative analysis and synthesis transforming description into interpretation.

Unlike interpretive studies, re-creative studies of a cuisine cannot spring directly from descriptive food histories. Requiring a more technical and hypothetical approach, re-creative studies address the question posed at the very beginning of this study and left unanswered at its end: what was it like to dine in another age? Descriptive studies of cuisines can give an idea, but not the experience, of eating a meal of the past. Only duplication of historical foods can answer—albeit hypothetically—questions about aesthetic and sensory qualities: appearance, aroma, flavor, and texture.

Hypothetical reproduction of historical foods parallels in many ways the hypothetical reproduction of historical musical and theatrical performances. Musicologists bent on reproducing a musical performance by Mozart, for instance, begin with the physical components: an eighteenth-century piano tuned to eighteenth-century pitch and placed in an eighteenth-century salon. Then re-creative musicians add the more elusive components of performing practice and style, attempting to re-create the experience of listening to Mozart. Historical foods might also be re-created by reproducing physical

components (foods and equipment) and performance practices (cooking methods), coping as skillfully as possible with the absence of the original performer (cook). Reproducing past cuisines within a scholarly and scientific framework can both unfold new knowledge about historic foods and evoke the aesthetic and sensory experience of dining in history.

SELECTED BIBLIOGRAPHY

A. METHOD

- Altick, Richard D. *The Art of Literary Research*. Rev. ed. New York: W. W. Norton, 1963.
- Anderson, Jay Allen. "'A Solid Sufficiency': An Ethnography of Yeoman Foodways in Stuart England." Diss. Univ. of Pennsylvania 1971.
- Bailey, Kent P., and Ransom B. True. *A Guide to Seventeenth-Century Virginia Court Handwriting*. Research Bulletin I. Richmond: Association for the Preservation of Virginia Antiquities, 1980.
- Barzun, Jacques, and Henry F. Graff. *The Modern Researcher*. New York: Harcourt, Brace, 1957.
- Bonnet, Jean-Claude. "The Culinary System in the *Encyclopedie*." In *Food and Drink in History: Selections from the Annales Economies, Societes, Civilisations*. Vol 5. Ed. Robert Forster and Orest Ranum. Trans. Elborg Forster and Patricia M. Ranum. Baltimore: Johns Hopkins Univ. Press, 1979, pp. 139-65.
- Carr, Lois Green, and Russell R. Menard. "Immigration and Opportunity: The Freedman in Early Colonial Maryland." In *The Chesapeake in the Seventeenth Century: Essays on Anglo-American Society*. Ed. Thad W. Tate and David L. Ammerman. New York: W. W. Norton, 1979.
- Carson, Jane. *Colonial Virginia Cookery*. Williamsburg: Colonial Williamsburg, 1968.
- Chang, K. C., ed. *Food in Chinese Culture: Anthropological and Historical Perspectives*. New Haven and London: Yale Univ. Press, 1977.
- Chace, Paul G. "Ceramics in Plymouth Colony, An Analysis of Estate Inventories 1631-1675." *Occasional Papers in Old Colony Studies*, No. 3 (Dec. 1972), 1-12.
- Committee on Food Habits. "Manual for the Study of Food Habits." *National Research Council Bulletin 111*. Washington: National Research Council, National Academy of Sciences, 1945.

- Cummings, Richard Osborn. *The American and His Food: A History of Food Habits in the United States*. Rev. ed. 1941; rpt. New York: Arno Press, 1970.
- Drummond, J. C., and Anne Wilbraham. *The Englishman's Food: A History of Five Centuries of English Diet*. Rev. Dorothy Hollingsworth. London: Jonathan Cape, 1957.
- Fleming, E. McClung. "Artifact Study: A Proposed Model." In *Winterthur Portfolio* 9. Ed. Ian M. G. Quimby. Charlottesville: Univ. Press of Virginia, 1974, pp. 153-73.
- Harper, Laura Jane. "A Possible Framework for Studying Food in Culture." Unpublished paper. Virginia Polytechnic Institute and State University, 1980.
- Horn, Walter, and Ernest Born. *The Plan of St. Gall: A Study of the Architecture and Economy of, and Life in a Paradigmatic Carolingian Monastery*. 3 vols. Berkeley: Univ. of California Press, 1979.
- Jelliffe, Derrick B. "Parallel Food Classifications in Developing and Industrialized Countries." *American Journal of Clinical Nutrition*, 20 (March 1967), 279-81.
- Main, Gloria L. "Probate Records as a Source for Early American History." *William and Mary Quarterly*, 3d Ser., 32 (Jan. 1975), 89-99.
- Mead, Margaret. *Food Habits Research: Problems of the 1960's*. Publication 1225. Washington: National Research Council, National Academy of Sciences, 1964.
- Menard, Russell R., P. M. G. Harris, and Lois Green Carr. "Opportunity and Inequality: The Distribution of Wealth on the Lower Western Shore of Maryland, 1638-1705." *Maryland Historical Magazine*, 69 (1974), 169-84.
- Miller, Henry M. "Pettus and Utopia: A Comparison of the Faunal Remains from Two Late Seventeenth Century Virginia Households." Paper presented at the Conference on Historic Sites Archaeology, Winston Salem, N. C., 1978. Manuscript at Virginia Research Center for Archaeology, Williamsburg.
- Mitchell, Helen S., and Natalie F. Joffe. "Food Patterns of Some European Countries: Background for Study Programs and Guidance of Relief Workers." *Journal of The American Dietetic Association*, 20 (Nov. 1944), 676-87.

- Moore, Frank W. "Methodologic Problems of Cross-Cultural Dietary Research." *Journal of The American Dietetic Association*, 45 (Nov. 1964), 415-19.
- Moore, John W., ed. *The Goods and Chattels of Our Forefathers: Frampton Cotterell and District Probate Inventories, 1539-1804*. Frampton Cotterell and District Historical Studies, I. London: Phillimore, 1976.
- Noel Hume, Audrey. "A Group of Artifacts Recovered from an Eighteenth-Century Well in Williamsburg." In *Five Artifact Studies*. Colonial Williamsburg Colonial Papers in Archaeology. Vol. I. Ed. Ivor Noel Hume. Williamsburg: Colonial Williamsburg Foundation, 1973, pp. 1-24.
- . *Food*. Colonial Williamsburg Archaeological Series No. 9. Williamsburg: Colonial Williamsburg Foundation, 1978.
- Noel Hume, Ivor. *Here Lies Virginia: An Archaeologist's View of Colonial Life and History*. New York: Alfred A. Knopf, 1963.
- . *Historical Archaeology*. 1969; rpt. New York: W. W. Norton, 1975.
- . "Material Culture With the Dirt on It: A Virginia Perspective." In *Material Culture and the Study of American Life*. Ed. Ian M. G. Quimby. New York: W. W. Norton, 1975, pp. 21-40.
- Outlaw, Alain C. "An Interim Report, Governor's Land Archaeological District Excavations: The 1976 Season." 1978. Manuscript at Virginia Research Center for Archaeology, Williamsburg.
- Outlaw, Merry Abbit, Beverly A. Bogley, and Alain C. Outlaw. "Rich Man, Poor Man: Status Definition in Two Seventeenth Century Ceramic Assemblages from Kingsmill." Paper presented to the Society for Historical Archaeology, Annual Conference, Ottawa, Canada, 1977. Manuscript at Virginia Research Center for Archaeology, Williamsburg.
- Thorpe, James. *The Use of Manuscripts in Literary Research: Problems of Access and Literary Property Rights*. New York: Modern Language Association of America, 1974.
- Wilson, C. Anne. *Food and Drink in Britain: from the Stone Age to recent times*. London: Constable, 1973.
- Yoder, Don. "Historical Sources For American Traditional Cookery: Examples from the Pennsylvania German Culture." *Pennsylvania Folklife*, 20, No. 3 (Spring 1971), pp. 16-29.

Also see Appendix A.

B. SEVENTEENTH-CENTURY VIRGINIA

Manuscript Primary Sources

- Surry County, Virginia. Records. Book 1. Deeds, Wills, Etc., 1652-1672. Virginia State Library, microfilm reel 1.
- . Records. Book 2. Deeds, Wills, Etc., 1671-1684. Virginia State Library, microfilm reel 1.
- . Records. Book 3. Deeds, Wills, Etc., 1684-1687. Virginia State Library, microfilm reel 1.
- . Records. Book 4. Deeds, Wills, Etc., 1687-1694. Virginia State Library, microfilm reel 2.
- . Records. Book 5. Deeds, Wills, Etc., 1694-1709. Virginia State Library, microfilm reel 3.
- York County, Virginia. Records. Book 1. Deeds, Wills, Orders, Etc., 1633-1657, 1691-1694. Original and transcript. Virginia State Library, microfilm reel 1 and 1a.
- . Records. Book 2. Wills, Orders, Deeds, 1645-1649. Virginia State Library, microfilm reels 1 and 1a.
- . Records. Book 3. Deeds, Orders, Wills, Etc., 1657-1662. Original and transcript. Virginia State Library, microfilm reels 2 and 2a.
- . Records. Book 4. Deeds, Orders, Wills, Etc., 1665-1672. Original and transcript. Virginia State Library, microfilm reels 2 and 2a.
- . Records. Book 5. Deeds, Orders, Wills, Etc., 1672-1676. Original and transcript. Virginia State Library, microfilm reels 2 and 2a.
- . Records. Book 6. Deeds, Orders, Wills, Etc., 1677-1684. Original and transcript. Virginia State Library, microfilm reels 3 and 3a.

- Records. Book 7. Deeds, Orders, Wills, Etc.,
1684-1687. Original and transcript. Virginia State Library,
microfilm reels 3 and 3a.
- Records. Book 8. Deeds, Orders, Wills, Etc.,
1687-1691. Original and transcript. Virginia State Library,
microfilm reels 4 and 4a.
- Records. Book 9. Deeds, Orders, Wills, Etc.,
1691-1694. Original and transcript. Virginia State Library,
microfilm reels 4 and 4a.
- Records. Book 10. Deeds, Orders, Wills, Etc.,
1694-1697. Original and transcript. Virginia State Library,
microfilm reels 4 and 4a.
- Records. Book 11. Deeds, Orders, Wills, Etc.,
1698-1702. Original and transcript. Virginia State Library,
microfilm reels 5 and 5a.

Printed Primary Sources

- Beverley, Robert. *The History and Present State of Virginia*. Ed. Louis B. Wright. Chapel Hill: Univ. of North Carolina Press, 1947.
- Brown, Alexander, ed. *The Genesis of the United States: A Narrative of the Movement in England, 1605-1616*. 2 vols. 1890; rpt. New York: Russell and Russell, 1964.
- Byrd, William. *The Correspondence of the Three William Byrds of Westover, Virginia, 1684-1776*. Ed. Marion Tinling. Vol. 1. Virginia Historical Society Documents, Vol. 12. Charlottesville: Univ. Press of Virginia, 1977.
- Clayton, John. *The Reverend John Clayton, A Parson with a Scientific Mind: His Scientific Writings and Other Related Papers*. Ed. Edmund Berkeley and Dorothy Smith Berkeley. Virginia Historical Society Documents, Vol. 6. Charlottesville: Univ. Press of Virginia, 1965.
- Danckaerts, Jasper. *Journal of Jasper Danckaerts 1679-1680*. Ed. Bartlett Burleigh James and J. Franklin Jameson. 1913; rpt. New York: Barnes and Noble, 1952.

- Durand, of Dauphine. *A Huguenot Exile in Virginia: or Voyages of a Frenchman exiled for his Religion with a description of Virginia & Maryland*. Ed. Gilbert Chinard. The Hague, 1687; rpt. New York: Press of the Pioneers, 1934.
- Ewan, Joseph, and Nesta Ewan. *John Banister and His Natural History of Virginia 1678-1692*. Urbana: Univ. of Illinois Press, 1970.
- Fitzhugh, William. *William Fitzhugh and His Chesapeake World 1676-1701: The Fitzhugh Letters and Other Documents*. Ed. Richard Beale Davis. Virginia Historical Society Documents, Vol. 3. Chapel Hill: Univ. of North Carolina Press, 1963.
- Fontaine, John. *The Journal of John Fontaine: An Irish Huguenot Son in Spain and Virginia 1710-1719*. Ed. Edward Porter Alexander. Williamsburg: Colonial Williamsburg Foundation, 1972.
- Force, Peter, ed. *Tracts and Other Papers, relating principally to the Origin, Settlement, and Progress of the Colonies in North America, from the discovery of the country to the year 1776*. Vol. II and III. 1836, 1844; rpt. New York: Peter Smith, 1947.
- Glover, Thomas. *An Account of Virginia, its Scituation, Temperature, Productions, Inhabitants and their manner of planting and ordering Tobacco &c.* 1676; rpt. Oxford: B. H. Blackwell, 1904.
- Hamor, Ralph. *A True Discourse of the Present State of Virginia*. London, 1615; rpt. Richmond: Virginia State Library, 1957.
- Harriot, Thomas. *A Brief and True Report of the New Found Land of Virginia*. Frankfurt, 1590; rpt. New York: Dover, 1972.
- Holme, Randle. *The Academy of Armory, or a Storehouse of Armory and Blazon*. Through Book 3, Chap. 13. Chester: n. p., 1688.
- . *The Academy of Armory, or a Storehouse of Armory and Blazon*. Book 3, Chap. 14, through Book 4, Chap. 13. Ed. I. H. Jeayes. London: Roxburghe Club, 1905.
- Johnson, Robert. *The New Life of Virginea*. London, 1612; rpt. Amsterdam: Theatrum Orbis Terrarum Ltd.; New York: Da Capo Press, 1971.

- Lawson, John. *A New Voyage to Carolina*. Ed. Hugh Talmage Lefler. Chapel Hill: Univ. of North Carolina Press, 1967.
- Markham, Gervase. *Countray Contentments*. London, 1615; rpt. Amsterdam: Theatrum Orbis Terrarum; New York: Da Capo Press, 1973.
- Michel, Francis, Louis. "Report of the Journey of Francis Louis Michel from Berne, Switzerland, to Virginia, October 2, 1701-December 1, 1702. Trans. and ed. William J. Hinke. *Virginia Magazine of History and Biography*. 24 (1916), 1-43, 113-41.
- Percy, George. *Observations Gathered out of "A Discourse of the Plantation of the Southern Colony in Virginia by the English, 1606."* Ed. David B. Quinn. Charlottesville: Univ. Press of Virginia, 1967.
- Plummer, John, ed. *The Hours of Catherine of Cleves* (c. 1440). New York: George Braziller, 1966.
- Quinn, David B., ed. *The Extension of Settlement in Florida, Virginia, and the Spanish Southwest*. Vol. 5 of *New American World: A Documentary History of North America to 1612*. New York: Arno Press, 1979.
- Quinn, David B., and Alison M. Quinn. *Virginia Voyages from Hakluyt*. London: Oxford Univ. Press, 1973, pp. 1-12.
- Rolfe, John. *A True Relation of the State of Virginia Lefte by Sir Thomas Dale Knight in May Last 1616*. Charlottesville: Univ. Press of Virginia, 1971.
- Smith, John. *A Map of Virginia. With a Description of the Countrey, the Commodities, People, Government and Religion*. Oxford, 1612; rpt. Amsterdam: Theatrum Orbis Terrarum Ltd.; New York: Da Capo Press, 1973.
- Smith, John. *Travels and Works of Captain John Smith*. Ed. Edward Arber and A. G. Bradley. 2 vol. Edinburgh: John Grant, 1910.
- The Three Charters of the Virginia Company of London with Seven Related Documents; 1606-1621*. Williamsburg: Virginia 350th Anniversary Celebration Corporation, 1957.
- Tyler, Lyon Gardiner, ed. *Narratives of Early Virginia 1606-1625*. New York: Charles Scribner's Sons, 1907.

- Waterhouse, Edward. *A Declaration of the State of the Colony in Virginia*. London, 1622; rpt. Amsterdam: Theatrum Orbis Terrarum Ltd.; New York: Da Capo Press, 1970.
- Westmoreland County Records. "Agreement Between Corbin, Lee, &c., to Build a Banqueting House." *Virginia Magazine of History and Biography*, 8 (Oct. 1900), 171-72.
- Wright, Louis B., ed. *A Voyage to Virginia in 1609: Two Narratives, Strachey's "True Reportory," Jourdain's "Discovery of the Bermudas."* Charlottesville: Univ. Press of Virginia, 1964.

Secondary Sources

- Ames, Susie M. *Studies of the Virginia Eastern Shore in the Seventeenth Century*. Richmond, Va.: Dietz Press, 1940.
- Anderson, Jay Allan. "'A Solid Sufficiency': An Ethnography of Yeoman Foodways in Stuart England." Diss. Univ. of Pennsylvania 1971.
- Bailey, Worth. "A Jamestown Baking Oven of the Seventeenth Century." *William and Mary Quarterly*, 2d Ser., 17 (Oct. 1937), 496-500.
- . "Notes on the Use of Pewter in Virginia During the Seventeenth Century." *William and Mary Quarterly*, 2d Ser., 18 (April 1938), 227-41.
- Beaudry, Mary, Janet Long, Henry Miller, Frazer Neiman, and Garry Stone. "A Vessel Typology for Early Chesapeake Ceramics: The Potomac Typological System." Paper presented at the Jamestown Archaeological Conference, Jamestown Island, Virginia, 18 May 1979.
- Brears, Peter C. D. *The English Country Pottery: Its History and Technique*. Newton Abbot, Devon: David and Charles, 1971.
- Bridenbaugh, Carl. *The Colonial Craftsman*. Chicago: Univ. of Chicago Press, 1961.
- Bruce, Philip Alexander. *Economic History of Virginia in the Seventeenth Century: An inquiry into the material condition of the people, based upon original and contemporaneous records*. 2 vols. 1895; rpt. New York: Peter Smith, 1935.

- . *Social Life of Virginia in the Seventeenth Century: An Inquiry into the origin of the higher planting class, together with an account of the habits, customs, and diversions of the people.* Richmond, Va.: privately published, 1907.
- Bugler, Caroline. *Dutch Painting in the Seventeenth Century.* New York: Mayflower Books, 1979.
- Campbell, Mildred. *The English Yeoman Under Elizabeth and the Early Stuarts.* 1942; rpt. New York: Augustus M. Kelley, 1968.
- Carr, Lois Green, and Lorena S. Walsh. "The Planter' Wife: The Experience of White Women in Seventeenth-Century Maryland." *William and Mary Quarterly*, 3d Ser., 34 (Oct. 1977), 542-71.
- Cotter, John L. *Archeological Excavations at Jamestown, Colonial National Historical Park and Jamestown National Historic Site, Virginia.* Archeological Research Series No. 4. Washington: National Park Service, U. S. Department of the Interior, 1958.
- Craven, Wesley Frank. *The Southern Colonies in the Seventeenth Century, 1607-1689.* Vol. I of *A History of the South.* Ed. Wendell Holmes Stephenson and E. Merton Coulter. N. p.: Louisiana State Univ. Press, 1970.
- . *White, Red, and Black: The Seventeenth-Century Virginian.* New York: W. W. Norton, 1977.
- Drummond, J. C., and Anne Wilbraham. *The Englishman's Food: A History of Five Centuries of English Diet.* Rev. Dorothy Hollingsworth. London: Jonathan Cape, 1957.
- Foote, Timothy, and the Editors of Time-Life Books. *The World of Bruegel c. 1525-1569.* New York: Time-Life Books, 1968.
- Forman, Henry Chandlee. *The Architecture of the Old South: The Medieval Style 1585-1850.* Cambridge, Mass: Harvard Univ. Press, 1948.
- Fussell, G. E. *The English Rural Labourer: His Home, Furniture, Clothing and Food from Tudor to Victorian Times.* London: Batchworth Press, 1949.
- Gray, Lewis Cecil. *History of Agriculture in the Southern United States To 1860.* Vol. I. Washington: Carnegie Institution of Washington, 1933.
- Haak, B. *Art Treasures of the Rijksmuseum, Amsterdam.* New York: Harry N. Abrams, 1966.

- Hartley, Dorothy. *Lost Country Life*. New York: Pantheon Books, 1979.
- Hecht, Irene W. D. "The Virginia Muster of 1624/25 As a Source for Demographic History." *William and Mary Quarterly*, 3d Ser., 30 (Oct. 1973), 65-92.
- Kelso, William. "An Interim Report on the Excavation at Kingsmill Plantation: The 1973 Season." March 1974. Manuscript at Virginia Research Center for Archaeology, Williamsburg.
- . "An Interim Report, Historical Archaeology at Kingsmill, The 1974 Season." March 1976. Manuscript at Virginia Research Center for Archaeology, Williamsburg.
- King, Sidney E., and J. Paul Hudson. *A Pictorial Album of Jamestown, "Birthplace of America."* N. p.: n. p., 1963.
- Klein, H. Arthur. *Graphic Worlds of Peter Bruegel the Elder: Reproducing 63 engravings and a woodcut after his designs*. New York: Dover, 1963.
- Laslett, Peter. *The World we have lost*. 2nd ed. London: Methuen, 1971.
- Lindsay, J. Seymour. *Iron and Brass Implements of the English House*. London: Alec Tiranti, 1964.
- Moller, Herbert. "Sex Composition and Correlated Culture Patterns of Colonial America." *William and Mary Quarterly*, 3d Ser., 2 (April 1945), 113-53.
- Moore, John S., ed. *The Goods and Chattels of Our Forefathers: Frampton Cotterell and District Probate Inventories 1539-1804*. Frampton Cotterell and District Historical Studies, 1. London: Phillimore, 1976.
- Munz, Ludwig. *Bruegel: The Drawings*. Complete ed. London: Phaidon, 1961.
- Nash, J. M. *The age of Rembrandt and Vermeer: Dutch painting in the seventeenth century*. 2nd ed. Oxford: Phaidon, 1979.
- Noel Hume, Audrey. *Food*. Colonial Williamsburg Archaeological Series No. 9. Williamsburg: Colonial Williamsburg Foundation, 1978.
- Noel Hume, Ivor. *Early English Delftware from London and Virginia*. Colonial Williamsburg Occasional Papers in Archaeology. Vol. 11.

- Ed. Ivor Noel Hume. Williamsburg: Colonial Williamsburg Foundation, 1977.
- ". "First Look at a Lost Virginia Settlement." *National Geographic*, 155 (June 1979), 734-67.
- Outlaw, Alain C. "An Interim Report, Governor's Land Archaeological District Excavations: The 1976 Season." May 1978. Manuscript at Virginia Research Center for Archaeology, Williamsburg.
- Phillips, Ulrich Bonnell. *Life and Labor in the Old South*. New York: Grosset and Dunlap, 1929.
- Quimby, Ian M. G., ed. *Arts of the Anglo-American Community in the Seventeenth Century*. Winterthur Conference Report, 1974. Charlottesville: Univ. Press of Virginia, 1975.
- Sauer, Carl Ortwin. *Sixteenth Century North America: The Land and the People as Seen by the Europeans*. Berkeley: Univ. of California Press, 1975.
- Slatkes, Leonard J. *Vermeer and His Contemporaries*. New York: Abbeville Press, 1981.
- Smith, James Morton. *Seventeenth-Century America: Essays in Colonial History*. 1959; rpt. New York: W. W. Norton, 1972.
- Stanard, Mary Newton. *Colonial Virginia: Its People and Customs*. 1917; rpt. Detroit: Singing Tree Press, 1970.
- Stith, William. *The History of the First Discovery and Settlement of Virginia: Being An Essay towards a General History of this Colony*. 1747; rpt. Spartansburg, S. C.: Reprint Company, 1965.
- Tate, Thad W., and David L. Ammerman. *The Chesapeake in the Seventeenth Century: Essays on Anglo-American Society*. New York: W. W. Norton, 1979.
- Trevelyan, George Macaulay. *English Social History: A survey of six centuries from Chaucer to Queen Victoria*. Rev. ed. London: Longman, 1978.
- Watkins, C. Malcolm. "North Devon Pottery and its Export to America in the 17th Century." *United States National Museum Bulletin* 225. Contributions from the Museum of History and Technology, Paper 13. Washington: Smithsonian Institution, 1960, pp. 17-59.

- Wertenbaker, Thomas Jefferson. *The First Americans 1607-1690*. Vol. II of *A History of American Life*. Ed. Arthur M. Schlesinger and Dixon Ryan Fox. New York: Macmillan, 1938.
- . *Patrician and Plebian in Virginia, or the Origin and Development of the Social Classes of the Old Dominion*. Charlottesville, Va.: privately published, 1910.
- . *The Planters of Colonial Virginia*. Princeton, N. J.: Princeton Univ. Press, 1922.
- Williams, Neville. "The Tribulations of John Bland, Merchant: London, Seville, Jamestown, Tangier, 1643-1680." *Virginia Magazine of History and Biography*, 72 (Jan. 1964), 19-41.
- Wright, Louis B. *The Cultural Life of the American Colonies 1607-1763*. 1957; rpt. New York: Harper and Row, 1962.

APPENDICES

Appendix A

A METHOD FOR STUDYING HISTORICAL CUISINES: AN ANNOTATED CHECKLIST

This checklist includes publications which relate both directly and indirectly to the historical study of food. In reviewing the publications I have sought the focus of each study, the stated or implied research method, the study's strengths and weaknesses, and—most importantly—the ideas and techniques which might be applied in studying historical cuisines.

Seven sections comprise the checklist: Food History; Food and Culture (Anthropology); Food Habits and Nutritional Anthropology; Folklore and Material Culture; Historical Archaeology and Art History; American Food History and Colonial Life; and Food in Colonial Virginia.

I. FOOD HISTORY

Aymard, Maurice. "Toward the History of Nutrition: Some Methodological Remarks." In *Food and Drink in History: Selections from the Annales Economies, Societes, Civilisations*. Vol. 5. Ed. Robert Forster and Orest Ranum. Trans. Elborg Forster and Patricia M. Ranum. Baltimore: Johns Hopkins Univ. Press, 1979, pp. 1-16.

Aymard outlines three major avenues to a study of the history of nutrition: the psychosociology of diet; the macroeconomic approach; and the study of the nutritional value of foodstuffs. He suggests a

system of quantitative data classification based on production and consumption data, sets forth cautions in the evaluation of quantitative data, and discusses the framework of a dietary regime.

Bonnet, Jean-Claude. "The Culinary System in the *Encyclopedie*." In *Food and Drink in History: Selections from the Annales Economies, Societes, Civilisations*. Vol 5. Ed. Robert Forster and Orest Ranum. Trans. Elborg Forster and Patricia M. Ranum. Baltimore: Johns Hopkins Univ. Press, 1979, pp. 139-65.

Bonnet has organized the references to food preparation in Diderot's *Encyclopedie* in a structured framework, with the food references correlated to other intellectual concepts in eighteenth-century French society. He describes how seventeenth-century learning turned its back on tastes and flavors which defied analysis, in a preoccupation with classifiable, definable matters.

Chang, K. C., ed. *Food in Chinese Culture: Anthropological and Historical Perspectives*. New Haven and London: Yale Univ. Press, 1977.

In his introduction to this descriptive history of food in China, Chang writes that a theoretical and methodological framework for the study of food as a cultural process does not exist in anthropological literature, and he suggests an outline of research questions toward the end of developing such a framework. Chang identifies the common themes of the Chinese cuisine, states objective criteria for measuring the relative inventiveness in and degree of preoccupation with food and eating among a people, and discusses issues concerning a study of food from an anthropological perspective. Findings in the Chang study are

based on archaeological data, textual sources, pictorial art, and literature.

Cummings, Richard Osborn. *The American and His Food: A History of Food Habits in the United States*. Rev. ed. 1941; rpt. New York: Arno Press, 1970.

Cummings' work is the American counterpart to Drummond and Wilbraham's English study. Based on statistical sources, it is the history of the American diet (not cuisine) from 1800 through 1940. Data include the per capita consumption of foods, the seasonal availability of foods, food budgets, the retail cost of calories, and food expenditures.

Dengler, Ian C. "What We Eat." *University Publishing*, Fall 1979, pp. 7-8.

In this review of books on food history, Dengler comments on the superiority of French archival research over the descriptive summaries of general periods which are favored by American writers who work in isolation without a common forum. Pointing out that food history is now in its infancy, he says, "it is likely to be some time before we achieve a common methodology."

Drummond, J. C., and Anne Wilbraham. *The Englishman's Food: A History of Five Centuries of English Diet*. Rev. Dorothy Hollingsworth. London: Jonathan Cape, 1957.

Often identified as a touchstone or classic study in food history, Drummond and Wilbraham's book is the history of a diet rather than the history of a cuisine. Based on quantitative economic and

production data, the study gives special attention to institutional diets and to the diets of social classes.

Flynn, Margaret Alberi. "Dining With Samuel Pepys in Seventeenth Century England." *Journal of The American Dietetic Association*, 20 (July-August 1944), 434-40.

This interesting but flawed article is based on literary sources, including early cookbooks. Flynn provides no documentation beyond occasional references to book sources, and she does not systematically justify her conclusions and judgments.

Lemon, James T. "Household Consumption in Eighteenth-Century America and its Relationship to Production and Trade: The Situation Among Farmers in Southeastern Pennsylvania." *Agricultural History*, 41 (Jan. 1967), 59-70.

This study analyzes a sample of 159 wills to describe in detail the food and clothing used by widows in eighteenth-century Pennsylvania.

McKearin, Helen. "Sweetmeats in splendor: eighteenth-century desserts and their dressing out." *Antiques*, 67 (March 1955), 216-25.

McKearin has arrived at a description of eighteenth-century desserts through the study of cookbooks, museum artifacts, and period drawings. She accepts newspaper ads for cookbooks as evidence of their use or influence.

Owen, Joan Hildreth. "Philosophy in the Kitchen; or Problems in Eighteenth-Century Culinary Aesthetics." *Eighteenth Century Studies*, 3 (1976-1977), 77-79.

Owen relates "taste" in culinary matters to "taste" in literature and the arts, and she suggests that eighteenth-century gastronomy in

Britain had styles which paralleled those of the classic, pastoral, and moral styles of eighteenth-century English literature. Owen observes that many problems of eighteenth-century culinary practices remain unsolved: the actual service of food; the temperature, preparation time, and quantity of food served; and the exact composition, execution, and occasion of elaborate meals.

Sass, Lorna J. *To The King's Taste: Richard II's book of feasts and recipes adapted for modern cooking*. New York: Metropolitan Museum of Art, 1975.

----- . *To the Queen's Taste: Elizabethan feasts adapted for modern cooking*. New York: Metropolitan Museum of Art, 1976.

----- . *Dinner with Tom Jones: Eighteenth-century cookery adapted for the modern kitchen*. New York: Metropolitan Museum of Art, 1977.

Based on documentary sources, these three books are examples of the better "re-creative" cookbooks, or books which present historical recipes in modern adaptations which remain remarkably faithful to their originals. Each book has an informal but scholarly (documented) introduction and a good bibliography of mostly primary or scholarly sources. Each recipe is presented first in a quotation from a historical source and then in its modern adaptation.

Wilson, C. Anne. *Food and Drink in Britain: from the Stone Age to recent times*. London: Constable, 1973.

Wilson presents a history of cookery rather than a history of diet, in a study quite different from the better known one by Drummond and Wilbraham. Based on literary sources, especially museum cookbook

collections, her work emphasizes the logical development of a cuisine and gives considerable attention to food preparation.

Yoder, Don. See entries in Section IV.

II. FOOD AND CULTURE (ANTHROPOLOGY)

Chang, K. C. See entry in Section I.

Clark, Priscilla P. "Thoughts for Food, I: French Cuisine and French Culture." *French Review*, 49 (Oct. 1975), 32-41.

Clark has suggested that a cuisine is best analyzed as a process involving products, functions, and actors, in a sequence of creation, production, diffusion, and reception or consumption. She suggests that a cuisine involves both an abstract (recipe) product and a tangible (meal) product. Clark also attempts to codify a culinary aesthetic, and her approach is more philosophical than systematic.

----- . "Thoughts for Food, II: Culinary Culture in Contemporary France." *French Review*, 49 (Dec. 1975), 198-205.

Clark expands her concept of a culinary system into a cyclic scheme of creation (cook, chef), production (kitchen, restaurant, home), consumption (diner, reader), and diffusion (cookbooks or writings about food), followed by a return to creation.

Douglas, Mary. "Deciphering a Meal." In *Myth, Symbol, and Culture*. Ed. Clifford Geertz. New York: W. W. Norton, 1974, pp. 61-81.

Douglas poses the question, "If food is a code, where is the precoded message?" In a combination of linguistic and anthropological theories she attempts to codify food combinations and menus. She uses letters and numbers to represent menu elements and structures, and then uses formulas to represent meals. She also relates food codes to social codes.

Gillespie, Angus K. "Toward a Method for the Study of Food in American Culture." *Journal of American Culture*, 2 (Fall 1979), 393-406.

This critical review of methods employed in the study of food in the disciplines of anthropology, history, and folklife points out both the strengths and weaknesses of the methods discussed. Gillespie does not, however, propose or recommend a specific method for the study of food in relation to culture.

Harper, Laura Jane. "A Possible Framework for Studying Food in Culture." Unpublished paper. Virginia Polytechnic Institute and State University, 1980.

Harper discusses the need for a method for the study of food in culture and examines the efforts of some other scholars toward that end. She proposes a framework of research questions based on larger variables pertaining to the physical factors and customs within a food culture and smaller variables pertaining to the social factors which determine the food pattern.

Harris, Robert S. "Influences of Culture on Man's Diet." *Archives of Environmental Health*, 5 (Aug. 1962), 144-52.

This article with a misleadingly broad title is actually a report on a clinical nutritional study of Otomi Indians in Mexico. Harris concludes that the cultural approach can be used to promote the efficient use of food supplies; he does not explain his method.

Leach, Edmund. *claude levi-strauss*. New York: Viking Press, 1970.
 Leach, in a chapter titled "Oysters, Smoked Salmon, and Stilton Cheese" (pp. 15-32), explains and interprets the Levi-Strauss culinary triangle concept. He concedes that Levi-Strauss' writing has "an element of verbal sleight of hand which invites caution rather than enthusiasm," yet he insists that the culinary triangle has wide application.

Levi-Strauss, Claude. "The Culinary Triangle." Trans. Peter Brooks. *Partisan Review*, 33 (1966), 586-95.

Levi-Strauss employs a structural theory of cookery as a basis for the interpretation of myths. Working from concepts of linguistics, he uses binary coding to contrast raw and cooked, natural and transformed foods in what he terms a "culinary triangle" of raw/cooked/rotted, with the cooked food considered transformed by cultural means and the rotted food considered transformed by natural means. Especially interesting are the social implications Levi-Strauss sees in the contrast of boiled and roasted meat.

----- . *The Origin of Table Manners, Introduction to a Science of Mythology: 3*. Trans. John and Doreen Weightman. New York: Harper and Row, 1968.

In a chapter titled "A Short Treatise on Culinary Anthropology" (pp. 471-95), Levi-Strauss presents a theory of recipes in terms of boiling and roasting, in accordance with his culinary triangle concept.

------. *The Raw and the Cooked, Introduction to a Science of Mythology: I.* Trans. John and Doreen Weightman. New York: Harper and Row, 1969.

Levi-Strauss uses his raw/cooked/rotted culinary triangle as a base for a broader mythology or symbolism dealing with puberty and childbirth rites, incest, and wild pigs.

Sorre, Max. "The Geography of Diet." In *Readings in Cultural Geography*. Ed. and trans. Philip L. Wagner and Marvin W. Mikesell. Chicago: Univ. of Chicago Press, 1962, pp. 445-56.

Sorre describes diets as expressions of the environment, with the climate setting nutritional requirements and ecological conditions determining the composition and abundance of foods. His work is concerned with the solution of dietary problems, with findings based on statistical research.

III. FOOD HABITS AND NUTRITIONAL ANTHROPOLOGY

Committee on Food Habits. "Manual for the Study of Food Habits." *National Research Council Bulletin 111*. Washington: National Research Council, National Academy of Sciences, 1945.

This manual presents a detailed and extensive outline for data collection which can be adapted for historical studies of food. The broad categories of data include the food pattern, the social organization of food, the ideology of food, the induction of the new

generation into the food pattern, the material culture and technology of food, the food pathology, and the study of stability and change.

Fathauer, George H. "Food Habits--An Anthropologist's View." *Journal of The American Dietetic Association*, 37 (Oct. 1960), 335-38.

Fathauer points out that the anthropologist's study of food habits is concerned with culture-related dietary problems, with the relation of a "way of life" to food habits or dietary practices, and with the social and emotional significance of food.

Garine, Igor de. "The Socio-Cultural Aspects of Nutrition." *Ecology of Food and Nutrition*, 1 (1972), 143-63.

Garine writes that we need to examine explicit gastronomic codes in highly sophisticated societies as a prelude to nutritional change, and he discusses the difficulty of naming the organoleptic characteristics of foods and dishes. He suggests the analysis of oral literature, myths, tales, and common sayings in the definition of a "culinary theory."

Jelliffe, Derrick B. "Parallel Food Classifications in Developing and Industrialized Countries." *American Journal of Clinical Nutrition*, 20 (March 1967), 279-81.

Jelliffe classifies foods as cultural superfoods, prestige foods, body-image foods, sympathetic magic foods, and physiologic group foods. He suggests that these classifications are common to all parts of the world, and that they often have a public health significance in developing regions.

Mead, Margaret. *Food Habits Research: Problems of the 1960's*. Publication 1225. Washington: National Research Council, National Academy of Sciences, 1964.

Mead writes of the need for a code to provide for a formal description of a people's dietary pattern, including these aspects of food: physiological sensory terms; chemical terms; nutritional terms; and cultural terms (pertaining to agriculture, economics, socio-culture, education, food handling, and dietary patterning).

Mitchell, Helen S., and Natalie F. Joffe. "Food Patterns of Some European Countries: Background for Study Programs and Guidance of Relief Workers." *Journal of The American Dietetic Association*, 20 (Nov. 1944), 676-87.

Mitchell and Joffe present a schematic picture of the food habits of thirteen European countries, with data compiled in a chart form. They classify the foods eaten according to the "basic 7" food groups. The social matrix within which the foods were used is identified for both rural and urban areas by sources of food, kitchen and table equipment, cooking methods, meal patterns, food for special states or ages, and beliefs and attitudes toward food. The chart organization is intended to point up the strengths and weaknesses within a dietary pattern rather than to define a cuisine; the French and Italian data illustrate how this schematic method gives little or no sense of the cuisine--of the style of food preparation.

Moore, Frank W. "Methodologic Problems of Cross-Cultural Dietary Research." *Journal of The American Dietetic Association*, 45 (Nov. 1964), 415-19.

Moore describes the Human Relation Area Files effort to collect and organize dietary data on pre-industrial societies. He reports that a

problem in contemporary survey data collection is the design of a coding sheet to insure uniformity and accuracy, and to include needed information. He attempted to include taste, odor, and texture as data classes but could not devise a classification system for sensory qualities. The article includes examples of data sheets for recording data on the food source, for information pertaining to the society, and for "essay-type" descriptive reports by ethnographers. Moore points out the general failing of the literature to report details of food preparation, of the prestige value of foods, and of the acceptability of foods, although that information is generally covered in questionnaires.

Pelto, Gretel H. "Anthropological Contributions to Nutrition Education Research." *Journal of Nutrition Education*, 13 (Supplement 1981), S2-S8.

Within the context of the study of dietary behavior, Pelto proposes a "lifestyle" model in which lifestyle factors (income, occupation, education, ethnic identity, rural-urban residence, religious beliefs, health beliefs, nutrition knowledge, and physiological characteristics) interact with household structure and composition as well as with the food production and distribution system and the social-economic-political system to comprise a lifestyle which affects a food intake behavior.

Wilson, Christine S. "Research Methods in Nutritional Anthropology: Approaches and Techniques." In *Nutrition and Anthropology in Action*. Ed. Thomas K. Fitzgerald. Assen: van Gorcum, 1977, pp. 62-68.

Wilson describes nutritional anthropology as a facet of medical anthropology, generally given to practical application. She points out that anthropological techniques suitable for the study of diet and food intake in a culture can be used in a contemporary setting.

IV. FOLKLORE AND MATERIAL CULTURE

Anderson, Jay Allen. "'A Solid Sufficiency': An Ethnography of Yeoman Foodways in Stuart England." Diss. Univ. of Pennsylvania 1971.

Anderson has based his study of the foodways heritage of seventeenth-century New Englanders on printed documentary sources. Alas, although he introduces his study with a discussion of the need for scholarly advances in the historical study of food habits, and although he employs what he describes as a foodways model, he does not outline or describe his model or methodology.

Brunvand, Jan Harold. "Folk Costumes and Foods." In *The Study of American Folklore: An Introduction*. New York: W. W. Norton, 1968, pp. 287-301.

In his discussion of folk foods Brunvand concentrates on pioneer and frontier cookery, but he also mentions the Indian influence on American food, ship's fare during the early period of American history, and the evolution of names for American foods. He suggests contemporary newspapers, folk songs, and contemporary literature as sources for the study of folk foods, but he does not discuss a methodology.

Fleming, E. McClung. "Artifact Study: A Proposed Model." In *Winterthur Portfolio* 9. Ed. Ian M. G. Quimby. Charlottesville: Univ. Press of Virginia, 1974, pp. 153-73.

Fleming proposes a model for artifact study and applies it to the study of a seventeenth-century American court cupboard. He identifies five properties necessary for the study of an artifact: its history, its material, its construction, its design, and its function; and he performs four operations on those properties: identification, evaluation, cultural analysis, and interpretation. In the study of food in history and in culture, artifacts are but clues--not beginning, focus, and end as in Fleming's model--but Fleming's comprehensive and orderly model can nonetheless be modified for or applied to the detailed study of artifacts relating to the storage, preparation, and service of food.

Glassie, Henry. *Pattern in the Material Folk Culture of the Eastern United States*. Philadelphia: Univ. of Pennsylvania Press, 1968.

Glassie's book reflects his special interest in folk architecture, but it is useful to scholars in other fields for its precise definitions of folk objects and folk material. Glassie defines folk objects as traditional and non-popular items marketed and used locally (pp. 6, 12), and folk material as that which varies greatly over space and little over time, in contrast with popular material which varies little over space and much over time (p. 33). This might suggest that folklore methods of research may be more appropriate for regional studies of food than for historical studies, but folklore methods can indeed be useful in defining and describing the characteristics of a cuisine.

Yoder, Don. "Historical Sources For American Traditional Cookery: Examples from the Pennsylvania German Culture." *Pennsylvania Folklife*, 20, No. 3 (Spring 1971), pp. 16-29.

Yoder discusses problems in cookery research and suggests values and problems in the use of historical materials. He identifies appropriate historical sources for the study of cookery as printed texts (travelers' accounts, cookbooks, government reports, laws, newspapers, periodicals, literature, almanacs, broadsides, biographies and autobiographies, local histories); manuscript sources (personal papers and personal legal documents such as wills and estate inventories); and iconographic sources (illustrations in books and periodical literature, manuscript drawings, and sketchbooks).

----- "Folk Cookery." In *Folklore and Folklife: An Introduction*. Ed. Richard M. Dorson. Chicago: Univ. of Chicago Press, 1972, pp. 327-50.

Yoder has used the term "foodways" to describe the total cookery complex in a society and states that the study of folk cookery includes the study of the foods themselves, their morphology, their preparation, their preservation, their social and psychological functions, and their ramifications into all other aspects of a folk culture. He reports that European studies identify as historical determinants of cookery and foodways: environment and climate; settlement history and ethnic demography; technology; economic history; sociological factors; and religion.

V. HISTORICAL ARCHAEOLOGY AND ART HISTORY

Horn, Walter, and Ernest Born. *The Plan of St. Gall: A Study of the Architecture and Economy of, and Life in a Paradigmatic Carolingian Monastery*. 3 vols. Berkeley: Univ. of California Press, 1979.

Horn has described the pattern of daily life in a paradigmatic early medieval monastery from the evidence of the architectural plan for St. Gall, from documentary records, and from pictorial and documentary records of comparable or related sites. The three-volume publication (designed and illustrated by Born) combines straightforward clarity with scholarly density; both the research discipline in this study and the presentation of its findings can serve as model and inspiration for the scholar whose goal is the definition of daily life in history.

Noel Hume, Audrey. *Archaeology and the Colonial Gardener*. Colonial Williamsburg Archaeological Series No. 7. Williamsburg: Colonial Williamsburg Foundation, 1974.

Noel Hume reports that fruit pits, vegetable seeds, and grape vines found and identified by archaeologists working at Williamsburg provide data on the fruits and vegetables present in Williamsburg's eighteenth-century food culture. Gardening objects (flower pots, bell glasses, hand glasses, tools) found in the excavations provide clues to the kind of gardening which was possible or typical in colonial times.

----- . *Food*. Colonial Williamsburg Archaeological Series No. 9. Williamsburg: Colonial Williamsburg Foundation, 1978.

This fine study of colonial Virginian food may be unique as a historical study based upon original research on that food culture. Noel Hume

bases her report on archaeological findings around Williamsburg, and she uses literary sources (especially diaries) and paintings to help explain the artifacts.

Noel Hume, Ivor. *Historical Archaeology*. 1969; rpt. New York: W. W. Norton, 1975.

This textbook of methodology in historical archaeology includes detailed and practical information on photography and record keeping in on-site research. Especially useful to the researcher in historical cuisines are Noel Hume's discussions of the relation of historical documents to historical artifacts and his observation that while anthropologists study things and historians study documents, historical archaeologists study things in relation to documents (pp. 7-20). He identifies contemporary newspapers, diaries, letter books, waste books, commonplace books, ledgers, insurance policies, and court, tax, and church records as good sources of information on seventeenth- and eighteenth-century objects (p. 18), and he mentions the importance of studying fashions as well as trade regulations and restrictions which affected the presence of specific items (p. 16).

----- . *The Wells of Williamsburg: Colonial Time Capsules*. Colonial Williamsburg Archaeological Series No. 4. Williamsburg: Colonial Williamsburg Foundation, 1969.

Abandoned wells in colonial Williamsburg served as garbage pits and thus as repositories for plant and animal wastes, kitchen utensils, pottery, china, and glassware. Bones, seeds, leaves, and nuts provide clues for the identification of specific foods of colonial

Williamsburg. Noel Hume correlates excavated artifacts with the pictorial evidence of signs and paintings, as well as with the evidence of documents.

VI. AMERICAN FOOD HISTORY AND COLONIAL LIFE

Barber, Edith M. "The Development of the American Food Pattern." *Journal of the American Dietetic Association*, 24 (July 1948), 586-91.

This review or survey-type article has no documentation. It traces the evolution of the American food pattern from primitive man to the emergence of knowledge about nutrition. Topics include food contributions of the New World, food imports to the Americas, the influence of the fork, and early American cookbooks.

Belden, Louise C. "The colonial dessert table." *Antiques*, 108 (Dec. 1975), 1156-63.

This article describes the styles and fashions in dessert service among early Americans transplanted from the elegance of European society, with emphasis on the late eighteenth century. Belden has used documents and museum artifacts in her research, as well as archival and pictorial materials.

Bennion, Marion. "Food preparation in colonial America." *Journal of The American Dietetic Association*, 69 (July 1976), 16-23.

This article is an uncritical survey of secondary sources, both scholarly and popular, relating to colonial American food.

Booth, Sally Smith. *Hung, Strung, and Potted: A History of Eating in Colonial America*. New York: Clarkson N. Potter, 1971.

This popular work appears to be well researched from primary sources but has no documentation. Smith concentrates on a realistic view of the eating pattern of the general population rather than of the wealthy few. The book includes excellent illustrations: botanical drawings; drawings of Indians growing, preparing, and trading food; paintings; signs; and photos of artifacts.

Earle, Alice Morse. *Home Life in Colonial Days*. 1898; rpt. Stockbridge, Mass.: Berkshire Traveller Press, 1974.

This general work appears well researched from primary sources, but it has neither documentation nor bibliography. Earle somewhat romantically evokes the social and domestic atmosphere of colonial times. The book includes chapters on the kitchen fireside and on the serving of meals.

Hooker, Richard J. *Food and Drink in America: A History*. Indianapolis: Bobbs-Merrill Company, 1981.

This ambitious and well documented work by a historian is based on printed documentary sources. In its chapters on seventeenth-century food the exaggeration of fragmentary data into sweeping generalizations might be cited as a major flaw, along with the neglect of archaeological findings and of foodways concepts. Hooker also writes in terms of a single seventeenth-century food culture, without much attention to the variety and differences contingent upon economic, social, and physical factors.

Phipps, Frances. *Colonial Kitchens, Their Furnishings, and Their Gardens*. New York: Hawthorn Books, 1972.

Although popular in style, this useful book is meticulously scholarly in its documentation and in its use of primary sources. Phipps provides considerable information about food preparation and preservation methods, as well as descriptions of how colonial kitchen tools and utensils were used.

Root, Waverley, and Richard de Rochemont. *Eating in America: A History*. New York: William Morrow, 1976.

This well written account of America's culinary history is useful more for its ideas than for its facts. Most of the references included in the very useful annotated bibliography are secondary sources. The early sections of the book which discuss colonial Virginia have an imaginative, logical sense of the influences on and development of the earliest American cuisine.

Spruill, Julia Cherry. *Women's Life and Work in the Southern Colonies*. 1938; rpt. New York: W. W. Norton, 1972.

This well documented scholarly work in social history devotes little attention to the cuisine or style of cookery in the southern colonies. However, Spruill discusses household help and servants, hospitality, taverns and inns, and shopkeepers and tradeswomen. She also provides an extensive bibliography.

Stewart, George R. *American Ways of Life*. 1954; rpt. New York: Russell and Russell, 1971.

Two chapters of this book are devoted to food. Based on primary or original sources but undocumented, they give a good overview of the

history of American food with an emphasis on the logical development or evolution of a food pattern. Stewart identifies heredity and environment as the two major influences on culinary development, with individual creative ideas and "native development" serving as secondary influences.

Weigley, Emma Seifrit. "Food in the Days of the Declaration of Independence." *Journal of The American Dietetic Association*, 45 (July 1964), 35-39.

This article discusses the food of the frontier, of the farm, of the city, and of the plantation. It appears to be a pastiche of information chiefly from secondary sources, although some primary sources are cited.

VII. FOOD IN COLONIAL VIRGINIA

Bullock, Helen. *The Williamsburg Art of Cookery or, Accomplished Gentlewoman's Companion: Being a Collection of upwards of Five Hundred of the most Ancient and Approv'd Recipes in Virginia Cookery*. Williamsburg, Va.: Colonial Williamsburg, 1938.

This book was designed and printed in an eighteenth-century manner. The recipes are from cookbooks of varied vintages and include personal recipes from as late as 1937; most of the recipes are post-colonial.

Carson, Jane. *Colonial Virginia Cookery*. Williamsburg: Colonial Williamsburg, 1968.

Since most of Carson's material is of the late eighteenth century and even of the early nineteenth century, the book really emphasizes the

post-colonial, not colonial, period. The bulk of the book consists of material from printed cookbooks, chiefly middle and late eighteenth-century English books. The introduction provides a helpful discussion of sources for historical cookery research, and Carson includes many illustrations of colonial cooking utensils.

Community Nutrition Section of the Virginia Dietetic Association and the Dairy Council of Richmond. *Interesting Facts About Seventeenth Century Foods in Virginia*. N. p.: Community Nutrition Section of Virginia Dietetic Association and Dairy Council of Richmond, [c. 1957].

This small but serious pamphlet about the food of early Jamestown days is compiled chiefly of quotations from published primary sources.

Noel Hume, Audrey. See entries in Section V.

Noel Hume, Ivor. See entries in Section V.

Smallzried, Kathleen Ann. *The Everlasting Pleasure: Influences of America's Kitchens, Cooks and Cookery, from 1565 to the year 2000*. New York: Appleton-Century-Crofts, 1956.

This book has a brief, superficial, and sometimes confused discussion of colonial food. Chronological incoherence figures in the discussion of women as a minority *before* the "starving time," when no women were in the colony, and in the mention of forks in use before 1618. Isolated examples of food preparation methods are sometimes presented as common generalities—as in the description of small dome-shaped clay ovens set into walls.

Thomas, Gertrude I. *Foods of Our Forefathers*. Philadelphia: F. A. Davis, 1941.

Thomas discusses the food supply, the cookery practices, and the meal service in aboriginal and colonial Virginia. A non-scholarly work, her book appears to be researched chiefly from secondary sources, and it has little documentation. The book includes some errors (as in references to successful salt production and to the use of maple syrup at Jamestown). In speculations about malnutrition at Jamestown, Thomas suggests that the settlers had too much fiber and too little fat (pp. 19-22).

Appendix B
SELECTED EXTRACTS
FROM PUBLISHED PRIMARY SOURCES

Many primary accounts of seventeenth-century Virginia, especially from the Virginia Company years, are available either in facsimile printings or edited transcriptions.¹ These accounts frequently include references to food. Because the accounts are many, and the references to food scattered and often brief, selected extracts offering the more pertinent descriptions of food are transcribed or quoted in this appendix. Bracketed notes indicate the context of place or situation, explain archaic language, or supply missing words. In transcribing unedited texts I have substituted the modern J and V for the seventeenth-century I and U.

Extracts are arranged chronologically by date of original publication or date of manuscript; within a single year entries are arranged alphabetically by name of author or title of anonymous tract.

¹ For a discussion and evaluation of seventeenth-century literary sources, see Howard Mumford Jones, *The Literature of Virginia in the Seventeenth Century*, 2nd ed. (Charlottesville: Univ. Press of Virginia, 1968).

[1584].

"The first voyage made to the coastes of America, with two barkes, wherein were Captaines Master Philip Amadas, and Master Arthur Barlowe, who discovered part of the Countrey now called Virginia, Anno 1584: Written by one of the said Captaines, and sent to sir Walter Raleigh, knight, at whose charge, and direction, the said voyage was set foorth." In *Virginia Voyages from Hakluyt*. Ed. David B. Quinn and Alison M. Quinn. London: Oxford Univ. Press, 1973, pp. 1-12.

[Explanations within brackets are from the editors' notes.]

[The Indian king's brother] sent us every day a brase or two of fatte Buckes, Conies, Hares, Fishe, the best of the worlde. Hee sent us divers kindes of fruites, Melons, Walnuts, Cucumbers, Gourdes, Pease, and divers rootes, and fruites very excellent good, and of their Countrey corne, which is very white, faire, and well tasted, and groweth three times in five moneths . . . our selves proved the soile, and put some of our Pease into the ground, and in tenne daies they were of foureteene ynches high: they have also Beanes very faire, of divers colours and wonderfull plentie: some growing naturally, and some in their gardens, and so have they both wheat and oates [here Barlowe is mistaken]. (p. 7)

[The wife of the Indian king's brother] brought us into the inner roome, where shee set on the boord standing along the house, some wheate like furmentie [furmenty, wheat boiled in milk and seasoned; here maize, probably boiled with herbs for seasoning], sodden Venison, and roasted, fishe sodden [stewed with corn and beans], boyled, and roasted, Melons rawe, and sodden, rootes of divers kindes, and divers fruites: their drinke is commonly water, but while the grape lasteth, they drinke wine [a mistake, since the absence of deliberately fermented beverages in eastern North America was universal], and for want of caskes to keepe it all the yeere after, they drink water, but it is sodden with Ginger in it, and blacke Sinamon, and sometimes Sassaphras, and divers other wholesome, and medicinable hearbes and trees. (p. 8)

1588.

Thomas Harriot. "A briefe and true report of the new found land of Virginia (1588), as reprinted by Hakluyt in 1589." In *Virginia Voyages from Hakluyt*. Ed. David B. Quinn and Alison M. Quinn. London: Oxford Univ. Press, 1973, pp. 46-76.

[Explanations within brackets are from the editors' notes.]

We caryed thither Suger canes to plant. . . . So likewise for Orenge and Limmons: there may be planted also Quinses. Whereby may grow in reasonable time if the action be diligently prosecuted, no small commodities in Sugers, Suckets, and Marmelades. (p. 54)

Pagatowr [the Indian word for "things put in a kettle to boil"; corn roasted, boiled, and served as a gruel served as a base for most Indian dishes, cooked with meat, fish, and vegetables], a kinde of graine so called by the inhabitants: the same in the West Indies is called Mayze: English men call it Guinney wheat, or Turkie wheat, according to the names of the countries from whence the like hath bene brought. The graine is about the bignesse of our ordinary English peaze, and not much different in forme and shape: but of divers colours: some white, some red, some yellow, and some blew. All of them yeeld a very white and sweete flowre: being used according to his kinde, it maketh a very good bread. We made of the same in the countrey some mault, whereof was brued as good ale as was to be desired. So likewise by the helpe of hops, thereof may be made as good beere. It is a graine of marvellous great increase: of a thousand, fifteene hundred, and some two thousand folde. There are three sorts, of which two are ripe in eleven and twelve weeks at the most, sometimes in tenne, after the time they are set, and are then of height in stalke about sixe or seven foot. The other sort is ripe in foureteene. . . . Of these graines, besides bread, the inhabitants make victuall, either by parching them, or seething them whole untill they be broken: or boiling the flowre with water into a pappe.

Okingier, called by us Beanes, because in greatness and partly in shape they are like to the beanes in England, saving that they are flatter, of more divers colours, and some pide. The leafe also of the stemme is much different. In taste they are altogether as good as our English peaze.

Wickonzowr, called by us Peaze, in respect of the beanes for distinction sake, because they are much lesse, although in forme they little differ: but in goodnesse of taste much like, and are farre better then our English peaze. Both the beanes and peaze are ripe in tenne weeks after they are set. They make them victuall either by boiling them all to pieces into a broth, or boiling them whole untill they be soft, and begin to breake, as is used in England, either by themselves, or mixtly together:

sometime they mingle of the wheat with them: sometime also, being whole sodden, they bruse or punne them in a mortar, and thereof make loaves or lumps of dowish bread, which they use to eat for variety.

Macocquer, according to theyr several formes, called by us Pompions, Mellions [pumpkins or gourds—melons were a later introduction], and Gourds, because they are of the like formes as those kindes in England. In Virginia such of severall formes are of one taste, and very good, and do also spring from one seed. There are of two sorts: one is ripe in the space of a moneth, and the other in two moneths.

There is an herbe which in Dutch is called Melden [a member of the genus *Atriplex*, known as oraches or salt-bushes]. Some of those that I describe it unto, take it to be a kinde of Orage: it groweth about foure or five foot high; of the seed thereof they make a thicke broth, and pottage of a very good taste: of the stalke by burning into ashes they make a kinde of salt earth, wherewithall many use sometimes to season theyr broths: other salt they know not. We our selves used the leaves also for potherbs.

There is also another great herbe, in forme of a Marigolde, about sixe foot in height, the head with the floure is a spanne in bredth. Some take it to be *Planta Solis* [sunflower]: of the seeds heereof they make both a kind of bread and broth. (pp. 54-56)

[Harriot provides, pp. 56-67, an extensive description of the sowing and cultivating of corn.]

Openauk [ground-nut, Indian potato, or mash potato—confused by later writers with the potato] are a kinde of roots of round forme, some of the bignesse of walnuts, some farre greater, which are found in moist and marish grounds growing many together one by another in ropes, or as though they were fastened with a string. Being boiled or sodden they are very good meat.

Okeepenauk [probably man-of-the-earth or wild potato vine with a yam-like tap root] are also of round shape, found in drie grounds: some are of the bignesse of a mans head. They are to be eaten as they are taken out of the ground, for by reason of theyr drinesse they will neither roste nor seethe. Theyr taste is not so good as of the former roots, notwithstanding for want of bread, and sometimes for variety the inhabitants use to eat them with fish or flesh, and in my judgement they do as well as the housholde bread make of rie heere in England.

Kaishucpenauk [a member of the water-plantain family, especially the common arrow-head or duck potato, found on pond and river margins and in marshes] a white kinde of roots about the bignesse of henne egges, and neere of that forme: theyr taste was not so good to our seeming as of the other, and therefore theyr place and maner of growing, not so much cared for by us: the inhabitants notwithstanding used to boyle and eat many.

Tsinaw [one of the woody smilaxes] a kinde of root much like unto that which in England is called the China root brought from the East Indies. . . . From these roots while they be new or fresh, being chopt into small pieces, and stampd, is strained with water a juice that maketh bread, and also being boyled, a very good spoonemeat in maner of a gelly, and is much better in taste if it be tempered with oile [the roots were used widely in southeastern North America to make a reddish flour, a jelly, and a drink like sarsaparilla]. . . .

Coscushaw [a member of the arum family, apparently arrow-arum and golden-club], some of our company tooke to be that kinde of root which the Spanyards in the West Indies call Cassavy. . . . Being dressed according to the cuntry maner, it maketh a good bread, and also a good spoonemeat, and is used very much by the inhabitants: the juice of this root is poison, and therefore heed must be taken before any thing be made therewithall; either the roots must be first sliced and dried in the Sunne, or by the fire, and then being punned into floure, will make good bread: or els while they are greene they are to be pared, cut into pieces, and stampd: loaves of the same to be laid neere or over the fire untill it be sowre, and then being well punned againe, bread, or spoonemeat very good in taste and wholesome may be made thereof.

Habascon [perhaps the cow-parsnip which the Indians used as a salt substitute] is a root of hote taste, almost of the forme and bignesse of a parsnip, of it selfe it is no victuall, but onely a helpe being boyled together with other meats.

There are also Leeks, differing little from ours in England, that grow in many places of the cuntry, of which, when we came in places where they were, we gathered and eat many, but the naturall inhabitants never.

Of Fruites.

Chestnuts [the small coastal Chinquapin], there are in divers places great store: some they use to eat raw, some they stampe and boile to make spoonemeat, and with some

being sodden, they make such a manner of dowe bread as they use of theyr beanes before mentioned.

Walnuts: there are two kindes of walnuts [the smooth nut is probably the pig-nut hickory; the dark ragged-shelled one might have been the black walnut which tended to seed around Indian settlements], and of them infinite store. . . . The one kinde is of the same taste and forme, or little differing from ours of England, but that they are harder and thicker shelled: the other is greater, and hath a very ragged and hard shell: but the kernell great, very oily and sweet. Besides theyr eating of them after our ordinarie maner, they breake them with stones, and punne them in morters with water, to make a milke which they use to put into some sorts of theyr spoonemeat: also among theyr sod wheat, peaze, beanes and pompions which maketh them have a farre more pleasant taste.

Medlars a kinde of very good fruit, so called by us chiefly for these respects: first in that they are not good untill they be rotten: then in that they open at the head as our medlars, and are about the same bignesse: otherwise in taste and colour they are farre different: for they are as red as cherries, and very sweet: but whereas the cherie is sharpe sweet, they are lushious sweet.

Mutaquesunnauk [prickly pear], a kinde of pleasant fruit almost of the shape and bignesse of English peares, but that they are of a perfect red colour as well within as without. They grow on a plant whose leaves are very thicke, and full of prickles as sharpe as needles. . . .

Straberries there are as good and as great as those which we have in our English gardens.

Mulberies, Applecrabs, Hurts or Hurtleberies, such as we have in England.

Sacquenumener a kinde of berries almost like unto capers, but somewhat greater, which grow together in clusters upon a plant or herbe that is found in shallow waters: being boiled eight or nine houres according to theyr kinde are very good meat and wholesome, otherwise if they be eaten they will make a man for the time frantike or extremely sicke.

There is a kinde of Reed [possibly cord grass] which beareth a seed almost like unto our rie or wheat, and being boiled is good meat.

In our travels in some places we found Wilde peaze like unto ours in England, but that they were lesse, which are also good meat.

Of a kinde of fruit or berry in forme of Acornes.

There is a kinde of berrie or acorne, of which there are five sorts that grow on severall kindes of trees [not necessarily all from oaks—some may have been the Chinquapin or the hazel-nut; the oaks with sweetish acorns are the live oak, the post oaks, the white oak, and the basket oak]: the one is called Sagatemener, the second Osamener, the third Pummuckoner. These kinde of acornes they use to drie upon hurdles make of reeds, with fire underneath, almost after the maner as we dry malt in England. When they are to be used, they first water them untill they be soft, and then being sod, they make a good victuall, either to eat so simply, or els being also pounded to make loaves or lumps of bread. These be also the three kindes, of which, I said before the inhabitants used to make sweet oile.

Another sort is called Sapummener, which being boiled or parched, doth eat and taste like unto chestnuts. They sometimes also make bread of this sort.

The fift sort is called Mangummenauk, and is the acorne of theyr kinde of Oake, the which being dried after the maner of the first sorts, and afterward watered, they boile them and theyr servants, or sometimes the chiefe themselves, either for variety or for want of bread, do eat them with theyr fish or flesh. (pp. 59-62)

Of Fish.

For foure moneths of the yeere, February, March, Aprill and May, there are plenty of Sturgeons: And also in the same moneths of Herrings, some of the ordinary bignesse as ours in England, but the most part farre greater, of eighteene, twentie inches, and some two foot in length and better: both these kindes of fish in those moneths are most plentifull, and in best season, which we found to be most delicate and pleasant meat.

There are also Trouts: Porpoises: Rayes: Oldwives: Mulletts: Plaice: & very many other sorts of excellent good fish, which we have taken and eaten, whose names I know not but in the countrey language. . . .

Sea crabbes, such as we have in England.

Oisters, some very great, and some small, some round, and some of a long shape [including, perhaps, clams in this description]: they are found both in salt water and brackish, and those that we had out of salt water are far better then the other as in our countrey.

Also Muscles: Scalops: Periwinkles: and Crevises [the freshwater crayfish, probably also including the lobster].

Seekanauk [king-crab or horseshoe crab], a kinde of crusty shell fish, which is good meat, about a foot in bredth, having a crustie taile, many legges like a crab, and her eyes in her backe. . . .

There are many Tortoyses [land and sea turtles and terrapins] both of land and sea kinde, theyr backs and bellies are shelled very thicke, theyr head, feet, and taile, which are in appearance, seeme ougly, as though they were members of a serpent or venemous beasts: but notwithstanding they are very good meat, as also theyr egges. Some have beene found of a yard in bredth and better. (pp. 63-64)

1606.

George Percy. *Observations Gathered out of "A Discourse of the Plantation of the Southern Colony in Virginia by the English, 1606."* Ed. David B. Quinn. Charlottesville: Univ. Press of Virginia, 1967.

[Upon the first arrival in Chesapeake Bay:] We came to a place where [the Indians] had made a great fire, and had been newly roasting oysters. When they perceived our coming, they fled away to the mountains, and left many of the oysters in the fire. We ate some of the oysters, which were very large and delicate in taste. (pp. 8-9)

Upon this plot of ground [in Chesapeake Bay] we got good store of mussels and oysters, which lay on the ground as thick as stones. We opened some, and found in many of them pearls. (p. 9)

Going a little further, we came into a little plat of ground full of fine and beautiful strawberries, four times bigger and better than ours in England. (p. 10)

The chiefest of [the Indians] sat all in a rank; the meanest sort brought us such dainties as they had, and of their bread which they made of their maize or Gennea wheat. (p. 11)

We found store of turkey nests and many eggs. (p. 15)

I saw bread made by their [Indian] women, which do all their drudgery. . . . The manner of baking bread is thus:—after they pound their wheat into flour with hot water, they make it into paste, and work it into round balls and cakes; then they put it into a pot of seething [boiling] water. When it is sod [cooked] throughly, they lay it on a smooth stone; there they harden it as well as in an oven. (p. 21)

Our food was but a small can of barley, sod in water, to five men a day, our drink, cold water taken out of the river, which was at a flood [high tide] very salt, at a low tide full of slime and filth, which was the destruction of many of our men. (p. 26)

It pleased God, after a while, to send those people which were our mortal enemies to relieve us with victuals, as bread, corn, fish and flesh in great plenty. . . . (p. 26)

[Quotation from 17 August 1611 letter from Percy to his brother:]

True it is the place which I hold in this colony (the store affording no other means than a pound of meal a day and a little oatmeal) cannot be defrayed with small expense, it standing upon my reputation (being Governor of Jamestown) to keep a continual and daily table for gentlemen of fashion about me. (p. ix)

[1607].

Gabriel Archer. "The Discription of the now discovered River and Country of Virginia; with the Liklyhood of ensuing ritches, by Englands ayd and industry." In *The Extension of Settlement in Florida, Virginia, and the Spanish Southwest*. Ed. David B. Quinn. Vol. 5 of *New American World: A Documentary History of North America to 1612*. New York: Arno Press, 1979.

The mayne river aboundes with Sturgeon very large and excellent good: having also at the mouth of every brook and in every creek both store and exceeding good fish of divers kindes, and in [the] large soundes neere the sea are multitudes of fish, bankes of oysters, and many great crabbs rather better in tast then ours, one able to suffice 4 men: And within sight of land into the sea we expect at tyme of yeare to have a good fishing for codd. . . . (p. 274)

It produceth of one corne of that Country wheate sometymes two or three stemnes or stalkes on which grow eares above a spann longe. besett with cornes at the least 300 upon an eare for the most part 5, 6, & 700. the beanes and peaz of this Country have a great increase also: It yeelds two cropps a yeare. . . . from the west Indies we brought a certeine delicious fruite called a pina, which the Spanyard by all art possible could never procure to grow in any place, but in his naturall site, this we rudely and carelessly sett in our mould, which

fostereth it and keepes it greene, and to what Issue it may come I know not, our west Indy plantes of orenge & Cotten trees thrive well, likewise the potatoes pumpions & mellions: All our garden seedes, that were carefully sowne prosper well, yet we only digged the ground half a [foot?] deep threw in the seedes at randome carelessly and scarce rakt it. It naturally yeelds mulbery trees, Cherry trees, vines abundance, goosberyes, strawberyes, hurtleberyes, Respesses, ground nuttes, scarrettes, the roote called sigilla Christi, certaine sweet thynn shelled nuttes, certaine ground aples, a pleasant fruite and many other unknown. (p. 275)

1607.

[Gabriel Archer.] "A relayton of the Discovery, &c. 21 May—22 June 1607." In *Travels and Works of Captain John Smith*. Ed. Edward Arber and A. G. Bradley. Vol. 1. Edinburgh: John Grant, 1910.

Sunday, Whitsonday, our Captayne [Smith] caused two peeces of porke to be sodd a shore with pease; to which he invyted king *Pawatah*. . . .

Now *Arahetec* departed, and it being Dynner tyme, king *Pawatah* with some of his people satt with us, brought of his dyet, and we fedd familiarly, without sitting in his state as before; he eat very freshly of our meat, Dranck of our beere, Aquavite, and Sack. (p. xlv)

[Powhatan] sent for another Deere which was roasted and after sodd for us (as before) Our Captayne caused his Dynner to be Dressed a shore also. Thus we satt banquetting all the forenoone. [S]ome of his people led us to their houses, shewed us the growing of their Corne and the maner of setting it, gave us Tobacco, wallnutes, mulberyes, strawberyes, and Respises. One shewed us the herbe called in their tongue *wisacan*, which they say heales poysoned woundes, it is like lyverwort or bloudwort. . . .

At Dynner our Captayne gave the kyng a glasse and some Aquavitae therin, shewing him the benefytt of the water, for which he thanckt him kindly: and taking our Leave of him, he promised to meete us at a point not farr of: where he hath another house, which he performed withall, sending men into the woodes to kill a Dere for us if they could. This place I call *mulbery shade*. He caused heere to be prepared for us *pegatewk-Apyan* which is bread of their wheat made in Rolles and Cakes; this the weomen make, and are very clenly about it; we had parched meale, excellent good; sodd beanes, which eate as

sweete as filbert kernells in a maner, strawberryes and mulberryes new shaken of the tree dropping on our heads as we satt: He made ready a land turtle which we eate, and shewed that he was hartely rejoyced in our Company. . . . Here we came within night, yet was there ready for us of bread new made, sodden wheate and beanes, mullberryes, and some fishe undressed more then all we could eate. (pp. xlviiii-xlix)

1607.

"Coppie of a Letter from Virginia, Dated 22d of June, 1607. The Councell there to the Councell of Virginia here in England." In *The Genesis of the United States: A Narrative of the Movement in England, 1605-1616*. Ed. Alexander Brown. Vol. I. 1890; rpt. New York: Russell and Russell, 1964.

Our easiest and richest comodity being Sasafriz roots were gathered up by the Sailors with loss and spoil of many of our tools and with drawing of our men from our labour. . . . [Editor's note: The East India Company and others making long voyages used sassafras root and anise-seed for making a beverage, which was thought to be "very wholesome for the preservation of men's health" on board the ships.] (p. 107)

1607-1612.

John Smith. "The Proceedings of the English colony in Virginia." In *The Extension of Settlement in Florida, Virginia, and the Spanish Southwest*. Vol. 5 of *New American World: A Documentary History of North America to 1612*. Ed. David B. Quinn. New York: Arno Press, 1979.

Being thus left to our fortunes, it fortuned that within tenne daies scarce ten amongst us coulde either goe, or well stand, such extreame weaknes and sicknes opressed us. And thereat none need marvaile, if they consider the cause and reason, which was this; whilst the ships staied, our allowance was somewhat bettered, by a daily proportion of bisket which the sailers would pilfer to sell, give or exchange with us, for mony, saxefras, furies, or love. But when they departed, there remained neither taverne, beere-house nor place of relief but the common kettell. Had we beene as free from all sinnes as gluttony, and drunkennes, we might have bin canonized for Saints; But our President would never have bin admitted, for ingrossing to his privat, Otemeale, sacke, oile, aquavite, beefe eggs, or what not, but the kettel; that indeede he allowed equally to be distributed, and that was halfe a pinte of wheat and as much barly boyled with water for a

man a day, and this having fryed some 26. weeks in the ships hold, contained as many wormes as graines; so that we might truly call it rather so much bran then corne, our drinke was water, our lodgings castles in aire. . . . From May to September, those that escaped; lived upon Sturgion, and sea-Crabs. . . . (p. 313)

And now the winter approaching, the rivers became so covered with swans, geese, duckes, & cranes, that we daily feasted with good bread, Virginia pease, pumpions, and putchamins, fish, fowle, and diverse sorts of wild beasts as fat as we could eat them. . . . (p. 314)

This hapned in the winter, in that extreame frost, 1607. Now though we had victuall sufficient, I meane only of Oatemeale, meale, and corne yet the ship staying there 14. weeks when shee might as well have been gone in 14. daies, spent the beefe, porke, oile, aquavite, fish, butter, and cheese, beere and such like; as was provided to be landed us. When they departed, what their discretion could spare us, to make a feast or two with bisket, pork beefe, fish, and oile . . . of each somewhat they left us. . . . For all this plentie our ordinarie was but meale and water. . . . (pp. 316-17)

. . . in diverse places that abundance of fish lying so thicke with their heads above the water, as for want of nets (our barge driving amongst them) we attempted to catch them with a frying pan, but we found it a bad instrument to catch fish with. (p. 321)

The next night being lodged at Kecoughtan 6 or 7 daies [in December 1608], the extreame wind, frost, and snowe, caused us to keepe Christmas amongst the Salvages, where wee were never more merrie, nor fedde on more plentie of good oysters, fish, flesh, wildfoule, and good bread, nor never had better fires in England then in the drie warme smokie houses of Kecoughtan. (pp. 328-29)

. . . we sent to Powhatan for provision, who sent us plentie of bread, Turkies, & Venison. . . . the king concluded the matter with a merry laughter, asking for our commodities, . . . valuing a basket of corne more pretious then a basket of copper, saying he could eate his corne, but not his copper. (p. 329)

. . . of 3 sowes in one yeare increased 60 and od pigges, and neere 500 chickens brought up themselves (without

having any meate given them). . . . Untill this time Kemp and Tassore, were fettered prisoners, and daily wrought, and taught us how to order and plant our fields. Whome now (for want of victuall) we set at libertie, but so wel were they used, that they little desired it; and to express their loves, for 16 daies continuance, the Countrey brought us (when least) 100 a daie of squirrils, Turkies, Deare, and other wild beastes; but this want of corne occasioned the end of all our workes, it being worke sufficient to provide victuall. 60 or 80 with Ensigne Laxon were sent downe the river to live upon oysters, & 20 with leiftenant Percie to trie for fishing at Point-Comfort, but in 6 weekes, they would not agree once to cast out their net. Master West with as many went up to the falles, but nothing could be found but a few berries and acornes. . . . Wee had more Sturgeon then could be devoured by dogge and man; of which the industrious, by drying and pouncing, mingled with caviare, sorrel, and other wholesome hearbs, would make bread and good meate; others would gather as much Tockwough roots in a day, as would make them bread a weeke, so that of those wilde fruites, fish and berries, these lived very well, (in regard of such a diet) but such was the most strange condition of some 150, that had they not beene forced nolens volens perforce to gather and prepare their victuall they would all have starved, and have eaten one another: of those wild fruites the Salvages often brought us. . . . (p. 338)

[1607 to 1608].

"Edward Maria Wingfield's replies to the charges made against him in Virginia." In *The Extension of Settlement in Florida, Virginia, and the Spanish Southwest*. Ed. David B. Quinn. Vol. 5 of *New American World: A Documentary History of North America to 1612*. New York: Arno Press, 1979.

It was then therefore ordered, that every meale of fish or fleshe should excuse the allowance for poridg, both against the sick and hole. (p. 278)

Now was the Comon store of oyle, vinigar, sack, & Aquavite all spent saveing twoe Gallons of each; the sack reserved for the Comunion table, the rest for such extremityes as might fall upon us. . . . (p. 278)

First Master President said that I had denyed him a penny whitle, a Chickyn, a spoonfull of beere, and served him with foule Corne. . . .

Master Martyn followed with, he reported that I doe slack the service in the Collonye, and doe nothing but tend my pott, spitt, and oven. . . . (pp. 279-80)

. . . [Master Archer] had bought some Witnesses handes against me to divers artycles with Indian Cakes. . . . (p. 280)

As I understand by report I ame much charged with starving the Collony; I did allways give every man his allowance faithfully, both of Corne, oyle, aquivite &c as was by the Counsell proportioned, neyther was it bettered after my tyme, untill towards th'end of March, a Bisket was allowed to every workeing man for his breakefast, by meanes of the provision brought us by Captayn Newport, as will appeere here after: It is further said I did much banquit, and Ryot: I never had but one Squirell roasted, whereof I gave part to Master Ratcliff then sick; yet was that Squirell given me; I did never heate a flesh pott, but when the Comon pot was so used likewise; Yet how often Master Presidentes and the Councillors spittes have night & daie bene endangered to break their backes so laden with swanns, geese, duckes, &c, how many tymes their flesh pottes have swelled, many hungry eies did behold to their great longing: and what great Theeves, and theeving thear hath bene in the Comon stoare since my tyme. . . . (p. 281)

. . . many bookes in my house . . . were sent me up in a Trunk to London, with divers fruite, conserves, & preserves, which I did sett in Master Crofts his house in Ratcliff; In my beeing at Virginia I did understand my trunck was thear broken up, much of my sweete meates eaten at his Table. . . . (p. 283)

. . . 2 glasses with sallet oyle which I brought with me out of England for my private stoare. . . . (p. 283)

Master Smyth in the tyme of our hungar had spred a Rumor in the Collony that I did feast my self and my servauntes, out of the Comon stoare. . . . I tould him privately in Master Gosnolds Tent, that indeede I had caused half a pinte of pease to be sodden, with a peese of porke of my owne provision for a poore old man. . . . (p. 284)

1608.

Excerpt from a letter [from Francis Perkins?]. In *The Genesis of the United States: A Narrative of the Movement in England,*

1605-1616. Ed. Alexander Brown. Vol I. 1890; rpt. New York: Russell and Russell, 1964.

The [James] river is very beautiful and wide, but full of shallows and piles of oystershells. The land lies low and is full of wood until you reach the coast. [At first] we always had warm weather; afterwards such bitter colds and such severe frosts that I and several others had our feet frost bitten. A month after this we came to a land where there was also great frost and snow. . . . So excessive are the frosts, that one night the river froze over almost from bank to bank, in front of our harbour, although it was there as wide as that of London. There died from the [ice/frost] some fish in the river, which when taken out after the [ice/frost] was over, were very good and so fat that they could be fried in their own fat without adding any butter or such thing. (p. 175)

1609.

Virginia Council. "Instruccions Orders and Constitucions . . . to Sr Thomas Gates Knight Governor of Virginia." In *The Three Charters of the Virginia Company of London with Seven Related Documents; 1606-1621*. Williamsburg: Virginia 350th Anniversary Celebration Corporation, 1957, pp. 55-69.

You shall, for the choice of plantacions observe two general rullles: that you rather seeke to the sun then from it, which is under God the first cause both of health and riches; and that such places which you resolve to build and inhabite uppon have at the leaste one good outlett into the sea & fresh water to the land; that it be a dry and wholesome earth and as free from woode as possiblie you may, whereby you may have roome to discover about you and unshady ground to plant nere you.

You must in every plantacion principally provide of your owne a common graunge and storehowse of corne, besides that which you will obtaine by tribute or trade with the natives. (p. 59)

. . . you must, by proclamacion or edicte publicquely affixed, prohibite and forbidd uppon paine or punishement of your discrecion all other persons to trade or exchange for anythinge but such as shalbe necessarie for foode or clothinge. . . . (p. 64)

For such of your men as shall attend any worke in or nere aboute every towne, you shall doe best to lett them eate together at seasonable howers in some publique place,

being messed by sixe or five to a messe, in which you must see there bee equality and sufficient that so they may come and retourne to their worke without any delay and have no cause to complaine of measure or to excuse their idlenes upon the dressinge or want of diett. You may well allowe them three howers in a somers day and two in the winter, and shall call them together by ringinge of a bell and by the same worne them againe to worke; for such as attend any labourer so farre from the forte, as they cannot returne at seasonable times, there must be a steward appointed that shall oversee there diett and provision, els thoughe you give every one a reasonalbe allowance for many dayes some will eate two meals at one. . . . (p. 65)

1609.

Robert Johnson. "Nova Britannia: offering most excellent fruites by planting in Virginia. Exciting all such as are well affected to further the same." *The Extension of Settlement in Florida, Virginia, and the Spanish Southwest*. Ed. David B. Quinn. Vol. 5 of *New American World: A Documentary History of North America to 1612*. New York: Arno Press, 1979.

Wee intend to plant there (God willing) great plentie of Sugar Canes, for which the soyle and clymate is very apt and fit; also Linseed, and Rapeseeds to make Oiles, which because the soyle is strong and cheape, may there be sowed and the oyle made to great benefite: wee must plant also Orenge, Limons, Almonds, Anniseeds, Rice, Cummin, Cotton wool, Carowey seeds, Ginger, Madder, Olives, Oris, Sumacke, and many such like, which I cannot now name. . . . (p. 244)

1610.

"Copy of a document indorsed on the outside: 'July 1, 1610. Report on Virginia to the [Spanish] council of state.'" In *The Genesis of the United States: A Narrative of the Movement in England, 1605-1616*. Ed. Alexander Brown. Vol. I. 1890; rpt. New York: Russell and Russell, 1964.

There are in those rivers great numbers of salmons [sallos.] and other fish, and such a quantity of Codfish and as good as in Newfoundland. There is in that country an infinite supply of deer, peacock, swans and every kind of fowl. There grow in that country wild many forest grapes, of which the English make a wine that resembles much the wine of Alicante, according to the opinion of the narrator who has tasted both. There is also a great quantity of [hanas], chick-pea, maize, almonds, nuts and chesnuts. . . . (p. 395)

1610.

Councell of Virginia. "A True Declaration of the estate of the Colonie in Virginia, With a confutation of such scandalous reports as have tended to the disgrace of so worthy an enterprise." In *Tracts and Other Papers, relating principally to the Origin, Settlement, and Progress of the Colonies in North America, from the discovery of the country to the year 1776*. Ed. Peter Force. Vol. III, No. 1. 1844; rpt. New York: Peter Smith, 1947.

To begin, with the staffe of bread. It is avowed unto mee, in writing, in the words of the Author, that hath been there, as followeth. *They use to put their wheat into the ground, five cornes in one spit of earth, and two beanes with them: which wheat cornes multiplying into divers stalks, grow up twelve, or fourteene foote high: yeelding some foure, five, or six eares, on every stalke; and in every eare, some five hundred, some six hundred, some seaven hundred cornes: the two beanes, runne upon the stalkes of the wheat, as our garden pease upon stickes, which multiplie to a wonderous increase. I cannot let slip a great secret, (saith the Author) whereof I will avouch no more, then with my hands and eyes I have handled and seene, and whereof to my great comfort, I have often tasted: The wheate beeing sowed thicke, some stalkes beare eares of corne, and some (like siences in trees) beare none: but in those barren stalkes, there is as much juice as in some sugar cane, of so delicate a tast, as no fruit in England, is comparable to it; out of which Sir Ralph Lane conceived, that wee may extract sugar, in great quantity. But Sir Thomas Gates affirmeth that our men doe make cordiall drinke thereof, to their great comfort.*

Besides, the naturall Pease of the Countrie returne an increase innumerable, our garden fruits, both roots, hearbes, and flowers, doe spring up speedily, all things committed to the earth, do multiply with an incredible usurie. (p. 12)

. . . Lastly, infinite store have been presented to *Captaine Newport* upon sundry occurrents: such a plentie of Cattell, as all the Spaniards found not in the whole kingdome of *Mexico*, when all their presents were but hennes, and ginycocks, and the bread of Maize, and Cently.

There are *Arocouns*, and *Apossouns*, in shape like to pigges, shrowded in hollow roots of trees; There are Hares and Conies, and other beasts proper to the Countrie in plentifull manner.

Our transported Cattell, as Horses, Kine, Hogs, and Goats, do thrive most happily: which is confirmed by a double experiment; one of *Sir Ralph Lane*, who brought Kine from the West Indian Island; the other of our Colony, who need take no other care of them, but least they should straine too farre, or be stolne from them. The Turkyes of that Countrie are great, and fat, and exceeding in plentie. The rivers from August, or September, till February, are covered with flocks of Wildfoule: as swannes, geese, ducke, mallard, teal, wigeons, hearons, bitters, curlewes, godwights, plovers, snights, dottrels, cormerants (to use the words of *Sir Thomas Gates*) in such abundance as are not in all the world to be equalled.

The Fruits: as apples, running on the ground, in bignesse and shape of a small lemmon, in colour and tast like to a preserved Apricock: grapes and walnuts innumerable; the vines being as common as brambles, the walnut trees as the elmes in England. What should I speake of cucumbers, muske melons, pompions, potatoes, parsneps, carrets, turnups, which our gardens yeilded with little art and labour. God in this place is ever concurring with his gracious influence, if man strangle not his blessings, with carelesse negligence. (p. 13)

1610.

"Instructions for such things as are to be sente from Virginia. 1610." In *The Genesis of the United States: A Narrative of the Movement in England, 1606-1616*. Ed. Alexander Brown. Vol I. 1890; rpt. New York: Russell and Russell, 1964.

1. Small Sassafras rootes to be drawn in the winter and dryed and none to be medled with in the Sommer. . . . (p. 384)

4. Galbrand groweth like fennell in fashion, and there is greatest stoare of it in Warriscoes Country, where they cut walnut tree laste. You must cut it downe in Maye or June, and beinge downe it is to be cut into small peeces, and brused and pressed in your small presses which were sent over for oyle, or any other like presses, the juice thereof is to be saved and put into casks. . . .

5. Sarsapilla is a Roote that runneth within the grounde like unto Licoras, which beareth a small rounde leafe close by the grounde, which beinge founde the Roote is to be pulled up and dryed and bounde up in bundles like Faggotts, this to be done toward the ende of Sommer before the leafe fall from the stalk. . . .

6. Wallnutt oyle is worth here £30. per Tonne, and the like is chesnutt oyle and chechinkamyne oyle.

7. Wyne a hoggeshead or two sower as it is, should be sent for a sample, and some of the grapes packed in Sande. (p. 385)

14. Sturgion which was last sent, came ill conditioned, not beinge well boyled, if it were cut in small peeces, and powdred put up in caske, the heads pickled by themselves, and sente hither it would doe farre better.

15. Rowes of the said Sturgion make Cavearie according to instructions formerlye given.

16. Soundes of the said Sturgion will make Isinglasse according to the same instructions. (p. 386)

1610.

Silvester Jourdain. "A Discovery of the Bermudas, Otherwise Called the Isle of Devils" (1610). In *A Voyage to Virginia in 1609: Two Narratives, Strachey's "True Reportory," Jourdain's "Discovery of the Bermudas."* Ed. Louis B. Wright. Charlottesville: Univ. Press of Virginia, 1964.

There is fowl in great num[ber] upon the [Bermuda] islands where they breed, that there hath been taken in two or three hours a thousand at the least, the bird being of the bigness of a good pigeon and layeth eggs as big as hen eggs upon the sand, where they come and lay them daily although men sit amongst them, that there hath been taken up in one morning by Sir Thomas Gates's men one thousand of eggs; and Sir George Somers' men, coming a little distance of time after them, have stayed there whilst they came and laid their eggs amongst them, that they brought away as many more with them, with many young birds very fat and sweet. (pp. 110-11)

There are also great store of tortoises (which some call turtles) and those so great that I have seen a bushel of eggs in one of their bellies, which are sweeter than any hen egg; and the tortoise itself is all very good meat and yieldeth great store of oil, which is as sweet as any butter; and one of them will suffice fifty men a meal, at the least. . . . (p. 111)

. . . we prepared and made ourselves ready to ship for Virginia, having powdered [salted] some store of hogs' flesh for provision thither and the company thereof for some reasonable time but were compelled to make salt there for the same purpose, for all our salt was spent and spoiled before we recovered the shore. We carried with

us also a good portion of tortoise oil, which either for frying or baking did us very great pleasure, it being very sweet, nourishing, and wholesome. (p. 114)

1610.

William Strachey. "A True Reportory of the Wreck and Redemption of Sir Thomas Gates, Knight, upon and from the Islands of the Bermudas: His Coming to Virginia and the Estate of the Colony Then and After, under the Government of the Lord La Warr, July 15, 1610." In *A Voyage to Virginia in 1609: Two Narratives, Strachey's "True Reportory," Jourdain's "Discovery of the Bermudas."* Ed. Louis B. Wright. Charlottesville: Univ. Press of Virginia, 1964.

[In the storm we] staved many a butt of beer, hogsheds of oil, cider, wine, and vinegar. . . . (p. 14)

[On Bermuda] Somers in the beginning of August squared out a garden by the quarter . . . and sowed muskmelons, peas, onions, radish, lettuce, and many English seeds and kitchen herbs. (p. 23)

. . . our governor dried and salted [many kinds of fish] and, barreling them up, brought to sea five hundred; for he had procured salt to be made with some brine which happily was preserved, and, once having made a little quantity, he kept three or four pots boiling and two or three men attending nothing else in an house. . . . (p. 28)

We had knowledge that there were wild hogs [on Bermuda], at first by our own swine preserved from the wreck and brought to shore; for they straying into the woods, an huge wild boar followed down to our quarter, which at night was watched and taken in this sort. One of Sir George Somers' men went and lay among the swine, when, the boar being come and groveled by the sows, he put over his hand and rubbed the side gently of the boar, which then lay still; by which means he fastened a rope with a sliding knot to the hinder leg and so took him, and after him in this sort two or three more. (p. 32)

. . . then the tortoises came in again, of which we daily both turned up great store, finding them on land, as also, sculling after them in our boat, stuck them with an iron goad and sod, baked, and roasted them. The tortoise is reasonable toothsome (some say), wholesome meat. I am sure our company liked the meat of them well, and one tortoise would go further amongst them than three hogs.

One turtle (for so we called them), feasted well a dozen messes, appointing six to every mess. It is such a kind of meat as a man can neither absolutely call fish nor flesh, keeping mostwhat in the water and feeding upon sea grass like a heifer in the bottom of the coves and bays . . . the Spanish friars (at their first arrival) make some scruple to eat them on a Friday, because in color and taste the flesh is like to morsels of veal. (p. 33-34)

[In Virginia] no country yieldeth goodlier corn nor more manifold increase. Large fields we have, as prospects of the same, and not far from our palisade. Besides, we have thousands of goodly vines in every hedge and bosk, running along the ground, which yield a plentiful grape in their kind. Let me appeal, then, to knowledge, if these natural vines were planted, dressed, and ordered by skillful *vignerons*, whether we might not make a perfect grape and fruitful vintage in short time. And we have made trial of our own English seeds, kitchen herbs, and roots and find them to prosper as speedily as in England. (p. 68)

. . . so had our men abased and to such a contempt had they brought the value of our copper [in trading with the Indians] that a piece which would have bought a bushel of their corn in former time would not now buy a little cade or basket of a pottle [a measure equivalent to half a gallon]. And for this misgovernment chiefly our colony is much bound to the mariners, who never yet in any voyage hither but have made a prey of our poor people in want; insomuch as unless they might advance four or five for one (how assured soever of the payments of their bills of exchange) they would not spare them a dust [grain] of corn nor a pint of beer to give unto them the least comfort or relief, although that beer purloined and stolen perhaps, either from some particular supply or from the general store. . . . (p. 71-72)

[The lord governor and captain general] would have a commissary general of the victuals to be appointed, who (receiving the store for the colony, by indenture from the treasurer and victualers in England) may keep a just accompt what the gross amounteth unto and what is transported every voyage, in several kinds, as of bread, meat, beer, wine, etc. . . . (pp. 73-74)

[In the Jamestown fort when food was scarce] their best relief was only mushrooms and some herbs which, sod together, made but a thin and unsavory broth and swelled them much. (p. 75)

In the midst [of the Jamestown fort] is a market place, a store-house, and a *corps de garde*. . . . (p. 79)

. . . I may not excuse this our fort, or Jamestown, as yet seated in somewhat an unwholesome and sickly air, by reason it is in a marish [marshy] ground, low, flat to the river, and hath no fresh-water springs serving the town but what we drew from a well six or seven fathom deep, fed by the brackish river oozing into it; from whence I verily believe the chief causes have proceeded of many diseases and sicknesses which have happened to our people, who are indeed strangely afflicted with fluxes and agues, and every particular infirmity too: all which, if it had been our fortunes to have seated upon some hill, accommodated with fresh springs and clear air, as do the natives of the country, we might have, I believe, well escaped. (pp. 82-83)

The first business which the lord governor and captain general . . . thought upon was to advise with his council for the obtaining of such provisions of victuals for store and quality as the country afforded. It did not appear that any kind of flesh, deer, or what else of that kind could be recovered from the Indian or to be sought in the country by the travail or search of his people and the old dwellers in the fort (together with the Indians not to friend), who had the last winter destroyed and killed up all the hogs, insomuch as of five or six hundred (as it is supposed) there was not one left alive; nor an hen nor chick in the fort; and our horses and mares they had eaten with the first. . . . (p. 86)

. . . to clear all doubts [pertaining to the story of the man who killed and salted his wife], Sir Thomas Gates thus relateth the tragedy.

'There was one of the company who mortally hated his wife and therefore secretly killed her, then cut her in pieces and hid her in divers parts of his house. When the woman was missing, the man [was] suspected, his house searched, and parts of her mangled body were discovered. To excuse himself he said that his wife died, that he hid her to satisfy his hunger, and that he fed daily upon her. Upon this, his house was again searched, where they found a good quantity of meal, oatmeal, beans, and peas. He thereupon was arraigned, confessed the murder, and was burned for his horrible villainy.' (p. 98)

. . . there is great store of fish in the river, especially of sturgeon, but our men provided no more of them than for present necessity, not barreling up any store against that season the sturgeon returned to the sea. And not to dissemble their folly, they suffered fourteen nets (which was all they had) to rot and spoil. . . . (pp. 98-99)

. . . lemons, sugar canes, almonds, rice, aniseed, and all commodities which we have from the Straits, may be supplied to us in our own country and by our own industry. . . . (p. 101)

1610-1612.

William Strachey. "Historie of Travaile into Virginia Britannia." In *The Extension of Settlement in Florida, Virginia, and the Spanish Southwest*. Vol. 5 of *New American World: A Documentary History of North America to 1612*. Ed. David B. Quinn. New York: Arno Press, 1979.

The natives have here a kinde of wheat which they call poketawes, as the West Indians call the same maiz. The forme of yt is of a man's tooth, somewhat thicker. . . . the stalk being greene hath a sweet juyce in yt, somewhat like a sugar-cane, which is the cause that when they gather the corne greene, they suck the stalkes, for as we gather greene peas, so do they, their corne being greene, which excelleth their old.

Peas they have, which the natives call assentemmens, and are the same which in Italy they call fagioli.

Their beanes are little like a French beane, and are the same which the Turks call garvances, and these kind of pulse they much esteeme for daynties. . . .

In some places we fynd chestnutts, whose wild fruit I maie well saie equallize the best in Fraunce, Spaine, Germany, Italy, or those so commended in the Black sea, by Constantinople, of all which I have eaten.

They have a small fruit growing in little trees, husked like a chestnut, but the fruit most like a very small acron, this they call chechniquamins, and these, with chesnutts, they boile four or five houres, of which they make both broth and bread, for their chief men, or at their greatest feasts.

They have cherries much like a damoizin, but for their tast and cullour we called them cherries; and a plomb there is, somewhat fairer then a cherrie, of the same relish, then which are seldome a better eaten.

They have a berry much like our goose-berries in greatness, cullour, and tast, these they call rawcomenes, and they doe eate them rawe or boyled.

In the watry valleis groweth a berry which they call ooughtanamins, very much like unto capers; these they gather and dry in the heat of the sun, and when they will eate them, they boyle them nere halfe a daie, for otherwise they differ not much from poison.

Nattourne groweth as our bents doe in meadowes, the seed is not much unlike to rie, though much smaller; these they use for a deyntie bread, buttered with deare's suett.

They have a plomb which they call pessemmins, like to a medler, in England, but of a deeper tawnie cullour; they grow on a most high tree. When they are not fully ripe, they are harsh and choakie, and furre in a man's mouth like allam, howbeit, being taken fully ripe, yt is a reasonable pleasant fruict, somewhat lushious. I have seene our people put them into their baked and sodden puddings; there be whose taste allowes them to be as pretious as the English apricock; I confesse it is a good kind of horse plomb.

Here is a cherry-redd fruict both within and without (as I have seene the like in the Bermudas), which wee call the prickle peare; in the Indies they are well knowne to every common marryner; they beare a broad, thick, spongeous leafe, full of kernells; they be like the pomegranet; the tast of this peare is verie pleasant, and the juyce cold and fresh, like the water in the West Indian nut called cocus; the juyce is sharpe and penetrable like deale-wyne, prescribed powerfull against the stone.

Here is a fruict by the naturalls called a maracock; this groweth generally low, and creepeth in a manner amongst the corne (albeit I have seene yt, planted in a gardein within our fort, at James Towne, to spred and rise as high as the pale); yt is of the bignes of a queen apple, and hath manie azurine or blew karnells, like as a pomegranet, and yt bloometh a most sweet and delicate flower, and yt is a good sommer cooling fruict, and in every field where the Indians plant their corne be cart-loads of them.

The macokos is of the forme of our pumpeons,—I must confesse, nothing so good,—'tis of a more waterish tast; the inhabitants seeth a kind of million, which they put into their walnut-milke, and so make a kynd of toothsome meat.

In Aprill, Maie, and June, are great store of strawberries, raspices, hurts, etc., and many hearbs in the spring time are comonly dispersed throughout the woodes, good for broathes and sallotts, as violetts, purselin, sorrell, and roses, in their season, etc., besides many we used whose names we knowe not. . . .

Twenty gallons [of wine] at a tyme have bene sometimes made without any other helpe then by crushing the grape with the hand, which letting to settle five or six daies, hath, in the drawing forth, proved strong and headdy. Unto what perfection might not these be brought by the art and industry of many skilful *vineroones*, being thus naturally good? . . .

Many rootes the Indians have here likewise for food. The chief they call tockowhough and yt groweth like a flag in low muddy freshes; in one day a salvadge will gather sufficient for a weeke: these rootes are much of the greatnes and tast of potatoes. They use to rake up a great number of them in old leaves and ferne, and then cover all with earth or sand, in the manner of a coal-pit; on each side they contynue a great fier a daie and a night before they dare eate yt: rawe, yt is no better then poison, and being roasted (except yt be tender and the heat abated, or sliced and dryed in the sun, mixed with sorrell and meale, or such like), yt will prickle and torment the throat extreamely, and yet in sommer they use this ordinarily for bread. (pp. 352-54)

In the low marishes grow plotts of onions conteyning an acre of ground or more in manie places, but they are small, like the chiballs, or schallions, not past the bignes of the toppe of one's thumb: they eat well sod or otherwise in sallet or in bakt meats. Our people find good and wholsome relish in them; howbeit the inhabitants cannot abyde to eate of them; and these onions doe for the most part appeare in the last season of the yeare. . . .

There is a beast they call arocoune. . . . Excellent meate we kill often of them. . . .

An opposum . . . eates in tast like a pig.

Muscascus is a beast black in cullour, proportioned like a water ratt; he hath a cod within him, which yieldeth a strong sent, like unto musk; yt is a good meat if the cod be taken out, otherwise the flesh will tast most strong and ranck of the musk; so will the broath wherein yt is sod. . . .

Beares there be manie towardes the sea-coast, which the Indians hunt most greedily; for indeed they love them above all other their flesh, and therefore hardly sell any of them unto us, unles upon large proffers of copper, beads, and hatchetts. We have eaten of them, and they are very toothsome sweet venison, as good to be eaten as the flesh of a calfe of two yeares old. . . .

The beaver there is as big as an ordinary water dog, . . . his tayle somewhat like the forme of a rackett,

bare, without haire, which, to eate, the salvages esteeme a great delicate.

Otters there be manie. . . . of all these beasts [the Indians] use to feed when they catch them. (pp. 354-55)

Turkeys there be great store, wild in the woods, like phesents in England, forty in a company, as big as our tame bere, and yt is an excellent fowle, and so passing good meate as I maye well saie, yt is the best of any kind of flesh which I have ever yet eaten there. (p. 355)

To the naturall commodities which the countrie hath of fruits, beasts, and fowle, we maie also adde the no meane commoditie of fish, of which, in March and Aprill, are great shoells of herrings.

Sturgeon, great store, commonlie in Maie if the yeare be forward. . . .

Shaddes, great store, of a yard long, and for sweetnes and fatnes a reasonable good fish, he is only full of small bones, like our barbells in England. . . .

Oysters there be in whole bancks and bedds, and those of the best: I have seene some thirteen inches long. The salvages use to boyle oysters and mussells together, and with the broath they make a good spoone meat, thickned with the flower of their wheat; and yt is a great thrift and husbandry with them to hang the oysters upon strings (being shauld and dried) in the smoake, thereby to preserve them all the yeare. . . .

There is a kind of shelfish of the proporcion of a cocke, but far greater, yt hath a smooth shell, not ragged as our cockles; 'tis good meat, though somewhat tough.

Tortoyses here (such as in the Bermudas) I have seene about the entrance of our bay, but we have not taken of them, but of the land tortoyses we take and eate dailie. . . . (p. 356)

[Of the oak] there is two or three severall kyndes, the acrons of one kind, whose barke is more white then the other, is somewhat sweetish, which, being boyled halfe a daie in severall waters, at last affordes a sweet oyle, which they call monohomy: they keepe yt in gourdes to annoint their heads and joynts; the fruict they eate made in bread or otherwise. . . .

Of walnutts there be three kindes. . . . The third sort is . . . exceeding hard shelled, and hath a passing sweet karnell; this last kind the Indians beat into pieces with stones, and putting them, shells and all, into morters, mingling water with them, with long wooden pestells pound them so long together untill they make a kind of

mylke, or oylie liquor, which they call powcohicora. (pp. 356-57)

By the dwellings of the salvages are bay-trees. . . .

Crabb trees there be, but the fruict small and bitter, howbeit, being graffed upon, soone might we have of our owne apples of any kind, peares, and what ells. (p. 357)

1611.

"Dale to the Council." In *The Genesis of the United States: A Narrative of the Movement in England, 1605-1616*. Ed. Alexander Brown. Vol I. 1890; rpt. New York: Russell and Russell, 1964.

I found here likewise no corn sett, some few seeds put into a private garden or Two; but the cattle, cows, goats, swine, Poultry &c to be well and carefully on all hands preserved and all in good plight and likeing. . . . Brick to be made, a sturgion house, which the late curer, you sent by the Hercules, much complayneth of, his work otherwise impossible to come to good, and indeed he dresseth the same sturgions perfect and well, a Block house to be raised on the North side of our back River to prevent the Indians from killing our cattle, a house to be set up to lodge our cattle in the winter, and hay to be appointed in his due time to be made, a smith's forge to be perfected—Caske for our Sturgions to be made, and besides private gardens for each man. . . . (pp. 491-92)

1611.

"De la Warr's Relation." In *The Genesis of the United States: A Narrative of the Movement in England, 1605-1616*. Ed. Alexander Brown. Vol I. 1890; rpt. New York: Russell and Russell, 1964.

. . . I found help for my health, and my sicknesse assuaged, by meanes of fresh diet, and especially of Orenge and Lemonds. . . . (p. 480)

The countrey is wonderfull fertile and very rich, and makes good whatsoever heretofore hath beene reported of it, the Cattell already there, are much encreased, and thrive exceedingly with the pasture of that Countrey: The kine all this last Winter, though the ground was covered most with snow, and the season sharpe, lived without other feeding than the grasse they found, with which they prospered well, and many of them readie to fall with Calve; Milke being a great nourishment and refreshing to our people, serving also in (occasion) as

well for physicke as for Food, so that it is no way to be doubted, but when it shall please God that Sir Thomas Dale, and Sir Thomas Gates, shall arrive in Virginia with their extraordinary supply of one hundred Kine, and two hundred Swine, besides store of all manner of other provisions for the sustenance and maintenance of the Collony. . . . (pp. 481-82)

1612.

Robert Johnson. *The New Life of Virginea*. London, 1612; rpt. Amsterdam: Theatrum Orbis Terrarum Ltd.; New York: Da Capo Press, 1971.

. . . they built a Church and many houses together, which they named *James Towne*, they nourished their swine, hens, and other provisions they caried out of England, which plentifully encreased: . . . they planted orange trees, corne, and sundrie kindes of seeds, they made Sope ashes and Tar, with some Sturgeon and Caveare, and of each of these they sent us small quantities, with store of Sassafrasse, and some wine of those countrie grapes for a triall. . . . [pp. 10-11].

1612.

John Smith. *A Map of Virginia. With a Description of the Countrey, the Commodities, People, Government and Religion*. Oxford, 1612; rpt. Amsterdam: Theatrum Orbis Terrarum Ltd.; New York: Da Capo Press, 1973.

In some parts were found some Chesnuts whose wild fruit equalize the best in *France, Spaine, Germany, or Italy*, to their tastes that had tasted them all. Plumbs there are of 3 sorts. The red and white are like our hedge plumbs, but the other which they call *Putchamins*, grow as high as a *Palmeta*: the fruit is like a medlar; it is first greene then yellow, and red when it is ripe; if it be not ripe it will draw a mans mouth awrie, with much torment, but when it is ripe, it is as delicious as an Apricock.

They have Cherries and those are much like a Damsen, but for their tastes and colour we called them Cherries. we see some few Crabs, but very small and bitter. Of vines great abundance in many parts that climbe the toppes of the highest trees in some places, but these beare but fewe grapes. . . . Of those hedge grapes wee made neere 20 gallons of wine, which was neere as good as your French Brittish wine, but certainly they would prove good were they well manured. There is another sort of grape neere as great as a Cherry, this they call *Messaminnes*, they bee fatte, and the juyce thicke.

Neither doth the tast so well please whe[n] they are made in wine. They have a small fruit growing on lttle trese, husked like a Chesnut, but the fruit most like a very small acorne. This they call *Chechinquamins* which they esteeme a great daintie. They have a berry much like our gooseberry, in greatnesse, colour, and tast; those they call *Rawcomenes*, and doe eat them raw or boyled. Of these naturall fruits they live a great part of the yeare, which they use in this manner, *The walnuts, Chesnuts, Acornes, and Chechniquamens* are dryed to keepe. When they need them they breake them betweene two stones, yet some part of the walnut shels will cleave to the fruit. Then doe they dry them againe upon a mat over a hurdle. After they put it into a mortar of wood, and beat it very small: that done they mix it with water that the shels may sinke to the bottome. This water will be coloured as milke, which they cal *Pawcohiscora*, and keepe it for their use. *The fruit like medlers* they call *Putchamins*, they cast upon hurdles on a mat and preserve them as Pruines. *Of their Chesnuts and Chechinquamens* boyled 4 houres, they make both broath and bread for their chiefe men, or at their greatest feasts. . . .

In the watry valleyes groweth a *berry* which they call *Ocoughtanamnis* very much like unto Capers. These they dry in sommer. When they will eat them they boile them neare halfe a day; for otherwise they differ not much from poyson. *Mattoume* groweth as our bents do in meddows. The seede is not much unlike to rie, though much smaller. this they use for a dainty bread buttered with deare suet.

During Somer there are either *strawberries* which ripen in April; or mulberries which ripe[n] in May & June. Raspises hurtes; or a fruit that the Inhabita[n]ts call *Maracocks*, which is a pleasant wholsome fruit much like a lemond. Many *hearbes* in the spring time there are commonly dispersed throughout the woods, good for brothes and sallets, as Violets, Purslin, Sorrell, &c. . . .

The chiefe roote they have for foode is called *Tockwhoughe*, It groweth like a flagge in low muddy freshes. In one day a *Savage* will gather sufficient for a weeke. These rootes are much of the greatnes & taste of *Potatoes*. They use to cover a great many of the[m] with oke leaves & ferne, and then cover all with earth in the manner of a colepit; over it, on each side, they continue a great fire 24 hours before they dare eat it. Raw it is no better then poison, & being roasted, except it be tender and the heat abated, or sliced and dried in the sun, mixed with sorrell and meale or such like, it will prickle and torment the throat exteamely, and yet in sommer they use this ordinarily for bread. (pp. 11-13)

In the low Marishes *growe plots of Onyons* containing an acre of ground or more in many places; but they are small not past the bignesse of the Toppe of ones Thumbe. (p. 13)

The stalke [of corn] being green hath a sweet juice in it, somewhat like a suger Cane, which is the cause that when they gather their corne greene, they sucke the stakes: for as wee gather greene pease, so doe they their corne being greene, which excelleth their old. They plant also pease they cal *Affetamens*, which are the same they cal in *Italy, Fagioli*. Their Beanes are the same the Turkes cal *Garnases*, but these they much esteeme for dainties.

Their corne they rost in the eare greene, and bruising it in a mortar of wood with a Polt, lappe it in rowles in the leaves of their corne, and so boyle it for a daintie. They also reserve that corne late planted that will not ripe, by roasting it in hot ashes, the heat thereof drying it. In winter they esteeme it being boyled with beans for a rare dish, they call *Pausarowmena*. Their old wheat they first steep a night in hot water, in the morning pounding it in a mortar. They use a small basket for their Temmes, then pound againe the great, and so separating by dashing their hand in the basket, receive the flower in a platter made of wood scraped to that forme with burning and shels. Tempering this flower with water, they make it either in cakes covering them with ashes till they bee baked, and then washing them in faire water they drie presently with their owne heat: or else boyle them in water eating the broth with the bread which they call *Ponap*. The grouts and peeces of the cornes remaining, by fanning in a Platter or in the wind, away, the branne they boile 3 or 4 houres with water, which is an ordinary food they call *Ustatahamen*. But some more thrify then cleanly, doe burne the core of the eare to powder which they call *Pungnough*, mingling that in their meale, but it never tasted well in bread, nor broth. Their fish and flesh they boyle either very tenderly, or broyle it so long on hurdles over the fire, or else after the *Spanish* fashion, putting it on a spit, they turne first the one side, then the other, til it be as drie as their jerkin beefe in the west *Indies*, that they may keepe it a month or more without putrifying. The broth of fish or flesh they eate as commonly as the meat.

In May also among their corne they plant Pumpeons, and a fruit like unto a muske millen, but lesse and worse, which they call *Macocks*. These increase exceedingly, & ripen in the beginning of July, and continue until September. They plant also *Maracocks* a wild fruit like a

lemmon, which also inchease infinitely. They begin to ripe in September and continue till the end of October. (pp. 16-18)

1615.

Ralph Hamor. *A True Discourse of the Present State of Virginia*. London, 1615; rpt. Richmond: Virginia State Library, 1957.

. . . we reaped not so much corne from the labours of 30 men, as three men have done for themselves: to prevent which mischiefe heerafter Sir *Thomas Dale* hath taken a new course, . . he hath allotted to every man in the Colony, three English Acres of cleere Corne ground, which every man is to mature [probably *manure*] and tend, being in the nature of Farmers, . . . and they are not called unto any service or labor belonging to the Colony, more than one moneth in the yeere, which shall neither be in seede time, or in Harvest, for which, doing no other duty to the Colony, they are yeerly to pay into the store two barrells and a halfe of Corne: there to be reserved to keep new men, which shall be sent over, the first yeere after their arrival. . . . (p. 17)

The affaires in the Colony, being so well ordered, and the hardest taskes already overpast, that whosoever (now, or heerafter) shall happily arrive there, shall finde a hansom howse of some foure roomes or more, if he have a family, to repose himself in rent freee, and twelve English Acres of ground, adjoyning thereunto, very strongly impailed, which ground in onely allotted unto him for *Roots, Gardaine hearbs, and Corne*: neither shall hee need to provide himselfe, as were wont the first planters, of a yeers provision of victualls, for that the store there will bee able to afford him, & upon these conditions he shall be entertained; He shall have for himselfe & family, a competent 12 months provision delivered unto him, in which time it must bee his care to provide for himselfe and family ever after, . . . for his better subsistance he shall have Poultry, and swine, and if he deserve it, a Goate or two, perhaps a Cow given him, which once compast, how happily he may live, as doe many there, who I am sure will never returne I submit to their own future well experienced judgements. (pp. 19-20)

. . . the Land is stored with plenty and variety of wilde beasts, Lions, Bears, Deere of all sorts, . . . *Beavers, Otters, Foxes, Racounes*, almost as big as a *Fox*, as good meat as a lamb, *hares, wild Cats, muske rats, Squirills* flying, and other of three or foure sorts, *Apossumes*, of

the bignesse and likenesse of a Pigge of a moneth
ould. . . .

Of each of these beasts, the Lion excepted, my selfe
have many times eaten, and can testifie that they are not
onely tastefull, but also wholesome and nourishing foode.
(pp. 20-21)

Nor are these provision of bread, flesh and fish, al we
have for sustentation of mans life, hehold more change and
variety of foode, which our soile and climate affordeth,
Carrats, Parsneps, Turneps, Raddish, Pumpions (of the
west Indie kinde in great abundance, of one seede I have
seen an hundreth, much better then ours and lasting all
the yeere) *Cabbage, Parsley*, all manner of pothearbs
and other hearbes, *Margerum, Time, winter-Savory,*
Lettice Purslaine, &c., and besides the naturall graine of
that Country, as wheate pease and beanes, it did me much
good to view our English wheate how forward it was, full
eard, of one graine fortie eares or more, a span long, and
only wanting ripening in *mid June*, our English pease then
ripe, and beanes very forward, and English barly very
hopefull, such as mine eies never beheld better in
England. . . .

To goe yet a little further, I my selfe know no one
Country yeelding without art or industry so manie fruites,
sure I am England doth: wilde grapes in abundance al the
woods over, their juice sweete and pleasant in taste, some
of them wee have replanted in a vineyard adjoining to
Henrico, the quantity of three or foure Akers which were
this yeere very plentifully laden, to what perfection they
will come, the next returne will advertise: *Cherries* little
inferior to ours, which if replanted may proove as much
better as now they are worse *Pissmienplums* in bygnes and
fashion like a *Medlar* of a slipticke quality, other sorts of
plummes like to our wheat plumms, and in goodnes
answerable: great fields and woods abounding with
Strawberies much fairer and more sweete then ours,
Mulberries of great bignesse, and about the *Bermuda*
Cittie and *Hundirds* thereunto belonging great store
thereof, *Maricocks* of the fashion of a Lemmon whose
blossome may admit comparison with our most delightsome
and bewtifull flowers, and the fruite exceeding pleasant
and tastfull: *Chesnut-trees* towards the fals as many as
oakes, and as fertile, many goodly groves of *Chincomen*
trees with a husk like unto a Chesnut, raw or boyled,
luscious and harty meate: Walnuts of three or foure
sorts, whereof there might be yeerely made great quantity
of oyles, as usefull and good as that of Olives: some
filberds I have seene, Crabbes great store, lesse, but not

so sower as ours, which grated with the *Siens* of English apple trees, without question would beare very good fruite, and we doubt not but to have the *Siens* enough the next yeere, there being in Sir Thomas *Gates* his garden at Jamestown, many forward apple & peare trees come up, of the kernels set the yeere before.

If all this be not sufficient, loe further incouragement, the collony is already furnished with two hundred neate cattell, as many goates, infinite hogges in heards all over the woods, besides those to everie towne belonging in generall, and every private man, some Mares, Horses & Colts, Poultry great store, besides tame Turkeis, Peacockes and Pigeons plentifully increasing and thriving there, in no Countrie better. (pp. 21-23)

[1616].

John Rolfe. *A True Relation of the State of Virginia Lefte by Sir Thomas Dale Knight in May Last 1616*. Charlottesville: Univ. Press of Virginia, 1971.

. . . there are already, as *Neate cattle*, horses, Mares, and *Coates*, which are carefully preserved for increase both males and females, the one for the plough, thother for mylke butter and cheese. . . . (p. 3)

But for the peoples present labors, they have *Indian Wheate* called *Mays* in the *West Indies*, *Pease* and *Beanes*: English *Wheate*, *Pease*, *Barley*, *Turnips*, *Cabbages*, *Pumpions* *West-Indian* and others, *Caretts*, *Parsnips* and such lyke, besides hearbes and flowers all of our English seedes, both for pleasure and for the kitchin so good, so fruitfull, so pleasant and profitable, as the best made ground in England can yeild. . . . About two yeres since *Sir Thomas Dale* (whose worth and *Name* in concluding this *Peace*, and manning of the affayres of the *Colony*, will outlast the standing of the *Plantation*) found out two seasons of the yere to catch fishe, namely the *Spring*, and the *Fall*. He himself tooke no smale paines in the triall, and at one hale with a Sayne coought five thousand fishe, three hundred of them as bigg as *Codd*, the least of the residue a kind of Salmon Trout two foote long: yet durst he not adventure on the mayne [*deleted word*] for breaking his nett. Lykewise twoe men with axes, and lyke weapons have taken and kild neere the shoare and brought home forty as greate as *Codd* in two or three howers space. So that now there is not so great plenty of victualles in anie of the forenamed kind yerely with smale paynes to be gotten in any part of England amongst so few people. And whereas heretofore we were costrayned

yerely to seeke after the Indians, and intreate them to sell us Corne, which made them esteeme very basely of us: now the case is altered, they sue to us, come to our Townes, sell the skins from their shouldiers which are their best garmentes to buy corne: yea som of their petty Kinges have borrowed this last yere, 4. or 500, bushelles of wheate, for payment whereof this harvest, they have mortgaged their wholl Countries, som of them not much less in quantytie then a Sheir in England. (pp. 5-6)

These *Officers* [of the company at Jamestown] are tied to mayntayne themselves and famylies with food and rayment by their owne and their servauntes industry.

The Laborers are of twoe sortes. Some ymployed onlie in the generall workes, who are fedd and clothed out of the stoore: others especyally Artyficers, as Smithes, Carpenters, Shoemakers, Tailors, Tanners &c doe worke in their professions for the *Colony*, and mayntayne themselves with food and apparrell, having tyme lymytted them to till and manure their ground. (p. 7)

[The farmers are bound] To mayntayne themselves and famylies with food and rayment. And every *Farmor* to paie yerely into the Magazin for himself and every manservant two barrells and a half apeece of their best Indian wheate, which amounteth to twelve bushelles and a half of Englishe measure. (p. 8)

At *Dales Gifte* (lieng upon the sea neere unto *Cape Charles*, about 30. myles from *Kequoughtan*) are 17. under the commaund of one Leiftenaunte *Cradock*: all these are fedd and mayntayned by the *Colony*. Their labor is to make salte; and to catch fishe at the 2. seasons aforemencioned. (pp. 10-11)

The number of Neate Cattle Horses and Goates which were alive in Virginia at Sir Thomas Dale his departure thence.

[The list of livestock includes 83 cows, heifers, and cow calves; 41 steers; 20 bulls; 3 horses; 3 mares; 216 male and female goats and kids; "Hoggs wilde and tame not to be nombered;" and "Powltry great plenty."] (pp. 14-15)

1619.

"Letter of John Pory, 1619." In *Narratives of Early Virginia 1606-1625*. Ed. Lyon Gardiner Tyler. New York: Charles Scribner's Sons, 1907.

We have had this yeare a plentifull cropp of English wheat, though the last harvest 1618 was onely shed upon

the stubble, and so selfe-sowne, with out any other manurance. In July last so soon as we had reaped this selfe-sowen wheate, we sett Indian corne upon the same grounde, which is come up in great abundance; and so by this meanes we are to enjoye two crops in one yeare from off one and the same field. . . .

Vines here are in suche abundance, as where soever a man treads, they are ready to embrace his foote. I have tasted here of a great black grape as big as a Damascin [Damson], that hath a true Muscatell-taste [the muscadine, the fruit of which grows in clusters of three or four berries]; the vine whereof now spending itselfe to the topps of high trees, if it were reduced into a vineyard, and there domesticated, would yield incomparable fruite. The like or a better taste have I founde in a lesser sorte of black grapes [the frost grape]. White grapes [probably the scopenong, found near the North Carolina border] also of great excellency I have hearde to be in the country; but they are very rare, nor did I ever see or taste of them. For cattle, they do mightily increase here, both kine, hogges and goates, and are much greater in stature, then the race of them first brought out of England. (p. 284)

1621.

Virginia Company. "Instructions to the Governor and Council of State in Virginia." In *The Three Charters of the Virginia Company of London With Seven Related Documents; 1606-1621*. Williamsburg: Virginia 350th Anniversary Celebration Corporation, 1957, pp. 109-125.

Item: that according to His Majesties gracious advise and the desire & expectation of the whole state here, you draw the people from the excessive planting of tobacco and that, according to a late order of court in that behalfe made the thirteenth of June last, you suffer them not to plant in one yeare alone one hundred waight tobacco the head, that is the person; and that you do provide by some generall course to bee held amongst them that they apply themselves to the soweing and planting of corne in good plentie that ther may bee alwaies a large proportion not onlie for their owne use, but store also for such as in great multitudes wee hope yearly to send; likewise by the same generall course to cause the generall inhabitants and households to enclose by pale & strong fences some fitting portion of our land for the keping of cowes, tame swine and poultrie; and for the making all due provitiones for the encrease & preservation of the bread of all sorts of cattle, and in particular kine, wherof wee thinke itt most

unfitt that any should bee as yett killed and requier your vigilant care for the inhibiting thereof. (p. 115)

Item: wee doe also especially recommend unto you the planting of vines in abundance and that the vigneron sent with so great charge to the Company bee fairely & carefullie provided for. (p. 116)

Item: that your corne mills bee presentlie erected and puplique bakehouses in everie burrough bee built with all speed and dilligence. (p. 117)

Item: salt, pich and tarr, soape ashes, &c., often recommended and sett up, and for which fittige men & matterialles have been sent to the great charge of the Company and yett daylie complaints come to us of the want of them, wee desier you will now prosecute and further with all dilligence & care.

Item: your makeing of oile of wallnuts, your employing your apothecaries in distilling of hott waters out of your lees of beere and searching after minierall dyes, gummes, druggs, and the like things, wee desier you not to forgett and good quanteties of all sorts to send us by all shipp. (p. 118)

1622.

Edward Waterhouse. *A Declaration of the State of the Colony in Virginia*. London, 1622; rpt. Amsterdam: Theatrum Orbis Terrarum Ltd.; New York: Da Capo Press, 1970.

. . . in December last they had planted and cultivated in VIRGINIA Vines of all sorts, (as well those naturally growing, as those other Plants sent them from these parts of Europe) Orenges and Lemon-trees, Figge-trees, Sugar-Canes, Cotton-wooll, Cassavi Rootes, (that make very good bread) Plantanes, Potatoes, and sundry other *Indian* fruits and plants not formerly seene in VIRGINIA, which at the time of their said Letters beganne to prosper very well. . . . (p. 8)

The Letters of the *French Vignerons* or *Vine-men*, procured out of *France* & sent over into VIRGINIA, did likewise assertaine, that no Countrey in the world was more proper for Vines, Silke, Rice, Olives, and other Fruits, then VIRGINIA is: and that it faire excelled their owne Countrey of *Languedocke*; the Vines of divers sorts being in abundance naturally over all the Countrey: and they having planted some cuttings of Vines at *Michaelmas* last, in their Letters affirme that these bare Grapes

already this Spring, to their great wonder, as being a thing they suppose not heard of in any other Country. A taste of Wine made of the wilde grape, they last yeare sent, with hope to send a good quantitie this next Vintage. . . . (p. 10)

1649.

Richard Wodenoth. "A Perfect Description of Virginia: Being, A full and true Relation of the present State of the Plantation, their Health, Peace, and Plenty . . ." In *Tracts and Other Papers, relating principally to the Origin, Settlement, and Progress of the Colonies in North America, from the discovery of the country to the year 1776*. Ed. Peter Force. Vol. II, No. 8. 1836; rpt. New York: Peter Smith, 1947.

1 That there are in *Virginia* about fiteene thousand *English*, and of *Negroes* brought thither, three hundred good servants.

2 That of *Kine, Oxen, Bulls, Calves*, twenty thousand, large and good, and they make plenty of Butter and very good Cheese.

3 That there of an excellent raise, about two hundred *Horse* and *Mares*. . . .

5 That for *Sheepe* they have about three thousand, good wooll.

6 That for *Coates* there number is five thousand, thrive well.

7 That for *Swine* both tame and wilde (in the Woods) innumerable; the flesh pure and good, and Bacon none better.

8 That for Poultry, *Hens, Turkies, Ducks, Geese*, without number.

9 That they yearly plow and sow many hundred Acres of *Wheat*, as good, and faire, as any in the world, and great increase.

10 That they have plenty of *Barley*, make excellent Mault.

11 That they have *Six publike Brewhouses*, and most brew their owne Beere, strong and good.

12 That their *Hopps* are faire and large, thrive well.

13 That they sell their *Beefe* at two pence halfe penny a pound, *Pork* at three pence a pound, plentifully. (pp. 3-4)

20 That they have Roots of severall kindes, *Potatoes, Sparagus, Carrets, Turnips, Parsnips, Onions, and Hartichokes*. (p. 4)

23 That their *Maize* or *Virginia* Corne, it yeelds them five hundred for one, increase, ('its set as we doe garden Pease) it makes good Bread and Furmitie, will keep seven years, and maults well for Beere. . . .

24 That they have store of *Indian Pease*, better then ours, *Beans*, *Lupines*, and the like.

25 They have store of *Bees* in their Woods, make plenty of honey and wax, and also tame *Bees* in hives about their Houses. (p. 4)

They have 4 Wind-mills, and 5 Water-mills to grind their Corn; besides many Horse-mills of several kinds, and Hand-mills for several uses. . . . (p. 5)

Mr. *Richard Bennet* had this yeer out of his Orchard as many Apples as he made 20 Butts of excellent Cider.

And Mr. *Richard Kinsman* hath had for this three or four yeers, forty or fifty Butts of Perry made out of his Orchard, pure and good.

So that you may perceive how proper our Country is for these fruits, and men begin now to plant great Orchards, and find the way of Grafting upon Crab-stocks, best for lasting, here being naturally in the Land store of wild Crab-trees.

Mr. *Hough* at *Nausamund*, hath a curious Orchard also, with all kind and variety of several fruits; the Governour in his new Orchard hath 15 hundred fruit-trees, besides his Apricocks, Peaches, Mellicotons, Quinces, Wardens, and such like fruits. (p. 14)

. . . *Raconnes*, as good meat as Lambe. (p. 16)

. . . *Sheepshead*, this Fish makes broath so like Mutton-broath, that the difference is hardly known. (p. 17)

[Listed as varieties of fish available:] Codde, Basse, Drummes, Conger, Eeles, Trouts, Mulletts, Plaice, Grampus, Porpus, Scales, Sturgeons, Stingraes, Brets, White Salmon, Soles, Herring, Conny-fish, Rocke-fish, Lampres, Cray-fish, Shads, Perch, Crabbs, Shrimps, Crecy-Fish, Oysters, Cockles, Mussels, St. George Fish, Toad-Fish. (p. 17)

Fruits they have, *Strawberies*, *Gooseberies*, *Raspices*, *Maracokos*, *Puchamines*, *Muskmillions*, *Pumpions*; And for *Fruits* brought thither and planted. *Aples*, *Peares*, *Quinces*, *Apricocks*, *Peaches*; and many more kines excellent good, &c. (p. 18)

1650.

E. W. "Virginia: More especially the South part thereof, Richly and truly valued: *viz.* The fertile *Carolana*, and no lesse excellent Isle of *Roanok*, of Latitude from 31. to 37. Degr. relating the meanes of raying infinite profits to the Adventurers and Planters." In *Tracts and Other Papers, relating principally to the Origin, Settlement, and Progress of the Colonies in North America, from the discovery of the country to the year 1776.* Ed. Peter Force. Vol. III, No. 11. 1844; rpt. New York: Peter Smith, 1947.

[Listed among supplies needed for planters:]

For Houshold stufte: Provide one great Iron Pot, large and small Kettles, Skellets, Frying pannes, Gridiron, Spit, Platters, Dishes, Spoons, Knives, Sugar, Spice, Fruit, and Strong water at Sea for sicke men. (p. 10)

[In Virginia] in its season your foot can hardly direct it selfe where it will not be died in the bloud of large and delicious Strawberries: The Rivers which every way glide in deepe and Navigable Channels, betwixt the brests of this uberous Countrey, and contribute to its conveniency beauty and fertility, labour with the multitude of their fishy inhabitants in greater variety of species, and of a more incomparable delicacy in tast and sweetnesse then whatever the European Sea can boast of: Sturgeon of ten feet, Drummes of sixe in length; Conger, Eeles, Trout, Salmon, Bret, Mullet, Cod, Herings, Perch, Lampreyes, and what ever else can be desired to the satisfaction of the most voluptuous wishes. (p. 11)

Deere in a numerous abundance, and delicate Venison, Racoones, Hares, Conyes, Bevers, Squirrell, Beares, all of a delightfull nourishment for food. . . . The ayre it selfe is often clouded with flights of Pigeons, Partriges, Blackbirds, Thrushes, Dottrels, Cranes, Hernes, Swans, Geese, Brants, Duckes, Widgeons, Oxeyes, infinites of wilde Turkeyes, which have been knowne to weigh fifty pound weight, ordinarily forty.

And the native Corne of the Country Maiz, is so gratefull to the Planter, that it returneth him his entrusted seed with the increase of 2 or 3 hundred interest. . . . Planted in March, April, or May, it is ready for the Barne in June, July, and August; and of this by a provident management, you may have yeerely three or foure Harvests. The stalk bruised yields a juice as big as Rice, pleasant as Sugar, and the green Ears boyled in such juice is comparable in agreeablenesse to the

palats to what ever our Pease, Sparagus, or Hartichoke, hat eyther for satisfaction or delicacy. Nor is the Corne difficult in preservation, for in six or seven yeares there is scarce any sensibility of its corruption. (p. 12)

The West-Indie Potatoe (by much more delicate and large then what wee have heere growing) besides that it is a food excellently delicious and strongly nourishing, fixes himself wherever planted, with such an irradicable fertility, that being set it eternally grows: of this an extraordinary pleasing and strong drinke may be composed.

Nor is the Maiz lesse commendable for bread then malting, of both which in its use it affordeth a peculiar goodnesse and convenience. . . . (p. 48)

[Items listed among a] valuation of the Commodities growing and to be had in Virginia [in 1621:]

Annice seeds, 40s. the hundred.

Powder Sugar, Panels, Muscavadoes and whites, 25s. 40. and 3l. the hundred.

Sturgeon, and Caveare, as it is in goodnesse.

Salt, 30s. the weight.

Oyle of Walnuts, 12l. the tun.

Saffron, 20s. the pound.

Honey, 2s. the gallon. (pp. 51-52)

[c. 1650].

Colonel Norwood. "A Voyage to Virginia." In *Tracts and Other Papers, relating principally to the Origin, Settlement, and Progress of the Colonies in North America, from the discovery of the country to the year 1776*. Ed. Peter Force. Vol. III, No. 10. 1844; rpt. New York: Peter Smith, 1947.

Many sorrowful days and nights we spun out in this manner [on board ship], till the blessed feast of *Christmas* came upon us, which we began with a very melancholy solemnity; and yet, to make some distinction of times, the scrapings of the meal-tubs were all amassed together to compose a pudding. *Malaga* sack, sea water, with fruit and spice, all well fryed in oyl, were the ingredients of this regale, which raised some envy in the spectators; but allowing some privilege to the captain's mess, we met no obstruction, but did peaceably enjoy our *Christmas* pudding. (p. 17)

The captain had a gun charged [after the shipwreck on an island], and the moon shining bright in his favour, he killed one duck of the flock that flew over us, which was roasted on a stick out of hand by the seamen. . . .

In passing a small gullet we trod on an oyster bank that did happily furnish us with a good addition to our duck. When the cooks had done their parts, we were not long about ours, but fell on without using the ceremony of calling the rest of our company. . . . The bones, head, legs, and inwards were agreed to be the cook's fees; so we gave God thanks, and return'd to our friends, without making boast of our good fortunes. (pp. 20-21)

Whilst this very cold season continued, great flights of fowl frequented the island, geese, ducks, curleues, and some of every sort we killed and roasted on sticks, eating all but the feathers. It was the only perquisite belonging to my place of preference to the rest, that the right of carving was annexed to it, wherein, if I was partial to my own interest, it was in cutting the wing as large and full of meat as possible; whereas the rest was measured out as it were with scale and compass.

But as the wind veered to the south-ward, we had greater warmth and fewer fowl, for they would then be gone to colder climates. In their absence we were confined to the oyster bank, and a sort of weed some four inches long, as thick as houseleek, and the only green (except pines) that the island afforded. It was very insipid on the palate; but being boiled with a little pepper (of which one had brought a pound on shore) and helped with five or six oysters, it became a regale for every one in turn. (pp. 23-24)

Of the three weak women before-mentioned, one had the envied happiness to die about this time; and it was my advice to the survivors, who were following her apace, to endeavour their own preservation by converting her dead carcase into food, as they did to good effect. The same counsel was embrac'd by those of our sex: the living fed upon the dead. . . . (p. 24-25)

. . . our only friend the oyster bank was all we had to rely on; which being well stew'd in their own liquor, and put up into bottles, I made no doubt, by God's blessing, but that two of them well filled, would suffice to prolong my life in moderate strength. . . . (p. 26)

One of [the Indians] made me a present of the leg of a swan, which I eat as privately as it was given me, and thought it so much the more excellent, by how much it was larger than the greatest limb of any fowl I ever saw. (p. 29)

The tide was going out, and the water very shoal, which gave occasion to any one that had a knife, to treat himself with oysters all the way. (p. 32)

We had a boiled swan for supper. . . . (p. 33)

A mat was spread without the [Indian queen's] house, upon the ground, furnish'd with *Pone*, *Homini*, oysters, and other things. (p. 34)

[The Indian king] sent his daughter . . . with a great wooden bowl full of homini (which is the corn of that country, beat and boiled to mash). . . . Instead of a spoon there was a well-shap'd muscle-shell that accompanied the bowl. (p. 35)

Towards morning we were treated with a new regale brought to us by the same fair hand again. It was a sort of spoon-meat, in colour and taste not unlike to almond-milk temper'd and mix'd with boiled rice. The ground still was *Indian* corn boiled to a pap, which they call *Homini*, but the ingredient which performed the milky part, was nothing but dry pokickery nuts, beaten shells and all to powder, and they are like our walnuts, but thicker shell'd, and the kernel sweeter; but being beaten in a mortar, and put into a tray, hollow'd in the middle to make place for fair water, no sooner is the water poured into the powder, but it rises again white and creamish; and after a little ferment it does partake so much of the delicate taste of the kernel of that nut, that it becomes a rarity to a miracle. (p. 37)

About midnight following, the king sent to invite me to his fire. He placed me near him as before, and in the first place shewing me quarters of a lean doe, new brought in. He gave me a knife to cut what part of it I pleased, and then pointing to the fire, I inferr'd, I was left to my own discretion for the dressing of it. I could not readily tell how to shew my skill in the cookery of it, with no better ingredients then appear'd in sight; and so did no more but cut a collop and cast it on the coals. His majesty laugh'd at my ignorance, and to instruct me better, he broach'd the collop on a long scower, thrust the sharp end into the ground . . . and turning sometimes one side, sometimes the other, to the fire, it became fit in short time to be served up, had there been a dining-room of state such as the excellent king deserved. . . . The rest of the doe was cut in pieces, stewed in a pipkin, and then put into my hands to dispose of amongst my company. (p. 38)

. . . a wild turkey boiled, wth oysters, was preparing for my supper, which, when it was ready, was served up in the same pot that boiled it. It was a very savoury mess, stew'd with muscles, and I believe would have passed for a delicacy at any great table in *England*. . . . (p. 42)

Our landlord *Jenkin Price* [at Accomac] . . . took great care to provide meat for us; and there being a dairy and hens, we could not want. (p. 48)

1656.

John Hammond. "Leah and Rachel, or, the Two Fruitfull Sisters Virginia, and Mary-land: Their Present Condition, Impartially stated and related." In *Tracts and Other Papers, relating principally to the Origin, Settlement, and Progress of the Colonies in North America, from the discovery of the country to the year 1776*. Ed. Peter Force. Vol. III, No. 14. 1844; rpt. New York: Peter Smith, 1947.

The Women are not (as is reported) put into the ground to worke, but occupie such domestique imployments and houswifery as in *England*, that is dressing victuals, righting up the house, milking, imployed about dayries, washing, sowing, &c. and both men and women have times of recreations, as much or more than in any part of the world besides, yet som wenches that are nasty, beastly and not fit to be so imployed are put into the ground, for reason tells us, they must not at charge be transported and then mantained for nothing, but those that prove so aukward are rather burthensome then servants desirable or usefull.

The Country is fruitfull, apt for all and more then *England* can or does produce, the usuall diet is such as in *England*, for the rivers afford innumerable sortes of choyce fish, (if they will take the paines to make wyers or hier the Natives, who for a small matter will undertake it,) winter and summer, and that in many places sufficient to serve the use of man, and to fatten hoggs, water-fowle of all sortes are . . . plentifull and easie to be killed, yet by many degrees more plentifull in some places then in othersome, Deare all over the Country, and in many places so many, that venison is accounted a tiresom meat, wilde Turkeys are frequent, and so large that I have seen some weigh neer threescore pounds. . . .

The Country is exceedingly replenished with Neat cattle, Hoggs, Goats and Tame-fowle, but not many sheep; so that mutton is somewhat scarce, but that defect is supplied with store of Venison, other flesh and fowle; The

Country is full of gallant Orchards, and the fruit generally more luscious and delightfull then here, witnesse the Peach and Quince, the latter may be eaten raw savourily, the former differs and as much exceeds ours as the best relished apple we have doth the crabb, and of both most excellent and comfortable drinks are made, Grapes in infinite manners grow wilde, so do Walnuts, Smalnuts, Chesnuts and abundance of excellent fruits, Plums and Berries, not growing or known in *England*; graine we have, both *English* and *Indian* for bread and Bear, and Pease besides *English* of ten several sorts, all exceeding ours in *England*, the gallant root of Potatoes are common, and so are all sorts of rootes, herbes and Garden stufte.

It must needs follow then that diet cannot be scarce, since both rivers and woods affords it, and that such plenty of Cattle and Hogs are every where, which yeeld beef, veal, milk, butter, cheese and other made dishes, porke, bacon, and pigs, and that as sweet and savoury meat as the world affords, these with the help of Orchards and Gardens, Oysters, Fish, Fowle and Venison, certainly cannot but be sufficient for a good diet and wholesome accommodation, considering how plentifully they are, and how easie with industry to be had.

Beare is indeed in some place constantly drunken, in other some, nothing but Water or Milk, and Water or Beverige; & that is where the goodwives . . . are negligent and idle; for it is not for want of Corn to make Malt with (for the Country affords enough) but because they are sloathfull and careless. . . . (pp. 12-14)

1669.

Nathaniel Shrigley. "A True Relation of Virginia and Mary-Land; With the Commodities therein, which in part the Author saw; the rest he had from knowing and Credible persons in the Moneths of February, March, April and May." In *Tracts and Other Papers, relating principally to the Origin, Settlement, and Progress of the Colonies in North America, from the discovery of the country to the year 1776*. Ed. Peter Force. Vol. III, No. 7. 1844; rpt. New York: Peter Smith, 1947.

The Country is naturally full of Vines, Fruit Trees, and Timber, As,

. . . multitudes of Rasberies, Strawberies, Barberies, Cranberies, with infinite of all sorts of Hearbs; the best Garden in *England* affords not better.

In Orchards all sorts of Apple-Trees, Pear-Trees, Quince, Peach, Apricocks, Cherries, Figg-Trees, and

Vines; Gardens as good as *England* affords for flowers, hearbs and roots of all sorts; with Colworts, Musmillions, Cuccumbers, Watermillions, May-cocks, Hornes, Peshaues, Rose-Trees, sweet-Bryers, and many things more.

There is a Root common in the Woods called *Tuckaho*, the Natives eat it for bread; our swine eat it; with Acorns and Nuts of all sorts, they are Fat; and is the sweetest Bacon that ever man tasted. . . .

There is plenty of English graine, as Wheat, Barley, Beanes, Peas and Oats.

The ground is very fruitful, and produceth plentiful Crops with great speed, what ever is planted or Sown; as for example, one careful laborious man will plant, tend, and get in 50. barrels of Indian Wheat, without the help of Man, Horse or Oxe; each barrel is five English bushels. And if the stone or seed of any fruit be sown, it will bear the third year without grafting. . . . (p. 4-5)

1676.

Thomas Glover. *An Account of Virginia, its Scituation, Temperature, Productions, Inhabitants and their manner of planting and ordering Tobacco &c.* 1676; rpt. Oxford: B. H. Blackwell, 1904.

In the Rivers are great plenty and variey of delicate Fish; one kind whereof is by the English called a *Sheepshead*, from the resemblance the eye of it bears with the eye of a Sheep: This fish is generally about fifteen or sixteen inches long, and about a foot broad; it is a wholesom and pleasant fish, and of easie digestion. A Planter does oftentimes take a dozen or fourteen in an hours time, with hook and line.

There is another sort which the English call a *Drum*; many of which are two foot and a half or three foot long. This likewise a very good fish, and there is great plenty of them. In the head of this fish there is a jelly, which being taken out and dried in the Sun, then beaten to powder and given in broth, procureth speedy delivery to women in labour.

At the heads of the Rivers there are *Sturgeon*, and in the Creeks are great store of small fish, as *Perches*, *Crokers*, *Taylor*s, *Eels*, and divers others whose names I know not. Here are such plenty of *Oysters* as they may load ships with them. At the mouth of *Elizabeth River*, when it is a low water, they appear in rocks a foot above water. There are also in some places great store of *Muscles* and *Cockles*; there is also a fish called a *Sting-ray*, which much resembleth a *Skate*, only on one side of his tayl grows out a sharp bone like a bodkin about four or five inches long. . . . (pp. 5-6)

As to the *Fruit-Trees* of the Countrey, it affords great plenty: For there are few Planters but that have fair and large Orchards, some whereof have twelve hundred Trees and upward, bearing all sorts of *English Apples*, as *Pear-mains*, *Pippins*, *Russetens*, *Costards*, *Marigolds*, *Kings-apples*, *Magitens*, *Batchelours*, and many others, of which they make great store of Cider.

Here are likewise great *Peach-Orchards*, which bear such an infinite quantity of Peaches, that at some Plantations they beat down to the Hoggs forty bushels in a year.

Here are also great store of *Quinces*, which are larger and fairer than those of *England*, and not so harsh in taste; of the juice of these they also make Quince-drink.

Here are likewise *Apricocks*, and some sorts of *English Plums*, but these do not ripen so kindly as they do in *England*.

There are some sorts of *Pears*, but at very few Plantations; I have seen the *Bergamy*, *Warden*, and two or three other sorts, and these are as fair, large and pleasant as they are in *England*.

Here grow as good *Figgs*, as there do in *Spain*, but there are few planted as yet.

Those that take the pains to plant *Goose-berries*, have them; but I never saw any of our *English Currants*, (*Riberries*) there, and it is observ'd, that *Oranges* and *Limons* will not grow there, though they do in more Northern Countries. (pp. 13-14)

The meanest Planter hath store of *Cherries*, and they are all over *Virginia* as plentiful as they are in *Kent*. The *Cherry-Trees* grow more large generally than they do in *England*, and bear more plentifully (*sic*) without any pains-taking of digging about them, or pruning them.

There groweth wild in some places of the Woods a Plum somewhat like our *Wheat-Plum*, but it doth exceed it, being much more succulent.

In the Woods there are abundance of *Vines*, which twine about the Oaks and Poplars, and run up to the top of them; these bear a kind of *Claret-grapes* [asterisked to refer to marginal heading "These Vines have very large Bodies"] of which some few of the Planters do make Wine, whereof I have tasted; it is somewhat smaller than *French Claret*; but I suppose, if some of these Wines were planted in convenient vine-yards, where the Sun might have a more kindly influence on them, and kept with diligence and seasonable pruning, they might afford as good grapes as the *Claret-Grapes* of France are.

There is also in the Woods a little Shrub which beareth a Berry like our *Elder-berry*, and is a very pleasant Berry to eat.

I lately made mention of the *Chesnut*, *Walnut* and *Hazel-Tree*, which all of them bear their several Nuts; and beside these, here is another called a *Chincopine*, which is like a Chesnut, with a Burry husk, but lesse by far.

Their Gardens have all sorts of *English* Pot-herbs and sallets; they have *Cabbages*, *Colworts*, *Colly flowers*, *Parsnips*, *Turnips*, *Carrets*, *Potatoes*, and *Yams*; and such Herbs as grow wild in *England*, and do not grow there, they plant, as *Wormwood*, *Fetherfew*, *Houseleek*, *Carduus Benedictus*, *Rue*, *Coriander*, *Enula*, and the like. . . .

There grow wild in the Woods, *Plantane* of all sorts, *Yellow-Dock*, *Bur-Dock*, *Solomons-seal*, *Egrimony*, *Centory*, *Scabious*, *Groundsel*, *Dwarf-Elder*, *Yarrow*, *Purslan*, and white *Maiden-hair* the best that ever I saw. Upon the sides of the Hills, *Asatum*; and on the Bay-side, *Soldanella* or *Sea-Scurvygrass* in great plenty.

Here groweth the *Radix Serpentaria Nigra*, which was so much used in the last great pestilence . . . Here is also an herb which some call *Dittany*, others *Pepper-wort*; it is not *Dittany of Candia*, nor *English Dittander*; it groweth a foot or a foot and half high, the leaves are about the bredth of a goate, and figur'd like a heart, and short out of the stalk and brances one of a side directly opposite to each other; it smelleth hot like Pepper, and biteth upon the Tongue. The water of this herb distill'd out of a Limbeck, is one of the best things I know to drive worms out of the Body; and an ounce of this water taken, provoketh sweat plentifully.

Here grow two Roots, which some Physicians judg, the one to be *Turbith*, the other *Mechoacan* . . . Both these Roots are purging. . . .

Here groweth a Plant about a foot and half or two foot in height, the leaves are rugg'd like to a Borage leaf, but they are longer, and not above two fingers broad; about the stalk, where the leaves grow out, there hang Berries, which being ripe are yellow: The *English* call it the *Fever* and *Ague-root*. This Root being newly taken out of the ground, and a dram and half of it infused in beer or water the space of twelve hours, purgeth downward with some violence, but I have given a dram of the Root in powder, and then it only moveth sweat, and that but moderatly. It is a little bitter in taste, and therefore somewhat hot. (pp. 15-18)

. . . their flocks of *Cattel* . . . are greater than ours, considering the quantity of People, and might be much

larger than they are, were the Inhabitants as careful in looking after them and providing fodder for them as they in *England* are. All that they give their Cattel in winter is only the husks of their *Indian Corn*, unless it be some of them that have a little wheat-straw; neither do they give them any more of these than will serve to keep them alive, by reason whereof they venture into the Marshy grounds and swamps for food, where very many are lost. (pp. 18-19)

The Planters houses are built all along the sides of the Rivers for the conveniency of Shipping; they build after the *English* manner, whiting the inside of their houses with Mortar, made of burnt Oyster-shells instead of lime. They have pure and wholesom water, which they fetch wholly from Springs, whereof the Country is so full, that there is not a house but hath one nigh the door. (pp. 30-31)

1676-1701.

[William Fitzhugh]. *William Fitzhugh and His Chesapeake World 1676-1701: The Fitzhugh Letters and Other Documents*. Ed. Richard Beale Davis. Virginia Historical Society Documents, Vol. 3. Chapel Hill: Univ. of North Carolina Press, 1963.

I desire you to speak to Capt. Norrington or any of your friends being Master of a Ship, bound for Potomack River to bring me two or three couple of Rabbits. (Letter to John Cooper, London merchant, 5 June 1682; pp. 126-27)

I have a great mind to try if Olives would not thrive in this Country, since I am well assured they grow & thrive well in the Streights, as far in the Northern Latitude as we are here, some of which sort you might procure in London: Therefore I would desire you to procure for me some of them, together with directions how to manage them. (Letter to Samuel Hayward, Virginia neighbor, 3 June 1684; p. 163)

As first the Plantation where I now live contains a thousand Acres, . . . upon it there is three Quarters well furnished, with all necessary houses, ground & fencing, together with a choice crew of Negros at each plantation, most of them this Country born, the remainder as likely as most in Virginia, there being twenty nine in all, with Stocks of cattle & hogs at each Quarter, upon the same land is my own Dwelling house, furnished with upon the same land is my Dwelling house, furnished with all accomodations for a comfortable & gentile living, as a very

good dwelling house, with 13 rooms in it, four of the best of them hung, nine of them plentifully furnished with all things necessary & convenient, & all houses for use well furnished with brick Chimneys, four good Cellars, a Dairy, Dovecoat, Stable, Barn, Hen house Kitchen & all conveniencys, & all in a manner new, a large Orchard of about 2500 Apple trees most grafted, well fenced with a Locust fence, which is as durable as most brick walls, a Garden a hundred foot square, well pailed in, a Yeard wherein is most of the foresaid necessary houses, pallizado'd in with locust Punchens, which is as good as if it were walled in, & more lasting than any of our bricks, together with a good Stock of Cattle hogs horses, Mares, sheep &c, & necessary servants belonging to it, for the supply and support thereof. About a mile & half distance a good water Grist miln, whose tole I find sufficient to find my own family with wheat & Indian corn for our necessitys & occasions Up the River in this Country three tracts of land more, one of them contains 21996 Acres another 500 acres, & one other 1000 Acres, all good convenient & commodious Seats, & wch. in a few years will yield a considerable annual Income. A Stock of Tobo. [tobacco] with the Crops & good debts lying out of about 250000lb. besides sufficient of almost all sorts of goods, to supply the family & the Quarter's occasions for two if not three years. Thus I have given you some particulars, which I thus deduce, the yearly Crops of corn & Tobo. together with the surplusage of meat more than will serve the family's use, will amount annually to 60000lb. . . . The Orchard in a very few years will yield a large supply to plentifull house keeping, or if better husbanded, yield at least 15000lb. (Letter to Dr. Ralph Smith, Virginia landowner and merchant, 22 April 1686; pp. 175-76)

Your generous & kind offer of more vegetables in any condition desired, either in seed, trees, slips or plants, agrees so naturally with my Constitution, & the melancholly Condition of this Country, that I must be of all men the most ungratefull, if I should not meet with so great a favour from so good a friend. . . . (Letter to Nicholas Hayward, London friend and agent, 22 April 1686; p. 177)

I desire you to take care of the Delivery of the inclosed: I have only in my former sent for 100lb. of Sun dried Sugar, & about 60 or 80lb. of powdered Sugar. (Letter to John Cooper, London merchant, 1 June 1685; p. 195)

In particular letters to you both I ordered you money, & in my last particular letter I acquainted you that I would have what I had not there expressly dispos'd of, laid out for my use in plate, after having paid your selves the full ballance of your Accts, the plate that I would have bought pray let it be plain & strong, being in these particulars following, if my money will reach to it, but rather leave some out, than bring me a penny in Debt One dozen silver hafted knives. 1 doz: silver forks One dozen silver spoons large & strong. 1 set Castors One 3 quart Tankard. . . . One Silver Salvator plate Four silver porringers 2 indifferent large, 2 small ones A small silver bason, 1 doz. Silver plates. Four Silver Dishes 2 pretty large for a good joint of meat, & two of a smaller sort, if my money falls short let it be wanting in the Dishes, if there be any remaining let the Overplus be what it will, laid out in silver plates & let it all be thus marked W F S & that Coat of Arms put upon all pieces that are proper, especially the Dishes, plates & Tankards &c. that I have sent enclosed and blazoned in a letter to Mr. Hayward. (Letter to John Cooper and Nicholas Hayward, London merchants, 1 June 1688; p. 244)

. . . I still continue my resolutions of purchasing the same pieces of Plate, & particularly the knives which I have already forks for, when they come to hand, which I desire you'll please to purchase for me according to my last years direction, with the addition of a Silver ladle. . . . (Letter to Nicholas Hayward, London merchant, 1 April 1689; pp. 249-50)

. . . though I last year mentioned the plate, yet now I think it convenient to mention it again (viz) Two Silver Dishes weighing 50 oz. a piece or thereabouts, two Ditto weighing 70 oz. a piece or thereabouts, a Sett of Castors that is to say for Sugar, Pepper and Mustard about 24 or 26 oz. a basin betwixt 40 & 45 oz. a Salver about 30 oz. a pair of Candlesticks about 30 oz. a ladle about 10 oz. a Case containing a dozen silver hafted knives, & a dozen silver hafted forks answerable, what remains if any, let it be laid out in a large Salt, & what else you think convenient. (Letter to Nicholas Hayward, London agent, 6 May 1689; p. 258)

. . . your Brother has been carefully diligent, in providing & graffing trees for orcharding there truly effects are not answerable to the services done, for want of care in the Inhabitant there, for without a constant care & diligent Eye, a well made plantation will run to

Ruin, what a new made plantation will arrive where that's wanting, (which hitherto has been your unfortunacy in this Country concerns) I leave your self to judge, And what in my former letter I severall times inculcated, Sr. Preparation for an Orchard is soon made, & that as soon planted, but without a constant care & continuall residence thereupon, the labour & care of seven years is destroyed in as many hours. . . . My Orchard I must confess, contributes largely to my present supply, & gives me from its loaden boughs a promised assurance of a future gratification which I'll assure we never chearfully pass about yor. self unremembred. (Letter to Nicholas Hayward, London agent, 20 May 1691; pp. 291-92)

In my next shall write at large have nothing to say farther, more than to desire you to buy me two large Silver Dishes, one dozen Silver plates a pair large Candlesticks, snuffers, & stand, two bread plates, & two small Silver chafing dishes. . . . (Letter to Nicholas Hayward, London agent, [Spring 1697?]; p. 344)

[From an inventory of Fitzhugh's estate:]

PLATE

Six silver Dishes 2 silver Basons 2 dozn. Silver Plates
4 Silver Porringers 3 Casters 3 Salvers 3 Silver
Tankards . . . 6 Silver Trencher[s] Salts 1 Table Salt 1.
Dozn. Silver hafted Knifes 1 Dozen Silver Forks 1 Silver
Ladle 2 Tumblers 1 Dozn. Silver Spoons . . . 1 Silver
Cork Screw 2 Silver Dishes 1 Doz: Silver Spoons 1 Bason
or Bunch Bowl 1 C[h]ocolate Cup 3 Silver Salts. in all 122
pieces of Plate. . . . (p. 382)

HOUSEHOLD FURNITURE

. . . 8 pair Andirons 20 Pewter Dishes 5 Doz & 4 Pewter
Plates 1 great Brass Dish 1 Copper Sestern . . . 1
Copper. Chocolate Pott 2 Skillets or stew pans 2 Possnets
2 stands to set Plates upon . . . 2 Kettles 4 Iron Potts 4
Spitts 6 old Kettles 1 Brass Mortar 1 Stone Do. . . . (p.
384)

[Some food items and vessels ordered from merchants by
William Fitzhugh:]

Claret & white sugar (19 June 1681, p. 96)

a hamper of Canary . . . 3 dozen Gallon Stone jugs (22
May 1683, p. 143)

a hundred of Gloucestershire Cheese (21 June 1692, p. 301)

a handsome quantity of fruit & spice (11 May 1697, p. 352)

Two gall: Florence Oyl (26 July 1698, p. 367)

[1679-1680].

Journal of Jasper Danckaerts 1679-1680. Ed. Bartlett Burleigh James and J. Franklin Jameson. 1913; rpt. New York: Barnes and Noble, 1952.

[Danckaerts' journal includes descriptions of his travels through Maryland. Most of the journeying, lodging, and eating was rough and comfortless, although Danckaerts encountered many kind and hospitable people as he struggled through the primitive country.]

[6 December 1679.] We arrived . . . at the plantation of Mr. Hopkins, who was not at home. Being fatigued, and not having yet breakfasted, we asked for something to drink that clear water from, and afterwards for something to eat; but we could obtain nothing except a piece of maize bread with which we satisfied ourselves. . . . But we found [in the afternoon] a good old woman who immediately put before us something to eat, and gave us some exceedingly good cider to drink. (p. 117)

[7 December 1679.] We found Mr. Commegys on the next plantation, who bade us welcome, and after we had drunk some cider, accompanied us with one of his company to Mr. Hosier's . . . Something was immediately set before Mr. Commegys and ourselves to eat, in which the wife manifested as much kindness as the husband. This was not unacceptable, for we had eaten nothing all day. (p. 119)

[10 December 1679. Richard Adams] gave us some French brandy to drink, which he had purchased of the captains of the ships who had brought it from England; but as it was an article prohibited on pain of forfeiture, it was not to be bought here. . . .

I have nowhere seen so many ducks together as were in the creek in front of this house. . . . There was a boy about twelve years old who took aim at them from the shore, not being able to get within good shooting distance of them, but nevertheless shot loosely before they flew away, and hit only three of four, complained of his shot,

as they are accustomed to shoot from six to twelve and even eighteen and more at one shot. After supper we ate some Maryland or Virginia oysters which he had brought up with him. We found them good, but the Gouanes oysters at New York are better. (p. 123)

[12 December 1679. A Quaker living in a crude shed] had nothing to eat but maize bread which was poor enough, and some small wild beans boiled in water. . . . (p. 129)

[13 December 1679. At Apoquemene we] stepped into a house and were welcome. Some food was immediately set before us to eat, and among other things butter, cheese, and rye bread which was fresh and so delicious that my companion said it was to him like sweet cake. (p. 130)

[15 December 1679.] The servants and negroes after they have worn themselves down the whole day, and come home to rest, have yet to grind and pound the grain, which is generally maize, for their masters and all their families as well as themselves, and all the negroes, to eat. . . . As to articles of food, the only bread they have is that made of Turkish wheat or maize, and that is miserable. They plant this grain for that purpose everywhere. It yields well, not a hundred, but five or six hundred for one; but it takes up so much space, as it is planted far apart like vines in France. This grain, when it is to be used for men or for similar purposes, has to be first soaked, before it is ground or pounded, because the grains being large and very hard, cannot be broken under the small stones of their light hand-mills; and then it is left so coarse it must be sifted. They take the finest for bread, and the other for different kinds of groats, which, when it is cooked, is called *sapaen* or *homina*. The meal intended for bread is kneaded moist without leaven or yeast, salt or grease, and generally comes out of the oven so that it will hardly hold together, and so blue and moist that it is as heavy as dough; yet the best of it when cut and roasted, tastes almost like warm white bread, at least it then seemed to us so. (pp. 133-34)

A few vegetables are planted, but they are of the coarsest kinds and are cultivated in the coarsest manner, without knowledge or care, and they are, therefore, not properly raised, and do not amount to much as regards the production, and still less as to their use. Some have begun to plant orchards, which all bear very well, but are not properly cultivated. The fruit is for the greater part pressed, and makes good cider, of which the largest

portion becomes soured and spoiled through their ignorance or negligence, either from not putting it into good casks, or from not taking proper care of the liquor afterwards. Sheep they have none, although they have what is requisite for them if they chose. It is matter of conjecture whether you will find any milk or butter even in summer; we have not found any there at this season of the year. (pp. 134-35)

When the ships arrive with goods, and especially with liquors, such as wine and brandy, they attract everybody, that is, masters, to them, who then indulge so abominably together, that they keep nothing for the rest of the year, yea, do not go away as long as there is any left, or bring anything home with them which might be useful to them in their subsequent necessities. (p. 135)

[30 December 1679. Some Indians] offered us some boiled beans in a calabash, cooked without salt or grease, though they brought us our own kind of spoons to take them out with. [The queen] gave us also a piece of their bread, that is, pounded maize kneaded into a cake and baked under the ashes. (p. 159)

[1684-1691].

[William Byrd]. *The Correspondence of the Three William Byrds of Westover, Virginia, 1684-1776*. Ed. Marion Tinling. Vol. I. Virginia Historical Society Documents, Vol. 12. Charlottesville: Univ. Press of Virginia, 1977.

I desire you would send mee two new fashion'd silver mugs one to contain about 1/2 pint & the other about 1/4 of a pint, both for my selfe. . . . (Letter to Robert Coe, London goldsmith, 20 May 1684; p. 20)

[T]hanks for your goosberry, currans & flowers, the latter whereof miscarryed. The shrubs are all alive & grow well. (Letter to Nordest Rand, 21 May 1684; p. 22)

I have lately been at a great trouble & charge in building 2 grist mills & therefore intreat you (if it bee possible) to procure mee one or two honest millers, though I should bee at some more than ordinary charge about them. (Letter to Warham Horsmanden, Byrd's father-in-law, 24 or 31 March 1684/5; p. 32)

Pray send mee some Savoy cabbage seed. (Letter to Thomas Gower, 31 March 1685; p. 37)

Pray lett care bee taken about the caske for rum & molasses, for wee sufferd great losse by the last. Though mine escaped the best, yett I lost all the limejuice, one caske of rum wholly out, many others 1/2 and 1/4. I hope suddenly to send you a few barrells of flower for a sample, next year hope to provide better, being yet in want of a bolting mill & other conveniencys. . . .

I desire these following goods may bee sent on my particular account, vizt. . . .

3000 lbs. muscovado sugar

1 barrell of white about 2 [cwt.]

3 tun of molasses

1 caske limejuice & 2 [cwt.] ginger.

(Letter to Sadler & Thomas, Barbados merchants, 10 Feb. 1685/6; pp. 50-51)

The white sugar very bad, I bought better here at 19s. & 6d. per [cwt.?] the limejuice was not worth one farthing, all the rest of the goods very dear, as all other affirme that had goods from Barbados at that time. I doubt not but you will hear of itt largely from others. Our designe was to have sent the ship immediately backe to you with corne, pipe staves &ca. . . . [Wyn's] wheat is now all ready, & wee designe shall bee at one place ere his return. I desire you to send mee the goods underwritten, but pray lett the rum mellasses & sugar bee all in barrels, which are much fitter for sale here then great caskes. You will receive herewith from mee 12 hogsheads of corne 8 barrells of flower & about 2500 pipe staves. . . .

I desire these following goods to bee sent on my particular account vizt.

1200 gallons rum

3000 muscovado sugar

1 barrell of white, about 2 cwt lett it bee better then last year

2 tun of mellasses

1 caske limejuice, 2 [cwt] ginger

(Letter to Sadler & Thomas, Barbados merchants, 18 Oct. 1686; pp. 64-65)

I have here sent you some sassafras berrys with some acorns and other kinds of seed; and tho theyre but few I hope they are rarity enough to be worth your acceptance. (Letter to Dr. Hans Sloane, naturalist, c. March 1687?; p. 71)

Invoice of sundry good & merchandizes sent for by me William Byrd to Messrs. John Thomas & Company merchants in Barbados for my particuler account & risque vizt.:

4000 gallons of rum:

5000 of muscovado: sugar or rather 6000
 8 or 10 tun of molasses:
 1 barrell of about 2 cwt. of whitt sugar
 Let the rum & shugar & mellasse be all in small caske & if possible least halfe the sugar & mollasses by the first convenience for James River for I am now in want. (Letter to John Thomas & Co., Barbados merchants, 16 April 1688; p. 75)

Goods I desire from Barbados are 1600 gallons rum 4000 lbs. muscovado sugar about 2 cwt. loaf sugar. (Letter to Perry & Lane, London agents, 11 Dec. 1688; p. 89)

In October last I received a list of some seeds & nuts from my Lord Effingham, who desired mee to procure them for you & though nothing could have oblidgeed my diligence more then to serve you, yet the season of the year being past itt was impossible for mee to procure them, onely some walnuts & hickery nuts of both kinds with the pishamin seed. . . . (Letter to Thomas Methwold, 5 March 1688/9; pp. 97-98)

That hogshead claret I had home is not near so good as that clarett you sent Capt. Randolph, whats at towne is not yet open'd. (Letter to Arthur North, London merchant, 6 March 1688/9; p. 101)

Please to send mee some ratsbane for they doe mee infinite mischief in all my stores, allso 20 lb. brimstone & 2 qts. Queen of Hungarys water. . . . (Letter to Perry & Lane, London agents, 23 July 1689; p. 110)

By my last I desire you by the first oppertunity to send mee about 2 cwt[?] ordinary loafe sugar, 1 chest oranges & about 20 cwt[?] of muscovado sugar in large barrells. (Letter to Jonathan Walke, Barbados merchant, 29 May 1690; p. 113)

Some time since I received a letter from Mr. Sergeant with a pipe of wine, 50 pales & a barrell of cranberrys shipd by your order. (Letter to Eliakim Hutchinson, 32 Jan. 1690/1; p. 143)

About 2 cwt. loafe sugar, 1 chest oranges 6 [lb.?] chocolate, 40 cwt. muscovado sugar the rest rum. (Letter to Jonathan Walke, Barbados merchant, 23 Jan. 1690/1; p. 144)

I desired you formerly to send mee a chest of oranges, & some chocolate 6 or 8 lbs. [?] if that's good, & with them I desire you to send mee two or three bottles of orange flower water, some of your best suckets & another barrell of refined sugar, as soon as oppertunity permits. . . . (Letter to Jonathan Walke, Barbados merchant, 20 May 1691; p. 147)

If you have an oppertunity I desire you to send mee 3 or 4 halfe aunes of Rhenish wine from Rotterdam, for that I had two years since from Mr. Senserf proved so well, that I have been desired by severall to procure some as good. (Letter to Perry & Lane, London agents, 3 June 1691; p. 153)

I would allso desire you to send mee to bee left att James City att Mr. Gaulers 20 or 30 dozen of clarett or other fashionable wine thats very good, 6 dozen canary, 6 dozen of sherry, & 6 dozen of Rhenish, with one quarter caske of brandy, & 6 gross good pipes. (Letter to Perry & Lane, London merchants, 4 June 1691; p. 155)

[1684-1694].

The Reverend John Clayton, A Parson with a Scientific Mind: His Scientific Writings and Other Related Papers. Ed. Edmund Berkeley and Dorothy Smith Berkeley. Virginia Historical Society Documents, Vol. 6. Charlottesville: Univ. Press of Virginia, 1965.

. . . Ordinarys ie our Inns are extreame expensive wherefore with a comon impudence they'le goe to a mans house for diet & lodgeings tho they have no acquaintance at all rather than be at the expence to lie at an Inn & being grown into rank custom it makes them seem liberall. . . . (p. 4, from a letter dated 24 April 1684)

[The Indians] are almost allways either eating or sleeping unless when they go a Hunting, at all hours of the night whenever they are awake they go to the *Hominy-pot*, that is, maze dressed in a manner like our pilled wheat [i.e., peeled or pared off or with the hull removed], or else a piece of Venison *barbecuted*, that is wrapped up in leaves & roasted in the Embers. (p. 37, from letter dated 1687)

There be wild Turkies [*Meleagris gallopavo*] extreme large they talk of Turkies that have been killd that have weighd betwixt fifty & Sixty pound weight. The largest that ever I saw weighd somthing better than 38 pound they have very long leggs & will run prodigiously fast. . . .

Partridges [bobwhite, *Colinus virginianus*] there are much smaller than ours, & resort in Covies as ours do; their flesh is very white & much excels ours in my mind sed de gustibus non est disputandum. (p. 97, from letter printed in 1693)

Wild Bulls, & Cows, there are now in the uninhabited parts, but such only as have been bred from some that have strayed, & become wild, & have propagated their kind, & are difficult to be shott, having a great acuteness of smelling. The common rate of a Cow, & Calfe, is 50s, sight unseene, be she bigg, or little, they are never very curious to examine that point.

Their *Sheep* are of a midling size, pretty fine fleeced in general, & most persons of Estate begin to keep flocks, which hitherto has not been much regarded, because of the Wolves that destroy them so that a piece of mutton is a finer Treat, than either Venison, wild-goose, Duck, Wigeon, or Teale. . . .

Deare, there are abundance of brave red Deare, so that a good woodsman as they call them, will keep a house with Venison . . .

Swine, they have now in great abundance Shoats, or Porkrels, are their general food. And I believe as good as any Westphalia certainly far exceeding our English. (p. 106-07, from manuscript dated 1694)

Beares there are, And yet but few in the Inhabited part of Virginia; toward Carolina there are many more. There was a small Beare kild within 3 miles of James City the year that I left the Country, but it was supposed to have strayed, & swame over James River. They are not very fierce, their flesh is commended for a very rich sort of Pork. . . . (p. 109, from manuscript dated 1694)

1687.

[Durand, of Dauphiné]. *A Huguenot Exile in Virginia: or Voyages of a Frenchman exiled for his Religion with a description of Virginia & Maryland*. Ed. Gilbert Chinard. The Hague, 1687; rpt. New York: Press of the Pioneers, 1934.

There are no lords, but each is sovereign on his own plantation. The gentlemen called Cavaliers are greatly esteemed & respected, & are very courteous & honorable. They hold most of the offices in the country. . . . (p. 110)

They dress as we do in France. Almost all of their clothes are brought ready-made from England. . . .

The land is so rich & so fertile that when a man has fifty acres of ground, two men-servants, a maid & some cattle, neither he nor his wife do anything but visit among their neighbors. Most of them do not even take the trouble to oversee the work of their slaves, for there is no house, however modest, where there is not what is called a Lieutenant, generally a freedman, under whose commands two servants are placed. (p. 111)

In this colony they sell more than twelve hundred thousand ecus' worth of tobacco, not including what they reserve for barter & their own use, & this every year, so that if out of that amount they bought only iron, tin, sugar, spices & brandy, they could walk upon gold. . . . As for food, it is more abundant than all else. . . . (pp. 112-13)

. . . as for Virginia & Maryland, if you but glance across the plains you will see them covered with lofty trees & lovely orchards of apples, pears, cherries, apricots, figs & peaches. (p. 114)

They usually plant tobacco, Indian corn, wheat, peas or beans, barley, sweet potatoes, turnips, which grow to a monstrous size & are very good to eat. They make gardens as we do in Europe. . . . Again the soil is so favorable for fruit-trees that I saw orchards planted, I was told, only ten years before, with larger & better grown trees than our twenty year old ones in Europe.

In the county of Gloucester wheat generally yields ten to one; Indian corn two hundred to one; the farmers reap only about a bushel of wheat each on their plantations for making pies, because of the great abundance of game & apples which make very good pies also. I asked why they did not grow more of it. They answered it yielded but ten to one, whereas Indian corn gave at least two hundred to one, & they were as healthy on this bread as they would be on that made of wheat. As for barley, they grow little of it, it yields eighteen to one; but they make so much cider, very different from Normandy cider, that if they knew how to manage, they would always have some left at the end of the year. In some places Indian corn yields as much as five hundred to one, which I could not have believed had I not seen it. Bread made of it is as white as paper & agreeable to the taste, but rather heavy on the stomach for those not used to it; nor can the dough be spread to make pies [Chinard suggests this is probably the "pone" or "bread made of Indian meal" mentioned by Beverley]. To mix it they bring water to

the oven door & there reknead the dough; when baked it slices like the other kind. Most people grind it in handmills, sift it & use only the choicest for making bread; there remains grains like fine rice, which make an excellent but somewhat indigestible soup. With this soup they feed the slaves, & it costs very little to maintain them, particularly the negroes, for in some places they are given bread & meat only on Christmas day. (pp. 115-17)

They sow wheat at the end of October & beginning of November, & corn at the end of April. This is the best grain to harvest, because those needing to can commence using it for bread at the beginning of September & the harvest is not over until the end of November. . . . They also plant two beans of an excellent kind, close to the four grains of corn whose stalks will serve them as poles to climb along. (p. 118)

As to wheat at M. Wormeley's plantations I saw the cows, horses & sheep grazing on it. (p. 119)

Some people in this country are comfortably housed. . . . Whatever their rank, & I know not why, they build only two rooms with some closets on the ground floor, & two rooms in the attic above; but they build several like this, according to their means. They build also a separate kitchen, a separate house for the Christian slaves, one for the negro slaves, & several to dry the tobacco, so that when you come to the home of a person of some means, you think you are entering a fairly large village. (pp. 119-20)

My host had only two young men-servants, no maid; he had bought one of those shameless hussies who came over at the time I did, & she had been ill ever since from work. He gathered ten bushels of wheat, two hundred of corn, having sown a bushel of each; fifteen bushels of beans, a quantity of sweet potatoes, perhaps fifty bushels of turnips had they been measured. . . . (pp. 120-21)

The domestic animals are exactly like those of Europe. They raise great numbers of horses, oxen, cows, sheep, pigs, turkeys, geese, ducks, chickens, & it costs nothing to keep or feed them. . . . Pigeons are raised only by people of quality, the common people scorning such small animals. . . . To make the cows return for milking, they keep the calves inclosed in an orchard; they take what milk they want & the calves suckle the rest. They make

excellent butter, but their cheese is no good. . . . As to cattle raised for food, however rapidly they may multiply, their number is kept down, for there is not a house so poor that they do not salt an ox, a cow & five or six large hogs. . . .

As for wild animals, there are such great numbers of red & fallow deer that you cannot enter a house without being served venison. It is very good in pies, boiled or baked. There are bears, also, but not many; there are beavers & raccoons, the meat of which is excellent. Hares are somewhat scarce; the rabbits are not unlike those of Europe. . . . There are also many doves, turtle-doves, thrushes, partridges in such numbers that they come into the court-yards; they are smaller than those of Europe, but taste the same. (pp. 122-23)

They also have bees, so they make wax candles & eat the honey.

Fish too is wonderfully plentiful; there are so many shell oysters that almost every Saturday my host craved them. He had only to send one of his servants in one of the small boats & two hours after ebb-tide he brought it back full. (p. 124)

There are also many chestnut trees & three varieties of walnut trees, their leaves & wood different from those of Europe. Their nuts cannot be shelled, but they would be good to make oil [Chinard suggests these were hickory nuts]. (p 125)

There are quantities of a kind of tree that bears fruit as large as apples. Its flavor is excellent & it is pleasant to see [probably what Beverley describes as the "persimmon," according to Chinard]. There are also fig trees that bear black, red, & white fruit, & grape-vines are found in greater abundance along the seashore & rivers than in the woods. They encircle around five or six trees & bear quantities of grapes, but the grapes are small as if the vines were never pruned or cultivated. I found some wild grapes close to my room. I had my servant pick them & made ten or twelve jugs of juice which I left to ferment, & it was very good. But I saw most of them in the county of Rappahannock & Estaford [Stafford], chiefly on the Wormeley plantations, along the southern shore of the river. They are not cultivated; & the savages had left peach & plum trees, but cut the rest, so that the vines encircled the trees near them, & when they found no more, they stretched along the ground, between the stones & buried themselves in, in such a way

that they look as if they had been planted, & on the other shore it was the same thing, but the servants told me that when he established his plantations they had uprooted more than twenty cart-loads to plant tobacco. Good wine could certainly be obtained if on arriving the branches were pruned & cultivated; at least there would be enough for one's own use, & yet low grape-vines could be planted, the wine would be better, & it would bring a very good income. There are many pears, apples, cherries, apricots & peaches on everyone's plantation. I have seen no olive trees, but if brought over they would thrive, for they can grow wherever live oaks grow. (pp. 126-27)

Everywhere we were required to drink so freely that even if there were twenty, all would drink to a stranger & he must pledge them all. They drank also some bottles of a rum much stronger than brandy. When they were not intoxicated they usually let me drink in my own way, & generally I just kissed the glass; but when they were drunk they would have me drink at their will. This so much annoyed me that as soon as I had a room, I went no more. The cider made me ill; I think this was because it was too new. Their water also made me ill. . . . (p. 129)

On his wedding-day, [a French boy from Abeville in Picardy] sent two of his father-in-law's negroes for me in a boat, & I went by water. The Indians [colonists born in America] make a great festival of a wedding. There were at least a hundred guests, many of social standing, & handsome, well-dressed ladies. Although it was November, we ate under the trees. The day was perfect. We were twenty-four at the first table. They served us so copiously with meats of all kinds that I am sure there would have been enough for a regiment of five hundred soldiers. . . . The Indians [colonists] eat almost no bread, seldom drink during meals; but they did nothing afterwards, for the rest of the day & all night, but drink, smoke, sing & dance. They had no wine; they drank beer, cider, & punch, a mixture prepared in a large bowl. They put in three jugs of beer, three jugs of brandy, three pounds of sugar, some nutmegs & cinnamon, mix these well together & when the sugar has melted they drink it, & while making away with the first, they prepare another bowl of it. As for me, I drank beer only, cider makes me ill and I do not care for sugar. It is the custom to take only one meal upon such occasions, at two o'clock in the afternoon. (pp. 137-38)

. . . we took our meals once a day with the Governor, at two o'clock in the afternoon. This is the only meal he takes regularly at home, the others at Monsieur Wormeley's. He had us served white wine from Spain and claret from Portugal, & Monsieur Wormeley wine from Portugal, cider & beer. As it was now nearly five months that I had drunk nothing but water, I found these wines so strong that I asked leave to dilute them with an equal quantity of water. (p. 147)

The launch had brought [to Wormeley's plantation] all kinds of supplies except meat, which she was to carry back. The gentlemen immediately had bowls of punch prepared, & they began to carouse. . . . (p. 151)

[Fitzhugh] treated us royally, there was good wine & all kinds of beverages, so there was a great deal of carousing. He had sent for three fiddlers, a jester, a tight-rope dancer, an acrobat who tumbled around, & they gave us all the entertainment one could wish for. (p. 158)

If I sent corn to their mills [on the Rappahannock] they shamelessly kept half of it. . . . (p. 163)

1701-1702.

Francis Louis Michel. "Report of the Journey of Francis Louis Michel from Berne, Switzerland, to Virginia, October 2, 1701-December 1, 1702. Trans. and ed. William J. Hinke. *The Virginia Magazine of History and Biography*. 24 (Jan., Apr. 1916), 1-43, 113-41.

Food [on the voyage from Europe to Virginia] was henceforth distributed in the following manner: Five passengers had to club together. They received daily four pounds of biscuit, one quart of beer, two quarts of water, two pieces of beef and pork, weighing six pounds, in addition every noon, which was mealtime and announced by the ringing of bells, a dish full of large peas. On Sundays and Wednesdays we received in place of the meat two pounds of flour and half a pound of pork lard, out of which a thick paste is made, which is put into a linen sack. It is cooked with the meat, but not as long as the latter. Grape juice is often put into it, which is a good dish, called boudin [pudding]. It happens often that instead of meat fresh and large beans with butter are given out. The food is often, on account of the heat and because it is not salted sufficiently, like the water, of such bad taste that we suffered considerably, especially

because the large number of mice spoiled our bread altogether. The captain and those that eat at his table are always supplied with fresh meat, nor do they use wine and strong beer sparingly. It cost ten pounds for the journey outwards and six pounds for the return trip to eat at his table, besides the transportation fare. (pp. 10-11)

Forty bottles of whiskey were ready to fill the people with courage. . . . With great trouble and cost I had a pitcher of ptisan [in French *tisane*, from the Greek *ptisane*, meaning peeled barley and also barley water] cooked for me. . . . (p. 14)

As to corn, the "Wirde" or Turkish corn is grown in most cases. It is so productive that it yields fifty to a hundred fold. It makes pretty good bread. It is also pounded and cooked, called humin [hominy]. Its flour is taken and cooked thick in water. Then it is put into milk. It is mostly the food of servants. The flour is also frequently taken and a thick dough is made out of it with water. Then, by means of a hot fire and many coals, it is baked in a little while. (p. 31)

The other kind [of grain] is wheat, which is planted by every family for its use, in such places where the cattle have been penned in at night. . . .

Barley and oats are also planted and they turn out well usually. The inhabitants pay little attention to garden plants, except lettuce, although most everything grows here. But fresh seeds must be imported every year from Europe, for, if the seed of this country is planted, it turns into the wild kind again.

The custom of the country, when the harvest is to be gathered in, is to prepare a dinner, to which the neighbors are invited, and for which two men have sufficient work to do. There are often from thirty to fifty persons cutting grain, so that frequently they have work for only two hours.

This is one of the principal festivals or times of rejoicing. . . . Fresh meat cannot be kept in summer longer than twenty-four hours, hence [when rain prevented a wheat harvest which was to have been followed by a dinner] the good people were compelled, if they did not want to let the sheep and chicken, which they had prepared, spoil, to entertain us, which lasted for a day and a half.

Fruit trees are growing in great abundance. . . . The apple trees are very numerous, most of them not very

large nor high, like pear trees. But they are exceedingly fruitful. I was at many places this year, where I could not estimate the large quantities which were rotting. They are the nicest apples that can be seen. There is a kind somewhat earlier than the others, they are called Cattalines. They are pointed and of a sour taste. The summer cider is made of them. A later kind is valued more highly and, like the first, cider is made of them, which keeps longer than the other. . . . It is drunk mostly during the winter. As the common man does not have good cellars, this drink cannot be kept during the summer, but it turns sour. There are also pears of all kinds, but they are not as common as the apples. There are several kinds of peaches, and in such quantities that people cannot eat the fourth part of them. The rest is fed to the pigs. It should be noted that this fruit ripens in a few days. Cherries, especially the cultivated cherries, are found in great abundance, where they are planted. Good wine is made of them.

All kinds of berries grow in the wilderness and also on the plantations, in such abundance that it cannot be estimated. There are also many different kinds, namely of black and white color. The best are brown, long and large. This berry is largely eaten by pigs and birds. Whoever has a desire for berries, does not need to buy them or ask for them, for the abundance is so great that no one pays any attention to them, nor are they used very much, because people do not want to take the trouble to pick them, as they have enough other food.

There are also plums, but they are not common. Also many other kinds of fruit, but they are not known to me. There is, especially among the garden plants, a certain kind of beans, not unlike the Turkish, which is planted with the Indian corn. It grows up along the stalks and is very productive. It is nourishing food. There is another kind which creeps on the ground. There are also different kinds of peas, planted in the gardens, but growing also outside of them. Besides, there are potatoes in great quantities and many kinds of melons. Some are cooked, others, like the water melons, are eaten raw, since this fruit is very refreshing in the hot summer because of its cool, sweet juice. They are grown in great quantities and one can get as many as he desires.

The water is no less prolific, because an indescribably large number of big and little fish are found in the many creeks, as well as in the large rivers. The abundance is so great and they are so easily caught that I was much surprized. Many fish are dried, especially those that are fat. . . . They cannot be compared with our fish, except

the herring, which is caught and dried in large numbers. Thus the so-called catfish is not unlike the large turbot. A very good fish and one easily caught is the eel, also like those here [in Switzerland]. There is also a kind like the pike. They have a long and pointed mouth, with which they like to bite into the hook. . . . The [larger] waters and especially the tributaries are filled with turtles. They show themselves in large numbers when it is warm. Then they come to the land or climb up on pieces of wood or trees lying in the water. When one travels in a ship, their heads can be seen everywhere coming out of the water. The abundance of oysters is incredible. There are whole banks of them so that the ships must avoid them. . . . They surpass those in England by far in size, indeed they are four times as large. I often cut them in two, before I could put them into my mouth. The inhabitants usually catch them on Saturday. It is not troublesome. A pair of wooden tongs is needed. Below they are wide, tipped with iron. At the time of the ebb they row to the beds and with the long tongs they reach down to the bottom. They pinch them together tightly and then pull or tear up that which has been seized. They usually pull from six to ten times. In summer they are not very good, but unhealthy and can cause fever. (pp. 32-35)

Horned cattle are found in large numbers, so that in summer time much milk is used. Butter is also made as much as is needed. But most of the people know nothing of cheese. There were a few who undertook to make it. It was good but could not be compared to ours. The common farmer has usually from ten to forty heads of cattle. The gentlemen have about a hundred. . . .

Pigs are found there in such numbers that I was astonished. They are not large, but increase so rapidly that their number becomes large in a short time. Their meat or pork is considered by everybody as the best and most delicate. Many are taken every year alive to England. As they are fed with nuts, acorns, berries, apples and corn, they cannot be less than the best. They must be better than those which are fed with poorer food. This is shown by the Carolina ham, which smells after fish, because the pigs there are fed with fish. . . .

Sheep are raised in constantly increasing numbers. They thrive well. But, as the necessary workmen are wanting to use the wool, they are kept only for their meat. (pp. 36-37)

The feathered game is very common and tame. The first is properly the eagle. Then comes the turkey, whose number is very great. It is a large bird, which weighs from twenty to forty pounds. Many of them are shot because of the fine meat. . . . Partridges are also numerous and tame. It is not an uncommon sight to see them eating with the chickens. They are smaller, but excel them in the fineness of their meat. I was surprized to see them sitting on trees and hear them sing. I have shot many of them for their good meat and because they are found everywhere, but never only one of them. (p. 38)

[Summer rains] are usually warm and the sun has such power that, when something is planted, it grows in a short time. It is astonishing to see a thing half grown or half ripe one day, reaching ripeness in a few days. The fruits are all ripe much earlier than in this country [Switzerland]. . . . Their water is not inferior to ours. If one desires a drink at that time, half a vessel of cold water is taken, sugar is put in with some vinegar and nutmeg, together with some good glasses full of rum. At times they mix in some lemon. It is a good drink. One could easily get drunk from it. It is called Pons [punch]. . . .

Terrible winds, called hurricanes frequently come with such violence and force that people often fear that houses and trees will have to give way. But they are soon over. One can see and hear them come. Corn and other grain is often blown off the fields. . . . There is as much wood as one desires at the door. . . . There is, furthermore, a kind of wood or spice of saffran color, whose name I have forgotten. This wood is cut into chips. They are cooked afterwards and drunk. Every year much of it is exported to England. . . . [Walnut trees] bear a fruit like our beech trees, but larger. It cannot be opened without a nail. The pigs usually eat them. There are chestnuts at some places, but they are small. (pp. 40-41)

[The meat of tamed wild horses] is good to eat. . . .

Turtles of different kinds are found in the woods. They are gathered and eaten by the negroes or slaves. . . . There is especially a small species, which is found in large numbers on roads, mostly of a yellow color. They are most beautifully decorated. I took one of them with me and used it on board of ship as a drinking cup. (pp. 42-43)

After we had passed through the forest for several miles [on the Gloucester side of the York], we saw at our right and left plantations or farms (for as already indicated people do not live closely together, but each one selects a suitable place, where he finds good soil, pasture and water.) Finally we became curious to know how the houses looked inside and what food people were eating. We entered one which stood near the road, but no one was at home, except the maid servant, whom we asked for some water. She gave us also some food, a species of small white beans, cooked with bacon, which had been prepared for the overseers of the slaves. It was good. The food prepared for the negroes that work was pounded Turkish maize, cooked in water, called hominy, a healthy food. The bread was made of the above-mentioned corn, baked on the fire. We did not like it very much and could hardly eat it. The bread, baked in an oven, is better. Bread is also made of wheat, but not for the slaves or servants. (p. 114)

At first we were too modest to go into the houses to ask for food and lodging, which the people often recognized, and they admonished us not to be bashful, as this was the custom of rich and poor. (p. 115)

There are many people who have plantations for rent. Two to five pounds secures a good dwelling, and as much land as one can work. Most of the wealth consists in slaves or negroes, for if one has many workmen, much food-stuff and tobacco can be produced. (p. 116)

Before leaving [the Governor in Williamsburg] he ordered dinner to be served to us, with command to treat us well. . . . They gave us soup with fresh ham and some small beer. But the butler took us into the cellar, filled with all sorts of strange drinks. He gave us some English stout, very strong, afterwards Rhine wine. (pp. 118-19)

. . . we shot turtle-doves which are found there in large numbers, together with some partridges. (p. 121)

I have seen [above the falls of the James River] the most awful wild grapevines, whose thickness and height are incredible. There are several kinds of grapes, the best are as large as a small nut. They make fairly good wine, a beginning has been made to graft them, the prospects are fine. It is much healthier there than towards the ocean. The country is full of game and fish. The Indians often visit there, bringing game, rum and other

smaller things. . . . They often bring pottery and when desired fill it with corn. (p. 123)

It is indeed said truthfully that there is no other country, where it is possible with so few means and so easily to make an honest living and be in easy circumstances. For two servants can raise a bigger crop than one needs; the cattle increase incredibly fast without trouble; fruit grows in abundance. When a tree or something else is planted one must be surprised to see it grow up so soon and bear fruit. Besides, in the gardens grows whatever one desires. The cows are pasturing round about the house during the whole year. They yield enough butter, cheese and milk. In addition there is no lack of game and fish. (p. 124)

[T]he Governor caused most of those present, i. e., the most prominent people, to be entertained right royally, the ordinary persons received each a glass of rum or brandy with sugar. (p. 127)

When strangers come to [the Indians], they entertain them according to the best of their ability, with roasted game, wild fruits, fish and a kind of food, made of coarse and fresh meal. If one does not want to eat what they place before him, they say he is sick, but if they notice that this is not the case, but that it is done through contempt, they are angry. I once saw one of them eating this kind of meal. Then I also took some of it, raw as it was, out of the sack, which he had carried around with him, and I tried to eat the dry, coarse meal with a little stick of wood or knife, but I could not eat it, because it was so bitter and of unpleasant taste in the mouth. When they have taken a mouthful, they do not open it again, until all has gone down the throat. (pp. 132-33)

One must, however, be surprized when lodging with poor people, for better food is frequently met with there than among the rich. At other places where I stayed I exchanged merchandise for food, and thus supplied myself with provisions. There is little opportunity to sell eatables, except in harbors and in inns. At these places it is expensive, for a meal usually costs a shilling. (p. 140)

1705.

Robert Beverley. *The History and Present State of Virginia*. Ed. Louis B. Wright. Chapel Hill: Univ. of North Carolina Press, 1947.

These Rivers are made up, by the Conflux of an infinite Number of Chrystal Springs of cool and pleasant Water. . . . The Conveniencies of these Springs are so many, they are not to be number'd: I shall therefore content my self to mention that one of supplying the Country every-where, except in the low Lands, with as many Mills as they can find Work for: And some of these send forth such a Glut a Water, that in less than Half a Mile below the Fountain-head, they afford a Stream sufficient to supply a Grist-Mill; of which there are several Instances. (p. 121)

Of stoned Fruits, I have met with Three good Sorts, *viz.* Cherries, Plums, and Persimmons.

1. Of Cherries natural to the Country, and growing wild in the Woods, I have seen Three Sorts. Two of these grow upon Trees, as big as the common *English* white Oak, whereof one grows in Bunches like Grapes. Both these Sorts are black without, and but one of them red within; that which is red within, is more palatable than the *English* black Cherry, as being without its bitterness. The Other, which hangs on the Branch like Grapes, is Water-colour'd within, of a faintish Sweet, and greedily devour'd by the small Birds. The Third sort is call'd the *Indian* Cherry, and grows higher up in the Country, than the Others do. It is commonly found by the Sides of Rivers, and Branches, on small slender Trees, scarce able to support themselves, about the Bigness of the Peach-Trees in *England*. This is certainly the most delicious Cherry in the World; it is of a dark Purple when ripe, and grows upon a single Stalk, like the *English* Cherry, but is very small; though, I suppose, it may be made larger by Cultivation. . . .

2. The Plums which I have observ'd to grow wild there, are of Two sorts, the Black, and the Murrey Plum, both which are small, and have much the same Relish with the Damatine.

3. The Persimmon is by *Hariot* call'd the *Indian* Plum; and so *Smith*, *Purchase*, and *Du Lake*, call it after him; but I can't perceive that any of those Authors, had ever heard of the Sorts I have just now mention'd, they growing high up in the Country. These Persimmons amongst them retain their *Indian* Name. They are of several Sizes, between the Bigness of a Damatine and a Burgamot Pear. The Taste of them is so very rough, it is not to be endured, till they are fully ripe, and then they are a pleasant Fruit. Of these some *Vertuosi* make an agreeable kind of Beer; to which Purpose they dry them in Cakes, and lay them up for Use. These, like most

other Fruits there, grow as thick upon the Trees, as Ropes of Onions; the Branches very often break down by the mighty Weight of the Fruit.

Of Berries there is a great Variety, and all very good in their Kinds. Our Mulberries are of Three sorts, two Black and one White; the long Black sort are the best, being about the Bigness of a Boy's Thumb; the other Two sorts are of the Shape of the *English* Mulberry, short and thick, but their Taste does not so generally please, being of a faintish Sweet, without any Tartness. They grow upon well spread, large bodied Trees, which run up surprizingly fast. These are the proper Food of the Silk-Worm.

2. There grow naturally Two Sorts of Currants, one red, and the other black, far more pleasant than those of the same Colour in *England*. They grow upon small Bushes.

3. There are Three Sorts of Hurts, or Huckleberries, upon Bushes, from Two to Ten Foot high. They grow in the Vallies and sunken Grounds, having different Relishes; but are all pleasing to the Taste. The largest sort grow upon the largest Bushes, and, I think, are the best Berries.

4. Cranberries grow in the low Lands, and barren sunken Grounds, upon low Bushes, like the Gooseberry, and are much of the same Size. They are of a lively Red, when ripe, and make very good Tarts. I believe, these are the Berries, which Capt. *Smith* compared to the *English* Gooseberry, and called *Raxcomens*; having, perhaps, seen some of them green, but none ripe.

5. The wild Raspberry is by some there, preferr'd to those, that were transplanted thither from *England*; but I cannot be of their Opinion.

6. Strawberries they have, as delicious as any in the World, and growing almost every where in the Woods, and Fields. They are eaten almost by all Creatures; and yet are so plentiful, that very few Persons take care to transplant them, but can find enough to fill their Baskets, when they have a mind, in the deserted old Fields. (pp. 129-31)

Grapes grow wild there in an incredible Plenty, and Variety; some of which are very sweet, and pleasant to the Taste, others rough and harsh, and, perhaps, fitter for Wine or Brandy. . . .

1. Two of these Sorts grow among the Sand-banks, upon the Edges of the low Grounds, and Islands next the Bay, and Sea. They grow thin in small Bunches, and

upon very low Vines. These are noble Grapes; and tho' they are wild in the Woods, are as large as the *Dutch* Gooseberry. One Species of them is white, the other purple, but both much alike in Flavour.

2. A Third Kind is produced throughout the whole Country, in the Swamps and Sides of Hills. These also grow upon small Vines, and in small Bunches; but are themselves as big as the *English* Bullace, and of a rank Taste when ripe, resembling the Smell of a Fox, from whence they are called Fox-Grapes. All these Three Sorts, when ripe, make admirable Tarts, being of a fleshy Substance, and perhaps, if rightly managed, might make good Raisins.

3. There are Two Species more, that are common to the whole Country, some of which are black, and some blue on the Outside, but are both red within. They grow upon vast large Vines, and bear very plentifully. The nice Observer might, perhaps, distinguish them into several Kinds, because they differ in Colour, Size, and Relish; but I shall divide them only into Two, viz. The early, and the late ripe. The early ripe common Grape is much larger, sweeter and better than the other. Of these some are quite black, and others blue. . . . (pp. 133-34)

The sixth Sort is far more palatable than the rest, and of the Size of the white Muscadine in *England*; but these are peculiar to the Frontiers, on the Heads of the Rivers. (p. 135)

The Honey and Sugar-Trees are likewise spontaneous, near the Heads of the Rivers. The Honey-Tree bears a thick swelling Pod, full of Honey, appearing at a Distance like the bending Pod of a Bean or Pea. The Sugar-Tree yields a kind of Sap or Juice, which by boiling is made into Sugar. This Juice is drawn out, by wounding the Trunk of the Tree, and placing a Receiver under the Wound. The *Indians* make One Pound of Sugar, out of Eight Pounds of the Liquor. Some of this Sugar I examined very carefully. It was bright and moist, with a large full Grain; the Sweetness of it being like that of good Muscovada. (p. 136)

The *James-Town* Weed (which resembles the Thorny Apple of *Peru*, and I take to be the Plant so call'd) is supposed to be one of the greatest Coolers in the World. This being an early Plant, was gather'd very young for a boil'd Salad, by some of the Soldiers sent thither, to pacifie the Troubles of *Bacon*; and some of them eat plentifully of it,

the Effect of which was a very pleasant Comedy; for they turn'd natural Fools upon it for several Days. . . . (p. 139)

Several Kinds of the Creeping Vines bearing Fruit, the *Indians* planted in their Gardens or Fields, because they would have Plenty of them always at hand; such as, Musk-melons, Water-melons, Pompions, Cushaws, Macocks, and Gourds.

1. Their Musk-melons resemble the large *Italian* Kind, and generally fill Four or Five Quarts.

2. Their Water-melons were much more large, and of several Kinds, distinguished by the Colour of their Meat and Seed; some are red, some yellow, and others white meated, and so of the Seed, some are yellow, some red, and some black; but these are never of different Colours in the same Melon. This Fruit the *Muscovites* call *Arpus*; the *Turks* and *Tartars*, *Karpus*, because they are extremely cooling: The *Persians* call them, *Hindnanes*, because they had the first Seed of them from the *Indies*. They are excellently good, and very pleasant to the Taste, as also to the Eye; having the Rind of a lively green Colour, streak'd and water'd, the Meat of a Carnation, and the Seed black, and shining, while it lies in the Melon.

3. Their Pompions I need not describe, but must say they are much larger and finer, than any I ever heard, of in *England*.

4. Their *Cushaws* are a kind of Pompion, of a bluish green Colour, streaked with White, when they are fit for Use. They are larger than the Pompions, and have a long narrow Neck: Perhaps this may be the *Ecushaw* of *T. Harriot*.

5. Their *Macocks* are a sort of *Melopepones*, or lesser sort of Pompion, of these they have great Variety, but the *Indian* Name *Macock* serves for all, which Name is still retain'd among them. Yet the *Clypeata* are sometimes call'd *Cymnels* (as are some others also) from the *Lenten* Cake of that Name, which many of them very much resemble. *Squash*, or *Squanter-Squash*, is their Name among the Northern *Indians*, and so they are call'd in *New-York*, and *New-England*. These being boil'd whole, when the Apple is young, and the Shell tender, and dished with Cream or Butter, relish very well with all sorts of Butcher's Meat, either fresh or salt. And whereas the Pompion is never eaten till it be ripe, these are never eaten after they are ripe.

6. The *Indians* never eat the Gourds, but plant them for other Uses. Yet the *Persians*, who likewise abound

with this sort of Fruit, eat the *Cucurbita Lagenaris*, which they call *Kabach*, boiling it while it is green, before it comes to it's full Maturity; For, when it is ripe, the Rind dries, and grows as hard as the Bark of a Tree, and the Meat within is so consumed, and dried away, that there is then nothing left but the Seed, which the *Indians* take clean out, and afterwards use the Shells instead of Flagons and Cups; as is done also in several other Parts of the World.

The *Maracock*, which is the Fruit of what we call the Passion Flower, our Natives did not take the Pains to plant, having enough of it growing every where; tho' they eat it with a great deal of Pleasure; this Fruit is about the Size of a Pullet's Egg.

Besides all these, our Natives had originally amongst them, *Indian* Corn, Peas, Beans, Potatoes, and Tobacco. (pp. 141-43)

The late ripe Corn is diversify'd by the Shape of the Grain only. . . . That therefore which makes the Distinction, is the Plumpness or Shrivelling of the Grain; the one looks as smooth, and as full as the early ripe Corn, and this they call *Flint-Corn*; the other has a larger Grain, and looks shrivell'd with a Dent on the Back of the Grain, as if it had never come to Perfection; and this they call *She-Corn*. This is esteem'd by the Planters, as the best for Increase, and is universally chosen by them for planting; yet I can't see, but that this also produces the *Flint-Corn*, accidentally among the other. . . .

The *Indians* sow'd Peas sometimes in the Intervals of the Rows of Corn, but more generally in a Patch of Ground by themselves. They have an unknown Variety of them, (but all of a Kidney-Shape) some of which I have met with wild. . . .

Their Potatoes are either red or white, about as long as a Boy's Leg, and sometimes as long and big as both the Leg and Thigh of a young Child, and very much resembling it in Shape. I take these Kinds to be the same with those, which are represented in the Herbals, to be *Spanish* Potatoes. I am sure, those call'd *English* or *Irish* Potatoes are nothing like these, either in Shape, Colour, or Taste. (pp. 144-45)

[The *Indians*'] cookery has nothing commendable in it, but that it is perform'd with little trouble. They have no other Sauce but a good Stomach, which they seldom want. They boil, broil, or tost all the Meat they eat, and it is very common with them to boil Fish as well as Flesh with

ther *Homony*; This is *Indian* Corn soaked, broken in a Mortar, husked, and then boil'd in Water over a gentle Fire, for ten or twelve hours, to the consistence of Firmity: The thin of this is, what my Lord *Bacon* calls Cream of Maize, and highly commends for an excellent sort of nutriment.

They have two ways of Broyling, *viz.* one by laying the Meat itself upon the Coals, the other by laying it upon Sticks rais'd upon Forks at some distance above the live Coals, which heats more gently, and dries up the Gravy; this they, and we also from them, call *Barbacueing*.

They skin and paunch all sorts of Quadrupeds; they draw, and pluck their Fowl; but their Fish they dress with their Scales on, without gutting; but in eating they leave the Scales, Entrails and Bones to be thrown away.

They never serve up different sorts of Victuals in one Dish; as Roast and Boil'd, Fish and Flesh; but always serve them up in several Vessels.

They bake their Bread either in Cakes before the Fire, or in Loaves on a warm Hearth, covering the Loaf first with Leaves, then with warm Ashes and afterwards with Coals over all. (p. 178)

[The Indians] make excellent Broth, of the Head and Umbles of a Deer, which they put into the Pot all bloody. This seems to resemble the *jus nigrum* of the *Spartans*, made with the Blood and Bowels of a Hare. They eat not the Brains with the Head, but dry, and reserve them to dress their Leather with.

They eat all sorts of Peas, Beans, and other Pulse, both parched and boiled. They make their Bread of the *Indian* Corn, Wild Oats, or the Seed of the Sunflower. But when they eat their Bread, they eat it alone, and not with their Meat.

They have no Salt among them, but for seasoning, use the Ashes of Hiccory, Stickweed, or some other Wood or Plant, affording a Salt ash.

They delight much to feed on Roasting-ears; that is, the *Indian* Corn, gathered green and milky, before it is grown to its full bigness, and roasted before the Fire, in the Ear. For the sake of this Dyet, which they love exceedingly, they are very careful to procure all the several sorts of *Indian* Corn before mentioned, by which means they contrive to prolong their Season. And indeed this is a very sweet and pleasing Food.

They have growing near their Towns, Peaches, Strawberries, Cushawes, Melons, Pompions, Macocks, &c. The Cushaws and Pompions they lay by, which will keep several months good after they are gather'd; they Peaches

they save, by drying them in the Sun; they have likewise several sorts of the *Phaseoli*.

In the Woods, they gather Chincapins, Chesnuts, Hiccories, and Walnuts. The Kernels of the Hiccories they beat in a Mortar with Water, and make a White Liquor like Milk, from whence they call our Milk *Hickory*. Hazlenuts they will not meddle with, tho they make a shift with Acorns sometimes, and eat all the other Fruits mentioned before, but they never eat any sort of Herbs or Leaves.

They make Food of another Fruit call'd *Cuttanimmons*, the Fruit of a kind of Arum, growing in the Mashes: They are like Boyl'd Peas, or Capers to look on, but of an insipid earth taste. Captain *Smith* in his History of *Virginia* calls them *Ocoughtanannis*, and *Theod. de Bry* in his Translation, *Sacquenumener*.

Out of the Ground they dig Trubbs, Earth-nuts, Wild Onions, and a Tuberous Root they call *Tuckahoe*, which while crude is of a very hot and virulent quality: but they can manage it so as in case of necessity, to make Bread of it, just as the *East Indians* and those of *Egypt*, are said to do of *Colocassia*. It grows like a Flagg in the miry Marshes, having Roots of the magnitude and taste of *Irish* Potatoes, which are easy to be dug up. (pp. 180-81)

Among all this variety of Food, Nature hath not taught [the Indians] the use of any other Drink than Water. . . . For their Strong drink, they are altogether beholding to us, and are so greedy of it, that most of them will be drunk as often as they find an opportunity. . . . (p. 182)

If [the Indians] carry any Flesh in their marches, they barbicue it, or rather dry it by degrees, at some distance, over the clear Coals of a Wood fire. . . . Their Sauce to this dry Meat, (if they have any besides a good Stomach) is only a little Bears Oly, or Oyl of Acorns; which last they force out, by boyling the Acorns in a strong Lye. Sometimes also in their Travels, each man takes with him a pint or quart of *Rockahomonie*, that is, the finest *Indian* Corn, parched, and beaten to powder. When they find their Stomach empty, (and cannot stay for the tedious Cookery of other things), they put about a spoonful of this into their Mouths, and drink a draught of Water upon it, which stays their Stomachs, and enables them to pursue their Journey without delay. But their main dependance is upon the Game they kill by the way, and the natural Fruits of the Earth. (p. 185)

The Male-Servants, and Slaves of both Sexes, are employed together in Tilling and Manuring the Ground, in Sowing and Planting Tobacco, Corn, &c. Some Distinction indeed is made between them in their Cloaths, and Food; but the Work of both, is no other than what the Overseers, the Freemen, and the Planters themselves do.

Sufficient Distinction is also made between the Female-Servants, and Slaves; for a White Woman is rarely or never put to work in the Ground, if she be good for any thing else: And to Discourage all Planters from using any Women so, their Law imposes the heaviest Taxes upon Female-Servants working in the Ground, while it suffers all other white Women to be absolutely exempted: Whereas on the other hand, it is a common thing to work a Woman Slave out of Doors; nor does the Law make any Distinction in her Taxes, whether her Work be Abroad, or at Home. (pp. 271-72)

Each Servant at his Freedom, receives of his Master fifteen Bushels of Corn, (which is sufficient for a whole year) and two new Suits of Cloaths, both Linnen and Woollen. . . . (p. 274)

I must not here omit doing Justice to the Goodness and Generosity of Colonel *Byrd*, toward these distressed *Hugonots*. . . . What Liberties has he not all along allow'd them, upon his own Plantations, to furnish themselves from thence with Corn, and other Necessaries? His Mills have been at their Service, to grind their Corn Toll-free. . . . (pp. 282-83)

All their Drudgeries of Cookery, Washing, Daries, &c. are perform'd in Offices detach'd from the Dwelling-Houses, which by this means are kept more cool and Sweet. (p. 290)

The Families being altogether on Country-Seats, they have their Graziers, Seedsmen, Gardiners, Brewers, Bakers, Butchers, and Cooks within themselves: they have a great Plenty and Variety of Provisions for their Table; and as for Spicery, and other things that the Country don't produce, they have constant supplies of 'em from *England*. The Gentry pretend to have their Victuals drest, and serv'd up as Nicely, as at the best Tables in *London*. (p. 291)

Their Fish is in vast plenty and variety, and extraordinary good in their kind. Beef and Pork are commonly sold there, from one Penny, to two Pence the

Pound; their fattest and largest Poulets at Sixpence a piece; their Capons at eight-pence or Nine-pence a piece; their Geese at Ten pence or a Shilling; their Turkey-Hens at Fifteen or Eighteen pence; and their Turkey-Cocks at two Shillings or half a Crown. But Oysters, and Wild-Fowl are not so dear, as the things I have reckon'd before, being in their Season the cheapest Victuals they have. Their Deer are commonly sold for eight, ten, or twelve Shillings a Head, according to the scarcity.

The Bread in Gentlemen's Houses, is generally made of Wheat, but some rather choose the Pone, which is the Bread made of *Indian* Meal. Many of the poorer sort of People so little regard the *English* Grain, that though they might have it with the least trouble in the World, yet they don't mind to sow the Ground, because they won't be at the trouble of making a Fence particularly for it. And therefore their constant Bread is Pone, not so called from the Latine, *Panis*, but from the *Indian* Name *Oppone*.

A Kitchin-Garden don't thrive better or faster in any part of the Universe, than there. They have all the Culinary Plants that grow in *England*, and in far greater perfection, than in *England*: Besides these, they have several Roots, Herbs, Vine-fruits, and Salate-Flowers peculiar to themselves, most of which will neither increase, nor grow to Perfection in *England*. These they dish up various ways, and find them very delicious Sauce to their Meats, both Roast and Boild, Fresh and Salt; such are the Red-Buds, Sassafras-Flowers, Cymnells, Melons, and Potatoes. . . . I don't know any *English* Plant, Grain, or Fruit, that miscarries in *Virginia*; but most of them better their kinds very much, by being sowed or planted there. It was formerly said of the Red-top Turnip, that there in three or four years time, it degenerated into Rape; but that happen'd merely by an Error in saving the Seed; for now it appears, that if they cut off the top of such a Turnip, that has been kept out of the Ground all the Winter, and plant that top alone without the Body of the Root, it yields a Seed, which mends the Turnip in the next sowing.

Their Small-drink is either Wine and Water, Beer, Milk and Water, or Water alone. Their richer sort generally brew their Small-Beer with Malt, which they have from *England*, though they have as good Barley of their own, as any in the World; but for want of the convenience of Malt-Houses, the Inhabitants take no care to sow it. The poorer sort brew their Beer with Mollasses and Bran; with *Indian* Corn Malted by drying in a Stove; with Persimmons dried in Cakes, and baked; with Potatoes; with the green stalks of *Indian* Corn cut small, and bruised; with

Pompions; and with the *Batates Canadensis*, or *Jerusalem Artichoke*, which some People plant purposely for that use, but this is the least esteem'd of all the sorts before mention'd.

Their Strong Drink is *Madera Wine*, which is a Noble strong Wine; and Punch, made either of Rum from the *Caribbee* Islands, or Brandy distilled from their Apples, and Peaches; besides *French-Brandy*, Wine, and strong Beer, which they have constantly from *England*. (pp. 291-93)

. . . they are such abominable Ill-husbands, that tho' their Country be over-run with Wood, yet they have all their Wooden Ware from *England*; their Cabinets, Chairs, Tables, Stools, Chests, Boxes, Cart-Wheels, and all other things, even so much as their Bowls, and Birchen Brooms, to the Eternal Reproach of their Laziness. (p. 295)

And thus likewise have I seen several People, (especially New-Comers) so intemperate in devouring the pleasant Fruits, that they have fallen into dangerous Fluxes, and Surfeits. These, and such like Disorders, are the chief occasions of their Diseases. (p. 305)

The Gripes is the Distemper of the *Caribbee* Islands, not of that Country, and seldom gets footing there, and then only upon great Provocations; Namely, by the Intemperances before mentioned, together with an unreasonable use of filthy and unclean Drinks. Perhaps too it may come by new and unfine Cyder; Perry, or Peach-drink, which the People are impatient to Drink before they are ready; or by the excessive use of Lime-Juice, and foul Sugar in Punch and Flip; or else by the constant drinking of uncorrected Beer, made of such windy, unwholsom things, as some People make use of in Brewing. (pp. 306-07)

The Inhabitants are very Courteous to Travellers, who need no other Recommendation, but the being Human Creatures. A Stranger has no more to do, but they inquire upon the Road, where any Gentleman, or good House-keeper Lives, and there he may depend upon being received with Hospitality. This good Nature is so general smong their People, that the Gentry when they go abroad, order their Principal Servant to entertain all the Visitors, with every thing the Plantation affords. (pp. 312-13)

The extream fruitfulness of that Country, has been sufficiently shewn. . . . No Seed is Sowed there, but it

thrives, and most Plants are improved, by being Transplanted thither. And yet there's very little Improvement made among them, nor any thing us'd in Traffique, but Tobacco. . . . Apples from the Seed, never degenerate into Crabs, or Wildings there, but produce the same, or better Fruit than the Mother-Tree, (which is not so in *England*;) and are wonderfully improved by Grafting and Managing; yet there are very few Planters that graft at all, and much fewer that take any care to get choice Fruits.

The Fruit-Trees are wonderfully quick of growth, so that in six or seven years time from the Planting, a Man may bring an Orchard to bear in great plenty, from which he may make store of good Cyder, or distill great quantities of Brandy; for the Cyder is very strong, and yields abundance of in Spirit. Yet they have very few, that take any care at all for an Orchard; nay, many that have good Orchards, are no negligent of them, as to let them go to ruine, and expose the Trees to be torn, and barked by the Cattle.

Peaches, Nectarines, and Apricocks, as well as Plums and Cherries, grow there upon Standard Trees. They commonly bear in three years from the Stone, and thrive so exceedingly, that they seem to have no need of Grafting or Inoculating, if any Body would be so good a Husband; and truly I never heard of any that did Graft either Plum, Nectarine, Peach or Apricock in that Country.

Peaches and Nectarines I believe to be Spontaneous some-where or other on that Continent; for the *Indians* have, and ever had greater variety, and finer sorts of them than the *English*. The best sort of these cling to the Stone, and will not come off clear, which they call Plum-Nectarines, and Plum-Peaches, or Cling-Stones. Some of these are 12 or 13 Inches in the Girt. These sorts of Fruits are raised so easily there, that some good Husbands plant great Orchards of them, purposely for their Hogs; and others make a Drink of them, which they call Mobby, and either drink it as Cyder, or Distil it off for Brandy. This makes the best Spirit next to Grapes.

Grape-Vines of the *English* Stock, as well as those of their own Production, bear most abundantly, if they are suffered to run near the Ground, and increase very kindly by Slipping; yet very few have them at all in their Gardens, much less indeavour to improve them by cutting or laying. Indeed my Curiosity the last year, caused me to lay some of the white Muscadine, which came of a Stock removed thither from *England*, and they increased by this method to Admiration: I likewise set several Slips of the

cuttings of the same Vine, and the Major part of the Sets bore Grapes in perfection the first year, I remember I had seven full Bunches from one of them.

When a single Tree happens in clearing the Ground, to be left standing with a Vine upon it, open to the Sun and Air; that Vine generally produces as much as 4 or five others, that remain in the Woods. I have seen in this case, more Grapes upon one single Vine, than wou'd load a *London* Cart. And for all this, the People never remove any of them into their Gardens, but content themselves throughout the whole Country, with the Grapes they find thus wild; much less can they be expected to attempt the making of Wine or Brandy from the Grape.

The Almond, Pomgranate and Fig, ripen there very well, and yet there are not ten People in the Country, that have any of them in their Gardens, much less endeavour to preserve any of them for future spending, or to propagate them to make a Trade. . . . All sorts of Herbs have there a perfection in their flavour, beyond what I ever tasted in a more *Northern* Climate. And yet they han't many Gardens in the Country, fit to bear that name.

All sorts of *English* Grain thrive, and increase there, as well as in any other part of the World as for Example, Wheat, Barley, Oats, Rye, Peas, Rape, &c. And yet they don't make a Trade of any of them. Their Peas indeed, are troubled with Wivels, which eat a Hole in them. . . .

It is thought too much for the same Man, to make the Wheat, and grind it, bolt it, and bake it himself. And it is too great a charge for every Planter, who is willing to sow Barley, to build a Malt-House, and Brew-House too, or else to have no benefit of his Barley; nor will it answer, if he wou'd be at the Charge. These things can never be expected from a single Family: But if they had cohabitations, it might be thought worth attempting. Neither as they are now settled, can they find any certain Market for their other Grain, which if they had Towns, would be quite otherwise.

Rice has been tried there, and is found to grow as well, as in *Carolina*, or in any other part of the Earth: But it labours under the same inconvenience, the want of a Community, to husk and clean it; and after all, to take it off the Planters Hands. (pp. 314-17)

Bees thrive there abundantly, and will very easily yield to the careful Huswife, two Crops of Honey in a Year, and besides lay up a Winter-store sufficient to preserve their Stocks. (p. 317)

Hogs swarm like Vermine upon the Earth, and are often accounted such, insomuch that when an Inventory of any considerable Man's Estate is take by the Executors, the Hogs are left out, and not listed in the Appraisement. . . .

The Woods produce . . . Trees bearing Honey, and Sugar, as before was mention'd: Yet there's no use made of any of them, either for Profit or Refreshment. (p. 318)

What Advantages do they see the Neighbouring Plantations make of their Grain and Provisions, while they, who can produce them infinitely better, not only neglect the making a Trade thereof, but even a necessary Provision against an accidental Scarcity, contenting themselves with a supply of Food from hand to mouth, so that if it should please God, to send them an unseasonable Year, there wou'd not be found in the Country, Provision sufficient to support the People for three Months extraordinary. . . .

Thus they depend altogether upon the Liberality of Nature, without endeavouring to improve its Gifts, by Art or Industry. (p. 319)

[1709].

John Lawson. *A New Voyage to Carolina*. Ed. Hugh Talmage Lefler. Chapel Hill: Univ. of North Carolina Press, 1967.

We found [with the Indians] great Store of *Indian Peas*, (a very good Pulse) Beans, Oyl, Thinkapin Nuts, Corn, barbacu'd Peaches, and Peach-Bread; which Peaches being made into a Quiddony [a thick fruit syrup or jelly, originally made from quinces], and so made up into Loves like Barley-Cakes, these cut into thin Slices, and dissolv'd in Water, makes a very grateful Acid, and extraordinary beneficial in Fevers, as hath often been try'd and approv'd on by our *English* Practitioners. (p. 24)

By the Way, our Guide kill'd more Turkeys, and two Polcats, which he eat, esteeming them before fat Turkeys. Some of the Turkeys which we eat, whilst we stay'd there, I believe, weigh'd no less than 40 Pounds.

The Land we pass'd over this Day, was most of it good, and the worst passable. At Night we kill'd a Possum, being cloy'd with Turkeys, made a Dish of that, which tasted much between young Pork and Veal; their Fat being as white as any I ever saw.

. . . We cook'd our Supper, but having neither Bread, or Salt, our fat Turkeys began to be loathsome to us, altho' we were never wanting of a good Appetite, yet a Continuance of one Diet, made us weary. (pp. 33-34)

The *Indian Corn*, or *Maiz*, proves the most useful Grain in the World; and had it not been for the Fruitfulness of this Species, it would have proved very difficult to have settled some of the Plantations in *America*. It is very nourishing, whether in Bread, sodden, or otherwise; And those poor Christian Servants in *Virginia*, *Maryland*, and the other northerly Plantations, that have been forced to live wholly upon it, do manifestly prove, that it is the most nourishing Grain, for a Man to subsist on, without any other Victuals. And this Assertion is made good by the *Negro-Slaves*, who, in many Places, eat nothing but this *Indian Corn* and Salt. Pigs and Poultry fed with this Grain, eat the sweetest of all others. It refuses no Grounds, unless the barren Sands, and when planted in good Ground, will repay the Planter seven or eight hundred fold; besides the Stalks bruised and boiled, make very pleasant Beer, being sweet like the Sugar-Cane. (p. 81)

Buck-Wheat is of great Increase in *Carolina*; but we make no other use of it, than instead of Maiz, to feed Hogs and Poultry: And *Guinea Corn*, which thrives well here, serves for the same use.

Of the Pulse-kind, we have many sorts. The first is the Bushel-Bean, which is a spontaneous Product. . . . The Stalks they grow on, come to the Thickness of a Man's Thumb; and the Bean is white and mottled, with a purple Figure on each side it, like an Ear. They are very flat, and are eaten as the *Windsor-Bean* is, being an extraordinary well-relish'd Pulse, either by themselves, or with Meat.

We have the *Indian Rounceval*, or *Miraculous Pease*, so call'd from their long Pods, and great Increase. These are latter Pease, and require a pretty long Summer to ripen in. They are very good; and so are the *Bonavis*, *Calavancies*, *Nanticokes*, and abundance of other Pulse, too tedious here to name, which we found the *Indians* possess'd of, when first we settled in *America*; some of which sorts afford us two Crops in one Year; as the *Bonavis* and *Calavancies*, besides several others of that kind.

Now I am launch'd into a Discourse of the Pulse, I must acquaint you, that the *European* Bean planted here, will, in time, degenerate into a dwarfish sort, if not prevented by a yearly Supply of foreign Seed, and an extravagant rich Soil; yet these Pigmy-Beans are the sweetest of that kind I ever met withal.

As for all the sorts of *English* Pease that we have yet made tryal of, they thrive very well in *Carolina*. Particularly, the white and gray *Rouncival*, the common *Field-Pease*, and *Sickle-Pease* yield very well, and are of a good Relish. As for the other sorts, I have not seen any made tryal of as yet, but question not their coming to great Perfection with us.

The Kidney-Beans were here before the *English* came, being very plentiful in the *Indian* Corn-Fields.

The Garden-Roots that thrive well in *Carolina*, are Carrots, Leeks, Parsnips, Turneps, Potatoes, of several delicate sorts, Ground Artichokes, Radishes, Horse-Radish, Beet, both sorts, Onions, Shallot, Garlick, Cives [chives], and the Wild-Onions.

Of The Herbs of Carolina

The Sallads are the Lettice, Curl'd, Red, Cabbage, and Savoy. The Spinage round and prickly, Fennel, sweet and the common Sort, Samphire in the Marshes excellent, so is the Dock or Wild-Rhubarb, Rocket, Sorrel, *French* and *English*, Cresses of several Sorts, Purslain wild, and that of a larger Size which grows in the Gardens; for this Plant is never met withal in the *Indian* Plantations, and is, therefore, suppos'd to proceed from Cow-Dung, which Beast they keep not. Parsley two Sorts; Asparagus thrives to a Miracle, without hot Beds or dunging the Land, White-Cabbage from *European* or *New-England* Seed, for the People are negligent and unskilful, and don't take care to provide Seed of their own. The Colly-Flower we have not yet had an Opportunity to make Tryal of, nor has the Artichoke ever appear'd amongst us, that I can learn. Coleworts plain and curl'd, Savoys; besides the Water-Melons of several Sorts, very good, which should have gone amongst the Fruits. Of Musk-Melons we have very large and good, and several Sorts, as the Golden, Green, Guinea, and Orange. Cucumbers long, short, and prickly, all these from the Natural Ground, and great Increase, without any Helps of Dung or Reflection. Pompions yellow and very large, Burmillions, Cashaws [cushaws, crook neck squash], an excellent Fruit boil'd; Squashes, Simnals [simling], Horns, and Gourds; besides many other Species, of less Value, too tedious to name.

Our Pot-herbs and others of use, which we already possess, are Angelica wild and tame, Balm, Bugloss, Borage, Burnet, Clary, Marigold, Pot-Marjoram, and other Marjorams, Summer and Winter Savory, Columbines, Tansey, Wormwood, Nep [catnip], Mallows several Sorts, Drage [dredge, a spice] red and white, Lambs Quarters,

Thyme, Hyssop of a very large Growth, sweet Basil, Rosemary, Lavender: The more Physical, are *Carduus Benedictus*, the Scurvy-grass of *America*, I never here met any of the *European* sort; *Tobacco* of many sorts, Dill, Carawa, Cummin, Anise, Coriander, all sorts of Plantain of *England*, and two sorts spontaneous, good Vulneraries; Elecampane, Comfrey, Nettle, the Seed from *England*, none Native; Monks Rhubarb [species of dock, not garden rhubarb], Burdock, Asarum wild in the Woods, reckon'd one of the Snake-Roots; Poppies in the Garden, none wild yet discover'd; Wormseed, Feverfew, Rue, Ground-ivy spontaneous, but very small and scarce, *Aurea Virga*, four sorts of Snake-Roots, besides the common Species, which are great Antidotes againt that Serpent's Bite, and are easily rais'd in the Garden; Mint; *James-Town-Weed*, so called from *Virginia*, the Seed it bears is very like that of an Onion; it is excellent for curing Burns, and asswaging Inflammations, but taken inwardly brings on a sort of drunken Madness. One of our Marsh-Weeds, like a Dock, has the same Effect, and possesses the Party with Fear and Watchings. The Red-Root whose Leaf is like Spear-Mint, is good for Thrushes and sore Mouths; Camomil, but it must be kept in the Shade, otherwise it will not thrive; Housleek first from *England*; Vervin; Night-Shade, several kinds; Harts-Tongue; Yarrow abundance, Mullein the same, both of the Country; Sarsaparilla, and abundance more I could name, yet not the hundredth part of what remains, a Catalogue of which is a Work of many Years. . . . (pp. 82-84)

And as our Grain and Pulse thrives with us to admiration, no less do our Stocks of Cattle, Horses, Sheep, and Swine multiply.

The Beef of *Carolina* equalizes the best that our neighbouring Colonies afford; the Oxen are of a great size when they are suffer'd to live to a fit Age. I have seen fat and good Beef at all times of the Year, but *October* and the cool Months are the Seasons we kill our Beeves in, when we intend them for Salting or Exportation; for then they are in their prime of Flesh, all coming from Grass, we never using any other Food for our Cattle. . . .

The Veal is very good and white, so is the Milk very pleasant and rich, there being, at present, considerable Quantities of Butter and Cheese made, that is very good, not only serving our own Necessities, but we send out a great deal among our Neighbours.

. . . Mutton is (generally) exceeding Fat, and of a good Relish. . . .

The Pork exceeds any in *Europe*; the great Diversity and Goodness of the Acorns and Nuts which the Woods afford, making that Flesh of an excellent Taste, and produces great Quantities; so that *Carolina* (if not the chief) is not inferior, in this one Commodity, to any Colony in the hands of the *English*.

As for Goats, they have been found to thrive and increase well, but being mischievous to Orchards and other Trees, makes People decline keeping them.

Our Produce for Exportation to *Europe* and the Islands in *America*, are Beef, Pork, Tallow, Hides, Deer-Skins, Furs, Pitch, Tar, Wheat, *Indian-Corn*, Pease, Masts, Staves, Heading, Boards, and all sorts of Timber and Lumber for *Madera* and the *West-Indies*. . . . (pp. 87-88)

Many of the Women are very handy in Canoes, and will manage them with great Dexterity and Skill, which they become accustomed to in this watry Country. They are ready to help their Husbands in any servile Work, as Planting, when the Season of the Weather requires Expedition; Pride seldom banishing good Houswifry. The Girls are not bred up to the Wheel, and Sewing only; but the Dairy and Affairs of the House they are very well acquainted withal; so that you shall see them, whilst very young, manage their Business with a great deal of Conduct and Alacrity. . . . The marrying so young, carries a double Advantage with it, and that is, that the Parents see their Children provided for in Marriage, and the young married People are taught by their Parents, how to get their Living; for their Admonitions make great Impressions on their Children. (p. 91)

Beech is here frequent, and very large. . . . It affords a very sweet Nut, yet the Pork fed thereon (tho' sweet) is very oily, and ought to be harden'd with *Indian Corn*, before it is kill'd. (p. 101)

Hicory Nuts have very hard Shells, but excellent sweet Kernels, with which, in a plentiful Year, the old Hogs, that can crack them, fatten themselves, and make excellent Pork. These Nuts are gotten, in great Quantities, by the Savages, and laid up for Stores, of which they make several Dishes and Banquets. One of these I cannot forbear mentioning; it is this: They take these Nuts, and break them very small betwixt two Stones, till the Shells and Kernels are indifferent small; and this Powder you are presented withal in their Cabins, in little wooden Dishes; the Kernel dissolves in your Mouth, and the Shell is spit

out. This tastes as well as any Almond. Another Dish is the Soup which they make of these Nuts, beaten, and put into Venison-Broth, which dissolves the Nut, and thickens, whilst the Shell precipitates, and remains at the bottom. This Broth tastes very rich. . . .

Chinkapin is a sort of Chesnut, whose Nuts are most commonly very plentiful; insomuch that the Hogs get fat with them. They are rounder and smaller than a Chesnut, but much sweeter. (pp. 105-06)

Among the natural Fruits, the Vine first takes place, of which I find six sorts, very well known. The first is the black *Bunch-Grapes*, which yield a Crimson Juice. These grow common, and bear plentifully. They are of a good Relish, though not large, yet well knit in the Clusters. They have a thickish Skin, and large Stone, which makes them not yield much Juice. There is another sort of Black-Grapes like the former, in all respects, save that their Juice is of a light Flesh-Colour, inclining to a White. . . . Of those which we call *Fox-Grapes*, we have four sorts; two whereof are called Summer-Grapes, because ripe in *July*; the other two Winter-Fruit, because not ripe till *September* or *October*. . . . The black sort are frequent. . . . I have transplanted them into my Orchard, and find they thrive well, if manured: A Neighbour of mine has done the same; mine were by Slips, his from the Roots, which thrive to Admiration, and bear Fruit, tho' not so juicy as the *European* Grape, but of a glutinous Nature. However, it is pleasant enough to eat.

The other Winter Fox-Grapes, are much of the same Bigness. These refuse no Ground, swampy or dry, but grow plentifully on the Sand-Hills along the Sea-Coast, and elsewhere, and are great Bearers. I have seen near twelve Bushels upon one Vine of the black sort. Some of these, when thoroughly ripe, have a very pretty vinous Taste, and eat very well, yet are glutinous. The white sort are clear and transparent, and indifferent small Stones. Being removed by the Slip of Root, they thrive well in our Gardens, and make pleasant Shades.

Persimmon is a Tree, that agrees with all Lands and Soils. Their Fruit, when ripe, is nearest our Medlar; if eaten before, draws your Mouth up like a Purse, being the greatest Astringent I ever met withal. . . . There are two sorts of this Fruit; one ripe in Summer, the other when the Frost visits us.

We have three sorts of Mulberries, besides the different Bigness of some Trees Fruit. The first is the common red Mulberry, whose Fruit is the earliest we have, (except the Strawberries) and very sweet. . . . They are used

instead of Raisins and Currants, and make several pretty Kickshaws. They yield a transparent Crimson Liquor, which would make good Wine. . . . (pp. 108-09)

The Cherries of the Woods grow to be very large Trees. One sort, which is rarely found, is red, and not much unlike the Cornel-Berry. But the common Cherry grows high, and in Bunches, like *English* Currants, but much larger. They are of a bitterish sweet Relish, and are equally valuable with our small Black-Cherries, for an Infusion in Spirits. They yield a crimson Liquor, and are great Bearers.

Our Raspberries are of a purple Colour, and agreeable Relish, almost like the *English*; but I reckon them not quite so rich. . . .

The Hurts, Huckle-Berries, or Blues of this Country, are four sorts. . . . The *English* sometimes dry them in the Sun, and keep them to use in the Winter, instead of Currants. The *Indians* get many Bushels, and dry them on Mats, whereof they make Plum-Bread, and many other Eatables. They are good in tarts, or infused in Liquors. . . .

Our Dew-Berries are very good. But the Black-Berries are bitterish, and not so palatable, as in *England*.

The Sugar-Tree ought to have taken place before. It is found in no other parts of *Carolina* or *America*, that I ever learnt, but in Places that are near the Mountains. It's most like one sort of Maple, of any Tree, and may be rank'd amongst that kind. This Tree, which, I am told, is of a very tedious Growth, is found very plentifully towards the Heads of some of our Rivers. The *Indians* tap it, and make Gourds to receive the Liquor, which Operation is done at distinct and proper times, when it best yields its Juice, of which, when the *Indians* have gotten enough, they carry it home, and boil it to a just Consistence of Sugar, which grains of itself, and serves for the same Uses, as other Sugar does.

The *Papau* is not a large Tree. I think, I never saw one a foot through; but has the broadest Leaf of any Tree in the Woods, and bears an Apple about the Bigness of a Hen's Egg, yellow, soft, and as sweet, as any thing can well be. They make rare Puddings of this Fruit. The Apple contains a large Stone.

The wild Plums of *America* are of several sorts. . . . The most frequent is that which we call the common *Indian* Plum, of which there are two sorts, if not more. . . . Their Fruit is red, and very palatable to the sick. . . . The *English* large black Plum thrives well, as does the Cherry, being grated thereon. . . .

The *American* Damsons are both black and white, and about the Bignes of an *European* Damson. They grow any where, if planted from the Stone or Slip; bear a white Blossom, and are a good Fruit. They are found on the Sand-Banks all along the Coast of *America*. (pp. 109-11)

There is a very pretty, bushy Tree, about seven or eight Foot high, very spreading, which bears a Winter-Fruit, that is ripe in *October*. They call 'em Currants, but they are nearer a Hurt. I have eaten very pretty Tarts made thereof. They dry them instead of Currants. . . .

The *Bermudas* Currants grow in the Woods on a Bush, much like the *European* Currant. Some People eat them very much; but for my part, I can see nothing inviting in them, and reckon them a very indifferent Fruit. . . .

The Haw-thorn grows very plentifully in some parts of this Country. The Haws are quite different from those in *England*, being four times as big, and of a very pleasant agreeable Taste. . . .

The Black Haw grows on a slender Tree, about the Height of a Quince-Tree, or something higher, and bears the black Haw, which People eat, and the Birds covet also. (p. 112)

First, we will begin with Apples. . . .

The Golden Russet thrives well.

The Pearmains, of both sorts, are apt to speck, and rot on the Trees. . . .

Harvey-Apple; that which we call so, is esteem'd very good to make Cider of.

Winter Queening is a durable Apple, and makes good Cider.

Leather-Coat; both Apple and Tree stand well.

The Juniting is early ripe, and soon gone, in these warm Countries.

Codlin; no better, and fairer Fruit in the World; yet the Tree suffers the same Distemper, as the Pearmains, or rather worse; the Trees always dying before they come to their Growth.

The Redstreak thrives very well.

Long-stalk is a large Apple, with a long Stalk, and makes good Summer Cider.

We beat the first of our Codlin Cider, against reaping our Wheat, which is from the tenth of *June*, to the five and twentieth.

Lady-Finger, the long Apple, the same as in *England*, and full as good. We have innumerable sorts; some call'd Rope-Apples which are small Apples, hanging like Ropes of Onions; Flattings, Grigsons, Cheese-Apples, and a great

number of Names, given according to every ones Discretion.

The *Warden-Pear* here proves a good eating Pear; and is not so long ripening as in *England*.

Katharine excellent.

Sugar-Pear.

And several others without Name; The Bergamot we have not, nor either of the *Bonne Chrestiennes*, though I hear, they are all three in *Virginia*. Those sorts of Pears which we have, are as well relisht, as ever I eat any where; but that Fruit is of very short Continuance with us, for they are gone almost as soon as ripe.

I am not a Judge of the different sorts of Quinces, which they call *Brunswick*, *Portugal*, and *Barbary*; But as to the Fruit, in general, I believe no Place has fairer and better relisht. They are very pleasant eaten raw. Of this Fruit, they make a Wine, or Liquor, which they call Quince-Drink, and which I approve of beyond any Drink which that Country affords, though a great deal of Cider and some Perry is there made. The Quince-Drink most commonly purges those that first drink it, and cleanses the Body very well. The Argument of the Physicians, that they bind People, is hereby contradicted, unless we allow the Quinces to differ in the two Countries. The least Slip of this Tree stuck in the Ground, comes to bear in three years.

All Peaches, with us, are standing; neither have we any Wall-Fruit in *Carolina*; for we have Heat enough, and therefore do not require it. We have a great many sorts of this Fruit, which all thrive to Admiration, Peach-Trees coming to Perfection (with us) as easily as the Weeds. A Peach falling on the Ground, brings a Peach-Tree that shall bear in three years, or sometimes sooner. Eating Peaches in our Orchards makes them come up so thick from the Kernel, that we are forced to take a great deal of Care to weed them out; otherwise they make our Land a Wilderness of Peach-Trees. They generally bear so full, that they break great part of their Limbs down. We have likewise very fair Nectarines, especially the red, that clings to the Stone, the other yellow Fruit, that leaves the Stone; of the last, I have a Tree, that, most Years, brings me fifteen or twenty Bushels. I see no Foreign Fruit like this, for thriving in all sorts of Land, and bearing its Fruit to Admiration. I want to be satisfy'd about one sort of this Fruit, which the *Indians* claim as their own, and affirm, they had it growing amongst them, before any *Europeans* came to *America*. The Fruit I will describe, as exactly as I can. The Tree grows very large, most commonly as big as a Handsome Apple-tree;

the Flowers are of a reddish, murrey Colour; the Fruit is rather more downy, than the yellow Peach, and commonly very large and soft, being very full of Juice. They part freely from the Stone, and the Stone is much thicker than all the other Peach Stones we have, which seems to me, that it is a Spontaneous Fruit of *America*; yet in those Parts of *America* that we inhabit, I never could hear that any Peach-Trees were ever found growing in the Woods; neither have the foreign *Indians*, that live remote from the *English*, any other sort. And those living amongst us have a hundred of this sort for one other; they are a hardy Fruit, and are seldom damaged by the North-East Blasts, as others are. Of this sort we make Vinegar; wherefore we call them Vinegar-Peaches, and sometimes *Indian-Peaches*. (pp. 113-16)

Of Figs we have two sorts; One is the low Bush-Fig, which bears a large Fruit. . . .

The Tree-Fig is a lesser Fig, though very sweet. . . . This Tree thrives no where better, than on the Sand-Banks by the Sea.

. . . Our Cherries are ripe a Month sooner than in *Virginia*.

Gooseberries I have seen of the smaller sort, but find they do not do so well as in *England*, and to the Northward. (p. 116)

The Bears here are very common. . . . The Flesh of this Beast is very good, and nourishing, and not inferiour to the best Pork in Taste. It stands betwixt Beef and Pork, and the young Cubs are a Dish for the greatest *Epicure* living. I prefer their Flesh before any Beef, Veal, Pork, or Mutton; and they look as well as they eat, their fat being as white as Snow, and the sweetest of any Creature's in the World. If a Man drink a Quart thereof melted, it never will rise in his Stomach. We prefer it above all things, to fry Fish and other things in. Those that are Strangers to it, may judge otherwise; But I who have eaten a great deal of Bears Flesh in my Life-time (since my being an Inhabitant in *America*) do think it equalizes, if not excels, any Meat I ever eat in *Europe*. The Bacon made thereof is extraordinary Meat; but it must be well saved, otherwise it will rust. This Creature feeds upon all sorts of wild Fruits. When Herrings run, which is in *March*, the Flesh of such of those Bears as eat thereof, is nought, all that Season, and eats filthily. Neither is it good, when he feeds on Gum-berries, as I intimated before. (p. 121)

I have, for Necessity the the Wilderness, eaten [possum]. Their Flesh is very white, and well tasted; but their ugly Tails put me out of Conceit with that Fare. (pp. 125-26)

Crows are here less than in *England*. They are as good Meat as a Pigeon; and never feed on any Carrion. . . . The first sort is near as big as a Dove, and is very white and delicate Food. (p. 143)

The Pheasant of *Carolina* differs some small matter from the *English* Pheasant, being not so big, and having some difference in Feather; yet he is not any wise inferiour in Delicacy, but is as good Meat, or rather finer. (p. 144)

[The Woodcocks] are certainly as dainty Meat, as any in the World. (p. 144)

[The Partridges] are less than the *European* Bird, but far finer Meat. (p. 144)

[The Pigeons] were very fat, and as good Pigeons, as ever I eat. (p. 146)

[The Lark is] very fine Food. (p. 148)

[The flesh of Cranes] makes the best Broth, yet is very hard to digest. . . .

The Snow-Birds . . . are delicate Meat. (p. 150)

A Cygnet, that is, a last Year's Swan, is accounted a delicate Dish, as indeed it is. . . .

The sort of Swans call'd Hoopers, are the least. They abide more in the Salt-Water, and are equally valuable, for Food, with the former. . . .

The gray Brant, or Barnicle . . . eat well.

There is also a white Brant, very plentiful in *America*. . . . They are as good Meat as the other. . . .

The Sea-Pie, or gray Curlue, is about the Bigness of a very large Pigeon, but longer. . . . [He] is inferiour to no Fowl I ever eat of. . . .

The great gray Gulls are good Meat, and as large as a Pullet. They lay large Eggs, which are found in very great Quantities, on the Islands in our Sound, in the Months of *June*, and *July*. The young Squabs are very good Victuals, and often prove a Relief to Travellers by Water, that have spent their Provisions. (pp. 150-51)

The Water-Pheasant . . . are very good Meat.

The little Gray-Gull is . . . delicate Food. . . .

The black Duck is full as large as the other, and good Meat. (p. 152)

We have the same Teal, as in *England*, and another sort that frequents the Fresh-Water, and are always nodding their Heads. They are smaller than the common Teal, and dainty Meat. (p. 152)

I have seen about five hundred [wild turkeys] in a Flock; some of them are very large. I never weigh'd any myself, but have been inform'd of one that weigh'd near sixty Pound Weight. I have seen half a Turkey feed eight hungry Men two Meals. . . .

Fishermen are like a Duck, but have a narrow Bill, with Setts of Teeth. They live on very small Fish, which they catch as they swim along. They taste Fishy. The best way to order them, is, upon occasion, to pull out the Oil-Box from the Rump, and then bury them five or six Hours under Ground. Then they become tolerable.

Of Divers there are two sorts; the one pied, the other gray; both good Meat. . . .

[Bull-Necks] are a whitish Fowl, about the Bigness of a Brant; they come to us after *Christmas*, in very great Flocks, in all our Rivers. They are a very good Meat, but hard to kill, because hard to come near. They will dive and endure a great deal of Shot.

Red-Heads, a lesser Fowl than Bull-Necks, are very sweet Food, and plentiful in our Rivers and Creeks. (pp. 153-54)

We have a great pied Gull, black and white, which seems to have a black Hood on his Head; these lay very fair Eggs which are good; as are the young ones in the Season. . . .

The Sand-Birds are about the Bigness of a Lark, and frequent our Sand-Beaches; they are a dainty Food, if you will bestow Time and Ammunition to kill them. (p. 154)

Bottle-Noses are between the Crampois and Porpois, and lie near the Soundings. . . . The *French* esteem them good Food, and eat them both fresh and salt. (p. 158)

[Shark] Meat is eaten in scarce times; but I never could away with it, though a great Lover of Fish. . . .

The Dog-Fish are a small sort of the Shark Kind; and are caught with Hook and Line, fishing for Drums. They say, they are good Meat; but we have so many other sorts of delicate Fish, that I shall hardly ever make Tryal what they are. . . .

Cavallies . . . are as firm a Fish as ever I saw; therefore will keep sweet (in the hot Weather) two days, when others will stink in half a day, unless salted. They ought to be scaled as soon as taken; otherwise you must pull off the Skin and Scales, when boiled; the Skin being the choicest of the Fish. The Meat, which is white and large, is dress'd with this Fish.

Boneto's are a very palatable Fish, and near a Yard long. They haunt the Inlets and Water near the Ocean; and are killed with the Harpoon, and Fishgig.

The Blue Fish is one of our best Fishes, and always very fat. They are as long as a Salmon, and indeed, I think, full as good Meat. . . .

The Red Drum is a large Fish much bigger than the Blue-Fish. The Body of this is good firm Meat, but the Head is beyond all the Fish I ever met withal for an excellent Dish. We have greater Numbers of these Fish, than of any other sort. People go down and catch as many Barrels full as they please, with hook and Line, especially every young Flood, when they bite. These are salted up, and transported to other Colonies, that are bare of Provisions. (pp. 158-59)

Bass or Rock is both in Salt and Fresh-Water; when young, he much resembles a Grayling, but grows to the size of the large Cod-Fish. They are a very good firm Fish. Their Heads are souced, and make a noble Dish, if large.

Sheeps-Head has the general Vogue of being the choicest Fish in this Place. Indeed, it is a very delicate Fish, and well relish'd; yet I think, there are several others full as good as the Sheeps-Head. He is much of the Bigness of the Angel-Fish, and flat as he is; they sometimes weigh two or three Pound Weight. . . .

Plaice are here very large, and plentiful, being the same as in *England*.

Flounders should have gone amongst the Fresh-Water Fish, because they are caught there, in great Plenty.

Soles are a Fish we have but lately discover'd; they are as good, as in any other Part.

Mullets, the same as in *England*, and great Plenty in all Places where the Water is salt or brackish.

Shads are a sweet Fish, but very bony; they are very plentiful at some Seasons.

Fat-Backs are a small Fish, like Mullets, but the fattest ever known. They put nothing into the Pan, to fry these. They are excellent sweet Food.

The white Guard-Fish is shaped almost like a Pike, but slenderer. . . . When they dress him, they strip him,

taking off Scales and Skin together. His Meat is very white, and rather looks like Flesh than Fish. The *English* account them no good Fish; but the *Indians* do. The Gall of this Fish is green, and a violent Cathartick, if taken inwardly.

The green Guard is shaped, in all respects, like the other save that his Scales are very small and fine. He is indifferent good Meat; his Bones, when boil'd or fry'd, remain as green as Grass. The same sort of Fish come before the Mackarel in *England*.

Scate, or Stingray, the same as in *England*, and very common; but the great Plenty of other Fish makes these not regarded; for few or none eat them in *Carolina*, though they are almost at every ones Door. . . .

Lampreys are not common; I never saw but one, which was large, and caught by the *Indians*, in a Ware. They would not eat him, but gave him to me.

Eels are no where in the World better, or more plentiful, than in *Carolina*. (pp. 160-61)

Trouts of the Salt-Water are exactly shaped like the Trouts in *Europe*. . . . They are so tender, that if they are in or near fresh Water, and a sudden Frost come, they are benumm'd, and float on the Surface of the Water, as if dead; and then they take up Canoe-Loads of them. If you put them into warm Water, they presently recover.

The Crocus is a Fish, in Shape like a Pearch, and in Taste like a Whiting. They croke and make a Noise in your Hand, when taken with Hook or Net. They are very good.

The Herrings in *Carolina* are not so large as in *Europe*. They spawn there in *March* and *April*, running up the fresh Rivers and small fresh Runs of Water in great Shoals, where they are taken. They become red if salted; and, drest with Vinegar and Oil, resemble an Anchovy very much; for they are far beyond an *English* Herring, when pickled. (p. 161)

The Bones of [Sturgeon] make good Nutmeg-Graters. (p. 162)

Grindals are a long scaled Fish with small Eyes; and frequent Ponds, Lakes, and slow-running Creeks and Swamps. They are a soft sorry Fish, and good for nothing; though some eat them for good Fish.

These are a bright scaly Fish, which frequent the Swamps, and fresh Runs; they seem to be between an *English* Roach and a Bream, and eat much like the latter. The *Indians* kill abundance of these, and barbakue them,

till they are crisp, then transport them, in wooden Hurdles, to their Towns and Quarters. . . .

The white Fish are very large; some being two Foot and a half long and more. They are found a great way up in the Freshes of the Rivers; and are firm Meat, and an extraordinary well-relish'd Fish. (p. 163)

The smaller flat Crabs I look upon to be the sweetest of all the Species. They are the Breadth of a lusty Man's Hand, or rather larger. . . .

Oysters, great and small, are found almost in every Creek and Gut of Salt-Water, and are very good and well-relish'd. The large Oysters are excellent, pickled. . . .

Clams are a sort of Cockles, only differing in Shell, which is thicker and not streak'd, or ribb'd. These are found throughout all the Sound and Salt-Water-Ponds. The Meat is the same for Look and Taste as the Cockle. These make an excellent strong Broth and eat well, either roasted or pickled. (p. 164)

The Skellops, if well dress'd, are a pretty Shell-Fish; but to eat them only roasted, without any other Addition, in my Judgment, are too luscious.

Man of Noses are a Shell-Fish commonly found amongst us. They are valued for increasing Vigour in Men, and making barren Women fruitful; but I think they have no need of that Fish; for the Women in *Carolina* are fruitful enough without their Helps.

Wilks, or Periwinkles, are not so large here, as in the Islands of *Scilly*, and in other Parts of *Europe*, though very sweet.

The Sea-Snail-Horn is large, and very good Meat; they are exactly shaped as other Snail-Horns are. . . .

Spanish Oysters have a very thin Shell, and rough on the outside. They are very good Shell-Fish, and so large, that half a dozen are enow to satisfy an hungry Stomach. . . .

Finger-Fish are very plentiful in this Country; they are of the Length of a Man's Finger, and lie in the Bottom of the Water about one or two Foot deep. They are very good.

Shrimps are here very plentiful and good, and are to be taken with a Small-Bow-Net, in great Quantities. . . .

Muscles, which are eaten by the *Indians*, after five or six hours Boiling, to make them tender, and then are good for nothing.

Craw-Fish, in the Brooks, and small Rivers of Water, amongst the *Tuskeruro Indians*, and up higher, are found very plentifully, and as good as any in the World. (p. 165)

As to the *Indians* Food, it is of several sorts, which are as follows.

Venison, and Fawns in the Bags, cut out of the Doe's Belly; Fish of all sorts, the Lamprey-Eel excepted, and the Sturgeon our Salt-Water *Indians* will not touch; Bear and Bever; Panther; Pole-cat; Wild-cat; Possum, Raccoon; Hares, and Squirrels, roasted with their Guts in; Snakes, all *Indians* will not eat them, tho' some do; All wild Fruits that are palatable, some of which they dry and keep against Winter, as all sort of Fruits, and Peaches, which they dry, and make Quiddonies, and Cakes, that are very pleasant, and a little tartish; young Wasps, when they are white in the Combs, before they can fly, this is esteemed a Dainty; All sorts of Tortois and Terebins; Shell-Fish, and Sting-Ray, or Scate, dry'd; Gourds; Melons; Cucumbers; Squashes; Pulse of all sorts; *Rockahomine* Meal, which is their Maiz, parch'd and pounded into Powder; Fowl of all sorts, that are eatable; Ground-Nuts, or wild Potato's; Acorns and Acorn Oil; Wild-Bulls, Beef, Mutton, Pork, &c. from the *English*; *Indian* Corn, or Maiz, made into several sorts of Bread; Ears of Corn roasted in the Summer, or preserv'd against Winter.

The Victuals is common, throughout the whole Kindred Relations, and often to the whole Town; especially, when they are in Hunting-Quarters, then they all fare alike, whichsoever of them kills the Game. (pp. 182-84)

I have been often in their Hunting-Quarters, where a roasted or barbakued Turkey, eaten with Bears Fat, is held a good Dish; and indeed, I approve of it very well; for the Bears Grease is the sweetest and least offensive to the Stomach (as I said before) of any Fat of Animals I ever tasted. The Savage Men never beat their Corn to make Bread; but that is the Womens Work, especially the Girls, of whom you shall see four beating with long great Pestils in a narrow wooden Mortar; and every one keeps her Stroke so exactly, that 'tis worthy of Admiration. Their Cookery continues from Morning till Night. The Hunting makes them hungry; and the *Indians* are a People that always eat very often, not seldom getting up at Midnight, to eat. They plant a great many sorts of Pulse, Part of which they eat green in the Summer, keeping great Quantities for their Winter-Store, which they carry along with them into the Hunting-Quarters, and eat them.

The small read Pease is very common with them, and they eat a great deal of that and other sorts boil'd with their Meat, or eaten with Bears Fat, which Food makes them break Wind backwards, which the Men frequently do,

and laugh heartily at it, it being accounted no ill Manners amongst the *Indians*: Yet the Women are more modest, than to follow that ill Custom. (p. 216)

Those *Indians* that frequent the Salt-Waters, take abundance of Fish, some very large, and of several sorts, which to preserve, they first barbakue, then pull the Fish to Pieces, so dry it in the Sun, whereby it keeps for Transportation; as for Scate, Oysters, Cockles, and several sorts of Shell-fish, they open and dry them upon Hurdles, having a constant Fire under them. The Hurdles are made of Reeds or Canes in the shape of a Gridiron. Thus they dry several Bushels of these Fish, and keep them for their Necessities. (p. 218)

[1710-1719].

The Journal of John Fontaine: An Irish Huguenot Son in Spain and Virginia 1710-1719. Ed. Edward Porter Alexander. Williamsburg: Colonial Williamsburg Foundation, 1972.

[11 March 1714, on voyage to Virginia.] The Master of the ship informed me that the boats which they build for fishing Cod in Newfoundland are built like the wherries at Dublin . . . the boatmen only take the fish and bring it ashore to the splitters, headers, throat cutters, salters and barrow men. When they have time, they save the tongues, sounds and fat. Of the fat they make oil, and the tongues and sounds they salt up in casks. . . . The chief provisions to be carried there is pork, flour, butter and a good quantity of brandy, without which there is no living there. (pp. 68-69)

[13 November 1715.] After breakfast we went to see Mr. [Robert] Beverly's vineyard. We see the several sorts of vines which are natural and grow here in the woods. This vineyard is situated upon the side of a hill and consists of about three acres of land. He assures us that he made this year about four hundred gallons of wine. He hath been at great expences about this improvement. He hath also caves and a wine press, but according to the method they use in Spain he hath not the right method for it, nor his vineyard is not rightly managed. He hath several plants of French vines amongst them. (pp. 85-86)

[14 November 1715.] We . . . drunk very heartily of the wine of his own making, which was good, but I found by the taste that he did not understand how for to make it. This man lives well, but has nothing in or about his house but just what is necessary, tho' rich. He hath good beds

in his house but no curtains and instead of cane chairs he hath stools made of wood, and lives upon the product of his land. (p. 86)

[21 November 1715, at Germanna, a German settlement above the Falls of the Rappahannock River.] There is but nine families and they have nine houses built all in a line, and before every house about 20 feet from the house they have small sheds built for their hogs and hens, so that the hog stys and houses make a street. . . . The Germans live very miserably. . . . We got from the minister a bit of smoked beef and cabbage, which was very ordinary and dirtily drest. . . . [at Mr. Smith's house near the Falls] we had a good turkey for supper. . . . (p. 88)

[30 August 1716, at Beverley Camp on trip over the Blue Ridge.] We had . . . venison in abundance for ourselves which we roasted before the fire on wooden forks. . . . (p. 103)

[6 September 1716, at Spotswood Camp on trip over the Blue Ridge.] . . . we caught a dish of fish. We took some perch and a fish they call Chubb. The others went a hunting and killed deer and turkies. . . . We had a good dinner. After dinner we got the men all together and loaded all their arms and we drunk the King's health in Champagne, and fired a volley; the Prince's health in Burgundy, and fired a volley; and all the rest of the Royal Family in Claret, and a volley. We drunk the Governor's health and fired another volley. We had several sorts of liquors, namely Virginia Red Wine and White Wine, Irish Usquebaugh, Brandy, Shrub, two sorts of Rum, Champagne, Canary, Cherry punch, Cider, Water, &c. (p. 106)

Appendix C

GLOSSARY

Definitions for this glossary derive from Randle Holme's *Academy of Armory*, other primary documentary sources, and *The Oxford English Dictionary*. Two additional sources provided helpful information on ceramic typology and archaic food preparation equipment: *The Goods and Chattels of Our Forefathers*, ed. John S. Moore, Frampton Cotterell and District Historical Studies, 1 (London: Phillimore, 1976); Mary Beaudry, Janet Long, Henry Miller, Frazer Neiman, and Garry Stone, "A Vessel Typology for Early Chesapeake Ceramics: The Potomac Typological System," paper presented at the Jamestown Archaeological Conference, Jamestown Island, Virginia, 18 May 1979.

ALE. An alcoholic liquor made from fermented malt without hops.

ANDIRONS. Fireplace equipment consisting of horizontal iron bars supported at one end with an upright pillar and at the other end with a short foot, a pair used to support burning logs in a fireplace; sometimes defined as synonymous with fire dogs and sometimes having a rack to support a spit.

APPLE ROASTER. An iron utensil for roasting apples over an open fire; an earthen Dutch oven made from half a large pan, with

narrow shelf around internal curved wall and handles or knobs on back surface, used by placing food on shelf and positioning oven with open side facing fire.

BARBECUE. Indian cooking method in which food is broiled over an open fire, often on a hurdle.

BASIN. An open vessel with convex sides, brim or everted lip, and width greater than depth; used for dining, cooking, and washing.

BEER. an alcoholic liquor made from fermented malt (or other saccharine substance), flavored with hops. SMALL BEER. Beer with low alcoholic content.

BELL METAL. Alloy of copper and tin, with tin in larger proportion than in ordinary bronze.

BOLTING MILL. A bin, sieve, or cloth used for separating flour from bran.

BOTTLE. A bulbous vessel with narrow neck, with or without a handle, used for holding liquids; made of glass, earthenware, or stoneware.

BOWL. An open vessel with convex sides, usually of coarse earthenware and used most commonly in kitchen and dairy.

BREAD GRATER. A scraper.

BUTT. A cask for wine or beer, of capacity varying from 108 to 140 gallons, equal to two hogsheads.

BUTTERY. A room for storing food provisions.

CALICO. A fine cotton fabric.

CASE WITH BOTTLES. A box with hinged lid, containing square bottles.

CASTOR. A small utensil with perforated top, used to dust or sprinkle powders such as sugar and pepper.

CASK. A general term for a cylindrical wooden vessel, usually bulging in the middle and of greater length than breadth; generally used as a container of liquids.

CAUDLE. A warm drink of thin gruel mixed with wine or ale, sweetened and spiced, given chiefly to sick people.

CAUDLE CUP. A covered cup with two handles, for making and serving caudle; sometimes defined as synonymous with a posset cup.

CHAFING DISH. A brazier or vessel to hold burning coals, used for warming or cooking food.

CHEESE PAISE. A weight for weighing cheese.

CHEESE PRESS. An apparatus for pressing curds in cheese making, expelling moisture and whey.

CHEESE VAT (FATT). A wooden mold in which cheese curd was placed prior to being put in a cheese press.

CHOPPING KNIFE. An alternate name for a randing knife, a knife for cutting meat into strips.

CHINQUAPIN. A tree with a sweet edible nut resembling a small chestnut.

CHURN. A vessel for making butter by shaking and beating cream or milk to separate the fat from serous portions.

- CIDER. A beverage made from the juice of fruit expressed and fermented, most commonly made with apples.
- CLOCK. A clockwork mechanism for operating a jack.
- COLANDER (CULLANDER). A metal or earthen vessel, perforated with holes and used as a sieve or strainer.
- COOLER (COWL). A tub, generally wooden, used in baking, brewing, cheese-making, and salting meat; frequently a vessel in which foods or liquids were cooled or set aside to cool.
- COPPER. A large boiler or cooking vessel.
- COSTREL. A bottle with very narrow neck and two ears or strap handles; carried by travelers and workers.
- CUP. A small drinking vessel with handle, holding less than a pint.
- CWT. Abbreviation for hundredweight (originally 100 pounds).
- DAMASK. Silken fabric of wool, linen, or cotton; especially a linen fabric with pattern formed by contrasting satin and taffeta weaves.
- DELFTWARE. Tin-glazed earthenware, often with blue and white designs imitating Oriental porcelain.
- DIAPER. Twilled linen fabric usually woven with floral or geometric figures.
- DISH. A broad shallow vessel with flat bottom, concave sides, and nearly level rim; a generic term encompassing platter, dish, basin, trencher, plate, and saucer.
- DOGS, FIRE DOGS. Large andirons, frequently with spit racks.
- DOWLAS. Coarse linen fabric.

DRAM CUP. A cup for serving small portions of spirits or hot drinks.

DRINKING POT. A handled vessel for wine, beer, or other drink, used either as an individual drinking vessel or as a serving vessel, usually bulbous but sometimes cylindrical, with capacity ranging from one pint to more than two quarts.

DRIPPING PAN. A large shallow pan—rectangular, square, or oval—used to catch the drippings from meat roasting on a spit.

EARTHENWARE. Vessels and utensils made of low-fired clay which is slightly porous and usually covered with a nonporous glaze.

FIRKIN. A small cask for liquids, fish, or butter, originally containing a quarter of a barrel.

FLAGON. A vessel for serving beverages at table, sometimes with handle and spout, usually with a lid.

FLASKET. A small flask.

FLESH FORK. A large iron fork, usually two-tined, for removing meat from a pot.

FLOUR (FLOWER). The finer portion of meal which is separated by bolting.

FLOUR BOX. A tin box with perforated top for dredging meat or other foods with flour.

FRUMENTY (FURMENTY). A food made of hulled wheat boiled in milk and seasoned with sugar and spices.

FRYING PAN. A shallow pan, with long handle, in which food is fried.

FUNNEL. A cone-shaped vessel fitted with a short tube, used for pouring liquid or powder through a small opening.

GRATER. A kitchen utensil with a rasping surface; a scraper (as a bread grater).

GRIDIRON. Iron grid with short legs and a long handle, used for broiling flesh or fish over a fire.

GRUEL. A thin porridge made by boiling oatmeal or other cereal in milk or water.

HOGSHEAD. Measure of ale, beer, or cider containing 54 gallons; as a wine measure it contained 63 old wine-gallons or 52 1/2 imperial gallons.

HOLLAND. Coarse unbleached linen, or linen and cotton cloth sometimes glazed with oil and starch.

HOMINY. Indian corn hulled and ground more or less coarsely, prepared for food by boiling with water or milk; the coarser portion of pounded corn remaining after flour was removed by sifting.

HOPS. Ripened cones of the hop-plant, used to give a bitter flavor to malt liquors.

HORSE. Bench or plank on which implements or vessels, especially beer barrels, were placed.

HUNDREDWEIGHT. Avoirdupois weight equal to 112 pounds, originally 100 pounds; abbreviated cwt.

- HURDLE. A grill of wood, erected over an outdoor fire for cooking or drying food.
- JACK. A rotary contrivance to turn a spit, sometimes automated by a clock apparatus.
- JAR. A vessel of earthenware or stoneware, without spout or handle (or having two handles), usually more or less cylindrical in form.
- JUG. A handled vessel with bulbous body and with cylindrical neck rising from a pronounced shoulder; varying in size from individual drinking vessel to large serving vessel.
- LADLE. A large spoon with long handle and cup-shaped bowl.
- LATTEN. An alloy of copper and zinc, similar to brass.
- KETTLE. An open or covered cooking vessel, usually wider than tall, with a handle; used for boiling liquids or for brewing.
- MALT. Barley or other grain prepared for brewing or distilling by steeping, germinating (fermenting), and drying.
- MALT MILL. A mill for grinding or crushing malt.
- MAJOLICA. Tin-glazed earthenware, usually from Spain, Portugal, or Italy.
- MASLIN (MESSELINE, MASSLEDINE). Mixed grain, usually rye mixed with wheat; bread made of mixed grain.
- MORTAR. Vessel with cup-shaped cavity in which ingredients are pounded or pulverized by a pestle.
- MUG. A straight-sided drinking vessel with handle, taller than wide; varying in capacity from four ounces to more than two quarts.

MUSCOVADO. Raw or unrefined sugar, obtained from juice of sugar cane by evaporation and by draining off molasses.

MUSTARD POT. Pot or cruet for holding table mustard.

PAISE. A weight.

PAN. A broad, shallow, open vessel of metal or earthenware.

PATTY PAN. A small pan for cake or pastry.

PEEL. A baker's shovel, a stave of wood or iron with a paddle-shaped blade at the end, for placing dough in oven and removing baked loaves.

PEPPER BOX. A small box, usually round, with perforated top, used for sprinkling powdered pepper.

PERRY. Cider made with pears.

PESTLE. An instrument, usually club-shaped, for bruising or pounding substances in a mortar.

PEWTER. An alloy having tin as the principal component, usually an alloy of tin and lead for household utensils.

PIGGIN. A small wooden pail with an upright handle.

PIPE. A large cask for wine or other liquids, equaling half a tun, or two hogsheads, or four barrels; sometimes identified with a butt.

PITCHER. A handled vessel with a bulbous body and flaring neck.

PLATE. An eating vessel from seven to ten inches in diameter, either shallow or deep.

PORRIDGE. A food made by boiling cereal and water or milk to a thick consistency.

- PORRINGER (POTTINGER). A shallow vessel with one or two handles, used for porridge, soup, and pottage; made of metal, earthenware, or wood.
- POSNET. A small metal cooking pot with a handle and three short feet.
- POSSET. A drink of hot milk curdled with ale, wine, or other liquor, often flavored with sugar and spices, used as a delicacy or as a remedy for colds and other ailments.
- POSSET POT. A syllabub pot; a pot with a spout, two handles, and a cover, for drinking and serving posset and syllabub.
- POT. A cylindrical or other rounded vessel, deeper than broad, usually with three short feet.
- POT HANGER. A device for hanging a pot or kettle over a fire.
- POT HOOK. A hook suspended over a fire, for hanging a pot.
- POT RACK. A rack or bar with a series of holes or with a trammel, for hanging pots at various heights.
- POTTAGE. A thick soup or stew.
- POTTLE. A two-quart measure.
- POTTLE POT. A drinking vessel holding a pottle or two quarts.
- POWDERING TUB. A tub for salting or pickling meat, fish, or butter.
- PUDDING. A steamed or boiled mixture of flour or meal, fat, eggs, fruit, and spices; a sausage.

ROLLING PIN (ROWLING PIN). A heavy wooden cylinder used to thresh grain by rolling and pressing; a cylinder for rolling out dough or pastry.

RUNLET. A cask of varying capacity, for liquids.

SAFE. A ventilated chest or cupboard for protecting provisions from insects or vermin.

SALT, SALT CELLAR (SALT SELLER). A small vessel used at table for holding salt; sometimes a standing vessel with foot or pedestal, sometimes a shallow saucer-like vessel.

SALT BOX. A box for storing salt for domestic use.

SAUCE PAN. A small skillet with a long handle, for boiling or cooking small amounts of food.

SAUCER. A small shallow dish or deep plate for serving condiments at the table (a sauce-er).

SEETHE. To boil.

SGRAFFITO. "Scratched"; earthenware with a decoration scratched through a slip (surface glaze) to reveal a different colored ground.

SIEVE. A circular frame with finely meshed or perforated bottom, used to separate coarse from fine particles of a loose material.

SIFTER. A utensil for sifting; a sieve.

SKILLET. A cooking vessel with a long handle and three or four feet, or with no handle or feet but resting in a handled, footed frame; the ancestor of today's saucepan.

SKIMMER. A paddle-shaped utensil, usually perforated; with long handle, used for skimming liquids or for removing foods from liquid in a pot; with short handle, used for skimming cream from milk.

SKIMMING DISH. A shallow dish for skimming milk or for use in cheese making.

SLICE. A flat utensil, sometimes perforated, shaped like a skimmer but more oval; also called an egg spoon.

SODDEN. Cooked by boiling.

SPICE BOX. A box, usually having several compartments, for storing spices.

SPIT. A broach; a slender sharp-pointed rod for threading through meat to be roasted at a fire.

SPIT RACK. An iron bar, or set of bars, used to support a spit at a fire.

SPOONMEAT. A soft or liquid food eaten with a spoon.

STEW PAN. Similar to a sauce pan; a small pan with a long handle and a cover.

STILL. An apparatus for distillation; alternate name for a cooler.

STILLYARD. A frame or stand for a cask, used in brewing.

STRAINER. Utensil for straining or filtering, generally used for liquids.

SUGAR BOX. A small box, usually round, with perforated top, for sprinkling powdered sugar.

SYLLABUB (SILLIBUB). Posset, a drink of hot milk curdled with ale or wine, often flavored with sugar and spices.

SYLLABUB POT (SILLIBUB POTT). A posset pot; a pot with a spout, two handles, and a cover, for drinking and serving syllabub and posset.

TANKARD. A tall, one-handled drinking vessel, usually of pewter and sometimes with a lid.

TINKER'S DAM. A patch for a hole in a pan or kettle.

TOASTING FORK. A fork with a long handle, usually three-tined, for toasting bread or meat at a fire.

TRAY. An open shallow vessel.

TRENCHER. A wooden platter, originally a slice of bread used as a plate.

TRIVET. A tripod or three-footed stand; an iron grid to support a pan or other vessel placed over a fire or close to a fire for cooking or heating.

TUB. An open wooden vessel usually formed of staves and hoops, wider than tall, of cylindrical or slightly concave form, with a flat bottom.

TUCKAHOE. A marsh plant (arrow arum or golden club) having a rootstock used by Virginia Indians as food.

TUMBLER. A drinking cup without a handle or foot, originally having a rounded or pointed bottom so that it could not be set down until emptied.

TUN. A large cask or barrel, usually for liquids; sometimes used as a measure, equal to two pipes or four hogsheads.

WHITE MEAT. Dairy products: cheese, milk, whey, buttermilk.

VITA

Maryellen Spencer was born in Hampton, Virginia, on 18 March 1941. After earning a B. S. degree in Clothing, Textiles, and Related Art at Virginia Polytechnic Institute and State University in 1962, she was employed by Dudley-Anderson-Yutzy Public Relations Incorporated, New York: first as a test kitchen home economist and later as Director of Home Economics, with responsibilities in consumer affairs and product publicity, supervising creative recipe development and food photography. During a period of free-lance activity she wrote cookbooks and served as consultant to food companies, public relations agencies, photographers, and publishers.

As Lecturer in the College of Home Economics at Virginia Tech since 1977, she has taught in the General Home Economics curriculum, advised undergraduate students, and developed a gastronomy course. Long-term research projects developed during her doctoral program include a literary study of the American writer Henry Beston, a study of food in Western art, and studies of food in literature—especially the Victorian novel. In September 1982 she will begin an appointment at Virginia Tech as Assistant Professor of Human Nutrition and Foods and as Assistant Dean, College of Human Resources.

PUBLICATIONS

Books

The More or Less Cookbooks. 2 vols. Lock Haven, Penn.: Hammermill Paper Company, 1969. Rpt. New York: Van Nostrand Reinhold, 1976.

Articles

"Alphabet Soups." *U&Ic*, 3, No. 1 (1976), 14-17.

"Gastronomic Americana." *U&Ic*, 3, No. 3 (1976), 12-15.

"Can Mama Mac Get Them to Eat Spinach?" *Journal of American Culture*, 1 (1978), 403-411. Reprinted in *The World of Ronald McDonald*. Ed. Marshall Fishwick. Bowling Green, Ohio: Bowling Green Univ. Popular Press, 1978.

"Henry Beston (1888-1968): A Primary Checklist." Forthcoming in *Resources for American Literary Study*.

Joint Publication

Laura Jane Harper, Charles W. Bishop, and Maryellen Spencer. *Home Economics in Institutions Granting Bachelor's or Higher Degrees 1976-77*. Washington: American Home Economics Association, 1978.

Maryellen Spencer

FOOD IN SEVENTEENTH-CENTURY TIDEWATER VIRGINIA:

A METHOD FOR STUDYING HISTORICAL CUISINES

by

Maryellen Spencer

(ABSTRACT)

English settlers brought to seventeenth-century Virginia a sturdy yeoman cuisine based on bread, cheese, grains, fruits, vegetables, beer, and cider. In Virginia they added meat and seafood to that pattern and adopted Indian corn as their staple food. Emphasizing self-sufficiency in food production, Virginians concentrated food preparation activities on macro processes: dairying, salting meat, brewing, milling. As infrequent contrasts to frontier isolation, festive meals prompted revelry and display, not epicurean refinement.

This rudimentary cuisine reflected its social context as well as its English heritage. Most settlers emigrated as indentured servants, and the unbalanced sex ratio combined with high mortality to cause unstable household and family units. The scarcity of labor, absence of art and education, and isolation of plantations discouraged development of an innovative or complex cuisine. Seventeenth-century Virginians did not dine; they ate.

A method based on a comprehensive framework of research questions identifying components of a cuisine and of its historical context used a systematic procedure and three types of sources:

artifacts, documents, and iconographic records. Study of archaeological artifacts, probate inventories from county court records, and primary documentary accounts revealed the cuisine's physical possibilities: cooking and dining equipage, available foods. A dearth of research material on daily life and on women in seventeenth-century Virginia limited the findings on cooking and food processing methods, aesthetic standards, meal patterns and customs, and values relating to food.