

Immunomodulation of Flavonoid Biosynthesis  
in Transgenic *Arabidopsis thaliana*

Michael C. O. Santos

Dissertation submitted to the Faculty of the  
Virginia Polytechnic Institute and State University  
in partial fulfillment of the requirements for the degree of

DOCTOR OF PHILOSOPHY

in Biology

Approved by the Advisory Committee:

---

Brenda S. J. Winkel, Chairman

---

Eric. P. Beers

---

Charles L. Rutherford

---

Ann M. Stevens

---

Richard A. Walker

April 2001

Blacksburg, Virginia

## Abstract

A phage display antibody library was screened using the *Arabidopsis* flavonoid enzymes, chalcone synthase (CHS) or chalcone isomerase (CHI), as the target antigens. Three genes encoding anti-CHI antibodies in the single-chain variable fragment format (scFv) were isolated. Each anti-CHI gene was first subcloned into the vector, pRTL2, and then into the plant transformation vector, pBI121. At least 10 independently-transformed *Arabidopsis* plants were generated for each scFv gene through *Agrobacterium*-mediated transformation. The transgenic plants were subjected to segregation analysis until apparently homozygous populations were established in the T<sub>4</sub> generation. A wide variation in scFv expression levels was observed, ranging from undetectable to approximately 4% of total soluble protein. HPLC analysis was performed on methanolic extracts from seedlings of transgenic lines that had detectable levels of scFv expression. One line, B7b-1, which had low scFv expression despite carrying several copies of the transgene, was identified as having reduced amounts of flavonol glycosides. In addition, B7b-1 had a reduced capacity for anthocyanin accumulation, based on the appearance of five-day-old seedlings relative to wild type.

To verify that the scFv's were interacting directly with CHI in B7b-1, protein mobility shift assays were performed. In such assays, soluble proteins are extracted and subjected to electrophoresis under non-denaturing conditions to preserve their native conformation and associations with other proteins. In replicate immunoblots, the CHI from B7b-1 was shifted compared to the CHI from wild-type or line B7b-2, which expresses scFv's at a 20-fold higher level than B7b-1 but shows no phenotypic effect on flavonoid biosynthesis. In addition, in B7b-1 the scFv was seen to co-migrate with CHI, suggesting that the scFv's were indeed bound to CHI proteins. This co-migration was not observed in B7b-2. Quantitative immunoblot analyses using SDS-PAGE showed that

CHI protein levels in B7b-1 were unchanged relative to wild-type, indicating that the scFv did not affect the stability of this enzyme. Assays were also performed to determine if the scFv expressed in B7b-1 would have a direct effect on the catalytic activity of CHI. Three replicate activity assays revealed no consistent differences in  $K_M$  or  $V_{max}$  relative to wild-type. This suggests that the scFv might be associating with a structural region rather than the catalytic site of CHI. It is possible that such an association affects the ability of CHI to interact with the other enzymes of flavonoid biosynthesis *in planta*, resulting in lower pigment production.

Taken together, this project has demonstrated that scFv's selected from a phage display antibody library using recombinant antigens can be expressed *in planta* to bind a specific intracellular target antigen. The scFv-expression level in the transgenic plant, however, appears to be a critical factor in the production of functional antibodies that can successfully bind the target. It is possible that for each scFv there exists an optimal intracellular concentration range, necessitating the generation of many transgenic plants representing various levels of transgene expression. Finally, the successful alteration of flavonoid metabolism by the expression of an anti-CHI scFv illustrates the potential of the scFv-based immunomodulation approach as an alternative metabolic engineering strategy.

## **Dedication**

This work is dedicated to my family, especially my parents, Dr. Antonio and Evelyn Santos, who, after showing initial resistance to the idea of allowing me to go outside the Philippines to pursue my interest in science, became my best supporters. Their hilarious daily emails since the moment they got “wired” to the net in 1996 had always been better than caffeine. Dear parents, thank you for the constant assurance that the light at the end of the tunnel ... was not from an approaching train!

## **Acknowledgements**

I am very grateful to the members of my advisory committee, Dr. Beers, Dr. Rutherford, Dr. Stevens, and Dr. Walker for their contributions to the constructive discussions during the course of the project. I am especially grateful to Dr. Winkel, my major advisor, for considering me to work on this challenging feasibility study. Her unwavering optimism and implicit vote of confidence in my abilities as a research scientist had been very helpful in getting me past the difficult phases of the project.

I am also very thankful to Ben Crowley, Bryony Hasychak, and Karen Vaillant. Their diligence and attention to detail greatly facilitated the process of screening for transgenic plants, and the establishment of transgenic populations that were eventually analyzed in key assays. They have devoted many hours in performing their work with a passion that could only come from the desire to know the conclusion to a scientific puzzle. Thank you for taking to heart my daily “adopt-THIS-project” spiel!

Finally, I would like to thank the past and present members of the lab who have made my Winkel Lab-experience quite an interesting five-year journey. I will always remember Matt Pelletier, Ian Burbulis, and Dave Saslowsky for contributing immensely to the almost-comic tension of the weekly lab meetings; Chris Dana for always being a “sport” about my practical jokes (I honestly don’t know why he attracts pranks, naturally); Michelle Barthet and Daniel Owens for their friendship; and Ana Frazzon for her antics imported from Brazil. It had been a pleasure being a part of the Winkel Lab collage of scientists-in-training.

## Table of Contents

Chapter 1: Literature Review .....	1
Flavonoids .....	2
Flavonoid Biosynthesis .....	9
<i>Arabidopsis</i> as a Model System for Studying Flavonoid Biosynthesis .....	14
The Flavonoid Metabolon .....	15
The Phage Display Technique for Isolating Antibodies .....	18
Plant Genetic Engineering and the Application of Phage Display .....	27
References .....	32
Chapter 2: Immunomodulation of Flavonoid Biosynthesis in Transgenic <i>Arabidopsis</i> ...	58
Introduction .....	59
Materials and Methods .....	62
Phage Display Library Screening .....	62
Screening for Desirable Phage-secreting Colonies by ELISA .....	64
Plant Transformation Constructs .....	65
Plant Transformation .....	67
Growth of Seedlings for HPLC and Immunoblot Assays .....	69
HPLC Analysis of Flavonoid Content .....	70
Protein Extraction for Immunoblot Assays .....	70
Immunoblot Analysis of scFv and Flavonoid Enzyme Levels .....	71
DNA Isolation and Southern Blot Analysis .....	72

Naming System .....	73
Results .....	73
Discussion .....	79
References .....	82
Chapter 3: Conclusion .....	105
References .....	111
Appendices .....	114
A. Isolation of anti-CHS scFv's .....	115
Materials and Methods .....	116
Results and Discussion .....	116
References .....	119
B. Epitope Mapping .....	124
Materials and Methods .....	124
Results and Discussion .....	127
References .....	132
C. Segregation Analysis to Identify Homozygous Transgenic Plants .....	142
Results and Discussion .....	144
Reference .....	145
D. HPLC Analyses of UVB-exposed Seedlings .....	151
Materials and Methods .....	152
Results and Discussion .....	152

References .....	155
E. CHI Activity Assay .....	162
Materials and Methods .....	163
Results and Discussion .....	165
References .....	168

## List of Figures and Tables

### Chapter 1

Fig. 1: Flavonoid Biosynthetic Pathway .....	50
Fig. 2: Flavonoid C <sub>15</sub> structure .....	52
Fig. 3: Phage Display Panning Protocol .....	53
Fig. 4: scFv Library Construction .....	54
Fig. 5: Fab Library Construction .....	55
Fig. 6: Comparison of Phage Display with Immune System .....	56
Table 1: Cursory List of Published Work on the Isolation of Antibodies from Phage Display Antibody Libraries .....	57

### Chapter 2

Fig. 1: Constructs for Plant Transformation .....	88
Fig. 2: Immunoblots Using anti-CHI Phage-scFv's .....	90
Fig. 3: Sequence Alignment of anti-CHI scFv's .....	92
Fig. 4: Accumulation of scFv, CHS, and CHI in Transgenic Plants .....	94
Fig. 5: Analysis of Flavonoid Accumulation in Seedlings .....	96



Fig. 6: Differences in Anthocyanin Accumulation .....	98
Fig. 7: Determination of Transgene Copy Number .....	100
Fig. 8: Protein Mobility Shift Assay .....	102
Table 1: Level of scFv Expression in Transgenic Plants .....	104

## Appendices

A.	Fig. 1: Bar Graphs of ELISA Assay Results .....	120
	Fig. 2: Sequence Alignment of anti-CHS scFv's .....	122
B.	Fig. 3: Cloning Strategy for CHI Truncations .....	133
	Fig. 4: Expression of CHI Truncations in <i>E. coli</i> .....	135
	Fig. 5: Hydrophilicity and Antigenicity Indices .....	137
	Fig. 6: Immunoblot Analyses of CHI Truncations .....	139
	Table 1: Summary of Immunoassay Results .....	141
C.	Fig. 7: Segregation Analysis Strategy .....	146
	Table 2: Results of Segregation Analysis .....	148
D.	Fig. 8: HPLC Profiles of UV-B-exposed Seedlings .....	156
	Fig. 9: HPLC Profiles of UV-B-exposed Seedlings .....	158
	Fig. 10: HPLC Profiles of UV-B-exposed Seedlings .....	160
E.	Fig. 11: Assay for Spontaneous Conversion of Substrate .....	169
	Fig. 12: CHI Activity Assays .....	171
	Table 3: $K_M$ and $V_{max}$ Obtained from Activity Assays .....	173

<i>Curriculum vitae</i> .....	174
-------------------------------	-----

## Chapter 1

### Literature Review

## Flavonoids

Plants synthesize a remarkably diverse collection of chemicals. Quite notably, tremendous diversity is observed among “secondary” metabolites, a large group of compounds that until recently, had been regarded to be not completely paramount to plant survival. These are the compounds that have emerged through evolution as the bulk of the dynamic chemical vocabulary underlying plant-environment interaction. A recent estimate has put the total number of plant secondary metabolites at 100,000 compounds, with an additional 4,000 being discovered annually (Verpoorte et al. 1999). Of all these secondary metabolites, flavonoids have the distinction of being one of the best studied by far, due to the easily-identifiable phenotypic manifestations of these compounds in plants (Fig. 1). A well-known role of flavonoids is in fruit and flower coloration. In fact, flavonoid pigments contributed to Gregor Mendel’s insights on heredity and trait segregation when he serendipitously utilized color variants of peas in his seminal cross-pollination experiments. These pigments also contributed to Barbara McClintock’s discovery of the phenomenon of DNA transposition in which the movement of transposable elements resulting from specific maize crosses corresponded with particular anthocyanin pigmentation patterns.

Among flower-bearing plants, coloration patterns are thought to aid insects or birds in locating target fruits or flowers. The responding animals, in turn, become unwitting agents of seed-dispersal or pollination in the process of consecutive visits to multiple plants. Field evidence for such a role in insect-plant symbiosis has been established in experiments using *Delphinium nelsonii*. In these experiments, Waser and Price (1983) observed that there was a clear inverse relationship between removal of colored petals

and the number of insect visits to the flower. This had a concomitant impact on the percentage of pollination among flowers under the different treatments, with flowers with the least number of petals having the lowest pollination rate.

Ultraviolet light (UV) is a highly potent inducer of oxidative damage. It is classified into three wavelength ranges, namely UVA (320-390 nm), UVB (280-320 nm), and UVC (<280 nm). In plants, the effect of UVB is especially pronounced in the chloroplast where an unusually high level of reactive molecules such as oxygen radicals and peroxides accumulate upon irradiance (Chow et al. 1992). Furthermore, prolonged UV exposure can damage cellular components, including DNA molecules, which consequently accumulate deleterious amounts of cyclobutane pyrimidine dimers (CPD) and pyrimidine(6,4)pyrimidone dimers as photoproducts (Cadet et al. 1992; Mitchell and Nairns 1989). Because flavonoids, together with other phenolics such as sinapate esters, are UVB-absorbent, and because they are strategically produced in the upper epidermal cells of leaves (Caldwell et al. 1983; Day et al. 1993), these compounds have been implicated as a major class of protectants against UV-induced damage. Several experiments collectively support this hypothesis. For one, upon exposure to high UVB irradiance, *Arabidopsis* has been observed to specifically accumulate flavonoids (Jordan et al. 1994; Schnitzler et al. 1996), consistent with the increased transcript levels of genes necessary for their biosynthesis (Jordan et al. 1998; Kubasek et al. 1998). In addition, experiments using mutants that are defective in flavonoid biosynthesis have shown that complete absence or drastic reduction of these compounds in *Arabidopsis* results in hypersensitivity to UVB (Li et al. 1993). However, a compensatory increase in a related class of pigments, sinapate esters, can diminish the hypersensitive phenotype (Landry et

al. 1995). Further evidence of the role of flavonoids in protection of DNA from UV has come from studies using maize (Stapleton and Walbot 1994). In these experiments, DNA damage, analyzed by measuring levels of CPD formation, was significantly higher in plants from a flavonoid-deficient line than from plants that produced flavonoids. Furthermore, *in vitro* run-off transcription assays performed using DNA pre-treated with UVB showed that co-incubation with flavonoids prevented transcription stalling that normally results from CPD formation (Kootstra 1994). Such protective characteristics, in addition to the well-known free-radical scavenging capability (Rice-Evans et al. 1995), lends support to the role of flavonoids as plant sunscreens that attenuate the deleterious effects of irradiation.

Flavonoids have also been implicated in plant fertility. In petunia, disruption of flavonoid biosynthesis by expressing an anti-sense mRNA for the gene that encodes chalcone synthase (CHS), the first enzyme of the flavonoid pathway (Fig. 1), was shown to result in male sterility (van der Meer et al. 1992). Later biochemical complementation studies using an inbred line of petunia with a CHS gene mutation confirmed this early finding (Napoli et al. 1999). This mutant, designated “wha” for its white anthers, was male sterile, as its pollen was unable to germinate *in vitro*. Nanomolar addition of a flavonol compound, kaempferol, however, rescued the pollen. In a related experiment, a radioactive feeding assay demonstrated that the pollen rescue was mediated by flavonols, as the radioactivity coming from glycosylated forms of <sup>14</sup>C-labeled kaempferide (a flavonol with a 4' methoxyl group) was recovered from HPLC extracts of germinated pollen from male-sterile plants (Xu et al. 1997). Thus, at least in petunia, flavonoids are required for pollen viability. In maize, there is an increase in transcript levels for the

gene encoding flavanone-3-hydroxylase (F3H) during microsporogenesis in the anthers, an observation consistent with a requirement of flavonols for functional maize pollen because F3H is directly involved in the synthesis of these compounds (Fig. 1) (Deboo et al. 1995). It is interesting to note, however, that flavonols, which are seen to accumulate in the reproductive organs of a number of species, are not universally required for male fertility. In potatoes, pollen germination can proceed without a concomitant increase in flavonols (van Eldik et al. 1997). Furthermore, *Arabidopsis* mutants that are completely defective in flavonoid production have been shown to produce fertile pollen (Burbulis et al. 1996).

Flavonoids may also have a role in regulating transport of the plant hormone, auxin. The process of auxin transport involves phytoalexins (compounds capable of inhibiting gravitropic and phototropic responses as well as polar auxin transport) and corresponding receptors located on the plasma membrane (Rubery 1990). Phytoalexin-receptor interaction is thought to result in the inhibition of an auxin efflux carrier. Certain flavonoid compounds such as quercetin, apigenin, and genistein appear to be capable of regulating auxin transport by inhibiting phytoalexin-receptor interaction. In addition, these flavonoids demonstrate phytoalexin-like effects such as the capability to block auxin efflux. In a recent work by Murphy et al. (2000), *in vivo* evidence for the role of flavonoids in auxin transport was obtained by performing feeding assays using radiolabeled auxin,  $^{14}\text{C}$ -IAA (indole-3-acetic acid), with the *Arabidopsis* mutant, *tt4*, which does not synthesize flavonoids as it is defective for CHS. Whereas untreated *tt4* plants did not retain  $^{14}\text{C}$ -IAA in root tissues, *tt4* plants treated with naringenin, a flavonol precursor, showed a normal  $^{14}\text{C}$ -IAA distribution and accumulation in roots. Together

with findings that show co-localization of flavonoids with aminopeptidases associated with the synthesis of phytoalexin-inhibiting compounds, these results implicate endogenous flavonoids in the regulation of auxin transport.

Another role of flavonoids is in the induction of nodulation genes necessary for the establishment of nitrogen-fixing bacterial symbionts belonging to the genera *Rhizobium*, *Bradyrhizobium*, and *Azorhizobium*, in root nodules of legumes. Several experiments have identified various flavonoid molecules as the major compounds in root exudates responsible for *nod* gene induction (Peters et al. 1986; Zaat et al. 1987; Zaat et al. 1989) (Fig. 1). Release of flavonoids into the soil is thought to trigger a chain of events beginning with the flavonoid-dependent induction of specific bacterial nodulation genes (i.e. *NodD*). A coordinated execution of plant and microbial genetic programs takes place, ultimately resulting in the establishment of the bacteria in root nodules of the compatible host legume (Fisher and Long 1992; Schlaman et al. 1992). Consistent with a role for flavonoids in establishing this symbiotic relationship is the finding that CHS transcript levels in pea are elevated in zones where root hairs emerge (Yang et al. 1992). This is similarly observed in alfalfa (McKhann and Hirsch 1994), though interestingly, not all the transcripts for downstream enzymes such as F3H and dihydroflavonol reductase (DFR) exhibit the same distribution pattern (Charrier et al. 1995). Moreover, not all flavonoids promote nodulation. In fact, some flavonoids that induce *nod* gene expression in one microbial species can be inhibitory in another (Peters and Long 1988). The spectrum of flavonoid compounds in the root exudate of a particular plant is therefore thought to be a significant determinant of host-microbe compatibility (van Rhijn and Vanderleyden 1995).

Flavonoids are also implicated in plant defense against pathogens. One of the major responses of plants when exposed to a range of pathogenic fungi or bacteria is the production of phytoalexins. These are defense-related compounds that include isoflavonoids (Fig. 1), among other low molecular weight chemicals synthesized after pathogen exposure. Legumes, in particular, are widely known to accumulate elevated amounts of these compounds during the defense response against fungal pathogens. For instance, early experiments with *Phaseolus vulgaris* showed upregulation of CHS mRNA with a concomitant accumulation of phytoalexins in tissues adjacent to sites of fungal infection (Bell et al. 1986). A similar response was observed upon wounding, though an attempt at a more detailed analysis revealed that different CHS genes were induced by fungal elicitation and by wounding. This suggests that with diverse environmental stresses comes a correspondingly diverse regimen of regulatory responses (Ryder et al. 1987). Isoflavonoids have also been shown to be deterrents of nematode invasion of alfalfa roots. HPLC analysis of isoflavonoid metabolites from roots of cultivars that are either susceptible or resistant to root-lesion nematodes has shown that the relative proportions of each isoflavonoid were different, with medicarpin being highest in roots of resistant plants (Baldrige et al. 1998). Interestingly, the overall levels of isoflavonoids were the same for both resistant and susceptible alfalfa even after nematode elicitation. In this case, resistance was more dependent on the isoflavonoid composition than their total amounts.

Currently, there is great interest in increasing the production of medicarpin by augmenting the pool of isoflavone intermediates in transgenic plants. Specifically, attempts have been made to clone and overexpress isoflavone *O*-methyltransferase, a



P450 enzyme that methylates the 4' position of the isoflavone B-ring (Dixon and Steele 1999). Although the enzyme methylates isoflavones at the 7-position of the A-ring *in vitro*, it actually performs the correct methylation in transgenic alfalfa upon fungal elicitation, resulting in increased levels of the compound, formononetin, the substrate processed through a series of catalytic steps in the isoflavonoid branch pathway to form medicarpin (Fig. 1). Subsequent increase in medicarpin resulted in reduced susceptibility of the transgenic plant to fungal leaf spot pathogen.

Other products of the isoflavonoid branch pathway that have gained much attention are steroid-like compounds that are being extensively studied for therapeutic potential. Daidzein and genistein, in particular, have been implicated as the major soy components that reduce cancer incidence in societies in which the diet includes high levels of soy products (Denis et al. 1999; Griffiths et al. 1999). Presumably due to structural similarity to the animal steroid, estrogen, these compounds have demonstrable estrogenic and anti-estrogenic activities, at least *in vitro* and in mice systems (Breinholt et al. 2000; Zand et al. 2000). In mice, these compounds undergo further elaboration (additional hydroxylation or dehydrogenation), which result in varying levels of estrogenic potency when tested *in vitro*. Such modifications are thought to affect the efficacy of isoflavonoids in inhibiting steroid-metabolizing enzymes such as aromatase, 5- $\alpha$ -reductase, and 17- $\beta$ -hydroxysteroid reductase, which are crucial to the progression of steroid-dependent carcinomas. In addition to these hormonal effects, genistein, together with the flavonols, myricetin and quercetin, have been shown to interact with topoisomerase II (Constantinou et al. 1995). Whereas genistein inhibited the activity of topoisomerase by inducing topo II-mediated DNA cleavage, quercetin stabilized the topo

II-DNA cleavage complex, indicating that both flavonoid molecules have potential as anti-proliferation agents in tumors. Considering the beneficial agronomic and human health implications of these specific isoflavonoids and flavonols, the branch pathways leading to their syntheses appear to be ideal targets for metabolic engineering efforts.

### Flavonoid Biosynthesis

Flavonoids have a basic C<sub>15</sub> structure consisting of two benzene rings, termed A and B, linked together by a three-carbon chain (Fig. 2). A third ring, C, formed by the closure of the chain, is present in most flavonoids. The oxidation state of this third ring is generally the basis upon which these compounds are classified (Stafford 1990).

Compounds within each major group are distinguished primarily by the number and orientation of substitutions (i.e. hydroxyl and methoxyl) in rings A and B. The substitution patterns in these rings are limited and can be summarized as follows: the A-ring is generally hydroxylated at the C<sub>5</sub> and C<sub>7</sub>, or at the C<sub>7</sub> position alone; the B-ring is generally hydroxylated at the C<sub>4'</sub> position, paralogous to the point of attachment of the three-carbon chain, and is rarely methylated; either or both carbon positions orthologous to the C<sub>4'</sub> position of the B-ring can be hydroxylated or methylated. In nature, these compounds are stabilized by glycosylation, in which one or more hydroxyl groups are each linked to a mono, di, or trisaccharide. Such modification is thought to protect the compounds from rapid oxidation, as it has long been demonstrated, for example, that flavonols such as quercetin and myricetin glycosides are stable, in contrast to the non-glycosidated forms that are susceptible to phenolase-mediated oxidation (Roberts 1960). In addition, such sugar conjugation increases solubility, as flavonoids are generally

insoluble in plant sap when present as aglycones (not conjugated to sugars) (Swain 1976; Koes et al. 1994).

Light absorption in the visible region of the spectrum (i.e. 400 to 800 nm) causes compounds to appear colored. Among flavonoids, the colored subset of compounds is the result of hyperchromic shifts in absorbance from that of simple phenols, which have an absorbance maximum of 280 nm, to the visible range of the light spectrum. Such shifts occur due to electronic conjugation (the phenomenon in which non-bonded electrons are delocalized along a stretch of hydrocarbon skeleton) between the carbonyl group at C<sub>4</sub> of the three-carbon chain and the hydroxyl groups of the two benzene rings flanking the chain. Generally, the larger the extent of conjugation, the longer the absorption wavelength of the compound. This phenomenon occurs because the level of unsaturation in any given molecule, or in this case, the degree of conjugation in flavonoids, facilitates the electronic transition to a higher energy state. Due to variations in length of conjugation and in chemical modifications that alter absorbance (i.e. increased hydroxyl substitution generally increases absorption wavelength, whereas the opposite effect is observed with increased glycosylation), the palette of pigments available to flavonoid-synthesizing organisms is quite extensive. Among flower-bearing plants, this is comprised of the red, blue or purple-colored anthocyanins, yellow chalcones and aurones (true flavonoids), and colorless compounds such as flavonols and flavanones that can shift flower color by complexing with anthocyanins and metal ions, a phenomenon referred to as co-pigmentation (Swain 1976; Koes et al. 1994).

Though flavonoids are well known as major flower pigments, these compounds occur in all parts of the plant. In fact, even mosses and ferns, which are outside the category of

higher plants, produce several of the major classes of flavonoids (Hahlbrock 1981). In all plants, the precursors of the first flavonoid molecule, naringenin chalcone (a basic C<sub>15</sub> structure with an open C-ring), are derived from the general phenylpropanoid pathway, which provides 4-coumaroyl-CoA, and fatty acid biosynthesis, which results in the acetyl-CoA carboxylase-mediated formation of malonyl-CoA (Fig. 1). Naringenin chalcone is synthesized by the first enzyme of flavonoid biosynthesis, CHS, which catalyzes the condensation of three molecules of malonyl-CoA with one molecule of 4-coumaroyl-CoA. Early tracer experiments showed that the A-ring is formed from the three malonyl-CoA precursors, while the B-ring is derived from 4-coumaroyl-CoA (Hahlbrock 1981). The resulting intermediate, naringenin chalcone, is rapidly isomerized by the next enzyme, chalcone isomerase (CHI), which catalyzes the closure of the three-carbon chain to form the C-ring. Modifications by specific suites of downstream enzymes result in the production of a variety of end products. Interestingly, even with a restricted substitution pattern, a huge assortment of flavonoid pigments can be synthesized when additional terminal modifications such as the addition of sugars are considered as described above. To date, more than 6400 flavonoid compounds have been identified (Harborne and Williams 2000).

Much of the initial work leading to the elucidation of the flavonoid pathway was done using suspension cultures of parsley. Characterization of flavonoid biosynthesis at the genetic level, however, has been significantly advanced using *Arabidopsis*, maize, snapdragon, and petunia. Early experiments on parsley cell cultures showed that flavonoid accumulation could be induced by UV exposure (Wellman 1975). Subsequent work further revealed that flavonoid accumulation was preceded by a transient increase in

CHS transcript levels upon UV treatment (Schmelzer et al. 1988). Research involving other plant species, however, showed that induction could also be mediated by other factors including blue light (Christie and Jenkins 1996; Fuglevand et al. 1996; Hahlbrock and Scheel 1989; Shirley et al. 1992), white light (Toguri et al. 1993), wounding (Arimura et al. 2000; Richard et al. 2000), fungal elicitation (Ebel et al. 1984; Glassgen et al. 1998), and even non-endogenous signal molecules such as airborne methyl jasmonate (Richard et al. 2000). Extensive work had been done to elucidate the regulatory mechanisms controlling flavonoid biosynthesis in several species. To this end, regulatory genes from maize, snapdragon, petunia, and *Arabidopsis* have been cloned (reviewed in Winkel-Shirley 2001). Some of these were subsequently used to complement specific regulatory mutants. Such experiments have provided valuable insights on regulatory proteins governing the expression of flavonoid structural genes. For instance, in maize, a line with non-pigmented kernels due to a mutation in the gene encoding a helix-loop-helix-type transcription factor, *R*, could be functionally restored by constitutively expressing either one of two *R* homologues, *Lc* or *B*, which are both normally expressed only in maize leaves (Dooner et al. 1991; Ludwig and Wessler 1990). This suggests that the three transcription factors are functionally similar. Tissue-specific expression of these regulators, however, defines the regions for regulatory activity. Complementation experiments have also been performed between different species. Specifically, *Lc* has been shown to restore anthocyanin biosynthesis in *Arabidopsis* and petunia carrying the flavonoid regulatory mutations, *ttg* and *an2*, respectively (Quattrocchio et al. 1993). In most maize tissues, the *R* family of regulatory proteins, together with the C1 myb-domain-containing transcription factors, control genes encoding enzymes for the entire

pathway from CHS to the final glucosyl transferase in the synthesis of the flavonoid end-product, anthocyanin glucoside (Taylor and Briggs 1990). Interestingly, in other plant species, the regulatory homologues of the maize flavonoid transcription factors do not exhibit the same breadth of control. For instance, in snapdragon, the *delila* regulatory gene, homologous to the R family genes of maize, does not control the expression of CHS and CHI, but does control the expression of F3H and downstream enzymes required for anthocyanin biosynthesis (Martin and Gerats 1993). In petunia, control by the *an* series of regulatory genes (*an1*, *2*, *4*, and *11*) occurs from DFR onwards (Spelt et al. 2000).

The activity of a flavonoid transcription factor in one plant species can be somewhat different from that of a homologue in another. For instance, TTG1 of *Arabidopsis* is related to AN1 of petunia in that both contain WD40 repeats and regulate proanthocyanidin and anthocyanin biosynthesis. However, TTG1 is also required for trichome development whereas AN1 is not (Walker et al. 1999). This overlap of regulatory control in two very distinct developmental programs by one transcription factor is unusual, and in fact, has been observed in only one other species, *Matthiola incana*, a close relative of *Arabidopsis* (reviewed in Winkel-Shirley 2001). Such discrepancy in regulatory effects is further demonstrated in complementation and heterologous expression experiments. Whereas the maize R protein can complement *r* mutants, putative petunia and snapdragon orthologs (i.e. AN1 and DEL) that contain the same basic helix-loop-helix motif found in R failed to do so (Mooney et al. 1995; Quattrocchio et al. 1998). Furthermore, whereas heterologous expression of DEL in

tobacco and tomato resulted in intensification of anthocyanin pigmentation, DEL expression in *Arabidopsis* did not have a strong phenotypic effect (Mooney et al. 1995).

The redundancy of function of transcription factors within the same tissue has been studied for at least two myb-domain-containing regulatory proteins, MYB305 and MYB340, which both activate the expression of flavonoid structural genes in snapdragon (Moyano et al. 1996). The two regulatory proteins differed in strength in activating common target genes *in vitro*. However, the ability of the stronger activator, MYB340, to bind target promoters appeared to be negatively affected by phosphorylation. This suggests that the weaker transcription factor can act as an effective attenuator of MYB340 activity by outcompeting MYB340 for binding of common target promoters. Taken together, these results indicate that transcriptional regulation is a major level of control and that differences between species could be primarily in the *cis* elements that ultimately affect the level of expression and accumulation pattern of each enzyme.

#### *Arabidopsis* as a Model System for Studying Flavonoid Biosynthesis

*Arabidopsis* is particularly useful in characterization of the flavonoid biosynthetic pathway due to the relative simplicity of the genetic blueprint for the pathway's enzymes. With the exception of flavonol synthase, all the major enzymes appear to be encoded by single-copy genes (reviewed in Winkel-Shirley 2001). In addition, a collection of lines carrying mutations affecting specific steps in the biosynthetic pathway is available. These mutants are named “*tt*” for “*transparent testa*” in reference to the altered seed coat color that is the major visible phenotype. Numerous recent experiments that utilized *tt* mutants have improved the understanding of flavonoid biosynthesis. A significant

finding came from work that correlated the coordinate or differential expression of flavonoid genes at the transcript level with the abundance of the corresponding enzymes and the resulting effects on the flavonoid spectrum (Cain et al. 1997; Shirley et al. 1995; Pelletier et al. 1997, 1999). Such a global characterization of a significant portion of the flavonoid pathway at the post-transcriptional level has not been done in any other plant species. It is now evident that, at least in *Arabidopsis*, perturbations in flavonoid gene expression do not correlate with intuitive or straightforward predictions of the resulting flavonoid spectra based solely on the current model of the pathway. For instance, whereas mutations in CHI, DFR, or leucoanthocyanidin dioxygenase (LDOX) result in a general increase in other flavonoid enzymes, a mutation in CHS does not show a similar effect. In addition, whereas the CHI mutant, *tt5*, does not show increased levels of sinapate esters (UV-protective compounds that share common p-coumaric acid precursor molecules with flavonoids), the CHS mutant, *tt4*, and the F3H mutant, *tt6*, which are defective in the enzymatic steps immediately before and after CHI-mediated isomerization, respectively, show elevated levels of the same compounds. Thus, there are still undiscovered factors that affect the pathway, which may include mechanisms that incorporate flavonoid intermediates as signaling molecules for the induction of specific enzymes (Pelletier et al. 1999).

### The Flavonoid Metabolon

A concept that is increasingly gaining support as being an important consideration in the control of flavonoid metabolism is the formation of a flavonoid multienzyme complex, or metabolon. This was originally proposed by Stafford (1974) in a review of



aromatic metabolism. In a metabolon configuration, the enzymes are not freely diffusing, but are organized into assemblies that provide most of the catalytic requirements for substrate processing and product formation. The formation of multienzyme complexes is actually a recurring organizational strategy to enhance metabolic efficiency in all organisms. Many critical metabolic processes such as glycolysis, the tricarboxylic acid cycle, and fatty acid oxidation utilize multienzyme complexes for effecting rapid responses to stimuli (Ovadi and Srere 1996). The enhancement of efficiency of enzymes when organized in metabolons is thought to result from a combination of improvements that include, among others, the attainment of high local concentrations of intermediates to favor forward reactions, the prevention of free diffusion of reactive intermediates into the bulk cytosol, and the increased proximity of catalytic sites to each other, facilitating the rapid transfer of intermediates from one catalytic site directly to another (i.e. channeling) until final substrate modifications are completed. The metabolon configuration also affords the cell an efficient means for coordinating pathways that share common intermediates and/or enzymes. In addition, it provides the cell another layer of control over metabolism by regulating the assembly and/or localization of the necessary enzyme complexes. Considering that the concentrations of flavonoid intermediates are vanishingly small, and that most are highly reactive to cytosolic components, the metabolon configuration is an effective strategy for favoring product formation. Such complexes however, have been difficult to study for secondary metabolic pathways due, in part, to relatively weak or unstable interactions between enzymes (Winkel-Shirley 1999). Nonetheless, there is a growing body of evidence supporting the existence of a flavonoid metabolon.

Early circumstantial evidence for a flavonoid multienzyme complex came from the work of Czichi and Kindl (1977). In experiments using etiolated cucumber cotyledons, the first two enzymes of the general phenylpropanoid pathway, phenylalanine ammonia lyase (PAL) and cinnamate-4-hydroxylase (C4H), were observed to co-fractionate in sucrose density gradients. Using the same technique on buckwheat hypocotyl cells, Hrazdina and colleagues found that C4H co-fractionated with CHS, as evidenced by positive activity assays for both enzymes in the same fraction (Hrazdina et al. 1987). A related experiment was performed to demonstrate the occurrence of substrate channeling from PAL to 4-coumarate-CoA-ligase (4CL) (Fig. 1) (Hrazdina and Wagner 1985). When [<sup>3</sup>H]phenylalanine and [<sup>14</sup>C]cinnamate were incubated with a gently-homogenized buckwheat endoplasmic reticulum (ER) membrane preparation, [<sup>3</sup>H]phenylalanine was preferentially incorporated into 4-coumarate (Hrazdina and Wagner, 1985). This was strong evidence that C4H was not as accessible to [<sup>14</sup>C]cinnamate as PAL was to [<sup>3</sup>H]phenylalanine, and suggested that the relative inability of C4H to directly bind its labeled substrate was due to its interaction with PAL and presumably with 4CL in a membrane-bound metabolon configuration. The authors, however, did not succeed in demonstrating channeling into later enzymatic steps.

Compelling new evidence for the flavonoid metabolon has been presented based on work in *Arabidopsis* (Burbulis and Winkel-Shirley 1999; Saslowsky and Winkel-Shirley, *in press*). Using the yeast two-hybrid approach, interactions between CHS, CHI, and DFR were detected. Interactions were further demonstrated in an experiment in which polyclonal anti-CHI antibodies were able to co-immunoprecipitate CHS and F3H from lysates prepared from *Arabidopsis* seedlings. Additional evidence came from affinity

chromatography assays. In these experiments, recombinant CHS or CHI covalently attached to Affi-gel beads were used to recover other flavonoid enzymes from seedling lysates. In a related development, immuno-electron microscopy of *Arabidopsis* root tissue showed that CHS and CHI co-localize in membranous regions of the cytoplasm, including the ER and the cytosolic face of the vacuolar tonoplast. This is consistent with data from immunofluorescence microscopy which shows almost complete convergence of signals for CHS and CHI in root tissue. A surprising asymmetric distribution was found for these enzymes in the root elongation zone, which may point to a specific physiological role of flavonoids in these tissues, perhaps in regulating auxin transport. All this new information underscores the importance of macromolecular organization on flavonoid biosynthesis. This is clearly another layer of regulatory control that has to be studied to enhance our basic understanding of secondary metabolism.

#### The Phage Display Technique for Isolating Antibodies

The introduction of immunological tools was a critical event in modern biology that greatly expanded the realm of questions molecular biologists could address (Knight 1990; Newmark 1985). Subcellular localization of proteins, radioisotope-free tracking of compounds through biosynthetic pathways, elucidation of catalytic sites on enzymes, and knock-outs of key enzymes in a pathway are some of the antibody-facilitated techniques that could be relevant to our research. To this day, however, the production of antibodies has largely relied on animal immunization. An alternative strategy, originally proposed by G. P. Smith in 1985, utilizes filamentous phage engineered to express recombinant antibody molecules on their surface. A major advantage of this technique is that the

isolation of antibodies is done without performing immunizations, thereby completely avoiding constraints imposed by variability in sensitivity and activity of an individual organism's immune system. In addition, screening of a phage display antibody library as described later in this chapter can be accomplished in one week (Fig. 3). Since antigen binders can be identified in as few as two rounds of screening, isolation of antibodies is generally faster with phage display than with immunization-based techniques.

Importantly, since each phage-scFv particle encapsidates the gene that codes for the specific antibody fragment it displays, cloning of antibody genes is straightforward. It was not until the introduction of polymerase chain reaction (PCR) technology, however, that actual experiments demonstrating the feasibility of this approach were carried out (McCafferty et al. 1990).

The diversity of genes encoding antibodies in a stimulated mammalian immune system results from rearrangement of gene components that comprise the complete sequence of an antibody's binding domain. The two primary components that define the ability of an antibody to bind a ligand are the genes encoding the heavy and light variable chains, termed  $V_H$  and  $V_L$ , respectively. Both  $V_H$  and  $V_L$  are typically composed of three hypervariable regions called the complementarity determining regions (CDRs) separated by short, relatively constant segments called the framework regions. Reverse transcription and subsequent PCR amplification of mRNA from naive or immunized B-cells using the known sequences of the framework regions as priming sites allows the direct manipulation of genes encoding the antibodies en masse (i.e. whole repertoires of antibody genes) as described below (Hoogenboom et al. 1992; Hoogenboom and Winter 1992).

To approximate or even surpass the diversity of naturally-occurring antibody repertoires (around  $10^8$  in the murine system), gene alterations affecting one of the three mammalian CDRs of the  $V_H$  have been introduced *in vitro* (Hoogenboom et al. 1992; Hoogenboom and Winter 1992; Nissim et al. 1994). Typically, 50 germline  $V_H$  segments containing the first two CDRs (CDR1 and CDR2) are generated by PCR. These segments are subsequently combined with a collection of artificially-constructed unique CDR3s. Much of the diversity in naturally-occurring repertoires hinges on the relatively extensive sequence and length variation of  $V_H$  CDR3. In fact, substitution of CDR3 alone can be enough to create new antigen binders with entirely different specificities (Hoogenboom and Winter 1992). Thus, much focus has been centered on gene alterations that specifically target this hypervariable region. In the Hoogenboom and Winter library, two pools of  $V_H$  genes were made, one with CDR3 regions coding for a five-residue random peptide, and another with CDR3 regions coding for an additional tripeptide (FDY). When combined with unique germline  $V_L$ s, the resulting diversity is  $2 \times 10^7$  unique binding specificities. The theoretical limit of diversity, however, is higher than  $10^8$ , corresponding to  $1.6 \times 10^8$  different amino acid sequences. The level of diversity observed seems to be limited only by the transformation efficiency of recipient cells and the viability of the cells expressing the resulting gene products. Not all libraries are constructed in this manner. Some researchers are biased against extensive DNA manipulation in library construction because the practice may compromise the proportion of antibody fragments in the library that are functional. In the natural immune response, not all V-gene rearrangements and subsequent  $V_H$  and  $V_L$  pairings are possible because some combinations are highly unstable or even detrimental to the organism that expresses

them. Thus, in an effort to preserve *naturally* rearranged V-genes, full-length V<sub>H</sub> (i.e. including CDR3) and V<sub>L</sub> from non-immunized human B-cell donors have also been used for library construction (Vaughan et al. 1996).

Since the demonstration that foreign proteins could be expressed as fusions to certain subunits of the coat of M13 filamentous phage (Smith 1985), numerous groups have embarked on projects aimed at creating libraries of recombinant M13 phage particles that displayed diverse sets of proteins on the phage coat surface. Such libraries can undergo repeated high-throughput screening for the identification of proteins that may have interesting biological activities such as short random peptides that are mimetic drug candidates (Persic et al. 1997). Phage libraries can also display vast collections of antibody fragments. In fact, repertoires of antibody genes have been expressed as fusions with the M13 pIII or pVIII coat protein. Two routes to antibody gene expression have been pioneered. One route is to express the antibody genes as single chain sequences (i.e. single chain fragment of the variable domain, “scFv”) in which the V<sub>H</sub> gene is joined to the V<sub>L</sub> gene via a short linker sequence (Fig. 4). This strategy uses a single promoter for expression of the scFv. Thus, the resulting fusion protein, by itself, carries a complete antigen-binding domain. A second route is to express the two components of the antigen-binding fragment (Fab), the V<sub>H</sub> linked to a segment of the heavy chain constant domain (Fd) and the V<sub>L</sub> linked to the complete light chain constant domain (Fig. 5). In this strategy, the two Fab components are driven by separate promoters within the phage plasmid in which either the Fd or the light chain sequence is fused to the coat protein gene. Each component is fused to a secretory signal (e.g. the PelB transit peptide). Expression in *E. coli* results in the spontaneous assembly of Fd and the light chain into an

antigen-binding Fab in the periplasmic space. Each phage particle carries the genes encoding the Fab displayed on its surface.

One of the first libraries was derived from human peripheral blood lymphocytes (Marks et al. 1991). In this library, synthetically-rearranged V genes (i.e. a single  $V_L$  gene combined with one of 49 unique  $V_H$  genes each carrying an altered CDR3 region) and naturally-rearranged V genes were represented. These were expressed as scFv fragments fused to the pIII minor coat protein of filamentous phage. Attempts to express scFv's fused to pVIII major coat proteins, which constitute the bulk of the phage coat, have also been made (Greenwood et al., 1991). Comparative analysis of the two types of protein fusions, however, showed that pIII fusions are more immunoreactive (Kretzschmar and Geiser, 1995). Moreover, when molecules larger than hexapeptides were encoded, the phage particles became non-viable unless wild-type pVIII proteins were provided as well (Greenwood et al., 1991).

In 1992, Hoogenboom and Winter built a repertoire of human-derived scFv's entirely *in vitro* (Hoogenboom and Winter 1992). Forty-nine human  $V_H$  segments were amplified using PCR, and subsequently ligated to a synthetically-produced five or eight-residue CDR3 gene. Each rearranged  $V_H$  gene was cloned into an M13 phage vector harboring a single  $V_L$  fused to the pIII coat protein gene. This library had a diversity of  $2 \times 10^7$  unique phage clones. To our knowledge, this was the first successful attempt at isolating antibodies, albeit not to all antigens tested, from a so-called "single pot" of antigen-binders constructed *in vitro*. The library, however, was less than ideal for the isolation of a large range of antigens. It appeared, as the authors concluded, to have a bias for binding haptens, poorly immunogenic substances that need to be coupled to

carrier molecules to elicit an immune response in animals. Subsequently, Nissim et al. (1994) built a similar repertoire of rearranged V-genes completely *in vitro*. Fifty human V<sub>H</sub> segments were ligated to nine families of CDR3s of varying lengths (i.e. encoding 4 to 12 amino acid residues). These were then cloned into M13 phage vectors as in Hoogenboom and Winter's work, resulting in nine libraries of at least 10<sup>7</sup> different clones each. These were combined with Hoogenboom and Winter's library to form a single pot of greater than 10<sup>8</sup> unique clones. From this diverse scFv collection, immunoreactive phage were detected against all 18 antigens tested, demonstrating the feasibility of isolating antibody genes using a single library of diverse repertoires of antigen-binders that completely bypasses immunization. It is from this library that antibodies against our primary enzyme of interest, CHI, were isolated.

Antibody isolation from diverse phage libraries is accomplished through a process that mimics selection in the natural immune system (Figs. 3 and 6). Briefly, in a solid-phase selection strategy, a phage library is incubated in a tube pre-coated with the antigen of interest. Phage displaying relatively high-affinity antigen binders are selected and then eluted. These are amplified in *E. coli* and subsequently rescreened for antigen binding. Through successive cycles of selection, the proportion of high-affinity binders increases, eventually resulting in the identification of isolates carrying antibody genes of interest. However, binders with lower affinities become progressively underrepresented after each screening cycle. Thus, extended screening (i.e. increased number of cycles) can negatively affect the diversity of isolates. In a variation of this basic panning procedure, biotinylated antigen is used to bind phage in solution. Bound phage is subsequently captured using streptavidin-coated paramagnetic beads (Hawkins et al. 1992; Crosby and



Schorr 1995). With either strategy, the genes can be easily recovered via PCR and cloned into a bacterial expression system for the production of soluble antibodies. In some libraries (e.g. the Nissim scFv library), an amber codon is interposed between the scFv gene and the gene for the pIII coat protein. When expressed in a suppressor *E. coli* strain such as TG-1, the amber codon is read as glutamine. This results in fusion of the antibody with the pIII coat protein, and subsequent display on the surface of the phage tip (Marks et al. 1992). Alternatively, the antibodies can be expressed as a soluble, secreted product by phage transfection of a non-suppressor strain such as HB2151. In this strain, the amber codon is read as a stop codon. Thus, the scFv fragment (i.e. not fused to M13) is secreted from the bacteria. Both secreted scFv and phage-scFv particles can be readily used in diagnostic enzyme-linked immunosorbent assays (ELISA). For other protein detection procedures such as Western blotting, both formats can be used. These reagents, however, do not appear to be as easily handled as ordinary immunoglobulin preparations in general immunoblotting procedures and in long-term storage. Presumably, the absence of an F<sub>C</sub> region results in reduced stability of the molecules in secreted form or even as fusions to the phage coat protein.

Of paramount importance to the success of the phage display antibody technique is the size and diversity of the library. In nature, V<sub>H</sub> and V<sub>L</sub> pairings are not always optimal for the formation of physiologically-ideal binding structures, consequently only a fraction of all the possible combinations are selected by the immune system. The methods of library construction do not discriminate against V<sub>H</sub> and V<sub>L</sub> combinations with low binding affinity. Thus, between an immune system and an equally-diverse artificially-constructed library, the chance of isolating a high-affinity binder is much

higher in the former. Increasing the size of the library should enhance the molar amount of high-affinity binders, the majority of which would presumably be natural  $V_H$  and  $V_L$  pairings and the rest would be novel pairings with improved affinities (Hoogenboom et al. 1992; Winter et al. 1994). Recently, other researchers have approached the problem from the opposite direction; instead of increasing library size, they opted to decrease it by weeding out non-specific interactors that comprise the bulk of library “noise” (Kakinuma et al. 1997). However, this approach is limited by the validity of the basic assumption that the library is sufficiently diverse prior to any noise-reduction treatment.

Nonetheless, having a large and diverse library is not sufficient to ensure successful antibody isolation; several other issues must be considered. First, it has been noted that pIII protein fusions are often proteolysed (Winter et al. 1994). Because each phage particle with pIII fusions displays only three to five antibody fragments, proteolysis can render a portion of the phage population “bald,” displaying no antibody fragment at all. Second, the generally rigorous selection process results in only a small fraction of the total potential binders being eluted from the antigen (Hoogenboom et al. 1992).

Therefore, amplification of the library (e.g. from  $10^8$  to  $10^{12}$ ) to generate multiple copies of high-affinity binders (e.g.  $10^4$  copies per unique phage) will help ensure their recovery during the first round of selection.

The literature on successful application of phage display antibody technology is growing. Examples of some of the published work on antibody generation using this technology shows the great potential impact it has on any endeavor requiring immunological techniques (Table 1). A significant proportion of the current body of literature on this technique is comprised of work done using animal systems (i.e. antigens

derived from animals or animal pathogens). Many groups, for instance, have isolated phage-derived antibodies that target specific growth factors such as vascular endothelial growth factors (VEGF) (Zhu et al. 1998) for inhibiting tumor development. In this case, subsequent assays showed that the scFv's blocked tumor angiogenesis, at least *in vitro*. In a related development, another group demonstrated the ability of anti-VEGF scFv's to block tumor angiogenesis in nude mice, reaffirming the strong clinical potential of the scFv approach for diseases involving pathological angiogenesis (Vitaliti et al. 2000). Another tumor growth factor that has recently been targeted is the early pregnancy factor (EPF), an autocrine growth factor for certain tumors. Phage-derived Fab molecules that recognized the target succeeded, to varying degrees, in neutralizing EPF (Hammond et al. 2000). One of the more intriguing possibilities that can be facilitated by the phage display antibody technique is the intracellular expression of antibody genes to block the activity of internalized pathogens. In a feasibility study of a novel therapeutic strategy, phage-derived V<sub>H</sub> fragments that recognize the reverse transcriptase (RT) component of type 1 human immunodeficiency virus (HIV-1) have been shown to inhibit RNA-dependent DNA polymerase activity of HIV-1 RT *in vitro* and *in vivo* using mouse cell cultures (Gargano and Cataneo 1997). Recently, scFv's directed against the UV-induced DNA photoproduct, thymidine(6-4)thymidine, were developed and shown to be capable of distinguishing between UV-irradiated and non-irradiated polythymidylic acid (Zavala et al. 2000). These reagents, although not intended for *in vivo* reactivity studies, provide researchers a means of quantitating the level of deleterious photoproducts in the study of human susceptibility to skin cancer. There are numerous examples of other successful isolations of antibodies through phage display. Moreover, a number of groups have

succeeded in using this technique for identifying antibodies against poorly-immunogenic antigens and even proteins that do not elicit any immune response in most animals (Willems et al. 1998; Fransen et al. 1999; Lekkerkerker and Logtenberg 1999; Stadler 1999; Cyr and Hudspeth 2000). In some cases involving highly enigmatic proteins, it is only through phage display that antibodies were generated (Williams et al. 1996). Clearly, this technique has the potential to enhance all fields in which immunological tools are used.

### Plant Genetic Engineering and the Application of Phage Display Antibody Technique

One of the major consequences of gene sequencing efforts is the improvement of our ability to manipulate organisms at the genetic level. This is particularly evident in the field of crop improvement where genetic engineering is extensively utilized to confer agronomically-important traits to plants. For example, following the elucidation of the gene encoding for the insecticidal protein from *Bacillus thuringiensis* (*Bt*), numerous groups engaged in efforts to mobilize variants of the gene into major crops to confer insect resistance. Several field trials of *Bt*-expressing transgenic plants, which include rice (Tu et al. 2000), soybean (Walker et al. 2000), and maize (Barry et al. 2000), among others, have been conducted, all demonstrating the efficacy of *Bt*-expression against major lepidopteran insect pests. Furthermore, there are now *Bt*-expressing maize and cotton lines that are in commercial use. Another genetic engineering product facilitated by sequencing efforts is the generation of transgenic tomatoes whose ripening is delayed due to the expression of antisense mRNA for polygalacturonase, a key cell wall hydrolase particularly active during tomato fruit ripening (Smith et al. 1990). More recently, a

dominant negative mutation for an ethylene receptor gene, named *etr1-1*, originally identified in *Arabidopsis*, was expressed in transgenic tomato, resulting in delayed ethylene-mediated ripening (Wilkinson et al. 1997).

Simple over-expression of a transgene in plants does not always result in the desired phenotype, however. For instance, drought and salt stress-tolerant bacterial and plant species, such as those belonging to Plumbaginaceae, are known to accumulate osmoprotectants in response to extended periods of water deficit. Glycinebetaines, in particular, accumulate in tolerant bacteria and plants during water stress. With the availability of the gene encoding a key enzyme of glycinebetaine biosynthesis, choline oxidase (*codA*), from a tolerant bacterial species, *Anthrobacter globiformis*, one group attempted to express *codA* in a compartment-specific manner in rice (Sakamoto et al. 1998). Glycinebetaine increased to levels that conferred moderate water stress-tolerance in transgenic rice producing chloroplast-targeted *codA*. However, when a similar choline oxidase gene from *Anthrobacter pascens* was expressed constitutively in *Arabidopsis*, canola, and tobacco, the transgenic plants did not produce physiologically-relevant levels of glycinebetaine that could confer robust stress tolerance (Huang et al. 2000). A dramatic increase of up to 40-fold in glycinebetaine levels, however, was achieved among selected transgenic plants when exogenous choline, the necessary precursor, was applied. The work demonstrates the need to increase endogenous choline levels for the over-expression of choline oxidase to have a significant effect on transgenic plants subjected to stress under field conditions. For certain crop improvement objectives, therefore, over-expression of a single protein or enzyme may not be sufficient. Concomitant increases in the levels of other enzymes may be necessary. In one

metabolic engineering project, for instance, the genes for three carotenoid pathway enzymes, phytoene synthase, phytoene desaturase, and lycopene  $\beta$ -cyclase were introduced into rice for expression in the endosperm, where the carotenoid precursor, geranyl geranyl diphosphate is synthesized (Ye et al. 2000). The feat is particularly remarkable in that an entire branch of the general isoprenoid biosynthetic pathway was successfully installed in a target compartment normally devoid of  $\beta$ -carotene or its immediate precursors. Moreover, the plants were shown to also accumulate the other carotenoid endproducts, zeaxanthin and lutein, suggesting that enzymes necessary for the elaboration of lycopene, the immediate precursor of  $\beta$ -carotene, are constitutively expressed or induced by lycopene or one of the early carotenoid pathway intermediates in the transgenic endosperm.

In metabolic engineering efforts, the usual strategy is to overexpress key enzymes that directly affect the synthesis of the desired endproducts. For projects with the objective of down-regulating a specific enzyme activity, however, many groups have used the anti-sense mRNA or co-suppression strategy. Such a strategy has been particularly useful in the suppression of specific branches of flavonoid biosynthesis in flower color modification. Zuker and colleagues (1998), for instance, used anti-sense F3H mRNA to suppress anthocyanin production, which in turn, transformed carnation from red to uniformly white. Partial suppression of the pathway had also achieved by expression of sense or anti-sense CHS in petunia, resulting in the transformation of purple flowers to predominantly white with novel color patterns (Krol et al. 1988; Napoli et al. 1990). Activation tagging, the technique by which a strong promoter is randomly integrated into the plant chromosome to activate any adjacent downstream gene, has been

very useful in the serendipitous identification of regulators that could be utilized to influence biosynthesis. Such a technique has actually resulted in the production of purple-flowered *Arabidopsis* due to a global increase in phenylpropanoid activity caused by the over-expression of an MYB transcription factor necessary for activating phenylpropanoid genes (Borevitz et al. 2000). The work demonstrates the power of targeting regulators of structural genes in the discovery and production of rare end products that normally exist below the limits of detection.

Another metabolic engineering strategy is to express proteins that directly interact with the target enzyme in a way that alters activity. Phage display appears well-suited for the identification of such proteins, specifically antibody fragments, which can bind targeted enzymes. With this technique, it is conceivable to obtain a collection of different genes that encode metabolism-altering antibodies. Transgenic plants generated using such genes could reveal interesting epitope-dependent phenotypes, possibly leading to insights into the structure of enzymes and potential interactions with other enzymes in substrate processing. Such information cannot be obtained from anti-sense mRNA and co-suppression strategies, whose effects are ultimately based on the reduction or elimination of a specific enzyme activity. There is a growing interest in exploring antibody expression in plants as a novel means for altering metabolism. For instance, antibody genes have been expressed in tobacco to specifically bind phytochrome, resulting in an aberrant phytochrome-dependent germination of transgenic seeds (Owen et al. 1992). As a possible crop protection strategy, scFv's against virus particles have also been expressed in plants, resulting in the successful arrest of systemic invasion (Tavladoraki et al. 1993). Genes encoding antibodies against abscissic acid (ABA) had

also been successfully expressed in tobacco, which led to an ABA-deficient phenotype among the transgenic plants even in the presence of elevated concentrations of exogenous ABA (Artsaenko et al. 1995). In a related development, the same treatment resulted in the blockage of the influence of ABA on stomatal functions, as well as in an aberrant developmental switch in seeds from seed-ripening to vegetative growth (Conrad and Fiedler 1998). All of these experiments, however, utilized sequences of antibodies that originated from immunized animals. More recently, phage-derived scFv's targeted against the *Arabidopsis* cyclin-dependent kinase regulator, CDC2a, have been successfully produced in tobacco cytosol in transient expression assays (Eeckhout et al. 2000). Characterization of transgenic plants to identify *in planta* immunomodulation of the cell cycle is still pending.

Despite these forays into intracellular antibody expression, the phage display technique has not yet been fully utilized in plants. Of particular interest for the field of metabolic engineering is the potential of *in planta* antibodies to modulate the enzymes of a metabolic pathway by direct interdiction. Successful demonstration of this concept should encourage more researchers to explore this technique for altering metabolism. This is a potentially powerful alternative to the current strategies that are exclusively based on manipulation of the actual structural genes and/or the regulatory components of the pathway to effect alterations in metabolism.



## References

- Arimura, G., K. Tashiro, S. Kuhara, T. Nishioka, R. Ozawa and J. Takabayashi (2000).  
“Gene responses in bean leaves induced by herbivory and by herbivore- induced  
volatiles.” Biochem Biophys Res Commun **277**: 305-10.
- Artsaenko, O., M. Peisker, U. zur Nieden, U. Fiedler, E. W. Weiler, K. Muntz and U.  
Conrad (1995). “Expression of a single-chain Fv antibody against abscisic acid  
creates a wilted phenotype in transgenic tobacco.” Plant J **8**: 745-50.
- Baldrige, G. D., N. R. O'Neill and D. A. Samac (1998). “Alfalfa (*Medicago sativa* L.)  
resistance to the root-lesion nematode, *Pratylenchus penetrans*: defense-response  
gene mRNA and isoflavonoid phytoalexin levels in roots.” Plant Mol Biol **38**:  
999-1010.
- Barry, B. D., L. L. Darrah, D. L. Huckla, A. Q. Antonio, G. S. Smith and M. H. O'Day  
(2000). “Performance of transgenic corn hybrids in Missouri for insect control  
and yield.” J Econ Entomol **93**: 993-9.
- Bell, J. N., T. B. Ryder, V. P. Wingate, J. A. Bailey and C. J. Lamb (1986). “Differential  
accumulation of plant defense gene transcripts in a compatible and an  
incompatible plant-pathogen interaction.” Mol Cell Biol **6**: 1615-23.
- Borevitz, J. O., Y. Xia, J. Blount, R. A. Dixon and C. Lamb (2000). “Activation tagging  
identifies a conserved MYB regulator of phenylpropanoid biosynthesis.” Plant  
Cell **12**: 2383-2394.
- Breinholt, V., A. Hossaini, G. W. Svendsen, C. Brouwer and E. Nielsen (2000).  
“Estrogenic activity of flavonoids in mice. The importance of estrogen receptor  
distribution, metabolism and bioavailability.” Food Chem Toxicol **38**: 555-64.

Burbulis, I. E., M. Iacobucci and B. W. Shirley (1996). "A null mutation in the first enzyme of flavonoid biosynthesis does not affect male fertility in *Arabidopsis*."

Plant Cell **8**: 1013-25.

Burbulis, I. E. and B. Winkel-Shirley (1999). "Interactions among enzymes of the *Arabidopsis* flavonoid biosynthetic pathway." Proc Natl Acad Sci U S A **96**:

12929-34.

Cadet, J., C. Anselmino, T. Douki and L. Voituriez (1992). "Photochemistry of nucleic acids in cells." J Photochem Photobiol B **15**: 277-98.

Cain, C. C., D. E. Saslowsky, R. A. Walker and B. W. Shirley (1997). "Expression of chalcone synthase and chalcone isomerase proteins in *Arabidopsis* seedlings."

Plant Mol Biol **35**: 377-81.

Caldwell, M. M., R. Robberecht and S. D. Flint (1983). "Internal filters: prospects for UV-acclimation in higher plants." Physiol Plant **58**: 445-450.

Cardoso, D. F., F. Nato, P. England, M. L. Ferreira, T. J. Vaughan, I. Mota, J. C. Mazie, V. Choumet and P. Lafaye (2000). "Neutralizing human anti-crotoxin scFv isolated from a non-immunized phage library." Scand J Immunol **51**: 337-44.

Charrier, B., C. Coronado, A. Kondorosi and P. Ratet (1995). "Molecular characterization and expression of alfalfa (*Medicago sativa* L.) flavanone-3-hydroxylase and dihydroflavonol-4-reductase encoding genes." Plant Mol Biol **29**: 773-86.

Chow, W. S., A. Strid and J. M. Anderson (1992). "Short-term treatment of pea plants with supplementary UVB radiation: recovery time-courses of some

- photosynthetic functions and components.” In: Research in Photosynthesis. N Murata, ed. Kluwer Academic Publishers, Dordrecht.
- Christie, J. M. and G. I. Jenkins (1996). “Distinct UV-B and UV-A/blue light signal transduction pathways induce chalcone synthase gene expression in *Arabidopsis* cells.” Plant Cell **8**: 1555-67.
- Conrad, U. and U. Fiedler (1998). “Compartment-specific accumulation of recombinant immunoglobulins in plant cells: an essential tool for antibody production and immunomodulation of physiological functions and pathogen activity.” Plant Mol Biol **38**: 101-9.
- Constantinou, A., R. Mehta, C. Runyan, K. Rao, A. Vaughan and R. Moon (1995). “Flavonoids as DNA topoisomerase antagonists and poisons: structure- activity relationships.” J Nat Prod **58**: 217-25.
- Crosby, W. L. and P. Schorr (1995). “Principles and applications of recombinant antibody phage display technology to plant biology.” Methods Cell Biol **50**: 85-99.
- Cyr, J. L. and A. J. Hudspeth (2000). “A library of bacteriophage-displayed antibody fragments directed against proteins of the inner ear.” Proc Natl Acad Sci U S A **97**: 2276-81.
- Czichi, U. and H. Kindl (1977). “Phenylalanine ammonia lyase and cinnamic acid hydroxylases as assembled consecutive enzymes on microsomal membranes of cucumber cotyledons: cooperation and subcellular distribution.” Planta **134**: 133-143.

- Day, T. A., G. Martin and T. C. Vogelmann (1993). "Penetration of UV-B in foliage: evidence that the epidermis does not behave as a non-uniform filter." Plant Cell Environ **16**: 735-741.
- Deboo, G. B., M. C. Albertsen and L. P. Taylor (1995). "Flavanone 3-hydroxylase transcripts and flavonol accumulation are temporally coordinate in maize anthers." Plant J **7**: 703-13.
- Denis, L., M. S. Morton and K. Griffiths (1999). "Diet and its preventive role in prostatic disease." Eur Urol **35**: 377-87.
- Dixon, R. A. and C. L. Steele (1999). "Flavonoids and isoflavonoids - a gold mine for metabolic engineering." Trends Plant Sci **4**: 394-400.
- Dooner, H. K., T. Robbins and R. Jorgensen (1991). "Genetic and developmental control of anthocyanin biosynthesis." Annu Rev Genet **25**: 173-199.
- Ebel, J., W. E. Schmidt and R. Loyal (1984). "Phytoalexin synthesis in soybean cells: elicitor induction of phenylalanine ammonia-lyase and chalcone synthase mRNAs and correlation with phytoalexin accumulation." Arch Biochem Biophys **232**: 240-8.
- Eeckhout, D., E. Fiers, R. Sienaert, V. Snoeck, A. Depicker and G. De Jaeger (2000). "Isolation and characterization of recombinant antibody fragments against CDC2a from *Arabidopsis thaliana*." Eur J Biochem **267**: 6775-83.
- Fransen, M., P. P. Van Veldhoven and S. Subramani (1999). "Identification of peroxisomal proteins by using M13 phage protein VI phage display: molecular evidence that mammalian peroxisomes contain a 2,4-dienoyl-CoA reductase." Biochem J **340**: 561-8.

- Fisher R. F. and S. R. Long (1992). “*Rhizobium*-plant signal exchange.” Nature **357**: 665-660.
- Fuglevand, G., J. A. Jackson and G. I. Jenkins (1996). “UV-B, UV-A, and blue light signal transduction pathways interact synergistically to regulate chalcone synthase gene expression in *Arabidopsis*.” Plant Cell **8**: 2347-57.
- Gargano, N. and A. Cattaneo (1997). “Inhibition of murine leukaemia virus retrotranscription by the intracellular expression of a phage-derived anti-reverse transcriptase antibody fragment.” J Gen Virol **78**: 2591-9.
- Glassgen, W. E., A. Rose, J. Madlung, W. Koch, J. Gleitz and H. U. Seitz (1998). “Regulation of enzymes involved in anthocyanin biosynthesis in carrot cell cultures in response to treatment with ultraviolet light and fungal elicitors.” Planta **204**: 490-8.
- Greenwood J., A. E. Willis and R. N. Perham (1991). “Multiple display of foreign peptides on a filamentous bacteriophage.” J Mol Biol **220**: 821-827.
- Griffiths, K., M. S. Morton and L. Denis (1999). “Certain aspects of molecular endocrinology that relate to the influence of dietary factors on the pathogenesis of prostate cancer.” Eur Urol **35**: 443-55.
- Hahlbrock, K. (1981). “Flavonoids.” In: *The Biochemistry of Plants*, vol 7. Academic Press, New York.
- Hahlbrock, K. and D. Scheel (1989). “Physiology and molecular biology of phenylpropanoid metabolism.” In: *Annu Rev Plant Physiol Plant Mol Biol*. **40**: 347-369.

- Hammond, F., A. Cavanagh, H. Morton, N. Hillyard, A. Papaioannou, M. Clark, D. Wanigsekera, M. Swanton and R. Ward (2000). "Isolation of antibodies which neutralise the activity of early pregnancy factor." J Immunol Methods **244**: 175-84.
- Harborne, J. B. and C. A. Williams (2000). "Advances in flavonoid research since 1992." Phytochemistry **55**: 481-504.
- Harper, K., R. J. Kerschbaumer, A. Ziegler, S. M. Macintosh, G. H. Cowan, G. Himmler, M. A. Mayo and L. Torrance (1997). "A scFv-alkaline phosphatase fusion protein which detects potato leafroll luteovirus in plant extracts by ELISA." J Virol Methods **63**: 237-42.
- Hawkins, R. E., S. J. Russell and G. Winter (1992). "Selection of phage antibodies by binding affinity. Mimicking affinity maturation." J Mol Biol **226**: 889-96.
- Hoogenboom, H. R., J. D. Marks, A. D. Griffiths and G. Winter (1992). "Building antibodies from their genes." Immunol Rev **130**: 41-68.
- Hoogenboom, H. R. and G. Winter (1992). "By-passing immunisation: human antibodies from synthetic repertoires of germline VH gene segments rearranged in vitro." J Mol Biol **227**: 381-8.
- Hrazdina, G. and G. J. Wagner (1985). "Metabolic pathways as enzyme complexes: evidence for the synthesis of phenylpropanoids and flavonoids on membrane associated enzyme complexes." Arch Biochem Biophys **237**(1): 88-100.
- Hrazdina, G., A. M. Zobel and H. C. Hoch (1987). "Biochemical, immunological, and immunocytochemical evidence for the association of chalcone synthase with endoplasmic reticulum membranes." Proc Natl Acad Sci U S A **84**: 8966-70.

- Huang, J., R. Hirji, L. Adam, K. L. Rozwadowski, J. K. Hammerlindl, W. A. Keller and G. Selvaraj (2000). "Genetic engineering of glycinebetaine production toward enhancing stress tolerance in plants: metabolic limitations." Plant Physiol **122**: 747-56.
- Jordan, B. R., P. E. James and S. A. H.-Mackerness (1998). "Factors affecting UV-B-induced changes in *Arabidopsis thaliana* L. gene expression: the role of development, protective pigments and the chloroplast signal." Plant Cell Physiol **39**: 769-78.
- Jordan, B. R., P. E. James, A. Strid and R. G. Anthony (1994). "The effect of ultraviolet-B radiation on gene expression and pigment composition in etiolated and green pea leaf tissue: UV-B induced changes are gene specific and dependent upon the developmental stage." Plant Cell Environ **17**: 45-54.
- Kakinuma, A., S. Portolano, G. Chazenbalk, B. Rapoport and S. M. McLachlan (1997). "Insight into screening immunoglobulin gene combinatorial libraries in a phage display vector: a tale of two antibodies." Autoimmunity **25**: 73-84.
- Knight P. (1990). "Monoclonal antibodies as reagents." Bio/Technology **8**: 59-60.
- Koes, R. E., F. Quattrocchio, J. N. M. Mol (1994). "The flavonoid biosynthetic pathway in plants: function and evolution." BioEssays **16**:123-132.
- Kootstra, A. (1994). "Protection from UV-B-induced DNA damage by flavonoids." Plant Mol Biol **26**: 771-4.
- Kretzschmar T. and M. Geiser (1995). "Evaluation of antibodies fused to minor coat protein III and major coat protein VIII of bacteriophage M13." Gene **155**: 61-65.

- Krol, A. R. van der, P. E. Lenting, J. Veenstra, I. M. van der Meer, R. E. Koes, A. G. M. Gerats, J. N. M. Mol and A. R. Stuitje (1988). "An anti-sense chalcone synthase gene in transgenic plants inhibits flower pigmentation." Nature **833**: 866-869.
- Kubasek, W. L., F. M. Ausubel and B. W. Shirley (1998). "A light-independent developmental mechanism potentiates flavonoid gene expression in *Arabidopsis* seedlings." Plant Mol Biol **37**: 217-23.
- Kupsch, J. M., N. H. Tidman, N. V. Kang, H. Truman, S. Hamilton, N. Patel, J. A. Newton Bishop, I. M. Leigh and J. S. Crowe (1999). "Isolation of human tumor-specific antibodies by selection of an antibody phage library on melanoma cells." Clin Cancer Res **5**: 925-31.
- Landry, L. G., C. C. Chapple and R. L. Last (1995). "*Arabidopsis* mutants lacking phenolic sunscreens exhibit enhanced ultraviolet-B injury and oxidative damage." Plant Physiol **109**: 1159-66.
- Lekkerkerker, A. and T. Logtenberg (1999). "Phage antibodies against human dendritic cell subpopulations obtained by flow cytometry-based selection on freshly isolated cells." J Immunol Methods **231**: 53-63.
- Li, J., T.-M. Ou-Lee, R. Raba, R. G. Amudson and R. L. Last (1993). "*Arabidopsis* flavonoid mutants are hypersensitive to UV-B irradiation." Plant Cell **5**: 171-179.
- Ludwig, S. R. and S. R. Wessler (1990). "Maize R gene family: tissue-specific helix-loop-helix proteins." Cell **62**: 849-851.
- Marks, J. D., A. D. Griffiths, M. Malmqvist, T. P. Clackson, J. M. Bye and G. Winter (1992). "By-passing immunization: building high affinity human antibodies by chain shuffling." Biotechnology (N Y) **10**: 779-83.



- Marks, J. D., H. R. Hoogenboom, T. P. Bonnert, J. McCafferty, A. D. Griffiths and G. Winter (1991). "By-passing immunization: human antibodies from V-gene libraries displayed on phage." J Mol Biol **222**: 581-97.
- Martin, C. and T. Gerats (1993). "The control of pigment biosynthesis during petal development." Plant Cell **5**: 1253-1264.
- McCafferty, J., A. D. Griffiths, G. Winter and D. J. Chiswell (1990). "Phage antibodies: filamentous phage displaying antibody variable domains." Nature **348**: 552-4.
- McKhann, H. I. and A. M. Hirsch (1994). "Isolation of chalcone synthase and chalcone isomerase cDNAs from alfalfa (*Medicago sativa* L.): highest transcript levels occur in young roots and root tips." Plant Mol Biol **24**: 767-77.
- Mitchell, D. L. and R. S. Nairns (1989). "The biology of the (6-4) photoproduct." Photochem Photobiol **49**: 805-819.
- Mooney, M., T. Desnos, K. Harrison, J. Jones, R. Carpenter and E. Coen (1995). "Altered regulation of tomato and tobacco pigmentation genes caused by the delila gene of *Antirrhinum*." Plant J **7**: 333-339.
- Moyano, E., J. F. Martinez-Garcia and C. Martin (1996). "Apparent redundancy in myb gene function provides gearing for the control of flavonoid biosynthesis in *Antirrhinum* flowers." Plant Cell **8**: 1519-32.
- Murphy, A., W. A. Peer and L. Taiz (2000). "Regulation of auxin transport by aminopeptidases and endogenous flavonoids." Planta **211**: 315-24.
- Napoli, C. A., D. Fahy, H. Y. Wang and L. P. Taylor (1999). "white anther: A petunia mutant that abolishes pollen flavonol accumulation, induces male sterility, and is complemented by a chalcone synthase transgene." Plant Physiol **120**: 615-22.

- Napoli, C. A., C. Lemieux and R. Jorgensen (1990). "Introduction of chimeric chalcone synthase gene into petunia results in reversible co-suppression of homologous gene in trans." Plant Cell **2**: 279-289.
- Newmark P. (1985). "The many merits of monoclonals." Nature **316**: 387.
- Nissim, A., H. R. Hoogenboom, I. M. Tomlinson, G. Flynn, C. Midgley, D. Lane and G. Winter (1994). "Antibody fragments from a 'single pot' phage display library as immunochemical reagents." Embo J **13**: 692-8.
- Ovadi, J. and P. A. Srere (1996). "Metabolic consequences of enzyme interactions." Cell Biochem Funct **14**: 249-58.
- Owen, M., A. Gandecha, B. Cockburn and G. Whitlam (1992). "Synthesis of a functional anti-phytochrome single-chain Fv protein in transgenic tobacco." Biotechnology (N Y) **10**: 790-4.
- Pelletier, M. K., I. E. Burbulis and B. Winkel-Shirley (1999). "Disruption of specific flavonoid genes enhances the accumulation of flavonoid enzymes and end-products in *Arabidopsis* seedlings." Plant Mol Biol **40**: 45-54.
- Pelletier, M. K., J. R. Murrell and B. W. Shirley (1997). "Characterization of flavonol synthase and leucoanthocyanidin dioxygenase genes in *Arabidopsis*. Further evidence for differential regulation of "early" and "late" genes." Plant Physiol **113**: 1437-45.
- Persic, L., M. Righi, A. Roberts, H. R. Hoogenboom, A. Cattaneo and A. Bradbury (1997). "Targeting vectors for intracellular immunisation." Gene **187**: 1-8.
- Peters, N. K., J. W. Frost and S. R. Long (1986). "A plant flavone, luteolin, induces expression of *Rhizobium meliloti* nodulation genes." Science **233**: 977-80.

- Peters, N. K. and S. R. Long (1988). “*Rhizobium meliloti* nodulation gene inducers and inhibitors.” Plant Physiol **88**: 396-400.
- Quattrocchio, F., J. F. Wing, H. T. C. Leppen, J. N. M. Mol and R. E. Koes (1993). “Regulatory genes controlling anthocyanin pigmentation are functionally conserved among plant species and have distinct sets of target genes.” Plant Cell **5**: 1497-1512.
- Quattrocchio, F., J. F. Wing, K. van der Woude, J. N. M. Mol and R. E. Koes (1998). “Analysis of bHLH and MYB-domain proteins: Species-specific differences are caused by divergent evolution of target anthocyanin genes.” Plant J **13**: 475-488.
- Rice-Evans, C. A., N. J. Miller, P. G. Bolwell, P. M. Bramley and J. B. Pridham (1995). “The relative antioxidant activities of plant-derived polyphenolic flavonoids.” Free Radic Res **22**: 375-83.
- Richard, S., G. Lapointe, R. G. Rutledge and A. Seguin (2000). “Induction of chalcone synthase expression in white spruce by wounding and jasmonate.” Plant Cell Physiol **41**: 982-7.
- Roberts, E. A. H. (1960). “Effect of glycosylation on the enzymic oxidation and translocation of flavonoids.” Nature **185**: 536-537.
- Rubery, P. H. (1990). “Phytotropins: receptors and endogenous ligands.” Symp Soc Exp Biol **44**: 119-46.
- Ryder, T. B., S. A. Hedrick, J. N. Bell, X. W. Liang, S. D. Clouse and C. J. Lamb (1987). “Organization and differential activation of a gene family encoding the plant defense enzyme chalcone synthase in *Phaseolus vulgaris*.” Mol Gen Genet **210**: 219-33.

- Sakamoto, A., Alia, N. Murata and A. Murata (1998). "Metabolic engineering of rice leading to biosynthesis of glycinebetaine and tolerance to salt and cold." Plant Mol Biol **38**: 1011-9.
- Saslowky, D. and B. S. J. Winkel-Shirley (2001). "Localization of flavonoid enzymes in *Arabidopsis thaliana* roots." Plant J in press.
- Schlaman H. R. M., R. J. H. Okker and B. J. J. Lugtenberg (1992). "Regulation of nodulation gene expression by *NodD* in *Rhizobia*." J Bacteriol **174**: 5177-5182.
- Schmelzer, E., W. Jahnen and K. W. Hahlbrock (1988). "*In situ* localization of light-induced chalcone synthase mRNA, chalcone synthase, and flavonoid end-products in epidermal cells of parsley leaves." Proc Natl Acad Sci USA **85**: 2989-93.
- Schnitzler, J. P., T. P. Jungblut, W. Heller, M. Kofferlein, P. Hutzler, U. Heinzmann, E. Schmelzer, D. Ernst, C. Langebartels and H. Sandermann Jr (1996). "Tissue localization of UV-B screening pigments and of chalcone synthase mRNA in needles of scots pine seedlings." New Phytol **132**: 247-258.
- Shirley, B. W., S. Hanley and H. M. Goodman (1992). "Effects of ionizing radiation on a plant genome: analysis of two *Arabidopsis transparent testa* mutations." Plant Cell **4**: 333-347.
- Shirley, B. W., W. L. Kubasek, G. Storz, E. Bruggemann, M. Koornneef, F. M. Ausubel and H. M. Goodman (1995). "Analysis of *Arabidopsis* mutants deficient in flavonoid biosynthesis." Plant J **8**: 659-71.
- Smith, C. J., C. F. Watson, P. C. Morris, C. R. Bird, G. B. Seymour, J. E. Gray, C. Arnold, G. A. Tucker, W. Schuch, S. Harding and et al. (1990). "Inheritance and

- effect on ripening of antisense polygalacturonase genes in transgenic tomatoes.”  
Plant Mol Biol **14**: 369-79.
- Smith, G. P. (1985). “Filamentous fusion phage: novel expression vectors that display cloned antigens on the virion surface.” Science **228**: 1315-7.
- Spelt, C., F. Quattrocchio, J. N. Mol and R. Koes (2000). “Anthocyanin1 of petunia encodes a basic helix-loop-helix protein that directly activates transcription of structural anthocyanin genes.” Plant Cell **12**: 1619-32
- Stadler, B. M. (1999). “Antibody production without animals.” Dev Biol Stand **101**: 45-8.
- Stafford, H. A. (1974). “The metabolism of aromatic compounds.” Annu Rev Plant Physiol **25**: 459-486.
- Stafford, H. A. (1990). “Flavonoid Metabolism.” CRC Press, Boca Raton, Florida.
- Stapleton, A. E. and V. Walbot (1994). “Flavonoids can protect maize DNA from the induction of ultraviolet radiation damage.” Plant Physiol **105**: 881-9.
- Swain, T. (1976). “Nature and Properties of Flavonoids.” In: Chemistry and Biochemistry of Plant Products. TW Goodwin, ed. Academic Press, New York.
- Tavladoraki, P., E. Benvenuto, S. Trinca, D. De Martinis, A. Cattaneo and P. Galeffi (1993). “Transgenic plants expressing a functional single-chain Fv antibody are specifically protected from virus attack.” Nature **366**: 469-72.
- Taylor, L. P. and W. R. Briggs (1990). “Genetic regulation and photocontrol of anthocyanin accumulation in maize seedlings.” Plant Cell **2**: 115-127.
- Toguri, T., N. Umemoto, O. Kobayashi and T. Ohtani (1993). “Activation of anthocyanin synthesis genes by white light in eggplant hypocotyl tissues, and identification of an inducible P-450 cDNA.” Plant Mol Biol **23**: 933-46.

- Tu, J., G. Zhang, K. Datta, C. Xu, Y. He, Q. Zhang, G. S. Khush and S. K. Datta (2000).  
“Field performance of transgenic elite commercial hybrid rice expressing *Bacillus thuringiensis* delta-endotoxin.” Nat Biotechnol **18**: 1101-4.
- Tyutyulkova, S., Q. S. Gao, A. Thompson, S. Rennard and S. Paul (1996). “Efficient vasoactive intestinal polypeptide hydrolyzing autoantibody light chains selected by phage display.” Biochim Biophys Acta **1316**: 217-23.
- van der Meer, I. M., M. E. Stam, A. J. van Tunen, J. N. Mol and A. R. Stuitje (1992).  
“Antisense inhibition of flavonoid biosynthesis in petunia anthers results in male sterility.” Plant Cell **4**: 253-62.
- van Eldik, G. J., W. H. Reijnen, R. K. Ruiters, M. M. van Herpen, J. A. Schrauwen and G. J. Wullems (1997). “Regulation of flavonol biosynthesis during anther and pistil development, and during pollen tube growth in *Solanum tuberosum*.” Plant J **11**: 105-13.
- van Rhijn, P. and J. Vanderleyden (1995). “The *Rhizobium*-plant symbiosis.” Microbiol Rev **59**: 124-42.
- Vaughan, T. J., A. J. Williams, K. Pritchard, J. K. Osbourn, A. R. Pope, J. C. Earnshaw, J. McCafferty, R. A. Hodits, J. Wilton and K. S. Johnson (1996). “Human antibodies with sub-nanomolar affinities isolated from a large non-immunized phage display library.” Nat Biotechnol **14**: 309-14.
- Verpoorte, R., R. van der Heijden, H. J. G. ten Hoopen and J. Memelink (1999).  
“Metabolic engineering of plant secondary metabolite pathways for the production of fine chemicals.” Biotechnol Lett **21**: 467-479.

- Vitaliti, A., M. Wittmer, R. Steiner, L. Wyder, D. Neri and R. Klemenz (2000).  
“Inhibition of tumor angiogenesis by a single-chain antibody directed against  
vascular endothelial growth factor.” Cancer Res **60**: 4311-4.
- Walker, A. R., P. A. Davison, A. C. Bolognesi-Winfield, C. M. James, N. Srinivasan, T.  
L. Blundell, J. J. Esch, M. D. Marks and J. C. Gray (1999). “The Transparent  
Testa Glabra1 locus, which regulates trichome differentiation and anthocyanin  
biosynthesis in *Arabidopsis*, encodes a WD40 repeat protein.” Plant Cell **11**:  
1337-50.
- Walker, D. R., J. N. All, R. M. McPherson, H. R. Boerma and W. A. Parrott (2000).  
“Field evaluation of soybean engineered with a synthetic cry1Ac transgene for  
resistance to corn earworm, soybean looper, velvetbean caterpillar (Lepidoptera:  
Noctuidae), and lesser cornstalk borer (Lepidoptera: Pyralidae).” J Econ Entomol  
**93**: 613-22.
- Waser, N. M. and M. V. Price (1983). “Pollinator behaviour and natural selection for  
flower color in *Delphinium nelsonii*.” Nature **302**: 422-424.
- Wellmann, E. (1975). “UV dose-dependent induction of enzymes related to flavonoid  
biosynthesis in cell suspension cultures of parsley.” FEBS Lett **51**: 105-7.
- Wilkinson, J. Q., M. B. Lanahan, D. G. Clark, A. B. Bleecker, C. Chang, E. M.  
Meyerowitz and H. J. Klee (1997). “A dominant mutant receptor from  
*Arabidopsis* confers ethylene insensitivity in heterologous plants.” Nat Biotechnol  
**15**: 444-7.
- Willems, P. M., R. M. Hoet, E. L. Huys, J. M. Raats, E. J. Mensink and R. A. Raymakers  
(1998). “Specific detection of myeloma plasma cells using anti-idiotypic single

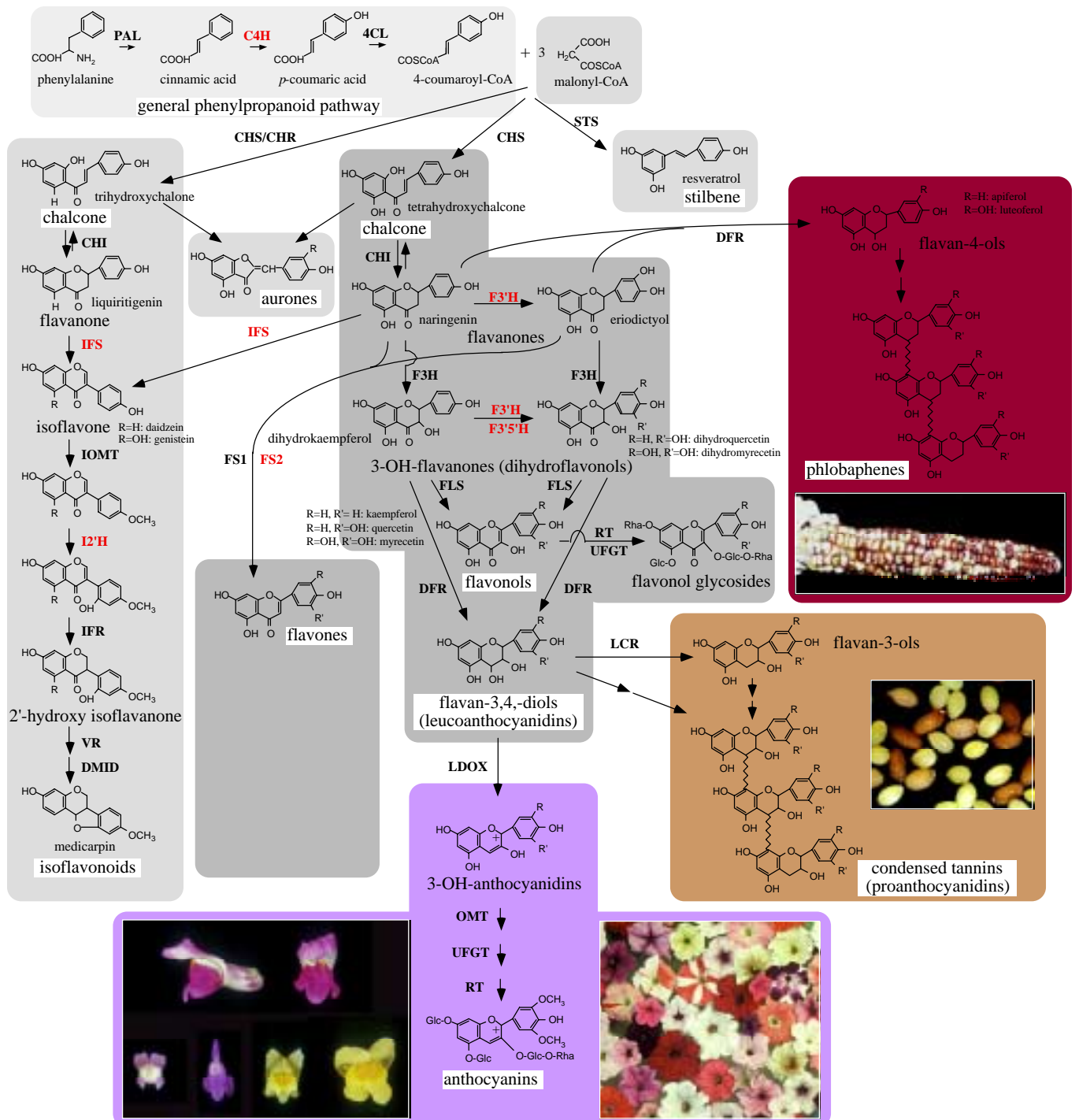
- chain antibody fragments selected from a phage display library.” Leukemia **12**: 1295-302.
- Williams, M. N., G. Freshour, A. G. Darvill, P. Albersheim and M. G. Hahn (1996). “An antibody Fab selected from a recombinant phage display library detects deesterified pectic polysaccharide rhamnogalacturonan II in plant cells.” Plant Cell **8**: 673-85.
- Winkel-Shirley, B. S. J. (2001). “A colorful model for genetics, biochemistry, cell biology, and biotechnology.” Plant Physiol *in press*.
- Winkel-Shirley, B. S. J. (1999). “Evidence of enzyme complexes in the phenylpropanoid and flavonoid pathways.” Physiol Plant **107**: 142-149.
- Winter, G., A. D. Griffiths, R. E. Hawkins and H. R. Hoogenboom (1994). “Making antibodies by phage display technology.” Annu Rev Immunol **12**: 433-55.
- Xu, P., T. Vogt and L. P. Taylor (1997). “Uptake and metabolism of flavonols during in-vitro germination of *Petunia hybrida* (L.) pollen.” Planta **202**: 257-265.
- Yang, W. C., H. C. J. Canter-Cremers, P. Hogendijk, P. Katinakis, C. A. Wijffelman, H. Franssen, A. Van Kammen and T. Bisseling (1992). “*In situ* localization of chalcone synthase mRNA in pea root nodule development.” Plant J **2**: 143-151.
- Ye, X., S. Al-Babili, A. Klotti, J. Zhang, P. Lucca, P. Beyer and I. Potrykus (2000). “Engineering the provitamin A (beta-carotene) biosynthetic pathway into (carotenoid-free) rice endosperm.” Science **287**: 303-5.
- Zaat, S. A., J. Schripsema, C. A. Wijffelman, A. A. van Brussel and B. J. Lugtenberg (1989). “Analysis of the major inducers of the *Rhizobium nodA* promoter from

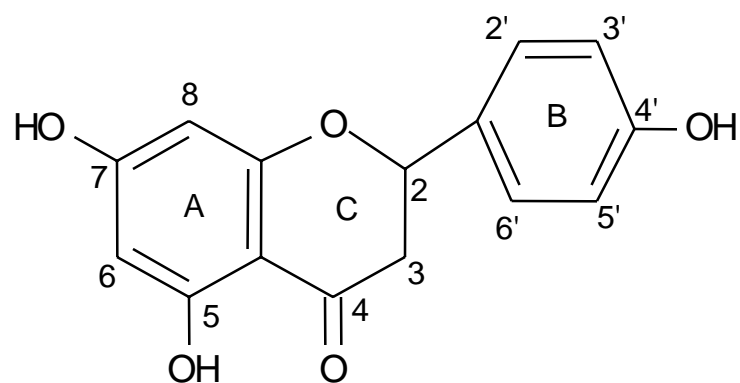


- Vicia sativa* root exudate and their activity with different *nodD* genes.” Plant Mol Biol **13**: 175-88.
- Zaat, S. A., C. A. Wijffelman, H. P. Spaink, A. A. van Brussel, R. J. Okker and B. J. Lugtenberg (1987). “Induction of the *nodA* promoter of *Rhizobium leguminosarum* Sym plasmid pRL1JI by plant flavanones and flavones.” J Bacteriol **169**: 198-204.
- Zand, R. S., D. J. Jenkins and E. P. Diamandis (2000). “Steroid hormone activity of flavonoids and related compounds.” Breast Cancer Res Treat **62**: 35-49.
- Zavala, A. G., T. Lancaster, J. D. Groopman, P. T. Strickland and S. Chandrasegaran (2000). “Phage display of scFv peptides recognizing the thymidine(6-4)thymidine photoproduct.” Nucleic Acids Res **28**: E24.
- Zebedee, S. L., C. F. Barbas, Y. L. Hom, R. H. Caothien, R. Graff, J. DeGraw, J. Pyati, R. LaPolla, D. R. Burton, R. A. Lerner and et al. (1992). “Human combinatorial antibody libraries to hepatitis B surface antigen.” Proc Natl Acad Sci U S A **89**: 3175-9.
- Zhu, Z., P. Rockwell, D. Lu, H. Kotanides, B. Pytowski, D. J. Hicklin, P. Bohlen and L. Witte (1998). “Inhibition of vascular endothelial growth factor-induced receptor activation with anti-kinase insert domain-containing receptor single- chain antibodies from a phage display library.” Cancer Res **58**: 3209-14.
- Ziegler, A., L. Torrance, S. M. Macintosh, G. H. Cowan and M. A. Mayo (1995). “Cucumber mosaic cucumovirus antibodies from a synthetic phage display library.” Virology **214**: 235-8.

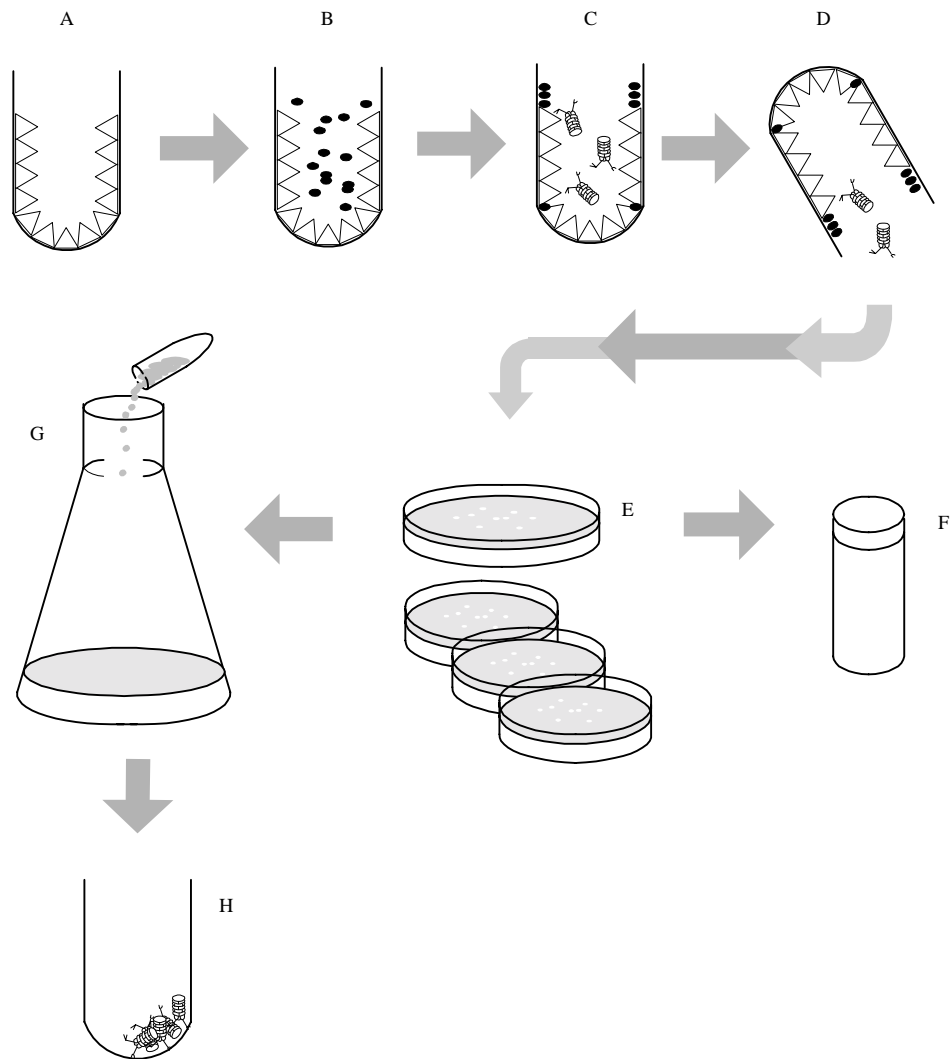
Zuker A., T. Tzfira and A. Vainstein (1998). “Genetic engineering for cut-flower improvement.” Biotechnol Adv **16**: 33-79.

**Figure 1.** Schematic of the major branch pathways of flavonoid biosynthesis (reviewed in Winkel-Shirley 2001), starting with general phenylpropanoid metabolism and leading to the nine major subgroups: the colorless chalcones, aurones, isoflavonoids, flavones, flavonols and flavandiols (gray boxes), and the anthocyanins, condensed tannins, and phlobaphene pigments (colored boxes). P450 hydroxylases that may function as membrane anchors for multienzyme assemblies are indicated in red. The photographs illustrate the three major classes of pigments in the model plants, *Antirrhinum majus*, *Arabidopsis thaliana*, *Zea maize*, and *Petunia hybrida*. Root nodulation by rhizobia, which involves flavone as well as flavanone and isoflavone signal molecules, is also shown, in this case for *Melilotus alba* (sweetclover). Enzyme names are abbreviated as follows: cinnamate-4-hydroxylase (C4H), chalcone isomerase (CHI), chalcone reductase (CHR), chalcone synthase (CHS), 4-coumaroyl:CoA-ligase (4CL), dihydroflavonol 4-reductase (DFR), 7,2'-dihydroxy, 4'-methoxyisoflavanol dehydratase (DMID), flavanone 3-hydroxylase (F3H), flavone synthase (FSI and FSII), flavonoid 3' or 3'5' hydroxylase (F3'H, F3'5'H), isoflavone *O*-methyltransferase (IOMT), isoflavone reductase (IFR), isoflavone 2'-hydroxylase (I2'H), isoflavone synthase (IFS), leucoanthocyanidin dioxygenase (LDOX), leucoanthocyanidin reductase (LCR), *O*-methyltransferase (OMT), phenylalanine ammonia-lyase (PAL), rhamnosyl transferase (RT), stilbene synthase (STS), UDP flavonoid glucosyl transferase (UFGT), vestitone reductase (VR). Photographs are courtesy of Cathie Martin at John Innes Centre (*Antirrhinum*), Francesca Quattrocchio of the Free University in Amsterdam (petunia), Erich Grotewold at Ohio State University (maize), and Yimei Lin and Ann Hirsch (sweetclover).

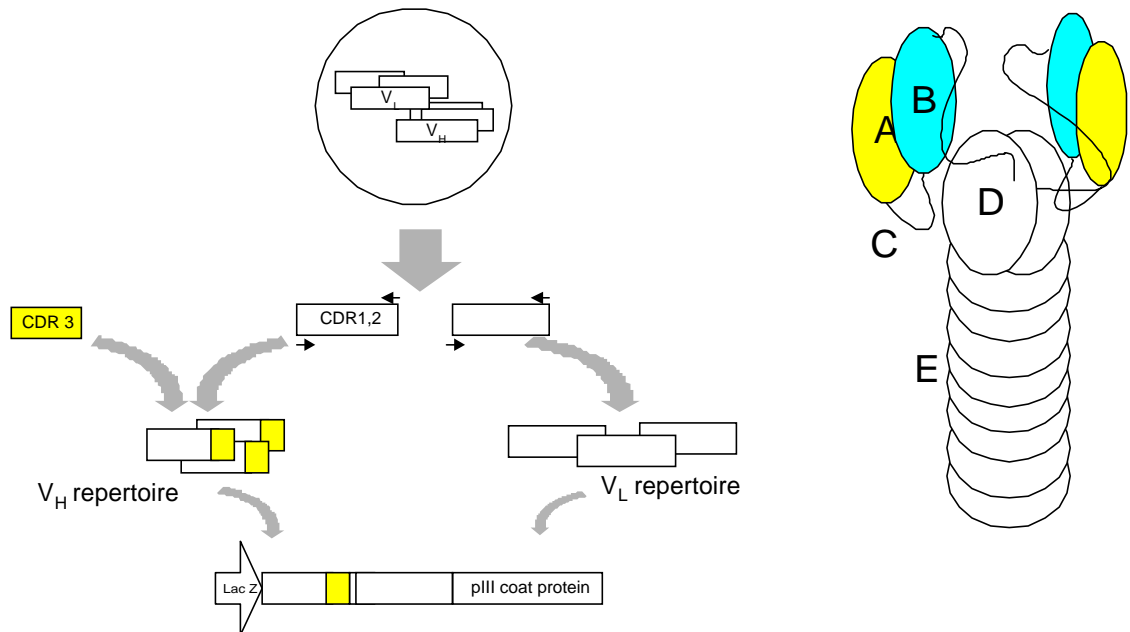




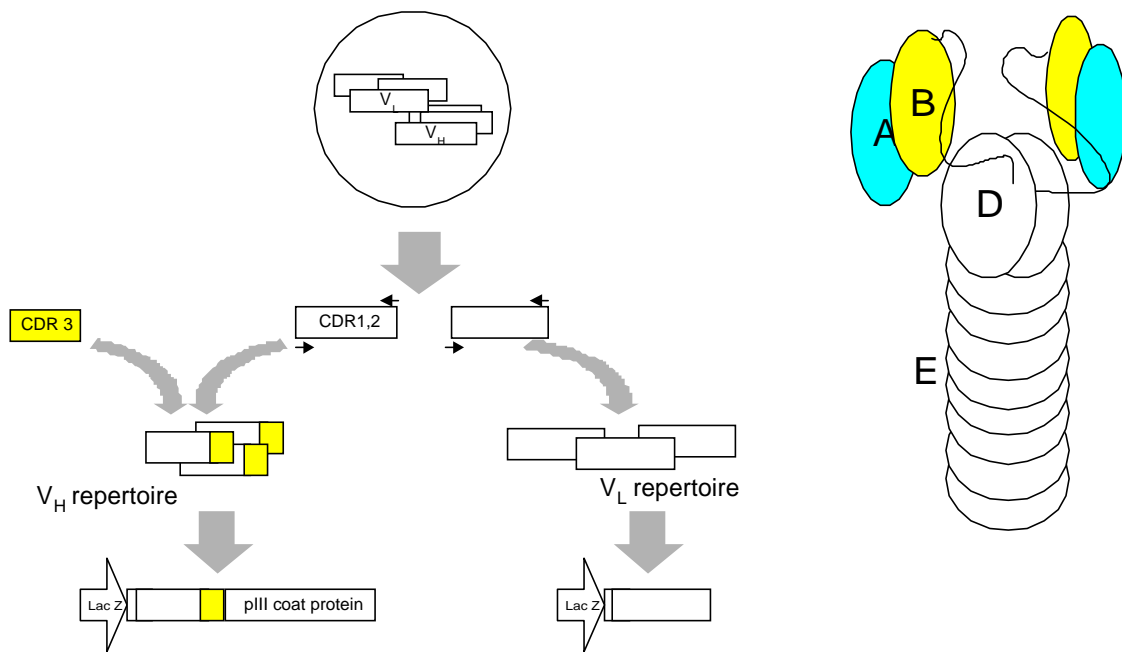
**Figure 2.** Numbering scheme for the basic  $C_{15}$  structure of flavonoid molecules. Shown above is naringenin, the direct product of chalcone isomerase. Three rings, identified in the diagram as A, B, and C, are common to many flavonoids. However, some flavonoids, like the naringenin precursor, naringenin chalcone, only have rings A and B tethered by a three-carbon chain.



**Figure 3.** Protocol for selecting antigen binders from a phage display antibody library. A: Immunotube is coated with antigen overnight. B: Tube is blocked with milk. C: Phage library is incubated in the tube. D: Phage particles that bind to antigen are eluted. A fresh *E. coli* TG-1 solution is transfected with the eluted phage. E: A portion of the transfected culture is used for estimating the titre of the antigen binders (depicted above as three small plates). The remainder is plated on a large bioassay dish. Colonies are harvested from the bioassay dish after overnight incubation. F: A 15% glycerol stock is made from a portion of the harvested colonies. G: A portion of the harvested cells is superinfected with helper phage. H: Rescued phage are PEG precipitated, resuspended, and used for another round of panning to enrich for high-affinity binders.

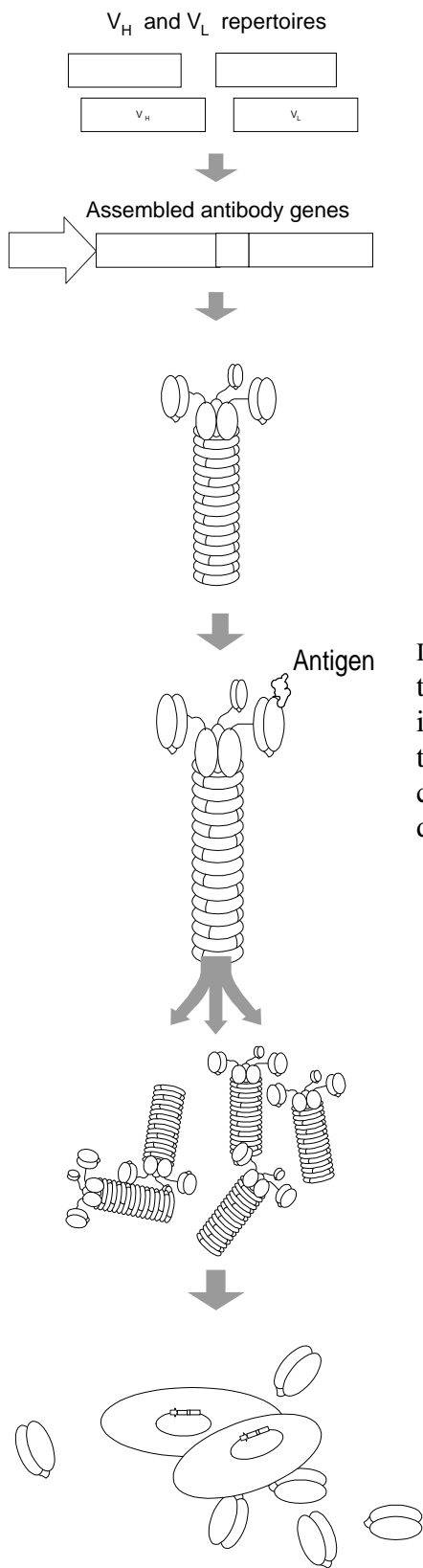


**Figure 4.** ScFv library construction.  $V_H$  and  $V_L$  genes are harvested from B cells. The genes are then amplified by PCR using sequences on framework regions as priming sites (small arrows). To create the  $V_H$  repertoire, altered CDR3s are combined with PCR-amplified CDR1,2s resulting in the assembly of complete  $V_H$  genes.  $V_H$  and  $V_L$  genes are separated by a short linker sequence in the recipient phage vector. A single promoter drives the expression of the scFv/pIII coat fusion gene. A representation of recombinant phage is shown on the right. A:  $V_H$ , B:  $V_L$ , C: linker, D: pIII phage coat, E: pVIII phage coat.



**Figure 5.** Fab library construction.  $V_H$  and  $V_L$  repertoires are created as in Fig. 4.  $V_H$  and  $V_L$  genes are driven by separate promoters in the phage plasmid. Both are fused to a secretory signal (depicted as an empty box between the promoter and the antibody gene), but only Fd ( $V_H$  + constant domain of the heavy chain) is fused to the pIII phage coat gene. Expression in *E. coli* results in the assembly of Fab in the periplasmic space. A representation of recombinant phage is shown on the right. A: $V_L$ , B: $V_H$ , D:pIII phage coat, E:pVIII phage coat.



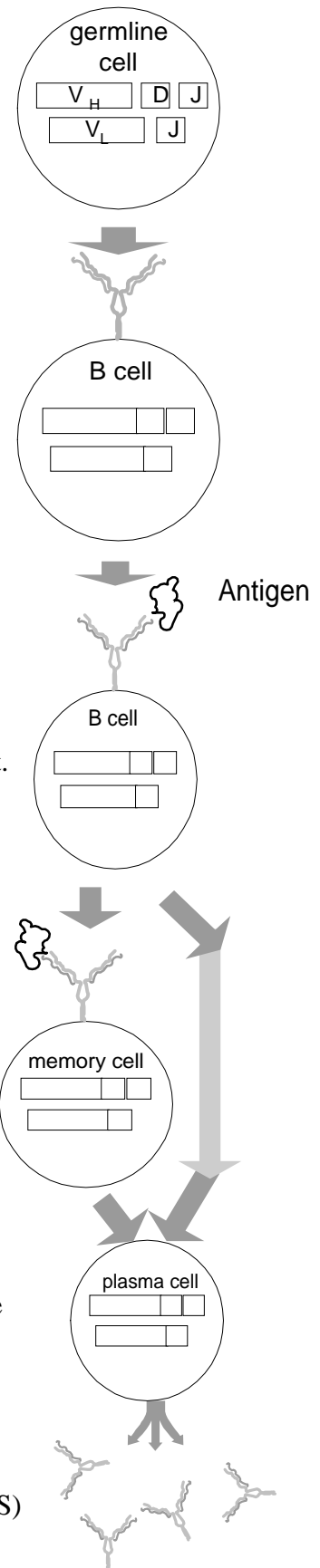


I. IS: Rearrangement of germline V-genes by translocation, PD: pooled V-genes are assembled combinatorially by PCR and subcloned into phage vector  
 II. IS: B cells harboring rearranged V-genes display the antibody on their surface, PD: filamentous phage particles display the antibody as a coat protein fusion

III. B cells or phage particles harboring antibodies that bind antigen are selected to proliferate. In the immune system, the B cells differentiate into two types of cell populations: the short-lived plasma cells and the long-lived memory cells that readily differentiate into plasma cells upon antigen contact.

IV. IS: Soluble antibodies are produced by the plasma cell, PD: soluble antibodies are produced by using a suitable *E. coli* host (i.e. the antibody fragments are not expressed as phage coat protein fusions, but distinct soluble entities that bind antigen).

**Figure 6.** Comparison of phage display (PD) antibody selection (left) with immune system (IS) strategy (right).



<b>Table 1. Antibodies isolated from phage display libraries.</b>		
<b>Antigen/Hapten</b>	<b>Antigen Source</b>	<b>Authors</b>
• hepatitis B viral surface protein	vaccine	Zebedee et al. 1992
• phOx (2-phenyl-5-oxazolone)	(synthesized)	Hoogenboom and Winter 1992
• thyroglobulin	human	Nissim et al.1994
• FITC (fluorescein isothiocyanate)	(synthesized)	ibid.
• Streptavidin	<i>Streptomyces avidinii</i>	ibid.
• cytochrome C	horse	ibid.
• CMV (cucumber mosaic virus)	infected plant sap	Zeigler et al. 1995
• VIP (vasoactive intestinal peptide) - implicated in gastrointestinal relaxation	human	Tyutyulkova et al. 1996
• Le <sup>x</sup> (3-fucosyllactosamine) - carbohydrate determinant on epithelial tumors and myleoid cells	(synthesized)	Dinh et al. 1996
• RGII (rhamnogalacturonan) - pectic polysaccharide in the primary cell wall of higher plants	sycamore	Williams et al. 1996
• estradiol	human	Vaughan et al.1996
• MSPI (merozoite surface protein) - an antigenic determinant on the red blood cell-invasive merozoite	<i>Plasmodium falciparum</i> (malaria)	ibid.
• VLDLR (very low density lipoprotein receptor)	chicken	ibid.
• Potato leafroll luteovirus	Infected plant sap	Harper et al. 1997
• Melanoma cells	human	Kupsch et al. 1999
• Crotoxin (snake venom component)	Rattle snake	Cardoso et al. 2000
• CDC2a cell cycle protein	<i>Arabidopsis</i>	Eeckhout et al. 2000

## Chapter 2

### Immunomodulation of Flavonoid Biosynthesis in Transgenic *Arabidopsis*

In an effort to test the feasibility of intracellular expression of enzyme-targeted antibodies to alter metabolism, recombinant antibody fragments in the single-chain format (scFv) were isolated from a phage display library using *Arabidopsis* chalcone isomerase (CHI) of the flavonoid biosynthetic pathway as the antigen. Each of the genes encoding the scFv's was cloned into a plant transformation vector, which was subsequently used to generate transgenic plants. One transgenic line with low expression of one of the scFv's appeared to have an altered flavonoid metabolism, as evidenced by a reduced capacity for anthocyanin accumulation and a reduction in flavonol glycosides in seedlings. Strong corroborating evidence that implicated the binding of scFv to CHI in the phenotypic alterations was obtained from protein mobility shift assays. Taken together, the results indicate that scFv-mediated metabolic alteration is possible in plants. Thus, we show that intracellular expression of scFv's can be exploited as an additional tool for metabolic engineering.

*Manuscript to be submitted.*

## Introduction

Flavonoids are secondary metabolites that have been implicated in numerous essential plant functions including protection from UV radiation (Landry et al. 1995), defense against herbivory and pathogen invasion (Arimura et al. 2000; Christensen et al. 1998; Junghanns et al. 1998), induction of genes of symbiotic *Rhizobia* for root nodule formation in leguminous species (Recourt et al. 1991; Recourt et al. 1992), and male fertility in some plants (van der Meer et al. 1992). In addition, these compounds function in plant pigmentation, thus making genetic analysis of mutants for various steps of the flavonoid biosynthetic pathway relatively straightforward. Identification and scoring of mutants is done on the basis of effects on flower, seed, or even hypocotyl color, depending on the plant species being analyzed. In *Arabidopsis*, a series of structural mutants, each of which is defective or deficient for a key enzyme in flavonoid biosynthesis, has been established (Shirley et al. 1995). In addition, numerous lines with defective flavonoid regulatory genes, some of which having concomitant effects on trichome development, have also been identified (reviewed in Winkel-Shirley 2001). Because the mutations in these plants result in reduced pigmentation of the seed coat, or *testa*, the mutants have collectively been named *transparent testa* (*tt*). Currently, eight structural and at least six regulatory genes affecting flavonoid biosynthesis in *Arabidopsis* have been cloned (reviewed in Winkel-Shirley 2001). Being relatively well-defined, the pathway is an attractive target for metabolic engineering efforts, which in our case, is the study of the feasibility of expressing enzyme-targeted antibodies in the plant cytosol as a means of regulating flavonoid metabolism at a specific step.

In the phage display technique for isolating antibodies, recombinant antibodies are typically expressed in a single-chain fragment format (“scFv”) in which the  $V_H$  and the  $V_L$  regions are joined by a short linker sequence (Hoogenboom and Winter 1992). In addition, the scFv molecule is commonly expressed as a fusion partner of the pIII coat protein of M13 filamentous phage in a configuration that allows *in vitro* screening of diverse repertoires of phage-scFv particles for binders to target antigens. Each unique phage particle displays only the scFv encoded by the phagemid (circular viral DNA) it encapsidates. Therefore, each phage-scFv is functionally monoclonal with a unique binding specificity. A key advantage of this technique over conventional methods is that the isolation of antibodies, albeit in a different format, is done without performing immunizations. The time required for antibody isolation is also generally shorter because, unlike methods for generating monoclonal antibodies using the hybridoma technique, the phage display strategy is not constrained by variabilities in sensitivity and activity of an individual organism’s immune system. Among other benefits is the larger antibody repertoire, including molecules with completely novel binding motifs that natural immune systems fail to generate. Also, since each phage encapsidates a unique gene encoding the scFv-pIII fusion, subsequent cloning of scFv genes is straightforward.

With the initial demonstration that functional antibodies could be expressed in plants (Hiatt et al. 1989), subsequent attempts at expressing “plantibody” genes have been carried out with a variety of targets. For instance, anti-phytochrome antibodies in the scFv format have been successfully expressed in tobacco, which resulted in aberrant phytochrome-dependent germination of transgenic seeds (Owen et al. 1992). As a possible crop-protection strategy, scFv’s against virus particles have also been expressed

in plants, resulting in the successful arrest of systemic invasion (Tavladoraki et al. 1993). More recently, it had been shown that scFv's could be used as immunomodulators, specifically binding abscissic acid (ABA) to alter ABA-dependent developmental programs and physiological functions (Artsaenko et al. 1995; Conrad and Fiedler 1998; Phillips et al. 1997). New plantibody expression experiments include a growing list of antibody targets such as herbicides (Longstaff et al. 1998), mycotoxins (Yuan et al. 2000), and other invasive plant pathogens (Franconi et al. 1999; Harper et al. 1999). Because we are primarily interested in enzyme-targeted antibody expression, we were particularly intrigued by the earlier reports demonstrating successful targeting of intracellular components. From these, we inferred that the scFv format was ideal for expressing antibodies that would recognize metabolic systems *in planta*, because in such a format the inherent requirement for disulfide bond formation in naturally-occurring immunoglobulins, and by extension, the requirement for a non-reducing environment for proper assembly, could both be bypassed (De Jaeger et al. 2000; Tavladoraki et al. 1999). For our study, we isolated and cloned scFv's against the chalcone isomerase (CHI) enzyme of *Arabidopsis thaliana*, and subsequently mobilized the genes into plants for expression under the control of a strong constitutive promoter. CHI is the second enzyme of the flavonoid biosynthetic pathway. It catalyzes the cyclization of the three-carbon chain that tethers the two benzene rings of the polyphenolic compound, naringenin chalcone, to create naringenin, an early precursor of several classes of pathway end-products that include proanthocyanidins, anthocyanins, and flavonols (Swain 1976; Koes et al. 1994). Here, we present the first evidence that phage-derived scFv's can be used

for the immunomodulation of plant metabolism by binding a key enzyme of the targeted pathway in transgenic plants.

## Materials and Methods

### *Phage Display Library Screening*

ScFv's against CHI were isolated using a modified version of the protocol supplied with the synthetic scFv library from the Winter laboratory, MRC, Cambridge (Nissim et al. 1994). Two independent series of library screenings were performed. In one series, thioredoxin-CHI (TRX-CHI) (Pelletier et al. 1999) was used as the antigen, while in another series, glutathione-S-transferase-CHI (GST-CHI) (Cain et al. 1997) was used. For all rounds of screening, immunotubes (Nunc Maxisorp, Gibco BRL) were coated with the antigen by overnight incubation at room temperature with a solution of 10 µg/ml of the fusion protein in phosphate-buffered saline (PBS). The following day, the tubes were washed three times with PBS and subsequently blocked with 2% milk-PBS (MPBS) for 2 h at 37°C. The tubes were washed again as above. Two ml of phage scFv library, containing approximately  $10^{13}$  transforming units, and 2 ml 4% MPBS were added to each tube. The tubes were incubated at room temperature for 30 min with gentle shaking and for an additional 90 min without shaking. The solution was then discarded and the tubes washed 20 times with PBS-T (PBS with 0.1 % Tween -20), then 20 times with PBS. Bound phage particles were eluted from the tubes by incubating with 1 ml freshly-prepared 100 mM triethanolamine for 10 min with gentle shaking. The resulting eluates were then quickly neutralized by transferring to microfuge tubes containing 0.5 ml 1 M Tris, pH 7.4. To amplify the eluted phage particles, 9 ml of an

exponentially-growing *E. coli* TG-1 culture ( $OD_{600} = 0.6$ ) was infected with 1 ml of the phage solution. Infection was carried out for 30 min at 37°C without shaking. To estimate the titre, 100 µl of the infected culture was used to make five 100-fold serial dilutions in 2XTY (16 g/L tryptone, 10 g/L yeast extract, 5 g/L NaCl), which were plated on TYE medium (10 g/L tryptone, 5 g/L yeast extract, 8 g/L NaCl, 15 g/L Gibco Bacto-Agar) containing 100 mg/L ampicillin and 1% glucose. The remainder of the culture was spun at 3,300 x g and resuspended in 1 ml 2XTY liquid medium, then plated on TYE medium, with ampicillin and glucose at the abovementioned concentrations, in a 12' x 12' Nunc Bio-Assay dish. Plates containing the serial dilutions were incubated at 37°C overnight which resulted in readily-identifiable colonies the following day. The bio-assay dish was incubated at 30°C overnight for slower growth in order to minimize under-representation of phage-scFv's that confer a selective disadvantage to the *E. coli* host cells. The next day, the bacterial colonies that developed on the large dish were resuspended in 1 ml 2XTY. Fifty microliters of the suspension was used to inoculate 50 ml fresh 2XTY containing 100 mg/L ampicillin and 1% glucose. The new culture was then grown to an  $OD_{600}$  of 0.6, at which point 10 ml of the culture was infected with helper phage M13KO7 (Stratagene) at a ratio of 20 helper phage per bacterial cell. The infection process was again performed at 37°C for 30 min without shaking. The cells were then harvested by centrifugation at 3,300 x g for 10 min. The resulting pellet was used to inoculate 300 ml 2XTY with 100 mg/L ampicillin and 25 mg/L kanamycin (M13KO7 confers kanamycin resistance), and the culture incubated at 30°C. The following day, the culture was centrifuged at 10,800 x g and the supernate was transferred to a new container. To the supernate, 0.2 vol of polyethylene glycol-NaCl



(20% PEG 6000, 2.5 M NaCl) was added. The mixture was incubated on ice for 1 h, then centrifuged at 10,800 x g for 30 min. The phage pellet was washed with a mixture of 40 ml ddH<sub>2</sub>O and 8 ml PEG-NaCl, spun at 3,300 x g for 30 min, then resuspended in 2 ml PBS. This suspension was used to start another round of “panning” to enrich for high-affinity binders to CHI.

#### *ELISA Screening of Colonies for Production of scFv's that Recognize CHI*

Colonies picked at random from the serial dilution plates were grown in individual wells of a sterile 96-well ELISA plate containing 100 µl 2XTY with 100 mg/L ampicillin and 1 % glucose per well at 37°C. The next day, 10<sup>9</sup> pfu M13KO7 helper phage was added to each well. The plate was incubated at 37°C for 30 min without shaking, then for 1 h at the same temperature with shaking. The cells were pelleted by centrifugation at 1,800 x g for 10 min, then resuspended with 200 µl 2XTY containing 100 mg/L ampicillin and 25 mg/L kanamycin. The plate was incubated at 30°C overnight with shaking.

Fifty microliters of supernate from each well was added to the wells of another ELISA plate that had been pre-coated overnight at room temperature with TRX-CHI (Pelletier et al. 1999) at 10 µg/ml PBS. The plate was incubated for 90 min at room temperature and then washed three times with PBS-T and three times with PBS. Rabbit-anti-M13 IgG (Sigma Chemicals) was diluted 1:8000 in 2% MPBS and 100 µl was added to each well. Incubation and washes were performed as in the previous step. The secondary antibody, goat-anti-rabbit IgG conjugated with horseradish peroxidase (HRP), was diluted 1:5000 and 100 µl added to each well. Incubation and subsequent washes

were performed as above. To each well was then added 100  $\mu$ l of freshly-prepared substrate solution containing 100  $\mu$ g/ml 3,3',5,5'-tetramethylbenzidine and 0.2  $\mu$ l/ml 30% H<sub>2</sub>O<sub>2</sub> in 100 mM sodium acetate, pH 6. The plate was incubated at room temperature for 10 min, and the reactions subsequently stopped with the addition of 50  $\mu$ l of 1 M H<sub>2</sub>SO<sub>4</sub>/well. Absorption at 450 nm was measured using a microplate reader (MRX, Dynatech Laboratories).

### *Plant Transformation Constructs*

The scFv genes used in this study were comprised of V<sub>H</sub> and V<sub>L</sub> sequences cloned from human B cells, and a c-myc tag downstream from V<sub>L</sub> (Hoogenboom and Winter 1992; Nissim et al. 1994). The tag facilitates the detection of expressed scFv proteins in transgenic plants. The cloning strategy for the insertion of the scFv genes into a plant transformation vector is outlined in Fig. 1. The scFv genes were first amplified from the pHEN phagemid (Hoogenboom and Winter 1992), using primers modified from previously-described primer sets (Marks et al. 1991): primer 1: 5' CAG CCA TGG CCC AGG T(A/C/G)C AG, primer 2: 5' GGC GAG CTC TCA CTA TGC GGC CCC. These primers had been configured to include an *Nco*I site and a *Sac*I site, respectively, and short 5' sequences to facilitate subsequent digestion of the PCR product. Each PCR reaction contained 1.25 units of *Pfu* polymerase (Stratagene), 0.5  $\mu$ M of each primer, 0.2 mM dNTP, 5  $\mu$ l of the manufacturer-supplied buffer concentrate, and 1 ng of template DNA, in a final volume of 50  $\mu$ l. The reactions were performed as follows: 45 sec of T<sub>melt</sub>=94°C followed by 35 cycles of T<sub>melt</sub>=94°C (45 sec), T<sub>anneal</sub>=50°C (45 sec), T<sub>extension</sub>=72°C (60 sec). A 10 min extension at 72°C was performed as a final step. The

PCR product was subsequently digested with 10 units of *NcoI* and 10 units of *SacI* to release the short linker sequence flanking the amplification products. Concurrently, 5 µg of the cloning vector, pRTL2 (Carrington and Freed 1990), which features a double-enhanced 35S cauliflower mosaic virus (CaMV) promoter and a translational enhancer from tobacco etch virus (TEV), was digested with the same quantities of *NcoI* and *SacI* overnight. The digested PCR product was purified using Qiaquick PCR clean-up columns (Qiagen). The digested vector was fractionated on a low-melt agarose gel to separate the linearized vector from the short cloning site sequence released by the *NcoI/SacI* treatment. The vector band was subsequently excised from the gel and purified using a Qiaquick gel clean-up column (Qiagen). To estimate DNA yield, gel electrophoresis was performed on a fraction of the purified vector and PCR product, together with a known amount of *HindIII*-digested λ phage DNA standard. Ligation was performed overnight at 16°C using 0.2 pmol of vector, approximately 1 pmol of insert, 3 units of T4 ligase (Promega), and 1 µl of manufacturer-supplied buffer concentrate, in a final volume of 10 µl. The ligation reaction was heated for 15 min to minimize arcing during the subsequent electroporation. One µl of the ligation mixture was used to transform 40 µl of electrocompetent-DH10B *E. coli* cells (Dower et al. 1988).

Transformed cells were recovered on LB medium with ampicillin at 100 mg/L. Plasmids were isolated using the miniprep method of Birnboim and Doly (1979). The expression cassette was excised from the recombinant pRTL2 using *HindIII* and *SacI* and subcloned into the corresponding sites of pBI121 using the same DNA digestion and ligation protocols described above, except that the restriction enzyme reactions were extracted with phenol as described in Sambrook et al. (1989) prior to fractionation on the low-melt

gel. The recombinant pBI121 plasmids were recovered from DH10B using the same miniprep procedure, then mobilized into *Agrobacterium* strain GV3101 using a freeze-thaw protocol (Chen et al. 1994). These strains were used for subsequent transformation of *Arabidopsis* as described below. To sequence the scFv genes subcloned into the pBI121 plasmids, the transformed *Agrobacterium* strains were grown in 5 ml 2XTY medium containing 34 mg/L rifampicin, 25 mg/L gentamicin, and 50 mg/L kanamycin at 28°C overnight to produce microgram quantities of plasmids, which were recovered using the abovementioned miniprep protocol. For cycle sequencing, each reaction contained 3.2 pmol of either primer 1 or 2, 8 µl of Big Dye-Terminator (Perkin Elmer) ready-mix solution, and approximately 200 ng of plasmid DNA, in a final volume of 20 µl. The reactions were cycled as follows: 30 sec of  $T_{\text{melt}}=94^{\circ}\text{C}$  followed by 25 cycles of  $T_{\text{melt}}=94^{\circ}\text{C}$  (30 sec),  $T_{\text{anneal}}=50^{\circ}\text{C}$  (15 sec),  $T_{\text{extension}}=60^{\circ}\text{C}$  (4 min). The sequencing reactions were then submitted to the Virginia Tech DNA Sequencing Facility for further processing. Sequence analyses and alignment were performed using the Lasergene suite of DNA analysis programs (DNA Star).

### *Plant Transformation*

Plants were grown in preparation for transformation as follows: approximately 10 mg of wild-type Columbia seeds were scattered on a 70 mm no.5 Whatman filter paper disk pre-moistened with Murashige-Skoog (MS) medium in a plastic Petri dish. The plate was sealed with parafilm, wrapped in aluminum foil, and placed at 4°C for 2 d for vernalization. The seeds were then resuspended in 2 ml of 0.05% agarose solution and dispensed evenly among 6 small pots (3.25 X 2.25 inches). For the first 2 weeks, the

seedlings were grown under 8 h days at 150  $\mu$ E of white light, 22°C. The plants were then switched to 16 h days at 120  $\mu$ E, 22°C to induce bolting. The following week, the plants were thinned to 20 individuals per pot. Typically, the first bolts appeared in 35-40 d after planting on soil. These were allowed to develop for 5 d after emergence, then clipped to encourage the development of multiple secondary bolts. Six days after clipping, the plants were placed in a pan of water overnight. The next day, siliques, flowers, and partially-opened buds were removed just prior to vacuum infiltration of the remaining closed buds with *Agrobacterium*.

Transformation by vacuum infiltration was performed using a procedure based on the method of Bechtold et al. (1993). *Agrobacterium* strains containing the scFv constructs in pBI121 were grown in 25 ml 2XTY with 34 mg/L rifampicin, 25 mg/L gentamycin, and 50 mg/L kanamycin for two days at 28°C with vigorous shaking. To the stationary-phase culture was added 400 ml fresh 2XTY with antibiotics and incubation was continued under the same conditions. After about 16 h, the cells were pelleted by centrifugation at 5,000 RPM for 10 min and then resuspended in approximately 500 ml of infiltration medium (0.5X MS salts, 1X B5 vitamin solution, 5% sucrose, 0.044  $\mu$ M benzylaminopurine, 0.03% Silwet-77 (Lehle Seeds); 500X B5 vitamin stock solution, values in % w/v: 0.5% thiamine-HCl, 0.05% nicotinic acid, 0.05% pyridoxine-HCl, 5% myoinositol) to an OD<sub>600</sub> of 0.8. The solution was poured into a plastic dish on which the plants had been placed in an inverted position, with inflorescences splayed on the dish surface. In most cases, the inverted pots were suspended above the dish surface using tube caps as supports to keep leaves out of the infiltration medium. Vacuum was then applied at 15 in Hg using a vacuum oven (Precision Oven, GCA Corporation). After 15

min, the vacuum was rapidly released. The plants were then allowed to recover overnight in a darkened growth chamber. The following day, a 16 h day cycle was resumed. Seeds were harvested as soon as siliques turned light brown or started opening, approximately 2-3 weeks after infiltration. These T<sub>1</sub> seeds were surface-sterilized as previously described (Kubasek et al. 1992), scattered on sterile, MS-moistened Whatman filter paper disks at a density of roughly 300 per filter, vernalized as described above, and placed in a 22°C incubator under continuous white light (150 µE). Each filter was then placed on MS-agar plates containing 50 mg/L kanamycin and 200 mg/L timentin. T<sub>1</sub> transformants were identified based on survival after 12 days under kanamycin selection, and were subsequently subjected to segregation analysis on MS-agar plates with antibiotics until putative homozygous T<sub>4</sub> lines were established.

#### *Growth of Seedlings for HPLC and Immunoblot Assays*

Seeds were sterilized as described previously (Kubasek et al. 1992), and plated on MS-agar medium containing 2% sucrose, but no antibiotics. Plates were sealed with parafilm, wrapped in aluminum foil, and stored at 4°C for 2 d for vernalization. The plates were subsequently transferred into a 22°C incubator under continuous white light (150 µE). For HPLC analysis, 30 seedlings were harvested on the third, fifth, and seventh day of exposure. For immunoblot analysis, approximately 300 mg (wet weight) of seedlings were harvested on the fifth day.

### *HPLC Analysis of Flavonoid Content*

Methanolic extracts of 3, 5, and 7 day-old seedlings were prepared and analyzed by HPLC as described by Saslowsky et al. (2000).

### *Protein Extraction for Immunoblot Assays*

Extraction of protein for analysis by SDS-PAGE was performed as described by Cain et al. (1997), except that the extraction buffer included proteinase inhibitors (Proteinase Inhibitor Cocktail, Boehringer Mannheim). One tablet of the proteinase inhibitor mix was dissolved in 10 ml of extraction buffer as recommended by the manufacturer. For analysis by non-denaturing PAGE, protein was extracted in 0.1 M Na-PO<sub>4</sub> pH 7 buffer [61.5% (v/v) 0.1M K<sub>2</sub>HPO<sub>4</sub>, 38.5% (v/v) 0.1M KH<sub>2</sub>PO<sub>4</sub>] containing the same proteinase inhibitor cocktail. For both types of extractions, plant tissue was frozen in liquid N<sub>2</sub>, ground to a fine powder using a pre-chilled mortar and pestle, immediately weighed, and then macerated further in extraction buffer at 500 µl per gm of tissue. The extract was incubated on ice for 1 h. The soluble proteins were separated by centrifugation at 16,000 x g for 15 min at 4°C. Bradford assays were then performed to quantify total soluble protein (TSP). For estimating the amount of scFv in each protein extract, the concentration of scFv in the lysate of one transgenic line was established to serve as the standard with which lysates from other transgenic lines would be compared. Five micrograms each of B7a-3 and wild-type lysate, and a dilution series of bovine serum albumin (BSA, Sigma Chemicals) ranging from 62.5 ng to 500 ng, were fractionated by 10% SDS-PAGE on a Miniprotean II System (Biorad). The gel was subsequently stained with Coomassie dye to visualize the proteins. When the stained gel

was subjected to a densitometric analysis program, ImageQuant v.1.2 (Molecular Dynamics), the signal from each band was assigned a relative intensity value (RIV). By plotting concentrations of the samples in the BSA dilution series against the corresponding RIV, a linear curve was obtained, which was used to determine the concentration corresponding to the corrected (i.e. background signal subtracted) RIV for the scFv in B7a-3.

#### *Immunoblot Analysis of scFv and Flavonoid Enzyme Levels*

Plant or bacterial proteins extracted under denaturing conditions were fractionated by 10% SDS-PAGE on a Miniprotean II System and transferred to 0.2 µm nitrocellulose filters (Biorad) as described previously (Cain et al. 1997). For detection of CHI with scFv-expressing particles, membranes were incubated with  $10^7$  phage particles/ml in 2% MPBS at 4°C overnight. The succeeding steps were performed as described previously (Cain et al. 1997), using a rabbit-anti-M13 IgG secondary antibody (Sigma Chemicals), diluted 1:5000 in 2% MPBS, followed by an HRP-conjugated goat-anti-rabbit tertiary antibody (Jackson Immunoresearch) diluted 1:5000 in 2% MPBS. Immunoblot analysis using IgG or IgY antibodies was as described previously (Cain et al. 1997), using the following antibody dilutions: polyclonal chicken-anti-CHI (Cain et al. 1997), 1:500; affinity-purified chicken-anti-CHI (Saslowsky and Winkel-Shirley, *in press*), 1:1000; affinity-purified polyclonal rabbit-anti-CHS (Saslowsky and Winkel-Shirley, *in press*), 1:2000; mouse monoclonal 9E10-anti-c-myc (Sigma Chemicals), 1:1000; HRP-conjugated rabbit-anti-chicken, HRP-conjugated goat-anti-rabbit, HRP-conjugated goat-anti-mouse (all from Jackson Immunoresearch), 1:75000. HRP activity was detected



using the West Dura Detection System (Pierce Chemicals) according to manufacturer's instructions.

Protein extracts prepared under non-denaturing conditions were mixed with an equal volume of 2X sample buffer (125 mM Tris-HCl, pH 6.8, 20% glycerol, 0.05% bromophenol blue), and were subsequently fractionated by 10% PAGE using non-denaturing tank buffer (25 mM Tris, pH 8.3, 192 mM glycine). Proteins were transferred to 0.2  $\mu$ m nitrocellulose by electroblotting at 60 volts for 45 min, and then at 100 volts for 60 min. The membranes were blocked with 5% MPBS-T at room temperature for 1 h, and then probed overnight at 4°C with affinity-purified rabbit-anti-CHS (1:2000), affinity-purified chicken-anti-CHI (1:1000), or mouse monoclonal 9E10-anti-c-myc (1:1000). Succeeding steps were done as described for immunoblots of denatured proteins.

#### *DNA Isolation and Southern Blot Analysis*

Plant genomic DNA was isolated and subjected to Southern blot analysis as previously described (Saslowky et al. 2000), but using a probe specific to either the NPTII gene downstream from the T-DNA right border or to *Arabidopsis* CHI. Both probes were generated by PCR using the DIG DNA Labeling and Detection Kit (Boehringer Mannheim). The CHI probe was synthesized as previously described (Saslowky et al. 2000). The NPTII probe was synthesized using the primers, 5'GAA CAA GAT GGA TTG CAC GC and 5'AAG AAG GCG ATA GAA GGC GAT. One nanogram of pBI121 plasmid was used as template in a 100  $\mu$ l reaction containing 2.5  $\mu$ M of each primer, 0.2 mM dATP, 0.2 mM dGTP, 0.2 mM dCTP, 0.19 mM dTTP, and

0.01 mM DIG-labeled dUTP, 1.5 mM MgCl<sub>2</sub>, 1X concentrated polymerase buffer, and 2.5 units of Taq DNA polymerase. The PCR reaction was performed as follows: 45 sec of T<sub>melt</sub>=94°C followed by 35 cycles of T<sub>melt</sub>=94°C (45 sec), T<sub>anneal</sub>=50°C (45 sec), T<sub>extension</sub>=72°C (60 sec). A 10 min extension at 72°C was performed as a final step. The PCR products were separated from unincorporated nucleotides using Qiaquick PCR clean-up columns.

### *Naming System*

Each scFv sequence and the corresponding recombinant phage clone identified through the ELISA screening process discussed previously were named after the ELISA plate grid address of the infected *E. coli* TG-1 culture that produced the phage. In one case, two phage clones isolated from different ELISA screenings were found to carry the same scFv sequence (B7). To simplify naming, both clones were labeled with the ELISA plate-derived name of the last of the two clones to be isolated. Each clone, however, was designated with the letter “a” or “b” to indicate whether it is the first or the second isolate, respectively (B7a or B7b). Each putatively homozygous population of transgenic plants generated from a unique transformation event was labeled with the name of the scFv gene it contains followed by a number that identifies the population as a unique transgenic line.

### Results

The goal of the current project was to determine the feasibility of *in planta* expression of antibodies in the scFv format to modulate plant metabolism. For this

purpose, the Nissim phage display antibody library was screened to isolate scFv's that bind CHI. Three rounds of library screening were performed using CHI fused to either thioredoxin (TRX) or glutathione-S-transferase (GST) as antigen. Six phage clones were isolated, which were named A5, B7a/b, D10, E7, F11, and H5. Of these, A5 and B7a/b were isolated using GST-CHI as the antigen in the phage display library panning process. The rest were isolated using TRX-CHI. Immunoblot analysis using the phage particles as antibody probes was used to confirm the binding specificity of the scFv's. Differences in reactivities against recombinant TRX and TRX-CHI proteins were observed among the six phage isolates in this experiment (Fig. 2). Four of the six isolates, A5, D10, F11, and H5 cross-reacted with the TRX fusion partner. However, two of the clones, B7b and E7, appeared to bind specifically to CHI. Very noticeably, the bacterial proteins that routinely co-purified with TRX and TRX-CHI were not detected by any of the phage-scFv isolates, but were strongly detected by an anti-CHI polyclonal antibody preparation developed in chicken. This demonstrates the strong specificity of all the phage-scFv's for the target antigen.

Genes for four of the anti-CHI phage isolates, A5, B7a/b, D10, and E7, were successfully amplified from the phage by PCR using modifications of previously-published primers that flank scFv genes in the pHEN phagemid (Marks et al., 1991; Hoogenboom and Winter, 1992). Cycle sequencing was performed to determine the diversity of these CHI-binders at both the DNA and protein levels (Fig. 3). As expected, the diversity was localized in the V<sub>H</sub> gene, with pronounced differences in the complementarity determining regions (CDR). One scFv sequence, A5, contained an

amber codon in the V<sub>H</sub> region that is recognized as glutamate in *supE* bacteria such as *E. coli* TG-1, but would be read as a stop codon in plants.

All four scFv genes, of which A5 and D10 served as two different negative controls, were cloned into pBI121 *Agrobacterium* vector using a two-step cloning process (Fig. 1). To facilitate cloning, the primers were designed to introduce an *NcoI* site upstream of the V<sub>H</sub> region and a *SacI* site downstream from the scFv c-myc tag. Each gene was subcloned into the pRTL2 vector, adjacent to the strong constitutive plant promoter, the double-enhanced 35S CaMV promoter, and a translational enhancer from tobacco etch virus (TEV) (Carrington and Freed 1990). The expression cassette was then excised from pRTL2 and cloned into the binary vector, pBI121. Using the freeze-thaw transformation procedure, this construct was then moved into the *Agrobacterium* host strain, GV3101, for use in plant transformation.

Transgenic *Arabidopsis* plants (ecotype Columbia) were produced for each scFv construct. A minimum of 10 independent transformed lines was initially identified for each construct by selection on kanamycin. Putative homozygotes were identified for each line based on 100% survival on kanamycin in the T<sub>4</sub> generation. Expression of the scFv's in the transgenic plants was examined by immunoblot analyses using a monoclonal antibody that recognizes the c-myc tag at the carboxy terminus of each scFv (Fig. 4). The approximate amount of scFv in the TSP fraction of a high-level scFv-expressor, B7a-3, was determined by comparing the signal intensity of the scFv band in 5 µg of lysate with the signal intensities of bands in a BSA dilution series on a Coomassie-stained SDS-PAGE (data not shown). The intensities were quantified by densitometry and used to determine that 5 µg of B7a-3 lysate contained 100 ng of scFv (i.e. 2% of

TSP). This sample was then used as a standard for the quantitation of scFv levels in other transgenic lines. Using densitometric analysis, a linear curve was obtained from the dilution series of B7a-3 lysate. The scFv levels in the other transgenic lines were determined to range from a low of <0.1% of TSP for B7b-1 to a high of almost 4% of TSP for B7a-2 (Table 1).

To determine whether expression of the scFv's affected flavonoid biosynthesis in the transgenic plants, the total flavonoid content of developing seedlings was analyzed. The results for three representative independently-transformed lines that show various expression levels of the same scFv gene are shown in Fig. 5. In this assay, methanolic extracts were prepared from equivalent numbers of seedlings at days 3, 5, and 7 of development and subjected to HPLC analysis. As expected, no difference in accumulation of flavonoids was observed for any of the lines expressing A5 or D10. Lines expressing E7 also did not exhibit any difference from wild type. However, one of the B7 lines, B7b-1 showed a consistent reduction of the three flavonoid peaks, glycosylated quercetin and kaempferol (previously identified in Graham 1998; Pelletier et al. 1999; Veit and Pauli 1999). Interestingly, B7b-1 had the lowest detectable scFv level at 0.07% of TSP (Table 1). The other transgenics accumulated scFv protein at levels of up to 4% of TSP, and yet did not show reproducible phenotypic changes. It is formally possible that the *Agrobacterium*-mediated scFv transgene integration into the plant chromosome disrupted a gene that affects CHS or CHI expression, leading to an alteration of flavonoid composition in B7b-1. Another possibility is that the binding of the scFv could destabilize CHI, resulting in lower steady state levels of the enzyme. However, both possibilities are ruled out because the expression levels of CHS and CHI

among all the transgenic plants analyzed did not differ from wild-type levels (Fig. 4). The altered flavonoid accumulation pattern in B7b-1 was also apparent in the reduced pigmentation in the hypocotyls of 5-day-old seedlings grown in the presence of sucrose (Fig. 6). Although not as dramatic as the complete lack of flavonoid pigments in the CHI null mutant, *tt5*, B7b-1 accumulated visibly less pigments than wild-type or B7b-2 seedlings. *Arabidopsis* flavonoid mutants have yellow or pale-brown seeds instead of dark brown because of reduced flavonoid pigments in the seed coat. Such a change in seed color, however, was not perceptible in B7b-1 or in any of the other transgenic lines (data not shown). One possibility is that the scFv-mediated down-regulation of CHI in B7b-1 can be sufficiently compensated for by the accumulation of flavonoid pigments over time and/or developmental induction of flavonoid metabolism, which could result in wild-type appearance of mature plants and seeds.

Southern blot analysis was performed to determine whether scFv expression levels were correlated with the number of transgene insertions into the chromosomes of each of the T<sub>4</sub> lines included in the study. Multiple bands were observed for the transgenes in all 3 lines. The same blots probed with the CHI gene exhibited single bands, confirming that the genomic DNA had been fully digested. Whereas the higher-level expressors (B7a-1 and B7b-2) contained 2 to 3 insertions of the scFv gene, the lowest expressor, B7b-1, contained 6 insertions (Fig. 7). It is possible that gene silencing among the transgenes in the B7b-1 line affects the scFv expression level, consistent with previous observations that correlated high gene copy number with low-level transgene expression (Matzke et al. 1999).

To determine whether the scFv was binding to CHI in these lines, protein mobility shift assays were performed using non-denaturing 10% PAGE. Under native conditions, it was expected that CHI mobility would be affected by the presence of interacting antibodies. As shown in Fig. 8, the migration of CHI in the B7b-1 sample was shifted relative to CHI from wild-type and B7b-2. The scFv in the two transgenic lines was also seen to migrate at very different positions. Whereas the scFv from B7b-2 migrated slowly, presumably due in part to charge repulsion (the charge of the scFv is close to neutral in the gel at pH 8) and perhaps also aggregation, the scFv from B7b-1 migrated further into the gel and at the same position where CHI was detected. The loading control, blot A, shows that the migration of CHS extracted from the transgenic plants closely approximates the migration of CHS extracted from the wild-type, suggesting that scFv expression does not impair the mobility of non-target proteins. *In planta*, expression of the scFv is at least 20-fold higher in B7b-2 than in B7b-1. It appears, therefore, that scFv-overexpression (i.e. >0.1% of TSP) does not necessarily result in abundant functional antibodies that successfully recognize and bind their target. On the contrary, in our hands, overexpression resulted in failure to detect CHI-bound scFv's and consequently, failure to generate plants with the desired phenotypic changes. One possibility is that high-level expression results in aggregation, consistent with the observation that the scFv in B7b-2 migrates slowly in the native gel. It is possible that the optimal level for the expression of functional scFv *in planta* is quite low.

## Discussion

In this project, we were able to successfully express recombinant human antibodies in the single-chain format in *Arabidopsis*. Moreover, we were able to demonstrate the binding of the intended target antigen, CHI, in a phenotypically-altered transgenic plant through native protein mobility-shift assays. This suggests that despite the reducing environment of the plant cytosol, the scFv retained the critical binding domain for CHI recognition.

Expression of scFv targeted against specific metabolic enzymes does not necessarily result in a dramatic phenotype, however (Fig. 6). Unlike anti-sense RNA or mutagenesis strategies that are primarily geared for the creation of functional knock-outs, effecting clearly-visible alterations through antibody expression may be confounded by several factors. For one, there are potential non-specific interactions with other proteins within the plant, which could reduce the pool of functional antibodies available for binding the intended target. In this particular project, however, non-specific interactions were unlikely to have occurred as evidenced by the result of the protein mobility shift assay (Fig. 8) and the non-reactivity of the phage clones with *E. coli* proteins (Fig. 2). Second, cross-talk between pathways that diverge from the same early precursors may partially compensate for a perceived decrease in catalytic efficiency of one of the branch pathways. Such compensation can take the form of increased metabolic flux through the affected branch pathway resulting from a compensatory shunting of precursors. The inherent plasticity of plants in reacting to metabolic change should be considered carefully when choosing the morphological parameters to measure the effect of scFv expression. For instance, the expected reduction in pigmentation in transgenic seeds was



almost imperceptible in line B7b-1. Third, expression of antibodies shown to bind the target enzyme under both physiological and non-physiological conditions does not necessarily result in alteration of catalytic efficiency detectable through *in vitro* enzyme assays. It is possible that the scFv's are binding a CHI structural domain and not the catalytic site, resulting in a more subtle phenotypic alteration. Nonetheless, binding of a structural region *in planta* could result in reduced flavonoid levels due to impairment of the ability of CHI to associate with other components of the flavonoid enzyme complex (Winkel-Shirley 1999).

A surprising finding from this study is that high transgene expression levels do not necessarily translate into the desired phenotypic effect. Our cloning strategy was undertaken primarily to ensure the generation of transgenic lines with high scFv expression levels, with the idea that a higher concentration would facilitate CHI targeting. It was therefore an unexpected finding that the line with the lowest detectable level of scFv had a reproducibly altered flavonoid profile (Figs. 4 and 5). It is interesting to note that another group that had tried a similar metabolic engineering attempt using scFv targeted to dihydroflavonol reductase (DFR) in petunia failed to see phenotypic alterations (i.e. flower color) (De Jaeger et al. 1999). In a transient expression assay using tobacco leaves, one cytosolic anti-DFR scFv was shown to behave like a diabody when subjected to immunoblot analysis, migrating to a region corresponding to twice the molecular weight of a single scFv molecule. Together, these observations suggest that an expression level threshold exists for individual scFv's which, when surpassed, establishes a condition favoring the formation of aggregates. It is now apparent that *in vitro* demonstration of antigen binding does not guarantee proper scFv function *in planta*, not

only because of the inherent differences between *in vitro* and physiological conditions affecting antibody-antigen interaction, but also because of unexpected consequences of varying expression levels.

This work establishes the feasibility of expressing enzyme-targeted scFv in plants for altering metabolism. With the current trend of phage display technology becoming increasingly routine, scFv-expression can be included in our molecular tool kit for metabolic engineering efforts. It will be very exciting to see the departure of this work from a simple proof of principle to facilitation of current metabolic problems such as flower color modification, tannin reduction, and rare-compound production (by shutting off a branch pathway to favor another) among others that have immediate practical impact.

## References Cited

- Arimura, G., K. Tashiro, S. Kuhara, T. Nishioka, R. Ozawa and J. Takabayashi (2000).  
“Gene responses in bean leaves induced by herbivory and by herbivore- induced  
volatiles.” Biochem Biophys Res Commun **277**: 305-10.
- Artsaenko, O., M. Peisker, U. zur Nieden, U. Fiedler, E. W. Weiler, K. Muntz and U.  
Conrad (1995). “Expression of a single-chain Fv antibody against abscisic acid  
creates a wilted phenotype in transgenic tobacco.” Plant J **8**: 745-50.
- Bechtold, N., J. Ellis and G. Pelletier (1993). “In planta *Agrobacterium* mediated gene  
transfer by infiltration of adult *Arabidopsis thaliana* plants.” C R Acad Sci Paris  
**316**:1194-1199.
- Birnboim, H. C. and J. Doly (1979). “A rapid alkaline extraction procedure for screening  
recombinant plasmid DNA.” Nucleic Acids Res **7**: 1513-23.
- Cain, C. C., D. E. Saslowsky, R. A. Walker and B. W. Shirley (1997). “Expression of  
chalcone synthase and chalcone isomerase proteins in *Arabidopsis* seedlings.”  
Plant Mol Biol **35**: 377-81.
- Carrington, J. C. and D. D. Freed (1990). “Cap-independent enhancement of translation  
by a plant potyvirus 5' non-translated region.” J Virol **64**:1590-1597.
- Chen, H., R. S. Nelson and J. L. Sherwood (1994). “Enhanced recovery of transformants  
of *Agrobacterium tumefaciens* after freeze-thaw transformation and drug  
selection.” Biotechniques **16**: 664-8, 670.
- Christensen, A. B., P. L. Gregersen, C. E. Olsen and D. B. Collinge (1998). “A flavonoid  
7-O-methyltransferase is expressed in barley leaves in response to pathogen  
attack.” Plant Mol Biol **36**: 219-27.

- Conrad, U. and U. Fiedler (1998). "Compartment-specific accumulation of recombinant immunoglobulins in plant cells: an essential tool for antibody production and immunomodulation of physiological functions and pathogen activity." Plant Mol Biol **38**: 101-9.
- De Jaeger, G., E. Buys, D. Eeckhout, C. De Wilde, A. Jacobs, J. Kapila, G. Angenon, M. Van Montagu, T. Gerats and A. Depicker (1999). "High level accumulation of single-chain variable fragments in the cytosol of transgenic *Petunia hybrida*." Eur J Biochem **259**: 426-34.
- De Jaeger, G., E. Fiers, D. Eeckhout and A. Depicker (2000). "Analysis of the interaction between single-chain variable fragments and their antigen in a reducing intracellular environment using the two- hybrid system." FEBS Lett **467**: 316-20
- Dower, W. J., J. F. Miller and C. W. Ragsdale (1988). "High efficiency transformation of *E. coli* by high voltage electroporation." Nucleic Acids Res **16**: 6127-45.
- Franconi, R., P. Roggero, P. Pirazzi, F. J. Arias, A. Desiderio, O. Bitti, D. Pashkoulov, B. Mattei, L. Bracci, V. Masenga, R. G. Milne and E. Benvenuto (1999). "Functional expression in bacteria and plants of an scFv antibody fragment against tospoviruses." Immunotechnology **4**: 189-201.
- Graham, T. (1998). "Flavonoid and flavonol glycoside metabolism in *Arabidopsis*." Plant Physiol Biochem **36**: 135-144.
- Harper, K., R. L. Toth, M. A. Mayo and L. Torrance (1999). "Properties of a panel of single chain variable fragments against potato leafroll virus obtained from two phage display libraries." J Virol Methods **81**: 159-68.

- Hiatt, A., R. Cafferkey and K. Bowdish (1989). "Production of antibodies in transgenic plants." Nature **342**: 76-8.
- Hoogenboom, H. R. and G. Winter (1992). "By-passing immunisation: Human antibodies from synthetic repertoires of germline VH gene segments rearranged in vitro." J Mol Biol **227**: 381-8.
- Junghanns, K. T., R. E. Kneusel, D. Groger and U. Matern (1998). "Differential regulation and distribution of acridone synthase in *Ruta graveolens*." Phytochemistry **49**: 403-11.
- Koes, R. E., F. Quattrocchio, J. N. M. Mol (1994). "The flavonoid biosynthetic pathway in plants: function and evolution." BioEssays **16**: 123-132.
- Kubasek W. L., B. W. Shirley, A. McKillop, H. M. Goodman, W. Briggs and F. M. Ausubel (1992). "Regulation of flavonoid biosynthetic genes in germinating *Arabidopsis* seedlings." Plant Cell **4**: 1229-1236.
- Landry, L. G., C. C. Chapple and R. L. Last (1995). "*Arabidopsis* mutants lacking phenolic sunscreens exhibit enhanced ultraviolet-B injury and oxidative damage." Plant Physiol **109**: 1159-66.
- Longstaff, M., C. A. Newell, B. Boonstra, G. Strachan, D. Learmonth, W. J. Harris, A. J. Porter and W. D. Hamilton (1998). "Expression and characterisation of single-chain antibody fragments produced in transgenic plants against the organic herbicides atrazine and paraquat." Biochim Biophys Acta **1381**: 147-60.
- Marks, J. D., H. R. Hoogenboom, T. P. Bonnert, J. McCafferty, A. D. Griffiths and G. Winter (1991). "By-passing immunization: human antibodies from V-gene libraries displayed on phage." J Mol Biol **222**: 581-97.

- Matzke, M. A., M. F. Mette, W. Aufsatz, J. Jakowitsch and A. J. Matzke (1999). "Host defenses to parasitic sequences and the evolution of epigenetic control mechanisms." Genetica **107**: 271-87.
- Nissim, A., H. R. Hoogenboom, I. M. Tomlinson, G. Flynn, C. Midgley, D. Lane and G. Winter (1994). "Antibody fragments from a 'single pot' phage display library as immunochemical reagents." Embo J **13**: 692-8.
- Owen, M., A. Gandecha, B. Cockburn and G. Whitelam (1992). "Synthesis of a functional anti-phytochrome single-chain Fv protein in transgenic tobacco." Biotechnology (NY) **10**: 790-4.
- Pelletier, M. K., I. E. Burbulis and B. Winkel-Shirley (1999). "Disruption of specific flavonoid genes enhances the accumulation of flavonoid enzymes and end-products in *Arabidopsis* seedlings." Plant Mol Biol **40**: 45-54.
- Phillips, J., O. Artsaenko, U. Fiedler, C. Horstmann, H. P. Mock, K. Muntz and U. Conrad (1997). "Seed-specific immunomodulation of abscisic acid activity induces a developmental switch." Embo J **16**: 4489-96.
- Recourt, K., J. Schripsema, J. W. Kijne, A. A. van Brussel and B. J. Lugtenberg (1991). "Inoculation of *Vicia sativa* subsp. *nigra* roots with *Rhizobium leguminosarum* biovar *viciae* results in release of nod gene activating flavanones and chalcones." Plant Mol Biol **16**: 841-52.
- Recourt, K., A. J. van Tunen, L. A. Mur, A. A. van Brussel, B. J. Lugtenberg and J. W. Kijne (1992). "Activation of flavonoid biosynthesis in roots of *Vicia sativa* subsp. *nigra* plants by inoculation with *Rhizobium leguminosarum* biovar *viciae*." Plant Mol Biol **19**: 411-20.

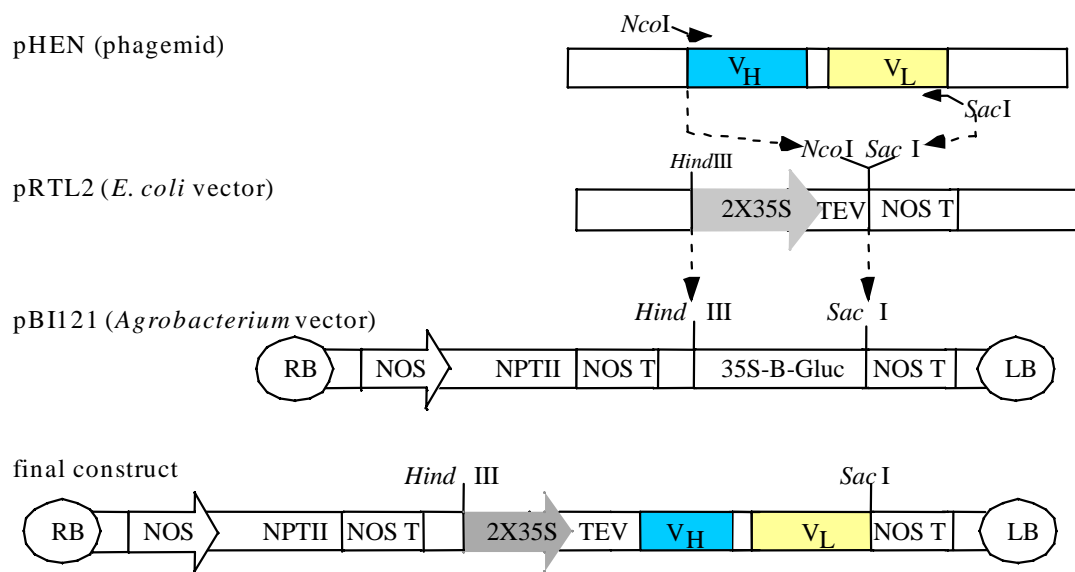
- Sambrook, J., E. F. Fritsch and T. Maniatis (1989). *Molecular Cloning: A Laboratory Manual*, 2<sup>nd</sup> ed. (Cold Spring Harbor, NY: Cold Spring Harbor Laboratory Press).
- Saslowsky, D. E., C. D. Dana and B. Winkel-Shirley (2000). "An allelic series for the chalcone synthase locus in *Arabidopsis*." *Gene* **255**: 127-138.
- Saslowsky, D. and B. S. J. Winkel-Shirley (2001). "Localization of flavonoid enzymes in *Arabidopsis thaliana* roots." *Plant J in press*.
- Shirley, B. W., W. L. Kubasek, G. Storz, E. Bruggemann, M. Koornneef, F. M. Ausubel and H. M. Goodman (1995). "Analysis of *Arabidopsis* mutants deficient in flavonoid biosynthesis." *Plant J* **8**: 659-71.
- Swain, T. (1976). "Nature and Properties of Flavonoids." In: *Chemistry and Biochemistry of Plant Products*. TW Goodwin, ed. Academic Press, New York.
- Tavladoraki, P., E. Benvenuto, S. Trinca, D. De Martinis, A. Cattaneo and P. Galeffi (1993). "Transgenic plants expressing a functional single-chain Fv antibody are specifically protected from virus attack." *Nature* **366**: 469-72.
- Tavladoraki, P., A. Girotti, M. Donini, F. J. Arias, C. Mancini, V. Morea, R. Chiaraluce, V. Consalvi and E. Benvenuto (1999). "A single-chain antibody fragment is functionally expressed in the cytoplasm of both *Escherichia coli* and transgenic plants." *Eur J Biochem* **262**: 617-24.
- van der Meer, I. M., M. E. Stam, A. J. van Tunen, J. N. Mol and A. R. Stuitje (1992). "Antisense inhibition of flavonoid biosynthesis in petunia anthers results in male sterility." *Plant Cell* **4**: 253-62.
- Veit, M. and G. F. Pauli (1999). "Major flavonoids from *Arabidopsis thaliana* leaves." *J Nat Prod* **62**:1301-1303.

- Winkel-Shirley, B. (1999). "Evidence for enzyme complexes in the phenylpropanoid and flavonoid pathways." Physiologia Plantarum **107**: 142-149.
- Winkel-Shirley, B. S. J. (2001). "A colorful model for genetics, biochemistry, cell biology, and biotechnology." Plant Physiol *in press*.
- Yuan, Q., W. Hu, J. J. Pestka, S. Y. He and L. P. Hart (2000). "Expression of a functional anti-zearalenone single-chain Fv antibody in transgenic *Arabidopsis* plants." Appl Environ Microbiol **66**(8): 3499-505.



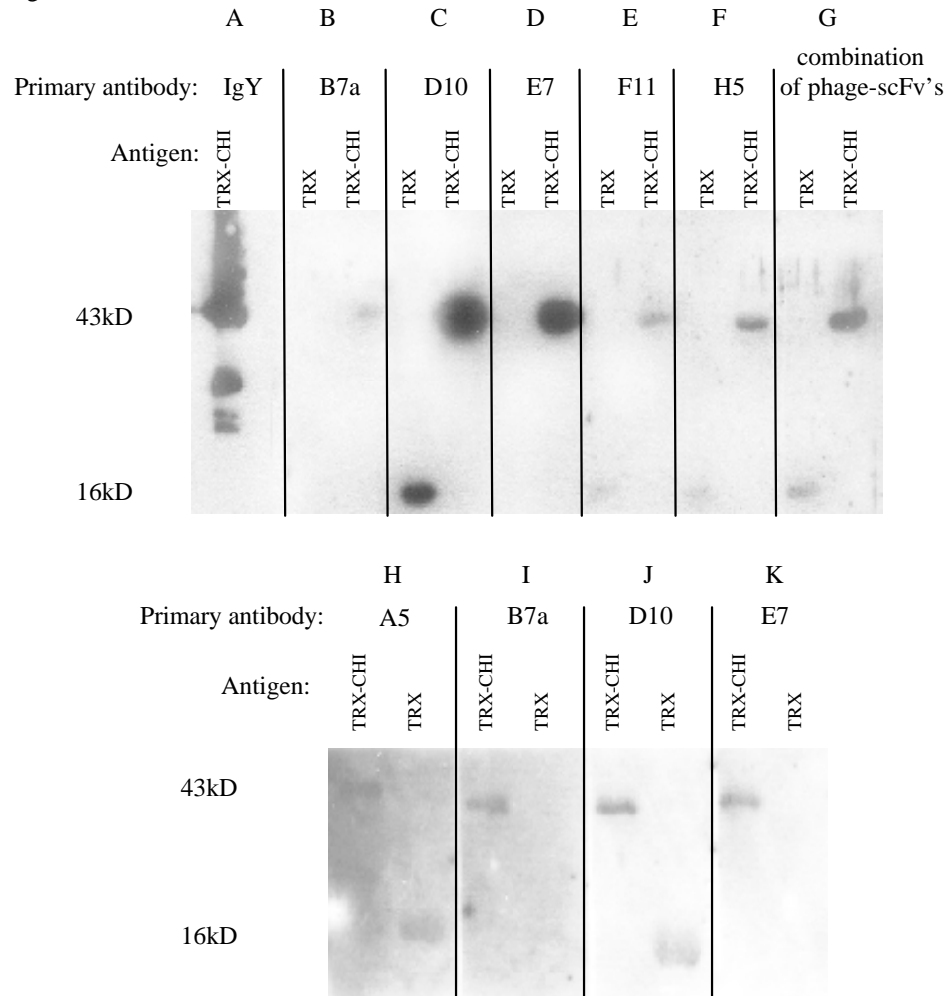
**Figure 1.** Constructs for plant transformation. The scFv genes were first amplified from the pHEN phagemid by PCR using primers described in the materials and methods section. The primers were designed to introduce *Nco*1 and *Sac*1 sites flanking the amplified gene. The amplified fragment was subcloned into the *Nco*1-*Sac*1 cloning site of pRTL2, an *E. coli* vector that features a double-enhanced 35S cauliflower mosaic virus (CaMV) promoter and a translational enhancer from tobacco etch virus (TEV). The entire scFv expression cassette was then subcloned into pBI121 using *Hind*III and *Sac*I sites, replacing the original 35S CaMV promoter and  $\beta$ -glucuronidase gene of this vector. The resulting plasmid constructs were moved into the GV3101 strain of *Agrobacterium*, which was used in plant transformation experiments.

Figure 1.



**Figure 2.** Immunoblots using anti-CHI phage-scFv's. Immunoblots containing equimolar amounts of recombinant thioredoxin-chalcone isomerase (TRX-CHI) and thioredoxin (TRX) were probed with anti-CHI antibodies. Each blot was probed with polyclonal anti-CHI IgY (panel A), a unique anti-CHI phage-scFv (panels B, C, D, E, F, H, I, J, and K), or a combination of various anti-CHI phage-scFv's (panel G). The anti-CHI phage-scFv mix used to probe panel G was, in effect, a polyclonal antibody mix, which was comprised of equimolar amounts of anti-CHI phage-scFv's that were used for panels B to F. For all phage-probed panels,  $10^7$  phage particles/ml were used as the primary antibody. Panels B and I, C and J, D and K represent duplicate experiments.

Figure 2.



**Figure 3.** Sequences of anti-CHI scFv genes and corresponding translations of V<sub>H</sub> regions. The translational enhancer from tobacco etch virus (TEV) is highlighted in all sequences as a point of reference. The various components of the scFv genes that immediately follow the TEV sequence are labeled at the top of the sequence alignment. Each scFv encodes for an antibody V<sub>H</sub> (heavy-variable domain), which is comprised of four framework regions (FR), interspersed with three complementarity determining regions (CDR). The scFv also encodes for an antibody V<sub>L</sub> (light-variable domain), which is invariant among all the scFv's in the particular library used. Between the V<sub>H</sub> and the V<sub>L</sub> domains is a flexible hinge that links the two together (yellow high-light). The start codon is the first ATG in the FR1 region of the V<sub>H</sub> domain. The differences between scFv's, shaded pink in the FRs and shaded green in the CDRs, are found only in the V<sub>H</sub> domain. One of the sequences, A5, has an amber codon (TAG in the FR2 region, shaded red), which is read as glutamate in amber suppressor strains such as *E. coli* TG-1 bacteria, but as a stop codon in plants. An alignment of the gene translations of the V<sub>H</sub> domains is also shown.

Figure 3.

Sequence alignment of scFv genes

```

-----TEV non-translated region; translational enhancer -----
A5 >ATTTTCATTTGGAGAGGACCTCGAGAATTCTCAACACAACATATACAAAACAAACGAATCTCAAGCAATCAAGCATTCTACTTC
B7 >ATTTTCATTTGGAGAGGACCTCGAGAATTCTCAACACAACATATACAAAACAAACGAATCTCAAGCAATCAAGCATTCTACTTC
D10 >ATTTTCATTTGGAGAGGACCTCGAGAATTCTCAACACAACATATACAAAACAAACGAATCTCAAGCAATCAAGCATTCTACTTC
E7 >ATTTTCATTTGGAGAGGACCTCGAGAATTCTCAACACAACATATACAAAACAAACGAATCTCAAGCAATCAAGCATTCTACTTC

                                     VH >>>
-----TEV non-translated region; translational enhancer -----FR1---FR1---
TATTGCAGCAATTTAAATCATTTCCTTTTAAAGCAAAGCAATTTTCTGAAAATTTTACCATTACGAACGATAGCCATGGCCCAGGTG
TATTGCAGCAATTTAAATCATTTCCTTTTAAAGCAAAGCAATTTTCTGAAAATTTTACCATTACGAACGATAGCCATGGCCCAGGTG
TATTGCAGCAATTTAAATCATTTCCTTTTAAAGCAAAGCAATTTTCTGAAAATTTTACCATTACGAACGATAGCCATGGCCCAGGTG
TATTGCAGCAATTTAAATCATTTCCTTTTAAAGCAAAGCAATTTTCTGAAAATTTTACCATTACGAACGATAGCCATGGCCCAGGTG

FR1---FR1---FR1---FR1---FR1---FR1---FR1---FR1---FR1---FR1---FR1---FR1---FR1---FR1---FR1---FR1---CDR--
CAGCTGGTGCAGTCTGGGGCTGAGGTCAGAAGCCTCTCTCCCTCAGTGAAGTCTCCTTCAAGGCTTCTGGATACACCTTCAACAACAA
CAGCTGGTGGAGTCTGGGGGAGGCTGTGGTACGCTTGGGGGGTCCCTGAGACTCTCCTGTGCAGCCCTGTGGATTACCTTTGATGATTA
CAGCTGGTGGAGTCTGGGGGAGGCTGGTCCAGCCTGGGAGGTCCCTGAGACTCTCCTGTGCAGCCCTGTGGATTACCTTCAGTACCTA
CAGCTGGTGGAGTCTGGGGGAGGCTTGGTAAAGCCTGGGGGGTCCCTTAGACTCTCCTGTGCAGCCCTGTGGATTACCTTCAGTAAACGC

CDR1
CDR2
---CDR---CDR---FR2---FR2---FR2---FR2---FR2---FR2---FR2---CDR---CDR---CDR---CDR---CDR---CDR
CTTATGCTGCTGGGTCCGCCAGGCTCCAGGCAAGGCAAGGACTTGAGTGGATGGGAACATAAATGCTGGC--CAATGGTAAACACAACATA
TCGATGCTGGGTCCGCCAGGCTCCAGGCAAGGCAAGGACTTGAGTGGATGGGAACATAAATGCTGGC--CAATGGTGGAGCACAGGTT
TCCATGCTGCTGGGTCCGCCAGGCTCCAGGCAAGGCAAGGACTTGAGTGGATGGGTGGCAGTATATCATAT-----TGATGGAAACAATATACT
CTCATGCTGCTGGGTCCGCCAGGCTCCAGGCAAGGCAAGGACTTGAGTGGATGGGTGGCAGTATATATAAACAACAACGATGATGGTGGACAACAGACT

---CDR---CDR---CDR---FR3---FR3---FR3---FR3---FR3---FR3---FR3---FR3---FR3---FR3---FR3---FR3---FR3---FR3---FR3---FR3---
GCAAGATTC--AGGGCAGATCACCATAAACAGCGACACCGTCCATGAGCACAGCCACAGGAGCTGACAGCCTGAGATCTGAG
ATGCAGACTCTGTGAAGGGCCGATTCCACCATCTCCAGAGACAACGCCAAGAACTCCCTGTATCTGCAAATGAACAGTCTGAGAGCCGAG
ACGACAGACTCTGTAAGGGCCGATTCCACCATCTCCAGAGACAATTCCAAGAACACGCTGTATCTGCAAATGAACAGCCTGAGAGCTGAG
ACGCTGACCCGTGAAAGGCAAGATTACCATCTCAGAGATGATTCAAAAACACGCTGTATCTGCAAATGAACAGCCTGAAACCGAG

CDR3
---FR3---FR3---FR3---FR3---CDR---CDR---CDR---CDR---FR4---FR4---FR4---FR4---FR4---FR4****
GACACGGCCGTGTATTACTGTGCAAGATCGACTCCCTGCATTAACGGCGGTGGGGCCAAGGTACCCTGGTACCCTGTGCGAGAGGTTGG
GACACAGCCGTGTATTACTGTGCAAGATGCGGCTATGCGCT---TGGATTTGGGGCCAAGGTACCCTGGTACCCTGTGCGAGAGGTTGG
GACACGGCCGTGTATTACTGTGCAAGATGTAAGTGC---GGATGGTGGGGCCAAGGTACCCTGGTACCCTGTGCGAGAGGTTGG
GACACGGCCGTGTATTACTGTGCAAGATGACGACTAAGC---CTAATCTGCTGGGGCCAAGGTACCCTGGTACCCTGTGCGAGAGGTTGG

                                     VL >>>
*****Hinge region*****
AGGCGGTTTCAGGCGGAGGTGGCTCTGGCGGTGGCGGATCGTCTGAGCTGACTCAGGACCCTGCTGTG
AGGCGGTTTCAGGCGGAGGTGGCTCTGGCGGTGGCGGATCGTCTGAGCTGACTCAGGACCCTGCTGTG
AGGCGGTTTCAGGCGGAGGTGGCTCTGGCGGTGGCGGATCGTCTGAGCTGACTCAGGACCCTGCTGTG
AGGCGGTTTCAGGCGGAGGTGGCTCTGGCGGTGGCGGATCGTCTGAGCTGACTCAGGACCCTGCTGTG

```

Sequence Alignment of Translated V<sub>H</sub> Domains

```

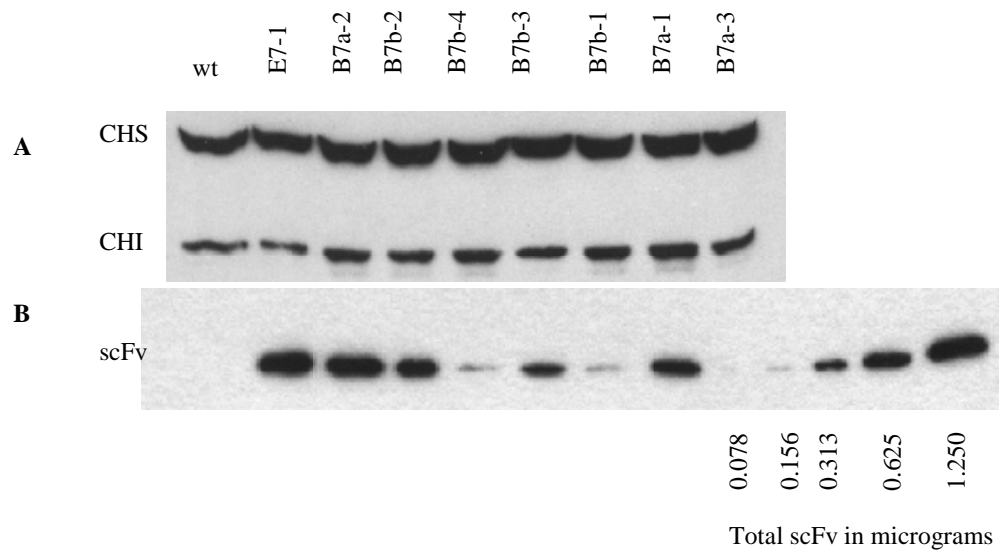
A5 >MAQVQLVQSGAEVKPKLSVKVSPKASGYFTFTNFMHWVQAPGQGLEWVSGI--NAGNGNTTYAOKFOGRVTIIRDTSMSTAYIT
B7 >MAQVQLVESGGGVVPPGSLRLSCLASGFTFDYQMSWVRQAPGKLEWVSGI--NWNNGSTCYADSVKGRFTISRDNKNSLYL
D10 >MAQVQLVESGGGVVQPGKSLRLSCLASGFTFSYAMHWVRQAPGKLEWVAVI--SYDGSNKYADSVKGRFTISRDNKNTLYL
E7 >MAQVQLVESGGGLVKPPGSLRLSCLASGFTFSNAWMSWVRQAPGKLEWVGRIGKSKTDGGTTDYAAEFVKGRFTISRDKNTLYL

ELSLRSEDTAVYYCARSTPVITARWQGTLVTVSR
QMNSLRRAEDTAVYYCARRRYALDY-WGQGLTVTVSR
QMNSLRRAEDTAVYYCARRMNA-EW-WGQGLTVTVSR
QMNSLRTEDTAVYYCARSTSKAIV-WGQGLTVTVSR

```

**Figure 4.** Accumulation of scFv, CHS, and CHI protein in transgenic plants. For blot A, each lane was loaded with 25 µg of plant TSP. The blot was probed simultaneously with affinity-purified dilutions of rabbit-anti-CHS (1:2000) and chicken-anti-CHI (1:1000), and processed as discussed in the materials and methods section. For blot B, 1.25 µg of plant TSP was loaded for each of the high-level scFv expressor (E7-1, B7a-2, and B7b-2), whereas 10 µg of TSP was loaded for each plant that expressed lower amounts of scFv (B7b-4, B7b-3, B7b-1, and B7a-1). In addition, a dilution series using a previously-quantified sample, B7a-3, was loaded as a standard for the quantitation of scFv-expression levels in each transgenic plant. A 1:1000 dilution of mouse monoclonal 9E10 anti-c-myc antibody was used as the primary probe.

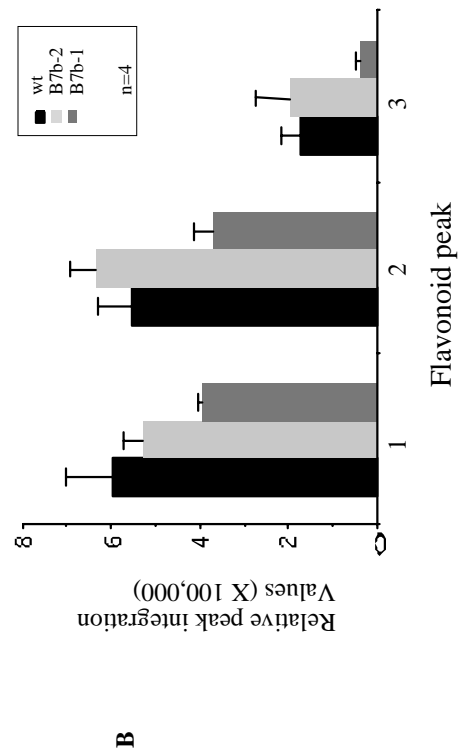
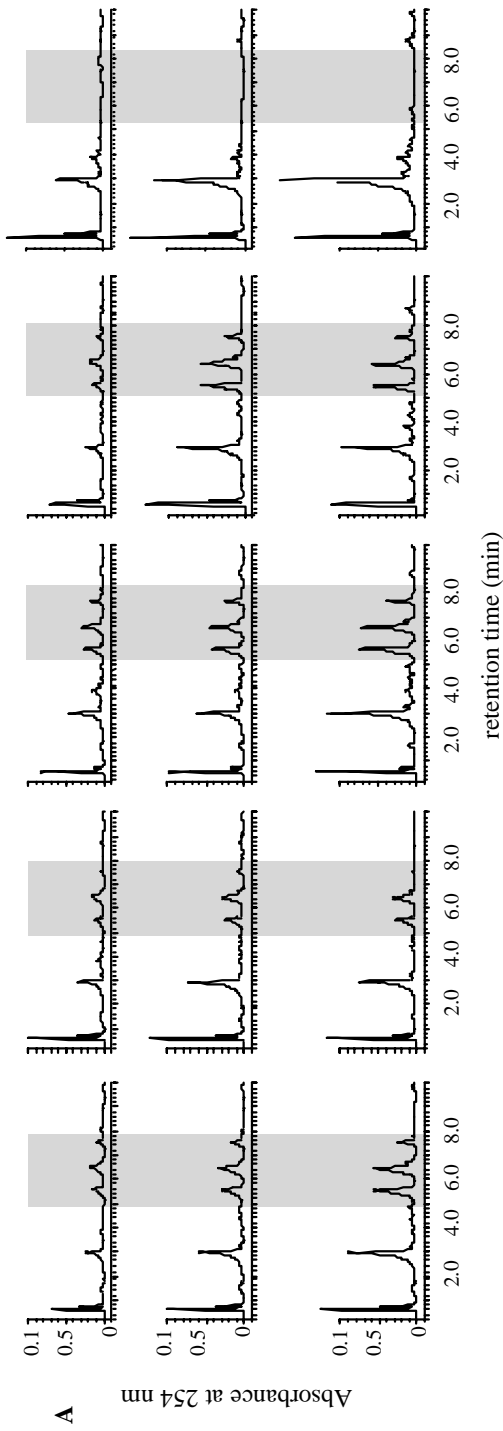
Figure 4.





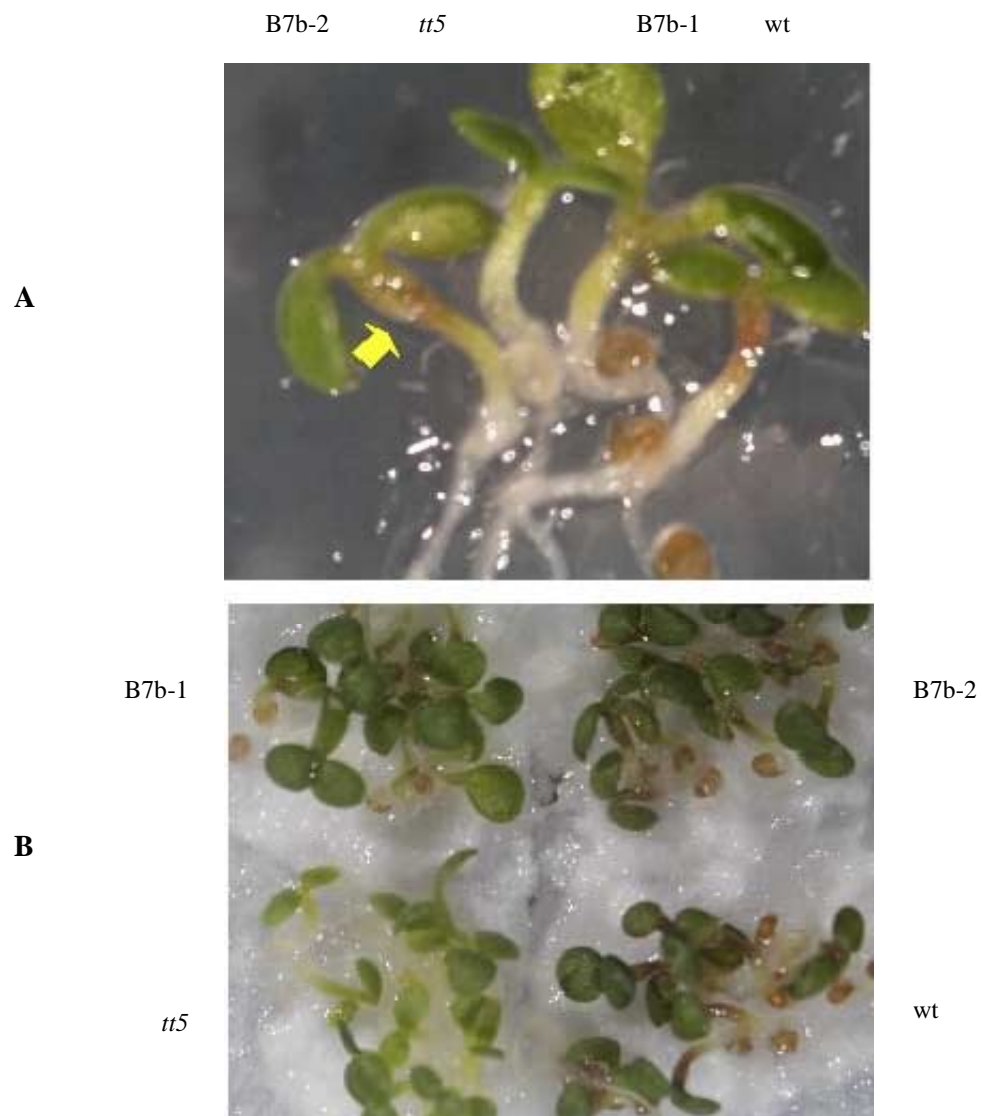
**Figure 5.** Analysis of flavonoid accumulation in transgenic seedlings expressing an anti-CHI scFv. All the transgenic lines tested in this analysis were transformed with the same scFv gene, but show different expression levels for the transgene. (A) Flavonoids from 30 seedlings of five representative plant groups (wild-type; low-level expressor: B7b-1; mid-level expressor: B7b-2; hi-level expressor: B7a-2; CHS-null mutant: *tt4*) were extracted on days 3, 5, and 7 and analyzed by HPLC. (B) Peak integrations from four independent HPLC-profiling experiments using equivalent amounts of 5-day-old seedlings from the B7b-1 and B7b-2 lines in comparison with wild-type are also shown.

Figure 5.



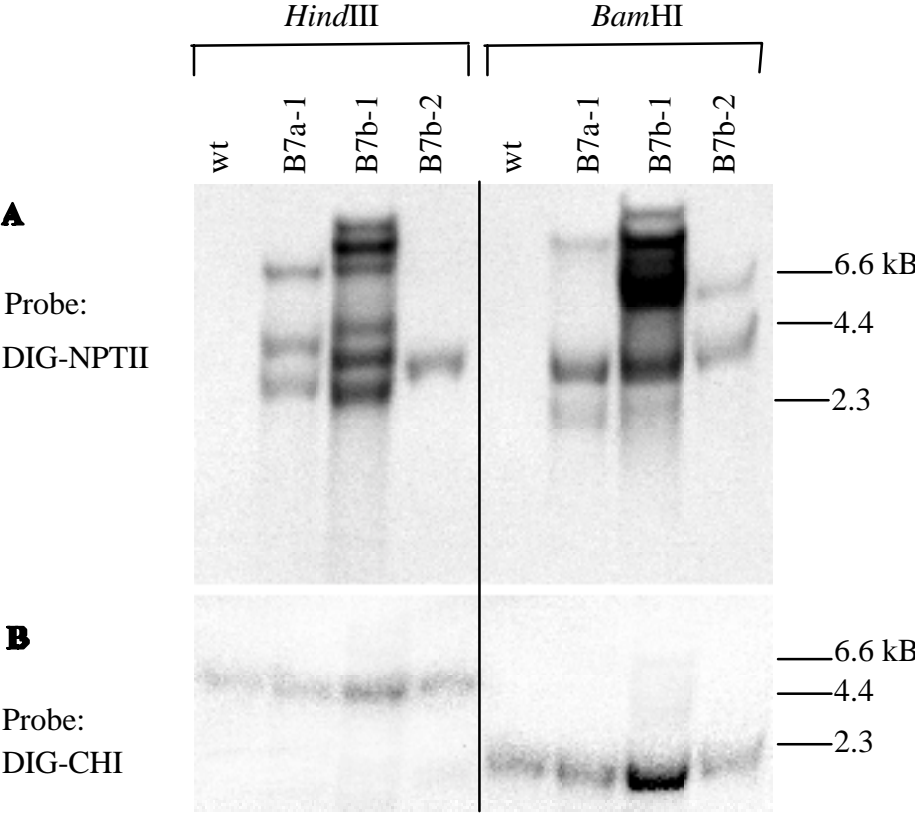
**Figure 6.** Visible anthocyanin differences among transgenic, wild-type, and mutant five-day old seedlings. All plants were grown under 24-hour daylight on MS plates supplemented with 2% sucrose. (A) By the fifth day, anthocyanin accumulation in the upper portion of hypocotyls (indicated by a yellow arrow on B7b-2) is evident among wild-type (wt) and B7b-2 transgenic seedlings. Anthocyanins are completely absent in the CHI-null mutant, *tt5*, while a slight reduction of these pigments is observed among B7b-1 transgenic seedlings. (B) To illustrate at the population level the general reduction or complete absence of anthocyanin pigments in B7b-1 or *tt5*, respectively, relative to wild-type and B7b-2, multiple seedlings from each of the four lines are shown.

Figure 6.



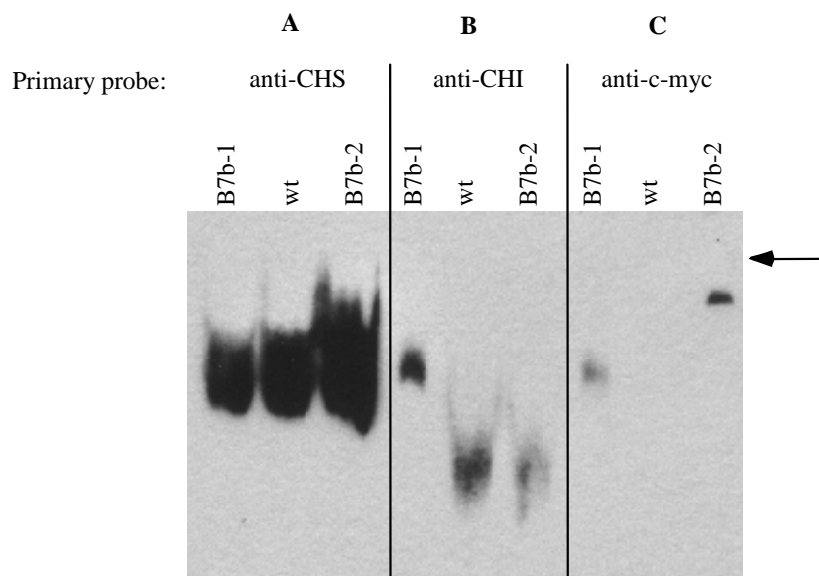
**Figure 7.** Determination of number of transgene insertions in B7b-1 and other selected transgenic lines. For blot A, 1 µg of genomic DNA from each plant was digested overnight with *Hind*III or *Bam*HI. The digested samples were then loaded in the order as shown in the figure. The blot was initially hybridized with DIG-labeled probe that recognizes NPTII of the T-DNA insert. Since *Hind*III and *Bam*HI are unique restriction sites within the T-DNA region, digestion of genomic DNA with either of these two enzymes should reveal the number of T-DNA insertions in each transgenic line when subjected to Southern analysis using a probe that exclusively recognizes only one side of the T-DNA region bisected by *Hind*III or *Bam*HI. To confirm that the DNA had been fully digested, the blot was stripped, then reprobbed with DIG-labeled CHI DNA (blot B).

Figure 7.



**Figure 8.** Protein mobility shift assay using non-denaturing 10% PAGE. Eighty micrograms of plant lysate were loaded per lane, except for B7b-2 of blot C which was underloaded (5  $\mu$ g) to approximate the scFv expression level in B7b-1. Blot A was probed with rabbit-anti-CHS, blot B with chicken-anti-CHI, blot C with mouse monoclonal 9E10 anti-c-myc. The top of the gel is marked with an arrow.

Figure 8.





**Table 1.** Level of scFv expression in transgenic plants.

Transgenic line	Expression level (% scFv in TSP)
B7a-1	0.22*
B7a-2	3.84
B7a-3	2.00
B7b-1	0.07*
B7b-2	1.45*
B7b-3	0.18*
B7b-4	0.09*
E7-1	3.76

\* average of readings from two densitometric assays

## Chapter 3

## Conclusions

The first demonstration of cytoplasmic expression of antibody fragments in plant cells has drawn much interest into the possibility of targeting a variety of cytoplasmic components using variants of the basic antibody structure (Hiatt et al. 1989). Among the many interesting targets in the plant cell cytoplasm are enzymes involved in metabolism. Facilitating the exploration of this concept is the development of the phage display technique and the availability of recombinant phage libraries with diverse repertoires of antibody fragments. This technology offers the potential for isolating genes encoding high-affinity binders for virtually any target enzyme. To date, however, no research group has published work showing immunomodulatory effects of enzyme-targeted antibody fragments in transgenic plants. Our project, therefore, appears to be the first proof of principle for antibody-based metabolic regulation.

In pursuing this project, some previous findings were confirmed and novel observations were made. First, it was shown that functional antibodies in the scFv format could be expressed in plants. This has been demonstrated in a number of experiments that involved target antigens such as phytochrome (Owens et al. 1992), abscissic acid (Artsaenko et al. 1995; Conrad and Fiedler 1998), and invasive plant pathogens (Franconi et al. 1999; Harper et al. 1999; Tavladoraki et al. 1993) using scFv's derived from monoclonal lines generated by hybridoma technology. Phenotypic alterations in one transgenic line that expresses scFv's at a low level (B7b-1), together with direct evidence of scFv-CHI interaction in protein mobility shift assays, indicate that the scFv's are in the same cellular compartment as CHI, the cytosol, and directly bind the target protein. This implies that at least for the anti-CHI scFv's expressed in B7b-1, the reducing environment of the cytosol does not abolish antibody functionality, presumably because

this scFv is not dependent on disulfide bonds for retaining a functional structure. There is evidence that cytosol-targeted scFv's accumulate at much lower concentrations than similar scFv's targeted to other compartments, suggesting that the absence of disulfide bridges could lead to instability (Bruyns et al. 1996; Fiedler et al. 1995; Firek et al. 1993; Schouten et al. 1996). On the other hand, a large part of an scFv's stability in different cellular compartments could be attributed to primary amino acid sequence (De Jaeger et al. 2000; Tavladoraki et al. 1999). Thus, in cases where functional scFv's accumulate to levels that affect the activities of the cytosolic targets, disulfide bridges probably do not have a significant contribution to the structural stability and/or functionality of scFv's. It cannot be ruled out, however, that the reducing environment of the cytosol somewhat destabilized the scFv's used in this project. Nonetheless, numerous lines showed good scFv expression, and a clear binding activity could be seen in one transgenic line.

In expressing scFv's to alter secondary metabolism, the targeted enzyme is not abolished; thus, complete elimination of end-products could be difficult, if not impossible, to achieve. Activity is presumably dependent on the strength of the interaction of the scFv with the target enzyme and the location of the epitope it recognizes. Considering that most plants have suites of homeostatic mechanisms for maintaining steady-state levels of metabolic intermediates and end-products (e.g. feedback mechanisms and cross-talk between pathways competing for the same precursors), and considering that transcription of the structural genes is a major regulatory mechanism for flavonoid metabolism (Koes et al. 1994), it is not surprising that the observed effects of CHI-targeted scFv expression in *Arabidopsis* appear subtle in comparison to those of other genetic engineering strategies aimed at altering flavonoid

metabolism, such as anti-sense CHS mRNA expression (Courtney-Gutterson et al. 1994) and activation tagging of regulatory genes (Borevitz et al. 2000) to drastically decrease or increase the levels of phenylpropanoid pathway enzymes.

An interesting finding from this project is that overexpression of scFv's does not necessarily lead to an accumulation of functional binders. In fact, it appears that an scFv concentration threshold exists that, when surpassed, results in the absence of any phenotypic effect. This may be due to scFv aggregation, as suggested by the presence of a high molecular-weight band in lysates of a high-level expressor in immunoblotting assays performed under non-denaturing conditions. This finding suggests the importance of generating multiple independent transgenic lines with varying levels of transgene expression, as it is likely that each scFv is only functional within a limited concentration range *in planta*.

Finally, at least for CHI, it appears that down-regulation can be effected by the interaction of an scFv with a structural domain. Since no significant kinetic differences were observed for CHI in lysates from wild-type and transgenic seedlings in replicate activity assays, interference with catalytic activity does not appear to be the cause of phenotypic alteration in transgenic plants that show reduced accumulation of flavonol glycosides. On the other hand, binding of scFv to a structural site could impair the ability of CHI to associate with other enzymes of flavonoid metabolism, leading to reduced levels of specific pathway end-products by interfering with channeling.

This project has shown that scFv's can be used to alter the metabolic flux of a targeted pathway. Further refinements, however, could be incorporated in the strategy to improve the predictability of the outcome of scFv expression. For instance, for the phage

display panning procedure, scFv selection conditions could be changed to more closely resemble the physiological environment inside the specific cellular compartment where the scFv is targeted for expression (e.g. for cytosolic expression, performing panning under reducing conditions). In addition, plant promoters of varying strengths could be used to drive scFv expression. This may aid in generating phenotypically-altered transgenic plants considering that the scFv appears to be effective only within a narrow concentration range.

Among practical applications of intracellular antibody expression is the modification of flower color. For example, the enzymes F3'H and F3'5'H, which are directly responsible for the hydroxylation pattern of the B ring of colored flavonoids, could be targeted to favor one color over another. The same approach could be applied to redirect flux towards branch pathways that lead to the synthesis of secondary plant products that have known therapeutic potential such as the isoflavonoids genistein and daidzein. It could even be utilized in crop improvement such as the development of forage crops with enhanced levels of condensed tannins to improve digestibility. However, the use of scFv's is not limited to flavonoid metabolism. For instance, scFv's could be used to reduce the activity of enzymes producing certain alkaloids that are antifeedants in forage crops. Other objectives of metabolic engineering that could utilize an scFv-based approach may include the improvement of resistance against insect and microbial pathogens through intensified production of phytoalexins, and the improvement of nutritional value of crops for human consumption by augmenting the production of other natural products such as carotenoid pigments. From a basic science point of view, this novel approach can even aid in the discovery and understanding of new compounds

resulting from increased flux through poorly-characterized branch pathways. In summary, scFv-mediated interference of enzyme function is a potentially powerful complement to current metabolic engineering strategies. It will be exciting to see future developments that fully harness its capabilities now that it is established that immunomodulation of secondary product biosynthesis can be accomplished in transgenic plants.

## References

- Artsaenko, O., M. Peisker, U. zur Nieden, U. Fiedler, E. W. Weiler, K. Muntz and U. Conrad (1995). "Expression of a single-chain Fv antibody against abscisic acid creates a wilted phenotype in transgenic tobacco." Plant J **8**: 745-50.
- Borevitz, J. O., Y. Xia, J. Blount, R. A. Dixon and C. Lamb (2000). "Activation tagging identifies a conserved MYB regulator of phenylpropanoid biosynthesis." Plant Cell **12**: 2383-2394.
- Bruyns, A. M., G. De Jaeger, M. De Neve, C. De Wilde, M. Van Montagu and A. Depicker (1996). "Bacterial and plant-produced scFv proteins have similar antigen-binding properties." FEBS Lett **386**: 5-10.
- Conrad, U. and U. Fiedler (1998). "Compartment-specific accumulation of recombinant immunoglobulins in plant cells: an essential tool for antibody production and immunomodulation of physiological functions and pathogen activity." Plant Mol Biol **38**: 101-9.
- Courtney-Gutterson, N., C. Napoli, C. Lemieux, A. Morgan, E. Firoozabady and K. E. Robinson (1994). "Modification of flower color in florist's chrysanthemum: production of a white-flowering variety through molecular genetics." Biotechnology (N Y) **12**: 268-71.
- De Jaeger, G., E. Fiers, D. Eeckhout and A. Depicker (2000). "Analysis of the interaction between single-chain variable fragments and their antigen in a reducing intracellular environment using the two- hybrid system." FEBS Lett **467**: 316-20.



- Fiedler, U. and U. Conrad (1995). "High-level production and long-term storage of engineered antibodies in transgenic tobacco seeds." *Biotechnology (N Y)* **13**: 1090-3.
- Firek, S., J. Draper, M. R. Owen, A. Gandecha, B. Cockburn and G. C. Whitelam (1993). "Secretion of a functional single-chain Fv protein in transgenic tobacco plants and cell suspension cultures [published erratum appears in *Plant Mol Biol* 1994 Mar; 24(5):833]." *Plant Mol Biol* **23**: 861-70.
- Franconi, R., P. Roggero, P. Pirazzi, F. J. Arias, A. Desiderio, O. Bitti, D. Pashkoulov, B. Mattei, L. Bracci, V. Masenga, R. G. Milne and E. Benvenuto (1999). "Functional expression in bacteria and plants of an scFv antibody fragment against tospoviruses." *Immunotechnology* **4**: 189-201.
- Harper, K., R. L. Toth, M. A. Mayo and L. Torrance (1999). "Properties of a panel of single chain variable fragments against potato leafroll virus obtained from two phage display libraries." *J Virol Methods* **81**: 159-68.
- Hiatt A., R. Cafferkey and K. Bowdish (1989). "Production of antibodies in transgenic plants." *Nature* **342**: 76-78.
- Koes, R. E., F. Quattrocchio, J. N. M. Mol (1994). "The flavonoid biosynthetic pathway in plants: function and evolution." *BioEssays* **16**:123-132.
- Schouten, A., J. Roosien, F. A. van Engelen, G. A. de Jong, A. W. Borst-Vreessen, J. F. Zilverentant, D. Bosch, W. J. Stiekema, F. J. Gommers, A. Schots and J. Bakker (1996). "The C-terminal KDEL sequence increases the expression level of a single- chain antibody designed to be targeted to both the cytosol and the secretory pathway in transgenic tobacco." *Plant Mol Biol* **30**: 781-93.

Tavladoraki, P., E. Benvenuto, S. Trinca, D. De Martinis, A. Cattaneo and P. Galeffi

(1993). "Transgenic plants expressing a functional single-chain Fv antibody are specifically protected from virus attack." Nature **366**: 469-72.

Tavladoraki, P., A. Girotti, M. Donini, F. J. Arias, C. Mancini, V. Morea, R. Chiaraluce,

V. Consalvi and E. Benvenuto (1999). "A single-chain antibody fragment is functionally expressed in the cytoplasm of both *Escherichia coli* and transgenic plants." Eur J Biochem **262**: 617-24.

## Appendices

## A. Isolation of anti-CHS scFv's

The original goal of the project was to test the feasibility of scFv-mediated immunomodulation of flavonoid metabolism in *Arabidopsis* using antibodies against the first two enzymes of the pathway, CHS and CHI. These enzymes are relatively well-characterized as a result of the considerable efforts that have been focused on flavonoid biosynthesis. Genes encoding both enzymes have been cloned and sequenced in *Arabidopsis* (Feinbaum and Ausubel 1988; Shirley et al. 1992). Using bacterial protein over-expression systems, recombinant versions of these enzymes have been produced in *E. coli* and subsequently used to generate polyclonal antibodies (Cain et al. 1997; Pelletier et al. 1997). The ability to produce recombinant protein is critical for the success in screening the phage display library because the screening technique is highly dependent on an abundant supply of relatively pure antigen. Another advantage of these enzymes is the availability of mutant lines that can serve as benchmarks for measuring the extent of immunomodulation of an scFv targeted to either CHS or CHI. The *Arabidopsis* mutants that are defective in steps catalyzed by CHS and CHI, *tt4* and *tt5*, respectively, are easy to identify due to their distinctive yellow seed coat color as compared to the dark-brown seeds of wild-type plants (reviewed in Shirley et al. 1995). These mutants have also been characterized by HPLC analysis, which revealed major changes in levels of glycosylated flavonols and the related compounds, sinapic acid esters, with respect to wild-type (Li et al. 1993). Because the isolation of anti-CHI scFv's has already been discussed in the previous chapter, only the effort to isolate anti-CHS scFv's will be described here.

## Materials and Methods

### *Panning for CHS-binders*

In addition to panning the phage display antibody library (Nissim et al. 1994) for scFv's that bind to CHI, the library was also panned for CHS binders. The protocol used was essentially as described for the isolation of CHI-binders in Chapter 2, except that TRX-CHS (Pelletier et al. 1999) was used for the first and third round of screening and GST-CHS (Cain et al. 1997) for the second and fourth. Individual isolates after the fourth round were subjected to ELISA assays to test for reactivity against a panel of approximately equimolar amounts of antigens. In the assay, each panel consisted of four wells that had each been pre-coated with a 2% MPBS solution containing either 10 µg/ml TRX-CHS, 4 µg/ml TRX, 10 µg/ml GST-CHS, or 4 µg/ml GST at room temperature overnight. The ELISA plates were processed as described for CHI. In addition, immunoblot analysis was attempted as described for CHI, but the initial result was not informative because of the unexpected cross-reactivity of commercial polyclonal anti-M13 phage coat antibodies with denatured CHS.

### *Sequencing of scFv isolates*

Sequencing of scFv genes from four isolates was performed using the protocol described for anti-CHI scFv isolates in Chapter 2.

## Results and Discussion

After four rounds of panning for CHS binders, eight bacteriophage clones were isolated. These were subjected to an ELISA assay designed to test the specificity of each

scFv clone for CHS. Figure 1 shows the relative OD<sub>450</sub> readings for each clone with a given antigen. The signal reflects the amount of scFv bound to the antigen in each well. Varying degrees of specificity for binding to CHS were observed among the scFv clones. This result is comparable to the variability observed among the anti-CHI scFv clones that were tested for specificity for binding to CHI. All the anti-CHS isolates appeared to recognize TRX-CHS better than TRX alone, while seven of the eight isolates also appeared to recognize GST-CHS better than GST alone. This trend indicates that the scFv isolates recognize CHS, and to a lesser extent, the fusion partners. Since each isolate is monoclonal (i.e. one scFv gene encodes for one unique binding structure), the general cross-reactivity of all the isolates with TRX and GST was unexpected. It is possible that these fusion partners have structural features resembling certain CHS epitopes. Another possibility is that the antigen preparations contained a common bacterial protein that co-purified with the over-expressed proteins and was recognized by the scFv's. Four rounds of panning could have resulted in an enrichment of scFv's that recognized the common bacterial protein. In the ELISA plate used for the specificity assay, wells that were coated with a solution of TRX-CHS or GST-CHS at 10 µg/ml would have had a higher amount of this bacterial protein compared with wells coated with a solution of TRX or GST at 4 µg/ml. It is possible that recognition of this bacterial protein, and not CHS, by the scFv's could have resulted in heightened OD<sub>450</sub> readings of wells coated with TRX-CHS or GST-CHS relative to wells coated with just TRX or GST.

Sequence analysis of four of the eight isolates revealed that three were identical, while A7 contained a slightly different sequence upstream of the scFv start codon (Fig. 2). The A7 V<sub>H</sub> region, however, did not deviate from the consensus V<sub>H</sub> sequence of the

isolates, suggesting that the difference in A7 was a cloning artifact. It is possible that the presence of a highly-antigenic CHS epitope may have resulted in the over-representation of only one type of binder. Similarly, it is possible that the particular scFv encoded by the consensus gene confers a selective advantage to the *E. coli* host that produces it.

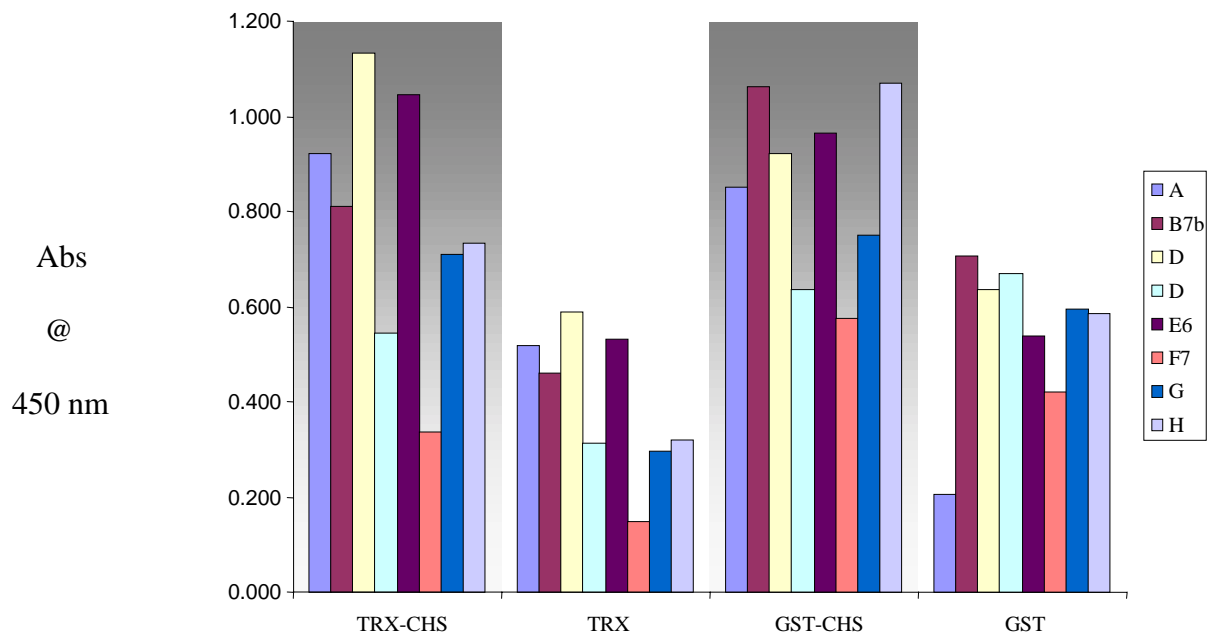
Surprisingly, the three anti-CHS isolates are identical to one of the anti-CHI clones, B7a. It is possible that CHS and CHI might share a common and strongly-antigenic epitope. Confirmation of this possibility through immunoblot analysis had been hampered, though, by the cross-reactivity of commercially-available polyclonal antibody preparations against M13 phage coat protein with denatured CHS. A more likely explanation is that the bacterial cultures producing the anti-CHS phage particles were contaminated by the B7a anti-CHI phage, which had been isolated in earlier experiments.

## References

- Cain, C. C., D. E. Saslowsky, R. A. Walker and B. W. Shirley (1997). "Expression of chalcone synthase and chalcone isomerase proteins in *Arabidopsis* seedlings." Plant Mol Biol **35**: 377-81.
- Feinbaum, R. L. and F. M. Ausubel (1988). "Transcriptional regulation of the *Arabidopsis thaliana* chalcone synthase gene." Mol Cell Biol **8**: 1985-1992.
- Li, J., T.-M. Ou-Lee, R. Raba, R. G. Amudson and R. L. Last (1993). "*Arabidopsis* flavonoid mutants are hypersensitive to UV-B irradiation." Plant Cell **5**: 171-179.
- Pelletier, M. K., J. R. Murrell and B. W. Shirley (1997). "Characterization of flavonol synthase and leucoanthocyanidin dioxygenase genes in *Arabidopsis*. Further evidence for differential regulation of "early" and "late" genes." Plant Physiol **113**: 1437-45.
- Shirley, B. W., S. Hanley and H. M. Goodman (1992). "Effects of ionizing radiation on a plant genome: analysis of two *Arabidopsis* transparent testa mutations." Plant Cell **4**: 333-47.
- Shirley, B. W., W. L. Kubasek, G. Storz, E. Bruggemann, M. Koornneef, F. M. Ausubel and H. M. Goodman (1995). "Analysis of *Arabidopsis* mutants deficient in flavonoid biosynthesis." Plant J **8**: 659-71.



**Figure 1.** Results of ELISA assays performed to test the specificity of eight phage-scFv's for CHS. Each bar represents the average of readings obtained from two independent experiments. TRX: thioredoxin; GST: glutathione-S-transferase.



**Figure 2.** Sequences of anti-CHS scFv genes and corresponding translations of V<sub>H</sub> regions. The translational enhancer from tobacco etch virus (TEV) and the scFv hinge region are highlighted in gray and yellow, respectively, in all the sequences as points of reference. The various components of the scFv genes that immediately follow the TEV sequence are labeled at the top of the sequence alignment. Each scFv encodes for a V<sub>H</sub> (heavy-chain variable) domain, which is comprised of four framework regions (FR) interspersed with three complementarity determining regions (CDR). The scFv also encodes for a V<sub>L</sub> (light-chain variable) domain, which is invariant among all the scFv's in the particular library used. Between the V<sub>H</sub> and the V<sub>L</sub> domains is a flexible hinge ("linker" sequence) that links the two together. The start codon is the first ATG in the FR1 region of the V<sub>H</sub> domain. Any difference between scFv's in the V<sub>H</sub> domain is shaded in pink. An alignment of the predicted protein products is also shown. The boxed regions correspond to the three CDR's.

Sequence alignment of anti-CHS scFv genes

```

-----TEV non-translated region-----
A7 > ATTTCAATTGGAGAGGACCTCGAGAATTCTCAACACAACATATACAAAACAAACGAATCTCAAGCAATCAAGCATTCTACTTCT
B7b> ATTTCAATTGGAGAGGACCTCGAGAATTCTCAACACAACATATACAAAACAAACGAATCTCAAGCAATCAAGCATTCTACTTCT
D8 > ATTTCAATTGGAGAGGACCTCGAGAATTCTCAACACAACATATACAAAACAAACGAATCTCAAGCAATCAAGCATTCTACTTCT
F7 > ATTTCAATTGGAGAGGACCTCGAGAATTCTCAACACAACATATACAAAACAAACGAATCTCAAGCAATCAAGCATTCTACTTCT

-----TEV non-translated region-----FR1----FR1----
VH >>>
ATTGCAGCAATTTAAATCATTCTTTTAAAGCAAAGCAATTTCTGAAAAATTTTACCATTACGAACGATAGCCATGGCACTCATCT
ATTGCAGCAATTTAAATCATTCTTTTAAAGCAAAGCAATTTCTGAAAAATTTTACCATTACGAACGATAGCCATGGC--CCA---
ATTGCAGCAATTTAAATCATTCTTTTAAAGCAAAGCAATTTCTGAAAAATTTTACCATTACGAACGATAGCCATGGC--CCA---
ATTGCAGCAATTTAAATCATTCTTTTAAAGCAAAGCAATTTCTGAAAAATTTTACCATTACGAACGATAGCCATGGC--CCA---

---FR1-----FR1---FR1-----FR1---FR1---FR1---FR1---FR1---FR1---FR1---FR1---FR1---
TTGGCACAGTCAACGCTAACATCCTGAAGGAAGTGTTCCGGTGTCTGGGGGAGGTGTGGTACGGCCTGGGGGTCCCTGAGACTCTCCT
--GGTGCAG-----CTGGTGA-----GTCTGGGGGAGGTGTGGTACGGCCTGGGGGTCCCTGAGACTCTCCT
--GGTGCAG-----CTGGTGA-----GTCTGGGGGAGGTGTGGTACGGCCTGGGGGTCCCTGAGACTCTCCT
--GGTGCAG-----CTGGTGA-----GTCTGGGGGAGGTGTGGTACGGCCTGGGGGTCCCTGAGACTCTCCT

---FR1---FR1---FR1---FR1---CDR1---FR2---FR2---FR2---FR2---FR2---FR2---FR2---FR2---CDR
GTGCAGCCTCTGGATTACCTTTGATGATTATGGCATGAGCTGGGTCCGCCAAGCTCCAGGGAAGGGGTGGAGTGGGTCTCTGGTATT
GTGCAGCCTCTGGATTACCTTTGATGATTATGGCATGAGCTGGGTCCGCCAAGCTCCAGGGAAGGGGTGGAGTGGGTCTCTGGTATT
GTGCAGCCTCTGGATTACCTTTGATGATTATGGCATGAGCTGGGTCCGCCAAGCTCCAGGGAAGGGGTGGAGTGGGTCTCTGGTATT
GTGCAGCCTCTGGATTACCTTTGATGATTATGGCATGAGCTGGGTCCGCCAAGCTCCAGGGAAGGGGTGGAGTGGGTCTCTGGTATT

---CDR2---CDR2---CDR2---CDR2---CDR2---CDR2---CDR2---CDR2---FR3---FR3---FR3---FR3---FR3---FR3---FR3---FR3---FR
AATTGGAATGGTGGTAGCACAGTTATGCAGACTCTGTGAAGGGCCGATTACCATCTCCAGAGACAACGCCAAGAACTCCCTGTATCT
AATTGGAATGGTGGTAGCACAGTTATGCAGACTCTGTGAAGGGCCGATTACCATCTCCAGAGACAACGCCAAGAACTCCCTGTATCT
AATTGGAATGGTGGTAGCACAGTTATGCAGACTCTGTGAAGGGCCGATTACCATCTCCAGAGACAACGCCAAGAACTCCCTGTATCT
AATTGGAATGGTGGTAGCACAGTTATGCAGACTCTGTGAAGGGCCGATTACCATCTCCAGAGACAACGCCAAGAACTCCCTGTATCT

3---FR3---FR3---FR3---FR3---FR3---FR3---FR3---FR3---CDR3---FR4---FR4---F
GCAAATGAACAGTCTGAGAGCCGAGGACACAGCCGTGTATTACTGTGCAAGAAGGCGGTATGCGTTGGATTATTGGGGCCAAGGTACCC
GCAAATGAACAGTCTGAGAGCCGAGGACACAGCCGTGTATTACTGTGCAAGAAGGCGGTATGCGTTGGATTATTGGGGCCAAGGTACCC
GCAAATGAACAGTCTGAGAGCCGAGGACACAGCCGTGTATTACTGTGCAAGAAGGCGGTATGCGTTGGATTATTGGGGCCAAGGTACCC
GCAAATGAACAGTCTGAGAGCCGAGGACACAGCCGTGTATTACTGTGCAAGAAGGCGGTATGCGTTGGATTATTGGGGCCAAGGTACCC

R4---FR4---FR4---*****Hinge region*****
VL >>>
TGGTACCGTGTGAGAGGGTGGAGGCGGTTCAGGCGGAGGTGGCTCTGGCGGTGGCGGATCGTCTG
TGGTACCGTGTGAGAGGGTGGAGGCGGTTCAGGCGGAGGTGGCTCTGGCGGTGGCGGATCGTCTG
TGGTACCGTGTGAGAGGGTGGAGGCGGTTCAGGCGGAGGTGGCTCTGGCGGTGGCGGATCGTCTG
TGGTACCGTGTGAGAGGGTGGAGGCGGTTCAGGCGGAGGTGGCTCTGGCGGTGGCGGATCGTCTG

```

Translated V<sub>H</sub> Regions

```

A7 > MALIFGTVNANILKEVFGGLGEVWYGLGGP.
B7b, D8, F7> MAQVQLVESGGGVVPRPGSRLRLSCAASGFTFDDYGMSWVRQAPGKGLEWVSGINWNGGSTGYADSVKGRFTISR
NAKNSLYLQMSLRAEDTAVYYCARRRYALDYWGQGTLVTVSR

```

## B. Epitope Mapping of anti-CHI scFv's

In an effort to further characterize the three anti-CHI scFv's, each was tested for reactivity against truncated versions of CHI in immunoblot assays. Using this strategy, we attempted to identify the specific region bearing the unique epitope recognized by each scFv. A series of recombinant plasmids that expressed three C- and three N-terminal CHI truncations fused to TRX was created for these experiments.

### Materials and Methods

#### *Constructs for the Production of Truncated Versions of CHI in Bacteria*

The cloning strategy for the CHI deletion constructs is outlined in Fig. 3. Initially, truncated CHI genes were amplified using the pTRX-CHI plasmid (described in Chapter 2) as template. The primer sets for the amplification of N-terminal truncations were as follows: forward from codon for amino acid (aa) 59: 5'-CGC GGA TCC ACC GTC ATT GGA GTA TAC-3'; aa120: 5'-CGC GGA TCC AAA GTG ACG GAG AAT TGT G-3'; aa180: 5'-CGC GGA TCC AGT ATC CCT GAA ACC G-3'; reverse from aa247: 5'-CCG GTC GAC TCA GTT CTC TTT GGC TAG-3'. The primer set for the amplification of C-terminal truncations included the following: forward from aa1: 5'-CGC GGA TCC CCC GGG CTG CAG-3'; reverse from codon for aa60: 5'-CCG GTC GAC TCA GAC GGT GAA GAT CAC-3'; aa120: 5'-CCG GTC GAC TCA TTT CTC CGA ATA TTG TTG TCC-3'; aa180: 5'-CCG GTC GAC TCA ACT ATC ATC TTT CGA AAA CGC-3'. Each PCR reaction contained 2.5 units of *Pfu* polymerase (Stratagene), 0.5  $\mu$ M of each primer, 0.2 mM dNTP, 10  $\mu$ l of the manufacturer-supplied

10X buffer, and 1 ng of template DNA in a final volume of 100  $\mu$ l. The reactions were performed as follows: 45 sec of  $T_{\text{melt}}=95^{\circ}\text{C}$  followed by 35 cycles of  $T_{\text{melt}}=95^{\circ}\text{C}$  (45 sec),  $T_{\text{anneal}}=58^{\circ}\text{C}$  (45 sec),  $T_{\text{extension}}=72^{\circ}\text{C}$  (60 sec). A 10 min-extension at  $72^{\circ}\text{C}$  was performed as a final step. The PCR products were then purified as described in Chapter 2. The PCR products and approximately 5  $\mu$ g of pET32a plasmid (Novagen) were each digested with 20 units of *Bam*HI (Promega) using manufacturer-supplied buffer at  $37^{\circ}\text{C}$ . After 6 h, the NaCl concentration of each reaction was adjusted to 150 mM. Twenty units of *Sal*I (Promega) were then added, and incubation was continued for an additional 8 h. The digests were subsequently processed and ligations were performed as described for the plant transformation constructs in Chapter 2. A series of six pET32-based constructs, each containing a unique truncated CHI gene, were thus generated in DH10B cells. Plasmid DNA was isolated using the miniprep method of Birnboim and Doly (1979). Approximately 100 ng of each plasmid was then used to transform individual aliquots of 50  $\mu$ l heat-shock competent BL21(DE3) pLysS *E. coli* cells (Novagen) for protein induction experiments as described in Chapter 2.

#### *Expression of Truncated CHI in BL21(DE3)pLysS Cells and Preparation for SDS-PAGE*

For each construct, a flask with 50 ml LB containing 34 mg/L chloramphenicol and 50 mg/L ampicillin was inoculated with BL21(DE3) pLysS carrying the recombinant plasmid. Cultures were grown at  $37^{\circ}\text{C}$  with vigorous shaking until an O.D.<sub>600</sub> reading between 0.6 and 0.8 was obtained (approximately 3 h). The cultures were transferred to room temperature, and expression of the recombinant protein was induced with 0.25 mM

isopropyl- $\beta$ -D-thiogalactopyranoside (IPTG, United States Biochemical) for 4 h with vigorous shaking. At 0 and 4 h, 1 ml of each culture was collected into a microfuge tube and centrifuged at 16,000 x g for 5 min to pellet the cells. Cells were resuspended in 400  $\mu$ l cold lysis buffer (20 mM Tris, 100 mM NaCl, pH 8.0) and kept on ice for 5 min. The cells were then pelleted again by centrifugation at 16,000 x g for 5 min. The supernate was discarded and the cell pellets were placed at -80°C for approximately 30 min. The frozen cell samples were thawed and then 100  $\mu$ l lysis buffer, 1  $\mu$ l phenylmethanesulfonylfluoride (PMSF, Sigma Chemicals), 0.1  $\mu$ l 40 mg/ml DNase (Sigma Chemicals), and 1  $\mu$ l 1M MgCl<sub>2</sub> were added to each sample. The samples were then incubated on ice until the lysates were no longer viscous (30-40 min). Following centrifugation at 16,000 x g for 10 min the soluble fractions were transferred to new microfuge tubes. The insoluble protein pellets were each resuspended in 100  $\mu$ l lysis buffer. Five microliters of these soluble or insoluble protein preparations were mixed with 2X gel loading buffer (4% SDS, 10%  $\beta$ -mercaptoethanol, 125 mM Tris-HCl, pH 6.8, 20% glycerol, 0.05% bromophenol blue), and then boiled for 15 min just before fractionation by SDS-PAGE.

#### *Analysis of Recombinant Proteins by SDS-PAGE*

Boiled samples were loaded into wells of a 10% SDS-PAGE gel. Four microliters of pre-stained protein standard (SeeBlue Plus 2, Novex) was also loaded. Electrophoresis and subsequent transfer to 0.2  $\mu$ m nitrocellulose membranes were performed as described by Cain et al. (1997), with the following modifications. For the immunoblot probed with

affinity-purified IgY-anti-CHI, the antibody was diluted 1:2000 in PBS containing 2% (v/v) Carnation powdered skim milk (MPBS) (Saslowky and Winkel-Shirley, *in press*), and the secondary antibody, horse radish peroxidase (HRP)-conjugated rabbit-anti-IgY, was diluted 1:60,000 in 2% MPBS. For the immunoblots probed with D10 or E7, the membranes were initially probed with  $10^8$  phage particles/ml in 2% MPBS at 4°C overnight. The succeeding steps were performed as described previously (Cain et al. 1997), using a rabbit-anti-M13 IgG (Sigma Chemicals) secondary antibody, diluted 1:5000 in 2% MPBS, followed by an HRP-conjugated goat-anti-rabbit (Jackson Immunoresearch) tertiary antibody diluted 1:10,000 in 2% MPBS. The immunoblot probed with IC5 was processed similarly, except that  $10^6$  phage particles/ml were used as primary probe and the tertiary antibody was diluted 1:5000. For all immunoblots, HRP activity was detected using the West Dura Detection System (Pierce Chemicals) according to manufacturer's instructions.

#### *Generation of Hydrophilicity Plot*

A hydrophilicity plot was generated for the full-length TRX-CHI protein sequence using the Protein Sequence Analysis program of Lasergene (DNA Star).

#### Results and Discussion

To determine the CHI regions that are recognized by specific scFv's, a series of CHI truncations was first created. Each truncated gene encoded amino acids 1-60, 1-120, 1-180, 180-247, 120-247, or 60-247. Together, these represent three C- and three N-



terminal truncations of the 247-amino acid CHI protein (Fig. 4A). These truncations were fused to the 3' end of the TRX gene in pET32a. With the exception of the clone expressing amino acids 1 to 120, all the truncated versions were successfully expressed (Fig. 4B). In addition, the relative migration rates of the induced proteins on SDS-PAGE gels were consistent with their predicted sizes (TRX-CHI 1-60: 24.5 kD, TRX-CHI 1-120: 31.2 kD, TRX-CHI 1-180: 37.8 kD, TRX-CHI 180-247: 25.0 kD, TRX-CHI 120-247: 31.6 kD, TRX-CHI 59-247: 38.4 kD), although their migrations were slightly retarded relative to the protein standards. This inconsistency, however, was also observed with the 45 kD full-length TRX-CHI, which aligns with the 50 kD protein standard (Fig. 4C).

To determine if epitopes on the truncations would be recognized by an affinity-purified polyclonal IgY-anti-CHI antibody preparation, an immunoblot assay was performed as shown in Fig. 4C. Relatively equivalent amounts of protein, based on staining, from the soluble and insoluble fractions of the bacterial lysate for each truncation were included because not all the truncations partitioned preferentially into the soluble fraction. In this assay, CHI fragments are recognized in both the soluble and insoluble fractions of crude lysates from bacteria expressing any of the N-terminal truncations. The signal intensities do not appear to vary among the N-terminal truncations, suggesting that the epitopes recognized in the smallest CHI region represented (amino acids 180-247) may comprise the bulk of the epitopes recognized by the polyclonal antibodies in the larger N-terminal peptides. Among the C-terminal truncations, a strong signal was detected from the CHI fragment in the insoluble fraction of bacteria expressing TRX-CHI 1-180. The CHI fragments in the soluble fraction of

TRX-CHI 1-60 and insoluble fraction of TRX-CHI 1-120 also appear to be recognized by the polyclonal antibody preparation, although the signals are very faint due to lower expression.

Interestingly, all the N-terminal truncations appeared to be relatively soluble, while the C-terminal truncations were only partially soluble (TRX-CHI 1-60), insoluble (TRX-CHI 1-180), or not expressed at detectable levels (TRX-CHI 1-120) (Fig. 4B). It is possible that a structural feature within the C-terminal portion is responsible for the solubility of the N-terminal truncated versions of CHI. Consistent with this possibility is the presence of a major hydrophilic stretch at the C terminus, approximately 30 amino acids long (Fig. 5). This stretch is common among all the N-terminal truncations, and could possibly comprise the bulk of the minimal region required for solubility and antibody recognition, as corroborated by the similar signal intensities in the immunoblot shown in Fig. 4C. Taken together, these results suggest that despite the liberal distribution of antigenic regions throughout CHI as predicted by the antigenicity plot (Fig. 5), most of the readily-recognizable epitopes (i.e. more exposed) are located between residues 180 and 247. It is also possible that the C-terminal truncations are less stable, and therefore do not accumulate to levels that could be readily detected by antibodies in immunoblots.

Immunoblot assays were performed using the scFv's B7a, D10, and E7 in order to determine the CHI regions recognized by these clones as shown in Fig. 6. A summary of the results is provided in Table 1. It is expected that the scFv's will recognize a single well-defined epitope composed of at least four residues. Whereas all three clones recognized the TRX-CHI 1-180 truncation, B7a also recognized TRX-CHI 59-247.

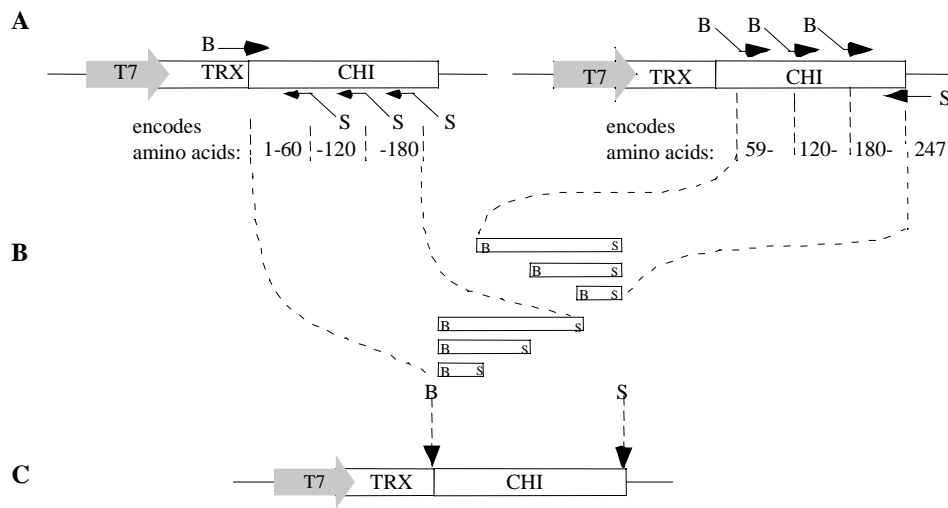
Surprisingly, D10, which had been shown to cross-react with TRX in previous experiments described in Chapter 2, did not bind to all the fusion proteins. Moreover, in all cases, other truncations, which contain the same putative epitopes, were not detected by the same scFv. For instance, E7 did not recognize TRX-CHI 120-247 and 59-247, although both overlap with TRX-CHI 1-180 at the region between residues 120 and 180. Because E7 also did not recognize TRX-CHI 1-60, it is possible that the epitope recognized by E7 is actually between residues 1 and 60, but is only accessible when expressed as part of the larger peptide, TRX-CHI 1-180. Similarly, B7a only weakly binds TRX-CHI 1-180 though it overlaps with the region between residues 59 and 120 on TRX-CHI 59-247, the putative location of the epitope recognized by B7a deduced from its lack of reactivity with TRX-CHI 120-247 and 180-247. TRX-CHI 1-120 was also expected to react with B7a based on the scFv's recognition of both TRX-CHI 1-180 and 59-247, but there was insufficient TRX-CHI 1-120 protein in the sample to obtain any conclusive result. B7a may also only recognize the epitope when it is expressed as part of a larger CHI peptide. From these experiments, it appears that epitope recognition is dependent on the presence of a contiguous CHI region at the C-terminal side for B7a and at the N-terminal side for E7. It is interesting to note that unlike the polyclonal IgY, which detected TRX-CHI 59-247 in both the soluble and insoluble fractions, B7a recognized the truncation only in the insoluble fraction. This suggests that epitope presentation may be different between soluble and insoluble fractions, although it is not clear how this could happen considering that the fractionation was done under denaturing conditions. These experiments do seem to differentiate B7a from the other scFv's in binding specificity, which could partially account for the different phenotypic effects of

these clones in transgenic plants. It is possible that all the epitopes recognized by the three scFv's are within structural domains, but that the epitope recognized by B7a recognizes is in a region in which binding has a more direct impact on flavonoid metabolism, perhaps by affecting CHI structure and/or inhibiting it from interacting with other enzymes.

## References

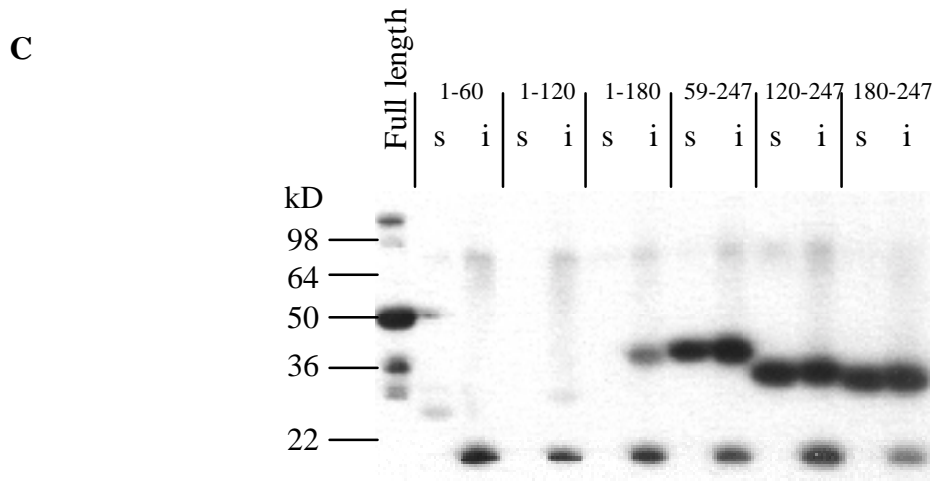
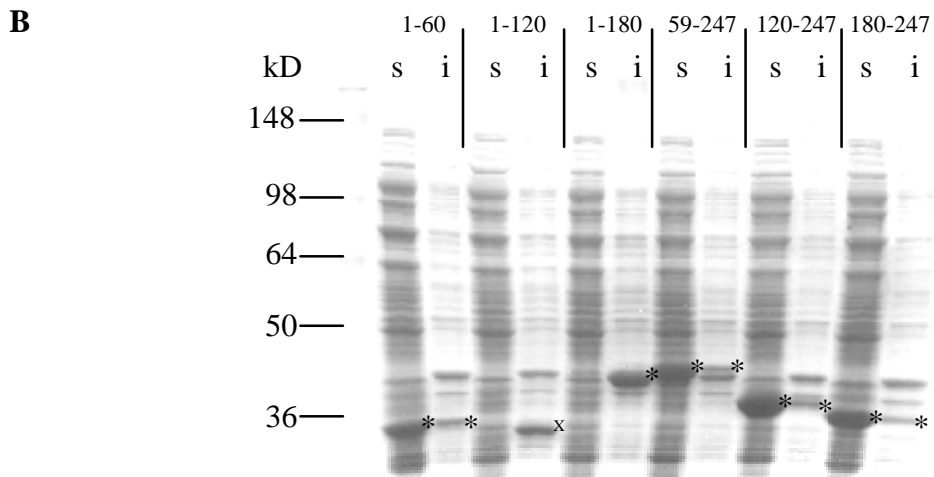
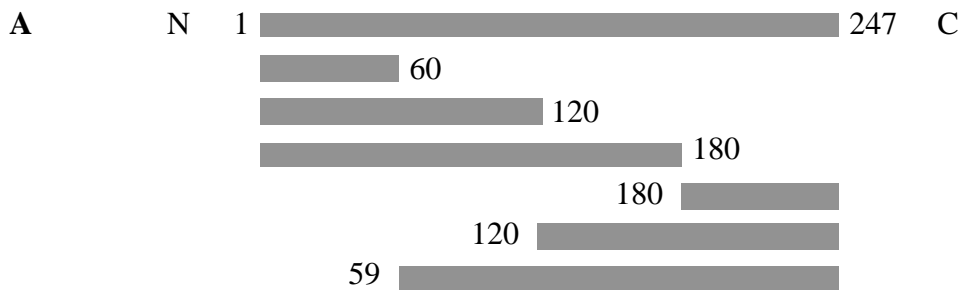
- Birnboim, H. C. and J. Doly (1979). "A rapid alkaline extraction procedure for screening recombinant plasmid DNA." Nucleic Acids Res **7**: 1513-23.
- Cain, C. C., D. E. Saslowsky, R. A. Walker and B. W. Shirley (1997). "Expression of chalcone synthase and chalcone isomerase proteins in *Arabidopsis* seedlings." Plant Mol Biol **35**: 377-81.
- Saslowsky, D. and B. S. J. Winkel-Shirley (2001). "Localization of flavonoid enzymes in *Arabidopsis thaliana* roots." Plant J *in press*.

**Figure 3.** Schematic of cloning strategy for truncated versions of CHI in the pET32a vector. A. Relative positions of priming sites on pTRX-CHI plasmid template. Each primer contained a *Bam*HI (B) or *Sal*I (S) site. B. PCR products with desired terminal restriction sites. C. pTRX-CHI shown with *Bam*HI and *Sal*I cloning sites flanking the full-length CHI gene.

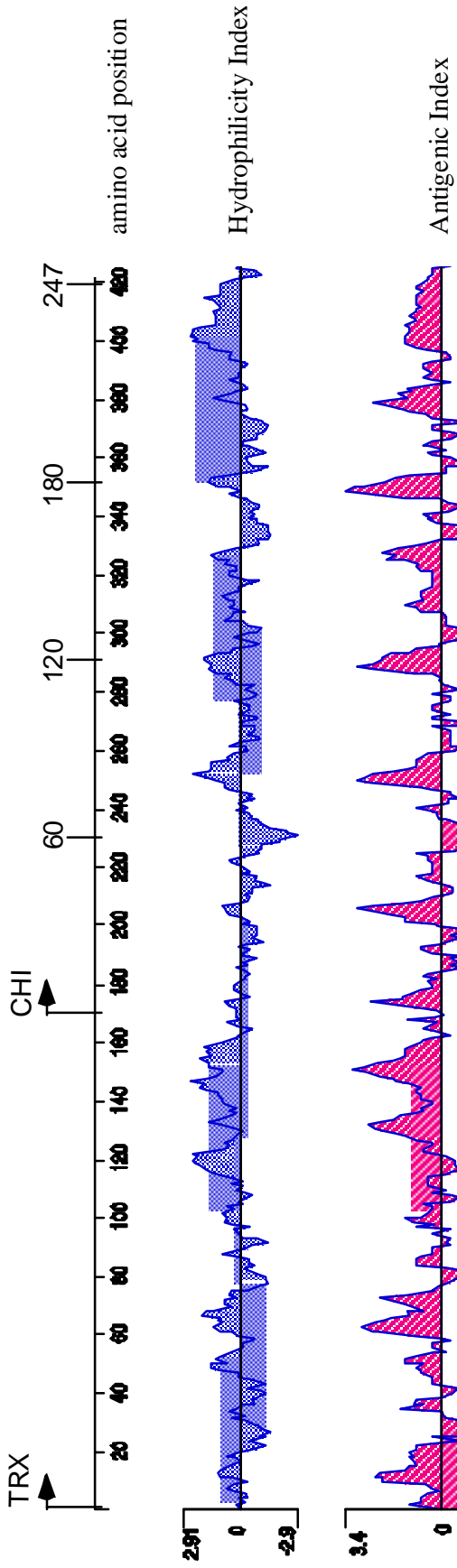


**Figure 4.** Expression of truncated versions of CHI in *E. coli*. A. Schematic showing sizes of truncations relative to the full-length CHI. B. Coomassie-stained 10% SDS-PAGE gel loaded with soluble (s) or insoluble (i) fractions from each IPTG-induced bacterial culture transformed with the CHI truncation indicated at the top of the gel. Induced proteins are labeled with an asterisk. A strong band from an unknown protein is present in the soluble fraction of TRX-CHI 1-120 marked with an “X”. C. Immunoblot of bacterial proteins transferred to 0.2  $\mu$ m nitrocellulose membrane after fractionation by 10% SDS-PAGE. Membrane was probed with polyclonal IgY-anti-CHI antibody. Sample loading is the same as in B, except that the full-length CHI is included.



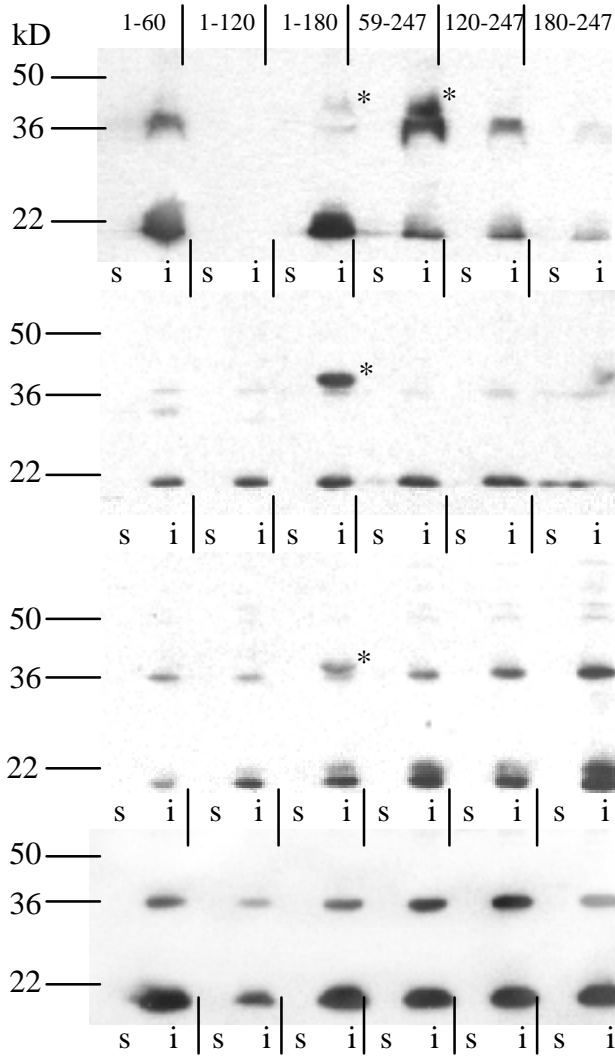


**Figure 5.** Hydrophilicity and antigenic indices of TRX-CHI. Numbers at the bottom of the ruler reflect the amino acid position in the TRX-CHI fusion protein. Numbers at the top refer to amino acid positions within CHI, with the first methionine residue of CHI designated as position #1.



**Figure 6.** Immunoblots showing reactivities of each scFv to truncated versions of CHI. Numbers at the top of the first blot indicate the CHI region expressed by the bacteria from which the soluble (s) and insoluble (i) fractions were extracted. Negative control (-): membrane was probed with the 2° and the 3° antibody preparations used for the immunoblots probed with scFv's. Asterisks indicate the bands corresponding to the CHI fragments that are recognized by the scFv.

Primary antibody:



**Table 1.** The relative signal intensities from truncated versions of CHI recognized by the scFv's B7a, D10, or E7 in an immunoblot assay (Fig. 4).

Primary antibody	Residues expressed in truncated CHI					
	1-60	1-120	1-180	59-247	120-247	180-247
B7a	-	-	+/-	+++	-	-
D10	-	-	+++	-	-	-
E7	-	-	+++	-	-	-
Polyclonal IgY	-	-	+/-	+++	+++	+++

### C. Segregation Analysis to Identify Homozygous Transgenic Plants

In analyzing the effects of the expression of a transgene among several transgenic lines, it is important to minimize the variability in gene dosage within each line.

Heterozygous transgenic plants will generally not express the transgene at the same level as corresponding homozygotes. To reduce the effect of this variability, seeds from one transgenic line can be pooled and subjected to recurrent selection. Such a procedure, however, may require the passage of several generations before a relatively homozygous population is established, even for self-pollinated species. Selection pressure has to be applied for at least eight generations to achieve around 98% homozygosity. Another way to obtain a homozygous population is through single-seed descent analysis of the progeny of  $T_0$  plants (plants that bear the first transgenic seeds). Each seedling at the  $T_1$  stage is heterozygous for the transgene(s) integrated into its chromosome. In the case of one or more transgenes inserted at a single site, the resulting  $T_2$  progeny of each  $T_1$  plant, will therefore be a “segregating” population, in which 50% will be heterozygous and 25% will be homozygous for the transgene. The progeny of individual  $T_2$  plants can then be subjected to segregation analyses.  $T_3$  populations that do not appear to segregate for the transgene (i.e. all seedlings survive under drug selection) are considered putatively homozygous. The possibility remains that multiple unlinked transgenes are present, complicating analysis. However, the availability of homozygous populations facilitates comparisons among different transgenic lines because phenotypic variation arising from genetic variability is reduced.

### Identification of Homozygous Populations of scFv-expressors

The scheme for identification of putatively homozygous transgenic populations is illustrated in Fig. 7. After the identification of a minimum of 10 transformed lines (each representing an independent transformation event) for each of the three anti-CHI scFv genes as described in Chapter 2, T<sub>2</sub> seeds from each line were collected and surface-sterilized as described previously (Kubasek et al. 1992). For each line, approximately 100 seeds were scattered on sterilized 70 mm No. 5 Whatman filter disks that had been pre-moistened with sterile MS medium. Each filter was then placed on MS-agar plates containing 50 mg/L kanamycin (for selection of transformed plants) and 200 mg/L timentin (to eliminate any remaining *Agrobacterium*). The plates were sealed with parafilm, wrapped in foil, and stored at 4°C for 2 d for vernalization. They were subsequently transferred to a 22°C incubator under continuous white light (120 µE). Sixteen survivors from each plate, which were either homozygous or heterozygous for the transgene(s), were transferred to individual 2 ½" x 3 ½" pots after 12 d of selection. These were grown to maturity under 16 h days at 120 µE, 22°C. T<sub>3</sub> seeds from each plant were pooled and subjected to another round of kanamycin selection on MS-agar plates. Plates that had 100% survivorship after 12 d of selection were considered putatively homozygous. All seedlings from such plates were subsequently transferred to 5" x 5" pots and grown to maturity as described above. The resulting T<sub>4</sub> seeds from each pot were pooled and used for further analysis.



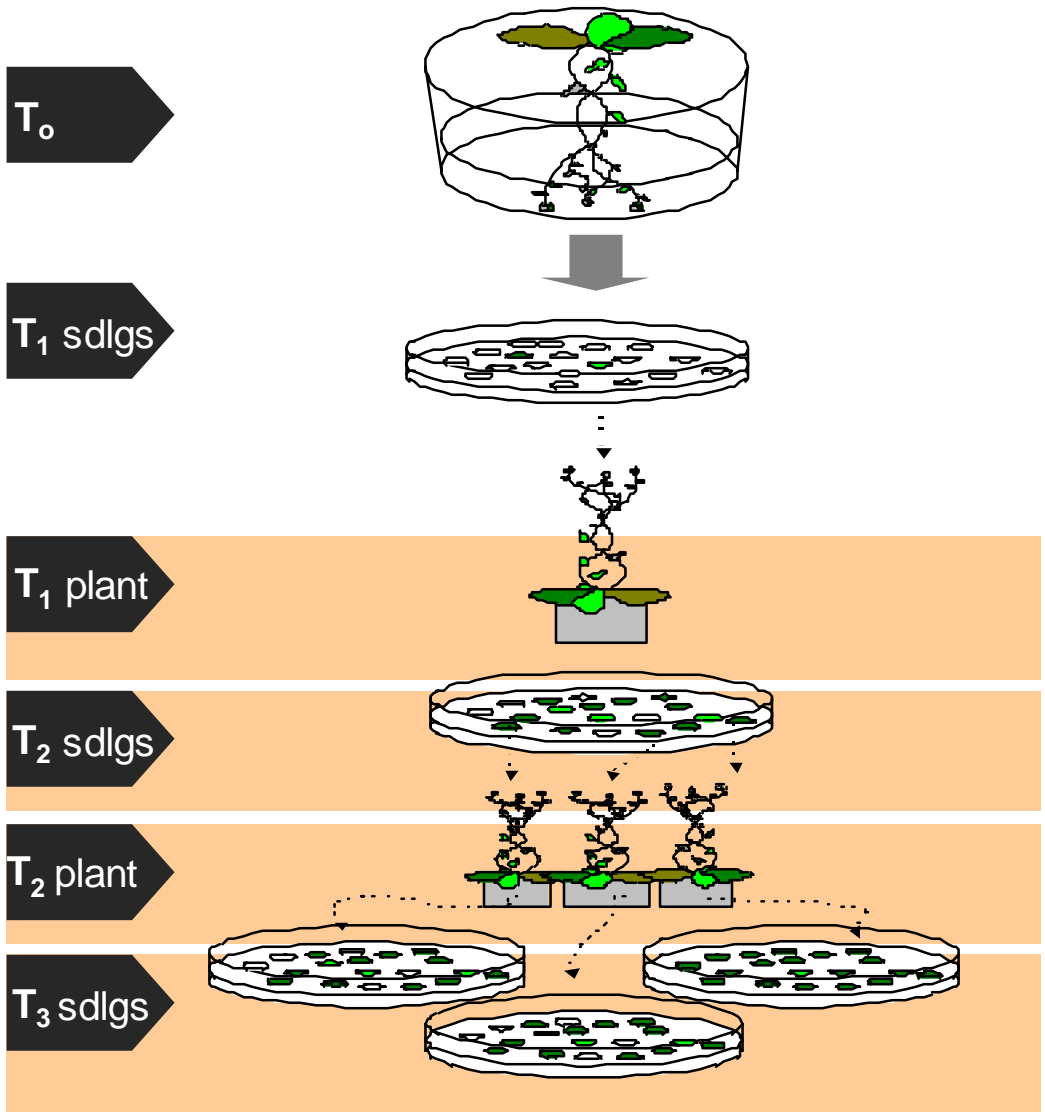
## Results and Discussion

A total of 36 independent transformed lines were identified for the three scFv genes described in Chapter 2. Each line was subjected to repeated rounds of kanamycin selection as it was advanced to the T<sub>4</sub> generation. In the process, establishment of putatively homozygous populations of most lines was accomplished. Table 2 summarizes the results of the segregation analyses. Listed in the table are the percentages of survivors among individual T<sub>3</sub> populations descended from single T<sub>1</sub> seeds. In this analysis, a transgenic line resulting from integration at a single site will have a segregating T<sub>3</sub> population that will be 25% homozygous for the kanamycin resistance gene (RR), 25% homozygous susceptible (rr), and 50% heterozygous (Rr). Putatively homozygous populations have perfect or nearly-perfect survival rates under kanamycin selection. In the table, these are identified in bold print. Not all lines had single gene insertions, however, because varying genotypic ratios could be inferred from the results of the selection process that did not conform to simple Mendelian segregation for a single locus. This was confirmed by Southern blot analysis of three transgenic lines, B7a-1, B7b-2, and B7b-1, the line with an altered flavonoid content. Multiple transgenes were detected in all three. Thus, a population of T<sub>3</sub> seedlings that completely survives kanamycin selection is not necessarily genotypically homozygous. Nonetheless, genotypic variability is progressively diminished in the process of repeated selection. Most of the critical analyses performed in this project utilized pooled T<sub>4</sub> seeds from each line. Since these seeds were the result of three consecutive rounds of kanamycin selection, genetic variability within each line should have been significantly reduced, regardless of the multiplicity of transgene insertion.

Reference

Kubasek W. L., B. W. Shirley, A. McKillop, H. M. Goodman, W. Briggs and F. M. Ausubel (1992). "Regulation of flavonoid biosynthetic genes in germinating *Arabidopsis* seedlings." Plant Cell **4**:1229-1236

**Figure 7.** Schematic of strategy for the identification of putative homozygous lines.  $T_0$  refers to the plant used in the transformation experiment, and is thus depicted as an inverted plant with inflorescences submerged in *Agrobacterium* infiltration medium. Gray discs in the Petri plates represent transgenic seedlings that survive selection on kanamycin.



**Table 2.** Identification of putatively homozygous T<sub>3</sub> populations by segregation analysis.

D10 <sup>a</sup> -	1 <sup>b</sup>	2	3 <sup>c</sup>	4	5	6	7	8	9	10
A <sup>d</sup>	-	0		91	17	-	-	88	-	-
B	<b>100<sup>e</sup></b>	0		-	64	-	80	78	-	-
C	79	0		-	98	-	-	92	-	-
D	80	0		-	-	-	94	-	90	-
E	<b>99</b>	0		-	-	-	30	75	81	-
F	-	3		-	0	-	78	93	77	-
G	-	0		-	-	-	61	75	77	-
H	-	0		-	-	-	-	<b>99</b>	<b>100</b>	-
I	-	0		72	<b>100</b>	-	71	-	-	-
J	-	74		-	95	-	<b>97</b>	79	-	-
K	-	75		-	79	-	-	77	-	19
L	-	2		<b>99</b>	-	-	79	71	-	-
M	-	0		-	-	<b>99</b>	80	-	-	-
N	-	0		75	74	8	70	83	74	96
O	-	0		3	-	4	63	-	93	-
P	-	-		25	-	2	-	-	<b>100</b>	<b>100</b>

E7-	1	2	3	4	5	6	7	8	9	10
A	-	<b>98</b>	0	78	0	<b>100</b>	<b>98</b>	64	-	0
B	-	91	0	<b>100</b>	0	-	<b>98</b>	78	90	<b>100</b>
C	-	94	0	<b>100</b>	-	0	94	-	-	-
D	<b>98</b>	<b>98</b>	0	-	-	75	96	0	-	-
E	-	0	-	-	76	-	94	-	-	-
F	<b>99</b>	94	-	-	-	-	94	-	-	-
G	-	95	-	-	0	-	-	-	-	-
H	94	88	-	73	<b>99</b>	-	49	-	-	-
I	97	0	-	-	-	-	-	-	96	-
J	-	0	-	86	-	-	-	-	-	-
K	-	68	-	-	92	-	-	-	-	-
L	-	-	-	80	-	-	97	-	-	-
M	-	0	-	-	-	-	-	-	-	-
N	-	-	-	74	87	-	-	-	-	-
O	-	-	-	<b>99</b>	<b>100</b>	-	-	-	-	-
P	-	-	-	77	75	74	-	-	<b>100</b>	-

**Table 2** (continuation).

C5-	1 <sup>c</sup>	2	3	4	5	6 <sup>c</sup>	7	8	9	10
A		-	-	<b>100</b>	<b>100</b>		-	-	-	19
B		-	75	-	85		-	-	-	-
C		-	-	-	0		-	-	75	-
D		0	-	-	-		-	-	-	76
E		-	-	-	79		-	<b>97</b>	79	29
F		0	8	94	18		-	78	-	-
G		0	-	-	72		61	-	-	-
H		-	-	-	74		-	-	-	42
I		-	-	-	-		-	-	-	40
J		0	-	-	-		73	-	-	12
K		-	-	-	-		-	-	94	71
L		0	-	-	-		<b>100</b>	-	-	58
M		-	-	77	-		-	81	75	71
N		-	-	-	-		-	-	-	-
O		-	-	-	-		<b>98</b>	-	<b>99</b>	43
P		-	-	-	-		95	-	-	-

B7-	1	2	4	5	8	D8-	1	4	5	7
A	-	-	-	73	65		92	89	-	-
B	-	-	-	-	-		-	-	-	-
C	75	-	-	<b>99</b>	-		-	0	43	-
D	75	-	25	-	-		-	-	50	91
E	-	-	-	-	27		<b>99</b>	<b>98</b>	69	-
F	75	-	-	75	82		-	0	-	<b>100</b>
G	-	-	-	80	95		-	-	-	-
H	-	-	69	97	96		70	-	52	-
I	-	-	-	-	-		92	97	42	96
J	75	-	81	60	<b>100</b>		-	86	58	-
K	75	-	-	-	-		-	-	-	-
L	-	-	75	-	-		97	0	-	-
M	-	96	-	87	94		-	-	-	-
N	-	<b>96<sup>f</sup></b>	65	-	-		-	<b>99</b>	46	-
O	-	-	-	<b>100</b>	-		-	-	-	-
P	-	-	-	-	-		-	13	25	-

<sup>a</sup>D10, E7, C5, B7, D8 are the scFv gene names. C5, B7, and D8 sequences are identical.

In the text, C5 is referred to as B7a, while B7 and D8 are referred to as B7b.

<sup>b</sup>Each of the numbers at the top of each matrix refers to a particular T<sub>1</sub> ancestor, representing a unique transformation event involving the scFv gene specified at the top-left box of each matrix.

<sup>c</sup>None of the T<sub>2</sub> progeny of this T<sub>1</sub> ancestor survived selection.

<sup>d</sup>Letters A to P refer to the T<sub>2</sub> progeny of each T<sub>1</sub> ancestor.

<sup>e</sup>Numbers within the matrix represent percentages of kanamycin-selection survivors in each unique T<sub>3</sub> population. Putatively homozygous populations are identified in bold print.

<sup>f</sup>Phenotypically-altered line; referred to in the text as line B7b-1.

“-” T<sub>3</sub> population was not screened.

#### D. HPLC Analyses of Seedlings After Exposure to UV-B

Light in the UV-B range has long been known to induce flavonoid biosynthesis. Early studies using parsley cell cultures, for instance, showed that exposure to UV-B resulted in increased levels of CHS transcripts (Hahlbrock and Scheel 1989). Similarly, in *Arabidopsis*, such treatment was seen to induce a coordinated increase in transcripts of genes encoding phenylpropanoid and flavonoid enzymes (Kubasek et al. 1992). In addition, there have been reports demonstrating increased levels of flavonoid pigments in *Arabidopsis* upon exposure to UV-B (Jordan et al. 1998; Schnitzler et al. 1996).

In an effort to enhance the potential differences in flavonoid composition between wild-type and transgenic lines expressing an anti-CHI scFv, etiolated and white light-grown seedlings from wild-type or transgenic lines were subjected to various durations of UV-B exposure, followed by HPLC analysis to visualize the resulting changes in flavonoid composition. Whereas wild-type seedlings were predicted to have increased flavonoid end-products upon UV-B treatment, anti-CHI scFv expressors might not accumulate as much end-products due to impairment of CHI in terms of its catalytic efficiency, ability to interact with other enzymes of the pathway, or even its structural stability (i.e. increased rate of degradation). On the other hand, if the binding of scFv to CHI somehow resulted in enhanced metabolic efficiency, an increase in flavonoid end-products would be observed.



## Materials and Methods

### *Growth Conditions and UV-B Treatment of Seedlings*

Seeds were surface-sterilized and vernalized as described in Appendix C, except that the MS medium used in this experiment did not contain sucrose in order to start from the lowest flavonoid baseline possible prior to induction. Light-grown seedlings were allowed to develop for 7, 11, or 14 d under continuous light (120  $\mu$ E, 22°C), then exposed to 100 to 200 mW/m<sup>2</sup> UV-B (FS20T12-UVB, National Biological, Twinsburg OH) for up to 96 h. Fifteen seedlings were harvested at various time points from 0 to 96 h after UV-B exposure. Etiolated seedlings were grown for 4, 5, or 6 days in darkness at 22°C, then exposed to UV-B and harvested as described above. Because 5-day and 6-day dark-grown seedlings started dying after 48 and 24 h of UV-B exposure, respectively, not all time points shown for 4-day dark grown-seedlings in Fig. 10 could be included for the 5 and 6-day dark-grown groups.

### *HPLC Analysis of Flavonoid Content*

Methanolic extracts of seedlings were prepared and analyzed by HPLC as described by Saslowsky et al. (2000), except that 15 rather than 30 seedlings were used for each sample.

## Results and Discussion

As an initial test to determine the suitability of UV-B treatment for enhancing differences in flavonoid biosynthesis, three transgenic lines (D10-9P, B7b-1, and pBIRT5-10), wild type, and a CHS-null mutant (*tt4*) were grown for 11 d under

continuous white light. The seedlings were then exposed to UV-B for up to 24 h. The treatment did not appear to increase flavonoid levels in any of the plants even after 24 h of exposure (Fig. 8). In fact, flavonoid levels were somewhat reduced at 4.5 h. Interestingly B7b-1, which consistently exhibited reduced flavonol levels at the 5 day-old seedling stage, had accumulated nearly wild-type levels of these compounds by day 11 of development. However, the relative levels of different flavonols in this line remained altered relative to wild-type regardless of length of UV-B exposure.

Because this experiment did not demonstrate any obvious enhancement of differences in flavonoid composition between transgenic lines and wild-type, a series of optimization experiments was performed using wild-type seedlings to determine the ideal conditions for UV-B induction of flavonoid biosynthesis. Seedlings grown for 7, 11, or 14 d under continuous white light were subsequently exposed to UV-B for up to 96 h. The flavonoid compositions of these plants at various time points after UV-B exposure were again examined by HPLC analysis, as shown in Fig. 9. In this analysis, however, no samples exposed to UV-B for just 4.5 h were included because the previous assay (Fig. 8) showed that this was too short an interval to see any induction effect by UV-B. Surprisingly, prolonging the duration of UV-B exposure to a maximum of 96 h did not appear to induce flavonoid biosynthesis in seedlings at different developmental stages.

Finally, the inducibility of flavonoid production by UV-B was examined in etiolated seedlings. Wild-type seedlings grown for 4, 5, or 6 days in darkness were exposed to UV-B for up to 96 h. Fig. 10 shows the flavonoid compositions of these plants at various time points, revealing no induction of flavonoid biosynthesis, except for the 4-day dark-grown seedlings which showed a third flavonol peak 48 h after exposure.

However, the experiment did show a correlation between the number of days of germination in darkness and sensitivity to subsequent UV-B exposure. Whereas seedlings grown for 4 d in darkness survived 96 h of UV-B treatment, the 5 day-old seedlings survived only 48 h of exposure, while the 6 day-old seedlings died after 24 h of exposure.

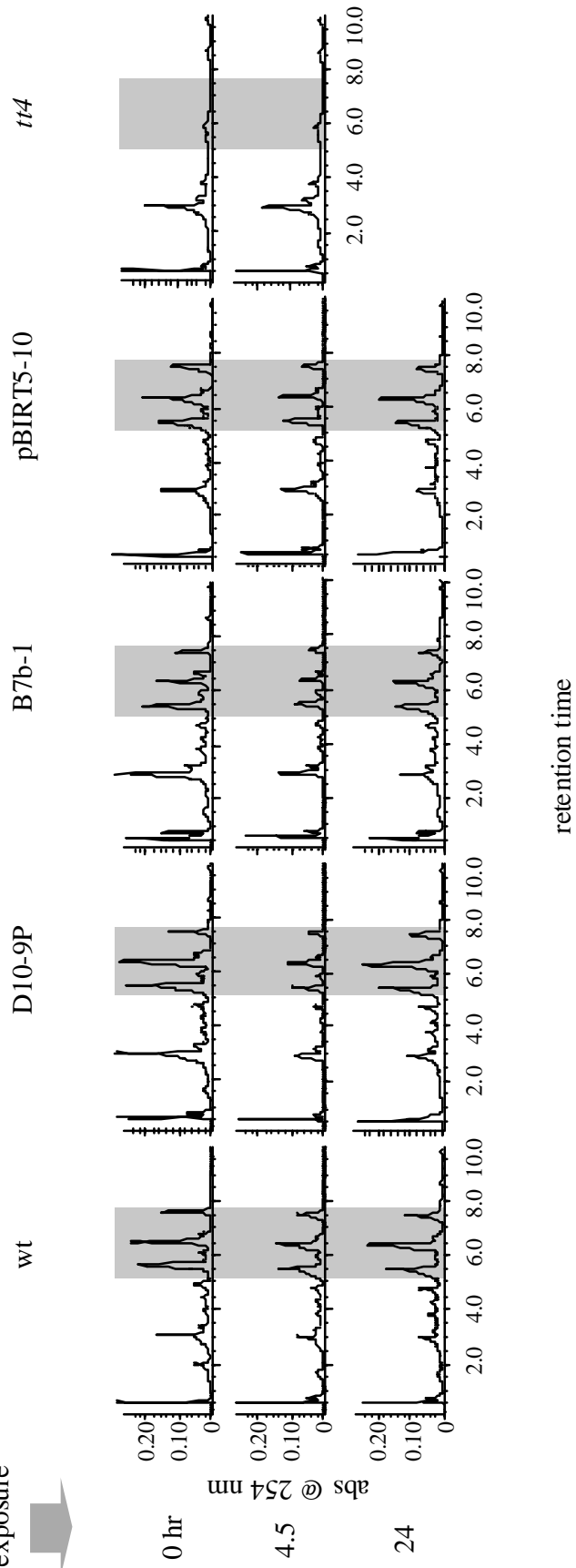
After failing to detect any induction effect by UV-B in either etiolated or white light-grown seedlings, we decided to monitor flavonoid profiles during the course of normal seedling development under continuous white light. This was performed to identify the approximate time period that showed the greatest difference in flavonoid composition between wild-type and transgenic lines. The results of this experiment are presented in Chapter 2.

## References

- Hahlbrock, K. and D. Scheel (1989). "Physiology and molecular biology of phenylpropanoid metabolism." In: *Annu Rev Plant Physiol Plant Mol Biol.* **40**: 347-369.
- Jordan, B. R., P. E. James and S. A. H.-Mackerness (1998). "Factors affecting UV-B-induced changes in *Arabidopsis thaliana* L. gene expression: the role of development, protective pigments and the chloroplast signal." *Plant Cell Physiol* **39**: 769-78.
- Kubasek W. L., B. W. Shirley, A. McKillop, H. M. Goodman, W. Briggs and F. M. Ausubel (1992). "Regulation of flavonoid biosynthetic genes in germinating *Arabidopsis* seedlings." *Plant Cell* **4**:1229-1236.
- Saslowky, D. E., C. D. Dana and B. Winkel-Shirley (2000). "An allelic series for the chalcone synthase locus in *Arabidopsis*." *Gene* **255**: 127-138.
- Schnitzler, J. P., T. P. Jungblut, W. Heller, M. Kofferlein, P. Hutzler, U. Heinzmann, E. Schmelzer, D. Ernst, C. Langebartels and H. Sandermann Jr (1996). "Tissue localization of UV-B screening pigments and of chalcone synthase mRNA in needles of scots pine seedlings." *New Phytol* **132**: 247-258.

**Figure 8.** HPLC profiles of flavonoids present in 11 day-old light-grown seedlings exposed to UV-B. Seedlings were grown in continuous white light for 11 d and subsequently exposed to 100-200 mW/m<sup>2</sup> UV-B for 4.5 or 24 h. Wt: wild-type; *tt4*: CHS-null mutant; D10-9P and B7b-1: transgenic plants expressing anti-CHI scFv's; pBIRT5-10: transgenic plant with no scFv gene.

Length of  
UV-B  
exposure



**Figure 9.** HPLC profiles of flavonoids in 7, 11, and 14 d-old light-grown plants exposed to UV-B light. Wild-type seedlings were grown in continuous white light for 7, 11, or 14 d and subsequently exposed to 100-200 mW/m<sup>2</sup> UV-B for 24, 48, or 96 h.

Length of UV-B exposure



0 hr

24

48

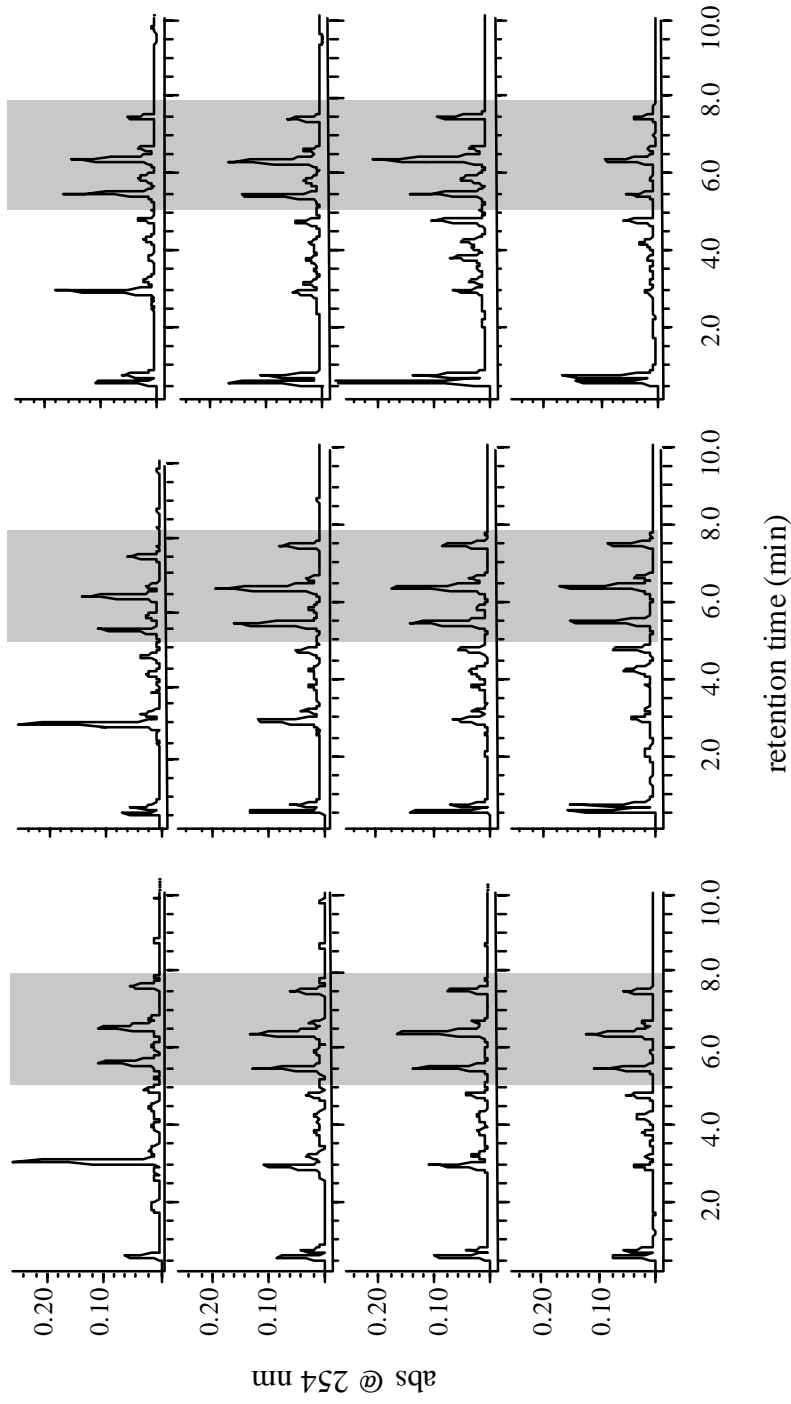
96

Seedling age at time of initial UV-B exposure:

7 d

11 d

14 d





**Figure 10.** HPLC profiles of flavonoids in 4, 5, or 6 d-old etiolated seedlings exposed to UV-B light. Wild-type seedlings were grown in darkness for 4, 5, or 6 d, and subsequently exposed to 100-200 mW/m<sup>2</sup> UV-B for 24, 48, or 96 h. The 5 and 6 day-old seedlings did not survive exposure to UV-B for 96 and 48 h, respectively.

Length of UV-B exposure



0 hr

24

48

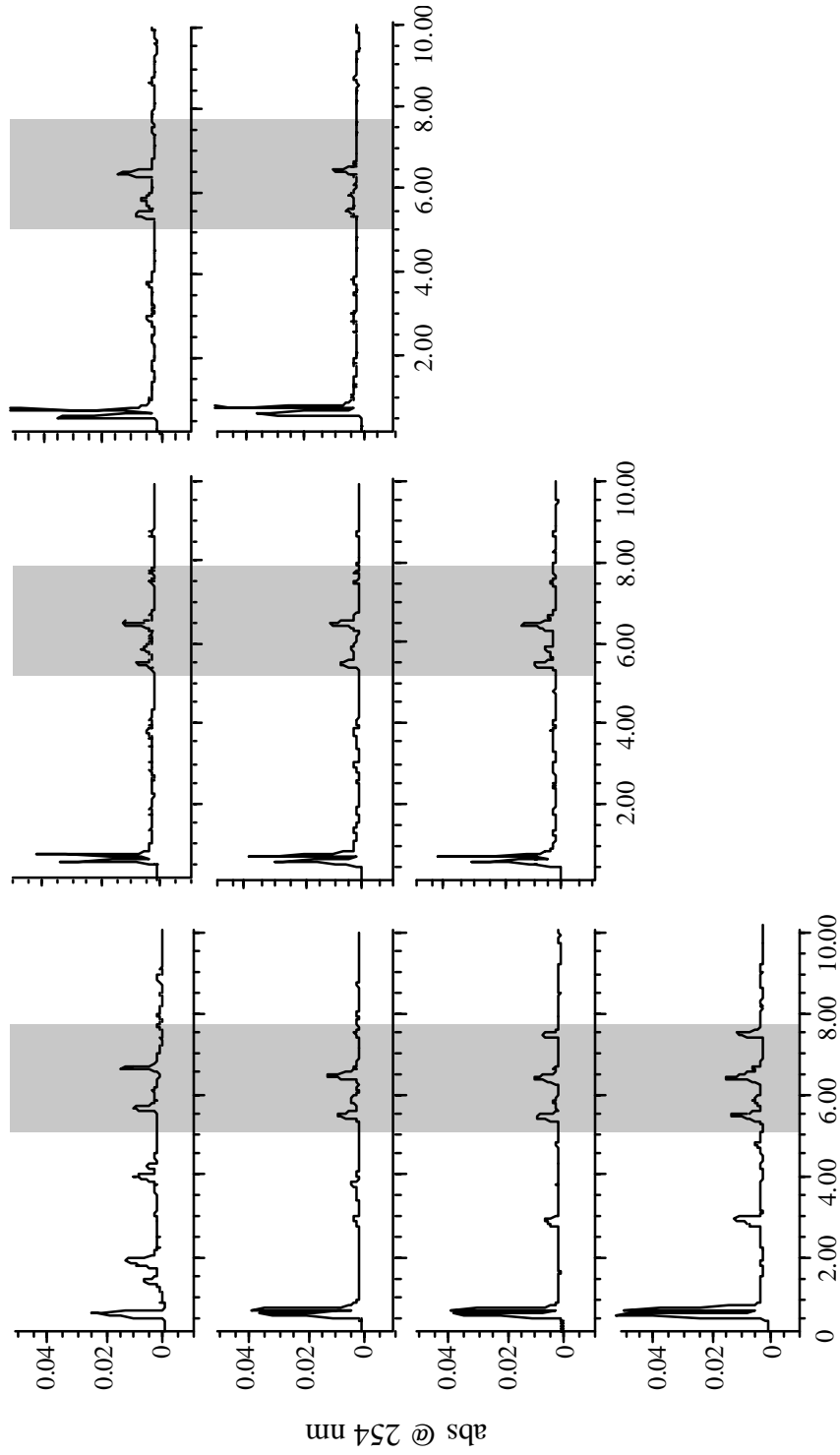
96

Seedling age at time of initial UV-B exposure:

4 d

5 d

6 d



retention time (min)

## E. CHI Activity Assay

A possible consequence of anti-CHI scFv expression in plants is the alteration of levels of flavonoid end-products due to direct binding of the scFv to the CHI enzyme. Binding of the scFv could impair CHI function in a number of ways including inhibiting the catalytic activity of CHI, altering its subcellular localization, affecting its stability, or interfering with its ability to interact with other flavonoid enzymes. The transgenic line, B7b-1, which was shown to have reduced levels of flavonol glycosides, was subjected to enzyme assays to determine if the reduction in flavonoid accumulation was due to an alteration of the kinetic properties of CHI. Specifically, the  $K_M$  and the  $V_{max}$  of CHI from a B7b-1 lysate were compared with those of CHI from wild-type lysates using an *in vitro* activity assay. Briefly, the assay involves mixing dilutions of plant lysates with known amounts of the substrate, naringenin chalcone. The conversion of the substrate is then measured over time by monitoring the decrease in absorbance at 370 nm, the absorption maximum for the substrate. Naringenin chalcone, however, is not commercially available due to its relative instability. It rapidly cyclizes to form naringenin at neutral pH (Mol et al. 1985). Thus, prior to performing CHI activity assays, a fresh substrate was synthesized by base hydrolysis of naringenin, followed by acidification to recover naringenin-chalcone crystals (Moustafa and Wong 1967).

## Materials and Methods

### *Synthesis of Naringenin Chalcone*

The naringenin chalcone substrate was prepared based on the protocol of Moustafa and Wong (1967). Approximately 250 mg of naringenin (Sigma Chemicals) was boiled in 20 ml of 50% KOH for 5 min. The resulting yellow-orange solution was cooled to 50°C and then placed on ice. While on ice, the solution was acidified to pH 2 by the dropwise addition of concentrated HCl. Lemon-yellow crystals (naringenin chalcone) precipitated out of solution. More crystals formed when the solution was incubated on ice for an additional 10 min. The solution was then extracted twice with 1 volume of ethyl acetate, setting aside the yellow organic phase containing naringenin chalcone after each extraction. The organic phases were combined and mixed with 1 volume of saturated NaCl solution (>5M) to extract trace aqueous materials suspended in the organic phase. The organic fraction was transferred to a new flask and approximately 30 g anhydrous Na<sub>2</sub>SO<sub>4</sub> crystals were added to further extract aqueous materials. The clarified, yellow organic phase was transferred into an evaporator flask, which was attached to a rotavap apparatus (Buchi) and the liquid was evaporated at room temperature. The resulting crystals were transferred to a glass vial, sealed in aluminum foil, and stored at 4°C.

### *Preparation of Plant Lysates*

Seeds were surface-sterilized, vernalized, and grown in continuous white light as described in appendix B, except that no antibiotics were used. The seedlings were

harvested after 5 d of growth. Approximately 250 mg of seedlings was ground in liquid N<sub>2</sub> in a pre-chilled mortar. Immediately upon thawing, the powderized plant material was further macerated in 500 µl cold assay buffer [4.2% (v/v) 0.1 M K<sub>2</sub>HPO<sub>4</sub>, 95.8% (v/v) 0.1 M KH<sub>2</sub>PO<sub>4</sub>, pH 5.5] containing an EDTA-free mixture of proteinase inhibitors (Proteinase Inhibitor Mix, Boehringer Mannheim) at 1 tablet per 10 ml assay buffer, as recommended by the manufacturer. The resulting homogenate was incubated on ice for 1 h. The soluble fraction was separated by centrifugation at 16,000 x g for 15 min at 4°C. Bradford assays were then performed to quantify the total soluble protein in each sample.

### *Enzyme Assays*

Assays were performed in 96-well UV-transparent microtiter plates (flat-bottom, cat#21-377-203, Fisher Scientific). Plates were kept on ice before and during the addition of all reagents. On each plate, a portion of the wells was allotted for controls, while the rest were used for experimental reaction mixtures. Prior to the addition of substrate, 145 µl of 50 µg/ml cold plant lysate in assay buffer were dispensed into each well. At time = 0 min, cold substrate (stock solution: 10 mg/ml in 95% ethanol) diluted in assay buffer was added to each reaction mixture at a concentration of 30, 60, 119, 238, or 477 µM in a final volume of 150 µl. As a control for the spontaneous cyclisation of naringenin chalcone, a series of wells with no lysate, only assay buffer containing the substrate at the abovementioned concentrations, was included. For both control and experimental wells, 150 µl of assay buffer was used as a blank. Enzyme activity was monitored at room temperature by checking the decrease in absorbance at 370 nm every 2 min for up to 30 min using an ELISA plate reader (MRX, Dynatech Laboratories). The

$K_M$  and  $V_{max}$  values were calculated by plotting the inverse of the rate of conversion (change in absorbance per hour) against the inverse of the corresponding substrate concentration in a Lineweaver-Burke plot (Enzyme Kinetics v. 1.5, Trinity Software). In such a plot, the  $K_M$  is the negative of the reciprocal of the X intercept, while the  $V_{max}$  is the reciprocal of the Y intercept.

### Results and Discussion

This study was performed to determine the effect of scFv's on CHI activity in two transgenic lines, including the low-level expressor, B7b-1, which had consistently shown reduced levels of glycosylated flavonols. To accomplish this, the CHI substrate, naringenin chalcone, had to be synthesized because it is not commercially available due, in part, to its relative instability at neutral pH, rapidly cyclising to form naringenin. From 250 mg of naringenin, over 100 mg of naringenin chalcone was recovered even after an extensive extraction procedure. This amount was more than adequate for multiple microtiter plate-based assays. Moreover, the preparation appeared to be stable during the entire 6-week period devoted to activity assay experiments when stored in the dark at 4°C either as powder or as a 10 mg/ml solution in 95% ethanol. The absorbance profile scan (250 nm to 450 nm) of a naringenin chalcone substrate solution (1 µl of 10 mg/ml stock diluted in 750 µl 95% ethanol) performed on the 6<sup>th</sup> week after substrate synthesis did not differ significantly from the profile generated on the day the substrate was synthesized (data not shown).

The optimal pH for CHI activity is between 7.3 and 7.8 in petunia and soybean (Mole et al. 1985; Moustafa and Wong 1967). However, extensive spontaneous

cyclisation had been reported for assays done at this pH range for both plant species (Mol et al. 1985; Moustafa and Wong 1967). In the test assay performed at pH 7, nearly 50% of the conversion of naringenin chalcone to naringenin was found to be non-enzymic, as the rate of decrease in absorbance at 370 nm of mixtures with no lysate was close to half the rate for mixtures containing 50 µg/ml lysate from wild-type *Arabidopsis* seedlings (Fig. 11). This is consistent with observations for assays performed with extracts from petunia flower buds (Mol et al. 1985), in which spontaneous cyclisation in a reaction mixture containing 50 µg/ml of crude lysate accounted for over 30% of total conversion of naringenin chalcone at pH 7.5. Thus, to minimize spontaneous conversion while maintaining more than half-maximal CHI activity, succeeding assays were performed at pH 5.5, patterned after the conditions described by Mol et al. (1985).

Six independent experiments were performed using freshly-extracted plant lysates in each case (Fig. 12). However, only replicates 2, 3, and 6 were included in the calculations for the kinetic properties of CHI (Table 3) because the other replicates did not reach saturation at the highest substrate concentration used (477 µM). The  $K_M$  and  $V_{max}$  values obtained for CHI from wild-type plants and the two transgenic lines varied substantially among experiments. There was no clear trend that unequivocally showed altered enzyme activity in the transgenic plants. The results of calculations for the kinetic properties obtained for CHI do not appear to significantly differ between the plant groups, as standard errors for the mean  $K_M$  and  $V_{max}$  values for the three groups overlap. Therefore, at least *in vitro*, the scFv's do not appear to affect CHI activity in transgenic plants. One possibility is that the scFv is not binding the catalytic site, but a structural site, consistent with the idea that the flavonol reduction observed *in planta* may be due to

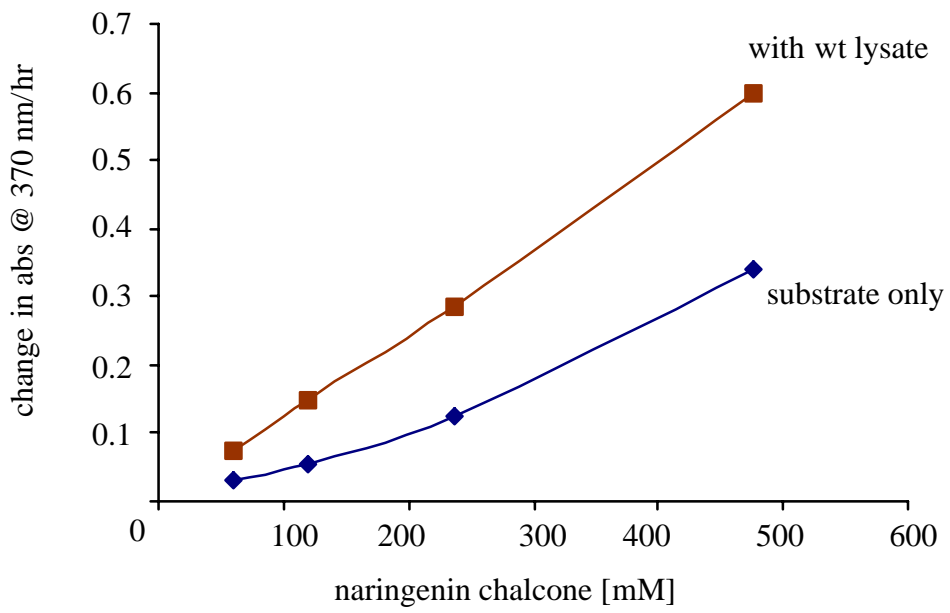
an scFv-mediated disruption of flavonoid enzyme organization. It is also possible, however, that the assay conditions did not allow a strong scFv-CHI interaction to be maintained compared to physiological conditions. Specifically, the pH used in the assay may be outside the range for efficient scFv binding of target antigen. Therefore, although the results of the assay are consistent with the idea that the scFv is binding a structural site on CHI that has no effect on *in vitro* catalytic activity, the possibility that scFv binds the catalytic domain is not completely ruled out as the primary cause of the observed down-regulation of flavonoid biosynthesis in B7b-1.



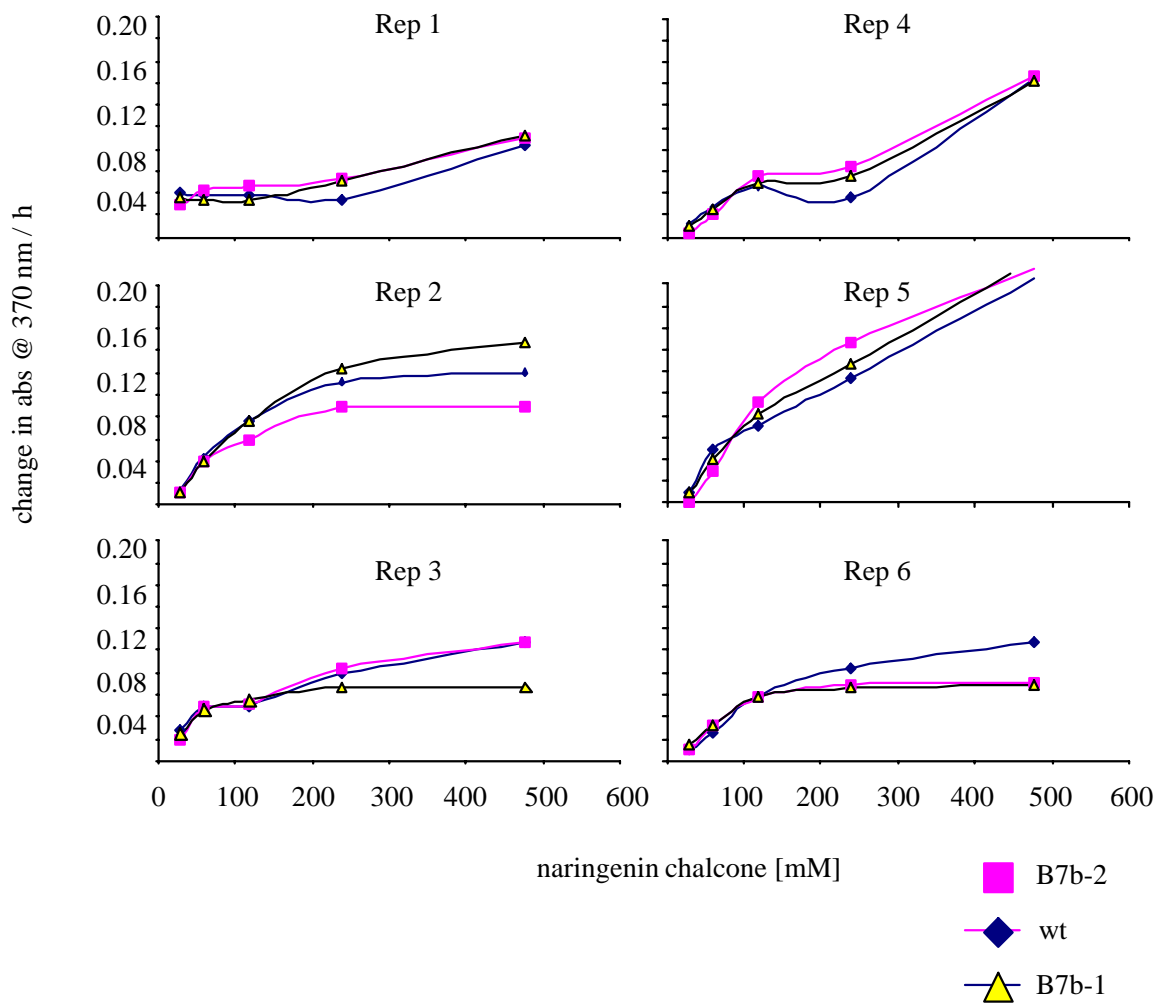
## References

- Mol, J. N. M., M. P. Robbins, R. A. Dixon and E. Veltkamp (1985). "Spontaneous and enzymic rearrangement of naringenin chalcone to flavanones." Phytochem **24**: 2267-2269.
- Moustafa, E. and E. Wong (1967). "Purification and properties of chalcone-flavanone isomerase from soya bean seed." Phytochem **6**: 625-632.

**Figure 11.** Conversion of naringenin chalcone (substrate) to naringenin at pH 7 in the presence or absence of 50 µg/ml wild-type (wt) crude lysate.



**Figure 12.** Comparison of CHI activities in lysates from wild-type (wt) and transgenic 5-d-old seedlings. B7b-1: low-level scFv-expressor with reduced glycosylated flavonols; B7b-2: expresses the same scFv gene at approximately 20-fold higher levels than B7b-1, but does not show effects on flavonoid synthesis.



**Table 3.**  $K_M$  and  $V_{max}$  values obtained from double-reciprocal plots of kinetic data for each plant group.

Replicate	$K_M$			$V_{max}$		
	wt	B7b-1 <sup>a</sup>	B7b-2 <sup>b</sup>	wt	B7b-1	B7b-2
2	180	287	92	0.230	0.313	0.138
3	232	132	248	0.258	0.172	0.266
6	166	146	146	0.179	0.148	0.165
average	192	188	162	0.222	0.211	0.190
s.e.	47	83	111	0.032	0.078	0.095

<sup>a</sup>B7b-1: low-level expressor with reduced flavonol glycosides.

<sup>b</sup>B7b-2: expresses the same scFv gene approximately 20 times higher than B7b-1, but does not show phenotypic effects on flavonoid synthesis.

*Curriculum vitae*

## Michael Carmelo Orda Santos

Born in Manila, Philippines on April 16, 1970

University address: 2119 Derring Hall, Dept. of Biology  
Virginia Polytechnic Institute and State University  
Blacksburg, VA 24061 USA  
Tel: (540) 231-9375  
Email: [mike.santos@vt.edu](mailto:mike.santos@vt.edu)

Philippine address: 493 A. Mabini St.,  
Manggahan, Pasig City 1600  
Philippines  
Tel: (011-632) 646-2386  
Email: [msantos@I-manila.com.ph](mailto:msantos@I-manila.com.ph)

### Education

Ph D, Biology, expected to graduate on *May 2001*, Virginia Polytechnic Institute and State University  
Blacksburg, VA 24061

MS, Crop Sciences, *June 1996*, University of Georgia, Athens, GA 30602

BA, Biology, *June 1993*, Bennington College, Bennington, VT 05201

Attended the University of the Philippines, *June 1988 - March 1989*, Diliman, Quezon City, Philippines

### Research Experience

University of Georgia, Department of Crop and Soil Sciences, Athens, GA. Under the advisorship of Dr. Wayne Parrott, worked on *Agrobacterium*-mediated transformation of *Arabidopsis* with two novel genes for insect resistance, a synthetic *Bacillus thuringiensis* gene and the cowpea trypsin inhibitor gene. Transgenic *Arabidopsis* plants were later used in feeding assays to assess the effect of combining the resistance genes against important soybean crop pests. (*Spring '93-Spring '96*)

Bennington College, Sciences Division, Bennington, VT. Under the advisorship of Drs. Kerry Woods and Michael Mishkind, I investigated the level of diversity within and among three populations of sugar maples (*Acer saccharum*) around Bennington county using random amplified polymorphic DNA (RAPD) technique to differentiate collected samples by DNA profile. (*Fall '91-Fall '92*)

University of North Carolina, Department of Botany, Chapel Hill, NC. As a recipient of a National Science Foundation grant for summer undergraduate research, I worked in the laboratory of Dr. Alan Jones. Under Drs. Jones and Michael Edgerton's preceptorship, I worked on the co-expression of *GroES/L* chaperonins with oat phytochrome in *E. coli* to see if aggregation of phytochrome subunits can be suppressed by this strategy. (*Summer '92*)

Cornell University, Department of Plant Breeding and Biometry, Ithaca, NY. I worked in the laboratory of Dr. Elizabeth Earle. Under the guidance of Dr. Timothy Metz, I worked on the propagation, transformation with an insect resistance gene (*Bt*), and regeneration of *Brassica oleracea* from tissue culture. (*Winter '92*)

Cornell University, Section for Ecology and Systematics, Ithaca, NY. I worked in the laboratory of Dr. Charles Mohler who was then studying the survival of vetch seeds in soil that had experienced different farming treatments. I was involved with the verification of mathematical models for the effects of various soil treatments on vetch seedling emergence. (*Winter '92*)



The International Rice Research Institute, Department of Plant Breeding, Los Baños, Philippines. Under the guidance of Mr. Rodolfo Aquino in the department headed by Dr. Gurdev Khush, I gained first-hand knowledge on the Institute's selection techniques in screening for resistance against rice insect pests (e.g. brown planthopper and green leafhopper), selection techniques in screening for different starch/amylose content among different rice cultivars, and maintenance of the rice germplasm. (*Winter'91*)

Bennington College, Sciences Division, Bennington, VT. I worked as an undergraduate research assistant in the organic chemistry laboratory of Dr. Ranil Guneratne. I was involved in a project that aimed at synthesizing fluorinated heterocyclic compounds. (*Summer'91*)

## Teaching and Research Supervision Experience

Virginia Polytechnic Institute and State University, Department of Biology. I was directly responsible for the training and supervision of three undergraduate students in the laboratory of Dr. Winkel-Shirley. I trained Ben Crowley (spring and summer'99), Bryony Hasychak (winter'98 to winter'99), and Karen Vaillant (fall'99 and spring'00) key molecular techniques to enhance their level of participation in different aspects of my research project.

Virginia Polytechnic Institute and State University, Department of Biology. I taught three *general biology laboratory classes* during fall'96 and spring'97. In fall'97 and spring'98, I taught two *principles of biology lab classes for majors*. For fall'98 and spring'00, I taught one *molecular biology lab class*.

### Ratings in a 1 to 4 scale:

---

Fall '96: 3.3, 3.6, 3.9  
Spr '97: 3.1, 3.4, 3.6  
Fall '97: 3.7, 3.9  
Spr '98: 3.4, 3.6  
Fall '98: 3.5  
Spr '00: 3.7

Bennington College, Sciences Division, Bennington, VT. I worked as an undergraduate teaching assistant in chemistry. Primary duties included tutoring and setting up the lab prior to class experiments of Drs. Ranil Guneratne and Reuben Puentedura. (*Fall'91-Fall'92*)

## Publications

Santos MO, All J, Adang M, Boerma R, Parrott W. (1997) Testing transgenes for insect resistance using *Arabidopsis*. *Molecular Breeding*. 3:183-194.

Edgerton MD, Santos MO, Jones AM. (1993) *In vivo* suppression of phytochrome aggregation by the GroE chaperonins in *Escherichia coli*. *Plant Molec Bio*.21:1191-1194.

Santos MO, Winkel-Shirley B. Immunomodulation of flavonoid biosynthesis in transgenic *Arabidopsis*. (*manuscript to be submitted*)

## Presentations

Doctoral defense, Virginia Polytechnic Institute and State University on April 10, 2001. Seminar title: Modulating flavonoid biosynthesis using phage-derived antibodies.

Gordon Research Conference on Macromolecular Interactions, Queen's College Oxford, England on August 6-11, 2000. Abstract title: Modulating flavonoid biosynthesis in transgenic *Arabidopsis*.

6th International Congress of Plant Molecular Biology, Quebec, Canada on June 18-24, 2000. Abstract title: Modulating flavonoid biosynthesis in transgenic *Arabidopsis*.

Virginia Academy of Science, Radford University, Radford, VA on May 25, 2000. Oral presentation and abstract title: Modulating flavonoid biosynthesis in transgenic *Arabidopsis*.

Plant Molecular Biology Discussion Group, Virginia Polytechnic Institute and State University on January 26, 2000. Oral presentation title: Immunomodulation of flavonoid biosynthesis in transgenic *Arabidopsis*.

International Rice Research Institute, Los Baños, Philippines on July 13, 1999. Oral presentation title: Expression of phage-derived antibody genes to modulate flavonoid biosynthesis in transgenic *Arabidopsis*.

10th International Congress on *Arabidopsis* Research, Melbourne, Australia on July 4-8, 1999. Plenary session oral presentation and abstract title: Expression of phage-derived antibody genes to modulate flavonoid biosynthesis in transgenic *Arabidopsis*.

Plant Physiology Seminar Series, Virginia Polytechnic Institute and State University on April 15, 1999. Oral presentation title: *In planta* modulation of flavonoid metabolism.

Gordon Research Conference on Macromolecular Interactions, Queen's College Oxford, England on September 13-18, 1998. Abstract title: Isolation of phage-derived antibodies for immunomodulation of flavonoid metabolism.

9th International Meeting on *Arabidopsis* Research, Madison, WI on June 24-28, 1998. Abstract title: Isolation of phage-derived antibodies for immunomodulation of flavonoid metabolism.

Virginia Academy of Science, George Mason University, VA on May 28, 1998. Oral presentation and abstract title: The use of phage display technology in developing antibodies against plant proteins.

Biology Departmental Seminar, Virginia Polytechnic Institute and State University on April 10, 1998. Oral presentation title: Antibody production against chalcone synthase using the phage display technique.

American Society of Plant Physiologists - Southern Section, Roanoke, VA on March 22, 1998. Oral presentation title: Protein-protein interaction among enzymes of the flavonoid metabolic pathway (Production of antibodies using phage display technology).

American Society of Microbiologists - Virginia Branch, University of Richmond, Richmond, VA on January 17, 1998. Oral presentation title: Antibody production against plant proteins using the phage display technique.

8th International Meeting on *Arabidopsis* Research, Madison, WI on June 25-29, 1997. Abstract title: Production of antibodies against chalcone synthase and chalcone isomerase using the phage display technique

Virginia Academy of Science, Blacksburg, VA on May 23, 1997. Oral presentation and abstract title: The use of phage display technology in developing antibodies against plant proteins.

Plant Molecular Biology Discussion Group, Virginia Polytechnic Institute and State University on October 29, 1996. Oral presentation title: *Arabidopsis* as a model system to test the efficacy of transgenes for insect resistance.

World Congress on *In Vitro* Biology, San Francisco, CA on June 24, 1996. Oral presentation and abstract title: *Arabidopsis* as a model system to test the effectiveness of transgenes for insect resistance.

Summer Undergraduate Research Experience (SURE), University of North Carolina, Chapel Hill, NC on August 5, 1992. Oral presentation title: *In vivo* suppression of phytochrome aggregation by the GroE chaperonins in *Escherichia coli*.

## **Other Seminars Attended**

International Symposium on the Green Fluorescent Protein, Rutgers University, New Brunswick, NJ on October 18-22, 1997.

Workshop on Transgenic Plants: Biology and Applications, Tuskegee University, Tuskegee, AL on April 20-22, 1996.

## **Awards and Grants Applied for**

John Johnson Memorial Scholarship Award for outstanding senior graduate student in molecular biology; awarded by the Fralin Biotechnology Center of Virginia Polytechnic Institute and State University on April 28, 2000.

National Science Foundation and the North American Arabidopsis Steering Committee. Travel grant for the 10<sup>th</sup> International Congress on *Arabidopsis* Research in Melbourne, Australia. (funded: \$1262.50 Summer '99)

Graduate Research Development Project (GRDP), Graduate Student Assembly, Virginia Polytechnic Institute and State University. Abstract title: Expression of phage-derived antibody genes to modulate flavonoid biosynthesis in transgenic *Arabidopsis*. (funded: \$250 Summer '99)

Virginia Academy of Science, Small Grants Division, Richmond, Virginia. Abstract title: Immunomodulation of flavonoid biosynthesis. (funded: \$925 Spring '99)

Sigma XI, Grants In-Aid of Research, Research Triangle Park, NC. Abstract title: *In planta* modulation of flavonoid biosynthesis: evidence for the flavonoid metabolon. (funded: \$500 Spring '99)

Graduate Student Assembly Travel Fund Program, Virginia Polytechnic Institute and State University. Abstract title: Isolation of antibodies for immunomodulation of flavonoid metabolism. (Spring '98)

Graduate Research Development Project (GRDP), Graduate Student Assembly, Virginia Polytechnic Institute and State University. Abstract title: Antibody production using phage display technology. (funded: \$500 Spring '97)

Sigma XI, Grants In-Aid of Research, Research Triangle Park, NC. Abstract title: Production of antibodies against flavonoid enzymes Using phage display technology. (funded: \$500 Spring '97)

Department of Biology, Virginia Polytechnic Institute and State University. Matching grants for awards and funded proposals: \$2750 (Spring'97 - Spring'00)