

# Chapter 3

## The proposed Work

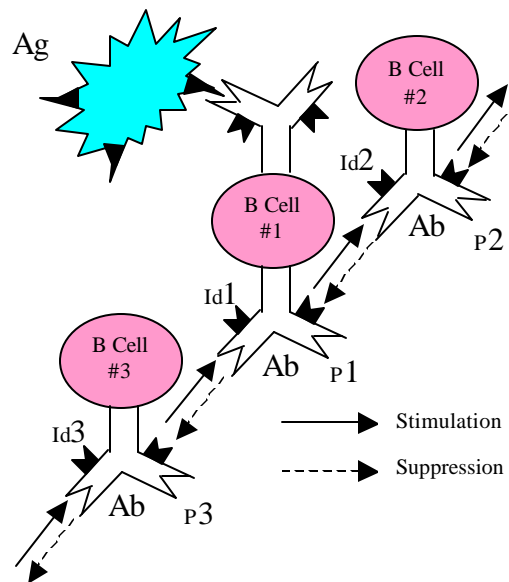
**A**utonomous robots are expected to interact with their dynamic/changing environment. This interaction requires certain level of behavior-based intelligence, which facilitates the dynamic adaptation of the robot behavior accordingly with his surrounding environment. Much research has been done in biological information processing systems to model the behavior of an autonomous robot. The Artificial Immune System (AIS) is one such system that provides a new paradigm suitable for dynamic problems dealing with an unknown environment, rather than static problem. The immune system has some features such as memory, tolerance, diversity and more that are appropriate in this context.

A research done by N. K. Jerne and others reveal that the immune system has networks that use stimulation and suppression among its elements to achieve a certain behavior [35]. Many researchers to benefit from features of the immune system have addressed this powerful adaptation property. We have shown an application in previous work on autonomous mobile robots using an artificial immune network by applying it to a pursuit evasion problem. Subsequent work was on how to incorporate meta dynamics function into the robot behavior. The immune system has an important feature called meta-dynamics in which new species of antibodies are produced continuously from the bone marrow. If the robot cannot deal with the current situation, new behavior (antibodies) will be generated by the meta dynamics function. This behavior should be incorporated into the existing immune system to gain immunity against new environmental changes. We decided to use Artificial Neural Networks (ANNs) to overcome this problem, to be achieved in two stages. First, during the Artificial Immune Network (AIN) learning process, a neural network will record the learnt situations, and memory cells will be built.

Second, in case of new behavior of which there is no memory, a selection mechanism will decide whether to create new antibodies (new AIN learning process) and build the corresponding memory for it, or use an approximated behavior of the already existed ones. The overall system should increase the productivity of the simulated immune system and approach the real interaction between the immune system and its memory. This novel technique can be applied to many robotics applications, where autonomous robots are required to learn and adapt their behaviors in response to their environmental changes.

### 1. Immune Networks

It has been found that B Cells antibodies do not recognize all the epitops on the Ag body. This may attract the attention of different B cells to interact with this Ag. The relationship between the Ag, and its corresponding Ab is as the key to the lock. The portion of the Ag that can be recognized by the Ab is called epitop (Ag determinant), and the corresponding part of the Ab that determines it is called paratop. Surprisingly, we find that each Ab has antigenic characteristics by having by having Ag determinant called idiotop. This means that one part of an Ab can be regarded by another Ab as an Ag.

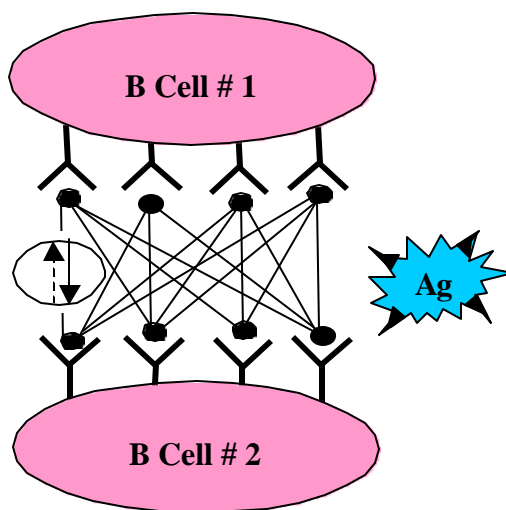


**Figure3.1** Jerne's Idiotoxic Network

N. K. Jerne proposed a hypothesis called Idiotypic Network Hypothesis. The basic idea of this hypothesis is that the immune system is constructed of a Lymphocyte network. These Lymphocytes communicate among each other mutually to achieve the main goal of the immune system. The idiotope Id1 of Ab1 will stimulate the paratope P2 of B cell 2, which has Ab2 attached to it. On the other hand, from B cell #2 point of view, we find that Id1 acts as an Ag. Consequently, Ab1 with B cell #1 will be suppressed by Ab2, see Figure3.1. From another perspective we will find that Ab3 stimulate Ab1 through Id3. The whole network members will mutually stimulate and suppress each other with a closed loop chain that acts as a self non-self recognizer. There are many applications that recruit the Immune networks to achieve a certain goal. While doing so, they get benefit from the immune system's features like self non-self discrimination, specificity, and memory.

## 2. Artificial Immune Network

We designed an immune network based upon the previous discussion of Jerne's approach. T cells to stimulate B cells and their antibodies to interact mutually in order to overcome the antigen behavior. The structure of the artificial immune network is basically two B cells; each cell has four antibodies attached to it. Each antibody is fully connected to all the other B-cell antibodies to allow stimulation and suppression, see Figure3.2. There is also stimulation and suppression among B cells Ab's and the Ag.



**Figure3.2** The Artificial Immune Network

The simulation starts with initial concentrations for all Ab's inside B cells. As stimulation and suppression take place, all Ab's change their behavior concentrations till the Ag behavior is dropped to the desired concentration. At this point, the Ag behavior is totally suppressed, and a second stage takes place by building memory cells for future processing. Our simulation consists of two autonomous robots, each of which represents a certain B cell. These robots are trying to overcome the behavior of another robot (Ag), by stimulating and suppressing each other's behaviors (Ab's).

We developed equations for the concentrations of antibodies in each B cell; also a progress factor was introduced to measure the validity and success of each antibody. Antibodies will be used when exceeding a certain threshold based of their concentrations.

$$a_i = S_i \sum_i^N C_i \quad (3.1)$$

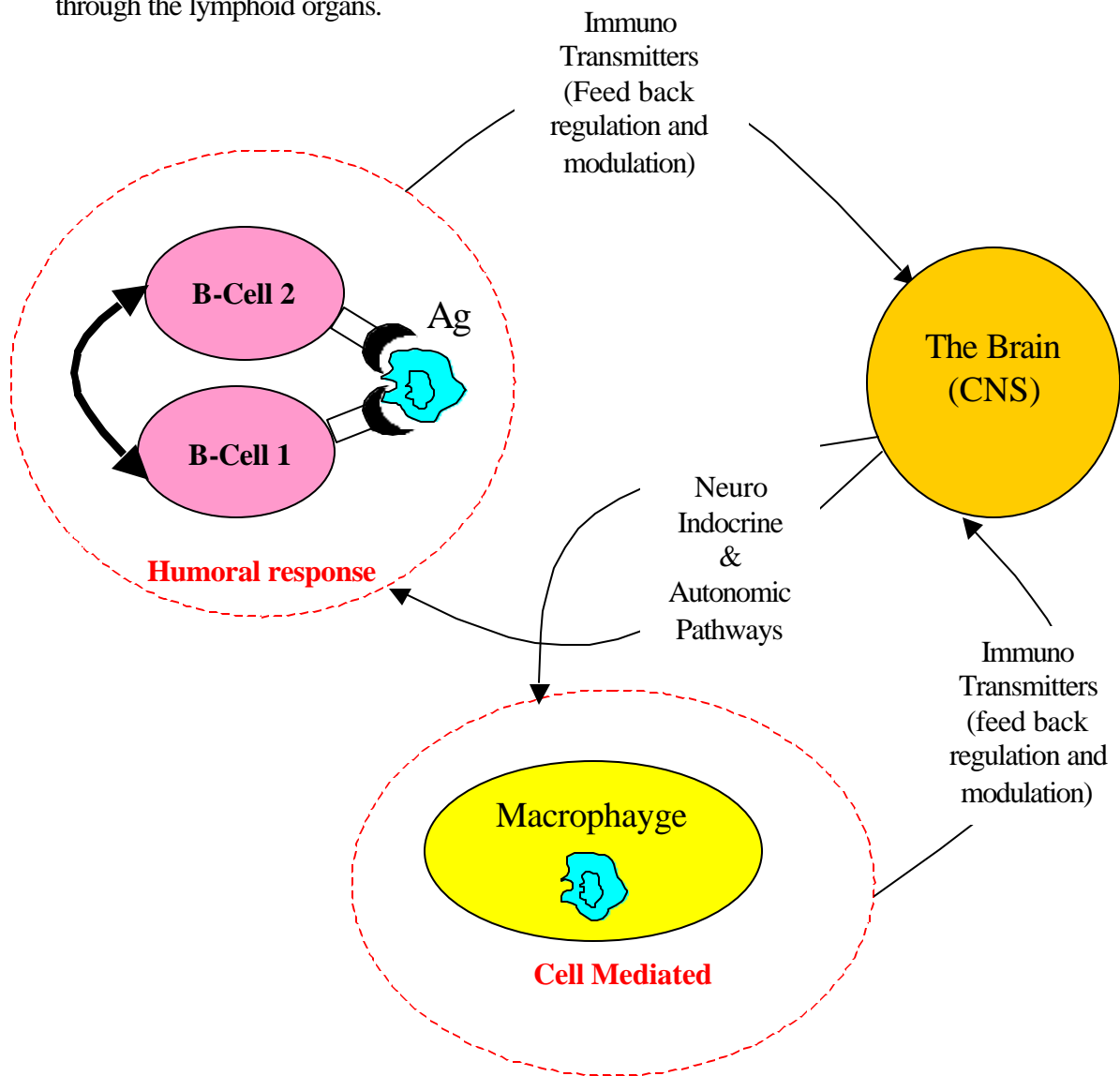
$$P_i = (1 - S_i) \sum_j^M C_j \quad (3.2)$$

$$C_{ik} = \sum_i^N a_i - \sum_j^M P_j + g_i \quad (3.3)$$

Where  $i = 1..N$ , and  $N$  represents the number of antibodies in BCell#1.  $j = 1..M$  and  $M$  correspond to the number of antibodies in each B-cell#2.  $S_i$  represents the success ratio for each antibody  $i$ , and it can be calculated as the ratio of the count of correct responses (actions) divided by the total number of responses taken by this antibody.  $C_i$  represents the current concentration of antibody  $i$  in the B cell, and it should exceed the concentration threshold for the antibody to respond to antigen stimulation. The first term of the right hand side of Equation (3.3) represents the stimulation activation level spread by other antibodies in the herding immune network, and it can be calculated using Equation (3.1). The second term represents the suppression activation level spread by other antibodies in the same immune network, and it can be calculated using Equation (3.2). The third term represents the stimulation that an antibody receives from an antigen and it controls the balance of the immune herding network.

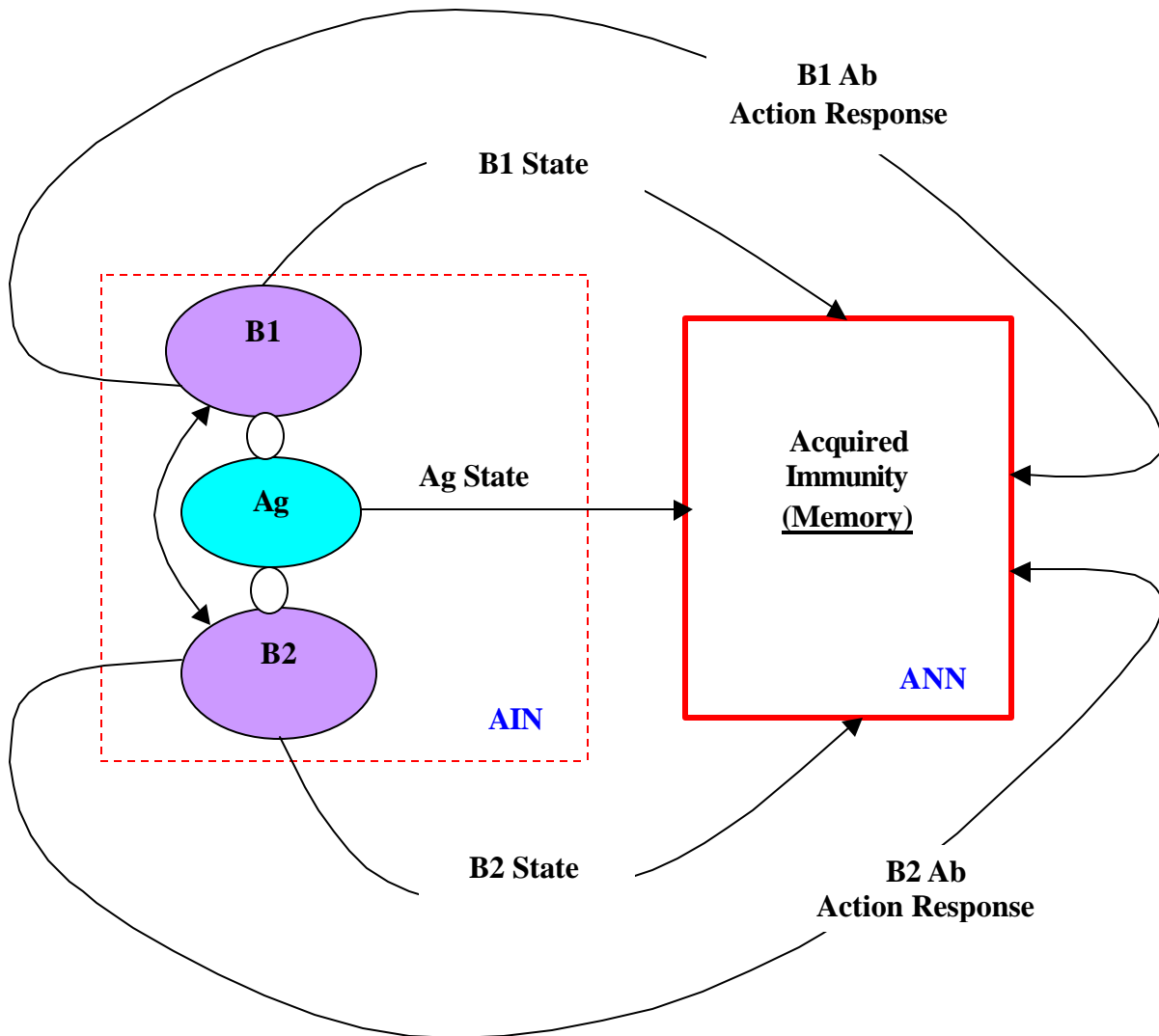
### 3. Neuro Immune Interaction

The brain may directly influence the immune system by sending messages down nerve cells. Networks of nerve fibers have been found that connect to the thymus gland, spleen, lymph nodes, and bone marrow. Moreover, experiments show that immune function can be altered by actions that destroy specific brain areas. The image that is emerging is of closely interlocked systems facilitating a two-way flow of information, primarily through the language of hormones. Immune cells, it has been suggested, may function in a sensory capacity, detecting the arrival of foreign invaders and relaying chemical signals to alert the brain. The brain, for its part, may send signals that guide the traffic of cells through the lymphoid organs.



**Figure3.3** Biological Neuro Immune Interaction

We simplified the biological neuro-immune interaction focusing only on the basic main arms of the immune system, which are the humoral response, and the cell mediated response, see Figure3.3. We will focus on the humoral response in our research. The network structure used in humoral response is the same artificial immune network illustrated in Figure3.3.



**Figure3.4** Building Memory

Figure 3.4 illustrates the basic mechanism for building our Artificial Immune Memory (AIM), which is the acquired memory after Ag processing. We used a feed forward Artificial Neural Network (ANN) architecture to model the acquired memory. During the training mode of the ANN, the network is fed with the state of Ab's, state of antigen, and the required response to overcome the Ag. So, the ANN is learning how the Ag suppression process takes place.

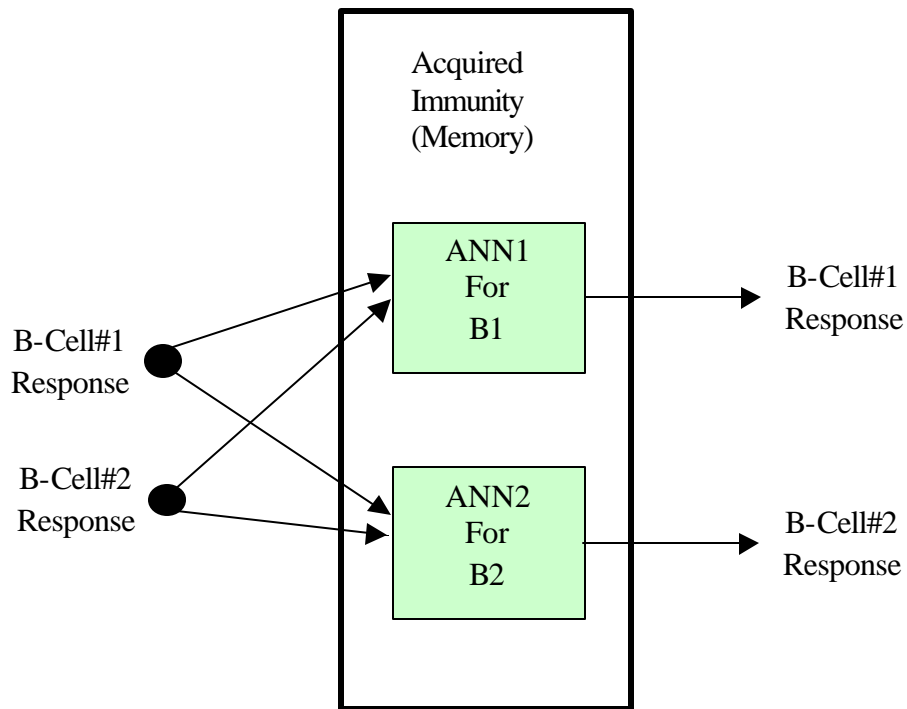
When the host encounters a new Ag, it consults the pre-trained AIM first, and that is exactly what happens in the real biological immune system. In this case, the AIM network is in the test mode, and basically no training process is involved. The input in the test phase should be the Ab's status, and Ag status. The output should be the desired response that will overcome the behavior of the encountered Ag.

#### **4. The AIM Structure**

When the host encounters a new Ag, it consults the memory cell first, Figure3.5 illustrates the internal structure AIM network. The structure shown is in the test mode, since we assume that the network has already learned, and ready for test. In our initial design we chose the B cell state to be the position of the robot itself. Using the same concept, the state of the Ag was chosen to be its current location. The output from the pre- trained AIM network will be the current concentration for B cell #1, and B cell #2.

#### **5. Meta Dynamics and the Neuro-Immune Network**

The immune system has an important feature called meta-dynamics in which new species of antibodies are produced continuously from the bone marrow. If the robot (B-Cell) cannot deal with the current situation, new behaviors (antibodies) should be generated by the meta dynamics function. This behavior should be incorporated into the existing immune system to gain immunity against new environment changes. We decided to use a feed forward Artificial Neural Network (ANN) to overcome this problem. After the artificial immune network learns how to suppress the Ag behavior.



**Figure3.5** Acquired Immunity Network

When a new Ag is trying to attack the host, the AIM will be consulted first to access previous encountered cases. If its performance is unsatisfactory, the network is unable to completely suppress the Ag behavior, then this Ag is “new” for the immune system and the immune network has to detect how to defeat it. This new knowledge will be fed to the AIM, and update its experience for future processing.

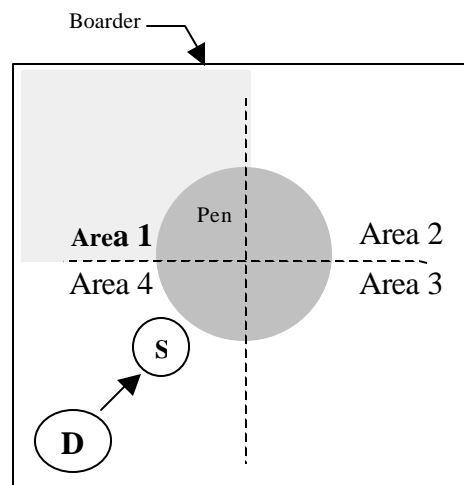
The overall system should increase the productivity of the simulated immune system and approach the real relationship between the immune system, and the central nervous system. This novel technique can be applied to many robotics applications in industry, where autonomous robots are required to have adaptive behavior in response to their environment.



## 6. Case Study: Artificial Immune Systems: Application to Autonomous Agents\*

### I. The Dog and Sheep Problem

In this section, we describe the application of AIS the “dog and sheep” problem. Generally, this problem is a simple herding task in which a dog (D) is trying to guide a sheep (S) to a specified area (Pen) without exceeding the borders of the problem, see Figure1. The number of dogs and sheep in this problem may vary according to the problem structure. From DARS point of view, both the dog and the sheep are simulated in the real world by mobile autonomous robots as agents. On the other hand, immunologically, these robots will be considered as B cells.



**Figure3.6** The Dog and Sheep Problem

Normally, simulation takes place first, as we believe that many robotic tasks are too expensive or dangerous to learn from actual experience in the real environment. We designed a simple simulation example that uses two dogs and one sheep. The first designed program tried to simulate the herding process without using the immune system features. The two dogs were herding the sheep into the pen autonomously without communication.

\* This work was a paper published in the IEEE SMC2000 International Conference on Systems, Man, and Cybernetics, Nashville, Tennessee, 2000.

Table 1 summarizes inputs and outputs for autonomous agents, which are two dogs and one sheep. The basic idea is that each agent has to perceive his environment first through sensation, and then chooses the suitable response among all available responses to achieve the overall goal. The goal of the two dogs is to herd the sheep into the pen, while the goal of the sheep is to avoid them.

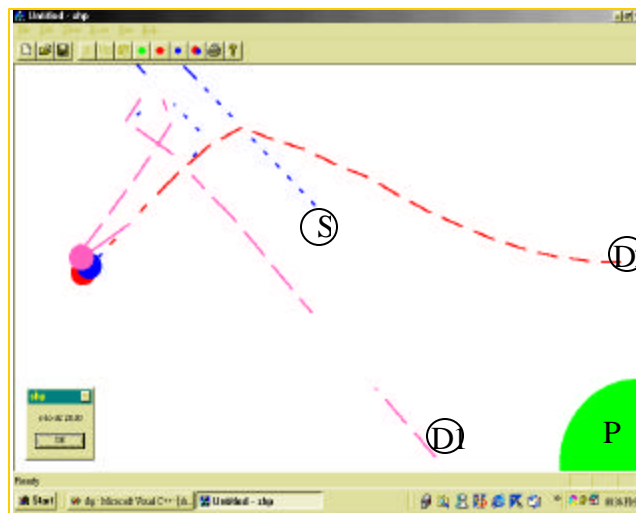
	<b>Input</b>	<b>Output</b>
<b>Dog</b>	Distance between the sheep and the pen. Distance between the sheep and the dog. Distance between the dog and the pen. Positions of all agents: the two dogs, and the sheep.	New direction for movement for the two dogs according to their behavior.
<b>Sheep</b>	Distance between the first dog and the sheep. Distance between the second dog and the sheep. Positions of all agents: the two dogs, and the sheep.	New direction for movement for the sheep according to its behavior.

**Table3.1** Inputs Outputs for Each Agent

## II. Simulation without Immune Networks

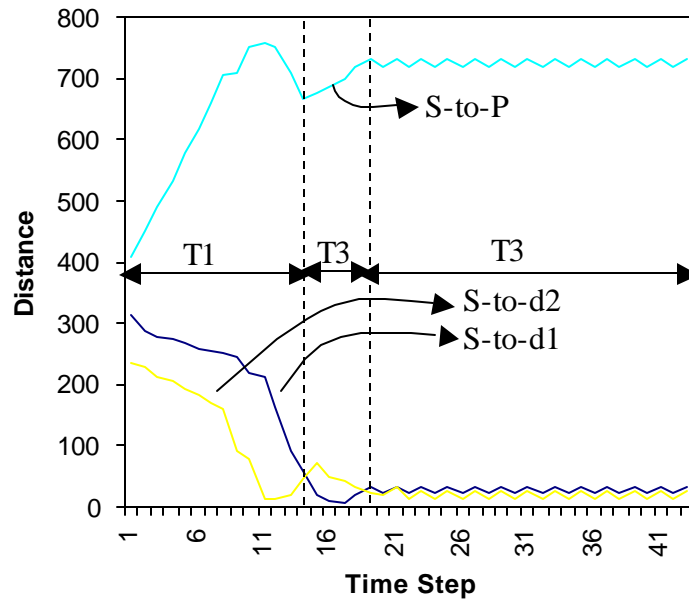
Each of the agents has a set of rules that governs its behavior, and the input output mapping is illustrated in Table.1. For the sake of simplicity, the program was designed to cover the herding process of Area 1 of Figure1. The simulation episode consists of several cycles (time steps), in which each of the two dogs and the sheep has a chance to move once. During the design we made the behavior of dog1, and dog2 different to show the need for communication between them. The behavior of dog1 is characterized by chasing in straight lines responding to sheep movements. On the other hand the behavior of dog2 is characterized by chasing in straight lines, and at certain positions it chase in arcs trying to surround the sheep. Figure2 illustrates a run simulation for the dog and sheep program.

As depicted, the circles labeled D1, D2, and S represents the initial position for the simulation episode. The filled circles represent the final positions after achieving the goal of the herding task. The dotted lines along with the continuous arrows the tracking for the three autonomous agents. In this special run we emphasis on the need for communication between the two dogs by giving a contradictory example. In this example, the two dogs are trying to drive the sheep into the pen autonomously, and without any attention to the each other's behavior.



**Figure3.7** Episode Run Simulation

Figure3 gives better understanding to the scenario of the episode shown in Figure2. The sheep's behavior is designed such that it escapes from the nearest dog. During the time period T1, the distance S-to-d2 between dog2 (D2) and the sheep (S) was smaller than S-to-D1 which mean that D2 was nearer. One can tell from the figure that D2's behavior did well in reducing the sheep to pen distance (S-to-P). As period T1 ends, D1 became merely as close as D2 from S. At this point of time, there an expectation that both dogs will perform better than anyone of them acting individually driving the sheep to the pen. Unfortunately, D1 forces S to move in a direction away from the pen and waste the efforts done by D2 for a certain period of time T2. During T3, the sheep motion oscillates in response to D1, and D2 movements, and no further progress is made. If both dogs have a way of communication among each other, and their progress is announced they should perform better in their future runs.

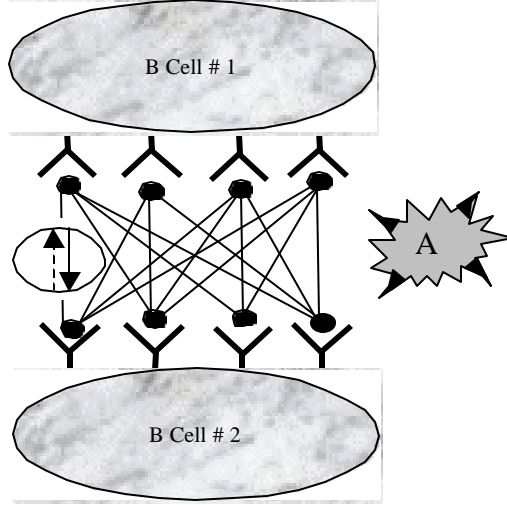


**Figure3.8** Episode Analysis

### III. The Simulated Immune Network

We designed an immune network based upon the previous discussion of Jerne's approach. There are many correspondences between the immune network structure and the autonomous agent's structure. Both dogs (D1 and D2) are considered to be a B cell, and the behavior of each one is considered to be the antibodies. The sheep is considered to be an antigen, and its behavior is the antigen response. The control parameter S-to-P was used as a T cell to stimulate B cells and their antibodies to interact mutually in order to overcome the antigen behavior. The structure of the herding immune network is basically two cells; each cell has four antibodies attached to it. Each antibody is fully connected to all the other B-cell antibodies to allow stimulation and suppression, see Figure4.

We developed equations for the concentrations of antibodies in each B cell; also a progress factor was introduced to measure the validity and success of each antibody. Antibodies will be used when exceeding a certain threshold based of their concentrations.



**Figure3.9** The Immune Herding Network

$$a_i = S_i \sum_j^M C_j \quad (1)$$

$$P_i = (1 - S_i) \sum_{j=1}^M C_j \quad (2)$$

$$C_i = \sum_j^M a_j - \sum_j^M P_j \quad (3)$$

$$C_i = (2S_i - 1) \sum_{j=1}^M C_j \quad (4)$$

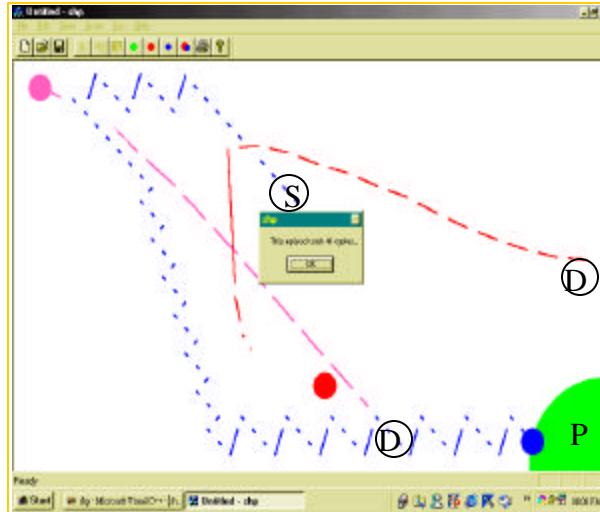
Where  $i = 1..N$ , and  $N$  represents the number of antibodies in BCell#1.  $j = 1..M$  and  $M$  correspond to the number of antibodies in each B-cell#2.  $S_i$  represents the success ratio for each antibody  $i$ , and it can be calculated as the ratio of the count of correct responses (actions) divided by the total number of responses taken by this antibody.  $C_i$  represents the current concentration of antibody  $i$  in the B cell, and it should exceed the concentration threshold for the antibody to respond to antigen stimulation.

The first term of the right hand side of Equation (3) represents the stimulation activation level spread by other antibodies in the herding immune network; it can be calculated using Equation (1). The second term represents the suppression activation level spread by other antibodies in the same immune network; it can be calculated using Equation (2).

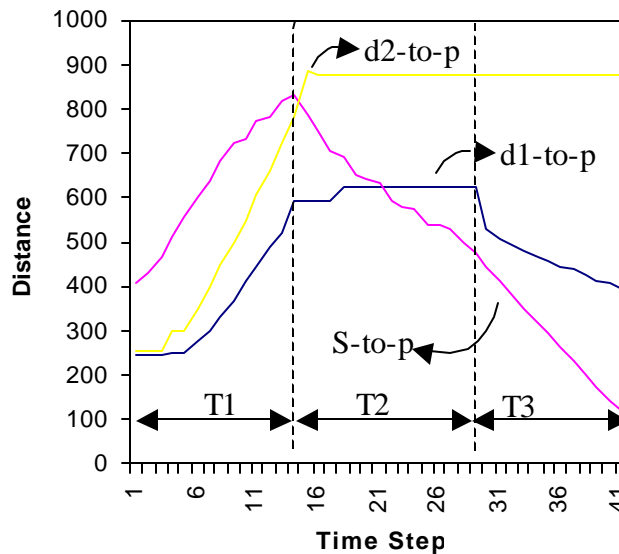
The third term represents the stimulation that an antibody receives from an antigen and it controls the balance of the immune herding network. Substituting with Equation (1), and (2) in Equation (3) we get Equation (4), which is the final form for calculating the concentration of an antibody.

We applied the simulated immune network to the work depicted on Section 4.1, with the same initial positions for all agents: D1, D2, and S. In the beginning, the network starts with equal antibody concentrations below the concentration threshold. As the antigen stimulates the antibodies, the network members start to use stimulation and suppression and change the antibodies' concentrations. Continuous interactions take place till the antigen is completely overcome. Each B cell (dog) has four antibodies (behaviors), which suppress different epitops of the antigen (sheep). These behaviors are moving up, down, left, and right with a single step which is considered as the speed of the dog. Figure 5 illustrates a run episode after implementing the immune network into the original dog and sheep problem. This figure can give a rough idea about the scenario that took place starting with the same initial conditions as the run in Section 4.1.

The episode starts with the sheep away from the pen, and at the same time running ahead in front of D1, and D2. While the herding process continues, both dogs do not have to move all the time. Instead, we can have a case of both dogs chasing the sheep, or another case where one dog is moving and the other is stand still in order not to disturb the progress done by that former one. With the aid of Figure 8 we can have an exact tracing for the motion of all agents in the running episode. In this figure we can notice that D1 stopped twice with different durations, and also D2 stopped once but for a long time till the end of the episode. During the early stage T1, both dogs are moving in trace of the sheep at the same time, until they reach a time step in which D1 stops and D2 moves for a few steps.

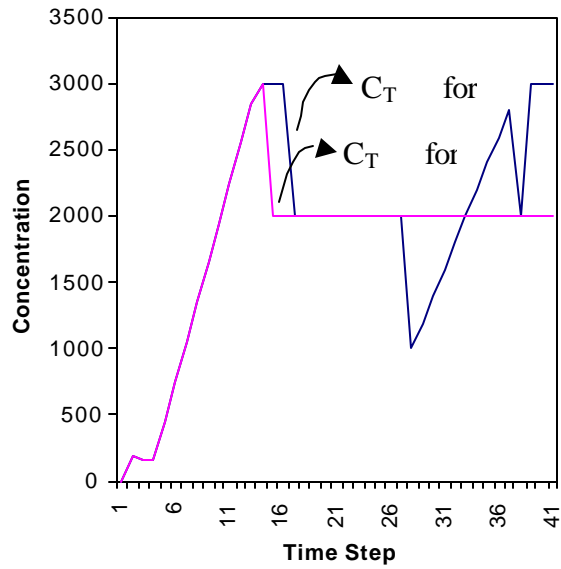


**Figure3.10** Episode Run Using Immune Networks



**Figure3.11** Episode Analysis

Figure7 reflects the changes made to total concentrations of B cell #1, and B cell #2 as time cycles progress. During time period T1 both B cell antibody concentrations were increasing equally until the right Ab is used. During time period T2, the concentration of antibodies in both B cells reaches a value that enables both dogs to overcome the sheep (Ag) behavior. According to concentration values D2 starts to move, while D1 is stalled, then for a few time steps both dogs are stalled. Despite being stalled, the antibody concentrations of both B cells are still interacting using stimulation and suppression.

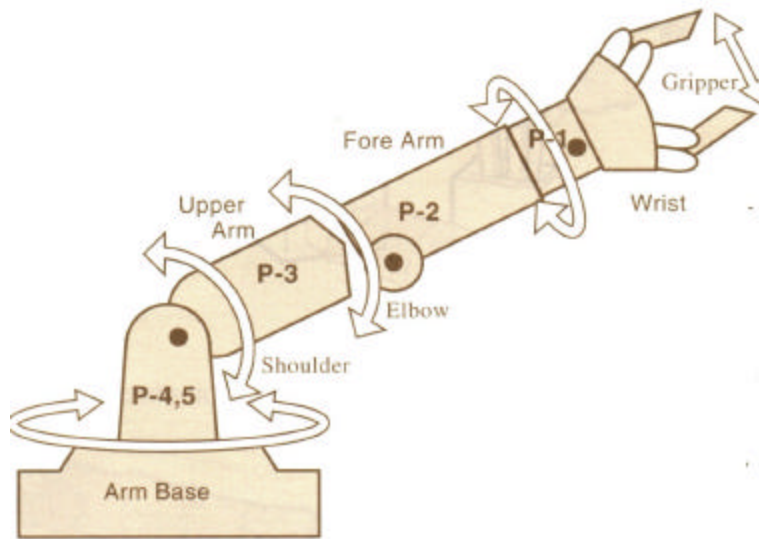


**Figure3.12** Antibody Concentrations

During T3, the continuous stimulation and suppression in the immune network will force d1 to move again driving the sheep to be within a certain range from the pen, Thus achieving the overall system goal in exactly 41 time steps. If we compare the results of the case study in section 4.1, and 4.2 we notice that using the immune network allows agents to achieve the main goal with minimum waste of time steps. This advantage was accomplished by the mutual stimulation, and suppression among elements of the immune network until the antigen behavior is completely overcome.



## 7. A Second Proposed Case Study: The Multi Joint Coordination Problem



**Figure3.13** A Robot Arm

This classical robotics problem considers the joints of a manipulator arm to be controlled by independent agents. Because of the tightly coupled nature of robot kinematics, a pre-described path for the end effector requires cooperative actions of the joint control based on transformed feedback signal. For example, a robot attempting to learn to throw a dart at a target will receive a quantitative feedback signal on the dart accuracy, and the joints must learn to apportion that signal in order to coordinate the motion of the joints. This problem is different from the dog and sheep problem used in the previous case study. In this case the joint behaviors are essentially the same, yet they are all independent and integral components of the same arm itself. We believe that applying our proposed neuro-immune network structure to it will improve the overall coordination performance of the robot arm, see Figure3.6.