

At the Water's Edge:
The Grid in Coastal Construction

by
Christopher S. Waltz

July 29, 1999
3:00 pm Room 400
Cowgill Hall
Blacksburg, Virginia

At the Water's Edge

The Grid in Coastal Construction

by

Christopher S. Waltz

A design thesis submitted to the Graduate Faculty
of
Virginia Polytechnic Institute and State University
in partial fulfillment of the degree of
Master of Architecture

July 29, 1999

3:00 pm

Room 400 Cowgill Hall

Blacksburg, Virginia

Approved:

Michael O'Brien

Chair

Mario Cortes

Dr. Joseph Wang

Abstract

The Outer Banks are a special place at the end of land and the beginning of water, and yet most of the houses built on these islands seem to take no notice. A drive down the beach road reveals house after house that are essentially suburban dwellings raised above flood level on piles. This project proposes that oceanfront homes should not be pale imitations of inland housing, but rather as unique as the environment in which they exist. The architect must design for the long term needs of the client to use elements dictated by the environment as integral parts of the design, thus creating a building that is both responsive to and reflective of the condition that occurs at the water's edge.

Acknowledgments

For their support, guidance and inspiration I would like to offer my thanks to the following people:

my committee for pushing me in directions that I would not have gone on my own, while maintaining their faith in my ideas.

my classmates who provided a creative atmosphere but were always willing to take time off to salvage our sanity with a beer.

the gang at TOTS for giving me something to talk about besides architecture.

Steve Howe, Geoff Downes, Roger Waters, Dmitri Shostakovich, Ian Anderson and Gustav Holst for serenading me while I wrote.

my family for their unfailing support through an atypical college career.

Reilly for keeping my chair warm during those all-nighters.

Kirsten, “my everything, my all, my other self” - I couldn’t have done it without you.

Table of contents:

Abstract	3
Acknowledgements	4
Table of Contents	5
Program	6
Site	7 - 15
Grid	16 - 22
Structure	23 - 29
Plan	30 - 36
Envelope	37 - 43
Findings	44
Endnotes	45
Image Credits	46
Works Consulted	47 - 48
Vitae	49

Program

A couple from Raleigh, NC is interested in building a beach house on the Outer Banks. They are in their mid-40's with two children and plan on using the house as a vacation getaway several weeks of the summer and occasionally in the off-season until they retire there in about 20 years. When not in use by the owners, it may be rented to vacationers. Some of the desired rooms include:

- Living area
- Dining area
- Full Kitchen
- Television area
- Space for a piano
- multi-purpose music room/library
- Master suite with full bath
- Guest suite with full bath
- 2 other guest rooms with shared full bath
- Full-sized laundry
- Indoor and Outdoor Storage space
- Deck Space
- Boardwalk to the beach
- Parking for several cars

Site

The site provides the context for a building, and with this project, the natural and man-made surroundings played a major role in the design . Site concerns such as weather, view, solar orientation, surrounding buildings and topography were carefully considered for every aspect of design, from placing the building on the site to determining building materials, wall thicknesses, window protection and roof slope. Local buildings were studied to determine which traditional site responses are still applicable today, and which could be updated with new materials, technology, or ideas.

Location

The Outer Banks are a narrow strip of barrier islands along the North Carolina coast that were created about 15,000 years ago as sea level rose while the glaciers retreated. They are known as “barrier islands” because they protect the primary shoreline from dynamic marine processes such as wave action and wind erosion.¹ They can be thought of as giant sandbars that are wholly at the mercy of wind and water and can change very quickly in unexpected ways. With the growing popularity of the beach, barrier islands have become popular places to live and vacation, and despite man’s attempts to control them, they retain their volatility.

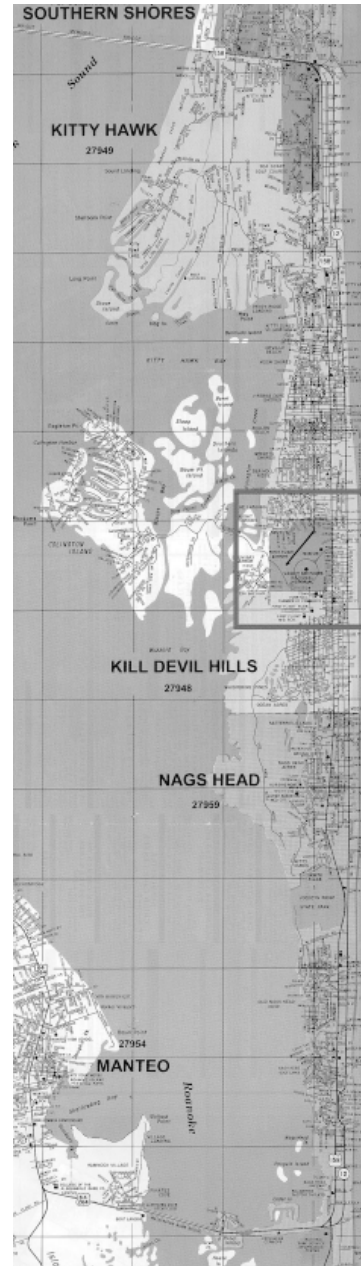
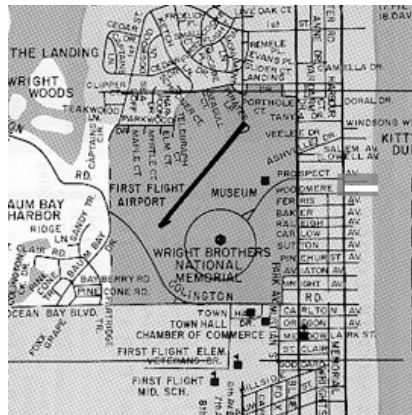



All that remains of a house in Louisiana after Hurricane Andrew. The connection between the foundation and walls was obviously inadequate as the upper floor and roof of this house were found over 150 feet down wind.



A piece of wind-driven plywood piercing a royal palm after Hurricane Andrew. The architect needs to take precautions against such wind-borne projectiles by using thicker plywood wall sheathing and designing adequate glazing protection.



An aerial view of two Florida subdivisions immediately after Hurricane Andrew. The houses still standing in the background are proof that designing against hurricanes can help minimize damage.



A gable end blown out by Hurricane Andrew. When a building envelope is breached by high winds or projectiles, internal pressurization can “pop” out wall or gable ends that are not properly connected. While the structural damage to this house is minimal, the ensuing water damage rendered the house a complete loss.

Hurricanes

While building on the Outer Banks has always been a risky endeavor, the greatest threat to housing comes each year during the period from August to November. This is hurricane season, and because of the way the Banks jut out into the Atlantic, they are in a prime position to be hit by these great storms as they move up the eastern seaboard from the Caribbean. Hurricanes pose a triple threat to housing with high winds, storm surge and heavy rains, causing millions of dollars in damage in the United States each year. While structural damage is a real concern, the majority of monetary loss comes from water damage that is made possible by envelope breaches caused by wind and wind-borne projectiles. Extensive studies after Hurricane Andrew in 1992 show that hurricane damage can be substantially reduced if the architect pays particular attention to window protection, roof geometry, and height above expected storm surge.

Island Migration

When building on the Outer Banks, it is important to realize that they are inherently dynamic. The Outer Banks are forever moving inland through a process often termed “beach erosion,” but best described as “island migration.” The exact rate of migration depends on the prevailing local conditions, both natural and man-made, and rates can vary from as little as 2 feet per year to as much as 20 feet per year.² Early settlers lived with this phenomenon by building on long, narrow sites and periodically moving their houses inland as the ocean approached. Unfortunately, overdevelopment and the resulting lack of available land has largely ended this practice and new houses are built on small lots that are in immediate danger of “going to sea.”

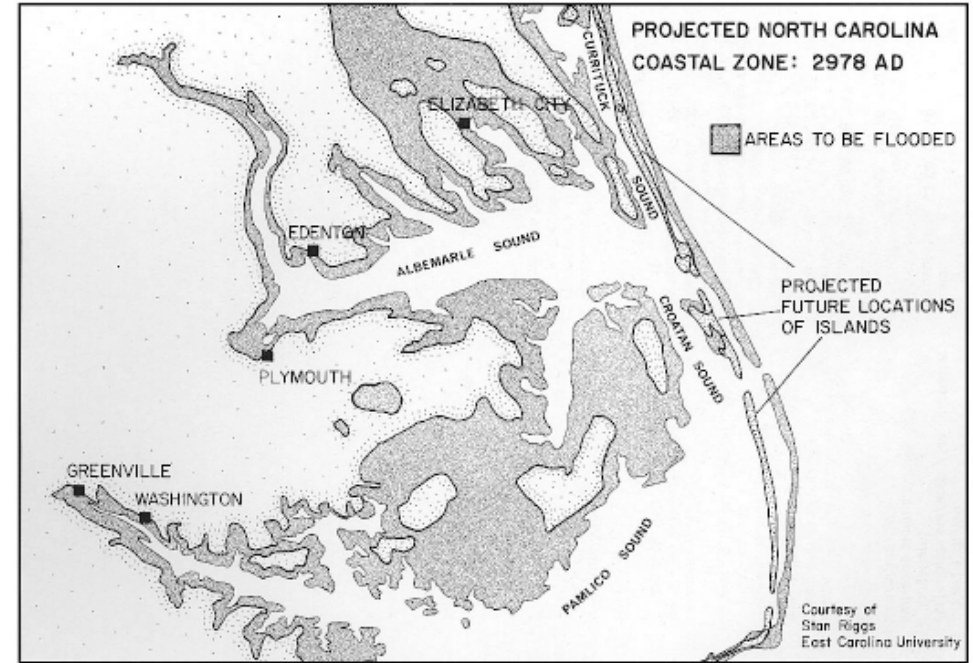

The long-term outlook for the North Carolina coast. Since this study was performed, global temperatures have risen faster than expected turning this prediction into a conservative estimate.

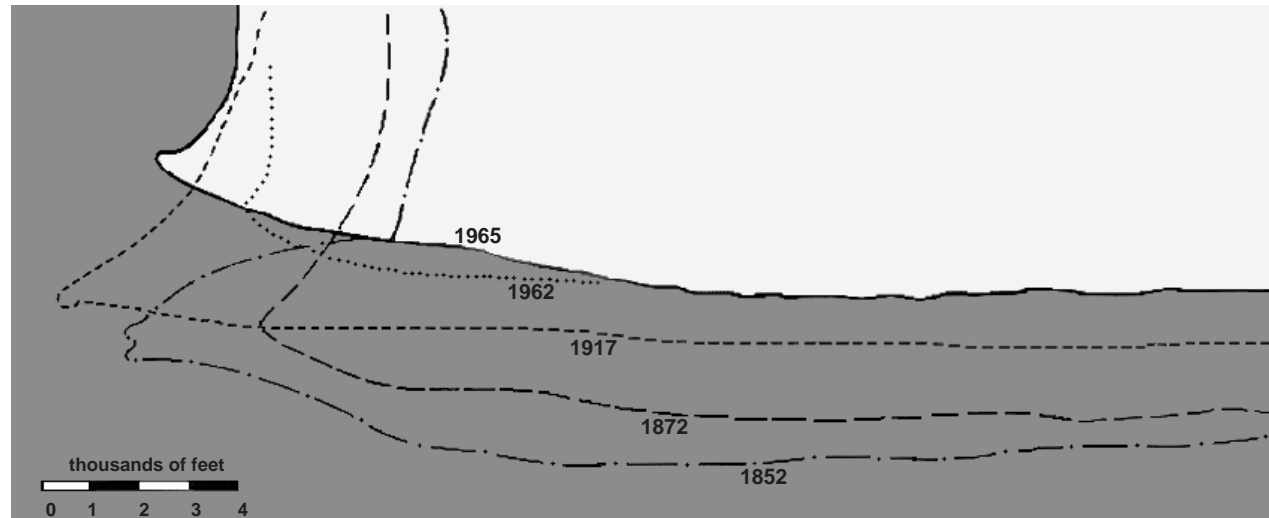

Shoreline change at Cape Hatteras from 1852 to 1965. This type of movement is typical of barrier islands and needs to be anticipated by the architect.

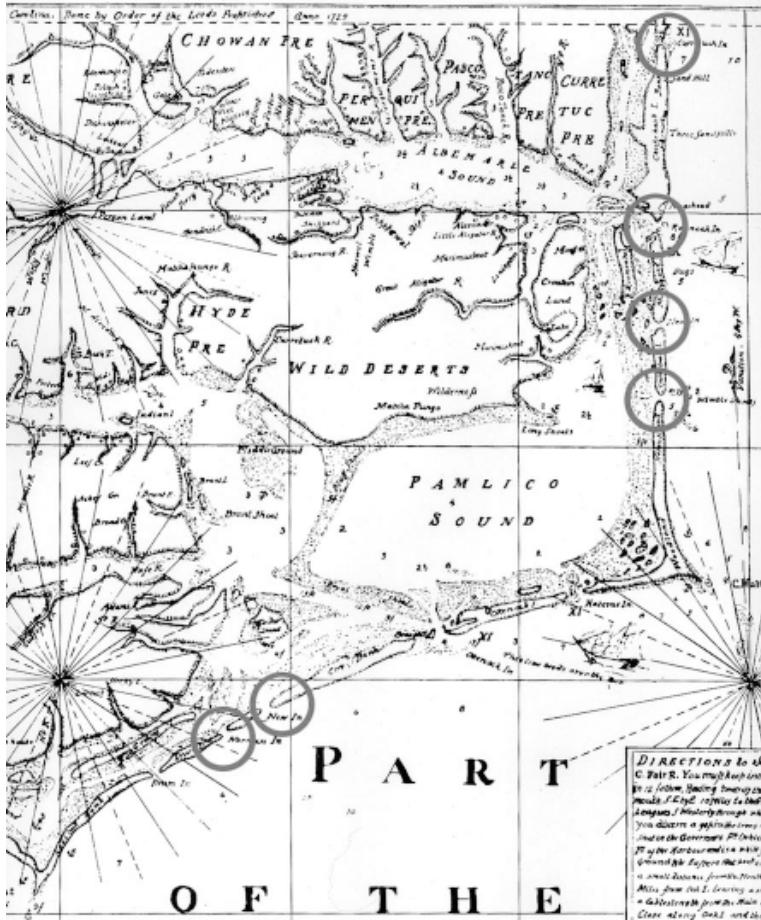

The Outer Banks in 1738. The blue circles represent inlets that have since closed.

Inlets

Besides the ever-encroaching shoreline, buildings on the Outer Banks must also contend with inlet formation and migration. Inlets are the channels between islands that are generally formed during hurricanes or severe storms when too much water is pushed into the sound. If existing inlets do not allow the water to escape fast enough, a new inlet is cut from the sound side. Once formed, the inlet migrates laterally up or down the island destroying all structures and property in its path. Twenty-five major inlets have been cut since 1585 while dozens of temporary cuts have come and gone without appearing on maps or acquiring names.³ Changes and movement occur so frequently that there is hardly a section of the entire Banks which has not been under water at one time.

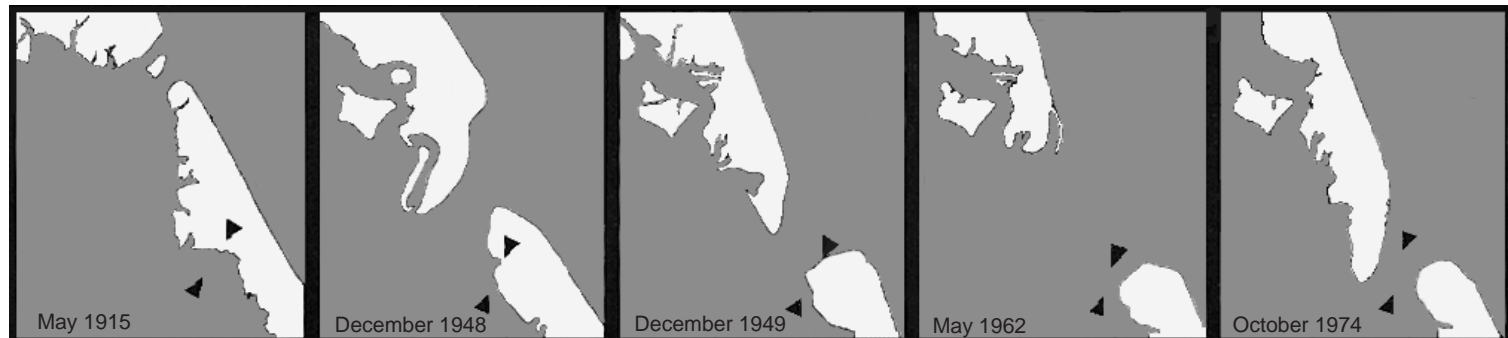

The migration of Oregon Inlet from 1848 to 1974 with black arrows indicating its 1974 location on each of the maps. This inlet cannot be found on the old map pictured above as it did not open until 1846. Since then it has moved almost two miles southeast along the island.

Site

An oceanfront site was chosen by carefully considering natural and man-made factors in order to minimize the risk to both life and property and maximize the experience of living on a boundary between land and water. The primary dune is approximately 15 feet high and should provide good protection from severe storms and hurricanes. The dune's heavy vegetation combined with an average coastal migration rate of only 2 feet per year indicates a high level of stability for this section of beach. There are no nearby inlets threatening migration and the width of the island is large enough to make a new inlet cut very unlikely.

The site is located in a residential area and abuts a beach access to the south and Route 12 or "the beach road" to the west. The surrounding houses feel like they would be more at home in a suburban subdivision and lack any connection to the location. The land across the beach road is currently undeveloped and should remain that way as it is owned by the United States Department of the Interior and marks one entrance to the Wright Brothers National Memorial. If a severe storm warrants evacuation, the main bridge off the island is only 6 miles away and should be able to be crossed before the mass exodus from further down the island creates long delays.

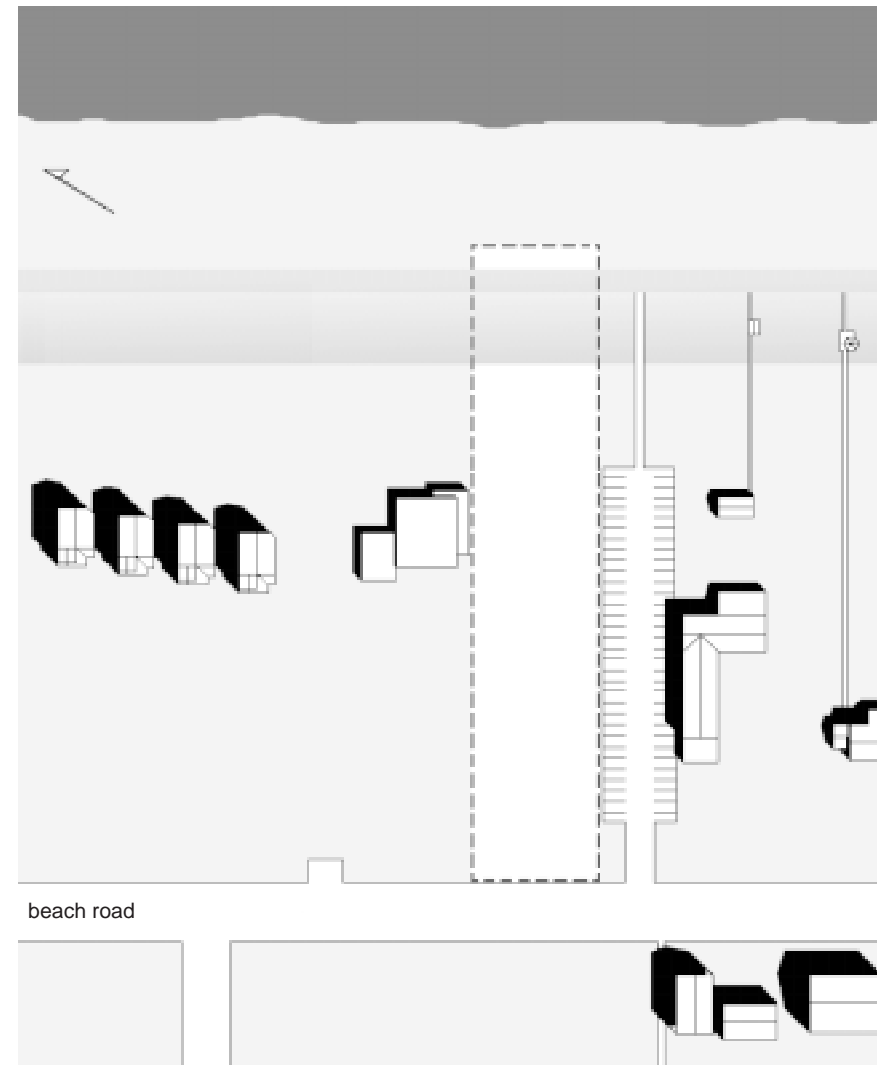

Site map and photo looking from the beach road toward the ocean.



Although the lot size is 100 feet wide by 500 feet long, much of it is unbuildable due to environmental factors and code setbacks. Building on or in front of the dune line is prohibited, and good practice suggests using a 100 year migration setback to protect the house against island migration. For this site that equates to a 200 foot setback measured from the front of the primary dune. Side and front yard setbacks required by code further reduce the available building area.

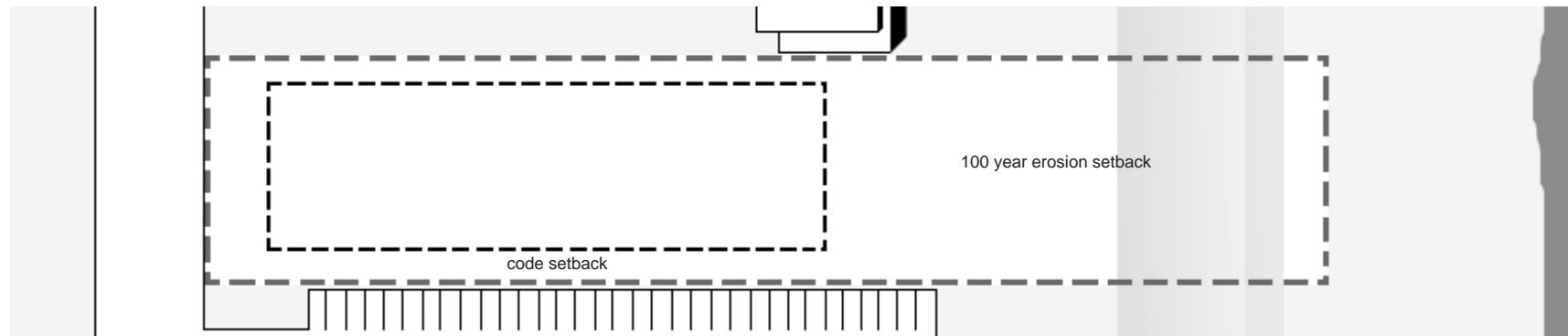

In the vertical direction, code allows a 42 foot maximum height in order to limit exposure to winds and keep the building profile along the ocean aesthetically pleasing. The lowest structural element must be located above the 100 year flood level of 8.80 feet, though raising it higher will give better protection from flooding and lower flood insurance rates. The final siting of the house was determined by design concerns such as connection between land and water, solar orientation, view, street noise, privacy and relation to existing buildings.

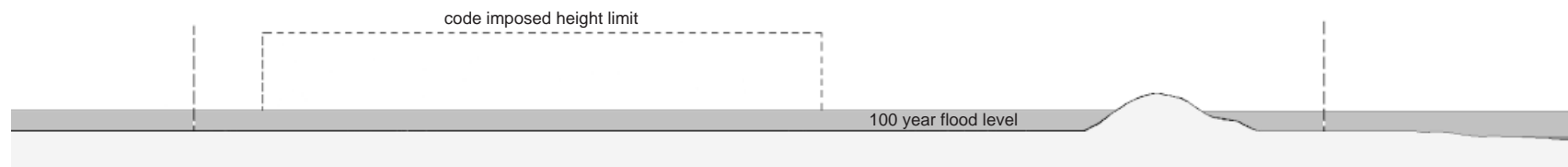

Site Response

The houses on this page represent the traditional homes found on the Outer Banks and contain many similar elements that are a direct result of environmental factors. Taken together, these elements help define a building style that is both aesthetically pleasing and functional. Some of these elements include:

- a basic rectangular plan that allows the building to act as a unit under high winds and minimizes localized pressures normally associated with abrupt changes in geometry.
- a large surrounding covered deck that “buttresses” the house, provides sun-shading and acts as a sacrificial layer of protection from wind-borne debris during severe storms.
- hip roofs that have an inherent structural stability due to their framing geometry and are often better constructed because of their relative complexity.
- piles that raise the house above flood level and are adequately braced for lateral loads, especially perpendicular to the ocean.
- long lots that allow for movement of the house as the beach migrates closer.
- small windows with hurricane shutters for both sun and projectile protection.



House in Nags Head. This is one of the oldest surviving houses on the Outer Banks and a good example of the points discussed to the left. Built on a long, narrow site, it has been moved back from the ocean three times in the last 100 years.



Two houses on the same lot in Kill Devil Hills. The one closer to the ocean was probably built first and better exemplifies the elements discussed at left.



A bed and breakfast in Nags Head. Built on the ocean in 1932, it was moved across the beach road in the 1980's to avoid the encroaching seawater.



A typical house under construction in Nags Head. The piles have no relation to the building other than to raise it above flood level, and the standard balloon frame must rely completely on mechanical fasteners to tie it to the foundation. This is a good example of what is to be avoided in this project.

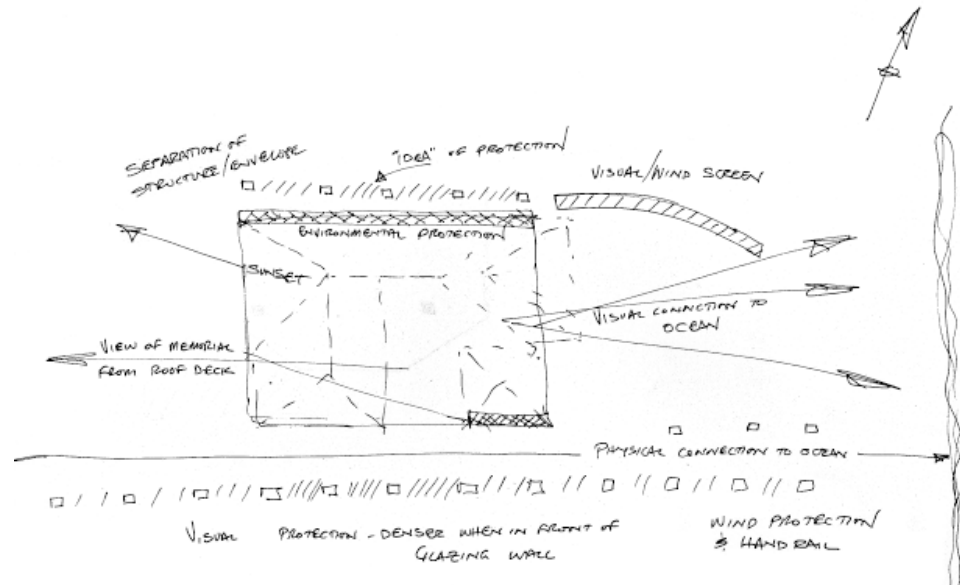

An early idea for the basic layout of the house emphasizing the connection between land and water and the various site lines. The schematic lines above and below the house indicate zones of exterior protection for wind, sun and privacy.

Architectural Programme

Considering the site-related issues along with the requirements of the program, a basic solution was conceived based on the following three statements:

- the house will provide a physical, visual and symbolic connection between land and water.
- the house will use traditional materials in new ways to create a house that is similar to its surroundings in vocabulary but different in expression.
- the house will use piles as an integral part of the design, not just to raise the house above flood level.

Grid

The grid has been used by architects in many different ways depending on material, intent and style. Its popularity comes from its ability to organize and regulate, provide a scale, and relate each part of the building to the whole. Before designing the column grid for this building, several notable examples were investigated to seek insight into the advantages, typologies, characteristics and limitations inherent in a grid.

“All the buildings I have ever built, large and small, are fabricated upon a unit system. Rhythm, consistent scale of parts, and economy of construction are greatly facilitated by this simple expedient...”⁴

- Frank Lloyd Wright

Palladio

The Villas of Andrea Palladio present a good example of the wall grid, which he used to create the symmetry and proportion for which his villas are renowned. Most of Palladio's grids use a 3, 5 or 7 module rhythm along the transverse axis to provide inherent bilateral symmetry and create a large central room surrounded by smaller rooms. Some of the grids begin to anticipate a tartan, but never quite achieve it, possibly because it would imply several secondary axes that would weaken the main axes and destroy the hierarchical layout that is so important to the design. The structural necessity to locate masonry bearing walls on top of each other causes the plan to remain the same on each level and also implies a simple roof to cover the entire building. Palladio generally used a single, large hip roof to help amplify the volume of the central space and exaggerate the vertical emphasis created by the wall grid.

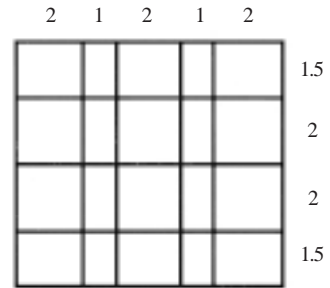

The **Villa Foscari** uses the smaller interior modules of the 2:1:2:1:2 rhythm to provide a place for the interior stairs and create a cross shaped central room that reinforces the transverse axis. The additional module at the front of the house allows the loggia to form a logical extension of the interior structure.

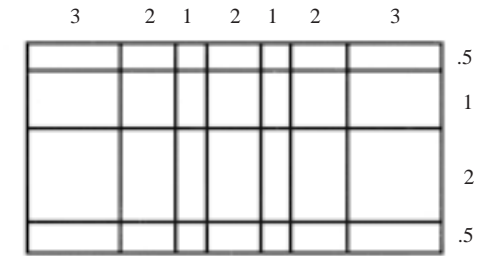

The **Villa Pogliana** uses a seven module grid that creates a wider house with the typical strong axis of symmetry, but a weaker transverse axis. The grid begins to approximate a tartan with the narrow modules occupied primarily by interior and exterior stairs.

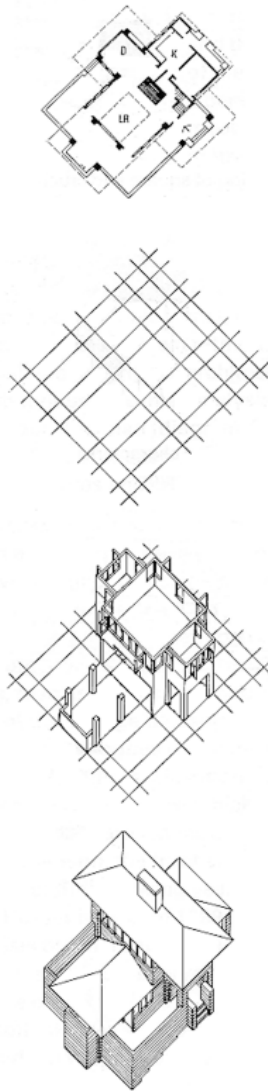

In the **Ross house** (1902), the structure is placed along the edges of the larger modules while the smaller ones are used mainly as circulation paths. The cruciform plan with its two strong axes is inherent in the grid layout and reinforced through the room arrangement.⁷

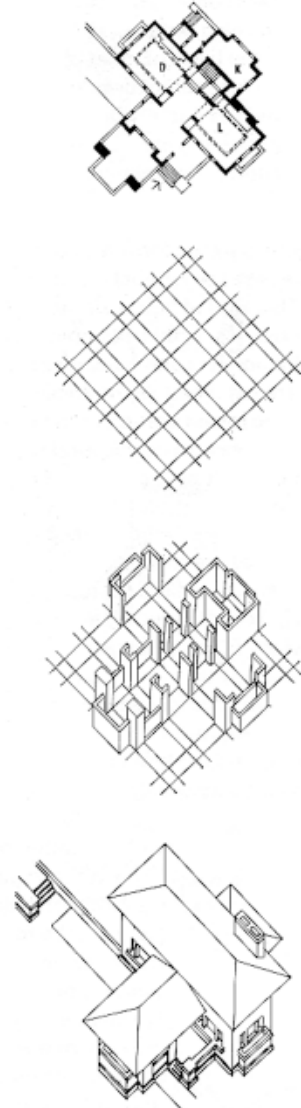

Wright's **Barton House** (1903) uses the narrow modules exclusively for structure and the wider ones for the main rooms and stairs. All the larger modules are approximately the same size, but the main rooms take different shapes through the addition of one or more smaller modules.⁸

Wright

Frank Lloyd Wright experimented with many different types of grids during his career, but the one that is most relevant to this project is the tartan grid used during his Prairie Period. This type of grid uses an alternating pattern of wider and narrower strips that creates a series of different sized modules whose exact layout and use are determined by the particulars of each project. The larger modules are used for major spaces such as the living room, dining room, kitchen and bedrooms, while the smaller modules are well suited for the placement of structure, stairs, fireplaces, planters and other support element.⁵ By expanding the grid outside the house, spaces are provided for porches, verandas and balconies that feel like logical extensions of the inner structure rather than parasitical afterthoughts. The design of the roof is also facilitated by the grid as several parallel lines of structure exist in two directions to allow for a more complex roof.⁶ The tartan grid allowed Wright to integrate a collection of parts into a harmonious whole and then derive the exterior form of the building from these internal spaces.

Corbusier

Le Corbusier is one of the pioneers of the modern column grid that moves the focus from the grid lines to the vertices. This simple move allows the plan to change freely from floor to floor and emphasizes the horizontal rather than the vertical planes. Exterior walls become curtain walls and shed their load-bearing responsibility allowing for long “ribbon” windows and even entire elevations of glass. No longer restrained to the grid lines, interior walls act only as spatial dividers that can easily curve, stop short of the ceiling, or be left out altogether as the ultimate expression of the “free plan”. Corbusier would sometimes conceal his columns in the walls, but often left them exposed to help define and enhance the spaces. By building with reinforced concrete, Corbusier could move the occasional column slightly off grid to create a condition that actually reinforced the pattern by the exception pointing up the rule. The column grid seems to work best with a flat or simple pitched roof, with Corbusier opting for the former in order to provide another of his five points of architecture, a usable roof-garden space.

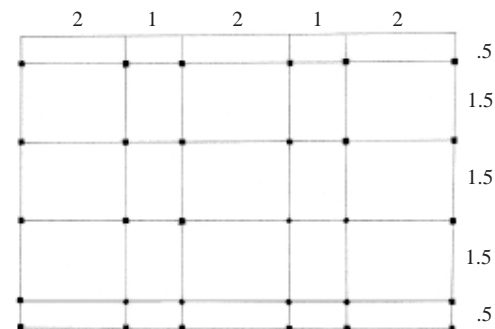
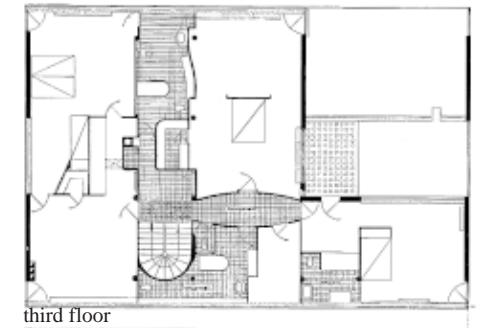
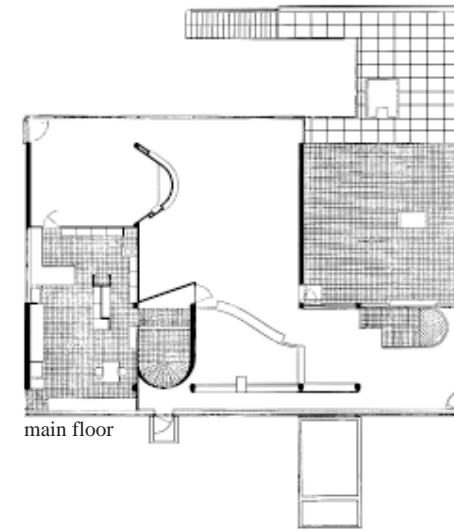
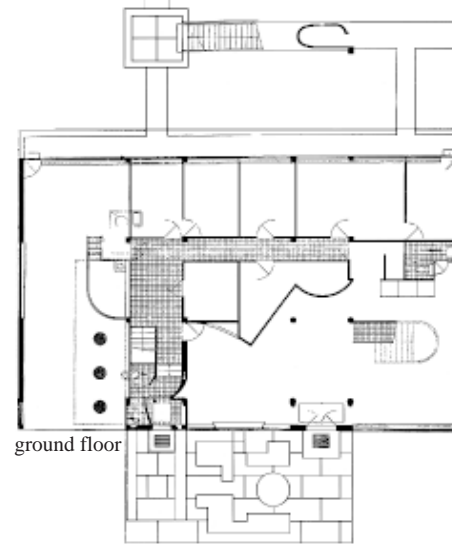

The **Villa Stein** at Garches (1927) is a good example of a rectangular Corbusian grid. The 2:1:2:1:2 layout is reminiscent of a Palladian grid and an in depth comparison of Villa Garches and Villa Foscari can be found in Colin Rowe’s essay “The Mathematics of the Ideal Villa.” The smaller modules create places for entry, horizontal and vertical circulation and bathrooms while the larger modules are combined or divided on each floor as use dictates. Unlike the Villa Savoye, all the columns are on grid and the building as a whole maintains a dispersed, egalitarian layout with no single strong axis. The walls interplay with the columns but maintain a recognizable correspondence to the grid while the shape of each column, square or circular, is dependant on its relationship to the walls.

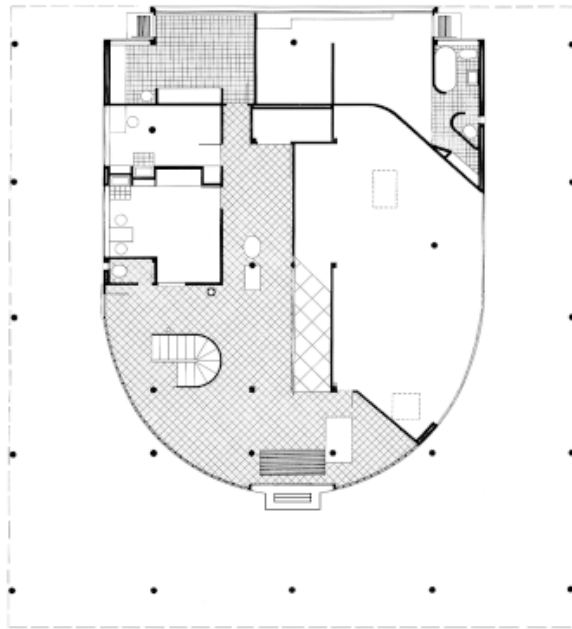

ground floor

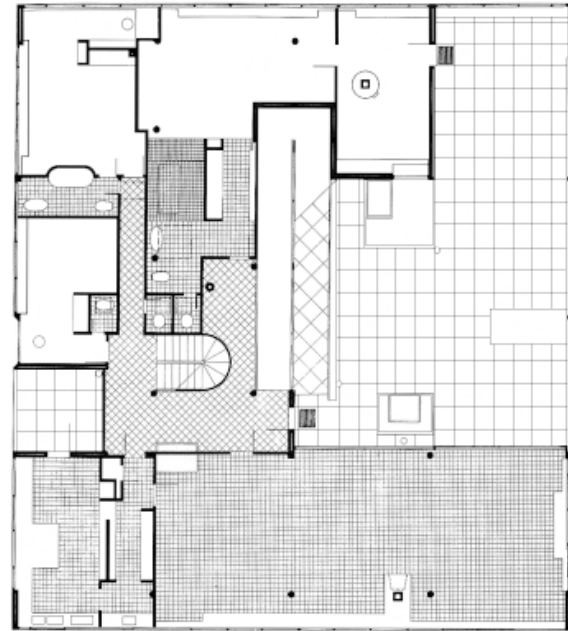

main floor

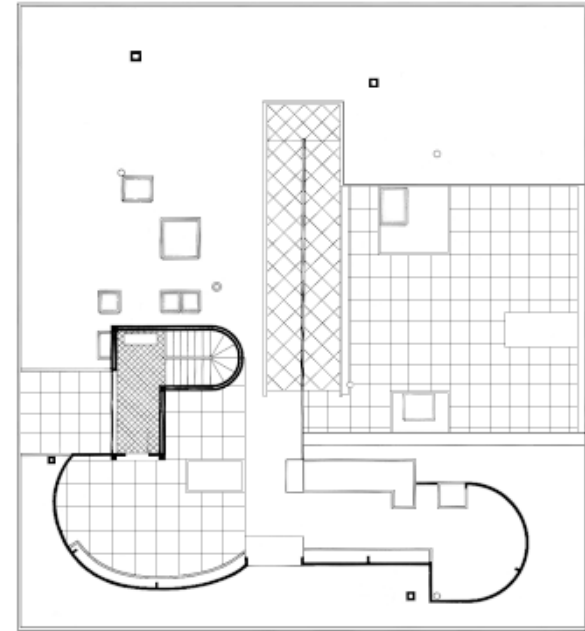

roof garden

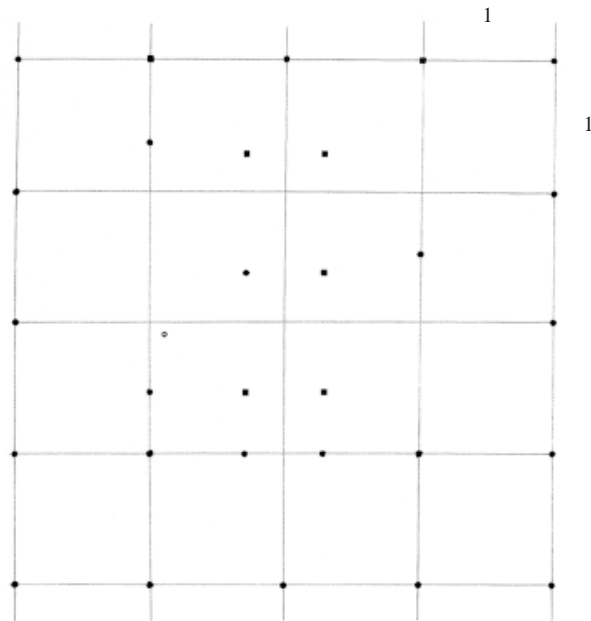

The **Villa Savoye** (1929-31) is considered Corbusier's ultimate realization of the use of the column grid. The original design was based on a 4 by 4 square grid of 5 meter modules, but was built with a 4.75 meter module to save money.⁹ The grid shifts around the interior ramp, allowing for vertical movement and creating a dominant central axis that is reinforced by placement of the entry. Freestanding columns are used to mark spaces, create thresholds and even carry mechanical systems and range from square and cylindrical concrete to hollow circular steel. The walls are placed according to program and circulation needs and are wholly independent of the structural grid. Corbusier located the main living area on the piano nobile to permit "distant views of the horizon from where you can see the countryside so much better than if you had stayed on the ground."¹⁰

The Grid in this Project

The grid exists at several levels throughout the house and is based on the column grid to the right. The basic module is 8 feet with secondary modules half (4 feet) and one-and-a-half (12 feet) times that size. This division allows for a variety of room sizes while maintaining reasonable spans for the structural members. The pattern approximates a tartan with the smaller bays representing zones of movement and the larger bays becoming the major rooms. A strong central axis reinforces the connection between land and water, but does not act as an axis of pure symmetry, as the bays on either side of it are divided differently according to the needs of the program.

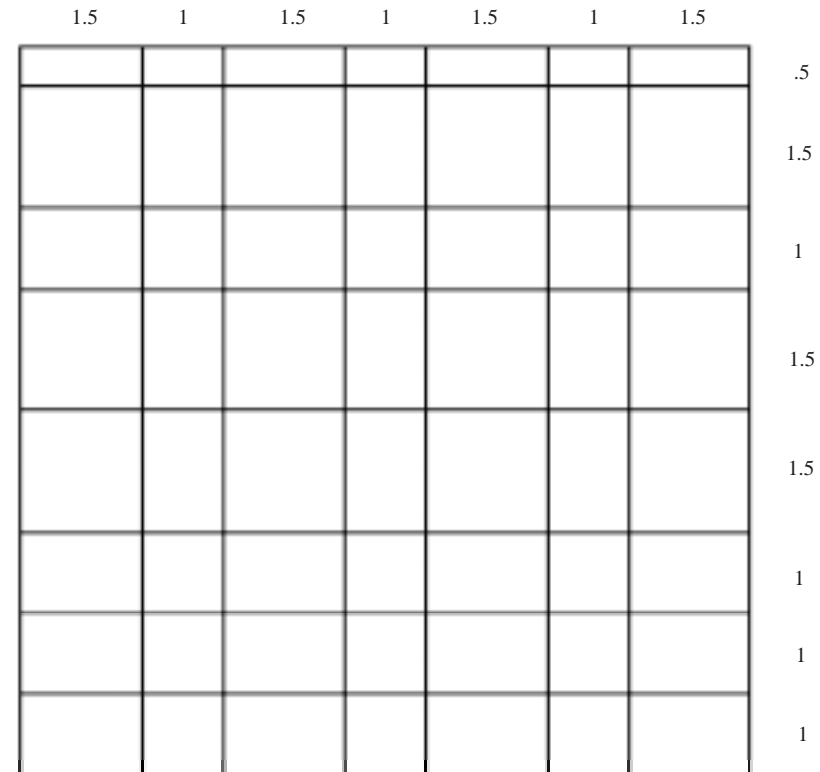

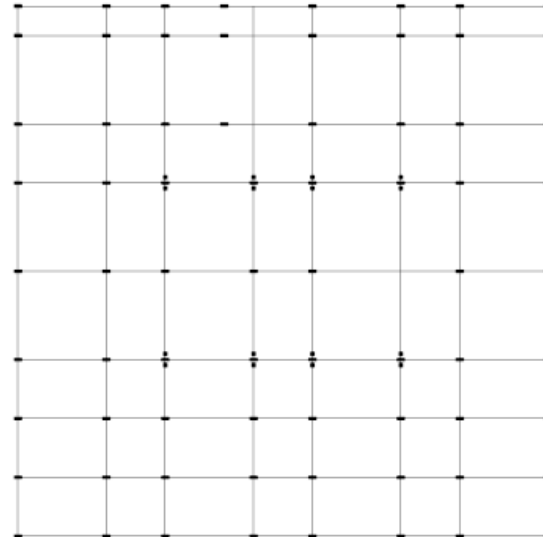
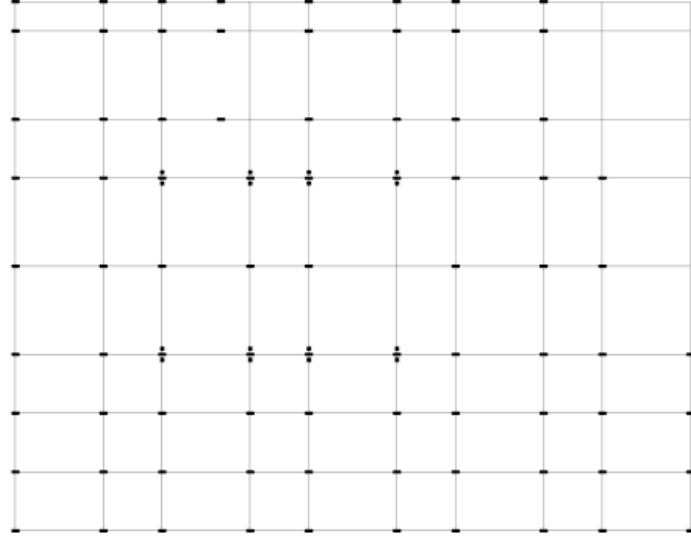

Because the house must be raised above flood level, the columns have an enormous impact on the exterior appearance of the house. The grid consists of continuous columns that extend their presence inside and use it to define space. Each major room is bounded by four columns that provide a subtle yet obvious partition. Public spaces share columns, representing the interaction and accessibility of the rooms, while private rooms have all four columns to themselves. Secondary rooms and circulation paths have no such distinctions and can have one, two, three or no columns.

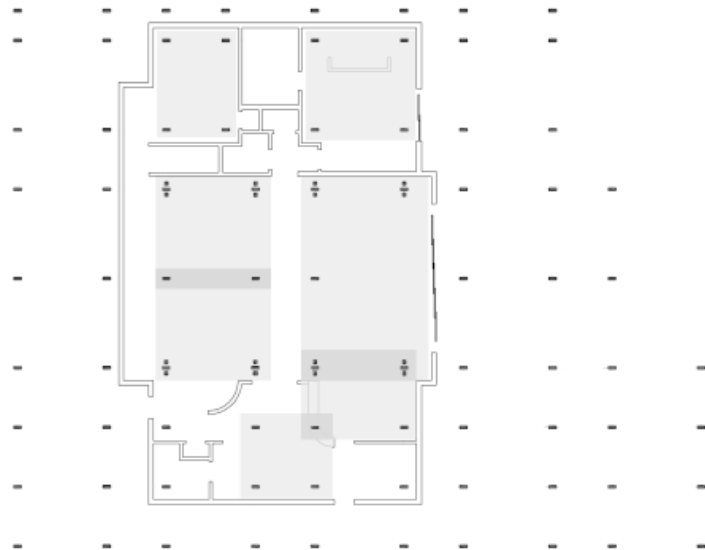

first floor plan and column grid

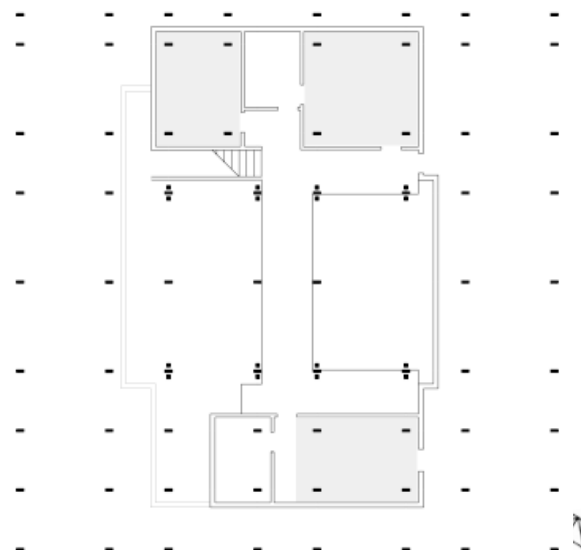

second floor plan and column grid

Structure

“Structure as ornament” is an underlying idea in the design of the house. The simple combination and repetition of the columns and beams creates a three-dimensional grid that is both functional and attractive.

“It is interesting to get so much variety when you have, for example, from a structural standpoint, permitted only a system of posts and beams of absolute rigor.”¹¹

- Le Corbusier

Structure

A wooden column grid with paired beams forms the basis of the structure. The beams are paired to avoid eccentric loading while providing additional lateral support along the length of the columns. This simple system uses repetition to regulate the space and provide a unique aesthetic. The columns and beams are made of heavy timber, while secondary framing members like joists and rafters are dimensioned lumber.



Besides their functional purpose, paired beams also create a place for unobtrusive overhead lighting.



The **Wright Guest House** (1987) by James Cutler uses a simple structural grid with a narrower bay for circulation and a wider bay for living space. The colonnade provides separation between the spaces while the paired beams lend a feeling of enclosure to the walkway.

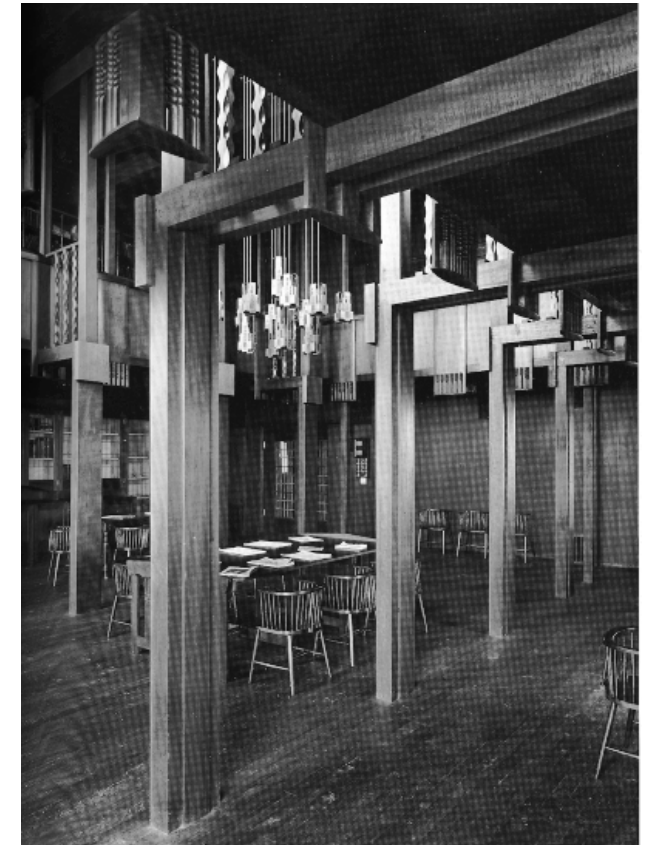

The library of the **Glasgow School of Art** by Charles Rennie Mackintosh (1898). Each column is stiffened with a wooden facing that extends up both sides to give a bearing surface to the paired beams. The balcony is pulled back from the columns to allow more light into the area underneath.

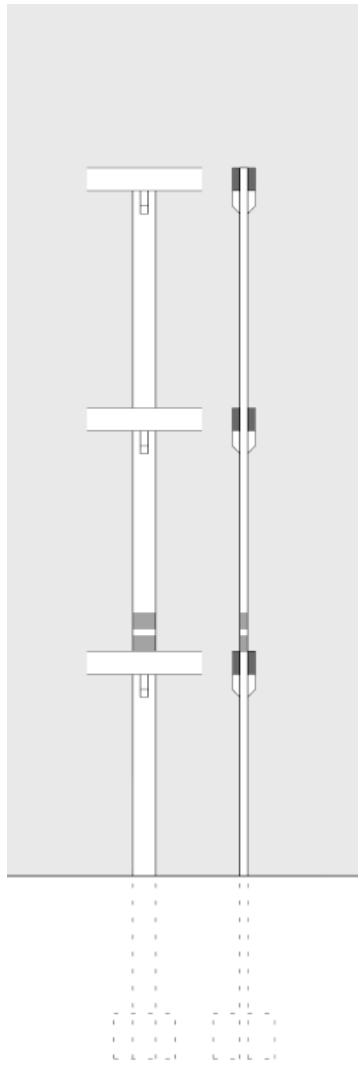

The rectangular shape of the main columns helps orient the house towards the ocean while reducing the visual interference along the primary axis. The columns have three sets of “capitals” that give scale to each level while providing a bearing surface for the floor beams above.

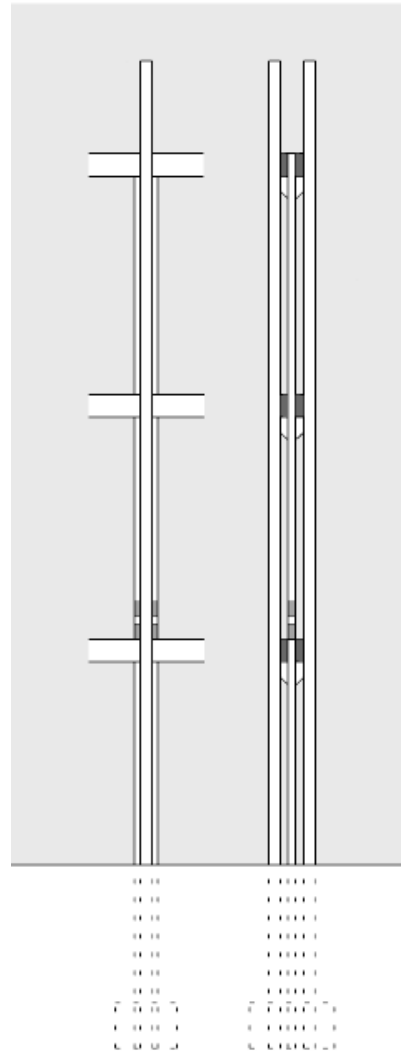

Grouping the columns allows the beams and bearing blocks to brace the roof columns for added lateral support. Aesthetically, the grouped columns create a hierarchy that reinforces the importance of the great room and gives a feeling of additive strength.

The column grid is made up of single rectangular columns that support the floor loads and paired square columns that carry the central roof trusses. All the columns extend from the foundation to the roof to tie the structure together for improved lateral stability against high wind.

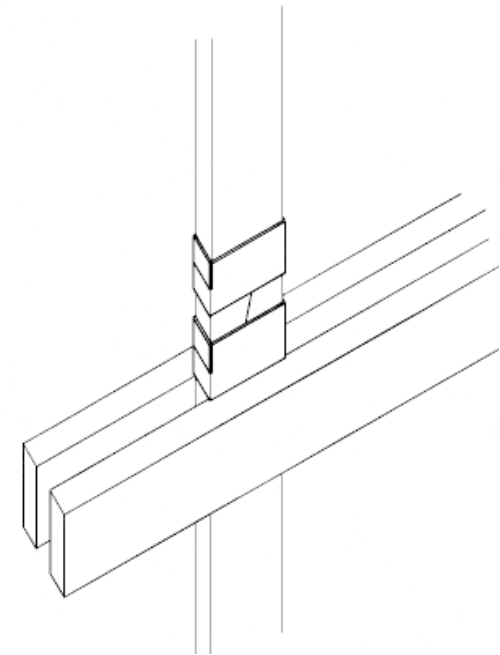

A splice has been designed in the likely event that timbers of sufficient length are not available for the columns. Besides its obvious structural purpose, the splice acts aesthetically as a column “base” for the first floor.

The two kinds of column are clustered in the great room in the manner of gothic cathedral columns. The individual load path of each column is clearly expressed while the grouping inspires a feeling of additive strength and soaring verticality.

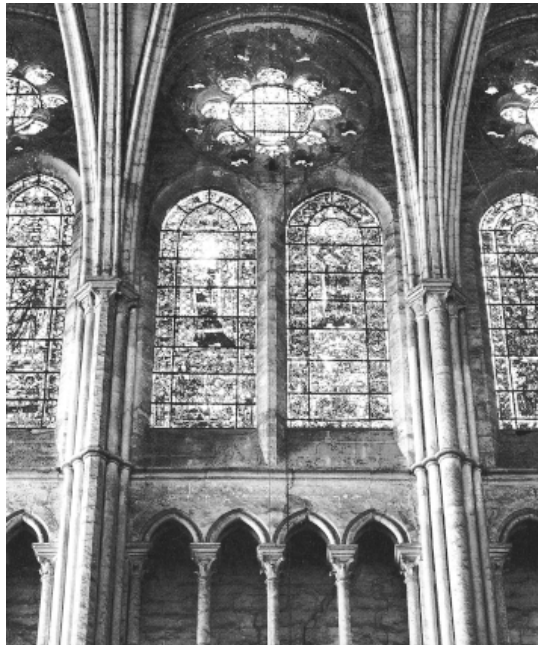

Chartres Cathedral nave (13th C.) A good example of the bundled columns often used in gothic structures. This technique not only helps to emphasize the vertical, but provides a clear load path from the ceiling to the floor.

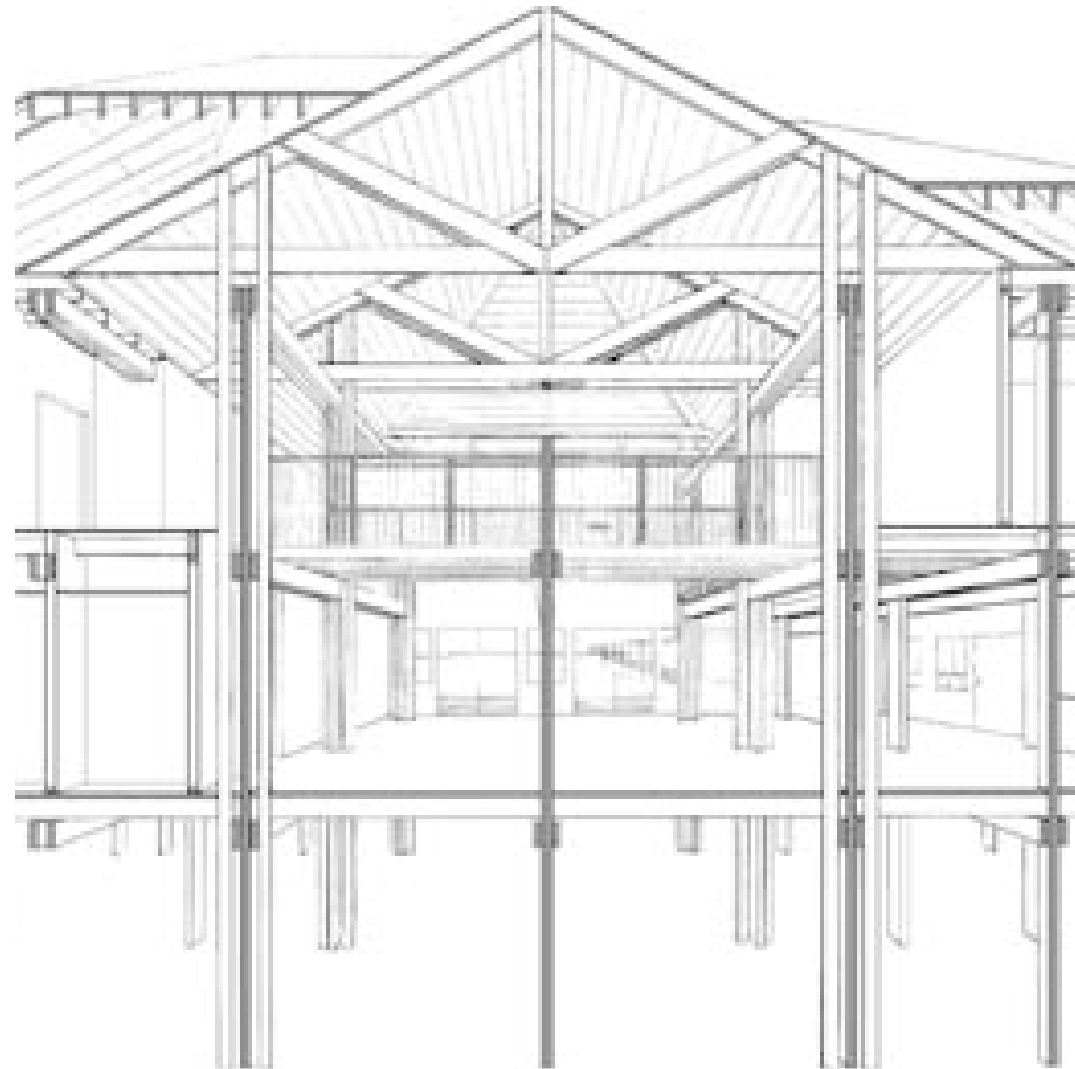

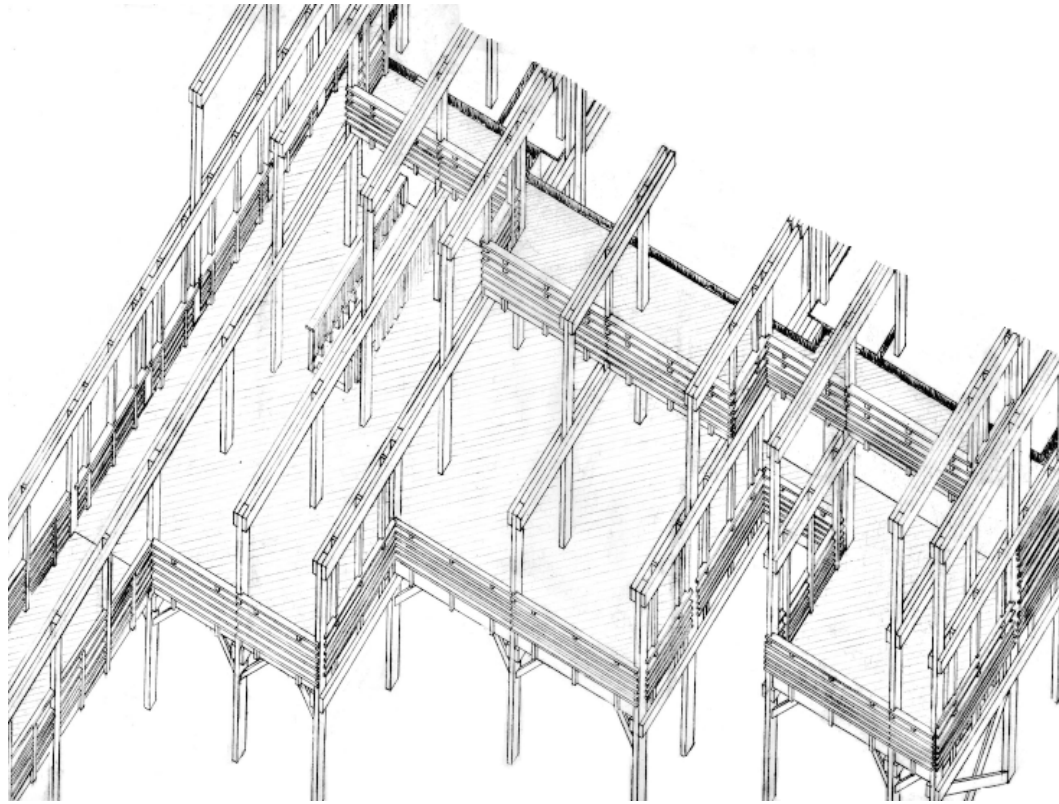

The open expression of the three dimensional grid shows that this house is not simply a platform dwelling built on stilts, but rather a building whose structure is integral to the design. The beams and columns extend beyond the envelope to mark the exterior domain of the house and create inbetween spaces that provide a transition between inside and outside. These transitional “rooms” allow activity to freely flow out onto the deck while staying within the protective domain of the house. The exposed exterior structure also provide places to hang hammocks, swings, laundry, badmiton nets or anything else that the owner desires.

Lateral Bracing

Lateral bracing is critical to the well-being of a house in a hurricane zone as horizontal loads from high winds, storm surge, and wind-borne debris put a severe strain on the vertical support members. Shear walls are the best, but can only be used above flood level where they will not interfere with the flow of storm surge. Sheets of 3/4 inch plywood attached to the wall studs form an effective shear wall that resists lateral thrust and also strengthens the envelope against puncture by wind-borne debris. Below flood level knee-bracing and cross-bracing work well to provide lateral support with maximum permeability for wind and water.



A house with insufficient lateral bracing after a hurricane. The shear walls have protected the interior, but a lack of bracing below flood level caused major damage to the piles.

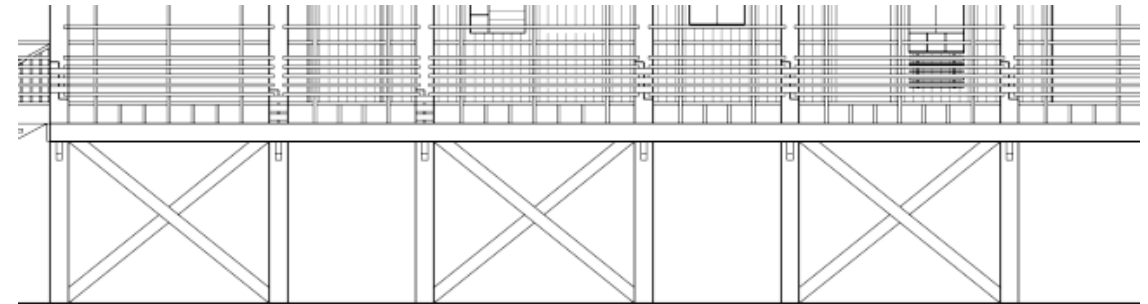

Cross-bracing is used perpendicular to the ocean to help withstand the force of a tidal surge. Their obtrusive nature has been used to advantage to help mark the domain of the house and add to the feeling of solidity of the structure.

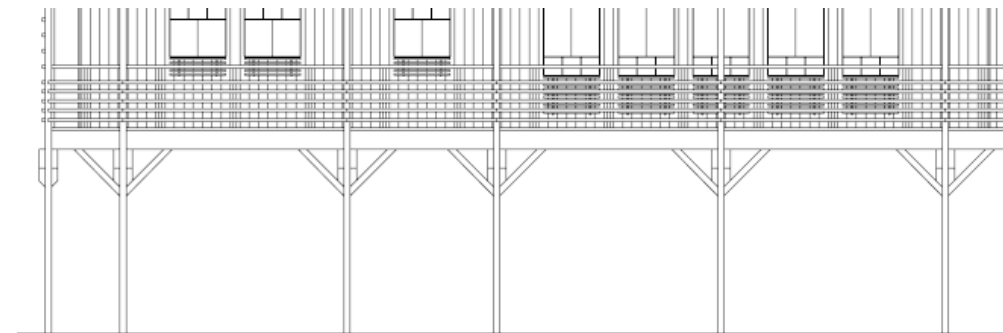

Knee-bracing is used parallel to the ocean to minimize the obstruction to flood waters and limit the visual impact when looking towards the ocean. It provides lateral support against wind and any debris that might hit the house during a hurricane.

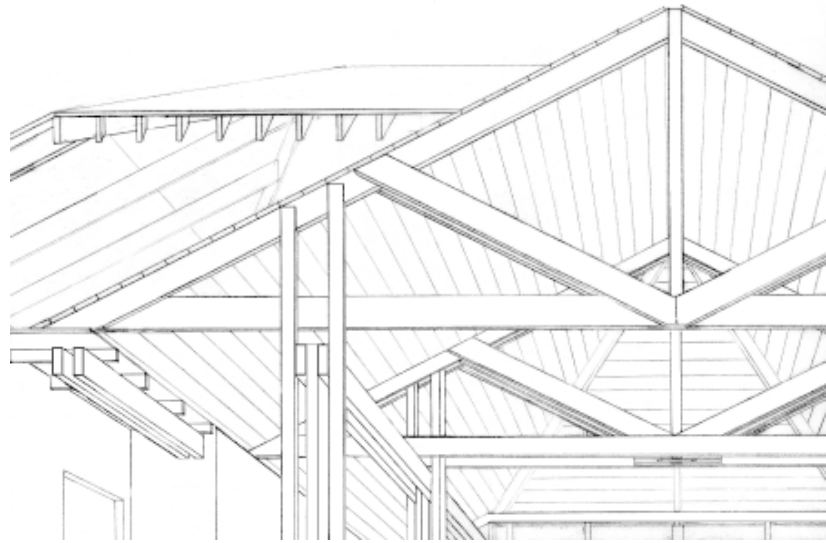

Roof

The roof truss allows the central room to expand vertically, thus enhancing the space. The trusses themselves are made of dimensioned lumber combined in the same structural vocabulary as the rest of the house.

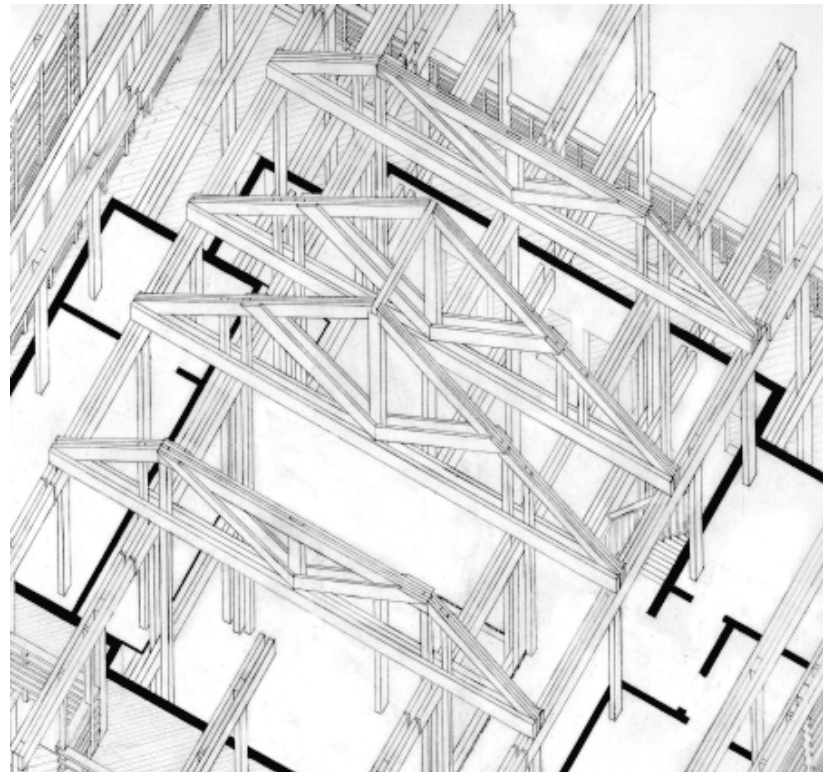

Plan

The plan regulates use of and movement through the space, and is greatly influenced by the structure. The structural column system removes the burden of bearing and allows the walls to function solely as partitions to provide visual and acoustical separation. The interplay of walls and columns enlivens the rooms and creates a logical grouping of circulation and living spaces.

“The plan is the generator. Without a plan, you have lack of order and wilfulness.”¹²

- Le Corbusier

Extension into the Landscape

Many architects have found that extending the building into the landscape creates a better connection between the structure and its surroundings. The architect can choose to expand into the surroundings either physically or by implication, and is often most successful with a combination of the two. Paths of circulation are especially well suited to this, and allow the house to blend with the landscape while simultaneously laying claim to the area as part of the domain of the house. This in turn allows blurs the distinction between inside and outside giving the house a feeling of greater size and grandeur.

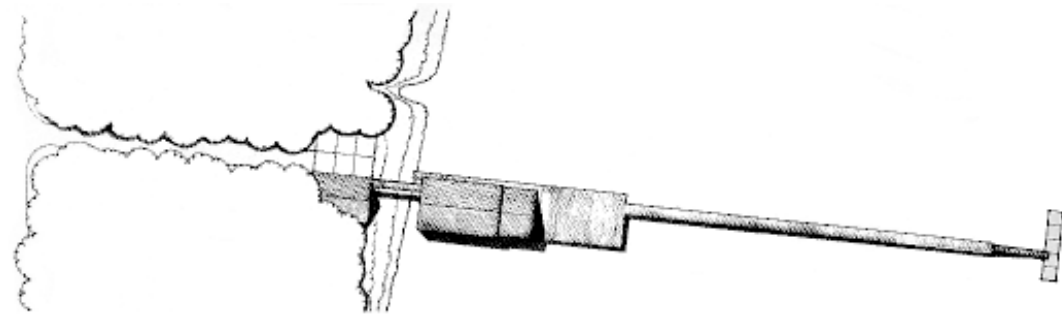

Parker Residence, Bainbridge Island, Washington, 1984 James Cutler.

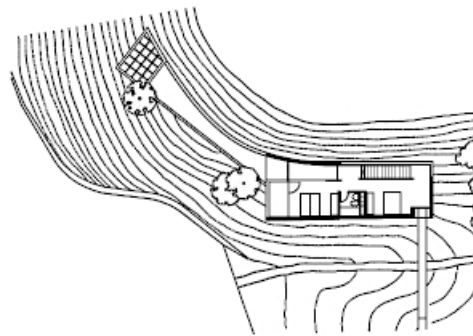

Kalman House in Minusio, Switzerland, 1975. Luigi Snozzi.

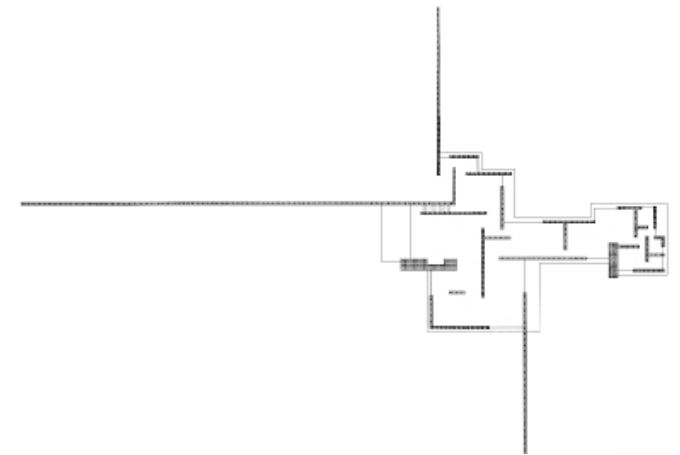

Brick country house, project, 1923 Ludwig Mies van der Rhoë.

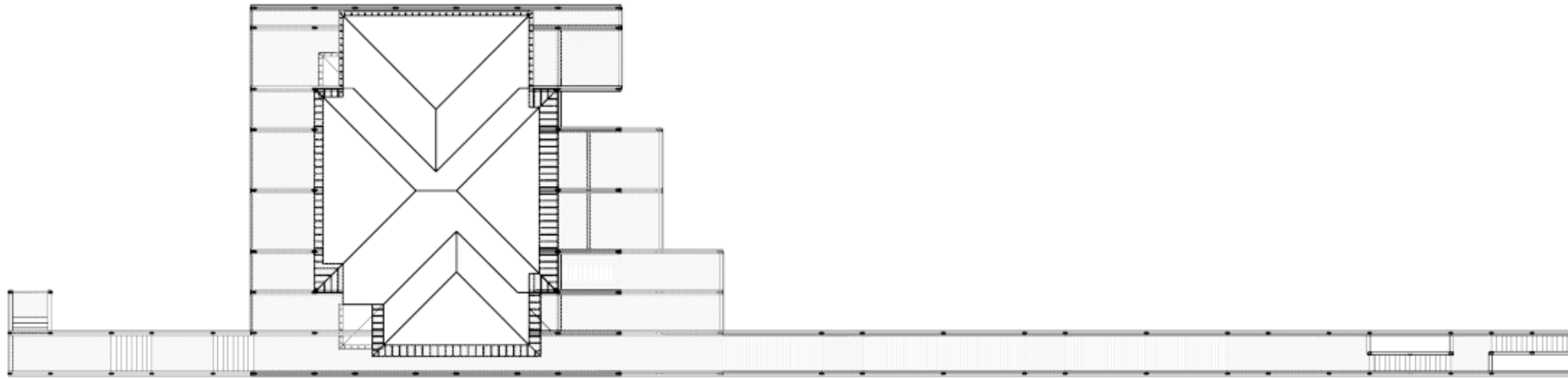

Ground Level

The ground level plays mainly a support role, as it can not be permanently inhabited due to the risk of flooding. The driveway is made of a permeable paver to allow maximum percolation of rain or storm surge while maintaining a safe driving surface. One wooden walkway connects the parking area to the front deck, while another travels under the house, past the two outdoor showers and connects directly to the rear deck and beach access. The two heat pump fans are also located under the house.

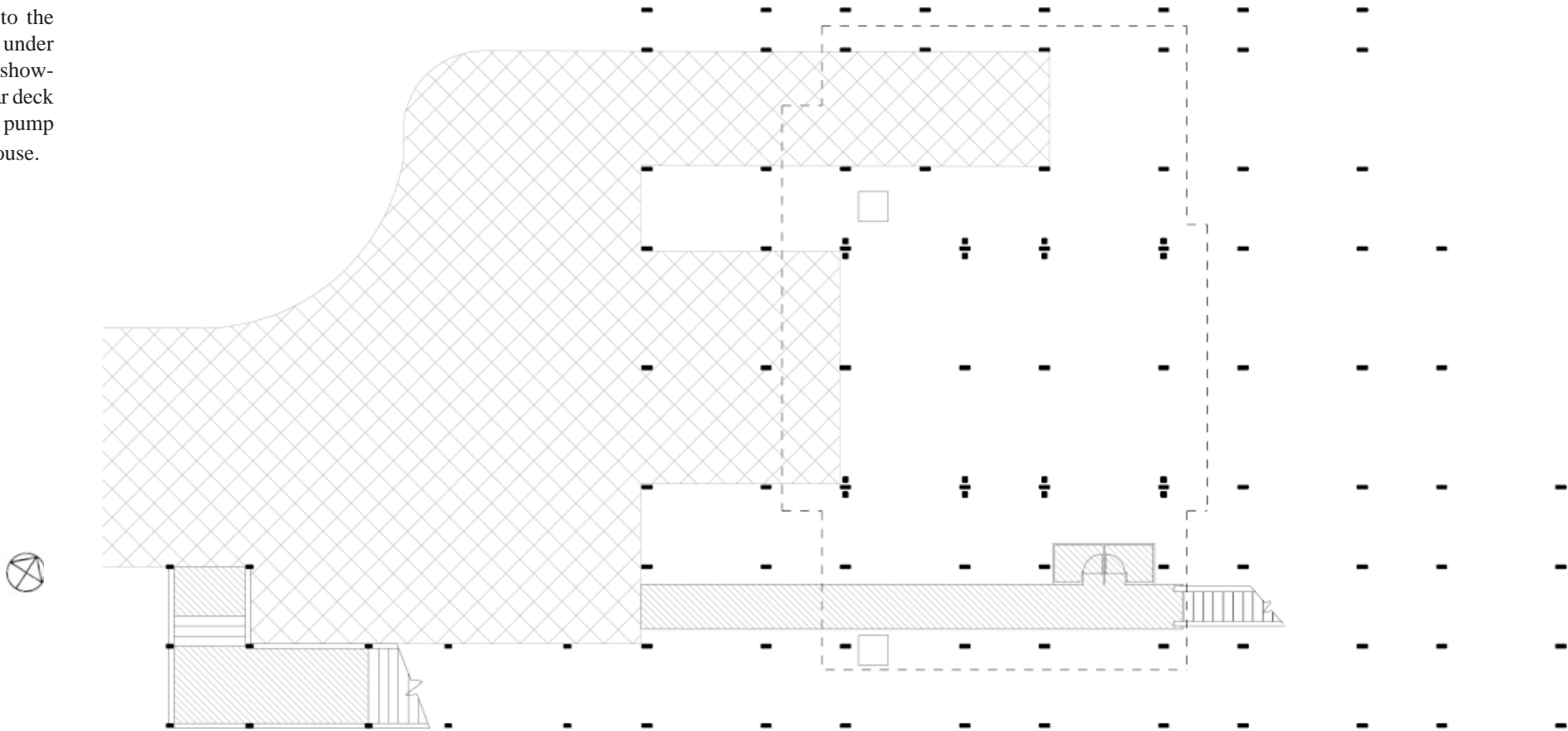

First Floor

The first floor is the heart of the house and is designed to contain all the rooms the owners will need when they are in the house by themselves. The main focus is the two story great room that serves as a connector between land and water. The ground surrounding the house is off limits due to environmental concerns, so the deck becomes a surrogate yard that is articulated to provide different levels of privacy and enclosure.

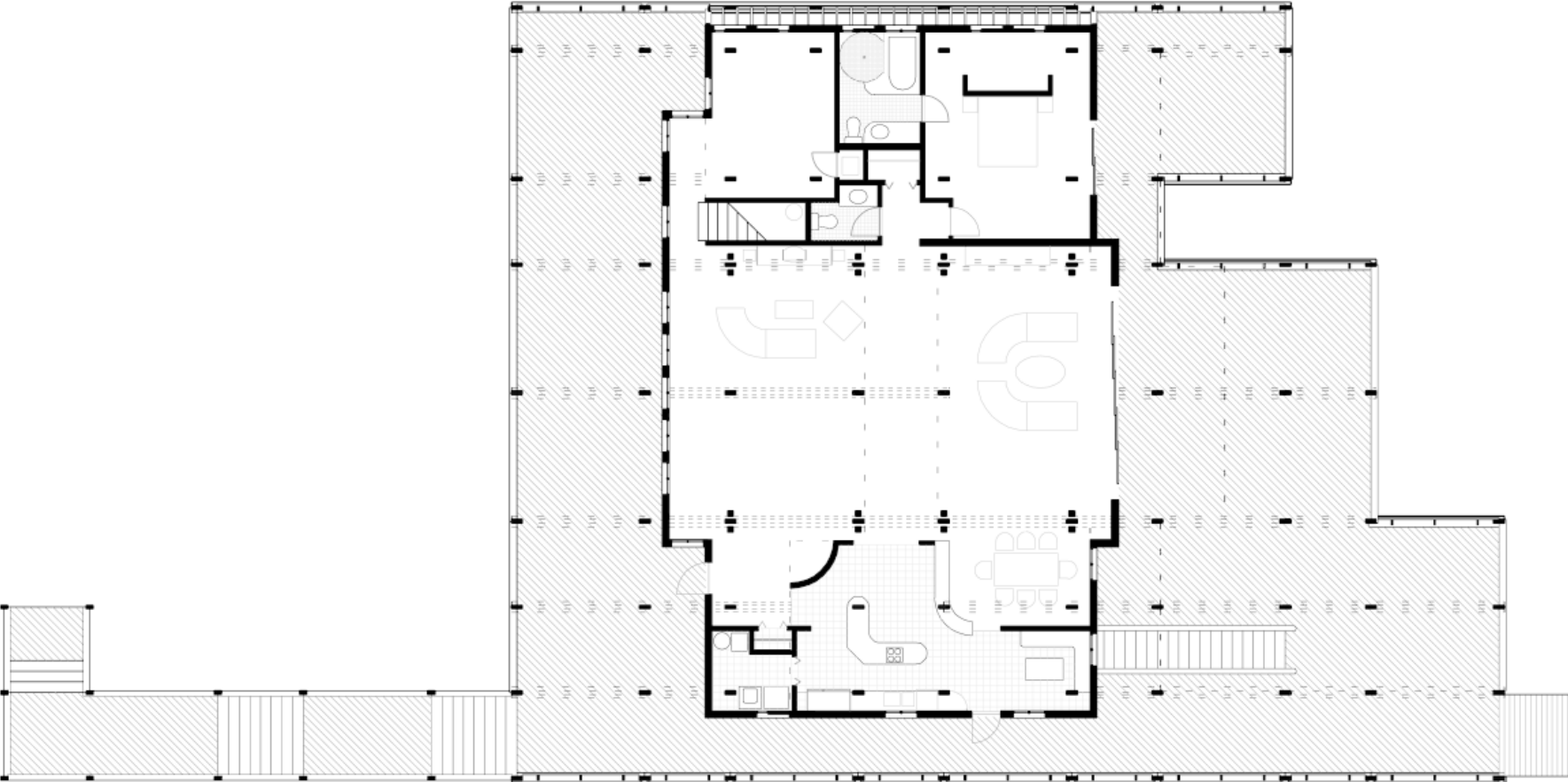

Second Floor

The entire second level is reserved for visiting family members and guests and consists entirely of bedrooms and bathrooms. The walkway through the center of the great room allows for circulation as well as a view of the ocean to the east and a glimpse of the Wright Brother's monument to the west. As with the first floor, walls are placed according to a 4 foot by 4 foot grid that is offset 2 feet from the structural grid.

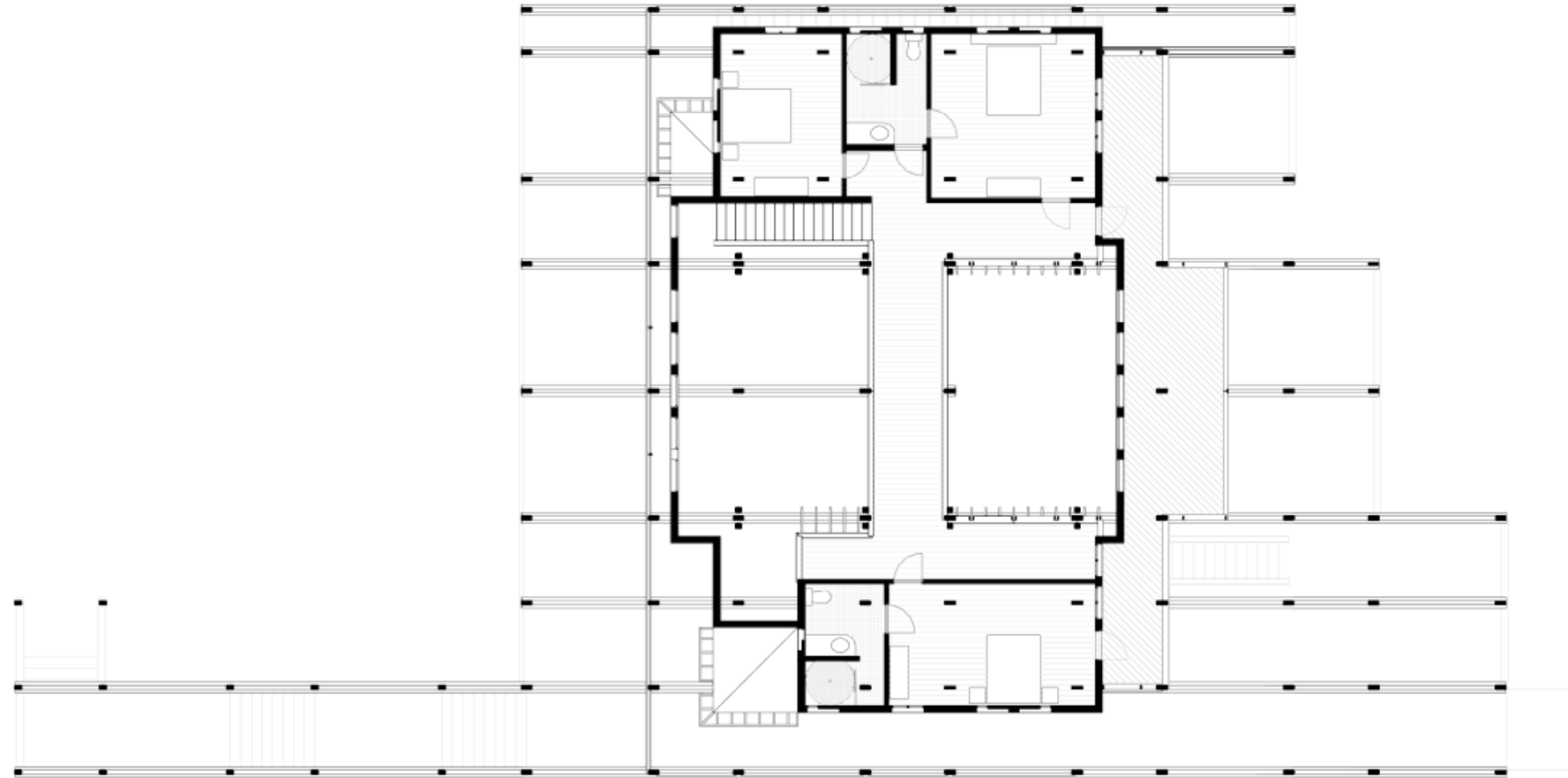

Roof Plan

The roof covers only the interior volume and exposes the joists wherever they extend beyond the building envelope. The lack of eaves minimizes the chance of roof uplift and the exposed joists provide additional sunshading and continue the concept of exposed structure. The central hipped roof increases the volume of the great room on the interior and expresses the importance of the space on the exterior.

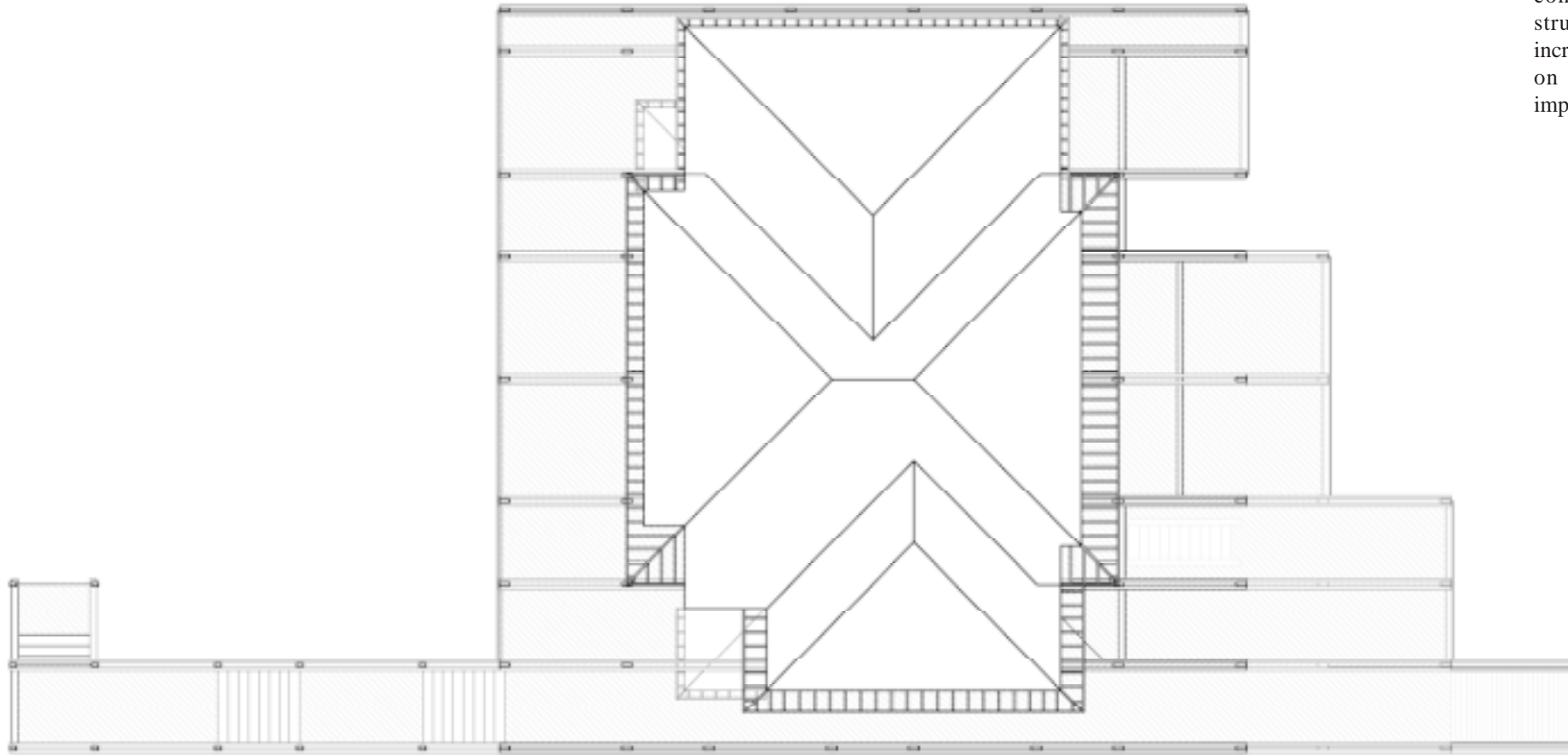

Envelope

The envelope provides separation between inside and outside, but also represents the face that the building shows to the world. In hurricane zones, a strong envelope is often the difference between the destruction or survival of the building, but the architect should not have to sacrifice the desired exterior aesthetic or interior outlook to create a safe structure. By considering all aspects of the envelope as integral parts of the design rather than necessary afterthoughts, the architect can create a building that is both functionally sound and aesthetically pleasing.

“I have endeavoured to establish a harmonious relationship between ground plan and elevation...considering one as a solution and the other as an expression.”¹³

- Frank Lloyd Wright

Shutters

Window protection is one of the most important needs for a house on the Outer Banks and has a profound effect on the exterior appearance of the building. Whatever type of protection is chosen, it must be strong enough to withstand high winds with associated airborne debris, opaque enough to defend against intense sunlight, and flexible enough to provide the greatest possible view. Wooden storm shutters are a traditional method of coastal window protection and perform double duty as sun shading during pleasant weather and wind protection during severe storms. They are inexpensive, easy to operate, permanently attached and provide an aesthetic unique to the hurricane belt. Some newer homes employ metal roll-down shutters that are less obtrusive, but their long-term performance is untested in the highly saline environment. Despite the fact that everyone realizes that they need window protection, some are still caught unprepared and must put the house through the ultimate indignity of nailed on plywood sheets each time a storm warning is issued.



The wooden storm shutters on this house are closed during the off-season to provide protection from both the elements and thieves.



Metal roll-up shutters operated from inside allow this second floor window to be quickly and easily protected.



These exposed bolts are ready to accept pre-cut pieces of plywood that can be quickly placed and secured without damaging the windows or trim.



Nailed on plywood sheets are dangerous to install, damage the building envelope, and often blow off to become wind-borne projectiles themselves.



New Jersey Beach House (1999) by Brian Healy and Michael Ryan. The gridded wooden louvers provide sunshading and privacy while maintaining the ocean view. They also function as window protection for the large expanses of glass in case of severe storms.

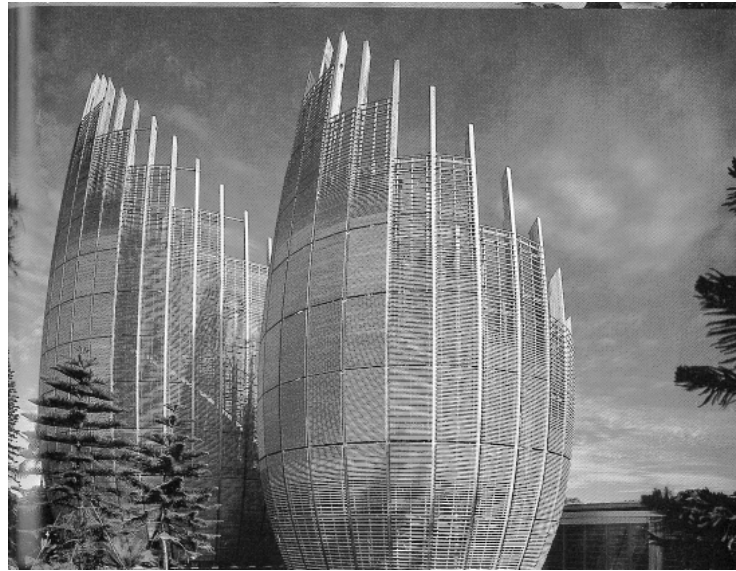

New Caledonia Cultural Center (1998) by Renzo Piano. The semi-circular *cases* shown here are a good example of a layered envelope that has an environmental purpose and also acts as the primary aesthetic statement. The exterior wooden ribs carry horizontal slats which help to mediate the often high winds of the site and also contribute to a passive ventilation system. The section to the right shows the several layers that occur between inside and outside.

Layered Envelope

The examples on the previous page use a distinct separation between inside and outside, but this does not have to be the case. By using several layers of envelope, the architect can create interesting “in-between” spaces that contain aspects of both the interior and exterior and provide a nice transition between the two. In addition to its aesthetic value, a complex envelope can also be used functionally for sunshading, privacy, wind protection and climate control

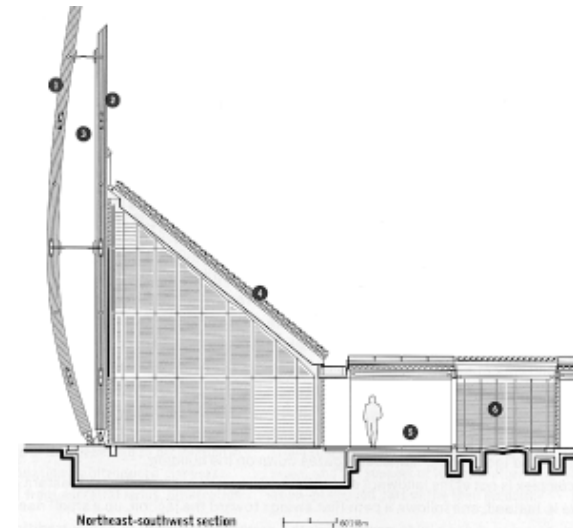

West Elevation

The west elevation faces the beach road and projects a rather formal tripartite appearance in keeping with its position as main entry facade. A wooden screen attached to the exterior columns continues the horizon line interrupted by the mass of the house while emphasizing the differentiation between the central and side masses. Functionally, the screen provides wind protection and sunshading for the large expanses of glass on the bright western side of the building.

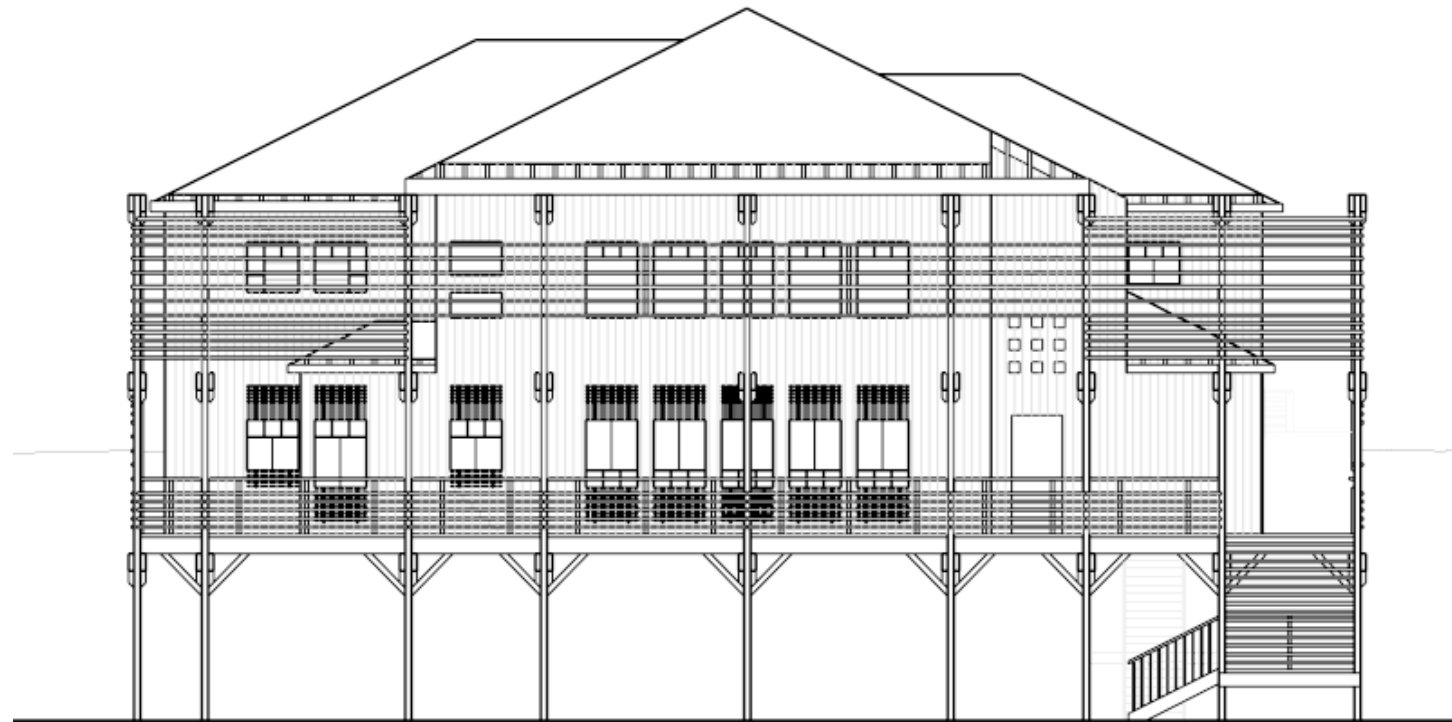

East Elevation

The east elevation faces the ocean and presents a more casual appearance without additional differentiation. The wooden screen is absent to allow for the greatest possible ocean views, and the railings maintain the horizontal emphasis provided by the screen on the other three sides. Wind protection is achieved using pre-cut plywood panels that mount to existing bolts in the window trim. The panels can be stored beneath the house and every window is accessible from the deck to make safe installation possible.



North Elevation

The north elevation has no need of sunshading, but instead uses the wooden screen for an additional layer of privacy for the bedrooms and bathrooms located on this side of the house. Since the bedroom in the northwest corner of the house does not connect to a deck, the wooden screen has a small gap near its window to allow for firefighter access in case of an emergency. The roof massing and exterior columns have a symmetry that is nicely contrasted by the offset cross-bracing below.

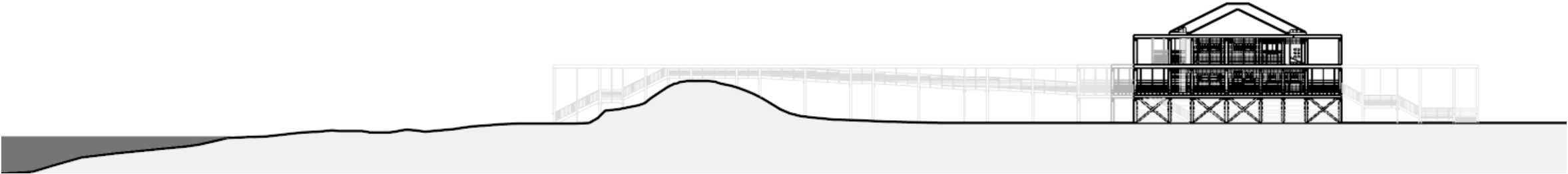
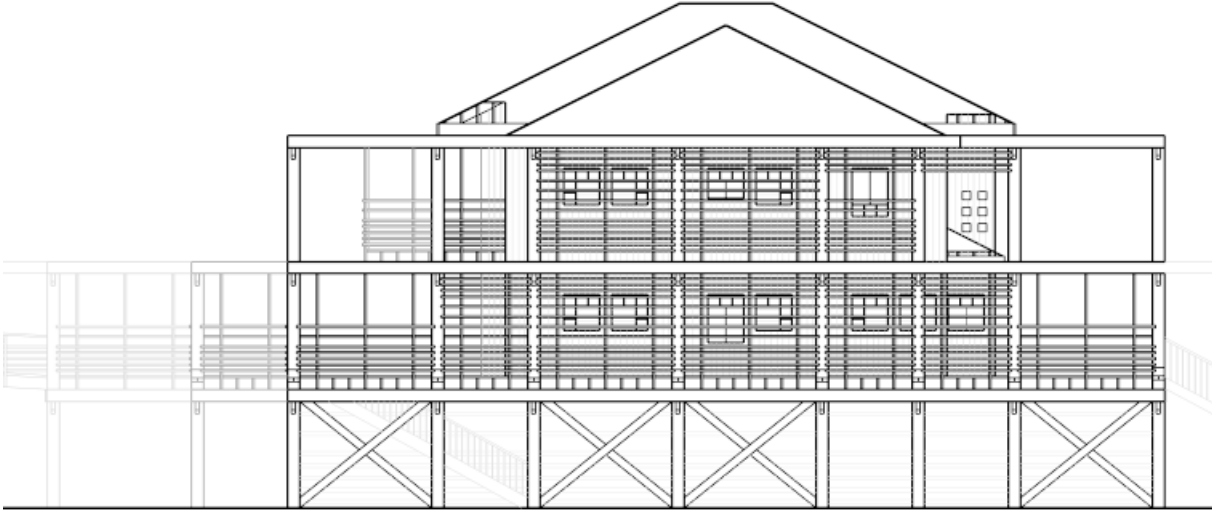

South Elevation

The south elevation is protected by two layers of exterior envelope because of the many conditions to which it must respond. Parking for the beach access abuts this facade, so the heavy wooden screen is in place mainly for issues of privacy, although it is also of value for wind protection and sunshading. The screen extends below the deck to reinforce the boundary between the public beach access and the private property of the house. Exterior shutters operated from the inside are the main source of sunshading, but offer additional wind protection and another layer of privacy. The walkway stretches from the entry to the beach delineating the domain of the house and creating a physical connection between land and water.



Findings:

Site response is perhaps the most difficult design decision because it varies from project to project. The architect must be completely familiar with the natural and man-made surroundings to design a building that can respond to and blend with the environment in which it exists.

The grid is a very helpful tool for the architect, but it is also very rigorous and must be handled with proper care. When choosing the grid type and module size it is important to consider room size, room layout, roof type, and building materials in order to avoid complications later on in the project.

Structure does not have to be regulated to a servant position, but can take an active part in the design of a building. Too often buildings are schematically designed in a vacuum and structure must be added with a resulting distillation of the original design intent. Structure should be considered as an architectural feature rather than a mechanical system.

Walls can be activated through interplay with other walls and exposed columns. This interaction can be used to enliven the rooms and help articulate the private and public spaces.

The expected use of the house should be the basis of the architectural solution to the program. The most aesthetically perfect house is of no use if it does not fulfill the owners needs.

Endnotes

- ¹ Orrin H. Pilkey, et. al., *Coastal Design*. (New York: Van Nostrand Reinhold Company, 1983) p. 16.
- ² Orrin H. Pilkey, et. al., *From Currituck to Calabash: Living with North Carolina's Barrier Islands*. (Durham: Duke University Press, 1980) p. 46.
- ³ David Stick, *The Outer Banks of North Carolina*. (Chapel Hill: University of North Carolina Press, 1958) p. 9.
- ⁴ H. Allen Brooks, ed. *Writings on Wright*. (Cambridge, MA: MIT Press, 1981) p. 164.
- ⁵ Richard C. MacCormack, "The Anatomy of Wright's Aesthetic," *Writings on Wright*. Ed. H. Allen Brooks (Cambridge, MA: MIT Press, 1981). p. 171.
- ⁶ H. Allen Brooks, ed. p. 40.
- ⁷ Richard C. MacCormack, p. 170.
- ⁸ Richard C. MacCormack, p. 172.
- ⁹ Tim Benton, *The Villas of Le Corbusier, 1920-1930*. (New Haven, CT: Yale University Press, 1987) pp. 200-201.
- ¹⁰ Global Architecture #13, *Le Corbusier, Villa Savoye, Poissy, France, 1929-31*. (Tokyo: A.D.A. Edita, 1972) p. 7.
- ¹¹ Global Architecture #13, p. 6.
- ¹² Le Corbusier, *Towards a New Architecture*. (1931; New York: Dover Publications, 1986) p. 45.
- ¹³ H. Allen Brooks, *Writings on Wright*. (Cambridge, MA: MIT Press, 1981). p. 40.

Image Credits

All images in this book were created, photographed or electronically manipulated by the author with the following exceptions:

Page 9: Hurricane Andrew images from *Assessment of Damage to Single-Family Homes Caused by Hurricanes Andrew and Iniki* by HUD.

Page 17: Palladio drawings from *The Four Books of Architecture*

Page 18: Wright grids adapted from *Writings on Wright* H. Allen Brooks, ed.

Page 19: Villa Stein plans adapted from *The Villas of Le Corbusier* by Tim Benton.

Page 20: Villa Savoye plans adapted from *Global Architecture #13*.

Page 24: Wright Guest House images from *Contemporary World Architects - James Cutler*.

Glasgow School of Art Library image from *Mackintosh's Masterwork: Charles Rennie Mackintosh and the Glasgow School of Art* by William Buchanan, et al.

Page 28: Collapsing house image from *Coastal Construction Manual* by FEMA.

Page 39: New Caledonia Cultural Center images from "Sea and Sky: Cultural Center, Noumea, New Caledonia." *Architectural Review*, December, 1998.

Works Consulted

- Buchanan, William, et. al. *Mackintosh's Masterwork: Charles Rennie Mackintosh and the Glasgow School of Art*. San Francisco: Chronicle Books, 1989.
- Benton, Tim. *The Villas of Le Corbusier, 1920-1930*. New Haven, CT: Yale University Press, 1987.
- Brooks, H. Allen. *Writings on Wright*. Cambridge, MA: MIT Press, 1981.
- Contemporary World Architects. *James Cutler*. Gloucester, MA: Rockport Publishers, 1997.
- FEMA. *Coastal Construction Manual*, 1986.
- FEMA. *Design Guidelines for Flood Damage Reduction*, 1981.
- Findley, L.R. "Piano Nobile: Renzo Piano's Jean-Marie Tjibaou Cultural Center." *Architecture*, October 1998: pp. 98-105.
- Gares, Paul A. *Coastal Dunes*. New Brunswick, NJ: Rutgers Center for Coastal and Environmental Studies, 1979.
- Global Architecture # 13. *Le Corbusier, Villa Savoye, Poissy, France. 1929-31*. Tokyo: A.D.A. Edita, 1972.
- HUD. *Assessment of Damage to Single-Family Homes Caused by Hurricanes Andrew and Iniki*. September, 1993.
- Ivy, Robert A, Jr. "Against the Tide." *Architecture*, May 1991: pp. 121-123.
- Le Corbusier. *Towards a New Architecture*. 1931. New York: Dover Publications, 1986.
- Le Corbusier. *Oeuvre Complete 1910-1929*. New York: Wittenborn and Company, 1964.
- Lizon, Peter. *Villa Tugendhat in Brno*. Knoxville, TN: University of Tennessee School of Architecture, 1997.
- Male, Emile. *Chartres*. New York: Harper & Row Publishers, 1983.

Mays, Vernon. "After Andrew." *Architecture*, April 1993: pp. 110-113.

McHarg, Ian L. *Design with Nature*. Garden City, NY: American Museum of Natural History, 1969.

McInstry, Sheila. "Sea and Sky: Cultural Center, Noumea, New Caledonia." *Architectural Review*, #1222, December 1998: pp. 30-37.

Moore, Charles, Gerald Allen and Donlyn Lyndon. *The Place of Houses..* New York: Holt, Rinehart and Winston, 1974.

Museum fur Gestaltung Zurich. *Luigi Snozzi - Auf den Spuren des Ortes Ein Gesprach in und um Monte Carasso*. Zurich: Museum fur Gestalt, 1996.

Palladio, Andrea. *The Four Books of Architecture*. 1570. New York: Dover Publications, 1965.

Pilkey, Orrin H. et al. *From Currituck to Calabash: Living with North Carolina's Barrier Islands*. Durham: Duke University Press, 1980.

Pilkey, Orrin H. et al. *Coastal Design*. New York: Van Nostrand Reinhold Company, 1983.

Rowe, Colin. *The Mathematics of the Ideal Villa and other Essays*. Cambridge, MA: MIT Press, 1976.

Ruffner, James A, and Frank E. Bair. *Climates of the States*. Detroit: Gale Research Company, 1987.

Ruffner, James A, and Frank E. Bair. *Weather of U.S. Cities*. Detroit: Gale Research Company, 1987.

Schulze, Franz. *Mies van der Rohe: Interior Spaces*. Chicago: The Arts Club of Chicago, 1982.

Stick, David. *The Outer Banks of North Carolina*. Chapel Hill: University of North Carolina Press, 1958.

Stick, David. *The Ash Wednesday Storm*. Kill Devil Hills, NC: Gresham Publishing, 1986.

U.S. Department of Commerce. *Hurricane Andrew: South Florida and Louisiana, August 23-26, 1992*. Natural Disaster Survey Report, November 1993.

Vonier, Thomas. "Blown Away." *Progressive Architecture* June 1993: pp. 124 - 127.

Vita:

Christopher S. Waltz

Education:

Virginia Polytechnic Institute and State University
Blacksburg, Virginia

Bachelor of Science in Civil Engineering, May 1992

Bachelor of Arts in History, June 1997

Travel program to Peru, January 1998

Travel program to Europe, May-July 1998

Master of Architecture, January 2000

Employment:

Shepley Bulfinch Richardson & Abbott

Boston, Massachusetts

August 1999 - present