

Esperanza— Village Building in Honduras

A self-build project



Esperanza— Village Building in Honduras

A self-build project

George Tehan

Thesis submitted to the faculty of the Virginia Polytechnic Institute and State University in partial fulfillment of the requirements for the degree of Master of Architecture.

May 22, 2006
Alexandria, VA

Committee Members:

Paul Emmons, Chair

Jaan Holt

Susan Piedmont-Palladino

Keywords: Honduras, Tegucigalpa, housing, village, poor, low income, self-build, passive cooling, courtyard, adobe

Copyright 2010

Abstract

There is a need to counteract economic injustice in the world. As an architect, as a creator, it is my responsibility to make the world a better place. I want to help people to help themselves by concentrating their efforts in a constructive way. I desire to create a prototypical solution for a village in an area with high unemployment and desperate poverty as a means to give work to people and to serve as an example for other groups of people wanting to do the same.

The site I've chosen to illustrate this concept of self-help housing is a 300 x 500 meter plateau in Tegucigalpa, Honduras.

Acknowledgements

Thank you,

to my wife, Sulema, for her support and understanding during my long hours in the studio,

to my mother, Madelyn, for always reminding me that I can be whatever I choose to be,

to my family for never giving up on me,

to Gladys for her humor and for the best food at any thesis defense,

to my family in Honduras, whose hope, strength, and joy of life is an inspiration to me,

to my friends, who are my 'chosen' family,

to my committee, Paul Emmons, Jaan Holt, and Susan Piedmont-Palladino, for pushing me to do more, and to do it better,

and to my father, George Edward Tehan, who always told me to choose a career that I love, because I would spend most of my life working at it. This book is dedicated to you, Dad.

Table of Contents

I.	Introduction	1
II.	Context	2
	A. Honduras	2
	B. Tegucigalpa	2
	1. Geography	2
	2. Population and Land Use	2
	3. Weather	2
	4. Needs	2
	5. Housing	2
III.	Client	6
IV.	Design	7
	A. Site	8
	B. Laws of the Indies	10
	C. Construction materials and methods	11
	1. Cinva-ram block press	11
	2. Brick quantity calculations	11
	3. Labor production and quantities	11
	4. Organization of work site	11
	D. A design for a village	12
	1. Orientation of Streets	14
	2. Views	14
	3. Plaza	14
	4. Housing	15
	5. Spirit and nature	15
	E. A design for a house	17
	F. A design for a plaza	19
	G. A design for a church	20
V.	Conclusion	30
VI.	Bibliography/credits	31
VII.	Appendix	32
VIII.	Vita	43

List of Figures/Images

ALL FIGURES AND IMAGES ARE BY THE AUTHOR, EXCEPT WHERE NOTED.

<u>Page</u>	<u>Illustration</u>
Cover	<i>Palm tree in Omoa, Honduras</i>
1.	<i>Slum in Tegucigalpa, Honduras</i>
3.	<i>Map of Honduras</i>
4.	<i>Various locations in Honduras</i>
5.	<i>Various locations in Tegucigalpa</i>
6.	<i>Tegucigalpa city dump, Honduras. The Micah Project, Tegucigalpa</i>
7.	<i>Dome interior of the National Cathedral, Washington, DC</i>
8.	<i>Maps of Tegucigalpa</i>
9.	<i>Map & views from building site</i>
10.	<i>Plan of San Antonio, Texas, ca. 1730. Author unknown</i>
11.	<i>Sketches of block-making process</i>
13.	<i>Site plan fold-out</i>
14.	<i>Site plans illustrating street grid and plaza</i>
15.	<i>Site plans illustrating housing and spirit</i>
16.	<i>Photos of site model</i>
17.	<i>Plan and elevation of typical house</i>
18.	<i>Housing cluster plan and photos of model</i>
19.	<i>Plaza plan, elevation, and photos of model</i>
20.	<i>Church keyplan</i>
21.	<i>Church plan fold-out</i>
22.	<i>Church elevation 1</i>
23.	<i>Church elevation 2</i>
24.	<i>Church elevation 3</i>
25.	<i>Church section A</i>
26.	<i>Church section B</i>
27.	<i>Church wall sections</i>
28.	<i>Church north wall interior elevation</i>
29.	<i>Church model photos</i>

I. Introduction

“We basically deal with wealthy people and we generally ignore the problems of most other people. One of the problems is that we don’t have a practice model that is able to deal with the true housing needs of the world’s population. It is ridiculous that we have 2 billion people living in slums. I think we are a profession that is not addressing our real public health obligations.” Thomas Fisher, Dean of the College of Architecture and Landscape Architecture at the University of Minnesota.

I fell in love with Honduras when I lived there for 5 months between August, 2004 and January 2005. Everything was different to me: the Spanish language, the friendlier and more relaxed ways people related to each other, *frijoles con tortillas and platanos*, constant music in the streets, simple houses made of concrete block or adobe with no indoor plumbing, the constant heat. But what stood out the most was the attitude of the people. Hondurans are fun-loving and hard-working with a sincere form of humor. It’s this humor and their willingness to laugh that made me feel welcome immediately.

A very short time after arriving in the country, I was aware of a chronic and pervasive poverty that struck me everywhere – in and around the capitol city of Tegucigalpa, on the sides of the hills next to the city dump, in the *platanos* groves - everywhere. In addition to this poverty was a rampant destruction of the environment, mostly in and around the large cities, but also in the countryside to a lesser extent. The fact that the majority of Hondurans cook over an open fire means that trees and shrubs, or *leña*, are in high demand. Many Hondurans “harvest” and sell *leña*, leaving the hillsides bare and prone to mudslides during heavy rains.

Seeing this combination of good people in desperate conditions gave me the inspiration for this thesis. My thesis is simply this: if the job of an architect is to promote and maintain the health, safety, and welfare of the public through good design, how can I use my knowledge and skill to combat abject poverty through rationally designed, environmentally sustainable architecture? In this thesis, I propose one possible solution.



Slum in Tegucigalpa, Honduras

II. Context

A. Honduras

Although this thesis is not an historical one, it is important to consider the historical, natural, and built context of a place when designing architecture.

Honduras is a beautiful, mountainous country. It is a small country, about the size of Pennsylvania. It's history is rich, beginning with the Mayans, Nahuatl, and Pech indigenous peoples. The most advanced of these people were the Maya, who built an important city named Copan in the western part of Honduras which flourished until the 9th Century and had 20,000 residents. Christopher Columbus landed in Honduras in 1502 to begin the Spanish Conquest. Spain ruled Honduras until September 15, 1821, leaving behind over 300 years of influence in all aspects of society, absorbing and mixing with the native populations until very few traces of them remained. The Spanish influence is important in the architectural development of Honduras, especially in development of towns and cities due to the ordinances contained in the Laws of the Indies, which will be explored further in the design portion of this study.

Today, Honduras has a population of about 7 million people. About 40% of Hondurans (2.7 million) live in "extreme" poverty, surviving on less than \$1 per day. About 79% of Hondurans live below the poverty rate, defined as earning less than \$167/month. The average income in Honduras is \$970/year.

B. Tegucigalpa

When one arrives in the capital city, Tegucigalpa, the first impression is one of complete chaos. There are people everywhere – on the sidewalks, in the streets, everywhere. Add to this the taxis, who honk habitually with their own distinct whistle-like sounds, the stand-still traffic in the old Spanish colonial streets, the street booths selling mangos & peeled oranges in clear plastic bags, the street vendors pushing wheel barrels full of *mamones* (a sweet, grape-sized tropical fruit) on the already too-crowded sidewalks, the beggars begging for 1 *lempira* (about 5 cents). It's this wonderful chaos that gives the city its unique flavor. It can be a dizzying place, a potentially dangerous place, but never a boring place. It is a city of modern hotels, high-rise office buildings, a 400 year-old cathedral, and a Spanish colonial governmental palace of the same age.

1. Geography

Tegucigalpa is located in a valley of the same name at an elevation of 3,250 feet. The name is derived from the Amerindian "Tekut Xiuatl Pan" meaning 'Silver Mountain'.

2. Population and Land Use

Tegucigalpa is expected to double in population, and most likely double in area before 2029. The population will reach 2,000,000 people in an area of 180 square kilometers. In 2000, roughly 640 hectares of the urban area were identified as high-risk due to landslides.

3. Weather

Average monthly temperatures in Tegucigalpa range from 30° C (86° F) in April, the hottest month, to 25° C (77° F) in January, the coldest month. By contrast, Washington, D.C.'s averages range from 26° C (78° F) in July to 1° C (33° F) in January.

The rainy season in Tegucigalpa is from May to October, with an average of 650 mm (25") per month. In the dry season, the rainfall can be as little as 18 mm (3/4") per month.

4. Needs

The three most urgent needs in Tegucigalpa are: water, sanitation, and transportation.

Taxis are the main way to get around in Tegucigalpa, as the city does not have an extensive rapid-transit system.

5. Housing

Over the past 25 years, the urban area of Tegucigalpa has tripled in size. In Tegucigalpa, like many cities of the developing world, informal development dominates formal development. Illegal land invasions house more than 60% of the total population. 3% of the population in Tegucigalpa owns 40% of the land. 60% of the land does not have a clear title. Land occupied for 10 years legally becomes the property of the "invader", regardless of a prior legal title. Approximately 9,000 houses are constructed in Tegucigalpa every year with only one-third constructed in the formal sector. Approximately 125,000 residences have been built illegally in Tegucigalpa. Many are very well built.



It is difficult to describe a place in words alone. Following are photographs that are keyed to the map below and aid in the description of place.



A. Amapala Island



B. Boat to Amapala Island



C. Amapala Island



D. Spanish colonial church of San Lorenzo



E. Central plaza of Pespire



F. Pespire



G. Spanish colonial church of Cedros



H. Fortaleza de San Fernando de Omoa



I. Crossing Talgua River



J. Talgua—Burro carrying leña



K. Catacamas



L. Catacamas



M. Tegucigalpa detail



P. Tegucigalpa



Q. Tegucigalpa panorama



N. Tegucigalpa



O. Tegucigalpa



R. Tegucigalpa panorama

III. Client

Los Ovlidados

Honduras is swelling with underprivileged, under-utilized people. This thesis proposes a solution to house approximately 1200 people in a village using their own skills to create their dwellings, businesses, public buildings, and a church.

There are currently about 1200 people living in the Tegucigalpa city dump, of which about 300 are children. These are the *ovlidados* or the “forgotten” of the poorest of the poor. These people live in shacks made of sticks and plastic, which they salvage from the dump. There is no shortage of poor in Honduras, where 40% of people live on less than \$1/day, but the people of the city dump are a particularly sad example of the hell that is extreme poverty. That is not to say that they are not productive or hard working. Everyday, they gather around the dump trucks to scavenge the waste produced by the better-off residents of the city. They scrounge for rags, clothes, and food. They also gather plastic bags and bottles for recycling for which they are paid \$1/day. At the end of the day, they go to their shacks to eat what they have scavenged and to cook the little bit of rice and beans that they have been able to purchase. They may not be starving to death, but their existence is marginal and comes with a whole host of problems: disease and early death due to lack of health care, illiteracy, dangerous living conditions, and lack of opportunity. When one sees this with their own eyes, one cannot help to question why. One cannot help to want to try to change these circumstances and help.

The work that they do is hard and dangerous, but for these people, there is no other option. It is the end of the road in an already impoverished country. Perhaps their work can be redirected in a more efficient way that can have a more constructive outcome—a lasting change.

All photos this page: *Tegucigalpa city dump, Honduras.*
The Micah Project, Tegucigalpa.



IV. Design



A. Site

The site is on a plateau with exposure to mountains on all sides and every view is naturally beautiful. However, there are two significant views from the site which determined the principal E-W axis of the village: the view east toward Tincontin Airport and the view west toward Los Laureles Dam.

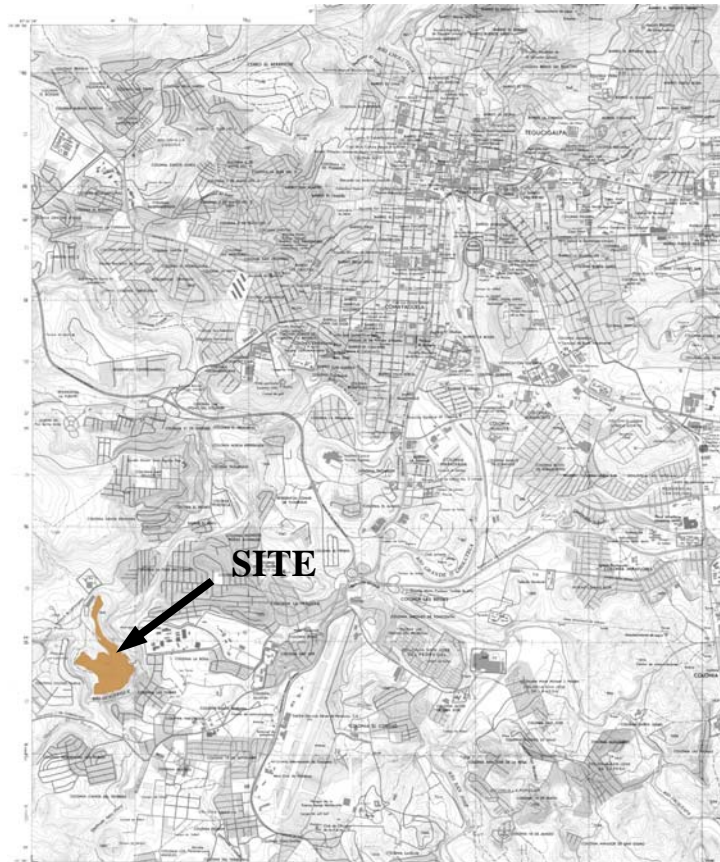

TEGUCIGALPA MAP

METERS
0 1000 2000



N
METERS
0 100 200 300 400



View 1 North from Colonia Las Torres



View 2 West from site to Los Laureles Dam



View 3 Northwest from Colonia Las Torres

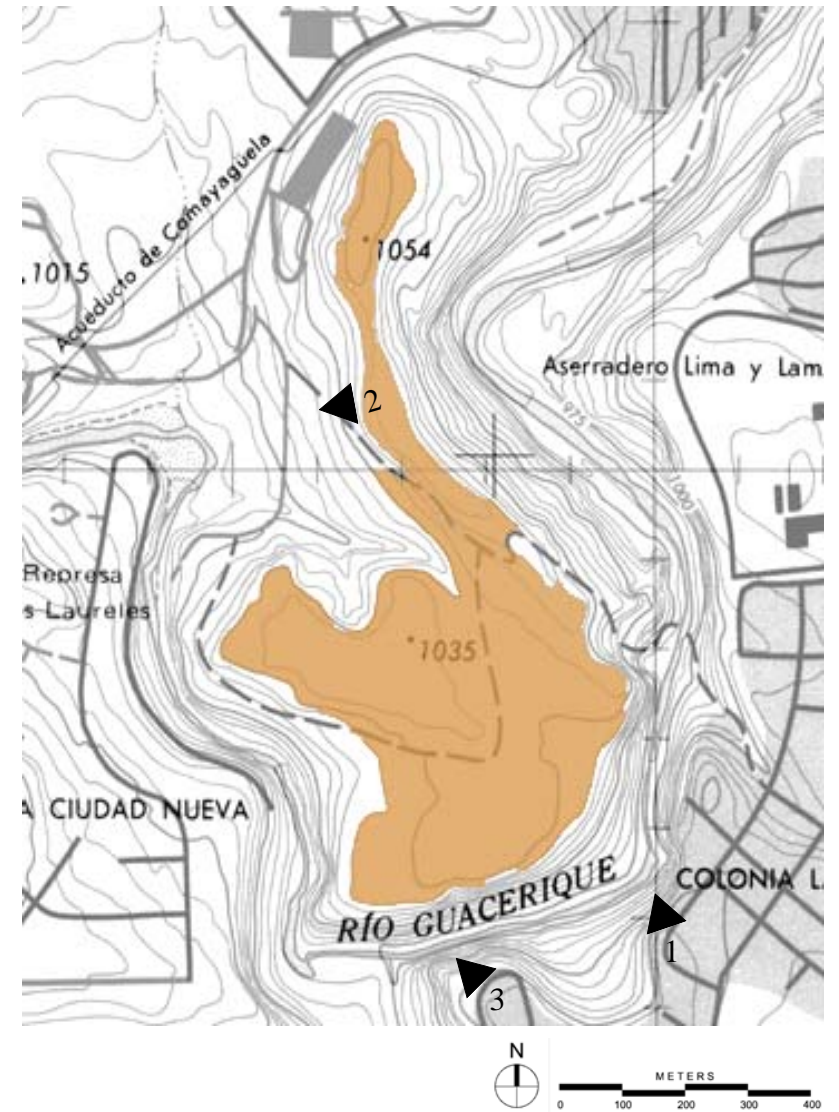

B. Laws of the Indies

An architect should design with the context in mind. The architect can choose to deviate from the context if he finds the context objectionable or unsatisfactory, or the architect can design in accordance with the context. I chose to do both. I rejected the current context of environmental degradation and haphazard development in favor of a return to the context of the original Spanish colonial settlements. When the Spaniards first came to Central America they brought with them instructions on how to develop their towns. The Laws of the Indies, also known as the Ordinances for the Discovery, the Population and the Pacification of the Indies, were decreed by King Phillip II in 1573 and provided the foundation for many of the cities throughout Latin America. The following ordinances pertained to the planning of towns (the preceding number is the ordinance number):

- 35. And they should be in fertile areas with an abundance of fruits and fields, of good land to plant and harvest, of grasslands to grow livestock, of mountains and forests for wood and building materials for homes and edifices, and of good and plentiful water supply for drinking and irrigation.
- 39. The site and position of the towns should be selected in places where water is nearby...and, [these sites and positions should be suitable] also for farming, cultivation, and pasturing, so as to avoid excessive work and cost, since any of the above would be costly if they were far.
- 40. Do not select sites that are too high up because these are affected by winds, and access and service to these are difficult, nor in lowlands, which tend to be unhealthy; choose places of medium elevation that enjoy good winds, especially from the north and south, and if there were mountains or hills, these should be in the west or in the east, and if there should be a need to build in high places, do it in areas not subjected to fogs; take note of the terrain and its accidental features and in case that there should be a need to build on the banks of a river, it should be on the eastern bank, so when the sun rises it strikes the town first, then the water.
- 112. The main plaza is to be the starting point for the town...inland it should be at the center of the town. The plaza should be square or rectangular...for any

other fiestas that should be held.

- 113. [The Plaza] shall be not less that two hundred feet wide and three hundred feet long, nor larger than eight hundred feet long and five hundred and thirty feet wide. A good proportion is six hundred feet long and four hundred wide.
- 114. From the plaza shall begin four principal street: One [shall be] from the middle of each side, and two streets from each corner of the plaza...
- 116. In cold places, the streets shall be wide and in hot places narrow...
- 122. The site and building lots for slaughter houses, fisheries, tanneries, and other business which produce filth shall be so placed that the filth can easily be disposed of.
- 124. The temple in inland places shall not be placed on the square but at a distance and shall be separated from any other nearby building, or from adjoining buildings, and ought to be seen from all sides so that it can be decorated better, thus acquiring more authority; efforts should be made that it be somewhat raised from ground level in order that it be approached by steps...
- 126. In the plaza, no lots shall be assigned to private individuals; instead, they shall be used for the buildings of the church and royal houses and for city use, but shops and houses for the merchants should be built first...
- 127. The other building lots shall be distributed by lottery to the settlers, continuing with the lots closer to the main plaza...
- 134. They shall try as far as possible to have the buildings all of one type for the sake of the beauty of the town.
- 135. [The] architects...shall hurry in their labor and building so that the town may be completed in a short time.

For the plan for Esperanza, I adopted many of the principles of the Laws of the Indies in addition to the following design philosophy.

New Urbanism

These principles are also experiencing a revival in the United States in a movement known as New Urbanism, which is a reaction against post-World War II urban sprawl. New Urbanists have been criticized for yearning for a more romantic, innocent time, which no longer exists.

However, the New Urbanist tenets can be applied without resulting in quaint, picket-fence type developments. Some of the basic tenets are as follows:

- The town has a square, with a transit stops to connect to other towns.
- The buildings in the square are substantial, creating a well-defined space.
- There are civic buildings in the center or at important street terminations, which serve an additional functions such as community and cultural centers.
- Houses are within walking distance of the square.
- There are a variety of housing types, i.e. houses and apartments, so that the population can mix regardless of income levels. In other words, everyone is able to find a place to live nearby.
- Primary and secondary schools are within walking distance of houses.
- Green spaces are plentiful and within walking distance of houses.
- Streets are oriented so that there are many options for getting from one place to another.
- Streets are tree-lined and narrow, slowing traffic and creating a walkable neighborhood.

PLANO DE LA POBLACION.



Plan of San Antonio, Texas, ca. 1730.

C. Construction materials and methods

Reinforced concrete is the material of choice for the foundations, columns, and beams of the prototypical Esperanza house.

1. Cinva-ram block press

The machine used to make compressed adobe blocks is called a CINVA-ram machine, developed by the Raul Ramirez of the Inter-American Housing Center (CINVA). It is a low-cost, easily transported machine that compresses a mixture of soil and cement into blocks that need no baking. To run at full production, a team of 8 workers is required per machine, with two of the workers operating the machine and the other six preparing the mixture and stacking the blocks. At this rate, one machine can produce an average of 300-500 blocks per day at the building site.

The steps involved are as follows:

1. Choose and prepare the earth to be used
2. Screen the earth through a ¼" x ¼" wire mesh
3. Add 5-10% cement to the mixture
4. Sprinkle water over the dry mixture to add moisture content
5. Load the mixture into the mold box
6. Compress the mixture
7. Eject the block from the press
8. Stack the block for curing 10 days

2. Brick quantity calculations

Following is a calculation of the number of bricks needed in a double-wythe 3m x 3m wall:

The basic brick size is 9cm x 14cm x 29 cm.

The exterior wall thickness is 29cm.

A mortar joint is 2cm.

The area of a 3m x 3m wall is 9 sq. m.

The area of the brick face with mortar joint is .0319 sq. m.

The number bricks required for one side of the wall is 282.

For a double wythe wall, the number of bricks required is 564.

3. Labor production and quantities

The basic steps involved in laying the bricks are as follows:

- Mortar mixing
- Mortar delivery to wall
- Brick delivery to wall
- Brick setting
- Striking and cleaning of excess mortar from joints

A team of masons consists of a mason, a mason tender, and a helper. A team of this size is able to lay 400-800 bricks/day at shoulder height, or 200-400 bricks/day on scaffolding. Therefore, a team of three will be able to build a 3m x 3m double wythe wall in about 1-1/2 days.

4. Organization of work site

It is important for maximum efficiency to organize the work site so that the bricklayer does not have to go far for bricks and mortar. It is practical to have 3-4 mud/mortar mixing pits on the site so that the mason tender can efficiently and quickly bring mortar to the bricklayer. Also, when the bricks are brought to the site, it is advisable to stack the bricks near the wall that they will make.

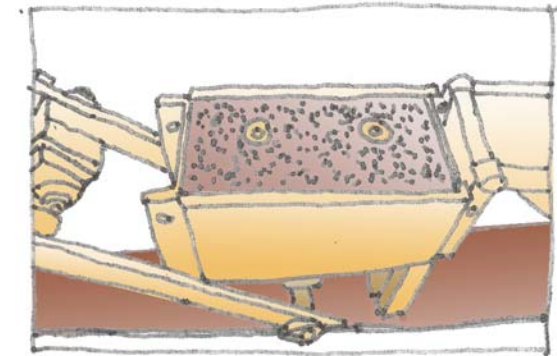

MIXTURE LOADED INTO PRESS

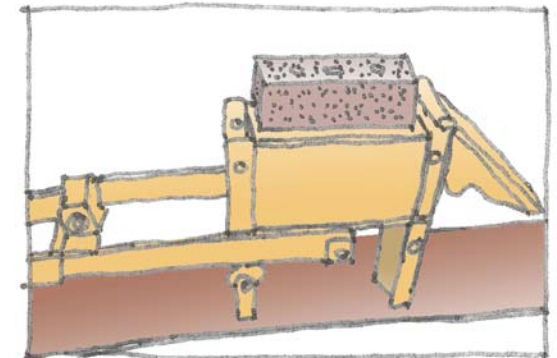

BLOCK EJECTED AFTER PRESSING

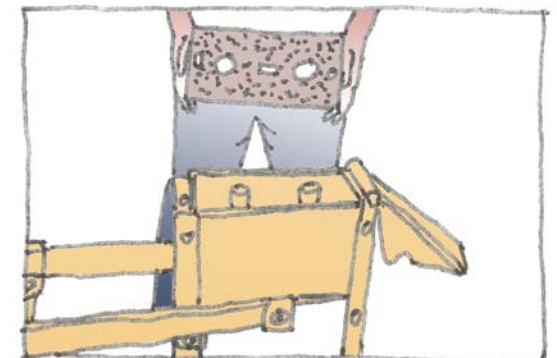

BLOCK EXTRACTED FROM PRESS

D. A design for a village

Esperanza, a village for 1200 people, is meant to be essentially self-sufficient. This means that there has to be more in the village than just a collection of houses. For a village to be viable, there has to be a commercial center, mixed densities in housing, and opportunities for recreation and spirituality.

Borrowing from the Laws of the Indies and New Urbanist principles, Esperanza was designed with the following features:

- The square was laid out in the center of the plateau so that it would not be too far from any one house.
 - The largest buildings in the town (2-3 stories), define the square with an almost continuous arcade on the perimeter.
 - There are two main streets, which intersect at the square and divide the town into 4 sections.
 - Civic and market/retail buildings are reserved for the center.
 - The densest part of the plan is at the entry to the town, where there are apartment buildings before reaching the square.
 - The religious center is on the highest part of the site, where it can be seen from all sides and far enough from the center to stage religious processions and funerals.
 - The soccer field is apart from the town, but close enough for everyone in the town to reach on foot.
 - There are smaller and larger parks, some with views out from the site to the neighboring mountains.
 - There are palm trees and banana trees on the outside “ring” road, along the main axis roads, and in the town square as a response to the environmental degradation and lack of green space in Tegucigalpa. Also, the courtyard of every home has a mango tree, which is the common practice today. The trees serve two roles: they provide shade and bear fruit.
- The village is essentially a series of courtyards. There are small courtyards at the house level, larger “courtyards” at the intersection of streets (due to the narrowness of the streets and alleys), even larger courtyards that are parks, then the largest courtyard, which is the plaza. This form serves to provide shade for the houses from the harsh sun throughout the day and space for people to interact.



- CHURCH
- COMMERCIAL
- HOUSES
- APARTMENTS
- PARKS

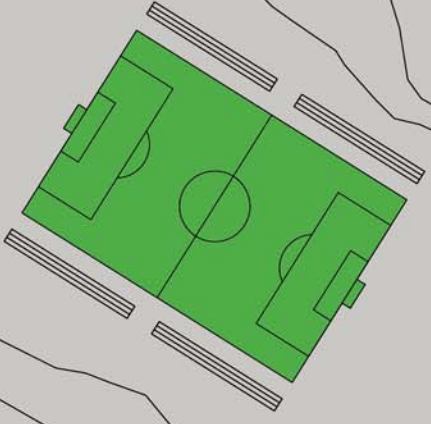



1. Orientation of streets

Because of the climatic conditions at the site, only cooling is a concern. In this area, the number of days when heating is needed is minimal. At the scale of the village, orientation of the streets is fundamentally important. If the streets are oriented in such a way that the sun strikes and heats them all day, the houses along these super-heated streets will be very uncomfortable as the wind carries this heat inside. Therefore, it is important to minimize the number of hours that the sun strikes directly on the streets. A series of computer experiments determined that the ideal orientation of streets for this site is a 45° grid. Also, to maximize shading, a pattern of narrow streets is ideal. The streets range in width from 3 meters for alleys to 7 meters for boulevards at the village center.

2. Views

Although a 45° grid is ideal, this was compromised a bit to take advantage of some of the more dramatic views out from the site. There are two significant views from the site which determined the principal E-W axis: the view southeast toward Tintocin Airport and the view northwest toward Los Laureles Dam. These axes terminate in small parks with a views toward these places. The other principal axis was simply 90° from the E-W axis.

3. Plaza

The commercial center with its central green is the economic and social “heart” of the community. This section of the village is very active, as during the day, a majority of the residents work here or buy goods. At night, the plaza is a place to “see and be seen”, perhaps listen to music, or dine in small restaurants that are nestled within the arcade.

Street Grid

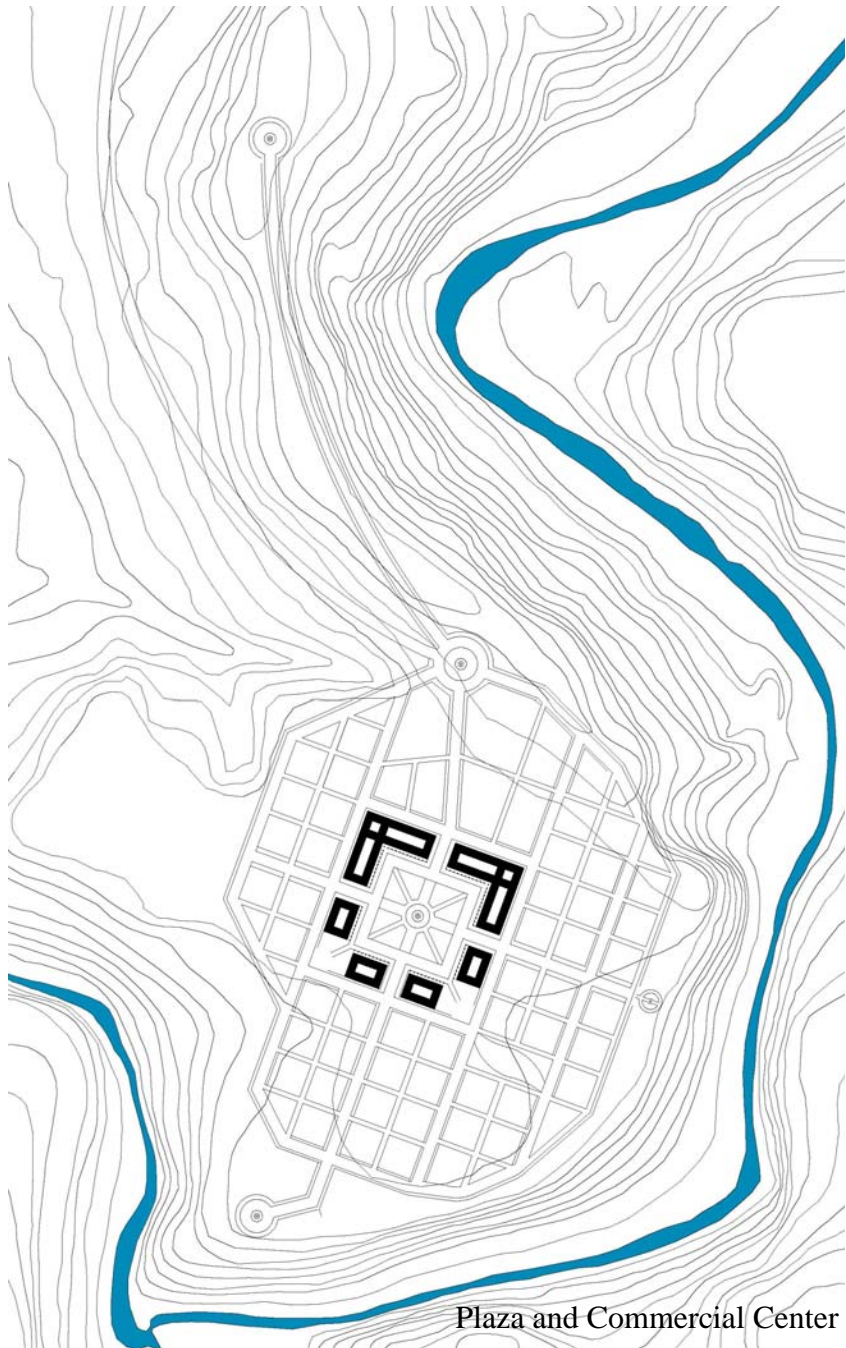

Plaza and Commercial Center



4. Housing

Density in housing is integral to the rhythm of the village. Variation in density creates variation in “personality” of different parts of the village. The larger apartment blocks in the north-central part of the village are livelier than the quieter part of the village closer to the church at the extreme north end. This enables people to have a choice to be in quieter, more solitary areas—or in livelier, more active areas. Additionally, the apartment buildings are an income generator, as they would be owned by the residents of the village and rented to younger, more affluent residents of Tegucigalpa who need economical housing near the city.

5. The spirit and nature

The church, with its procession away from the economic center to the top of the hill is the spiritual “head” of the village. This procession is connected by a “green” network of banana and coconut palms that shade every major street in the village. In addition, the trees provide food and income to the residents. Villagers can enjoy the natural beauty of the surrounding mountains by walking along the outside of the village under the palms, stopping by one of the small parks at the axis termini, or playing soccer in the large field.



View looking North



View looking South

E. A design for a house

The principal design concerns for the basic house unit are passive cooling using shade and ventilation. The main reason for using a passive system is that such a system relies upon and takes advantage of the conditions of the site. It is not a forced, ecologically and financially expensive solution, as is air conditioning in the industrialized nations. The house form is based on the need for shade and protection from the sun. The inwardly-focused courtyard form is ideal for this climate and is traditionally used throughout Latin America, the Middle East, and Africa. Also traditional in Latin America is a large mango tree in the center of the courtyard. This also provides shade, in addition to sweet fruit in March. In addition to the courtyard, the house has a porch with a deep roof overhang. The shade “pre-cools” the air before it comes into the house through low openings on the courtyard side. On the street side, the window openings are high, which creates a draft, drawing cool air from the courtyard through the house, then out of the high street-side openings.

As is common practice, and to reduce heat gain inside the house, the stove is outside in the middle of the shared wall between houses. A stove type dubbed *Estufa Justa* (see Appendix) provides a safer and more efficient form of cooking, which carries smoke away from the cook and uses less wood, therefore fewer trees are cut down.

The prototypical house type in Esperanza is a concrete rigid-frame structure with compressed earth brick infill. The concrete rigid-frame is a common construction type in Honduras, but may not be necessary if cost prohibits construction of this type in desperate areas. A single concrete bond beam at the top of the wall may be adequate to tie the structure together, depending on wall height, seismic zone, etc. This change in structure would need to be evaluated in depth at the site.

A type of composting toilet called *Clivus Minimus* (see Appendix) is located on one end of the house. This eliminates the need for expensive waste piping and a village sewage system.

Housing will be built as “Phase I” to satisfy immediate shelter needs.

- 1 DINING ROOM
- 2 LIVING ROOM
- 3 KITCHEN
- 4 BEDROOM
- 5 BEDROOM
- 6 BEDROOM
- 7 TOILET
- 8 PORCH
- 9 STOVE
- 10 MANGO TREE
- 11 LAUNDRY/DISHWASHING

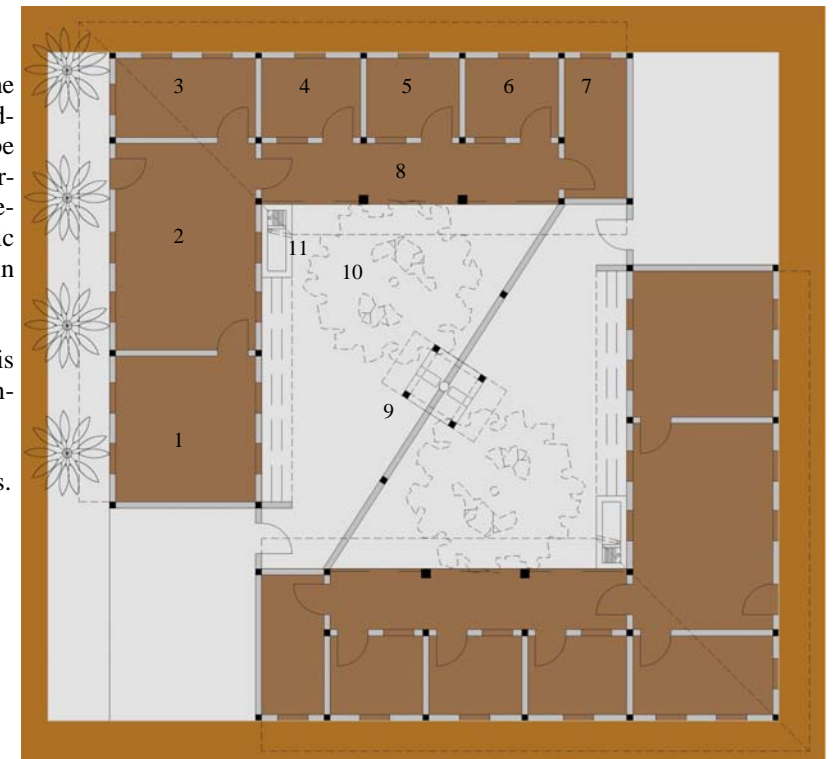

TYPICAL HOUSE PLAN

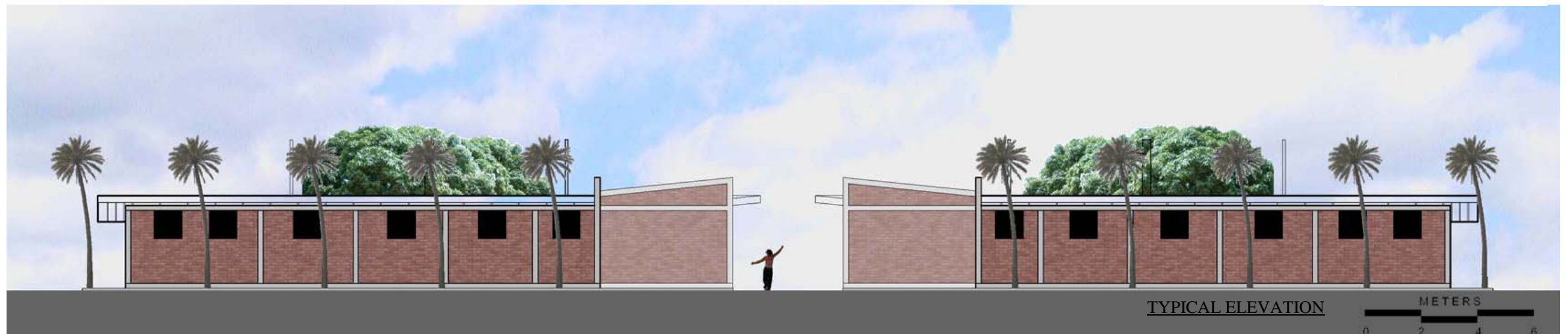

TYPICAL ELEVATION



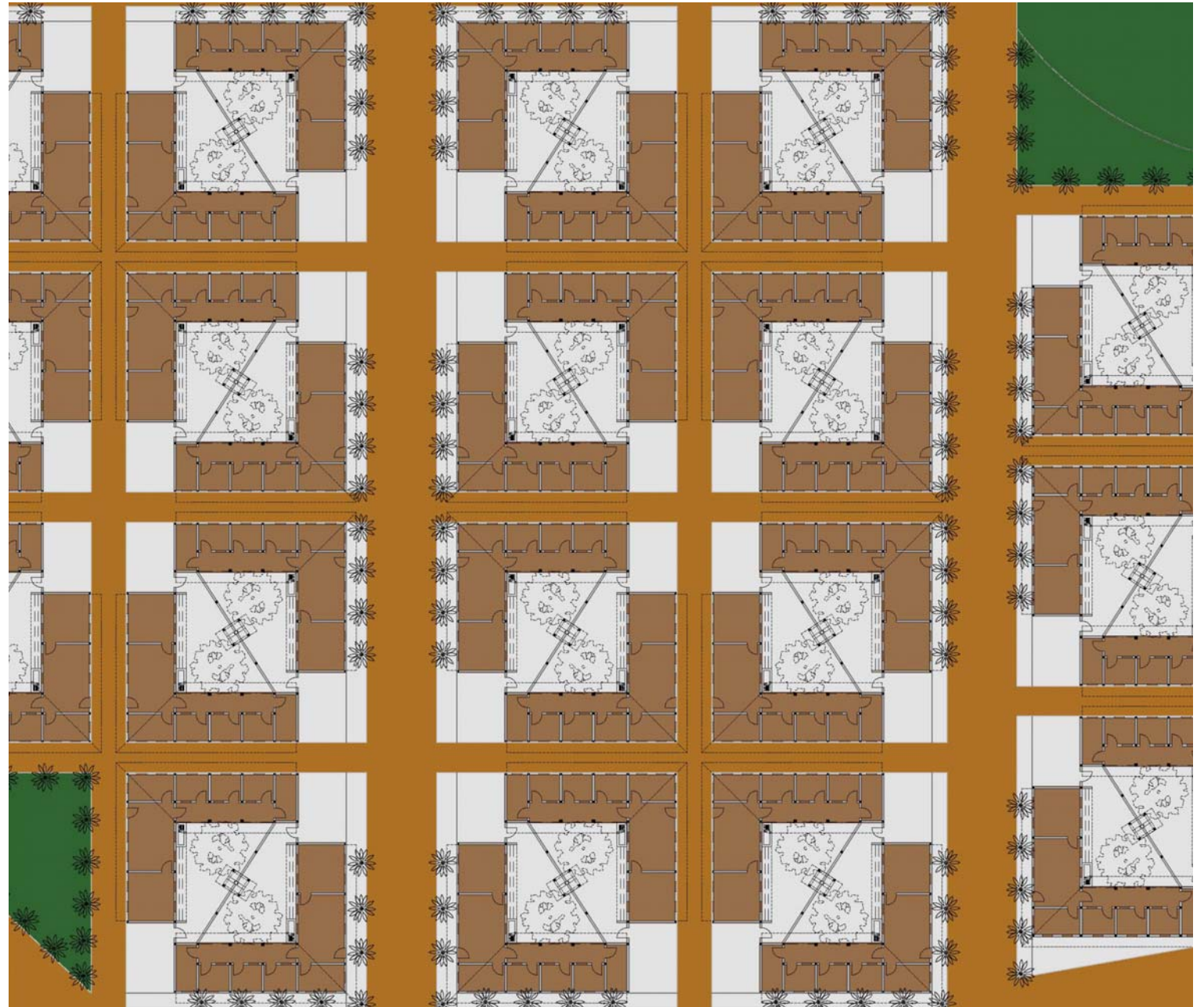
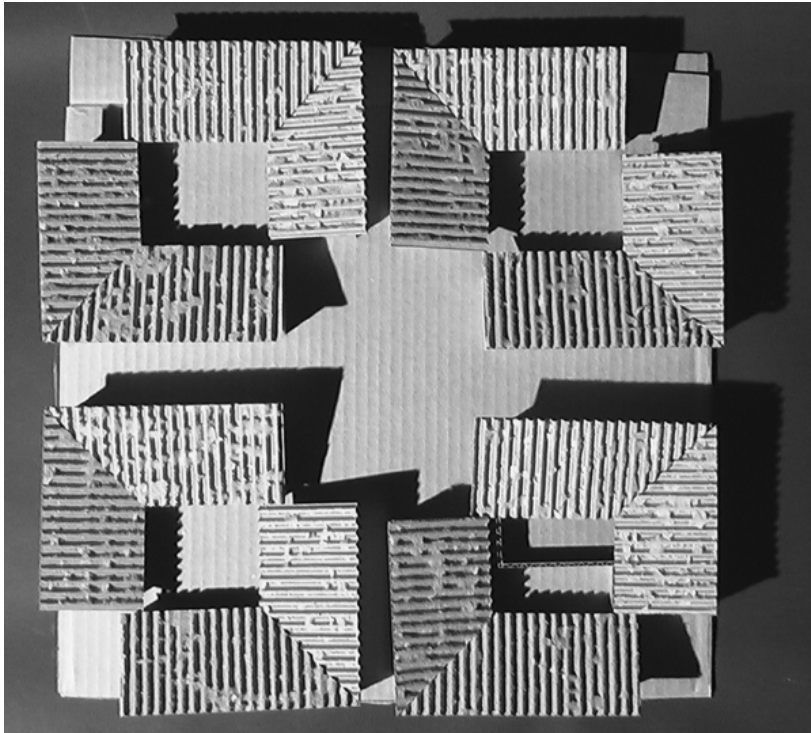
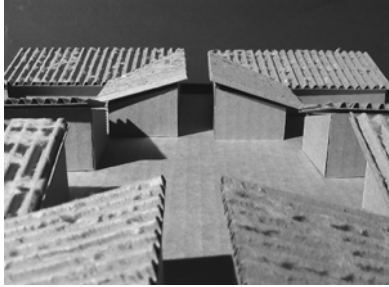

HOUSING CLUSTER PLAN



F. A design for a plaza

The plaza is the community-level “courtyard” in Esperanza. This is where people go during the day to shop and do business in the surrounding buildings. The trees provide shade while the central fountain aids in cooling the surrounding air. The arcade is a traditional element of Spanish colonial towns and also provides shade to walk in during the hot months. During the rainy season, the arcade provides shelter from the elements.

In the evening, residents enjoy gathering and interacting with others, dining in the restaurants, enjoying a night away from the house.

The community will build the market buildings as needed during “Phase II”.

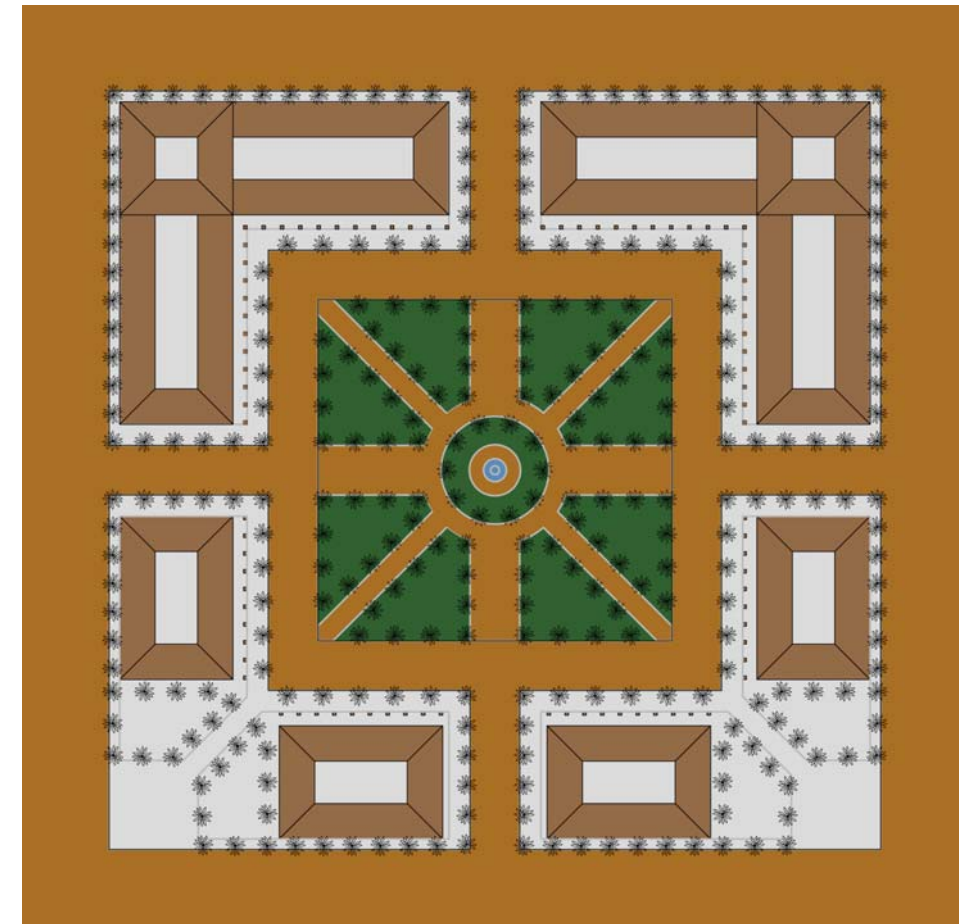
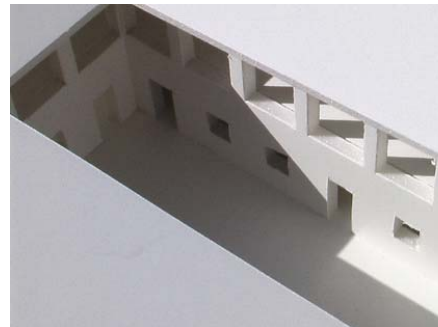

G. A design for a church

The church at the spiritual “head” of Esperanza is a blend of traditional and modern forms. In accordance with traditional Spanish colonial design, the church is located at the highest part of the site. As one approaches, one is greeted by a colonial arcade much like the arcade surrounding the plaza. This arcade signifies the break between the traditional and the new, and between the everyday and sacred. As one moves past the arcade into the church forecourt, the traditional forms are left behind. The two side walls of the church diverge, much like an old camera lens, to accentuate one’s focus on the north wall. The openings of the north wall are such that the structure between the openings forms a crucifix, upon which Christ is nailed. As one gazes out the window, one sees the mountains of Tegucigalpa behind. Enhancing the spiritual, otherworldly nature of this wall is the separation of the wall from the floor plane. Christ appears to be floating on a wall that is not attached to the main body of the church. The gradient colors of this wall suggest blood and at the same time gold.

The cemetery is to the north of the church, bordered by trees. To the southeast of the cemetery is a meditation garden with a fountain which is filled by rainwater from the church roof. The outdoor worship space is to the east of the main church, which also accords church members beautiful views of the mountains during services.

This church is an expression of the advancement of the town and will be constructed in “Phase III”. After building houses and market buildings, the residents will have sufficient expertise to construct a house of worship that is of an advanced nature. It will be the cultural center and pinnacle of the town, fully expressing the meaning of Esperanza, or Hope.

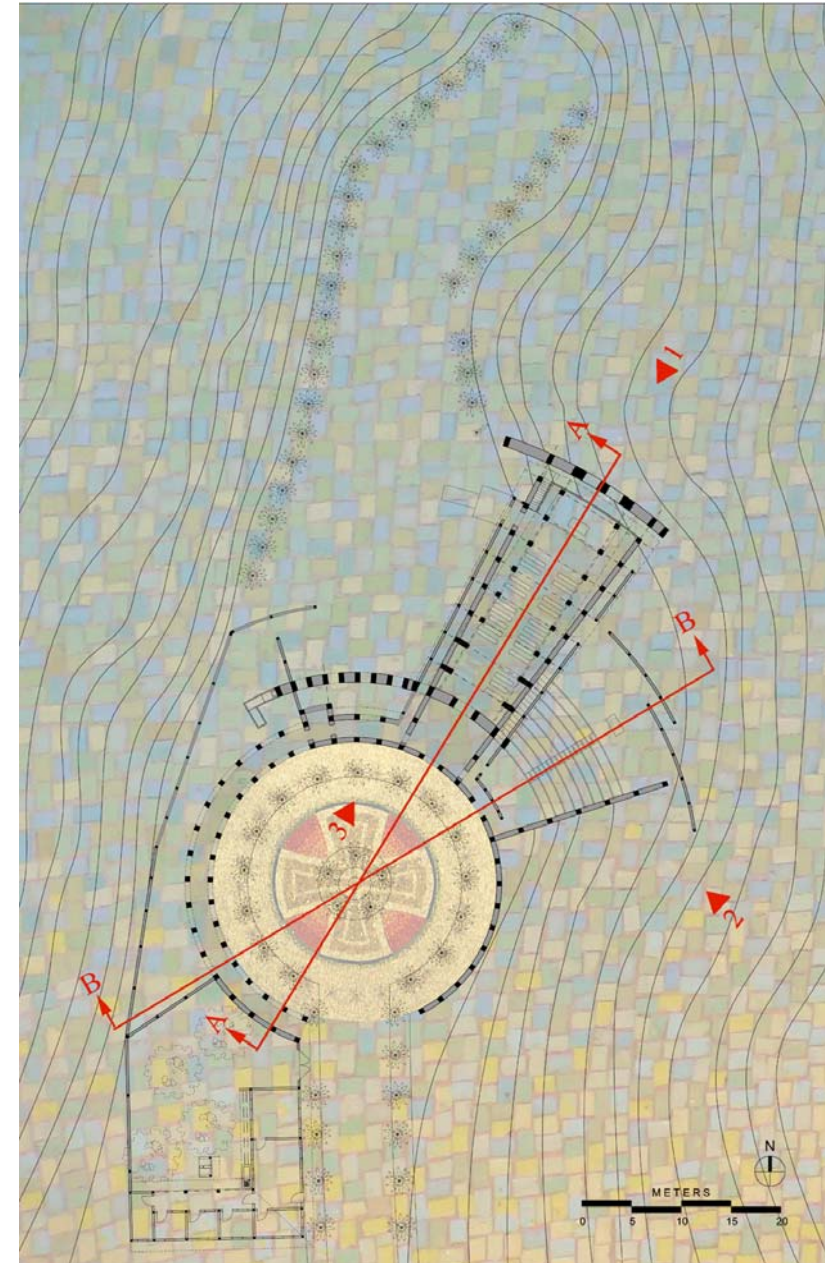

CHURCH KEYPLAN

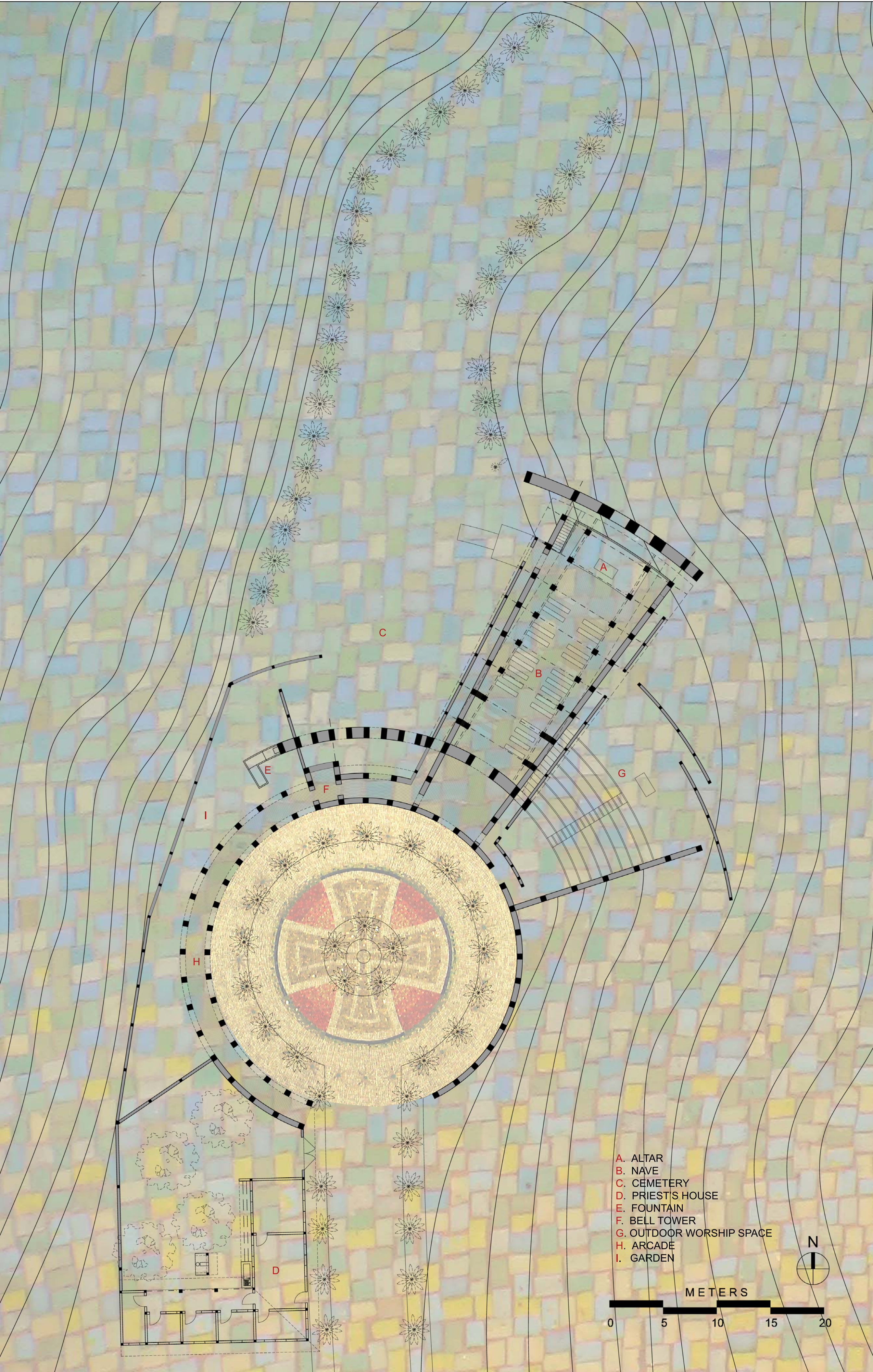

- A. ALTAR
- B. NAVE
- C. CEMETERY
- D. PRIEST'S HOUSE
- E. FOUNTAIN
- F. BELL TOWER
- G. OUTDOOR WORSHIP SPACE
- H. ARCADE
- I. GARDEN

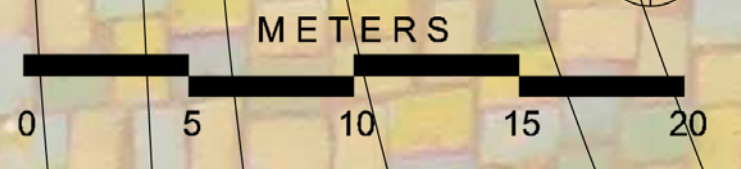



ELEVATION 1



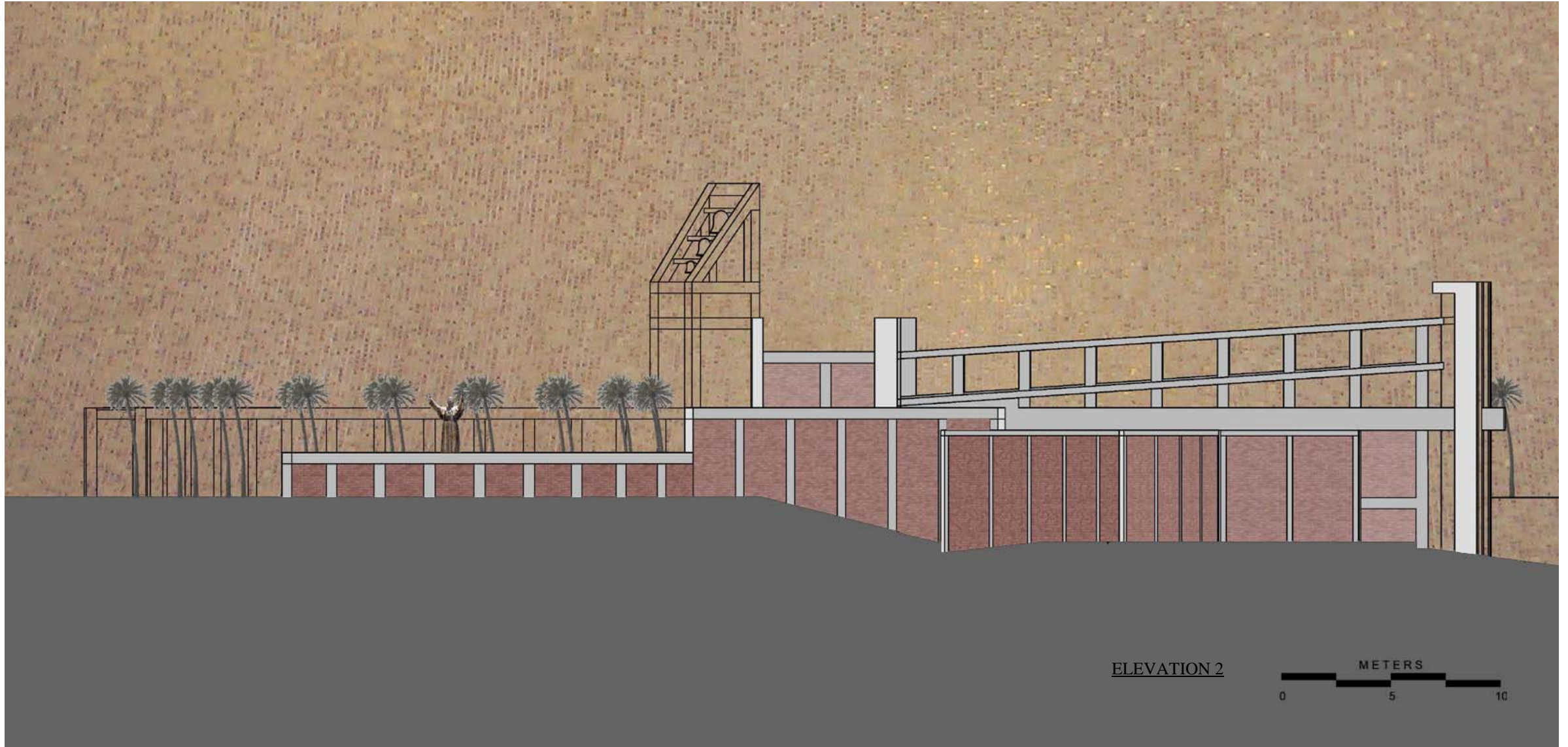



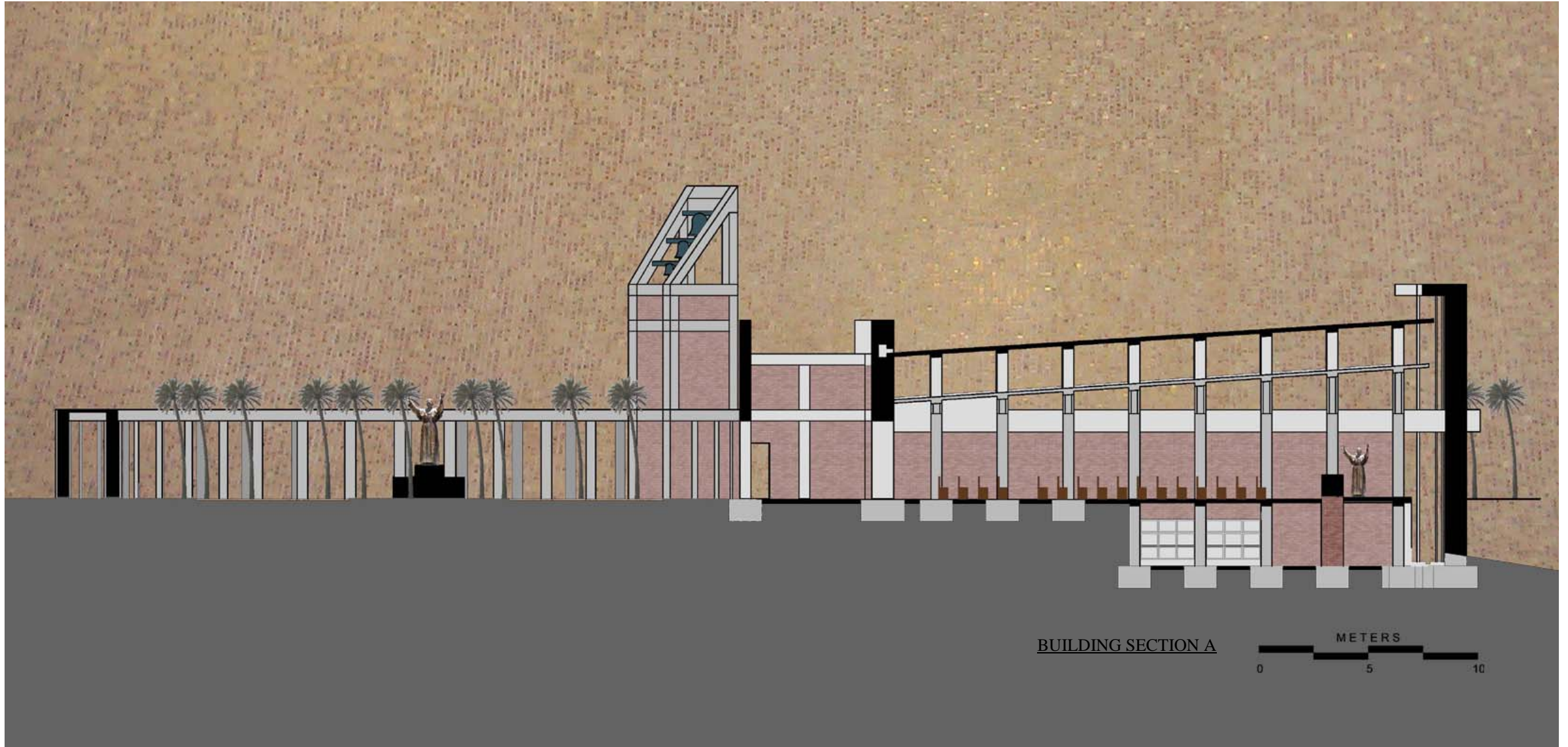

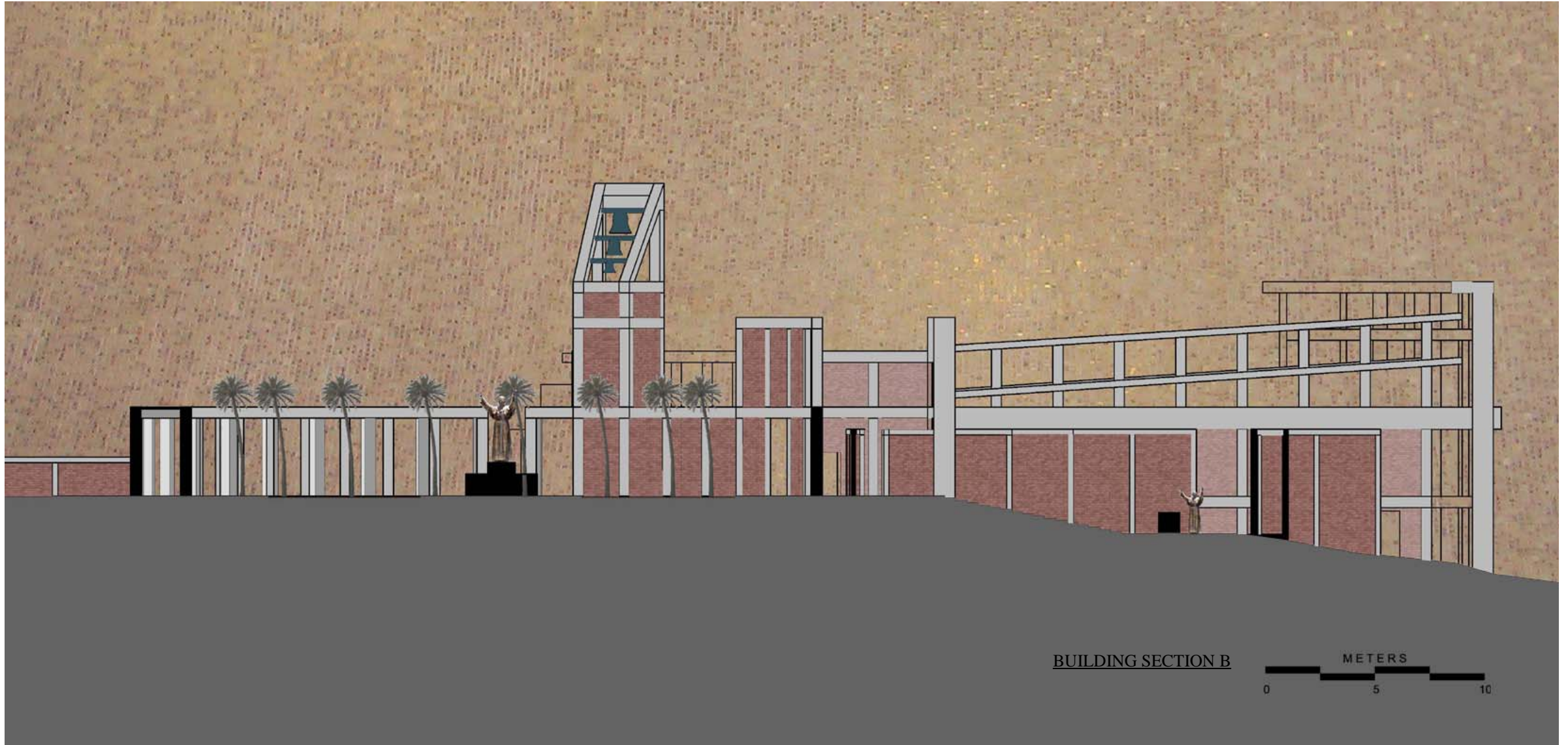



SOUTH WALL SECTION

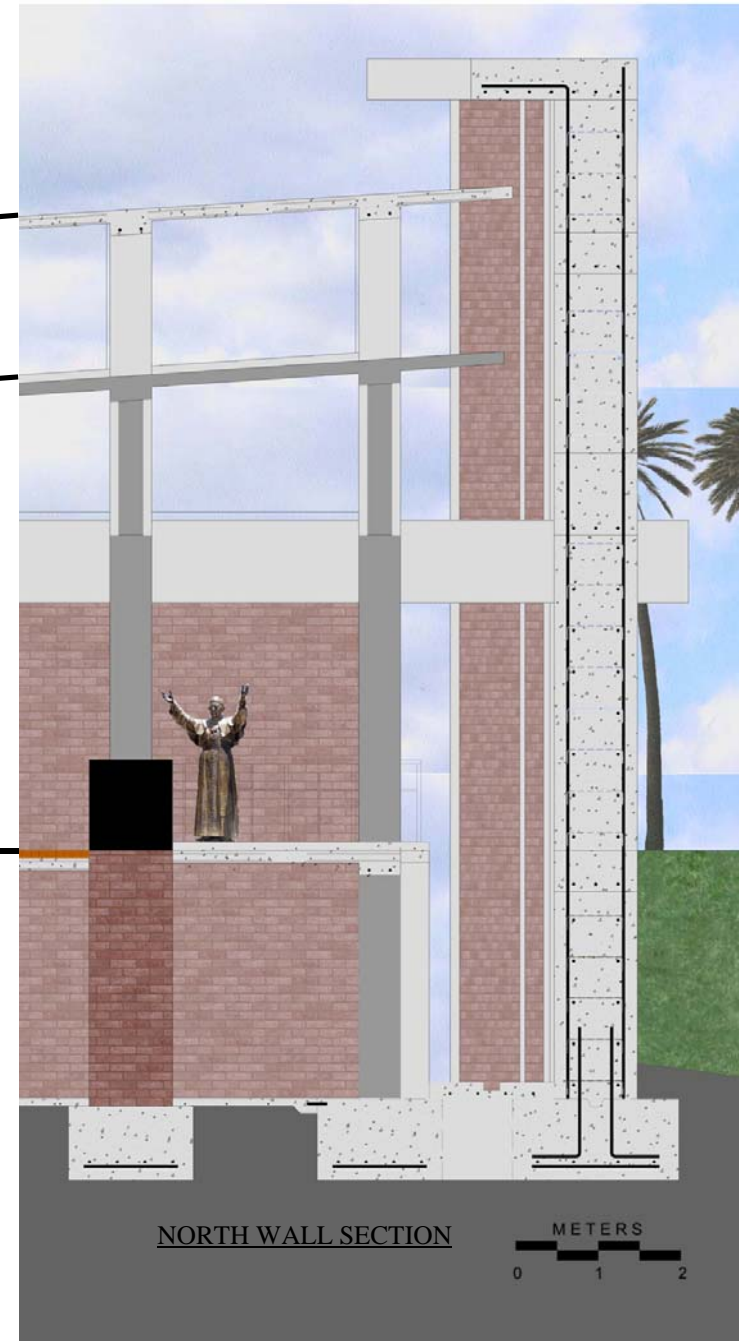
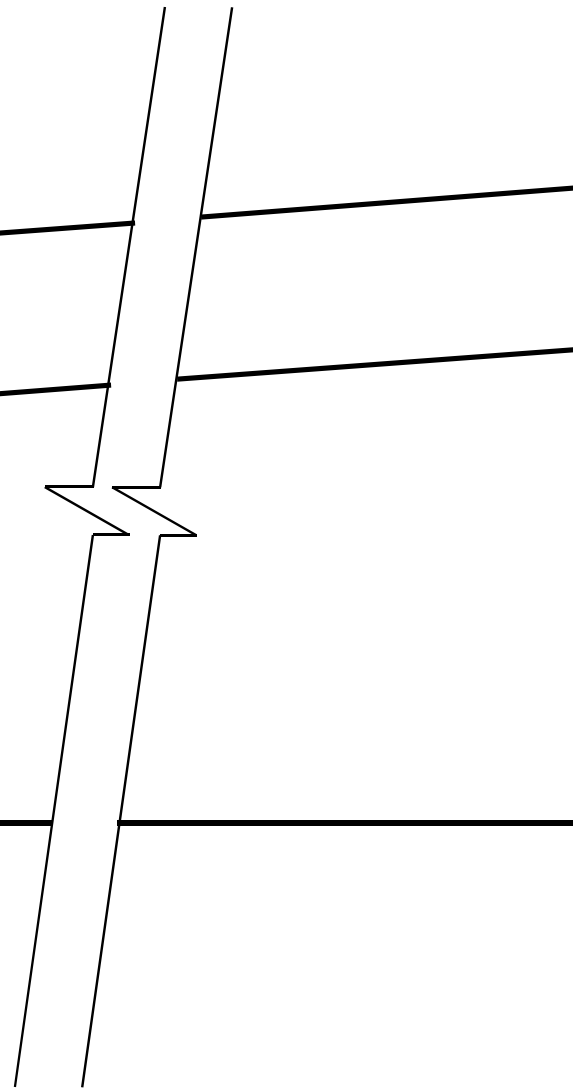

NORTH WALL SECTION

METERS
0 1 2

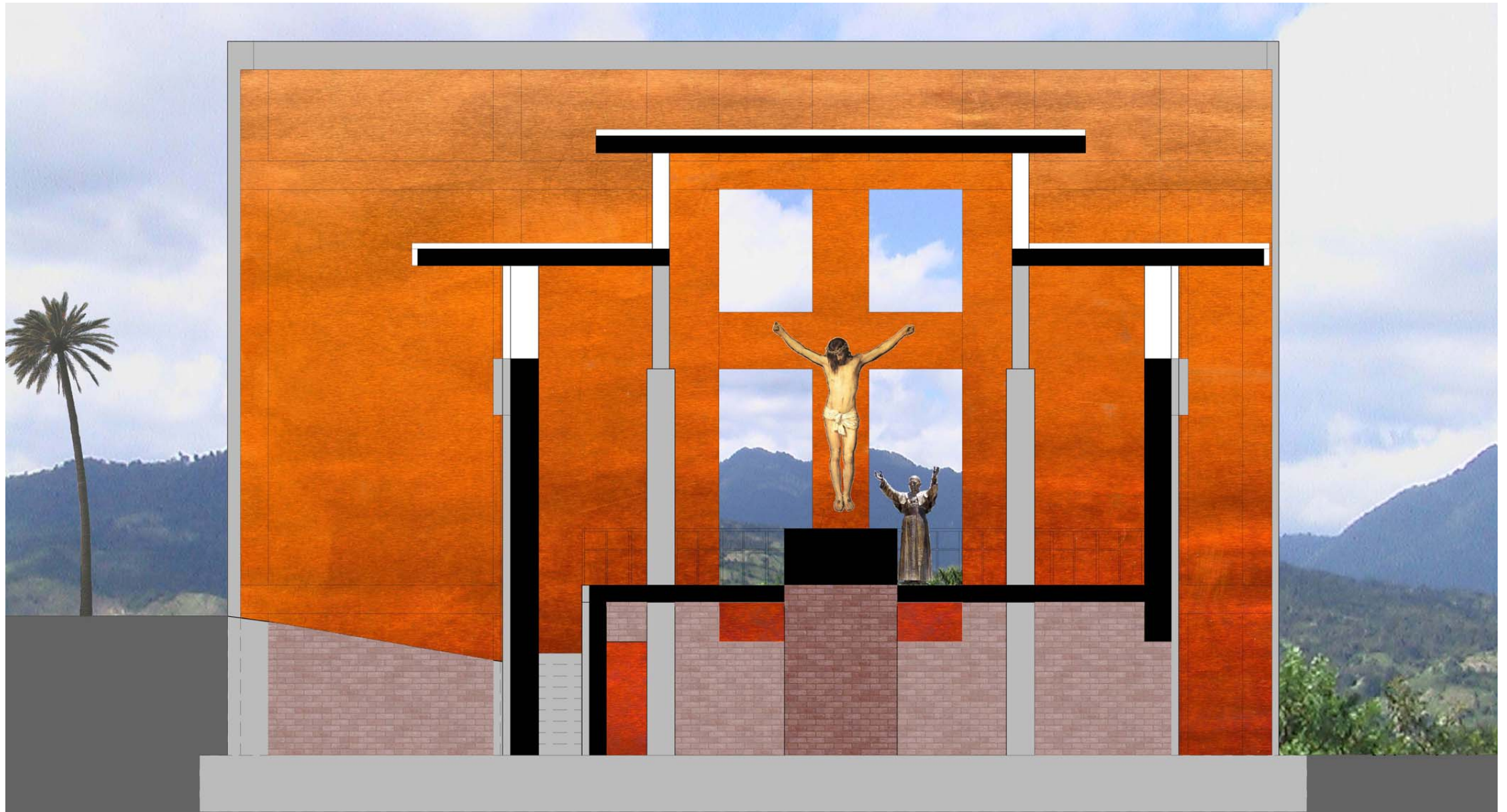

NORTH WALL INTERIOR ELEVATION



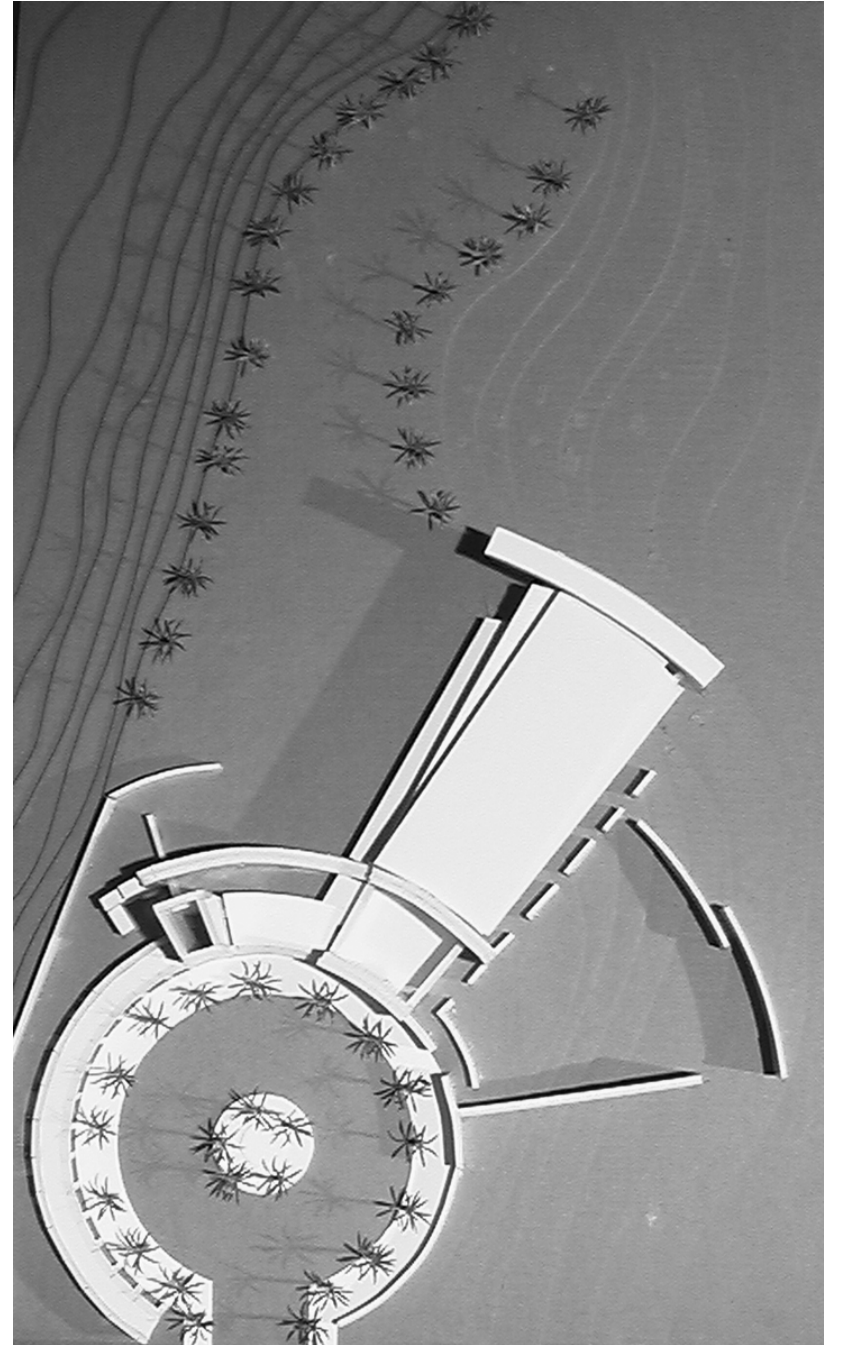
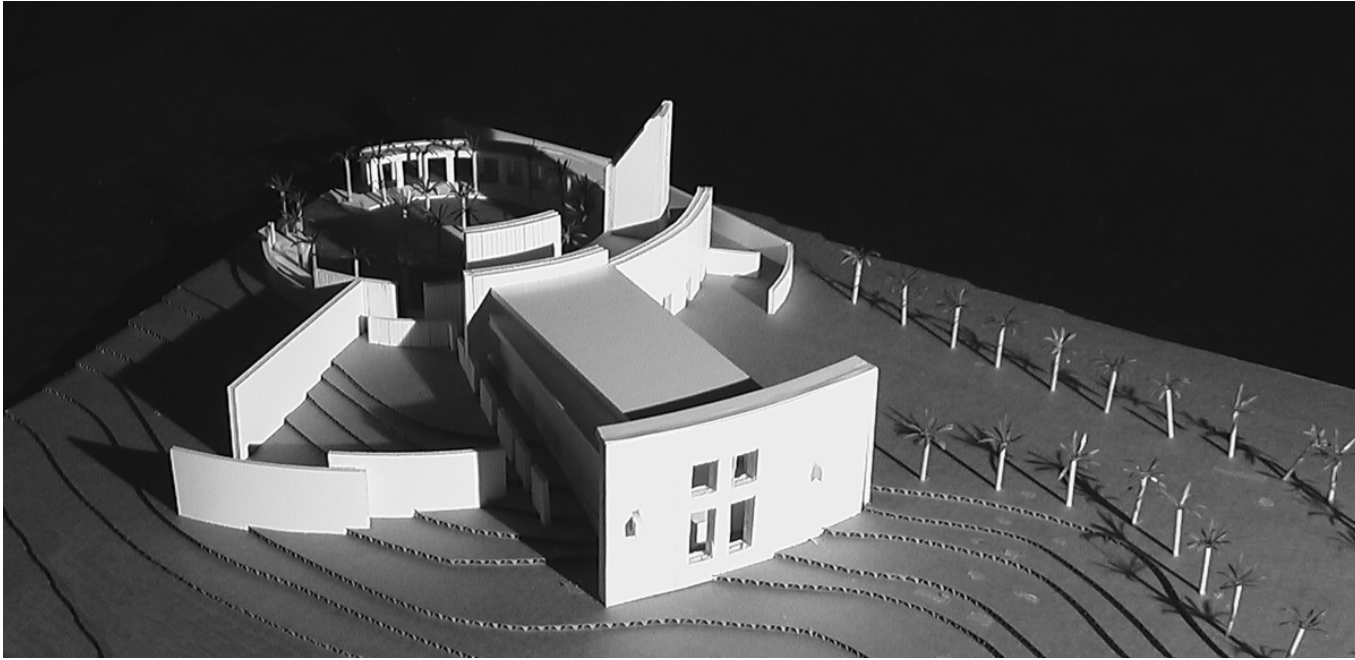

V. Conclusion

The architect's job is to solve problems, whether the problem is how to make an addition to a client's house or whether the problem is how to provide basic shelter to those without it. In this thesis, I chose to focus on the latter extreme of design for human habitation. This project is one that belongs exclusively to its context. Almost everything about it would feel and look differently if it were in the U.S. The materials I chose to work with are materials that are local to the site. The method of manufacture is not especially modern. The way in which the materials are put together depends almost exclusively on human labor. Nothing comes pre-made from a factory, except the corrugated metal used on the roofs. This decision was due to the economic background of the clientele for whom I was designing, who are the most desperate of the poor. The size of the problem of poverty throughout the world and the reasons for why people are living like this is blamed on overpopulation, the way the "system" works, etc. This can lead some to say that it's just too big, too much, too daunting. To me, this reasoning is just an excuse to do nothing. I may not be able to do much, but I can do *something* as an architect, as a member of the human community. If it's only helping one person, then that's one person less who has to suffer. If someone reading this thesis decides not to retreat behind the curtain of their comfortable lives, but to help those who suffer, then I have contributed to the solution of the problem. I say this not to cause guilt, but to persuade the reader to think about how they could help those unfortunate enough to be born with a lack of opportunity. As a lone architect, I need others to help. I need others to look, to listen, and to give of themselves. I need people who are in positions of power to use their influence to get land donated to help people get started, to get programs in place to have a systematic method so that there is a clear path with concrete results from poverty to self-sufficiency and dignity. This is my reason for doing this thesis. This is where my interest lays.

VI. Bibliography/Credits

1. Alexander, Christopher. A Pattern Language: Towns, Buildings, Construction (Center for Environmental Structure Series). New York: Oxford U P, 1977.
2. Bell, Bryan. Good Deeds, Good Design. New York: Princeton Architectural P, 2004.
3. Calvino, Italo. Invisible cities. Trans. New York: Harcourt, 1974.
4. Cullen, Gordon. The Concise Townscape. London: Van Nostrand Reinhold, 1961.
5. Cuny, Frederick. Famine, Conflict and Response: A Basic Guide. West Hartford, CT: Kumarian P, 1999.
6. Dean, Andrea O. Rural Studio: Samuel Mockbee and an Architecture of Decency. New York: Princeton Architectural P, 2002.
7. Fathy, Hasan. Architecture for the Poor: An Experiment in Rural Egypt. Chicago: U of Chicago P, 1973.
8. Katz, Peter. The New Urbanism: Toward an Architecture of Community. Portland, OR: Print Vision, 1994.
9. Khalili, Nader. Ceramic houses and earth architecture : how to build your own. Hesperia, CA: Cal-Earth Press, 1990.
10. Kostof, Spiro. The City Shaped. Boston : Little, Brown, 1991.
11. Lobell, John. Between silence and light : spirit in the architecture of Louis I. Kahn. Boston: Shambhala, 1979.
12. Lynch, Kevin. The Image of the City. Cambridge: MIT P, 1960.
13. Macintosh, Duncan. The Modern Courtyard House: A History. London: Lund Humphries for the Architectural Association, 1973.
14. Mazria, Edward. The passive solar energy book : a complete guide to passive solar home, greenhouse, and building design. Emmaus, PA: Rodale P, 1979.
15. McHenry, Paul Graham Jr. Adobe and rammed earth buildings : design and construction. Tucson: U of Arizona P, 1984.
16. Oliver, Paul. Dwellings : the house across the world. Austin: U of Texas P, 1987.
17. Polyzoides, Stefanos. Courtyard Housing in Los Angeles : A Typological Analysis. Berkley: U of California P, 1982.
18. Randhawa, T. S. The Indian Courtyard House. New Delhi: Prakash Books, 1999.
19. Reps, John W. The Making of Urban America; a history of city planning in the United States. Princeton: Princeton U P, 1965.
20. Reps, John W. Town Planning in Frontier America. Princeton: Princeton U P, 1969.
21. Rogers, Richard. Cities for a small planet. Boulder, CO: Westview P, 1997.
22. Rudofsky, Bernard. Architecture Without Architects : a short introduction to non-pedigreed architecture. Albuquerque: U of New Mexico P, 1987.
23. Rykwert , Joseph. The Idea of a Town. Cambridge: MIT P, 1988.
24. Scully, Vincent. Architecture : the natural and the man-made. New York: St. Martin's P, 1991.
25. Scully, Vincent. Pueblo/Mountain, Village, Dance. New York: Viking P, 1975.
26. Solomon, Barbara Stauffacher. Green architecture and the agrarian garden. New York: Rizzoli, 1988.
27. Steele, James. An Architecture for People: The Complete Works of Hassan Fathy. New York: Whitney Library of Design, 1997.
28. Steele, James. Hassan Fathy. London: St. Martin's P, 1988.
29. Steele, James. Sustainable architecture. New York: McGraw-Hill, 1997.
30. Steen, Bill, and Athena Steen. Built by hand : vernacular buildings around the world. Layton, UT: Gibbs Smith, 2003.
31. Steven Winter Associates. The Passive Solar Design and Construction Handbook. New York: Wiley, 1998.
32. Turner, John F. C. Housing by people : towards autonomy in building environments. New York: Pantheon Books, 1977.
33. Wilbaux, Quentin. Marrakesh : the secret of courtyard houses. Courbevoie, France: ACR, 1999.

ALL ILLUSTRATIONS AND TEXT ARE BY THE AUTHOR, EXCEPT WHERE NOTED.

VII. Appendix

Appendix A: The author is unable to locate the original copyright holder for this material and includes this work under *Fair Use* copyright laws.

CINVARAM BLOCK PRESS

Contact Agency: Inter-American Housing Centre, Bogota, Colombia.

Introduction: There has always been a need for a single low cost, portable machine for making building blocks and tiles from common soil. The cinvaram machine, developed by Inter-American Housing Centre in Bogota, Colombia, fulfils this requirement. It has since been used extensively in developing countries including India. The blocks and tiles made from this machine have several advantages. They are easy to make, are cheap, can be easily handled, and need no baking. Transportation costs are avoided since the machine is portable and the blocks are made near the construction site.

Equipment: Ginvaram block press, shown in fig. 7, weights 63 kg., and has a dimension of 24 x 37 x 64 cm. Other particulars are as follows:

Application force of lever	36 kg.
Bearing strength of fully cured blocks	14-35 kg./cm.2
Size of block	9 cm. x 14 cm. x 29 cm.
Size of tile	5 cm. x 14 cm. x 29 cm.
Average number of blocks or tiles made by 2 workers per day	300 – 500
Average number of blocks needed for a Two room house	2500
Average number of blocks per 50 kg. of cement	150
4 different moulds for different kinds of blocks and tiles are available.	
Other equipment needed:	
1 wide-mouth glass jar	
6 mm. to 10 mm. mesh wire screen	
Box, inside diameter (60 x 4 x 4) cm.	
Fine sieves	
Suitable mixing boards (120 x 250 cm.) and (250 x 250 cm.)	
Bottomless measuring box	
Bottomed measuring box	
Shovels	
Sprinkling can	
Mounting board (250 x 20 x 5) cm.	
4 bolts 1.5 cm. dia. x 8 cm. long	
8 workers are required for one machine	

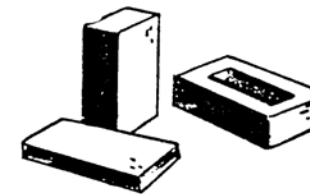

Blocks and Floor Tiles

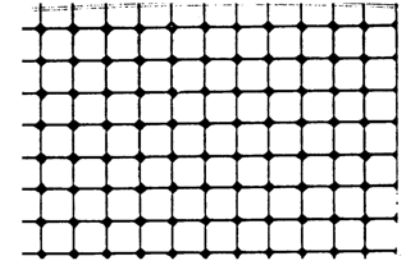

1/4" mesh: actual size –

PREPARING THE EARTH

Only the simplest of implements are required to properly prepare the selected earth.

SCREENING THE EARTH

The selected earth must be screened through mesh having openings of about 1/4" square.

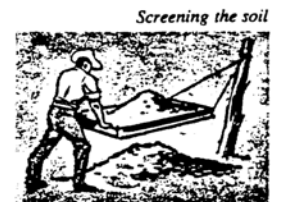

Screening the soil

ADDING THE CEMENT

Depending upon the intended use of the blocks and the climatic conditions, excellent results can be obtained with 5 to 10 percent cement. After screening the earth, sprinkle the measured amount of cement evenly and mix thoroughly. Generally, a higher percentage of cement will result in a block having greater resistance to erosion, absorption, and abrasion.

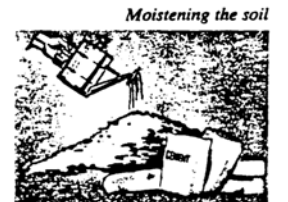

Moistening the soil

NOTE: Lime may be substituted for Cement, but in doing so, double the quantity of Lime used and also double the Curing Time of the Blocks or Tiles.

MOISTURE CONTENT

The amount of moisture in the earth mixture is one of the *most important requirements*. A simple test to determine the correct amount of moisture in the mix is to squeeze a ball of the soil mix in your hand. If the ball can be broken in two without crumbling and without leaving any moisture on your hand, the moisture content is correct. Should the mix be too dry, sprinkle small amounts of water evenly and mix thoroughly until it is of the right consistency.



determining the dampness

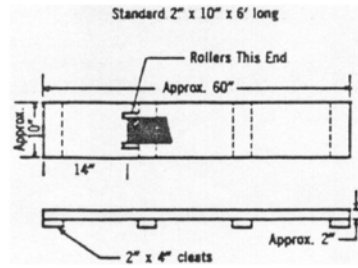

MOUNTING THE PRESS

The press must be attached to a wooden baseboard for necessary stability.

OPERATING THE PRESS

In order to make good compressed earth blocks and tiles, enough earth mix must be loaded into the mold box to require a *hard pull* on the handle. Make a few test blocks and tiles to determine the quantity of your earth mix which must be loaded into the press to give you this adequate, hard pull.

There are three basic operations in making the compressed earth blocks or tiles:



1.



2.

1. Loading the mold box.
2. Compressing the mix.
3. Ejecting the finished product.

Detailed Movements

1. Place the handle in the rest position and open the mold box by swinging the cover horizontally until its stop is reached; then fill the mold box with the prepared earth.
2. Close the mold box, skimming off excess earth, and bring the handle to the vertical position; then release the latch.
3. Pull down the handle until it is parallel with the ground. This applies the necessary pressure to form the block. If the mold box is properly filled, this should require a "hard pull".

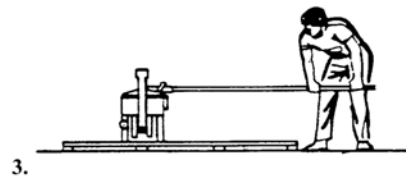

3.

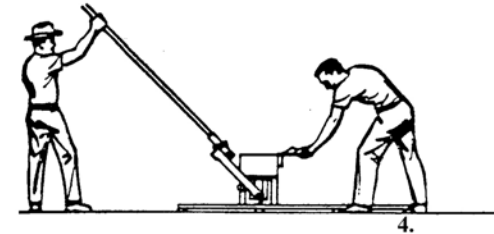

4.

4. Return the handle to the original rest position, swing cover back and open the mold box.

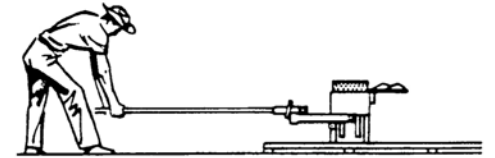

5.

5. Pull down on the handle in the opposite direction until it is parallel with the ground. This ejects the block.

- 6a. *Removing blocks from the press:* Place hands flat at the ends of the block, being careful not to damage the corners or edges and then gently lift the block from the mold box. Place on edge at the curing site.

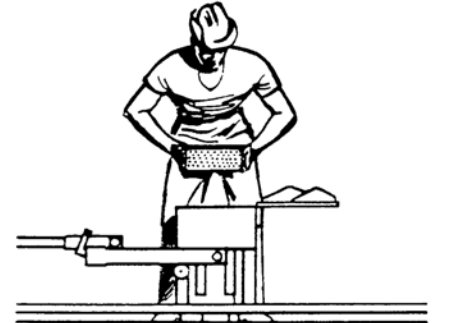

6a.

- 6b. *Removing tiles from the press:* Place one flat hand on top of the tile. Keeping the tile and wooden insert together, slide both off the mold box until the other hand can be placed beneath the insert. Place both on edge at the curing site and then gently separate the Insert from the tile.

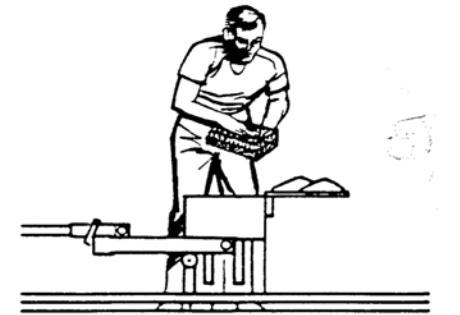

6b.

NOTE: One of the greatest advantages of a compressed earth block or tile is that it can be removed immediately from the press without the use of a pallet.

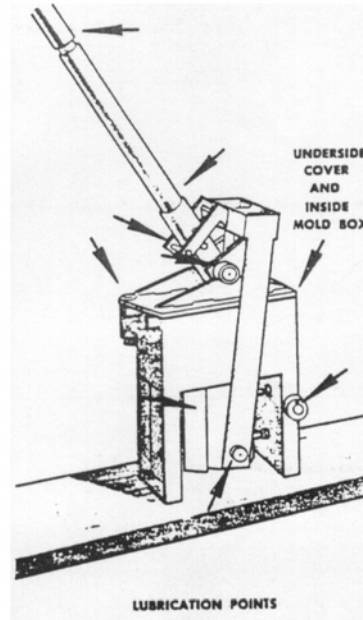

LUBRICATING THE PRESS AND ACCESSORIES

Before and during operation, oil all moving and wearing parts; especially the underside of the steel cover, the inside of the mold box, the metal face of the insert, and the wooden form. FREQUENT oiling of the form and insert DURING OPERATION will prevent finished blocks and tiles from sticking when removing them from the press. A light coating of oil over the entire press after operation or during storage for long periods of time will keep it free from rust.

MAKING BLOCKS AND TILES

To make a solid block, do not use the wooden form or the insert. Remove both from the mold box. If the wooden form is attached to the piston head, it can be released by removing the two screws at the top of the wooden form.

To make a semi-hollow block, attach only the wooden form to the piston head by means of the two screws supplied.

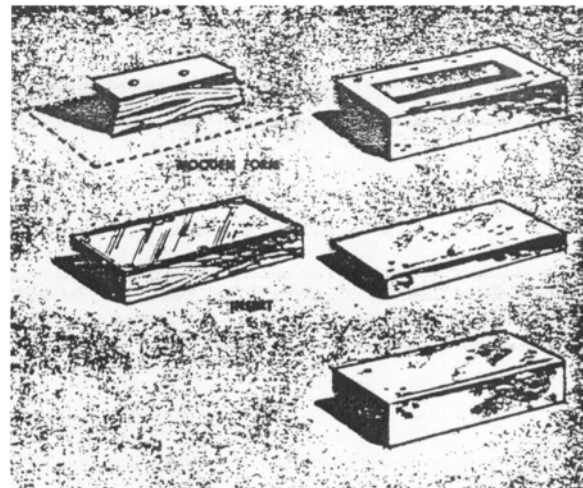

To make a tile, place only the insert at the bottom of the mold box, *Metal face up*.

NOTE: Each Cinva Ram comes equipped with 5 inserts to fabricate blocks for field drains, grilles, lintels, shelf-supports, conduits and pipes, as well as semi-hollow, tile, and half blocks.

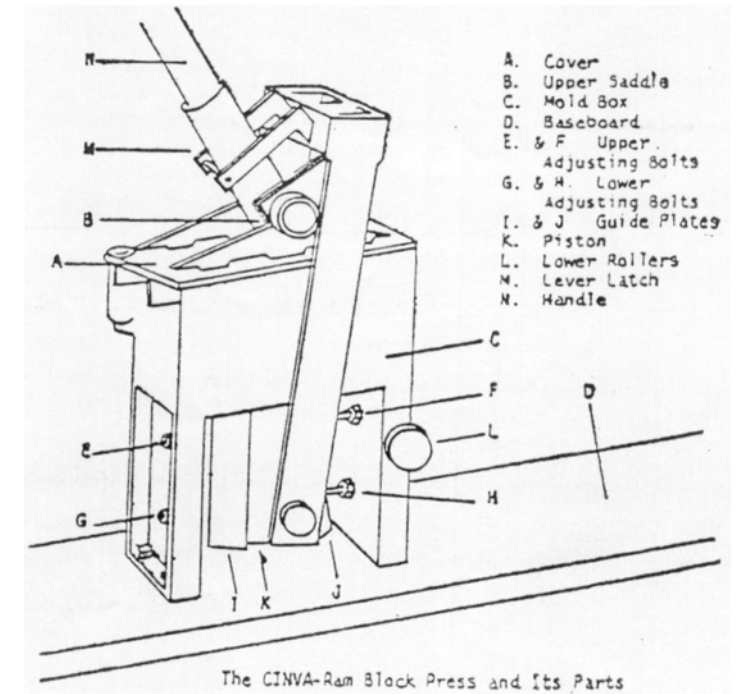

The CINVA-Ram Block Press and Its Parts

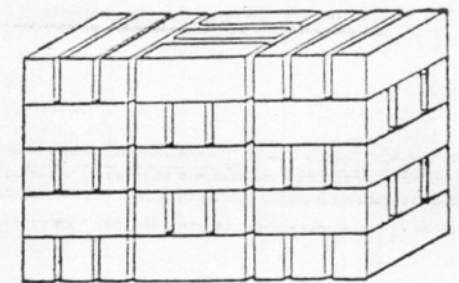

Blocks stacked for 10-day cure

DISPOSAL SYSTEMS

THE IMPORTANCE OF THEM:

Man himself is the reservoir for most of the diseases that incapacitate or kill him, and the improper handling of his wastes is the cause of many of these diseases. These diseases include CHOLERA, TYPHOID, PARATYPHOID FEVER, DYSENTERY, HOOKWORM, and other parasitic infestations. All of these diseases are controllable through good sanitation and the proper disposal of wastes. Yet of the nearly 6 billion people in the world 2 to 3 billion have no safe sanitation system.

TRANSMISSION OF DISEASE FROM WASTES:

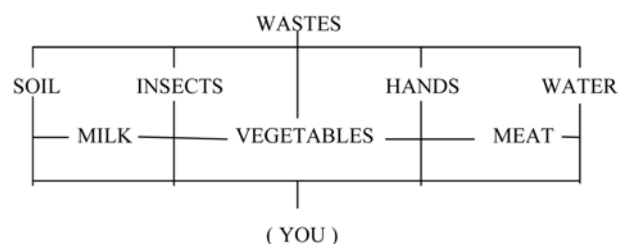

The transfer of many diseases follows these paths:

1. Causative agent ----- (which gets into #2.)
2. Source of Infection ----- WASTES-FECES
3. Way of Escape ----- SOIL, WATER, HANDS, FOOD
4. Mode of Entry into Host ---- MOUTH, SKIN, EYES, NOSE
5. Susceptible Host ----- YOU

If any one of these paths can be cut, the problem is greatly reduced. The easiest solution is to control the **source of infection** at its source. This is the first real opportunity because at each step down the chain, it becomes more difficult.

RURAL METHODS OF WASTE DISPOSAL:

Of the systems available, only the PRIVY SYSTEMS or the COMPOSTING TOILETS need to be seriously considered. These consist of a number of variations based on a hole in the ground, where wastes are disposed of safely. With a minimum of attention to location and construction, there will be little pollution of SOIL, surface water or ground WATER. This solves much of the problem of exposure to infectious disease causing material.

1. SLIT TRENCH:

This system consists of a hole in the ground sufficiently deep to permit covering with dirt 2 ft. deep after full. This system has tremendous advantages over the typical no facilities system, and will provide a notable improvement in the general health of the community IF USED BY ALL of the people in the area. It has serious drawbacks but is still a big improvement over not having any organized waste disposal system.

2. OUTHOUSE:

This system is similar to the slit trench with the addition of some physical structure over the hole or pit to limit access to the hole by flies, water, and unwanted animals, which may spread disease.



3. WATER SEALED LATRINES:

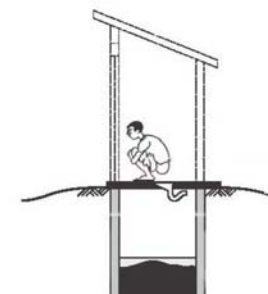

A. Typical Water Seal - This system consists of a hole in the ground that has been covered by a concrete slab, which is constructed in such a way as to provide an air tight seal made of water. This is the ultimate privy system and is even suitable for use in the interior part of a house. There are two varieties, wet and dry pit.

B. Aqua Privy (sewage sealed) - This system is relatively expensive to build because it requires a watertight tank and a leach field or seep pit. The [Diagram #1 Aqua Privy](#) is one form of this system, and there is an example problem using this design

following the section, Aqua Privy latrine system.

4. COMPOSTING TOILETS:

This system provides a good, safe environment in which natural aerobic and anaerobic decomposition of the wastes may take place out of the reach of man, animals, insects, soil and water. Diagrams on [Composting Toilets](#) are sample forms of this system and works well if there is good percolation in the soil & the pits are completely separate. Night soil has a dry weight analyses C/N ratio of (6-10% Carbon & 5.5-6.5% Nitrogen). Urine has .8% Carbon & 15-18% Nitrogen. To enhance rapid composting, you want a C/N Ratio of 30 Carbon to 1 Nitrogen. This means some outside carbon must be added. The Ideal

temperature for composting is 120-158° F. The moisture content should be above 30% for an aerobic decomposition to take place.

5. AIR SEAL LATRINE CONSIDERATION:

The cones that work Mac's designs 1982 – These devices have been incorporated into many different latrine systems successfully. **It WORKS GREAT**, is low cost & greatly reduces insects & odor problems. The cone also eliminates the common problem of over filling the pit. The normal hole in the floor is reduced to 3 1/2in by a cone that extends 15in. below the floor. A chimney is installed with 2 times the cross sectional area of the floor holes and all other air leaks into the pit. The chimney should be located on the warmest side of the building; it should be 2ft. taller than the peak of the roof; it should vent the highest point in the floor cover over the pit. The chimney is screened in such a way as to allow flies to enter & not to leave. This is accomplished by taking a piece of screen wire and forming it into a cone 2-1/2 times as long as it is across the opening at the top, with an opening at the smaller end that is about 1in. across. This cone is inserted pointing down into the chimney pipe. Some sort of cap should also be installed to prevent debris from plugging the cone.

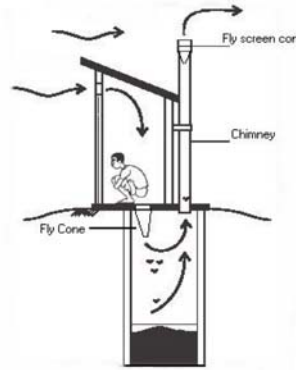

SOIL & GROUND WATER POLLUTION

Knowing how wastes pollute soil and ground water provides valuable information for the design of disposal systems. After wastes are deposited on the ground or in pits, the bacteria (which are unable to move far by themselves) may be transported horizontally or downward into the ground by water in the form of rain or run off or by urine itself.

The distance that bacteria travel in soil varies widely. The greatest influence being the porosity of the soil and the amount of liquid involved. The horizontal movement of this material is usually less than 3 ft. the vertical travel is less than 30 ft. (in open pit privies that are exposed to the rains). In the covered latrine it is somewhat less if water is not added. When the contamination does not directly enter the ground water, there is practically no danger of contamination of water supplies.

On the surface, only the earth immediately surrounding the site is likely to become contaminated if it is not carried off by surface water, blown away by the wind, or picked up by flies (or other insects), or carried off on the feet of animals. Pigs are often responsible for redistributing feces over a wide area.

Harmful bacteria do not usually find soil to be a good place to multiply and will usually die within a couple of days (depending upon the amount of moisture available). However, some of the worms, hookworm for instance, may live for many months. And these are picked up by contact with the skin: don't go barefoot in areas where human wastes are deposited on the surface.

HOW FAR AWAY IS SAFE:

Though there is no cold, hard rule governing the safe distance between waste disposal sites and surface or well water collection points; adhering to the following will greatly reduce your chances for having trouble:

1. Locate latrines DOWN hill from wells and springs.
2. Locate latrines at least 100 ft. from any water source.
3. Locate latrines in soil, not in rock formations.
4. Locate wells and privies in places that are well drained and not subject to surface water runoff or flooding.

HOW BIG OR DEEP SHOULD THE PRIVY PIT BE DUG:

The accumulation of solid wastes in a wet pit latrine is about 1.5 cu. ft. per person per year. This figure does not take into account the medium used to wipe oneself. Assuming the normal materials - cornhusks, cobs, grass, coconut husks and the like, a figure of 2.2 cu. ft. would be more realistic.

WET VERSUS DRY PIT TYPES:

The rate of decomposition in the dry privy is about half that of the wet variety, so you must increase the figure for the amount of solid accumulation in the dry privy to be about 1/3 greater than that of the wet type, i.e.

Wet	figure 1.5 cu.ft. - no wipe material
	figure 2.2 cu.ft. with normal vegetable materials
Dry	figure 2.0 cu.ft. - no wipe material
	figure 2.7 cu.ft. with normal vegetable materials

Composting figure 8.0 cu.ft. - no wipe material
figure 8.7 cu.ft. with normal vegetable materials

DESIGN OF A BASIC LATRINE PIT:

Design the pit so that it will be filled at the same time the house covering it will wear out, or shortly thereafter. The average little grass shack will need to be completely rebuilt about every 4 years in most places, and if the floor is made of sticks covered with mud, it will probably be rotten by then also. Digging a hole for a privy that will last 4 years is not quite so ominous a task that it may not seem worth the trouble. If you design a good ROUND concrete slab floor, it will roll to the new location without too much trouble when the time comes. On the other hand, if the building is brick or adobe it will last a long time, and it would be a shame for the pit to fill up too soon, so think it all out carefully.

COMPOSTING TOILETS:

The composting toilet, in its simplest form, consists of a covered pit designed to hold feces and limit insects, water, & animal access to it until it becomes safe for use as a fertilizer.

Requirements for two pit types:

1. High ground free from surface and subsurface water encroachment
2. Soil deep enough to avoid consolidated rock.
3. Adequate percolation: The ability to allow the passage of urine and other added water to escape without collecting in the hole.
4. Enough space to allow the filled pit to remain unused for 1 to 2 years before using the compost from it.
5. Lime should be added to the pit if flies larva cannot be controlled. (The lime amends the PH of the pile beyond their livable range.)

Requirements for Clivus Multrum type:

1. Specially designed container capable of holding 3 years worth of waste products.
2. This container has to be kept warm, ventilated in & out, with nearly air tight access doors.

Manufacture Clivus Multrum USA, Inc., 14A Elite Street, Cambridge, Massachusetts 02138

Cross section of Clivus Multrum in place

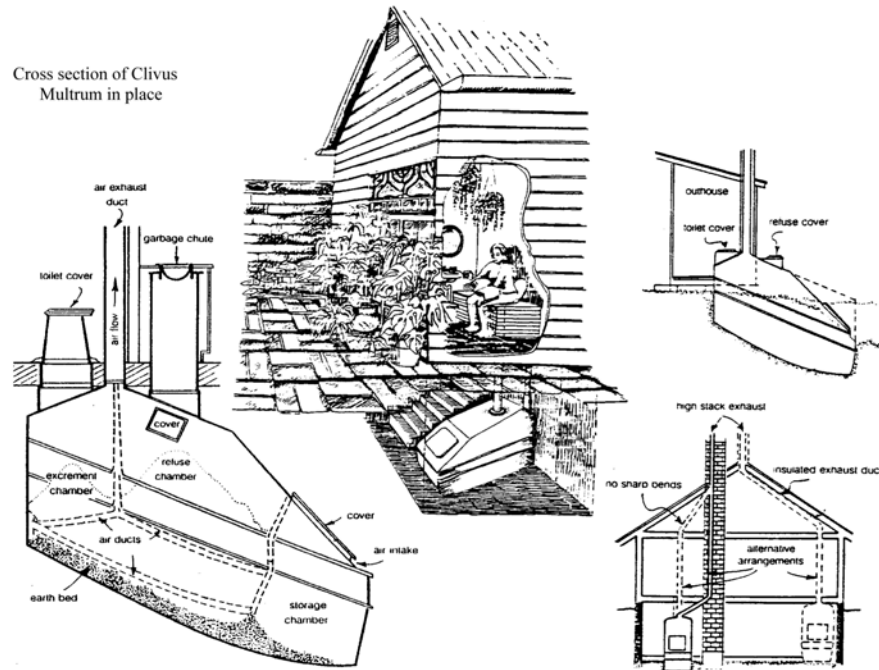

Appendix B: The material in this appendix is reprinted with permission from the Aprovecho Research Center in Cottage Grove, OR.

SIMPLE PLANS TO BUILD THE JUSTA STOVE

The Justa Stove is also known as La Estufa Justa, the Just stove, the Ecostove or El Ecofogon.

How to build one of the new generation of fuel efficient stoves with chimneys.



The Justa (pronounced *Hu-sta*) stove was developed through the coordinated efforts of the people of Central America, Trees, Water, and People, Rotary International and Aprovecho Research Center

Text: by Peter Scott

Illustrations: by Tony Wiley, Brian Thomas and Ethan Hughes

For more information about the Justa Stove or if you would like assistance in designing a stove for your community please contact us at:



Aprovecho Research Center

80574 Hazelton Road, Cottage Grove, OR 97424-9747, USA
 phone: (541) 942-8198 fax: (541) 942-8198
 e-mail: apro@efn.org webpage: <http://www.efn.org/~apro>

BUILDING WITH METAL OR CEMENT

The body of the Justa stove can be built with a variety of different materials, such as cement, clay & sand, brick, adobe, or metal. This guide explains how to construct the stove with brick but other plans are available to build the Justa with cement and metal.



This cement Justa is being built by Helps International in the Guatemalan Highlands. Three individual cement pieces are cast in fiberglass molds and then assembled on site. The molds are easy to transport and prevent design inconsistencies.



This metal Justa with oven is being constructed by Ahdesa in Honduras and by Prolena in Nicaragua. The metal Justa is approx. 30% more expensive but it allows for mass production and ease of transport.

See page 16 for contact information for Helps, Prolena and Ahdesa.

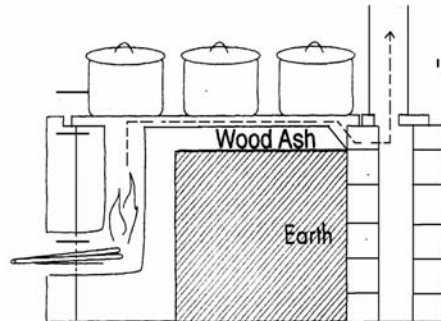

The type of material (cement brick, adobe or metal) that is used for the exterior stove body will not have a great impact on the performance of the stove. Special materials are not needed for the stove body. The stove will function effectively as long as the body of the stove can support 5 pots and can withstand temperatures of up to 500 degrees Fahrenheit.

DIFFERENT STOVES FOR DIFFERENT NEEDS

The Justa type stoves are built using principles that can be adapted to build a stove to suit a particular cooking need. Because one stove design will not work in each community, we offer a number of stove models to choose from:

THE IMPROVED JUSTA STOVE



This stove is the same as the original Justa stove yet it features 2 pots that are submerged directly into the fire flow path. When used with 3 pots it is 50% more efficient than the original Justa.

THE ROCKET STOVE



The single-pot Rocket stove is less expensive and more efficient (25-30%) than the Justa Stove. It is ideal for cooking outside or in areas where a chimney is not needed or available.

THE ROCKET RING STOVE



With the rings in place, multiple pots or tortillas can be cooked at the same time. The rings can also be removed for use with individual round bottom pots.

THE HAYBOX COOKER



The haybox works by retaining heat inside a layer of insulation such as straw, wool or foam. The haybox can reduce fuel consumption by 70% and is simple and inexpensive to build.

For more information about these stoves or if you would like assistance in designing an appropriate stove for your community please contact Aprovecho Research Center

TOOLS AND MATERIALS FOR BUILDING THE JUSTA STOVE

Cooking griddle.
1/8th inch steel cooking griddle. See page 8.

Rocket combustion chamber.
See pages 6 & 7 .

Stove body. 50 (5" by 8") fired clay bricks or 20 adobe blocks. See page 11.

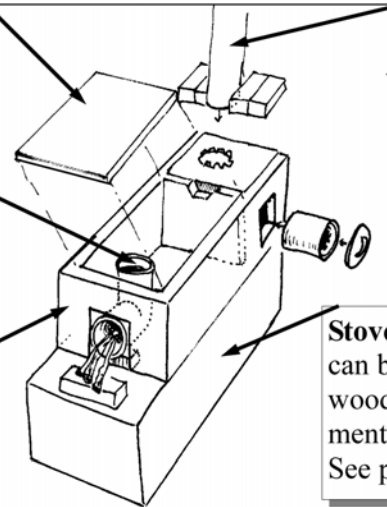

Chimney.
6-20' of 4" diameter chimney pipe. See page 9.

Stove base. This can be made from wood, brick, cement, or adobe. See page 10.

OTHER REQUIRED MATERIALS

- Wood ash, pumice rock, or vermiculite to fill the front half of the stove body (13" by 12" by 14"). Approx. three 5-gallon buckets of insulation
- 2 wheel barrows of clay /sand mortar for constructing the stove body (30% sand/ 70% clay)
- Dry sand or earth to fill rear half of stove body (13" by 12" by 14"). Three 5 gallon buckets
- White clay (for painting outside of stove)
- 4" tin can with plastic or metal lid
- One piece of rolled steel (1/32 by 12" by 16")

TOOLS

- Shovel
- Wheelbarrow
- 3' carpenters level
- Aviation snips
- Hacksaw
- Square
- Hammer
- Trowel

BUILDING THE STOVE BODY

The internal width and length of the stove are the most important. **The internal dimensions will always be 12" wide by 28" long** (assuming you are using the recommended 14" by 30" cooking griddle). These plans are designed for use with 5" bricks . If you are using larger or smaller bricks your external dimensions will change. For example, if you use 6" bricks then the external measurements of the stove will change to 24" by 47".

Use the clay/sand mortar to lay the (pre-soaked) bricks. Use the level and the square when building to be sure that the stove is a uniform shape. Also be careful to maintain the proper dimensions (12" by 28") as you build each brick course

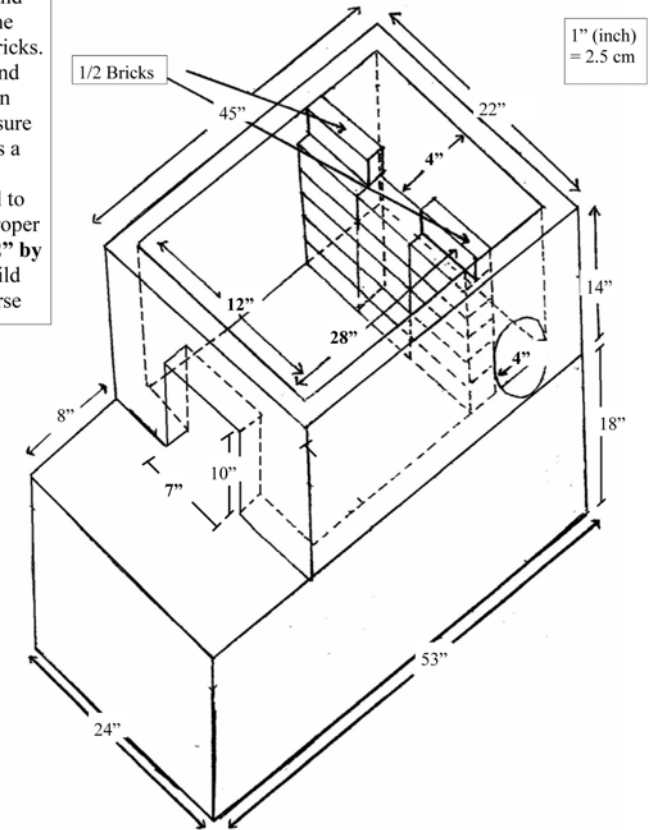

BUILDING THE STOVE BASE

The base for the stove can be built from brick, adobe, cement, wood, or metal. Even better than constructing a new base is to use one from an old, existing stove. The height and length of the base can be altered to suit individual needs. In Latin America and in these plans the base is built 18" high and 24-26" wide (depending on the width of the bricks). See following page for a note on brick width.

For a cement base

2 walls: 10 cement blocks and 1/2 bag of Portland cement.
4 walls: 20 blocks and 1 bag of Portland cement.

For a brick base

2 walls: 35 bricks and 2 wheel barrows of clay/sand mortar.

To minimize the use of materials the stove can be built in a corner of the kitchen so that only 2 walls are needed instead of 4. If you prefer to build it away from the wall just double the amount of materials given for 2 walls. Once constructed the base can be filled with earth or rocks.

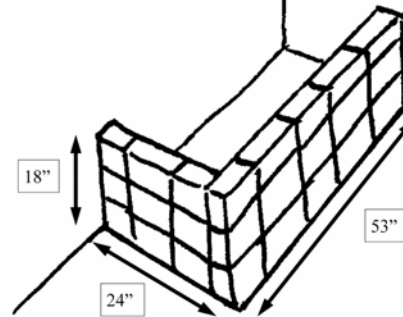

For a wood base.

Construct a wood table that can support 400 lbs.

For an adobe base

2 walls: 20 adobe blocks
 And 1 1/2 wheel barrows of clay/sand mortar.

NOTE: Adobe blocks are the most environmentally friendly option for building the base and the body of the stove because adobe blocks are not fired like clay bricks. The plans use bricks only because, in the USA, and in many parts of Latin America, fired bricks are easier to obtain than adobe blocks.

THE COOKING GRIDDLE

The griddle can be made from rolled steel or cast iron. For rolled steel use no less than 1/8th of an inch thick. This is ideal if you are producing multiple griddles from a 4' by 8' sheet of steel cut the griddles 16" by 32". If you are cutting from a 4' by 10' sheet, cut the griddles 16" by 30". The smaller griddle must be compensated with a smaller stove body (from 12" by 28" to 12" by 26"). The dimensions of the griddle can be elongated (32"- 40") and widened to no more than 20".

One 4' X 8' sheet of rolled steel will produce nine 16" X 32" griddles

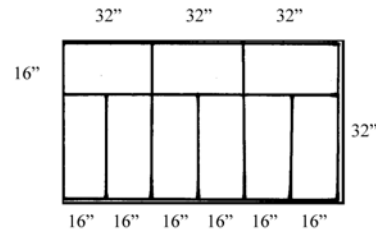

One 4' X 10' sheet of rolled steel will produce twelve 16" X 30" griddles

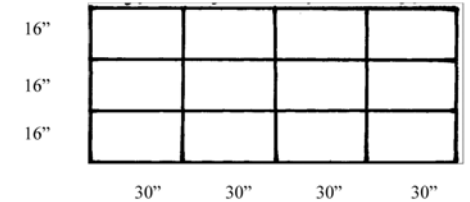

1

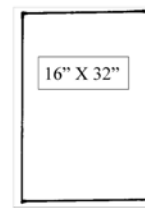

2

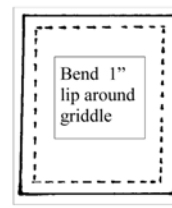

3

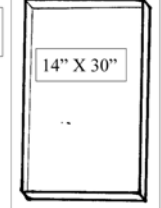

If the griddle begins to warp it is possible to weld 1" by 1/8th" angle iron on the inside of the lips.

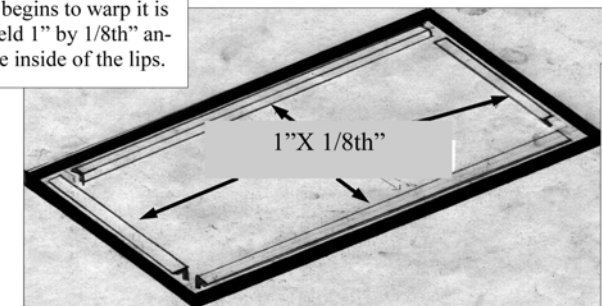

Note: cast iron can be used but should be no more than 1/4" to maintain effective heat transfer.

THE ROCKET COMBUSTION CHAMBER

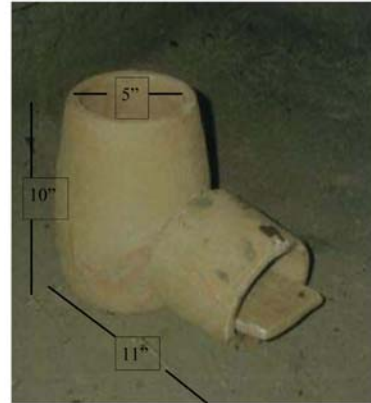

The combustion chamber can be made from refractory cement, refractory ceramic, 1/8th" steel, or cast iron. We are also experimenting with a ceramic tile (see page 7) from Guatemala and our own refractory mix.

In Honduras, a women's cooperative makes a highly durable ceramic combustion chamber that can last up to 10 years. See page 16 for contact information.

Clay pottery often isn't effective but experimentation with local materials can often lead to positive results.

These plans call for an elbow that is 5" in diameter (internal) by 10" tall by 11" long (see photo).

For optimum efficiency, the Rocket stove requires an internal shelf. The shelf should be made from refractory ceramic or 1/4" steel. When in place, the shelf should create a **1" unobstructed gap** between the wood and the bottom of the combustion chamber

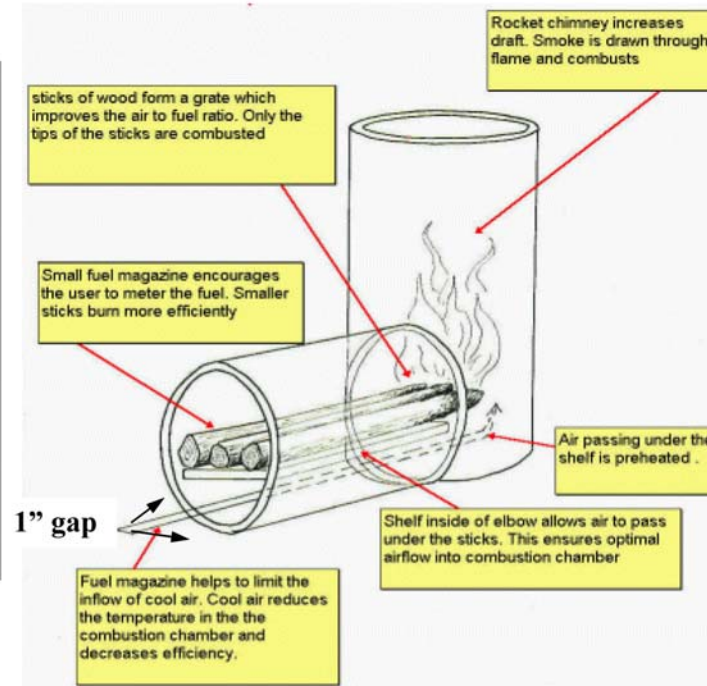

ASSEMBLING THE JUSTA

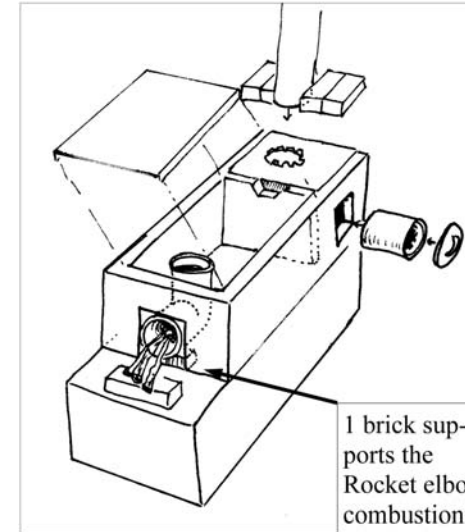

1 brick supports the Rocket elbow combustion chamber.

If possible build the stove body with the Rocket elbow combustion chamber in place. This will allow you to build a strong front wall that fits snugly around the combustion chamber. Otherwise insert the elbow after the stovebody is complete. The mouth of the elbow should be supported by one brick (see photo below). This will raise the elbow 2 inches from the floor of the stove body. This space beneath the elbow should be filled with insulation. The elbow should not be touching the floor of the stove body.



The elbow should be positioned so that the top of the combustion chamber sits 1/2" below the exterior walls of the stove body.

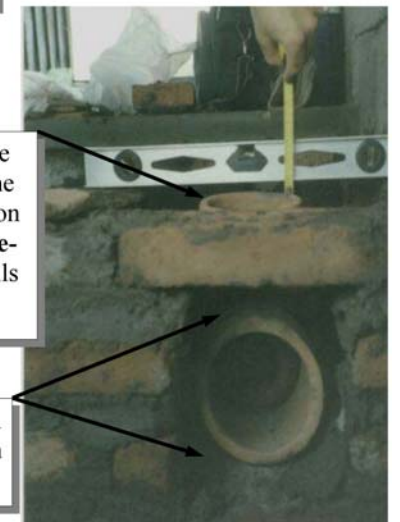

Use the clay/sand mixture to fill the gap between the combustion chamber and the exterior wall.

ASSEMBLING THE JUSTA

Once the elbow is positioned — 2" above the floor of the stove body, 1/2" below the exterior walls, and 3" from the front wall (see photo right) — join the 2 pieces of the elbow together with the same clay/sand mix that was used for mortar.



Fill the stove body with insulation (dry wood ash, vermiculite, or pumice) so that it is level with the exterior wall.

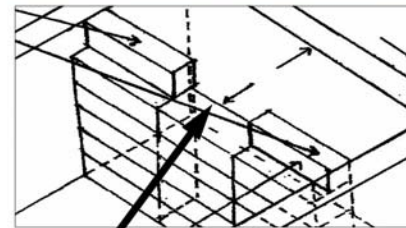

KEEP THIS SPACE UNOBSTRUCTED. DO NOT FILL IN THE GAP OF THE INTERIOR WALL'S LAST BRICK LEVEL

The 1" lip of the griddle creates a 1" passage that allows the hot flue gases to travel above the insulation and below the griddle.

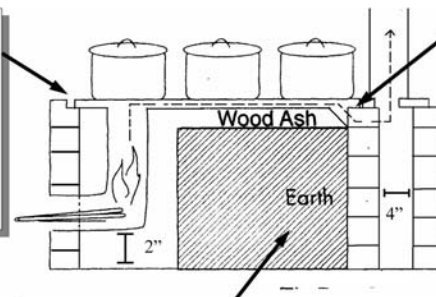

The insulation should begin to slope down 3 inches before it reaches the interior wall. This creates a passage that allows the hot flue gases to exit to the chimney.

If possible, fill the entire stove with insulation. However, if there is a shortage of insulation, the back corner can be filled with dry earth or a mixture of tin cans/dry earth or glass bottles/dry earth.

The Justa stove is for people who make tortillas, have multiple pots, and cook indoors. The Justa:

- Has generated an average fuel savings of 40% in Central America. Savings depend on the efficiency of the previous stove
- Removes 100% of wood smoke from the house and produces 35-85% less green house gases than an open fire.
- Is easy to construct. 2 people can build a Justa in 4-8 hours.
- Is long lasting. In Honduras we are building Justas with a life expectancy of 10 years (not including chimney) for approx \$50.
- Has a high level of acceptance in many Central American communities.

The Justa's chimney, combined with its high combustion efficiency, make it an ideal stove for people who are aware of the health hazards of inhaling wood smoke. However, the Justa stove is not the ideal stove for every cooking situation.

Here are some things to consider before introducing the Justa stove in your community:

Are people cooking outside?

If yes, then consider building an unvented stove outside the house. Unvented stoves can often be more efficient, easier to build and longer lasting. If the chimney is not replaced when it eventually degrades it will expose the family to more smoke than if they had continued to cook outside.

Is Liquid Petroleum Gas (LPG) readily available?

If yes, then consider encouraging a switch to LPG. In many southern countries wood is not sustainably harvested so even an improved wood stove can lead to long term forest degradation. There is some evidence that LPG stoves produces less green house gases than wood stoves.

Are they building conservative open fires?

If yes, consider introducing a hay-box or an unvented stove outside the house. A small, carefully tended open fire can be very efficient. Unfortunately, this type of fire is uncommon in most parts of Central America.

Are they using round bottom pots?

If yes, consider introducing the rocket ring stove or a regular Rocket outside. Round bottom pots will not work with the Justa due to poor contact with the cooking surface. If they have only one pot, consider introducing a Rocket

VIII. Vita

Education

Master of Architecture Spring 2010
Virginia Polytechnic Institute and State University

B.S. Architectural Studies 1995
Washington State University

Experience

Rippeteau Architects Washington, DC
Kishimoto Gordon Dalaya Architects McLean, VA
Mark McInturff Architects Bethesda, MD
Shalom Baranes Architects Washington, DC
Stuart P. White Architects Alexandria, VA
Oudens + Knoop Architects Chevy Chase, MD
Baskervill & Son Architects Richmond, VA
Wm. Henry Harris, III and Associates Architects Richmond, VA
Hamilton Hochheiser Ross Architects Richmond, VA
Robert Shaw Architects Eugene, OR
Soft Tech Design and Construction Eugene, OR