

# Link Establishment in Ad Hoc Networks Using Smart Antennas

**Vikram Dham**

Thesis submitted to the Faculty of the  
Virginia Polytechnic Institute and State University  
in partial fulfillment of the requirements for the degree of

Master of Science  
in  
Electrical Engineering

Dr. Luiz A. DaSilva, Chair

Dr. Scott F. Midkiff

Dr. Annamalai Annamalai

January 15, 2003  
Alexandria, Virginia

Keywords: MAC, WLAN, IEEE 802.11, DSR, smart antenna, simulation

© Copyright 2003, Vikram Dham

# Link Establishment in Ad Hoc Networks Using Smart Antennas

Vikram Dham

## **(Abstract)**

Traditionally medium access control protocols for ad hoc networks have been designed for nodes using omni directional antennas. Through the use of directional antennas, it is possible to obtain higher efficiency. In this thesis we investigate the impact of these antennas on aggregate throughput and end-to-end delay. The use of omni-directional antennas not only results in lower power efficiency, but also decreases network efficiency due to interference caused by the transmission of packets in undesired directions. This thesis explores the effect of using smart antennas and proposes a signaling mechanism for forming the extended links using the network layer. For the performance assessment of the wireless networks using directional antennas, baseline models of phased array antenna and channel have been developed using the discrete event simulator OPNET Modeler™ 8.0. Simulation scenarios have been created for single hop as well as multihop networks. From the results of the simulation we observe that although the nodes forming the extended link experience decrease in end-to-end delay, the data successfully transmitted using extended link is correlated to the spatial distribution of nodes.

## **Acknowledgements**

I would like to thank Dr Luiz DaSilva, my academic and research advisor for his guidance and assistance throughout the project, without which this work wouldn't have been possible. I am highly indebted to him for his infinite patience and understanding. I would also like to thank my committee members, Dr. Scott Midkiff and Dr. Annamalai Annamalai for serving on my committees and for their assistance and support for this thesis.

I would like to thank the Technical Support at OPNET Technologies Inc. and the contributors of the OPNET mailing list for their prompt replies in moments of need.

I am grateful to Kaustubh Phanse for having introduced me to OPNET and for assisting me in developing the modeling skills. I am thankful to Vikash for having provided me with the phased array antenna equations.

I am also very much thankful to Dr. Nicholas Stone for giving me an opportunity to be associated with International Institute for Information Technology.

I wish to thank everyone at Alexandria Research Institute for providing me with a research and thought-provoking environment, especially the participants of Friday network meetings.

# Table of Contents

1. Introduction.....	1
1.1 Motivation.....	1
1.2 Contribution.....	1
1.3 Organization of Thesis.....	2
2. Background.....	3
2.1 The IEEE 802.11 Wireless LAN Standard.....	3
2.1.1 Physical Standard.....	3
2.1.2 Medium Access Control Protocol used by IEEE 802.11.....	4
2.2 Phased Array Antenna .....	5
2.2.1 Examples of Antenna Arrays .....	5
2.2.2 Vector Combination of Signals in Phased Array Antenna .....	7
2.2.3 Beam Forming.....	7
2.3 Directional Antennas for Medium Access Control in Ad Hoc Networks.....	8
2.3.1 Related Work.....	9
2.4 Summary.....	11
3. Simulation Model.....	12
3.1 Introduction.....	12
3.2 Network Modeling Using OPNET .....	12
3.3 Integration of OPNET <sup>TM</sup> and MATLAB <sup>TM</sup> .....	13
3.4 Phased Array Antenna Model.....	16

3.5	Antenna Orientation in Three Dimensional Space.....	17
3.5.1	Antenna Orientation Methodology.....	17
3.6	Receive and Transmit Antenna Process Models.....	19
3.7	Channel Model.....	26
3.8	Antenna Controller .....	28
3.9	Sample Simulation Snapshot .....	29
3.10	Summary.....	30
4.	Link Establishment Using Directional Antenna.....	31
4.1	Location Determination .....	31
4.2	Link Establishment Using Smart Antenna Arrays.....	33
4.3	Signaling Mechanism for Establishing an Extended Link.....	35
4.4	Summary... ..	37
5.	Integration of link Establishing Mechanisms with IEEE 802.11 wireless networks.....	38
5.1	Antenna Time Line Diagram.....	38
5.2	Neighbor Information Base.....	38
5.3	Directional MAC for Basic Access Method.....	39
5.4	Directional MAC Using RTS / CTS.....	40
5.4.1	Directional RTS / Omni-directional CTS .....	40
5.4.2	Directional RTS / Directional CTS .....	42
5.5	Extended Link Establishment Using Dynamic Source Routing Protocol.....	42
5.5.1	General Packet Processing.....	42
5.5.2	Route Discovery .....	44
5.5.3	Route Maintenance .....	45

5.6 Summary.....	45
6. System Model and Simulation Results.....	47
6.1 Channel Model Assumptions.....	47
6.2 Simulation of single hop network scenarios.....	47
6.3 Simulation of multihop network scenarios.....	51
6.3.1 DSR model for nodes using immediate links (node_dsr_omni).....	51
6.3.2 XuDSR model for nodes supporting extended links (node_xudsr).....	52
6.3.3 Simulation Methodology .....	53
6.3.4 Performance Metrics.....	54
6.3.5 Analysis of Extended Link Establishment .....	55
6.4 Summary.....	67
7 Conclusion.....	68
7.1 Conclusion.....	68
7.2 Contribution.....	68
7.3 Future Work.....	69
8 References.....	70
Vitae.....	73

## List of Figures

Figure 2.1: Illustration of an 8-element linear equally spaced antenna array.....	6
Figure 2.2: Illustration of an 8-element equally spaced circular array antenna.....	6
Figure 2.3: Antenna pattern of 7-element uniform equally spaced circular array.....	8
Figure 3.1: OPNET and MATLAB interface .....	14
Figure 3.2: Architecture of the antenna model.....	15
Figure 3.3: Receive antenna attribute table.....	16
Figure 3.4: Illustration of the orientation of the antenna axes with respect to geocentric axes..	18
Figure 3.5 Equation for determining gain of a linear array antenna.....	19
Figure 3.6 Equation for determining gain of a circular array antenna.....	20
Figure 3.7 Antenna controller process model. ....	20
Figure 3.8: Attributes of process “antenna_controller.”.....	21
Figure 3.9 ICI format of command sent to antenna controller.....	22
Figure 3.10 Transmit antenna process model.....	23
Figure 3.11: Receive antenna process model.....	24
Figure 3.12: Null forming process model.....	25
Figure 3.13: Functional architecture of a wireless node using a smart antenna array.....	28
Figure 3.14: Snapshot of a sample simulation scenario.....	30
Figure 4.1: Receiver and transmitter are within range with omni directional antennas.....	34
Figure 4.2: Receiver and transmitter are within range if transmit beam is directed towards the receiver.....	34
Figure 4.3: Receiver and transmitter are within range only if transmit and receive antennas are oriented towards each other.....	35

Figure 5.1: Illustration of antenna time line diagram.....	38
Figure 5.2: Antenna time line diagram illustrating directional MAC for basic access method..	39
Figure 5.3: Antenna time line diagram for Directional RTS / Omni-directional CTS MAC....	41
Figure 5.4: Antenna time line diagram for Directional RTS / Directional CTS.....	42
Figure 5.5: RequestToOrient ( RTO ) packet format.....	43
Figure 5.6: ReplyRequestToOrient ( RRTO ) packet format.....	43
Figure 5.7: XDATA packet format.....	44
Figure 6.1: Node model for nodes using directional medium access control protocol.....	48
Figure 6.2: Distribution of nodes in a square of 600 mts * 600 mts.....	49
Figure 6.3: Throughput of Wireless LANs for Scenarios A, B, C and D.....	50
Figure 6.4: Wireless LAN throughput for different antenna control scenarios.....	51
Figure 6.5: Node model of DSR node using immediate links.....	52
Figure 6.6: Node model for node using xudsr.....	53
Figure 6.7: Spatial distribution of nodes in scenario A .....	55
Figure 6.8: Local end-to-end delay for packets transmitted from node_0 to node_1.....	56
Figure 6.9: Total data successfully transmitted .....	57
Figure 6.10: Data Successfully transmitted from node_0 to node_1.....	58
Figure 6.11: Throughput of node_1.....	59
Figure 6.12: Spatial distribution of nodes in scenario B.....	59
Figure 6.13: End-to-end delay.....	60
Figure 6.14: Throughput of node_1.....	61
Figure 6.15: Total data received by node_1 from node_0 (number of bytes).....	61
Figure 6.16: Total Errors Detected .....	62



Figure 6.17: Spatial distribution of nodes in scenario C .....63

Figure 6.18 ETE delay for Scenario C.....63

Figure 6.19 Data Received by node\_1 from node\_0 (number of bytes).....64

Figure 6.20 Throughput of node\_1.....64

Figure 6.21 End to end delay for varying source inter-arrival times.....65

Figure 6.22 Effect of increasing network traffic on throughput of node\_1... ..66

Figure 6.23 Effect of network traffic on total data successfully received(number of packets)..66

# Chapter 1: Introduction

Ad hoc networks are formed by a collection of wireless nodes without the support of any existing infrastructure. Nodes in an ad hoc network may serve as hosts (end points of communication) or as routers forwarding packets to other hosts. Traditionally, ad hoc networks have been known to use omni-directional antennas for transmission as well as reception. The use of omni-directional antennas may result in lower power efficiency due to interference caused by the transmission of packets in undesired directions. Use of smart antennas in ad hoc networks is envisioned to take advantage of space division multiple access (SDMA) to increase network efficiency by directing the transmitted power in the desired direction. This thesis explores the effect of using smart antennas in ad hoc wireless networks. Since ad hoc networks use a broadcast medium for packet transmission, it is important to observe the effect of smart antennas on medium access control schemes.

## 1.1 Motivation

The current trend is to use omni-directional antennas in ad hoc networks. Various medium access control protocols have been proposed under the assumption that antennas are omni-directional. With the development of smart antennas, the research community has shown interest in integrating them into ad hoc networks to realize the benefits of space division multiple access. If smart antennas can be successfully integrated into wireless networks, this would result not only in an increase in network throughput, but, along with power control mechanisms, a significant power saving in transmitters. Further, the use of smart antennas directs the energy towards a desired direction, thus resulting in an increase in range of packet transmission, effectively decreasing the number of hops in a multihop route network. The use of smart antennas results in formation of time varying links in the network. This demands a complete study of the various links possible and development of a mechanism for establishing those links.

## 1.2 Contribution

The integration of smart antennas into medium access control protocols, which were inherently developed for omni directional antennas, is a non-trivial problem. To this end this

thesis concentrates on different link establishment mechanisms and illustrates typical scenarios using simulations in OPNET.

The main contributions of this thesis are as follows:

- Development of a phased array antenna model
- Development of a methodology to specify orientation of antenna in three dimensional space
- Development of a wireless channel model to realize space division multiple access
- Discussion of the various link establishment mechanisms using smart antennas
- Discussion of the different possible medium access control mechanisms using smart antennas
- Proposal of an extended link establishment mechanism using network layer protocols
- Use of simulations to compare the performance of some of the directional medium access control protocols
- Validation of the extended link establishment mechanism using simulation
- Assessment of the performance of extended links in some typical scenarios

### **1.3 Organization of Thesis**

The thesis is organized as follows. Chapter 2 provides an overview of the research done to incorporate smart antennas in wireless networks. Chapter 3 discusses the baseline antenna and channel models developed in OPNET Modeler 8.0. Chapter 4 focuses on the different links, which can be established using the directional antennas, and highlights the methodologies for determining the location of nodes in the network. Chapter 5 discusses directional medium access control protocols and the extended link establishment mechanism using Dynamic Source Routing (DSR). In Chapter 6 we use the baseline models developed in Chapter 3 along with directional medium access control and routing protocols to simulate single-hop and multihop networks using directional antennas. Chapter 7 puts forth the conclusion and also lays directions for future work in this area.

# Chapter 2: Background

This chapter provides background on two major components of our investigation: wireless local area networks (WLANs) based on the IEEE 802.11 standard and technology for directional transmission and reception of signals through the use of smart antenna arrays. We also summarize related work on data link and network layer effects of using directional antennas in a WLAN environment operating in ad hoc mode and position our work with respect to the existing literature.

## 2.1 The IEEE 802.11 Wireless LAN Standard

After seven years of rigorous draft revisions and competing proposals from different vendors, the final draft of IEEE 802.11 was approved in June 1997 [1]. The wireless standard specifies both the physical layer characteristics as well as link layer protocol for medium access in broadcast channels.

### 2.1.1 Physical Standard

The IEEE 802.11 wireless LAN standard [1] defines the specifications for the physical channel to be used by wireless networks. The specification mainly comprises channel characteristics such as type of modulation, frequency of operation, channel bandwidth and transmission power. The original standard supported the use of either frequency hopping spread spectrum (FHSS) or direct sequence spread spectrum (DSSS). Since the development of the original standards, the specifications have been expanded to allow for higher data rates and the use of a different frequency band. The 802.11b standard was the first to be embraced by industry and it allows the use of frequencies in the range 2.400-2.4835 GHz, which coincides with the frequency of operation of home appliances such as microwave ovens. This allows the operation of the network at data rates of 1 Mbps, 2 Mbps, 5.5 Mbps and 11 Mbps. The standard offers organizations an affordable, fast and easy to integrate wireless LAN solution. The 802.11b 11 Mbps mode is now widely used by organizations to support their applications such as email messaging, file sharing and Internet access. IEEE 802.11b uses carrier sensing multiple access/collision avoidance (CSMA/CA) for medium access control (MAC). The standard can support 11 channels in the available 83.5 MHz band, although typically only three of the non-

overlapping channels are effectively used. In a typical indoor environment, 802.11b can provide coverage up to 400 feet [2]; however, the effective bandwidth available fluctuates as the distance between the wireless nodes increases.

The IEEE 802.11a standard was introduced to provide increased bandwidth. IEEE 802.11a can support data rates up to 54 Mbps and operates at 5 GHz. The gain in bandwidth is obtained by using orthogonal frequency division multiplexing (OFDM) modulation. The two standards, 802.11a and 802.11b are not compatible with each other.

### **2.1.2 Medium Access Control Protocol used by IEEE 802.11 Family of Standards**

According to the IEEE 802.11 medium access control sub layer, the wireless nodes use Carrier Sense Multiple Access along with Collision Avoidance for acquiring the channel. Unlike the medium access control protocols defined for wired networks such as IEEE 802.3, it is not practical for wireless nodes to detect collision when they transmit a frame. After the transmission of a frame, the transmitting node waits for a positive acknowledgment from the receiver to determine whether the intended node successfully received the frame. If the acknowledgment is not received within the stipulated period, the frame is assumed to have been corrupted and is scheduled to be transmitted again.

For collision avoidance, the standard allows the use of either a basic access method or an optional handshake by exchanging Request to Send (RTS) and Clear to Send (CTS) messages. Under the basic access method, a station, when ready for a new data frame transmission, first senses the channel status. If the channel receiver status is found to be idle for at least a duration determined by the DCF Inter Frame Spacing (DIFS) parameter, the station chooses a random number for the back off timer. The random number specifies the number of time slots the transmitter must sense the channel as idle before transmitting the packet. The back off timer continues to decrement while the channel is idle and is stopped if the channel becomes busy some time during the back off period. When the back off timer reaches zero, the data frame is transmitted. This helps in arbitration if numerous nodes attempt to obtain the channel at the same time, because the back off time is selected randomly for all nodes. After transmitting a data frame, the transmitter waits for an acknowledgement (ACK) frame from the receiver for a

period determined by the parameter Short Inter Frame Spacing (SIFS). If the ACK frame is not received within the specified period of time, a binary exponential back off procedure is invoked.

In the RTS / CTS control information exchange, after the back off duration the transmitter sends a Request To Send to the receiver node. The destination node, upon receiving the RTS message, sends a Clear To Send frame after a duration dictated by the SIFS. The CTS effectively reserves the channel for the sender, implicitly notifying all neighboring stations of the upcoming transmission. After the exchange of RTS/CTS control frames the sender begins the transmission of data frames to the destination node after a duration determined by the SIFS. The destination node acknowledges successful data frame transmission by sending an ACK to the source node. For data transmissions involving data packets greater than the maximum allowed data frame size, the source node may continue to transmit packet fragments at intervals of SIFS duration after receiving the ACK. This can continue until the packet is completely transmitted or the node uses the channel for a time duration equal to the dwell time boundary.

## **2.2 Phased Array Antenna**

Phased array antenna systems consist of an array of antenna elements connected by a feeder or adder network arranged so that their individual signals combine to provide maximum gain in one direction while minimizing it in other directions [3]. In case of a transmit antenna, a feeder network is used to feed signals with different phase shifts to each of the elements of the array so that the desired transmit antenna pattern can be obtained. For a receiver antenna, the output of all the antenna elements is phase shifted using pre-determined phase shifts and added in an adder network so as to obtain the desired receiver antenna pattern, which may either maximize or minimize the gain in a particular direction (corresponding to beam steering or null steering, respectively). The gain obtained in the use of phased array antennas is due to the vector addition of received / transmitted signals.

### **2.2.1 Examples of Antenna Arrays**

A phased array antenna system may consist of any number of antenna elements distributed in any pattern [10]. Typically, antenna elements are spaced at regular intervals in a geometrical

pattern such as a linear array, planar array or circular array. An M-element linear array that has

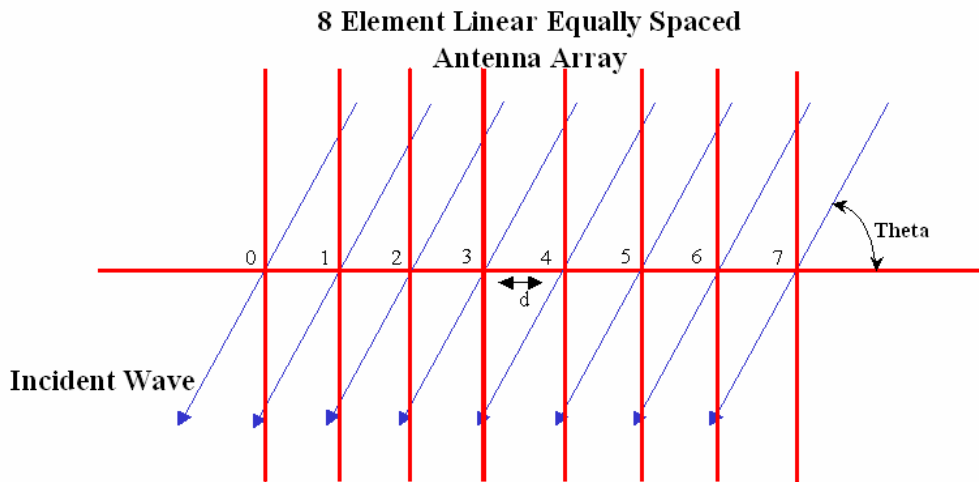

Figure 2.1 Illustration of an 8-element linear equally spaced antenna array.

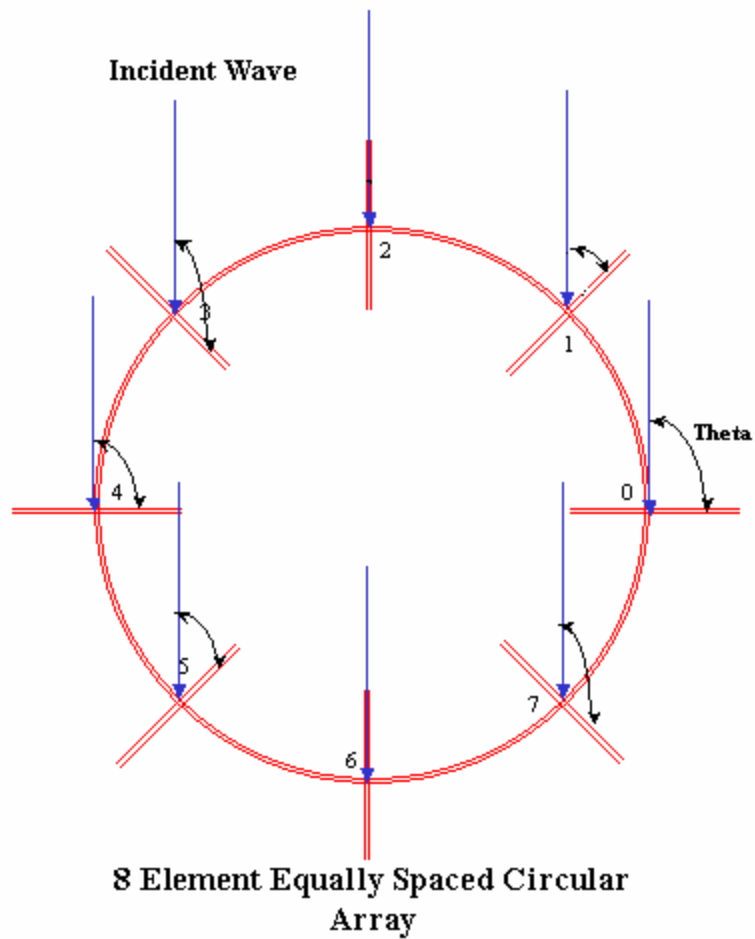

Figure 2.2 Illustration of an 8-element equally spaced circular array antenna.

elements at equal spacing is called a Linear Equally Spaced Array. A Linear Equally Spaced Array in which all elements are fed with signals of equal magnitude is called a Uniform Linear array. An  $M$ -element array that has its elements located at equal spacing on the circumference of a circle and is fed with signals of equal magnitude is called a Uniform Circular Array.

In general, the greater the number of elements comprising the array, the larger its directivity. In Figures 2.1 and 2.2 we illustrate eight-element linear and circular arrays.

### **2.2.2 Vector Combination of Signals in Phased Array Antenna**

A linear array [3] comprises of  $n$  antenna elements each with constant gain  $A$  in the direction of the received signal. The signals incident on each of the antenna element are displaced in phase due to the path difference between the antenna elements. Each of the received signals is amplified and multiplied by a vector quantity referred to as an antenna weight. The signals received after multiplication by the weights serve as inputs to the adder network that combines all signals. Thus, the gain of the antenna array can be varied by varying the spacing between the antenna elements or by varying the value of the weights used to amplify the individual antenna signals.

### **2.2.3 Beam Forming**

Beam forming is a technique in which the gain pattern of an adaptive array is steered to a desired direction through either beam steering or null steering signal processing algorithms. When these algorithms are implemented using a digital signal processor, we refer to them as digital beam forming. This allows the antenna system to focus the maxima of the antenna pattern towards the desired user while minimizing the impact of noise, interference and other effects from undesired users that can degrade signal quality. By using adaptive beam forming algorithms, substantial gain can be achieved (on the order of  $10\log(M)$  dB, where  $M$  is the number of antenna elements) [3] as compared to an omni directional antenna system.

In a multi-user environment, an improvement in performance is observed due to the fact that an adaptive beam forms maxima towards the desired signal and at the same time tries to steer nulls towards the interfering signals, thus reducing co-channel interference. Note that the beam pattern of both the receive and transmit antennas can vary. Therefore, the set of nodes with



which a given node can close a direct link depends on the beam patterns for both transmission and reception. A typical antenna pattern obtained using circular array antenna is shown in Figure 2.3.

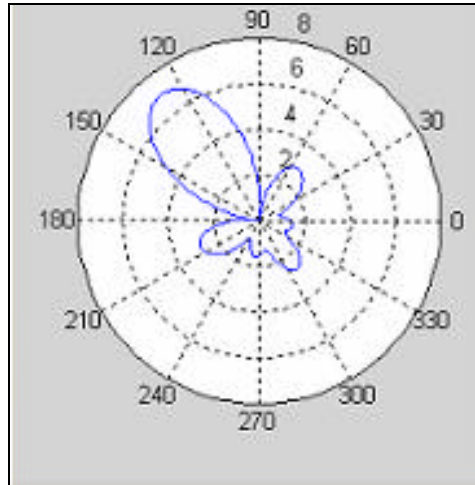

Figure 2.3 Antenna pattern of 7-element uniform equally spaced circular array.

### 2.3 Directional Antennas for Medium Access Control in Ad Hoc Networks

The IEEE 802.11 standard for WLANS has been designed under the assumption that all nodes use omni directional antennas. Most of the research to date has concentrated on developing medium access control protocols under this assumption. With the advances in antenna technology, it is now possible to integrate smart antennas in wireless nodes. However, this requires the development and standardization of a medium access control protocol that is tailored to support the use of smart antennas in the network. Some researchers have looked into the use of directional antennas for ad hoc networks [4, 5, 6,7].

Typically, the use of directional transmit antennas results in higher gain in the desired direction of transmission. Consequently, it may result in increased interference with users lying in this direction. Similarly, the use of a directional receive antenna may result in a node's inability to listen to other transmissions in its vicinity, but outside the direction of the main lobe of the antenna pattern. We observe from this that although the directional antennas have the potential to increase in network throughput due to spatial reuse, whether this benefit is achieved or not

depends on the mechanism used to orient the smart antennas and the location of nodes in the network. In other words, information provided from layers above the physical layer is required to realize the potential benefit from a network perspective.

### **2.3.1 Related Work**

Nasipuri, et al. [4] proposed a directional CSMA/CD mechanism that utilizes a switched beam antenna array and assumes that the gain of the directional antenna is equal to the gain of an omni-directional antenna. The transmitters use omni-directional antennas to transmit RTS frames and the receiver's antennas remain in omni-directional mode. Assuming the receiver is idle, it receives the RTS and transmits a CTS, again using an omni-directional antenna. The transmitter estimates the angle of arrival (AoA) of the CTS being received and transmits data using the directed antenna beam. Since the transmissions and receptions involving omni-directional antenna patterns are susceptible to collisions, this mechanism suffers from high probability of packet error. The authors used a switched beam antenna array that could only switch among a limited number of antenna patterns.

Takai, et al. [6] extended Nasipuri's work [4] by proposing the use of a caching mechanism to store information about angular location of neighboring nodes. This information is obtained from AoA estimation for frames received by each node. Whenever the medium access control layer receives a packet from an upper layer, it would look in the cache to determine whether it has the information about the angular position of the destination node. If the angular position of the destination node is known, the packet is transmitted using the directional antenna after a directional exchange of RTS/CTS control packets. This helps to decrease the dependency on omni-directional antennas. The scheme still reverts to omni-directional mode if angular information is not obtained from the cache.

Choudhury, et al. [5] and Takai, et al. [6] have suggested the use of directional virtual carrier sensing (DVCS), in which a Directional Network Allocation Vector (DNAV) is constructed. The DNAV table stores the angle of arrival of RTS packets along with the duration of data transmission in any given direction. Thus, when the medium access control layer receives a packet from an upper layer, along with the angular profile of the destination node with respect

to the source node, the DNAV table is consulted to determine whether the angle overlaps with any of the ongoing transmissions. If there are no overlaps, the packet is transmitted; otherwise, packet transmission is deferred in accordance with a back off mechanism. In [6] the authors have established the benefits obtained by using DVCS through simulations using QualNet [8]. Both of these studies assume that the signal from arriving packets can be used to infer the spatial location of the source node with respect to the destination node. In [5], the authors also propose a technique for establishing multi-hop links by orienting transmit and receive antennas towards each other. They have used the concept of multi hop RTS to establish such a link and established through simulations that this results in improvement in network throughput. For the propagation of the RTS through multiple nodes, it is assumed that upper layers provide the routing information to the MAC layer.

Most of the analysis and simulations done for characterizing the network performance of nodes using directional antennas are based on the assumption of an ideal antenna pattern having no side lobes which is practically not realizable. In our simulations we used a realistic antenna pattern of a circular array. For the incorporation of the antenna model into practical simulation scenarios we have developed a new antenna orientation approach that can be used by users to specify the orientation of the antenna axis with respect to a geocentric axis. This is necessary to obtain trustworthy results from simulations, which not only should incorporate the constructive contribution of directed beam, but should also be able to take into consideration the effects of side lobes. Besides the development of the antenna model, another challenge has been to incorporate simulation scenarios involving use of directional antennas into OPNET 8.0. OPNET 8.0 uses an abstract channel model, which uses a fixed transmission range as a criterion to determine whether the packet being received is valid or noise. In simulations involving directional antennas we are confronted with spatially varying transmission range of the wireless node depending on the gain of antenna in the direction of transmission. In our customized channel models, received signal strength and signal to interference noise ratio are used as a criteria to determine whether received packet is noise or valid.

Using the developed models, we have built simulation scenarios to characterize the performance of ad hoc networks using realistic adaptive beam forming models and some of the

proposed directional medium access control protocols. After the discussion of the baseline models we illustrate the methodology to establish an extended link using the network layer. Recently we have come across work being done by Choudhury, et al. [5] that is similar to the extended link establishment mechanism we have proposed in this thesis. While Choudhury, et al. assume that RTS is propagated in the network by the MAC layer, our proposal is to use network layer RequestToOrient packets for sending requests for link establishment. For establishing extended links, we propose a basic signaling protocol based on the Dynamic Source Routing (DSR) protocol.

## **2.4 Summary**

The chapter was intended to give the reader a brief overview of the basics of the IEEE 802.11 wireless LAN standard. The discussion of the relevant parts of the standard is followed by a discussion of basic concepts of phased array antennas. We illustrate some commonly used antenna arrays and associated antenna patterns. We also review the current research in the area, focusing on the development of medium access control protocols for ad hoc networks using directional antennas. We describe the contribution of this thesis with respect to the work published to date in this field.

## Chapter 3: Simulation Model

This chapter describes the simulation models we developed to test and evaluate the use of adaptive beam forming in mobile ad hoc networks.

### 3.1 Introduction

The objective of our simulation studies is to characterize some of the proposed directional ad hoc medium access control protocols and analyze the performance gains achieved due to use of space division multiplexing in wireless ad hoc networks. All the simulations for network performance characterization have been performed using the discrete event simulator OPNET Modeler<sup>TM</sup> version 8.0 [9]. OPNET is commonly used for network simulation and provides a rich library of models for implementing wired and wireless simulation scenarios. In this chapter we begin with a brief discussion of the modeling and simulation methodology used in OPNET. The next section discusses the basic methodology for interfacing OPNET and MATLAB<sup>TM</sup>. We integrated MATLAB code into the antenna model to allow the reuse of antenna null and beam forming algorithms previously developed using MATLAB. This is followed by an overview of the design and interface of the phased array antenna model. In Section 3.6 we discuss the modifications performed in the OPNET 8.0 channel model to incorporate space division multiplexing. Section 3.7 illustrates the application of the models by integrating them with a wireless node using the IEEE 802.11 MAC protocol modified to be used with directional antennas. Finally, we present a simulation snapshot from a validation simulation scenario.

### 3.2 Network Modeling Using OPNET

OPNET is among the leading discrete event network simulators used both by the commercial and research communities. It provides a comprehensive framework for modeling wired as well as wireless network scenarios.

Simulation models are organized in a hierarchy consisting of three main levels: the simulation network, node models and process models. The top level refers to the simulation scenario or simulation network. It defines the network layout, the nodes and the configuration of attributes

of the nodes comprising the scenario. The node models are at the second level in the hierarchy and consist of an organized set of modules describing the various functions of the node. The modules in the nodes are implemented using process models, the lowest level in the hierarchy. Process models consist of finite state machines, definitions of model functions, and a process interface that defines the parameters for interfacing with other process models and configuring attributes. Finite state machine models are implemented using Proto C, which is a discrete event library based on C functions. The hierarchical structure of the models, coupled with support for C language programming, allows for easy development of communication or networking models.

OPNET Modeler<sup>TM</sup> uses an object-oriented approach for the development of models and simulation scenarios. The models can be identified as a *CLASS*, which can be reused any number of times in the simulation by creating its different instantiations, just like the creation of objects in any object-oriented programming language. Besides allowing the creation of multiple instances, OPNET allows the user to extend the functionality of the basic models already available as part of the model library. Thus, by defining the value of the attributes of the basic model the user can develop customized models following particular standards or vendor specifications.

### **3.3 Integration of OPNET<sup>TM</sup> and MATLAB<sup>TM</sup>**

OPNET provides a discrete event simulation engine. MATLAB is software for numerical calculations and provides communication engineers with a vast library for implementing communication systems such as channel models and beam forming algorithms. By integrating MATLAB simulation with OPNET we are able to reuse the beam forming algorithms developed in MATLAB and analyze their performance and effect on the upper layers (specifically, data link and network layers) of the communication system. This would be difficult to realize without a discrete event simulator. In this thesis, we have interfaced MATLAB and OPNET so as to reuse the antenna beam steering algorithms, which were developed in MATLAB, and use the graphics library of MATLAB to provide the capability to observe the dynamic changes in the antenna patterns during simulation execution.

For interfacing OPNET and MATLAB, we made use of the MX interface provided by MATLAB, which allows C programs to call functions developed in MATLAB. This is illustrated in Figure 3.1. For calling MATLAB functions the user needs to include following files in the *bind\_shobj\_libs* environment attribute.

1. libmat.lib
2. libeng.lib
3. libmex.lib
4. libmx.lib

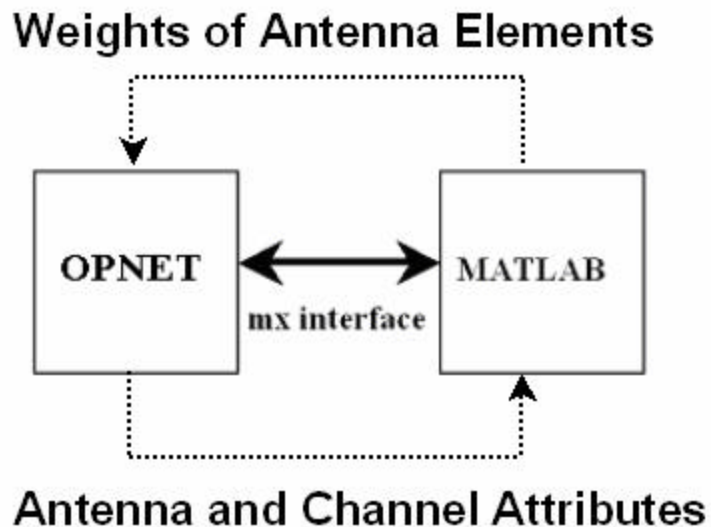

Figure 3.1. OPNET and MATLAB interface.

The directory where the above files are present is included in *bind\_shobj\_flags*. After including the necessary files into the *include* path, the MATLAB engine is started by OPNET simulation at the beginning of the simulation by using the function `engOpen()`. This provides the OPNET simulation with a pointer to a memory location that can be used to pass MATLAB commands to the MATLAB engine. The engine pointer can be shared among different processes by declaring the engine pointer in a header file common to all process models. Variables can be exchanged between OPNET and MATLAB using functions `engPutArray()` and `engGetArray()`.

### 3.4 Phased Array Antenna Model

The block diagram of the antenna model is illustrated in Figure 3.2. The phased array antenna model is implemented using the mathematical equations describing the gain of antenna in terms of azimuth and elevation angles and the vector weights assigned to each element comprising the antenna array. The antenna controller process model receives the antenna control information from the upper layer and determines the antenna gain pattern by varying the magnitude and phase of the antenna element weights. The radio pipeline stages “*dra\_tagain\_fcs\_vt\_adap*” and “*dra\_ragain\_fcs\_vt\_adap*” interface with the antenna controller process model using kernel procedures to determine the value of these weights.

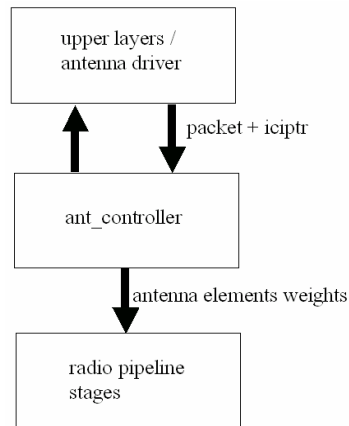

Figure 3.2. Architecture of the antenna model.

The antenna model makes use of interface control information pointers (*iciptr*) to send commands to the antenna controller. The exact format of the *iciptr* pointer and the commands that use this pointer are discussed in Section 3.5. Besides the control information passed from the upper layers to the antenna controller, the model allows the user to specify the antenna structure independently for transmit and receive antennas.



Array Type	Number Of Elements	Delta (meters)	Angle Of Antenna Axis (radians)	Plot	Sample Period (seconds)	Mode
Circular	6	0.15	0.0	True	1.0	AUTO

Figure 3.3. Receive antenna attribute table.

The “Transmit Antenna Attribute” and “Receive Antenna Attribute” of the antenna\_controller process model are discussed next. The attributes for the receive antenna are illustrated in Figure 3.3.

1. *Array Type.* The antenna array can be of either circular or linear type.

2. *Number of Elements.* This is used to specify the number of antenna elements.

3. *Delta / Radius.* This attribute is used to specify the spacing between antenna elements for a linear array or the radius for a circular array. It can take any real value greater than 0. In both cases the antenna elements are distributed such that there is equal distance between all elements.

4. *Angle of Antenna Axis.* This is the angle (in radians) made by the antenna’s x axis with respect to the North Pole. The positive values orient the antenna x axis towards the northeast, while negative values orient the antenna x axis towards the northwest.

5. *Plot.* This attribute can be used to enable the plotting of instantaneous antenna patterns during simulation time. If this is set to True for either the transmit or receive antenna, the gain pattern for that antenna is plotted whenever the beam forming algorithm is invoked. The antenna patterns are plotted as polar plots using MATLAB.

6. *Sample Period*. This attribute is used by a receive antenna only. It specifies how often the channel is sampled in order to adaptively steer the antenna pattern.

7. *Mode*. This attribute is used by a receive antenna only. The mode can take either of two values, AUTO or MAC. If the mode is set to MAC, then the receive beam is formed towards the location of the transmitting entity as provided by the upper layers. If the mode is set to AUTO, then the receive sampler process forms the beam towards the direction from which the strongest signal is being received.

Besides these attributes that can be configured by the user, the antenna\_controller module obtains transmit and receive frequencies from the attributes of the radio receiver and transmitter modules using the internal model access package. These values are required for the calculation of weights for antenna elements.

### **3.5 Antenna Orientation in Three-Dimensional Space**

The antenna model that is part of the standard model library of OPNET 8.0 fails to completely specify the orientation of the antenna pattern with respect to the reference axes used for system specification, hence resulting in the ambiguity in calculation of azimuth and elevation angles made with antenna axis.

In the developed antenna model we have used a novel approach for allowing the user to specify the orientation of antenna with respect to system's frame of reference. The three-dimensional approach adopted employs vector mathematics and can be extended to allow the incorporation of antennas located on mobile nodes.

#### **3.5.1 Antenna Orientation Methodology**

In three-dimensional simulations spanning realistic geographical scenarios, the need arises to use a global frame of reference. In many mobile network scenarios, node location is available in the Global Coordinate System. This provides the information about location of a node in terms of latitude, longitude and altitude. For using the antenna model, the location of nodes is

converted to a geo-centric axis with the earth's center as the origin and the axis oriented as shown in Figure 3.4. The  $i$  and  $j$  axes are along  $(0^\circ \text{ N}, 90^\circ \text{ E})$  and  $(0^\circ \text{ N}, 180^\circ \text{ E})$ , respectively. The  $k$  axis is along the North Pole. As shown in Figure 3.4, the  $i$ ,  $j$ , and  $k$  axes follow the right hand rule. Global coordinates of the node can be converted to geo-centric coordinates using basic conversion equations.

The antenna pattern can be expressed as a function of the azimuth and elevation angles between the antenna axis and the direction of the segment formed between source and destination nodes. The orientation of antenna axis with respect to geo-centric axes must be specified to determine the elevation and azimuth angles. A practical approach to do this is to specify the angle made by the antenna's  $x$  axis with respect to a segment joining the node and the North Pole. This is analogous to specifying the angle made by the antenna axis with respect to the North Pole. In the present model the  $z$  axis of antenna is kept fixed.

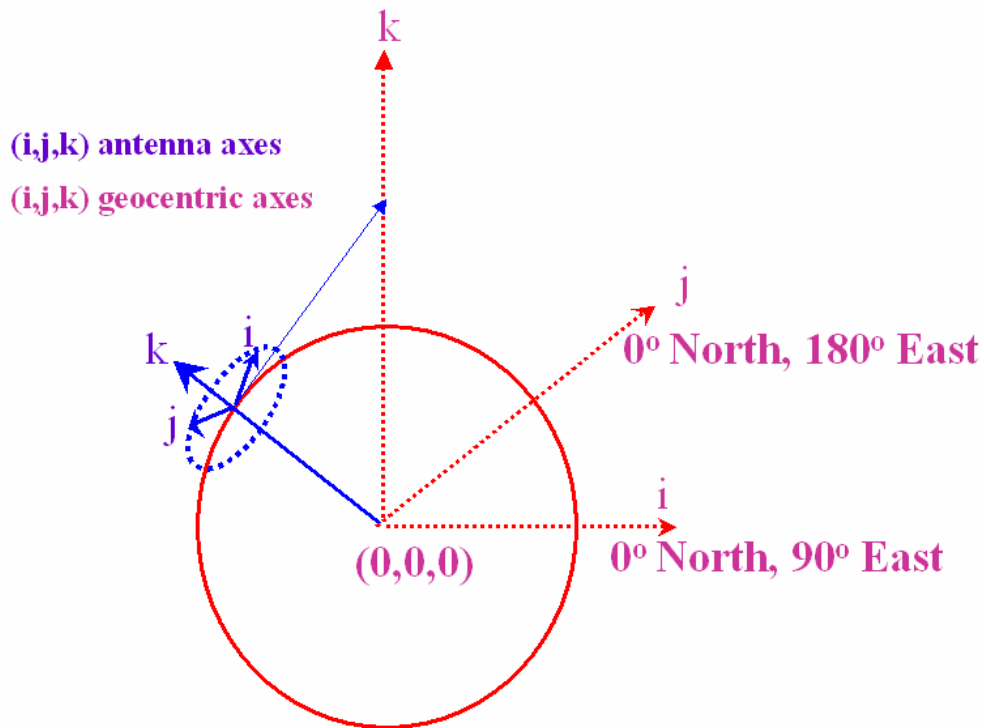

Figure 3.4. Illustration of the orientation of the antenna axes with respect to geocentric axes.

### 3.6 Receive and Transmit Antenna Process Models

OPNET uses “dra\_tagain” and “dra\_ragain” models to determine the value of transmit or receive gain attributes. For adaptive beam forming, the transmit and receive pipeline stages are implemented using “dra\_tagain\_fcs\_vt\_adap” and “dra\_ragain\_fcs\_vt\_adap” models, respectively. In the adaptive antenna model the value of the antenna gain in the direction of transmission is determined using the equations characterizing the antenna behavior. The weights of antenna elements, which are required for the calculation of antenna gain, are obtained from the list stored in the antenna controller process model. The equations used for linear as well as circular array are shown in Figures 3.5 and Figure 3.6.

$$\sum_{i=0, n-1} (\exp(2 * \pi * \text{antenna\_spacing} / \lambda) \cos(\theta) * \sin(\phi) * (1 / w_i))$$

antenna_spacing	Spacing between elements of antenna
$\lambda$	Wavelength of transmitted signal
$\theta$	Azimuth angle
$\phi$	Elevation angle
$w_i$	Complex weight of $i^{\text{th}}$ antenna element
$n$	Total number of antenna elements

Figure 3.5. Equation for determining gain of a linear array antenna.

The azimuth and elevation angles made by vectors joining the source node and transmitting node with respect to the antenna axes are calculated by using three-dimensional vectors as discussed in Section 3.5.

$$\sum_{i=0, n-1} (\exp(2 * \pi * (\text{radius} / \lambda) \cos(\theta - 2 * i * \pi / n) * \sin(\phi)) * (w_i))$$

radius	Radius of circular antenna array
$\lambda$	Wavelength of transmitted signal
$\theta$	Azimuth angle
$\phi$	Elevation angle
n	Total number of antenna elements
$w_i$	Complex weight of $i^{\text{th}}$ antenna element

Figure 3.6. Equation for determining gain of a circular array antenna.

The process model for the antenna controller is shown in Figure 3.7. This process maintains two lists, “*transmit\_weight\_list\_ptr*” and “*receive\_weight\_list\_ptr*,” which are stored as state variables.

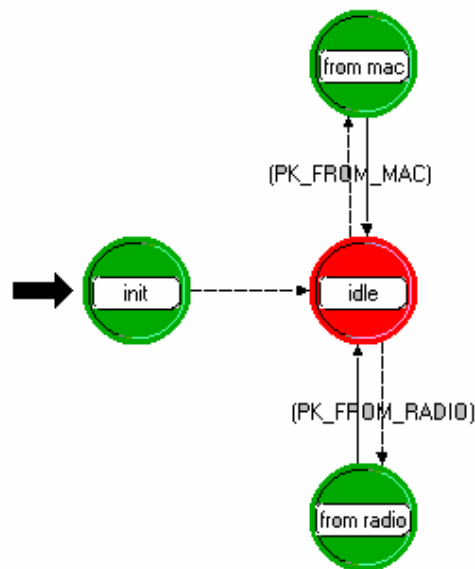

Figure 3.7. Antenna controller process model.

Whenever a command to form either a transmit beam or a receive beam is received from the upper layers, the weights are calculated in accordance to the equations for the antenna type as configured in the attributes of the model.

In the forced state “*init*” the configurations of the transmit and receive antenna type to be used are obtained from the compound attributes of the antenna controller as illustrated in Figure 3.8. The channel attributes such as radio frequency and bandwidth are obtained from the radio module.

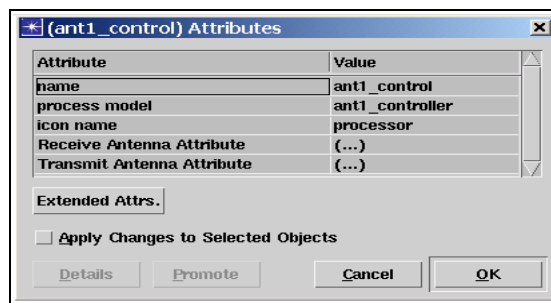

Figure 3.8. Attributes of process “antenna\_controller.”

The process model “antenna\_controller” transitions to state “*from\_mac*” whenever it receives a packet from the medium access control sub layer. The received packet is checked for the presence of Interface Control Information (ICI). If there is no ICI associated with the packet, it is sent to the lower layer for transmission. If the packet is associated with iciptr “antenna\_command,” the fields of the Interface Control Information are extracted and the antenna pattern is changed accordingly. The parameters of the iciptr “antenna\_command” are shown in Figure 3.9.

The screenshot shows a window titled "ICI Editor: antenna\_command" with a menu bar (File, Edit, Windows, Help) and a table of attributes. The table has three columns: Attribute Name, Type, and Default. The attributes listed are: command (integer, 1), format (integer, 0), latitude (double, 0), longitude (double, 0), altitude (double, 0), x (double, 0.0), y (double, 0.0), z (double, 0.0), omni (integer, 0), theta (double, 0.0), phi (double, 0.0), and algorithm (integer, 0).

Attribute Name	Type	Default
command	integer	1
format	integer	0
latitude	double	0
longitude	double	0
altitude	double	0
x	double	0.0
y	double	0.0
z	double	0.0
omni	integer	0
theta	double	0.0
phi	double	0.0
algorithm	integer	0

Figure 3.9 Format of control information sent to antenna controller.

The upper layers must specify the values of these fields. The command field specifies whether the weights should be calculated for transmit or receive antenna. The format field determines the format in which the target information is provided. The target may be specified either in terms of a global coordinate system, geo-centric coordinates or simply in terms of azimuth and elevation angles made with the antenna axis. The algorithm field is used for the receive antenna and determines whether to use beam steering or null steering algorithms. If the omni field is set then an omni-directional antenna pattern is formed.

Once the desired direction of the beam and the algorithm type are determined, the appropriate process for beam forming is invoked. Depending upon the values of command and algorithm fields, one of the following processes is invoked.

1. Transmit Sampler
2. Receive Sampler
3. Null Sampler

The process enters the *“from\_radio”* state whenever it receives a packet from the radio layer. The received packet is then passed on to the upper layers.

The process model for the transmit sampler is shown in Figure 3.10. The transmit sampler is responsible for forming the transmit beam. This process is invoked when the “antenna\_controller” process gets a packet from the MAC layer with a command to form a transmit beam or whenever the antenna controller process is interrupted due to mobility of a target node. This process has three finite states: “*init*,” “*form\_beam*,” and “*idle*.”

The forced state “*init*” is responsible for the initialization of state variables when the process is first invoked. In the unforced state “*form\_beam*,” the weights for the antenna elements are calculated so as to direct the beam in the desired direction. The values of weights are stored in the list “*transmit\_weight\_list\_ptr*.” The process remains in the unforced state “*idle*” until it gets a command for beam forming in a desired direction.

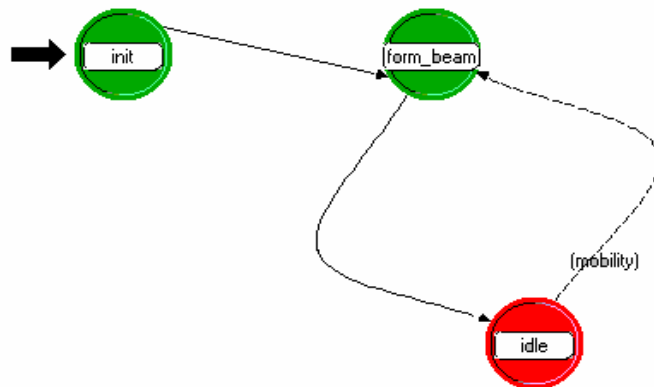

Figure 3.10. Transmit antenna process model.

Thus, at any time during simulation, the “*transmit\_weight\_list\_ptr*” contains the values of weights for transmit antenna elements. At the beginning of simulation, weights of all the antenna elements are initialized to (1,0,0,0...), where number of zeros is equal to one less than the number of antenna elements. This corresponds to an omni-directional pattern.

The receiver sampler, shown in Figure 3.11, increases the sensitivity of the receiver towards a desired signal by steering the maxima (main lobe) of the gain pattern towards the angle of



arrival (AoA) of the signal of interest. The receive sampler model can be configured to either operate in autonomous mode, in which case the receive beam is formed in the direction of the strongest signal received, or it can be configured to form the beam towards a given user as directed by the MAC sub layer. The mode of operation is determined by the mode attribute of the receive antenna. It can either be set to AUTO or MAC. The operation of “receive\_sampler” in either of the modes is described below.

When the mode is set to AUTO the receive sampler process is interrupted whenever there is a change in signal power being received by the antenna. After sampling the received signals the antenna forms the receive beam towards the strongest signal.

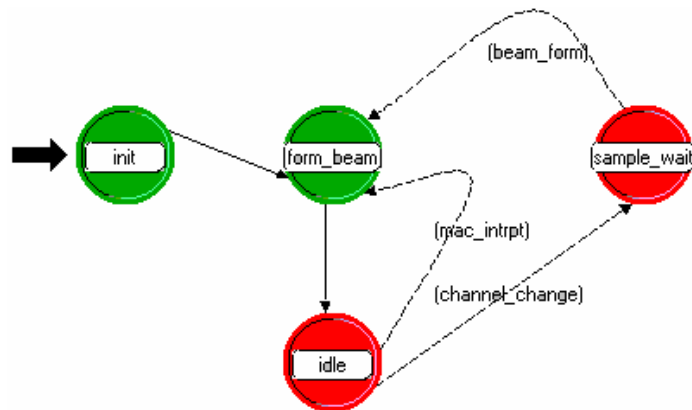

Figure 3.11. Receive antenna process model.

When the mode is set to MAC, the antenna controller process gets a command from the upper layers to form a receive beam towards a given desired user. The target location is explicitly provided by the MAC layer.

As shown in the process model in Figure 3.11, the main states of receive sampler process model are: “*init*,” “*form\_beam*,” “*sample\_wait*,” and “*idle*.”

Forced state “*init*” is responsible for the initialization of state variables when the process is first invoked. In forced state “*form\_beam*” the weights for the antenna elements are calculated

so as to direct the beam in the desired direction. The values of weights used in the antenna beam forming equations are stored in the list “receive\_weight\_list\_ptr.” The process remains in unforced state “*idle*” until it gets a command for beam forming towards a desired direction or there is a change in received signal strength. Unforced state “*sample\_wait*” is entered if the process is running in AUTO mode and stays in this state for a duration equal to the sample period as defined in the antenna attributes.

The null sampler, shown in Figure 3.12, can be used to place a null towards the strongest interferer and maximize the gain towards the desired user(s). The null sampler process is similar to the receive sampler process. Unlike beam steering, for null steering the weights are determined by running iterations of the beam forming algorithms over the set of received signals. The adaptive nulling was implemented using the fast-constrained null steering algorithm described by Elkamchouchi and Elsalam [11]. OPNET calls MATLAB procedure null.m using the MX interface to determine the weights required for null steering.

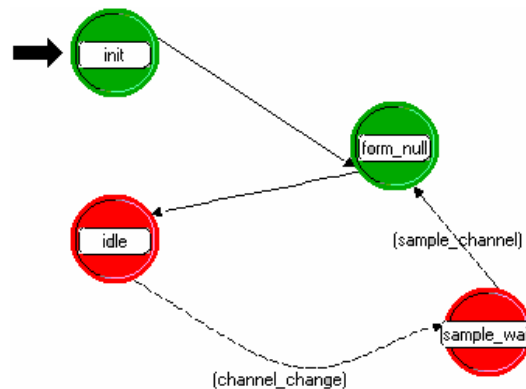

Figure 3.12. Null forming process model.

The null forming algorithm, implemented in MATLAB, is passed the following parameters, which are obtained from the OPNET simulation.

1. Received power of different signals arriving at the receive antenna
2. Angle of arrival of received signals with respect to the receive antenna axis
3. Angle of desired target with respect to the antenna axis

4. Array type (linear or circular)
5. Antenna attributes such as number of antenna elements and spacing between elements

The MATLAB simulation uses the antenna and channel parameters obtained from the OPNET simulation to determine the weights so as to form a beam towards the desired target while forming nulls towards the other users. The weights obtained by the MATLAB simulation are passed back to the OPNET simulation and used to form the receive antenna pattern.

### 3.7 Channel Model

OPNET uses pipeline stages for simulating the various effects of the channel on packet transmission. The baseline wireless pipeline stage “*wlan\_propdel*” provided with OPNET 8.0 uses a predefined range as a criterion to determine whether the packet being received is valid or noise. If the distance between the transmitter and receiver is less than a certain threshold the packet is considered as valid; otherwise the packet is considered to be noise. When the receiver pipeline stages receive a valid packet, a receiver busy statistic interrupt is generated to inform the MAC sub-layer protocol that a packet is being received and the channel is busy.

This mechanism of detecting whether the channel is idle or busy fails to account for path loss and interference from other transmissions occurring in the vicinity of the receiver. For incorporating the phased array antenna into simulation scenarios, we have modified the pipeline stages so as to consider signal to interference and noise ratio (SINR) and signal strength in the receiver pipeline stages to determine whether the channel is busy or idle. The modifications to the pipeline stages are listed below.

1. *wlan\_propdel*. In this pipeline stage transmission data attribute (TDA) *OPC\_TDA\_RA\_MATCH\_STATUS* is set equal to *OPC\_TDA\_RA\_MATCH\_VALID* for all packets. A new TDA attribute *RCV\_FLAG* is defined for all packets and initialized to 0 for all packets.
2. *dra\_snr*. When a packet reaches this pipeline stage the value of *RCV\_FLAG* is obtained. If the value of *RCV\_FLAG* is 0 it means that this is the first time the

“dra\_snr” pipeline stage is being called for this packet. If the value of SINR is greater than the value THRESHOLD, the channel lock is set for this particular channel and statistic interrupt “receiver\_busy” is generated for the antenna controller, which is connected to the “wlan\_mac” process. This allows the generation of the receiver\_busy interrupt only if signal strength or SINR is above a given threshold value. For packets with SINR greater than this value, TDA MATCH and OPC\_TDA\_MATCH\_STATUS are set to OPC\_TDA\_MATCH\_VALID. For the other packets, TDA MATCH and OPC\_TDA\_MATCH\_STATUS are set equal to OPC\_TDA\_MATCH\_NOISE. If the value of RCV\_FLAG is 1, it means that the “dra\_snr” pipeline stage is being called for a packet that is already being received. No calculations are performed for such packets.

3. **wlan\_ecc.** If the value of TDA MATCH for a packet being received in the “wlan\_ecc” pipeline stage is equal to OPC\_TDA\_RA\_MATCH\_VALID, then TDA OPC\_TDA\_PK\_ACCEPT is set equal to OPC\_TRUE, the receiver channel is unlocked and the statistic wire “receiver\_busy” is pulled down.

The developed channel model allows the user to use either signal to interference noise ratio or signal strength to determine the status of received packet.

Besides the modifications in the pipeline stages to incorporate space division multiple access, the antenna controller for each node maintains a list containing information about all the signals being received, their angle of arrival and strength. This list is updated by the “dra\_power” pipeline stage whenever a packet is received by the receiver pipeline stage. The entry is removed when the transmission is completed. This information is used by the receive sampler and null sampler process models to determine the signal strength and angle of arrival for arriving signals and to form beams accordingly.

Thus, by making modifications in the pipeline stages we can realize a more robust channel model for wireless medium access control and obtain the information about received signals needed for adaptive beam forming.

### 3.8 Antenna Controller

The antenna controller forms the transmit and receive antenna beam patterns in accordance with the commands obtained from the MAC sub-layer. While forming the transmit beam the antenna controller needs to know the value of the desired angle of transmission with respect to the antenna axis.

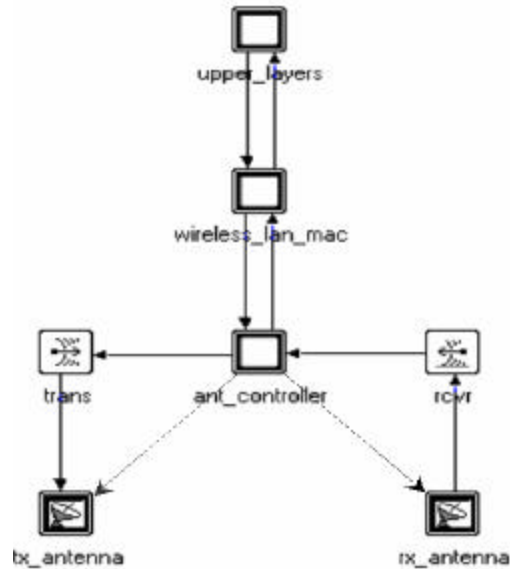

Figure 3.13. Functional model of a wireless node using a smart antenna array.

The receive antenna can operate in two fundamental modes.

- a) *Autonomous Mode*. In this mode the receive antenna tracks the strongest signal and maximizes its receive antenna gain towards the angle of arrival of the strongest signal.
  
- b) *Controlled Mode*. In this mode the antenna controller orients the maxima of the antenna pattern towards the desired direction as determined by the DMAC sublayer. In practical scenarios the medium access control layer or the network layer can determine the desired angle at which the beam should be directed and this is communicated to the antenna controller to form the beam accordingly.

Depending on the medium access control algorithm adopted, the MAC layer determines the beam pattern of receive or transmit antenna or the mode of operation of the receive antenna. When a packet is received, the antenna controller sends the information about signal parameters for the received packet to the MAC layer. These parameters include the time average of the power of the received signal and the angle of arrival of the packet. In Chapter 4 we discuss how this information is used to establish a direct link.

### 3.9 Sample Simulation Snapshot

In Figure 3.14, we illustrate a simulation scenario in which the nodes are using the developed antenna model.

1. `mobile_node_0` is a mobile node and `node_1`, `node_2` and `node_3` are stationary nodes,
2. `mobile_node_0` follows a billiard mobility model within a fixed rectangular region of 1000 meters  $\times$  1000 meters. The position of the `mobile_node_0` is updated at intervals of 5 seconds. The step size is equal to 100 meters and the node continues to move in a fixed direction until hits the boundary of the rectangular region,
3. `node_1` and `node_3` are configured to transmit packets towards `mobile_node_0` at 10-second intervals,
4. `mobile_node_0` is configured to form a beam towards `node_1` and a null towards the other transmitters around it, and
5. `node_2` is configured to form a receive beam towards `node_1`.

The antenna attributes are configured according to the above description and some of the nodes are enabled to plot their antenna patterns during simulation. Before starting the simulation, the animation viewer is started by executing `op_vuanim` in the OPNET console window. At the beginning of simulation, the MATLAB engine is started by OPNET and, thereafter, the antenna patterns are formed in accordance to antenna attributes and commands received from upper layers.

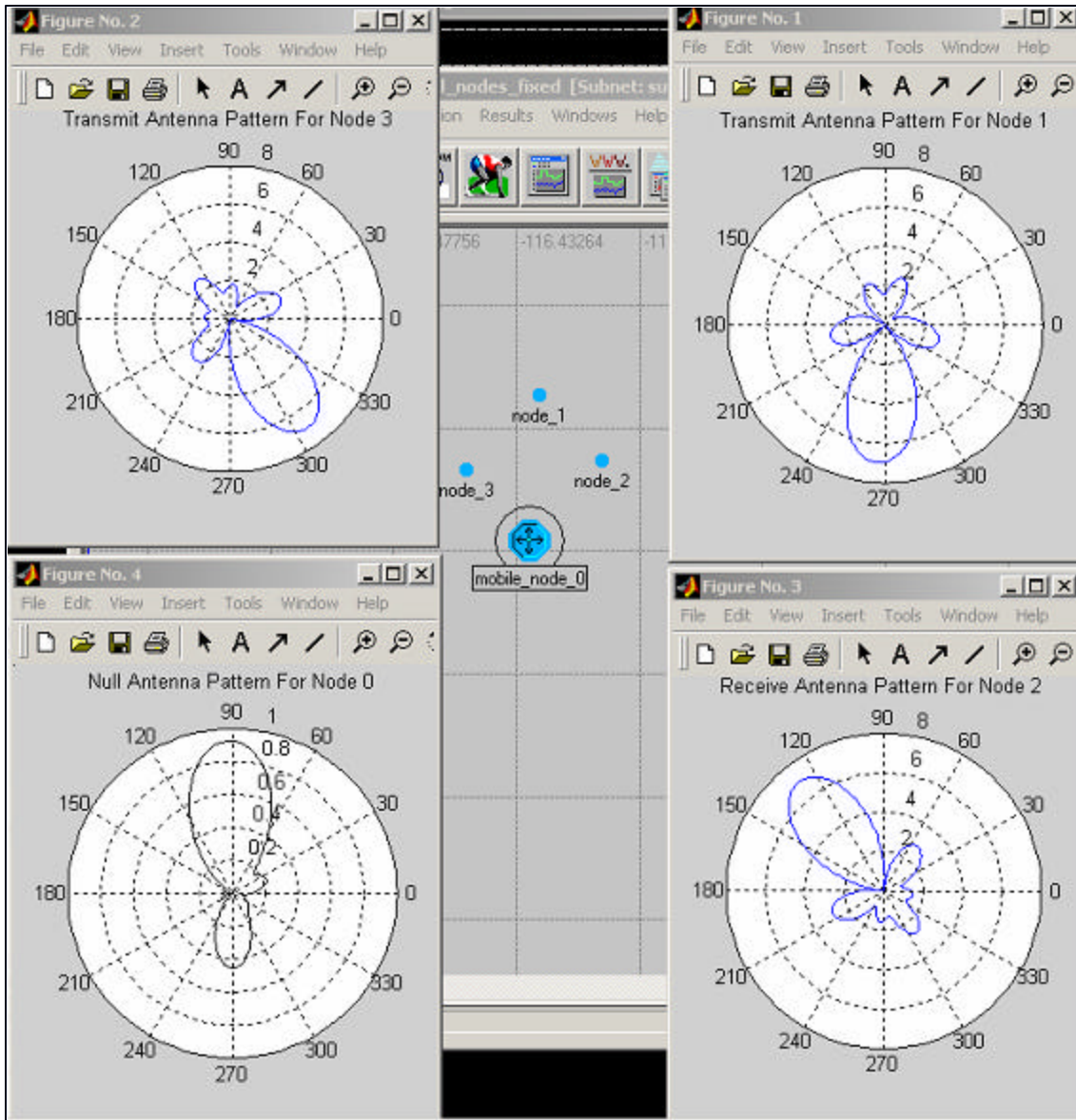

Figure 3.14. Snapshot of a sample simulation scenario.

### 3.10 Summary

This chapter was intended to provide an overview of the methodology used in the development of directional antenna and physical channel models in OPNET. We have presented a fully three-dimensional model for the directional antenna and a mechanism for antenna orientation in three-dimensional space. The physical channel models of OPNET have been considerably modified to provide a more complete platform for wireless simulations involving space division multiplexing. In Chapter 6 we use these models along with the upper layer protocols to assess the performance of wireless nodes using directional antennas and directional medium access control protocols.

## Chapter 4: Link Establishment Using a Directional Antenna

Use of time varying directional antenna patterns is envisioned to help in the establishment of direct links in wireless networks that might otherwise not be possible through the use of omnidirectional antennas. In this chapter, we look at the different links that can be established using directional antennas depending on the location of source and destination nodes. Directional transmission requires *a priori* knowledge of the location of the destination node. In this chapter we discuss some of the location determination methodologies proposed in the literature as well as heuristics for determining the type of link to be established when using directional antennas.

### 4.1 Location Determination

We start by defining the following terms. Two nodes are considered *near neighbors* if they are able to successfully exchange packets in a single hop without the need for both to orient their antennas towards each other. Two nodes are considered *far neighbors* if the successful exchange of packets between them requires the orientation of both transmit and receive antennas towards each other.

The use of directional antennas in wireless networks typically requires some location information about the nodes involved in the communications. Many systems have been developed to solve the problem of location determination in outdoor and indoor environments. Researchers have attempted to use different methodologies and signal characteristics to assist in node location determination. Some examples include the Global Positioning System (GPS) [13], infrared (IR) systems and radio frequency (RF) systems.

GPS is a satellite-based navigation system. The GPS constellation consists of 24 satellites orbiting the Earth every 12 hours. The satellites constantly relay carrier signals, which carry the navigation message. Signals transmitted by the satellites are received by GPS receivers and used to determine the location of the receiver in an earth-centered coordinate system. GPS satellites are maintained by the U.S. Department of Defense and the receivers can be purchased for less than one hundred dollars. Using GPS, the user can determine his or her location anywhere on earth in terms of latitude, longitude and altitude. GPS can provide accuracy on the



order of millimeters under certain circumstances. Despite its advantages, GPS may not be suitable for location discovery in some ad hoc networks as it may be too costly to install in each node. Since the GPS operates in the L band, an additional receive antenna might be required, thus increasing the cost and the size of the equipment. GPS may also impose significant power constraints and will not work in areas where satellite signals cannot be received.

Technologies based on IR and RF have been proposed for location information in areas where GPS cannot be used. The Active Badge [14,15] system was developed to determine the location of persons inside a building. Badges worn by each person emit an IR signal every 10 seconds and sensors placed at known positions in the building detect the signal and notify software agents that process this information. The IR-based system suffers from some major drawbacks such as limited range of operation, lack of support for relaying location information back to the nodes, significant installation costs and poor performance in the presence of sunlight.

Radio frequency based location determination techniques have recently sparked considerable interest in the research community. RF-based location determination techniques exploit the characteristics of the signals transmitted during data exchange, thus avoiding the cost of establishing an additional setup dedicated to location determination. RF-based location determination techniques consider signal characteristics such as time of arrival, signal strength, angle of arrival (AoA) and time difference of arrival. The use of time of arrival involves the stamping of the current time on any outgoing signal by the mobile station. The base station receiving the signal can determine the time taken for packet propagation and, hence, obtain the distance between the mobile and base station. Though conceptually simple, it is difficult to obtain highly accurate estimates of distance due to the problems associated in synchronizing the mobile and base station clocks. The time difference of arrival metric is based on measuring the time difference of arrival of the signal at more than one base station. This eliminates the need for clock synchronization with the base station. The previous two techniques are applicable to infrastructure-based wireless networks (cellular networks in particular). AoA methods [3,16] use phased array antennas to determine the angle of arrival of the signal. If at

least two estimates of AoA at two base stations are available, then the location of the mobile can be determined by triangulation. The drawback of AoA techniques is that for accurate results the received signal must have a strong line-of-sight component. Recently, researchers have suggested the use of signal strength to determine the location of nodes in wireless networks. In the RADAR framework [17], the signal strength at the node from different base stations is recorded by moving the node in a given area, thus generating an empirically-obtained correlation between location and signal strength metrics. The basic assumption in this approach is that signal strength is a strong function of the user's location, i.e., signal strength not significantly affected by fading or other channel impairments.

Finally, location information can be obtained through a combination of the techniques described above and upper layer signaling protocols, such as the exchange of HELLO packets. In this thesis, we assume that wireless nodes can employ one or more of the techniques discussed above to determine the location of other nodes in the network and can use that information to orient their antennas.

#### **4.2 Link Establishment Using Smart Antenna Arrays**

The use of directional antennas for transmission and reception of packets complicates the problem of medium access control, since the range of transmission varies with direction as well as time. Use of directional antennas allows different possible combinations of antenna orientations for link establishment, thus allowing the nodes to communicate over a wider range of distances as compared to the use of constant omni-directional antenna patterns. In this section, we look into how space division multiple access can be employed in wireless networks and illustrate the different types of links possible. For clarity of discussion, we assume all nodes use same type of directional antenna and the transmit power is equal and constant for all the nodes.

While establishing the link, the transmitter and receiver may fall into one of the following scenarios.

1) If the transmitter and the receiver are near neighbors, the link between them can be established by either using an omni-directional or a directional transmit antenna. We call this an *immediate link*. This situation is illustrated in Figures 4.1 and 4.2.

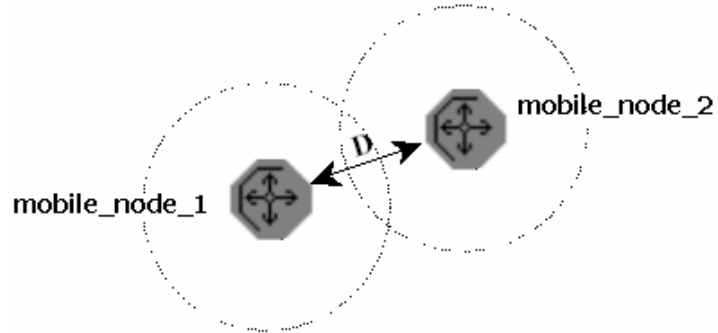

Figure 4.1. Receiver and transmitter are within range with omni-directional antennas.

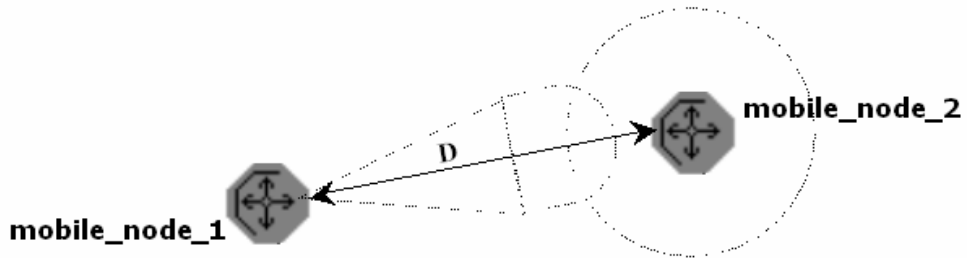

Figure 4.2. Receiver and transmitter are within range if transmit beam is directed towards the receiver.

2) If two nodes are not near neighbors, they may still determine that they are far neighbors. In this scenario data may be exchanged through multiple hops or the source and destination node may establish a direct link between them by orienting their receive and transmit antennas towards each other. We call this an *extended link*. This is illustrated in Figure 4.3.

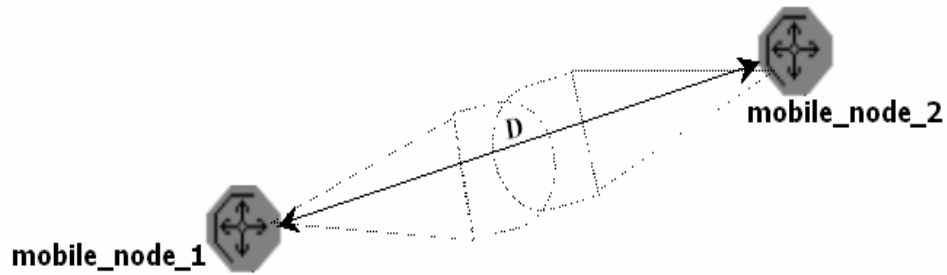

Figure 4.3. Receiver and transmitter are within range only if transmit and receive antennas are oriented towards each other.

The establishment of an extended link requires signaling between the transmitter and receiver nodes through multi-hop paths to allow appropriate orientation of both antennas. The decision to establish an extended link for data transmission, instead of relying on multiple hops, depends on a number of factors, such as delay in establishing the link, feasibility of a directed link and the cost of the link in terms of its effect on aggregate throughput in the network.

### 4.3 Signaling Mechanism for Establishing an Extended Link

For establishing an extended link, antenna orientation information must be exchanged between source and destination nodes. This signaling information must be routed through immediate links. The source and destination nodes can use an established route to send antenna orientation commands.

We demonstrate the basic principle for the orientation of the two antennas by defining a hypothetical network comprising a source node  $S$ , destination node  $D$  and intermediate nodes  $I_1, I_2, \dots, I_n$ . For extended link establishment we introduce three new packet types at the network layer.

***RequestToOrient (RTO)***. This packet is used by source node  $S$  to request the establishment of an extended link with the destination node  $D$  and to send antenna orientation commands to the antenna controller of the destination node. When the network layer receives a packet from the

application layer for transmission, it uses a heuristic algorithm to determine whether to attempt to form an extended link or transmit the packet using a multihop route. If nodes decides to establish an extended link, it creates an RTO packet for the destination, node D, and transmits the data packet using the extended link.

The RTO packet is sent to the MAC layer for transmission just like a normal data packet. The MAC layer transmits the RTO packet to next hop (one of its near neighbors) using an immediate link. Each intermediate node that receives the RTO packet updates the location information for the source node in its location cache and forwards the RTO towards destination node D in accordance with the routing information. The RTO packet is handled at the network layer. When destination node D receives the RTO packet it obtains the location information of the source node from the information contained in RTO packet. In response to the RTO packet a reply packet ReplyRequestToOrient (RRTO) is created and sent from destination node D to source node S acknowledging the request for extended link establishment. RRTO packets are sent through the multiple hops using the immediate links between them. After the MAC layer of the destination node receives an ACK packet for RRTO packet it sent, the antenna controller is sent the commands to orient the receive and transmit antennas towards the Source node S. Thus, the RTO packet serves the dual purpose of providing the destination node with the latest location information of the source node and of sending control information to the antenna controller of the destination node to orient its receive antenna pattern towards the source node.

***ReplyRequestToOrient (RRTO).*** This packet is transmitted by destination node D to source node S after receiving an RTO packet. The RRTO packet contains acknowledgment for the extended link request and provides source node S with destination node D's location information. On receiving RRTO, source node S orients its transmit and receive antenna towards the destination node D, thus closing the extended link.

***ExtendedDataPacket (XDATA)*** After the establishment of the extended link, the data packets that are in queue for destination node D are transmitted through the extended link and marked as type XDATA to prevent the intermediate nodes from learning false routing information or attempting to update their routing tables on the basis of an extended link between source node

S and destination node D. The packets marked as XDATA are sent to the application layer when received by destination node D. The intermediate nodes disregard XDATA packets not addressed to them.

The establishment of extended links can result in decreasing the end-to-end delay between nodes that are far neighbors. Depending on network traffic load and relative positions of other nodes, the extended link may have the effect of increasing or decreasing the overall network throughput, as we demonstrate in Chapter 6. The effective network throughput depends on whether the extended link interferes with the immediate links required by intermediate nodes for data transmission or whether the extended link provides another channel for transmission of packets between the source and destination nodes without interfering with the immediate links. The amount of interference between the extended link and immediate links is a function of the spatial location of nodes in the network and the antenna patterns used for extended link formation.

#### **4.4 Summary**

In this chapter we described the different possible link establishment scenarios using directional antennas. Further we have looked into the mechanism for extended link establishment and suggested the coupling of antenna control packets with location probing packets. This is a basic framework, which could be incorporated into any routing protocol. In the next chapter we present an example of extended link establishment combined with the Dynamic Source Routing protocol for data communications in a mobile ad hoc network.

## Chapter 5: Integration of Link Establishing Mechanisms with IEEE 802.11 Wireless Networks

To realize gains in network performance due to the use of directional antennas, the upper layers must be appropriately integrated with the antenna controller. Past research has resulted in proposal for various directional medium access control mechanisms, each of which defines the antenna beam control mechanism to be used along with the generic IEEE 802.11 wireless LAN MAC. In this chapter we extend some of the proposed directional medium access control mechanisms and integrate them with the Dynamic Source Routing (DSR) routing protocol.

### 5.1 Antenna Time Line

To illustrate the different directional medium access control protocols we make use of timeline diagrams. The antenna time line shows the state of wireless nodes at any time along with the receive and transmit antenna modes of operation. Figure 5.1 illustrates a simple timeline.

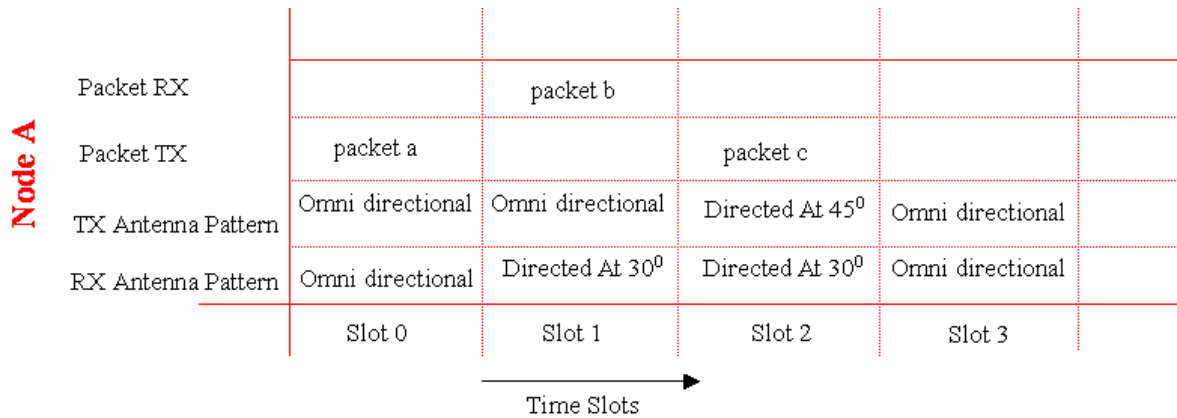

Figure 5.1. Illustration of antenna time line diagram.

At any time slot  $n$  the antenna time line diagram shows the packet being transmitted or received by the node and the orientation of the main lobe of its transmit and receive antenna patterns.

### 5.2 Neighbor Information Base

It is assumed that when a packet is received the radio receiver also obtains the directional information of the transmitting node with respect to the receiving node. This spatial

information can be explicitly contained in the packet or is inferred from the received signal. Thus, the radio module provides the MAC layers with a packet and, also, with the angle of arrival of the packet. A neighbor information table is built using the angle of arrival information and the source address of the received packet. With the passage of time and transmission of packets each node builds a table containing information of angular location of its neighbors. We call this a *Neighbor Information Base (NIB)*.

### 5.3 Directional MAC for the Basic Access Method

In the basic access method, wireless nodes transmit packets if the medium is determined to be idle for a period greater than or equal to the DIFS parameter. Control packets do not precede the data packet transmission. After successfully receiving the packet, the destination node sends an acknowledgment to the source node. We illustrate the operation of the medium access control through an example in Figure 5.2.

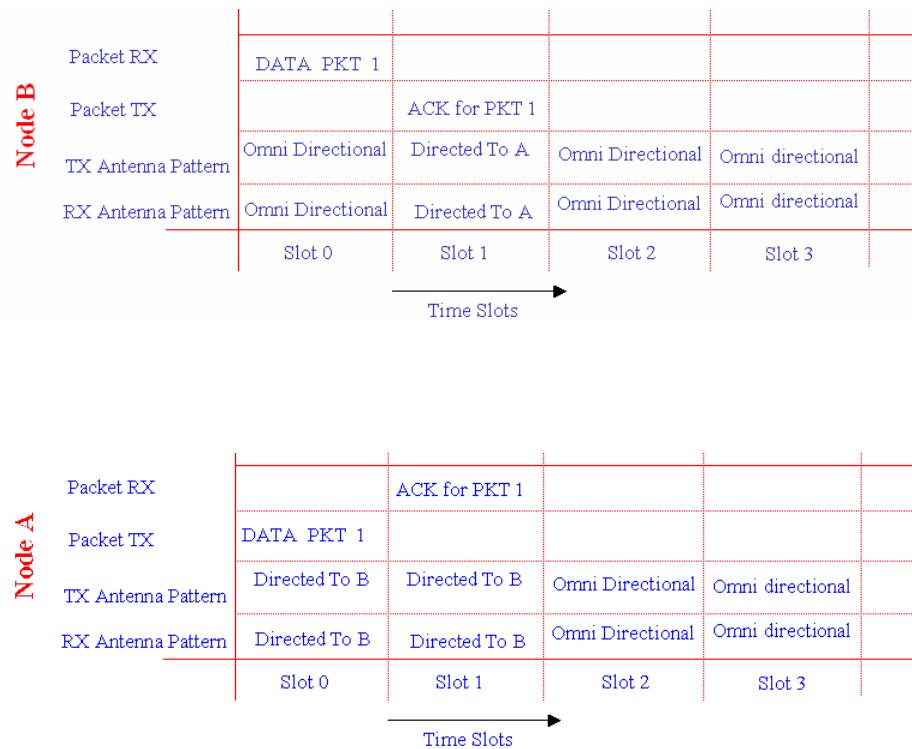

Figure 5.2. Antenna time line illustrating directional MAC for the basic access method.



In the example, node A transmits a frame to node B. The various states that both nodes go through are discussed below.

**Initial state.** Transmit and receive antennas of all nodes are configured to operate in omni directional mode.

**Packet Transmission.** The source uses a table lookup to determine the angle of the destination node. If angular information is obtained, the source orients transmit and receive antennas towards the destination node. If the table does not contain angular information for the destination node, the source forms omni-directional receive and transmit antenna patterns.

**Data Packet Received.** When the destination node receives a data packet it orients its transmit antenna towards the source node and transmits the ACK packet. After the transmission of the ACK the antennas again form omni-directional beams.

#### **5.4 Directional MAC Using RTS/CTS**

In the RTS/CTS method, control frames are exchanged between the source and destination nodes before the transmission of the data packets. The control frames serve two main functions.

1. As in omni-directional scenarios, the use of control packets helps to alleviate the hidden and exposed terminal problems.
2. The use of control packets helps to reduce the probability of collision with data packets.
3. Control frames can be used by the communicating nodes to determine each other's angular location for the orientation of antenna beam patterns.

##### **5.4.1 Directional RTS/Omni-directional CTS**

In this method, the RTS is transmitted using a directional beam, but the CTS is transmitted using an omni-directional pattern. Upon receiving the RTS frame, the destination node obtains the angular location of the source node and orients its receive beam towards the source node. The destination node uses an omni directional antenna pattern for CTS transmission. The antenna time line diagram for packet transmission from Node A to Node B is as shown in

Figure 5.3. In this scenario it is assumed that Node A's NIB has information about Node B's angular location.

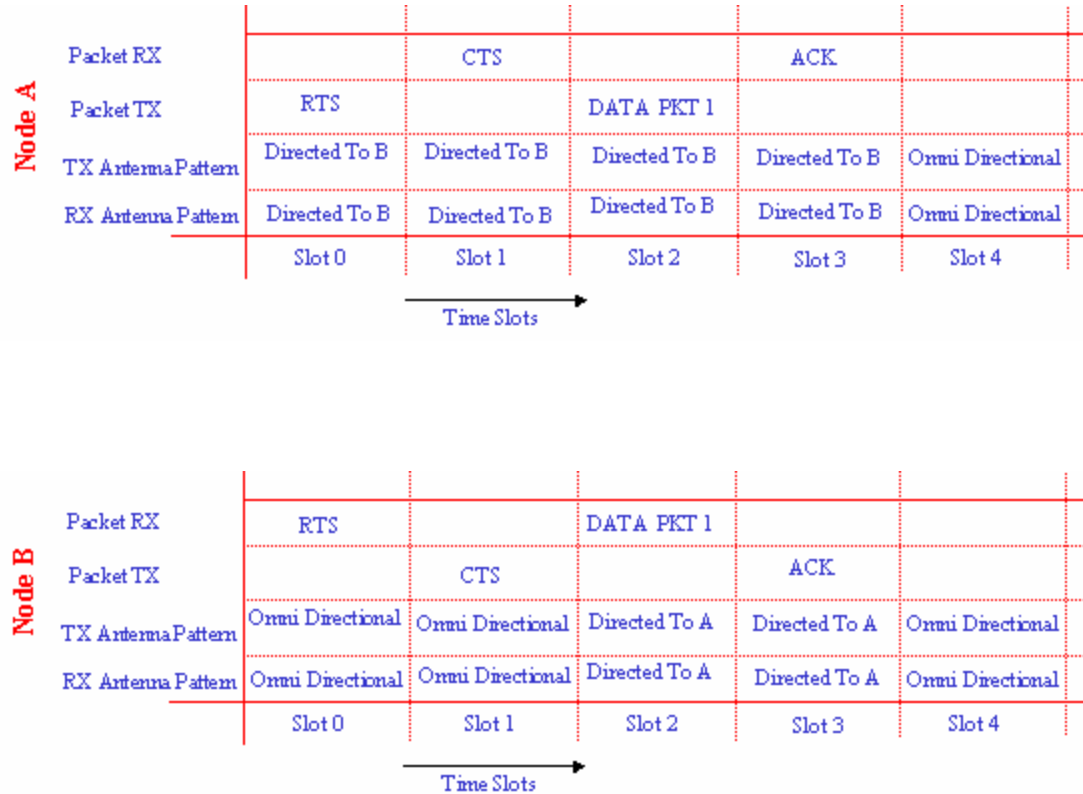

Figure 5.3. Antenna time line for directional RTS/Omni-directional CTS MAC.

#### 5.4.2 Directional RTS/Directional CTS

In this variation of the previously-described algorithm, both RTS and CTS frames are transmitted using a directional beam. The algorithm is illustrated as in Figure 5.4. The receiving antenna pattern is the same as the transmitting antenna pattern.

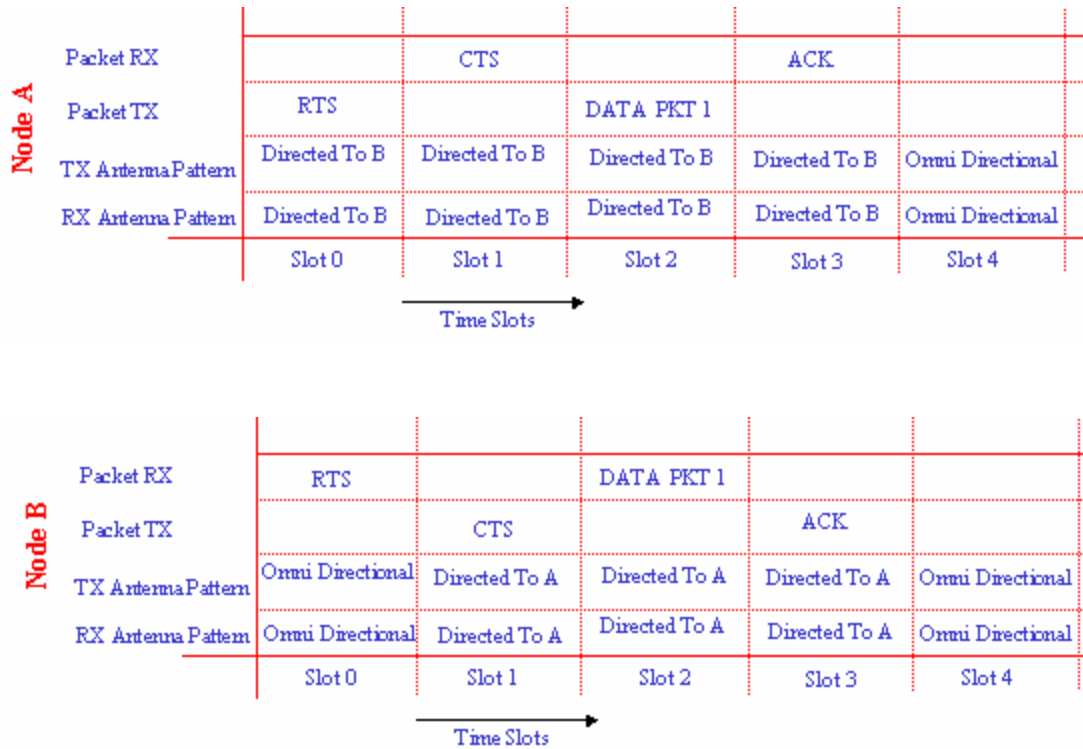

Figure 5.4. Antenna time line for directional RTS/Directional CTS.

## 5.5 Extended Link Establishment Using Dynamic Source Routing Protocol

In the remainder of this chapter, we describe how directional MAC protocols can interact with network layer mechanisms. In particular, we propose *extended link establishment using Dynamic Source Routing*; we call the resulting mechanism *XuDSR*. This mechanism is built using Dynamic Source Routing (DSR) [18,19] protocol.

XuDSR belongs to the class of reactive routing protocols in which the node performs route discovery to the destination node if it does not currently possess routing information in its routing table.

### 5.5.1 General Packet Processing

XuDSR handles the received data packet in the same manner as DSR, unless it receives an indication to form an extended link. Suppose that an extended link is to be established. The packet is processed as follows.

SRC (8 bits)	DEST (8 bits)	RELAY (8 bits)	Seg_Left (8 bits)	Size_Route (8 bits)	Type (8 bits)
Node_0 (8 bits)	Node_1 (8 bits)	Node_2 (8 bits)	Node_3 (8 bits)	Node_4 (8 bits)	Node_5 (8 bits)
Node_6 (8 bits)	Node_7 (8 bits)	latitude (16 bits)		longitude (16 bits)	

Figure 5.5. RequestToOrient (RTO) packet format.

### Route Determination

- If the route to the destination is obtained from the routing table and is greater than one hop, then a RequestToOrient (RTO) packet, as shown in Figure 5.5, is created and sent to the destination node.
  - If the route to the destination is equal to one hop, the data packet is sent without the exchange of RTO packets.
- If the route to the destination is not found in the routing table, a request for a route to the destination node is sent.

### RTO Packet Arrival

- If the packet is addressed to the node, the location table is updated with the location information of the source node obtained from the RTO packet.
- Since the destination node has information about the vectors joining the source and destination, it can determine whether it is possible to establish an extended link between them. If the link is feasible, a ReplyRequestToOrient (RRTO) packet, as shown in Figure 5.6, is created and sent to the source node using the DSR protocol. After the successful transmission of RRTO the receive and transmit antennas are oriented towards the source node.

SRC (8 bits)	DEST (8 bits)	RELAY (8 bits)	Seg_Left (8 bits)	Size_Route (8 bits)	Type (8 bits)
Node_0 (8 bits)	Node_1 (8 bits)	Node_2 (8 bits)	Node_3 (8 bits)	Node_4 (8 bits)	Node_5 (8 bits)
Node_6 (8 bits)	Node_7 (8 bits)	latitude (16 bits)		longitude (16 bits)	

Figure 5.6 ReplyRequestToOrient (RRTO) packet format.

- If the node is just a relay node between the source and destination nodes, the node obtains location information from the RTO packet and updates its location table. The RTO packet is then forwarded to the next hop node.

**RRTO Packet Arrival**

- If the packet is addressed to the node, the location information of the destination node is updated in the location table.
- Since the destination node has information of the vectors joining the source and destination, it can determine whether it is possible to establish an extended link between them. If the link is feasible, controls are sent to antenna controller to orient the antenna receive and transmit beams towards the desired destination. The packets enqueued in the buffer for the destination are sent to the medium access control layer using the XDATA packet format as shown in Figure 5.8. This format is different from the normal DATA packet format of the DSR protocol as it does not require multihop routing information. The fields are defined as follows.
  - The RELAY address is same as the DEST address.
  - Seg\_Left is set equal to 0.
  - Size\_Route is set equal to 1.
  - Type field is set equal to XDATA.

SRC (8 bits)	DEST (8 bits)	RELAY (8 bits)	Seg_Left (8 bits)	Size_Route (8 bits)	Type (8 bits)
data (inherited)					

Figure 5.7 XDATA packet format.

- If the node is just a relay node between the source and destination nodes, the location table is updated with location information of the destination node. The updated RRTO packet is then forwarded to the next hop.

**5.5.2 Route Discovery**

XuDSR uses the same route discovery mechanism as DSR. Whenever the node has a packet for transmission to a destination node whose routing information is not available in the routing

table, route discovery is initiated by broadcasting a NON PROPA REQ. Every node that receives NON PROPA REQ, looks in its routing table for the route to the requested node. If a node determines that it has routing information to the destination node it replies to the requesting node with the routing information. If the node does not have routing information the NON PROPA REQ packet is destroyed and not sent any further. If the source node does not receive a reply it sends a PROPA REQ for the route to the destination node. Unlike the NON PROPA REQ, the PROPA REQ packet is forwarded by intermediate nodes if they do not have the requested routing information in their routing tables. While forwarding the PROPA REQ packet, the node adds its own address in the hop sequence table. This request is propagated in the network until the routing information is found for the destination node or the destination node receives this packet, whereby the node creates a unicast Route Reply (RREP) back to the source of packet and containing the sequence of hops through which this node received the Route Request (RREQ) packet. The RREP packet can also be sent using one of two possible mechanisms. It can either be sent on the route obtained by reversing the sequence of hops contained in the RREQ packet received or it can be piggybacked on a RREQ packet to the source of the routing request. The first approach works well if the links involved are symmetric. In case of symmetrical links, only the second approach can ensure the propagation of the routing information.

### **5.5.3 Route Maintenance**

This is used by nodes to update their routing tables whenever they detect a change in the network topology, for instance due to mobility. Like DSR, XuDSR also assumes that the MAC layer provides it with information about failed links. Whenever an intermediate node detects a link failure it sends a route error packet to the source node. The source node updates its routing table on receiving an error packet and initiates a route request to the destination node.

### **5.6 Summary**

In this chapter we described different methods for link establishment based on the IEEE 802.11 wireless LAN Standard. We have developed XuDSR based on the DSR protocol for extended link establishment and illustrated the signaling and probing functions performed by the control

packets. In Chapter 6 we implement network scenarios using these methods and protocols and characterize their performance.

## Chapter 6: System Model and Simulation Results

This chapter uses the models and the methods presented in earlier chapters to implement simulation scenarios for the assessment of the wireless networks using directional antennas. In Section 6.1 we discuss the assumptions made for channel model in simulations. Section 6.2 presents the system model and simulation results for networks using single-hop packet transmission. This is followed by a discussion of the node & system models used for the simulation of networks using multihop packet transmissions.

### 6.1 Channel Model Assumptions

For the wireless scenarios simulated, it is assumed that all nodes are in line of sight and multi path signals are not present. The packet transmissions are modeled as quanta of energy in channel. The duration for which the packet energy remains in channel is determined by the transmission time and the propagation time of the packet. Signal to interference noise ratio is used to determine the packet status as discussed in Section 3.7. The BER is obtained by using the BPSK modulation curves. The path loss is calculated using the Hata-Okumara equations [20, 21]. The range of nodes while using omni-directional antennas and transmitter power of 1 mw is approximately 350 meters.

### 6.2 Simulation of Single-Hop Network Scenarios

For the comparison of wireless LAN medium access control protocols using directional antennas we erected system models that allow for single-hop packet transmissions. The node models were built using the baseline directional antenna model and the modified wireless LAN models. The following medium access control protocols have been implemented.

**Scenario A.** In this scenario all the nodes use omni-directional antennas for transmitting and receiving the packets.

**Scenario B.** In this scenario directional antennas are used for transmitting the Request To Send (RTS), Data and Acknowledgment (ACK) packets, while omni-directional antennas are used for transmitting the Clear To Send (CTS) packet.



**Scenario C.** In this scenario directional antennas are used for transmitting RTS, DATA, CTS and ACK packets.

**Scenario D.** In this scenario Data is transmitted using the basic access method by directing the transmit antenna towards the desired user. The receiver operates in the omnidirectional mode.

The model of the wireless nodes is shown in Figure 6.1. The node model consists of the medium access control module *wireless\_lan\_mac* interfacing with antenna controller *ant1\_control* using the *ici\_ptr*. The process model “*wireless\_lan\_mac*” is modified to generate commands for the antenna controller in accordance with the beam control algorithm. The antenna controller varies the receive and transmit pattern in accordance with the commands received from the medium access control sub-layer. For the network characterization we have used an equally spaced seven-element circular array. The radius of the circular array is 0.15 meters. The nodes are located in area of 600 meters  $\times$  600 meters as shown in Figure 6.2.

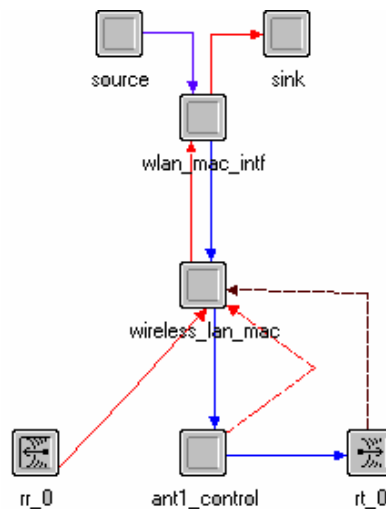

Figure 6.1. Node model for nodes using directional medium access control protocol.

The wireless nodes obtain the angle of arrival from the antenna controller and maintain a Neighbor Information Base that contains information about the angular position of neighboring

nodes. In the present simulation, packets are generated for the neighboring nodes using uniformly distributed (0.0001,0.001) inter arrival times and a constant packet size of 1024 bits. As seen in Figure 6.3, there is a performance improvement for scenarios involving use of directional antennas. The performance gain is greatest for the method that uses directional RTS/CTS. Figure 6.4 compares the throughput of the different directional medium access control protocols over a range of inter-arrival times. The interarrival time is varied from (0.0001, 0.001) to (0.0006, 0.006) at discrete steps of (0.0001, 0.001).

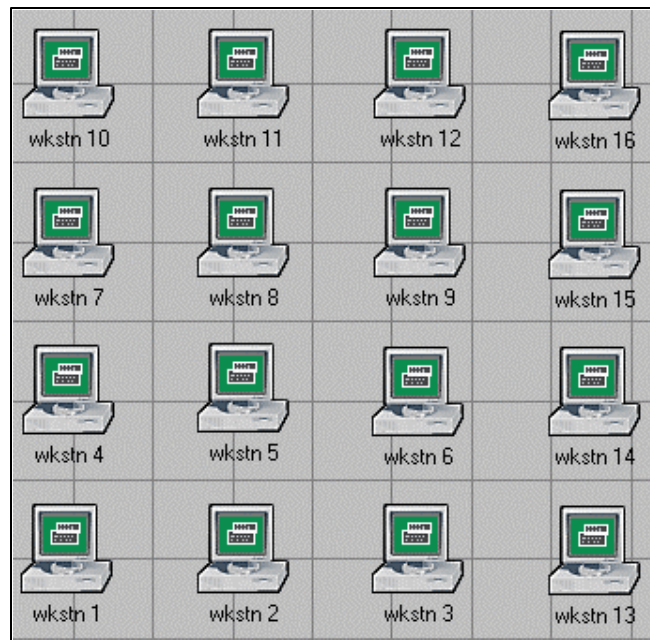

Figure 6.2. Distribution of nodes in a square of 600 meters  $\times$  600 meters

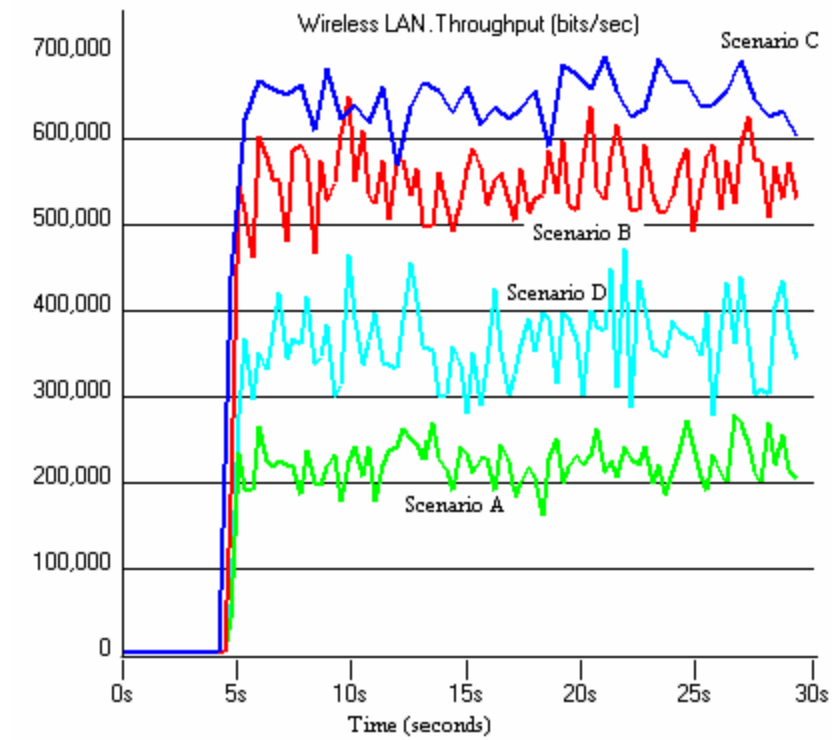

Figure 6.3. Throughput of wireless LANs for scenarios A, B, C and D.

The plots of throughput in Figures 6.3 and 6.4 validate the argument that the throughput of the network depends on the antenna control algorithm used. The use of directional RTS/directional CTS provides better performance than using directional RTS/omni-directional CTS.

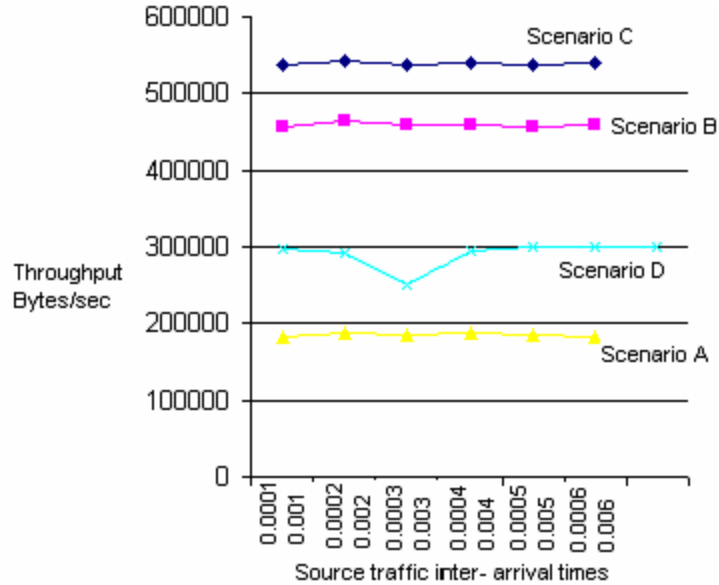

Figure 6.4. Wireless LAN throughput for different antenna control scenarios.

### 6.3 Simulation of Multihop Network Scenarios

Network scenarios involving multihop packet transmissions were created to investigate the effect of extended link formation on the upper layer. For multihop scenarios, the Dynamic Source Routing protocol is used for routing.

#### 6.3.1 DSR model for Nodes Using Immediate Links (node\_dsr\_omni)

We developed this node model for simulating the network scenarios that involve wireless transmissions using the immediate links as discussed in Chapter 5. The node model is shown in Figure 6.5.

The node model consists of a DSR routing process model that interfaces with the upper layer, as well as medium access control interface module. The DSR routing process model has been obtained from [22]. The DSR module receives the packets from the source module and processes them in accordance with the DSR protocol. The packets that are to be transmitted to the medium access control layer are sent to the *wlan\_mac\_intf* module. The *wlan\_mac\_intf* module maps the network layer address to a medium access control layer address and passes this information, along with the packet to the *wlan\_mac* layer for transmission. The *wlan\_mac*

process model uses the basic access method for medium access control. The node model is configured to form omni-directional receive and transmit antenna patterns throughout the simulation.

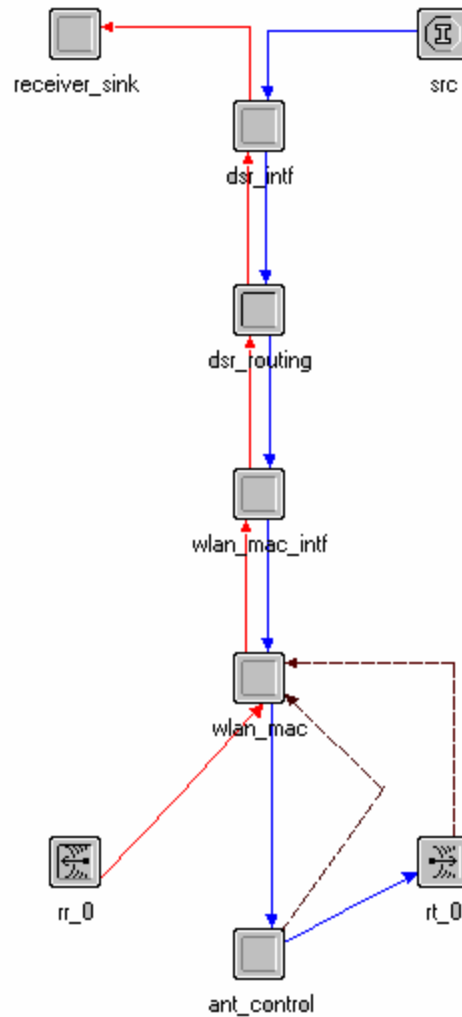

Figure 6.5. Node model of DSR node using immediate links.

### 6.3.2 XuDSR Model for Nodes Supporting Extended Links (*node\_xudsr*)

The XuDSR node model is built to support the extended link formation. The node model consists of the traffic source module, the XuDSR module, the wireless medium access control module and the antenna controller module. The XuDSR module is obtained by modifying the DSR process model from [21] to support extended link establishment. Packet handling for

XuDSR RequestToOrient, ReplyRequestToOrient and XDATA packets is introduced in the DSR process model in accordance with the XuDSR mechanism discussed in Chapter 5.

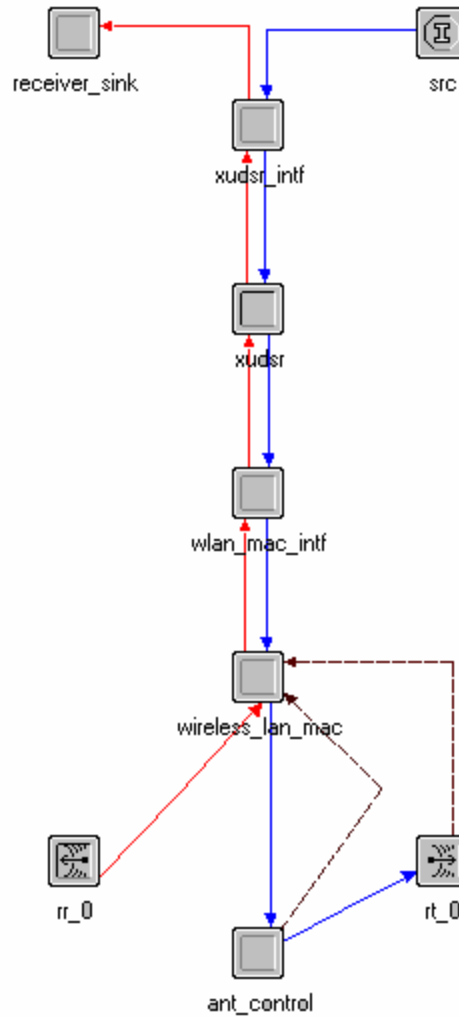

Figure 6.6. Node model for node using XuDSR.

The directional antenna array used in simulations is a seven-element equally spaced circular array.

### 6.3.3 Simulation Methodology

The results of simulations using directional antennas depend on the spatial location of nodes in the network. Scenarios are simulated using the two different node models discussed earlier.

Thus, for each network topology and fixed set of traffic characteristic, we have the following two simulation scenarios.

1. Scenario containing omni-directional DSR nodes. This scenario uses the *node\_dsr\_omni* node model. We call this the omni-directional scenario.
2. Scenario containing XuDSR nodes. This scenario consists of nodes using the XuDSR routing protocol along with the directional basic access method. We call this the extended scenario. For analysis, we configured nodes *node\_1* and *node\_2* to establish an extended link between them. All other nodes use immediate link for data transmission.

The nodes are randomly distributed in a given physical area and simulations are run for a fixed set of traffic characteristics. In all simulation scenarios *node\_0* generates traffic for *node\_1* using a uniformly distributed inter arrival time. All other nodes generate packets addressed to each other using randomly selected destination address. The traffic in simulations is started at  $t = 2$  seconds. The simulations are stopped when the throughput of *node\_1* reaches a steady state value. The simulation is assumed to reach steady state when the 95% confidence interval is within 1% of the average value. The simulations were run for 50 seconds for Scenario A and 4 minutes for Scenarios B and C. For characterizing the effect of network traffic on *node\_1* throughput, Scenario C is simulated by varying the traffic profile of nodes in network. Each simulation is run for five different seed values. These simulations are performed for the networks using the extended link as well as omni-directional links and for five different traffic profiles. Since the simulation results are correlated to the spatial distribution of nodes, a snapshot of network topology is maintained for each set of simulation results.

#### **6.3.4 Performance Metrics**

The following performance metrics are collected from the different simulation scenarios.

1. End-to-End (ETE) Delay. This statistic is used to determine the time difference between the generation of packet in *node\_0* and the arrival of the packet at the upper

- layer in node\_1. The end to end delay statistic is collected for the packet transmissions between node\_1 and node\_0.
2. Local Data Received. This statistic is used to determine the amount of data received by node\_1 at any time during the simulation.
  3. Total Data Successfully Received. This statistic measures the total number of packets successfully received by all the nodes in the network.
  4. Throughput of node\_1. This statistic measures the effective throughput available between nodes node\_0 and node\_1.

### 6.3.5 Analysis of Extended Link Establishment

For the performance analysis of network scenarios using extended links, we present the network topologies and performance results for the scenarios simulated using OPNET. We begin with an idealistic scenario for illustrating the performance gain using extended links. Figure 6.7 shows a network scenario consisting of nodes distributed in the network so as to form a “U” shape. Simulations are run for this scenario using the node\_dsr\_omni and node\_xudsr node models.

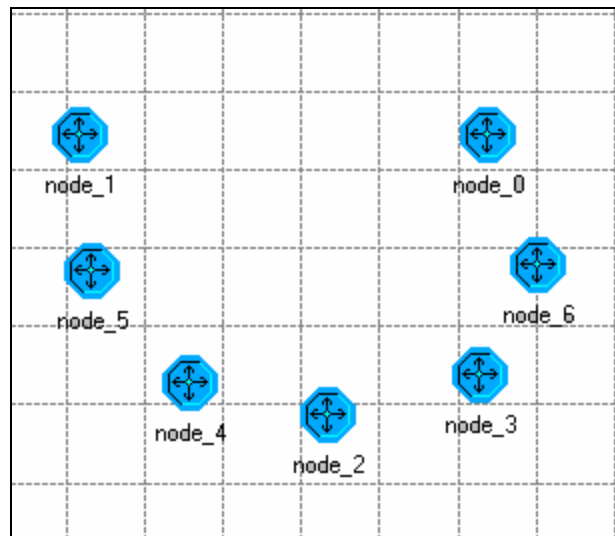

Figure 6.7. Spatial distribution of nodes in scenario A.



In the simulation scenario using node\_dsr\_omni node models, the packets from node\_0 to node\_1 are transmitted through the multihop link node\_0→ node\_6→ node\_3→node\_2→node\_4→node\_5→node\_1. In the simulation scenario using node\_xudsr, node\_0 establishes an extended link with node\_1 instead of sending data packets using the multihop route. The simulations for both scenarios are run using the same traffic profile as indicated in Section 6.2.3. The simulation is run for 40 seconds, as this time is sufficient to observe steady-state metric values.

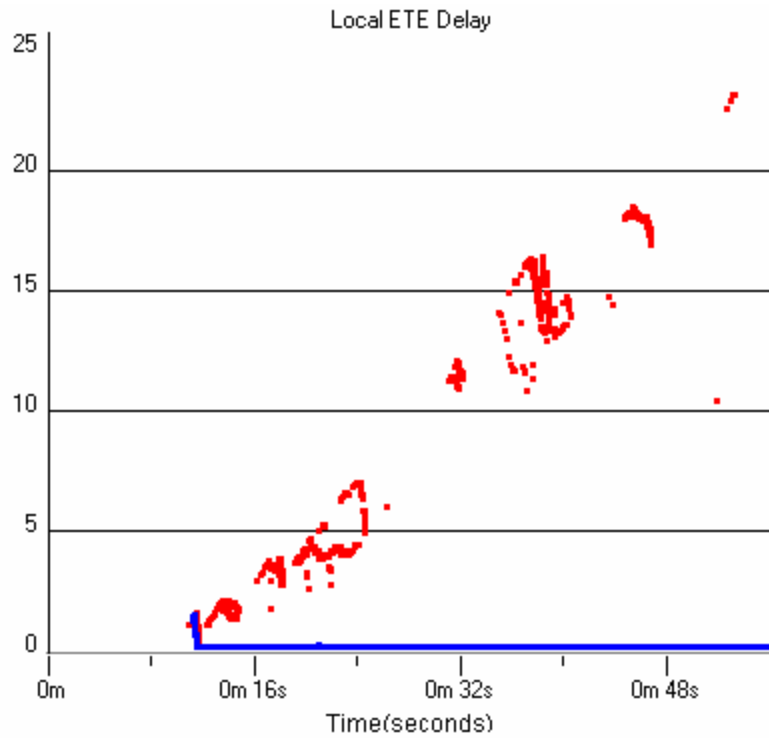

Figure 6.8. End-to-end delay for packets transmitted from node\_0 to node\_1.

The plots for local end-to-end delay, total packets successfully transmitted in the network and local data successfully received for packets transmitted between node\_1 and node\_0 are shown in Figure 6.8, Figure 6.9 and Figure 6.10, respectively.

As seen from Figure 6.8, the use of the extended link in network A shown in Figure 6.7, leads to decrease in the end-to-end delay for packets transmitted between node\_0 and node\_1. The improvement is obtained because the extended link forms a non-interfering wireless link between node\_0 and node\_1, which is parallel to the link formed by other nodes transmitting

packets in the network. The plots shown in Figure 6.9 and Figure 6.10 demonstrate the improvement in data received with the use of extended link.

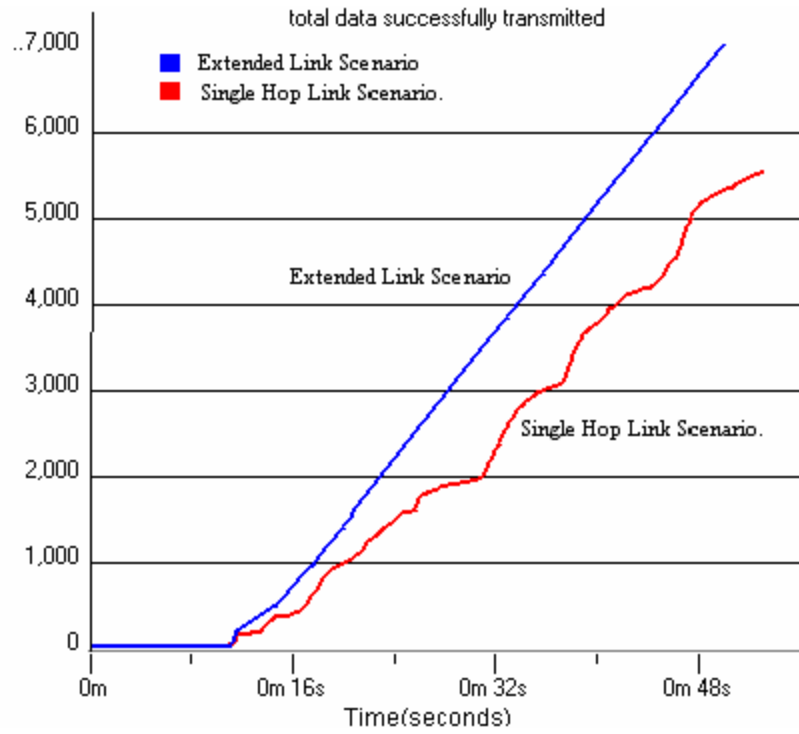

Figure 6.9. Total data successfully transmitted (number of packets).

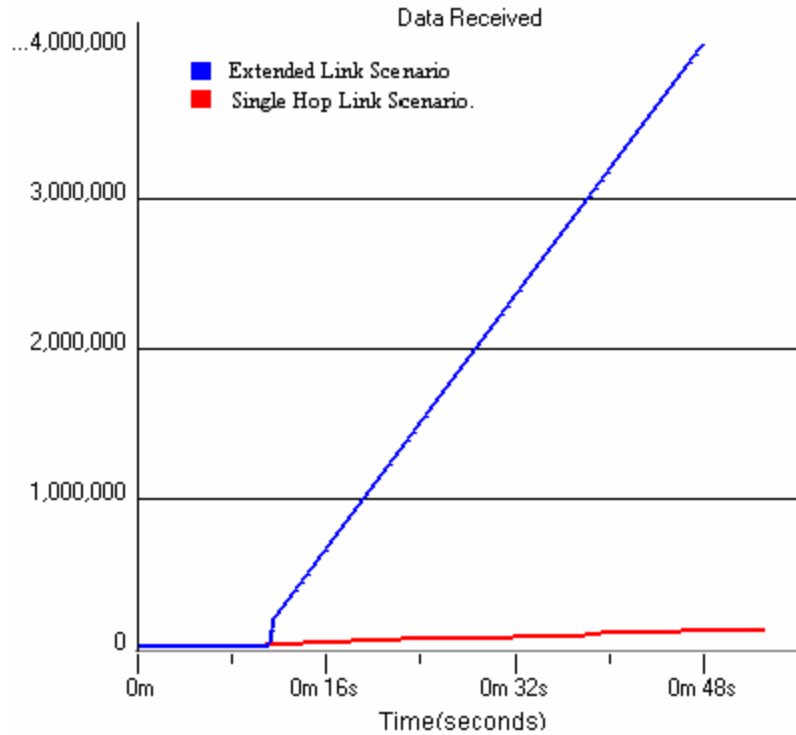

Figure 6.10. Data successfully transmitted from node\_0 to node\_1 (number of bytes).

As mentioned earlier this is an ideal scenario for using extended link because the extended link doesn't interfere with already existing links in the network, thus resulting in the increase in the network throughput and decrease in end-to-end delay for the nodes involved in extended link establishment. The network throughput plot for node\_1 is shown in Figure 6.11.

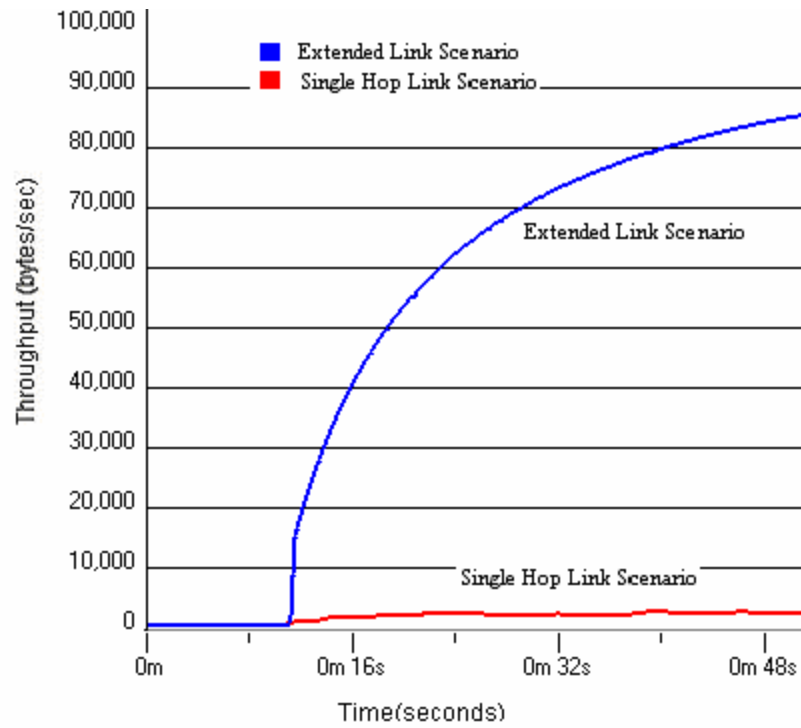

Figure 6.11 Throughput of node\_1

Figure 6.12 illustrates another network topology, Network B. In this network, nodes are randomly distributed in a fixed area as shown.

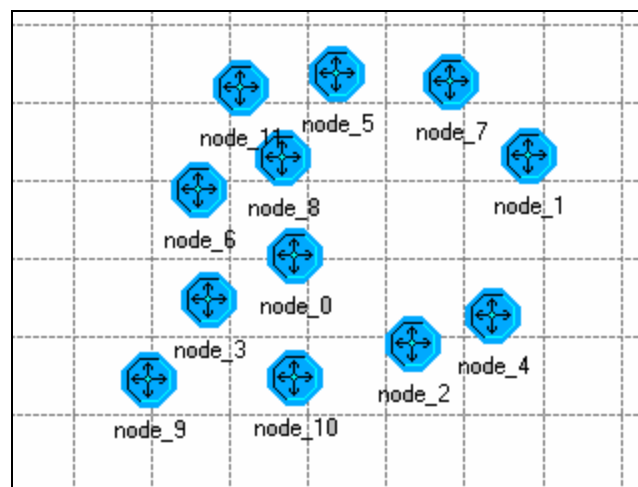

Figure 6.12. Spatial distribution of nodes in network B.

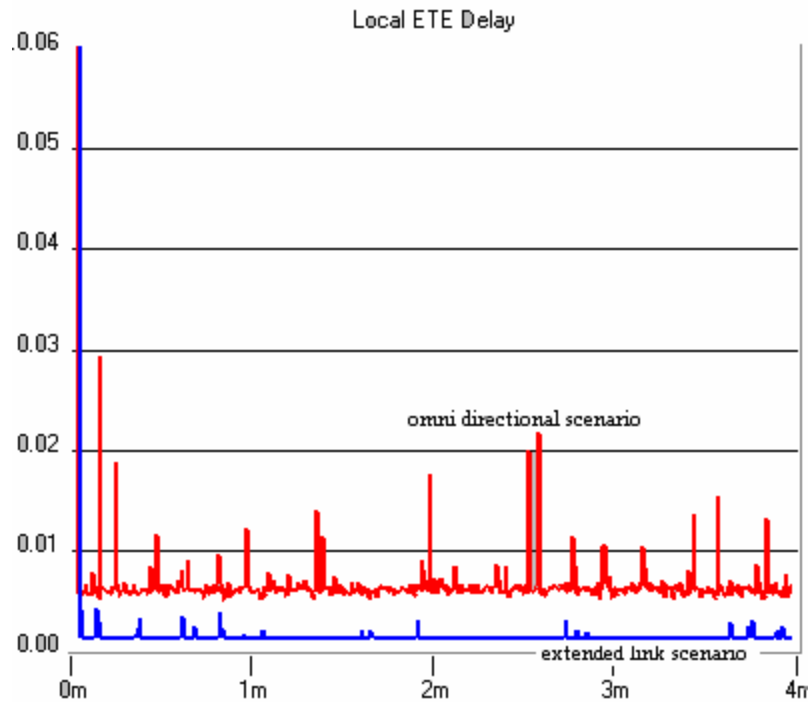

Figure 6.13. End-to-end delay for nodes\_0 and node\_1 in Network B

For this network, simulations are run using the node models `node_dsr_omni` and `node_dsr_extended`. It is observed that although the local end-to-end delay decreases for packets transmitted between nodes `node_1` and `node_0`, the network does not show any improvement in total data successfully transmitted in the network. This is due to the increase in the number of errors as compared to the omni-directional scenario, as shown in Figure 6.16.

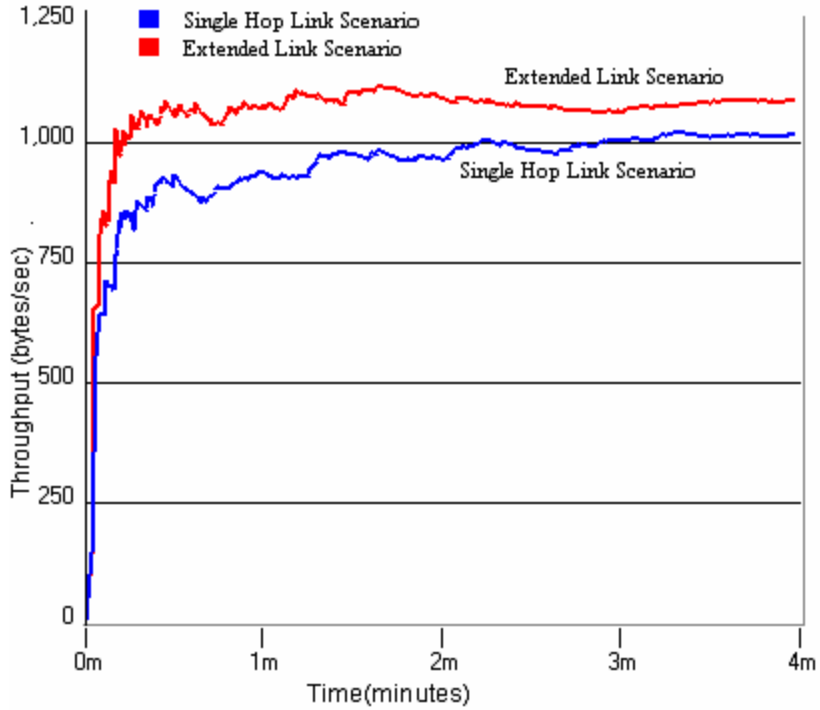

Figure 6.14. Throughput of node\_1

Figure 6.14 shows the throughput of node\_1. We observe slight increase in node\_1 throughput using extended link mechanism in this scenario.

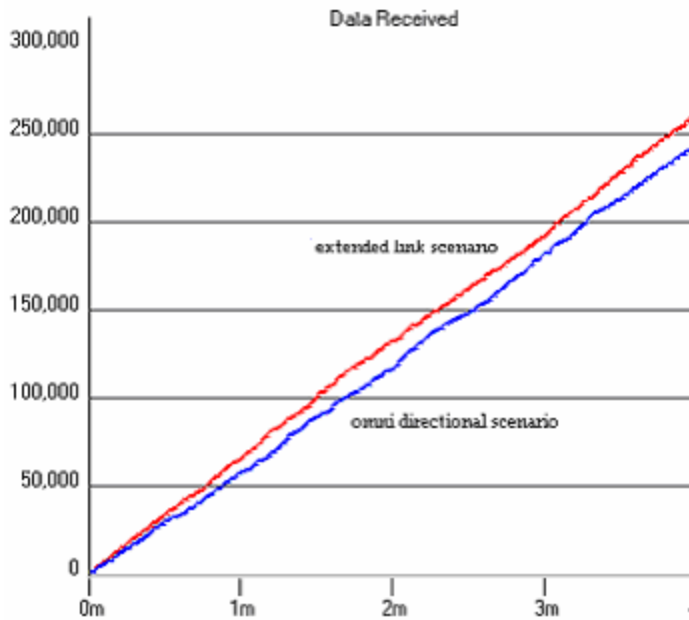

Figure 6.15. Total data received by node\_1 from node\_0 (number of bytes) for network B.

Thus, even though the nodes are able to establish an extended link in network B, the interference due to neighboring nodes increases the number of errors, thus resulting in loss of packets and decrease in overall network throughput.

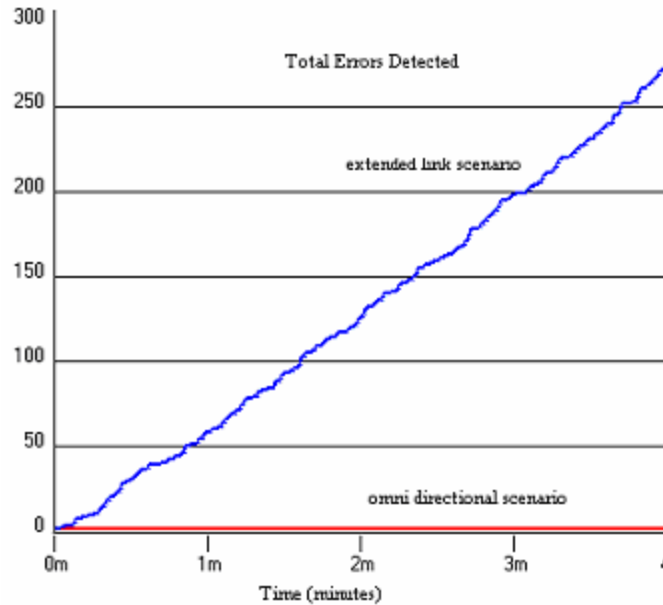

Figure 6.16. Total errors detected.

In Figure 6.17 we illustrate another network C used for comparing the performance of the extended link with an immediate link.

The end-to-end delay is compared for the different scenarios in Figure 6.18. Using the extended link, we observe much lower end-to-end delay as compared to the omni-directional scenario.

As shown in Figure 6.19, using the extended link we do not obtain any improvement in the data received as compared to the omni-directional scenario.

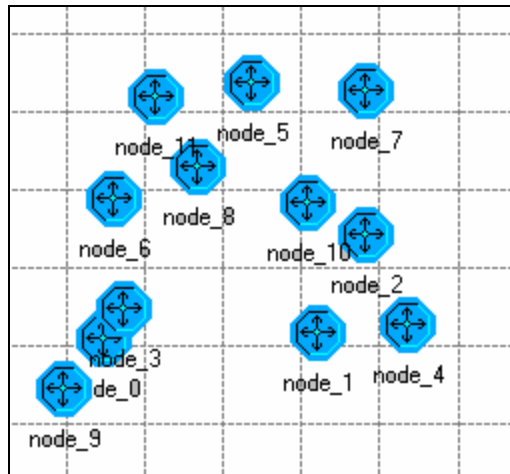

Figure 6.17. Spatial distribution of nodes in network C.

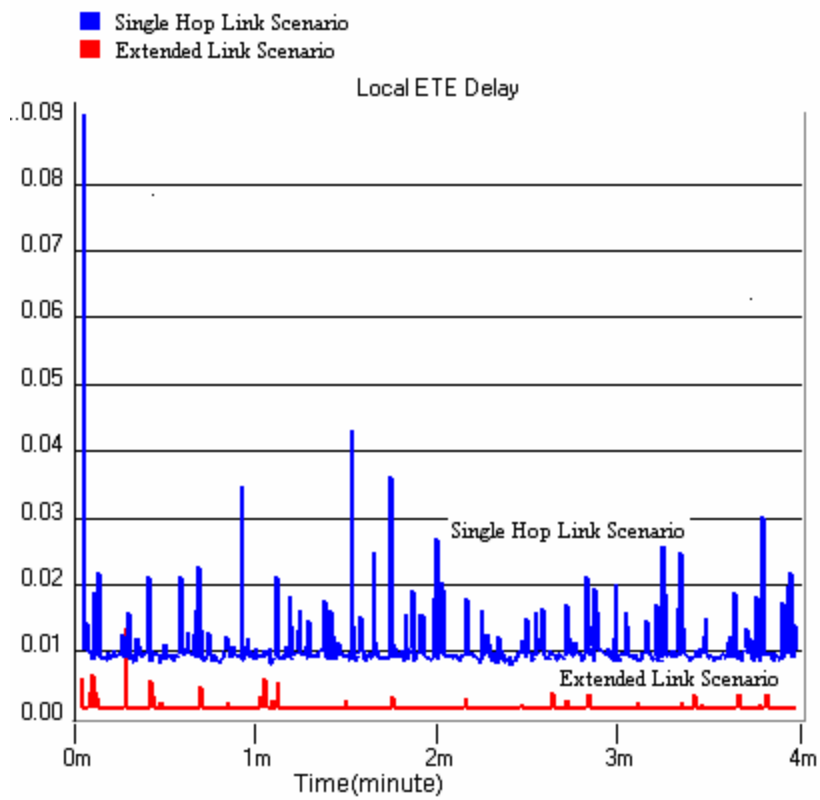

Figure 6.18. ETE delay for Scenario C.



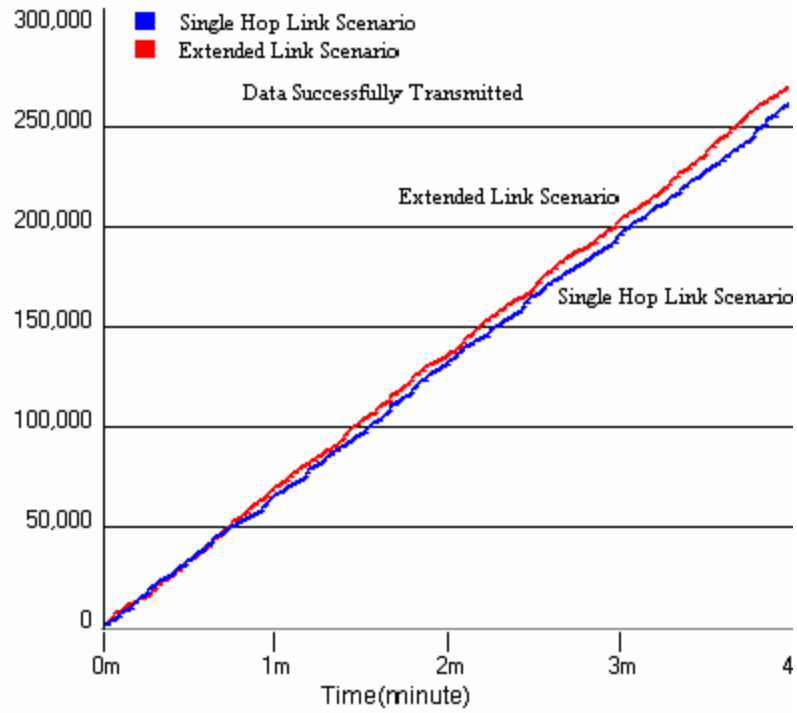

Figure 6.19. Data Received by node\_1 from node\_0 (number of bytes)

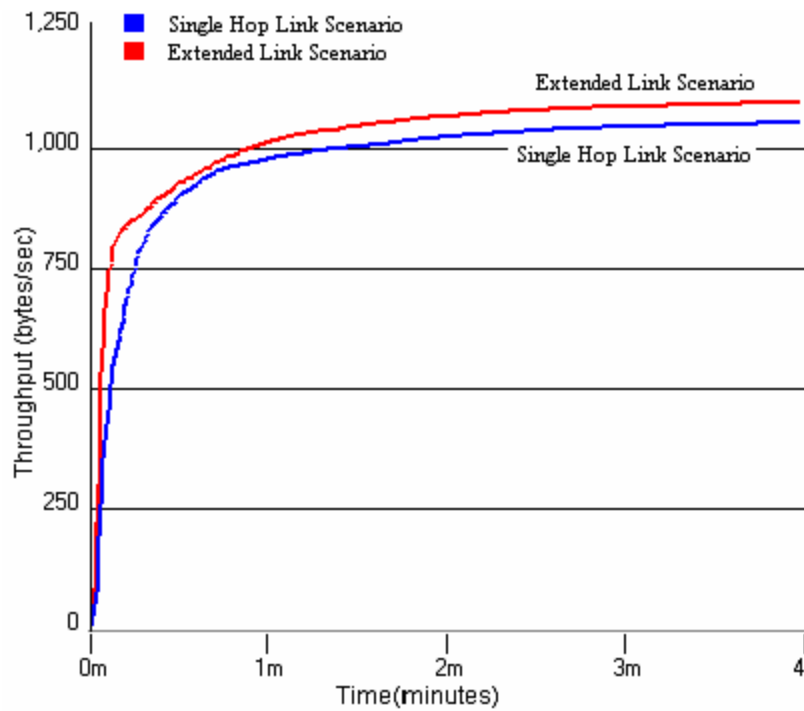

Figure 6.20. Throughput of node\_1

From the results of the three random scenarios presented, we observe that using extended link formation over the basic access medium access control method can provide improvement in end-to-end delay, but may or may not provide gain in terms of network throughput depending on the interfering links in the vicinity of the extended link. The results shown are from typical scenarios for fixed traffic.

In Figure 6.21, Figure 6.22, and Figure 6.23, we show the results obtained by varying traffic in Scenario C. Source inter arrival time  $T$  for all nodes except node\_0 is uniformly distributed between  $(0,t)$  such that  $T \neq 0$  and  $t = \{0.00001, 0.0001, 0.001, 0.01, 0.1\}$ . Inter arrival time for node\_0 is kept constant for all simulations. We observe that the extended link consistently shows improvement in end-to-end delay unlike the performance metric node\_1 throughput and total data successfully transmitted which do not show any consistent pattern.

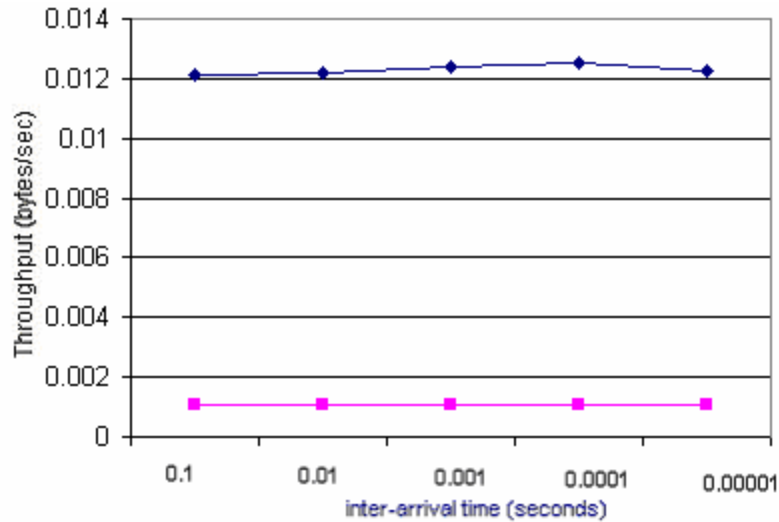

Figure 6.21. End-to-end delay for varying source inter arrival times.

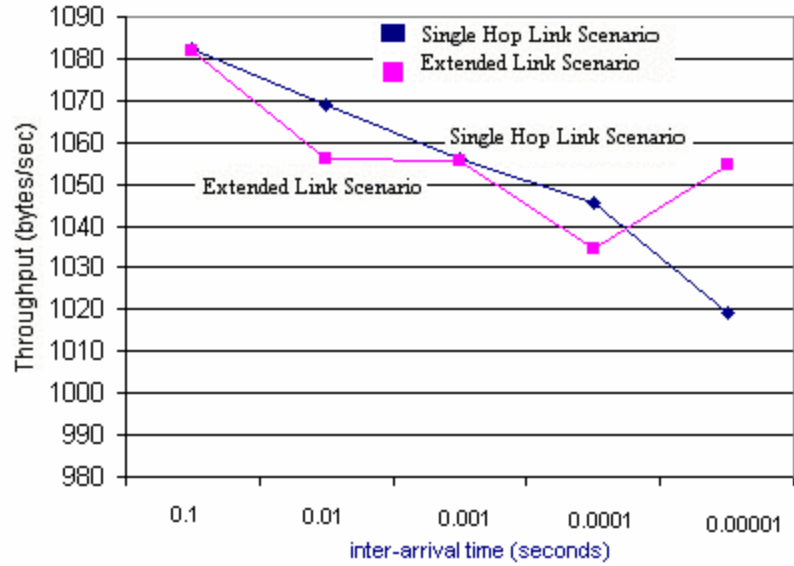

Figure 6.22. Effect of increasing network traffic on throughput of node\_1.

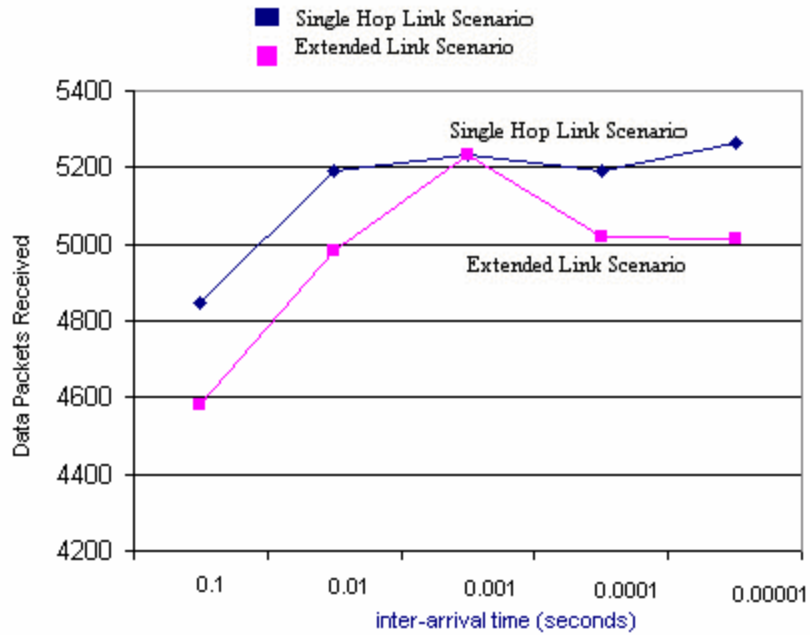

Figure 6.23. Effect of network traffic on total data successfully received (number of packets).

## **6.4 Summary**

In this chapter, we illustrated the simulation model and scenarios used for simulating single-hop wireless networks as well as multi-hop networks. From the single-hop simulations we observe that using directional RTS/directional CTS provides better network performance than directional RTS/omni directional CTS. Single-hop network simulations are followed by multi-hop simulations for comparing the performance of extended link with multihop links. From the simulations we observe that extended links result in decrease in end-to-end delay as compared to multi-hop link. The network throughput of the extended link scenario may be greater or less than that for multihop scenario, depending upon the location of nodes in the vicinity of the two nodes forming the extended link.

# Chapter 7: Conclusions and Future Work

## 7.1 Conclusions

In this thesis we have examined the incorporation of smart antennas into ad hoc networks. The objectives of this thesis were to develop a model for simulating the wireless networks using smart antennas and to propose the use of network layer for extended link formation. Through simulation we observed that using directional RTS/CTS packets provides better network throughput as compared to scenarios using directed RTS and omni-directional CTS. In mesh networks, the use of an extended link allows the transmission of the data using fewer hops. This results in a decrease in the end-to-end delay for the nodes using extended link. The increase in the throughput depends on the spatial location of nodes in the network. If the extended link does not interfere with the immediate links in the network, we observe a dramatic improvement in network throughput. If there is interference between the extended link and the immediate links in vicinity of the nodes forming the extended link, we may not observe an increase in network throughput. In contrast to mesh networks, the performance of directional antennas in mobile ad hoc networks will depend on the mobility of the nodes and the time taken by the angle of arrival determination algorithms. If the time taken to determine the angle of arrival is sufficiently smaller than the duration of packet transmission and the nodes do not move much during this period, then nodes can learn each other's position fairly accurately and the performance approaches that of mesh networks. If the time taken to determine the angle of arrival is comparable to the duration of packet transmission or if the nodes move enough during this period, then use of the directional link establishment mechanisms would lead to worse performance than that of the mesh networks. In extended link formation we have used the basic access method for medium access control. This is in contrast to research by Choudhury, et al. [4] in which authors have used directional RTS for acquiring the channel.

## 7.2 Contribution

We have presented a novel methodology for implementing phased array antennas in OPNET. The model supports linear as well as circular arrays and allows adaptive beam forming as well as null steering. This thesis illustrated how MATLAB and OPNET simulations can be

interfaced to allow the incorporation in OPNET of software and libraries developed in MATLAB. The simulation models that were developed have been used to assess the performance of some of the medium access control protocols based on IEEE 802.11. Medium access control performance assessment is followed by the proposal of the extended link formation using network layer. We have proposed XuDSR based on DSR for multihop networks and used simulations to assess the advantage of establishing the extended link using the basic access method.

### **7.3 Future Work**

Medium access control in wireless networks using smart antennas is still an active topic of research. Besides using immediate links for communications, it opens the possibility of using the extended links in the network for data transmission. One of the next steps of this research involves characterizing the performance of extended links in mobile ad hoc networks. A robust heuristic mechanism is required to determine when to form an extended link. To use the extended links, it might be necessary to interface the heuristic algorithm with a quality of service mechanism, such as a policy-based network management framework. This could help in arbitration if the extended link to be formed might interfere with other immediate links in its vicinity. Further, it might be interesting to characterize network performance using multiple extended hops in comparison to multiple immediate hops, which are currently used in ad hoc networks. Using directional antennas, it may be possible to establish links between nodes using more than one set of paths. To efficiently utilize network resources it is necessary to develop an algorithm to determine which links to establish and which path to use to send data to the destination node in real time. Another challenging task is to investigate the fairness of the medium access control using extended links and determine an algorithm for weighted fair channel allocation using smart antennas.

## References

- [1] The Institute of Electrical and Electronics Engineers, Inc., IEEE Std 802.11 – “Wireless LAN Medium Access Control (MAC) and Physical Layer (PHY) specifications,” The Institute of Electrical and Electronic Engineers, Inc., 1997.
- [2] IEEE 802.11 Family, ZYTRAX Products, [http://www.zytrax.com/tech/wireless/ieee\\_802.htm](http://www.zytrax.com/tech/wireless/ieee_802.htm).  
Date visited: December 2002.
- [3] J. C. Liberti and T. Rappaport, *Smart Antennas for Wireless Communications: IS 95 and Third Generation CDMA Applications*, Prentice Hall, Upper Saddle River, NJ, 1<sup>st</sup> edition, 1999.
- [4] A. Nasipuri, S. Ye, J. You and R. Hiromoto, “A MAC Protocol for Mobile Ad Hoc Networks using Directional Antennas,” *Proc. of the IEEE Wireless Communications and Networking Conference*, Chicago, Illinois, Vol. 3, September 23-28, 2000, pp. 1214-1219.
- [5] R. Choudhury, X. Yang, R. Ramanathan and N. H. Vaidya, “Using Directional Antennas for Medium Access Control in Ad Hoc Networks,” *Proc. of the MOBICOM*, Atlanta, Georgia, September 23-28, 2002, pp. 59-70.
- [6] M. Takai, J. Martin, R. Bagrodia and A. Ren, “Directional Virtual Carrier Sensing for Directional Antennas in Mobile Ad Hoc Networks,” *Proc. of the ACM MobiHoc*, Lausanne, Switzerland, June 9-11, 2002, pp. 183-193.
- [7] M. Sanchez, T. Giles and J. Zander, “CSMA/CA with Beam Forming Antennas in Multi-hop Packet Radio,” *Proc. of the Swedish Workshop on Wireless Ad Hoc Networks*, March 5-6, 2001.
- [8] QualNet simulator , Scalable Network Technologies,

[http://www.scalable-networks.com/training\\_and\\_support/documentation/manuals.php](http://www.scalable-networks.com/training_and_support/documentation/manuals.php). Date visited:  
November 2002.

[9] Online Documentation, OPNET Modeler 8.0.

[10] R. Ramanathan, "On the Performance of Ad Hoc Networks with Beamforming Antennas," *Proc. of the ACM MobiHoc*, Long Beach, California, October 4-5, 2001, pp. 95-105.

[11] Y. B. Ko, V. Shankarkumar and N. H. Vaidya, "Medium Access Control Protocols using Directional Antennas in Ad Hoc networks," *Proc. of the IEEE INFOCOM*, Tel Aviv, Israel, Vol. 1, March 26-30, 2000, pp.13-21.

[12] H. M. Elkamchouchi and M. A. Elsalam, "A New Constrained Fast Null Steering Algorithm," *Proc. of the IEEE Antennas and Propagation Society International Symposium*, Salt Lake City, Utah, Vol. 2, July 2000, pp. 926-929.

[13] P. Enge and P. Misra, "Special issue on GPS: The Global Positioning System," *Proc. of the IEEE*, Vol. 87, No. 1, January 1999, pp. 3-15.

[14] R. Want, A. Hopper, V. Falcao, and J. Gibbons, "The Active Badge Location System," *Proc. of the ACM Transactions on Information Systems*, Vol. 10, No. 1, January 1992, pp. 91-102.

[15] A. Harter and A. Hooper, "A Distributed Location System for the Active Office," *IEEE Network*, Vol. 8, No. 1, January 1994, pp. 62-70.

[16] C. H. Peck, and P.J. Moore, "A Direction-finding Technique for Wide-band Impulsive Noise Source," *IEEE Transactions on Electromagnetic Compatibility*, Vol. 43, No. 2, May 2001, pp. 149-154.



- [17] P. Bahl and V. N. Padmanabhan, "RADAR: An In-Building RF-based User Location and Tracking System," *Proc. of IEEE INFOCOM*, Tel Aviv, Israel, Vol. 2, March 26-30 2000, pp. 775-785.
- [18] J. Broch, D. B. Johnson, D. A. Maltz, "The Dynamic Source Routing Protocol for Mobile Ad Hoc Networks," Internet Draft. draft-ietf-manet-dsr-00.txt, March 1998. Work in progress.
- [19] T. Larsson, N. Hedman, "Routing Protocols in Wireless Ad-hoc Networks – A Simulation Study," <http://www.ietf.org/proceedings/99mar/slides/manet-thesis-99mar.pdf>. Date visited: October 2002.
- [20] Y. Okumura, E. Ohmori, T. Kawano, and K. Fukuda, "Field Strength and Its Variability in VHF and UHF Land-Mobile Radio Service," *Review of the Electrical Communications Laboratory*, Vol. 16, No. 9-10, September-October 1968, pp. 825-873.
- [21] M. Hata, "Empirical formula for propagation loss in Land Mobile radio services," *IEEE Transactions on Vehicular Technology*, Vol. 29, No. 3, August 1980, pp. 317-325.
- [22] DSR model [http://w3.antd.nist.gov/wctg/prd\\_dsrfiles.html](http://w3.antd.nist.gov/wctg/prd_dsrfiles.html). Date visited: April 2002.

## **Vitae**

Vikram Dham earned his Bachelor's degree in Electronics & Electrical Communication from Punjab Engineering College, affiliated to Punjab University, Chandigarh, India. After working for two years as a System Integrator for networks based on Sun and Cisco products, he joined the MSEE program at Bradley Department of Electrical and Computer Engineering, Virginia Tech in Fall 2000. During his M.S he worked on projects involving characterization of protocols for wired as well as wireless networks using discrete event simulator OPNET. His research interests include designing and characterizing the performance of protocols for ad hoc networks.