

# **A Case Study Approach to Identifying the Constraints and Barriers to Design Innovation for Modular Construction**

Joseph M. Schoenborn

THESIS SUBMITTED TO THE FACULTY OF THE  
VIRGINIA POLYTECHNIC INSTITUTE AND STATE  
UNIVERSITY IN PARTIAL FULFILLMENT OF THE  
REQUIREMENTS FOR THE DEGREE OF

MASTER OF SCIENCE  
IN  
ARCHITECTURE

James R. Jones, Chair  
Robert P. Schubert  
Thomas E. Hardiman

April 27, 2012: Blacksburg, VA

*keywords:* prefabrication, industrialization, modularization

Copyright 2012, Joseph Schoenborn

# **A Case Study Approach to Identifying the Constraints and Barriers to Design Innovation for Modular Construction**

Joseph M. Schoenborn

## **ABSTRACT**

It is important for an architect to understand the limiting factors that will affect the design of a modular building. The implementation of modular construction as a means of improving production efficiency and worker safety in the construction industry raises into question the design quality of modular buildings, and whether or not the merits of the building process can also be captured from the perspective of the architect. For this reason, the constraints and barriers to design innovation in modular construction are recorded through the lens of an architect.

This study uses interviews with modular

manufacturers to extract information on the topic of innovation in the industry. Featuring a case study project as the platform for discussion, the opinions of experienced building professionals were sought to identify what is and what isn't possible. Among the primary constraints and barriers to innovation, including manufacturing costs, dimensional requirements based on transportation method, and the inflexibility of CAM software, the results of the study identified a need for architects to become better educated about modular construction in general. Therefore, the information presented is meant to be a teaching tool geared towards architects.

## **ACKNOWLEDGEMENTS**

Special thanks to the participants of this study listed as follows (in alphabetical order):

Ian Peter Atkins  
John S. Catalino  
Donald F. Engle, Jr.  
Dennis Michaud  
John R. Morrison  
Jay Van Vlerah  
Rodney Young

## TABLE OF CONTENTS

ABSTRACT	ii	2.7 Reaction to Literature	18	4.6 Identification of Themes	49
ACKNOWLEDGEMENTS	iii				
TABLE OF CONTENTS	iv	CHAPTER 3: METHODOLOGY	19	CHAPTER 5: DATA ANALYSIS	50
LIST OF FIGURES	v	3.1 Overview of Qualitative Methods	19	5.1 Market Perception	50
LIST OF TABLES	vii	3.1.1 The Case Study Design	19	5.1.1 Marketing and Outreach	50
		3.1.2 Role of the Researcher	21	5.1.2 LEED	51
CHAPTER 1: INTRODUCTION	1	3.1.3 Ethical Considerations	21	5.2 Education	51
		3.1.4 Setting	22	5.2.1 Building Codes	52
CHAPTER 2: LITERATURE REVIEW	3	3.1.5 Actors	22	5.2.2 Transportation	
2.1 Definitions	3	3.1.6 Events	22	Limmitations	53
2.1.1 Prefabrication	3	3.2 Data Collection Tactic	23	5.2.3 Tolerances	53
2.1.2 Preassembly	5	3.2.1 Development of the		5.2.4 Means and Methods	53
2.1.3 Modular Construction	5	Questionnaire	23	5.3 Scope of Work	56
2.1.4 Manufactured Homes	6	3.2.2 Data Recording		5.4 Drawing Duplication	56
2.1.5 Onsite Construction	6	Procedures	23	5.4.1 Shop Drawings	57
2.1.6 Offsite Construction	6	3.2.3 Data Analysis Procedures	24	5.4.2 BIM/3DCAD	57
2.1.7 Modularization	6	3.2.4 Data Coding	24	5.4.3 Paperless Production	57
2.1.8 Industrialization	6	3.2.5 Verification	25	5.5 Impediments to Mass	
2.1.9 Lean Construction	6	3.2.6 Reforting and Findings	25	Customization	58
2.1.10 Modular	6	3.3 The Case Study Project	26	5.6 Offsite/Onsite Interface	59
2.2 Perceived Benefits and		3.3.1 Program	26	5.7 Initial Building Cost	60
Challenges of Modular		3.3.2 Building Systems	27		
Construction	6	3.3.3 Initial Cost Review	29	CHAPTER 6: CONCLUSIONS	62
2.3 Current Trends in Modular		3.4 Description of Participants	30	6.1 Interpretation of Data	62
Construction	8	3.4.1 Company A	30	6.2 Opportunities for Future Study	69
2.4 Cross Industry Learning	9	3.4.2 Company B	31	6.3 Summary of Findings	70
2.5 Innovation in Computer Aided		3.4.3 Company C	32		
Design	10	3.4.4 Company D	32	REFERENCES	71
2.6 Architectural Precedents	12	3.4.5 Company E	32		
2.6.1 Prototyping	13			APPENDIX A: PROJECT DWGS	75
2.6.2 Processed Materials	13	CHAPTER 4: DATA COLLECTION	34	APPENDIX B.1: TRANSCRIPT A	104
2.6.3 Prefabricated		4.1 Company A Interview Summary	34	APPENDIX B.2: TRANSCRIPT B	115
Components	14	4.2 Company B Interview Summary	37	APPENDIX B.3: TRANSCRIPT C	127
2.6.4 Panelized Structures	14	4.3 Company C Interview Summary	41	APPENDIX B.4: TRANSCRIPT D	135
2.6.5 Modular Structures	15	4.4 Company D Interview Summary	44	APPENDIX B.5: TRANSCRIPT E	146
2.6.6 Manufactured Homes	16	4.5 Company E Interview Summary	48	APPENDIX C: IRB PROTOCOL	149

## LIST OF FIGURES

<b>Figure 2.1.1.1</b> Habitat '67 by Mosche Safdie (Safdie 1970, 23)	4	<b>Figure 2.6.1.2</b> Garden Prototype by Kierran Timberlake Architects (Kieran Timberlake 2007)	13	<b>Figure 3.4.2.2</b> picture taken at Company B's factory	31
<b>Figure 2.1.1.2</b> Furniture House by Shigeru Ban (McQuaid 2003, 167)	4	<b>Figure 2.6.4.1</b> Acorn House by Carl Koch (Koch 1958, 91)	15	<b>Figure 3.4.2.3</b> picture taken at Company B's factory	31
<b>Figure 2.1.1.3</b> IBM Traveling Pavilion by Renzo Piano (Dini 1984, 79)	4	<b>Figure 2.6.4.2</b> Acorn House foundation installation (Koch 1958, 93)	15	<b>Figure 3.4.2.4</b> picture taken at Company B's factory	31
<b>Figure 2.1.1.4</b> Eames House by Charles and Ray Eames (Smith 2007, 23)	4	<b>Figure 2.6.5.1</b> Container Kit home by Lot-EK (Lot-EK)	16	<b>Figure 5.2.2.1</b> example of a module on a double-drop trailer bed	54
<b>Figure 2.1.3.1</b> typical modular construction schedule (Permanent Modular Construction 2011: Annual Report 2011, 3)	5	<b>Figure 2.6.5.2</b> rendering of O'Connell East Architect's and CTZWG's Victoria Hall (OCA)	17	<b>Figure 5.2.2.2</b> comparison of maximum module lengths base on different shipping methods	54
<b>Figure 2.2.1</b> perceived benefits of modular construction (Haas et al 2000, 17)	7	<b>Figure 2.6.5.3</b> rendering of SHoP Architect's B2 Brooklyn Building for Atlantic Yards (SHoP Architects)	17	<b>Figure 5.2.4.1</b> common modular structure (Reidelbach 1971, 126)	55
<b>Figure 2.2.2</b> perceived constraints to modular construction (Haas et al 2000, 18)	7	<b>Figure 3.3.1.1</b> single classroom exploded axonometric	26	<b>Figure 5.2.4.2</b> steel connections (Allen and Iano 2004, 392)	55
<b>Figure 2.4.1</b> Wichita House by Buckminster Fuller (Arieff 2002, 17)	10	<b>Figure 3.3.1.2</b> duplex option exterior photomontage	27	<b>Figure 5.2.4.3</b> steel connections (Allen and Iano 2004, 394)	55
<b>Figure 2.4.2</b> patent drawings for Buckminster Fuller's Dymaxion Car (Fuller and Marks 1973, 49)	10	<b>Figure 3.3.1.3</b> one, two, and three classroom options	27	<b>Figure 5.2.4.4</b> module cross section (Reidelbach 1971, 137)	55
<b>Figure 2.5.1</b> MasterCAM x2 model	11	<b>Figure 3.3.2.1</b> SIP assembly, drawing by Brendan Johnston	28	<b>Figure 5.5.1</b> stool design by Patrick Chia (Piller 2006, 6)	58
<b>Figure 2.5.2</b> Rhino 3-dimensional model	11	<b>Figure 3.3.2.2</b> SIP assembly, drawing by Brendan Johnston	28	<b>Figure 5.7.1</b> the life cycle value of materials (Blengini 2009, 322)	60
<b>Figure 2.5.3</b> CNC-milled 4x4	11	<b>Figure 3.3.2.2</b> SIP assembly, drawing by Brendan Johnston	28	<b>Figure 6.1.1</b> Triad/Ruvo automated machine for steel wall and floor panel fabrication (Deluxe Building Systems 2009)	66
<b>Figure 2.6.1</b> a Sears Roebuck House of the 1920's (Small Houses of the Twenties 1991, 21)	12	<b>Figure 3.4.1.1</b> picture taken at Company A's factory	30	<b>Figure 6.1.2</b> component assembly line (Reidelbach 1971, 154)	67
<b>Figure 2.6.1.1</b> Case Study House #22, the Stahl House, by Peter Koenig (Smith 2007, 68)	13	<b>Figure 3.4.1.2</b> picture taken at Company A's factory	30	<b>Figure A.1</b> two-classroom rendering	76
		<b>Figure 3.4.1.3</b> picture taken at Company A's factory	30	<b>Figure A.2</b> building diagram	77
		<b>Figure 3.4.2.1</b> picture taken at Company B's factory	31	<b>Figure A.3</b> SIP panel design with embedded cam locks, drawing by Brendan Johnston	78
				<b>Figure A.4</b> cam lock mechanism, image provided by Vera Novak	78

<b>Figure A.5</b> light, cold-formed steel structure (Lite Steel Technologies America 2008)	78	<b>Figure A.19</b> light shelf design (Lechner 2009, 323)	83	<b>Figure A.42</b> detail plan of connected pods with door partition	96
<b>Figure A.6</b> phenolic resin skin (DuraSip)	78	<b>Figure A.20</b> interior rendering	84	<b>Figure A.43</b> detail plan of corner condition	97
<b>Figure A.7</b> pod variation design, drawing set by Josh Lilly	79	<b>Figure A.21</b> exploded axonometric	85	<b>Figure A.44</b> typical corner section	97
<b>Figure A.8</b> helical pile (Foundation Supportworks 2012)	80	<b>Figure A.22</b> pod component assembly	86	<b>Figure A.45</b> detail section through beams	98
<b>Figure A.9</b> cork floor tiles (Home Sevice Publications 2012)	80	<b>Figure A.23</b> panel and clerestory assembly	87	<b>Figure A.46</b> typical cross section	98
<b>Figure A.10</b> grey water purification system (Aquaco Grey Water Recycling System 2010)	80	<b>Figure A.24</b> floor component assembly	88	<b>Figure A.47</b> detail section through clerestory	99
<b>Figure A.11</b> solar thermal panel (Solar Thermal Heating)	81	<b>Figure A.25</b> roof component assembly	89	<b>Figure A.48</b> typical section through pod	99
<b>Figure A.12</b> photovoltaic array (Applied Solar Technology 2012)	81	<b>Figure A.26</b> location of cam lock mechanisms	90	<b>Figure A.49</b> photomontage	100
<b>Figure A.13</b> heat exchanger with enthalpy wheel (BuildingGreen 2012)	81	<b>Figure A.27</b> detail section	90	<b>Figure A.50</b> plan option	100
<b>Figure A.14</b> LED light tubes (Energy Solutions Center 2007)	82	<b>Figure A.28</b> detail plan	90	<b>Figure A.51</b> detail section of classroom connecting to corridor	101
<b>Figure A.15</b> adjustable interior shades (Eartheasy.com 2011)	82	<b>Figure A.29</b> photomontage	91	<b>Figure A.52</b> detail plan of corner component connecting to classroom	101
<b>Figure A.16</b> soy-based foam insulation SIP's, image provided by Vera Novak	82	<b>Figure A.30</b> fit-out plan	91	<b>Figure A.53</b> photomontage	102
<b>Figure A.17</b> phenolic resin sheets customizable in color and surface texture (Focus Technology Co. 2012)	83	<b>Figure A.31</b> detail plan at floor/wall component connection	92	<b>Figure A.54</b> plan option	102
<b>Figure A.18</b> Magnum Board building product used in place of gyp board (Magnum Building Products 2012)	83	<b>Figure A.32</b> typical section through beams	92	<b>Figure A.55</b> detail section of stacked pod configuration	103
		<b>Figure A.33</b> typical clerestory detail	93	<b>Figure A.56</b> section of stacked pods	103
		<b>Figure A.34</b> typical wall component detail	93		
		<b>Figure A.35</b> detail of pod connection to clerestory component	94		
		<b>Figure A.36</b> pod section	94		
		<b>Figure A.37</b> detail of floor component connection to pod	95		
		<b>Figure A.38</b> pod section	95		
		<b>Figure A.39</b> pod detail section	95		
		<b>Figure A.40</b> detail plan of end pod condition	96		
		<b>Figure A.41</b> detail plan of connected pods	96		
				Cover Image by Josh Lilly	

## LIST OF TABLES

<b>Table 2.1.1.1</b> <i>classification of prefabricated systems (Sylvester 2004)</i>	4	<b>Table 5.2.2.1</b> <i>transportation requirements by state (Oversized Load, Permit and Pilot Car Requirements 2011)</i>	54
<b>Table 3.1.1.1</b> <i>assumptions of qualitative design (Creswell 2009, 179)</i>	20		
<b>Table 3.4.1</b> <i>comparative table summarizing the size and experience of Companies A, B, C, D, and E, and the experience of the stateholders</i>	32		
<b>Table 4.1.1</b> <i>themes and pertinent information identified from the interview with Company A</i>	37		
<b>Table 4.2.1</b> <i>themes and pertinent information identified from the interview with Company B</i>	40		
<b>Table 4.3.1</b> <i>themes and pertinent information identified from the interview with Company C</i>	44		
<b>Table 4.4.1</b> <i>themes and pertinent information identified from the interview with Company D</i>	47		
<b>Table 4.5.1</b> <i>themes and pertinent information identified from the interview with Company E</i>	48		
<b>Table 5.2.1.1</b> <i>state departments identified as governing bodies in charge of defining commercial modular building codes (both relocatable buildings and PMC) and certifying third-party inspection agencies (Relocatable Buildings: 2011 Annual Report 2011, 20)</i>	52		

## CHAPTER 1: INTRODUCTION

The benefits of modular construction can be quantified through a comparative analysis of selected buildings. A 2011 study by McGraw Hill Construction conducted among architects, engineers, contractors, and building owners supports the arguments that speed to completion, quality, and safety can be increased with modular construction, while overall costs, material waste, and the impact on the environment can be reduced (Bernstein, Gudge, and Laquidara-Carr 2011, 39-47). As a result, the number of buildings incorporating prefabrication over the past 15 years has increased by 86% (Haas et al. 2000, 29). Unfortunately it seems that innovation in the modular construction industry is slow to adapt. The identification of the constraints and barriers to innovation in modular construction however can be more subjective. The technical limitations of different modular manufactures and the varying degree to which prefabrication and preassembly are used make a comparative study difficult. A survey of architects, engineers, and general contractors in 2007 indicated that

the perceived challenges to using prefabrication includes transportation restrictions on design and construction schedule rigidity (the inability for changes to be made during construction) (Bertelsen 2004, 127). However, these results were drawn without the perspective of manufactures with experience in component prefabrication and preassembly.

A perceived lack of innovation in modular construction projects to date raises the question of why, or what is holding the industry back. The problem is that industry-wide design limitations and restrictions prohibiting building construction methods or materials are not clearly known to architects. This study therefore was designed to discover the challenges presented to architects involved in the design of modular buildings. Upon completion, the results can then be used for future research aimed at nullifying these constraints and barriers to design innovation for modular construction.

The purpose, ultimately, was to list these con-



straints and barriers using information gathered from the analysis of a case study project. The research is presented as an exploratory case study, with the aim of being able to provide an understanding of how design and fabrication processes influence one another – design pushing innovation in the building process and the use of technology, and the fabrication process defining the parameters of design. For the purposes of this study, the topic of innovation in modular construction is demonstrated through mass customization featured in the design of the case study project. The impediments to design innovation were therefore discovered through thoughts shared by professionals through interview tactics.

What is the current level of involvement with architects in the commercial modular building industry? And how often are advantageous changes in the manufacturing processes pursued? Known technical limitations are consistently being overcome because technological innovation is a byproduct of design ingenuity. This research focuses on the interactions between professionals in order to both define the current barriers and constraints, and to collectively hypothesize on how they can be overcome.

Analysis of the case study project was completed through interviews with stakeholders from the modular construction industry. The study was confined to interviews with five different modular building manufacturers. Companies predominantly work on non-residential, permanent buildings. The questions

asked in the interviews focused on the topics of initial building costs versus life cycle costs, the fabrication and transportation of building components, the required quality of and access to construction documents, the ability for a diverse library of building components to be developed, and the differences in the market perception of offsite construction versus onsite construction.

## CHAPTER 2: LITERATURE REVIEW

### 2.1 Definitions

Commercial modular manufacturers were consulted for this study, and so the information and nomenclature presented will remain consistent with the modular construction industry. But even though the terms used may refer specifically to the modular construction industry, the concepts identified are likely applicable to multiple levels of prefabrication or offsite construction. The definitions used for the purposes of this research include the following:

#### 2.1.1 Prefabrication

*Prefabrication* encompasses the construction of all building components that are a part of a larger final assembly (Gibb 1999, 1). Prefabrication is an offsite manufacturing process that takes place at a specialized facility in which various materials and building systems are joined to form a component or part of a larger final installation (Haas et al. 2000, 4). Work is done at a remote location for increased construction speed and quality. The type of prefabricated components vary based

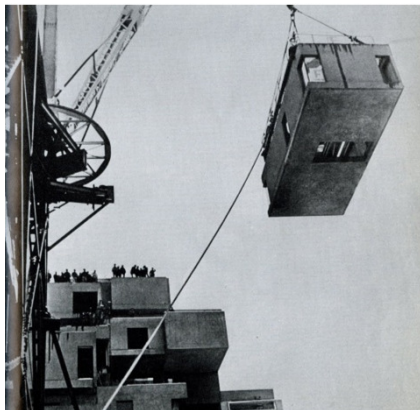
on size and complexity (including the amount of finish work done in the factory and the number of building trades involved on a single component), and based on the amount of labor required for onsite assembly. Components can be categorized into four types:

- 1) *Processed materials* are pre-cut structural or cladding materials custom fabricated through a manufacturing process.
- 2) *Prefabricated components* are simple building blocks that usually involve a single building trade. The vast majority of buildings constructed today use some form of prefabrication. Applications include timber frame panels, precast panels, steel frame panels, structurally insulated panels (SIP's), building envelope/façade systems, composite panels, precast cladding, Light Steel Frame Building Systems (LSF), pre-cast structural elements, insulating concrete formwork (ICF), and tunnel form construction (Hartley and Blagden 2007, 12).

▶ decreasing size of prefabricated components/amount of preassembly  
 increasing degree of onsite construction labor ▶

**Modular Structures** ▶ **Panelized Structures** ▶ **Prefabricated Components** ▶ **Processed Materials**

Components that are volumetric in shape and that form a completed part of a building (or a complete building in itself), and involves more than one trade typically with finished interior and exterior surfaces.



**Figure 2.1.1.1** *Habitat '67* by Mosche Safdie: Habitat is an assembly of prefabricated concrete modules (Safdie 1970, 23).

Components that are comprised of a series of prefabricated elements (window assemblies, door assemblies, wall panels) but do not enclose usable space themselves, typically forming the shell only of a building and require more onsite work than 3-dimensional components but will be cheaper to ship to the site in a compact form.



**Figure 2.1.1.2** *Furniture House* by Shigeru Ban: Ban used panelized structures for the interior structural skeleton of the building (McQuaid 2003, 167).

Refers to any single assembly fabricated in the factory, usually because it cannot be built onsite or can be used to assist construction speed or quality.



**Figure 2.1.1.3** *IBM Traveling Pavilion* by Renzo Piano: This was a moving exhibition that was broken down into a series of prefabricated components that were designed with demountability and reassembly in mind (Dini 1984, 79).

Building elements fabricated offsite and shipped to the building site constitute the majority of the materials used in construction today, enabling larger spans, custom finishes, and the introduction of economies of scale to the bill of materials.



**Figure 2.1.1.4** *Eames House* by Charles and Ray Eames: The Eames house was famously designed to be built from 'off-the-shelf' standardized materials as much as possible (Smith 2007, 23).

**Table 2.1.1.1** *classification of prefabricated systems*: Representing the varying levels of prefabrication used in construction, iconic architectural buildings are presented to help label the four categories discussed in this chapter based on the size of components and the amount of preassembly done in the factory to reduce the amount of onsite construction work required after delivery (sylvester 2004).

- 3) *Panelized structures* are an assembly of prefabricated components that do not enclose usable space. They form a considerable percentage of the final building envelope prior to shipment in compact form on a flatback trailer.
- 4) *Modular structures* are volumetric offsite fabrications that form an enclosed usable space. Modules are structurally independent and include more than one building trade. This category can be broken down further based on size. Larger modules are shipped by themselves and generally comprise more than one room of the final building. The term ‘pod’ refers to one-room modules; the most common applications today are bathroom pods for site built high-rises. ‘Interstitial modules’ are non-inhabitable spaces including finished roof components or floor and ceiling plenums.

**2.1.2 Preassembly**

*Preassembly* involves the joining of prefabricated components together away from the final building site to form either a complete building or a building system. Preassembly can be done either offsite (at a manufacturer’s factory) or onsite, and promotes parallel fabrication practices (Haas et al. 2000, 4). Work typically requires multiple building trades and the placement of preassembled components that often requires the utilization of a crane.

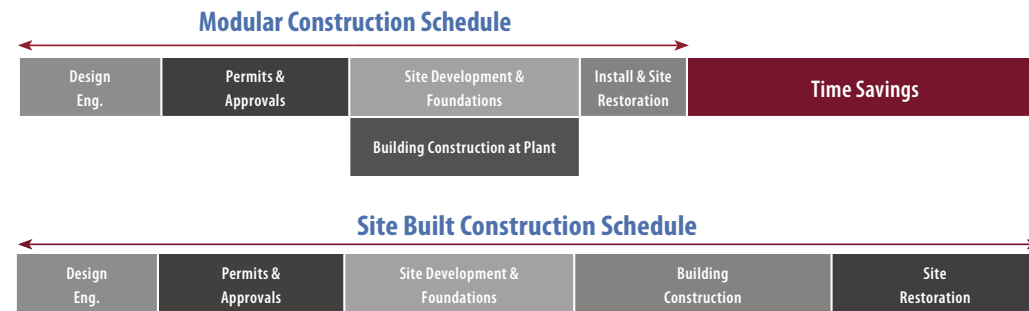
**2.1.3 Modular Construction**

*Modular construction* is a manufacturing pro-

cess defined by the use of prefabrication and preassembly at a remote location to compose volumetric components (modular structures) which are transported as largely finished components to a building site. The Modular Building Institute (MBI) categorizes commercial modular buildings as being 60-80% completed offsite before being shipped to an end destination (Permanent Modular Construction 2011: Annual Report, 2-4). The divisions within the modular construction industry include the following:

- 1) *Permanent Modular Construction (PMC)* provides a service comparable to onsite construction where components are attached to a permanent foundation. Components can be integrated into site built projects or stand-alone buildings. While

costs are likely competitive to an onsite construction process, the time savings accrued from the simultaneous scheduling of offsite and onsite work enables clients to turn profits quicker and save the money spent on employee displacement. PMC buildings are the most likely to involve the assistance of an architect, yet the industry currently can stake claim to only 1% of the overall commercial building market. A typical job will be financed by a private owner with the work being coordinated between an architectural and engineering group, a modular manufacturer, and an onsite general contractor (unless the manufacturer is licensed and staffed to work outside of the factory) (Permanent Modular Construction 2011: Annual Report 2011, 2).



**Figure 2.1.3.1** typical modular construction schedule: Time savings attributed to modular construction revolve around the fact that onsite construction can be done in parallel to offsite component fabrications (Permanent Modular Construction 2011: Annual Report, 3).

2) *Relocatable buildings* maintain their mobility, serving temporary functions for both partial and full building applications usually built on an integrated chassis with detachable wheels, hitch, and axels. While the industry has a history of providing temporary solutions for construction sites and schools, the current trend is to provide durable buildings that will serve multiple functions throughout its life cycle. Modules are largely complete with finishes done in the factory and require minimal onsite work. There are an estimated 550,000 relocatable buildings in North America, including 180,000 owned by school districts, 120,000 leased by dealers to schools, and 250,000 leased by dealers for various business occupancies including construction site offices and temporary sales offices. Major construction companies also own uncouncted “fleets” for site construction site offices (Relocatable Buildings: 2011 Annual Report 2011, 3).

#### **2.1.4 Manufactured Homes**

*Manufactured homes* are relocatable buildings that are regulated federally by the US Department of Housing and Urban Development (HUD), superseding all local or state building codes. This term applies to only single-wide or double-wide residential buildings with an integrated chassis built for mobility, not large-scale residential projects, and are generally considered as being built to a lower standard of quality.

#### **2.1.5 Onsite Construction**

*Stick built construction* is used interchangeably with *onsite construction* and *in-situ construction*. The term stick built historically refers to dimensioned lumber construction, but it will be used here for any construction done onsite.

#### **2.1.6 Offsite Construction**

*Offsite construction* includes prefabrication and/or preassembly away from the final building site. The term is traditionally used in the UK, where prefabricated components are instead categorized as ‘non-volumetric offsite fabrications,’ ‘volumetric offsite fabrications,’ and ‘modular buildings’ (Gibb 1999, 8). In this study, offsite construction is used to describe the use of prefabrication and preassembly in generic terms.

#### **2.1.7 Modularization**

*Modularization* generally refers to a process of breaking a complete building down into a series of smaller modules constructed offsite so that onsite construction is reduced to foundation work and module assembly. While the modular manufacturer has more control over quality and the production schedule, the major downside to modularization is the fact that shipping large empty volumes is costly.

#### **2.1.8 Industrialization**

*Industrialization* is used to describe the automation of building construction utilizing advanced equipment and technology to minimize human involvement.

#### **2.1.9 Lean Construction**

*Lean construction* principles revolve around reducing waste of materials and money for industrial production. While prefabrication and the integration of BIM into the process are suggested, the strategies of lean construction will not be discussed in this book.

#### **2.1.10 Modular**

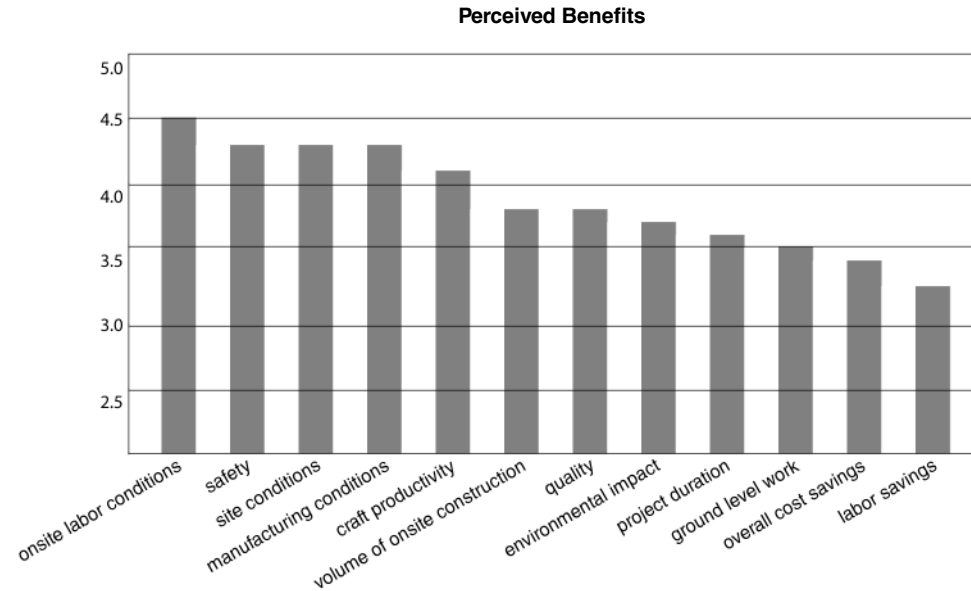
*Modular* is a term that is identified with standardized units or dimensions. It will not be used by itself in this book.

### **2.2 Perceived Benefits and Challenges of Modular Construction**

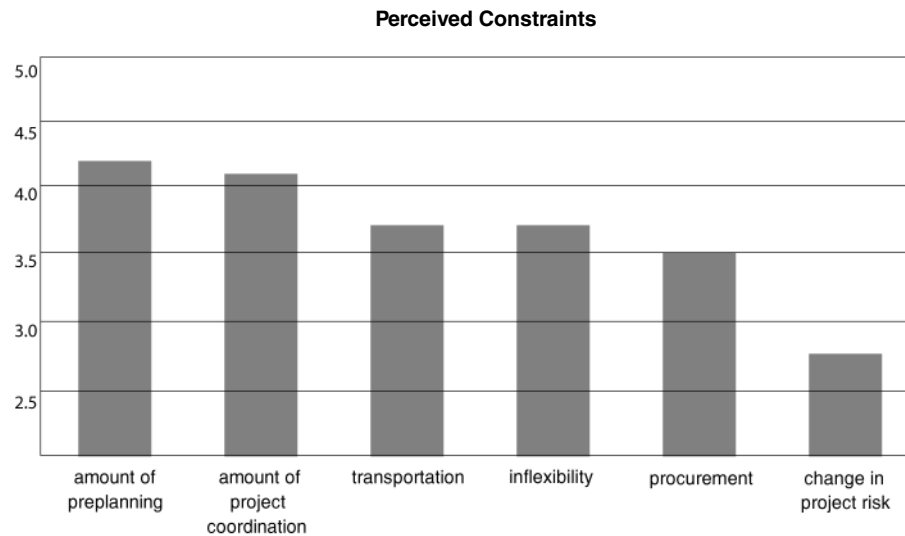
A study conducted at the Graduate School of the University of Clemson by Lu Na in 2000 revealed the perceived benefits and limitations to using prefabricated components. The survey received responses from a mixture of 138 practicing architects, engineers, and general contractors in the U.S. The benefits associated with prefabrication revealed in the study included the following (Lu 2007, 126-127):

- 1) Reduced overall construction time and efficient scheduling due to parallel production activities
- 2) Increased building quality and craftsmanship
- 3) Increased labor productivity
- 4) Increased labor safety
- 5) Reduced construction schedule disruptions due to the use of a weather-protected work environment
- 6) The minimal environmental impact of the construction process on the site

**Figure 2.2.1** *perceived benefits of modular construction*: Figure is based on a study using a 5-point Likert scale where ratings between from 3 to 5 are considered advantages, and ratings from 1 to 3 are not considered advantages (Haas et al 2000, 17).



**Figure 2.2.2** *perceived constraints to modular construction*: Figure is based on a study using a 5-point Likert scale where ratings between from 3 to 5 are considered impediments, and ratings from 1 to 3 are not considered impediments (Haas et al 2000, 18).



Additional benefits commonly associated with prefabrication include the reduction of onsite labor congestion and onsite labor volume, the overall cost reduction of construction as a result of efficient work scheduling, and the accessibility to advanced computer technology and equipment (Haas et al. 2000, 23).

The constraints to using prefabricated components identified included (Lu 2007, 127):

- 1) The effects of transportation restrictions on design
- 2) The inability for changes to be made during the construction process

Increased design costs and engineering work required upfront are also typically referred to as barriers to prefabrication (Haas et al. 2000, 24).

### **2.3 Current Trends in Modular Construction**

The National Institute of Standards and Technology (NIST) recommended an increased use of prefabricated components and preassembly as being one of the top five opportunities for breakthroughs in the construction industry (Improving Construction 2010, 1). General contractors outsource prefabricated work because they require the following to be competitive (Chiang, Tang, and Wong 2008, 168):

- 1) Market share
- 2) Know how

### **3) Financing**

While the benefits are currently known to both clients and general contractors, stick built construction is still used in 75% of new houses built in the US (Lu 2007, 56). Studies have shown that there simply is not a competitive marketing advantage to the use of modular construction over stick built construction (Chiang, Tang, and Wong 2008, 165).

A 2007 article in *Building and Environment* indicated that the following strategies are required in order for modular construction to be considered cost effective (Tam et al. 2007, 3652):

- 1) Complete mechanizing of the production process
- 2) Eliminating the amount of site work required as much as possible
- 3) Maximizing the usage of recycled materials for prefabricated building components

There can be a stigma of poor building quality associated with modular construction due to a history of cheap manufactured buildings. This public perception was overcome by German manufacturers through quality certification schemes, consistent promotional marketing of the benefits of offsite construction, and the standardization of components (increasing efficiency and productivity) (Lu 2007, 47).

Prefabricated components are still used today in the majority of new building construction.

The building trades that are identified as using prefabricated components most effectively were ranked as follows (Haas et al. 2000, 19):

- 1) Piping
- 2) Mechanical
- 3) Structural assemblies
- 4) Equipment
- 5) Ironworks
- 6) Instrumentation
- 7) Welding
- 8) Electrical
- 9) Concrete
- 10) Insulation
- 11) Carpeting
- 12) Finishes
- 13) Furnishings
- 14) Masonry
- 15) Roofing
- 16) Plastics

And although skill levels required for prefabrication is no different than that in traditional stick built construction, the cost of labor was shown to be lower (Haas et al. 2000, 24).

A 2011 study by McGraw Hill Construction – a part of the McGraw Hill Companies which provides construction project and product information, plans and specifications, industry news, market research, industry trends and forecasts – was conducted to document the current state of the modular building industry. The major factors influencing interest in prefabrication and modularization include the development of lean construction techniques,

the emergence of BIM as the preferred tool of architects and clients to document construction, and the recognition of the importance of sustainable or green building (Bernstein, Gudgel, and Laquidara-Carr 2011, 7). Currently, the type sectors most using prefabrication and modularization for new construction are ranked as follows (Bernstein, Gudgel, and Laquidara-Carr 2011, 6-11):

- 1) Healthcare buildings
- 2) Higher education buildings
- 3) Manufacturing buildings
- 4) Low-rise offices
- 5) Public buildings

Conversely, architects are most interested in using prefabrication for the following types of projects:

- 1) Multi-family residential
- 2) K-12 schools
- 3) Hotels and motels

The building elements that prefabrication is primarily used for includes the following:

- 1) Building superstructure
- 2) Exterior walls
- 3) Roof construction

Meanwhile, the primary reasons for architectural integration of prefabricated components into a project include the following:

- 1) Owner demand
- 2) Improve quality

### 3) Save time

The recommendations of the study include the education of clients on the productivity and business benefits of prefabrication, the development of BIM objects by the modular manufacturers to make it easier for architects to specify products in their design, and to promote the green benefits of prefabrication to make it stand out to both architects and clients as a positive alternative to onsite construction (Bernstein, Gudgel, and Laquidara-Carr 2011, 6-11).

### 2.4 Cross Industry Learning

Mass customization is defined in detail by Kieran and Timberlake in *Refabricating Architecture*. It is used effectively today in industrial design. For example, Toyota automobiles, Dell computers, and Nike shoes divide the manufacturing process of their products into two primary parts: a base model with features included that are considered necessary, and auxiliary features that are available for inclusion based on the demand of consumers (Jacobs 2007, 27). In the case of buildings, the structural skeleton acts as the canvas for architects to address issues of site, function, and the demands of a client. The Sekisui house model in Japan, for example, is comprised of 30,000 components with more than 2 million available so that a high degree of customization is possible (Lu 2007, 45).

While onsite construction phasing is dictated by gravity, requiring the sequential coordination of building trades, modular manufacturers

decide the means, methods and sequence of construction by expanding the supply chain into specialized groupings (Kieren and Timberlake 2004, 31). Again using the model of the car manufacturer, assemblies are organized linearly enabling the simultaneous production of components to reduce labor congestion and increase overall quality and productivity. Project management thereby utilizes a tiered structure – depending on the degree to which components are broken down and integrated in a final assembly (Kieren and Timberlake 2004, 55).

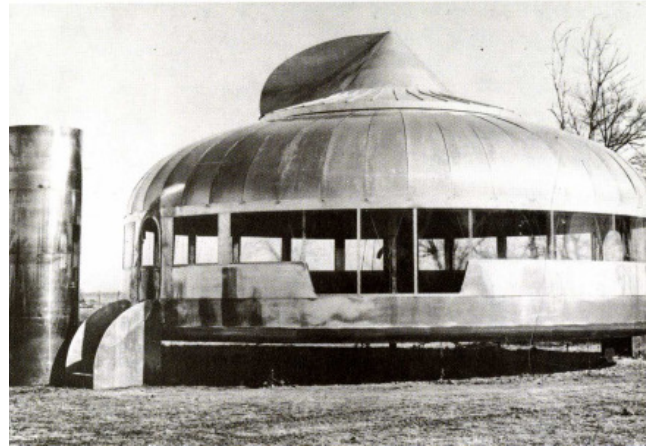
Comparisons between offsite building construction and car manufacturing persist because cross industry learning is commonplace. In an article about the history of Toyota car manufactures and the Sekisui house model, David Gann identifies the techniques shared between the two companies – Toyota's introduction to the concept of mass customization, and the Sekisui house model's development of component standardization and cataloging, quality control techniques, and technology integration (1996, 447). It can be argued that buildings are even sold like cars; they have features that raise market value, and are comprised of parts that can be removed, traded-in, and upgraded to further extend building life expectancy. The marketing strategy for Buckminster Fuller's Wichita House employed this strategy. Because the house was fully demountable, the entire building could be upgraded when new models were created (Burns 2001, 52). Historically in manufacturing processes, modifications to



components slow the assembly line process, contributing to increased production time and costs. Therefore, like any manufacturing process, the trade-offs to using offsite construction instead of stick built construction include increased pre-planning for reduced construction duration, higher craftsmanship with the reduction of joints, reduced material waste with the standardization of components, and greater life cycle value with the ability for an assembly to be demountable.

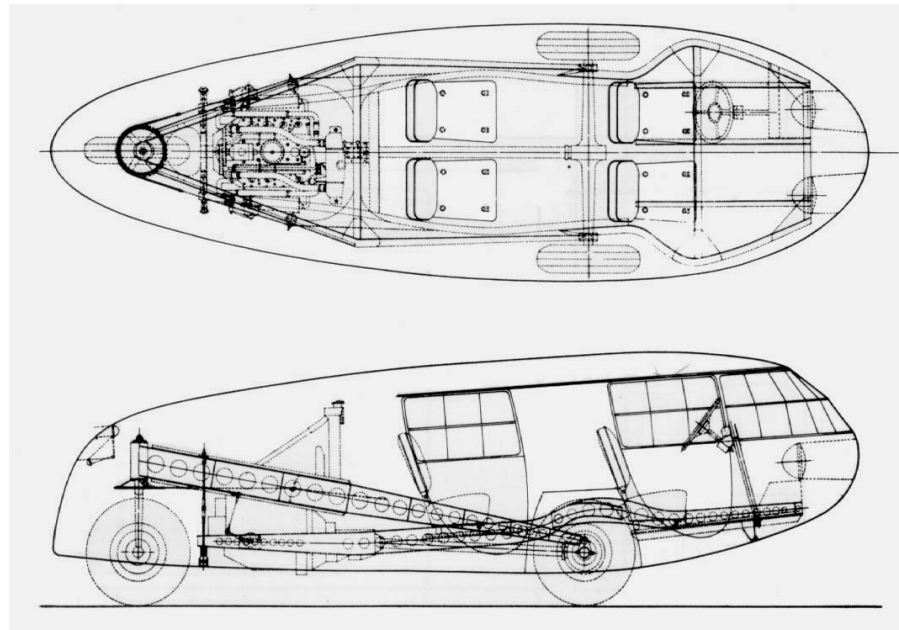
## 2.5 Innovation in Computer Aided Design

The contribution of technology to offsite manufacturing processes is expected to be considerable, yet it is unknown to what extent manufacturers are employing these tools in their processes. Prototype design demands highly detailed drawings because, as stated by David Denison of the Ohio Board of Building Standards, “it is one thing to have a dangerous condition in one house, and another to have it repeated a thousand times in an industrialized unit” (Burns 2001, 52). This requires the full modeling of components to effectively prove that all elements fit together with acceptable tolerances and sufficient detail (Kieren and Timberlake 2004, 115). With the emergence of Building Information Management (BIM) tools, schedules and engineering data can be passed between consultants seamlessly, and joint details can be instantly modeled in 3-D. Computer Numeric Control (CNC) milling machines, 2-D laser cutting devices, and 3-D full scale printing procedures can remove hand craft completely from the manufacturing process, eliminating the interpretation of



*Figure 2.4.1 (top) Witchita House by Buckminster Fuller (Arieff 2002, 17)*

*Figure 2.4.2 (bottom) patent drawings for Buckminster Fuller's Dymaxion Car: Three prototypes were built total (Fuller and Marks 1973, 49).*



drawings by the different design and construction disciplines.

The advancements of technology most associated with building construction include the use of innovative building materials, internet based purchasing, 3D-CAD, computer aided manufacturing (CAM) tools, and computer aided engineering (CAE) simulation tools. 3D-CAD software enables modeling with built-in databases that store building information (product information, assembly groups, dimensions, etc.). 4D-CAD software additionally stores scheduling and construction sequencing information, while 5D-CAD incorporates cost data (CADeshack 2009). The depth of building information modeling allows compact data files to be passed seamlessly between designers, engineers, contractors, manufacturers, and clients. CAM tools today can pass building information directly between the designer and the machine, eliminating the chance for human error. For example, the aim of a system like D-Shape, being developed by Monolite, is to construct inhabitable space without involving any human intervention (Monolite UK 2011). Similarly, *Contour Crafting*, a robotic arm concrete pouring system being developed at the University of Southern California, can produce a 30 foot slab on grade, and, with the foundation in place, the machine can erect detailed concrete walls that include omissions for door and window fabrications (“Robot Crafted House” 2006, 20). CAE simulation tools like Autodesk Ecotect Analysis, used for studying the energy performance of buildings, and SAP 2000, used for structural analysis, interface

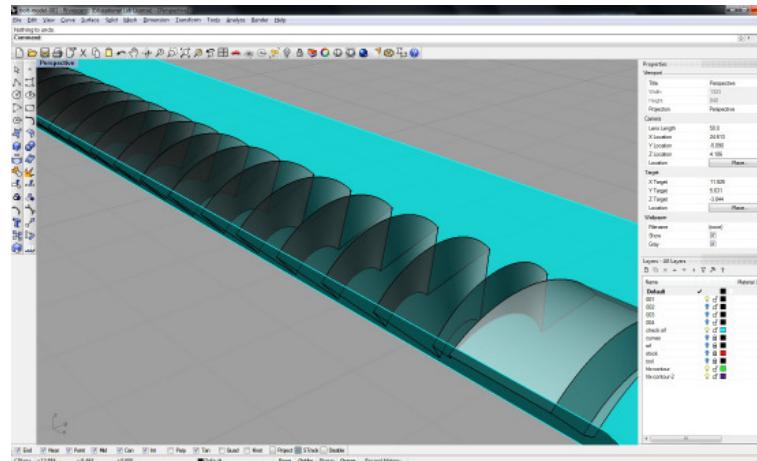


Figure 2.5.2 Rhino 3-dimensional model

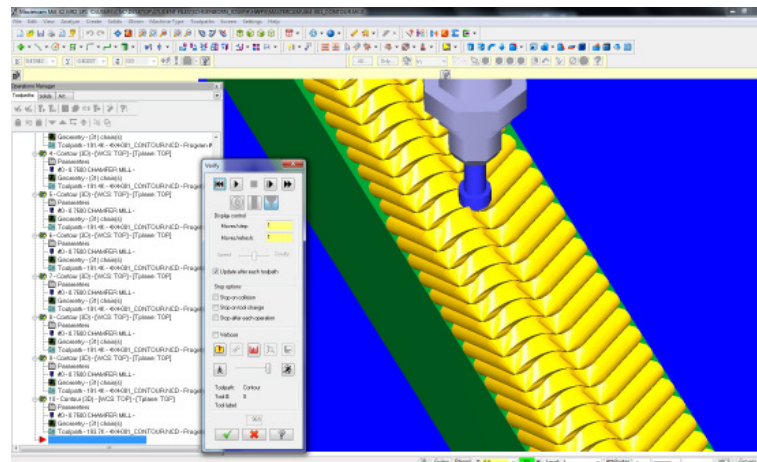


Figure 2.5.1 MasterCAM X2 model



Figure 2.5.3 CNC-milled 4x4: Object created by a 3-axis CNC router, using the surfaces modeled in Rhino to define the toolpath boundaries in MasterCAM.

with 3D-CAD tools. Eventually, a heightened accountability among disciplines may be the biggest contribution computer modeling tools have to offer to building construction, because no longer are construction documents intended as diagrammatic representations with a complete disregard to how systems relate to one another in 3-D space.

**2.6 Architectural Precedents**

The Museum of Modern Art in New York (MOMA) ran an exhibition chronicling the history of offsite construction in 2008. Karrie Jacobs of *Dwell* magazine described the exhibition in her article “The Prefab Decade” as a history full of failed ventures in utopian design. She contributed this failure to architects’ refusal to compete with large-scale developers because of the unwillingness to mass produce design. Particularly in the residential building market, she argues though that prefabrication for architects isn’t about productivity, and has instead continued to intrigue architects as an opportunity to transform the “culture of architecture” (2007, 96-97). In truth, of the projects displayed in the exhibition, few prototypes have been successful in mass production. The most successful design in the U.S. (selling over 100,000 homes over a 40 year span) were the Sears Catalog Houses. Shipped as a house-in-a-box, the houses disguise all traces of their construction behind a thin veneer. The strategy is to produce a single family house at a competitive price that could instantly fit-in with current aesthetic trends (Bergdoll and Christensen 2008, 48). Conversely, innovative projects which assert

**SEVEN-ROOM COLONIAL**

**Honor Bill**  
**The Lexington**  
 No. P3255 "Already Cut" and Fitted  
**\$4,030.00**

**What Our Price Includes**  
 At the prices quoted we will furnish all the material to build this seven-room colonial house, consisting of:  
 Lumber, Lath,  
 Clear Red Cedar Shingles for Roof;  
 Siding, Curb, Cornice, Soffit,  
 Framing Lumber, No. 1 Douglas Fir or Pacific Coast Hemlock,  
 Flooring, Pine Floor, Clear Oak, except Kitchen and Entry, which are Clear Maple; Second Floor, Bath-Room, and Hall, Maple; Banister of Brown or Hali, Clear Oak, Aesthetic Dressing and matched Douglas Fir or Pacific Coast Hemlock;  
 Porch Ceiling, Clear Grade Douglas Fir or Pacific Coast Hemlock;  
 Finishing Lumber;  
 High Grade Millwork (see pages 108 and 109);  
 Interior Doors, Two-Cross Panel Design of Douglas Fir;  
 Trim, Beautiful Grade Douglas Fir, except Stair Treads, Newel and Rail, which are Birch;  
 Kitchen Cabinet, Medicine Case,  
 Colonial Back, Match Colonial Shutters;  
 Kitchen De Luxe Outlet;  
 Windows, Case with Clear White Pine;  
 Building Paper, Sheetrock, Wall Paper;  
 Level Trough and Drain Spout;  
 Necessary Fasten Hardware (see page 120);  
 Paint for Three Coats Exterior;  
 White Enamel for trim and Mahogany Stain, Shellac and Varnish for Doors,  
 Shellac and Varnish for Maple Floor,  
 Varnish and Wood Filler for Oak Floor,  
 Complete Plans and Specifications.  
 Built on a concrete and brick foundation and excavated under entire house.  
 We guarantee enough material to build this house.  
 Price does not include cement, brick or plaster.  
 Free descriptions of "Honor Bill" Houses on pages 12 and 13.

**Options**  
 Short Plaster and Plaster Finish, to save the place of most with \$272.00 extra. See page 142.  
 Tile floor in bathroom and entry, instead of maple, \$24.00 extra.  
 Screen Doors and Windows, galvanized wire, \$42.00 extra.  
 Original Graphite Shingles, guaranteed for 17 years, instead of wood shingles for roof, \$37.00 extra.  
 4-1/2" Wide Orange Asphalt Slate, Superior Street Shingles, guaranteed for seventeen years, instead of most shingles for roof, \$34.00 extra.

**FIRST FLOOR**  
 This house can be built on a lot 22 feet wide.  
 The Reception Hall. On entering, you pass through a colonial entrance, which has a quaint colonial door with side lights on either side, giving light and cheer. This reception hall connects through French doors to the living room on the left and the dining room on the right. Here, too, is a beautiful colonial stairway to the second floor, a door leading to the first floor lavatory, and a door connecting with the rear entry.  
 The Living Room. From the reception hall you pass through a pair of French doors on the left and enter the large living room, 13 feet 3 inches wide by 25 feet 3 inches deep, which has a real colonial fireplace. There are two windows in the front, a double window overlooking the flower garden to the rear, while a window on one side of the fireplace is balanced by a French door to the porch on the other. Ample wall space and floor area affords a wide choice of placing the furniture.  
 The Side Porch. Directly connecting with the living room is a large side porch, which is practically an outdoor living room during the summer.  
 The Dining Room. Retracing back to the hall to the right, you enjoy the dining room through a pair of French doors. Floor size, 13 feet 3 inches wide by 13 feet 7 inches deep. Two front windows and a double window on the side assure a cheerful atmosphere.  
 The Kitchen. A swinging door from the dining room leads to the well appointed kitchen. On the right

**SECOND FLOOR**  
 wall is our Kitchen De Luxe Outlet, illustrated on page 109. On the left wall is our built-in Kitchen Cabinet, also shown on page 109. Spaces for the range and refrigerator are provided for convenience and saving of effort. A double window on the side and a single window in the rear provide light and cross ventilation. A door leads to the rear entry, which has stairs to the basement, and a door to the stoop and grade.  
 The Bedrooms. A hall connects with each of the four bedrooms, linen closet, broom closet, bathroom, and a door that connects with a stairway leading to a large attic. Each bedroom has light on two sides with cross current of air and a good sized clothes closet. The master bedroom has room for twin beds, while in each of the other three bedrooms there is room for one bed and the usual furniture.  
 The Bathroom has one window, and a built-in medicine case.  
 Basement. Room for furnace, laundry and storage.  
 Heights of Ceilings. Basement is 7 feet from floor to joist. Main floor rooms are 9 feet from floor to ceiling. Second floor rooms are 8 feet 6 inches from floor to ceiling.

For prices of Plumbing, Heating, Wiring, Electric Fixtures and Shades see pages 140 and 141.  
 4205 Ingham St. Washington, D. C.  
 Sears, Roebuck and Co.  
 Gentlemen: I am the purchaser of one of your "Honor Bill" Houses, "The Lexington." I am a local builder having built a number of homes of local material. I take pleasure in recommending your excellent A-1 quality building material that you furnish and your quick attention to your customer's needs. The ready cut idea reduces labor costs, I saved from \$1,000.00 to \$2,000.00. Very truly yours,  
 FRANK E. BRUNN Contractor and Builder

This house can be built with rooms reversed. See page 3.  
 For Our Easy Payment Plan See Page 146

SEARS, ROEBUCK AND CO. P302 Page 21

Figure 2.6.1 a Sears Roebuck House of the 1920's (Small Houses of the Twenties 1991, 21)

themselves as homes for the future, like Buckminster Fuller's Dymaxion House, never left the prototype phase.

### 2.6.1 Prototyping

The Dymaxion House (completed as a one-off built house named the Wichita House) was designed as a transportable kit that could be suitable for any building site. The geodesic dome of the house covers the maximum amount of space with the smallest amount of material possible. The façade is clad in repetitive aluminum panels, and the interior space is divided radially around a central mast structure (Koch 1958, 78). It can be argued that the Case Study House Program (started in 1945 by *Art and Architecture Magazine* edited by John Entenza) was an example of prototyping at the scale of a completed home. The intent of the program was to challenge the construction process by introducing a range of prefabrication components for custom buildings; the final outcome could have been marketed as a mass produced commodity (Bergdoll and Christensen 2008, 95). Although it was ultimately viewed as an educational exercise, trying to push what is possible in single family house design, the Make It Right program being implemented today in New Orleans is being realized at a large scale. The homes designed for the program provides clients a range of pre-designed houses to choose from.

### 2.6.2 Processed Materials

Frank Lloyd Wright's Usonian Houses are all unique, simplifying design by using standard details and economies of scale to reduce



*Figure 2.6.1.1 Case Study House #22, the Stahl House, by Peter Koening (Smith 2007, 68)*



*Figure 2.6.1.2 Garden Prototype by KierranTimberlake Architects (KieranTimberlake 2007)*

costs. Finish work is arguably the most labor intensive part of construction, and an effective use of prefabrication would ideally limit the amount of precision work needed to be done onsite. The board and batten system was designed for shell construction using the natural wood finish on the interior and on the exterior, thus eliminating the need for labor-intensive plaster finishing. Wright further reached into componentized design with the Usonian Automatic Building System (UABS) in which the plan grid aligned with the grid of the shell's textile block construction. The intent was for houses to be self-built by the individual client, as executed by the Adelman House in Arizona (Morse-Fortier 1994, 277).

### 2.6.3 Prefabricated Components

The 3-dimensional components in Shigeru Ban's Furniture House are not inhabitable spaces. The OSB-clad floor-to-ceiling shelving units are used to divide the spaces within the house, but they also serve as the primary structural elements of the house. Five different projects were completed by Ban. The 'furniture' components are used both as shelving and closet spaces, and they free the shell of the building from structural burdens, instead allowing it to be responsive to its surroundings (Bell 2001, 45). The idea actually was conceived as a response to site conditions; earthquake casualties in the home are often a result of victims being trapped by furniture falling over, so Ban instead uses built-in furniture. His Paper Log Houses were also made reactionary to extreme site conditions – used for quick disaster relief shelters. Built on a

crate/palette foundation, the walls are made of paper tubes (wrapped in a waterproof sponge tape with an insulated backing), and the roof of a tent material. The units are demountable and the materials are easily recyclable (Matilda 2003, 36-38).

As discussed previously, the Sears Catalog Houses (and similarly, IKEA's Bo Klok homes) was comprised of prefabricated components, but it was designed to hide, not celebrate their construction. In Taylors Island, Maryland, the Loblolly House designed by KieranTimberlake Architects (KTA) similarly uses site-installed siding to finish the building, but the design deliberately celebrates its small impact on the construction site. The building site is located in a fairly dense forested area near the water, and the building's orientation and its attachment to the site reflect the building's desire to fit in to its surroundings. The house is built on a wooden pile foundation to both minimize excavation and to elevate the house above the site's flood plain. The architects designed a series of factory built components including "smart cartridges" for the floors, ceiling and roof, "dumb cartridges" for the skin, and modular mechanical and bathroom "blocks." 30 percent of the overall construction work was required to be done onsite, though the architects believed that if the house was mass produced, that figure could easily be reduced to 15 percent (Clifford 2007, 147). Of the few elements that were built onsite, the pile foundation, which expresses the light connection to the site visually, and the vertical cedar plank siding, which aesthetically camouflages the building in the dense loblolly

pine forest, both visually display the conscious sensitivity the construction process had to its impact on the site.

Oskar and Johannes Kaufmann, partners in the firm KFN, have developed a heavy timber frame that produces a 3-dimensional structural matrix in which the envelope – a panel composition selected from a library of opaque, transparent, and partially transparent panels – can be bolted directly to providing a higher level of customizability. Renzo Piano's IBM Traveling Pavilion consisted of a demountable laminated wood frame infilled with a multitude of clear polycarbonate pyramids that are also bolted directly to the structure to create the envelope. While acting as the thermal envelope of the building, the polycarbonate pyramids play a role in the cross bracing of the semicircular truss elements. These prefabricated components could be transported in compact form (stacked in a nested fashion), and were light enough to be handled and assembled by a manned crew (Dini 1984, 79).

### 2.6.4 Panelized Structures

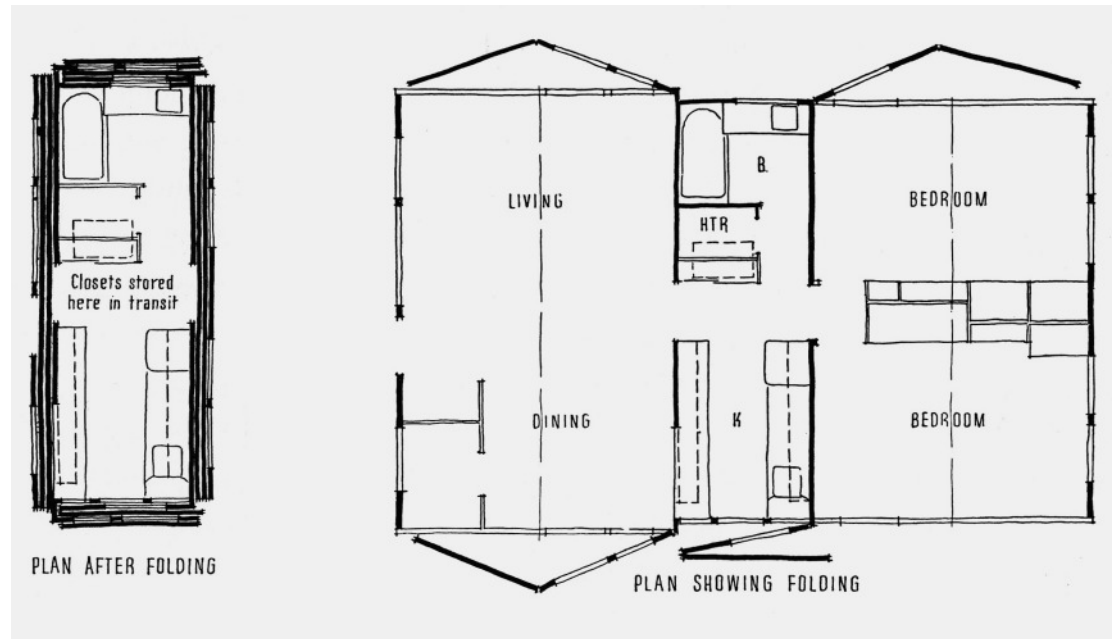
SIP (Structurally Insulated Panels) components were designed to eliminate thermal bridging concerns prevalent with lightweight timber construction by using a continuous sheet of extruded polystyrene adhered and sandwiched between two sheets of 3/4" OSB plywood. Structurally, they provide lateral stiffness between parallel columns or beams. In the Cantilever House by Anderson Anderson Architects, a steel vierendeel truss is used as the pallet for the SIPs that comprise the walls,

the floor, and the roof. Due to the material composition of the SIPs, the same panels are used for the roof as those used for the walls, giving the building envelope continuity in its aesthetic only broken by the introduction of glazing elements (Anderson 2006, 114).

Carl Koch's Acorn House introduced a transformational element to its design. The central utility core was built on a steel chassis, and could be transported to a site on the flatbed of a truck. Attached to the core was a panelized skin that rotated on hinges, allowing the exterior walls, floors, and roof systems to fold out and create the living functions of the house – bedroom, dining room, and living room. The core contained the bathroom and kitchen functions. Although Koch experimented with the idea of a demountable foundation, a permanent concrete foundation was poured onsite elevating the steel chassis slightly off of the ground (Koch 1958, 84-85). The use of helical piles that can be retracted and reinserted at a new location were not yet developed. The ZeroHouse by Spect Harpmen effectively uses helical piers, resting on a steel chasses attached to the piles requiring no excavation at all (Herlitz 2008, 66).

### 2.6.5 Modular Structures

Habitat 67 (a residential complex built for the 1967 International and Universal Exposition in Montreal, Canada) by Moshe Safdie successfully internalizes a suburban condition in an urban context. The complex is an arrangement of a series of identical precast concrete volumes fit together in a number of



*Figure 2.6.4.1 Acorn House by Carl Koch: ships as one volumetric module, with a hinged panelized system to save on transportation costs (Koch 1958, 91)*



*Figure 2.6.4.2 Acorn House foundation installation: The steel chassis sub-floor structure rests on a cast-in-place concrete pier foundation located directly beneath the central core (Koch 1958, 93).*

different arrangements to create a monolithic landmark for the city. Using about five different shaped module structures, each living unit (with a private garden) commands its individual presence despite the compact nature of the cluster of modules because of the interstitial spaces created by staggering their layout. Communal spaces including parks, shops, and even movie theatres are dispersed through the complex (Safdie 1970, 11-12).

Modular construction would seem to be ideal for urban infill sites because onsite construction can be completed in phases allowing the surroundings buildings to be relatively undisturbed. The challenge, however, is that high-value “flagship projects” like large office developments would be undermined by the introduction of the limitations of modular construction (Hartley and Blagden 2007, 67). But, though by no means prevalent, the challenge is being undertaken today by large architectural firms like SHoP Architects (Atlantic Yards in New York), or O’Connell East Architects (Victoria Hall in Wembley, UK). The New York based firm Lot-Ek, in particular, pushes the re-use of shipping containers as modular building blocks in urban environments. With their Container Kit project, complex building systems were divided into volumetric forms that protruded from the base container footprint, but could be pushed in to form a compact, transportable unit. The components contained different room functions – bathroom, kitchen, etc. In compact form, the building

remains a standard container size (Herbers 2004, 139).

The Sub-Urban House by Resolution 4: Architecture was produced for an invitational design competition hosted by the magazine *Dwell*. It is located on a steeply graded site in North Carolina. The finished room components were delivered onsite by four separate trucks and set on a cast-in-place concrete matt foundation (Arieff 2004, 123). The mechanical systems for the house were embedded within the foundation. An assortment of different components was designed to provide countless configuration possibilities making the building easily adaptable as a customizable product. The onsite construction proved to accumulate the most delays and added expenses to the project – the cost of production of the modules was more than \$1,500 over its initial estimate – because of unpredictable weather and unexpected site conditions (Arieff 2004, 123).

## 2.6.6 Manufactured Homes

Manufactured home construction can be most easily compared to automobile manufacturing because they are completely constructed in the factory. Mobility by definition implies that the house is expected to be fully demountable and change its location easily. While not all mobile homes are built on demountable foundation, the record of the house’s existence on the site is minimal and would be adaptable to new construction (or a new model of the same building). Architect Tim Pyne’s M-House is one such building that maintains its mobility, and was designed to be moved around for use as a vacation homes at temporary locations; it can be installed in an open field, float on the water, or sit atop the roof of a skyscraper. The house is divided into two parts which are connected within hours, which the compact interior relies heavily on built-in furniture to increase the amount of open floor space (modeled after ship cabin design) (Herbers 2004, 76-78).



Figure 2.6.5.1 Container Kit home by Lot-EK (Lot-EK)



**Figure 2.6.5.2** rendering of O'Connell East Architect's and CTZWG's Victoria Hall: a 19 story student dormitory building to be located in Wembley, UK (OCA).



**Figure 2.6.5.3** rendering of SHoP Architect's B2 Brooklyn Building for Atlantic Yards: standing at 32 stories, the New York building will be the tallest prefabricated steel structure to date (SHoP Architects).



## 2.7 Reaction to Literature

Major architects throughout the twentieth century have tried to develop prototypes for mass production with little success – Le Corbusier’s “La maison standardisée,” Buckminster Fuller’s Dymaxion House, Frank Lloyd Wright’s Usonian Automatic Building System, Walter Gropius’s Copper Houses, etc. (Kierran and Timberlake 2007, 104). Yet today there appears to be a renewed interest in the integration of prefabrication and preassembly to improve quality and to save time, particularly in the commercial building sector. The emergence of BIM as the preferred design tool of architects has helped to highlight the potential benefits of a manufactured building process. BIM strengthens the architect’s role as the “master builder,” bringing construction and scheduling conflicts to the forefront early in the design process. Furthermore, from a research perspective, the opportunities for manufacturers to adopt some of the automated construction techniques seen in the automobile or airplane building industries has drawn the interest of architects to the modular building industry with the desires to increase labor productivity and craftsmanship while investigating the use of complex building components and cutting-edge materials.

Several studies over the past 10 years (those done by Lu Na, McGraw Hill Construction, Carl T. Haas, etc.) have identified the amount of pre-planning, project coordination, transportation restrictions, and procurement/scope of work concerns as the primary limitations of modular construction. Collecting

the opinions of architects, engineers, onsite general contractors, and building owners through both interviews and surveys, these studies predominantly considered the cost effectiveness or business model alterations that could improve the efficiency of onsite construction. This study instead focused on the design and coordination issues that arise specifically through the interactions of the architect and modular manufacturer for a project that would be predominantly built in a factory, providing an understanding of what different modular manufacturers identified as general concerns, and what might be specific to their type of building process or strategy.

## **CHAPTER 3: METHODOLOGY**

### **3.1 Overview of Qualitative Research Methods**

This study used qualitative research, and specifically a grounded theory methodology, to uncover the primary issues considered to be constraints or barriers to the industry's ability to build innovative design projects. Quantitative methods use empirical data (data acquired by means of experimentation) collected to support a proposed research hypothesis. Qualitative research emphasizes the influence of the researcher on the data collected. Instead of interpreting data objectively without bias, the researcher's background and point of view play into the presentation of the data and the structure of the investigation (the questions asked, and the level of interaction with the subjects) (Groat and Wang 2002, 88). Qualitative research seeks the answer to "why" by obtaining unstructured data, while quantitative research is occupied with "how" using numerical and statistical data. The purpose, therefore, is to shed light on a subject's attitude, behavior, values, concerns,

motivations, aspirations, or culture (Groat and Wang 2002, 173-175). Grounded theory methodology makes the development of theory reactionary, uncovered after data analysis. It operates in an opposite manner from the scientific method where a hypothesis is posted, tested, and then proven either to be correct or incorrect. Instead, it involves the collection of data, followed by the subsequent coding and grouping of data into concepts that a theory can be based upon (Allan 2003, 1-10).

#### **3.1.1 The Case Study Design**

This study was designed using case study as a tactic. Originating from the social sciences, the case study methodology is defined as an in-depth description and analysis of a single entity or phenomenon (the case). It can be either descriptive or explanatory, using any manner of data collection procedures (Yin 1984, 10). The cases can be used to encompass a program, an event, a process, an institution, or a social group (Creswell 2009, 12). As a qualitative research method, the emphasis is

**Table 3.1.1.1** assumptions of qualitative design: the following examples from the research illustrate the qualitative paradigm assumptions (Creswell 2008, 179)

Assumption	Question	Quantitative	Qualitative
Ontological Assumption	What is the nature of reality? <b>Design innovation is subjective.</b>	Reality is objective and singular, apart from the research	<i>Reality is subjective and multiple as seen by participants in a study</i>
<i>Epistemological Assumption</i>	What is the relationship of the research to the researched? <b>The discussion combined the collective experiences of the participants as construction specialists and the experience of the researcher as a designer of the case study project; each with their own opinions as to what constitutes innovation.</b>	Researcher is independent from that being researched	<i>Researcher interacts with that being researched</i>
<i>Axiological Assumption</i>	What is the role of values? <b>The reactions/opinions of professionals as to the feasibility of a hypothetical project featuring an innovative approach to a prefabricated system were recorded.</b>	Value-free and unbiased	<i>Value-laden and biased</i>
<i>Rhetorical Assumption</i>	What is the language of research? <b>The data collected in this study was presented as a narrative.</b>	Formal Based on set definitions Impersonal voice Use of accepted quantitative words	<i>Informal Evolving decisions Personal voice Accepted qualitative words</i>
<i>Methodological Assumption</i>	What is the process of research? <b>The research uncovered the variables that negatively affect design innovation, and both internal and external verification strategies were employed.</b>	Deductive process Cause and effect Static design – categories isolated before study Context free Generalizations leading to prediction, explanation, and understanding Accurate and reliable through validity and reliability	<i>Inductive process Mutual simultaneous shaping of factors Emerging design – categories identified during research process Context bound Patterns, theories developed for understanding Accurate and reliable through verification</i>

on process and discovery, instead of results and accuracies (Creswell 2009, 5). The intent is to provide a comprehensive stat of the case (its feasibility).

Lois-ellin Datta divides case study research into six different types: illustrative, exploratory, critical instance, program implementation, program effects, and cumulative (Datta 1990, 37). An illustrative case study is a descriptive study that depicts what a situation is like, familiarizing the audience with a topic that there is too little information available about (Datta 1990, 37). An exploratory case study is a condensed process that researchers usually undertake as a part of a larger study; it helps identify questions and select measurement constraints in order to serve as the introduction to a larger investigation (Datta 1990, 42). A critical instance case study is a detailed examination of one instance, and is used to either examine a situation of unique interest to the researcher, or to test the validity of a universal assertion (Datta 1990, 47-48). A program implementation case study can help discern whether or not an instance is in compliance with its design intent; it is often used when concerns presently exist about a program (Datta 1990, 50-51). A program effects case study is used to determine the impact of a program and the reasons for its success or failure (Datta 1990, 56). Finally, a cumulative case study brings together the findings of multiple case studies, using either a retrospective or a prospective tone, as a means to aggregate findings and prevent repetitive analyses (Datta 1990, 59).

The approach to this study primarily fits into the explorative case study method. The ultimate purpose was for this to be part of a larger study. Suggestions for further investigation into the topic of innovation in modular construction are identified in a later chapter. In the end, however, the data collected was largely geared towards providing a tool for the education of architects which also makes this study an illustrative case study type. There is an underlying need for information to be provided that identifies the constraints and barriers to design innovation. Only when the design challenges and technical limitations of modular construction are understood, can solutions be pursued.

### 3.1.2 Role of the Researcher

In this study, I acted as the sole researcher who contributed to the design of the hypothetical project and was responsible for gathering information from modular manufacturers. The case being investigated is an example of an innovative modular building project. The program is the external classroom – an education facility that would ideally incorporate mass customization techniques to fabricate an array of unique building components. The program requirements were introduced through a graduate level interdisciplinary studies course. In the class, the designs for 20 sustainable, temporary, re-usable, and affordable classrooms for an urban environment were proposed. The challenge was extended to students from different disciplines (architecture, landscape architecture, and building construction). The project pushes innovation by programmatically

accommodating the need for education facilities to be adaptable and evolutionary (in their support of teacher's needs, in the increasing expectations of students, and in the growth and expansion of technology).

The following design strategies for modular construction were encouraged through the class to increase quality without increasing initial building costs:

- Standardization of components (ie: reproduction of component and joint details)
- Reduce number of joints (light tool usage) to increase onsite craftsmanship
- Reduce component shipping numbers and shipping weight (less than 3000 lbs)
- Reduce electrical complexity with a plug and play lighting system
- Minimize duct sizes and length of runs (distributed systems, not central AHU unit)
- Minimize the amount and the complexity of work done onsite (foundation pre-work and onsite preassembly)

Following the completion of the course, a set of drawings that adequately represent the design goals and the construction details of the project were produced for distribution to the professionals from the modular building industry participating in the research.

### 3.1.3 Ethical Considerations

This explorative case study was designed to contribute to generalized knowledge, and

because the research involved the interaction of individuals, the safeguard of sensitive information is an ethical requirement. To protect the rights of participants, the following procedures were followed:

- 1) The research objective and process were made clear to the participants.
- 2) The data collected was used for the research objectives only.
- 3) Only data collected from consented participants has been included.
- 4) Data recording methods were made known to the participants.
- 5) The written transcript of interviews, and the data analysis were all made available at the request of the participants.
- 6) The anonymity of the participants was maintained.
- 7) Institutional Review Board (IRB) approval was obtained before data collection and after data analysis.

### 3.1.4 Setting

The study was conducted both remotely for interviews conducted over the phone, and at the plants of manufacturers for interviews conducted face-to-face. Conducting the interviews at the plants provided the opportunity to observe production processes and the organizational structure of the companies, adding a visual and immersive component to the data. Alternatively, in the interviews conducted remotely, the production processes of the companies was not explicitly known, and all the data collected is based on the responses

to the questionnaire and the discussions that follow.

### 3.1.5 Actors

Five building manufacturers were interviewed. Two interviews were conducted at the factories of the manufacturers, and three interviews were conducted remotely over the phone. One of each was required at the minimum for internal validation. Interviews were done in pairs, providing the opportunity for data to be reviewed for external validation. Duplicate participation levels were used in order to collect detailed data.

The representation from modular manufacturers in the interviews included the following participants: construction managers, billing or finance specialists, and building code research specialists. Group interviews were intended to facilitate the discussion, and to include professionals familiar with all phases of the manufacturing process. The effectiveness of this study is ultimately dependent on the collaboration of participants who share an interest in innovative construction practices and whose goals coincide with the perceived benefits of offsite construction – waste reduction, parallel work, labor productivity and safety, quality control, construction time and cost savings, and the overall reduction of the environmental impact of buildings. Modular manufacturers sought for participation employed varying fabrication techniques, and affiliation with the Modular Building Institute and Virginia Tech were used to aid in the search for participants.

### 3.1.6 Events

This study used interviews as a method of recording the reaction of manufacturers to an innovative design proposal which incorporates offsite construction (the case study project). The questions asked were open-ended, and the interviews were one-time group interchanges.

The advantage of group interviews, best described by Norman K. Denzin and Yvona S. Lincoln, is that they can either “aid respondents’ recall of specific events or ... stimulate embellished descriptions of events or experiences shared by the group” (2000, 651). This is beneficial because the experience of the individuals is expected to play a role in their answers. However, there are disadvantages to this approach, and Denzin and Lincoln make a series of suggestions to keep the interviews bounded: 1) prevent one person from dominating the discussion, 2) encourage reluctant individuals to participate, and 3) make sure each individual has the opportunity to speak on each topic (2000, 652). Therefore, the conversations needed to be fluid and sometimes improvised.

The difference between structured and unstructured interviews is that structured interviews are completely scripted, whereas unstructured interviews require little more than an objective (Denzin and Lincoln 2000, 649). This study employed an identical set of pre-determined questions asked to all participants, but the participants were all given the opportunity to ask questions, and the conversations were encouraged to evolve. The

topic of discussion (the hypothetical project) was sent to participants before the interview process so that their reactions were given time to mature.

### 3.2 Data Collection Tactic

The interview as a research tactic is designed to capture the reactions of industry professionals to whatever topic is presented to them. The validity of their responses as data depends on the credibility of the interviewee. This can be based on his or her experience, and on the ability for the responses to be corroborated by other evidence. The challenge is that interviews ultimately call for recollection, which can lead to inaccurate information (particularly for dates), or to information relative to a specific area, specialization, or context. Recollection can also lead to inferred data, referencing specific facts pertaining to prior actions or activities. Therefore, it should be understood that conclusions made from studies using interviews as a data collection tactic are essentially an “interpretation of an interpretation” (Groat and Wang 2002, 159).

#### 3.2.1 Development of the Questionnaire

The interview questions asked during the two face-to-face interviews included both questions specifically referencing conditions in the case study project, and general questions about the manufacturer’s process and the state of the industry. Questions about the project covered the following topics:

- 1) The feasibility of the components to be fabricated in-house

- 2) The ability for component production to utilize some form of automation
- 3) The marketability of the project

The more general questions encompassed the following topics:

- 1) The fabrication process of the plant
- 2) Perception of the industry in the eyes of the architects and the consumers
- 3) Whether or not life cycle costs are factored into building estimates
- 4) Transportation risks and limitations
- 5) The interface between the offsite production of components and their installation on-site
- 6) The role of BIM in the manufacturing process
- 7) The extent of a modular manufacturer’s involvement in building design

The next two phone interviews were shorter in duration and focused on the manufacturers’ processes. The questions asked were not identical because some of the manufacturer’s capabilities were known ahead of time. Yet there was still a considerable amount of overlap in the data obtained from the two interviews. The topics covered in the two conversations included the following:

- 1) The extent of a modular manufacturer’s involvement in building design
- 2) General design considerations that are unique to modular construction
- 3) Reasons for shop drawings to be produced as a supplement or a replacement to

- construction documents
- 4) The inspections process in the factory
- 5) The role of BIM in the manufacturing process
- 6) The level of automation used

The final phone interview was the shortest and was conducted specifically for the purpose of identifying another modular manufacturer that is using automation in their factory. The purpose was to confirm some of the information gathered from a prior interview. The following topics were covered:

- 1) A list of the CNC controlled machines used in the factory
- 2) The role of BIM in the manufacturing process and the program used
- 3) General design considerations that are unique to modular construction
- 4) The level of control the manufacturer has over design and onsite construction

#### 3.2.2 Data Recording Procedures

The process for face-to-face interviews was conducted in three steps. The project drawings and details were first distributed to the participants before the interview. Factory tours followed, providing a detailed understanding of the manufacturers’ production processes. The interviews themselves opened with reviews of the project so that the design intent was understood, and predefined questions were asked wherever they were seen as relevant to the discussion. For example, an excerpt from one conversation provided the following type of data:

“**Q:** *Design innovation in this particular project is largely attributed to the ability for the building to be customized based on a standard set of parts. With smaller panelized components shipped onsite, a greater amount of onsite assembly is required as compared to using larger complete modules. From an economic feasibility and overall craftsmanship point of view, is there a recognizable difference in the advantages and disadvantages to component sizes being designed for use?*

**A:** I don't know that there is an advantage of one over the other; comparing whether more can be done in the factory as site work is taking place versus shipping pre-cut materials to the site and having them assembled there. In terms of time savings, the more you can do to a point in the factory you can get more time savings in the overall construction process. ”

While there were no directions on the structure of the discussion, all key questions were asked regardless of their order. The interviews were recorded and transcribed at a later date (full transcriptions are provided in *Appendix B*). During each interview, only generalized notes were made at the researcher's discretion. The face-to-face interviews were conducted immediately after the participants agreed to be involved in the study.

The subsequent phone interviews were conducted at a more leisurely pace – spread out over several weeks. Consequently, the

questions asked were not identical, but reactionary to the information already obtained. Instead of a presentation of the design project, the interview sessions shifted to a direct Q&A format. Although the project drawings and details were distributed to the participants ahead of time once again, few of the questions asked addressed the specific feasibility of the project. Instead, questions focused on the capabilities of the manufacturers' plants, and their building processes. An excerpt from one of phone interviews follows:

“**Q:** *What is the greatest barrier to the concept of mass customization...?*

**A:** ... There is a huge disconnect between the software that are designing the thing (whatever it is, be it Revit or SolidWorks, or Grasshopper which is the ultimate mass customization tool), and the software that are involved in programming the robots, (which are usually quite disappointing). Now, I haven't seen the full range, but whenever you are buying this advanced machinery you have to balance the machinery with what the software is as well. Like the Ring of Fire (the automated steel cutting machine) was the worst scenario. [It was] like an Excel chart calculator really. So with the robots, even if you wanted to move the steel by 1/8 of an inch, or something like that which is only a fraction, you had to write a whole new program for software with checks to verify the coding. So you had to write a new program anytime there was something

different, and to the architectural world 1/8 of an inch is not really different ... ”

### 3.2.3 Data Analysis Procedures

In the end, a comprehensive list of the potential challenges that present themselves during the manufacturing process was compiled. Because unstructured data were collected, matching and opposing arguments were discerned from patterns in the responses of participants. The nature of the data collected from open-ended questions resulted in a large volume of information, therefore data analysis and interpretation occurred during the interview process. Data coding is common in qualitative studies in order to divide the information into themes or categories (Creswell 2009, 154). Therefore, data was organized and sorted by the frequency in which themes are repeated. Participants' individual and company names were also coded (numerically based on the chronological order of the interviews) to maintain confidentiality and organization. The final form in which the data is presented was determined by the nature of the results

### 3.2.4 Data Coding

The interview processes resulted in a large amount of data, including the notes taken during each interview and the written conversation transcripts. The task of managing data involved a coding process in which information is reduced and organized into “chunks” (Groat and Wang 2002, 193). The data can then be sorted by theme for direct comparisons. Traditionally, keywords like “innovation,” “design constraints,” or “barriers” would be sought out

so that pertinent information can be isolated, but the interviews themselves were semi-structured, so the responses were easier to compare directly.

The same questionnaire was not presented to all five participating companies, but the themes explored were consistently repeated so that second and third opinions could be gathered. The questions prepared were based on both previous studies noted in the literature review, and the experience gained from the design and development of the case study project. Each different stakeholder also came into the interviews with their own agenda – wanting to highlight what challenges they have experienced in constructing modular buildings, what practices they felt their company was particularly good at, or what they are doing that is different as compared to other modular manufacturers.

The interviews conducted were done in so that modifications could be made to the questions for better results. For example, not much of what was said in the earliest interviews stood out as evidence disputing or expanding on prior literature, so a slightly different approach was taken in later interviews. Specific questions about the case study project were abandoned, and questions instead focused on the use of technology in production. The data collected ultimately did not identify specifics on the feasibility of the case study project, so the analysis therefore encompasses more general topics about modular construction.

### **3.2.5 Verification**

Internal validation was measured by comparing the results of the two contrasting interviewing techniques – one being an immersive study where the experience of the building process is part of the interview story, and the other being a detached discussion where the participants and their answers are separated from the building process. For external validation, the interviews were done in pairs, and the data compiled in previous interviews was reviewed in the next set of interviews. Some of the data collected from the previous interviews were reviewed in the final interview to see if the inferences were accurate or if the manufacturer noticed anything was missing from the data collected to that point. Any new data introduced were included in the final report.

### **3.2.6 Reporting and Findings**

The information in this study is presented as a narrative. Since data collected came about through conversations with modular manufacturers only, the perspective of the architect was covered by the researcher. My intent was to relay everything that I learned about modular construction throughout the course of the study. The objective is for this to be a tool primarily for design professionals that can help them to understand the challenges unique to modular building design. Summaries of all five interviews follow, and the conclusions enclosed contain the opinions of all involved in the study based on their experience in the industry.



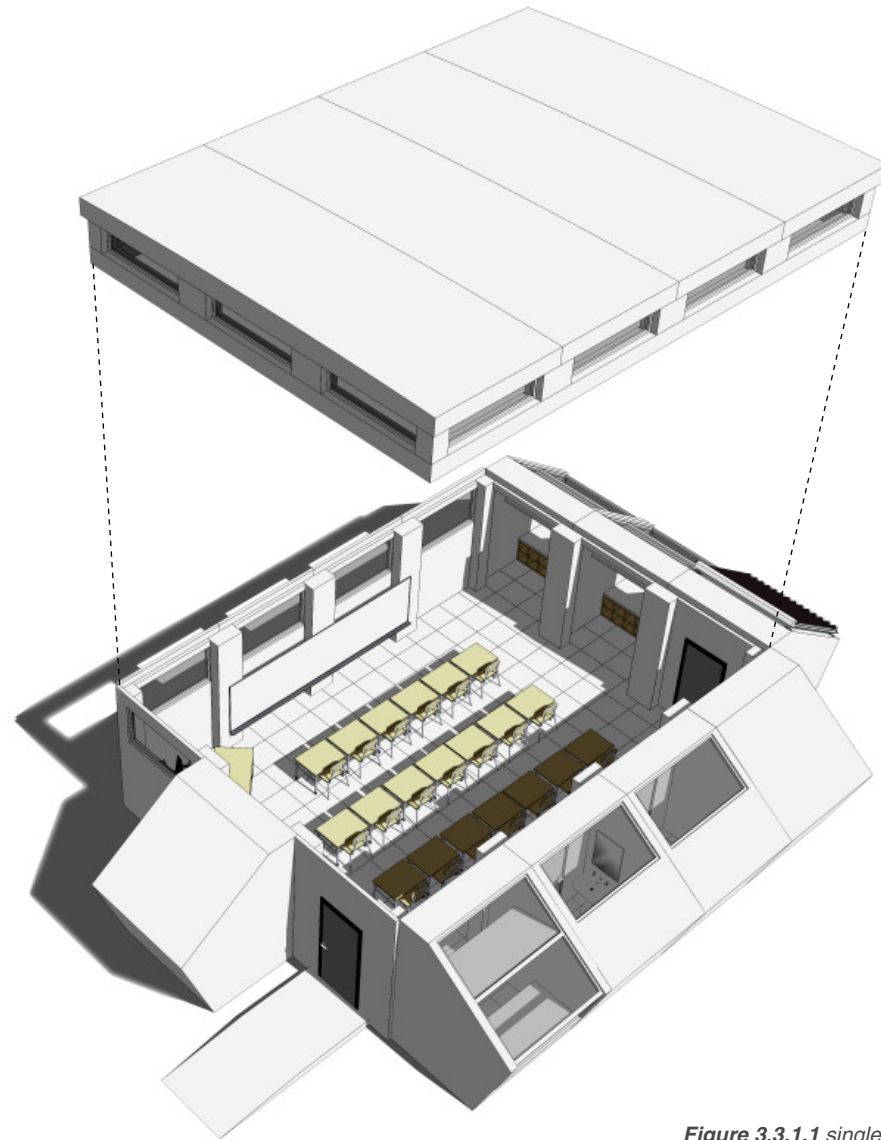
### 3.3 The Case Study Project

The complete drawing package provided to participants is located in *Appendix A*.

#### 3.3.1 Program

School districts currently need detached classrooms built for the permanent expansion of existing schools, the temporary displacement of students during school renovation projects, and the immediate replacement for schools hit by natural disasters. The facilities commonly used are selected because of their immediate availability and their proven affordability in both initial construction and operational costs. Persistent administrative issues, however, present design challenges for the building program. Annandale High School in Virginia, for example, currently has 29 external classroom facilities because of overcrowding. The facilities lack restrooms, they require additional supervision, and they are not suitable for all weather conditions (Barwick and McGarey 2001, 2). When they do meet the physical demands of the school, they do little to inspire or support creative thinking and mental growth – intangible program requirements that are easily overlooked. Approximately 3.15 million students are taught annually in external classrooms, encompassing both grade school and college level applications (MKThink 2004, 1).

The facility designed for this case study is comprised of an assortment of components that meet the needs of differing age groups. The design concept was studied at three different scales including a base classroom



**Figure 3.3.1.1** single classroom exploded axonometric

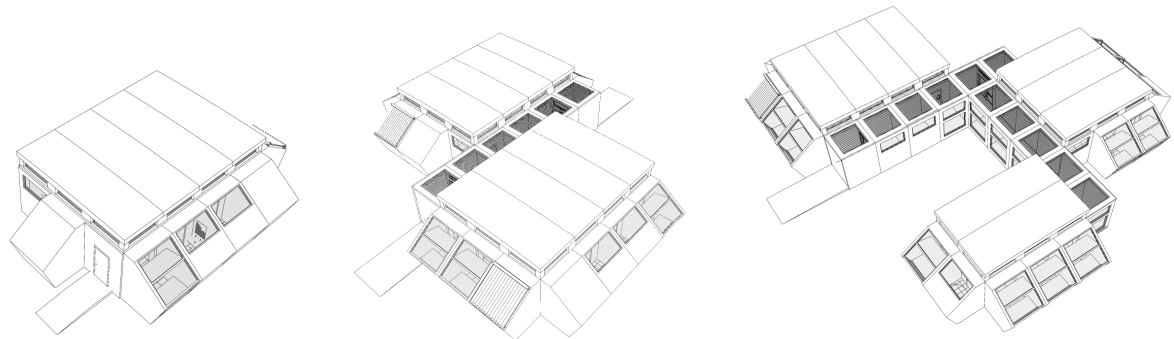
accommodating 25 students, 3 connected classrooms, and 20 connected classrooms with support functions (ie: teachers offices, janitor closets, etc.) included. The designs all abide by ADA and International Building Code regulations. The concept for a relocatable building structure was primarily explored, emphasizing both component demountability (temporary foundation, simplification of joint details and detachment from local resources), and durability (use of re-usable building materials and components).

### 3.3.2 Building Systems

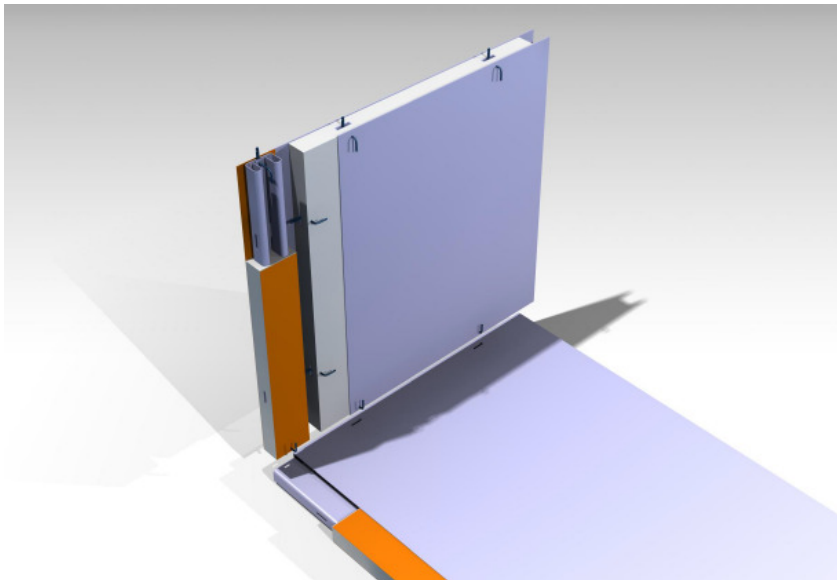
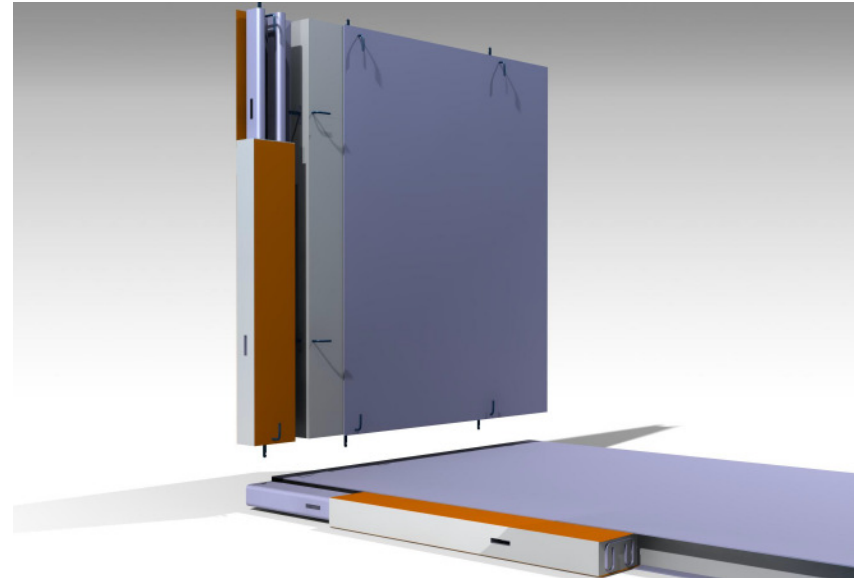
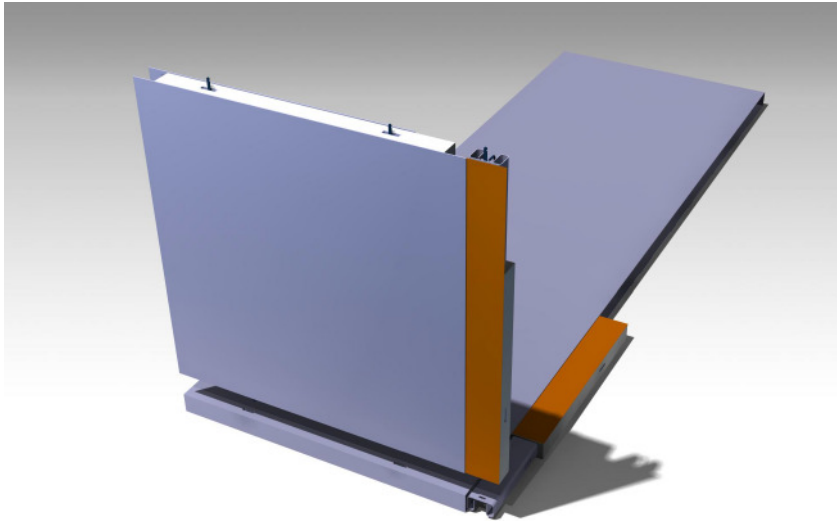
Educational facilities require flexibility in their distribution of both space and resources. Constraints on classroom floor area, ceiling height, access to daylight, and views to the outside vary depending on the application. Similarly, building orientation and the surrounding environment cannot be predicted. A basic structural system, using highway transportation size limits for the controlling dimensions, act as the canvas for offsite components to be plugged in wherever they are deemed necessary. The prefabricated components include both modular structures (pods) that can be handled with a forklift, and panelized structures that can be handled by a manned crew. Ultimately, the overall flexibility of the system is dependent on the library of components available, which over time can be substantial. Envisioned auxiliary teaching functions for the pods include locker and storage units, light shelves or greenhouse space, teacher storage, media and audio/visual equipment outlets, laboratory spaces,



*Figure 3.3.1.2 duplex option exterior photomontage*



*Figure 3.3.1.3 one, two, and three classroom options*



**Figures 3.3.2.1, 3.3.2.2, and 3.3.2.3** SIP assembly: Birds eye view of wall panel and floor panel SIP's with embedded cam lock mechanism and foamed-in-place column and beam spline elements (drawings by Brendan Johnston).

demonstration and study areas, and display space. Functions that are considered necessary for a sustainable external classroom include pods dedicated to air-to-air heat exchange (including an enthalpy wheel) and a 13 amp air conditioning unit, electricity generation (including a photovoltaic array, a battery bank, and a 50 amp generator), a solar water heater (including a solar thermal panel array, and a water tank), a grey water recycling system, and an accessible restroom facility (including a low pressure sink, and a low flush incinerating toilet). Locating utilities on the perimeter subtracts access to views and daylight, but this way pods can be shared between classrooms and solar collection pods can be oriented at the optimal angle for solar gains.

The assembly process is simplified by the integration of a cam lock system (tightened by hand with a hex wrench) into the structurally insulated panels (SIP's). It was determined that SIP's manufacturers could produce six inch panels that could span 24 feet while maintaining an R-value of R-24 by itself. In addition, a 3 inch external camber could be applied to roof panels for water shedding. A light steel frame structure is exposed on the interior. Structural redundancies at the seams of the SIP components maximize flexibility in the configuration of spaces, and though a 12 foot floor-to-ceiling height is targeted, flexibility in ceiling height can also be achieved with varying column sizes. Component mate lines remain unfinished with access to the cam locks uncovered for easy demountability.

The 6 inch soy based foam insulation used for the panels proves to be a safe material with some structural integrity. The 1/16 inch phenolic resin sandwich layers are adequate for weather proofing, smoke proofing and finish customization (by color). And 1/8 inch magnesium boards can further be applied as a non-combustible interior finish alternative to gypsum wallboard. With window assemblies having up to an R-10 value, and appropriate design strategies maximizing their thermal performance, the spaces can be filled with natural light minimizing the necessity for electrical lighting during school days. A floating cork floor (with interlocking panels) is used as a soft surface for improved acoustical performance, while helical piles (providing that the appropriate soil composition is available) makes the construction completely demountable, creating only temporary site disturbance.

### 3.3.3 Initial Cost Review

The primary known barrier to the construction of the case study project has been proven thus far to be cost – with the initial construction cost data established by the Office of Public Education and Maintenance (OPEFM) (\$125 per square foot or \$90,000 per classroom), a 10% tolerance level was established for the

upper limit. The current cost of the SIP's was priced at \$45 per square foot of surface area (though slightly lower for wall panels). Similarly, the initial cost of solar power is substantial, and the rate of return on the investment is typically 20 years. Even with solar power installed, a back-up power system is still required; therefore a connection to the local grid will have to be installed. Similarly, grey water cannot be used in sinks, so the building must also be connected to the local water system. In an internally load dominated building like a school, where the cooling load is substantial, cross ventilation and a thin plan should be considered in the design. Finally, helical piles require a stable soil composition, and the ability of the building to be sited to take advantage of solar power or a solar water heating system are unknown variables in "siteless" building design.

When presented to a client, the design was well received; but the cost was estimated over the established budget. Design merit alone cannot justify an investment, therefore a cost effective prototype must be established. It is not the purpose of this research, however, to come up with solutions to the construction cost criteria; but to investigate the feasibility of a flexible building design intended for mass fabrication through offsite construction.

### 3.4 Description of Participants

All participants were chosen because they were considered industry leaders in modular construction. The decision to visit the plants of Company A and Company B was made because they contrasting manufacturing processes as evident by their plant layouts. Companies C, D, and E were selected because they are currently using BIM and some level of automation in their manufacturing processes. *Figure 3.4.1* provides a comparison of the size of the five companies and the experience of the individual stakeholders who participated in the interviews.

#### 3.4.1 Company A

Company A is a wholesale manufacturer that markets relocatable buildings through local and regional dealers. Building applications include construction site offices, business offices, mobile testing and learning centers, mobile laboratories, workshops, restroom and shower facilities, clean and decontamination rooms, event ticketing concession booths, and utility storage units. The manufacturer also produces permanent modular buildings and various prefabricated structural components. With more than 40 years of experience in the modular construction industry, the manufacturer has three factories and over 225 employees combined (including production and office management). The factories produce a total of 1,150 modules per year on average, and are currently equipped for wood, steel, and concrete construction. The manufacturer runs a manually operated assembly line process capable of custom building component

fabrications.

Overview of the assembly line process:

- Detachable hitch, axels, and wheels are purchased from a third party and installed in-house on a factory produced steel chassis.
- The floor pan for concrete slab construction, steel joists, or wood joists are attached to the steel chassis.
- Wall assembly: Surface of the interior finish is laid face down with studwork and insulation layers all applied until the full panel is ready to be lifted and set in place with ceiling mounted jigs (openings are fitted with wood studs so that window and doors can be screwed in place easily).
- Roof assembly: Roof construction built with a pulley system integrated into the structure so that the unit can be lifted into place by the ceiling mounted jig system.
- Plumbing installation is handled by specialized labor.
- Electrical installation is handled by specialized labor.
- Mechanical systems, interior trim work, and door and window assemblies are all installed before exterior finishes are applied – finish work at the seams is set back so that full-sized panels can be fitted onsite, with the required materials laid loosely on the module's floor.

*Figures 3.4.1.1, 3.4.1.2, and 3.4.1.3* pictures taken at Company A's factory



*Figure 3.4.1.1:* Steel frame wall panels are fitted with 2x4 wood construction for easy window/door installation.



*Figure 3.4.1.2:* Overhead pulleys/jigs installed throughout the factory for the handling of floor panels, wall segments, and roof components.



*Figure 3.4.1.3:* Completed modules are wrapped to protect them from the elements until it is delivered to its final site.

### 3.4.2 Company B

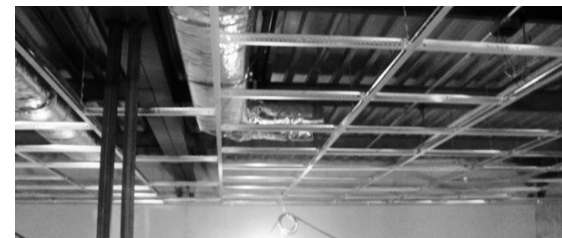
Company B is a custom building manufacturer that specializes in permanent modular construction for various industrial, commercial, institutional, and retail building applications. From their offices abroad, the manufacturer also markets relocatable buildings including mobile classrooms, medical clinics, banks and offices needed for disaster relief efforts, and temporary space for short-term business programs. The manufacturer has one US factory with 8 years of experience invested in the permanent modular building market, and over 35 years of experience in the modular construction industry overall. The US location has a workforce of 30 employees consisting of construction managers, project managers, and a core of certified welders responsible for the construction of the structural steel. There they have completed 47 buildings to date, broken into any number of modules after full offsite preassembly. The manufacturer features an offsite preassembly process (referred to as the 'Build-Together Process') executed by hired subcontractors on a temporary foundation at the factory in a comparable fashion to onsite construction.

Overview of the offsite preassembly process:

- Starts with fabricating a base steel structure in house.
- Steel structure is taken outside and attached to a temporary pier foundation.
- Concrete is poured as a monolithic slab.
- Exterior sheathing, roofing, and mechanical systems are applied.

- Exterior stud framing is done and the building skin is weatherproofed for continued construction in the inside of the building.
- Interior partitioning and wiring is installed.
- HVAC, piping, electrical, and sprinkler systems are all installed and tested.
- Interior finishes are installed.
- Building is deconstructed (concrete slab is cut), packaged, and shipped to the site.
- Building is reassembled onsite and finished at the seams.

*Figures 3.4.2.1 to 3.4.2.4 pictures taken at Company B's factory*



*Figure 3.4.2.1 (top):* Steel structure is fabricated in-house by company employees before being moved outside and installed on a temporary foundation.



*Figure 3.4.2.2 (second from top):* Structure is duplicated at mate lines, including beams and temporary steel columns which are installed for the structural integrity of the modules, but can be removed after onsite assembly is completed.



*Figure 3.4.2.3 (third from top):* A monolithic concrete slab is poured as soon as the steel structure is complete, but it is cut near completion offsite so that modules can be separated

*Figure 3.4.2.4 (bottom):* Finishes (wall, floor, and ceiling) and building systems are separated at mate lines after being tested, requiring pipes to be reconnected by the onsite general contractor.

### 3.4.3 Company C

Company C is a custom building manufacturer that produces both relocatable buildings and permanent modular buildings. Building applications include housing, dormitories, prisons, schools, banks, and equipment buildings for cellular communications towers. The manufacturer also markets restroom modules for multi-story buildings constructed onsite. With over 70 years of experience in the modular construction industry, the manufacturer has one plant employing approximately 200 people between office and production staff. They produce around 1,000 large modules (4 per day) and 300 bathroom pods (for 1 or 2 big projects per year) annually. The manufacturer and the architect work on a design-build contract with close coordination beginning at the start of design through the shipment of components. Architects involved in projects typically have experience with the modular manufacturer's process from previous collaborations. The manufacturer uses automated machining operations for custom steel formations integrated into an otherwise manually run assembly line.

### 3.4.4 Company D

Company D is a wholesale building manufacturer that produces both relocatable buildings and permanent modular buildings that are marketed through local and regional dealers. Building applications include schools, classrooms, bank buildings, dialysis clinics, club houses, office buildings, and dormitories. Historically, the manufacturer has also developed projects for several different military

contracts ranging from the development of affordable housing alternatives to providing communication equipment buildings for shipment all over the world. The manufacturer currently has three factories located throughout the country (Midwest and West Coast), and over 40 years of experience in the modular construction industry. The manufacturer has between 200 and 250 employees. As a custom builder, their production rate per year varies considerably based on the size of projects. For example, one of their three factories is currently in the process of completing a project comprised of over 500 modules.

### 3.4.5 Company E

Company E is a residential building manufacturer that takes responsibility for the design, engineering, manufacturing, shipment, onsite assembly and finish, and management of foundation work. Over the past 5 years, the manufacturer has developed a series of kit-homes in which modular assembly variations can be composed online with accurate cost estimation and a virtual tour. The manufacturer has one plant providing services throughout the country focused on LEED certified construction. They employ between 130 and 150 workers, and produce approximately 300 large modules annually on a manually operated assembly line process. Automated machining operations are also currently used for custom steel forms.

*Table 3.4.1 (next page):* comparative table summarizing the size and experience of Companies A, B, C, D, and E, and the experience of the stateholders

	Company A	Company B	Company C	Company D	Company E
<b>Company Size</b>					
No. of employees	225	30	Between 100 and 250	Between 200 and 250	Between 130 and 150
No. of factories	3	1	1	3	1
Years of experience in the industry	40	8	70	40	5
<b>Production</b>					
No. of modules produced annually (estimation)	1,150	N/A	1,000	>500	300
<b>Specialization</b>					
Type of projects (not exclusively)	Relocatable buildings for comercial construction	Permanent modular buildings for commercial construction	Permanent modular buildings for commercial construction	Relocatable buildings for comercial construction	Permanent modular buildings for single family home construction
<b>Process</b>					
Production process	Assembly line	Offsite preassembly	Assembly line	Assembly line	Assembly line
Current use for BIM/3D-CAD	After-the-fact models produced for contractual requirements	None, but installed and taught to workers in-house	Used to produce shop drawings, assist production on the factory floor, and for in-house inspections	Used to produce shop drawings and to assist the inspections process	Used to produce shop drawings and to assist the inspections process
Automated machines used	None	None	Some use in steel fabrications shop	Plasma cutter, CNC press, and robotic welding	CNC roll form, 3-axis CNC router, and waterjet cutter
<b>Stakeholders</b>					
No. of participants	3	1	1	1	1
Job titles	Principle, Sales Manager, and General Manager	General Manager	Director of Architecture and Engineering	Director of Marketing and Business Development	Vice President of Product Development
Years of experience in the industry	32, 32, and 28 respectively	39	1.5	13	4



## CHAPTER 4: DATA COLLECTION

Data collected for this study were obtained through five interviews. Companies A and B were interviewed face-to-face, and Companies C, D, and E were interviewed over the phone. Questions asked encompass the feasibility of the case study project as it relates to each manufacturer's current process and factory arrangement, and concerns faced by the industry in general where design and production innovation are concerned. The interviews have been summarized in the following chapter and full transcripts can be found in *Appendix B*. Clear themes in both the lines of questioning and in the responses can be identified for direct comparisons. Data presented by theme in bullet-point form are appended to the end of each summary.

### 4.1 Company A Interview Summary

**Q:** *What is the driving force for interest in modular construction – either interest coming from architects or clients?*

**A:** Although the market perception is better than

it was 20 years ago and the products coming from the factory are gaining recognition, **clients primarily come to manufacturers expecting lower construction costs and a faster built product.** While speed is typically easy to achieve – as foundation work is being done onsite, manufacturers are building modules at the same time, saving nearly 30-50% of the time for construction – **cost savings in construction duration are typically offset by module transport costs.**

The industry is becoming better known for quality and as an inherently greener building process, but it is still likely that less than 5% of architects design modular buildings. As LEED certification systems are gaining recognition, **more architects will try modular construction as an alternative to site-built construction because there is presumably less waste** (materials are bought specifically sized for the project), **and because there is less site disturbance during construction.** Manufacturing techniques are getting more

sophisticated, and building codes more stringent, so the end built product produced in the factory is comparable to a site built equivalent. **Permanent modular buildings are expected to be indistinguishable from onsite built buildings.**

**Q:** *What types of projects require an architect's involvement?*

**A:** **Schools tend to go to architects for help.** While low end \$45 per square foot trailers are still being produced in the industry, the industry has grown in the public's eye as an alternative way to build because there are built precedents featuring high-end materials and durable construction.

**Q:** *Can component re-use, building portability, and the life cycle value of materials be used as a strategy to compensate for higher initial construction costs?*

**A:** A big percentage of the industry's business is in educational use buildings. School districts already understand that portable classrooms can both be moved as enrollment or demographics change, and leased out for different functions. Therefore, **there is potentially a market for a \$120 per square foot classroom that will last 25 years versus a \$45 per square foot classroom that will last 5 to 10 years.**

The price of SIP's construction, however, is estimated to be 28% more expensive than standard stud frame details, though the

creative use of the material as an interior and exterior finish surface makes it a more viable option because of the elimination of labor costs for finish work. A \$4 or \$5 per square foot tile finish (for the floating floor) is also not typical in the modular building industry.

So, while the materials being specified by architects right now are taking into account the life cycle value of materials (durable) and components (re-usable). But from a marketing perspective, **the strategy is to focus on the financial benefits of construction speed in comparison to a fully onsite constructed building: either by reducing the costs of displacing workers, or through the opportunity to turn profits sooner.**

**Q:** *When or how often are advantageous changes to the manufacturing process pursued?*

**A:** **As a custom builder, the factory is built to be able to switch from one process to another.** Yet there is a start up cost associated with changes to the fabrication process – the assembly line has to be geared up to handle new materials, and there will be a dip in labor productivity initially. So, **if only a small number of components are being fabricated at a time, it is hard to recover from the start up costs involved.** The plants will evolve over time incorporating additional processes and materials, but it is market driven – **a large volume of demand will initiate change, or a large-revenue project.**

**Q:** *Is the level of precision required for component fitting a major obstacle in the fabrication process, and does volume factor in the feasibility of the design from either an economic or a production standpoint?*

**A:** Efficiency and quality increase with repetition because workers can become familiar with the process.

**The SIP's in the case study project would be purchased by a specialized manufacturer and assembled and packaged at the factory.** The demand for a high volume of components would be required to make a factory within the company solely dedicated to SIP's manufacturing.

**Q:** *Is it advantageous to do finish work offsite, or do components run a risk of damage being accumulated during transport?*

**A:** **Architects are not typically familiar with the different transportation codes** that building manufacturers have to follow. Height, width, length, and weight of modules are all restricted by the physical limitations of the truck and the road. Modules shipped on a flat-bed, for example, are restricted to a 12'x56' footprint, while modules with a built-in axle and wheels can have a footprint of 16'x80'. Similarly, concrete modules have to be built smaller than wood assemblies because of the difference in the weight of materials.

So, **the major challenge is in planning a module's travel path and building it**

according to the code restrictions of each different state it will pass through – schools can obtain a permit from the Department of Transportation for exceptions.

**Problems in component transport can be attributed to driver error, or to damage by tree limbs.** Company A uses a spray foam sealer for stud construction as an alternative to nails in an attempt to make frames more rigid for transport.

Though it varies for temporary and permanent facilities, **the only finish work not done offsite is at the module lines** (though projects that require more onsite work will typically not have a completed ceiling or floor finish either).

**Q:** *What is the role of an outside general contractor?*

**A:** **There would be an outside general contractor in charge of onsite pre-work** (soil testing, utility connections, excavation and foundation construction) **and component assembly**, which can be a coordination challenge because the selection of the contractor is usually price driven. Therefore, **the larger and more complete** (with finishes and simple utility connections) **the components can be built in the factory, the more control the manufacturer has over quality and construction speed.**

**Q:** *Is labor within the factory specialized?*

**A:** **The more specialized the work (plumbing,**

**electrical, heating and air conditioning), the less new workers can be introduced into the process.** But for most work in the plant, cross training is possible (moving workers around to get experience in different areas) and it is important for competitive labor costs and construction speed.

**Q:** *To what extent is BIM (3D-CAD) being used in the manufacturing process today?*

**A:** **BIM is used as a supplement** (to keep on file) to the work already done in the plant (**done after-the-fact**). The engineers on staff do the design work and the drawings, and in a time sensitive building process, familiarity with the computer software is necessary.

**Q:** *Is there a difference in the type and the quality of drawings required for offsite fabrication in contrast to the construction documents needed for a comparable stick-built operation?*

**A:** **Shop drawings are always going to be produced;** not only for buildings designed in-house, but also for those designed by an architect. Each plant works differently, and their engineers will develop a customer approval package that goes to a third party for code review, and then to the architect and the owner for design review.

**Q:** *What in-house quality control measures are taken to ensure the precision of component fabrication?*

**A:** **Tolerance levels can be met easier in the**

**factory.**

Plumbing systems are important to be tested with air pressure offsite, so **it is necessary to test systems wherever they cross module lines.** The easier the systems are to install (quick-connects), the more quality in the final installation can be assured.

**Q:** *If the onsite foundation is constructed by an outside general contractor, are there additional challenges at the interface in terms of a technology gap, the equipment or tools used, the construction experience of workers, or in scheduling and phasing of construction?*

**A:** The scope of the work will be clearly defined in the shop drawings, so **the general contractor is expected to work from the drawings created by the manufacturer, not the set made by the architects.**

Pre-planning with contractors doesn't happen very often because of time restrictions, but it is beneficial because roles are clearly established. The contractor leaves **knowing what to expect from the work being shipped from the factory in terms of the amount of finish work done, systems installed** (eg: whether or not sprinklers are installed with the ceiling), **and the break-down of the plan into pre-assembled modules** (in which the roof is sometimes separated from the rest of the building for taller ceiling heights).

**Q:** *How would it benefit the manufacturer to be included in the design development of a*

project?

**A:** In the rare situations where design charrettes have been used that involve the architects, engineers, fire and safety specialists, and building manufacturers, **the additional communication upfront between all parties makes the transition between trades easier because the responsibilities are understood before work is passed along.** The problem, however, is that **most companies don't build that time into the project;** manufacturers are asked to bid on projects that require an accelerated construction schedule.

Because the **experience of manufacturers can be used to aid the design process** – module division, coordination of what will be done offsite versus onsite, and the understanding of travel limitations and the most economic shipping methods – it is beneficial to get them involved as early as possible in design development.

**4.2 Company B Interview Summary**

**Q:** *What strategies are taken among manufacturers to either improve the public perception of modular construction or to promote its advantages to architects and potential clients?*

**A.** Often **customers automatically expect modular buildings to be less expensive and have a faster construction speed** when compared to site built buildings. There can be a negative stigma associated with the term “modular” because of examples in history that

Topic	Response
Market Perception	Schools tend to go to architects for help, as well as permanent modular construction  Time savings, not building cost savings can be expected
Fabrication Process	The more work that can be done in the factory (with larger modular structures), the greater the opportunity for the manufacturer to take control of quality and speed
Design Considerations	Transportation limitations: primarily width and length based on state regulations, while conditional limitations on height and weight are dependent on the module's path of travel and type of system used (hitch and axle, flat back, container, etc.)

*Table 4.1.1 themes and pertinent information identified from the interview with Company A*

are built cheap and with low quality. To distance themselves from this perception, Company B uses different terminology (**the process is called “offsite construction” instead of “modular”**), they **make sustainable features inherent in the process prominent** (less site disturbance, less security risk from both theft and from hazardous conditions, better safety at the jobsite, and less material waste and a better chance to recycle materials), and focus on permanent modular projects (**featuring durability**). The purpose is to ultimately establish precedents that feature design drive and high quality modular buildings. For example, having one school district in a major metropolitan area utilizing non-combustible, mold resistant, and re-usable classrooms instead of their low cost equivalent will help advertise the benefits to surrounding school districts.

Because most buildings constructed are permanent modular buildings, **there is also a deliberate effort in the design and execution to make sure that no mate lines are visible** along the floor, walls, or ceiling, making them aesthetically comparable to site-built buildings.

**Q:** *What is the driving force for interest in modular construction – either interest coming from architects or clients?*

**A:** **Both site restrictions and time limitations are where the majority of the workload is generated for the industry.** All marketing dollars spent are used to educate architects on

the “build together” process (their reluctance is a challenge).

**Q:** *Can component re-use, building portability, and the life cycle value of materials be used as a strategy to compensate for higher initial construction costs?*

**A:** **The ability for components to be interchangeable, replaced, and re-used is not a barrier from a production standpoint, but from a marketing standpoint.** Company B has tried to sell higher quality portable classrooms for years in the US (though successfully in Canada), but school districts tend to be more interested in quick-fix, temporary classrooms instead of long term re-usable solutions (which will yield future cost savings).

**LEED awarding systems will help bring the industry to the forefront**, but it will take time to educate the public on how the industry has changed, and how the benefits can be used (portability and re-use of components).

**Q:** *Is the level of precision required for component fitting a major obstacle in the fabrication process, and does volume factor in the feasibility of the design from either an economic or a production standpoint?*

**A:** With the “build together” process, **construction offsite is handled by sub-contractors instead of factory workers** in an attempt to improve productivity and craftsmanship. **Tolerance levels between**

**1/4 inch and 3/8 inch can be easily met** and should be built into the architectural details. By making the process as similar to site-built construction as possible, **it is possible for the company to use an architect’s drawings for construction, to inspect progress and accuracy, and to fully test utilities.** Full preassembly offsite, separation of modules, and re-assembly onsite is however necessary for sub-contractors who are used to site built construction, not prefabrication on an assembly line.

**SIP construction for the case study project would likely be done at a lower cost and a faster speed by a specialized SIP manufacturer.** Any aggressive manufacturer that intends to maintain control over the production of the SIP’s could gear up their production facilities, but one with an established assembly line would be more adept in adjusting the process to accommodate foamed-in-place panels because they already have the jigs in place.

Volume building makes the establishment of a new process economic, and the scale of the project provides manufacturers with purchasing power (suppliers discount bulk purchases).

**Q:** *Is it advantageous to do finish work offsite, or do components run a risk of damage being accumulated during transport?*

**A:** Transportation limitations are more critical in an assembly line process that builds modules with an integral hitch and axle because the

module becomes in essence a vehicle and falls under motor vehicle laws. **Components shipped on a flatbed trailer qualify as “freight” and can be shipped at larger sizes at a higher price and listed as a “super load.”**

The potential for damage during transport is always present, but they are rarity. Tree-lined streets are the biggest problems, and **roads can be inspected ahead of time** (and branches cut). Narrow streets must be accounted for in the design of modules.

Floor finishes are typically not completed offsite because of the amount of traffic onsite builders will put on the floor surfaces, but **some clients will require a specific completion percentage in the building contract** (limiting the amount of onsite construction expected).

**Q:** *Considering all components are pre-fabricated offsite, what is the role of an outside general contractor?*

The purpose of the general contractor is to do all of the site prep-work, running of the utilities, foundation construction, and installation of the final assembly; **ultimately the general contractor will bear the responsibility for the end result.** It is important to get the general contractor involved as soon as possible so that they understand the manufacturer’s building process and know exactly what will be delivered onsite. **While contractors are invited to the plant, a project manager in-house is assigned to a project for its**

**duration** (both offsite and onsite).

There is often a disconnect between the manufacturer and the general contractor. Some manufacturers, however, will handle all of the work. **Company B is licensed to do onsite work only in-state.**

**Q:** *To what extent is BIM (3D-CAD) being used in the manufacturing process today?*

**A:** **BIM has been installed and taught to the workers at Company B. However, no project has required its use from start to finish (initial requirements have been lifted in each instance).** The integration of BIM requires clients to invest time and money into its upkeep (understanding that it provides immediate access to the location of utilities and their specification), and architects must be willing to share the drawing files for information to be added. **Architects, however, are not willing to share their drawings because of liability issues** – they are afraid that if changes are made to the drawings that create onsite problems and added costs, then they would be suspect to legal action from the client.

Factory workers and engineers build a structural steel frame in-house, and it is moved outside and set on a temporary foundation for the work of sub-contractors to be done. **In-house engineers would provide shop drawings (production drawings) for the steel only,** unless the architect cannot bring the drawings to a construction drawing level of detail.

**Q:** *Is there a difference in the type and the quality of drawings required for offsite fabrication in contrast to the construction documents needed for a comparable stick-built operation?*

**A:** With the “build together” process, modules are built from an architect’s drawings, with steel shop drawings created only as a supplement. **The architect therefore maintains ownership of the drawings and that commission.** In a process where shop drawings replace the architectural documents, the value of the architect’s drawings is reduced as well as their overall contribution to the process.

**Q:** *When are automation and the integration of a machined process feasible in the fabrication of components?*

**A:** **Automation requires volume,** particularly at start up because of upfront costs, and although it is important to maintain that volume, if the manufacturer has enough diversity in their work, the CAM tools can be set aside and easily reinstalled for later work.

**Q:** *What in-house quality control measures are taken to ensure the precision of component fabrication?*

**A:** **Full preassembly is done offsite so architects and clients have the opportunity to inspect the building’s progress and quality, and so the utilities can be tested.** Finishes at the module lines, and utilities crossing module lines are removed so that modules can be separated for shipment.

**Q:** *If the onsite foundation is constructed by an outside general contractor, are there additional challenges at the interface in terms of a technology gap, the equipment or tools used, the construction experience of workers, or in scheduling and phasing of construction?*

**A:** **A project manager is sent to the site to oversee onsite foundation work and assembly to make sure that everything aligns with the modules being built offsite.** The project manager is intimately knowledgeable about the entire manufacturing process. Though it takes extra time and money, it makes the transition between trades easier.

**Q:** *What are the primary challenges in the transition from offsite component integration to onsite pre-work?*

**A:** The more work that can get done in the factory, the more the manufacturer can control quality. While flexibility built into the design of the case study project requires smaller components that are all interchangeable, the breakdown doesn't have to translate literally into the division of members shipped (it would be beneficial to preassemble larger modules offsite to reduce onsite labor).

**Q:** *How would it benefit the manufacturer to be included in the design development of a project?*

**A:** **If the manufacturer is able to sit down with the architect once a preliminary design has been established with the client – to**

Topic	Response
Market Perception	<p>LEED awarding systems will bring the modular industry to the forefront</p> <p>Modular construction provides an alternative service to site-built construction enabling multi-uses of a product at different locations throughout its life cycle (adaptable to the needs of the user over time)</p> <p>Modular construction is most applicable to building programs with a restrictive timeline and unusual site conditions</p> <p>Advertise the benefits which contrast directly to onsite construction</p>
Fabrication Process	<p>A general contractor will be hired to install components onsite unless the project is regional</p> <p>It is costly to change the factory around, so unless you have the appropriate volume, specialized fabrications will be handled by an outside consultant</p>
Design Considerations	<p>Understand and plan what will be done onsite versus offsite, based on cost effectiveness and where the benefits of modular construction can be utilized</p>

*Table 4.2.1 themes and pertinent information identified from the interview with Company B*

make sure that where the mate lines are laid out from module to module is accurate, and to define where the structural steel needs to be located – **the better the chances are that the blend between the architectural intent and the production process fits together.**

#### 4.3 Company C Interview Summary

**Q:** *At what stage of the design process should the manufacturer meet with the architect?*

**A:** **The manufacturer needs to be on board from day one**, not even giving the architect a head start. **The design-build process** used by Company C **involves a packaged bid set in which the construction manager, manufacturer, and architect are chosen together as a team.**

**Q:** *After that initial coordination meeting, how intense is the coordination between the architect and the manufacturer throughout the rest of the design process?*

**A:** The level of coordination is intense because **the pace is consistent and the deliverables are evenly spread out.** Beyond deliverables, however, ongoing communication is necessary because of the accelerated schedule. **This requires weekly meetings between the architect and the manufacturer,** or sometimes a dedicated staff working full-time in the architect's office.

**Q:** *What influence does the manufacturing process have on the design of a modular building?*

**A:** Each modular manufacturer has a unique system, and the system has a critical influence on the design of the project. The plant floor isn't going to be rearranged for any new project, and the equipment available in the factory affects the materials that are used.

**Q:** *Where can the education of the architect improve in regards to modular construction?*

**A:** The education of the architect is centered around what is and isn't possible in the particular factory, and ultimately **that discussion is part of the sales courtship and outreach program of the modular manufacturer** as they present precedents and their research into systems and details.

What is largely unique to each manufacturer is the design of the structural system used for modules. **So it is important for the manufacturer to define the variables and the absolutes of the system to the architect.**

**Q:** *Can you identify some general design considerations that are unique to modular construction?*

**A:** **Fire ratings are difficult to understand in the modular world.** It requires intensive detailing – typical details involve wrapping the steel in layers of drywall or using intumescent paint – and it requires inspections during design and production that will impact the project schedule.

**Building tolerances into the drawings is**

**also not something architects typically have to deal with.** Instead of absolute dimensions, spaces need to have “give” in them, because there are material thicknesses and elements that are not given consideration – glue thicknesses, grout thicknesses, screw heads, etc. For this reason, it is important to add a higher level of detail and increased coordination into the design process, requiring more design costs upfront.

**Q:** *Are you always required to produce a set of shop drawings as a supplement to the architectural drawings for projects built in the factory?*

**A:** In terms of AIA procedure, construction documents are the product of the architect. Verbally and legalistically, they are the coordinated set of all the trades coming together. **Shop drawings** act as the set of commands handed to the builders, and therefore **act as the architect's check of the work that is expected to be done, and as a financial check** because material orders are based off of the quantities indicated in the drawings.

**The way around the need for shop drawings requires constant dialogue** between the manufacturer, the architect, and the engineers (structural and MEP) early on. **For that reason Company C would usually work on a design-build contract,** and exclusively would **draw from a preferred vendor pool** (primarily working with architects that they have worked with in the past) who understand their manufacturing process and **who don't**



**need educating on modular manufacturing processes.**

The main challenge to working in a design build contract is the fact that **it reduces the competitive bidding** process that clients try to take advantage of, and architects also fear that it takes away some of the control they have over the design.

**Construction documents are inadequate for making a modular building** because a manufacturing process crosses into the realm of industrial production, requiring details and a level of organization specific to the process unique to each different manufacturer. For example, the drawings set is organized to be one sheet per station on the assembly line because the modules being developed are isolated from the rest of the building.

**Q:** *Can you explain the third-party approval system that you have to go through for modular buildings?*

**A:** **A state certified third-party agency is hired to inspect and license modular buildings.** They travel to the factory whenever trade work has been completed, and progress and payment are halted until that work can pass. Periodic or continuous inspections can be offered, though continuous inspections are generally undesirable. For simple buildings/structures, the same inspection agency stamps the shop drawings as well.

**When the module leaves the factory, the**

**manufacturer is done with the job.** Therefore, it is not the responsibility of the manufacturer to make changes after that point at all, as it is the ownership of the client once it has been delivered onsite.

**Q:** *How are precision and quality ensured without full preassembly being done offsite to check fitting and tolerances?*

**A:** BIM is placing the responsibility on the architect to be the master builder, much more so than what we've seen in CAD. **The BIM model brings the problems of construction forward, making it possible to catch conflicts** before the drawings are sent to the factory floor. With a detailed BIM model assisting the construction process, Company C could eliminate preassembly in order to coordinate where pipes and mechanical ducts end at module lines.

**Q:** *What led to the integration of BIM in the manufacturing process?*

**A:** Company C abandoned 2-D CAD-based working back in 2004 or 2005, and they were able to transition easily because they already have to work at a high level of digital preparation because they use automation in their fabrication process.

**Q:** *To what extent is BIM being used in the manufacturing process today?*

**A:** If the **BIM** model is prepared before fabrication, it can be **used as a supplement**

**to the drawings**, allowing the shop drawings to be minimal and easier to handle (making it easier to find information) on the factory floor.

The centralized database of building information in a 3-D model is typically primary benefit for the use of BIM. Revit modelers are encouraged not to "over-model," however, Company C **the models were highly detailed and separated into a series of files** organized by a workflow diagram.

The level of detail and effort put into the model early, though costly, ultimately reduced the number of RFI's requested from the department and saved money in the long run.

The challenge of having so much detail in the BIM model is that it makes files difficult to work with (virtual memory), and while Revit "groups" are a recommended solution, they are not very polished and are difficult to work with.

**Q:** *Who ultimately is responsible for the quality of the model?*

**A:** Using a live BIM model in which each company makes their own additions where necessary is only possible in a large design-build outfit where everything is in-house. Otherwise, **the model is property of the architect and the engineers**; so because the manufacturer cannot be the ones literally making changes, **they can still do a lot of direct commanding as to what needs to be worked on.**

**The AIA E202-2008 BIM Protocol Exhibit**

**document has taken the initiative to define the Level of Development (LOD) and the Model Element Author (MEA).** The LOD defines the level of detail a contractor (or contributor), would need to provide contractually. The MEA's are the parties responsible for developing specific model content. It is not a formal addendum required in project contracts, but it is a step for the development of BIM Management Plans.

**Q:** *What has in the past made it possible for you to experiment with the concept of a paperless production process – using the BIM model for construction instead of shop drawings?*

**A:** The opportunity to engage in a paperless production process using the 3-D BIM model as the tool for communicating not only the design intent but the instructions for the builders, is possible primarily in design-build outfits where constant coordination between the designers (engineers) and the builders is aided by the fact that the two disciplines are in the same building.

**The challenge is that it requires more time at the front of the project to develop a detailed 3-D model** as opposed to the requirements for an accurate 2-D set.

**Q:** *What are the barriers to making this possible and altogether eliminating the need for shop drawings?*

**The legal approval process** (including both the approval of drawings by the third-party

code reviewer, architect, and client, as well as the periodic or continuous inspections of trade work by a third-party reviewer) **can be a challenge** because currently the shop drawings are the only documents that will stand up in court.

The dimensions on the shop drawings are historically considered the demands for the construction; **there is no precedent for the BIM model being a legally accountable entity.** Many firms currently do not have a working BIM contract, meaning that they are not building in the appropriate amount of time to create an accurate 3-D model with all building elements (mechanical, electrical, plumbing, etc.).

**Q:** *What level of automation is being used in the manufacturing process today?*

**A: The CNC press was used for metal panel fabrication** for bathroom pods, communication buildings, and even metal studs (though the challenge with the studs is in getting their UL fire rating). **SolidWorks models were used for the press.**

Similarly, **the Peddinghaus Ring of Fire (plasma cutter) was used for automated steel cutting.** The machine did not interface with Revit. The databases created by the Revit model, however, could be used to transfer information from the model to the machine's software, which was essentially an Excel chart.

**Robots were rarely used in factory, but they drastically reduced weld times** (a 3-day job could be reduced to 45 minutes). They were mainly used for pure manufacturing in highly repetitive jobs because, though the agility of the machines was impressive, **the software was a disappointment** (working like a calculator). So minor changes to the activities conducted required full program re-writes.

Another challenge for the robots was in getting them certified. **The Steel Welding Institute required the robots themselves to be certified (like a person)**, while the operators of the machines did not have to get their own certification.

**Q:** *What is the greatest barrier to mass customization: the complexity of the software associated with the tools, and/or their inability to interface with preferred CAD programs, the need for specialized training for the operation and/or supervision of the hardware; or the limited number of operations and materials that the machines can be used for?*

**A: There is a disconnect between the advanced technology available in robotics and the software used to operate the machines.** Honestly, architects are ahead in the notion of mass customization, where "custom tweaking" can be easily manipulated in programs like Revit and Grasshopper.

The software associated with the machines (which come packaged with the machines) is not nearly advanced. **So really the only**

**use for the machines was for aggressive manufacturing** – completely repetitive processes. This includes minor changes like adjusting cuts by 1/8” (and there are so many factors that will skew the repetition of parts) which could not be done without an intensive rewrite of the program. It is hard to sell completely repetitive work to an architect, and that is its greatest barrier to use in the modular world.

Any changes to the repetition of parts slows down production because of “the human factor.” Beyond the software modifications, the handling of a large number of parts (particularly the more they are differentiated), the slower the workflow goes. Therefore, **until the entire process is fully automated, including assembly and not just the making of the parts, the concept of mass customization will be hard to achieve.**

Without the level of volume available in the automobile industry, it is hard to make full automation cost effective because variation in the modular building world is more significant than that in the automobile industry.

#### 4.4 Company D Interview Summary

**Q:** *What is the driving force for interest in modular construction – either interest coming from architects or clients?*

**A:** **A modular manufacturer will typically be able to get their foot in the door based on necessity:** restrictive site conditions, expensive local labor costs (ie: in urban areas),

Topic	Response
Fabrication Process	The responsibilities of the manufacturer end when modules leave the factory because they are inspected and approved along the way; so changes and the finished quality is at that point the responsibility of the general contractor
Design Considerations	Tolerances must be included in the design and the drawings (1/4 inch and 3/8 inch tolerances can be met easily)  Fire ratings in the modular world require intensive detailing
Design Coordination	The industry is leaning towards a design-build approach, where a team consisting of an A/E firm, a modular manufacturer, and a general contractor are brought on board together, being in constant coordination from design through installation
BIM	Paperless is possible; or at least paperless on the factory floor as the shop drawing prints will be needed for legal documentation  The development of the AIA E202 document will be used in the future to monitor the quality of the model  Revit groups are problematic; so it is not always possible to have one centralized database
Mass Customization	The tools available are highly advanced, the software is not (ie: "custom tweaking" available in design software like Grasshopper makes manipulation easy)  It is hard to get custom fabrications fire rated (steel studs, panels, etc.)  Robots must be certified like people  BIM integration with some CNC operated tools works at the database level, not the visual model level

*Table 4.3.1 themes and pertinent information identified from the interview with Company C*

or because of a reduced timeline (ie: education facilities).

**Q:** *What strategies are taken among manufacturers to either improve the public perception of modular construction or to promote the advantages of modular construction to architects and potential clients?*

**A:** Modular construction in the public's eye is often equated with manufactured HUD code housing – inexpensive, economical, mass produced-type products. In a permanent modular building, the goal is to make the building indistinguishable from a site-built structure. In the education market, when a school is planning to lease a classroom, they usually spend money on the cheapest option because they expect it being a two-year necessity.

Customers typically have an expectation that the budget for a modular building will drop by 15%, so the challenge then for the manufacturer is to sell the fact that a construction timeline reduced by 25% would result in quicker revenue generation.

**Q:** *Can awarding incentives (LEED Certification points), established precedents illustrating long-term financial benefits, or quality certifications be used to increase the integration of prefabricated components into building design and execution?*

**A:** The price of sustainable building materials have been decreasing dramatically over the

past three or four years, and that trend is expected to continue. Studies have shown that the manufacturing process is a much more sustainable process before even getting into specifications, building systems, and material selections.

**Q:** *How does the strategy to keep panelized components compare to modular building assemblies in terms of quality control and the costs associated with packaging and transport?*

**A:** The pros to building 3-D modules offsite versus 2-D panelized components is the fact that the complexity and the extent of onsite construction is reduced with larger 3-D modules built offsite, so the manufacturer can manage the efficiencies and the quality of the process in the factory. Labor rates are also comparatively low in the factory, so it generally is beneficial to get as much work done in the factory as possible.

However, for projects exported long distances overseas (or potentially by train), **the flat-pack shipping method of a panelized 2-D design becomes more economical because no longer are “empty volumes” being shipped, and instead the maximum capacity of a cargo container is being utilized.**

**Q:** *What type of projects are you best geared for, and how difficult is it to modify your fabrication process?*

**A:** **Traditionally, a project done at Company**

**D is at least 40% complete before it leaves the factory.**

**Q:** *How would a business model for the case study project be designed?*

**A:** The business model that would likely be used for the case study project would require the architect to “shop around” for individual manufacturers that can build the many different sub-assemblies and hire a general contractor to put it all together at the site. This would be effective in a leasing situation, where a distributor owns the subassemblies and rents them out to school systems. The SIP's panels, for example, would have to be sourced carefully, working with an existing panel maker that's already tooled up to build them.

Using a leasing business model for a kit-of-parts system with interchangeable components also requires the end product to comply with the regulations of multiple states.

The project ultimately would not require the services of a modular manufacturer because the onsite general contractor would be responsible for the bulk of the work, and the architect could be responsible for sourcing out all of the component work.

**Q:** *At what stage in the design process should the manufacturer meet with the architect?*

**A:** One problem in working with architects on modular projects is that often times a modular manufacturer is brought in after the project has

been designed for conventional construction and requires some level of re-design. **Coordination at the start of a project, however, can prevent overlaps in the scope of work** of the architect/engineers and the modular manufacturer, particularly in terms of shop drawings that duplicate construction documents and permit drawings.

**A modular manufacturer has a knowledge of local products** (eg: steel truss manufacturers) that can aid in making a design cost effective. These **include value engineering and economy of scale**. Similarly, the manufacturer can suggest the use of products that they can obtain at a discounted price and those which they are already volume purchasing **to help drive the cost of the design down**.

**Q:** *Who is responsible for LEED Certification calculations?*

**A:** The calculations for LEED Certification will fall under the architect's scope of work. The modular manufacturer will write the justification for the Innovation Credit (for modular construction), they will provide mill certificates for the materials used (type of steel/wood/aggregate), and they will provide information on the factory's recycling program. Company D does a lot of work for the military, and those projects are currently required to be LEED Gold certified.

**Q:** *Can you identify some general design considerations that are unique to modular construction?*

**A:** It usually helps if the architect comes into the factory and sees the building systems typically built by the manufacturer and gets an understanding of the particular manufacturer's building process.

**An architect should understand the cross section of a modular building.** Particularly prevalent in multi-story modular buildings, the relationship of the roof structure of the lower module to the floor substructure of the top module presents a unique design condition that needs to be accounted for.

**Material redundancies in modular buildings are unavoidable** because the structure of each individual module must be stable, often doubling columns and beams. The design of a modular building must account for that and consider the consequences and possible solutions.

Dimensional restrictions due to transportation laws vary from state to state. Not only does the design of a modular building have to conform to the regulations of its end location, the path of travel must also be planned and considered. Therefore, **it is important for an architect to be aware of the width, height, length, and weight of modules as well as the consequences of working outside of those parameters** (eg: 16' x60' module is possible, but the transportation cost would be higher if installation is intended for New York City).

**The installation procedure after a module arrives onsite is also important to be**

**considered in the early stages of design.** For example, it can be a challenge to order the sequence in which models are placed and how they are secured without either damaging the modules or putting workers in danger.

**Q:** *Are you always required to produce a set of shop drawings as a supplement to the architectural drawings for projects built in the factory?*

**A:** It is both possible to build from (and to get state approval) an architect's and engineers' coordinated construction drawings set. If the architect has a good enough understanding of the process, and if there is enough detail present in the drawings, shop drawings are not actually required. It is not common, though **Company D has built off of construction documents in the past**, and that is a major reason why the coordination between the architect and the manufacturer early is important – to clearly define what drawings are expected of which discipline.

The challenge then is the fact that the workers at the factory are unaccustomed to the drawing format produced by the architect/engineers. This problem is only an issue for one or two weeks depending on how long it takes workers to get acclimated with the set. So that drawings aren't duplicated, the drawings the modular manufacturer has to do for state approval are typically identified at the beginning of the design.

Architects that repeatedly work with a modular

manufacturer are best prepared to produce a construction documents set that can be used in the factory.

**Q:** *Can you explain the third-party approval system that you have to go through for modular buildings?*

**A:** Drawings are submitted for permit to a state defined governing agency. The full set of construction documents/shop drawings do not need to be submitted to get the state building permit. **Conditional approval will generally be granted in some states if the drawings require changes.**

**A third-party inspection agency is used for inspections in-state, but there are not third-party inspectors designated for all states, so approval is requested from a designated state department.** The third-party reviewer is in the factory 4 or 5 days a week inspecting work, so inspections and approvals are rarely problematic for the manufacturer because they are dealt with so frequently.

**Q:** *What in-house quality control measures are taken to ensure the precision of component fabrication?*

**A:** **In-house quality control measures and owner** (or an owner's representative) **inspections are conducted frequently** in addition to third-party reviews. Every step of the assembly line process is studied to ensure the quality of the product before it leaves the factory.

Topic	Response
Design Considerations	<p>Understand installation procedure and sequencing</p> <p>Plan the cross section according to the relation of components to one another, eliminating material redundancies where possible and planning detailing at the seams</p> <p>Consider economies of scale and value engineering, taking the expertise of the modular manufacturer to help make the design cost effective</p>
Design Coordination	<p>BIM has made coordination easier because problem areas can be visualized both by the client and the builders ahead of time</p> <p>Early coordination can eliminate duplicate drawing sets (CD's and shop drawings)</p>
BIM	BIM is required in government jobs, and its widespread use in the A/E community should force it into the manufacturing world
Inspections	The drawings are checked by the state when a permit is applied for, the fabrication process is reviewed by a third-party inspector (checking trade work), internal quality control inspections are frequent, and the owner will often check progress; therefore, every step of the process is checked and certified before modules leave the factory and liability switches from the manufacturer to the general contractor

*Table 4.4.1 themes and pertinent information identified from the interview with Company D*

**Q:** *To what extent is BIM being used in the manufacturing process today?*

**A:** **All drawings are now done in Revit. It is a requirement for all government projects,** so to remain competitive in the market Company D ran a four-week training seminar for their employees. The only challenges of Revit pertain to the education of the draftsman within the company.

**Coordination has improved due to the use of BIM** because it makes it easy to visualize the project during the design phase which is when issues can collectively (between manufacturer, architect, and the engineers) be identified and resolved. The 3-D model is also a great benefit to the client during design. 2-D printouts are used on the factory floor.

**Q:** *Is there a reluctance among architects to share their drawings because of liability concerns?*

**A:** Sharing of the BIM could (potentially) be an issue for architects/engineers that are developing a proprietary system, yet there haven't been any problems for Company D as of yet.

**Q:** *Who ultimately is responsible for the quality of the model?*

**A:** It varies based on the type of project being done. The model for bathroom pod modules, for example, designed to be set in a site-built building are created in Revit and inserted

into the BIM model, coordinated between the architect and the engineers. The modular manufacturer is solely responsible for the quality of that portion of the model.

**Q:** *What level of automation is being used in the factory today?*

**A:** While there is a limited level of automation used in the steel fabrication shop (cold-rolled steel formations), Company D is a custom builder and automation tends to work best with a commodity-type product where the mass production of components is taking place with a limited number of changes.

#### 4.5 Company E Interview Summary

**Q:** *To what extent are manufacturers involved in the building's design?*

**A:** **Company E is the architect, and tries to maintain control from inception through finishing. This includes financing ventures, identifying land to build on, design and engineering, offsite manufacturing, packaging and shipping, onsite assembly, and construction management for the concrete foundation** (done by a hired contractor).

They are considered an "engineering-to-order" product company rather than a design-build company, and **use a building model program in which the building analysis and design are prepared ahead of time, and capable of being changed accordingly to the specific demands of a client or site.**

**Q:** *Can you identify some general design considerations that are unique to modular construction?*

**A:** **An increased level of specificity in an architect's design is important** for modular construction, requiring drawings to be more detailed.

Shipping and craning concerns will obviously limit design.

**Picking the right manufacturer for the job** is also important because their specialization can vary. It's important to know what the manufacturer is good at, how they do things, what's easy for them, what's hard for them, etc. For example, knowing the skill of the manufacturer in terms of tile and grout work may be important if the detailing of the building calls for expensive and highly precise tile finishes. Looking at the built work done by the manufacturer can provide an understanding of this level of craftsmanship.

**Q:** *Are you always required to produce a set of shop drawings as a supplement for architectural drawings for projects built in the factory?*

**A:** Prefab companies will need to redo or significantly modify the drawings produced by an architect. **Architect's don't produce shop drawings typically because onsite construction involves skilled industry professionals who can interpret a diagrammatic set of drawings.** In industrialized production, where one person is not looking at

the drawings for the whole building, drawings are specific instructions telling factory workers exact installation procedures.

**Q:** *What in-house quality control measures are taken to ensure the precision of component fabrication?*

**A:** Work in an assembly line is checked at every station – **the next person in line checks the work of the previous person.** Secondly, specific quality assurance workers are hired full-time to inspect module construction. Thirdly, a third-party agency comes in and confirms that the work being done is per the drawings. All manufacturers who benefit from the particular codes and allowances of modular construction are required to use a third-party inspection agency.

**Q:** *To what extent is BIM being used in the manufacturing process today?*

**A:** Company E **uses a mechanical engi-**

**neering software for their CAD backbone called CATIA** (developed by Dassault Systèmes). They’ve also **made some custom programmed elements to the software.**

The BIM model is used in the quality control realm, not so much yet in production.

**Q:** *What level of automation is being used in the factory today?*

**A:** CNC roll-forming has been used for a while in the factory. A designer designs the stud layout, and the software sends it to the machine. Stud production includes the punching of holes for plumbing and electrical equipment to pass through them in a wall cavity, as well as installation features (connection points, screw holes, etc.).

**The CNC software developed for the roll-form was developed in-house because the software that came with the machine was inadequate for design.**

Company E also intend on integrating a 3-axis CNC router and a water-jet cutting machine into their building process.

**4.6 Identification of Themes**

Discussions with the five companies covered the following topics of concern in modular construction: negative market perception, the required education of architects for modular building design, overlapping scopes of work, the tendency for drawing duplication, the limited capabilities of CAM software, the challenges at the interface between work done offsite and onsite assembly, and initial building cost restrictions. Overall, the data received revealed specific design considerations as well as a deeper understanding of the manufacturing process in general (both as it compares to onsite construction and how the different modular manufacturers compare to one another). And an understanding of the process then could aid in the pursuit of innovation in design.

Topic	Response
Fabrication Process	<p>Each manufacturer's process is unique, so it is important to see the factory, and to shop for the manufacturer that suits the project</p> <p>Know what a manufacturer is good at, and what type of work is hard for them to do (eg: plan detailed work accordingly)</p>

*Table 4.5.1 themes and pertinent information identified from the interview with Company E*



## **CHAPTER 5: DATA ANALYSIS**

The nature of the data collection procedures – a series of one-time semi-structured interviews – called for data analysis to occur during the development of the questionnaire and in the interviews themselves. Themes revealed during the literature review and from prior discussions with manufacturers influenced the questions asked. The data coding procedures that followed provided direct comparisons of the modular manufacturers' responses. The contents of this chapter therefore reflect upon the experiences of the participating stakeholders and their reactions to the case study project.

### **5.1 Market Perception**

The stigma of low quality and cheap construction associated with manufactured housing has limited the involvement of architects in the modular construction industry. The industry today is focused on providing a comparable building product to a site-built equivalent. Traditionally temporary solutions are complimented with permanent modular

buildings and demountable components for predominantly onsite built buildings. The introduction of modular construction to the consumer as a viable option, however, is generally based on necessity: restrictive sites, expensive labor costs, and time restrictions. They turn to the industry expecting a budget reduced by 15% and a timeline reduced by 30%, and manufacturers are forced to produce \$45 per square foot trailers. So, while modular manufacturers continue to develop \$85 per square foot alternatives that are non-combustible, mold resistant, and re-usable over the course of 20 to 25 years, the public's perception of modular buildings ultimately affects the industry's ability to move forward. A different type of building product altogether should be advertised – an inherently greener process with access to advanced construction technology for both permanent and temporary applications.

#### **5.1.1 Marketing and Outreach**

Design innovation ultimately calls for going

beyond what is possible and what has been done before. First and foremost, this requires both architects and manufacturers to be malleable; open to pushing the established boundaries of their own practices. And secondly, they must understand what those boundaries are.

Outreach programs and marketing dollars currently spent by modular manufacturers are geared towards educating architects. Promotional marketing recognizes built precedents that feature good design, high craftsmanship, and durable materials to establish the possibilities and to garner interest in the industry. The education of the architect on specific factory procedures and fabrication methods identifies the variables and capabilities of the manufacturer's production process. Whatever influence the modular manufacturer has on an architect's design often dictates the allowable materials and structural system. Finally, collaboration between manufacturers and architects on research and development influences industry-wide innovation. This includes investing into new building materials, advanced building systems, and mass customization techniques. Through research of any kind helps both parties to know what questions are being asked and sets goals for the future.

### 5.1.2 LEED

Knowledge of the industry can also be circulated to the public by taking advantage of systems that are already in place for building construction. With LEED (Leadership in En-

ergy and Environmental Design) certification measures encouraging sustainable building processes, modular construction stands out as an alternative to onsite construction because there is presumably less material waste and less site disturbance attributed to the building process. Considering the popularity of LEED today, the establishment of a high rate of certification that can be directly associated with the integration of prefabricated components can be used to quantify the "inherent greenness" of the process.

Sustainability, as it applies to construction, encompasses both fabrication and erection. Coupled with operational policies that do not incur additional expenses (no smoking policy, green cleaning, etc.), LEED certification can be prominently billed as a feature the modular construction industry is equipped to support. Robert Kobet breaks down the LEED points system for new construction as it compares to modular construction in his report *Modular Building and the USGBC's LEED™ Version 3.0 2009 Building Rating System* (2009). 13 different points can be achieved almost automatically by using modular construction. These include the following:

- An Innovation and Design Process credit is automatic.
- Sustainable Sites credits reward limited site disturbance in terms of both duration and affected area, which in itself is one of the primary benefits of building offsite (SS 6.1).
- Materials and Resources credits require

planning on the part of the modular manufacturer to assure that a recycling program is in place at the factory, and that regional materials are being used (MR 2, MR 3, MR 4, MR 5, and MR 7).

- Indoor Environmental Quality/Indoor Air Quality credits are attributed to the fact that the factory provides a safe and well-ventilated environment for workers, and that materials are off-gassed prior to being delivered onsite (EQ 3.1, EQ 3.2, EQ 4.1, EQ 4.2, EQ 4.3, and EQ 4.4).
- LEED for Homes has a Materials and Resources credit specifically for modular construction (MR 1.5).

The final calculations for LEED certification will fall under the architect's scope of work. The modular manufacturer will be expected to write the justification for the innovation credit. They will also need to provide mill certificates for the materials used (type of steel/wood/aggregate), and information on the factory's recycling program. Major government projects have currently adopted a minimum threshold of LEED Gold, though temporary structures are exempt from such considerations.

### 5.2 Education

Interested architects should have a general understanding of modular construction. The shortened construction schedule demands a thorough design development phase including the design and engineering of components, planning of the assembly line, bill of materials and processing of materials, shipping methods, assembly procedure, and even the location

and movements of the crane (if necessary). The effort an architect puts into understanding both specific design constraints unique to each different manufacturer and general design concepts consistent in all modular buildings will impact the effective blending between architectural intent and industrialized production.

### 5.2.1 Building Codes

All modular buildings comply with locally

adopted building codes. The International Codes (I-Codes) have largely been accepted for architectural design and engineering, while zoning, energy and indoor air quality, green building, and historical preservation regulations vary from state to state. Additionally, modular buildings are governed by codes created by the state specifically for the industry. Similar to HUD's establishment of a uniform code for manufactured housing, an organization called the Interstate Industrialized

Buildings Commission (IBC) was developed for the purpose of governing commercial modular buildings. Currently, however, only four states are members – New Jersey, Maine, Rhode Island, and North Dakota. A list of the agencies recognized by each state is provided in *Figure 5.2.1.1* from the Modular Building Institute's *Relocatable Buildings: 2011 Annual Report* (2011, 20). Each is responsible for reviewing building permit applications and drawings, and for certifying third-party inspectors

State	Governing Agency	State	Governing Agency
Alabama	Manufactured Housing Commission	Montana	Department of Labor and Industry
Arizona	Dept. of Bldg. and Fire Safety / Office of Man'f'd. Housing	Nevada	Department of Business and Industry
California	Housing and Comm Division / Factory Built Housing	New Mexico	Construction Industry Codes Division
Colorado	Division of Housing	New Hampshire	State Fire Marshal
Florida	Dept. of Community Affairs / Man'f'd. Buildings Program	New Jersey	Bureau of Code Services / Indust. Bldgs. Commission
Georgia	Dept of Community Affairs / Indust. Buildings Program	New York	Department of State
Idaho	Division of Building Safety / Modular Buildings	North Carolina	Department of Insurance
Illinois	Department of Public Health	North Dakota	Dept of. Commerce / Indust. Buildings Commission
Indiana	Dept. of Homeland Security / Indust. Building Systems	Ohio	Building Codes
Iowa	State Fire Marshal	Oregon	Building Codes Division
Louisiana	State Fire Marshal	Pennsylvania	Department of Community and Economic Development
Kentucky	Department of Housing	Rhode Island	State Building Commissioner/Indust. Bldgs. Commission
Maryland	Housing and Comm. Developmt. / Factory Built Housing	South Carolina	Department of Labor
Massachusetts	Manufactured Building Program	Tennessee	Department of Commerce and Insurance
Michigan	Bureau of Construction Codes	Texas	Industrialized Housing
Minnesota	Dept. of Labor and Industry / Indust. Bldgs. Commission	Virginia	Housing and Community Development
Missouri	Public Service Commission	Washington	Department of Labor and Industry

**Table 5.2.1.1** state departments identified as governing bodies in charge of defining commercial modular building codes (both relocatable buildings and PMC) and certifying third-party inspection agencies (*Relocatable Buildings: 2011 Annual Report* 2011, 20)

responsible for checking the drawings against the work done in the factory. Because interior and exterior finishes are completed before components reach the construction site, modular construction requires periodic third-party inspections to approve works as it passes through the assembly line. Failed inspections halt payment and slow down production.

Fire ratings in modular construction present the most difficult challenge from a design and inspections perspective. Continuous rated construction across component connections and structural member enclosures is needed. Furthermore, ratings for proprietary systems developed for singular projects are expensive and time consuming. Custom cold formed steel fabrications made by modular manufacturers are the most common example.

### 5.2.2 Transportation Limitations

The height, width, length, and weight of components are all restricted by the physical limitations of the truck and the road. A module must be in compliance with the rules of each different state along its path of travel. Modules falling under motor vehicle laws are built on a chassis with an integral hitch and axel. Conversely, components shipped on a flatback trailer qualify as freight and can be shipped as super loads at a higher cost.

The dimensional restrictions of a flatback trailer vary based on the truck used. In general terms, a single drop trailer can handle a 13' x 50' module, but will raise it 3'-2" off of the ground. Alternatively, a double drop trailer (LowBoy)

will raise a module only 2' off the ground, increasing its overall possible height by another foot, but reducing its maximum length to 40'. The maximum height, however, varies from state to state. Modules built directly on a steel chassis, with a detachable hitch, axels, and wheels, can be larger. Modules built of wood construction can be built up to 16' x 80'. The weight capacity of the equipment will however continue to restrict sizes, proportionately reducing the same module built of steel to 16' x 70', or 12' x 56' for concrete construction. The maximum height of modules including the wheels (approximately 3'-6" tall) is 12', though allowable dimensions will again vary by state.

Maximum sizes for oversized loads (requiring a permit) are listed in *Figure 5.2.2.1 (Oversized Load, Permit and Pilot Car Requirements 2011)*. The table reflects the differences in the requirements by state, with absolute restrictions being largely dependent on the route planned – low bridges can be avoided, tree limbs can be cut, and road conditions can be inspected ahead of time. If a manufacturer has multiple factories in different states, shipping through more stringent states can be avoided altogether.

The end building site also influences the design of components. Onsite labor costs vary based on location, so the amount of onsite work will be limited more so for a project in an urban area versus a project done for a rural area. Similarly, the fragility of components is a concern for shipment overseas. The ability for modules to be stacked is necessary on cargo

ships, and while it is efficient to ship large empty volumes to urban areas so that the amount of onsite labor can be reduced, expenses increase exponentially with distance.

### 5.2.3 Tolerances

Tolerances are not built into construction documents. With traditional construction, onsite adjustments are made by skilled craftsmen who can interpret diagrammatic drawings representative of the intended construction. Components built instead in the factory are fabricated as isolated elements, and the factory workers have no understanding of the final building's design. Realistically, the decisions for handling dimensional discrepancies cannot be made competently without knowing how they will affect adjacent components; therefore there is a higher level of detail put into shop drawings to prevent such guesswork. Tolerances added to the drawings provide a window in which the dimensions of a component can vary. Material imprecision makes it impossible to use absolute dimensions. Minor differences from one component to the next include rough finishes, warped materials, and unaccounted material thicknesses (eg: glue, grout, or paint finishes), all needing to be accounted for in dimensioning. With the quality of work that can be expected in the factory, tolerance levels do not have to exceed 3/8" to 1/4". This applies at both the detail level within each module, and at the macro level within the context of the entire building.

### 5.2.4 Means and Methods

The amount of influence the manufacturing

State	Width	Height	Length	State	Width	Height	Length
Alabama	12'	16'	76'	Montana	16'-6" *	17'	110' *
Alaska	*	*	*	Nebraska	12'	14'-6" * (16' *)	100'
Arizona	14' (*)	(*)	120' (*)	Nevada	12' * (17' *)	17'	105' (*)
Arkansas	12' *	15' (16' *)		New Hampshire	12' (14'-6")	13'-6" (*)	80' (100')
California	12' * (16')	(16' *)	85' (135' *)	New Jersey	14'	14'	100'
Colorado	*	*	*	New Mexico	14' * (20' *)	16' (18')	90'
Connecticut	12'	14'	80'	New York	12' (16' *)	14' (16' *)	80' (140' *)
Delaware	12' (15')	15'	85' (120')	North Carolina	12' (15')	14'-5" (*)	100' (*)
District of Columbia	12'	13'-6"	80'	North Dakota	14'-6" * (18' *)	18'	120'
Florida	12'	14'-6"	95' *	Ohio	13'	14'-6"	90'
Georgia		15'-6" *	75' *	Oklahoma	12' *	15'-9" *	80'
Idaho	12' *	16'	100' *	Oregon	14'-1" (16' *)	14'-6"	120'-1" (150')
Illinois	14'-6" (18')	14'-6" (18')	110' (175')	Pennsylvania	13' (16')	14'-6"	90' (160')
Indiana	12'-4" (*)	14'-6" (*)	110' (*)	Rhode Island	12' (*)	14' (*)	80' (*)
Iowa	14'-6" *	14'-4" (*)	120'	South Carolina	12'	13'-6"	
Kansas	12'-6" *	*		South Dakota	10' *	*	
Kentucky	10'-6" *	*	75'	Tennessee	12'-6" *	15'	85'
Louisiana	12' * (16')	* (13'-6" *)	90' (125')	Texas	16' (20' *)	17' (19' *)	85'
Maine	12' (16')	*	80' (124')	Utah	12' (17')	16' (17')	105'
Maryland	13' (16')	14'-6"	85'	Vermont	12' (*)	14' (*)	80' (*)
Massachusetts	12' (15' *)	13'-6" (13'-11")	80' * (130' *)	Virginia	10' *	*	85' *
Michigan	12'	14'-5"	100'	Washington	15' *	14'-6" *	100'
Minnesota	14'-6" (16')	*	95'	West Virginia	10'-6" * (16' *)	15' *	75' *
Mississippi	14'	*	95'	Wisconsin	14' * (16' *)		125'
Missouri	12'-4" (16' *)	15'-6" (16' *)	90' (150' *)	Wyoming	14' *	17'-6"	110'

Note: Rules of thumb for the requirement of an oversize load permit: 8'-6" width, 13'-6" height, 48' length, or 80,000 lbs

\* Determined entirely by route travelled

XX Indicates maximum possible dimension without a pilot car escort

() Indicates maximum possible dimension without a police escort/state review

Table 5.2.2.1 transportation requirements by state (Oversized Load, Permit and Pilot Car Requirements 2011).



Figure 5.2.2.1 example of a module on a double-trailer bed

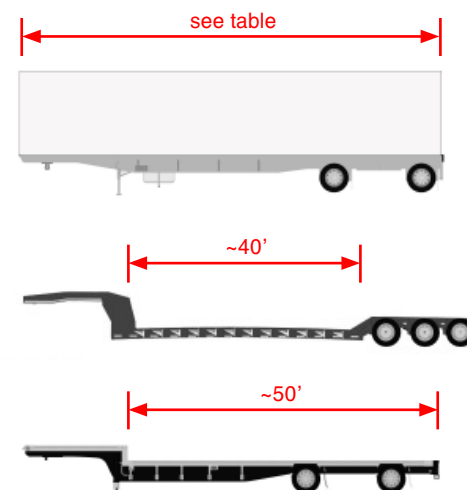
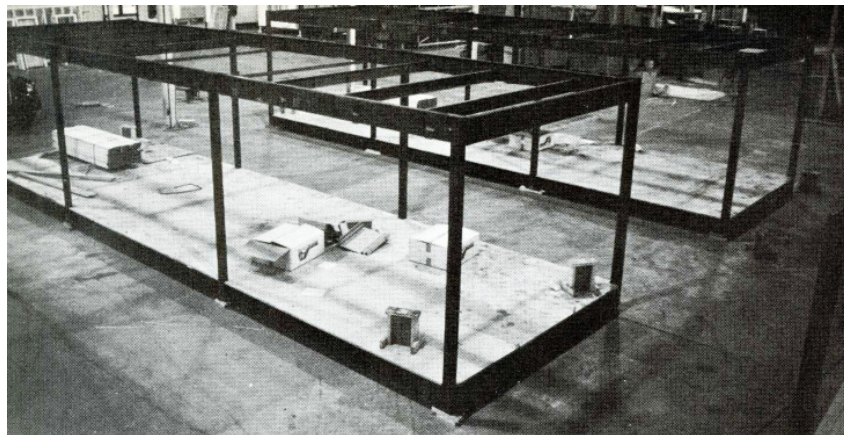


Figure 5.2.2.2 comparison of maximum module lengths base on different shipping methods

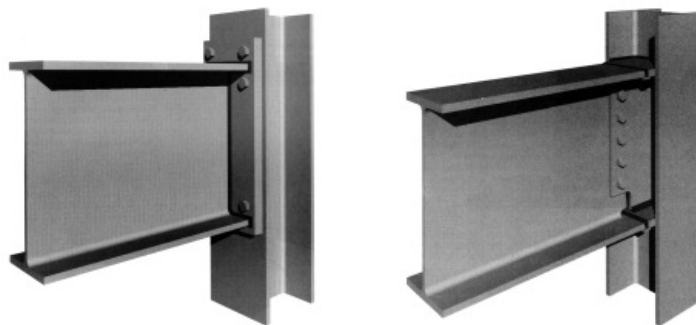
process has on design decisions highlights the need for architects to be educated on how different modular manufacturers operate. The service provided by manufacturers varies based on the materials that can be handled in the factory, the experience and specialization of the workers, the technology available and the level of automation used, and the preparation of drawings and standards used for inspections and approval.

The standard structural system developed for volumetric modules is expected to have the greatest impact on how a building should be divided into components as well as the installation procedure (generally including attachment points for crane lifting in place). Transparency on the part of the manufacturer regarding their structural design and dimensional limitations is necessary; otherwise a complete re-design once the manufacturer is finally on board should be expected. The scope of work a modular manufacturer is willing to undertake also depends on the capabilities of the factory. For example, some will exclusively engage in design build situations where they are responsible for hiring the architect and the onsite contractor (if needed) and will see a project through to its completion. Others will contribute more to hybrid projects, fabricating bathroom pods, façade components, structural panels, or party walls.

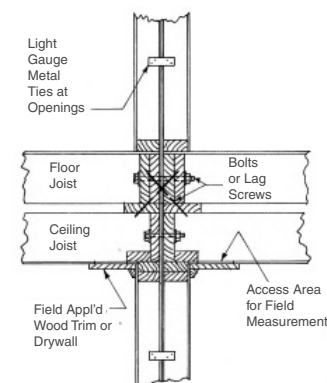
In the end, finding the right manufacturer for the job is largely influenced by cost competitiveness and the quality of work. The relationship different modular manufacturers



**Figure 5.2.4.1 common module structure:** The typical steel structure for modules is a 3-dimensional vierendeel truss which will allow for stacking arrangements. The difference, however between the structural design of Company C from Company B is that vertical steel columns are temporary and can be removed after onsite installation. Company E, uses hinged ceiling and wall panels connected to the structure in order to reduce module sizes, while Company A will primarily stick build on a steel chassis (resulting in unstackable units) (Reidelbach 1971, 126).



**Figures 5.2.4.2 and 5.2.4.3 steel connections:** A vierendeel truss uses moment connections in place of diagonal bracing members. Moment connections rigidly connect the web and flange of W-shapes with either a welded or bolted joint (Allen and Iano 2004, 392-394).



**Figure 5.2.4.4 module cross section:** Module structures commonly result in material redundancies creating thick interstitial space between floors (Reidelbach 1971, 137).

have with wholesale providers can work to drive costs down. They'll generally use local products obtained at discounted rates, or products volume purchased in the design of their buildings. Beyond cost competitiveness, an understanding of what a particular manufacturer is good at requires a study of their previous work. In doing so, the quality of construction (tile and grouting, architectural concrete finishes, decorative welds, etc.), the diversity in the projects undertaken, and the volume of the work they can handle all can be measured.

### 5.3 Scope of Work

The quality and cost effectiveness of modular construction is dependent on a coordinated design effort. Part of this is because additional communication between all parties makes the transition between trades easier. That way, responsibilities are defined and understood before work is passed along, preventing overlaps in the work done by different parties. This is also because the experience of manufacturers can be used to aid the design process. Buildings can be productively value engineered – cost effective construction within the confines of the design intent – with early design collaboration. The problem is that a lengthy design development phase is not often built into modular building projects because of the accelerated schedule. The architect's scope of work is identified in the written contract.

A traditional design-bid-build contract is an arrangement in which the architect is hired directly by the client to create a design for

the client. The competitive bidding process follows once a design is established where the architect and the client search for a suitable modular manufacturer and onsite general contractor. Such bidding offers the greatest cost savings, but increases the time to completion and can compromise quality. The gap between the selected manufacturers and general contractors is the greatest in a design-bid-build contract because they do not have a professional relationship, so extra care is taken to define separate scopes.

With the design-build scenario, the client hires the architect, the manufacturer, and the general contractor as a preassembled team (or one entity having capabilities for all functions), who collectively assumes responsibility for both design and construction. A collaborative design effort is typically preferred by modular manufacturers because each has its own system for the design and construction of modular frames. Building costs are more rigid since there is no competitive bidding process involved. The relationship of the architect, manufacturer, and general contractor is established in previous projects making quality assurance predictable. The design-build contract is most common when an established prototype design is in place. Prototyping is done to allow the architect or the client to test a design concept before a large volume of work is done. Prototyping in the factory can replicate the anticipated production process and craftsmanship, permitting the efficiency of the process to be critiqued as well.

A negotiated bid contract combines the cost effectiveness of a design-bid-build project with the quality of craft of a design-build project. It is a situation in which the modular manufacturer is selected at the beginning of the project, making them in charge of controlling the budget, hiring the architect and onsite general contractor, and coordinating the design effort.

The inevitable challenge in defining scope of work is in balancing what someone is good at and what is most cost effective – also known as procurement. A modular manufacturer will have more control over quality and construction speed with more work done in the factory and components being shipped as large finished modules. Adversely, some may argue that modular construction takes away from the economic development of the local community, and that the requirements for shop drawings will affect an architect's commission by lessening or altogether eliminating the need for construction documents.

Each contract structure has different advantages. For example, the needs for custom projects differ significantly from standard, pre-designed projects. So at the beginning of each project, the roles and responsibilities of all collaborating parties must be carefully considered.

### 5.4 Drawing Duplication

Construction documents are the coordinated set of drawings agreed upon by all trades – including the architect, the structural engineer, and the MEP engineers. The drawings outline

design intent and are adequate for onsite construction, but are generally inadequate in a manufacturing process. Shop drawings are created specifically for manufacturing processes. They double as the set of commands handed to builders and as the architect's check of the work that is expected to be done. The drawings are produced by the manufacturer and are developed to their preferred format. When a preliminary set of drawings is first completed before a manufacturer is brought onto a project, duplicate drawings are usually produced.

#### 5.4.1 Shop Drawings

Factory workers will manage all of the work for a particular task (walls, floor, roof, structure, etc.) depending on the volume of work passing through the factory. The shop drawings reflect the precise requirements of the task at hand. They're additionally used for third-party approvals, and for a financial check, representing expected material orders. Drawings issued on the factory floor are limited to the individual activities performed (on sheet per station), preventing time being wasted searching for the appropriate drawings.

The best way to prevent duplicate drawings from being produced in the shop drawings set and the construction documents set requires early coordination and constant dialogue throughout design development. Most architects are unaccustomed to the detail required for shop drawings, and factory workers lack a familiarity with different drawing formats. Drawing collaboration through BIM

(Building Information Modeling) provides distinct advantages in both regards. Three-dimensional screenshots and walkthroughs can be easily created for the client's benefit, while pre-defined sheet layouts with dynamic dimensioning and scheduling can appropriately capture the detail required for factory production.

#### 5.4.2 BIM/3D-CAD

BIM more specifically is the representation of a design as parametric objects in five-dimensions. Objects are thereby defined as parameters and relations to other objects, such that changes are made consistently throughout each different view, requiring only a singular action. The information accumulated with the building model – including design data, geospatial information, construction phasing, product information, financial and legal data, mechanical, electrical, plumbing layouts, etc. – serves as a shared knowledge resource for information about a building, forming a reliable basis for decisions throughout its lifecycle (Neelamkavil 2009, 4). In a recent study, the National Institute of Standards and Technology (NIST) listed the emergence of BIM technology as a factor fueling interest in the modular construction and prefabrication industries (Bernstein, Gudge, and Laquidara-Carr 2011, 28).

The centralized database of all building information in a 3-D model is one of the primary benefits to using BIM. Modular manufacturers that use BIM for their production and inspections processes, however, have insisted

that they instead prepare the model like they prepare their shop drawings. Separate models are made for each component type (panel, modular system, or module). This is primarily due to the size of drawings files. Such component objects are “over modeled” against conventional wisdom incorporating every bolt and screw so that they can be understood on the factory floor. The use of an actual live model in which all design parties make their own additions is really only possible in a large design-build outfit where everything is done in-house. A working BIM contract is needed to define the level of detail each contributor is expected to provide, and the parties responsible for developing specific model content. With the E202-2008 BIM Protocol Exhibit document, the AIA has taken the initiative for defining the Level of Development (LOD) and the Model Element Author (MEA) serving these functions, although it is not currently a required addendum for BIM projects.

#### 5.4.3 Paperless Production

The use of the BIM model on the factory floor as a supplement to the shop drawings and for inspections of craftsmanship and accuracy raises the potential for a completely paperless production process. This however requires more time upfront to develop a comprehensive 3-D model, more so than the time required for an accurate 2-D set. For instance, even if mechanical ducts and plumbing lines are to be concealed within floor and ceiling plenums, time is still invested into their representation in 3-dimensions so that workers can accurately judge how and where systems cross mate

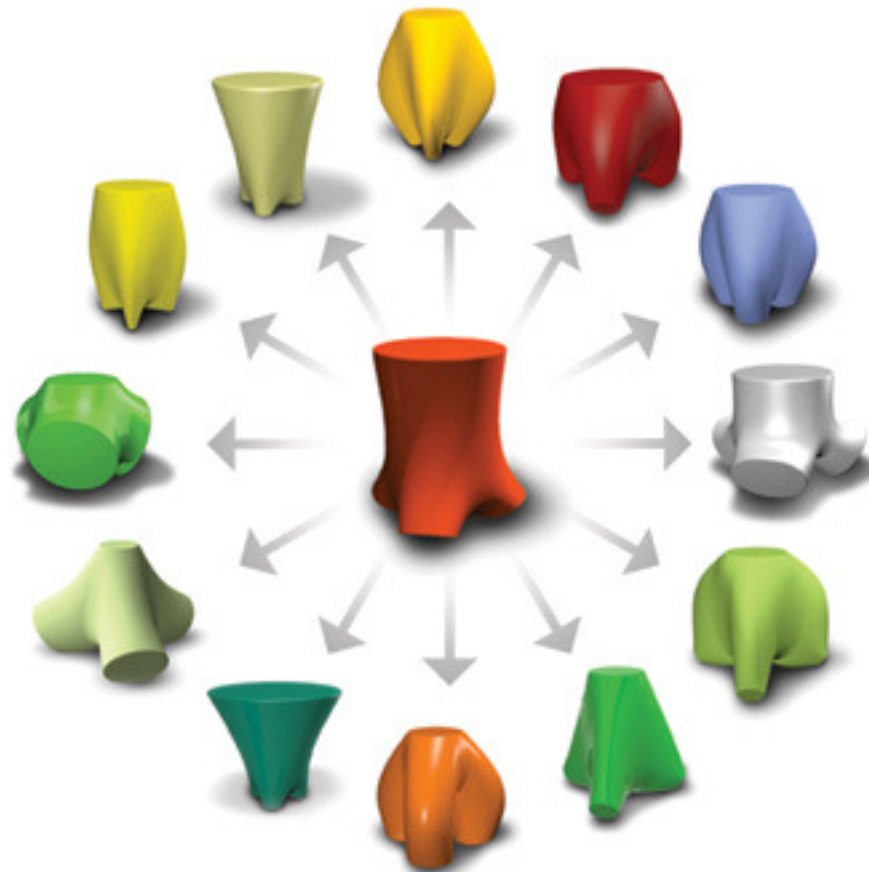


lines. Another challenge is the legal approval process because the shop drawings are currently the only documents that will stand up in court as the argument for completed work. The dimensions on the shop drawings are historically considered the commands for construction; there is no precedent for the BIM model being a legally accountable entity.

### 5.5 Impediments to Mass Customization

The ability of CAM tools today to produce custom fabrications without human intervention makes the utilization of CNC (Computer Numeric Control) devices and advanced robotics desirable. CNC connects CAD and CAM visualization programs with machine tools. Such programs write the commands for interpretation by the machinery. Robots similarly run on CAM programs and operate in over 5-axes, featuring agility capable of complex actions. At the component level, simple task-oriented processes like CNC cutting, milling, and pressing, and robotic welding or drilling, all can be completed in fixed locations while posing minimal challenges in handling. Full automation further requires more complex sensor dependent robotics for movement to perform such tasks as column positioning, floor and floor cage laying, cladding attachment, beam placing, partition placing, ceiling cage placing, and floor grouting (Ibañes-Guzmán et al. 1990, 88). Any level of automation requires sustained volume, particularly at startup because of upfront costs.

Mass production is about repetition; volume building using identical processes to increase



*Figure 5.5.1 stool design by Patrick Chia: An example of mass customization in industrial design: variations in this stool design are not executed through hand craft, but by mechanical means (Piller 2006, 6).*

labor productivity and the cost effectiveness of construction. The notion of mass production can be promoted for fleet buildings which are rented for temporary uses, but in most cases the site, program, architect, and client will each dictate unique requirements. Modular construction does, however, provide the opportunity for economies of scale to be introduced into design so that isolated elements of a building can be produced in volume. Economies of scale maximize the use of both stock materials bought in bulk and processed materials prepared regularly in the factory.

Mass customization takes advantage of the cost benefits of an automated production process without compromising variety. In an assembly line, each station introduces a different system or material, making it possible to isolate like processes for mass production (Kieren and Timberlake 2004, 63). When automation is introduced to the process, component modifications will typically contribute to increased production time and costs. The concept of mass customization revolves around the notion that CAM tools can be designed to incorporate machine fabrication technologies while still providing flexibility for individual customization.

Architects are ahead in the notion of mass customization where “custom tweaking” can be manipulated easily in design programs through dynamic scripts (Grasshopper, Revit, 3D Studio Max, etc.). The software associated with machining processes is not nearly as advanced. There is a difference in

the sophistication of the advanced technology available and the software used to operate the machines. Consequently, automation is used currently for completely repetitive processes, as even minor changes skew repetition and involves intensive code modifications. CNC and robotic tools purchased are packaged each with their own CAM software, also lacking the consistency available with CAD. Modular manufactures are thereby forced to write their own software unless adequate information can be extracted from BIM model databases.

Any change to the repetition of parts slows down production because of the “human factor.” Beyond the software modifications, the handling of a large number of parts (particularly the more they are differentiated), the slower the workflow goes. Therefore, until the entire process is fully automated, including assembly and not just the making of the parts, the concept of mass customization will be hard to achieve. And without the level of volume available in the automobile industry, it is hard to make full automation cost effective because the variation in modular construction is much greater than in the automobile industry.

### **5.6 Offsite/Onsite Interface**

The difficulties at the transition from offsite modular construction to onsite construction (including foundation, site-built features, and component assembly) extend beyond the scope of work definitions. An onsite general contractor, often hired separately as a local contributor to the project, needs to understand what will be delivered to the site from the mod-

ular manufacturer and how it should be handled. This is accomplished in some instances by the general contractor visiting the factory, or the modular manufacturer sending their own project manager to the site. Coordination through notations on the drawings, with sections of the full building clearly identified as offsite work or onsite work, is the only requirement for state approval. Early planning on the part of both the delivering party and the receiving party is however critical in developing the order in which modules are delivered and installed so that damages to the modules or putting workers in dangerous situations can be prevented.

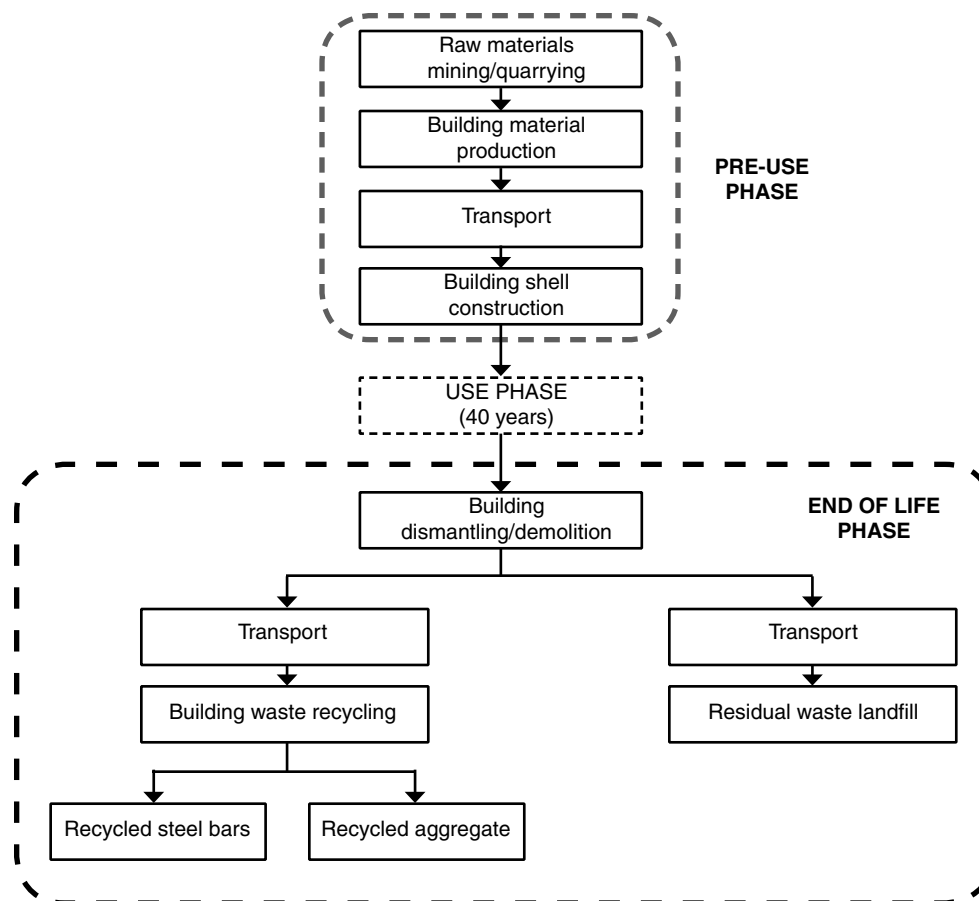
The term mate line refers to where modules are connected onsite. Finishing of components built offsite is typically necessary to cover the seams, with materials (including trim and drywall) shipped in the empty volume of the modules by the manufacturer. The effects of unfinished seams on the interior or the increased labor required for finish work required onsite present an example of the decisions architects will have to make regarding installation procedures. Pulling back finishes at the end of modules so that full wallboard segments can be used can prevent irregularities in their rhythm across a large span, while avoiding mate lines crossing restrooms ensures consistency in the quality of tile finishes.

An architect must consider the consequences of integrating a modular manufacturer’s structural system when developing the drawings. There are going to be structural redundancies an architect might not anticipate.

Particularly prevalent in multi-story buildings, the relationship of the roof structure of the lower module to the floor substructure of the top module presents a cross section unique to modular buildings. The result complicates the division of work. When systems cross mate lines, access for quick connections and plug and play wiring dictates that ceiling finishes and sprinkler pipe installations should be done onsite; and if a great deal of foot traffic is expected from onsite construction workers, floor finishing will be saved until the very end. When the building has an expected completion percentage (an 80-20 rule limits onsite construction costs to 20% of the total bill of construction) clearly identified in the manufacturer's contract, these issues in the design of the fabrication and erection processes become a concern.

### 5.7 Initial Building Costs

Materials being specified by architects are taking into account the life cycle value of materials (durable) and components (re-usable). Life cycle costs are attributed to the amount of energy and resources invested into materials and assemblies. This encompasses the goods and services used for the extraction of materials, their refinement and integration into components, the re-use of the components, the disassembly and recycling of materials, and their final disposal. The life cycle assessment method is the standard for comparing materials, components, systems, and entire buildings (Itard and Klunder 2007, 254). Ideally, the consideration of expenses accumulated from cradle to the grave can justify



*Figure 5.7.1 the life cycle value of materials: A demonstration of the effort and resources put into the life of a building from cradle to the grave (Blengini 2009, 322).*

durable construction for components that can be re-used.

Component re-use, building portability, and the life cycle value of materials do not currently compensate for higher initial construction costs. So while the ability for components to be interchangeable, replaced, and re-used is not a challenge from a production standpoint, feasibility is decided by cost. Customers expect cheaper buildings. The strategy manufacturers employ focuses on the financial benefits of construction speed in comparison to a fully onsite constructed building: either by reducing the costs of displacing workers, or through the opportunity to turn profits sooner.

It is possible that costs saved in construction through time savings are offset by transportation costs. Savings are then sought through material optimization, labor efficiency, and value engineering. Material optimization is a byproduct of labor efficiency and value engineering, but factory production is conducive to material savings attributed to fewer incidents of component damage, error, and theft. Labor efficiency and accuracy are aided by a system of jigs and fixtures. A fixture is a device that positions materials or formwork, and a jig controls the movement of the tools so that duplicate actions are done with precision. Value engineering identifies and removes unnecessary expenditures, maximizing the value of the building with early design collaboration.

The other option for investment into expensive

construction is through third parties. Modular building distributors or dealers will volume purchase a fleet of relocatable buildings from a wholesale manufacturer in a similar fashion to the way that a car dealership operates. This way a building (or components that comprise a kit of parts) can be leased for multiple temporary functions throughout its life. With that in mind, it is within the realm of possibility for an evolving building kit of parts to exist as a demountable structure which can be taken down and reattached easily.

## CHAPTER 6: CONCLUSIONS

The objective of this study was to clearly present the barriers and the design limitations placed upon architects by the building manufacturing process. Ideally, this would lead to future investigations that propose ways to overcome these obstacles.

### 6.1 Interpretation of Data

From a production standpoint, the feasibility of the case study project was not a concern of the participants. Their concern was for its cost. SIP's fabrication in-house would require re-tooling or a dedicated factory responsible for their production. So the panels would instead be outsourced to a specialized manufacturer unless an adequate volume is demanded. Similarly, if the manufacturer isn't already capable of forming their own cold-rolled steel shapes, those too would be outsourced. The responsibilities of the modular manufacturer would thereby reduced to the services of purchaser, inspector, and planner. Manufacturers are therefore hesitant to explore changes to their production lines because

it's costly to do so (re-tooling, education of the workers, and increased coordination with architects).

This issue of the cost of production is an example of a barrier, or an obstacle to design innovation in the modular construction industry. A constraint is a restriction or limitation serving as a bottleneck that forces the designer's hand throughout the decision making process. The following constraints that were uncovered in this study:

- 1) The lack of knowledge of manufacturing processes among architects
- 2) Module size and weight limitations based on shipment method and the designated path of travel
- 3) The effects of the manufacturer's means and methods of production on the design of a modular building
- 4) The higher level of detail and the time commitment required upfront for the development of shop drawings

- 5) How the approach to the procurement of work affects the responsibilities of involved parties
- 6) The knowledge of coding needed for the use of CAM-operated machines limiting the use of automation in the factory

The two barriers identified from this study include the following:

- 7) Negative market perception based on built precedents
- 8) High initial costs compounded with a lack of awareness among clients of the potential long-term financial advantages

The conclusions made in this chapter are interpretations of the data made by the researcher. The experiences gained through participation in the design of the case study project, through the literature review, and through the conversations with industry professions all have influenced the identification of the problems and the suggestions that follow.

### **1) The lack of knowledge of manufacturing processes among architects**

The data collected in this study stressed the desire of manufacturers to educate architects, informing them of what is and what isn't possible through modular construction. This can vary from manufacturer to manufacturer because their processes differ, but an architect should have a general understanding of the following:

- *The fabrication process:* Work is typically divided into stations combining similar tasks, allowing the construction of different parts to be done in tandem.
- *The third-party inspections and approval process:* Drawings clearly defining what will be done in the factory versus what will be done offsite are submitted for state approval. Internal quality control measures are conducted at each station, which can include visits from the architect and/or client. Finally, a third-party inspector is hired to make sure that the work done is per the drawings.
- *Transportation methods:* Module sizes vary based on shipping method and the path of travel of components.
- *Onsite assembly procedures:* The movements and location of the crane, the sequence of module installation, and the necessary points of connection for handling must all be planned ahead of time.
- *The cross section of a modular structure:* The structure of the modules will be designed by the modular manufacturer, and each has its own standard details. So it is important to know how modules will relate to one another in regards to structural redundancies and the resulting effects it will have on the overall size of the final building.

A lengthened design development stage is common with architects not familiar with the process of modular construction. Measures that could be taken to educate architects include the following:

- Continuing education seminars sponsored by LEED, the AIA, and NCARB offer opportunities for manufacturers to interact with architects before working on projects together. Similarly, teaming with students through design charrettes and sponsored competitions provides the manufacturer with insight into the interests of architects while providing architects with experience working on modular buildings.
- Tutorials built directly into CAD software, providing immediate access to information regarding the general constraints and design limitations of modular construction.
- Dynamic scripts written for Revit designed for immediate “conflict detection” so that drawings conform to the dimensional restrictions and code-related regulations of different states.
- Shared design responsibilities between the architect and the manufacturer, including either a scenario in which the architect relinquishes control after schematic design, or a collaborative design effort from start to finish. The latter requires a dedicated staff of designers working directly alongside the manufacturer and a shared server.
- Incorporate integrated project design and delivery methods (IPD). IPD is a team-based approach to design and construction. More so than in a design-build scenario, collaboration is optimized because the major disciplines (including architect, manufacturer, general contractor, and specialized subcontractors) form either a single entity or a strategic partnership (Integrated Project Delivery – A Working

Definition, 1). The architect is immersed in the manufacturing process, paving the way for future certified modular architects.

## **2) Module size and weight limitations based on shipment method and the designated path of travel**

Fabricating components offsite immediately raises into question the mode of transportation available for shipment. Savings accrued from the fabrication process are often offset by transportation costs, so it is important to capitalize on the most cost-effective solution when deciding the size and structure of modules. The following are all factors affected by transportation constraints:

- Modular structures transported on a flat-back trailer will be limited in length, width, and weight based on the physical capacity of the truck.
- Components fit into shipping containers are best suited for projects overseas because the structural integrity of the containers allows for unorganized stacking. However, components will be limited by the interior dimensions of the container in length, width, and height.
- A modular structure built on a steel chassis with an integral hitch, axels, and wheels will have to fall within the maximum dimensions defined by state law.
- Oversized loads or “superloads” can still be shipped at higher costs, so it is important to know what the consequences are to exceeding the allowable state dimensions

(eg: larger escorts, special state approval). Superloads are also more susceptible to unplanned roadblocks created by highway construction, even if the path of travel is inspected in advance.

## **3) The effects of the manufacturer’s means and methods of production on the design of a modular building**

For the manufacturers interviewed there were significant differences between their fabrication processes:

- Company A builds isolated modules which are not combined until final assembly.
- Company B builds a monolithic structure offsite, which is broken down into modules once completed.
- Companies C, D, and E have introduced BIM into their production lines, allowing automated machines to be used by extracting information directly from the models.

The structural system and subsequent detailing of modules will usually fall under the manufacturer’s scope of work. This will have the most significant influence on the form of the final building. The differences in the structural systems of the five companies interviewed include the following:

- Company A primarily stick builds directly on a steel chassis resulting in unstackable units, and uses an adhesive spray foam to reduce the number of screw and bolt

connections.

- Company B builds a “steel cube” structure with temporary columns that can be removed after onsite assembly is completed.
- Company C employs a 3-dimensional steel vierendeel truss which allows for stacked arrangements.
- Company E uses hinged ceiling and wall panels connected to its steel structure in order to reduce module sizes.

Therefore, it is critical for an architect to “shop” for the appropriate manufacturer. The challenge to “shopping around” is that the capabilities of each modular manufacturer are not immediately known.

This lack of transparency regarding the means and methods of construction can be considered a constraint to design innovation. To improve transparency, the following steps could be taken by manufacturers:

- Create an online virtual presence providing typical structural details, material specifications, and 3-dimensional models for immediate integration into BIM projects.
- Adopt industry standards applicable to different materials used. Standardized connections and detailing prevent confusion in design development and onsite assembly. Proprietary structural frames will vary between manufacturers, but industry-wide standards would assist in design decisions related to fire-rated assemblies and forklift

or crane attachment points.

**4) The higher level of detail and the time commitment required upfront for the development of shop drawings**

Shop drawings are usually created in addition to construction documents. This duplication of work illuminates the fact that an architect's construction drawings are typically unsuitable for modular construction.

To improve efficiency, shop drawings and construction documents should be merged. To make this possible, the following information must be accounted for in the drawings:

- Work done in the factory versus work done onsite must be clearly defined in drawings depicting the full building form.
- Shop drawings are the explicit directions for building components. The location of every screw, bolt, and layer of glue must be accounted for in the drawings. This also applies to the mechanical and electrical drawings, where the detailed representation of wall and ceiling cavities defines how systems cross module mate lines.
- Global and component-specific tolerances built into the drawings are used to account for discrepancies in material thicknesses and field measurements. Building some form of allowance into the design can prevent future onsite assembly issues.
- Drawings issued on the factory floor reflect the task of a single worker. The workers

at each station are therefore not issued the full set, nor are they familiar with jobs outside of their scope of work. Drawings must be coordinated with the stations of the assembly line, providing a comprehensive set for each individual component.

Spending more time upfront on detailed drawings would ultimately improve efficiency, increasing speed and decreasing overall cost. To prevent drawing duplication, it is suggested that one of the following actions is taken:

- Restrict the role of the architect to developing the façade “look” and the plan layout, as suggested by the Modular Building Institute (*About Modular Construction*).
- Use a live BIM model shared between the architect, engineers, modular manufacturer, and onsite general contractor. Using BIM as a tool for optimizing productivity is first dependent on the contract written. The contract must define the level of detail and ownership of model elements so that the expected contributions of the involved parties are understood. Second, the detail built into the models must adequately capture the explicit composition of components so that the bill of materials can be generated. To facilitate coordination, unique identifiers can be assigned to each object in the model, providing appropriate feedback tracking (GSA BIM Guide 2007, 21). The real-time tracking of progress made in the factory helps the architect make

additions, comment, monitor pricing data, and update the schedule from a remote location. Finally, sheet layouts, schedules, and standard details can be packaged with files for cross-discipline use.

- Engage in a collaborative design effort, preventing scope of work overlaps.

**5) How the approach to the procurement of work affects the responsibilities of involved parties**

Due to the design-build nature of modular construction, a close partnership between manufacturer and architect is needed at the outset of a project. Therefore, the traditional design-bid-build contract structure is not always the best solution. The competition for work will likely be more of a struggle because there are going to be three parties involved instead of two. For example, more work done offsite would give a greater degree of control over the speed and quality of construction to the manufacturer, but will decrease the contribution of the onsite general contractor.

In order to optimize workflow, architects must have an understanding of the common methods of procurement which are:

- *Design-bid-build*: A competitive bidding process takes place after a design by the architect has been approved by the client. This results in a greater disconnect between parties.
- *Design-build*: The architect, modular manufacturer, and onsite general contractor



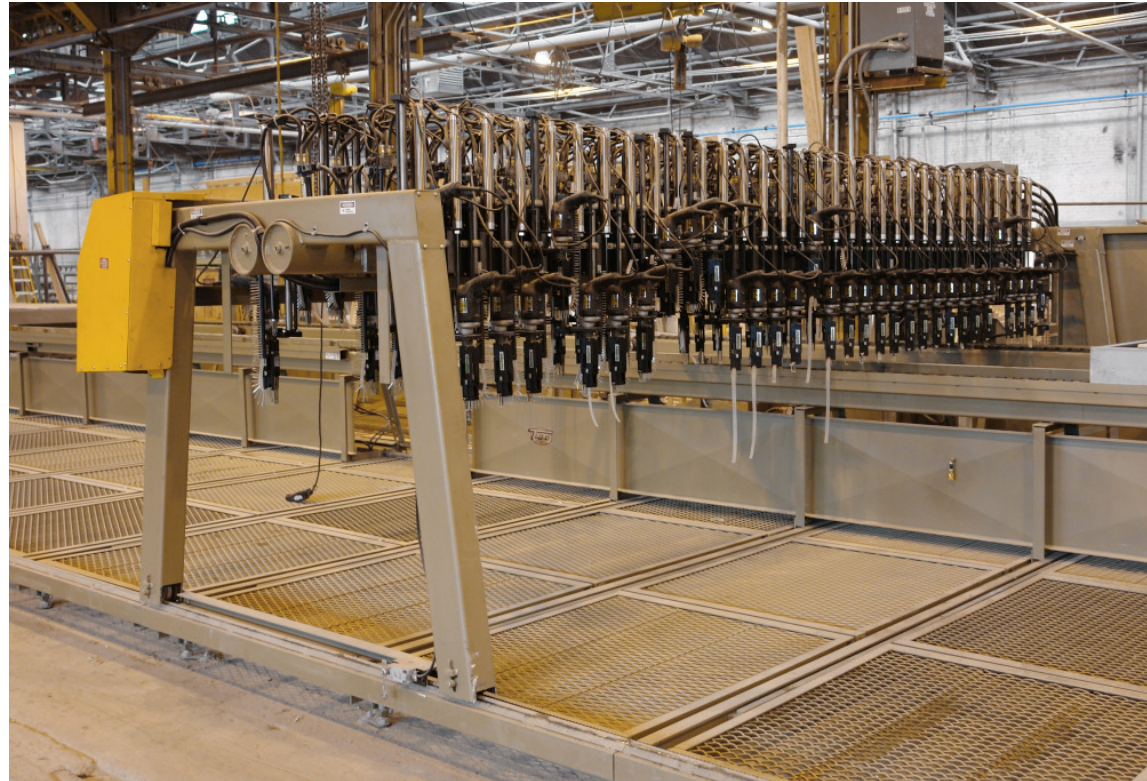
are hired as a team, and assume the responsibilities of design and construction together.

- *Negotiated bid*: The modular manufacturer is hired first by the client to find the appropriate architect and onsite general contractor that can be hired within the constraints of a budget.
- *Certified Modular Architect (CMA)*: The participants in this study encouraged a sustained relationship between an architect and a manufacturer developed over multiple projects. Therefore, a certification process providing training and continuing education can be introduced to the modular building industry. An architect intimately familiar with modular construction is best suited to handle coordination issues that arise when work is being done in the factory and onsite simultaneously.

**6) The knowledge of coding needed for the use of CAM-operated machines limiting the use of automation in the factory**

The availability of CAM-operated machinery brings into question whether or not an industrialized process can be applied to building construction similar to the way in which automobiles are manufactured. There is, however, a low degree of automation currently used in site-built construction because of the following factors (Martinez et al. 2008, 134):

- The traditional nature of the industry is slow to evolve.
- The inherent uniqueness of building design



*Figure 6.1.1 Triad/Ruvo automated machine for steel wall and floor panel fabrication (Deluxe Building Systems 2009)*

defined by the individual client and site, and the lack of standardization of parts makes mass production impractical.

- The work environment is constantly changing based on the type of project undertaken.

Modular construction provides the most static work environment, dividing construction into a series of isolated tasks. A fully automated manufacturing process is contingent on a high volume of demand, a level of which is not typically available in building construction. Therefore, the application of dedicated machines towards singular tasks is instead pursued where possible.

The problem is that CAM software today is generally inadequate for the manipulation of work for custom projects. Such programs do not have the capacity for customization that CAD software has, so repetition is critical.

Architects are drawn to the concept of mass customization in modular building design being able to automate a custom kit of parts with interchangeable components that can be plugged into a constant structural system. For this to be possible, the following must occur:

- The design must strategically plan the use of technology available in the factory, maximizing the repetition of parts that can be fabricated by mechanical means.
- CAM software must be brought to a level of customization similar to that available in CAD programs. For example, Grasshopper



*Figure 6.1.2 component assembly line (Reidelbach 1971, 154)*

(a plugin for Rhino) maximizes “tweaking” through the use of generative modeling, making scripting more accessible to the user by giving it a visual component. Conversely, most CAM programs are usable only at the database level requiring an understanding of coding.

### **7) Negative market perception based on built precedents**

Although the nomenclature used throughout the industry is not consistent, the type of products produced by a manufacturer can be categorized as either relocatable or Permanent Modular Construction (PMC). Architects are more likely to be involved in PMC projects, but the percentage of new construction projects utilizing modular components is currently under one percent. The challenge then is to increase the level of integration of modular components in construction despite poor market perception.

The negative connotation associated with modular construction comes from the association of poor and unsafe construction with the industry. Historically, the industry was geared to build temporary building solutions for immediate needs. These buildings, which were built for only three to five years, were used for permanent applications. Today, the industry recognizes the need for durable construction for even temporary uses, making it possible to move and re-use full buildings. So, a lack of knowledge among consumers as to what is possible can prevent design innovation.

In order to overcome the stigma sometimes associated with modular construction, manufacturers attempt to offer a built product indistinguishable from one built onsite. Therefore, the industry advertises a direct alternative to onsite construction. In a comparative analysis of the two processes, time savings and worker safety stand out as the primary advantages of modular construction over onsite construction. The building manufacturing process itself, construction in a controlled environment with access to advanced technology, is an evolution of the art of building, which is traditionally slow to evolve. The modular building industry therefore should advertise a different building product altogether, featuring design innovation and ingenuity executed through advanced building techniques.

The following merits of modular construction should be prominently featured:

- The industry’s claim of being a more sustainable construction process should be backed by a high rate of LEED-certified projects.
- The reusability of demountable components raises the re-sale value of building parts, or even whole buildings, that can be replaced, recycled, or moved based on need.
- Access to CAM-operated machines limiting human intervention improves craftsmanship and production speed, while enabling complex forms and assemblies to be produced.
- Factories are likely open to experimenta-

tion and research, making manufacturers quick to adopt new fabrication techniques and building materials.

### **8) High initial costs compounded with a lack of awareness among clients of the potential long-term financial advantages**

The issue of production costs will always be a barrier to innovation in modular construction because both the client and the architect will expect lower fabrication costs. It is actually common for modular buildings to be more expensive than site-built buildings, with cost savings only noticeable in urban projects where labor costs and the costs for parking equipment are high. Therefore, because time savings can be guaranteed in modular construction, manufacturers stress the fact that “time is money.” For example, with expedited construction an owner of an income-generating business can turn profits sooner. Similarly, a school district will spend less money on student displacement when less time is spent on construction.

Even though modular construction operates on an accelerated timeline and factory workers command lower wages than onsite construction workers, savings will generally be offset by high transportation costs. Design costs will also be higher because the process calls for lengthened design and document development phases. The expectation of consumers that they will be getting a cheaper product thereby limits the potential for design innovation.

Every effort must be made to keep initial costs down. Savings could potentially be accrued through the following measures:

- By quantifying the life cycle value and the re-usability of components, a third-party distributor would be more likely to invest in a leasing business model spanning 20 to 30 years serving multiple users.
- The amount of time needed in design development can be reduced by eliminating the need for duplicate drawing sets. To do so, either the architect would need to bring the construction documents to a level of detail suitable for shop drawing production, or the modular manufacturer would need to handle design decisions.
- Make standard details and specifications available for use by the architect during design development to avoid wasted time spent in re-design when a manufacturer is introduced to the project.
- Value engineering services provided by the modular manufacturer early in design would keep expenses in check, preventing prominent design features from being cut due to budget constraints. This strengthens the argument for a design-build or negotiated bid approach where the modular manufacturer is involved at the beginning of the project.
- While shipping small components increases onsite labor, transportation costs are cheaper. Conversely, shipping larger preassembled components requires less onsite labor but costs more to ship. Creating a balance between cheaper

transportation costs and the difficulty of onsite labor is critical. Connection details for components, ductwork, piping, and electrical systems should be simplified.

- Simplify finishes that need to be applied onsite. Instead of using labor-intensive finish work designed to cover up all mate lines, the design can celebrate the construction.
- Architects should particularly eliminate module seams crossing restrooms to prevent tile work from having to be done onsite, and minimize the number of duct runs and pipes crossing modules.
- By spending time upfront on a coordinated BIM model that can be used to detect problems ahead of time, the number of RFI's (Requests for Information) needed during construction can be reduced.

## 6.2 Opportunities for Future Study

The list of constraints and barriers generated in this study can be used as a tool to inform architects of the potential limits and pitfalls to modular construction. Future explorations into this topic should focus on minimizing the effects of these limitations and on overcoming the pitfalls. Considering the influence of technology in the design world, technological integration into the production line is a medium unexplored to its fullest potential.

The following research questions have been proposed by this study:

**1) Can CAM software be used as a design tool capable of high levels of customization?**

In terms of material processing, CAM software would benefit from being either more design intuitive or built into CAD programs. Points or surfaces along a model can be pinpointed for operations like welding, drilling, or cutting.

**2) With “problem detection” integrated into Revit, can BIM be used as an education tool, preventing code conflicts?**

BIM can be used as an education tool for architects. A 3-dimensional Revit model can be analyzed and dynamically updated with a plugin designed to identify code conflicts. With a program capable of defining dimensional and weight restrictions, module designs can potentially be measured against the regulations of each state and year as they apply.

**3) Can the bill of materials assess the life cycle value of components, quantifying resale value?**

The potential for BIM to be used from securing and processing materials to inspections and the scheduling of component delivery makes it an ideal tool for the industry. Life cycle assessment tools either built-in or linked to material schedules would be used to justify the value of durable construction, or to back long-term leasing strategies with effective cost analyses.

**4) Can augmented reality integrated with BIM be used to supplement shop drawings and facilitate onsite assembly?**

With augmented reality, a real-world environment is viewed through a physical lens that can enhance one's perception. For example, when paired with a 3-dimensional building model, the device would recognize the component under construction and immediately identify the elements missing from the final composition (Webster et al, 2).

**5) How could a plug-and-play program built for rapid prototyping be applied to modular construction?**

“Fritzing” is a tool that simulates the effects of combining different electronic components (breadboards, sensors, cables, etc.). After refining an electronic composition, a prototype of the hardware can be ordered for use (Wettach, Knörig, and Cohen, 3). At the building scale, an architect can develop a library of modular and panelized components, modeled with cost analysis, energy performance data, appliances, and mechanical systems. A program like Fritzing would provide the consumer with the ability to manipulate the building by adding the components of their choosing, and test the building's performance in terms of energy consumption and operational costs before ordering.

**6.3 Summary of Findings**

An architect requires a knowledge both of the general process of modular construction and of the manufacturer's production process to effectively design a modular building. Increased interaction between the designer and the modular construction industry can best

inform architects of what is and isn't possible, and provide manufacturers insight into the interests of the architect.

Size and weight of the modules are restricted by state transportation laws, mode of transportation used, or by the designated path of travel. Damage during transport is possible, but is uncommon.

The structural design of modules, which is engineered in-house by a manufacturer, will affect the breakdown of modules and detailing at mate lines. Without industry-wide standardization, the manufacturer will need to be involved in a collaborated design effort with the architect.

Construction documents are typically inadequate for modular construction. The shop drawings created by the manufacturer are used for acquiring the building permit, fabricating components, performing third-party and internal inspections, and for assembling modules onsite. The development of construction documents and shop drawings must be coordinated to prevent duplication of work.

The effectiveness of a competitive bidding process is dependent on the experience of the architect, whether or not the architect is familiar with modular construction. The level of coordination required generally calls for a design-build approach where the architect, manufacturer, and general contractor have collaborated on previous projects.

Mass customization requires a level of manipulability that CAM-operated machines cannot provide. The software accompanying the machines must be more intuitive to make this possible. Minor changes to the repetitive actions of the machines currently require an intensive re-coding process.

There is an existing stigma of cheap and temporary construction, sometimes associated with modular buildings, that is based on built precedents. In reality, a modular building product is indistinguishable from an onsite-built equivalent.

Clients expect lower costs from modular buildings. Time savings can be expected, but fabrication costs will usually be offset by shipping costs. The industry, therefore, focuses on the construction speed, saving money on employee displacement and allowing the owner to turn profits sooner.

## REFERENCES

- About Modular Construction*. Modular Building Institute [cited 03 February 2012]. Available from [http://www.modular.org/htmlPage.aspx?name=About\\_Modular\\_Construction](http://www.modular.org/htmlPage.aspx?name=About_Modular_Construction).
- Allan, George. 2003. "A Critique of Using Grounded Theory as a Research Method." *Electronic Journal of Business Research Methods* no. 2 (1):1-10.
- Allen, Edward, and Joseph Iano. 2004. *Fundamentals of Building Construction: Materials and Methods*. Hoboken, New Jersey: John Wiley & Sons, Inc.
- Anderson, Mark. 2006. *Prefab Prototypes: Site Specific Design for Offsite Construction*. New York: Princeton Architectural Press.
- Applied Solar Technology, Inc. 2012. *The History of Photovoltaic Cells - Applied Solar Technology*. DIYthemes 2012 [cited April 1 2012]. Available from <http://www.applied-solar.info/solar-energy/history-of-solar-cells/>.
- Arieff, Allison. 2004. "Prefab, Proven." *Dwell* no. 5 (2):123.
- Arieff, Allison, and Bryan Burkhart. 2002. *Prefab*. Layton, Utah: Gibbs Smith, Publisher.
- Barwick, Timi, and Jennifer McGarey. 2001. Annandale Regional Planning Study. In *Report of the Middle School/High School Committee*. Annandale, VA.
- Bell, Eugenia. 2001. *Shigeru Ban*. New York: Princeton Architectural Press.
- Bergdoll, Barry, and Peter Christensen. 2008. *Home Delivery: Fabricating the Modern Dwelling*. New York: The Museum of Modern Art.
- Bernstein, Harvey M., John E. Gudgel, and Donna Laquidara-Carr. 2011. Prefabrication and Modularization: Increasing Productivity in the Construction Industry. In *SmartMarket Report*, edited by McGraw-Hill Construction: National Institute of Standards and Technology.
- Bertelsen, Sven. 2004. "Lean Construction: Where are We and How to Proceed." *Lean Construction Journal* no. 1 (1):46-62.
- Blengini, Gian Andrea. 2009. "Life Cycle of Buildings, Demolition and Recycling Potential: A Case Study in Turin, Italy." *Building and Environment* no. 44 (2):319-330.
- BuildingGreen, Inc. 2012. *GreenSpec Product: EcoVeil PVC-Free Interior Shade Screening 2012* [cited April 1 2012]. Available from <http://www.buildinggreen.com/auth/productDetail.cfm?ProductID=2742>.
- Burns, Carol. 2001. "A Manufactured Housing Studio: Home On the Highway." *Journal of Architectural Education* no. 55 (1):51-57.
- CADeshack. *5DCAD: Space (3D), Time (4D), and Resources (5D)* 2009 [cited 2 September 2011]. Available from <http://www.5dcad.com/>.
- Chiang, Tat-Hung, Bo-Sin Tang, and Francis K. W. Wong. 2008. "Volume Building as a Competitive Strategy." *Construction Management and Economics* no. 26 (2):161-176.
- Clifford, Pearson. 2007. "On a Wooded Site on Taylors Island, Maryland, KieranTimberlake Tested a New Way of Building with the Loblolly House." *Architectural Record* no. 195 (4):146-248.
- Creswell, John W. 2009. *Research Design: Qualitative, Quantitative and Mixed Methods Approaches*. Thousand Oaks, CA: Sage Publishers, Inc.

- Datta, Lois-Ellen. 1990. *Case Study Evaluations*. Washington, DC: U.S. General Accounting Office.
- Deluxe Building Systems, Inc. 2012. *Deluxe Responds Fast in High-Volume Building Systems Production 2009* [cited April 24 2012]. Available from <http://www.deluxebuildingsystems.com/NewsDetail.aspx?nsld=15>.
- Denzin, Norman K., and Yvonna S. Lincoln. 2000. *Handbook of Qualitative Research*. Second Edition ed. Thousand Oaks, CA: Sage Publications, Inc.
- Dini, Massimo. 1984. *Renzo Piano, Projects and Buildings, 1964-1983*. Translated by Richard Sadleir. Milan, Italy: Rizzoli International Publications, Inc.
- DuraSip. 2012. *DuraSip Phenolic Fiberglass Laminante Sheets* [cited April 8 2012]. Available from <http://durasip.com/products.html>.
- Eartheasy.com. 2011. Are LED Fluorescent Tubes Ready for Prime Time. In Eartheasy Blog.
- Energy Solutions Center, FoodPro. 2012. *Air to Air Heat Exchanger 2007* [cited April 1 2012]. Available from [http://www.foodtechinfo.com/FoodPro/Efficiency/air\\_to\\_air\\_heat\\_exchanger.htm](http://www.foodtechinfo.com/FoodPro/Efficiency/air_to_air_heat_exchanger.htm).
- Focus Technology Co., Ltd. 2012. *Phenolic Resin Board - China Board, Resin, Colophony in Other Decoration Materials 2012* [cited April 8 2012]. Available from <http://www.made-in-china.com/showroom/cmbisir/product-detailNbtEROjAEhKS/China-Phenolic-Resin-Board.html>.
- Foundation Supportworks, Inc. 2012. *Corrosion Considerations: Effects of Corrosion on Helical Products 2012* [cited April 1 2012]. Available from <http://commercial.foundationssupportworks.com/resources/corrosion-considerations.html>.
- Fuller, R. Buckminster, and Robert W. Marks. 1973. *The Dymaxion World of Buckminster Fuller*. Doubleday.
- Gann, David M. 1996. "Construction as a Manufacturing Process? Similarities and Differences Between Industrialized Housing and Car Production in Japan." *Construction Management and Economics* no. 14 (5):437-450.
- Gibb, Alistair G. F. 1999. *Offsite Fabrication: Prefabrication, Pre-assembly and Modularization*. Scotland, UK: Whittles Publishing.
- Groat, Linda, and David Wang. 2002. *Architectural Research Methods*. New York: John Wiley and Sons, Inc.
- GSA BIM Guide for Spatial Program Validation Volume 0.96. 2007. In *GSA Building Information Modeling Guide Series*. Washington, DC: General Services Administration.
- Haas, Carl T., James T. O'Connor, Richard L. Tucker, Jason A. Eickmann, and Walter R. Fagerland. 2000. *Prefabrication and Preassembly Trends and Effects on the Construction Workforce*. Austin, Texas: Center for Construction Industry Studies.
- Hartley, Andrew, and Alex Blagden. 2007. *Current Practices and Future Potential in Modern Methods of Construction*. Banbury, UK: Wrap.
- Herbers, Jill. 2004. *Prefab Modern*. New York: Harper Design International.
- Herlitz, Jeff. 2008. "The Eco-Prefab Decade." *Urban Land* no. 67 (5):64-68.
- Home Office Declares Aquaco Grey Water Recycling System a Success!* 2012. 2010 [cited April 1 2012]. Available from [http://www.pollutionsolutions-online.com/news/water-wastewater/17/aquaco/home\\_office\\_declares\\_aquaco\\_grey\\_water\\_recycling\\_system\\_a\\_success/12549/](http://www.pollutionsolutions-online.com/news/water-wastewater/17/aquaco/home_office_declares_aquaco_grey_water_recycling_system_a_success/12549/).

- Home Service Publications, Inc. 2012. *How to Install Cork Tile Flooring: The Family Handyman Magazine* 2012 [cited April 1 2012]. Available from <http://www.familyhandyman.com/DIY-Projects/Flooring/Floor-Installation/how-to-install-cork-tile-flooring>.
- Ibañes-Guzmán, Javier, Peter Atkinson, Brian L. Atkin, Colin E. Bridgewater, and John Bayes. 1990. Automation Systems and Robotic Tools for Modular Building Systems. In *1990 Proceedings of the 7th ISARC*. Bristol, United Kingdom: University of Reading.
- Improving Construction Efficiency and Productivity with Modular Construction. 2010. Charlottesville, VA: The Modular Building Institute.
- Integrated Project Delivery -- A Working Definition: Version 2. 2007. AIA California Council.
- Itard, Laure, and Gerda Klunder. 2007. "Comparing Environmental Impacts of Renovated Housing Stock with New Construction." *Building Research and Environment* no. 35 (3):252-267.
- Jacobs, Karrie. 2007. "The Prefab Decade." *Dwell* no. 9 (3):96-97.
- KieranTimberlake. 2012. *KT [Make It Right] 2007* [cited April 1 2012]. Available from [http://www.kierantimberlake.com/pl\\_sustainability/make\\_it\\_right\\_1.html](http://www.kierantimberlake.com/pl_sustainability/make_it_right_1.html).
- Kieren, Stephen, and James Timberlake. 2004. *Refabricating Architecture: How Manufacturing Methodologies are Poised to Transform Building Construction*. New York: McGraw Hill.
- Kobet, Robert J. 2009. Modular Building and the USGBC's LEED™ Version 3.0 2009 Building Rating System. The Modular Building Institute.
- Koch, Carl. 1958. *At Home with Tommorrow*. Toronto, Canada: Clarke, Irwin and Company, Ltd.
- Lechner, Norbert. 2009. *Heating, Cooling, Lighting: Design Methods for Architects*. Hoboken, NJ: John Wiley & Sons.
- LiteSteel Technologies America, LLC. 2012. *LiteSteelbeam* 2008 [cited April 1 2012]. Available from <http://www.litesteelbeam.com/>.
- Lot-EK. 2012. *MDU (Mobile Dwelling Unit) - Lot-EK Architecture* [cited April 1 2012]. Available from <http://www.lot-ek.com/MDU-Mobile-Dwelling-Unit>.
- Lu, Na. 2007. *Investigation of the Designers' and General Contractors' Perceptions of Offsite Construction Techniques in the United States Construction Industry*, Department of Career and Technology Education, Clemson University, Clemson, GA.
- Magnum Building Products, Inc. 2012. *Magnum Building Products* [cited April 8 2012]. Available from <http://www.magnumbp.com/products/mb-gallery.html>.
- Martinez, Santiago, Alberto Jardon, Jose Maria Navarro, and Patricia Gonzalez. 2008. "Building Industrialization: Robotized Assembly of Modular Products." *Assembly Automation* no. 28 (2):134-142.
- McQuaid, Matilda. 2003. *Shigeru Ban*. New York: Phaidon Press, Inc.
- MKThink. 2004. *Modular Learning Environments: Beyond the 'Classroom in a Can'*.
- Monolite UK, Ltd. *D-Shape* 2011 [cited 31 March 2011]. Available from <http://www.d-shape.com/cose.htm>.
- Morse-Fortier, Leonard J. 1994. "From Frank Lloyd Wright's Usonian Automatic Building System: Lessons and Limitations in a Lost Paradigm." *Journal of Architecture and Planning Research* no. 11 (4):274-293.



- Neelamkavil, Joseph. 2009. Automation in the Prefab and Modular Construction Industry. In *International Symposium on Automation and Robotics in Construction ISARC 2009*. Austin, TX: NRC Institute for Research in Construction.
- OEA. 2012. OEA. DM Web Solutions Ltd. [cited April 1 2012]. Available from [http://www.oea.org.uk/view\\_portfolio.php?view=57](http://www.oea.org.uk/view_portfolio.php?view=57).
- Oversized Load, Permit and Pilot Car Requirements*. ParkerPilot Pilot Cars 2011 [cited 24 February 2012. Available from <http://parkerpilot.com/regmap.html>.
- Permanent Modular Construction 2011: Annual Report. 2011. The Modular Building Institute.
- Piller, Frank T. 2006. Mass Customization and Open Innovation News. *Frank Piller's Web Site on Mass Customization*, Customer Co-Creation & Open Innovation 9 (2): 20.
- Reidelbach, J. A. 1971. *Modular Housing - 1971; Facts and Concepts*. Boston: Cahner Books.
- Relocatable Buildings: 2011 Annual Report. 2011. The Modular Building Institute.
- "Robot-Crafted Housing for Post Disaster Areas." 2006. *Urban Land* no. 65 (5):20.
- Safdie, Mosche. 1970. *Beyond Habitat*. Edited by John Kettle. Montreal, Quebec: Tundra Books of Montreal.
- Small Houses of the Twenties: The Sears, Roebuck 1926 House Catalog, An Unabridged Reprint*. 1991. New York: Dover Publications, Inc.
- Smith, Elizabeth A.T. 2007. *Case Study Houses: 1945-1966: The California Impetus*. Hong Kong: TASCHEN GmbH.
- Solar Thermal Heating*. 2012. [cited April 1 2012]. Available from <http://www.solarthermalmagazine.com/SolarThermal/solar-thermal-heating/>.
- Sylvester, Michael. *FabPrefab: Modernist Prefab Dwellings*. Sandor Pty, Lt. 2004 [cited 21 January 2011. Available from [www.fabprefab.com](http://www.fabprefab.com).
- Tam, Vivian W. Y., C. M. Tam, S. X. Zang, and William C. Y. Ng. 2007. "Towards Adoption of Prefabrication in Construction." *Building and Environment* no. 42 (10):3642-3654.
- Webster, Anthony, Steven Feiner, Blair McacIntyre, William Massie, and Theodore Krueger. *Augmented Reality in Architectural Construction, Inspection, and Renovation*. Columbia University.
- Wettach, Reto, André Knörig, and Jonathan Cohen. *Fritzing: Open-source Software for Documenting Prototypes, Learning Interactive Electronics, and PCB Production*. In [www.fritzing.org](http://www.fritzing.org), edited by Postdam University of Applied Sciences. Brandenburg, Germany.
- Yin, Robert K. 1984. *Case Study Research: Design and Methods*. Beverly Hills, CA: SAGE Publications, Inc.

## **APPENDIX A: PROJECT DRAWINGS**

The design of the case study project is credited to students who, at the direction of Professor Yvan Beliveau, participated in a semester-long course in the Spring of 2011. The development of the project (a system of sustainable, temporary, re-usable, and affordable classrooms) was conducted in three phases. First, the program was introduced with a design charette conducted at Virginia Tech's School of Building Construction. The charette teamed industry professionals with students in order to develop broad ideas on modularity, construction, portability, sustainable building systems integration, and classroom layouts. These topics were studied in depth throughout the semester while students collaborated on a single classroom prototype that could be adaptable to varying sites, programs, and scales. The final design was presented to a local school district to test its feasibility. Having participating in both the charette and in the course, I continued developing the drawings in order to bring the project to an adequate level of detail for its use in this case study.

The final drawings set produced is enclosed in this Appendix. The students and industry partners who participated are listed below:

### **Virginia Tech Participants:**

*Faculty:* Yvan Beliveau, George Richard

*PHD Students:* Joseph Tomi, Vera Novak, Brendan Johnston, Ana Jaramillo

*Masters Students:* Kamille Ditcher, Adrian Carter, Alex Amrine, Milton Salcedo, Josh Lilly, Josh Echols, Mike Roberts

*Bachelors Students:* Josh Frady, Samantha Hugo

### **Industry Partners:**

*Turner Construction:* Susan Boggs, Pamela Johnson, Joe Swanson, Tom Engers

*Fanning Howey Associates, Inc.:* Ed Schmidt, Bruce Hobby, Eric McMillan, Julia Devine, Rocio Sanchez Seijas



*Figure A.1* two-classroom rendering

### Program

A relocatable education facility implemented at three different scales:

- 1) A single classroom accommodating 20 to 25 students with independent power and mechanical systems
- 2) Three connected classrooms with enclosed communal spaces, and independent power and mechanical systems
- 3) 20 connected classrooms with necessary support facilities

Ultimately, the aim is to create a facility capable of supporting creative thinking and mental growth, demonstrating innovation in its design.

### Design Intent

The manufacturing process envisioned is separated into two primary activities: the fabrication of a base structural system constant in all applications, and the fabrication of an array of auxiliary features that are available for inclusion based on the needs of the individual client. The base structural system (columns, floor and roof components), using highway transportation size requirements for the controlling dimensions, acts as the canvas for resource components to be plugged in wherever they are deemed necessary.

Because the building's structure and its resources are segregated, the structure can stand independently, thereby making it possible for its resources to be replaced, upgraded and

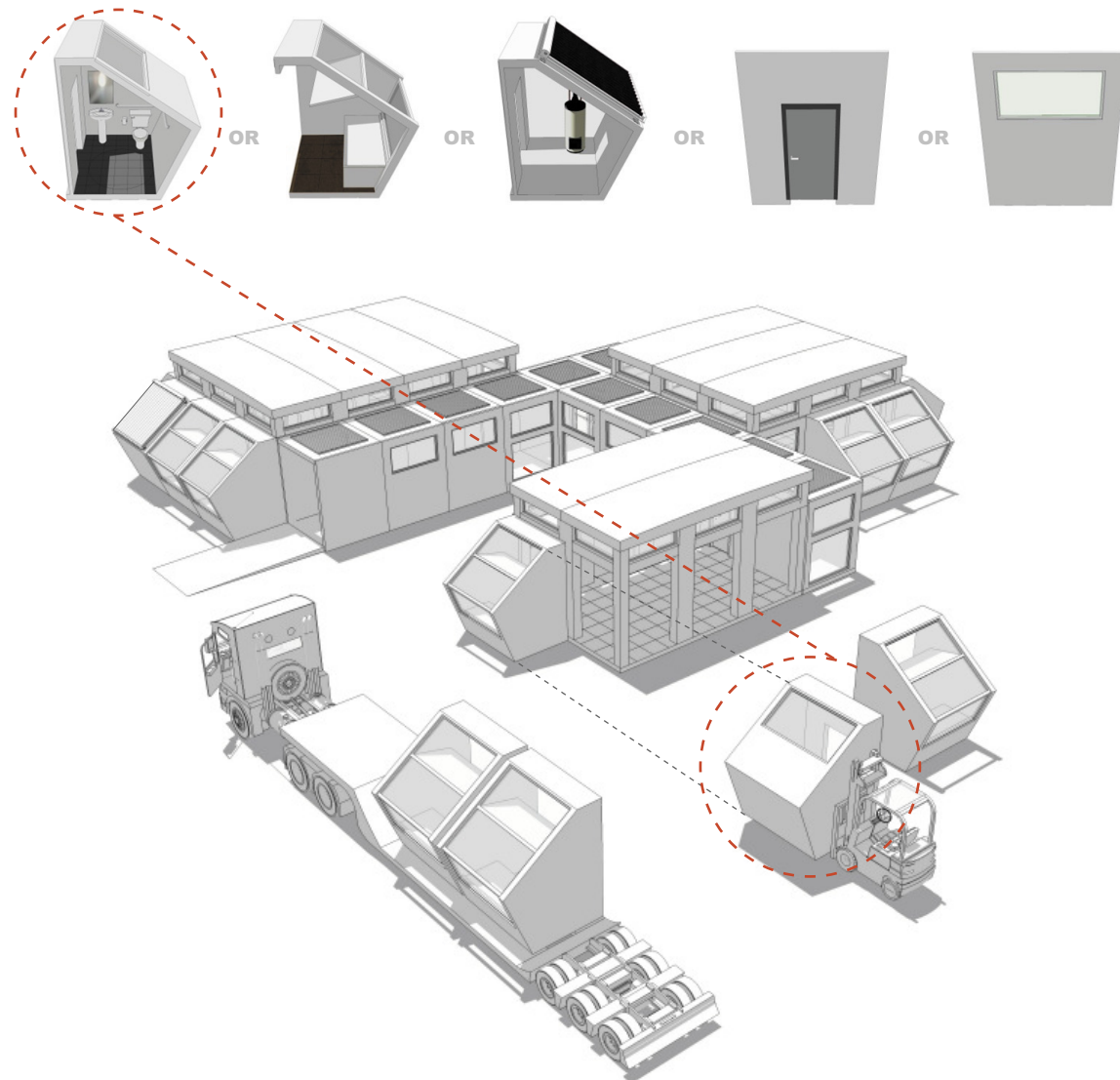


Figure A.2 building diagram

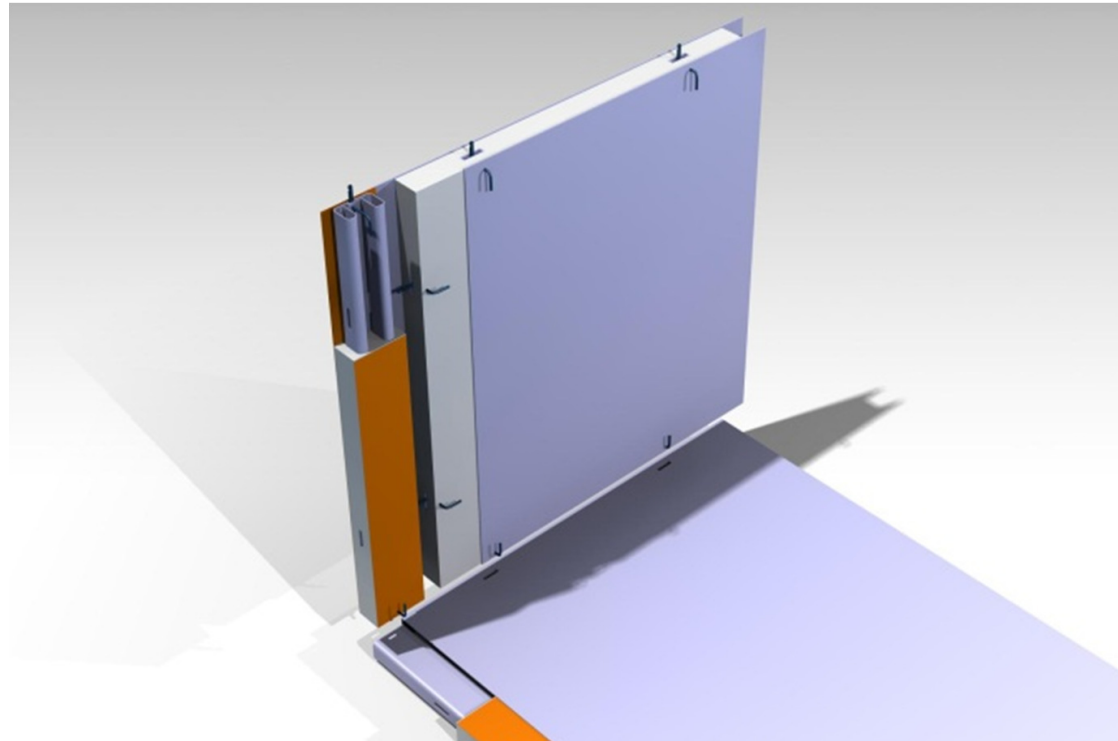
reinvented over time without full demolition and renovation.

These resource components include both modular structures (pods) that are handled with a forklift, and panelized structures that can be handled by a manned crew. The overall flexibility of the system is dependent on the library of components available, which over time can be substantial.

### Panelized Structures (SIPs)

The structural skeleton of the building will utilize an assembly of structurally insulated panels (SIPs) for wall panels, roof and floor systems. All panels will be set on an 8' controlling dimension module (8' x 24' floor/roof, 8' x 10' wall panels, and 8' x 2'-6" clerestory panels). The composition of the SIPs include the following:

- 1) 1/8" magnesium board applied as an interior finish where desired (replacing gypsum board) creating a durable and non-combustible surface
- 2) 1/16" phenolic resin sandwich layers applied for weather proofing, smoke proofing and exterior finish customization (by color)
- 3) 6" rigid soy-based foam insulation with lap joint ends providing a continuous R-24 (foamed-in-place fabrication process enables the cam locks, window fabrications, and threaded rods for attachment points to all be embedded into the panels)



*Figure A.3 SIP panel design with embedded cam locks (drawing by Brendan Johnston)*



*Figure A.4 cam lock mechanism*



*Figure A.5 light, cold-formed steel structure (Lite Steel Technologies America 2008)*



*Figure A.6 phenolic resin skin (DuraSip)*

4) Integrated cam lock system provides a simple weather-tight joint that permits component demountability

**Modular Structures (pods)**

Components maintain a common footprint (8' x 8' x 10', w/ 6' floor area), yet are customized to accommodate varying functions. Serving both auxiliary teaching functions and utility functions that are considered necessary for a self-sustaining external classroom, the library of available components is expected to grow as both programmatic needs change and technology changes.

The material composition of the pods is the same SIP assembly as the flat panels, yet the forms are customized to a higher degree in order to achieve component variation. The SIP's span between a cold-formed steel truss that can be bolted to the steel columns, providing a seamless transition between the volumetric pods and flat panels.

**Sustainable Building Systems**

Because there is an emphasis on sustainable design in new educational buildings, the application of sustainable building systems was explored wherever possible.



Figure A.7 pod variation design (drawing set by Josh Lilly)

### Helical Pile Foundation

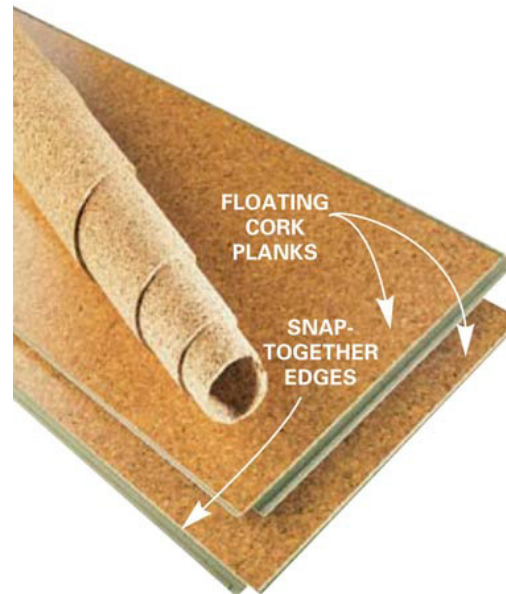
Providing that the appropriate soil composition can be found at the building site, helical piles fulfill the need for a demountable foundation on a temporary site, minimizing site disturbance. If the soil composition is not adequate for helical piles, a permanent foundation must be installed. (\$812 per pile)



*Figure A.8* helical pile (Foundation Supportworks 2012)

### Cork Floating Floor System

As a flooring option, cork can provide a durable yet resilient alternative suitable for educational facilities. Cork is a naturally renewable resource which is harvested every 9 or 10 years from tree bark. It is used in the project as a soft surface for improved acoustical performance. The cork's honeycomb like cellular structure significantly reduces noise and vibrations. The snap-in-place floating floor option eliminates the need for the adhesion to the floor subsurface, easing the replacement of damaged tiles. (\$5 per tile or per sq.ft.)



*Figure A.9* cork floor tiles (Home Service Publications 2012)

### Grey Water Recycling

Adequate collection and storage systems make the water collected from roof runoff usable for restroom and outdoor irrigation applications. While a potable water supply is required for sinks and showers, the building's contribution to the local waste stream can be eliminated through the recycling and filtration of grey water, and through the use of incinerating toilets to dispose of black water. Incinerating toilets are fueled by propane, natural gas, or diesel, and operate on a low flush system using 0.3-0.5 gallons of water. (\$2190 for a 66 gallon tank, sand filter, and pump)



*Figure A.10* grey water purification system (Aquaco Grey Water Recycling System 2010)

### Solar Thermal Water Heating

The use of a solar thermal array can take advantage of solar gains for hot water requirements (restroom sink and shower applications). The heated liquid in the panels is pumped to a hot water tank, where heat is transferred to the domestic water supply. 90 degree exposure to the sun is optimal (with a 30 degree tolerance), so an adjustable platform would make solar thermal incorporation feasible for integration on a building without a known site. (\$1300 for a 3' x 7' panel)



Figure A.11 solar thermal panel (Solar Thermal Heating)

### Solar Power

Solar power is designed as an optional feature supplementing both a standard grid connected system and an efficient daylighting strategy. Because electricity must be supplied to an educational facility at all times of the day, a substantial photovoltaic array and battery bank would be required for a stand alone system. Instead, energy collected is inverted into usable electricity that can be immediately sold back to the local utility grid. Electricity expenses are thereby reduced (or offset) by the income generated from the photovoltaic array. Furthermore, because they are built on a demountable pod structure, the implementation of solar power can be postponed until funds are available. (\$310 per 5' x 2' panel, \$1500 for an inverter, and up to \$250 for mounting hardware)



Figure A.12 photovoltaic array (Applied Solar Technology 2012)

### Air-to-air Heat Exchange System

An enthalpy wheel built into the heat exchanger saves both cooling and reheating energy through the transfer of heat directly from the entering air to the low-temperature air leaving the cooling coil. It can be used to precool or preheat incoming outdoor air with exhaust air from the conditioned spaces. With the system, a high heat transfer effectiveness can be achieved with a smaller HVAC unit. So, instead of using one large centralized unit, smaller HVAC units designed for one, two, or three classrooms combined decreases the length of duct runs, and adds another level of control to the monitoring of indoor air temperature. (\$1959 per unit)

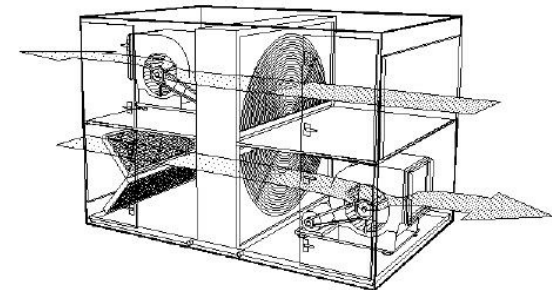


Figure A.13 heat exchanger with enthalpy wheel (BuildingGreen 2012)



### Light Emitting Diodes (LED's)

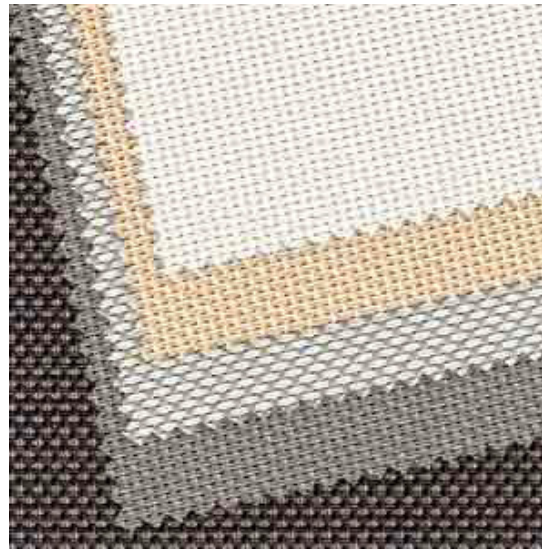
Educational facilities require the continuous operation of emergency lighting. An installation of LED lighting can function continuously for 11 years without replacement. Over 85 percent of the electrical energy consumed is converted into light energy, with only 15 percent lost as heat. With an internally load dominated building, any reduction in year round cooling load is beneficial. (\$575 per 4' strip fixture with 2 bulbs included; \$50 per spot light fixture with bulb included)



**Figure A.14** LED light tubes (Energy Solutions Center 2007)

### Interior Shading Devices

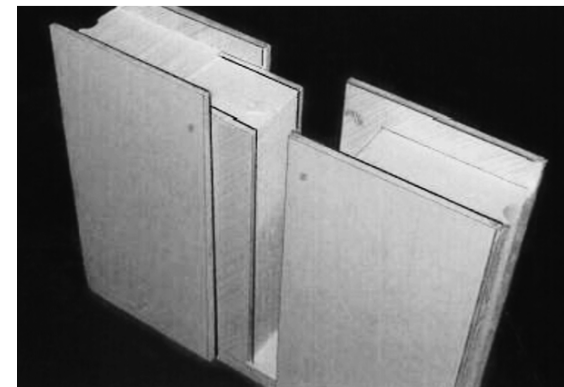
Manually operated shading devices give teachers control over views, glare, and the amount of daylight coming through the clerestory and panel windows. Because the clerestory runs along the full perimeter of the building, having control throughout the day and seasons can also accommodate the use of overhead projectors. (\$375 per shade)



**Figure A.15** adjustable interior shades (Eartheasy.com 2011)

### Structurally Insulated Panels (SIP's)

Using structurally insulated panels instead of a studded wall system provides uniform insulating throughout the construction without an excessively thick wall assembly. Each panel consists of a 6" cast soy-based foam insulation (with a continuous R-24) sandwiched between two 1/16" phenolic resin skin surfaces (which are suitable for use as both indoor and outdoor surfaces). With proper gasketing, the use of the phenolic resin skin on roof surfaces eliminates the need for an additional rolled waterproofing membrane. The panels are manipulated for different needs in their application as walls, roofing or flooring. (\$45 per sq. ft.)



**Figure A.16** soy-based foam insulation SIP's

### Phenolic Resin Skin

Instead of SIP's being sandwiched between OSB (oriented strandboard) plywood sheets, a weather-proof phenolic resin skin is used, providing a customizable surface. The material is mold-resistant, insect and chemical-proof, non-combustible (the material chars rather than burns), impact resistant, environmentally friendly, and lightweight. The composite strength of the sheets added to the SIP's eliminate the need for structural support (minor beams) for spanning between major girders. Using the finish on both the interior and exterior surface of the SIP's can remove as much labor-intensive finish work required onsite as possible, reducing costs.



**Figure A.17** phenolic resin sheets customizable in color and surface texture (Focus Technology Co. 2012)

### Magnesium Oxide Wallboard

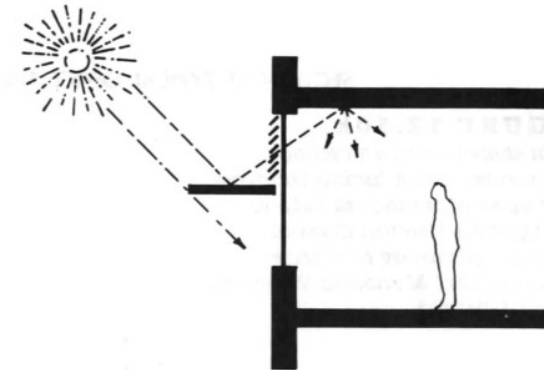
Magnesium wallboard serves the fire resistance and sound control function on the interior finish of the building in place of gypsum drywall. The product is more expensive than typical drywall sheets, but it is mold and water-proof (can absorb water, but its performance is unaffected), and is durable, making it less susceptible to damage during transport in stacked form. The wallboard is used wherever desired in the classroom design, and can be used strategically for improved acoustic performance. (\$32 per 4'x8' sheet)



**Figure A.18** Magnum Board building product used in place of gyp board (Magnum Building Products 2012)

### Light Shelves

Light shelf pods are used where possible to allow daylight to penetrate deep into the classroom space while minimizing glare and solar gains during the warm months. Passive solar gains on the south facing façade can be used to reduce the heating load of the building, and can similarly reduce the amount of active electric lighting operating during school days.

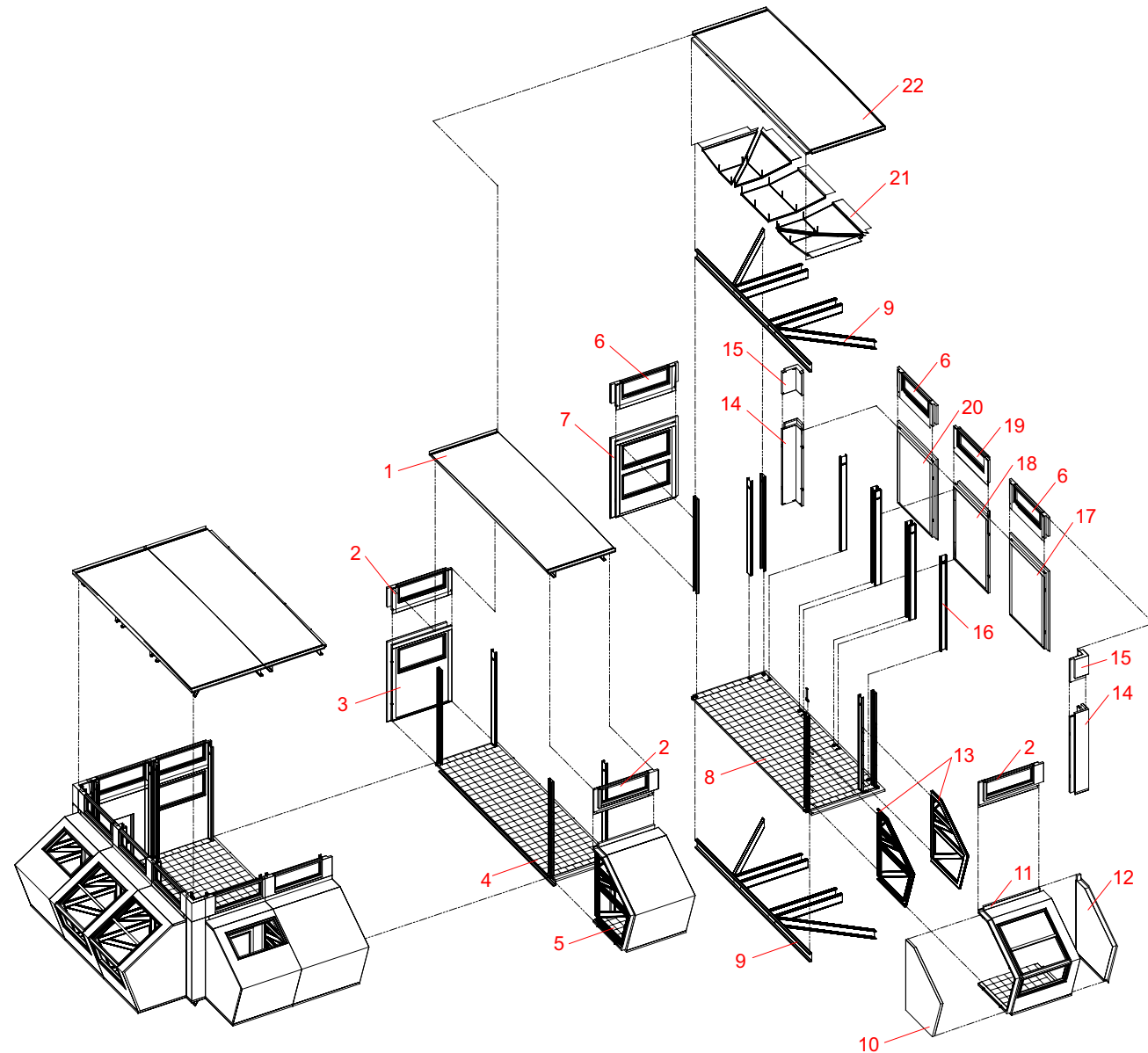


**Figure A.19** light shelf design (Lechner 2009, 323)



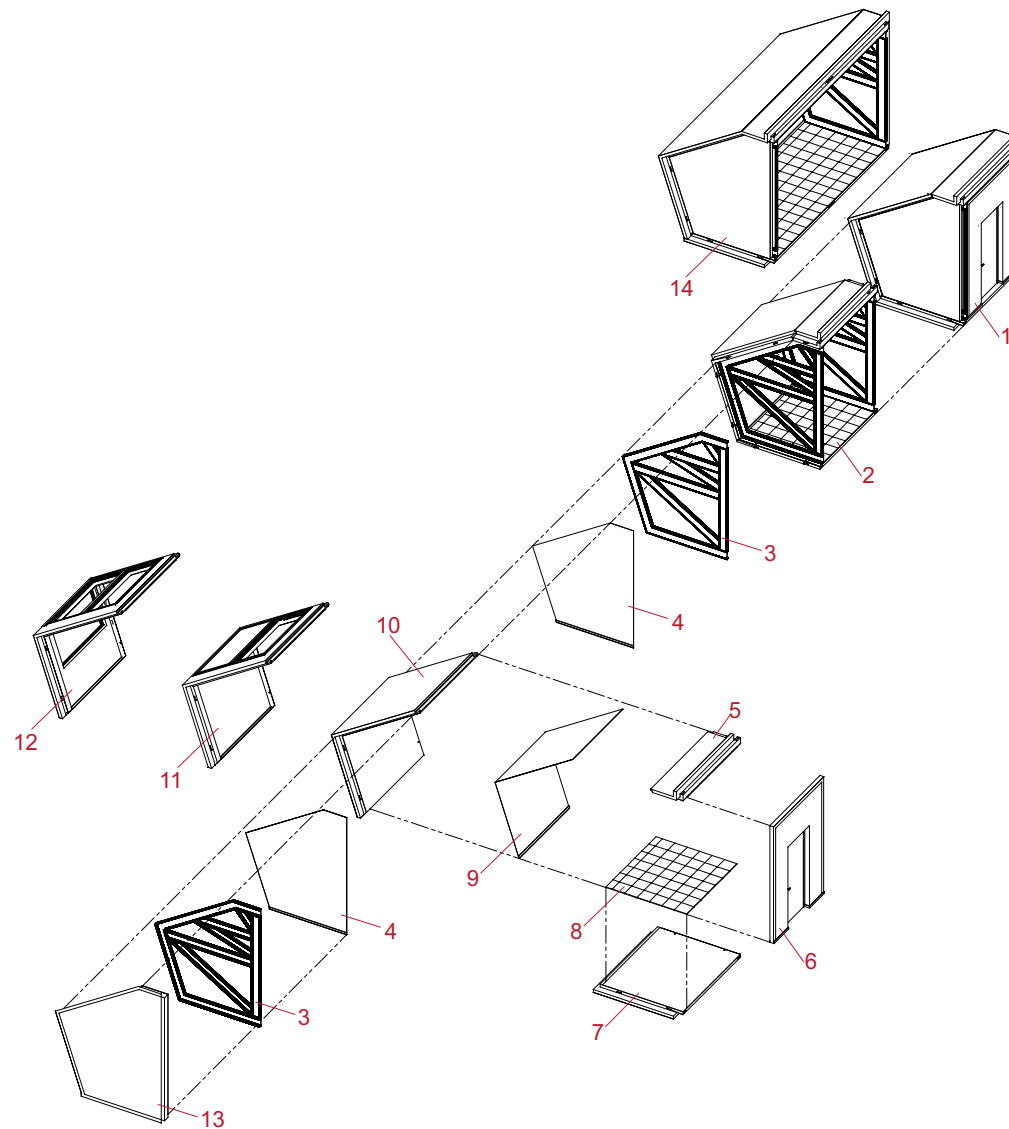
*Figure A.20 interior rendering*

- 1 roof component (m/f)
- 2 clerestory component (m/f)
- 3 single window wall component (m/f)
- 4 floor component (m/f)
- 5 pod component (m/f)
- 6 clerestory component (m)
- 7 double window wall panel component (m)
- 8 corner floor component (m/f)
- 9 corner floor/roof structure
- 10 pod interior wall partition
- 11 pod SIP's (m/f)
- 12 pod exterior wall SIP (f)
- 13 pod structure
- 14 corner wall component (f)
- 15 corner clerestory component (f)
- 16 steel column and angle brackets
- 17 wall component (m)
- 18 wall component (f)
- 19 clerestory component (f)
- 20 wall component (m/f)
- 21 corner roof acoustic tiles
- 22 corner roof SIP (m/f)



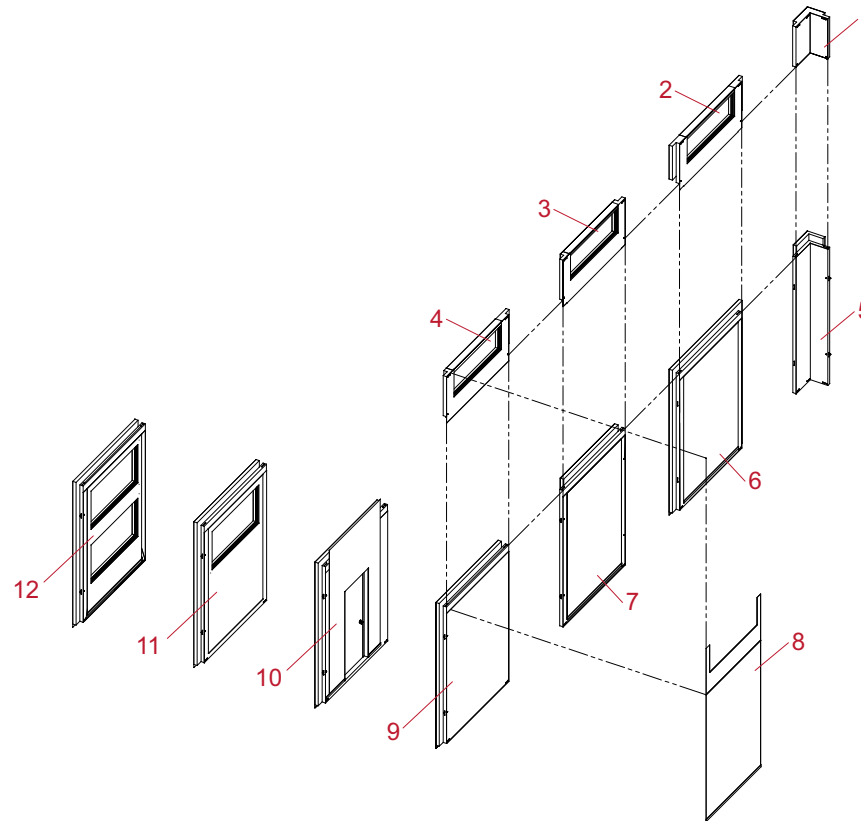
*Figure A.21 exploded axonometric*

- 1 complete pod component w/ male lap-joint ends, interior partition wall, and interior door partition
- 2 base pod component w/ female lap-joint ends
- 3 pod structure (Lite Steel Beams: 800LSB250-59)
- 4 interior partition wall (for pod-to-pod separation)
- 5 pod roof SIP w/ male/female lap-joint ends
- 6 interior partition wall w/ door assembly (for privacy)
- 7 pod floor SIP w/ male/female lap-joint ends
- 8 floating cork floor (1' x 1' interlocking planks)
- 9 magnesium wall board and cork base for finish surface
- 10 pod wall (adhered SIP's) w/ male/female lap-joint ends
- 11 alternative pod wall option w/ one double-paned window assembly
- 12 alternative pod wall option w/ three double-paned windows assemblies
- 13 exterior pod SIP (for end pods)
- 14 double pod option



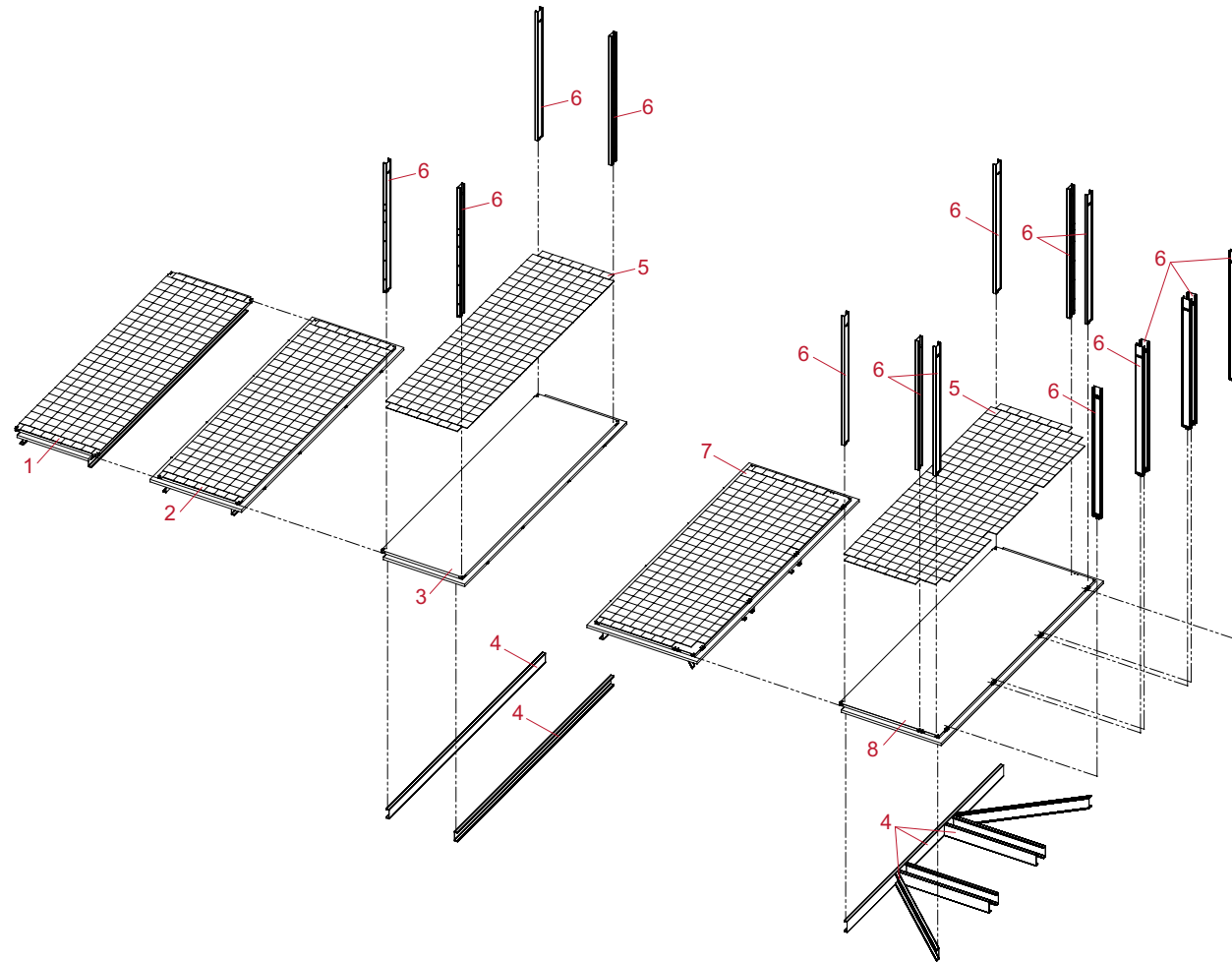
**Figure A.22** pod component assembly

- 1 corner clerestory component (comprised of adhered SIP's) w/ female lap-joint ends
- 2 clerestory component w/ double-paned window assembly and male lap-joint ends
- 3 clerestory component w/ female lap-joint ends
- 4 clerestory component w/ male/female lap-joint ends
- 5 corner component (comprised of adhered SIP's) w/ female lap-joint ends
- 6 wall component w/ male lap-joint ends
- 7 wall component w/ female lap-joint ends
- 8 magnesium board and base finish surfaces
- 9 wall component w/ male/female lap-joint ends
- 10 alternative wall component option w/ exterior door assembly
- 11 alternative wall component option w/ one double-paned window assembly
- 12 alternative wall component option with two double-paned window assemblies



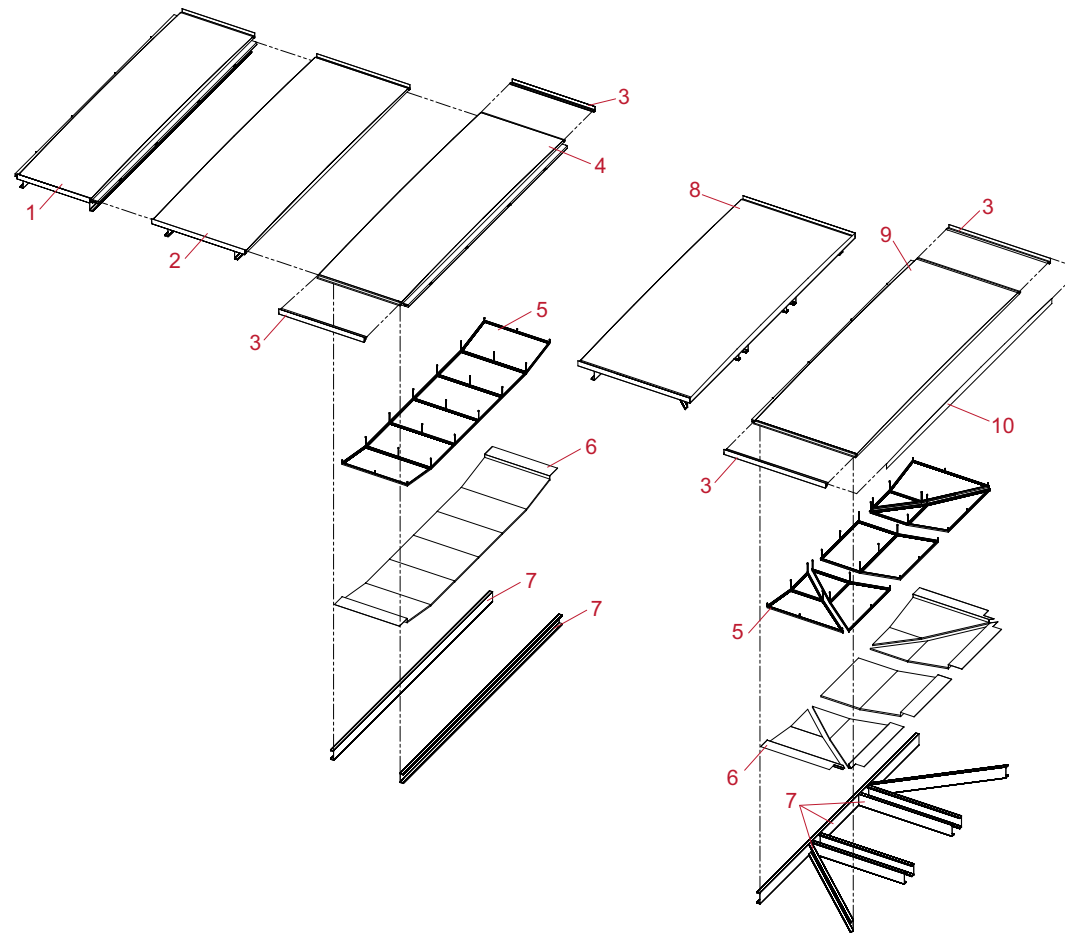
**Figure A.23** wall panel and clerestory component assembly

- 1 floor component (comprising of cork floating floor, SIP and steel beams) w/ male lap-joint ends
- 2 floor component w/ female lap-joint ends
- 3 floor SIP w/ male/female lap-joint ends
- 4 structural beam (Lite Steel Beam: 1200LSB250-118)
- 5 cork floating floor (1' x 1' interlocking planks)
- 6 column structure w/ bracket connections (Lite Steel Beam: 800LSB250-79)
- 7 corner floor component (comprising of cork floating floor, SIP and beams) w/ female lap-joint ends
- 8 corner floor SIP w/ male/female lap-joint ends



**Figure A.24** floor component assembly

- 1 roof component (comprising of SIP, integrated aluminum gutter, steel beams, and dropped acoustic ceiling grid) w/ male lap-joint ends
- 2 roof component w/ female lap-joint ends
- 3 bent aluminum gutter system embedded in the ends of the SIP's
- 4 roof sip w/ male/female ends
- 5 bent aluminum ceiling grid and hangers
- 6 acoustic tiles 4' x 7' sheets (max)
- 7 structural beam (Lite Steel Beam: 1200LSB350-134)
- 8 roof corner component (comprising of corner SIP, integrated aluminum gutter and fascia plate, steel beams, and dropped acoustic ceiling grid) w/ male lap-joint ends
- 9 corner roof SIP w/ male/female ends
- 10 aluminum fascia plate

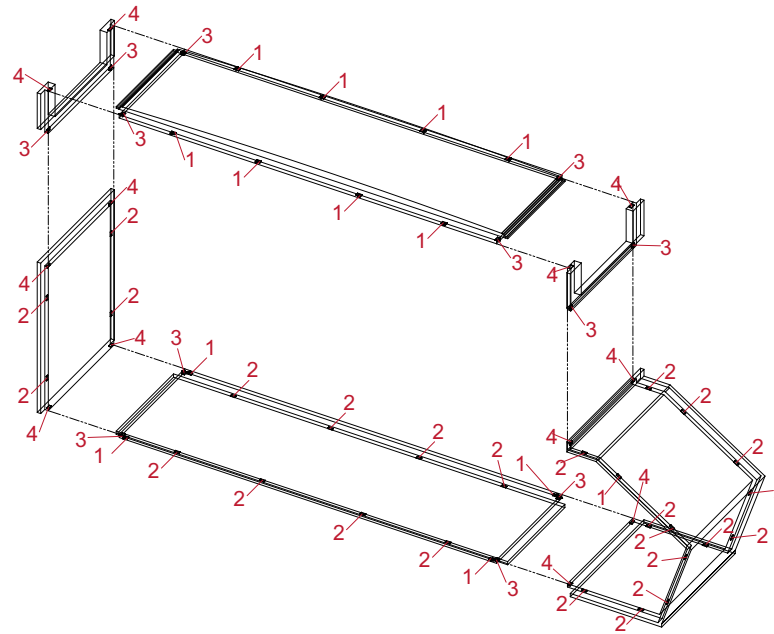


**Figure A.25** roof component assembly



**Typical male-end lap joint components:**

- 1 locking point (on male lap-joint ends only)
- 2 strike (on male lap-joint ends only)
- 3 locking point (on all components)
- 4 strike (on all components)



*Figure A.26 location of cam lock mechanisms*

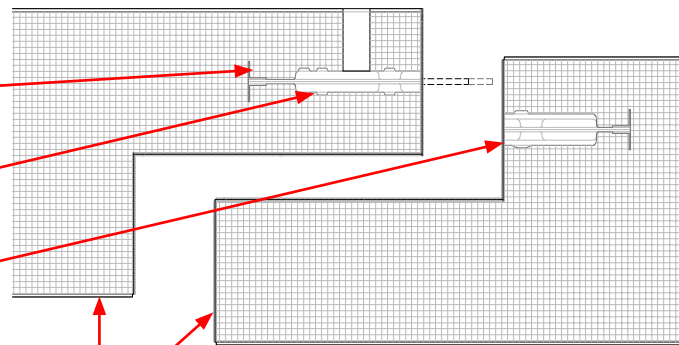
**Typical lap joint detail:**

cam locks are embedded within rigid foam insulation and have a 1/2" tolerance

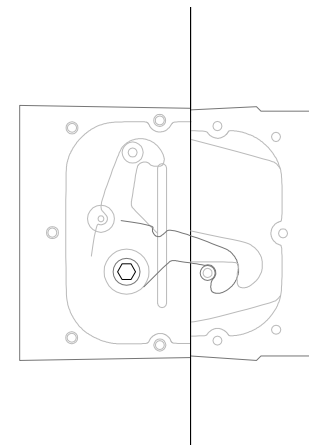
locking point (access with hex-wrench)

strike

6" lap joint w/ 1/16" resilient gasketing applied to joint surfaces (typical)



*Figure A.27 detail section*



*Figure A.28 detail plan*

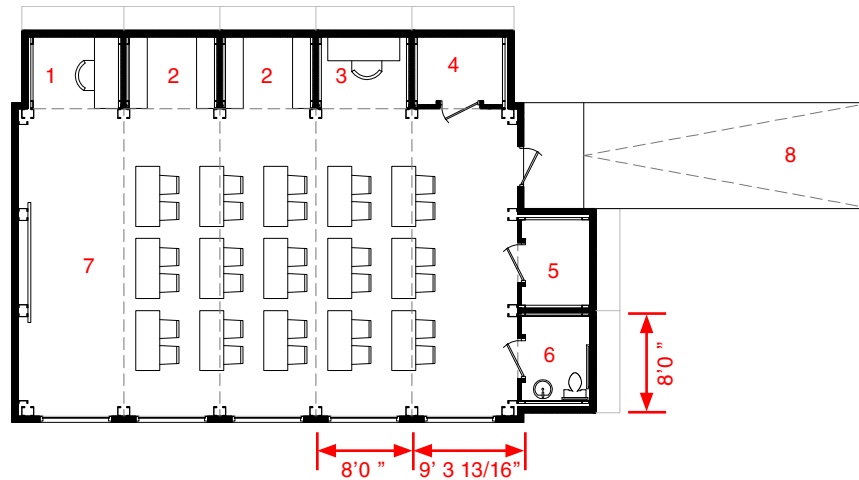


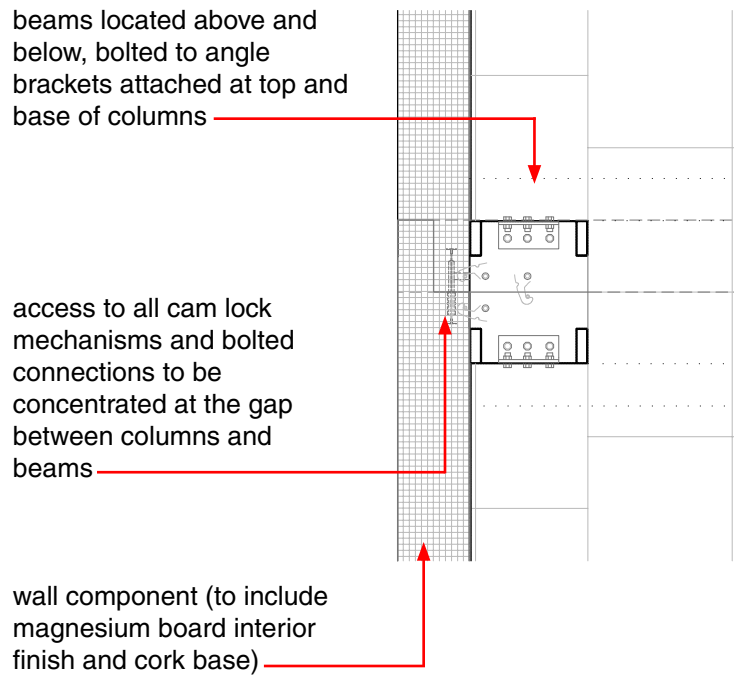
**Figure A.29 (top)**  
photomontage

**Figure A.30 (bottom)**  
fit-out plan

**Single classroom plan:**

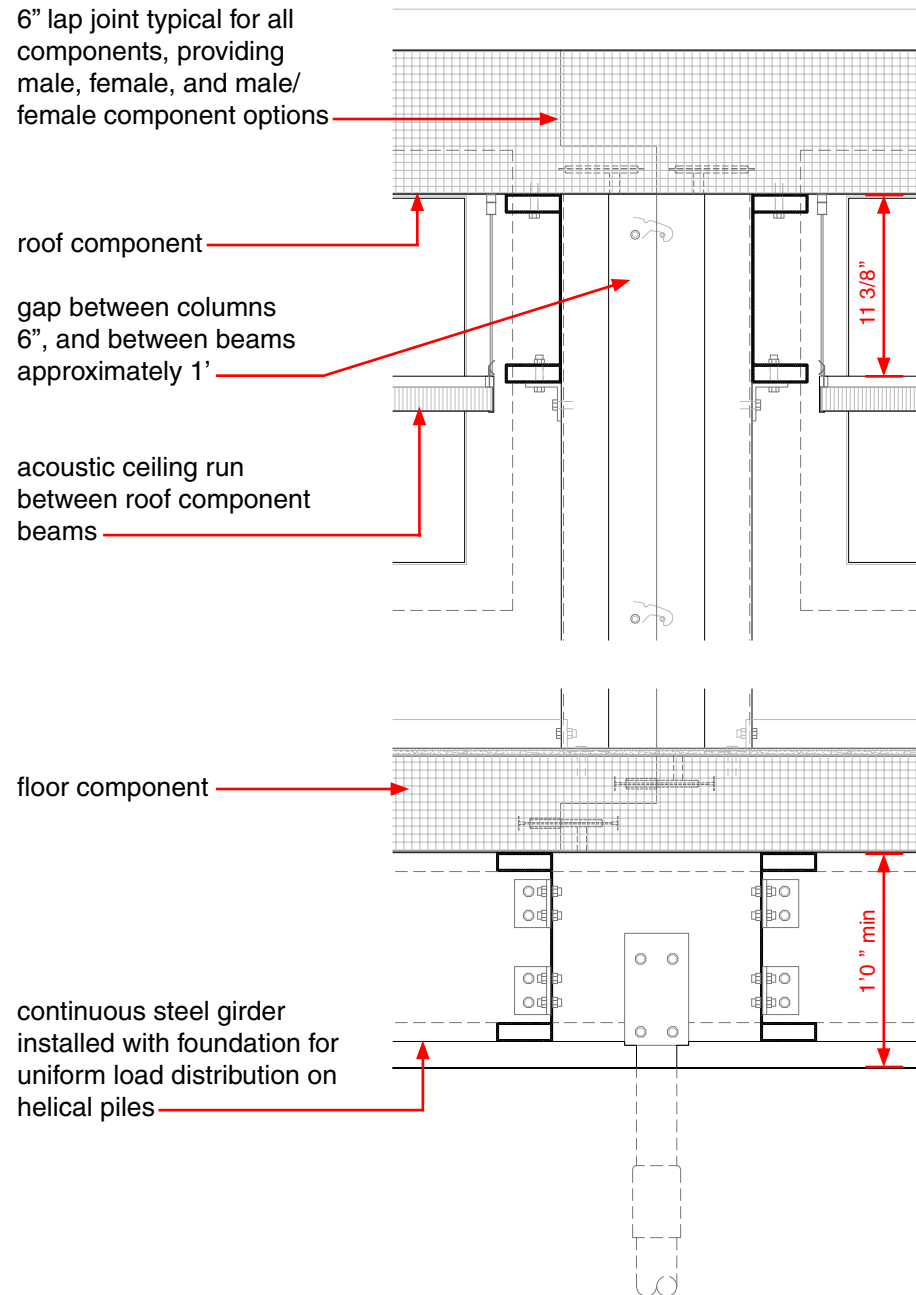
- 1 teacher resource pod
- 2 greenhouse pod
- 3 study center pod
- 4 storage pod
- 5 mechanical room pod
- 6 restroom pod (meeting ADA regulations)
- 7 plan accommodating 24 students
- 8 ramp provided at a slope of 1:20 (no handrail required)

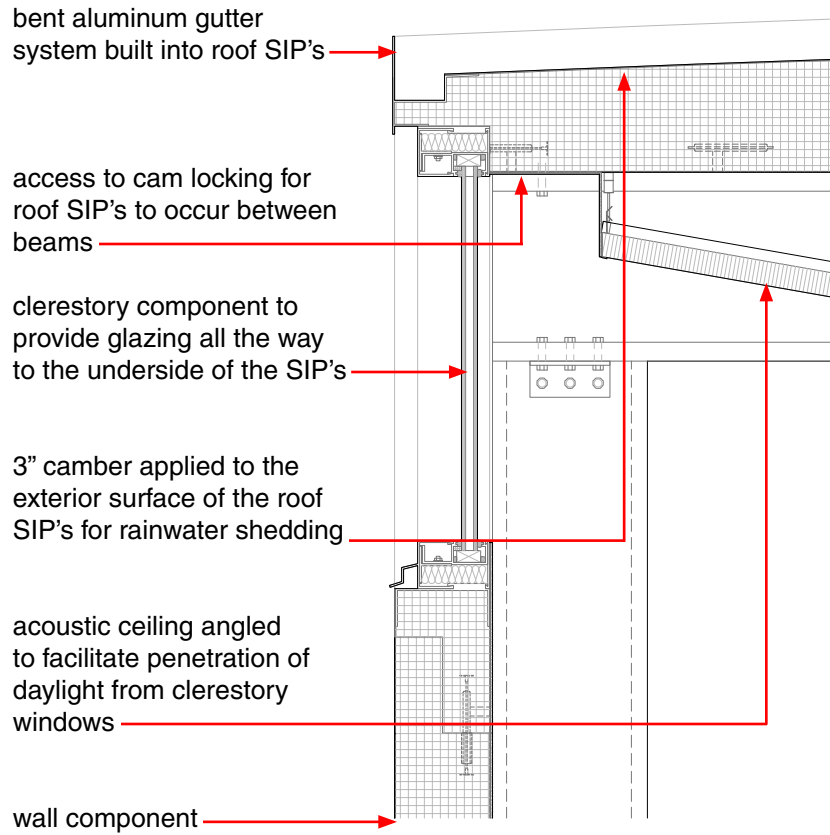




**Figure A.31** (left)  
detail plan at floor/wall  
component connection

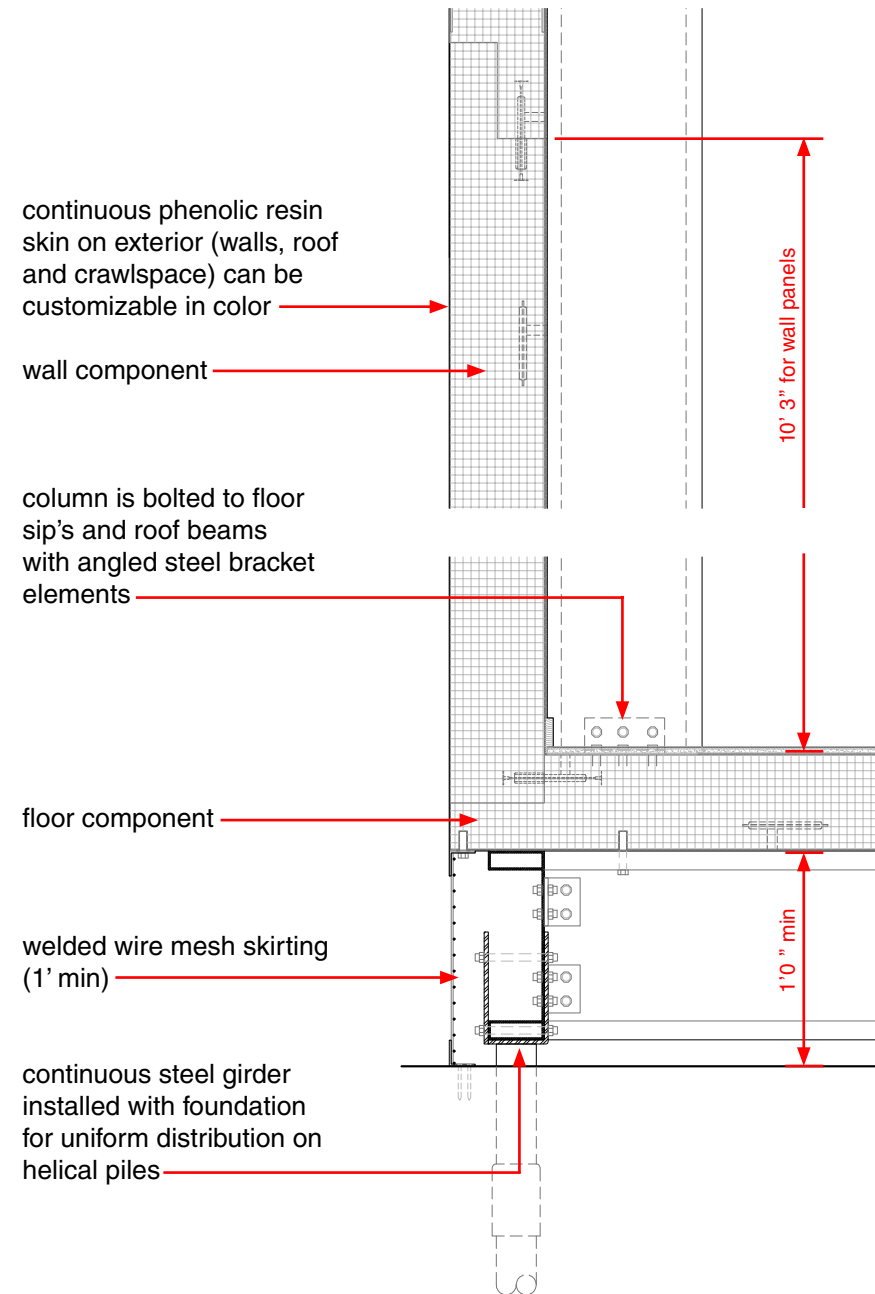
**Figure A.32** (right)  
typical section through  
beams





**Figure A.33** (left) typical clerestory detail

**Figure A.34** (right) typical wall component detail



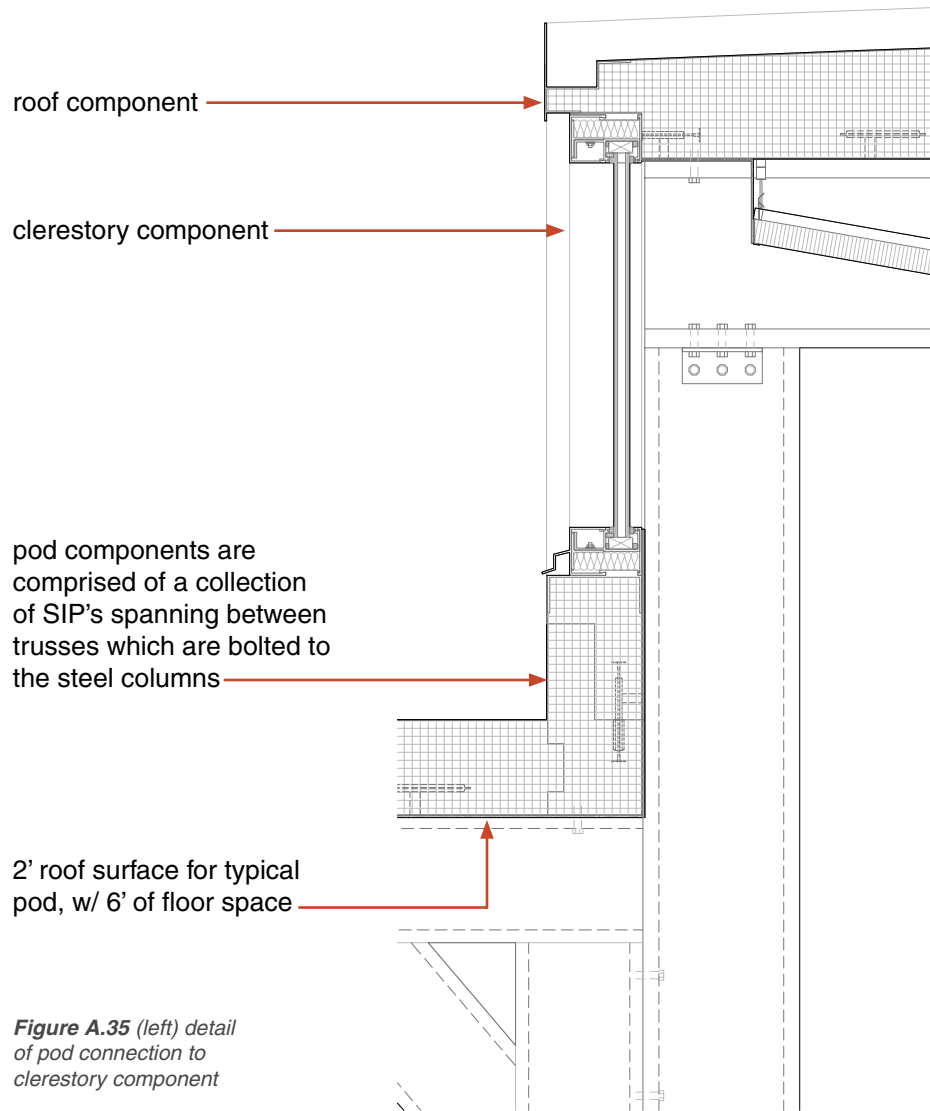


Figure A.35 (left) detail of pod connection to clerestory component

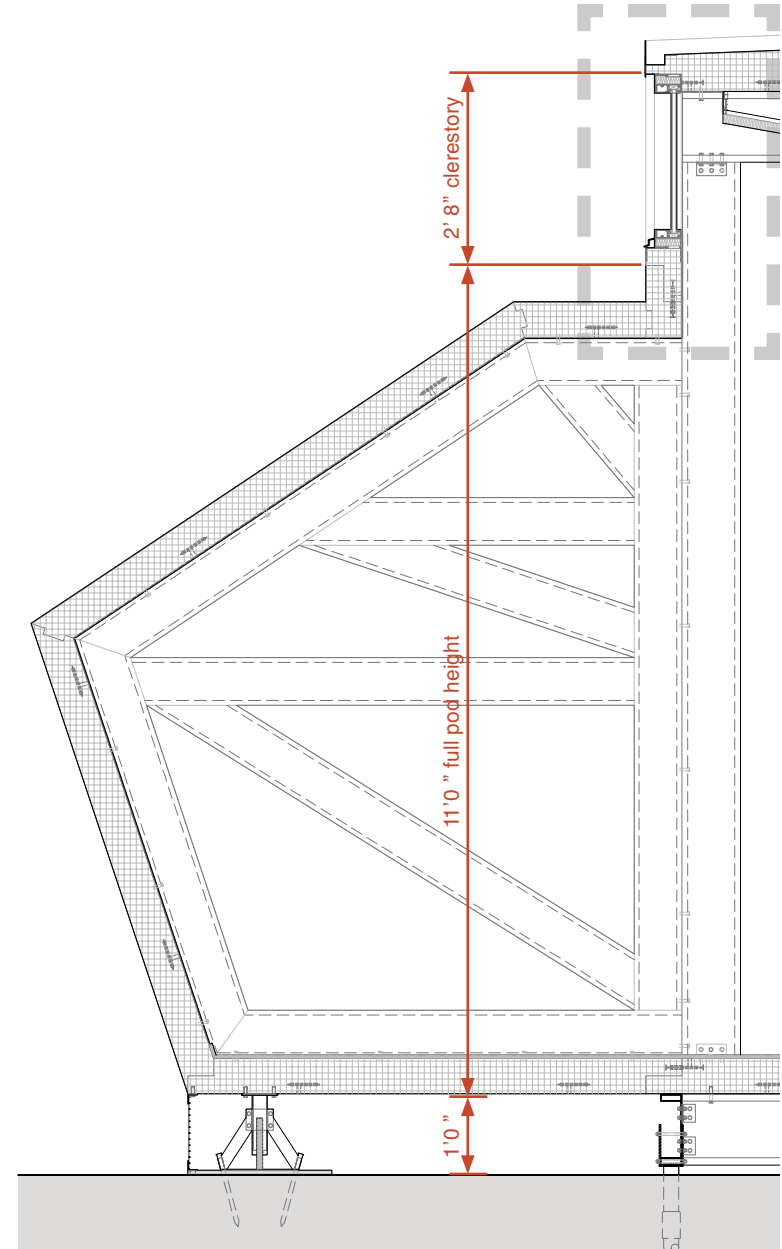
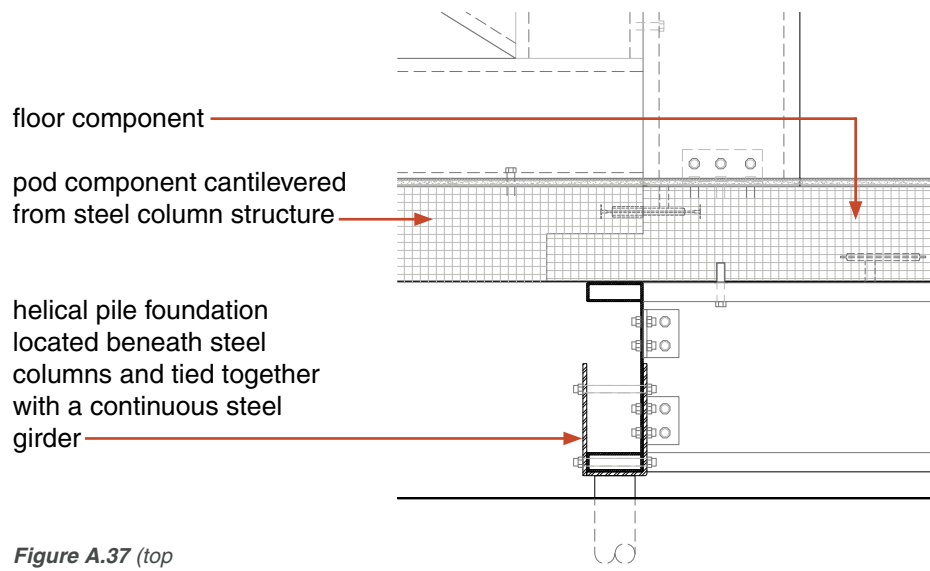


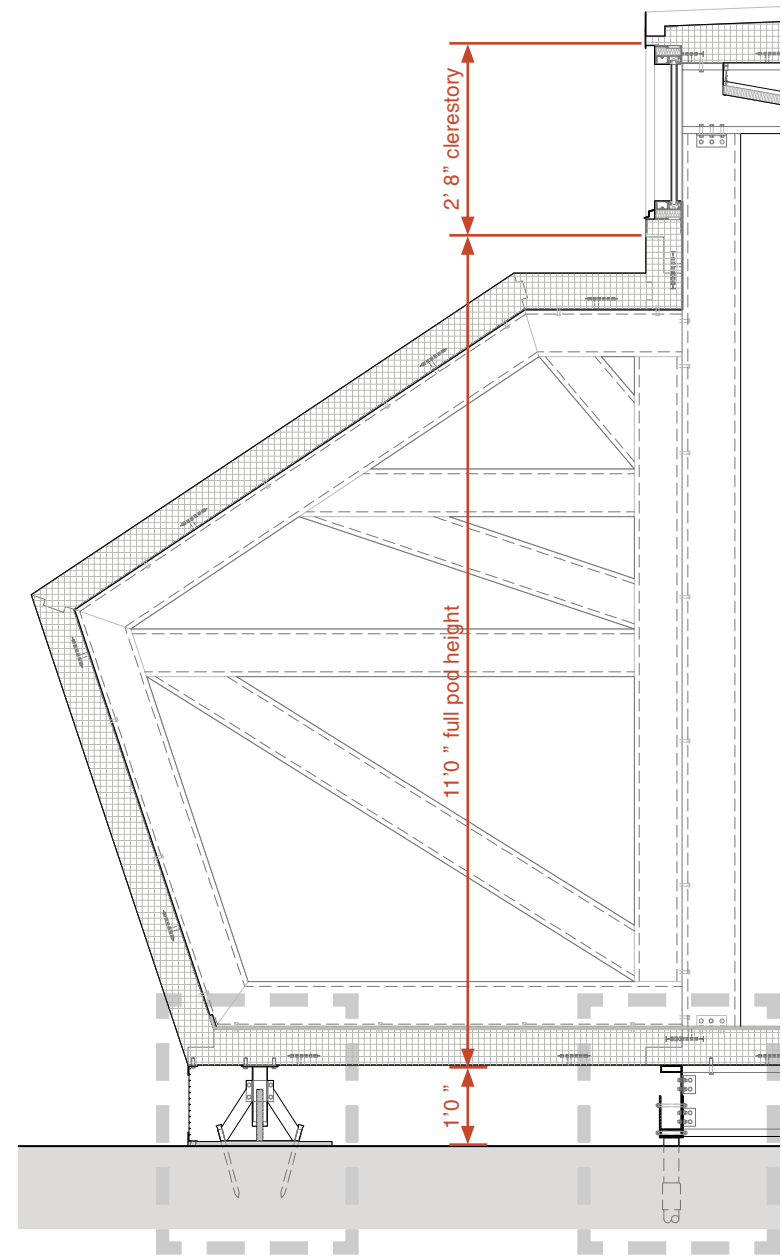
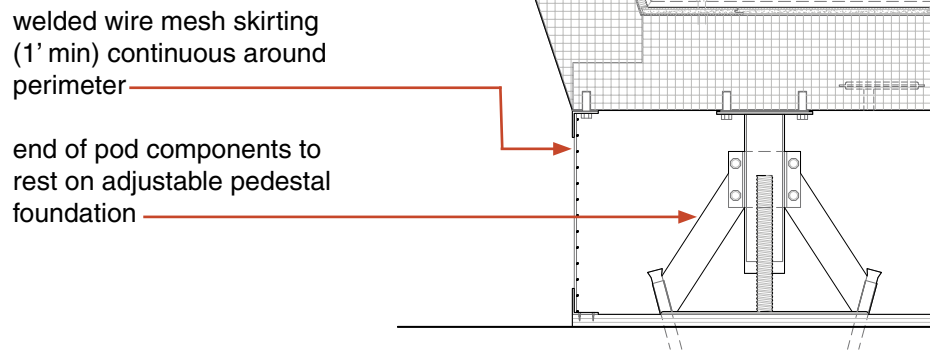
Figure A.36 (right) pod section

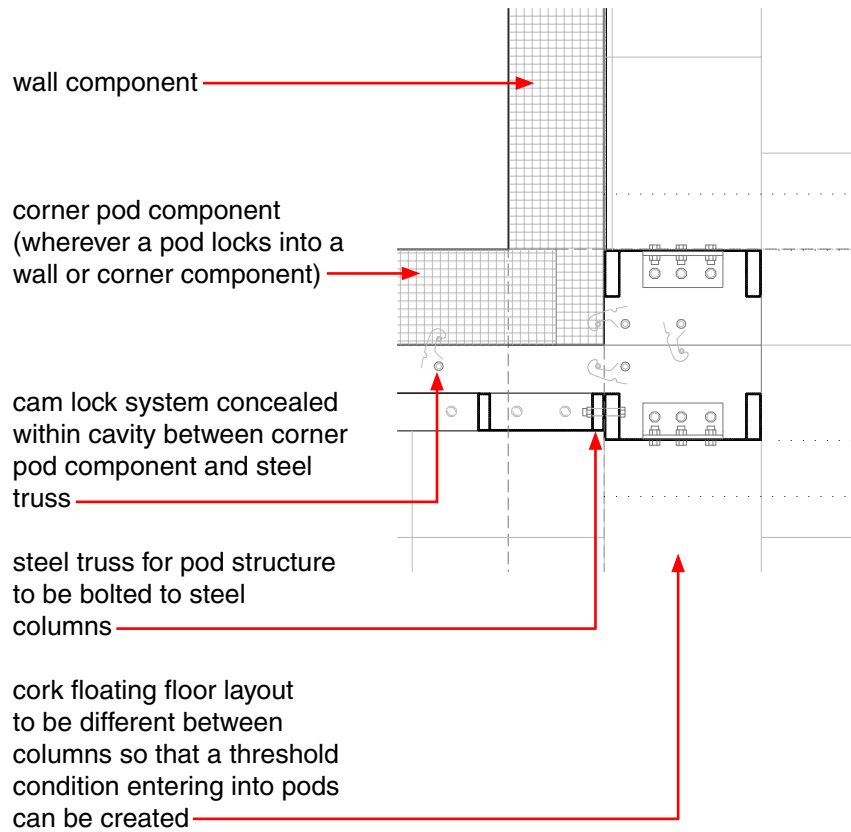


**Figure A.37** (top left) detail of floor component connection to pod

**Figure A.38** (bottom left) pod section

**Figure A.39** (right) pod detail section



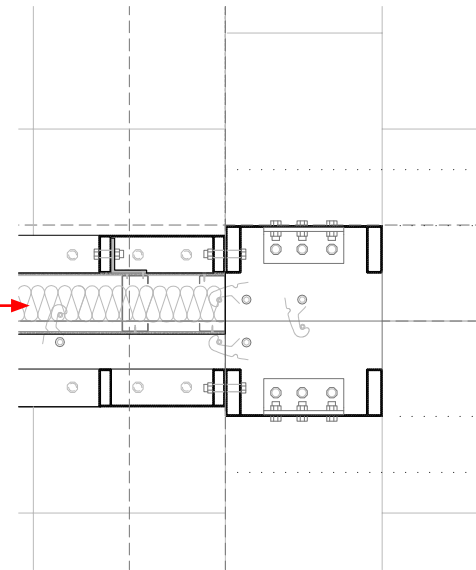


**Figure A.40** (left)  
detail plan of end pod condition

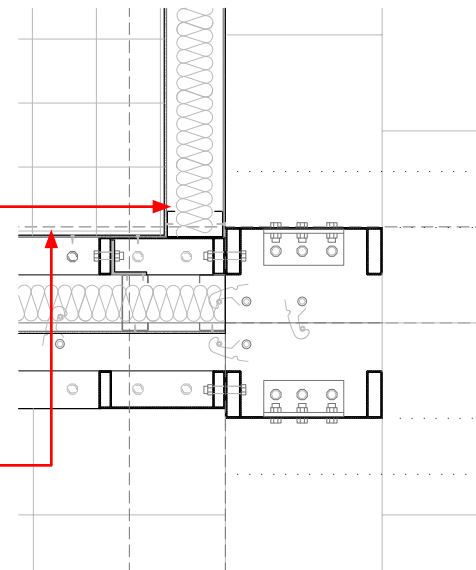
**Figure A.41** (top right)  
detail plan of connected pods

**Figure A.42** (bottom right)  
detail plan of connected pods with door partition

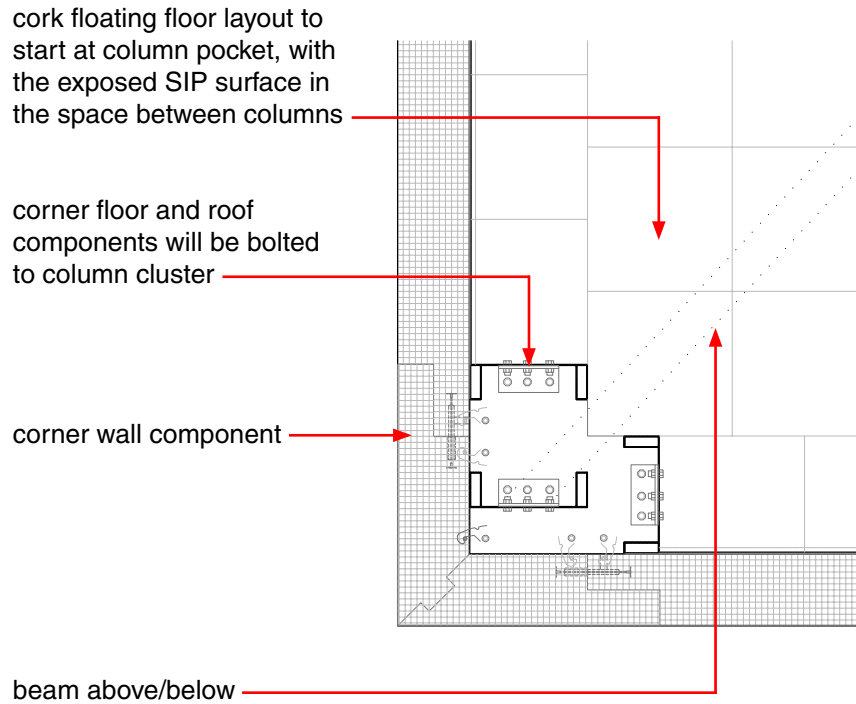
interior partition panels to be used for privacy between pods (consisting of a cold formed steel stud structure, 2" of sound insulation, and two layers of 1/16" magnesium board)



interior door partition added for enclosed spaces (similar assembly to interior wall panels)

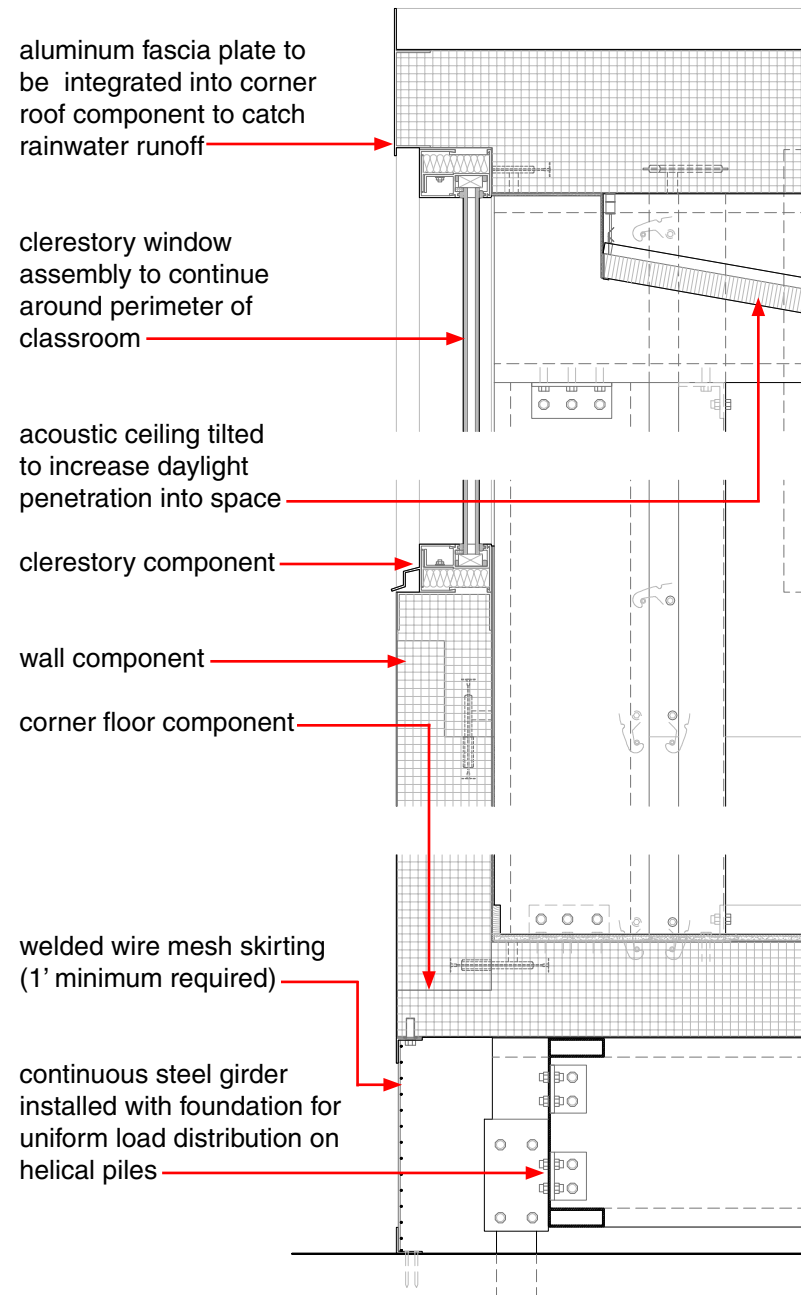


magnesium board finish can be applied to front side of truss if such finish is desired



**Figure A.43** (left) detail plan of corner condition

**Figure A.44** (right) typical corner section





2" sprinkler pipe (pre-fabricated and pre-engineered for simple installation)

2" electrical conduit (plug-and play system integrated into roof components and connected at mate line)

mechanical duct runs to be concealed within dropped ceiling and prefabricated within roof components (transfer to pass through beams)

fire safety system (including alarm, smoke detectors and sprinklers) to be coordinated with lighting fixtures and arranged within gap between roof component beams

adjustable track lighting and strip lighting to hang below dropped ceiling

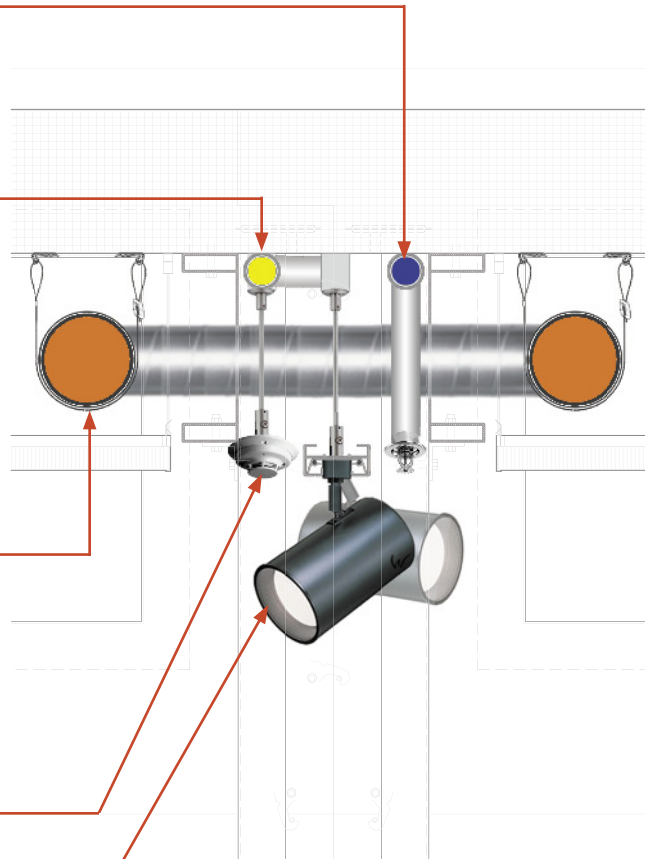
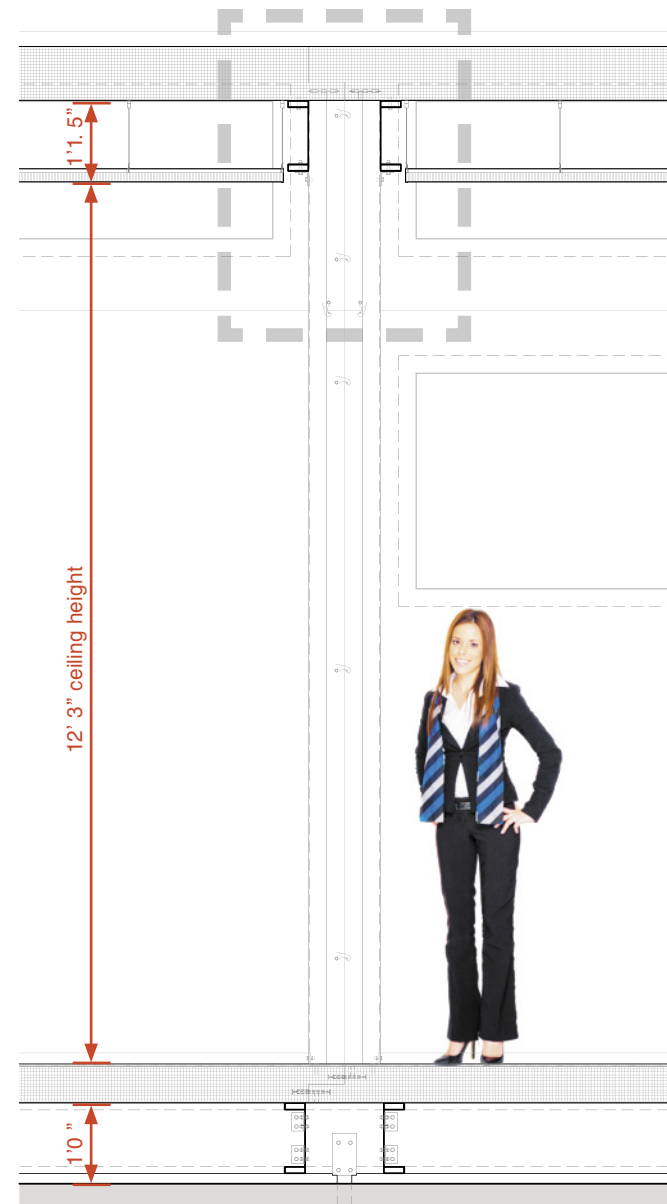


Figure A.45 (left) detail section through beams

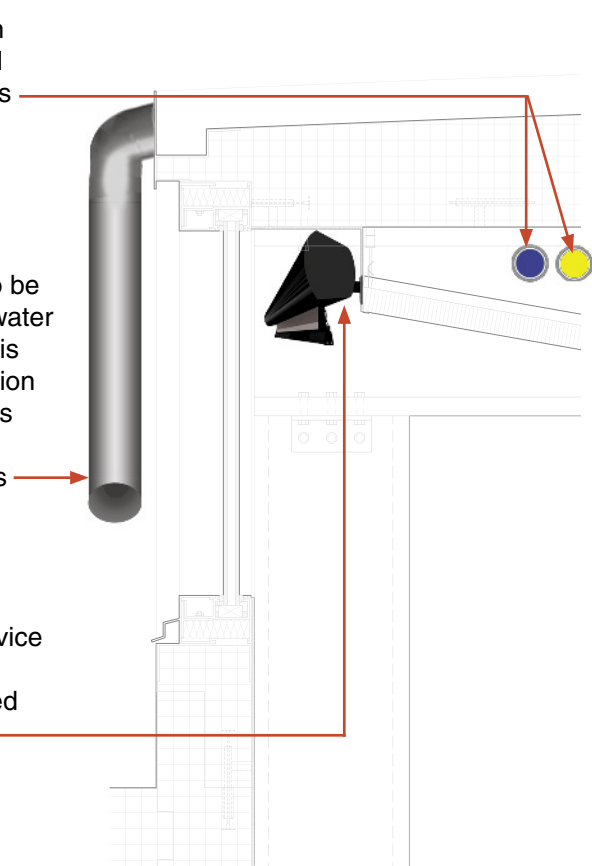
Figure A.46 (right) typical cross section



electrical and plumbing  
transfer conduits to  
be concealed within  
dropped ceiling and  
pass through beams

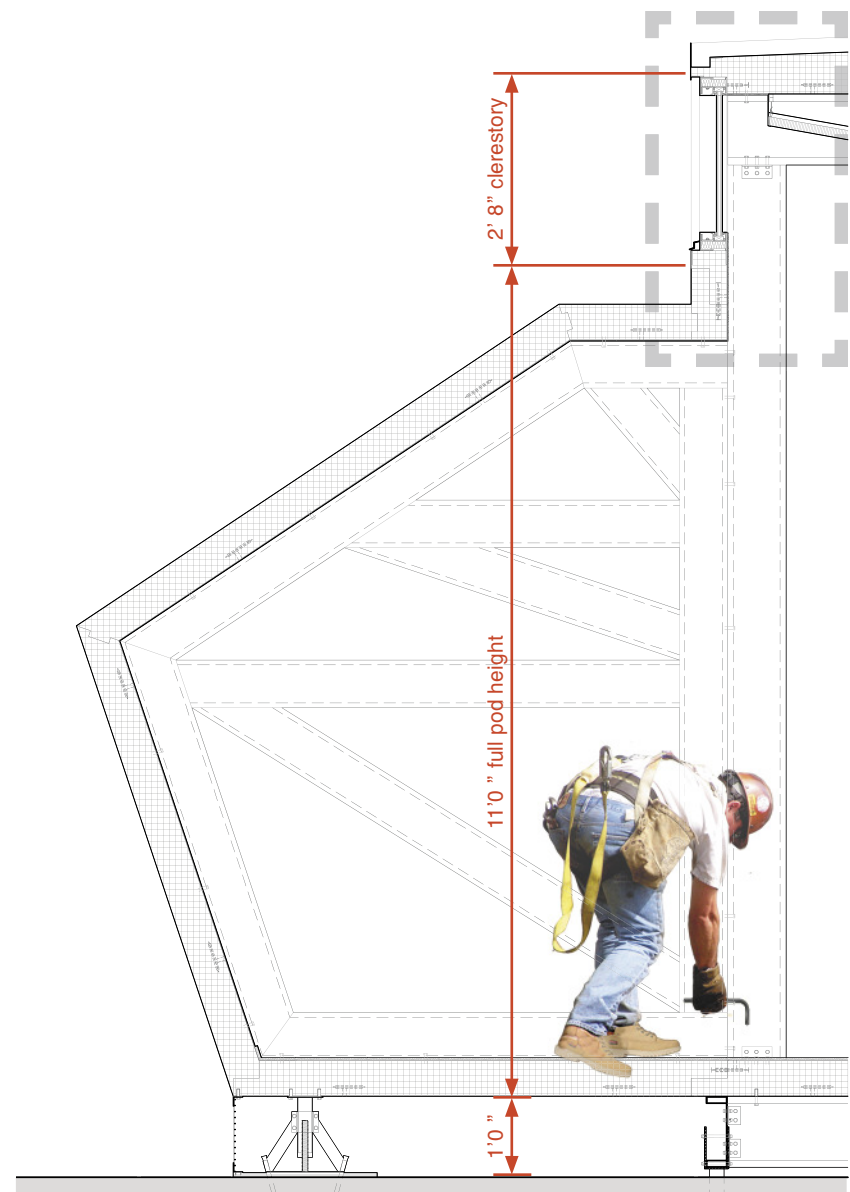
roof water run-off to be  
dispensed at grey-water  
collection pod, and is  
suitable for distribution  
to incinerating toilets  
and outside plant  
irrigation water lines

manually controlled  
internal shading device  
to be concealed at  
perimeter of dropped  
ceiling



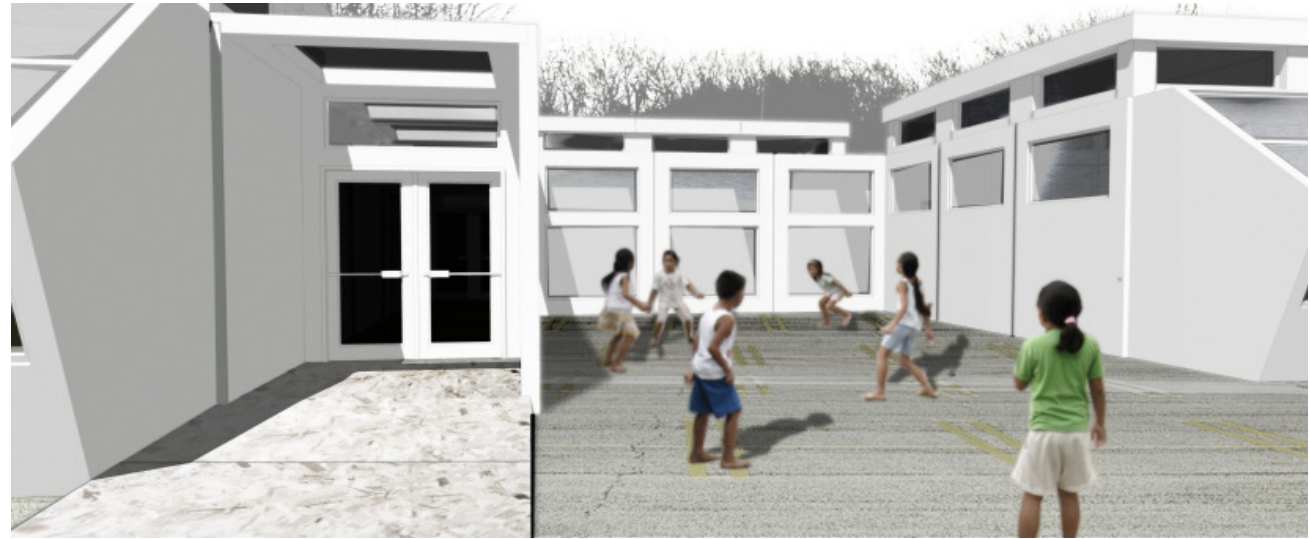
**Figure A.47** (left)  
detail section through  
clerestory

**Figure A.48** (right)  
typical section through  
pod



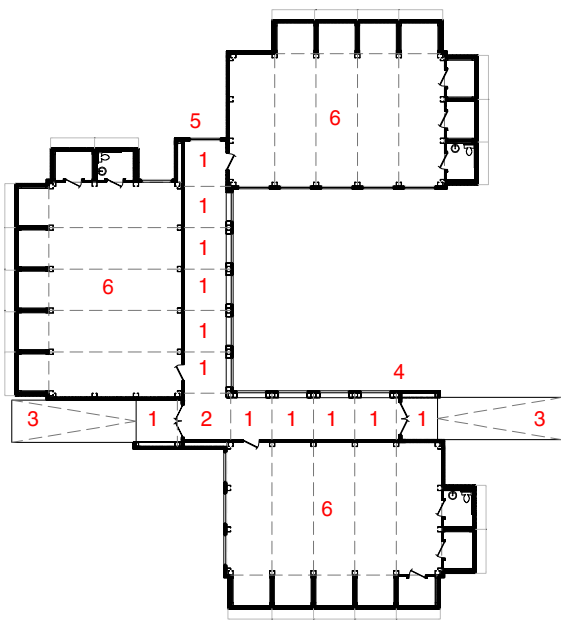
*Figure A.49 (top)  
photomontage*

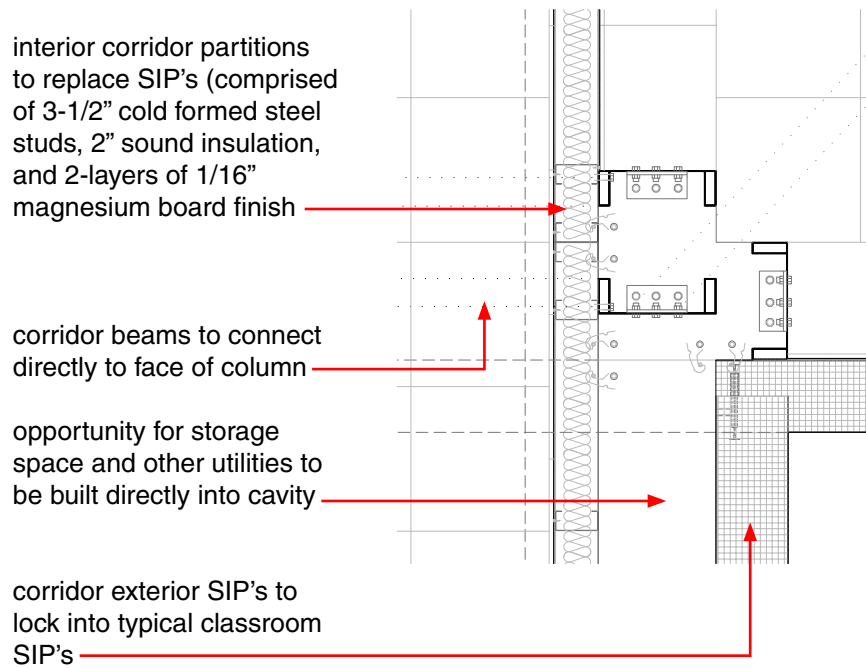
*Figure A.50 (bottom)  
plan option*



**Floor plan for three classrooms:**

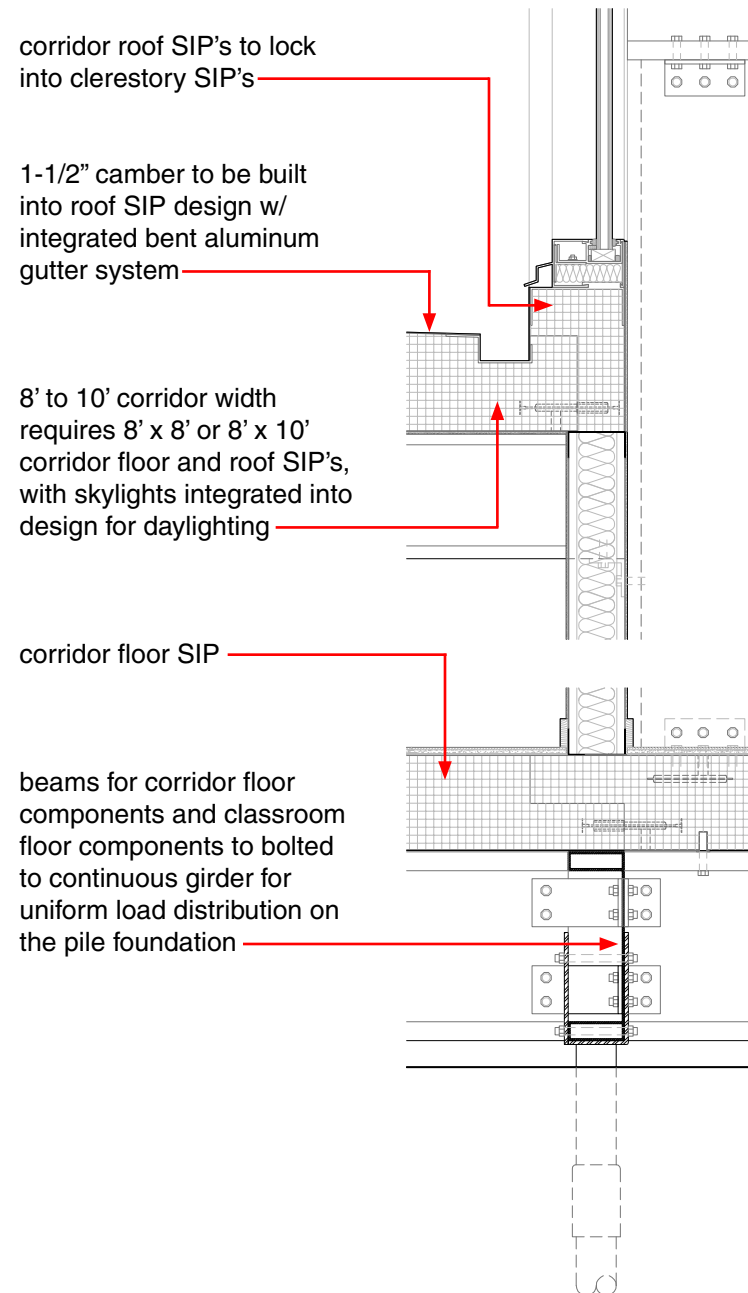
- 1 corridor floor and roof components (8' x 10')
- 2 corridor corner floor and roof components (10' x 10')
- 3 ramp with 1:20 slope (no handrail required)
- 4 entry door wall component (8'-2" x 10'-6")
- 5 corridor wall component (10' x 10'-6")
- 6 26' x 32' classroom





**Figure A.51** (left) detail section of classroom connecting to corridor

**Figure A.52** (right) detail plan of corner component connecting to corridor



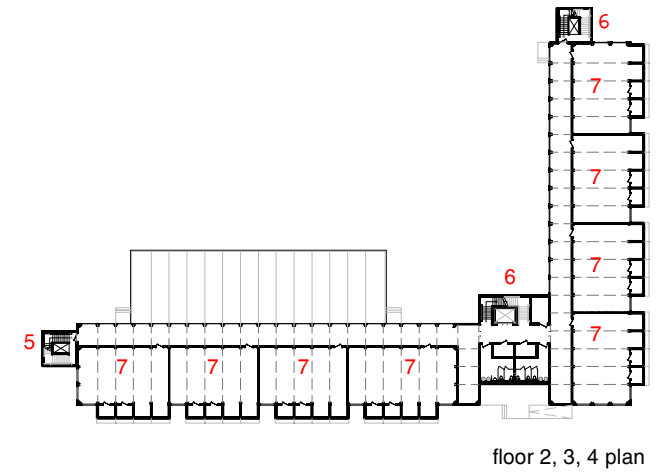
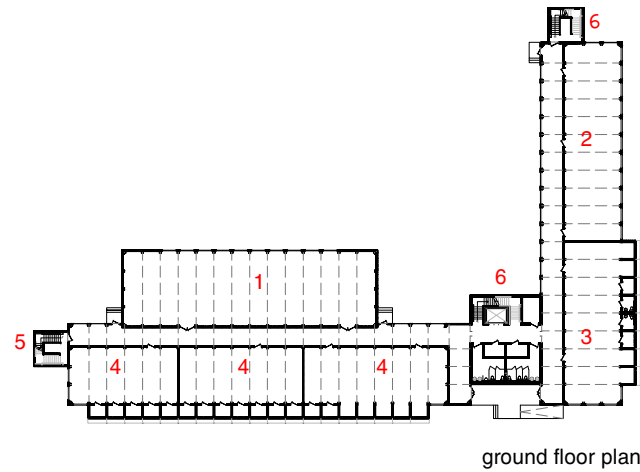
*Figure A.53 (top)  
photomontage*

*Figure A.54 (bottom)  
plan option*



**Floor plan for 20 classrooms:**

- 1 gymnasium w/ 24' ceiling height and columns, 32' floor and roof sip's, access to potable water, and skylights
- 2 cafeteria/auditorium space
- 3 administrative office space
- 4 large classroom space for visual arts and music
- 5 precast concrete stair tower (to be fabricated offsite and shipped to the site, additional foundation work required)
- 6 onsite cast core tower including restrooms, elevator shaft, janitor's closets, and a central mechanical room
- 7 single classroom

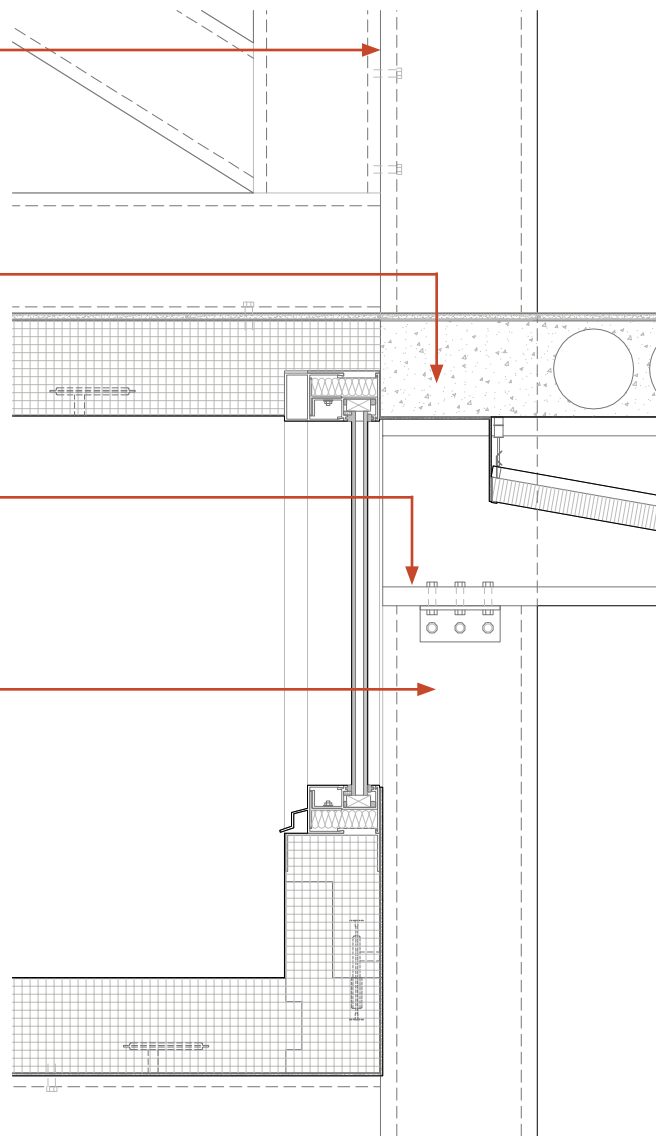


pod structure cantilevered from column with a bolted connection

a different floor system will likely be introduced in stacked systems (precast concrete hollow core plank drawn)

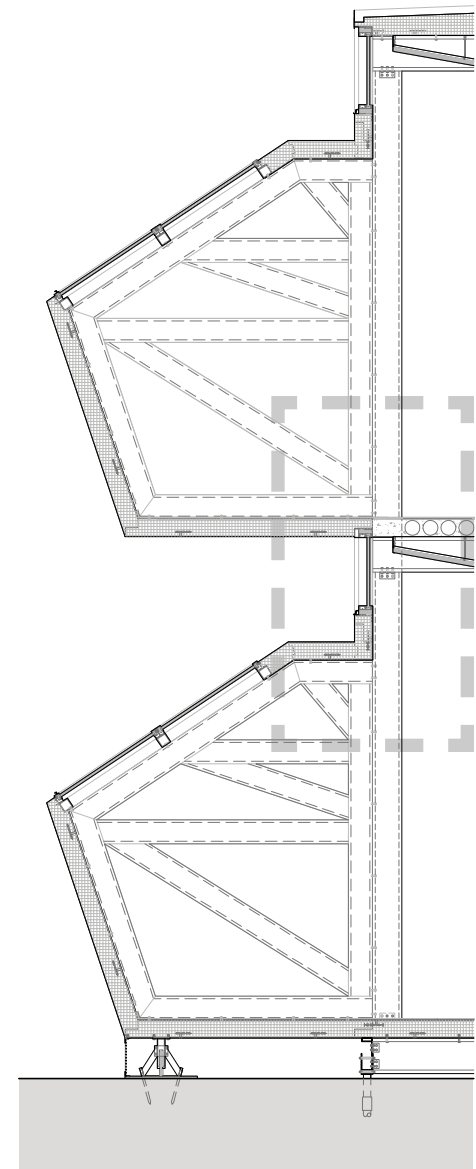
floor components to be bolted to column structure

columns to be continuous passing through slab structure



**Figure A.55** (left) detail section of stacked pod configuration

**Figure A.56** (right) section of stacked pods



## APPENDIX B.1: TRANSCRIPT A

Company A Meeting Transcript  
No. of Stakeholders: 3  
Type of Interview: Face-to-face

**Q:** *While proposing an innovative design solution for this building program, it may be impossible to compete with the facilities commonly used in terms of initial building costs, yet are there other strategies and long term cost savings that can be used to market the proposal? For example, are users factoring in life cycle value into their design to move ahead with a more expensive facility?*

**A:** [In terms of] initial building cost versus life cycle cost, like [what was] said when we were going through the production facility, when this industry started out it really was just [for building] field office trailers, and it was very time sensitive and cost driven. In other words, the lowest cost producer got the orders. There wasn't a lot of care or consideration. [At the start of the industry there was very little involvement from architects and engineers] until it really started to evolve. So, it was just really just a bunch of guys that had construction experience that saw an opportunity. Instead of building these shacks on construction sites, everyone saw need to be able to produce a trailer that could be moved from site to site with [some] consideration as to how long it is going to last. When it started, we didn't even put trim around the windows. We stained the 2x4's a walnut stain, creating a very rustic environment. Now, as the industry has started to grow, we see more involvement

[from architects], requiring us to hire some professional engineers. Because now, all of a sudden, we are designing buildings that need to span 60'; and similarly the codes are evolving, thus requiring us to meet certain roof loads, wind loads, and seismic requirements. These are requirements that everyone else that was building onsite were already complying with. So, through that evolution, we can build larger buildings, and we are starting to be able to do some things that you can do onsite. Schools and education [facilities were] the biggest natural evolution. But as the difficulty of the product has evolved, cost saving have become less and less important (although it remains very competitive, we lose custom projects, for example we were \$10,000 higher than the competition on a recent project). Although cost is still a big player, it is becoming more and more important to the dealers or the end users to evaluate the experience of the manufacturer, the quality of the product, and the service provided.

**A:** Also whether or not they can get it done in the given time frame.

**A:** Yes, delivery times. And we are beginning to see more and more involvement through architects, which I think is great because it is creating more opportunities for our industry. We're working with [an architect] on developing a new concept for a classroom buildings. And because of the life cycle value of the materials that they are using, it is being designed up

front to last 25 years. This is in contrast to the materials that we have historically used (especially in the early days) where there was no consideration as to how long it was going to last. So the materials that are being specified by the architects are considering life cycle cost up front versus costs down the road – eg: how long it is going to last, how am I going to have to maintain it, green requirements, recycled content of materials. With this idea of mass customization, they are coming up with a concept (similar to what you have here) [involving] a standard of modules and add-ons [where] you can create a 10,000 square foot school addition or a 1,000 square foot school out of those [select] components. With the way that the roof is designed, it won't matter how many you have side by side, end by end, and so on. My opinion on market perception is that although I think that the perception is better than what it was 20 years ago, as well as knowledge of the product, the end user still thinks that by going modular it should cost less. This may have been the case back in the days of building mobile homes out of 2x2's versus a home out of 2x4's onsite because it was a lower cost alternative. But as the code requirements have come on, as the abilities of the manufactures has strengthened, and as [we] are getting to the point that we are doing a lot of permanent modular buildings where the only difference between that building and that which would be built onsite is that we build it in a factory and it is shipped to the site (though some of the finishes are done onsite). But now we are using the

same materials that the site contractor would use, therefore, our costs aren't going to be any less than there's necessarily because we have to compensate for freight costs (although we may have a gain on labor because we are not paying prevailing wages in the factory). We may [also] have some efficiencies were we start time wise. [The client can] see the savings on the back-end from production efficiency.

**Q:** *So what is the driving force for interest in modular construction? Are people interested in going modular because of craftsmanship or time savings primarily, or even sustainability points?*

**A:** My opinion is the time, how quickly they get a completed building. It is also becoming better known publically.

**A:** If you look at a construction schedule, they have to do the site development, put the foundation in, put the utilities in, and start building a building on top. For us, as they are doing the site foundation, we are building the building at the same time. So the goal is that when the foundation is traditionally ready to start building the building on top of it, we have buildings already built that are shipped and set on that foundation. People will throw around numbers of anywhere from a times savings of 30-50% depending on the project. If they can get into a building and start turning dollars in six months versus a year, that is huge for the user.

**Q:** *Design innovation in this particular project*

*is largely attributed to the ability for the building to be customized based on a standard set of parts. With smaller panelized components shipped onsite, a greater amount of onsite assembly is required as compared to using larger complete modules. From an economic feasibility and overall craftsmanship point of view, is there a recognizable difference in the advantages and disadvantages to component sizes being designed for use?*

**A:** I don't know that there is an advantage of one over the other; comparing whether more can be done in the factory as site work is taking place versus shipping pre-cut materials to the site and having them assembled there. In terms of time savings, the more you can do to a point in the factory you can get more time savings in the overall construction process.

**Q:** *Is there a greater risk in the shipping of larger components versus more compact components?*

**A:** With these panels, you could ship components on a flat back truck.

**A:** There are probably pros and cons both ways. You'll have more site labor with the building being broken down like this, though you may also have a little more control by shipping these parts and putting them together onsite.

**Q:** *Why would you have more control there?*

**A:** You probably won't have your [as much finish work to do] where the units would go together.

On a single-wide, however, it wouldn't matter.

**A:** As you're putting it together it is being finished (with the larger modules).

**Q:** *These panels I expect would be finished also before you ship them.*

**A:** I guess my question was about this construction taking place here, with the floor and the walls and the roof, on whether or not the plan was to do the finishing onsite or in the factory? When I looked at it I assumed that these pods would be completed in the factory to be attached onsite to the SIP's panel portion of the building.

**Q:** *I feel as if you have more control if you finish all elements offsite and wrap and send them to the site for assembly.*

**A:** So you are really saying that the panels would be produced in the factory so that you have more control over the package of what is going to the site. [Okay, that should work].

**Q:** *Do you tend to run into problems with the transportation of your modules?*

**A:** Not very often.

**A:** We can have some issues where we have tires blow out, or a driver hits a bridge or a tree.

**A:** Yes, driver error. Or if you get into a very rough construction zone for instance, and you



have to haul these into that rough area because they will bounce around pretty good. These things can also get damaged by tree limbs.

**A:** In our design, we try to take all of that for the most part into consideration, by putting additional strapping onto the building to keep it more rigid.

**Q:** *That is why you used this expandable spray foam to reduce the number of nails used and prevent them from coming loose.*

**A:** It takes place of nails pretty much. We still nail the siding because we can't get in there to spray foam it, but the gypsum we spray foam. We'll nail it at the bottom and at the top.

**A:** That way there are no exposed fasteners.

**Q:** *So the finishes are predominantly glued in place.*

**A:** That spray foam was actually developed for this industry, so it is not something that was off the shelf and used in onsite construction. It is a tough product; if you have a damaged panel, it is tough to get that off. I think that helps add to the rigidity of the structure as it is going down the road.

**Q:** *Is a prolonged fabrication schedule feasible? Is it reasonable to have a manufacturer produce a large volume of components one year, and a select few replacement parts the following years, or is the plant designed to accommodate one assembly line system that requires a lot of*

*effort to overhaul and change?*

**A:** The more repetition you have the better the system works. The downfall to it is that if one mistake [is made] on a big project, then you have a big problem. On a smaller project, it is not as prevalent. But, in the process of the plant, if you have 100 modules you efficiency does go up.

**A:** Quality as well, because the guys are doing the same thing over and over. If we looked at this as a system that someone was marketing out in the market place where they would come to us and say that they need one classroom, we would gear to build that one classroom. Three months later they can come back to us and say that they need four more of these pods and more of these panels because now they are going to build up to a 30 classroom complex. So, it is kind of what we do now in one sense we are a custom builder because we are doing different things all the time. In [our] facility out here, [we] can have (depending on how large the project is) two or three different buildings going on at once (though in progression or at different phases in the assembly line). This one, for example, could be a three-piece office building, and the one behind it could be a 10-unit daycare, and the one after that could be a toilet unit. So we are kind of custom manufacturers in ways because we are geared to switch over from one type of building to another, versus someone who I would call a modular home builder who will always use 2x10 joists, and 3/4" plywood or OSB, etc. They use the same components, and they build maybe

half a dozen models.

**A:** Whereas ours change, and with that change there is a cost associated with it. Like when we start that steel job back there. That creates a slower start process and there is a labor cost involved with that (gearing up the production line).

**A:** And if that is a one or two piece project starting, it is hard to recover from that starting cost. If it is a 20-unit steel complex, the guys are going to get more efficient with it and it is going to start flowing and labor rates are going to start coming back in line. But if there was a facility dedicated to the SIP's manufacturing, it would require volume to make it cost effective. For example, [a manufacturer that] builds bathroom pods will build a pod that is finished from the inside for a handicap bathroom, or a multi-user bathroom, etc., and then it is plugged into a site-built project. Their whole production facility is full of these and they are essentially building over and over again the same thing; that is what that [type of] facility was geared up to do. It is really based on how you gear up your building based on what you are going to be doing. We are geared up to do custom projects.

**Q:** *Does the plant set up ever change?*

**A:** No, that plant will always be set up that way, unless we decide we want to change it. Right now that plant is set up to do any particular building we can ship over the road.

**A:** And the plant will evolve over time as the market changes too. So, for example with foam seal, the process is a little bit different than when we used nails and screws. So we modify our system and our processes as the market demand changes. When people requested us to pour concrete floors in our factory, we tried it and it worked. Now that we can do it, we have to change our systems – we pour them outside. Our [newer plant] was built for today's newer construction methods in mind. As the materials change (concrete floors, steel studs, the sidings, the roofings), we've always modified our process while still trying to stay in the seven stations that we've designed – walls, roofs, electric, plumbing, etc.

**Q:** *I didn't see a concrete project out there, how much does the process change?*

**A:** The concrete truck comes in and pours the floor and the walls, but the guys still have to put that pan in; they still have to prepare the floor for the pour. So if there are four guys back there, we may only need two to do that, and we'll push them somewhere else in the plant. It is more about juggling your people and putting them where they're best suited.

**Q:** *Are workers specialized in a particular trade (plumbing and electrical for example)?*

**A:** Electric and plumbing are definitely specialized. And people who have been building walls are better than guys that are cleaning windows. Over time they do become specialized in the area that they work in. The

guy that builds roofs know exactly how to build the roof, though someone can go back to assist him. It is harder to get help with electric because someone without electric knowledge will not be helpful. Same with plumbing.

**A:** I think the more highly specialized the less you can introduce people (plumbing, electrical, heating, and air conditioning). But framing is easier; a guy that can frame a wall knows how to cut lumber and knows how to fasten it, can help someone in floors.

**A:** It comes with cross training. That's one of the things that we do; we want a certain number of individuals to work in multiple areas of the plant. We purposely switch people around to get them experience in various areas.

**A:** Which helps a start-up situation like steel walls. If you throw a couple more guys back there to get walls moving, or if you get behind in one area and ahead in another area, the ability to move labor around is really important.

**Q:** *To what extent is BIM being used in your process today?*

**A:** [We] don't use BIM at all. In our situation with the projects that we do the design and engineering on time is a factor, so familiarity with the computer software used is necessary. On a [recent] 26,000 square foot building for example, we needed to be able to design and engineer it within 2 or 3 weeks completely. So, when I think about BIM and introducing it into our engineering department, I believe

that the whole process would have to change somewhere ahead of us. But the problem with that is that at the stage they don't know our processes and how we do things and how we design our frames, walls, roofs, standard details, etc. I can definitely see the benefits, [as our General Manager] has something going down the line and he says, "I have a recess and it's going to be covered by chalkboard," or "I've got a window that is not going to fit where you have put it," or "I've got ducts interfering with lights." However, how you introduce it into our industry is going to be a challenge.

**Q:** *Are you already considering when the integration of BIM into your design process will take place?*

**A:** You have to see when something like that is working its way into our industry. Some of the government projects that we are doing require this to be done. How we've gotten around that, isn't the way it was intended to be used, is that is being done after we build. It's only being done because the government wants that in their files just so that they know where all the utilities are. So that is really the extent to which we are using it – as an after the fact application because of the time associated with its integration. Engineering is a lot like a production facility. They have an order come in, they have to draw it, it goes out, they have another order come in, etc. There is a process that has to follow because they'll send a set off to the state of Ohio, get comments back, address them, etc. There just isn't a lot of extra time to be working on altering the process because

each new project coming in is custom. An 8-unit wide can be drawn in a matter of hours now, and that is a 30,000 square foot project. If someone were designing a standardized product like this (the case study project), and everything was designed ahead of time coming into our process, and we were building to match the details and tolerances already set in front of us, I'd see it as an opportunity to introduce BIM into our fabrication process. So, in reality it depends on how big the project ultimately is for us to consider altering our process because again there is a high start-up cost associated with changes.

**Q:** *How much of your work is designed by outside architects as compared to buildings designed and engineered in-house?*

**A:** Schools tend to go to an architect for help.

**A:** A lot of the work that we do are designs for site building that we turn into a modular concept ourselves. This happens a lot. [We aren't] getting upfront designs from architects [often], outside of the schools, it seems like it is happening more and more, though, as the LEED certification system is developing interest. I think architects are beginning to see modular as an already inherently a greener building process because it can be relocated, and there is assumed to be less waste because we are buying a lot of our materials sized for the project. [One architect], for example, sees a need for a modular component process for a school system, and they've gone out and found one of our dealers that is promoting that type of

project. They look at who they want to put on the team to develop this whole concept, market it, and build it. So we have [the architect], one of our dealers, and us that we're hoping to kick this project off pretty quickly. In that process, the architect already understands modular, he's been doing all of the drawings with that modular concept in mind, so when we actually sit down to start to engineer it, a lot of those things should already be worked out, making it a smoother process. But as far as the percentage of architects that design modular, I doubt it is even 5 percent.

**A:** A lot of times we are taking an architect's drawings and trying to right off the bat make it more modular friendly with the floor plan in order to send that out with our bid.

**A:** [Our] guys will do a floor plan with more custom type projects that they've had to take in and make it more modular just so a customer sees what they are getting by going modular versus a site built project.

**A:** And even some times when the architect is thinking modular, the sizes maybe aren't quite right, so we'll just take that concept and do a new drawing with our size of modules ultimately coming through with the same thing, but more friendly to our process.

**A:** And the limitations as far as widths and lengths and heights. We get a lot of requests for 9' and 10' ceiling heights, but that is tough to achieve when we have to get it on the shipping height of 13'-6".

**A:** We can ship 14' in Pennsylvania. In North Carolina I'm not sure if there is any height requirement. But in Pennsylvania for example you have to stick within the regulations of 14'-2" that the state highway system requires.

**A:** So that is a challenge too, understanding where the module is going to be built and what states it is going to have to pass through to get to the site. For example, if [we] could get out of the state of Pennsylvania and get into Maryland, [we] can maybe ship 14'6" through Maryland, but we can't even get out of Pennsylvania, so we have to build it in North Carolina so that we can get it to Maryland with a taller building.

**A:** Connecticut again, for example, only allows 13'6". And in Massachusetts, though there is an exception for schools, the maximum height is also low. You can get exceptions through the people who issue the permits – the Department of Transportation. They'll issue a permit for the school. But it will have to take a different route to accommodate low bridge clearances.

**Q:** *There are four basic component types, a rigid skeleton that is constant including the columns, floor and roof components, and the flexible wall and 3-dimensional pod components which are interchangeable.*

**A:** [For] the SIP's panels themselves, [we] would go out and find someone that manufactures those for us. For the different components, we would outsource that work and have it delivered to us ready for assembly. Likewise, we may buy the SIP's walls, floors, and roofs

and do the assembly here with the cam lock system. Unless we had a plant dedicated to SIP's manufacturing because there was a huge demand for the product and it made sense to have our own plant dedicated to the SIP's. Like the RV companies have done over the years, they used outsourced work for laminating their side walls. A lot of them are bringing that work in house now to lower costs and to control quality. So, a lot of these components we would buy from someone else, and do the assembly and packaging in house.

**Q:** *What then is the role of an outside general contractor on site, or do you include that work within your own scope?*

**A:** Yes, there would probably be a separate general contractor. For example, if we build a building and it's been qc'd by a third party or the state, and you have a nice looking building, it sometimes ends up on-site and our dealer has hired someone that is less than qualified to assemble it. We run into a lot of problems with that because they often don't hire a general contractor that understands modular construction, [and therefore] don't know how to slide module units onto a foundation, or possibly how to crane set them. And that same guy that is doing that may be tasked with doing the plumbing crossovers and may not be a plumber, or with doing the electrical crossovers and he is not an electrician. So that is a big challenge. We don't have any control over that.

**A:** That is price driven too, and the cheapest

guy isn't necessarily the most qualified guy. So it is a battle that we go through quite often. We have what they call 'quick connects' for our electrical where the wires are already hooked up and you just plug them in. Plumbing for the most part is still using copper supply. So it still has to be connected and we aren't shipping any plumbing stuff loose. Whether or not they are using those quick connects that I know they have, I don't really know (both copper to copper and copper to plastic).

**A:** There are other products out there like the Peck's system which is supposed to be a lot easier to use; you can cut it, put on a fitting and a ring, and put the two together with a crimp tool that crimps it down. But a lot of places we ship to require copper supply. So, if there is a system where a non-plumber can put together a simple system with this pipe to that pipe, tighten this, check for leaks and they're done. The easiest the system is the better solution for plumbing systems because the lower cost worker is the guy that will be putting it all together.

**Q:** *Therefore does it make it easier on the process as a whole, to begin to assemble larger modules offsite before shipping so that you have more control over the final quality because you are reducing onsite labor?*

**A:** That is probably better because again we are using skilled labor to do those functions. The more plumbing we do in-house, the less problems there should be onsite. It has been tested, checked, signed off, etc.

**A:** We check the final assembly here even if it is multiple modules; we'll plug them together for testing. And we'll fill the system with air – 100 psi, for example, having to sit for "x" number of minutes, and if it holds that pressure, we are good to go, but if it loses it, we have to go and find that leak.

**Q:** *So, because you are in charge of the quality, it is important to do full mock-ups offsite.*

**A:** Yes, and this is in contrast to a bunch of small interconnects that cross every "mate line." Depending on who you are using as the onsite contractor, I would assume that they do air tests as well. But they will call us because there is a leak and the only reason that they've found that leak is because they turned the water on before they've air tested it. So, yes that is one of the bigger challenges – the coordination of offsite to onsite plumbing.

**A:** They usually don't air test them on sites, and instead just turn the water on. Really, any type of water infiltration is a big challenge.

**Q:** *How much finish work do you typically do offsite?*

**A:** It depends on the project, but the majority of what we do will include a finished vinyl wall covering and a hung ceiling; it will include the floor covering and the mechanical system. However, the more permanent modular buildings we're doing less finish work – we're putting up raw gypsum board that is taped and painted in the field. We're doing all the wiring

above the suspended ceiling and then attaching the lights to the sub-ceiling, so they will place the lights and the diffusers in the field as well as infill the ceiling panels. We probably do the same amount of electrical and plumbing on these big jobs depending on the requirements of the heating and air conditioning system (how complicated it is). Though, we may run all of the duct work, but not install the HVAC system especially if it is a roof-mounted type unit. It really is what happens at each module line that is unfinished and what the detail is to finish that in the field (what you bring across that “mate line” and how you trim it out, etc.). In the ceiling grid, we may install the two longitudinal t-bars and in the field they’ll put the cross bars in and drop the tiles in.

**Q:** *What are the challenges at the interface between offsite and onsite construction? Or at the interface between architect and the manufacturer?*

**A:** It is important for the architect to realize what they are getting in the factory. A lot of times they don’t even have our prints at the construction site. We furnish our prints, they don’t have them onsite and they’ll just be doing what they think is right.

**A:** [For example, one project we had] was a very nice building [with] the exterior siding already paneled with all different colored panels, and whoever they hired to finish across “mate lines” (we held panels back at different distances at these seams) were trying to do that without a set of plans.

**A:** They had the architect’s original set, but they didn’t have our set which shows what we are doing in the factory and what they have to do onsite. They didn’t have that.

**Q:** *Is there always going to be that supplemental set of drawings that you are producing for each project?*

**A:** Yes, shop drawings. This is a case where the dealer has to get the drawings to the guy who is setting the building up at its final construction site.

**A:** Using an example, [the architect] did design [this one] building to be modular, but because of our little differences in our manufacturing processes and what we can and can’t do in the factory, we have to take their set of drawings and come up with our shop drawings. The architect’s drawings were close, but we had to alter them – he specifies 11’-10” modules, but when we look at it, we need to make it 11’-9”. Or maybe he specified certain things to be installed in the factory, and it really needed to be installed on the site. So we’re taking that and we need to turn it into shop drawings for a customer approval package that does go back to the architect and the owner [for] a review. They’ll look at the drawings and determine if these drawings follow the design intent. I don’t know that the architect will be able to take it to a show drawings level package because our engineering group has to show their drawings just a little bit differently at each plant based on how they build and the drawings that the workers are used to handling.

**A:** We have an approved system package that we have to adhere to because it is being checked by a third party. That is not always taken into account in the stuff that we get from the architect.

**A:** In our opinion, we don’t feel that they do any of the pre-planning that they need to do before the modules arrive. And, on larger and more complicated projects that we know it is going to be very important to have communication, we have invited the contractor to come to our facility. We’ve [even] offered to meet with them offsite somewhere in the middle just to go through what we are going to be doing in the factory and what they’ll be expected to do in the field. But it doesn’t happen very often. We do that internally, where we’ll have our own internal pre-production meetings, but getting the two together doesn’t happen very often. And it should happen on any project that is custom in nature. [But] it is time consuming. We are offsite, and if that contractor traveled to our facility, then he is not onsite working on projects. And likewise if we are traveling to meet with them, we are not doing our work in house pre-planning. So it can be a challenge.

**Q:** *What are the typical problems with the designs sent to you by architects?*

**A:** Height limitations a lot of the time; also the type of roof system that they want. If I remember correctly, on [one particular school], each classroom was two modules, and they wanted the roof sloped. Well, they wanted a certain ceiling height and a certain slope to the

roof, making the building about 16' tall. We couldn't ship a building 16' tall into the state of Massachusetts. If that was built on site, then obviously that is not a problem. So it is mainly heights; the ceiling height that they want versus the type of roof system that they want. And a lot of times now we have gone to roofs being put on the buildings afterwards onsite because they want it taller (eg: wanting a 4-12 roof slope).

**A:** The module widths that we can do include anything up to 16'. However, it might be more economical to divide up the modules differently than how they've laid it out.

**A:** Architects coming into the industry will need to educate themselves on shipping limitations, what makes sense to do in the factory, what doesn't make sense to do in the factory, etc. And it seems like the more and more architects that I talk to, they are now getting that type of education in school, probably due to a peak in interest in the industry.

**Q:** *Can you list examples?*

**A:** We don't do brick because it adds too much weight. Weight of materials is a problem in terms of shipping constraints.

**A:** Though with concrete, we'll pour a 3 or 4" slab, but the limitations then are that the modules are smaller (up to a 12' wide 56' dimension instead of a 16' wide by 70' or 80' dimension for a wood floor construction). So there are shipping limitations based on the

weight of the materials you are using. And what will hold up during shipment and what will not.

**A:** Now, if you are doing a big building made of many parts that requires a larger amount of onsite labor, do you want the building to be shipped with carpet on the floor where your subcontractors will tear up and muck up.

**A:** And we recommend doing a suspended ceiling in a room like this that doesn't cross any module lines. But if you are going to put a suspended ceiling down an 8' corridor that is 100' long, for example, it is harder to expect that line up after final construction.

**A:** Or if you are expecting a lot of work in that ceiling to be done onsite, and you finish the ceiling offsite, your subcontractor may need to tear it apart to get access. We find that all the time.

**A:** A lot of times we'll put the suspended ceiling in with the assumption that we're going to be doing the sprinkler system in the factory; but if they want the sprinkler system installed onsite, it therefore doesn't make any sense for us to install the ceiling offsite. So we'll tell them that they'll need to include the ceiling also in their scope of work. It's not tough stuff, but thinking about the work you are going to be doing [is important].

**A:** And I would think that the way you divide up systems and finishes would change depending on whether it is a temporary building or a

permanent building.

**A:** Our standard set of details take that into consideration. With a temporary building, for example, that we know will be put together and taken apart, we will hold the drywall back (the vinyl gyp with a rolled edge), and in the field they will install a 12" piece over the module line, and they'll put two batten's over that seam. Because that is a temporary situation. When they pull it apart, they'll pull the trim off, pull the vinyl gyp out, and the insulation out, take it to the site, and put it all back together. This is in contrast to a permanent modular building where we may have raw gyp in two full sheets run all the way to the "mate line." And so they can run the gypsum all the way to the corner seamlessly, and we'll provide the materials loose in the modules for them to use and cover up the "mate lines" because they won't be needed for deconstruction.

**A:** Depending on what makes the final product look better, you'll hold off on the finishes offsite so that you can place a full piece in when the final assembly is put together making the module lines less recognizable. We'll design the sizes of the set-backs based on what the pattern of the material sizes we are using.

**A:** The purpose of the design of a permanent modular building is to come up with a building that you wouldn't know is built offsite or onsite. We're doing some youth activity centers right now with a full gymnasium, 18' ceilings in the commons area, 12' ceilings in the entry area. I walked into the building last month, and you

can't tell that it is a modular building. But we had to design it so that sections of the modular roof were removable, or so that the way that we placed modules around an open area in a way that they could build walls on top in order to get the higher ceilings. That's what we did with the gymnasium; we set modules around what was going to be the gym (serving locker rooms, bathrooms, equipment storage rooms, etc.), and we put the steel 5' x 5' columns in our walls so that they could use that structure onsite to build the upper level of the gym to achieve a 24' ceiling height. So, our experience is getting better, and architects are understanding better about what we can do and what we can't do, and asking more questions. With those project, for example, we had a lot of design charrettes. We are designing 18 of these youth centers throughout the country. We'll do all of the design upfront with the design charrettes with the government's architect, their engineers, their fire and safety specialists, and us. So, we are putting a package together before we are even starting to build where everyone ahead of time knows what their responsibilities are (contractor knows what is to be done onsite, and the government knows what kind of building they are getting, and we know what we are building in the factory). So, the closer we can get to situations like that, with a little bit more work up front and better communication between all parties upfront, it makes for a better project.

**A:** The problem is that most companies don't build that time into the project. They only call us when they want something quick.

**A:** Their marketing strategy is that they can get a quicker building done faster than their competitors. When they realistically could get you a building in 9 months, they may be saying that they could get you one in 6. They'll expect us to finish in 6 weeks with the drawings, materials purchasing, and starting development in the factory.

**Q:** *Can component re-use, re-sale, and life cycle costs be used to justify higher initial building costs?*

**A:** I think that is why a big percentage of our business in our industry is educational use buildings. And I think it is for that same reason you are talking about here –they can buy a double-wide classroom that is very inexpensive, and will last only 5 or 10 years, but it has that flexibility to be moved when enrollment or demographics change allowing them to bring it over to this other school in their district. And they can also lease it, so it wasn't capital costs that they are incurring. I think now what the schools are saying that because of life cycle value, because that classroom that is traditionally \$45 a square foot (at the low end) has this ability to move around or to add onto they can spend \$100 a square foot or \$120 a square foot now. This is because if they're instead making a purchase that is going to last them 25 years instead of 5 or 10. So I think now there is this interest in this industry from architects because they think there is a market for that \$100 a square foot building [thanks to] the influence of sustainability and green buildings right now, this idea of relocatability

(that they can add-on and come back next year and buy 4 more pieces from us and add it onto the building). From a marketing standpoint, this is feasible. Whether or not the schools actually have any money is something I don't know about however.

**Q:** *What is the major barrier in the acceptance of architects to using a modular or a componentized design?*

**A:** I think it's just the older generation set in their ways versus the younger generation coming up and looking for a better way to build. I think this is just becoming more and more an acceptable way to build.

**A:** Compared to 10 to 20 years ago when there was a negative connotation associated with modular construction and that they are getting nothing but trailers produced in the factory.

**A:** We do build trailers, but we also do build buildings. I think it also has to do with the industry just having evolved to where we are doing more and more high-end buildings using the same materials that are being used onsite and the fact that the architect can walk through the building at the end of construction and not even notice that it is modular. I don't think that [the architect for the school we did] had done a modular building before; he tried it, he did a decent job at putting the drawing package together, and they were proud of it when it was completed. And we did some neat things with it in terms of daylighting and exposed ductwork, fiberglass windows, etc. We had quoted the

project as he had specified it the first time, and he was shocked at how expensive it was. Then we met together and brainstormed ways to reduce the cost – removing the fiberglass windows because they are twice the cost of nice energy efficient windows, eliminating the lightshelves, etc. The school district was [ultimately so] excited about the end product, that they put another bid out for four more classrooms. Again they didn't have enough money, so they resorted to the \$45 per square foot units instead.

**A:** For that project, the time frame was too tight. They wanted the building by November, and they put the bid out in July.

**A:** It is tough in the education market, because they don't always know what their enrollment and needs are by location until school is out. And when they start their planning for next year, that doesn't give us enough time to plan; they'll determine they need them in July, but want them before school starts in September.

**A:** And you have a restriction as to our availability as well. If we're backlogged in June, the schools are out of luck in that upcoming year.

**A:** If they don't have orders in, and if the buildings aren't coming off by the first of July, then they will not make a September deadline.

**Q:** *Next, if you had an opportunity to review the drawing package that I sent to you last week, can you please comment on any situations in*

*the design that you think will be challenging from a production standpoint?*

**A:** In the project we are working with [one architect], we did talk about the cork floating floor system. We did go away from it because of the cost, but also the question of how we would treat that across "mate lines." We did not want it to look like the typical double-wide classroom building. Also, we just wanted to do as much in the factory as possible. For example, we may have bamboo flooring on the perimeter and carpet tile in the middle just because carpet tiles can be pulled up along the "mate line" and be replaced. I haven't worked with floating floors before, but when I see \$5 per square foot or per tile, those are high numbers in our industry. However, we are starting to see some of these products today. For example, someone is specifying marmolium for a project we're working on right now which is \$3 a square foot or \$4 a square foot. They just aren't numbers we are traditionally used to seeing.

**A:** I really like the SIP's panel idea you have quoted. I like the idea where the exterior and the interior are part of the SIP's. The price of SIP's that we've looked into ended up being about 28% more in terms of construction costs than our standard building details. However, if you can incorporate the exterior and interior finishes with the SIP's, I think it makes it more competitive in its pricing because I'm not adding finish work labor and materials into its bid.

**A:** With SIP's for me however, my major concern is where you run utilities? How do you get electrical and plumbing into the walls?

**A:** They have chases built into the panels where you would run wiring, and we would send them prints and when they manufacture them, the window openings, door openings, and chases would be in the panels when they send them to us.

**A:** [We] worked for a company that built equipment and communications enclosures that utilized a cam lock system like those used for refrigerators. What they would do is they would preassemble them in the factory and made sure that everything fit, but then they dismantled it, shipped it on pallets and reassembled it onsite. Although they didn't do a lot of work like that, it worked well. In one building in Boston, they did an enclosure where the panels were sent to the roof through the elevator. They completed it in about 72 hours.

**A:** We have a building in the works that will be shipped on a flatbed instead of a chassis similar to what you are specifying here. It will not have the axles on it.

**A:** They have what they call a double drop deck for the trucks now that can get you a higher ceiling height if it can sit on a bed instead of its own chassis. But then you are limited to length, even though you end up getting additional height.

**A:** Generally with something like that your



modules can be 40' or 50' maximum.

**A:** I'm familiar with the helical foundation system, but is this adjustable pedestal foundation a product that is available? Is this a steel platform system that the SIP's rest on?

**Q:** Yes.

**A:** I thought this was kind of neat with the electrical conduits, the ducts, and the sprinkler pipes are positioned at the seam instead of trying to hide everything. Again, if there was a way to figure out how to do more work in the factory, regardless if it is 8' x 24' sections, and coming up with some method of transporting would be a time saver. Though I don't know how long it would take them to assemble flat packs onsite. I think that ultimately we would be able to hold tolerances better in the factory than they would be able to onsite.

## APPENDIX B.2: TRANSCRIPT B

Company B Meeting Transcript

No. of Stakeholders: 1

Type of Interview: Face-to-face

**A:** First, I'd like to give you a little background about [our company] because we are quite unique in that when you think of modular you typically think of an assembly line type process and working within what they call a "controlled environment" with factory workers. [We] build outside and we use a process that we call our "build together process." If a customer has a two story building, we will build it outside so that a customer can come and walk through their building. So, what we have done is we have put the modular industry as close to site built construction as this industry can get. And we do that by using local subtrades rather than factory workers, and we work off of architect's construction drawings instead of generating drawings for [unskilled (but trained) production workers]. With us using subtrades, we have a higher level of quality with a higher level of skill because we have trained subcontractors doing the construction. It just gets us that much closer to being a site-built building making us far above others in the way that we approach a project. Basically, when a project leaves our facility, it's anywhere from 85% to 90% complete, whereas on an assembly line process, they may only be able to get to 75% to 80% complete.

**Q:** *Why do you think it is important to get your process as close to a stick built process as*

*possible?*

**A:** Quality and faster speed to completion. If the customer is looking at modular building, unfortunately they are usually looking for something less expensive, [but they are primarily] looking for speed. They want to get a building, and they want to get in there fast; whether it be from a revenue generating standpoint or an employee displacement standpoint. And so, by us building it together here, we can pretest everything so when it gets to the site, it goes together much much faster than in an assembly line because in an assembly line type process you are moving a unit down a line and it doesn't get tested with the element behind it until it is put together onsite. In our eyes, that is too late. What if it gets to the site and those modules don't match up? Typically that is what happens – floors don't line up, walls don't line up, mechanical systems don't line up, etc. – because you are relying on trained factory workers using tape measurers to measure a point on any given module and you have to account for the error in both the different tape measures and in the different workers – six different employees taking six different measurements and they can be up to 1" different over a length of 20' for example. So, we want to build a building with a higher level of quality to it. We also take that stance that if you walk into [one of our buildings], if you can tell that it is a modular building we feel as if we have failed. We don't want you to walk into one of our buildings and

see "mate line" seams or see where the ceiling, the floor, or the walls went together. We don't want any of that. Where typically if you walk around a modular building you will see hints of where those "mate line" seams are. For us that is not acceptable.

**Q:** *Why is that? Do clients come to you for a modular building, and they don't want it to look modular?*

**A:** Part of it is that we want to rise above the industry. We want to provide our customers with a more permanent service (we build more permanent type buildings than temporary). We want our customers to get a very different service because typically and unfortunately the term "modular" has a very negative connotation to some people. People think about trailers, and that unfortunately is a very difficult stigma for the industry to get past with the customer. Again, we are helping the industry to elevate it past that stigma. We don't even like to use the term "modular;" we like to call our type of construction "offsite construction." We try to avoid the term "modular" simply because it has that bad stigma to it. When we work with a customer, we want them to come away with a very good experience with the modular industry so that if they have other needs in the future, they come back to the industry, or at least are willing to revisit it. That just makes us a little bit different than most in the industry.

**Q:** *Can you describe your process for me?*

**A:** We start with building a steel structure (what we call a steel cube) in the plant: including a steel chasis, decking, temporary steel columns, and a roof structure. Then we transport it outside across the street and set it on a temporary foundation getting everything blocked, leveled, and tied together. And then, when the steel structure is completely erected and set in place, we then come back and pour the concrete floor as a monolithic slab. Now that that structure is outside, the mechanical systems can be installed, the steel studding can start, etc. Basically, from that point onward we build just like site built construction, where we have subtrades coming into the building site to build the building. In one case for example, this was a two story structure going to Massachusetts in which we had to match the existing building at three different elevations for floor access or access into the new structure. That is why you see here spacer beams that are bringing the level up to the current level of the existing building's floor elevation onsite (interstitial space). Following the standard construction methods and techniques that they would use in a site built construction process, we build the outside first with interior mechanicals being installed at the same time because there is nothing that will hurt them weather-wise. Then as we process through, you can see how the "mate lines" handle an electrical junction line with an electrical whip; the ducts are similarly held back for a piece to be installed at the "mate line" onsite. Then we try to get the insulation in, the sheathing board on, and the outside completely weathered in before we start in earnest on the interior construction.

The reason in this project, for example, that they went modular was because of the site was complicated, and at the site they couldn't get materials and workers in because it was boxed in. [It's a] three story mechanical structure, a 6 story hospital, a 4 story psychiatric ward, and a two story connector link between the two facilities creating a courtyard as the only access in which we could lift and drop the modules in order to get them in and slip underneath of the hospital because its third floor jutted out 18 inches. This was a very difficult site and that was the reason they went modular for the project. It was a very industrial looking building simply because it was inside of a courtyard, and with it being at Cambridge, MA, they put these decorative panels with ivy planted at its base for future growth. This was built with a total of 14 modules – 7 on the first floor, and 7 on the second floor – and on the interior as you look down the corridor which passes through all 7 modules, you cannot tell where the "mate lines" are located. So, we are one of the extremes, and there are a lot of factories that build in a similar process and more at a middle ground between an assembly line process and our own built together process.

**Q:** *From the perspective of the fabrication process, while breaking a design up into a larger quantity of smaller components will provide a greater degree of flexibility in the application of a system of interchangeable parts, does this pose problems for the manufacturers because of the precision required for the increased number of joints or of the coordination at the point of assembly onsite.*

**A:** When people are looking to this industry, it is all about speed to completion, so the less work you have to do onsite the better off you are in meeting deadlines set. The green features prominent in this process include less site disruption, less security required onsite for protection from material theft and hazardous materials laying around (you don't have a fenced in area because you bring the modules in, and you get it finished shortly thereafter so the construction equipment is gone very soon), better safety at the jobsite, and presumably less material waste and a better chance at recycling materials. In your process you want to address those attribute associated with the modular industry. So by increasing the amount of onsite construction, you take away some of the opportunities for us to take advantage of those benefits.

**Q:** *In your process are you eliminating the need for the added step of creating a set of shop drawings?*

**A:** What I'm saying is that in our process, the architect is the one that takes the drawings to a level of detail where we can build straight from them. All that I am going to do is supplement the architect's drawings with my structural steel cube drawings since I am building and designing the structural element of the building; so I will have to give that to the architect. Other than that, he maintains ownership of his drawings and he maintains ownership of his commission. That is one challenge that we face when working with architects. When you talk to architects about modular construction,

they feel that they lose some of their ability to earn a living. For an assembly line type of construction, for example, he doesn't have to do a lot of drawings, and that is what he is mainly getting paid for. With our type of construction, we're telling them to do the full set of drawings and go through your process with the customer, and we'll build from your drawings. So he maintains his viability and his contribution to the process. So again, there are these extremes that exist in this industry from assembly line type of production to our type of production. Though on our type of construction, we do have architects that from time to time say they will put together the basic type of design but they want us to take the drawings into a construction detail level. That is really dependent on what the architect and his firm wants to contribute to the project in the end. Though that does typically depend on how important the project is to them.

**Q:** *When we talk about the market's perception towards modular construction, are you primarily using different terminology to disassociate yourselves with lower quality buildings that are historically seen in the industry?*

**A:** You just have to be careful with the term "modular." Because there is a preconceived notion of what modular is for some individuals. It is difficult for the customer to get past that sometimes. We've walked into school boards looking for alternative methods to get a school built, and once we had an architect present a project to the schools where he did everything he could to avoid the term "modular." And he

succeeded without bringing the term up once, until a member of the school board labeled it a modular building to which he had no choice but to agree with, and ultimately that killed the project (although it was a very viable alternative to their needs). Once everyone on the board had this preconceived notion that they were going to get trailers, the project got shot down. That is where you have to be cautious, and in part is why some of us in this industry are trying to get away from that word – we use "offsite construction" or some other terminology instead. So in a presentation, it is important that the end customer understands what it is you are trying to offer to them. So it is tough to get past that marketing point. For your project, I'm looking at the word "pods," which may have a different connotation in the eyes of the end client as opposed to the word "modular." It may have a different meaning to some people as well; for me a "pod" is more of a packaged unit and the word "modular" doesn't come to mind right away. You just have to find the right words. And there are not a set of standard terms required or consistently used throughout the industry, so you do have to be creative in how you sell the project as an alternative building process.

**Q:** *Among the perceived barriers and constraints to design innovation in modular construction, transportation limitations rank among the highest challenge for architects as well as the inflexibility of the construction process and the amount of pre-planning required. Would you agree with these findings?*

**A:** Transportation limitations is more critical for those that work with an assembly line process because we're transporting our modules on a low-back tractor trailer whereas an assembly line typically has an integral hitch and axels. When it has a hitches and axels like that it is in essence a vehicle and falls under the motor vehicle laws. So they are a lot more restricted than me because I sit on a flat-bed tractor trailer and therefore I'm considered "freight." So, if I get higher, or wider, or longer, I can simply pay more money and have it transported as a "super load." In contrast, if they get higher, or wider, or longer, they can't ship their modules (though they can get up to some pretty large sizes before that will happen). So they are a lot more restricted in their means and methods of transportation than I am. With your design, you would pretty much fall under this type of scenario of being "freight," so you are not going to have the type of restrictions that will have with a "mobile modular unit." So you wouldn't face the same type of restrictions as an assembly line type process. So that is a good attribute.

**Q:** *The program of the building for this case study is a relocatable educational facility, and one of the reasons this program was selected was because of the tight time frame typically required for the competition of a unit.*

**A:** I sat on a local school board building and property committee where I live, and with the schools' planning process their scheduling don't really occur until May or June. So they do not know what their projected student population is going to be until late in the year, while still

needing facilities in September. That is where the portable classrooms have played an important part in helping the schools adjust to the student population at the various schools. So it is a planning problem on the schools' side, though that is why the modular industry comes in as a viable solution for that problem. As we talked about earlier, both site restrictions and time limitations are largely where we get the majority of our workload. When you get into an urban area like Baltimore, Richmond, or Alexandria, for example, streets are tight and congested and onsite construction in those areas is extremely difficult because you don't have what is called the "lay-down area" where a general contractor can come in and place materials. He doesn't have room for the workers to show up onsite and park their vehicles, etc. There are a lot of problems associated with urban type areas that onsite construction has difficulty overcoming in their building process, and we'd like to think that modular construction becomes the best solution for those type of areas.

**Q:** *Whereby breaking this design into a larger number of parts, the number of joints is increased, and therefore the precision required for fitting and assembly is expected to be very high in the end product coming from the factory. Is this idea of a prolonged fabrication process feasible from an economic and fabrication standpoint where a considerably smaller volume of components would be produced in later years after a high volume of parts have already been fabricated in the early life of a project?*

**A:** We have a sustainable classroom on our property; our other offices have school districts that will order 700 portable classrooms at a time in any one given year. They use those so much more to adjust their student population than [we do here]. They see these facilities as a more permanent type solution to a problem, whereas down here it's strictly regarded as a temporary situation. With this type of design, you are offering flexibility. These really could become whatever the school district would need them for – classroom space, office space, study space, etc. These adaptable pods offer more flexibility to school districts than just classroom space. We've tried to market our sustainable, non-combustible classrooms for years, and it just won't fly in the region that we sell. It does come down to dollars and cents, and I think that with the way the school system is set up, there are too many different entities involved so that they tend to overlook the overall, big picture (they look at the temporary classrooms as a quick fix). They are not looking to the possibility that you can take this portable classroom and move it from one school to the other. While there are some school districts that do do that (Montgomery County in Maryland, for example, is great at doing that). But, they often don't look at that fact that these could be used for something else, and I simply don't understand that myself.

**Q:** *Can this be attributed to a poor explanation of the product or of poor marketing? Or is it simply attributed to initial building cost restrictions?*

**A:** It is a difficult question to answer. School districts have historically had the same attitude, but I'd like to think that they would look at the overall big picture including adaptability and re-use. As you have illustrated here, you could have an entire school built out of this type of system that as needs change, you could bring in a different pod, make a different attachment, or swap out something. It just makes perfect sense to us as builders, but I don't know how you would get that across to the general public. So it is not a barrier from a production stand point, but it is a difficult process to market and to educate the general public in. It is an educational process, and I do think that things are slowly changing. For instance, we just did a school project in Alexandria, and they've embraced the modular classroom concept. We built a wing for one of their schools this past summer, and it was built with the understanding that they could potentially build a second story with the intention that if they built a new school and they were going to tear the old one down where this wing was currently located, they can take it (the modular portion) to a new building site and go from there. Once you have one school district trying something like that, you have other school districts around it that acknowledge it as a viable process. It just takes one to get the ball rolling, and then potentially others will invest in the idea. The modular building industry has been around since about 1947, and we are just now in 2011 getting people to understand that there is a viable resource/alternative to site built construction. It just takes time.

**Q:** *Is there going to be an issue with*

*craftsmanship if the components are broken down into smaller parts?*

**A:** Yes, but again you are offering a great deal of alternatives so it may be necessary. The customer will know initially what is needed/wanted. So, you're still going to be able to deliver a faster speed to completion project to the customer even though it may arrive in more pieces. As long as it is all engineered, and as long as it is all delivered at the same time, and there is a speed to completion process that will enable you to finish that building out quickly, it is still a viable option as compared to site built construction. You always want to compare this to site built construction; you don't necessarily want to compare modular methodology to modular methodology. This is because you want to sell the advantages of modular processes to site built construction because that is who your real competition is. If they were to do this exact same process onsite, it may have taken them 2 or 3 times longer. So, if you are able to cut that time table down 30% or even 50%, you are still the advantage. That is what the modular industry is all about – speed to completion. So, although there are many pieces, it is a viable alternative to site built construction. Remember, they only have from when school lets out in mid June to when they start up again in the end of August or beginning of September to complete their requirements/accomplish that student population shift, and find means and methods to get them housed. As long as your completion can fit in that two month window, it is a viable solution.

**Q:** *The SIP's for this project utilize an integrated cam lock system commonly used today in industrial freezers.*

**A:** When I was working for a company down in Baltimore, 1973 to 1980, I built overseas camps using the cam lock system. So this took me back, and I thought that that system was dead. That to me, though, is a very good solution. I used that in a lot of overseas camps, and that cam lock system was so quick and easy.

**Q:** *Does it require too much precision to be feasible?*

**A:** Yes, it probably does require a high level of precision, but manufacturing has come a long ways since the days that I used it in the 70's. As you've probably already seen, everything is set up in jigs, so while they don't build like us and maybe don't get the precision that we would get, the 1/2 inch tolerance that you have allowed in the drawings is more than sufficient. I would think that you can easily manage to build these parts within a 1/4 inch to 3/8 inch tolerance. So, I don't think the cam lock system is a draw-back with regards to accuracy. In today's manufacturing process with jigs and the way things are set up, accuracy is very good today versus where it was 30 years ago. So I don't see it as a problem.

**Q:** *Would you outsource the SIP's fabrication to specialized manufacturers?*

**A:** Yes, but if you have a manufacturer that would concentrate on this type of construction

– a blend between panelized and modular – in an assembly line process, you could easily integrate the different materials into that process already set up with its jigs. You would simply bring over that foaming machine that puts in the soy-based material and injects it into the wall panel system. So, in actuality, the adaptability of the manufacturer would be fairly simple. Even for me it would be simple; if I needed to, I could set up jigs to build up panelized wall sections. I don't necessarily need to subcontract it out to a SIP panel manufacturer. They might be better at it, and they might be less expensive, but it does depend on the manufacturer whether or not you go outside to get the work done and how aggressive they want to be; whether or not they would want to keep it in house or whether they would want to sub it out. There are alternatives.

**Q:** *So are you willing to adjust your process accordingly for any new project coming in?*

**A:** Yes, if we were to bring the SIP's manufacturing, for example, internal, that will give us more control over the quality and whatever adjustments that need to be made to the elements or design itself. If I were to subcontract these SIP panels out to someone else, I will lose control. If I keep it in house, I maintain control over quality, accuracy, etc., and it will ultimately add to the resume of my plant's capabilities. So, if someone else came to me asking about construction with SIP's, I now have the means and the methods to do that work. We are always looking here at new alternative building methods and that is why we

are so open her to adjustments in our process. If construction techniques are out there that we can bring to our production process, I need to understand them so I can remain competitive within in my own industry. [Our company has been in business] for 35 years, though we have been here for about 8 and 1/2 years. We are very open minded.

**Q:** *Does the volume of the work factor into whether or not you are willing to alter your process?*

**A:** With a smaller order, the price would have the tendency to be a little bit higher than if it were a volume piece or order, but that is with any production facility. Volume is key, no matter what you are building. Again, it is not as important to us as it would be in an assembly line type manufacturer. I don't think that with this project it would be difficult to revisit our process for a smaller order. And since we have the jig set up, the accuracy should still be there.

**Q:** *Are CAM technologies and an automated process be incorporated into the production of components?*

**A:** For automation, the biggest problem would be volume. Volume is required to automate a plant because you are putting an outlay of cash to develop systems, methods, jigs, and whatever else it takes to build the end product. So to start you would need volume, but you would also need to maintain that volume over the years because of the large outlay. But if you

have a manufacturing facility that has diversity, you can tuck that away for a little while and hope that the business comes back while you concentrate on something else. That is why we are so interested in different avenues or adventures in modular construction because if we can build something only once, we at least have a project to look at and say that we are good at that type of construction should it come back in a future project. But for start up, automation is volume driven.

**Q:** *To what extent is BIM being used in your manufacturing process?*

**A:** The problem right now with BIM (having just come from a seminar), is that it is over sold and overhyped. Architects are not willing to share the drawings. What is important with BIM is the information system. If you have a customer that doesn't buy into that information part of Revit, there is no sense in using Revit because you can draw a line in 3D AutoCAD just as well. But if you have a customer that is willing to invest into what BIM can give in terms of that information, then that is when it really needs to be utilized. If the customer is going to take the Revit drawings and use the information in that drawing to give him immediate access to what kind of air filter the mechanical systems take, and he stocks that part, inventories it, and places it somewhere, I think BIM is being well utilized. I'll give you a good example: Penn State is all BIM now. With what used to take a maintenance guy an hour and a half to replace an air filter, he can instead go to this room where all this information is stored locally and

pull up what building he is looking at: it tells him what the air conditioning unit is, it tells him what the filter is, it tells him where it is stocked, and he goes and gets it and replaces it now half the time it used to. There is a customer who understands that they can cut costs because they have a maintenance man whose work was cut in half – they're only paying him 45 minutes to replace an air filter versus an hour and a half. That is where BIM becomes important, but if you don't have that customer buying into those benefits, there is no sense in using Revit. The other problem though is sharing. Revit was developed over the concept that an architect would do the drawings and share that with the trades. They are not doing that because lawyers are telling them that it creates a liability, so architects are not willing to share Revit. That is one of the biggest problems we are having here. We bought Revit and we are training in Revit, but we can't get anyone to share it with us. The architects are not willing to share their drawings with us because of liability issues – they are afraid that if we make a change to the drawings and it becomes a problem onsite and adds costs, then they are automatically sued. So, Revit is not a good solution to a problem as of yet. Revit should be used as a tool and it should be shared. Architects are not giving up that tool to allow the trades to do their job. Revit right now is a failure to us, and most of the architects that we are talking to are abandoning it and going back to AutoCAD. It is a shame though because it is a fantastic tool, but it will fall by the wayside if lawyers and litigation are involved. It will however take intelligent end consumers of a building to understand what

BIM can offer to them – in managing systems, in maintenance, future additions, renovations, etc. Until the customer becomes educated and can understand its future applications, it will not be forced enough to the point where it forces the architect to share that information with the trades in an attempt to bring all that information back to the customer for their use in the future. BIM's use must be customer driven, not architect driven because the architect is worried about liability issues.

**Q:** *Are there instances however where BIM is required?*

**A:** The last three projects we have worked on, we were told that Revit would be required, but it never happened. But this modular type system in your case study project is a perfect example as to what Revit is made for. You would have these models of these different parts and you could plug and play with the different options within that full building model. All the resources are already in place for BIM integration into our process and all the technology is available. But it just hasn't taken off yet. We spent a lot of money on Revit, so we will keep pushing to use it and learn it better.

**Q:** *What problems are more prevalent in large scale complexes versus a single classroom?*

**A:** The biggest difference is price. Volume gives you economy and scale gives you purchasing power – the more you buy the more you can get a discount, or you reach a level of discount with some suppliers. For mass production

volume is again the key because it is going to drive down your costs, you'll get economies of scale out of your workers, and your labor starts to get faster with the 10th or 30th iteration because the process is fully understood (while the 2nd iteration might take as long as the 1st). So, volume will help your costs be lower as seen by any assembly line production facility (Ford's Model T for example). Initial startup costs might be high, but you would spread that over the volume that you anticipate getting.

**Q:** *What problems are prevalent in the interface between architects and manufacturers?*

**A:** Not too much really. The caveat is that we try to get involved in design process as early as possible so that when it comes time for production, you don't have the problems. With our type of process, if we are able to sit down with the architect, after maybe he has already sat down with the customer and come up with a preliminary design for the building. [This way we can] make sure that where the split lines are laid out from module to module is accurate, and [make sure] that where the structural steel needs to go is well defined. The earlier the manufacturer can be brought into the process, the better. We can assure that the blend between the architectural design and the production process fits together well with one another. If Revit can be utilized and drawings can be shared, it will ultimately make it that much better.

**Q:** *What problems are prevalent at the interface between offsite construction and onsite*

*construction?*

**A:** [We] send a project manager to the site to make sure that everything that is being done onsite matches our requirements so that the buildings land properly. With this project across the street, the foundation is under construction right now; it sits on steel plates so that when our building sets on top, it is welded in places. The steel plates were put in the wrong direction. So, in our type of construction, we find that there is a lot of effort required to coordinate between the building and the site. That is where a lot of problems do come in in this industry which can give the industry a bad name because most of the manufacturers don't have the capabilities or the willpower to send people to the site. It takes a lot of time, effort, and money to do that. Because we want a successful project, we make that effort, and most times we find that we are glad that we took that step. When you have units arriving to the site just hours apart and requiring to be set in place, it requires a lot of coordination with site people. The chances of a successful project is so much higher if you have someone onsite than if you didn't have someone onsite. So it is important to us to have a project coordinator that manages the site effort in our building.

**Q:** *What is the role of a general contractor onsite?*

**A:** The purpose of the general contractor is to do all of the site prep, running of utilities, foundation, and installation of the final assembly. He ultimately bears the responsibility for the



end result. But again, he may not be familiar with the process. So it is important to get him involved as soon as possible as well. We invite the general contractors to come here to see how our buildings are built. But even then, there is no guarantee that he has an intimacy with how we build. So that is why we send a project manager who is intimate with our process, who understands the project, who has an understanding of the finer details of the modules, and who is looking beyond not just the construction of the project here but what is it going to take onsite to make the project a success. While the general contractor is ultimately responsible, he is not going to know and understand everything. So a key element for us is making sure that someone from our facility goes to the site to verify that everything is as it is supposed to be. We have our own project managers in-house who manage the project from our drafting stage, through the purchasing of materials, the coordination of the subtrades, etc. (basically the whole project while it is at our plant and who we will eventually send to the site).

**Q:** *Are there problems that commonly arise during the transport of modules?*

**A:** No, though the potential for damage is always present. I have seen modules lay on their sides and on their roofs on the way to a site. Because you cannot make much progress [when that happens], there just really is no good solution because you will need that module. That possibility does always exist, but it is a rarity that that would happen. And generally,

that type of situation is usually an Act of God – gust of wind, etc. Tree-lined streets are the biggest problem, because you are hauling a load down the road on a truck, and inevitably this little branch will put a big scrape down the side of a unit or of a building. That is where you are going to get most of your damage in transport. Not much you can other than going in and measuring a route and cut branches off of trees or cut trees down – though sometimes you face challenges in getting that done as well if it is a private property or a city. You can route around bridges (low hanging wire and traffic signals will not cause damage). Trees are the biggest problem that this industry has in getting a unit to the site – though it is still a rarity – other than transportation restrictions.

**Q:** *What type of finish are best saved for onsite construction, or do you like to have the majority of your finish work done in the factory?*

**A:** A lot of our buildings go in without floor finishes because it sometimes doesn't make sense to put them in ahead of time because of the amount of traffic a construction trade that is going to be in the building will put on the floor surfaces. This building across the street is a government building that has an 80-20 rule (requiring the building only being capable of being disturbed by onsite work by 20%). So when that building arrives onsite, it has to be 80% complete. So we cannot afford to put the floor finishes onsite – it has to be installed here. The floor tile is generally the last thing we do before we exit the building onsite. When you have a finished product, it

takes a knowledge and a skill on the part of the people onsite to understand the type of building or product that they are getting. We had a building down in Virginia, for example, that had a very expensive metal architectural panel on the exterior. Whether our buildings have an exterior finish or not, we always wrap the building in plastic to give it an added layer of protection and to keep it from getting during transport, etc. So this building with the metal architectural panels was wrapped in plastic, and a worker ended up destroying a panel with his utility knife while removing the plastic. Had he known or had he been educated to know what he was receiving, he probably wouldn't have taken a knife to the plastic and at least taken more care into the removal of the plastic. Again, because he wasn't understanding what he was getting, he created a very costly problem. So you have the separation between what the general contractor and his people know and what you know as the manufacturer – there is a disconnect there at times. There are some manufacturers however that will handle all of the work. In-state, we will build, deliver, and set the building and finally finish it because we are licensed to do all of that work. Outside of the state, I am not licensed to do all of that work. But you have some manufacturers that will follow a project form the beginning to the end. They minimize that risk. So again, there are different manufacturers with different capabilities.

**Q:** *To what extent are you finding resistance from architects taking a modular approach to their designs?*

**A:** Almost all of our marketing dollars are spent educating architects. We do what are called “lunch-and-learns” where we are given an hour to do a presentation with a free lunch in hopes that they understand what you do after you leave. The biggest thing that we find is that not a lot of architects know that [our system] system exists (this “build-together process”). The type of finishes and the level of completion that we can get to with our process can surprise them too. But once they understand it, and can find value in it, then it becomes a no brainer. We have [a local architect] that has embraced our technique so much that they are out selling it to school districts. So at one end of the spectrum we have architects that have embraced the modular industry and know what we are capable of doing in our process and is out there promoting it. [At the other end of the spectrum], architects that associate a negative connotation still with modular construction find no value in it and associate it with cheap, low-quality, and less-durable buildings. Once they have that mindset, it is difficult to sell modular construction to them. So, at times it can be difficult to get architects past what they perceive modular construction to be despite what we have showed them. Once they can find a value in it, they then are willing to embrace it. With schools, usually it isn't architect that are afraid to go modular, but their budget doesn't permit it. The infrastructure that schools have is crumbling beneath them because they do not have the budget to fix or maintain their buildings. We have a building out here that Canada has embraced in the last 10 years that just hasn't caught on in the US – it is mold resistant, non-

combustible, energy efficient, etc. But we can't sell it in the US because it is twice the cost of a wood temporary classroom at \$45 per square foot. It has been discouraging that we haven't been able to get this building sold. Right now they just don't have the budgets for this type of building. Though Alexandria's school system, for example, does have the money and are a growing school district and have ultimately found the value in going modular with their buildings. I think that having that one school district in a major metropolitan school district area like that will help surrounding districts to see the advantages in having these higher quality buildings. Because I think that these buildings offer other long-term/big-picture advantages that the \$45 per square foot buildings don't. There are so many advantages in a modular type system that you can't get out of a site built system. The school in Alexandria can literally move an entire wing of their building to another school site. You can't do that with a site-built building. So while these advantages that we try to sell center around portability and speed, ultimately cost savings can also be achieved in a modular type building. If you can take a whole section of a building from a school that doesn't need it anymore, and move it to a school that does, the cost savings to the taxpayer is tremendous because you normally couldn't do anything other than tear down an old antiquated building. There really are endless possibilities available for the application of sections that can however be moved and re-used and made adaptable. So while it may be the building of the future, it takes an educated consumer to understand that and

recognize the possibilities. Most people are however driven by immediate costs, that they lose track of the big picture in terms of future costs for new additions. In Europe, modular construction is so widely accepted now that they cost more than site-built buildings because of its adaptive re-use, its availability, and its speed to completion. They recognize that there is a price to be paid for the benefits of modular construction themselves, while everyone in the US still equates modular with cheap buildings (no one recognizes the added value). In Europe they are so much further ahead of us in accepting modular buildings. I think that what will help though is the green codes and LEED. Those types of awarding systems I think will help bring modular to the forefront. Though it will still take some time. For example, back in the 70's when we had a gasoline and oil crisis, solar panels were regarded as an alternative to oil, but it never took off. It is acceptable today though because it is considered the right thing to do – green, sustainable and re-usable. You were lucky if you could sell a solar panel in the '70's, because people thought they looked ugly on top of houses. But today everywhere you drive you will see solar panels on top of houses.

**Q:** *Do you do a lot of the design work for your own projects?*

**A:** We have the capabilities to do both, but because of the way that we build, we are more focused on allowing the architect to do more design work.

**Q:** *Are you ever faced with the task of having to turn a building into a modular building, designing the way the building would have to be broken up in order to make it feasible in modular construction?*

**A:** [One school], for example, was a pie-shaped building with a portico in the front. When we worked with the architect, he came to [us] and proposed that we do only a little portion in the front of the building. But by the time we were finished with the architect, we were building the majority of the building. The architect and his customer came up with the design, and what we did was divided it up into a series of modules – breaking the sections of the building into smaller prefabricated parts that would be erected onsite. So we ended up building pie-shaped modules for the project. But we let the architect and his customer do all of the design work. There are projects, however, where the customer comes to us not knowing what he wants, and wants us to handle the project's design entirely. So we do have the capabilities to do both, but again because an assembly line has a certain mold that the building has to fit in, most of their buildings are square and box-like. They have so many more restrictions put on them (they can't build a two-story building in their plant) than I do. The more custom their buildings get, the slower their line gets – volume is much more important for them than it is for me. Each factory has its advantages and its disadvantages. They may in fact be more adept at building your design than we may be because they have an assembly line already set up that can be easily be set up. They have

jigs already set up to build the walls. They may have the advantage over us then because I would have to gear and tool up in order to take on something new. That doesn't mean that I couldn't do it, but it does mean more time and more money for me to do that than it would be for them.

**Q:** *Do you have any additional comments on the design of the case study project itself?*

**A:** For instance, with your wall panels; for us, that could be something that we could potentially sub out. We find another manufacturing plant that is maybe used to doing SIP panels and they will do those type of panels for us. The bad side of that is that we will lose control, but after we jig up and tool up and everything else in house to gain control, it might cost us up to three times as much to do that than if we had subbed it out to a place that already does that type of construction. You have to look at what is for the good of the project. Typically the good of the project is to build it competitively so that you get the orders to continue this type of design. Then, in that case, we would have to sub this work out. The pod construction would be perfect for an assembly line type process. Our [other] facilities are looking into building bathroom pods. In hospitals and motels where you have repetitive style bathrooms, firms that specialize in bathroom pods can slip in their pods into these buildings because of their repetitiveness. That is a European idea that is now being embraced as a feasible business model. Similarly, in cruise ships, all of the cabins are modular. They aren't built onsite,

they are built offsite and brought to the ships themselves. So these pods do lend themselves to an assembly line type process because it is already being done. But when you get into the main body of your design, while it is basically made up of components, the basic structure is perfect for our type of construction. So if I were building this frame in our factory, and I had a side assembly line for these pods, then I can bring all of these pieces together and build it here as a complete building before it even gets to the site. So the possibility exists that I can ship this unit here, for instance, with the pods already attached which would decrease the amount of labor onsite thereby increasing our speed to completion. So, because this design is being transported on a flat-bed tractor trailer, the whole bottom assembly can be shipped as a super load or a wide load, minimizing site work. So there are a lot of different methods that can handle this project differently in the factory. The project does bring together a lot of diverse methods of modular construction into one application. This could be completely built in a single factory, but it does depend on how much control or how much the manufacturer wants to take on, and on whether or not they subtrade the SIP panels out to a SIP manufacturer which will depend on if you can get it to a cost point to market it appropriately. There is nothing in your design that I see as a manufacturer that would create any type of manufacturing problems. As with anything, you just have to develop the system – the means and the methods to develop and fabricate it. What you can't fabricate in house, you will need to find someone who does fabricate it.

**Q:** *Can you talk about potential difficulties with the demountable foundation system and the challenges at the coordination level between offsite component construction and onsite pre-work?*

**A:** There are systems already that work like this. A lot of the mobile modular builders utilize it because those are temporary-type situations. A more permanent building would require a more permanent foundation. There are a lot of foundation systems that are geared towards this industry. So, again, your ideas here are doable, and there are probably already systems that exist that you will not have to go and reinvent the wheel for. So I feel like everything is out there already that can make this design happen. There is nothing in the design that really scares me from a manufacturing standpoint.

**Q:** *But you have stated that you would recommend that larger modules are formed offsite (panels and pods combined) instead of having them shipped apart on a flat-back?*

**A:** You would try to reduce the amount of onsite labor as much as possible, but again if your customer comes to you with an order for your system, he's already going to know what he wants. So you'll be able to incorporate that into the end product before you deliver it anyway. You're always going to be able to reduce your onsite costs and your onsite requirements simply because a customer is not likely going come to you requesting a set of panels (one Panel A, one Panel B, one Roof C, and one

floor A). They are going to be ordering a complete building from you. So it is not going to be arriving onsite in pieces and parts that they have to put together.

**Q:** *So, as an architect, you are not going to want to give away control of the design of the floor plan by just handing a kit of parts that the customer can play with and create his own building with an online model.*

**A:** Well, this can get the client close to understanding the type of building that they want. So they could order what they want, but they're not quite there without the architect. That's why the architect and the manufacturer would come in and show them what they have conceived, and offer them what is really possible for the type of building that they want. Which again falls back to that assembly line type methodology where this lends itself to; allowing the consumer to pick and choose, versus a process where the architect is starting from scratch.

**Q:** *With your process, you call for full scale mock-ups and inspection of the architect and the client offsite for everything including the mechanical, electrical, and plumbing systems?*

**A:** Yes.

**Q:** *I also don't have a problem with a modular-type aesthetic with the module and seams completely visible.*

**A:** We do have projects where that is acceptable. For example, we worked on a daycare with an architect that is pro-modular. He wants the building to look modular – exposed steel and ductwork inside, etc. But that requires us to be highly quality driven and a general pain, but it is going to be an award winning project when it is all done and it will be a nice project to have on our resume. So because he wants it to look modular, he will have taken his design to a very high level that most manufacturers cannot achieve. But it is that challenge of getting the modular industry beyond that perceived conception of a trailer. So it is good to have projects like that which can help to change that perception among architects and among customers. Eventually as time goes on and more and more of these type of projects are out there, people will associate the term modular with these type of buildings that are architecturally design driven, high-end quality, exposed infrastructure and superstructure, etc. That is one of the things that will bring the level of this industry up again.

**Q:** *While the building is feasible from a design standpoint at the scale of the single classroom, start-up costs will essentially force the issue for a larger application right?*

**A:** Yeah, initially volume is key. But once you are past that, whether you build a single classroom or an entire school, the start-up doesn't factor into the cost, but square footage does, [providing discounts from a supplier] because of volume. Though at the larger scale, coordination becomes the major concern from

the manufacturers standpoint. With the larger school that you have drawn, even the larger bathroom and stair core can be broken up in a modular fashion. The elevator, though they do have some that can be contained in a modular fashion, will likely be built onsite. These type of areas we do modular quite frequently, but where you run into the biggest problems is where you have a large expanse like a cafeteria, an auditorium, a gymnasium, or a large mechanical room. Those are typically site built. That is where you will end up having a blend between onsite construction and the rest of the building – the offices, the classrooms, etc., which are is all done in a modular fashion. Then it comes down to coordination. In one project, for example, they built the stair towers onsite and when we went out to take measurements to verify, the floor elevation was off by an inch and that had to be torn down and rebuilt. [Our slogan] is “no limits, only possibilities.”

## APPENDIX B.3: TRANSCRIPT C

Company C Meeting Transcript

No. of Stakeholders: 1

Type of Interview: Phone Interview

**Q:** *What was your role at the company?*

**A:** I was the Director of Architecture and Engineering, which meant that I had to define how all the architects and engineers had to operate (including the structural, mechanical, and electrical people [in the company]). So I had to define the way in which the company interacted with the outside world (the architects, the structural engineer, etc.), how we licensed and legalized buildings, what we documented, and what our role was in the greater construction process. The reason why I was in that position was because of my BIM background, working on high end projects using BIM coming from the architectural world. I've done a lot of large, multi-disciplined, multi-story projects which needed that level of coordination available within the BIM world, while my project managers [had primarily only] dealt with it in the more traditional world of 2-D construction documents. The CEO of the company (who had a manufacturing background and he basically wanted to manufacture buildings) wanted to push, very aggressively, into the world of automation and the world of BIM, bridging that gap between the architectural and the manufacturing communities.

**Q:** *So were you largely responsible for creating the shop drawings?*

**A:** Exactly, and there was a lot of cross training involved in the process. For example, even though my architects weren't mechanical engineers, it was often that the same person was doing electrical and architecture. There were specialists within the department, however; there was a guy who basically knew the MEP stuff, and he would bleed into the architectural role, and vice versa. I knew SolidWorks and Dassault stuff in general, having used it in other projects going into the firm, which reinforced my bridging role. The sheet metal engineers were doing their work in SolidWorks,, and the architectural people were in Revit, and the models were typically put together in Navisworks for the final, end of the line product.

**Q:** *You've mentioned the concept of a paperless production process. What made that possible?*

**A:** Not just in the architecture and construction industry, but in the automobile industry as well, the piece of paper with the numbers on it are currently the only documents that legally stand when you go to court in front of a judge. There is no real precedent for the BIM model being a legally accountable entity. The challenge to getting to that place, where the BIM model is the legal thing, is the fact that it is still quite far off. Even Ford, who are among the most advanced car companies in terms of engineering output and research and development, still has to make 2-D shop

drawings for legal accountability. It's partly because those numbers that you put in the dimensions are not just considered information, they are historically considered demands to the person building it. It is not just "I wonder how much that measures." It's actually "this has to be this dimension," and "this has to be that dimension." And the work that can exist in the BIM model is not graphically explicit, or it is not explicit at all as to what dimension the thing that you care about. You can put annotations, or you can overlay dimensions within the model, but it won't be the thing that stands up in court. And, as you are probably aware of, so many projects do go through the courts at some point, and there are various levels of anger throughout the proceedings. So, the ability to get rid of shop drawings and to communicate in a BIM model, is not so much about communicating to the instruction on how to build it. What is more significant is the legalistic approval procedure of the modular manufacturer. The manufacturer has to have the approval of the architect on record, and they approve it against those numbers in the 2-D world. The examples that we have, I explained in my talk about the mechanical scenario, where the mechanical guy did not complete the drawings post-coordination. So our department, with experienced mechanical engineers on our team, took up the slack because we were the ones building it. And we kind of legalized it ourselves so to speak. It was kind of vulnerable, but it was nothing compared to the vulnerability of a building with bad mechanicals not coordinated

properly. So total design-build outfits have that ability to push paperless a bit more, because they legalize in-house. But it is unusual. The client usually has their own mechanical, their own structural, etc., or they want it to go out to bid with another mechanical firm. And that cross company legally has to communicate through that 2-D interface in the premise that the we might go to court in front of a judge.

**Q:** *Why is it necessary to have that shop drawing set to be produced as a supplement to the architectural set of construction documents?*

**A:** It is a good question. In terms of AIA procedure, the construction document is the product of the architect, and verbally and legalistically it is the coordinated set of all the trades come together. It describes the design intent of not just the project, but how all of the trades operate together. What the shop drawings are doing is something different. It is the isolated subcontractor who does their part – which can be as minor or as major as whatever the project dictates. It is basically saying ‘this is what I’m going to do, and I’m not going to veer from it, and this is how it fits into your construction documents set.’ So then the architect has to approve their commands, and then they can legally do it. It is also a financial check because the subcontractors will be ordering the materials based on the quantities and information indicated on the shop drawings that they have submitted. So if the subcontractor says “I need 30 tons of steel,” and they are only building a beam across two columns, there is a red flag and there is accountability in the paper

work documenting it. So the process can be horrifically inefficient, and every architect that you talk to will have a story either how work froze or how inaccurate shop drawings were compared to the architectural set released, but in terms of the world of construction management (in which everyone has to play the game, really), there is a logic to it. But it is not the most efficient. There are ways around it, but that is the prescribed way. The way around it does involve a lot of dialogue, and everyone being involved early on. [We] always had to do a design-build contract for a number of reasons. One of them was that the document set that we had to work with had to comply with government requirements. But then there is another release of what is called “bridging documents,” which make the construction documents conform to a modular manufacturer’s system. So it is part of that playing the game process, which will sacrifice lots of trees.

**Q:** *Can you go over some of the benefits of the design-build contract? Is it primarily used when architects aren’t designing a project for modular construction, and it needs to be redesigned to be able to work as a modular project?*

**A:** Yeah, it is a bit of that, but there are a few factors and I’ll go over it. So we had a preferred vender system; I guess you could call it a favorite architect, that we liked working with. And unfortunately that system didn’t always hold up all that well, because the architects had to get on board with the client, or we had

to get on board with the architect. And usually the client will say “well we want this architect,” or “we want it to go through a competitive bidding process.” And it’s true that we really needed to be on board from day one, not even giving the architect a head start; they needed to be in the room. Because their first questions are “how do we work with you,” “what’s your system,” and “how many architects can we put on this project if you need an architect designing with us in parallel.” There are so many questions that no one can take one step before the other. Often our clients were very eager to do modular. We were starting from nothing with the client requiring us to educate them, and they were eager to learn what was involved. When we brought the numbers back [to the client], with the calculations of how much everything is going to cost, there was either a dialogue or else they loved it and we all went ahead. The design-build scenario is something that a lot of architects are quite scared of because they are concerned about the lack of control they have over the project and how the building will turn out. Some clients are nervous about the competitive bidding process and how it is reduced, but what happens in the modular world when you go through the design-build process is that you package your bid for a government job comprised of three separate bids: an architect, a construction manager, and a modular manufacturer (which might sometimes be the same, we were also the construction manager on several projects). And you would go up against another team of an architect, a construction manager, and a modular manufacturer. This broad package of

a team is the direction in which the industry is headed in a broader context, where an architect doesn't just have to submit their design, they have to submit a whole cost analysis package with the construction manager and the whole project is chosen together with the team intact. When clients want to come to us and say that "I have my architect and he is going to have his construction manager, so I don't want to pay your architect to double up on construction documents," we couldn't do that. That was a client that did need educating on exactly why the architectural system fails at the modular level because what we do really crosses into the level of industrial production. Construction documents are inadequate for making a modular building, and the architect's training doesn't usually go anywhere near the modular industry. If you move on like this you really lose the advantage of modular construction which is a gain in time and money which is a direct result of the shorter amount of time needed to make a building (otherwise the cost comes out roughly equal to conventional construction). So that is why pretty much every modular manufacturer that you will speak to has to go through the design-build process because they have a pre-engineered system. They can't just make a general construction document set that gets sent out to the wind and hopefully someone will bid it. When some projects came in in that fashion, where a construction documents set would land on my desk, I would just look at it and I couldn't do it because it was another modular manufacturer's system. And it wasn't just that I didn't want to bid it because they had obviously been speaking to another modular

manufacturer behind closed doors; it was just that their system was their system and it was engineered to have UL ratings associated with it, etc. You couldn't just tweak it, you're instead talking about the whole redesign of the factory layout and stuff.

**Q:** *What are some of these questions that arise in a design charrette when the architect, the engineer, and the building manufacturer get together?*

**A:** It depends on how educated the architect is and how familiar the modular manufacturer is with the architecture world. There are a few modular manufacturers that have an architecture department in-house [like us], and there are also a lot of manufacturers that rely on the architect solely for the skeleton stuff which is more engineering. As a summary I would say that it is basic stuff like "well, what do you do," that architects ask manufacturers because architects also think that they know how to do it already. Now the education from the manufacturer to the architect is all about saying what they can and cannot do. They determine materials, and they can tell the architect where they can make the building thinner or narrower, and what you can't do like touching the structural elements, etc. So it is kind of like defining the variables and the absolutes of the structural system. And the fire ratings and tolerances are the main issues that I can attribute to being the first part of those meetings. Fire ratings are tricky in the modular world because [detailing] is complex in the modular world. It involves the inspection

processes interlinked with the design and the production which really impacts the project schedules. Tolerance, because it is something that never enters the architectural discussion at all. Even before you get to the screws and bolts level, the idea that you can't have whole dimensions all over the plan and not have anywhere where you don't have any give in it, allowing for things that people don't think about (like glue thicknesses, or the screw head). The architects don't necessarily have to deal with it directly, they just have to be aware that material dimensions aren't what they actually think that they are. So, I gave the example in my talk about [a module width of] just over 8', and there is a 5' hole and a 3' hole together across that width. Including the widths of all the walls that they had specified, the walls fall off of the edge of the module because the glue laminate is 1/16", and the grout is between 1/4" and 1/8" (and you are lucky if you get grout thickness in the architectural plan), and all those measurements add up to a problem if you are not thinking in a manufacturing mindset with that tolerance. So at that point, after the initial architectural meeting, that is the most general that I can get because beyond that the discussion gets more specific as any architect can produce any left-field comment that I wouldn't be prepared for. Like the other day, I was in a meeting, and the architect said that "all modular buildings look like an orthopedics' shoes, how can I make sure my design doesn't look like that?" I wasn't really prepared for modular precedents with design awards and how to design elegant systems and stuff like that. So, because the discussion went there, and you want the project, you try



to assure them that all you are providing is a system and a way of building. The outcome of the orthopedics' shoe is up to them to decide.

**Q:** *After that initial coordination meeting, how intense is the coordination with the manufacturer throughout the rest of the design process?*

**A:** It depends on the overall schedule. Sometimes they are very intensive, and our team will have to work full-time on it (maybe even in the architect's office, literally sitting in the same room as the architect). For quite a few projects, we developed what we called the "war room," where that project had its own dedicated room and everyone who worked on it was in that room no matter what company you worked for. That is the expensive way of doing it though, because it takes a dedicated staff and partitioned servers for developing that project. But usually you want kind of a back-and-forth fairly consistent throughout because it is not the traditional design-bid-build construction process. The pace is more consistent and the deliverables are a lot more evenly spread out. I would say that a minimum once-a-week meeting is necessary. It's not always about deliverables either, because often it is ongoing communication. I would say to the architects that we have to ease off of the deliverables mindset, and imagine that if I walked behind your desk at any time, don't be afraid that there is something wrong with the work and instead keep fixing it on a live basis, and nothing is too outrageous to ask. There was an architect who we worked for

[that needed us] to work alongside them very closely for a package and a bid, and they did a fantastic job of studying and understanding our system including the capabilities, the dimensions, and all of the parts and the pieces. By that point we really felt that they had a full understanding up through the part of the process that normally can be an assessable point where we can give our opinions. And they had gotten the perfect utopian dimensions taking into account the shipping route, the module sizes were not too wide, and [it was] slightly narrower than we had initially asked because it passes through certain states with more strict limitations. And we were amazed that that level of coordination went so well. But then the partner [of the architectural firm] wanted a material that was a very traditional, heavyweight material – like a composite stone – and suddenly it put the project into a totally different arena where we couldn't do it in the factory because the modules were going to be too heavy. So the choice then was to either do it onsite for many times the price, or they had to change the façade to a lightweight material (which the partners at an architectural firm do not want to be told), or if they wanted to keep that material [and still build it in the factory], the added weight would cause the dimensions of the modules to get much smaller. So, if you can imagine changing the modules to a smaller size because of the impact the weight had on their transportable size, you ended up with a new design completely. If the process [wasn't live like that] (and fortunately we were able to catch it a day or two after the request went out and it didn't end up scrapping the project), we

wouldn't have caught the effect that the change the architect wanted to make on the material selection. So it is a condition where everyone has to be in each other's faces constantly no matter how uncomfortable it is because it is a different process than what most people are used to dealing with in building construction.

**Q:** *Where could the education for architects improve in modular construction?*

**A:** It's a funny question actually. It really depends on how much the architect (me, for example, I'm an architect, and I worked for [this manufacturer], though I'm back in the architecture world now) wants to take it on. Some architects really like to be integral with the modular manufacturer, and be a part of their marketing. We want the opportunity to show the architects our capabilities and say "this is what we can do and this is how the architecture will integrate into that process." So that architect will require very little education on the next project they work with us on because they already know it all. Some modular manufacturers don't even want to work with new architects; they like their certain set of architects. So, it is a choice that can be determined by many of the parties involved: the modular manufacturer and the architect (as to how open they want to be and how they want to structure their outreach, if it is a system where any architect can come and work with them and any design can be modified). There are prefab guides out there, but you couldn't really run a project off of them because each modular manufacturer has a system, and they are very

precious about that system. Part of the issue with the modular manufacturing system is that the system is so critical, but it is also only talked about and discussed behind a closed door with partners of the firm together saying that they would like to do the project. It is a tricky hurdle for the industry because designs do get stolen, and architectural comments shared. There are systems and details that have a lot of research and development into them, but cannot be released to the broad publishing world, saying that “I would like to educate the world in a really broad sweep to eliminate a lot of that preliminary work.” Unfortunately, a lot of that preliminary work is done behind closed doors, and confidentiality agreements are made on those topics. It is all part of their sales courtship.

**Q:** *Can you explain the third-party approval system that you would have to go through for buildings at [your company]?*

**A:** This is one of the things that you have to educate architects about. We use [a third-party code researcher and inspector], and they were a company that was allowed to inspect and license modular building. They do the inspections inside the factory. What happens normally on the building site is that when the plumbing is done, or any licensed trade is done, their work is inspected and approved. Only when inspections are passed, can all the companies get paid and everyone can move on. Then the last trade to come in is the drywall, who seals up the wall. So, your argument as to what work has been completed

with accuracy is basically enclosed within the drywall finish, and you don’t want to pull all of that work down to prove that the work has been done. And furthermore, all of the trades are in the factory, and you can’t just pull the trades onto the site because they are working on bids and managing new projects in the factory. So what happens is that early on in the project (during the design), you will be allowed to get periodic inspections, or sometimes continuous inspections if you are an experienced modular manufacturer [with those capabilities] – though you generally want to avoid at all costs the creation of a design or a scenario that will require continuous inspections. A guy will basically come to the factory, look at the work and put a stamp on the module when it goes out the door, and that stamp has to be on a pre-approved area of the module so that they can find it (it’s clearly recognized). And, under state law, that will stand as the official approval for all of the trades that worked on the module, at least for the modular part because in the field there are connections that have a separate inspections process (though that is the conventional part of the construction process). The significance of that inspection process means that when the module leaves the factory, you [as the manufacturer] are really done with the job. It’s complete by then, and if there is anything that the architect doesn’t like after that, it’s too late. They need to catch anything in the factory. The architect cannot tweak and poke the design when it has left the factory. It can’t be changed then, its wrapped and sealed, and once its unwrapped, the client then owns it because you are entering an area

that has already been inspected and approved. On some projects, like communication shells or something standard, that inspector can also be the approver of the shop drawings – the person who stamps the drawings [in place of an architect or engineer].

**Q:** *In the project that you were able to go with a paperless production process, why wasn’t the mechanical engineer held accountable for the quality of the BIM model?*

**A:** It goes back to the fact that the drawings are the contractual entity. So, in theory, once you’ve made that 2-D drawing for the construction set, you’ve complied in getting that building legalized. However, you may have heard of the E202 [Building Information Modeling Protocol Exhibit] document from the AIA, where they try to set the standards for the level of development for the model itself. But at the time the contracts were written [for this project], the standards really weren’t that high for the actual model. So, while the mechanical guy had met the contractual obligations for his part, he kind of was held accountable (and that is why he even agreed to legalize the building based on our 3-D shop model) because there was a part of his contract that included coordination. So you could say that his thing worked, but that was before everyone [so to speak] had thrown all of their parts over the fence including the rest of the construction documents. What we ultimately agreed upon was that he forfeited the hours that he was going to get paid for hours for the coordination part of the contract. I think I’m confident in

saying that the mechanical engineering sector of the industry is about the furthest behind in BIM development. When they are forced into BIM, with their arms twisted, they are usually the ones that raise the additional fee flag. And many clients, unfortunately, are not willing to pay for this. This is unfortunate because what BIM does is force additional coordination in the early part of the project, with the extra effort going to the front and you not being able to just pocket that coordination money. So the mechanical engineer in this instance did not get that extra fee for learning BIM in 3-D. While the project was constructed in Revit, when the model came in the information was put in the floor or in the ceiling, but it wasn't drawn properly in 3-D space (for example, the pipes didn't go underneath and over each other, etc.). It was like a cheating 2-1/2-D. So they did comply with their contract. But a lot of people don't have a good working BIM contract, which requires an understanding of the product that you can get from a BIM project, and would require you to build into it the hours that you will need for coordination. In most firms, the difference is very little (a BIM project contract versus a traditional 2-D CAD contract), and if anything it is cheaper in the long run if you do a thorough and succinct additional procedure for [3-D BIM models]. And while it should come out less, so many firms have a business model based on the bare minimum of legalizing and immediately finishing their work on the project. You can't really compare the BIM setup against the bare minimum "winging it in the field," so to speak, procedure (and a frightening amount of construction is done through the "winging

it" and poor CAD drawings scenario) because what ultimately makes BIM cheaper is its removal of the "winging it" factor.

**Q:** *What propelled [your company] in to integrating BIM into the production process?*

**A:** With any architectural firm or [modular manufacturer] who has to go to BIM, the main factor that I would consider in all of the companies that I have been a manager, is the confidence and the assurance in the decision making of the guy at the top saying "we are going into BIM." There will always be a healthy amount of skepticism towards anything new that disrupts workflows causing your staff to learn new things. So, an educated CEO, or person at the top, will really help move things along. If the staff understands that the leadership is leading them in that direction and they can't get around that, then they will have to learn it. That psychological aspect is actually one of the challenges to the integration of BIM. [The reason why we] implemented it so early on was because it was a well-researched decision. A lot of the people at [our company] were from a very pure manufacturing background, and were horrified at the inefficiency of the architectural process. That is actually also how Revit got its start. The people who wrote Pro/Engineering (Pro/E), which is an engineering and manufacturing software, started Revit out of a disbelief in how architects work, and that very simple manufacturing program grew into Revit. [We] initially abandoned 2-D CAD-based working back in 2004 or 2005. SolidWorks was already being used for bent-metal panel

making, specifically the parts that required machine communication and preparation. So, it wasn't unfamiliar territory to go into the high-end BIM procedures. And I think that a lot of the manufacturers who you talked to who were cautious about it are not the manufacturers who make the actual parts of the building like the studs. Those that do already have to work in a very high level of design and digital preparation. So it wasn't that hard for [us] I would say because we were already making so much of the building and were at the heart of the manufacturing procedure, which was more complex than most architectural digital procedures (working in 2-D space). The challenge for [us] was the integration of the manufacturing demands with the architectural process.

**Q:** *And you were making metal studs with the CNC press correct?*

**A:** Yes, but not always. We did buy studs. There is a modular manufacturer out there that makes their studs. They don't do metal panels [like we do], but they do make their own studs. The metal panels that we used the CNC press was done more for complex projects, specifically areas of the project that needed intense mechanical systems integration (like the bathroom pods, and the communication shelter, etc., that have tons of mechanical equipment going through holes). The clients usually loved it because when you have that complex interaction of mechanical parts, you have to put loads of metal backers on the studs when you screw through the drywall. So by

the time you're done with putting all of those backers in, you've got a very shocking looking metal panel system anyway. So the speed and increased time of building them in the factory made it worth-while.

**Q:** *Have you run into any resistance of architects to using BIM because of liability concerns?*

**A:** Yes, and it was usually in the beginning of the project, when the architect is reluctant to let us in under the hood when they don't know us. It's not a case of the architect being stingy. It is the architect's insurance for their practice, which is based on their employees being the ones doing the model. So it is not just a case of being uptight, it is hard legalistically. So when we worked with the architect directly, we couldn't really be the ones clicking because we weren't the ones working for the company. But we could look in it and we could do a lot of direct commanding as to what needed to be done and what needed to be worked on. The architects really weren't used to the Revit or BIM specialization being at a much higher level on the manufacturing side, so there was that initial surprise when they realized that they were the ones playing catch-up. Though it works in reverse also, as the architects don't want the manufacturers to mess up their model. So it is hard to create that scenario of the digital utopia where everyone is working in the same file. I don't think that that really exists yet. When I was a BIM manager at large architecture firms. I normally am using a live model, and I don't send it every 10 minutes to some manufacturer, and they work on it

and throw it back after they have worked on it, and someone somewhere coordinates all of this back and forth. They may want that ideologically, where that one live model is the thing that everyone is working on, but the only one that can do that is either a very large design-build outfit, and everything is in-house, or they are exaggerating and it hasn't worked like that completely (with only limited success). That is far from the industry norm. To achieve that, you have to be on the industry's cutting edge, and Autodesk hasn't actually perfected the system yet. So it is not normal.

**Q:** *What is the greatest idea to the concept of mass customization – an automated process creating custom fabrications?*

**A:** I gave an example in my talk about the state of mass customization. The machinery can be very advanced, like the robots that you saw in the talk. And they are very capable of complex movements. And the software being designed for what is being built is also very advanced, but there is a disconnect there. It is like owning an apartment in Central Park South (one of the richest areas in the US), and you have a Ferrari in New Jersey, but you take a scooter to get to it. There is a huge disconnect between the software [we use to design] the thing (whatever it is, be it Revit or SolidWorks, or Grasshopper which is the ultimate mass customization tool), and the software that are involved in programming the robots, which are usually quite disappointing. Now I haven't seen the full range, and there might be some out there, but whenever you are buying this

advanced machinery you have to balance the machinery with what the software is as well. Like the Ring of Fire – the automated steel cutting machine – was the worst scenario, which was like an Excel chart calculator really. So with the robots, even if you wanted to move the steel by 1/8 of an inch, or something like that which is only a fraction, you had to write a whole new program for software with checks to verify the coding. So you had to write a new program anytime there was something different, and to the architectural world 1/8 of an inch is not really different. There is a difference in thinking, with something like a mirror command which would seem simple to the architect. It is a different X, Y, and Z coordinates set. Or, for example, in the bathroom pod, having a hot and a cold plumbing line, you can't just flip it and expect it to work; it needs to be a whole new design. So there isn't a place where there is true mass customization within the software of the machining, and that is the real challenge. For example, a lot of how Grasshopper is being applied is typically fancy lobby walls, and you follow the commands down to the person building it. You still would talk to the carpenter and have that interaction with the human, telling him that he is putting a thousand different things into these walls. So, even if you design it in a simplified way, there are still a thousand different things that you are putting into that wall. And there is a very complex system of command that you have to draw up. So, the actual software is a big hurdle that we couldn't even overcome. We just used the robots for the aggressively repetitious work, and I mean repetitious in the manufacturing sense, not the

architectural sense, where it is absolutely the same thing done without a change.

**Q:** *Which was primarily small task work?*

**A:** Yes, and it wasn't the architect's fault, it's just a matter of fact that there are things that will skew the repetition of parts, even if you are trying very hard to keep the repetition. So, like that example of mirroring, the hot and cold must stay the same, you can't just flip it. Architects are generally ahead in mass customization specifically in formulating custom tweaking. But it is still a challenge, and ultimately in the construction industry you have a lot of guys on the site who need specified commands. And you still have the reality of tons and tons of pieces whether they are the same or not. The more those pieces are differentiated, the slower the workflow goes. Unless you are at the level, like the car industry, where you are fully automating all the way (including assembly and not just making the parts). The scenario exists where the more repetition you have, the better use you can make out of the machines for the cost. This forcing of repetition does lead to some unfortunate architecture, and that is the reason why cheap, nasty buildings look so repetitious.

## APPENDIX B.4: TRANSCRIPT D

Company D Meeting Transcript  
No. of Stakeholders: 1  
Type of Interview: Phone Interview

**Q:** *What is your role at [the company]?*

**A:** I am the Director of Marketing and Business Development. We are not a huge company, so in business development I tend to work with new clients outside of the modular industry. Like some of our military clients, and some of the bigger healthcare clients that we build products for. So I am typically in the initial meetings with the design team. One of the barriers is that often times a modular manufacturer is brought in after the project has been designed for conventional construction, and they are looking at modular construction because of timeline or budgetary concerns. If the building has been designed for conventional construction, some re-design is going to have to happen. With the biggest custom projects that our company does, it goes well when we have been working with the client, the general contractor, and the architecture and engineering firm from the early planning stages.

**Q:** *Why is it important for the manufacturer to be involved in the early stages of design?*

**A:** The usual challenge is that there is a misperception by the owner of the building in many cases because modular construction often in the public's eye is equated with manufactured housing, or something like

that, where you are looking at inexpensive, economical, mass produced-type products and people aren't associating it with what we can provide. In a permanent modular building, the goal is that you don't even know that was prefabricated offsite. A lot of people just aren't aware of what the possibilities are, so when they are going to look at a modular manufacturing company, they have an expectation that they will see the budget drop 15%, for example. And this just is not the case always with modular construction. The timeline can be reduced by 25%, but the cost reduction isn't going to be that dramatic. So I think that there is sometimes a [misconception] on the part of a client. When we are working from the beginning, we can value engineer technical issues. Like for example, as a modular construction company, when we build something for the state we are going to get approval by submitting out production prints. And even though we don't have to submit the full set that we have in the shop, we will create a package for whatever that state's industrialized building group is. If we are working together from the start, we will coordinate with architect and tell them to do these particular drawings because we will already have to do these particular drawings. That way we are not duplicating scope of work. So we can coordinate to make things more effective, we can value engineer the dimensions of units, and give them references as to what can and can't be done and what the costs are, [all] because our company builds a lot of buildings that have 60' clear spans and

we know that we can purchase steel trusses of fixed lengths very economically. So if I were to value engineer a structure, I'd recommend using, for example, 12' wide by 60' long modules wherever possible to get the best value. So there are things like that that you can look at. What I liked about your project is that it does address the transportation restrictions. One of the things that I'd see when architects would send in a project that they've been working on for a client that they want pricing on from our company is that it turns out to be something that we can do, but it would be expensive. A client does not want to pay something like \$135 per square foot for modular construction. So we could do some value engineering by coming into the project early and reduce the projected costs. We can also avoid overlaps in the scope of work. And really often on a large project it is going to be a hybrid. For example, let's say we are doing a large permanent project, like a school building. We will have modular units comprising the classroom wings, often times we will panelize the roof over the entry, we have glass curtain walls that we'd install onsite, we have elevators and stairwells going up onsite, etc. So, there are a lot of things that we may be able to do easier than the onsite guys.

**Q:** *Can you define or expand on this concept of value engineering?*

**A:** With a project like yours, I think there is the opportunity to bring to the table some things like economies of scale because you are

working with a limited number of components. I have a customer, for example, that is similar (though the product is nothing like this), and what they do is they modify once-used shipping containers for use in military operations and urban training facilities. What we're working with is various configurations of 8' x 40' or 20' shipping containers that have different door and window assemblies cut and installed in the side. There is sheathing like galvanized steel, there are 48" interior partition assemblies, etc. So they are using a limited kit-of-parts that they are using to comprise the various buildings. Their business model is that they are going to shop hard for pricing on each of these assemblies, using the fact that there are a limited number of components that they are sourcing. They can volume purchase and drive down the per unit costs down. So I think that with the product that you have, because you are working with a limited number of components and the fact that the components are fairly interchangeable, you could use some of the economies of scale. The prices of a lot of sustainable materials, I think, also have been going down dramatically over the past 3 or 4 years. So in actuality the price of the project could go down in a couple of years to \$15 per square foot less than it is today in terms of material costs. The most complicated fabrication that you obviously have in there is the SIP's panels. You would have to source that carefully, working with an existing panel maker that would already be tooled up to do something like this.

**Q:** *For the project, the concept of the flat panels*

*shipped in a more compact configuration was designed to counter one of the problems of modular construction in wasted shipping space. Yet, the suggestion is still to ship larger modules to reduce onsite construction complexity. Which do you think is a more effective solution for shipment of this kit-of-parts system?*

**A:** Obviously there are pros and cons to each. You aren't going to spend much time onsite if it is a very finished component. The company that I work for is a little bit different. We do a lot of custom products where it (the part that we are making) is going to just be a component of a much larger building. We recently did an 80,000 square foot secure information facility out on the east coast for the military, and all we shipped was structural shells – no exterior or interior finishes, no electrical, just conduit runs, etc. We just wanted to get [in that project] the envelope of the building in place and out of the weather [and they could] finish everything else onsite. So our scope of work differs quite a bit. We have a project out in Chicago, which is like an 8-story building and we are prefabricating about 300 restroom components (that is a 98% site-built building). So, our company has less bias in terms of requiring you to build a 3-dimensional module. The pros to shipping a 3-dimensional module are obviously the fact that you aren't going to spend much time onsite, and you can manage some of the efficiencies [of the modular process] in the factory. Our factory, for example, is in a fairly rural area and the labor rates are therefore fairly low in our factory. We can ship into Detroit or

Chicago where comparatively our rates 1/3 less than what construction wages would be there. So there could be some advantages there. But then again when we had some work in Chile (after the earthquake hit) for a huge mining company that had money and needed temporary shelters, the building cost \$750,00 to build and it would have cost \$750,000 to transport it. So, instead, a system like yours with a flat pack is more economical to be exported overseas. Everything that you have here can be shipped in standard iso-shipping containers, which would be stacked 9 courses high on an ocean freight vessel. That is something that I like about this system. You could use one central manufacturer and even transport them by rail or some other more inexpensive modes of transport. But again, your idea is something that is new to modular manufacturers, and the guys that sit next to me (one having worked in the industry for 30 years and another for 27) are very conservative and there is a sometimes a lack of innovation.

**Q:** *How many projects have you done overseas?*

**A:** The project in Chile didn't happen because of the transportation costs. We have done projects in Iraq, Afghanistan, Guam, Germany, and a new one in South Korea which is a skiff building for secure information. We do a lot of telecommunication shelters for the military that will be computerized and are in custom-built iso-containers. Last year we did about 130 of them for Afghanistan. With those though, we were just the manufacturer, and we weren't

responsible for transportation once they left the factory.

**Q:** *Do you typically have a standing relationship with the general contractors doing the onsite work, or is that a problem, in terms of the quality of the work that they are doing?*

**A:** We are a whole-sale manufacturer so we are going to sell through one of our distributors. Although in the last 8 or 9 years we've tried to diversify [our clientele]. So, the people that we would consider to be distributors are technically general contractors. There are some [modular manufacturers] who will do direct work including installation and the site work. They would be considered the general contractors. We've done that a couple of times when we do projects locally, but we don't tend to do much work at all in-state though. From our plant [here], we are usually shipping to one of the urban areas in the Midwest (Chicago, Detroit, Cleveland, Cincinnati, Indianapolis) or to the Mid-Atlantic states (Boston, New York, Washington, DC). Or else we are doing military contracts. We don't do a lot in the more rural areas just because construction costs are very low there. And unless you have a pressing time constraint, which I can make a case for the client that saving time is saving money, [the benefits aren't marketable to rural areas]. To give you an example, we fabricate radio-therapy buildings for a company, and they have a proprietary steel vault system that we fabricate for them. It is relocatable and the vault system is comprised of 4 prefabricated units, and the whole structure is relocated every

30 days. Hospitals will rent this radio therapy clinic for them when they are upgrading their own equipment, because people cannot pause their treatment while the hospital is down for upgrades because they would lose all of those patients since they would just go somewhere else. So basically one month with the radio-therapy equipment on a fully booked schedule, and that \$700,000 of revenue to the hospital, [which is equivalent to] the typical cost of a piece of radio equipment. So, if I can show them that we will be open 3 months earlier than a conventionally built building, it is easy to equate time savings would equal \$1.1 million dollars of extra revenue to the hospital. So, like in this case, it can sometime be really easy to make the case that with the time savings, the reduced disruption of the site, and things like that can override the fact that the costs are similar. Sometimes in the Midwest, we would be even more expensive than conventional construction. As I mentioned in the email, with a 3-dimensional modular unit you are going to inherently have redundant material in there. For example, at the seam line, you are going to have two trusses where the two units are coming together. And it's probably unavoidable because each of the 3-dimensional modules needs to be structurally distinct, causing material redundancies. And even though I work for a modular manufacturer, I did go to architecture school at Ball State for a couple of years, which make me more likely to be open to some alternative approaches. With your scheme, you've reduced that material redundancy, you've addressed some transportation issues (particularly some of

the export issues), etc. And it wouldn't be that tough of a system to build a business model around I don't think. Because working with components like that you could even use a leasing building model. There you would address some of the issues like that which [a client of ours is using]. For example, they are doing business in many different states and the buildings may or may not be compliant in each of those different states. When we built a leased fleet product for them, we would need to comply with 26 different states so that they could use them interchangeably. So they'll end up with units that accommodate a 60 psi snow load, and they have copper pipe plumbing to comply with Massachusetts, etc. Whereas, on the flipside, with this panelized system, I think that you can make it comply with nearly any state's construction code, assuming that the components are interchangeable, making the system truly reconfigurable. We sell modular construction as being flexible, and as being adaptable. But I see with a panelized system where you can interchange components to comprise different units as the next step in being able to make it adaptable because you really could comprise an unlimited number of structures out of that same library of components.

**Q:** *What about your ability to take a design for a different modular manufacturer's systems and adapting that to work with your system? How difficult is that?*

**A:** To some extent that is a game that people will play, to specify things that work best with



their system. There are some guys in Canada, Eastern Canada, and the Northeast that only do steel frame construction with poured concrete floors. And then there are a lot of manufacturers that don't do any steel, or pour concrete. So certainly you can reduce your competition if you get the architect to specify everything in steel. So, there is some of that, and if you do a lot of steel buildings, you can purchase steel at lower costs than a manufacturer that does less. So, it's one of those cases where maybe they could do something more efficiently or cost effectively if they specify things a different way. With this system here, and the way that our company is set up now, we'd end up subcontracting a lot of the subassemblies. [That] is something that we do a lot of because [we are in a fairly] reasonably sized city, and we have a lot of defense contractors and healthcare contractors that we could potentially subcontract these items to. And whether that would be a cost effective way to do it or not remains to be seen. So we wouldn't be set up quite properly with the appropriate technology to do something like this panel that you have designed. But we have done some custom panels before that we've subbed to people. Like a project that we did a couple of years ago that was panels that were removeable and reconfigurable and could slide into place. That was a case again where the buildings cost was more than what they thought that they could get in the market. The majority of the work that we do in the education sector is work for charter schools because the public school districts don't have a lot of money. And I think that might tie into

poor public perception, where public projects that you hear about go poorly because of people who are not qualified [are doing] the work or bad work is done. It is a black eye to the industry.

**Q:** *What general design considerations need to be understood early in the process?*

**A:** What has always helped with us is when someone comes into the factory and sees the system and the way that we typically build things. At our factory [here], the steel frame is going to be integrated with the building. So, if an architect could understand the basic cross section of the building [things would go smoothly] because in a multi-story building you are going to have the case where you have two units stacking one on top of another to comprise the building, and roof system of the first floor module, and then the floor of second floor module (steel floor subsystem) sitting on top of each other. And that is not a way in which an architect would typically design a building. In this case, with a multi-story building over underground parking, the extra height of these systems stacked up on top of each other was going to take us over the height in which we got approval from the city to build. So I think to understand the cross section for the way that modular units work is important. This includes having some idea of how they are going to be installed onsite. [One solution I've seen an architect make proposed that] when the craned units were set, one would be able to slide over another. And hypothetically, that would work on paper, but when you're at

the construction site and you have a 60' long modular unit dangling by crane straps 100' above the ground, it is easier said than done to have that unit slide partially under the other unit without damaging them in some fashion. I also think it is important to understand some of the dimensional restrictions which is something that you did a good job in addressing with this system. You can do a 16' wide module unit, but if you are shipping it to the East Coast, that would be very expensive to do. So I think that things like that are important: understanding the dimensional restrictions, understanding the cross section of the typical modular building, and understanding the installation procedure. And something else that is important, which is when we look at a hybrid between work that is going to be done at the site by the general contractor and work that is going to be done at the factory, there are some things that I think we can do really cost effectively in the factory versus doing it onsite – like ceramic tile in a restroom, is something that we install really frequently in the factory, and we can do that cost effectively. In classroom buildings it may make more sense to lay carpet tile when the building is at the site (particularly where the two units have been joined). That all goes back to the importance of value engineering at the beginning of the process. If we can understand those things with the architect from the beginning, then you're not going to run into the issues where we are going to run into conflicts with the height restrictions, because it is easier to address these type of things upfront rather than when you have 60% of it done.

**Q:** *How intense is the coordination with the architect after that initial coordination meeting?*

**A:** It is still important, and I think it's improved in the last several years due to some of the technology. Obviously we are working in BIM, the architect is working in BIM, and the client is now easily able to visualize things. This gives the client a good overview of the building because when working in modular construction you are compressing the timeline of the overall project. There isn't as much time to be doing things like change-orders because we are producing the building much more quickly. You have two phases of construction running concurrently [in modular buildings]: while the general contractor is building foundations, we are building the building. When he finishes with the foundation, we will start shipping modules to the site. So changing things mid-stream is more difficult. Some of those technologies like BIM allow a clearer picture of how all of these components are going to be working together. You can easily visualize the structure, you can see where the problems are going to be, and it is just overall fairly easy to collaborate using some of these technologies. So I think that that has improved things definitely.

**Q:** *Does BIM also aid in your inspections and your approvals?*

**A:** Yes it does, but rarely are the inspections and the approvals a problem because they are something that we deal with so frequently. I mean, our company does business in 48

states, so we are fairly used to some of these things. Customer approvals is something that we are always waiting on, because we are trying to run production every day. That is just a challenge that you will have to deal with. You try to give people a couple of weeks and get them the stuff quickly.

**Q:** *What is the challenge with fire ratings in the modular industry?*

**A:** It depends, but non-combustible construction is not an issue for us. We do a lot of steel [construction], and we do a lot of poured concrete, and it just isn't real problematic. There are some construction types that aren't going to work. The real restrictive fire [codes] in the city can be problematic, but I don't think it is something that cannot be addressed because in Europe and Asia you see some really large prefabricated projects being done. So I don't see it as an impossibility.

**Q:** *What about the issues with tolerances in the architectural drawings?*

**A:** We have worked completely from architect's drawings in the past. But our company is probably a bit unique to some extent. We did a seven building school campus, and the architect did all of the drawings for the project including the drawings that we submitted to the state for approval. If there is a good understanding of [modular construction], we don't even have to do the production drawings. It's not as if we don't want to keep that in our scope of work, but if the drawings are good, there is no reason

for our manufacturer not to be able to work off of them. The only issue might be that [the workers] are used to seeing it one way. For the customer that I mentioned to you earlier where we are building training facilities for the military, each of the fabricated components for their system we have SolidWorks files. And since we are assembling and installing these components in the shipping containers, we'll do the subcontracting for the items we won't do ourselves (or purchases like the specialized door handle they have specified), and we will do no drawings at all. I'd say that the first two weeks were challenging because their drawings are different than those that our drafting department would produce, but the problem only lasted a week or two once the people got acclimated to it. So that is not that concerning for me. But again, our company does more custom work rather than mass produced products where you are going to be working for a long time on very similar things. So that usually is not that big of a concern to us.

**Q:** *How often are you able to build off of a construction documents set from an architect?*

**A:** This project that we are doing right now is 534 shipping containers that are being modified, a seven building school kit, and a local dormitory were all built from the architect's drawings]. So just a few projects I would say we've worked from the drawings. In some of those cases they were firms that we have worked with in the past. We have [another] plant [that does a lot of work with an architect on healthcare projects, and they] have a really good understanding

of modular construction. So it is easier to work from their drawings because they have a strong grasp on what our process is like in the factory and what the installation process is like at the site. I think that the more that architects understand about why we want to do it a certain way the better. If you have so sort of an understanding about the process and the justifications as to why the modular manufacturer likes to do things a certain way, then I think that it simplifies the process. For instance, when we do slab-on-grade [work], we don't like to do anything longer than 40' because it's difficult to find a drop-deck that you ship the building on. So if you have floorless sections that are designed as 48' long, even though it is possible, it is going to be hard to source shipping for the building. So there are little technical issues, and I don't think that it's actually that difficult to design a modular building if you have some grasp of how the system works. I think the main issue is the differences in the way that manufacturers do things.

**Q:** *So are you saying that they need experience with you specifically or with modular construction in general?*

**A:** I wouldn't say that you would need specific experience with one manufacturer or the other. There are obviously going to be difference in the ways that manufacturers would prefer to do things, but I think if an architect has a good grasp on how the system works and why things would be sized the way they are.

**Q:** *So the main element is transportation dimensions that an architect needs to understand?*

**A:** Right, the cross section of the building also as I mentioned earlier. I've also talked to a lot of end customers and they feel that the architect has run the price of the building up on them. And really they are calling on us as a modular manufacturer because they feel that they could reduce the price. So that is another thing to always keep in mind. I talked to someone on Friday, and he needs four classrooms, and he hired an architect and he has them designed as Project Frog units which are a very sustainable panelized system but really pricey for the North Carolina market. So that is another thing to keep an eye on – the fact that you can't get out of the client's budget.

**Q:** *So you would almost be selling modular construction as a different product – comparable to site-built construction – in that you can provide a faster speed to completion and you can accommodate difficult site conditions?*

**A:** Yeah, and also the flexibility. We've done several classroom wings additions onto a school, and they can grow when they need to add more space by adding to modules. It can happen over summer recess so it won't disrupt classes. You have (something people aren't looking at right now) better life cycle costs as opposed to the initial costs. When you site build a building in masonry or concrete, you really have a capped solution there. With a modular or a panelized system like you have

in your packet, it can be scaled up over time fairly easily with minimal disruption. We could have a charter school building where they are expecting 50 kids in that year, and then they might be expecting 100 kids that next year, and what do they do? Do they rent storefront space for the first 10 years until they have a good grasp on their enrollment, or do they try to build initially a building that is going to have room for 500 kids (which is their eventual goal)? A prefabricated system [provides kids with a] sustainable, and healthy space from day one, [and that] could easily scale that building up or down based on actual demand. So to me, the ultimate sustainable building process adapts to the needs of the user over time. Which is something that is much easier to do with prefabricated construction and modular construction, and I think that it is an important thing that people overlook. For example, I'm at my in-laws house where the industry climate has really fallen off and the unemployment is high. So you have a bunch of vacant school buildings sitting here, whereas a couple hours to the left of here [the schools] are overcrowded, the student are crammed, and they [are using] portable classrooms. If you could shift that empty space from here to there, you would be able to solve a lot of problems and deliver much better education to the students. That's one of those things that I don't think people think about and it is hard to put a dollar value on it, so it is hard to sell that to people.

**Q:** *How are you selling that to your clients?*

**A:** Basically the way that I just sold it to you.

Some businesses will see value in that a lot. But you know that when a school is looking to lease a classroom, they are thinking that they will have this thing for two years, and they don't care what it is and they just want the cheapest option since it is a temporary solution. Still a lot of schools here in the Midwest don't even look at modular construction as a permanent solution. Most of the permanent buildings that we are doing are charter schools. And from what I've heard, they only pick modular construction because of some specific challenge. Like the first large project that I worked on when I started here 6 or 7 years ago, was a school in Detroit (a charter school, fairly new), they had money and financing, but they owned a piece of land with an old building on it. So, we demo'd the building the day that school got out, cleared the site, installed foundations, and we had the new building which was 58,000 square feet up in the Fall. And that is something that you couldn't have done with conventional construction. But often times when we get customers in like that because they are in a position where they couldn't do it any other way.

**Q:** *Are you showing precedents to potential clients show successful applications of modular construction?*

**A:** Right, and now we've built 4 permanent buildings for that particular chartered building in Detroit, but we would have never gotten in the door unless it was a project that they couldn't possibly do any other way. And some of that is based on awareness [as to what we do]. An architecture firm will probably know

every general contractor in that area – at least by reputation if they don't know them and haven't worked with them before. The modular manufacturer's website is about all they would see of us. Some of those are challenges for us, and we may just not be on people's radar. So for architects they'll think "maybe these modular manufacturers have a cool system," or they'll think "OK, I've worked with this guy on like 15 projects, so I know him and even though I know there might be some value to the system, I'm going to play it safe." So I think that that is one of the challenges. And we'll run into the problems with labor. The project in Chicago that I was talking about where we are doing the restrooms, the general contractor was having problems (and it was a big, long controversy) with the construction union there because they didn't want these prefab components brought in. The general contractor argued for them because [the modules] were basically just like a piece of equipment that they would pay us to hook up, and so there were just logistical challenges. I don't think that the modular system cannot be adaptable to any of the stuff that we build now. I don't think that there are any insurmountable challenges to working with architecture firms to do these kind of things. It's just public perception issues. It's a relatively new system that has been used much more the last several years than it has been in the past for more permanent things, but it seems like awareness amongst architects is increasing. So I'm relatively optimistic about the future, and there is also the sustainability aspect of the process itself. I think that studies have shown that it is a much more sustainable

process before you even get into specifications, systems, material selections, etc. The process itself is more sustainable than the conventional construction process, and obviously because of resource scarcity it is going to become more and more of a factor over the coming decades. It is kind of hard to put a price on sustainability, as usually we kind of talk about it as a tertiary benefit. It's not LEED certification where you'd have some sort of tax incentives. Though we have done a number of LEED Certified buildings people largely don't want to spend the money for that when it comes down to it.

**Q:** *Do you use simulation programs to try to put a dollar amount with the life cycle benefits of the product?*

**A:** Since we're doing a lot of military projects, the contract has in the past specified that a project had to be LEED Silver, and now it's gone to LEED Gold. So we have done a number of them, but usually that is going to be in the architect's scope of work. As a manufacturer, I'm LEED AP but I'm going to have very little to do with the submission. I'm going to write the justification for which typically the USGBC will award you the Innovation Credit for modular construction. We will also provide mill certificates on the steel we use showing its content, and we are going to provide information on the factory's recycling program. But most of the calculation side of things are going to be in the architect's scope of work. On LEED Certified projects, we are going to be looking to the A/E firm to do HVAC design and the modeling on. But we would do that on small projects that don't

involve the architect or that don't require LEED Certification.

**Q:** *Can you talk about your third party approval process?*

**A:** Yes, we use [a third-party inspection agency]. The process is different [at our other factory]. They don't use a third-party system, and instead get inspected by the Bureau of Labor and Industry. [Here], we can sometimes use the construction documents for the third-party approval, but it depends. Every state is different, and I would hate to have the job of the lady in our office that does approvals. We don't have to typically submit our full set of construction documents that go to the state building permits. We also don't have to submit our full set of production prints that we are generating in the plant, but I cannot say how much you need to submit for each state to get that approval. Some states turn it around in a week or two weeks and they will often times give you conditional approval to start building. And [they will] even send you back mark-ups. Some states are really good at working with the modular manufacturer, [and its important because] we have [work] scheduled to go online, and if the project doesn't go through we'd have people standing around waiting for something to do. So that is a concern for us as a manufacturer, but it is not so much a concern for our customer. It may become a concern for the architect if they are doing some portion of the drawings because we would be on the phone with them telling them what still needs to get wrapped up. In some of the states, if

they have some mark-ups on your plumbing design, they will give you conditional approval to start building up until the point where you have some red lines, and then you would have to wait for corrections to come in. So some states are better than others in terms of letting people continue work.

**Q:** *So do [third-party inspectors] check drawings and trade work once it has been done?*

**A:** Yeah, they do. They are there probably in the factory maybe 4 days a week, if not everyday. And then we obviously have in-house quality control that is doing inspections. And, depending on the project we may have an owner's representative inspecting the project as well. That is common on some of the restrictive military projects that you may have a government security officer serving as an owner's representative. So there are several tiers. I am confident saying that a lot more eyes have looked at every step of modular buildings than of conventional buildings.

**Q:** *Are you using BIM on all projects now?*

**A:** We draw almost every project in Revit nowadays. On some of the government projects it is now just a requirement so that you can work with everyone else on the project. I think that that really makes collaboration and the use of prefabricated components and modular units a lot easier [because it makes it possible for clients] to visualize in the design phase (which is when you want to be identifying the issues).

**Q:** *Have you run into any conditions where the architects are unwilling to share the BIM file with the manufacturer?*

**A:** We haven't, but I guess I could understand where there might be [a problem] with a proprietary product. Like that radio vault system that I was talking to you earlier about, that is our client's proprietary system and if we were ever in a system where we needed to share BIM models, I don't know if they would allow that or be happy about it at all. I see that it could be a problem, and it's not been a problem for us as of yet.

**Q:** *What contribution to the BIM model do you typically need to make?*

**A:** By the time that we are sharing models, usually it isn't a problem. In two weeks from now I'll be going to be working on the hospital [in Chicago], and once we've worked out what the architect (based on their client's requirements) decides that restroom component will look like, that's when we will start to model it out. But, I think that most of the time we try to get a clear picture of what [everyone's scope of work is]. So in that project we'll be doing the model for our portion, which is a tiny portion [compared to the whole]. It is just the prefabricated restroom that is going to go into the three hundred room hospital. So, we're going to model that, and they are going to use that within their larger building model. The main reason that they want it is to make it easier for everything to line up or to see how the [modules are] going to connect together between the prefab units

and the actual building itself. So it is not an issue that I've run into yet. We're not a huge company, and we don't have a huge drafting department, so we try to get a good idea of what we're drawing before we start investing people's time into it.

**Q:** *Do you use it on the factory floor as a supplemental drawing set to assist fabrication?*

**A:** They do not, no. And with some of that, I've been after them for years to bring the technology up to date out there. But it's not really a welcomed message with the way that the economy has been the last few years. They are usually looking at 2-D printouts out at the factory typically. In the steel fabrication shop they have some nicer equipment and they might be using some more advanced processes that they aren't using out on the typical assembly line.

**Q:** *Do you think a paperless production process is possible?*

**A:** Yes, at the company that I worked for prior to this one which was a residential modular manufacturer, our factory was brand new and it used technology that was much more advanced than that used in this factory. So there is room to automate the process even further.

**Q:** *Where can BIM improve from your standpoint?*

**A:** I do not know [anything] specific. When

we moved to Revit, we paid for someone to come over for about four weeks and we did training classes. So, the main complaints that I've heard have less to do with the software, and more to do with it being something new and people not understanding how to use it as well as they knew how to use AutoCAD. In the modular construction environment, you are always moving quickly and you have to keep production running, so you don't have a lot of time to sit and work out all of the functions of the program. You have to be turning drawings quickly. Our engineering department, since a large majority of the projects that we do are custom, they are going to end up doing a lot of drawings. With these container modifications, taken to the level of detail that they are, we don't need to do any drawings, but that is not the norm really.

**Q:** *Are you using any CAM/CNC/robotics-type of automation in your plant currently?*

**A:** In the steel fabrication shop, we do have some of that kind of stuff. At the place that I worked at before, we had jigs where you would layout the joists for the floor system. They would plug their laptop into the piece of equipment, pull up the model that they were going to build, and all of the guys would move to the correct position for whatever partition they were going to build. Then you could just lay your 2x4's into the guides and fasten them. But personally I would like to see us do a lot more with automation, and I would say that most of our better equipment tends to be in the steel fabrication shop. The owner of the

company is fairly conservative about making large capital expenditures and things like that. But as we've changed what we've traditionally built, we have upgraded equipment. Ten years ago the company must have built a lot of portable classrooms and now we do much more non-combustible construction. Things have changed a lot even in the last 6 years since I've worked there which is why I feel positive about the adoption of more prefab construction stuff.

**Q:** *Is there anything from the project that you had a comment on in terms of feasibility?*

**A:** The number one challenge to making a system like that work would be to keep the cost down just because of who your clientele. If you are working in the educational market, you're going to be predominantly working with limited funding and you are often going to be in competitive bid situations. If your system isn't specified in the bid specifications section, you really don't have a way to put your foot in the door. What I do like is that with a tradition modular system you have material redundancies (which are kind of unavoidable). And while you're usually paying to ship an empty volume, I think that with the flat pack system there are pluses and minuses: you will have to construct more onsite and depending on where the site is, you may have expensive labor rates there. But I think that because you have a limited library of components that you are comprising buildings out of, I think that you can use some economies of scale to drive some of those costs down. And that system is broadly applicable, not just to education (though

education is what you are showing in the case study, but there is no reason a similar system can't work for healthcare or retail). And really the broader the range of applications, the more you can drive costs down.

**Q:** *So in the case of this project, if you can bring value engineering to the table I wouldn't necessarily need to sit down with you from day one because this is already taking into consideration some of the design aspects that you think are important for an architect to understand in the beginning?*

**A:** Yes. A lot of the stuff in the project probably doesn't fit with the particular company's business model because our response is typically going to be that we are going to assemble a building that is at least 40% complete when it leaves our factory. This is a lot different of a model than what we typically do. With the skeleton of the building, you are using Lite Steel's product which will be purchased from them and won't be something for us to fabricate. We would typically cold roll our own C-channel, or something at the factory. We'll typically do the framing for interior partitions and stuff like that ourselves because it is cheaper than buying stuff already formed. And we are in a unique situation because we are 5 minutes away from the seventh biggest steel plant in the United States, and we can typically get good prices on steel products. We are not set up to make the panels themselves now, which is why if this is in a real world business model I would say it would take on a similar model as those military container modifications. They

aren't doing work other than the logistics of it – they are sourcing some of the components and we are sourcing some of the components, and they are taking care of some of the logistical things. Some of the things that we are doing now are going to go to Okinawa, so they are taking care of how [the containers] are going to get there and how they are going to be installed. The roof hatches will be sourced because they do projects all over the world and so they can volume purchase them. We will make tube-steel door frames ourselves in the factory. The breachable door assemblies we will subcontract, and in the end we will assemble all of the components and install them in the factory. So I see a business model for it would work like something where we have your [architecture company] in charge of sourcing these components when a customer comes to you, and you will source a general contractor that can do assembly at the site. And I'm not not sure that you need a commercial modular manufacturer in that process. Project Frog, for example, has a company that does custom panels for them (it's their proprietary panel), they have a proprietary steel skeleton that they are using, and they don't need a manufacturer in there because they aren't assembling these components before they get to the site. The kit-of-parts is going to come to the site and get assembled by the general contractor. But I think you could get something like this work because you could model the business as a lease situation where you can defer some of the cost to the school district as there are some benefits to them from a tax-end because of the way that they can depreciate it. Your system

works from state-to-state without problems, you don't have to carry as much inventory. Your inventory would be usable all over the country and overseas, so when that stuff comes off lease and you have another customer that wants to do something completely different there isn't a problem. Whereas, with a typical modular unit, if I have a 24'x60' portable classroom for the school district that has one restroom, when it comes off lease it can be re-leased to someone else only if they have room for a 24'x60' building and only if they need one restroom and two classrooms and only if that building will comply with their state's building codes. With that panelized system that you show here, you've eliminated most of those problems because if they have different space constraints that's not a problem. If they're in a different state that's not a problem. If they need a larger classroom that's not a problem. So I definitely think that there are some benefits there. So you could make it work there as a business model, but there is a thing where you need some volume to get started with. If you are purchasing from a company to do 65 of those SIP's, the price per unit is going to be extremely high. Whereas if you are going to do 1000 of them, your cost is going to come down a lot. So those are the kind of things that you need to work out in the real world. In the past we would push people to do more work in the factory and try to keep more things in our scope of work because that's how we make money. But we've had a little bit of a change of heart in the past few years, and we've seen that there is an opportunity to get more business if you are willing to be realistic about what the best scope of work is.

And in [one] case, we weren't going to be cost competitive doing the full scope of work, but the customer had some timeline concerns. And by doing portions of it prefabricated, which we could do very efficiently in the factory, we could reduce the timeline and still keep the project in budget. Sometimes that is helpful for the client too because another objective that you'll hear sometimes with modular construction is that because you are working in a factory. You are taking away from the economic development of the local community. So in that case we could sell it to the client that you are still creating jobs and economic development locally because there is still quite a bit of work that is going to be done at the site.



## APPENDIX B.5: TRANSCRIPT E

Company E Meeting Transcript

No. of Stakeholders: 1

Type of Interview: Phone Interview

**Q:** *Are you using any CNC or automated machinery for task-oriented operations to assist your production process today?*

**A:** Yes, we have for a while been using CNC roll-forming. Basically how that works is the designer designs the stud layout and the software sends it to the machine which forms the stud, punches the holes for plumbing and electrical, and does all of the assembly features for the assemblers. We're also moving towards a CNC router, which is a basic 3-axis router automation. And we are also going to use a water jet.

**Q:** *Have you faced any issues with the software used with the CNC roll-form?*

**A:** We've actually developed our own software in-house software to do it.

**Q:** *Do you work with architects on your projects?*

**A:** We are the architects. [We do] the design, engineering, manufacturing, shipment, set, and finish. We'll manage the site-work, sometimes help find land, and we'll help with the financing. Overall, we as much as possible try to do everything.

**Q:** *Are you using BIM?*

**A:** We actually use a mechanical engineering software for our CAD backbone which is called CATIA. We've made some customizations to that (adding some custom programmed elements to it), but the backbone of the geometric model is CATIA.

**Q:** *Can you talk about your design process?*

**A:** We're not really a design-build company, but that is the closest analogy to the AEC industry. But we're much more of an "engineering-to-order" product company. So we'll have a set of products which we will configure or customize for an individual customer or site. We have the thing modeled previously and all of the analysis done, and it is a matter of modifying that model and analysis to meet the needs of the site and customer. So if you're familiar with the way that Revit or BIM deals with drawings and models, it's somewhat similar to our process where when we change the model and the shop drawings automatically change. I guess the difference is the tool that we're using is much more geared towards manufacturing and the detail required is far more extensive than would typically output from a BIM system. So a 1,000 square foot house might have 300 pages or so of shop drawings sent to the factory for production.

**Q:** *Why do the drawings have to be so much more detailed for shop drawings?*

**A:** If you speak with any prefab company, probably what you'll hear is that they'll redo all of the drawings or they'll add significantly to the drawings from the architect. Architects don't produce shop drawings typically. They produce construction drawings which can be enough to site build, but that's site building where you have a person that is an industry skilled professional (like let's say a skilled carpenter and a professional skilled foundation person) who can look at an image which is a symbolic representation of what the architect wants, and knows exactly how to detail that out. For example, you don't need to tell a carpenter where to put the nails between two studs. However, if you change to industrialized production where one person is not looking at the drawings for the whole building, and each different assembler doesn't know what the whole of the building is (they just know their one part), they need to be told "OK, there are two studs here, and they need to have two nails to go into them this way." So you have to be much more specific because you're not expecting them to re-interpret the drawing in their mind or through another set of drawings. You're instead expecting them to look at the drawings and follow them. So you could hire someone from any industry: you could hire someone from car manufacturing and give them a job, and tell them "you're now a carpenter, look at these drawings and they'll tell you what to do."

**Q:** *How do you inspect the quality of the work since the modules are isolated?*

**A:** Well one thing is that the next person in line checks the work of the previous person. That's one way. We also have in-house quality assurance people who look at the drawings and walk around checking work as a full-time job. As well as a third-party agency who comes in and confirms that the work being done is per the drawings.

**Q:** *Do you use the 3-D model at all to supplement the drawings on the factory floor?*

**A:** We do use the model, though typically in the quality control realm. No so much yet in production.

**Q:** *Can you list some general design considerations that are unique to modular construction?*

**A:** I guess one thing, a topic that we've already discussed, is specificity. Typically there is much less discussion of this concept of means and methods in prefab than there are in onsite construction. What means and methods is basically the way that things are done in a specific area. So, a foundation is designed this particular way in Massachusetts, and it's typically designed this way in Virginia. Those may be different, but the architect doesn't necessarily need to tell the GC "this is how I want this particular little thing detailed." The same with how you want your base board fastened to or detailed to the wall. What happens when the base board comes in contact with the door trim? Where exactly do the outlets go? Not only how high about

the floor, but exactly where they go? This is because the person that is doing the work doesn't have a floor plan in front of them. They have a drawing that says "here's a picture of a wall, and an outlet goes here, here, and here." If there are no dimensions, they might put an outlet behind a cabinet. So, specificity is incredibly important. Obviously there are shipping and craning concerns, which goes without saying. But because we're not really collaborating with architects very often, and it's mainly the architects that work at [our company] doing the design, we don't deal often with the pitfalls which other people might have been able to mention. Though, it's very important for the designer/architect to know what the factory is good at, to know what their level of finish is, where they can expect quality and where they can't expect quality. Because it's not effective using the same people on every project. So if the architect can go to the factory and look at this house and see that the tile work has 1/8 inch grout, or 1/4 inch grout, and it's not great quality. If 1/16 inch grout with 1" x 1" glass tile imported from somewhere special in a regular pattern [is what] the architect is going to specify perfectly and expect it to be executed perfectly, it's probably a good idea to pick another factory if that is going to be important to them. Because ultimately the same person who did the tile on the building that you just saw is going to be the person doing the tile on your project. It doesn't mean that they're not good, it just means that they're not accustomed to doing the type of work that you might want. So, picking the right factory that you might want and also knowing from that factory what they

are good at, how they do things, what's easy, what's hard, etc. If something is hard for the factory, they're not going to go any slower for your building, particularly when the economy is good. For example, if the building is going to take one day in the drywall phase, and you have very complicated drywall details, they're still only going to spend one day on the drywall phase. This means that probably those details are not going to be executed the way that you want them to. So I think it is very important to understand what is easy for the factory, what is hard for the factory, and not designing something that it is going to be too difficult for them to do a good job on when compared to their standard building practice.

**Q:** *You run an assembly line process correct?*

**A:** Yes.

**Q:** *How many floors do you produce per year?*

**A:** Our factory is capable of producing 1,000 per year.

**Q:** *How many people do you employ?*

**A:** 130, or maybe 150 today.

**Q:** *Do all modular manufacturers require a third-party inspector?*

**A:** I believe that the law requires that all modular manufacturers use a third-party inspection agency. I could be wrong and there could be exceptions, but from what I know, all

factories that are considered modular (at least residential) in the US who benefit from the particular codes and allowances of modular do require a third-party inspection.

**Q:** *And you said that you do all of the work onsite correct?*

**A:** We do act as the builder onsite, but we don't pour the foundation, though we will manage the foundation work.

**Q:** *And that is not just for in-state project, you will do onsite work no matter the location?*

**A:** Correct. We do that work pretty much anywhere in North America right now.

# APPENDIX C: IRB RESEARCH PROTOCOL



## Institutional Review Board Research Protocol

Once complete, upload this form as a Word document to the IRB Protocol Management System: <https://secure.research.vt.edu/irb>

### Section 1: General Information

**1.1 DO ANY OF THE INVESTIGATORS OF THIS PROJECT HAVE A REPORTABLE CONFLICT OF INTEREST?** (<http://www.irb.vt.edu/pages/researchers.htm#conflict>)

- No  
 Yes, explain:

**1.2 WILL THIS RESEARCH INVOLVE COLLABORATION WITH ANOTHER INSTITUTION?**

- No, go to question 1.3  
 Yes, answer questions within table

IF YES
Provide the name of the institution [for institutions located overseas, please also provide name of country]:
Indicate the status of this research project with the other institution's IRB: <input type="checkbox"/> Pending approval <input type="checkbox"/> Approved <input type="checkbox"/> Other institution does not have a human subject protections review board <input type="checkbox"/> Other, explain:
Will the collaborating institution(s) be engaged in the research? <a href="http://www.hhs.gov/ohrp/policy/engage08.html">http://www.hhs.gov/ohrp/policy/engage08.html</a> <input type="checkbox"/> No <input type="checkbox"/> Yes
Will Virginia Tech's IRB review all human subject research activities involved with this project? <input type="checkbox"/> No, provide the name of the primary institution: <input type="checkbox"/> Yes  <i>Note: primary institution = primary recipient of the grant or main coordinating center</i>

**1.3 IS THIS RESEARCH FUNDED?**

- No, go to question 1.4  
 Yes, answer questions within table

IF YES
Provide the name of the sponsor [if NIH, specify department]:
Is this project receiving federal funds? <input type="checkbox"/> No <input type="checkbox"/> Yes  If yes,

1

Does the grant application, OSP proposal, or "statement of work" related to this project include activities involving human subjects that are not covered within this IRB application?

- No, all human subject activities are covered in this IRB application  
 Yes, however these activities will be covered in future VT IRB applications, these activities include:  
 Yes, however these activities have been covered in past VT IRB applications, the IRB number(s) are as follows:  
 Yes, however these activities have been or will be reviewed by another institution's IRB, the name of this institution is as follows:  
 Other, explain:

Is Virginia Tech the primary awardee or the coordinating center of this grant?

- No, provide the name of the primary institution:  
 Yes

**1.4 DOES THIS STUDY INVOLVE CONFIDENTIAL OR PROPRIETARY INFORMATION (OTHER THAN HUMAN SUBJECT CONFIDENTIAL INFORMATION), OR INFORMATION RESTRICTED FOR NATIONAL SECURITY OR OTHER REASONS BY A U.S. GOVERNMENT AGENCY?**

*For example – government / industry proprietary or confidential trade secret information*

- No  
 Yes, describe:

**1.5 DOES THIS STUDY INVOLVE SHIPPING ANY TANGIBLE ITEM, BIOLOGICAL OR SELECT AGENT OUTSIDE THE U.S.?**

- No  
 Yes

### Section 2: Justification

**2.1 DESCRIBE THE BACKGROUND, PURPOSE, AND ANTICIPATED FINDINGS OF THIS STUDY:**

The purpose of this study will be to identify the barriers and constraints to innovation in offsite construction using a case study project. The research will be presented as an exploratory case study, with the aim of being able to provide an understanding of how design and fabrication processes influence one another – design pushing innovation in the building process and technology, and fabrication defining the parameters of design.

The exploratory case study method will be used for this research in order to reveal the broad range of questions that persist in offsite construction. Only when the design challenges and technical limitations of offsite construction are understood, can solutions be pursued. In the end, a comprehensive list of the potential challenges that present themselves during the manufacturing process will be compiled, and solutions will be hypothesized.

**2.2 EXPLAIN WHAT THE RESEARCH TEAM PLANS TO DO WITH THE STUDY RESULTS:**

*For example - publish or use for dissertation*

The study be used for dissertation and will be published to contribute to generalized knowledge.

### Section 3: Recruitment

2

3.1 DESCRIBE THE SUBJECT POOL, INCLUDING INCLUSION AND EXCLUSION CRITERIA AND NUMBER OF SUBJECTS:

Examples of inclusion/exclusion criteria - gender, age, health status, ethnicity

4 building manufacturers (2 minimum) will be interviewed. 2 interviews will be conducted at the plants of the manufacturers, and 2 interviews will be conducted remotely over the phone. 1 of each will be required at the minimum. 2 final interviews (1 minimum) will be done retrospectively to review the results with other industries, getting a second opinion based on alternative building methods. These will be conducted at the plants of the manufacturers also. Duplicate participation levels will be used in order to collect detailed data.

Manufacturers will be represented in the interviews by the following participants: a construction manager, a billing or finance specialist, and a building code research specialist. Group interviews will be used to facilitate the discussion, and to include professionals familiar with all phases of the manufacturing process. Manufacturers who work predominantly on non-residential, permanent buildings will be pursued as collaborators (instead of residential); those selected for participation will have varying fabrication techniques.

3.2 WILL EXISTING RECORDS BE USED TO IDENTIFY AND CONTACT / RECRUIT SUBJECTS?

Examples of existing records - directories, class roster, university records, educational records

- Yes, go to question 3.3
No, answer questions within table

IF YES
Are these records private or public?
Will student, faculty, and/or staff records or contact information be requested from the University?

3.3 DESCRIBE RECRUITMENT METHODS, INCLUDING HOW THE STUDY WILL BE ADVERTISED OR INTRODUCED TO SUBJECTS:

Participants will be asked to be involved in the interviews personally.

3.4 PROVIDE AN EXPLANATION FOR CHOOSING THIS POPULATION:

Note: the IRB must ensure that the risks and benefits of participating in a study are distributed equitably among the general population and that a specific population is not targeted because of ease of recruitment.

The effectiveness of this study is ultimately dependent on the collaboration of participants who share an interest in innovative construction practices and whose goals coincide with the perceived benefits of offsite construction - waste reduction, parallel work, labor productivity and safety, quality control, construction time and cost savings, and the overall reduction of the environmental impact of buildings. Affiliation with the Modular Building Institute and Virginia Tech will be used to aid in the search for participants.

Section 4: Consent Process

For more information about consent process and consent forms visit the following link: http://www.irb.vt.edu/pages/consent.htm

If feasible, researchers are advised and may be required to obtain signed consent from each participant unless obtaining signatures leads to an increase of risk (e.g., the only record linking the subject and the research would be the consent document)

and the principal risk would be potential harm resulting in a breach of confidentiality). Signed consent is typically not required for low risk questionnaires (consent is implied) unless audio/video recording or an in-person interview is involved.

4.1 CHECK ALL OF THE FOLLOWING THAT APPLY TO THIS STUDY'S CONSENT PROCESS:

- Verbal consent will be obtained from participants
Written/signed consent will be obtained from participants
Consent will be implied from the return of completed questionnaire.
Other, describe:

4.2 PROVIDE A GENERAL DESCRIPTION OF THE PROCESS THE RESEARCH TEAM WILL USE TO OBTAIN AND MAINTAIN INFORMED CONSENT:

I will contact select building manufacturers either by phone or via email and ask for their participation in the interview process. Respondants will then follow-up with a list of employees that will be present for the interviews.

4.3 WHO, FROM THE RESEARCH TEAM, WILL BE OVERSEEING THE PROCESS AND OBTAINING CONSENT FROM SUBJECTS?

As the sole interviewer, I (the researcher) will get consent from participants.

4.4 WHERE WILL THE CONSENT PROCESS TAKE PLACE?

Verbal consent will initially be informally asked remotely via email or over the phone. A formal consent form will later be presented at the start of the interview process for face-to-face interviews, and via email a day in advance for over-the-phone interviews.

4.5 DURING WHAT POINT IN THE STUDY PROCESS WILL CONSENTING OCCUR?

Note: unless waived by the IRB, participants must be consented before completing any study procedure, including screening questionnaires.

Initial consent will occur at minimum a week in advance. Later a formal consent form will be presented to participants in face-to-face interviews at the start of the interview, and to participants in over-the-phone interviews a day in advance via email.

4.6 IF APPLICABLE, DESCRIBE HOW THE RESEARCHERS WILL GIVE SUBJECTS AMPLE TIME TO REVIEW THE CONSENT DOCUMENT BEFORE SIGNING:

Note: typically applicable for complex studies, studies involving more than one session, or studies involving more of a risk to subjects.

Not applicable

Section 5: Procedures

5.1 PROVIDE A STEP-BY-STEP THOROUGH EXPLANATION OF ALL STUDY PROCEDURES EXPECTED FROM STUDY PARTICIPANTS, INCLUDING TIME COMMITMENT & LOCATION:

Both face-to-face interviews and over-the-phone interviews will be conducted in a 3-step process. First, the description and drawings of the case study project will be distributed to the participants ahead of time (at minimum 1 week). The participants will be given the time to review the project at their own leisure (will likely take an hour to review the content). Second, the project will be reviewed at the start of the interview process. Questions will be fielded about the project in order to make sure the design intent is understood. This project review will be recorded as part of the discussion as I am looking for anything in the reactions of the manufacturers that will give an indication as to what can be done in their current fabrication process. Finally, an identical set of pre-determined questions will be asked to the participants. The questions will be semi-structured and open ended. Free discussion can ensue in response to any one question, yet I will be sure to prevent one person in the group from dominating the discussion, and I will be sure to get each person's response to each individual topic. Not all questions will be asked verbatim, but I will judge whether each topic is adequately covered. This will allow the discussion to be fluid and to evolve, and participants will be free to ask questions themselves. The interview in total will be a minimum of 1 hour in length.

I will be visiting the manufacturing plants for face-to-face interviews, and will ask ahead of time to tour the plant in order to observe the fabrication process and plant layout of the manufacturers. This will take a minimum of 30 minutes, depending on the time the participants have available to meet with me. Both over-the-phone and retrospective interviews will be done remotely without visiting the plants of the manufacturers. Retrospective interviews (also face-to-face) will be done last, after I am given time to review the responses and observations from the prior interviews. Additional questions or modified questions will likely be presented during retrospective interviews after I am given a chance to review the previous discussions.

5.2 DESCRIBE HOW DATA WILL BE COLLECTED AND RECORDED:

All interviews will be tape recorded and transcribed at a later date. During each interview, I will make generalized notes that will be organized according to the structure of the questionnaire. The transcriptions will be made available to participants at their request.

5.3 DOES THE PROJECT INVOLVE ONLINE RESEARCH ACTIVITIES (INCLUDES ENROLLMENT, RECRUITMENT, SURVEYS)?

View the "Policy for Online Research Data Collection Activities Involving Human Subjects" at <http://www.irb.vt.edu/documents/onlinepolicy.pdf>

- No, go to question 6.1
 Yes, answer questions within table

IF YES
Identify the service / program that will be used:
www.survey.vt.edu, go to question 6.1
Blackboard, go to question 6.1
Center for Survey Research, go to question 6.1
Other
IF OTHER:
Name of service / program:
URL:
This service is...
Included on the list found at: http://www.irb.vt.edu/pages/validated.htm
Approved by VT IT Security
An external service with proper SSL or similar encryption (https://) on the login (if applicable) and all other data collection pages.
None of the above (note: only permissible if this is a collaborative project in which VT individuals are only responsible for data analysis, consulting, or recruitment)

Section 6: Risks and Benefits

6.1 WHAT ARE THE POTENTIAL RISKS (E.G., EMOTIONAL, PHYSICAL, SOCIAL, LEGAL, ECONOMIC, OR DIGNITY) TO STUDY PARTICIPANTS?

In the study, I will present a theoretical project design to participants and record their reactions/opinions about it, and to collectively hypothesize how it could be achieved through offsite construction processes. There is a remote possibility that participants risk embarrassment in their lack of knowledge about technology available within the industry or to their understanding/reading of the project drawings.

6.2 EXPLAIN THE STUDY'S EFFORTS TO REDUCE POTENTIAL RISKS TO SUBJECTS:

I will make every effort in the data analysis to omit anything from the discussions that could be embarrassing regarding a lack of knowledge from the participants.

6.3 WHAT ARE THE DIRECT OR INDIRECT ANTICIPATED BENEFITS TO STUDY PARTICIPANTS AND/OR SOCIETY?

Ultimately, the benefits to the participants is that the information from the study should be helpful for architects in their understanding as to what is possible with offsite construction, and what is being currently done by building manufacturers that provide new design and building opportunities that are currently unknown by architects. Or at least to raise the questions regarding the current and future direction of the industry and what needs to be overcome technologically before benefits from offsite construction processes can be realized.

Section 7: Full Board Assessment

7.1 DOES THE RESEARCH INVOLVE MICROWAVES/X-RAYS, OR GENERAL ANESTHESIA OR SEDATION?

- No
 Yes

7.2 DO RESEARCH ACTIVITIES INVOLVE PRISONERS, PREGNANT WOMEN, FETUSES, HUMAN IN VITRO FERTILIZATION, OR MENTALLY DISABLED PERSONS?

- No, go to question 7.3
 Yes, answer questions within table

IF YES
This research involves:
Prisoners
Pregnant women
Fetuses
Human in vitro fertilization
Mentally disabled persons

7.3 DOES THIS STUDY INVOLVE MORE THAN MINIMAL RISK TO STUDY PARTICIPANTS?

Minimal risk means that the probability and magnitude of harm or discomfort anticipated in the research are not greater in and of themselves than those ordinarily encountered in daily activities or during the performance of routine physical or psychological examinations or tests. Examples of research involving greater than minimal risk include collecting data about abuse or illegal activities. Note: if the project qualifies for Exempt review (http://www.irb.vt.edu/pages/categories.htm), it will not need to go to the Full Board.

- No

Yes

IF YOU ANSWERED "YES" TO ANY ONE OF THE ABOVE QUESTIONS, 7.1, 7.2, OR 7.3, THE BOARD MAY REVIEW THE PROJECT'S APPLICATION MATERIALS AT ITS MONTHLY MEETING. VIEW THE FOLLOWING LINK FOR DEADLINES AND ADDITIONAL INFORMATION: <http://www.irb.vt.edu/pages/deadlines.htm>

### Section 8: Confidentiality / Anonymity

For more information about confidentiality and anonymity visit the following link: <http://www.irb.vt.edu/pages/confidentiality.htm>

#### 8.1 WILL PERSONALLY IDENTIFYING STUDY RESULTS OR DATA BE RELEASED TO ANYONE OUTSIDE OF THE RESEARCH TEAM?

For example – to the funding agency or outside data analyst, or participants identified in publications with individual consent

No  
 Yes, to whom will identifying data be released?

#### 8.2 WILL ANY STUDY FILES CONTAIN PARTICIPANT IDENTIFYING INFORMATION (E.G., NAME, CONTACT INFORMATION, VIDEO/AUDIO RECORDINGS)?

Note: if collecting signatures on a consent form, select "Yes."

No, go to question 8.3  
 Yes, answer questions within table

IF YES
Describe if/how the study will utilize study codes: <b>Because confidentiality will be maintained, the names of participants (company name, employee name and contact information) will be coded based on a company identification number, and employee identification number (ie: 1,1).</b>
<b>If applicable, where will the key [i.e., linked code and identifying information document (for instance, John Doe = study ID 001)] be stored and who will have access? I as the researcher (and lone interviewer) will have access to the key. The key will be stored only electronically with the recorded interviews, and will be separated from the data analysis.</b>
<i>Note: the key should be stored separately from subjects' completed data documents and accessibility should be limited.</i>
<i>The IRB strongly suggests and may require that all data documents (e.g., questionnaire responses, interview responses, etc.) do not include or request identifying information (e.g., name, contact information, etc.) from participants. If you need to link subjects' identifying information to subjects' data documents, use a study ID/code on all data documents.</i>

#### 8.3 WHERE WILL DATA BE STORED?

Examples of data - questionnaire, interview responses, downloaded online survey data, observation recordings, biological samples

Data will be stored on an external hard drive in which I, as the researcher (and lone interviewer) will have access to. Paper notes taken during the interview process will be scanned, stored, and disposed of.

#### 8.4 WHO WILL HAVE ACCESS TO STUDY DATA?

I be the only one to have access to the study data as the researcher, and lone interviewer. If written transcript from the interview is asked for by the participants, the transcripts will be electronically sent to the participants.

#### 8.5 DESCRIBE THE PLANS FOR RETAINING OR DESTROYING THE STUDY DATA

Study data will be stored in an external hard drive in which I will have lone access to. Interview data will be deleted one year (at maximum) after final submittal of thesis document.

#### 8.6 DOES THIS STUDY REQUEST INFORMATION FROM PARTICIPANTS REGARDING ILLEGAL BEHAVIOR?

No, go to question 9.1  
 Yes, answer questions within table

IF YES
Does the study plan to obtain a Certificate of Confidentiality? <input type="checkbox"/> No <input type="checkbox"/> Yes (Note: participants must be fully informed of the conditions of the Certificate of Confidentiality within the consent process and form)
For more information about Certificates of Confidentiality, visit the following link: <a href="http://www.irb.vt.edu/pages/coc.htm">http://www.irb.vt.edu/pages/coc.htm</a>

### Section 9: Compensation

For more information about compensating subjects, visit the following link: <http://www.irb.vt.edu/pages/compensation.htm>

#### 9.1 WILL SUBJECTS BE COMPENSATED FOR THEIR PARTICIPATION?

No, go to question 10.1  
 Yes, answer questions within table

IF YES
What is the amount of compensation?
Will compensation be prorated? <input type="checkbox"/> Yes, please describe: <input type="checkbox"/> No, explain why and clarify whether subjects will receive full compensation if they withdraw from the study?
<i>Unless justified by the researcher, compensation should be prorated based on duration of study participation. Payment must not be contingent upon completion of study procedures. In other words, even if the subject decides to withdraw from the study, he/she should be compensated, at least partially, based on what study procedures he/she has completed.</i>

### Section 10: Audio / Video Recording

For more information about audio/video recording participants, visit the following link: <http://www.irb.vt.edu/pages/recordings.htm>

#### 10.1 WILL YOUR STUDY INVOLVE VIDEO AND/OR AUDIO RECORDING?

- No, go to question 11.1
- Yes, answer questions within table

IF YES
<p><b>This project involves:</b></p> <ul style="list-style-type: none"> <li><input checked="" type="checkbox"/> Audio recordings only</li> <li><input type="checkbox"/> Video recordings only</li> <li><input type="checkbox"/> Both video and audio recordings</li> </ul>
<p>Provide compelling justification for the use of audio/video recording: The interviews will involve both an open discussion of the case study project and the responses to a series of open-ended questions. Because I will both be recording responses and participating in the discussions (to facilitate discussion and to answer questions asked by the participants), the use of an audio recording device will assist me in my recall of the conversations at a later date when I am trying to summarize and analyze what was said.</p>
<p>How will data within the recordings be retrieved / transcribed? Data within the recordings will be transcribed, though not word for word because of the anticipated length of the discussion, but summarized depending of the length of the responses. Segments of the recordings will also be omitted in the transcriptions based on their relevance.</p>
<p>How and where will recordings (e.g., tapes, digital data, data backups) be stored to ensure security? Recordings will be stored on an external hard drive along with all private data collected from the study, and will be deleted at a later date as mentioned earlier.</p>
<p>Who will have access to the recordings? I will have access to the full audio recordings as the researcher and lone interviewer. Transcripts, as described earlier, will be available to participants at their request.</p>
<p>Who will transcribe the recordings? I will transcribe the recordings as the researcher and lone interviewer.</p>
<p>When will the recordings be erased / destroyed? The recordings will be erased from the external hard drive one year after the final submission of the thesis document.</p>

**Section 11: Research Involving Students**

**11.1 DOES THIS PROJECT INCLUDE STUDENTS AS PARTICIPANTS?**

- No, go to question 12.1
- Yes, answer questions within table

IF YES
<p>Does this study involve conducting research with students of the researcher?</p> <ul style="list-style-type: none"> <li><input type="checkbox"/> No</li> <li><input type="checkbox"/> Yes, describe safeguards the study will implement to protect against coercion or undue influence for participation:</li> </ul> <p><i>Note: if it is feasible to use students from a class of students not under the instruction of the researcher, the IRB recommends and may require doing so.</i></p>
<p>Will the study need to access student records (e.g., SAT, GPA, or GRE scores)?</p> <ul style="list-style-type: none"> <li><input type="checkbox"/> No</li> </ul>

<input type="checkbox"/> Yes
------------------------------

**11.2 DOES THIS PROJECT INCLUDE ELEMENTARY, JUNIOR, OR HIGH SCHOOL STUDENTS?**

- No, go to question 11.3
- Yes, answer questions within table

IF YES
<p>Will study procedures be completed during school hours?</p> <ul style="list-style-type: none"> <li><input type="checkbox"/> No</li> <li><input type="checkbox"/> Yes</li> </ul> <p>If yes,</p> <p style="text-align: center;">Students not included in the study may view other students' involvement with the research during school time as unfair. Address this issue and how the study will reduce this outcome:</p> <p style="text-align: center;">Missing out on regular class time or seeing other students participate may influence a student's decision to participate. Address how the study will reduce this outcome:</p>
<p>Is the school's approval letter(s) attached to this submission?</p> <ul style="list-style-type: none"> <li><input type="checkbox"/> Yes</li> <li><input type="checkbox"/> No, project involves Montgomery County Public Schools (MCPS)</li> <li><input type="checkbox"/> No, explain why:</li> </ul> <p><i>You will need to obtain school approval (if involving MCPS, click here: <a href="http://www.irb.vt.edu/pages/mcps.htm">http://www.irb.vt.edu/pages/mcps.htm</a>). Approval is typically granted by the superintendent, principal, and classroom teacher (in that order). Approval by an individual teacher is insufficient. School approval, in the form of a letter or a memorandum should accompany the approval request to the IRB.</i></p>

**11.3 DOES THIS PROJECT INCLUDE COLLEGE STUDENTS?**

- No, go to question 12.1
- Yes, answer questions within table

IF YES
<p>Some college students might be minors. Indicate whether these minors will be included in the research or actively excluded:</p> <ul style="list-style-type: none"> <li><input type="checkbox"/> Included</li> <li><input type="checkbox"/> Actively excluded, describe how the study will ensure that minors will not be included:</li> </ul>
<p>Will extra credit be offered to subjects?</p> <ul style="list-style-type: none"> <li><input type="checkbox"/> No</li> <li><input type="checkbox"/> Yes</li> </ul> <p>If yes,</p> <p style="text-align: center;">What will be offered to subjects as an equal alternative to receiving extra credit without participating in this study?</p> <p style="text-align: center;">Include a description of the extra credit (e.g., amount) to be provided within question 9.1 ("IF YES" table)</p>



**Section 12: Research Involving Minors**

**12.1 DOES THIS PROJECT INVOLVE MINORS (UNDER THE AGE OF 18 IN VIRGINIA)?**

*Note: age constituting a minor may differ in other States.*

- No, go to question 13.1
- Yes, answer questions within table

IF YES
<p><b>Does the project reasonably pose a risk of reports of current threats of abuse and/or suicide?</b></p> <p><input type="checkbox"/> No</p> <p><input type="checkbox"/> Yes, thoroughly explain how the study will react to such reports:</p> <p><i>Note: subjects and parents must be fully informed of the fact that researchers must report threats of suicide or suspected/reported abuse to the appropriate authorities within the Confidentiality section of the Consent, Assent, and/or Permission documents.</i></p>
<p><b>Are you requesting a waiver of parental permission (i.e., parent uninformed of child's involvement)?</b></p> <p><input type="checkbox"/> No, both parents/guardians will provide their permission, if possible.</p> <p><input type="checkbox"/> No, only one parent/guardian will provide permission.</p> <p><input type="checkbox"/> Yes, describe below how your research meets <b>all</b> of the following criteria (A-D):</p> <p>Criteria A - The research involves no more than minimal risk to the subjects:  Criteria B - The waiver will not adversely affect the rights and welfare of the subjects:  Criteria C - The research could not practicably be carried out without the waiver:  Criteria D - (Optional) Parents will be provided with additional pertinent information after participation:</p>
<p><b>Is it possible that minor research participants will reach the legal age of consent (18 in Virginia) while enrolled in this study?</b></p> <p><input type="checkbox"/> No</p> <p><input type="checkbox"/> Yes, will the investigators seek and obtain the legally effective informed consent (in place of the minors' previously provided assent and parents' permission) for the now-adult subjects for any ongoing interactions with the subjects, or analysis of subjects' data? If yes, explain how:</p> <p><i>For more information about minors reaching legal age during enrollment, visit the following link:  <a href="http://www.irb.vt.edu/pages/assent.htm">http://www.irb.vt.edu/pages/assent.htm</a></i></p> <p><i>The procedure for obtaining assent from minors and permission from the minor's guardian(s) must be described in Section 4 (Consent Process) of this form.</i></p>

**Section 13: Research Involving Deception**

For more information about involving deception in research and for assistance with developing your debriefing form, visit our website at <http://www.irb.vt.edu/pages/deception.htm>

**13.1 DOES THIS PROJECT INVOLVE DECEPTION?**

- No, go to question 14.1
- Yes, answer questions within table

IF YES
<b>Describe the deception:</b>
<b>Why is the use of deception necessary for this project?</b>
<b>Describe the debriefing process:</b>
<p><b>Provide an explanation of how the study meets <b>all</b> the following criteria (A-D) for an alteration of consent:</b></p> <p>Criteria A - The research involves no more than minimal risk to the subjects:  Criteria B - The alteration will not adversely affect the rights and welfare of the subjects:  Criteria C - The research could not practicably be carried out without the alteration:  Criteria D - (Optional) Subjects will be provided with additional pertinent information after participation (i.e., debriefing for studies involving deception):</p> <p><i>By nature, studies involving deception cannot provide subjects with a complete description of the study during the consent process; therefore, the IRB must allow (by granting an alteration of consent) a consent process which does not include, or which alters, some or all of the elements of informed consent.</i></p> <p><i>The IRB requests that the researcher use the title "Information Sheet" instead of "Consent Form" on the document used to obtain subjects' signatures to participate in the research. This will adequately reflect the fact that the subject cannot fully consent to the research without the researcher fully disclosing the true intent of the research.</i></p>

**Section 14: Research Involving Existing Data**

**14.1 WILL THIS PROJECT INVOLVE THE COLLECTION OR STUDY/ANALYSIS OF EXISTING DATA DOCUMENTS, RECORDS, PATHOLOGICAL SPECIMENS, OR DIAGNOSTIC SPECIMENS?**

*Please note: it is not considered existing data if a researcher transfers to Virginia Tech from another institution and will be conducting data analysis of an on-going study.*

- No, you are finished with the application
- Yes, answer questions within table

IF YES
<b>From where does the existing data originate?</b>
<b>Provide a detailed description of the existing data that will be collected or studied/analyzed:</b>
<p><b>Is the source of the data public?</b></p> <p><input type="checkbox"/> No, continue with the next question</p> <p><input type="checkbox"/> Yes, you are finished with this application</p>
<p><b>Will any individual associated with this project (internal or external) have access to or be provided with existing data containing information which would enable the identification of subjects:</b></p> <ul style="list-style-type: none"> <li>▪ <b>Directly</b> (e.g., by name, phone number, address, email address, social security number, student ID number), or</li> <li>▪ <b>Indirectly through study codes</b> even if the researcher or research team does not have access to the master list linking study codes to identifiable information such as name, student ID number, etc or</li> <li>▪ <b>Indirectly through the use of information that could reasonably be used in combination to identify an individual</b> (e.g., demographics)</li> </ul> <p><input type="checkbox"/> No, collected/analyzed data will be completely de-identified</p>

Yes,  
**If yes,**  
*Research will not qualify for exempt review; therefore, if feasible, written consent must be obtained from individuals whose data will be collected / analyzed, unless this requirement is waived by the IRB.*  
**Will written/signed or verbal consent be obtained from participants prior to the analysis of collected data? -select one-**

*This research protocol represents a contract between all research personnel associated with the project, the University, and federal government; therefore, must be followed accordingly and kept current.*

*Proposed modifications must be approved by the IRB prior to implementation except where necessary to eliminate apparent immediate hazards to the human subjects.*

*Do not begin human subjects activities until you receive an IRB approval letter via email.*

*It is the Principal Investigator's responsibility to ensure all members of the research team who interact with research subjects, or collect or handle human subjects data have completed human subjects protection training prior to interacting with subjects, or handling or collecting the data.*

-----END-----