

House I

Hoi San Sio

Thesis submitted to the faculty of Virginia Polytechnic Institute and State University in partial fulfillment of the requirements for the degree of

Master of Architecture.

Hans Christian Rott  
Chairman

H. Scott Gartner

William U. Galloway

April 27, 2011  
Blacksburg, Virginia

Keywords: centralization, transparency, idealized color

House I

Hoi San Sio

ABSTRACT

This thesis began with an interest in apartment housing typology. I am familiar with this typology, yet it remains mysterious. The topic was never touched on in five years of architectural education or the time spent working in firms. I felt the need to study this typology.

It is through the repetition of working with the realization that the hand and mind are one; I understand what I am working toward and the hand informs the mind of what it is doing.

The notion of centralization, transparency, spatial ambiguity, symmetry, dematerialization, are used as a method to organize space and architectural elements. Spatial orders and conditions are examined through the use of idealized color.

This work is the result of a year long study of the above architectural vocabulary. It is my hope that through this study, I can begin to establish a point of view.

This thesis is a cross section of a thought.

## ACKNOWLEDGEMENTS

Thank you.

I am grateful for my family and friends. Dad, Mom, and my sister Lucia, their unending support is what made me who I am today. I thank Sally Chiu, Mansi Ng, Jared Boudreaux and Lionel Wan, for their honesty and friendship. Laura Thomas has been my critic since our undergraduate days, my work has improved immeasurably because of her help and involvements. Thank you.

I offer my sincerest gratitude to my committee, Hans Rott, Scott Gartner, Bill Galloway, and Steve Thompson. Thank you for supporting and guiding me throughout my thesis with knowledge and advice while allowing me room and freedom to express who I am. Thank you.

This would not have been possible without Rehanna Rojiani and Gavin Argo. I am fortunate to share the corner with them, while their support and enthusiasm provide tremendous inspiration. I have learned so much from them.

Thank you.

I have titled this thesis “House I” as a commitment to a life long study, and as an homage to the New York Five.

## TABLE OF CONTENTS

Abstract	ii
Acknowledgments	iii
1      Sketches	1
2      Paintings	18
3      Drawings	34
4      Models	48

My method of working is not linear.  
This book is broken down into sections, but it should be read as a whole.

SKETCHES

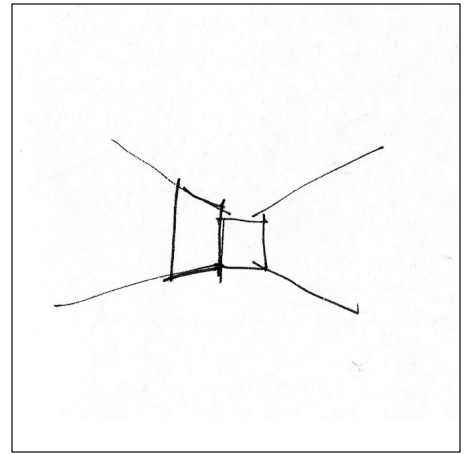
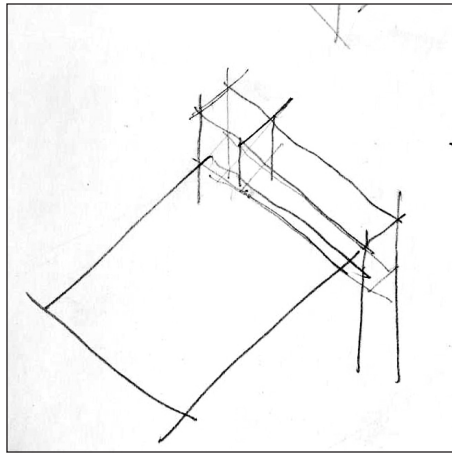
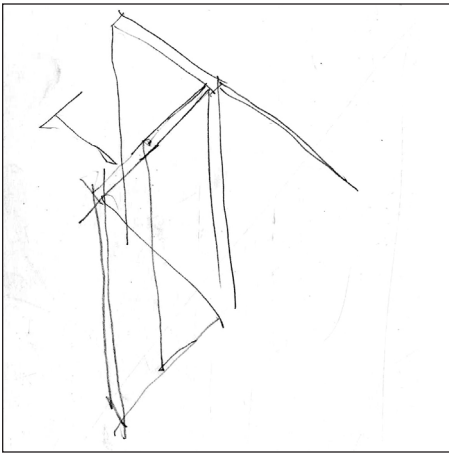
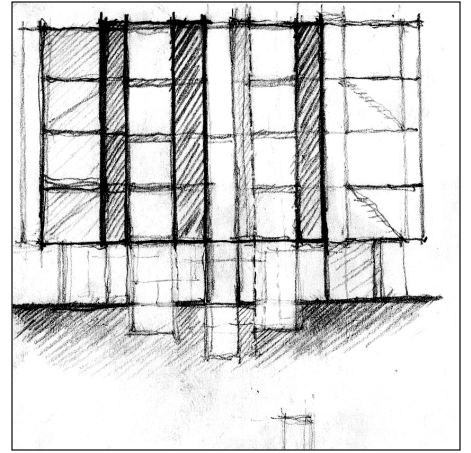
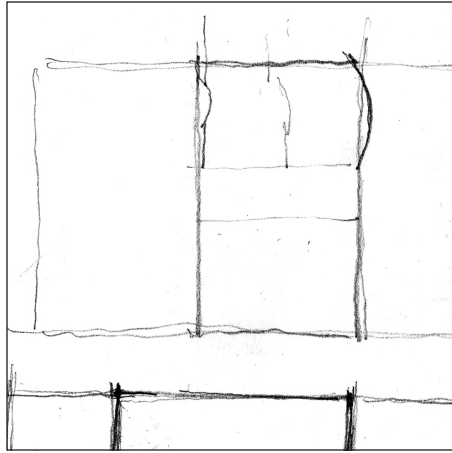
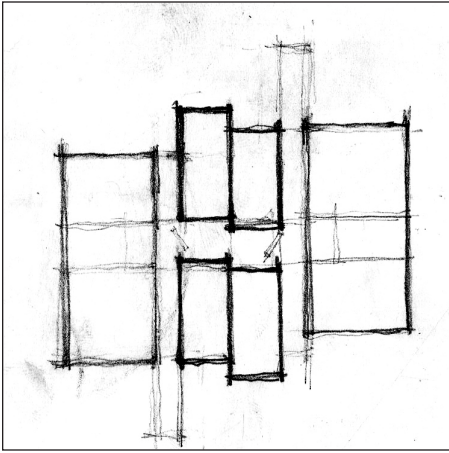

2

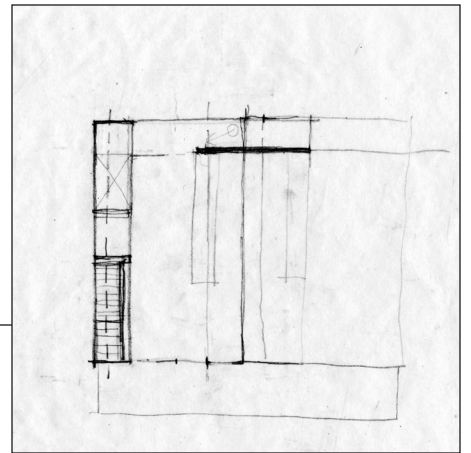
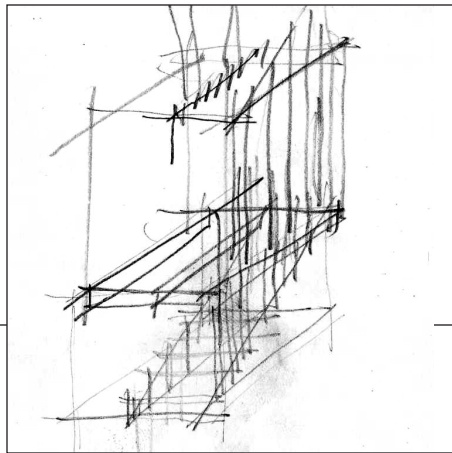
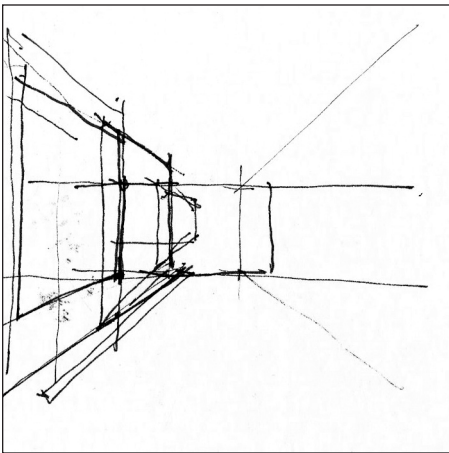

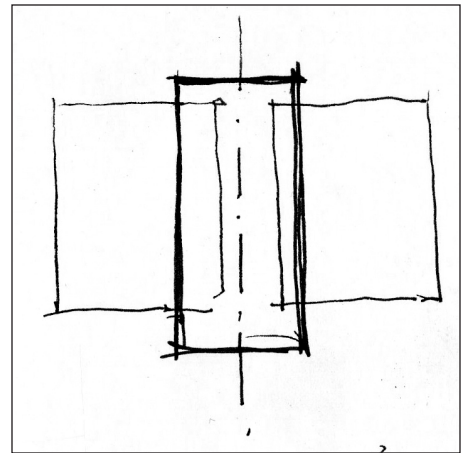
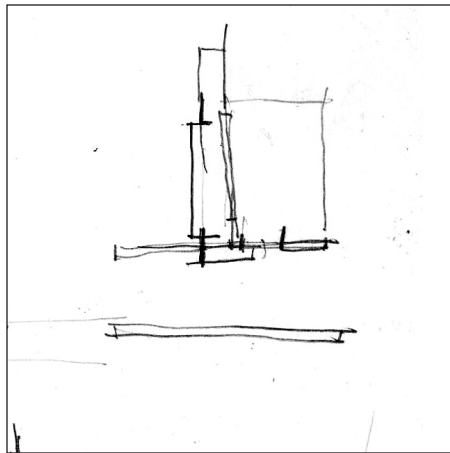
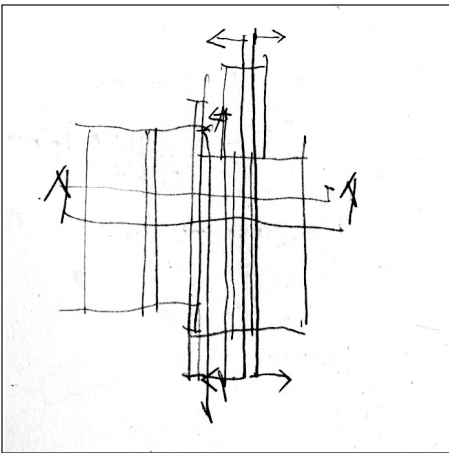
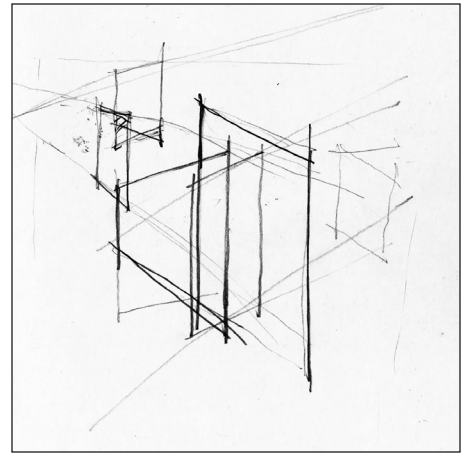
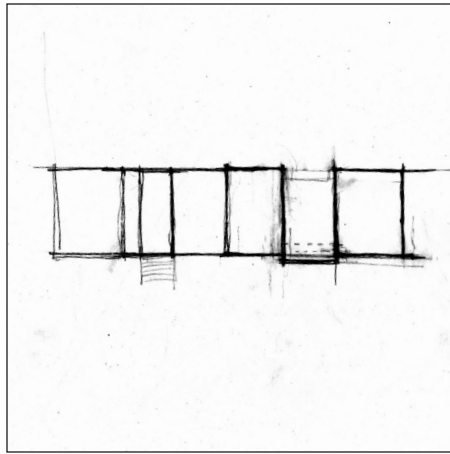
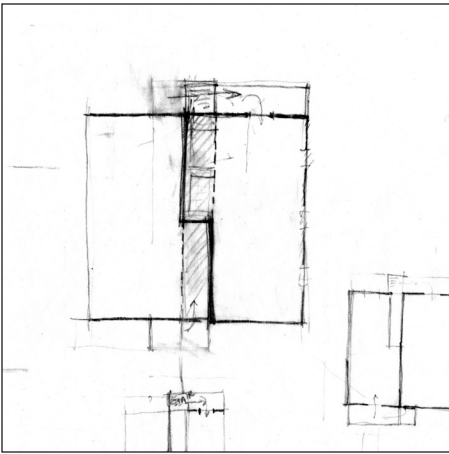
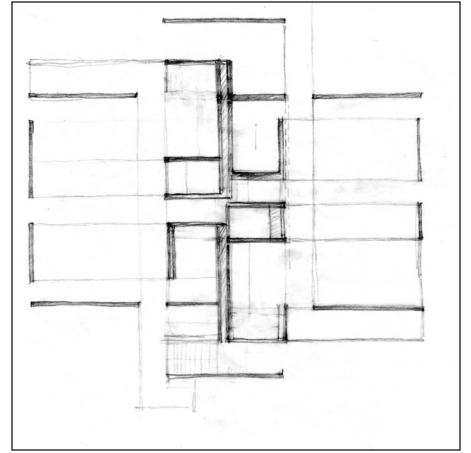
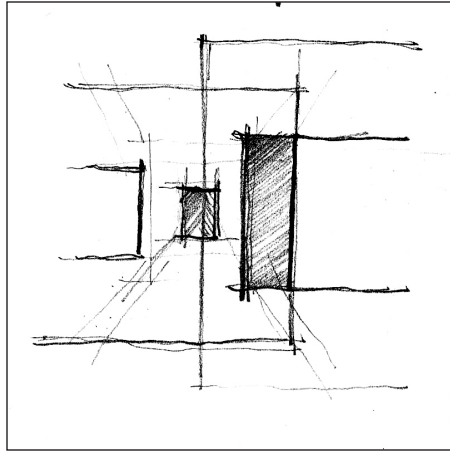
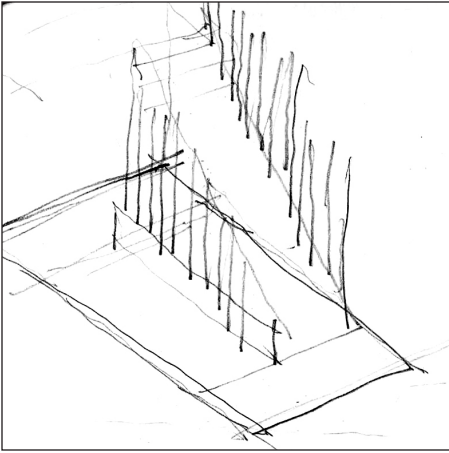



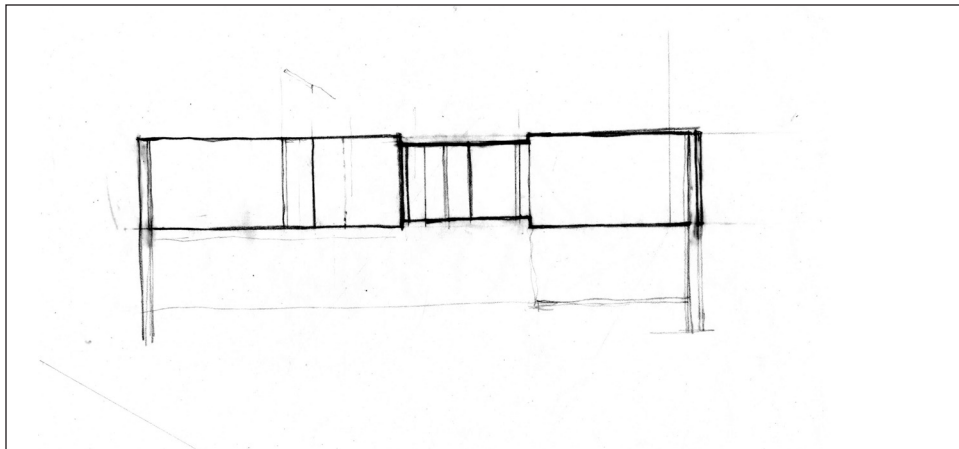
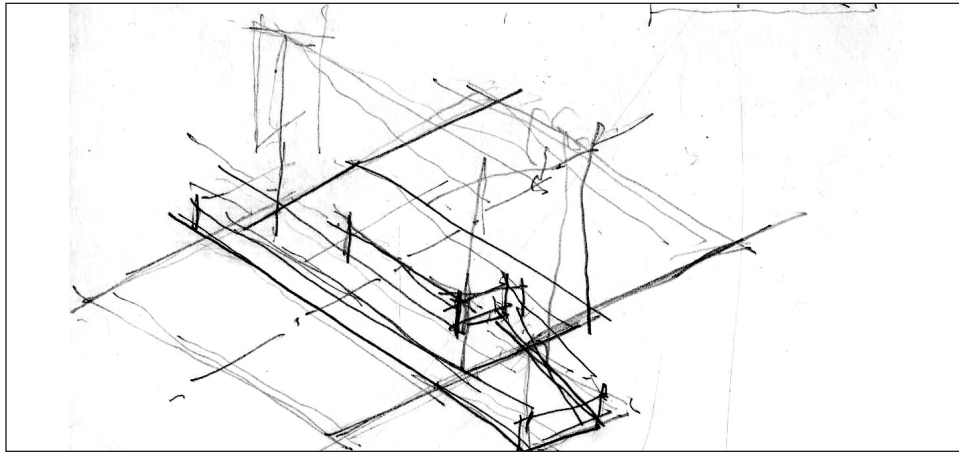
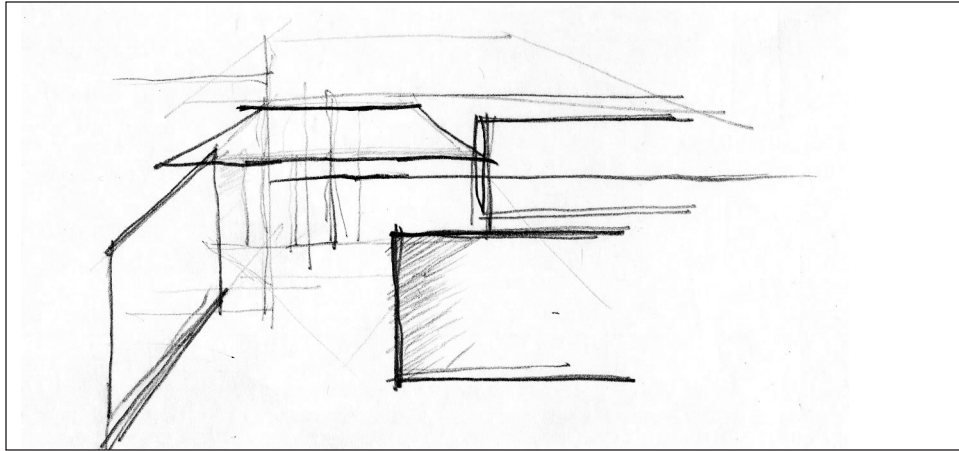

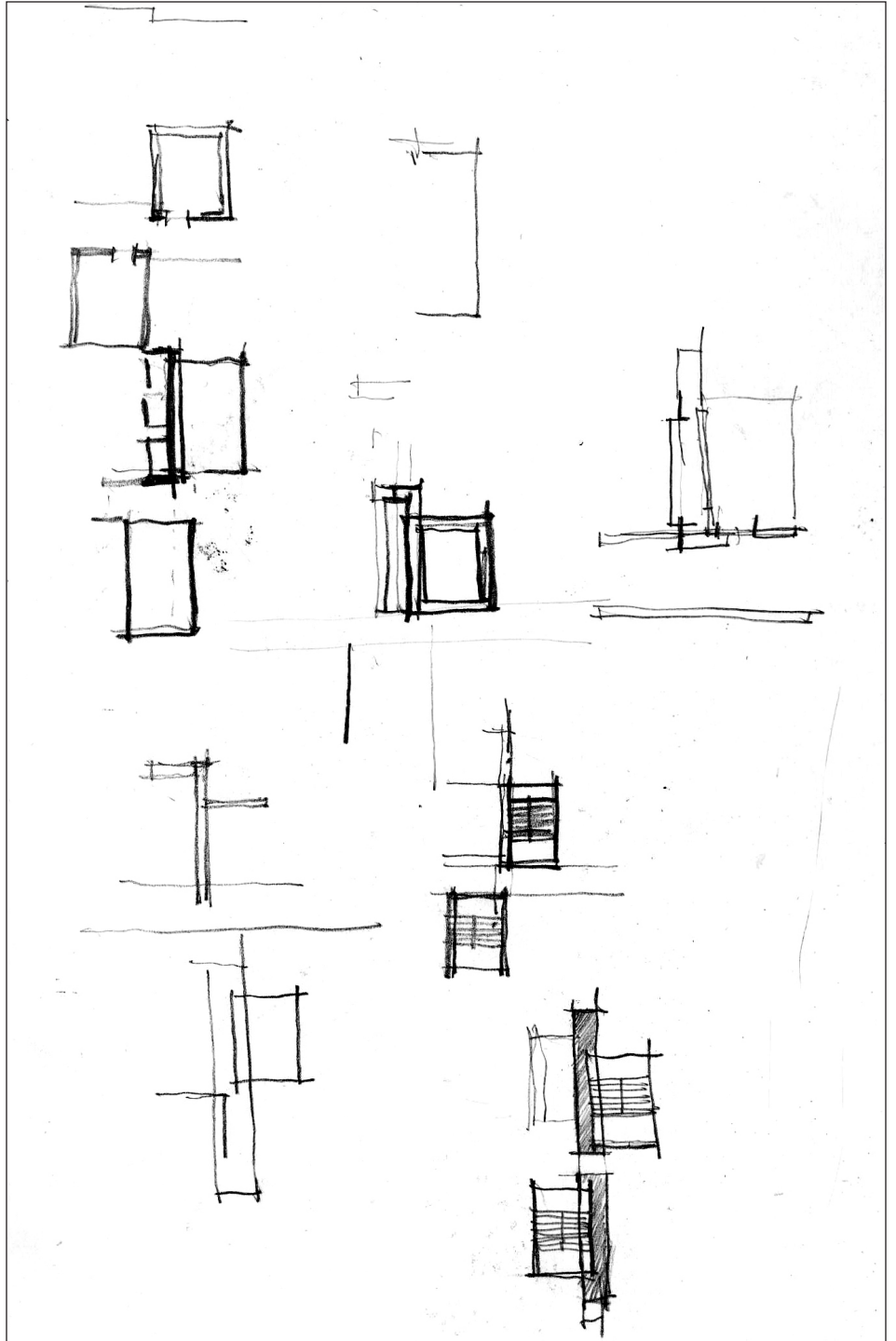
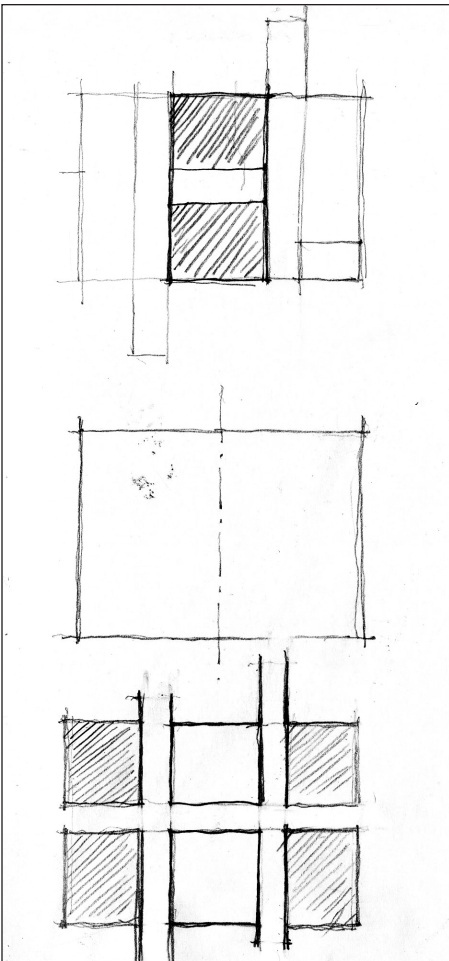
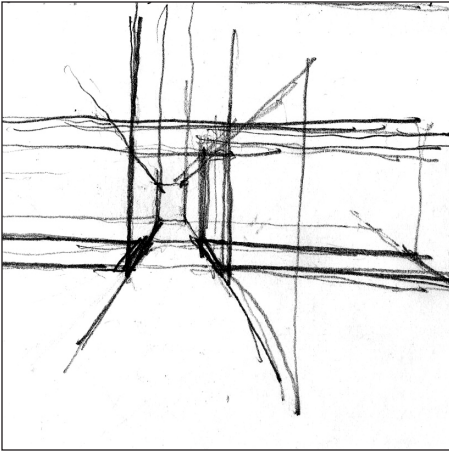

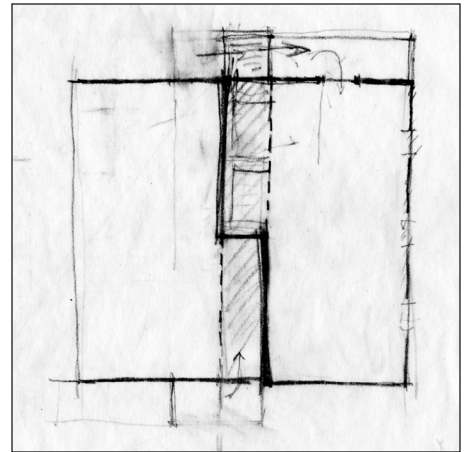
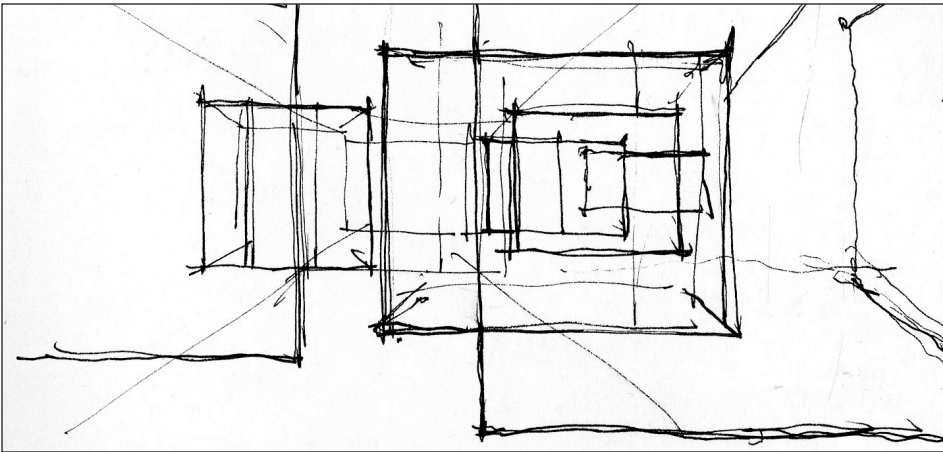
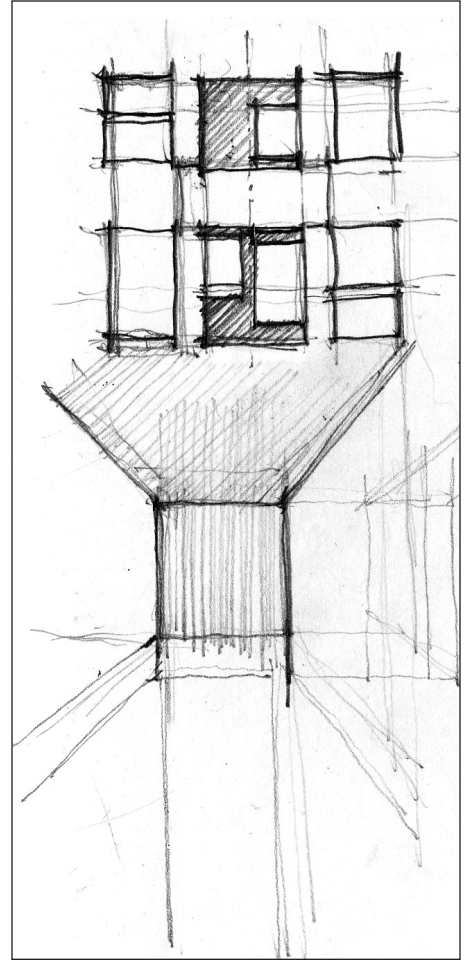
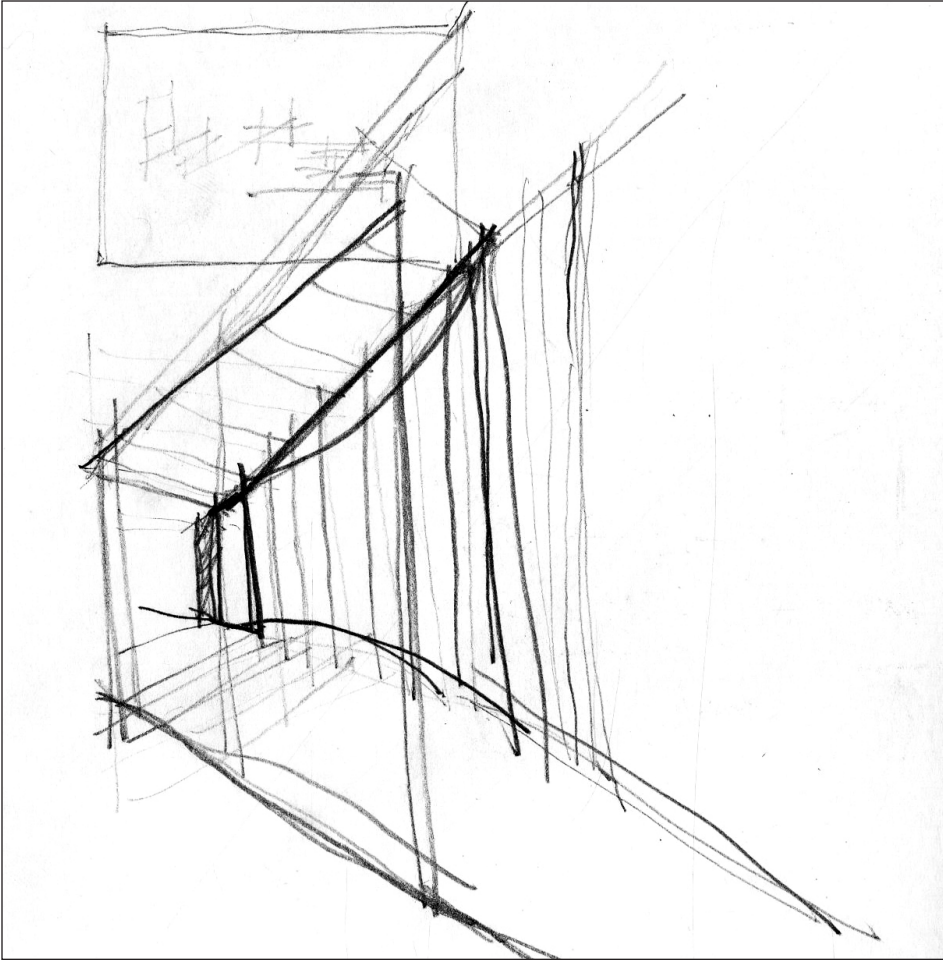

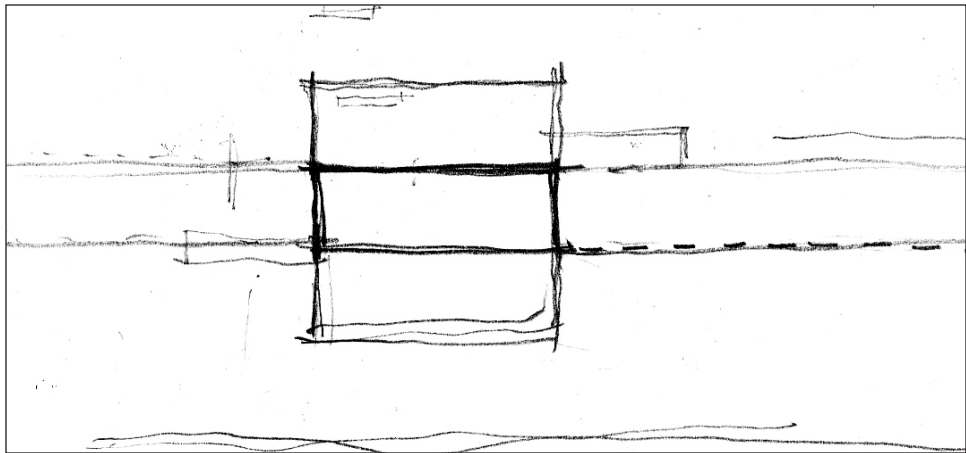
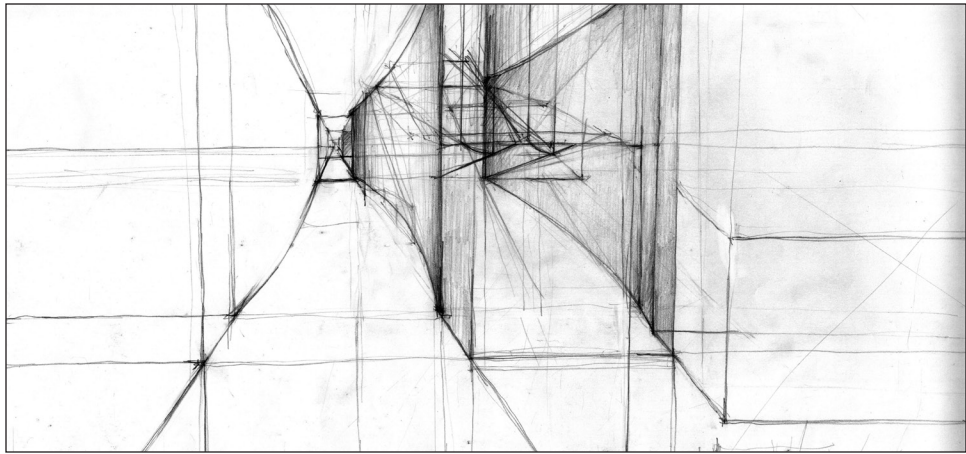
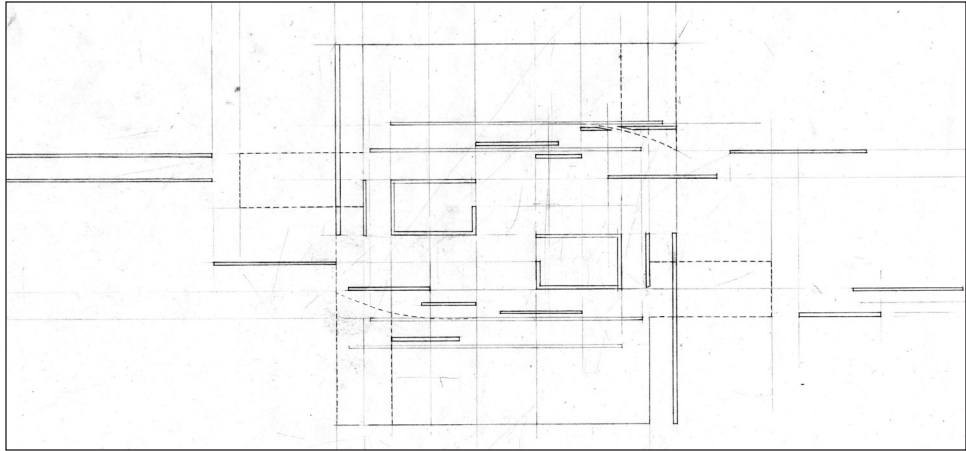

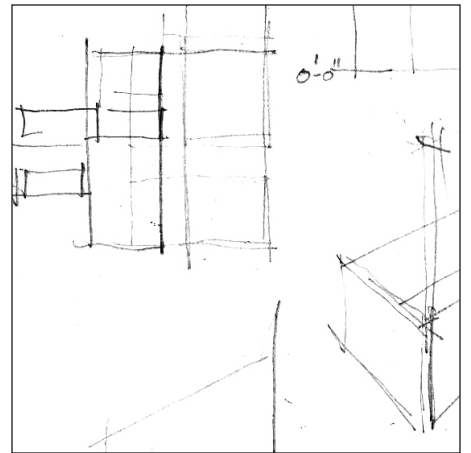
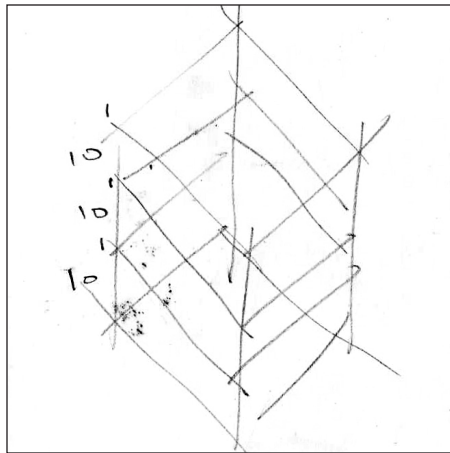
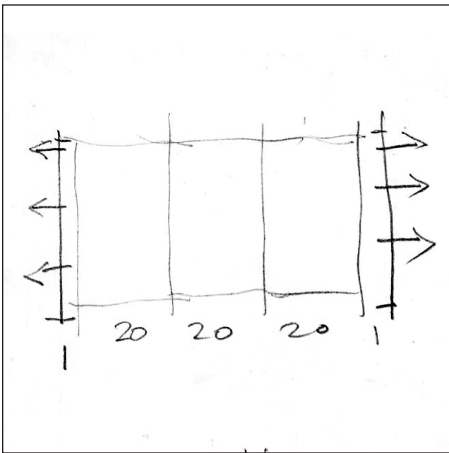
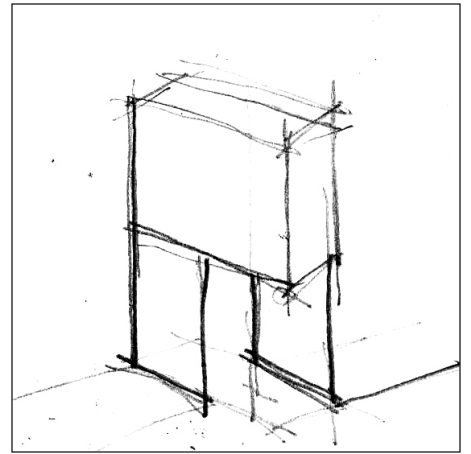
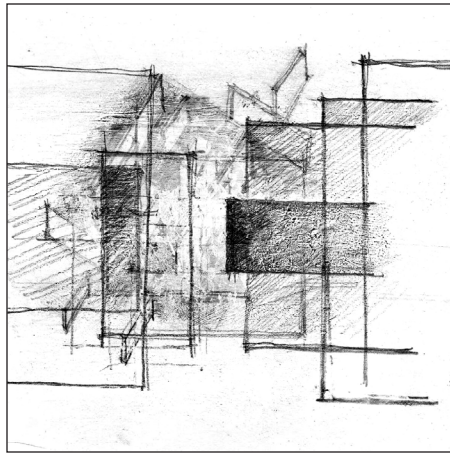
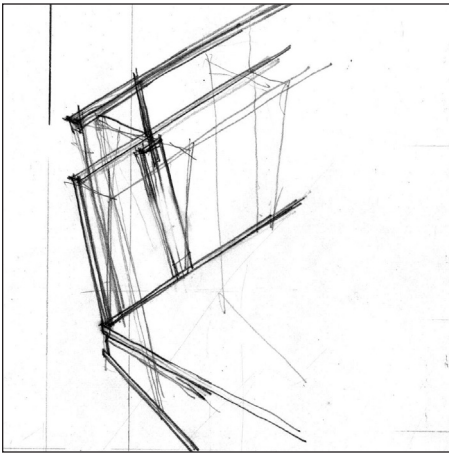
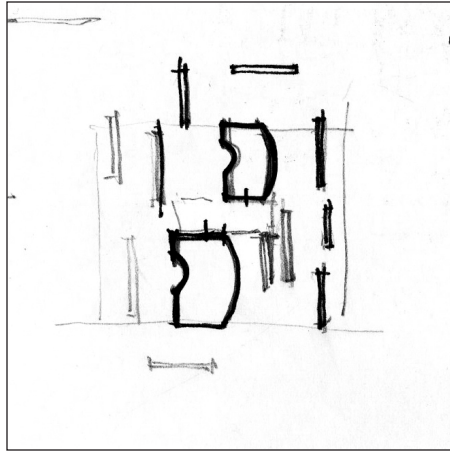
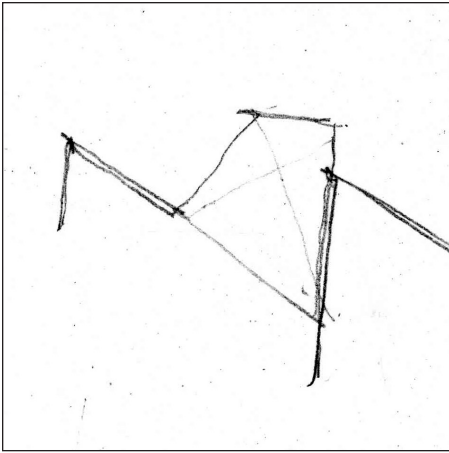

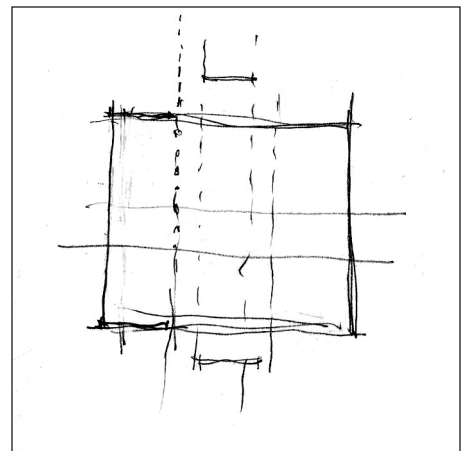
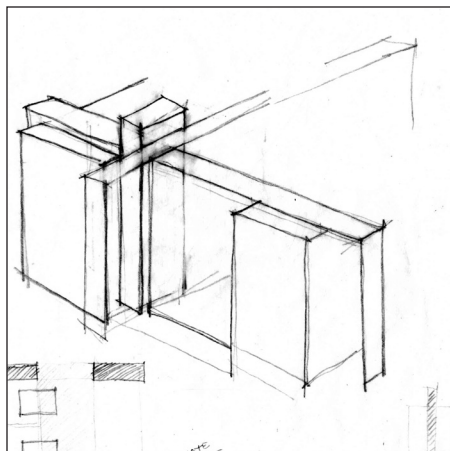
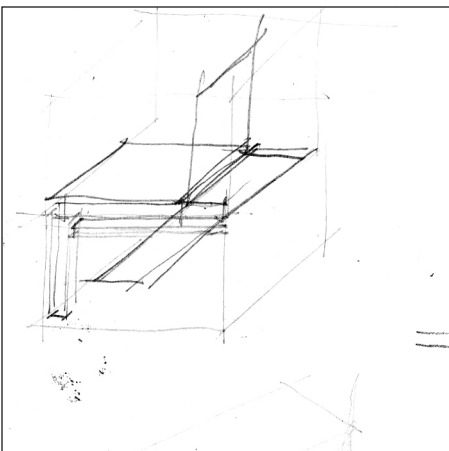
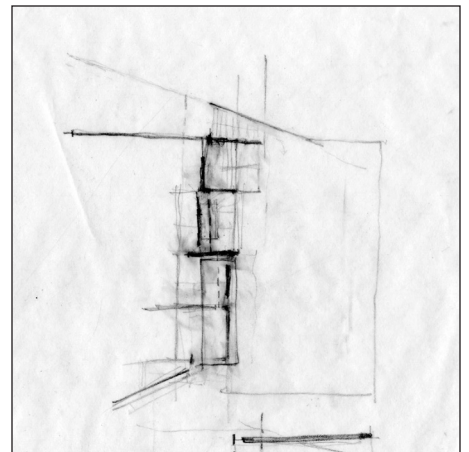
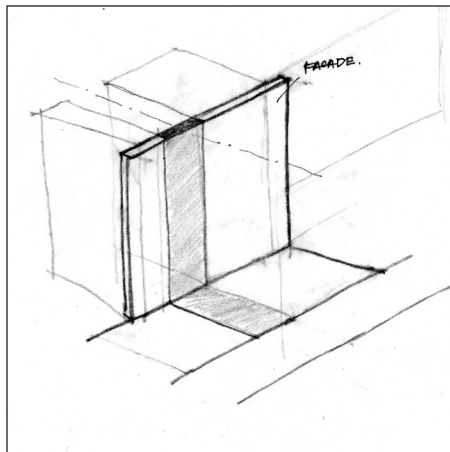
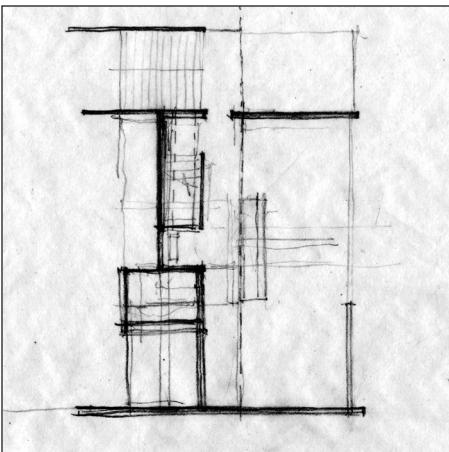
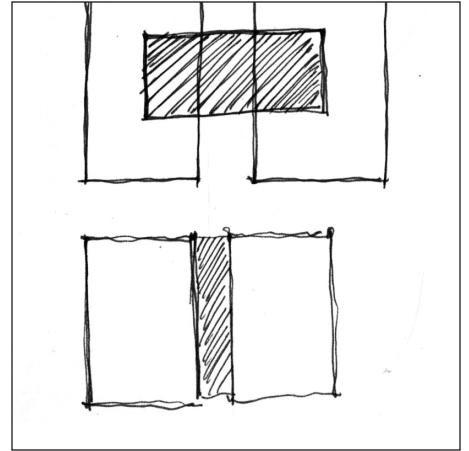
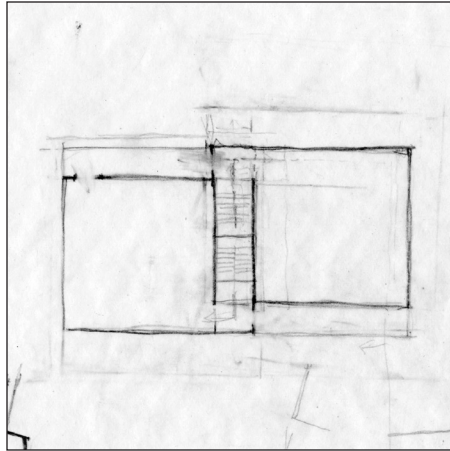
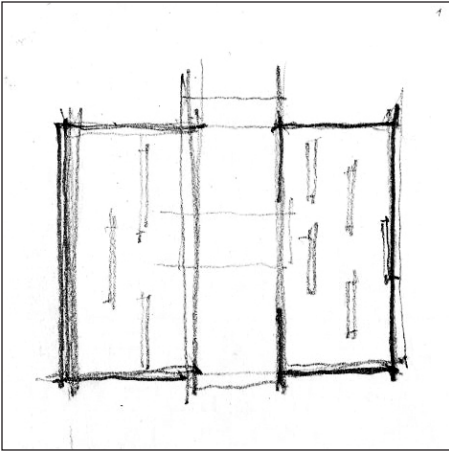

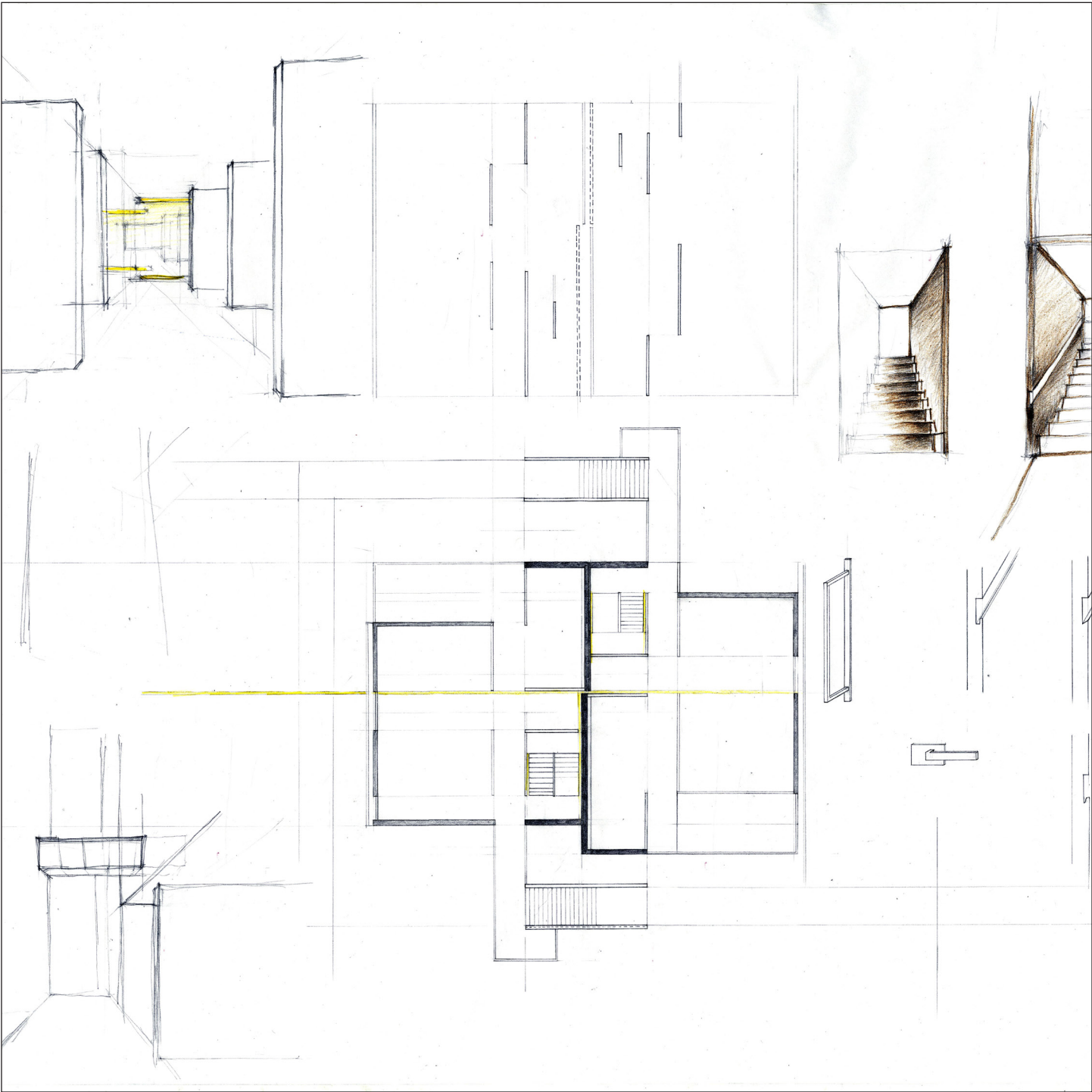

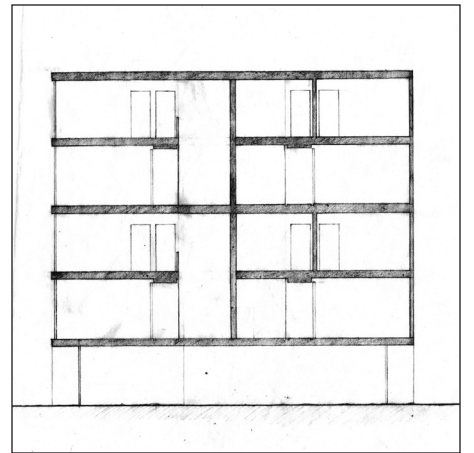
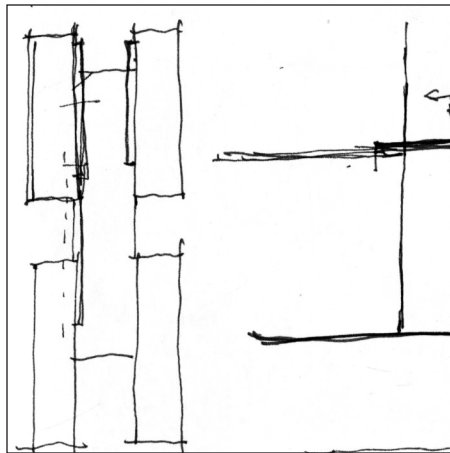
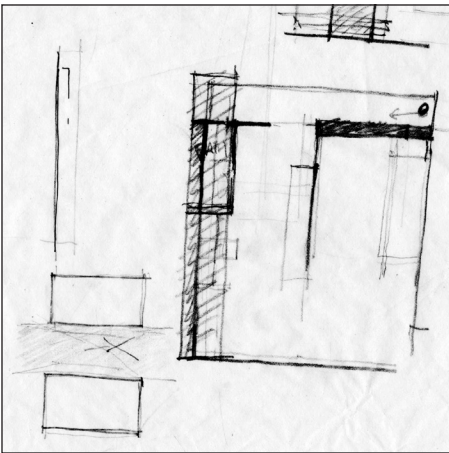
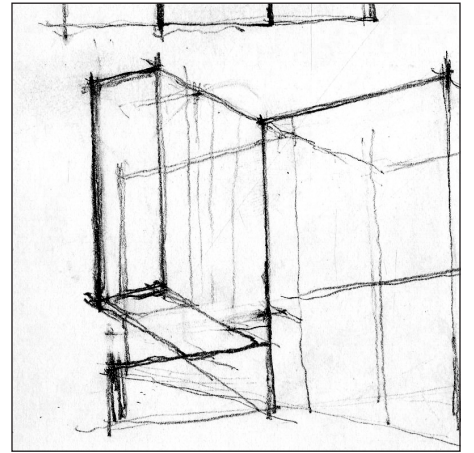
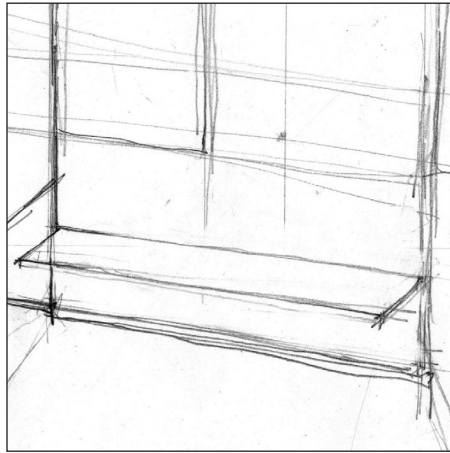
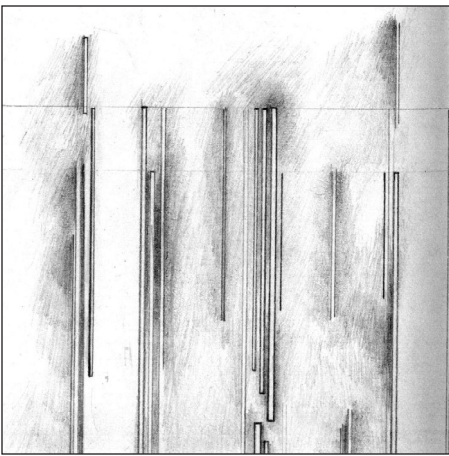
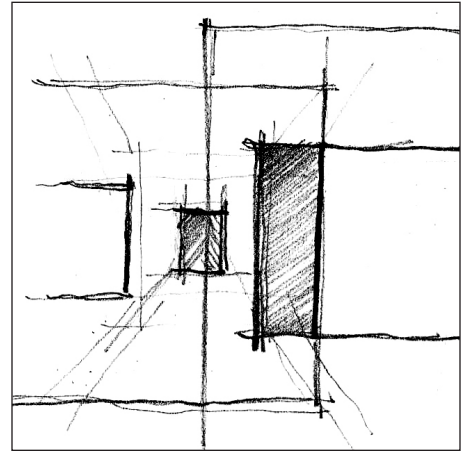
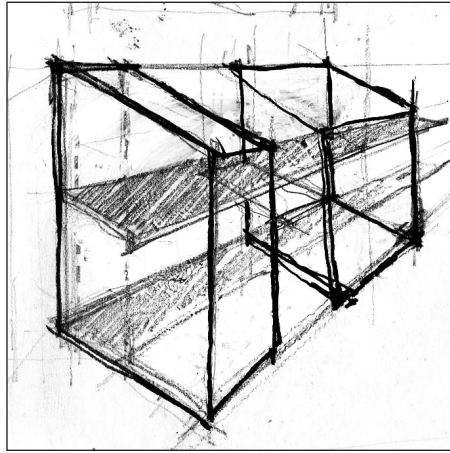
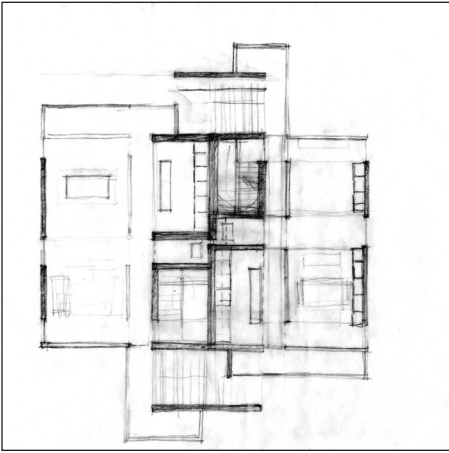



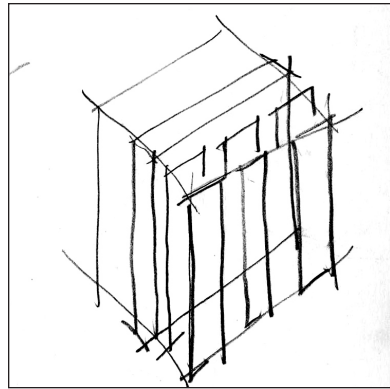
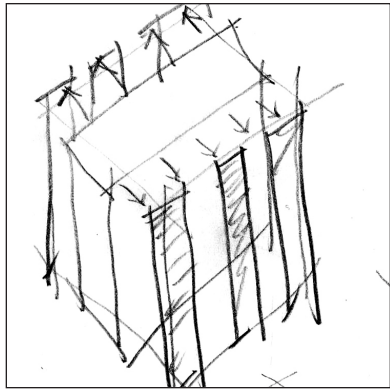
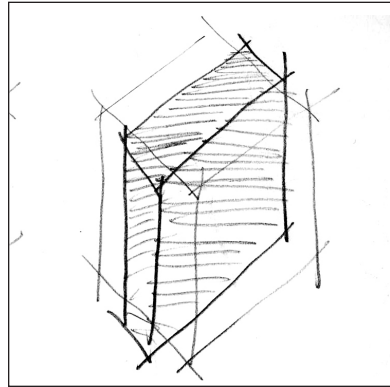
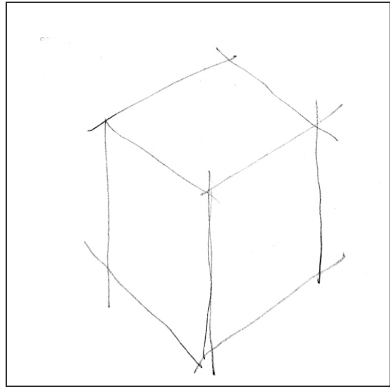

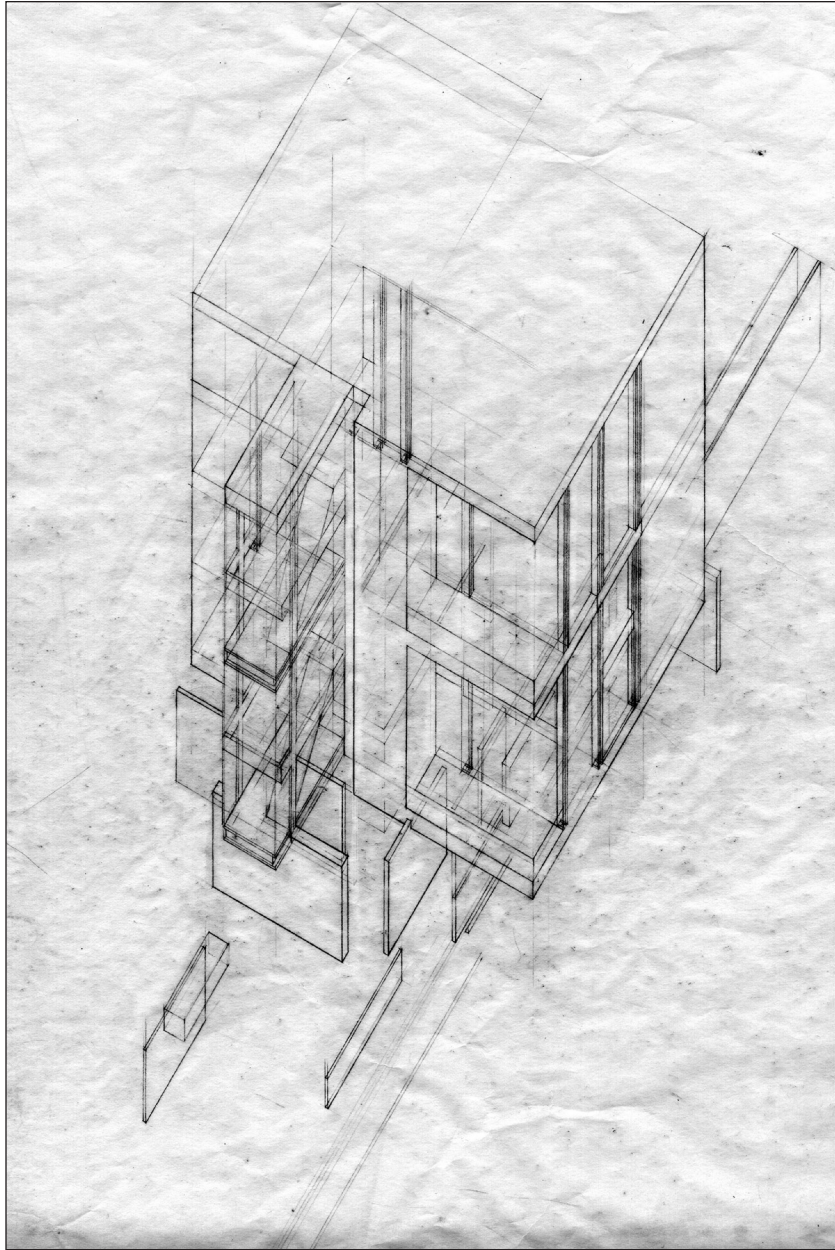

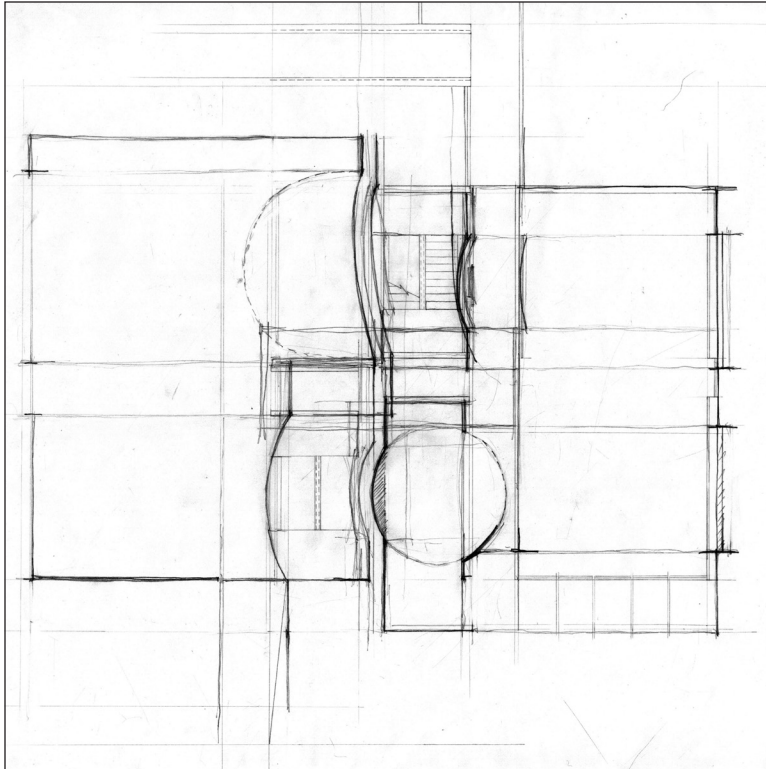

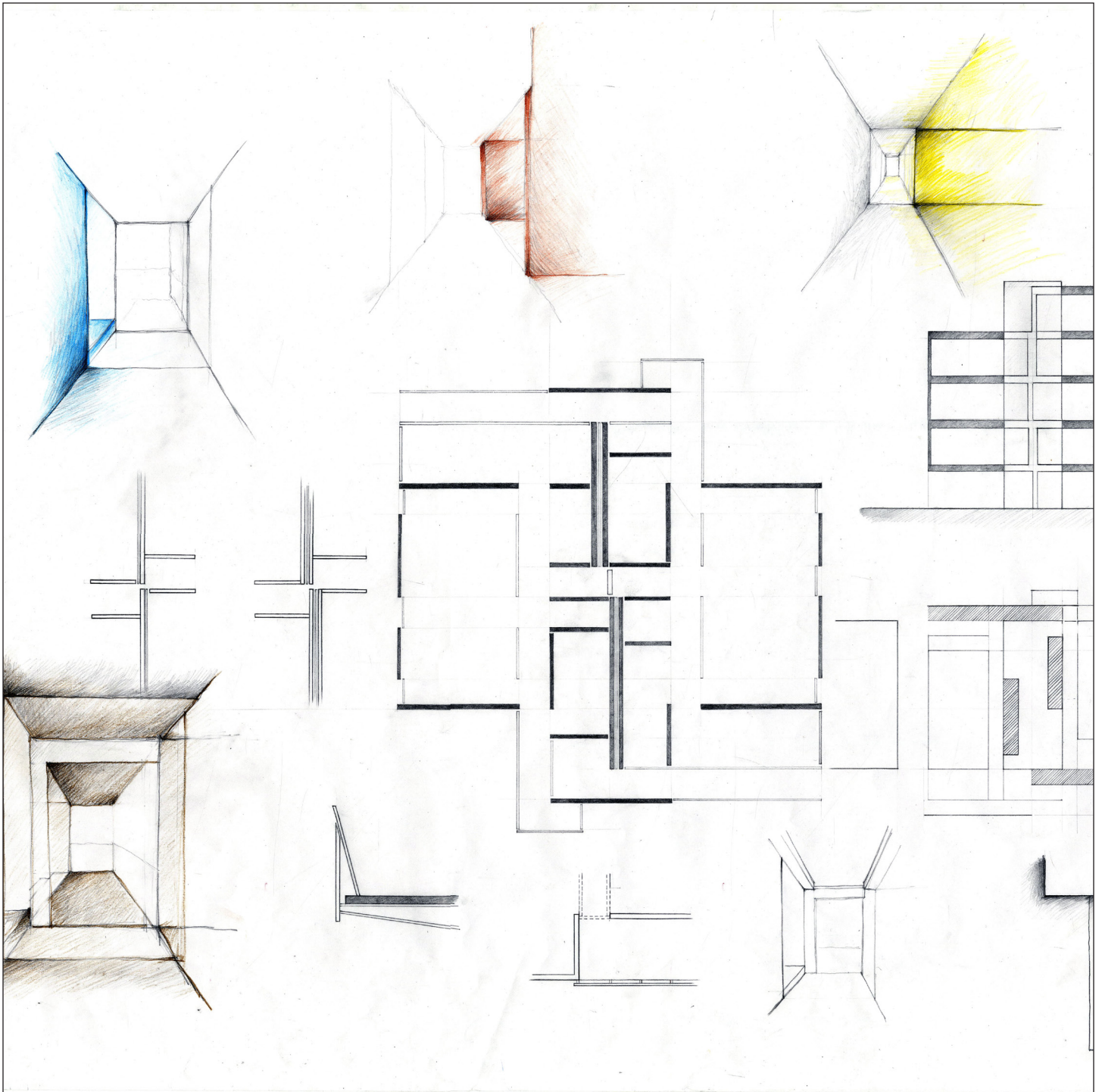

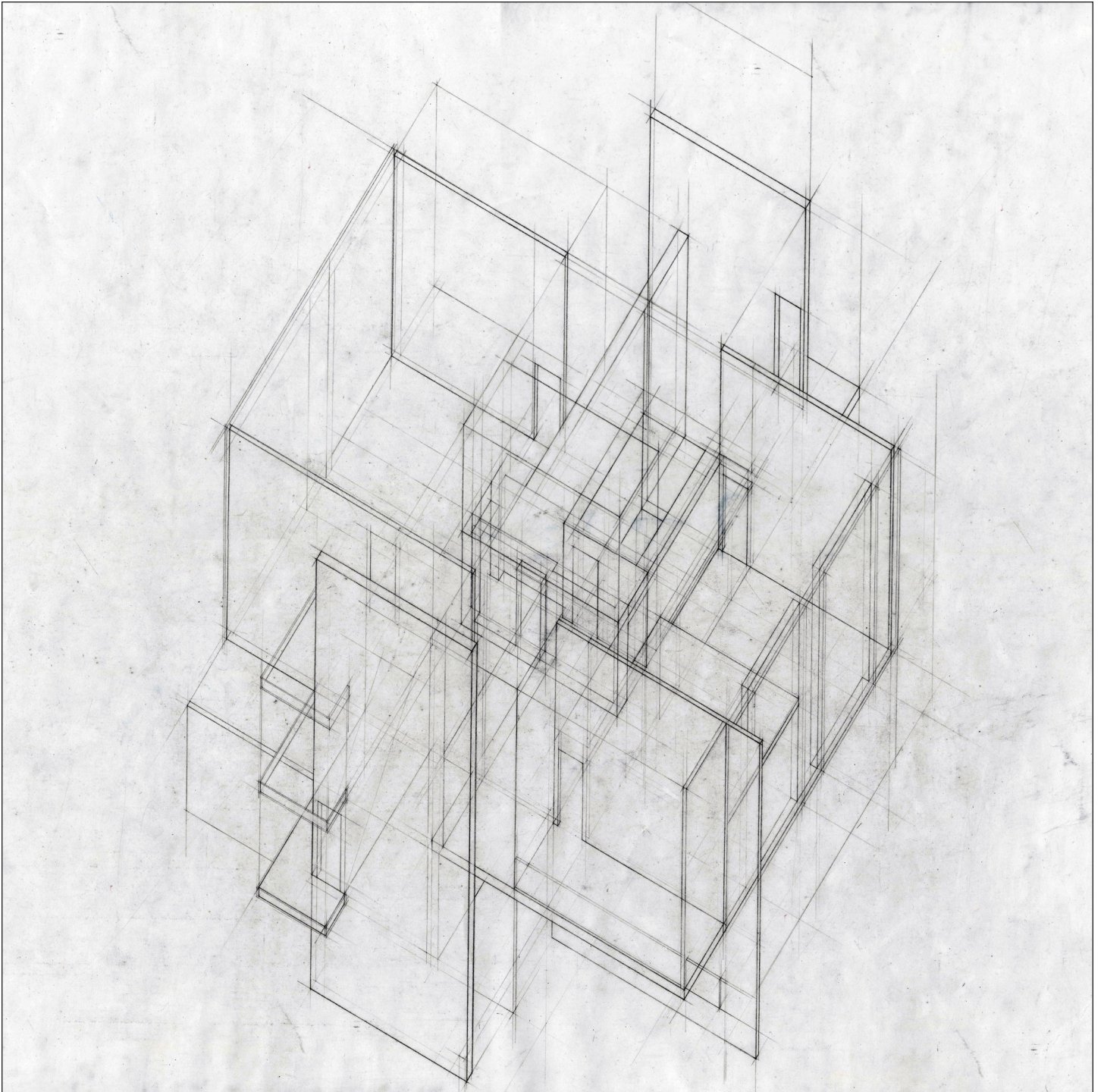

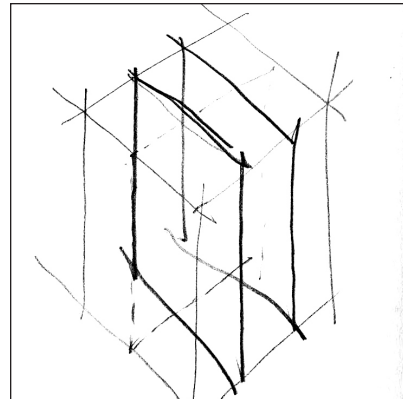
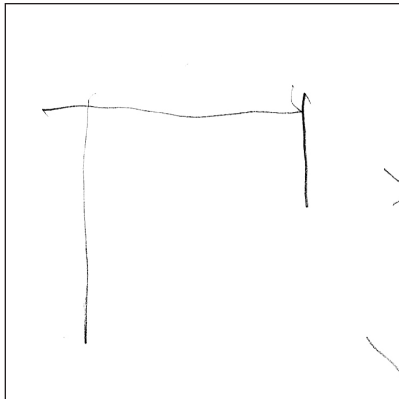
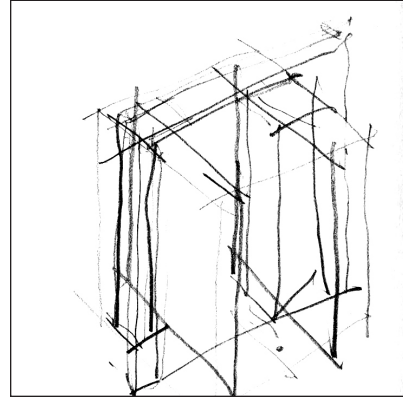
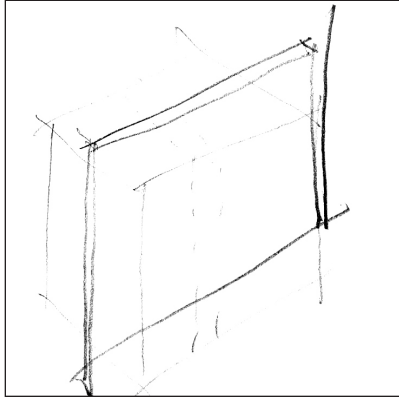

PAINTINGS

The paintings started off as an exercise of applying color to the walls to change emotion and senses. After having them put aside, I reviewed them again weeks later. Information, such as ideas of transparency and the treatment of corners, were discovered and fed back into the drawings and model.

The paintings are not the beginning of the thought process, but they indicate the beginning of this thesis, which started taking shape after understanding this architectural language I am using. The change of approach in these paintings reflected the change in my thoughts and its phases.

These paintings are a pause and a reflection of the architectural drawings. They are the moments in which I stopped thinking, and acted upon imaginations.



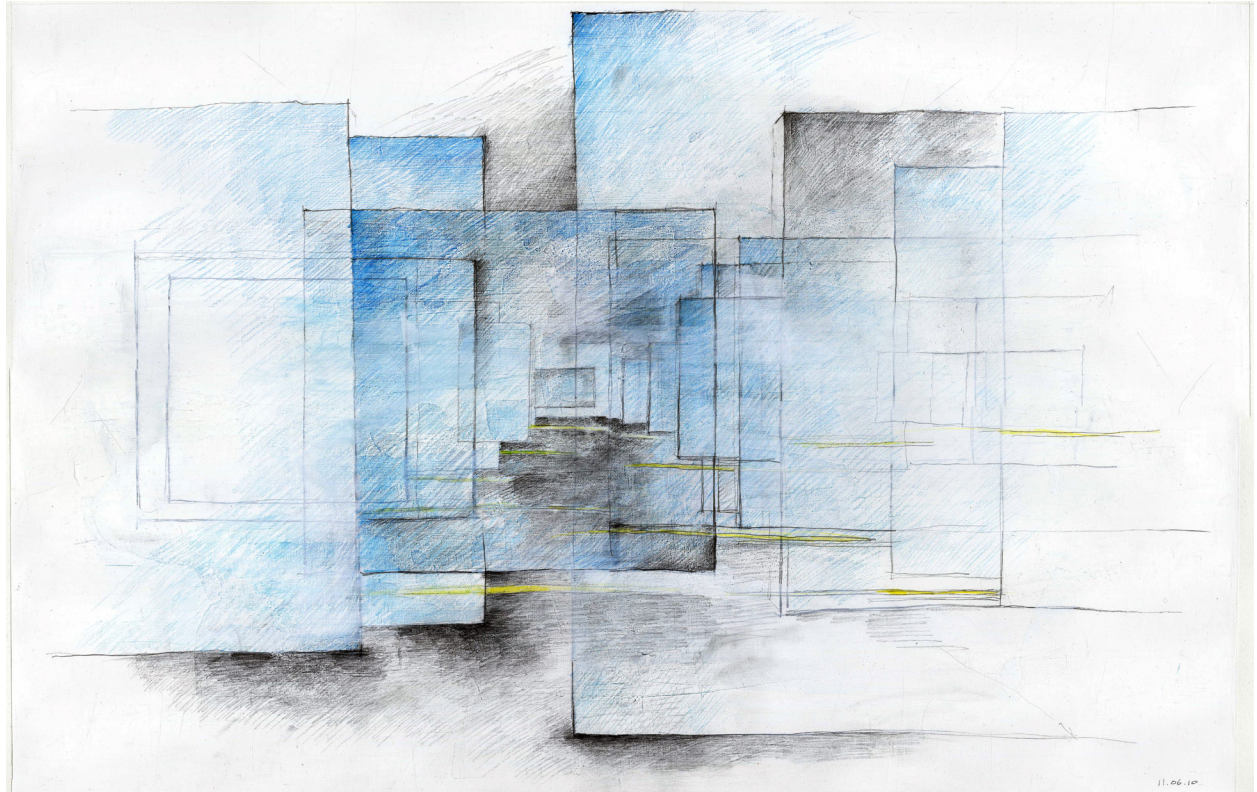

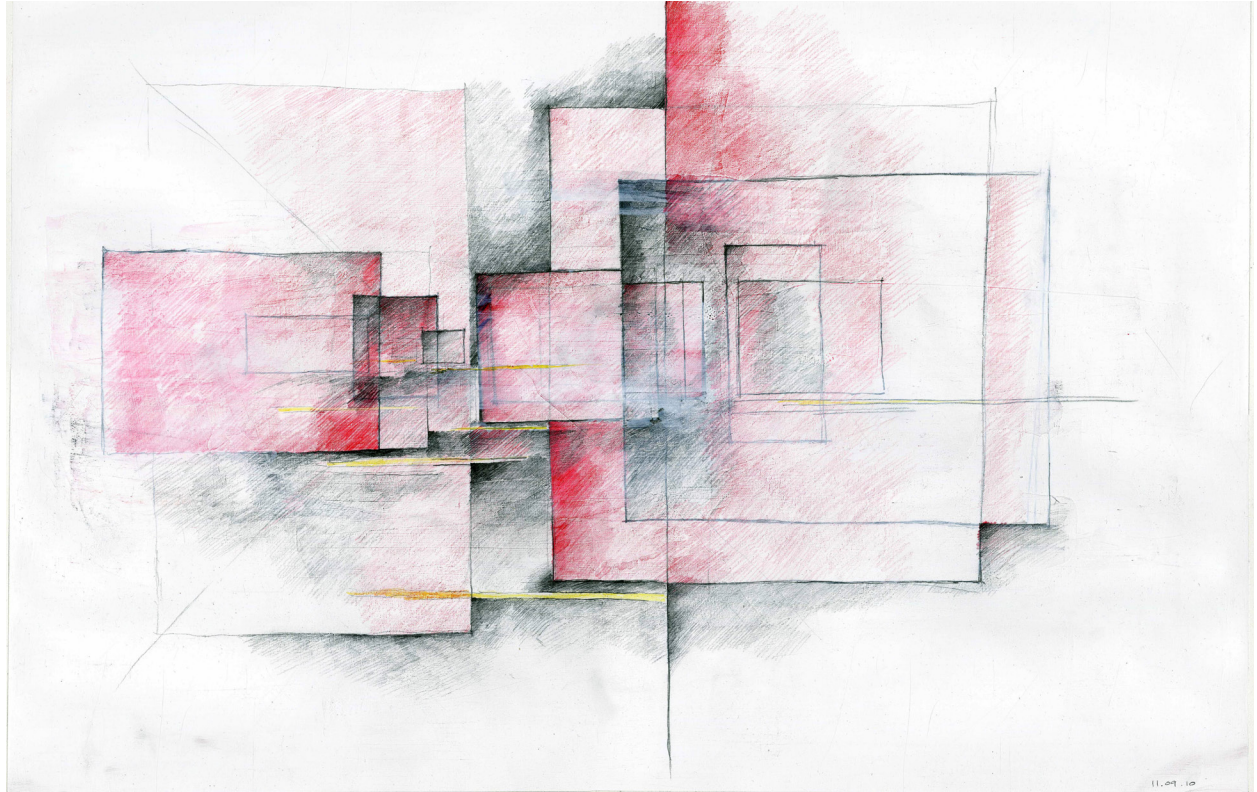

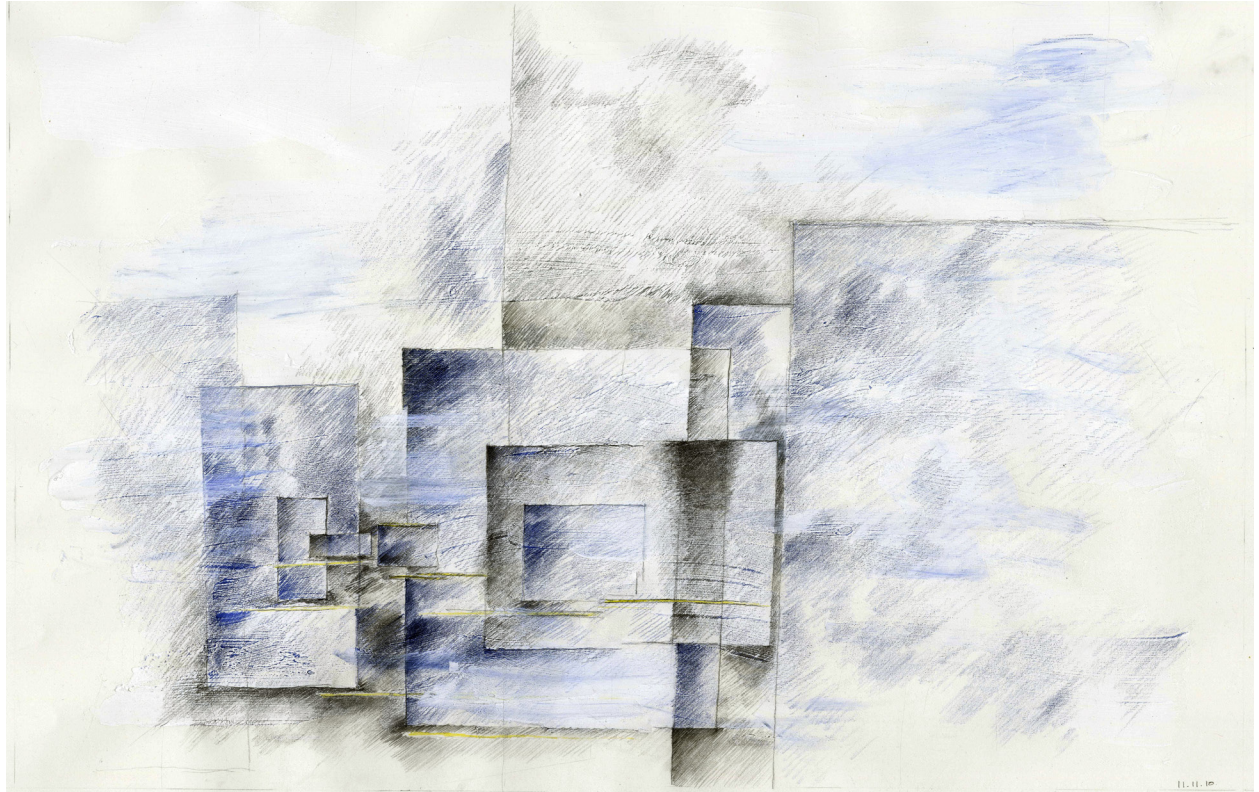

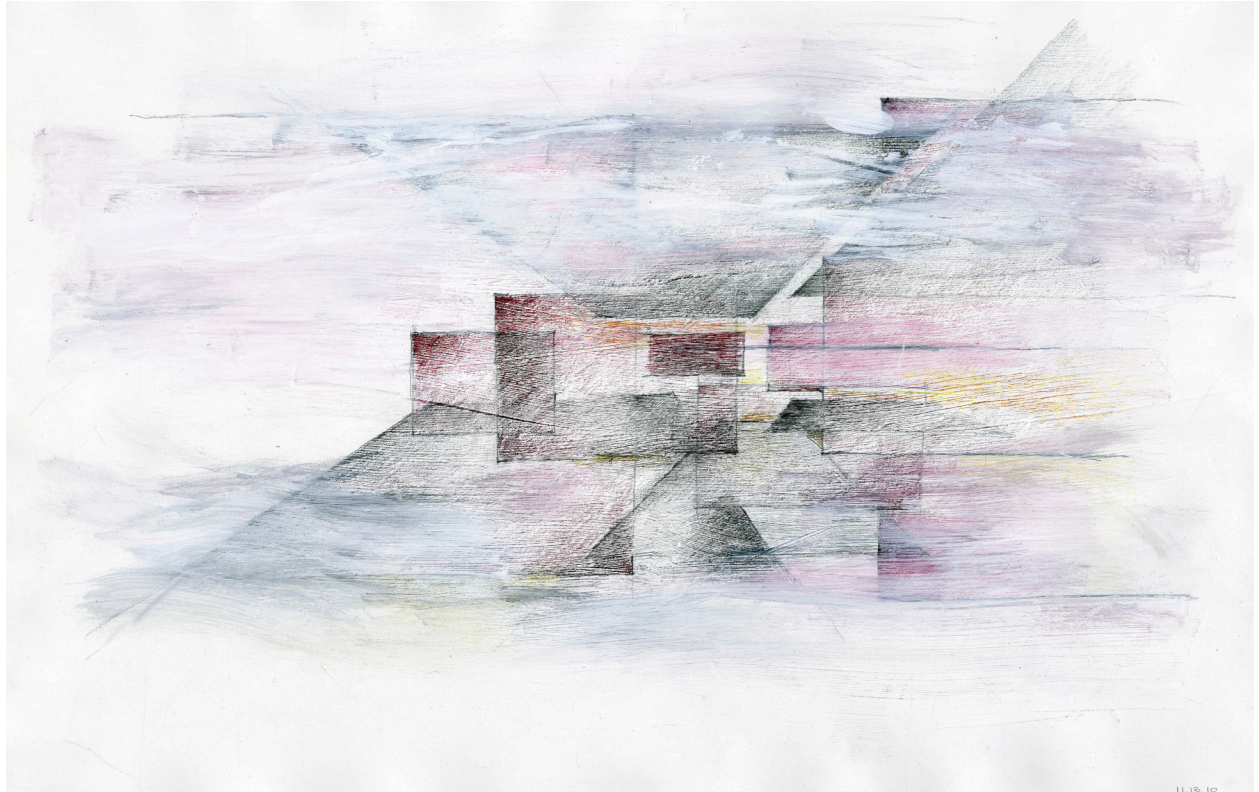

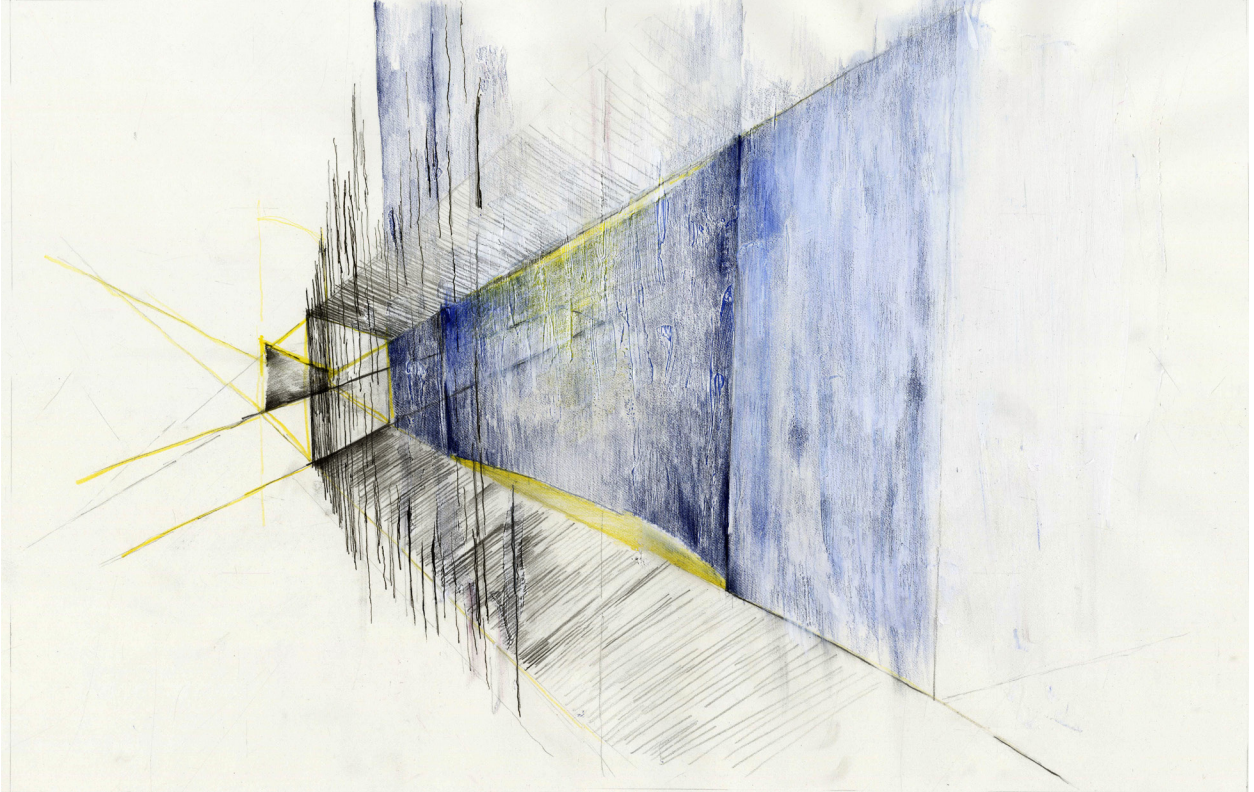



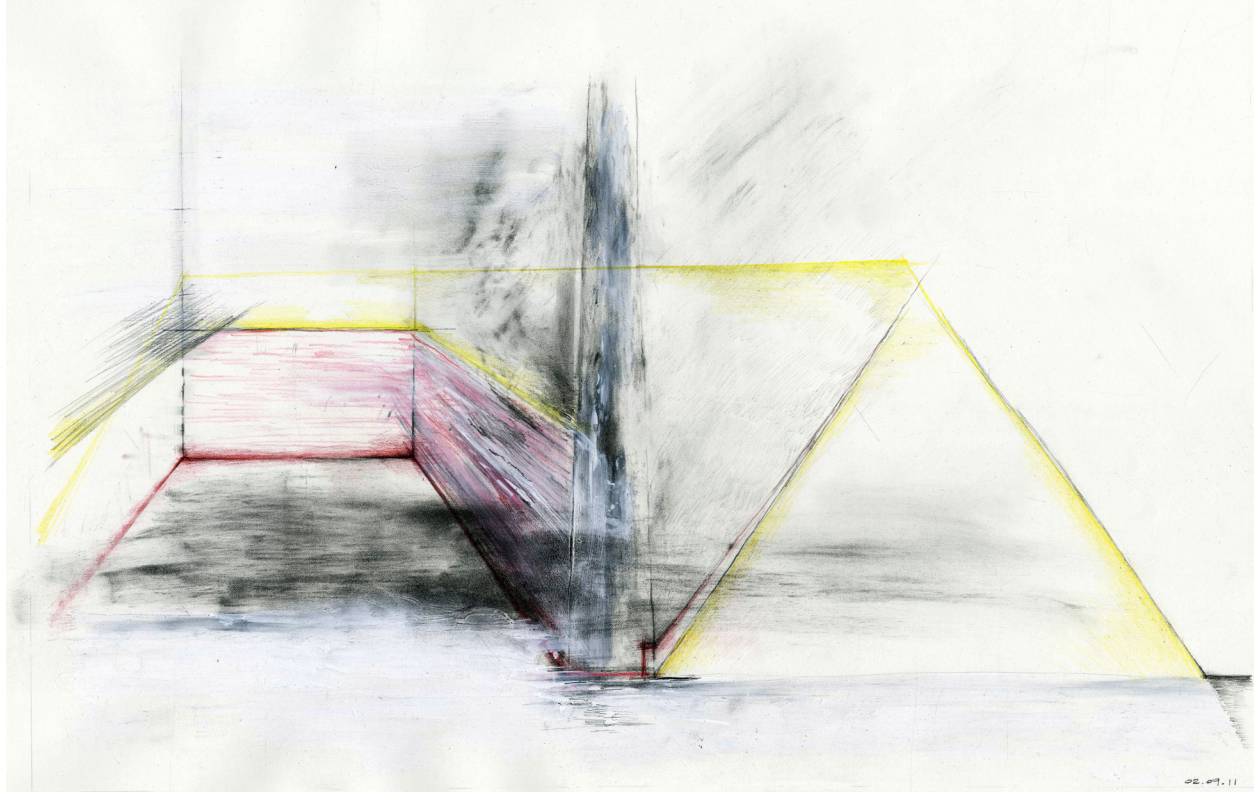



02.19.11



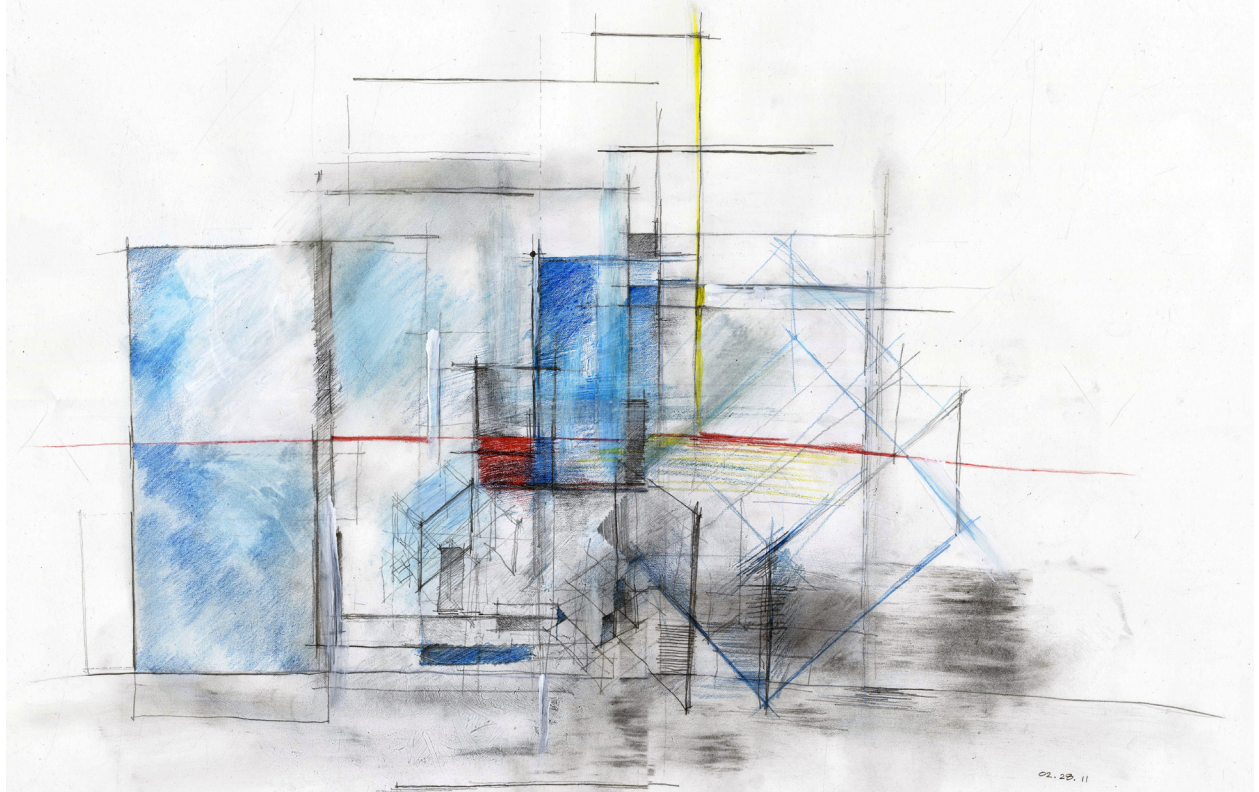

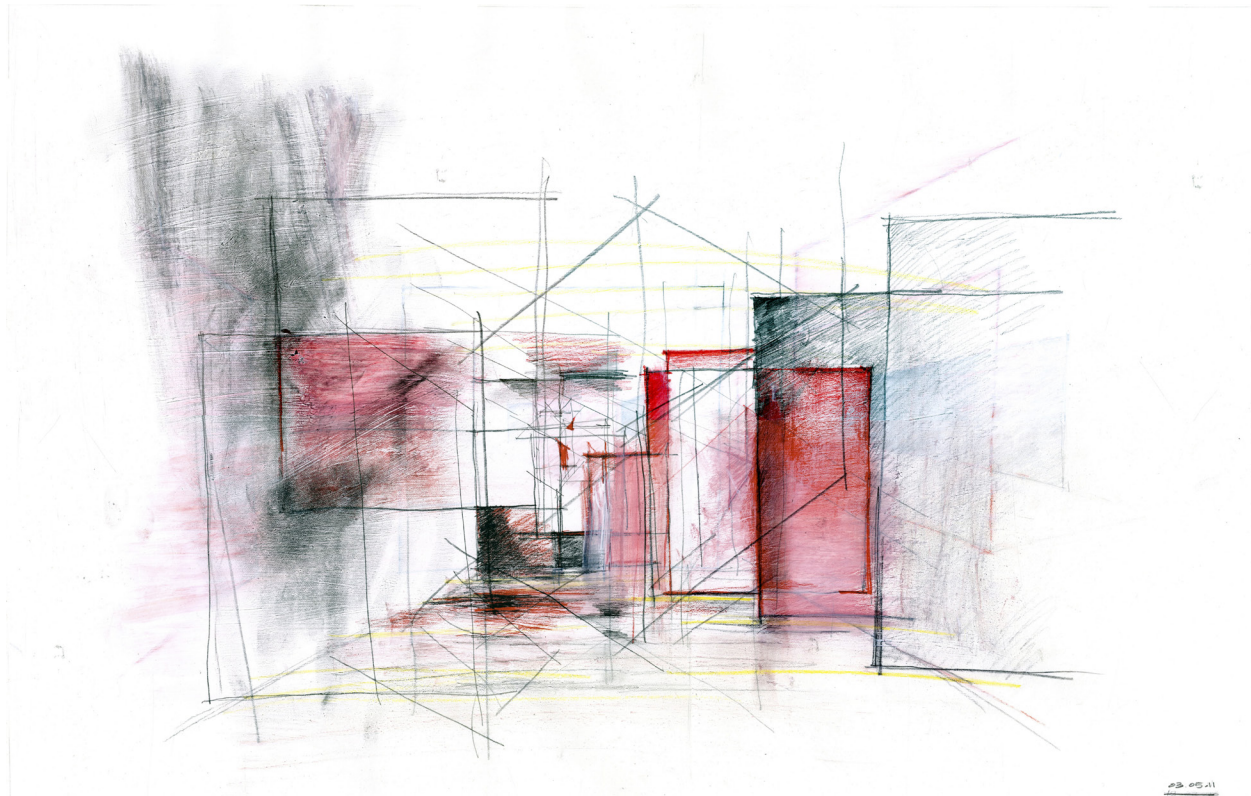

23 05 11



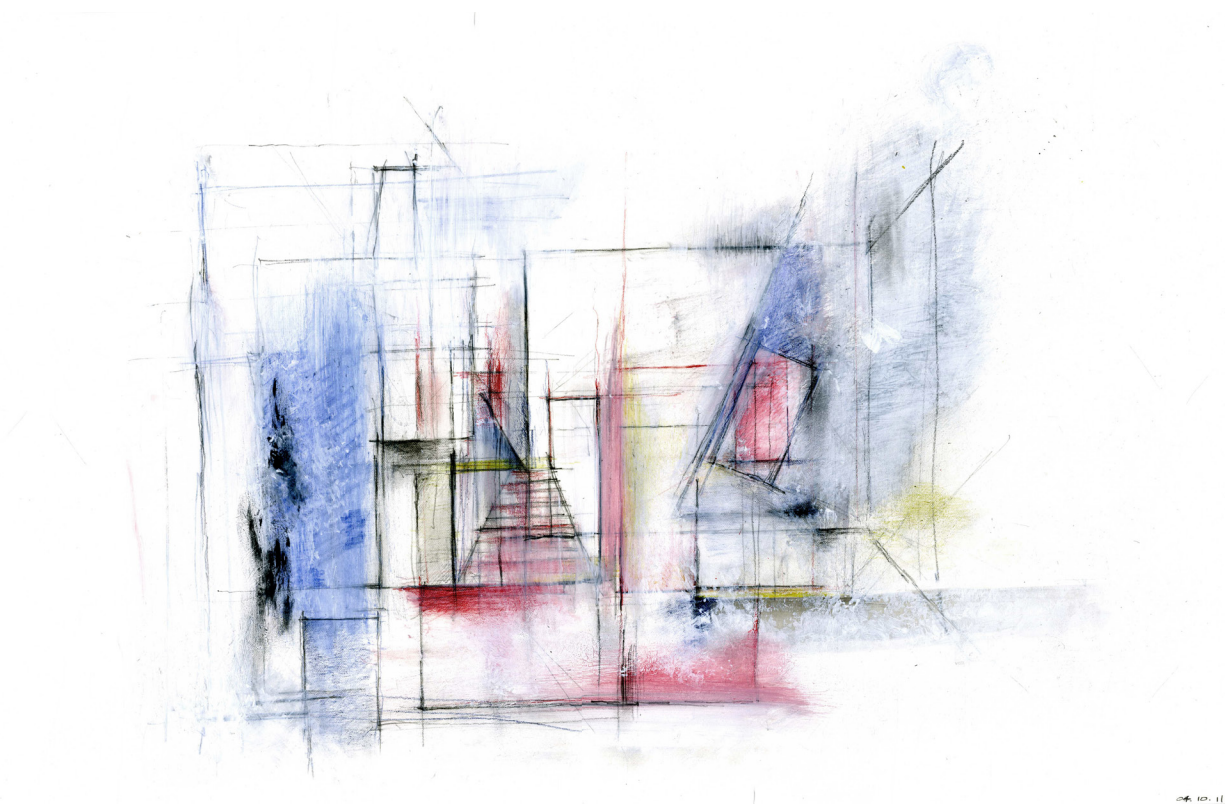

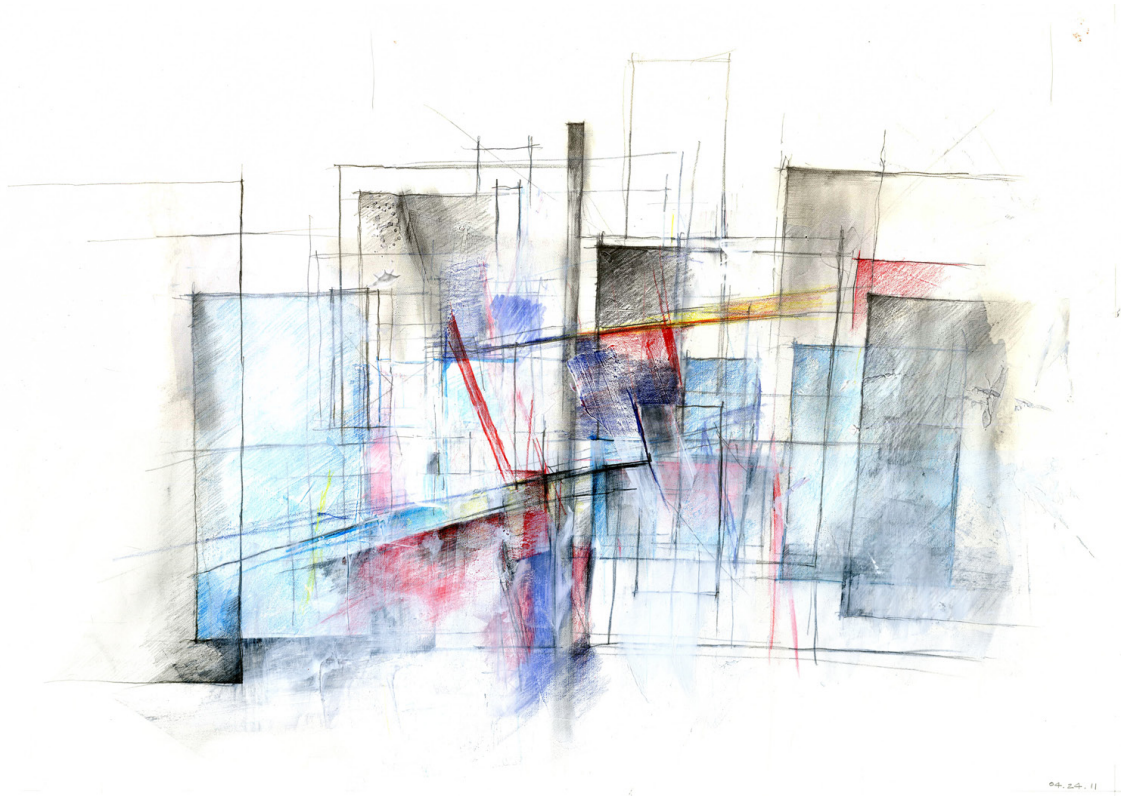

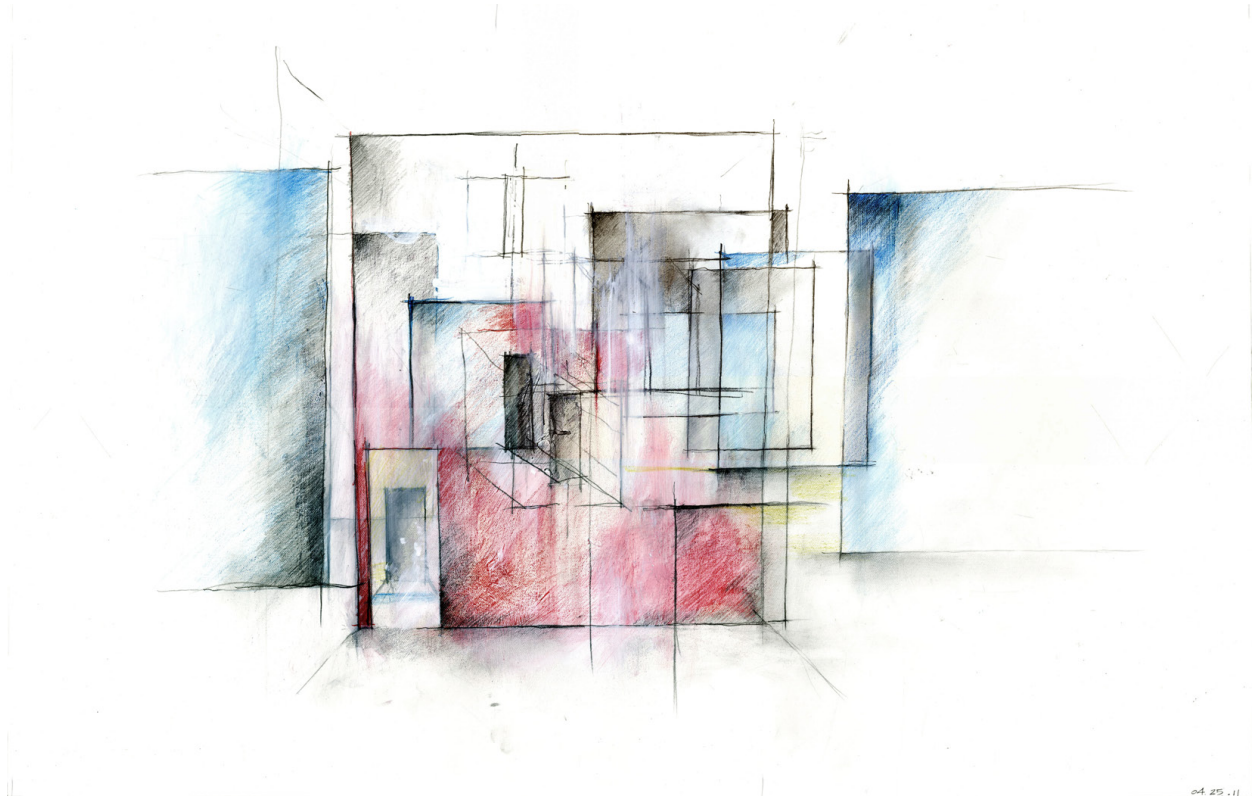

04.25.11

DRAWINGS

Throughout the house the characteristics of transparency are expressed by contradiction of spatial dimension. A thin wall is pulled away from the central thick wall; the void created by the two walls opposes the ambiguity of scale of the staircase. The reality of deep space (staircase) is opposed to the inference of shallow space (hallway). Crossing the entry into the unit, the foyer separates the living room and the dining room; this separation enlarges the spatial differences of the living room double space and the heaviness of the bedroom presses against the dining room.

A freestanding wall surface, which extends at the living room double height space, is equal in height to the glazing. The layering of surface creates a surface tension. Transparency is achieved not through the direct use of transparent material but rather through bringing to consciousness the interpenetration of two surfaces without their mutual destruction.

The layers of space of the recessed ground floor and the exterior staircase emphasize the continuous dialectic between centralized, volumetric forms and linear, planar conditions.



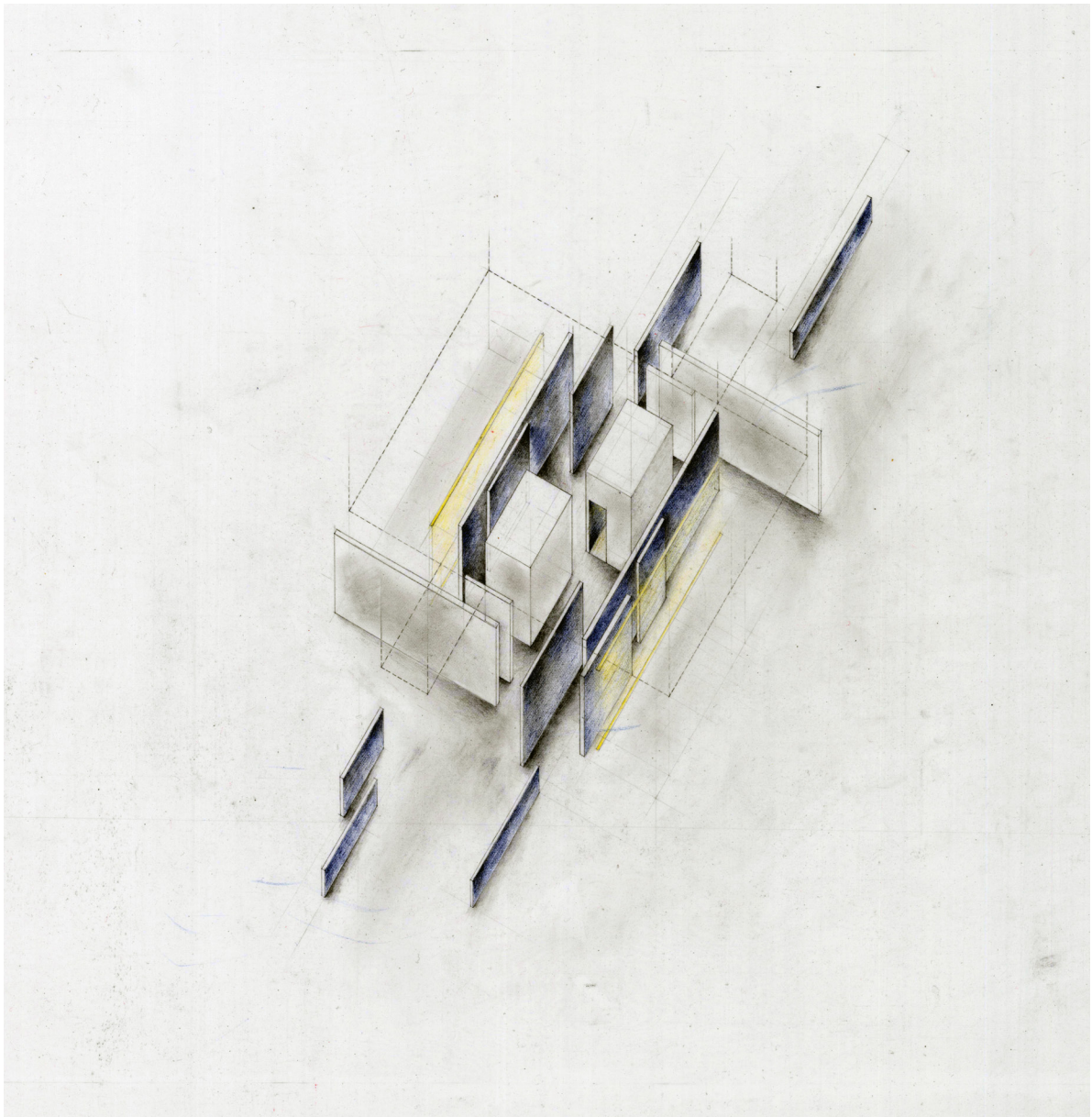

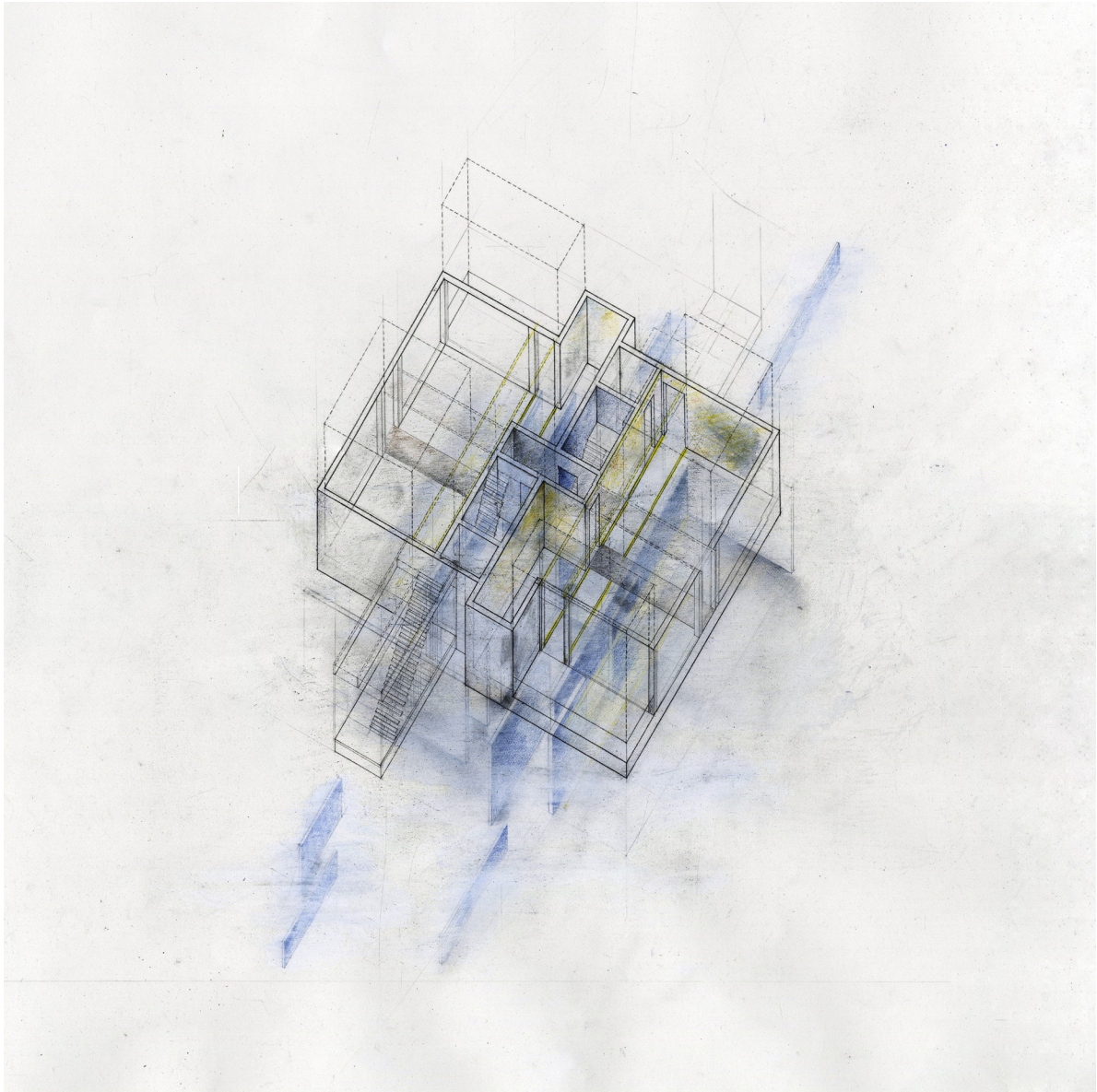

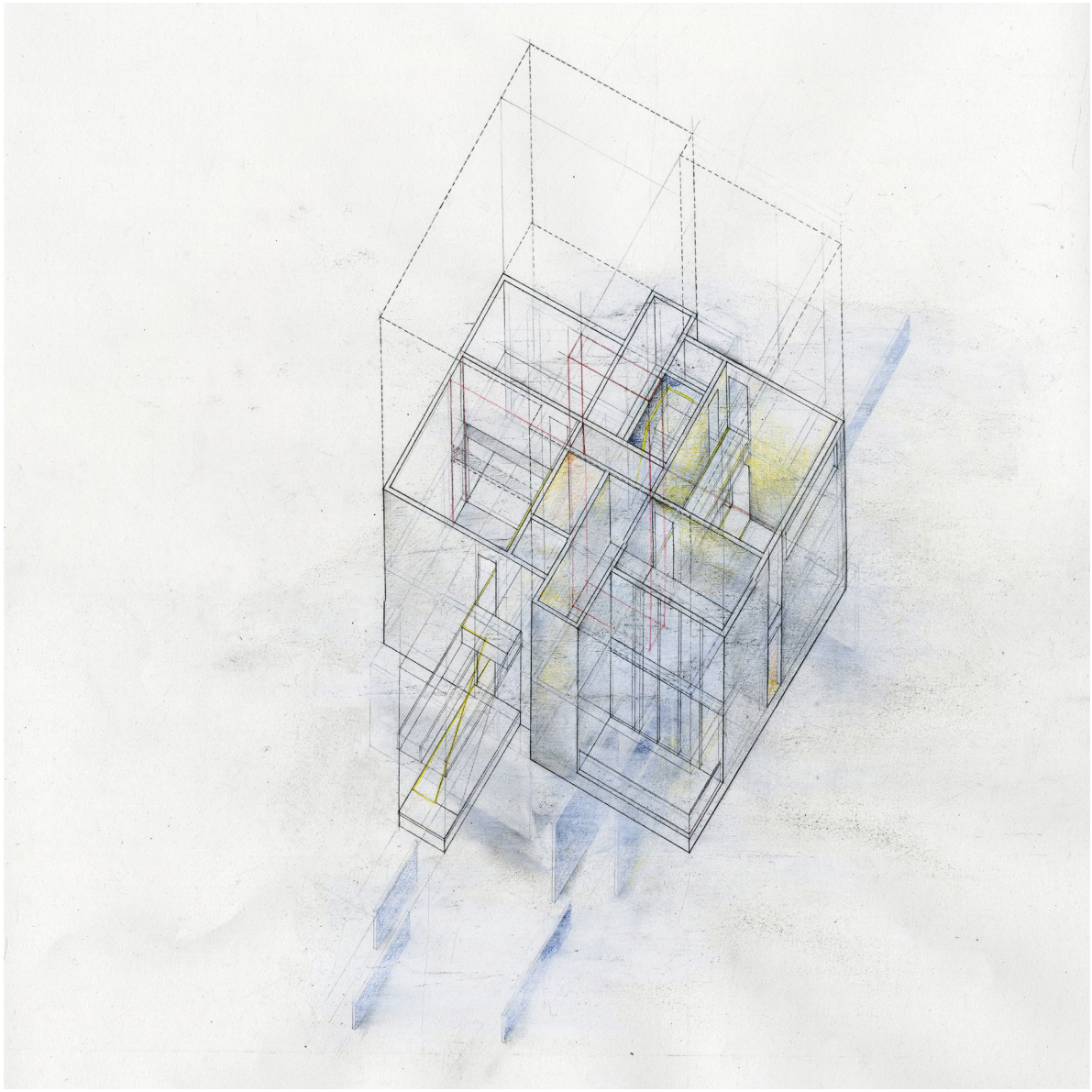

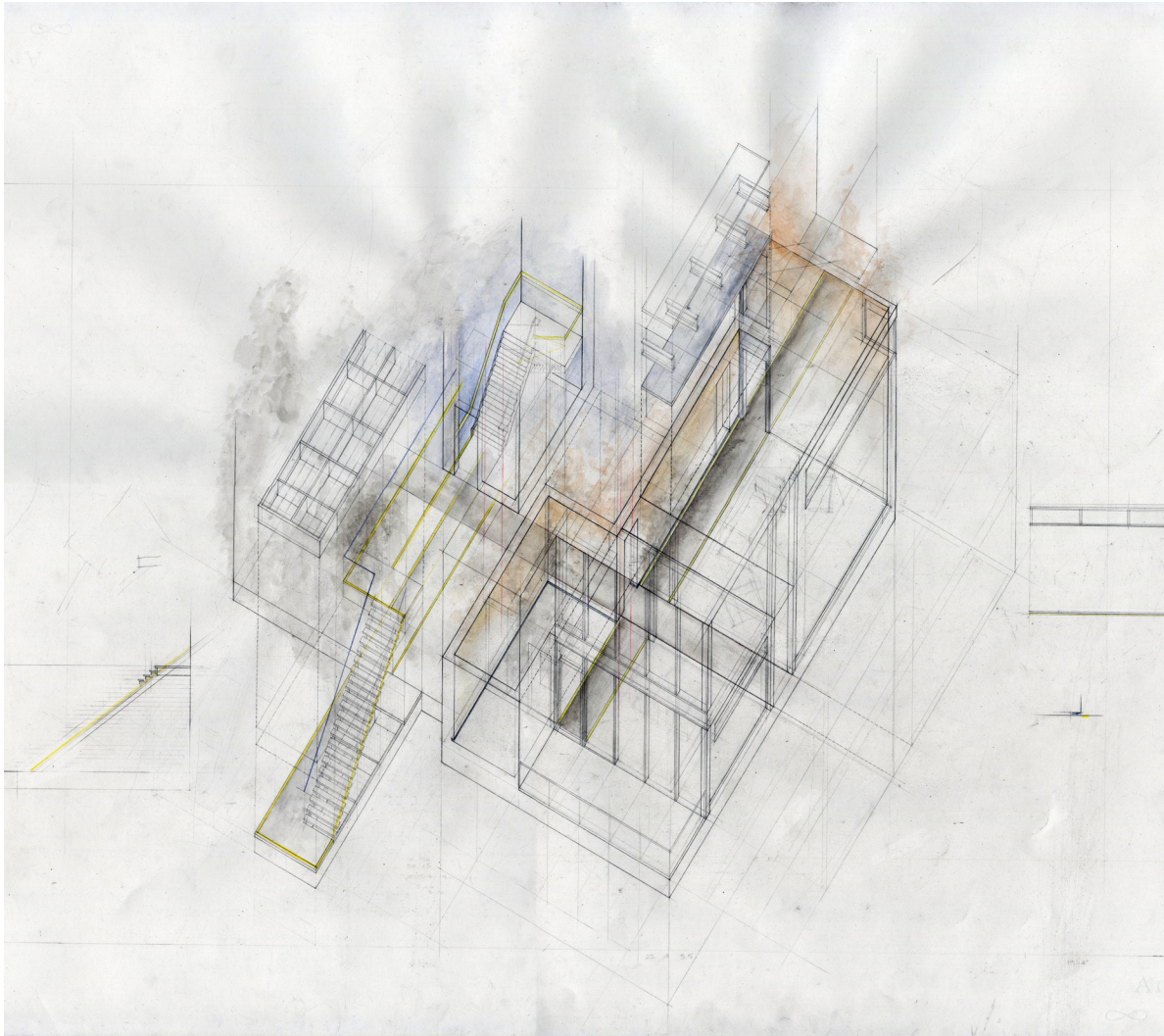

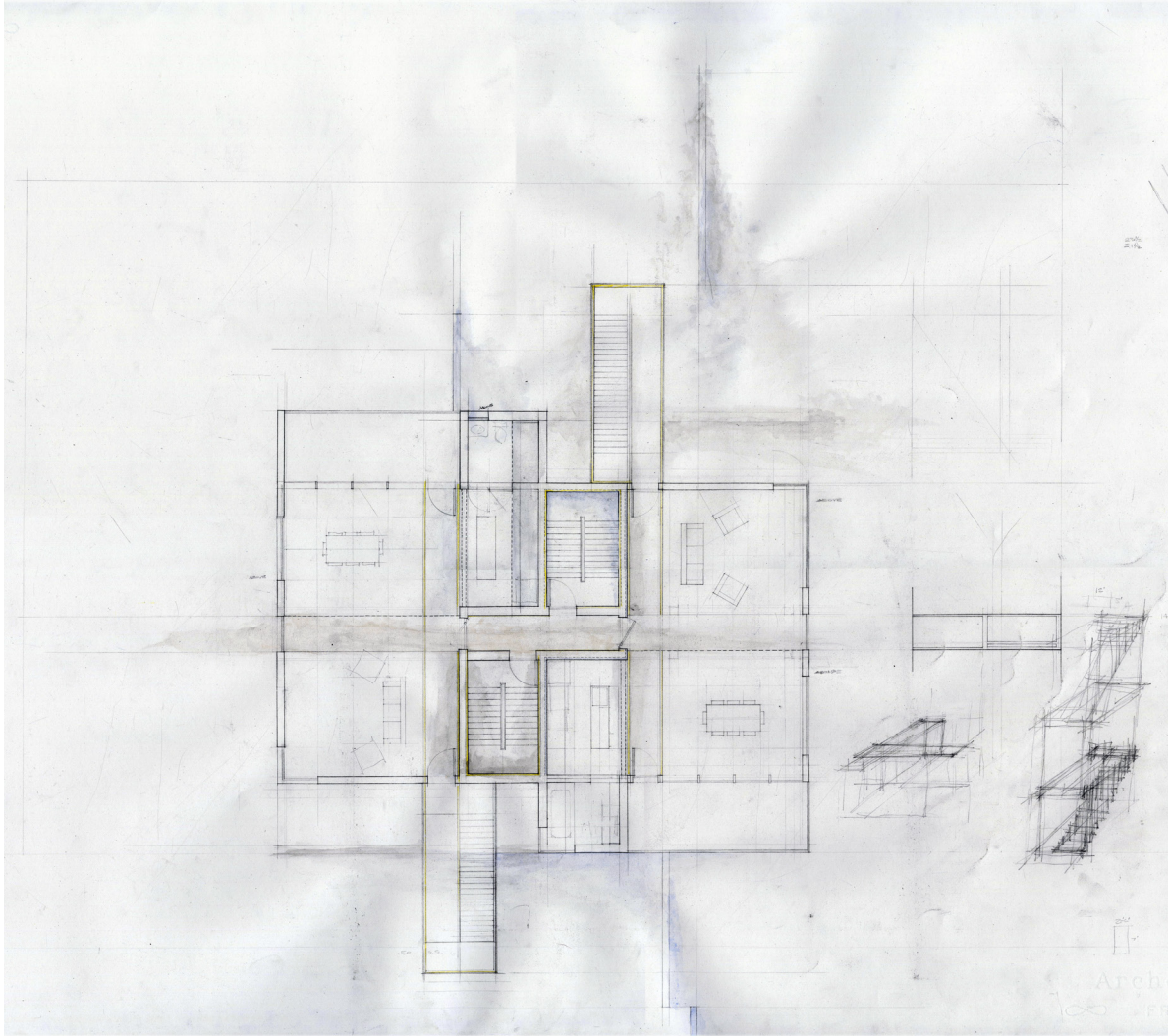

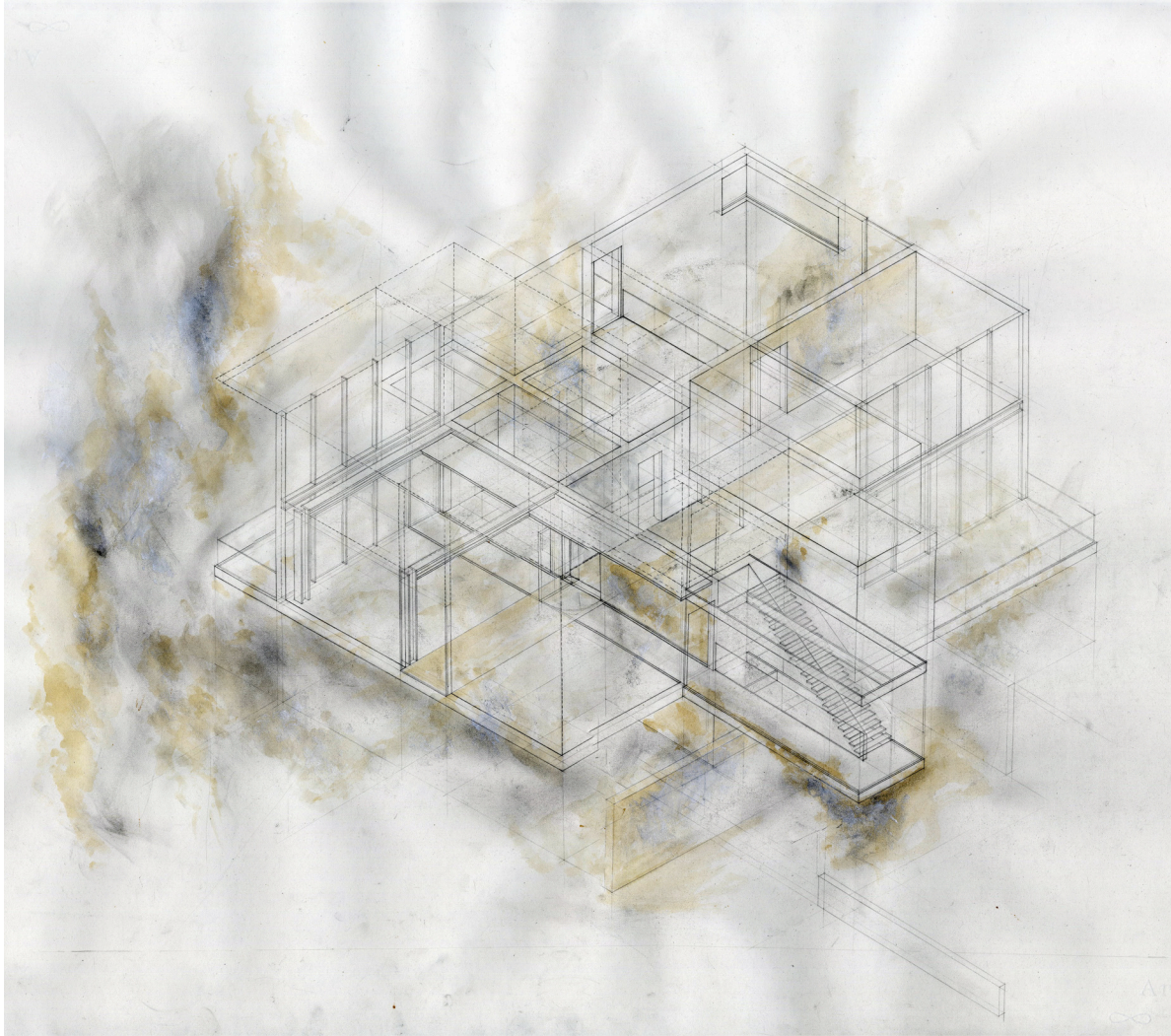

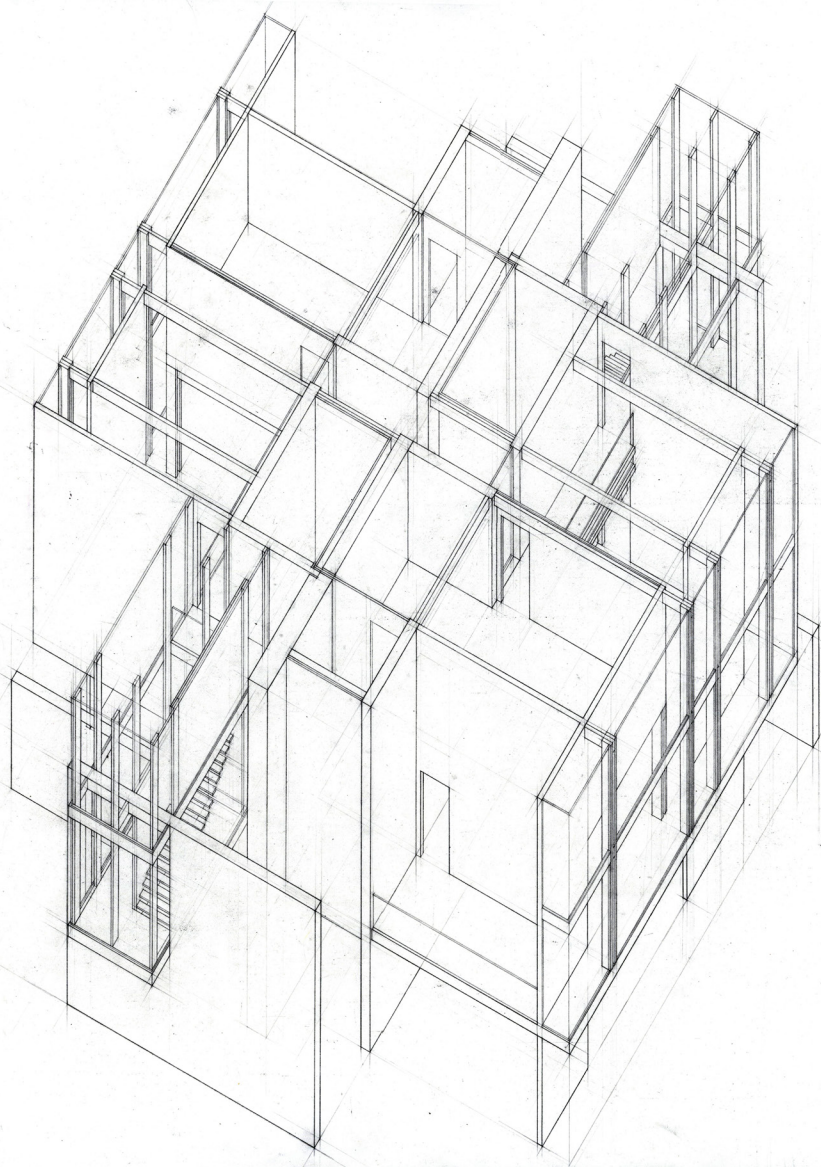

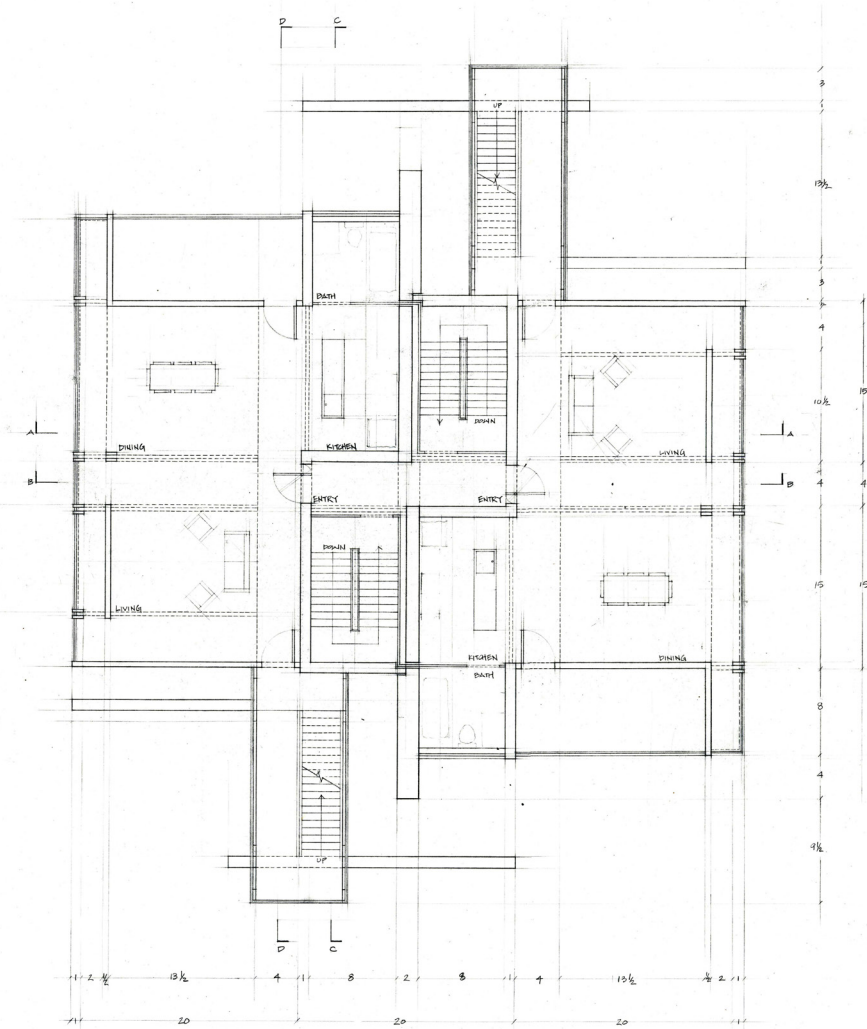



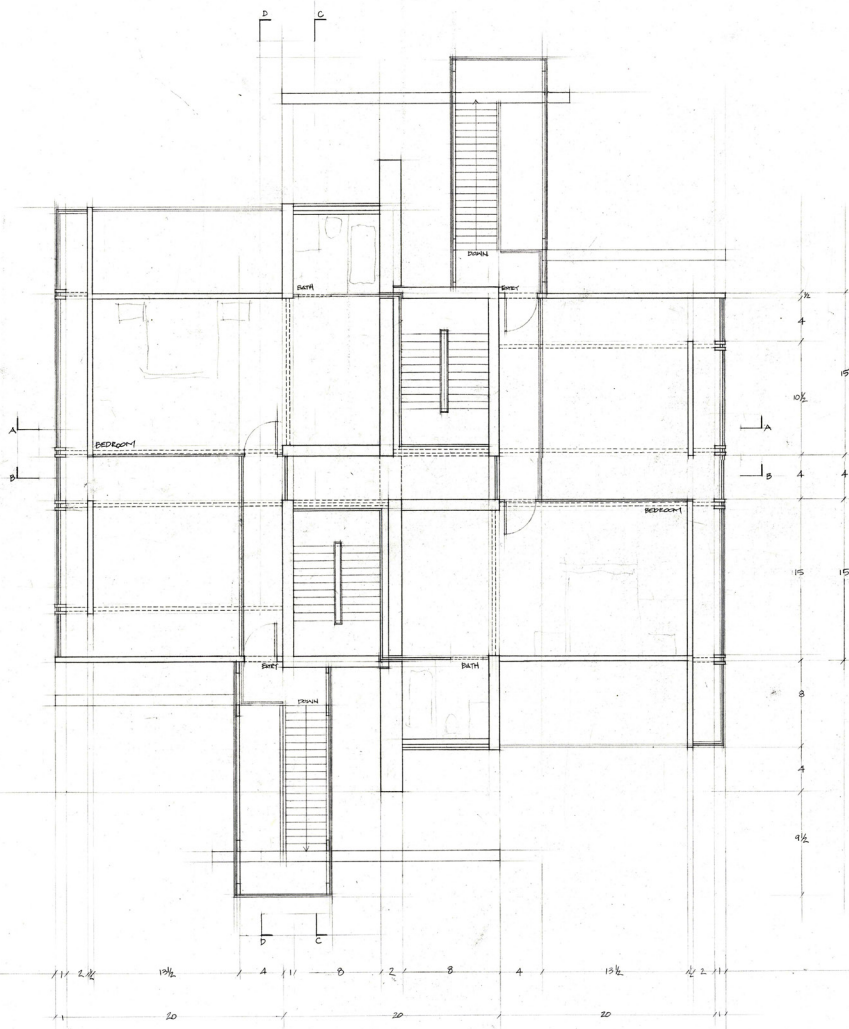

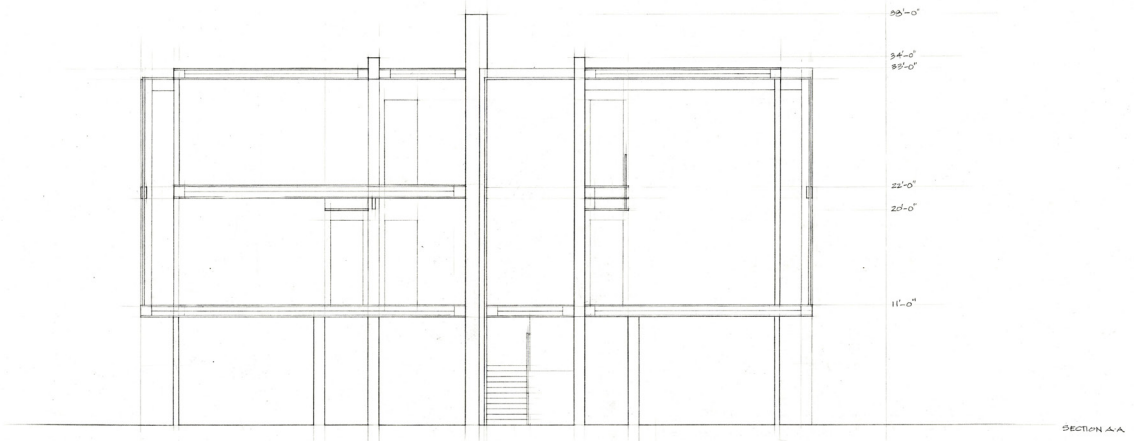

SECTION A-A

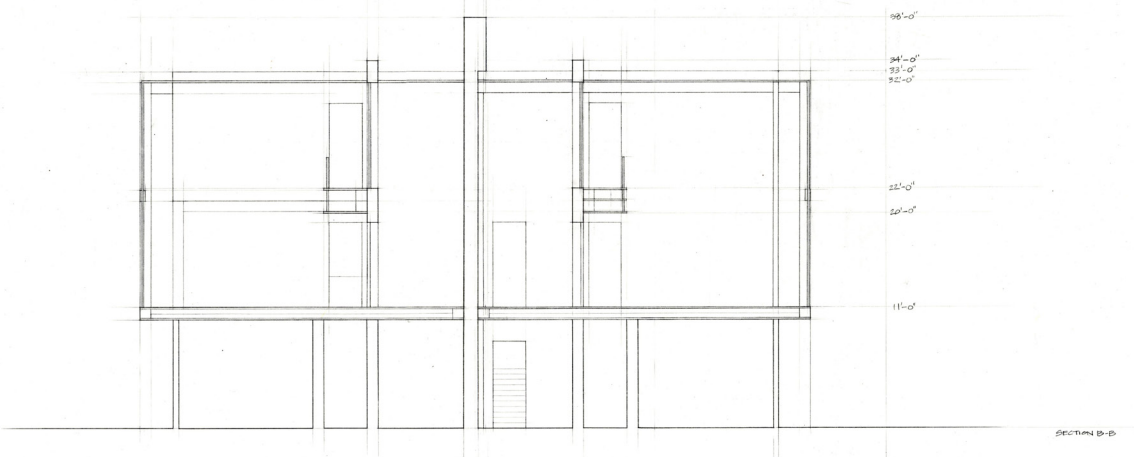

SECTION B-B

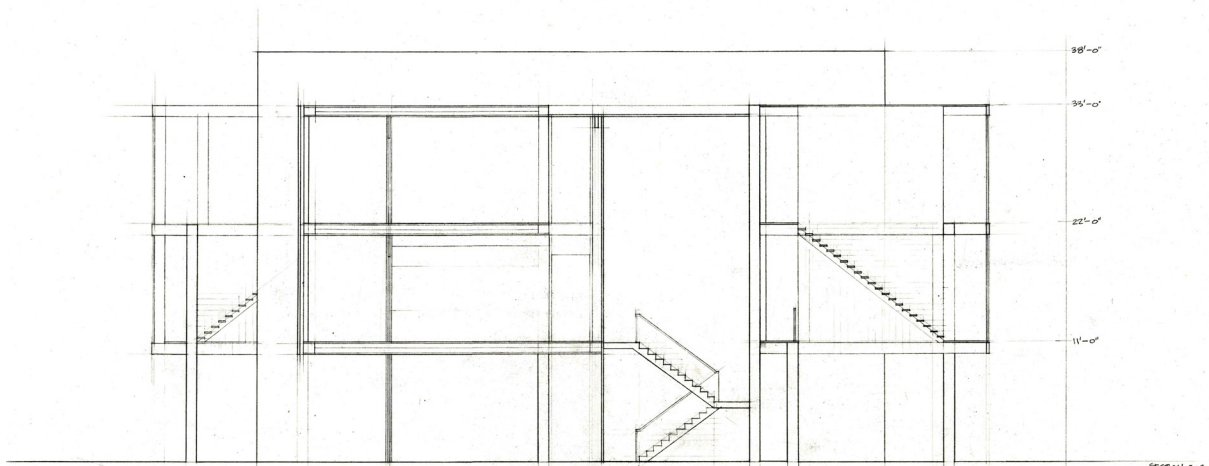

SECTION C-C

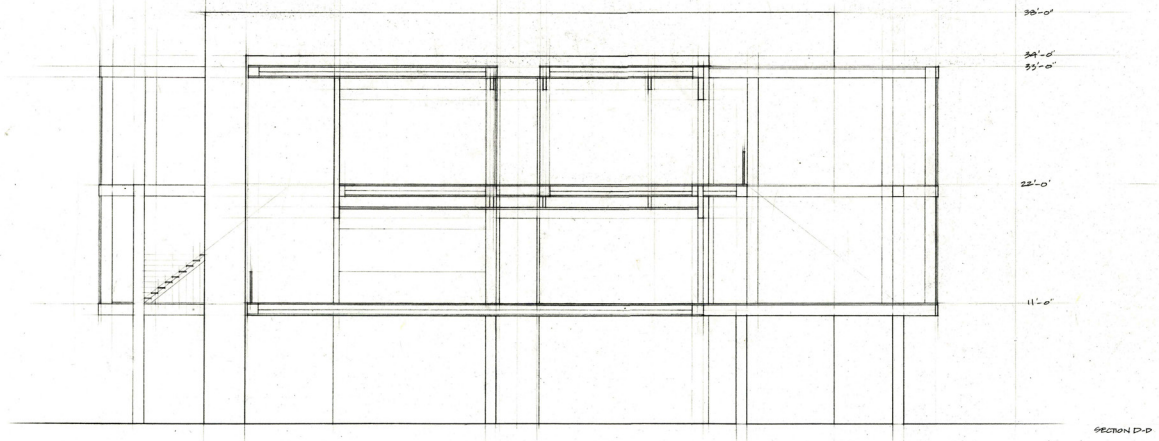

SECTION D-D

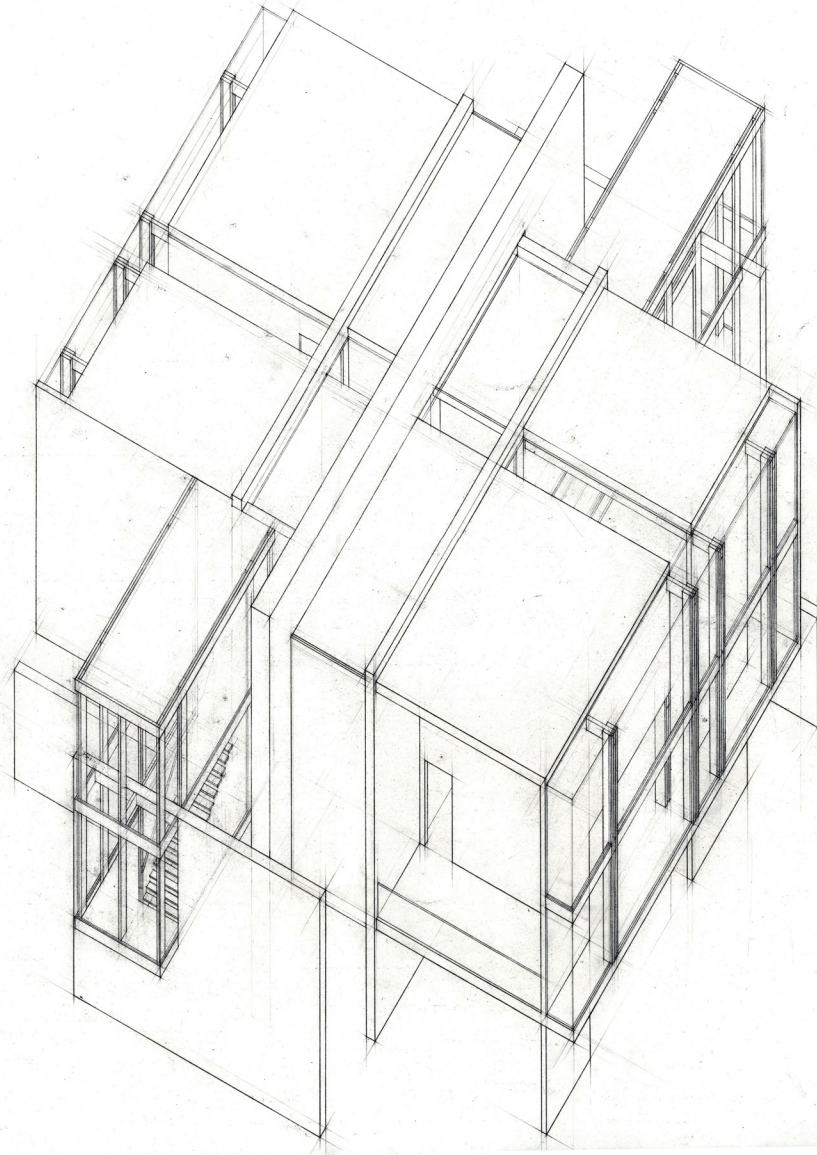

MODELS

These photographs indicated the shift from treating color as surface treatment to idealized light as a quasi-material.

Spatial orders and conditions are examined through the use of idealized color. The “dematerialization” of the building is expressed in the model.

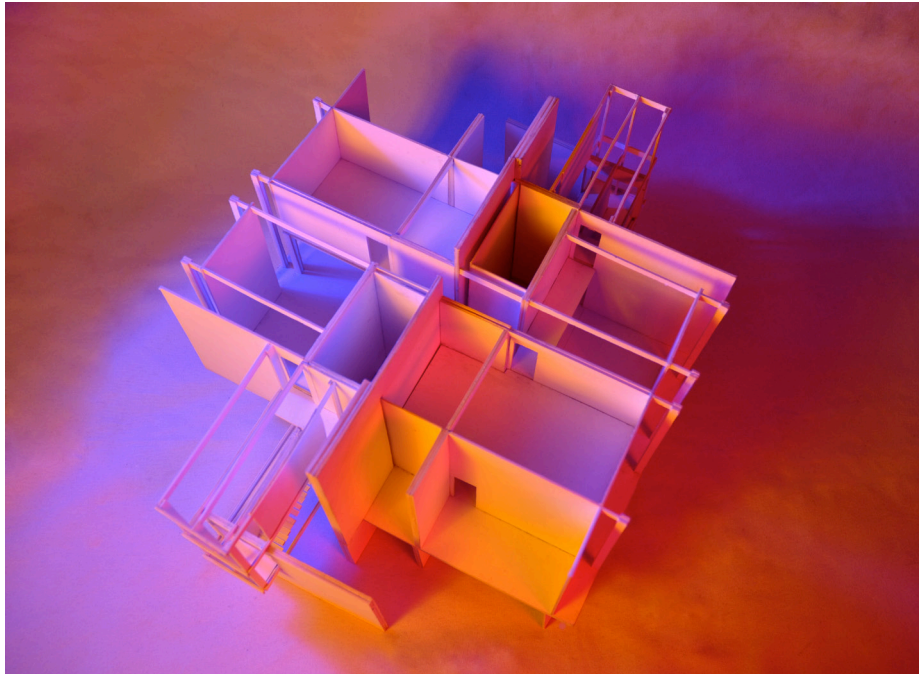

50

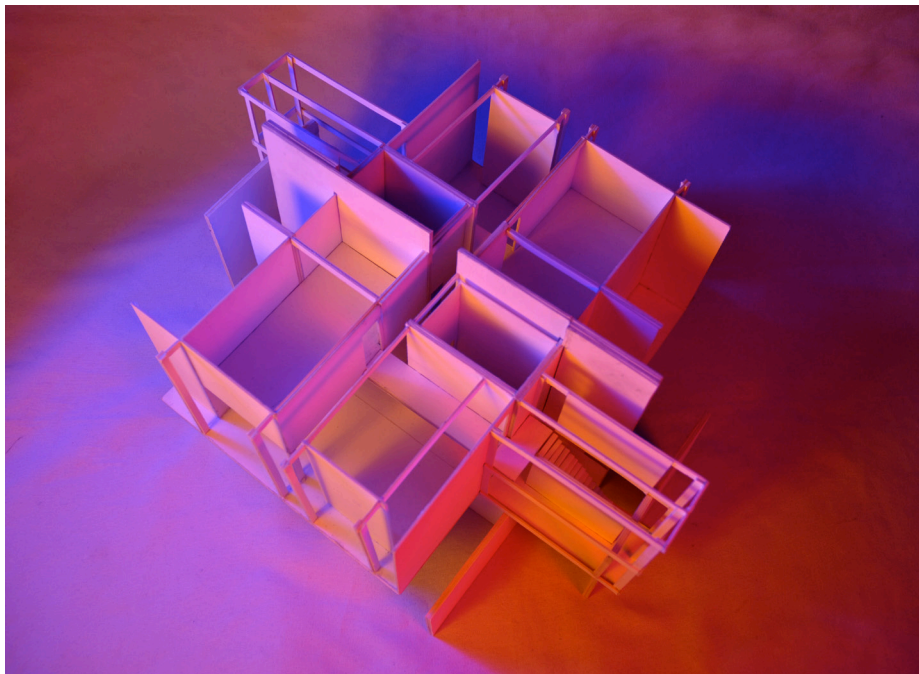





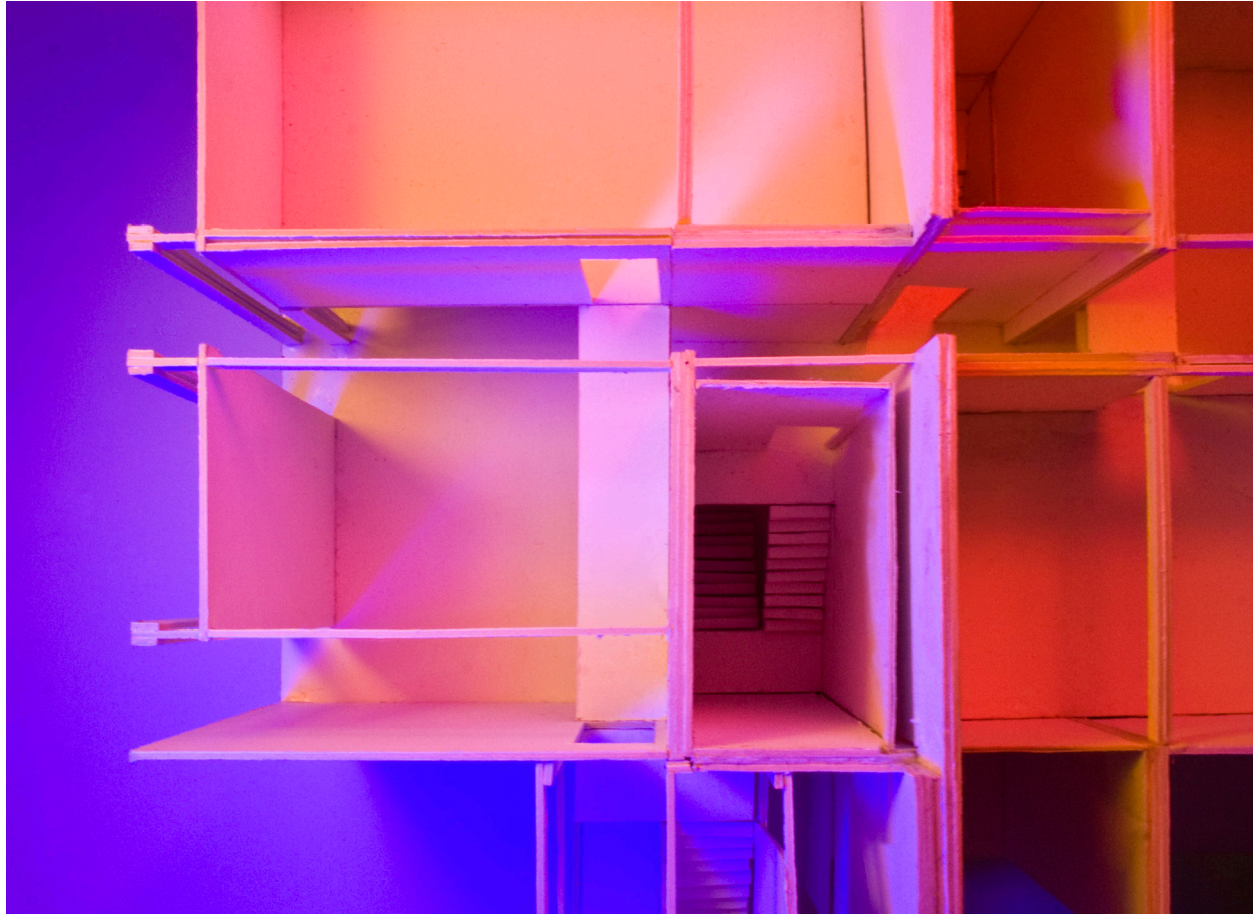

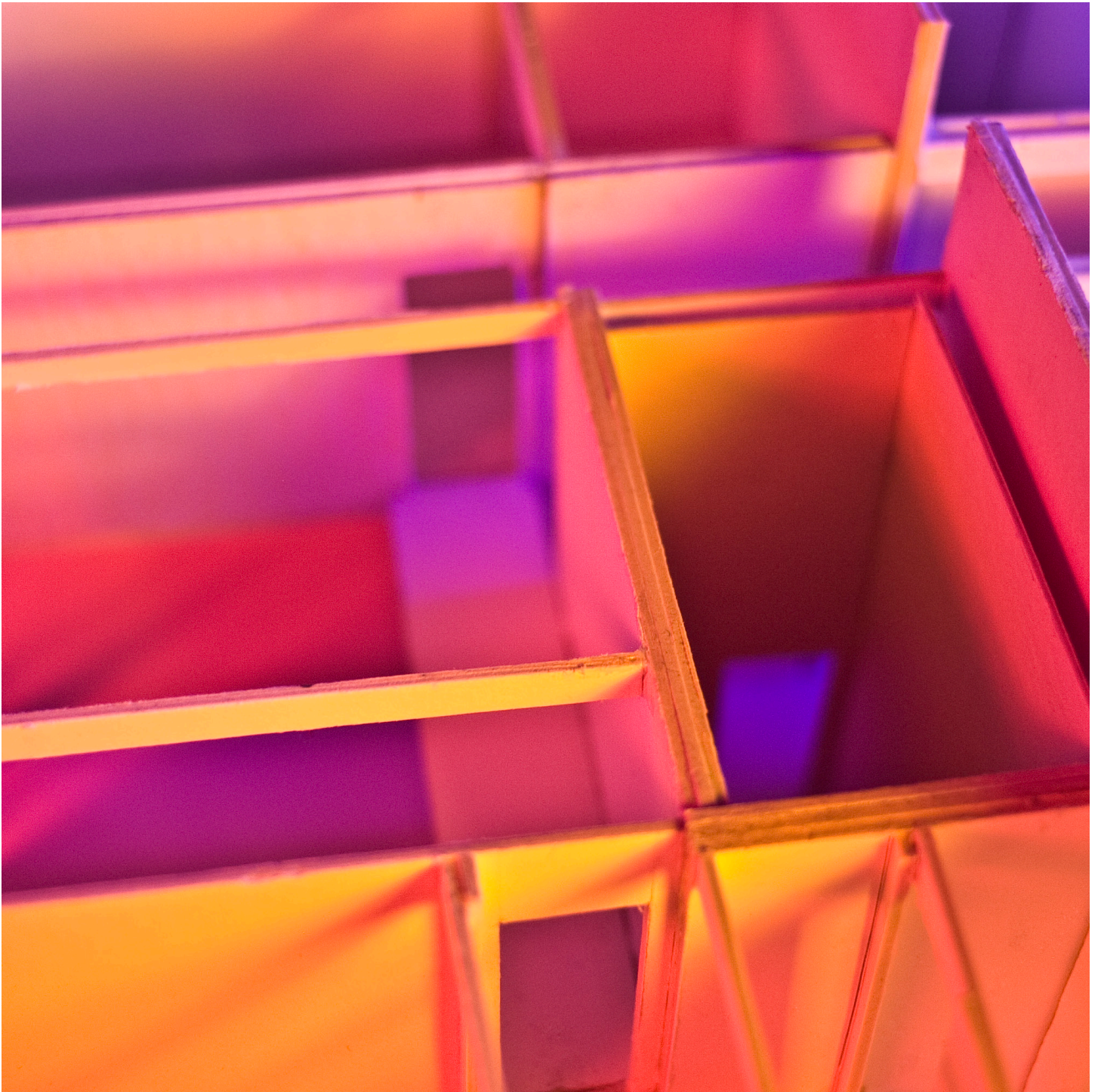





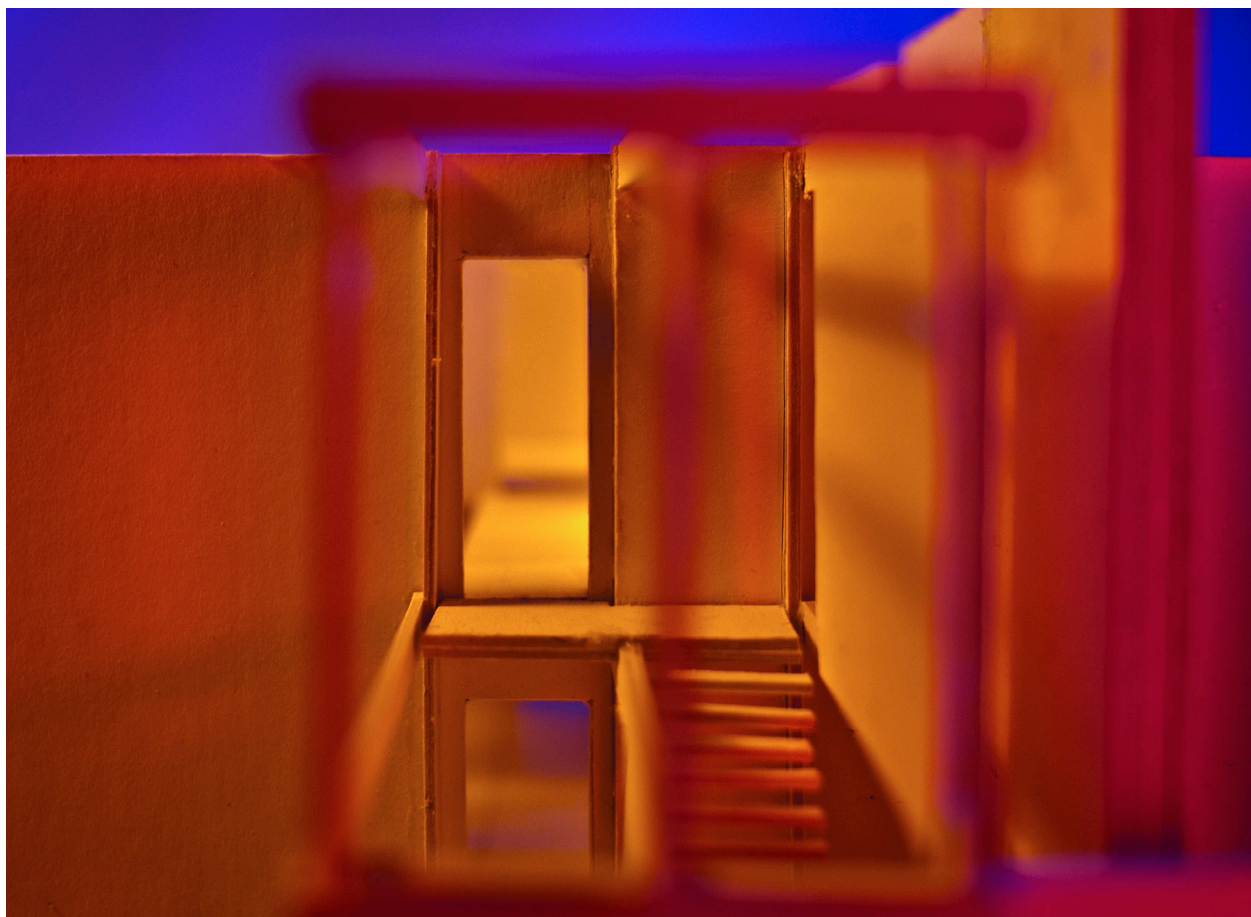

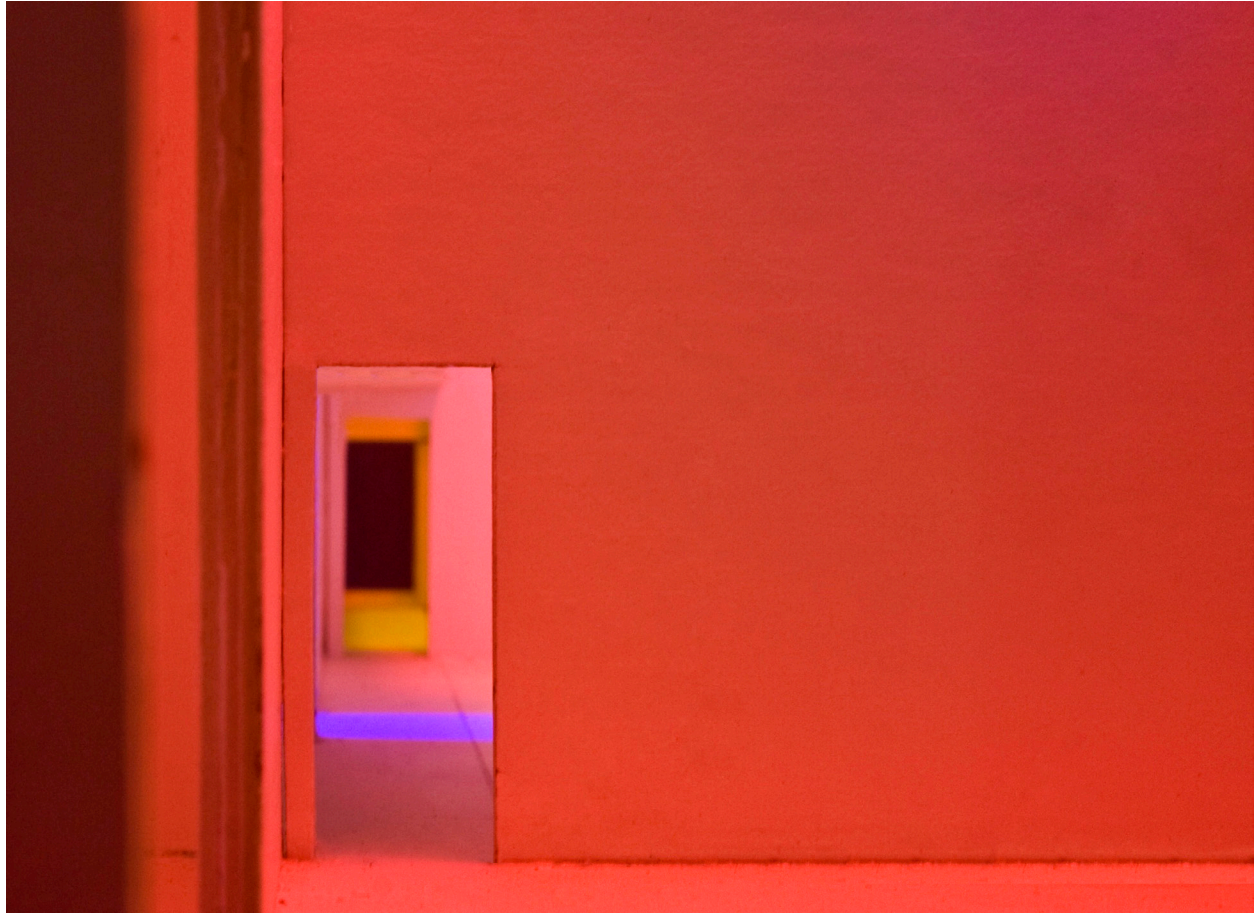







I start with an abstraction, and, because of the nature of the work, work toward the built world.

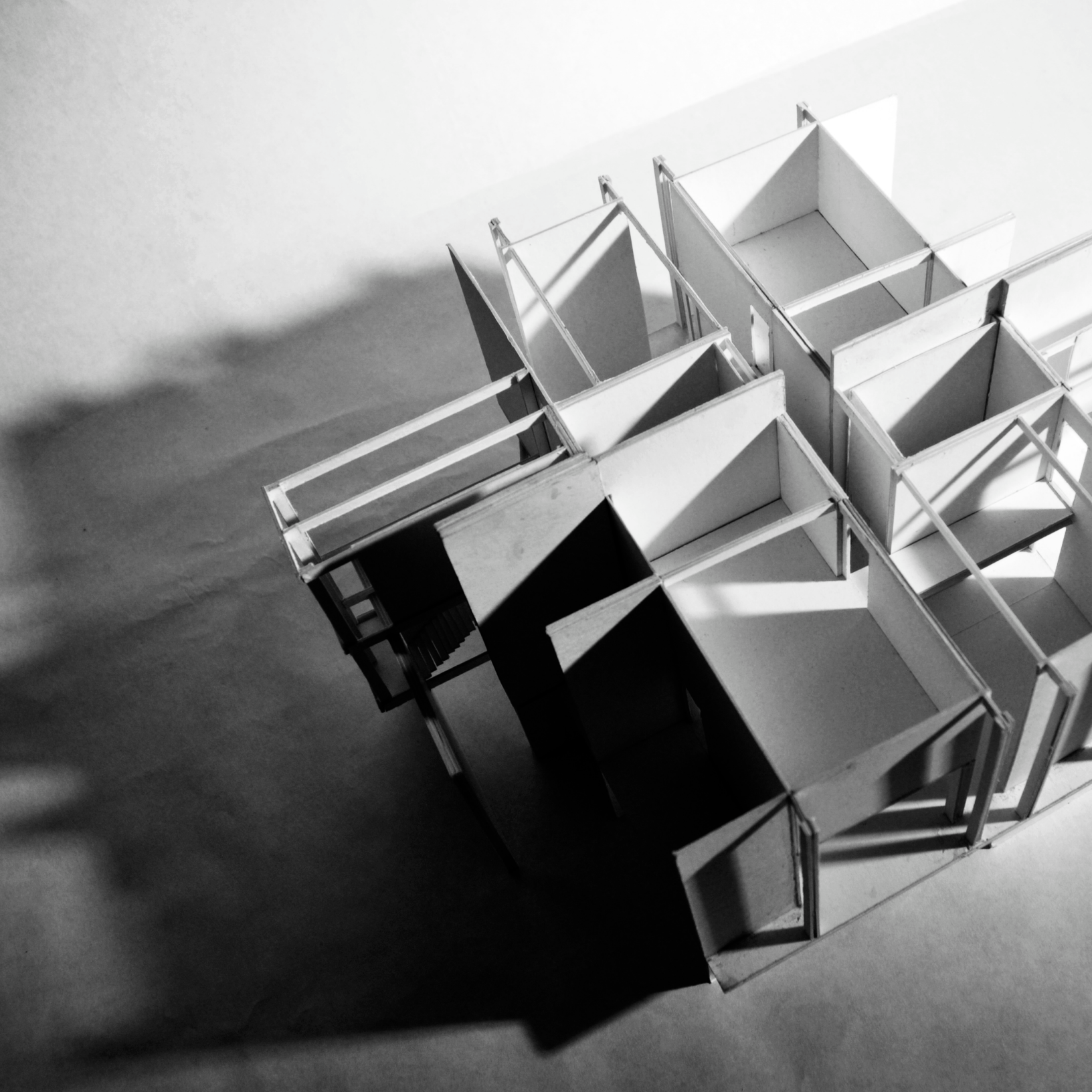

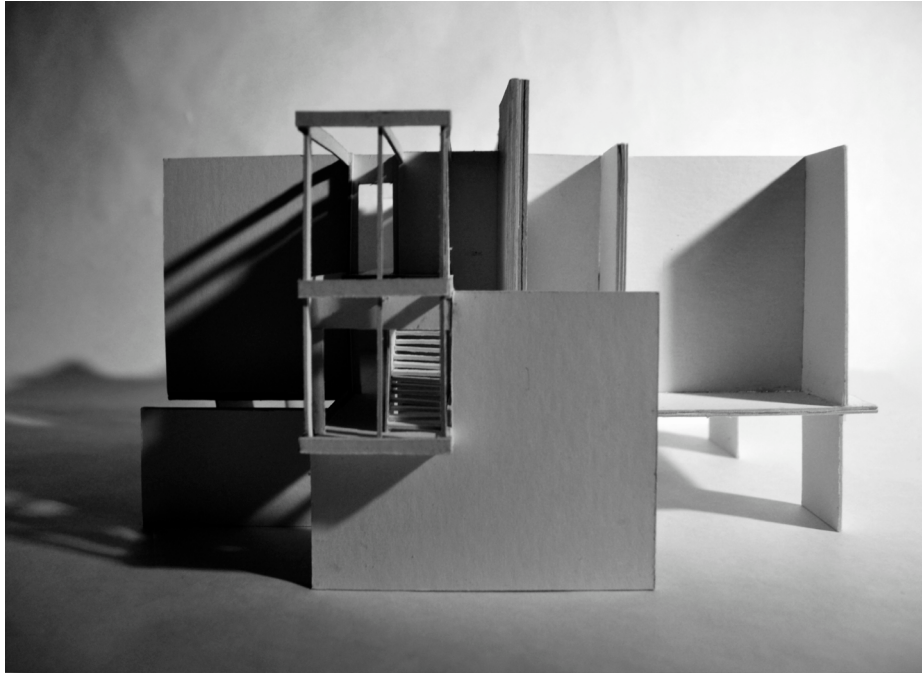

62

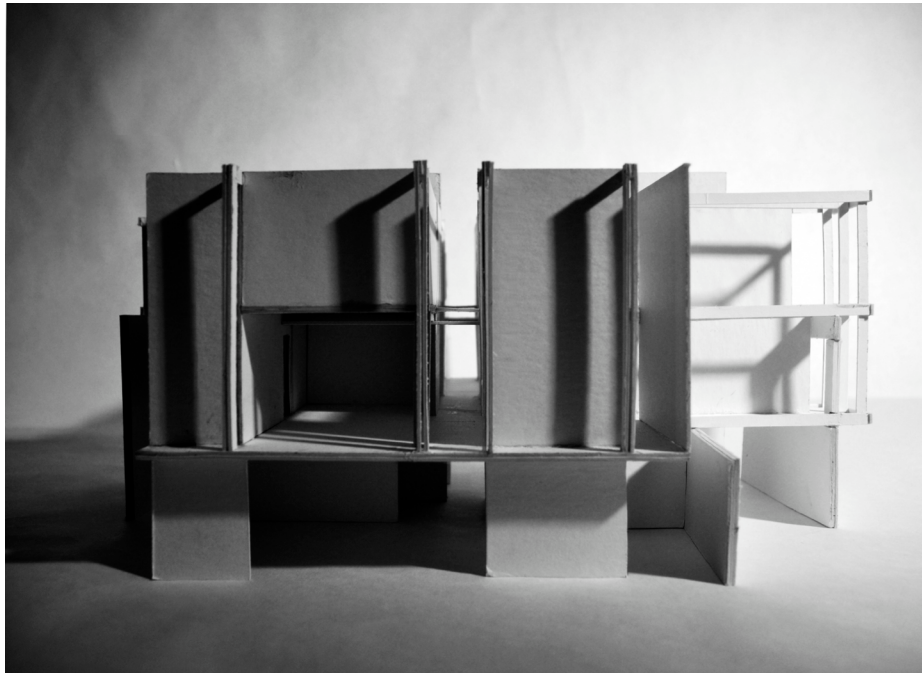

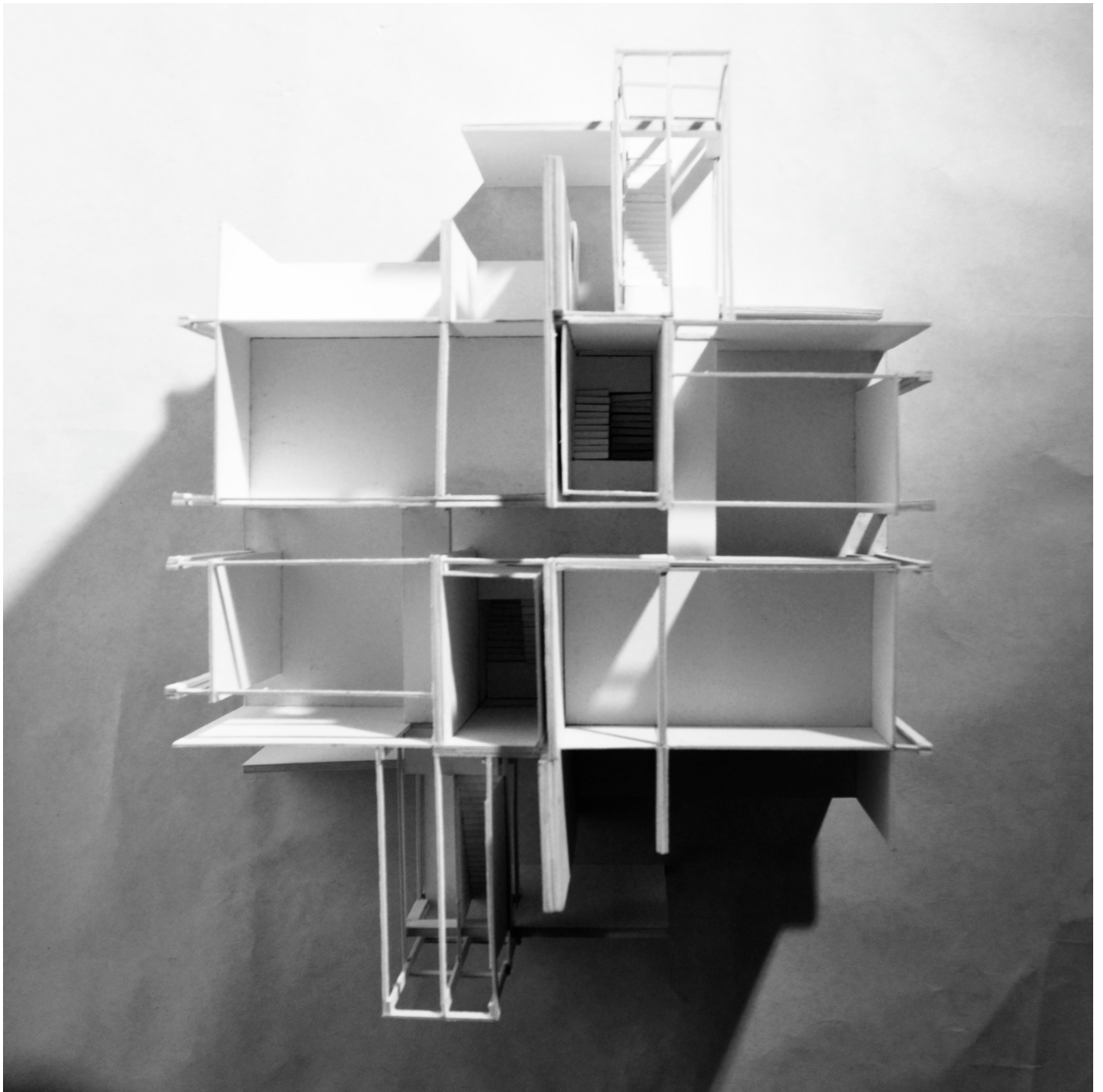

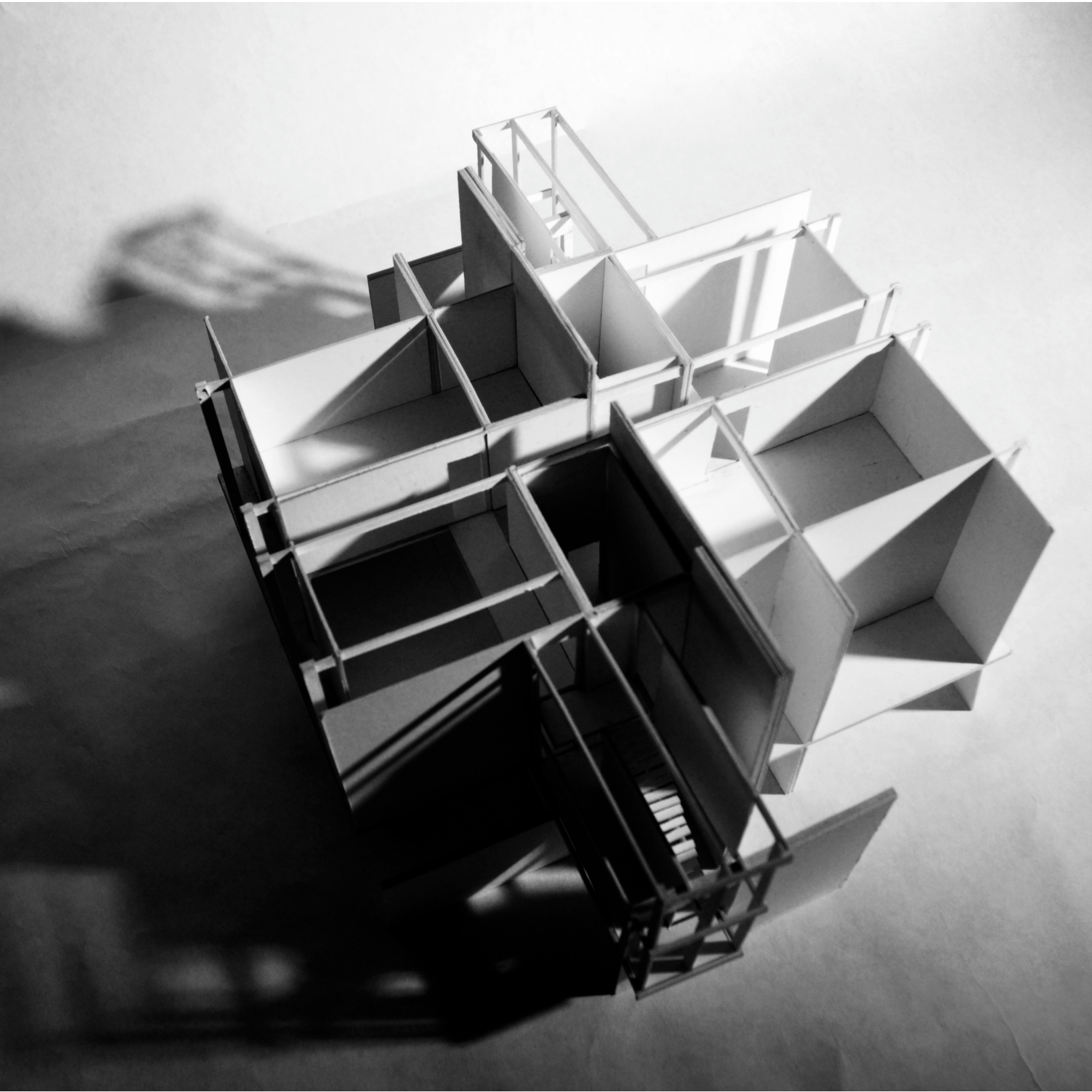

While I was putting together this book, I realized writing and making had become part of the discovering process.

This book became a tool of creation rather than explanation. It became a transition to House II.

This book extended what had happened to what may happen.