

Emergent Explorations: Analog and Digital Scripting

Alexander Gabriel Worden

Thesis submitted to the faculty of the Virginia Polytechnic Institute and State University in partial fulfillment of the requirements for the degree of

Master In Architecture

H. Scott Gartner - Committee Chair

William Galloway - Committee Member

William Green - Committee Member

April 29th, 2011
Blacksburg, Virginia

Keywords: Analog Computing, Textile, Crochet, Scripting

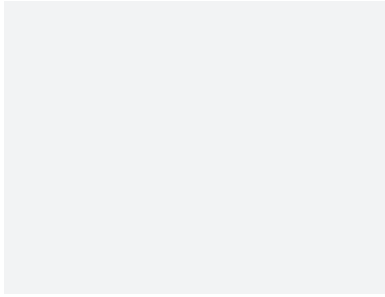

Emergent Explorations: Analog and Digital Scripting

Alexander Gabriel Worden

Abstract

This book documents an exploration of emergent and linear modes of defining space, form, and structure. The thesis highlights a dialog between analog and digital modeling techniques, in concept and project development. It identifies that analog modeling techniques, coupled with judgment, can be used to develop complex forms. The thesis project employs critical judgment and the textile techniques of crochet as a vehicle generate form.

Crochet lends itself to this investigation because it is a serial process of fabrication that allows for the introduction of specific non-linear modifications. The resulting emergent forms produced by this mode of working can be precisely described by digital modeling techniques. These analog crochet models are translated into the digital through the employment of advanced digital modeling tools. This translation enables the visualization, development, testing, and execution of an architectural space, form, and structure.

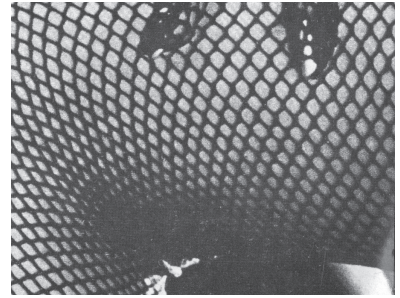
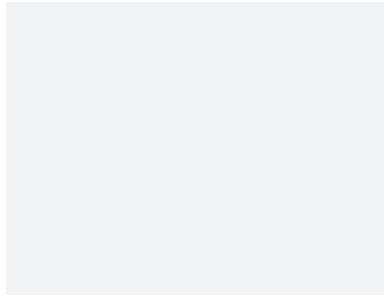

Acknowledgements

I dedicate this book to my parents, who have helped establish a strong base for me to build upon. To my muse, Audrey, who has always believed and supported every endeavor. I look forward to the many adventures we are to have together. Finally I hold great appreciation for my professors, supervisors and committee members who believed in my work and took a personal interest in these explorations.

I cannot thank you all enough for the continued support and encouragement. This book is a token of my appreciation.

Table of Contents

Abstract.....	iii
Acknowledgements.....	v
List of Figures.....	viii
Introduction.....	1
The Analog Model.....	3
The Spline.....	5
Analog Modeling Machines.....	7
Emergence (Self-Organization).....	9
Scripting (Rule-Based Making).....	11
The Knot and Techniques.....	13
Hyperbolic Crochet.....	15
Pattern Generators.....	17
Topology.....	21
Learning the Technique.....	23
Understanding Crochet.....	27

Explorations: Media.....	29
Explorations: Stiffening Agents.....	39
Explorations: Wrap and Stretch.....	57
Defining a Crochet Space.....	65
Generative Techniques in Crochet.....	69
Transformational Techniques in Crochet.....	75
Qualities of a Crochet Space.....	81
The Digital Crochet Structure.....	91
Translating Analog to Digital.....	99
Visualization, Fabrication and Testing.....	109
Crochet Architecture.....	149
Conclusion.....	151
Bibliography.....	153
Additional Readings.....	155
Image Credits.....	157

List of Figures

Fig. 1	Acrylic, Double Treble Crochet	Pg. 2
Fig. 2.1	Wool Thread Machine, Otto	Pg. 3
Fig. 2.2	Hanging Nets, IL 25	Pg. 4
Fig. 2.3	Guell Church, IL 34	Pg. 4
Fig. 2.4	Pneus In Nature, IL 9	Pg. 4
Fig. 3.1	Spline Weight, Lead Duck	Pg. 5
Fig. 3.2	Wood Spline	Pg. 5
Fig. 3.3	Wood Hull Drawings	Pg. 6
Fig. 3.4	Shipyards, 19th Century	Pg. 6
Fig. 4.1	Catenary Curve, IL 25	Pg. 7
Fig. 4.2	Gaudi Model, IL 34	Pg. 8
Fig. 4.3	Gaudi Model, IL 34	Pg. 8
Fig. 5.1	Wool Thread Machine, Otto	Pg. 9
Fig. 5.2	Experiments, IL 25	Pg. 10
Fig. 6.1	Knots, Semper	Pg. 11
Fig. 6.2	Nets In Nature and Technique, IL 8	Pg. 12
Fig. 6.3	Knots, Semper	Pg. 12
Fig. 7.1	Knots, Semper	Pg. 13
Fig. 7.2	Crochet Examples	Pg. 14
Fig. 8.1	Taimina, Hyperbolic Crochet	Pg. 15
Fig. 8.2	Topology Diagrams	Pg. 16
Fig. 8.3	Hyperbolic Crochet Model	Pg. 16
Fig. 9.1	Lorenz Manifold	Pg. 17
Fig. 9.2	Lorenz Manifold, Crochet Model	Pg. 18
Fig. 9.3	Crochet Pattern Generator	Pg. 19
Fig. 9.4	The Jacquard Loom	Pg. 20
Fig. 9.5	Crochet Pattern Generator	Pg. 20
Fig. 10.1	Crochet Thread	Pg. 21

Fig. 10.2	Circle and Ellipse	Pg. 21
Fig. 10.3	Torus - Coffee Cup/ Mobius - Klein Bottle	Pg. 22
Fig. 11.1	Crochet Chain	Pg. 23
Fig. 11.2	Yarn Over, Pull up Loop	Pg. 23
Fig. 11.3	Crochet Method 1	Pg. 24
Fig. 11.4	Crochet Method 2	Pg. 24
Fig. 11.5	Crochet Method 3	Pg. 24
Fig. 11.6	Slip Stitch	Pg. 25
Fig. 11.7	Slip Stitch Pattern	Pg. 25
Fig. 11.8	Single Crochet	Pg. 25
Fig. 11.9	Single Crochet Pattern	Pg. 25
Fig. 11.10	Half Double Crochet	Pg. 25
Fig. 11.11	Half Double Crochet Pattern	Pg. 25
Fig. 11.12	Double Crochet	Pg. 26
Fig. 11.13	Double Crochet Pattern	Pg. 26
Fig. 11.14	Treble Crochet	Pg. 26
Fig. 11.15	Treble Crochet Pattern	Pg. 26
Fig. 11.16	Double Treble Crochet	Pg. 26
Fig. 11.17	Double Treble Crochet Pattern	Pg. 26
Fig. 12.1	Hyperbolic Circle	Pg. 27
Fig. 12.2	Crochet Path, Triangle, Square, Circle, Cylinder	Pg. 27
Fig. 12.3	Crochet Figures - Square, Triangle, Circle	Pg. 28
Fig. 12.4	Crochet Figure - Cylinder	Pg. 28
Fig. 13.1.1	Manila Crochet	Pg. 29
Fig. 13.1.2	Kwangho Lee - Crochet Furniture	Pg. 30
Fig. 13.1.3	Kate Pokorny - Crochet Yurt	Pg. 30
Fig. 13.1.4	Yurt Sketch	Pg. 30
Fig. 13.1.5	Rockpool Candy	Pg. 30
Fig. 13.2.1	Acrylic Crochet Samples	Pg. 31
Fig. 13.2.2	Acrylic Crochet Sample	Pg. 31
Fig. 13.3.3	Sisal Crochet	Pg. 32
Fig. 13.3.4	Sisal Crochet	Pg. 32
Fig. 13.4.1	Rattan Crochet	Pg. 33
Fig. 13.4.2	Rattan Bending Experiment	Pg. 33
Fig. 13.4.3	Rattan Crochet	Pg. 34

Fig. 13.4.4	Rattan Bending Experiment	Pg. 34
Fig. 13.5.1	Manila Rope	Pg. 35
Fig. 13.5.2	Manila Crochet	Pg. 35
Fig. 13.6.1	Fishing Line Crochet	Pg. 36
Fig. 13.6.2	Fishing Line Crochet	Pg. 36
Fig. 13.6.3	Fishing Line Crochet Chain	Pg. 36
Fig. 13.7.1	Steel Cable Crochet Chain	Pg. 37
Fig. 13.7.2	Steel Cable Crochet Chain	Pg. 38
Fig. 14.1.1	Stiffening Experiments	Pg. 39
Fig. 14.1.2	Plaster Crochet	Pg. 40
Fig. 14.1.3	Lacquer Crochet	Pg. 40
Fig. 14.1.4	Lacquer Crochet Bending	Pg. 40
Fig. 14.1.5	Ceramic Crochet Experiment	Pg. 41
Fig. 14.1.6	Ceramic Crochet Experiment	Pg. 41
Fig. 14.1.7	Ceramic Crochet Experiment	Pg. 42
Fig. 14.2.1	Digital Crochet, 3D Print	Pg. 43
Fig. 14.2.2	Digital Spline, Animate Form	Pg. 44
Fig. 14.2.3	Digital Crochet Loop	Pg. 45
Fig. 14.2.4	Digital Crochet Chain, Rotated	Pg. 45
Fig. 14.2.5	Digital Crochet, Piped	Pg. 46
Fig. 14.2.6	Digital Crochet Chains	Pg. 46
Fig. 14.2.7	Grasshopper Script, Knit Surface, Piacentino	Pg. 47
Fig. 14.2.8	Grasshopper, Knit Module, Piacentino	Pg. 47
Fig. 14.2.9	Grasshopper, Knit Surface Render, Piacentino	Pg. 48
Fig. 14.2.10	Grasshopper, Knit Surface Module, Piacentino	Pg. 48
Fig. 14.2.11	Crochet Loop Module	Pg. 49
Fig. 14.2.12	Crochet Loop Module	Pg. 49
Fig. 14.2.13	Grasshopper Script, Crochet Surface	Pg. 49
Fig. 14.2.14	Crochet Surface Deformations	Pg. 50
Fig. 14.2.15	Rendering, Crochet Surface	Pg. 50
Fig. 14.2.16	Grasshopper Crochet Surface, Point Attractor	Pg. 51
Fig. 14.2.17	Digital Crochet Experiments	Pg. 51
Fig. 14.2.18	Digital Crochet Experiments	Pg. 52
Fig. 14.2.19	Digital Crochet Experiments	Pg. 52
Fig. 14.2.20	Digital Crochet Experiments	Pg. 53
Fig. 14.2.21	Digital Crochet Experiments	Pg. 54
Fig. 14.3.1	3D Print Crochet	Pg. 55

Fig. 14.3.2	3D Print Crochet	Pg. 56
Fig. 14.3.3	Sisal Crochet	Pg. 56
Fig. 15.1.1	Overstretching Experiment	Pg. 57
Fig. 15.1.2	Stretching Experiment	Pg. 58
Fig. 15.1.3	Crochet Clothing, Hand and Leg Warmers	Pg. 59
Fig. 15.1.4	Crochet Lingerie	Pg. 59
Fig. 15.1.5	Netting and Pneus, IL 9	Pg. 60
Fig. 15.1.6	Crochet and Pneus	Pg. 60
Fig. 15.2.1	Stretching Experiments	Pg. 61
Fig. 15.2.2	Stretching Experiments	Pg. 62
Fig. 15.3.1	Overstretching Experiments	Pg. 63
Fig. 15.3.2	Overstretching Experiments	Pg. 64
Fig. 16.1.1	Crochet Surface	Pg. 65
Fig. 16.1.2	Endless house, Kiesler	Pg. 66
Fig. 16.1.3	Analog Paper Models, Spuybroek	Pg. 67
Fig. 16.1.4	Analog Paper Models, Spuybroek	Pg. 67
Fig. 16.1.5	Stretching Experiment	Pg. 68
Fig. 16.1.6	Analog Crochet Models	Pg. 68
Fig. 17.1.1	Hyperbolic Crochet Triangle Model	Pg. 69
Fig. 17.1.2	Hyperbolic Crochet Model	Pg. 70
Fig. 17.2.1	Branching, Crochet Chain	Pg. 71
Fig. 17.2.2	Branching, Crochet Model	Pg. 71
Fig. 17.2.3	Branching, IL 8	Pg. 71
Fig. 17.3.1	Stuttering, Crochet Model	Pg. 72
Fig. 17.4.1	Omitting, Crochet Model	Pg. 73
Fig. 17.4.2	Omitting, Crochet Model	Pg. 73
Fig. 17.4.3	Crochet Stitch Examples	Pg. 74
Fig. 18.1.1	Crochet Hat	Pg. 75
Fig. 18.2.1	Stitch Examples	Pg. 76
Fig. 18.2.2	Stitch Examples	Pg. 76
Fig. 18.3.1	Pleating Examples	Pg. 77
Fig. 18.4.1	Stretching Examples	Pg. 78
Fig. 18.4.2	Analog Crochet Space	Pg. 79
Fig. 18.4.3	Crochet Pattern	Pg. 80

Fig. 18.4.4	Analog Crochet Space	Pg. 80
Fig. 19.1.1	Endless House, Kiesler	Pg. 81
Fig. 19.1.2	Endless House Drawings, Kiesler	Pg. 82
Fig. 19.2.1	Analog Crochet Model, Private Space	Pg. 83
Fig. 19.2.2	Analog Crochet Model, Private Space	Pg. 84
Fig. 19.3.1	Analog Crochet Model, Public Space	Pg. 85
Fig. 19.3.2	Analog Crochet Model, Public Space	Pg. 86
Fig. 19.4.1	Analog Crochet Model, Convergent Space	Pg. 87
Fig. 19.4.2	Analog Crochet Model, Convergent Space	Pg. 88
Fig. 19.4.3	Analog Crochet Model	Pg. 89
Fig. 19.4.4	Digital Crochet Model	Pg. 90
Fig. 20.1.1	Overstretching Experiment	Pg. 91
Fig. 20.1.2	Digital Helix with Bracing	Pg. 91
Fig. 20.1.3	Stretched Digital Helix with Bracing	Pg. 92
Fig. 20.2.1	Parametric Helix, Nettelblatt	Pg. 93
Fig. 20.2.2	Parametric Helix, Nettelblatt	Pg. 93
Fig. 20.2.3	Grasshopper Script, Parametric Helix, Nettelblatt	Pg. 94
Fig. 20.2.4	Parametric Helix	Pg. 94
Fig. 20.3.1	Nets in Nature and Technique, IL 8	Pg. 95
Fig. 20.3.2	Grasshopper Script, Parametric Bracing	Pg. 95
Fig. 20.3.3	Parametric Helix with Bracing	Pg. 96
Fig. 20.3.4	Rendering, Parametric Structure	Pg. 96
Fig. 20.4.1	Mapping The Helix and Bracing	Pg. 97
Fig. 20.4.2	Grasshopper Script, Mapping Helix and Bracing	Pg. 97
Fig. 20.4.3	Renderings, Mapped Helix and Bracing	Pg. 98
Fig. 21.1.1	3D Scanned Crochet Model	Pg. 99
Fig. 21.1.2	Digitized Analog Crochet Model	Pg. 100
Fig. 21.1.3	Digitized Analog Crochet Model	Pg. 101
Fig. 21.1.4	Rendering, Digital Crochet Model	Pg. 102
Fig. 21.1.5	Rendering, Digital Private Space	Pg. 104
Fig. 21.1.6	Rendering, Digital Public Space	Pg. 106
Fig. 21.1.7	Rendering, Digital Convergent Space	Pg. 108
Fig. 22.1.1	Visualization, 3D Print of Digital Crochet Model	Pg. 109
Fig. 22.1.2	Visualization, Rendering, Digital Model	Pg. 110

Fig. 22.2.1	Visualization, Rendering, Digital Model	Pg. 111
Fig. 22.2.2	Visualization, Rendering, Digital Model	Pg. 112
Fig. 22.2.3	Visualization, Rendering, Digital Model	Pg. 114
Fig. 22.3.1	Fabrication, 3D Print	Pg. 115
Fig. 22.3.2	Fabrication, 3D Print	Pg. 116
Fig. 22.3.3	Enrico Dini, Large Scale 3D Print	Pg. 117
Fig. 22.3.4	Fabrication, 3D Print	Pg. 118
Fig. 22.3.5	Fabrication, 3D Print	Pg. 120
Fig. 22.3.6	Fabrication, Laser Cut, Exploded Helix	Pg. 121
Fig. 22.3.7	Fabrication, Laser Cut, Unrolled Helix	Pg. 121
Fig. 22.3.8	Fabrication, Rendering of Model	Pg. 122
Fig. 22.3.9	Fabrication, Laser Cut, Image of Model	Pg. 124
Fig. 22.4.1	Testing, Lamination	Pg. 125
Fig. 22.4.2	Testing, Rendering of Model	Pg. 126
Fig. 22.4.3	Testing, Rendering of Model	Pg. 128
Fig. 22.4.4	Testing, Exploded Helix Lamination Model	Pg. 129
Fig. 22.4.5	Testing, Wood Lamination Model	Pg. 130
Fig. 22.4.6	Testing, Images of Lamination Model	Pg. 132
Fig. 22.4.7	Testing, Images of Lamination Model	Pg. 134
Fig. 22.4.8	Testing, Images of Lamination Model	Pg. 136
Fig. 22.4.9	Testing, Bracing Connection	Pg. 137
Fig. 22.4.10	Son-O-House, Ruled Surface, Spuybroek	Pg. 138
Fig. 22.4.11	Son-O-House, Image, Spuybroek	Pg. 138
Fig. 22.4.12	Son-O-House, Rules for Surface, Spuybroek	Pg. 138
Fig. 22.4.13	Testing, Foam Model of Connection	Pg. 139
Fig. 22.4.14	Testing, Prototype Connector	Pg. 140
Fig. 22.4.15	Testing, Ball Joint Connector	Pg. 141
Fig. 22.4.16	Testing, Ball Joint Connector	Pg. 142
Fig. 22.4.17	Range of Motion Diagram	Pg. 142
Fig. 22.4.18	Pneumatic Bracing Member	Pg. 143
Fig. 22.4.19	Rendering of The Structure	Pg. 144
Fig. 22.4.20	Rendering of The Structure	Pg. 146
Fig. 22.4.21	Rendering of The Structure	Pg. 148
Fig. 23	Manila Rope Crochet	Pg. 150
Fig. 24	Analog Crochet Model, Private Space	Pg. 152

“One should have to show that all technical, mechanical and economic means that we have invented and that give us an advantage over the past will lead to barbarity rather than indicate the progress of true industrial art or civilization, as long as we are generally unsuccessful in mastering these means artistically.”

- Gottfried Semper, The Four Elements of Architecture

Introduction

Over one hundred and thirty years ago, Gottfried Semper stated that the innovation and implementation of new technologies would enable us to rise above our past. It is imperative that these means and techniques be used to their fullest extent. Failure to understand and master new technologies, while applying critical judgment to the result, will only lead to the rapid regression of ourselves and our culture. The continual advent of digital modeling software has translated analog techniques into the virtual domain. This virtualization is slowly removing the requirement of physical modeling and abstracting the human hand in the process. Through the employment of parametrics in design, those who do not fully understand the tool begin to believe that the computer is the generator of form. This can lead to the dangerous misconception that the digital result no longer needs to be judged by the designer. These misunderstandings can be avoided through the study of analog models and techniques.

This book examines historical precedents in complex modeling that vary from traditional ship building techniques, the experiments of Antonio Gaudi and Frei Otto, and opportunities found in textiles. These models and techniques look at the relationship of physical modeling, material properties, and the emergence of form, which is then judged by the designer. This research identifies that specific methods of textiles exemplify the dichotomy between emergent and linear modes

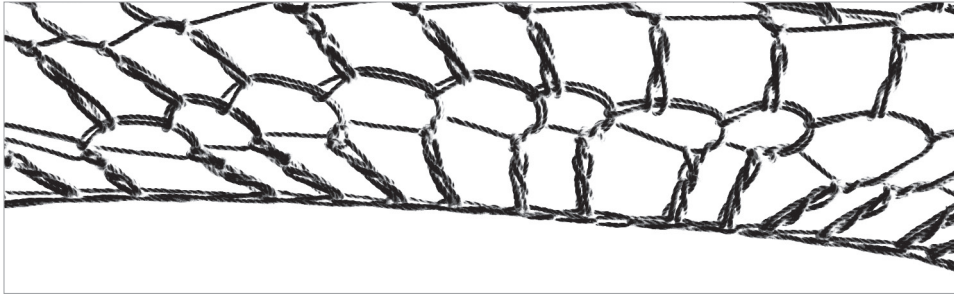

Fig. 1

of working. The textile technique of crochet enables the strict linear development of a product through pattern and the ability to work freely towards a undefined goal. Additionally, crochet has been use to physically model and prove complex mathematical theory and systems. It is because of this, that crochet is selected as the vehicle for an emergent exploration of space, form, and structure.

In order to use crochet to define and generate an architectural space, the technique must be mastered. This book looks at the basic technique of crochet and begins exploration through the construction of geometric figures, changes in media, stiffening agents, and translation into a digital crochet. These explorations use the technique to allow for the development of qualitative models. These results can lead to the continual development or prompt a different path of exploration. The explorations rely on the existence of opportunity and critical judgment of the result. Each decision can then lead to unforeseen and emergent outcomes. These emergent explorations enable the redefinition of the analog crochet model into an architectural system that is reconstructed digitally, through the use of contemporary modeling tools. This textile technique informs not only space and structure, but the way of working within the digital environment. The digital becomes an aid in the development, visualization, fabrication, and execution of the concept.

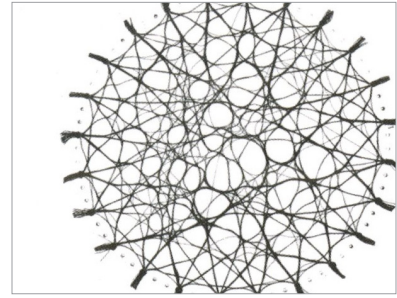
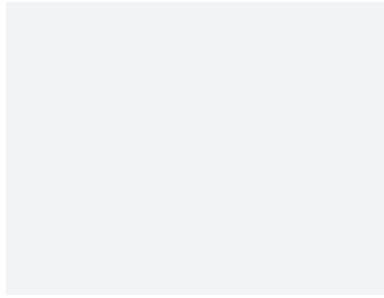
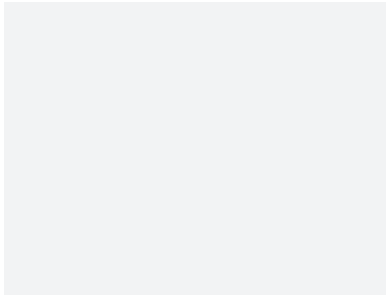

Fig. 2.1

The Analog Model

The physical analog model plays a critical role in the realization of ideas, concepts, and theories. Over centuries, techniques in modeling have been discovered, developed, and refined. Though the result is directly influenced by both material and method of its creation, the techniques are not exclusive to the result. Method, process, and technique are freely interchangeable within the realm of making. The analog model is an iterative process that requires the constant testing, checking, and refinement, in order to achieve the desired design. The analog model enables the direct communication between process, material, natural law, and design intent. This interactive dialog can give rise to unexpected and unforeseen results.

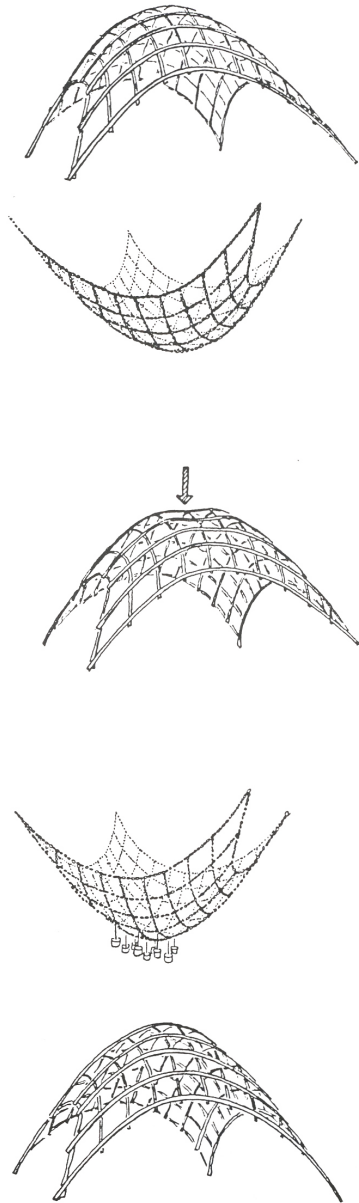

Fig. 2.2

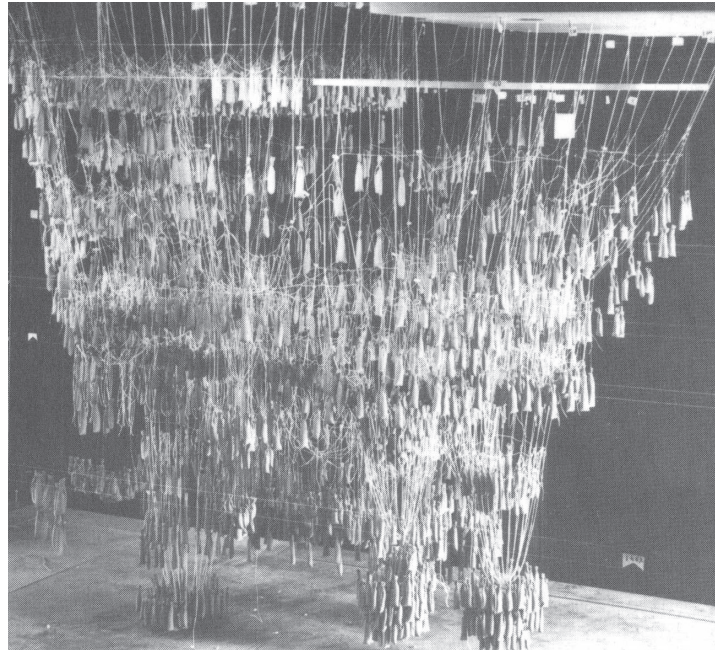

Fig. 2.3

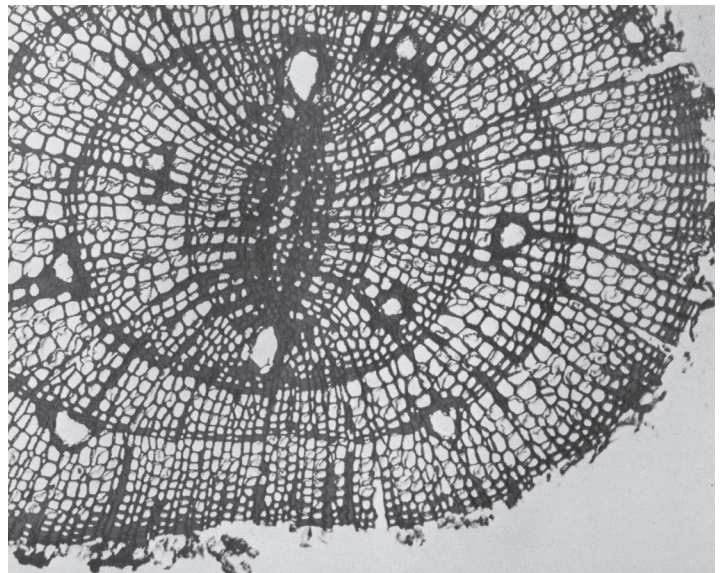

Fig. 2.4

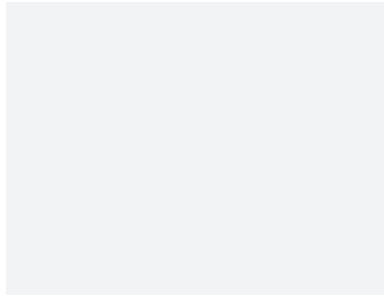
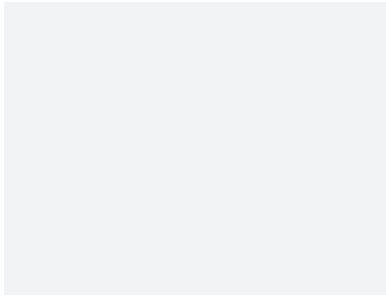

Fig. 3.1

The Spline



Fig. 3.2

In 17th century ship building, the curvature of boats hulls were drawn and constructed by the bending of individual wooden slats. These slats were bent into shape by the use of large lead weights called ducks. Through the use of the weights, each wooden slat could be jigged into the desired curvature. This allowed the boat builders to tailor each slat that was then used to build, or loft, the surface of the hull. These curved wooden slats came to be known as splines.

In the jigged system, the curvature of the wooden spline is directly influenced by each individual weight. This relationship between each weight is due to the natural bending ability of the wood. Within the jig, the entire system and curvature of the spline is changed with the adjustment of one weight. These points along the wood spline, where the ducks are connected, came to be known as control points or control vertices.

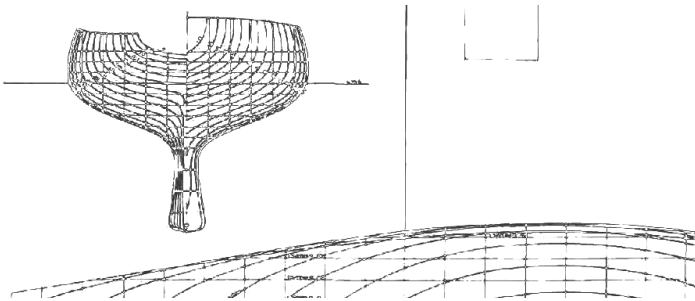
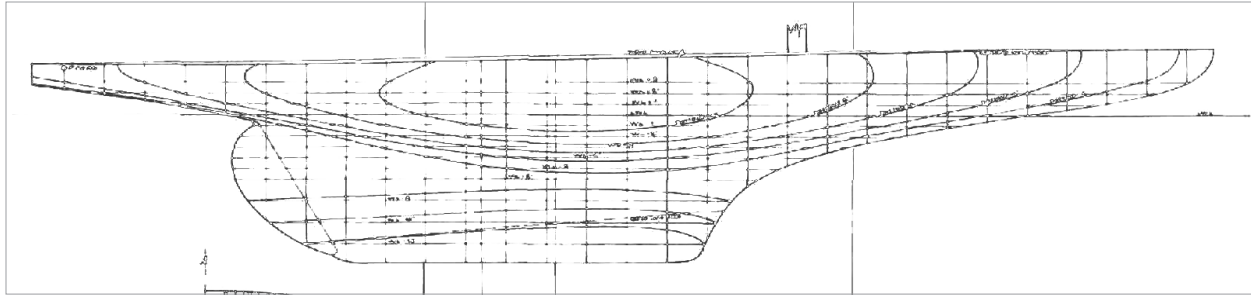

Fig. 3.3

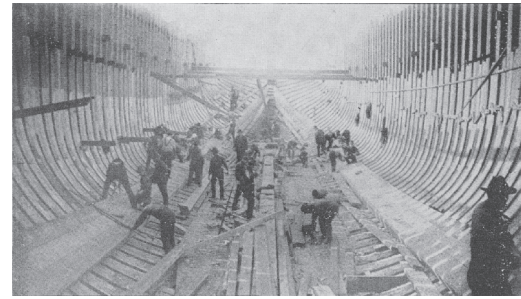

Fig. 3.4

“A spline can accommodate weights and gravities directed in free space. The points or “control vertices”, from which these weights hang, and through which the spline flows, are located in X,Y,Z coordinates space.”
(Lynn,22, Animate Space)

A spline is not exclusive to boat building or to any one material. The spline can be derived from other materials, everything from thread, string, rope, and hair. In these cases, the control vertices are no longer large lead weights, but are forces applied to the material. The use of the spline is crucial in the explorations and experimental models of Gaudi and Otto. They begin to employ the use of gravity and additional weights into their models, as well as the addition of liquid agents, such as water, whose properties change the structure and configuration of the entire system.

Analog Modeling Machines

“It is no small modification from engineering to design, from using the tool afterwards in order to establish structural validity to using the tool during the design process itself.” (Spuybroek, 130, The Architecture of Continuity)



Fig. 4.1

The architect Antonio Gaudi embraced the natural laws and material states to design the Guell church in Santa Coloma De Cervello. By using linen thread, weights and gravity, Gaudi, with the aid of highly qualified workers, constructed a hanging model of the church. By inverting the plan and securing it to the ceiling, Gaudi connected the threads to the points on the plan and one another. This created a system of hanging threads. This method of modeling is based on the principle of an inverted catenary line. In a suspended thread, carrying only its own weight, the resulting curvature of the thread is a catenary curve. This curve exists purely in tension, because the opposite of tension is compression, when inverted, the catenary curve can achieve equilibrium in compression. Gaudi understood this and by using this method, he could achieve complex structures in, which their loads were calculated by the material and gravitational properties.

“The hanging model is determined basically by a self forming process. Unlike ordinary models where the architect chooses a form, the hanging model independently forms a stable figure in equilibrium from the amounts of weight established by the architect. (IL 34, 20, The model)

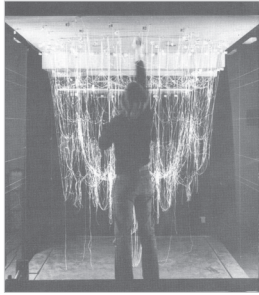

Fig. 4.2

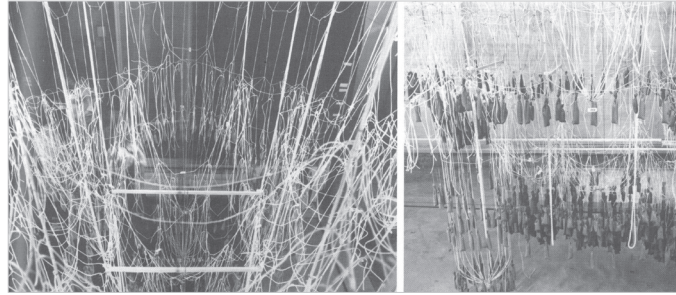

Fig. 4.3

Gaudi was able to actively affect the entire system by attaching weighted sacks to various points along the threads. These weights began to change the configuration of the model and because each thread was connected to another, when one weight is added, the entire system adjusted. During the creation of the model, judgment is actively involved in its creation. It is the architect who defines the relationships allowing the material to respond and adjust towards equilibrium within the analog machine.

Frei Otto and his team from the Institute for Lightweight Structures dedicated an entire IL publication (IL 34: The model) to the reconstruction of Gaudi's model. Using what little documentation still existed of Gaudi's original, the IL team was successful in reconstructing the model. Though rebuilding Gaudi's model occurred in 1982, Otto and his team were exploring natural systems and modeling techniques decades prior to the model. Frei Otto and his team, at the Institute for Lightweight Structures, continued to explore a vast array of different analog machines and natural systems beyond that of the hanging model. Through experiment in techniques and the use of other materials, they continued their search to find form.

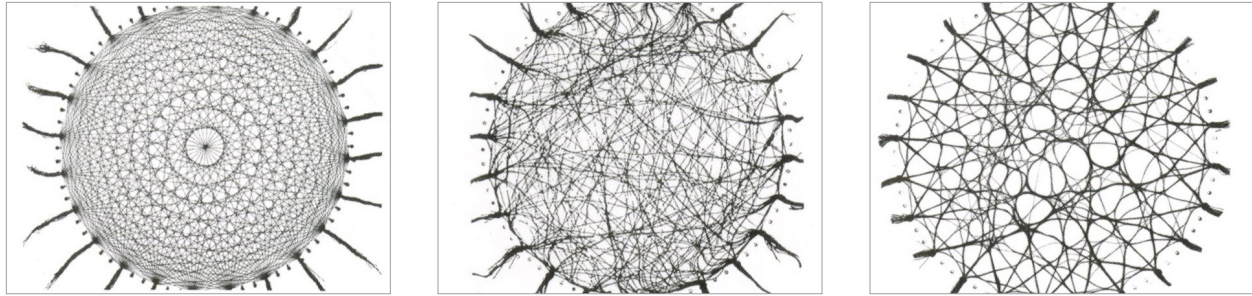

Fig. 5.1

Emergence (Self-Organization)

*“Emergence is the spontaneous occurrence of an organization or a behavior that is greater than the sum of its parts. - emergence is a change in kind, it is unknown and resembles nothing that we can already see.”
(Rahim, 03-80, Catalytic Formations)*

Frei Otto’s research spanned multiple decades, allowing for experiment after experiment, studying, and observing systems found in nature and human techniques. His research in soap bubbles and soap film is, to this day, the basis for progressive works of architecture. By working with the medium of water and soap, it offered Otto and his team a chance to experiment with constantly variable and unique structures. The aggravation of the mixture results in pockets of air surrounded by a soap film membrane. These formations are known as minimal surfaces. The structure of the minimal surface is based on its material properties and its boundaries. In water, the bubbles float and attract towards one another, creating clusters. When a figure or independent boundary enters the solution the resultant structure of the soap film changes. If a ring is immersed into the soap film and then removed, the film creates a membrane within the ring. (Fig. 5.2) Similarly, when a closed system of threads is immersed and removed, the film creates a membrane. Due to the properties of water and soap, the membrane begins to pull the threads together, resulting in an optimized or minimal surface. Though there are mathematical formulas for such structures, the analog model enables the constant testing of a surface without numerical calculation.

Otto and his team produced another study in self organization. To develop an emergent system that could produce a minimal path between houses in a development, they enlisted the use of wool threads and water. Otto and his team used a ring of threads to develop what they called optimized path systems. In doing so, they had designed a static geometric grid (Fig. 5.1). In order to achieve an optimized path, each thread was lengthened by 8 percent, and then immersed in water. Once the system had been removed, the threads became saturated with water, reconfiguring themselves into an efficient optimized wet grid. The result of the over-lengthening and addition of an agent - water - allow for the deviation of the material to restructure itself based on its inherent properties.

This bottom-up approach allows for stability, continuity, and variation in a system or a design. It is the emergence of a higher law, a law of material and physics that gives rise to unforeseen outcomes that can then be evaluated by the designer. Within Otto's thread machine and minimal surfaces, boundaries must be defined, which allow for deviation and an addition of an agent. However, there are analog techniques that incorporate both emergent (bottom-up) and a predetermined (top-down) approach. These techniques can be found in the technique of textiles fabrication.

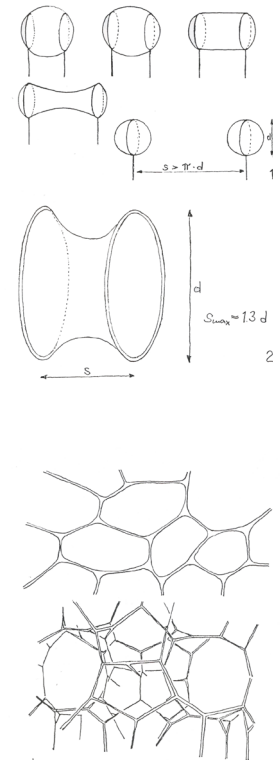

Fig. 5.2

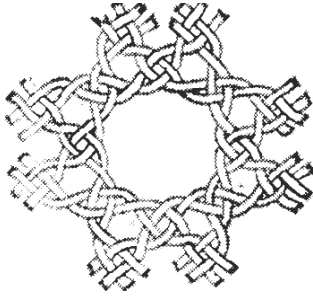

Fig. 6.1

Scripting (Rule-based Making)

*“The beginning of building coincides with the beginning of textiles.”
(Semper, 60/254, Four Elements)*

In *The Four Elements of Architecture*, Gottfried Semper proposed that textiles, or hanging rugs, were the first dividers of space. In its earliest stages, the wall was constructed from branches and plant fibers, woven together into a surface and pulled over inner supports. Though many cultures covered the woven surface with clay or mud, the textile was still the very essence of the wall.

These techniques enabled the articulation of space through the very surface used to contain it. The overlapping of materials gave rise to beautifully ornate surfaces, in which a culture recorded its history and traditions. The textile wall became the record keeper. Patterns and images were woven into the mats and surfaces, telling important stories of their history.

These surfaces were crafted by weavers, wicker, and textile workers. This was possible through the development of setting up rules and patterns in order to execute the desired outcome. These rules or formulas were written, drawn, or simply created without a pattern, working solely from the mind's eye. These techniques employ rules set by the fabricator so that each step in constructing the surface, accurately articulates the end product. This requires constant dialog between the bottom-up

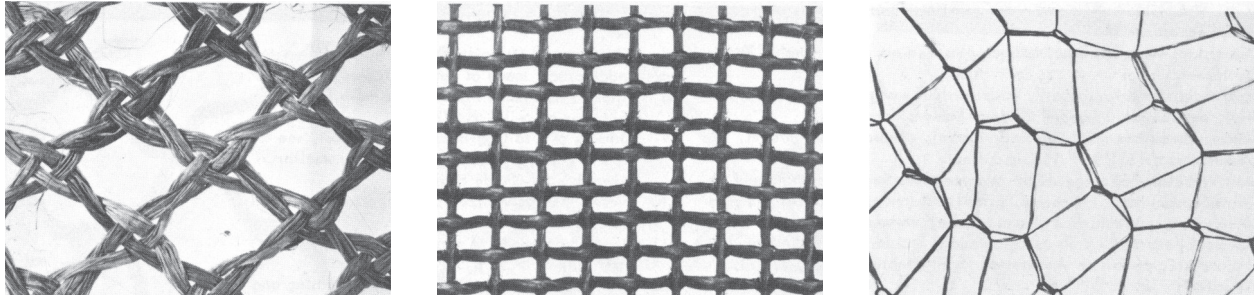

Fig. 6.2

technique and top-down design. In an excerpt of *The Textile Art*, found in the *Four Elements of Architecture*, Semper calls for a greater exploration the textile techniques, an area of making that he calls “a rich subject matter” and explores the many different methods of making in textiles.

“All operations in the textile arts seek to transform raw materials with the appropriate properties into products, whose common features are great pliancy and considerable absolute strength, sometimes used as pliant surface to cover, to hold, to dress, to enclose, and so forth.” (Semper, 215, Four Elements)

All textiles begin with threads, cords or bands that must first be fabricated. These threads are made by the twisting of the fibers to increase strength and elasticity. Spun yarn and twisted yarn are both an artificial thread and a method of making long threads from many different fibers.

Braiding, pleating, and weaving are alternatives in making cords, rope, and surfaces by using materials where the configuration of many is organized and assembled based on techniques. These techniques are a prime example of a rule-based making or scripting. In addition to these techniques Semper acknowledges a particular technique in textile art that promotes the greatest degree of exploration, the knot.



Fig. 6.3

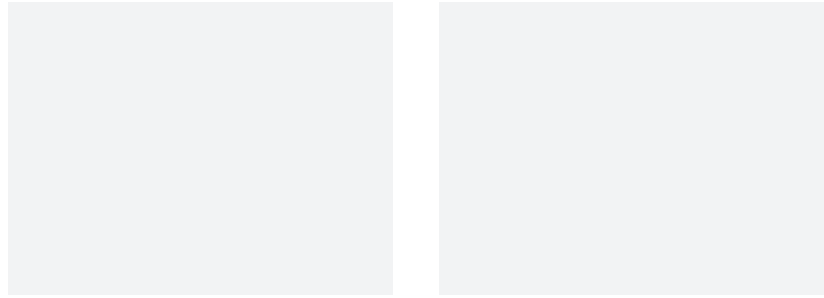

The Knot and Techniques

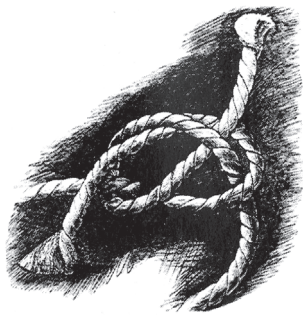

Fig. 7.1

A knot is a means of joining. Its strength is based on both friction and by the method in which the cable was constructed. When pulled, the lateral friction exerts pressure on itself, making the knot stronger when in tension. Over the centuries, sailors and rope makers have invented thousands of different knots tailored for specific purposes. The combination of ropes secured to one another by knots give rise to simple nets, a primary tool man has used for centuries. Nets made from simple weaver knots were commonly used to hunt and fish. Advantages of mesh nets are that if portion of the net is damaged, the flaw does not affect the whole system and is easily repaired. However, knotting techniques of garment making is quite the opposite.

More commonly known as the slipknot, the loop stitch is a knot whose loosening can lead to the unraveling of the entire system. Mostly for use in garments, the loop stitch is employed in the textile techniques of knitting and crochet. The technique can be used to create many different articles of clothing from sweaters to delicate lace.

Both knitting and crochet are simple loop techniques that give rise to great detail, variation, articulation, and ornament. Textile techniques employ a wonderful

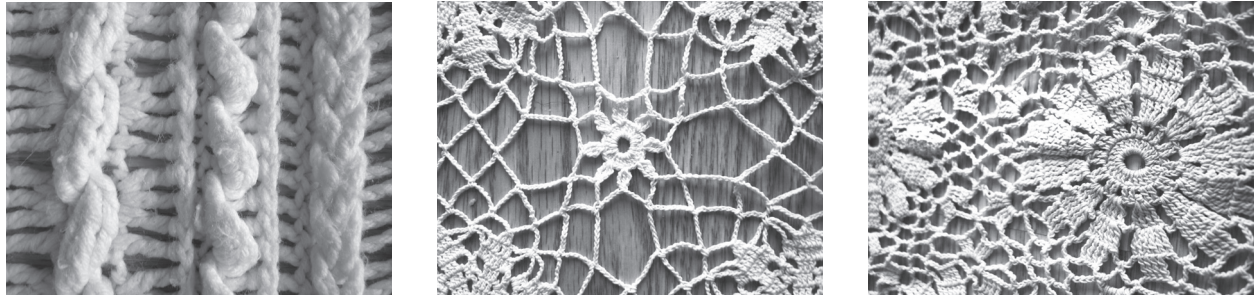

Fig. 7.2

balance between bottom-up and top-down. Knitting and crocheting require a constant dialog of part (stitch) to whole (product). When knitting and crocheting, it is not always necessary to use patterns to arrive at a finished product. There are some who prefer to knit or crochet using only their judgment to design an article. Many find this difficult because it requires a constant dialog between the incremental process of each loop and the final outcome. One must constantly imagine the completed object and adjust each subsequent loop to be successful in fabricating their desired intent. This method of pattern-free knitting and crocheting is commonly known as freestyle.

“You can follow a set pattern - an algorithm - in order to achieve a certain form. You can also accidentally, or purposefully-accidentally add a stitch or drop two - these ‘mistakes’ all affect the final form, and is one of the more interesting, human elements of the exercise.” (Jessica In, E-mail to A.G.W)

Growing interest in freestyle knitting and freestyle crocheting can be attributed to the work of a professor of mathematics at Cornell University - Daina Taimina - who has sparked the imaginations of mathematicians, artists, and grandmothers alike.

Hyperbolic Crochet



Fig. 8.1

In 1997, Daina Taimina was studying how to model complex mathematical structures, namely hyperbolic geometry. Hyperbolic geometry is a non-Euclidian geometry that satisfies all of Euclid's postulates except for the parallel postulate.

Euclid asked, if a line and a point outside the line is drawn, how many lines can be drawn through a point without intersecting the existing line? The answer: one (*Fig. 8.2*) Later mathematicians asked this question of spherical space, in which the number of lines that can be drawn without intersection is zero. In hyperbolic space, the answer to this of intersection is infinity. (*Fig. 8.2*) Many mathematicians of the early 19th century were troubled with this proposal. The parallel postulate as it pertained to Euclidian space was easily understood and diagramed in two dimensions. Spherical space was accessible by diagramming the postulate on a sphere, however, there was no physical model to prove the parallel postulate in hyperbolic geometry.

In attempting to find a way to model this theory, Professor Taimina began knitting. She quickly found that knitting was too difficult to control as there are too many loops to account for. She realized that crochet was the appropriate technique to use. Unlike the parallel process in knitting, crochet is a serial technique, meaning one loop is constructed at one time. This control enabled Professor Taimina to carefully execute the formula of the hyperbolic plane, crochet 3 loops, increase 1 loop. This physical crochet model of hyperbolic space is a tactile manifestation of a complex mathematical theory, aiding in the comprehension of hyperbolic space. By stitching parallel lines on the crochet model one can prove that these lines do not intersect.

Euclidian Geometry



Spherical Geometry

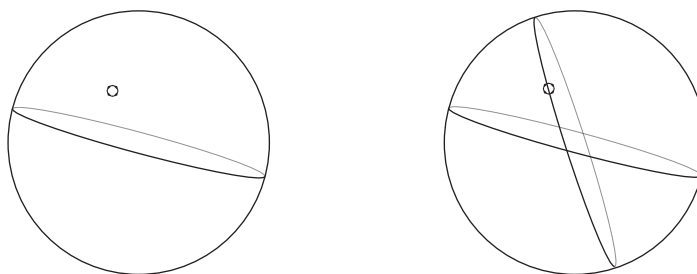

Hyperbolic Geometry



Fig. 8.2



Fig. 8.3

Pattern Generators

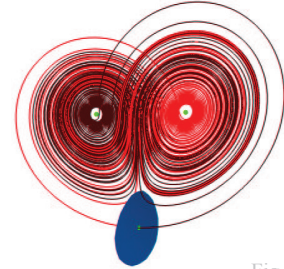

Fig. 9.1

Daina Taimina showed how crochet can be used to prove the otherwise impossible model of hyperbolic space. The establishment of crochet as a modeling tool for hyperbolic geometry has sparked a great interest in this domestic feminine art. A great proponent of hyperbolic crochet is Margaret Wertheim, the founder of The Institute for Figuring in Los Angeles. The Institute specializes in the further explorations of hyperbolic modeling through the medium of crochet. In recent years a great interest in crochet can be credited to Ms. Wertheim with her willingness to promote discovery through physical modes of play.

At the University of Bristol, Dr. Hinke Osinga and Bernd Krauskopf were studying the Lorenz manifold. The Lorenz manifold is a model describing the nature of chaotic systems like dynamic weather, founded by the meteorologist E.N. Lorenz in 1963. Dr. Osinga and Professor Krauskopf were able to develop algorithms, with aid of a computer, that expresses this chaotic system in terms of vectors. This enabled them to visualize the system, even though a physical model of the manifold did not exist. In December 2002, Dr. Osinga, who had been crocheting from a young age, was working on a hexagonal lace motif when Professor Krauskopf asked, “Why don’t you crochet something useful?”

“The algorithm we developed ‘grows’ a manifold in steps. We start from a small disc in the stable eigenspace of the origin and add at each step a band of a fixed width. In other words, at any time of the calculation the computed part of the Lorenz manifold is a topological disc whose outer rim is (approximately) a level set of the geodesic distance from the origin. What we realized then and there is that the mesh generated by our

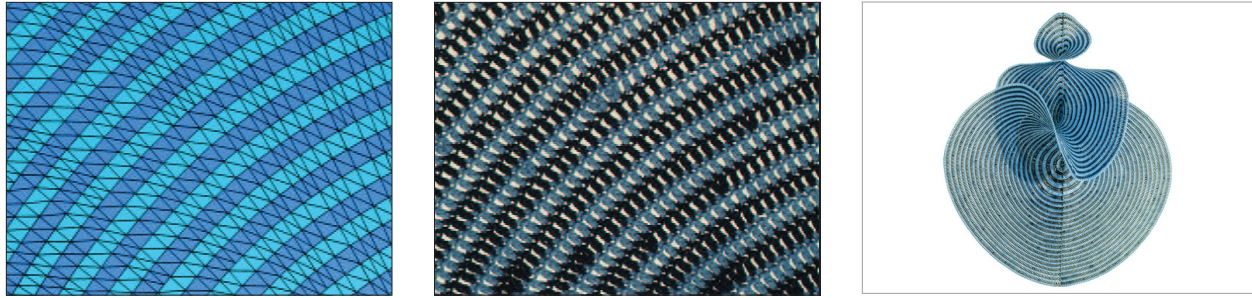

Fig. 9.2

algorithm can directly be interpreted as crochet instructions!” (Osinga, I, Crocheting the Lorenz Manifold)

In an effort to realize the complex mathematical systems within chaos theory, mathematicians turn towards crochet as a means to do so. Although, not all patterns are generated from the desire to realize a mathematical model. In one instance, crochet is used as a vehicle to experiment with elaborate construction methods through the use of digital computation and physical execution. One such project is the Crochet Pattern Generator by Matt Gilbert.

With a post-graduate degree in Human Computer Interaction at Georgia Tech, Matt Gilbert wanted to explore the possibilities between digitally generated patterns and physical making. He was intrigued by the use of crochet in the research done at the Institute for Figuring. Mr. Gilbert wrote a digital script, a set of rules, that can be applied to a given form.

“The program is a design interface that takes a given form, in this case a sweater, and allows me to draw and generate crochet patterns in the “sweater space”. The resultant pattern is too complex to follow as you would a normal crochet pattern, so once a pattern is generated, I can go back through it with the program and follow along step-by-step as I crochet.” (Gilbert, Crochet Pattern Generator)

Gilbert’s work stems from a long history of computation and textiles processes, from the Analytical Engine of Charles Babbage to the Jacquard Loom of 1801. The

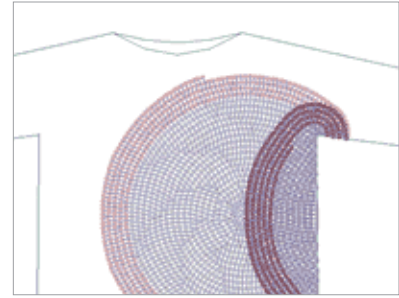

Fig. 9.3

Jacquard Loom (*Fig. 9.4*) enabled complex and elaborate patterns to be constructed over and over with great accuracy. This great invention separates the fabricators judgment in the process of making the product.

In attempts to define the different method of working, the English architect and woodworker David Pye coined two concise terms within the context of making. Pye suggested that there were two distinctly different types of workmanship: one of Risk and the other of Certainty. Risk and certainty does not delineate the difference between whether something is made by man or machine. Instead, it is defined by chance that exists in a technique or process. Pye defines workmanship as:

Workmanship of Risk - Individual production, unpredictable (risky), Production by skilled person(s)

Workmanship Of Certainty - Mass Production, Predictable, Production by a system (Press, 262, Neocraft)

This clarification is important in understanding a way of working. In the digital age, computers are being used to eliminate the human hand, to remove his judgment and the risk involved in order to arrive at a clear and predictable outcome. Risk can only be mediated or reduced by the skilled worker and his judgment. Pye explains,

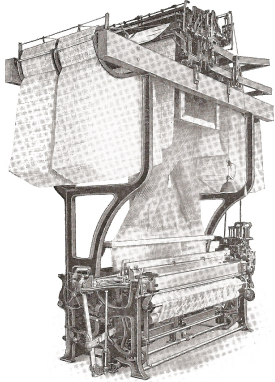

Fig. 9.4

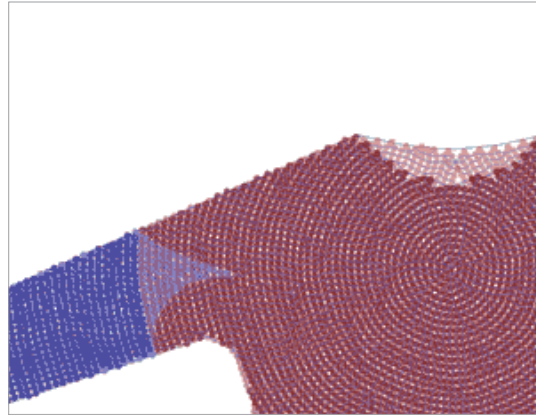

Fig. 9.5

that even when working with machines, as with cutting wood on a table saw, though the machine may be precise, risk still exists. The hand that guides the wood past the blade holds the chance that the pressure of the wood on the fence may not be uniform throughout the cut. Gilbert's project becomes the embodiment of both risk and judgment by using the digital tools to compute a complex pattern, which is then executed by hand. In construction, the predictable pattern is translated through crochet into a workmanship of risk. Though chance is minimized through the use of the pattern, each time Gilbert judges and checks each step. He is always active in the creation of the sweater. The Jacquard Loom was one of the first steps towards a workmanship of certainty and the removal of judgment during the process. However, no matter how refined the automation of a machine becomes, risk and chance will continue to exist. The analog crochet technique does not try to eliminate risk or judgment instead it embraces both during the process.

The technique and final product of crochet is intimately tied to its construction. This is no more true than in freestyle crocheting. This method fully embraces judgment in the process, this allows the opportunity for discrete modifications by the fabricator. This method of crochet requires the constant dialog between each stitch and the final product. Through playing with the technique, one can gain a deeper insight into the structure of crochet.

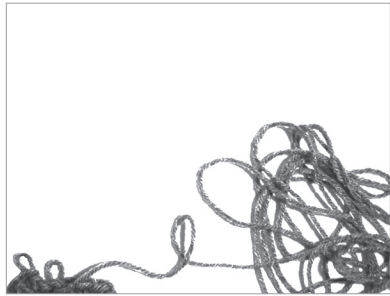
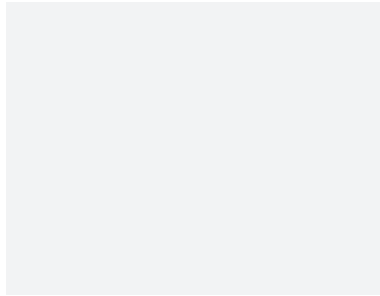

Fig. 10.1



Topology

Learning how to crochet is a daunting challenge to many. Though, skilled fabricators use complex patterns or invent their own through trial and error, the basic technique is simple. Crochet is done by the looping of thread on itself to create a product. The thread can be manipulated, twisted, or crossed on itself. Because of this, crochet is not geometric. Crochet enables manipulation and deformation to occur while maintaining its basic structure of a looped thread. It is a topology and not a geometry. Topology is the study of properties that are preserved through deforming, twisting, and stretching of objects. Tearing is not permitted. This is especially true for crochet because if a tear is made, the entire system will unravel.



Fig. 10.2

To aid in the understanding of topology, a circle can be stretched into an ellipse, though a different geometric figure, the circle and ellipse are still topologically the same. Another example is the famous donut and coffee cup parallel. A donut, or

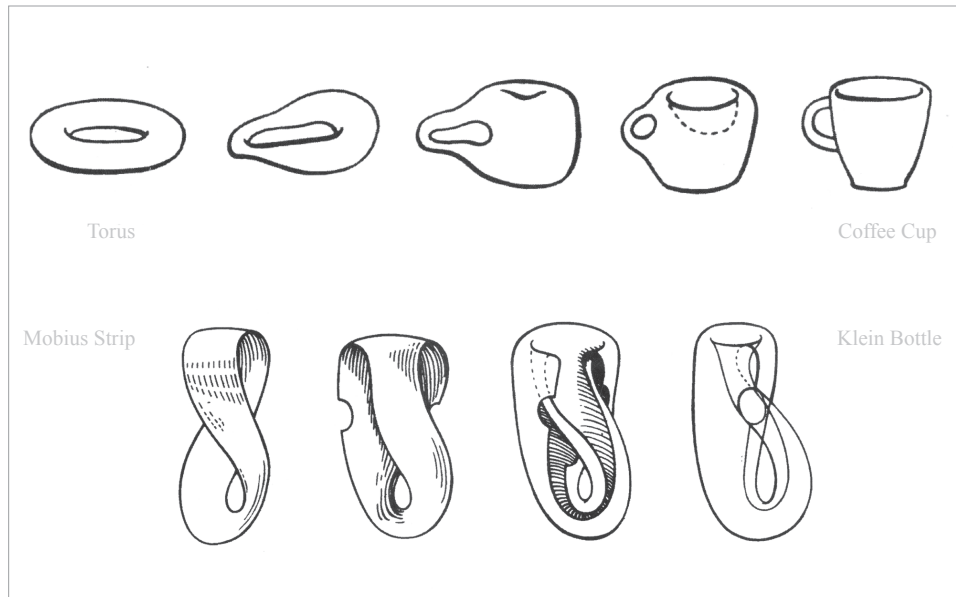
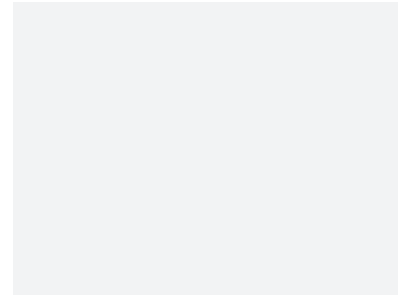
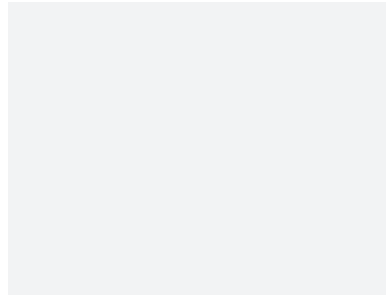

Fig. 10.3

torus, is topologically the same as a coffee cup. (*Fig. 10.3*) Though the cup may be a container, topologically both torus and coffee cup only have one opening, this opening is found in the middle of the torus and in the handle of the coffee cup.

The topology of any crocheted object, from a geometric figure to a hat or a sweater, remains the same as it is created with a thread that is looped, twisted, and deformed into its given form. Through the twisting and looping, crochet can construct beautifully articulated surfaces and objects which will always remain - whatever the configuration - a thread. In actively looping the thread to create a surface or shape, one begins to understand that, no matter what form the crochet takes on, the thread remains topologically unchanged.



Learning the Technique

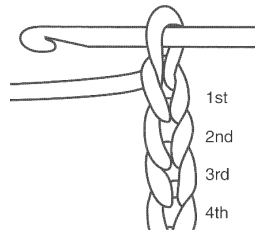

Fig. 11.1

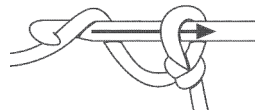

Fig. 11.2

To begin any crochet project a chain of loops must be started. A chain is a series of loops lined together in a single row. (Fig. 11.1) To initiate the chain, begin with a single slip knot over the hook. Bring the yarn over the hook (Fig. 11.2). The yarn is then pulled through the initial slip knot to yield one stitch and a single slip knot. In patterns, this first knot in the chain is abbreviated as *ch*. The crochet hook is now running through the first chain stitch (Fig. 11.1).

This chain is the base for pattern and freestyle crochet. In order to create a surface, the base chain is doubled back on itself and new stitches are made by hooking back into the base chain. There are three different methods for doubling back, affecting the structure, shape, and aesthetic of the overall form. Choosing the desired method is critical in setting up the overall structure and intent of the final outcome. When working with a pattern or freestyle crocheting certain stitches must be used. There are variety of different basic stitches that can be used. Each stitch yields a slightly different effect. Base stitches can be used in combination with others and in multiple configurations to arrive at varying patterns.

Many fabricators will use patterns from books and websites to make garments or other items. This simple technique of looping thread leads to a variety of different thread structures, surfaces, and textures.

Method 1: *Fig. 11.3*

The crochet hook is inserted under the top two stands of each stitch in the base chain. This will create a tighter structure between each row.

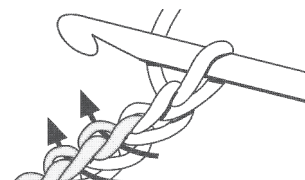

Fig. 11.3

Method 2: *Fig. 11.4*

The crochet hook is inserted into the back ridge of each stitch in the base chain. This will create a loose structure between each row.

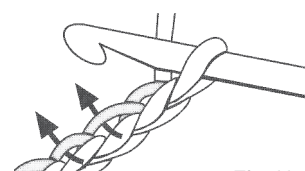

Fig. 11.4

Method 3: *Fig. 11.5*

In forming a ring, work the specific number of chains and join them to the first chain made with a stitch.

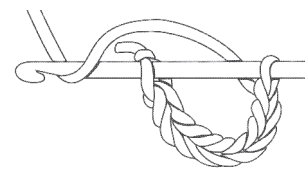

Fig. 11.5

Slip Stitch (slip st):

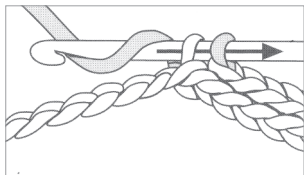

Fig. 11.6

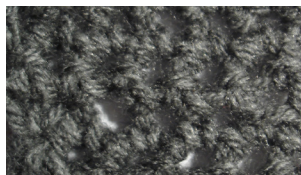

Fig. 11.7

Single Crochet (sc):

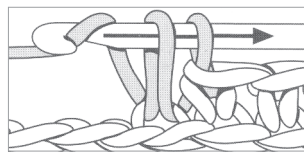

Fig. 11.8

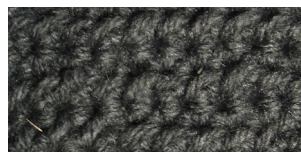

Fig. 11.9

Half Double Crochet (hdc):

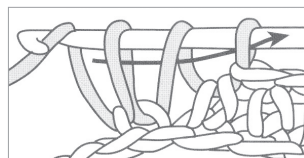

Fig. 11.10



Fig. 11.11

Double Crochet (dc):

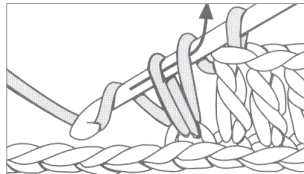

Fig. 11.12

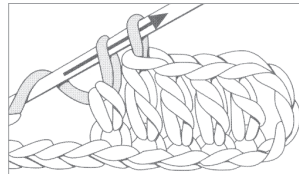

Fig. 11.13

Treble Crochet (tr):

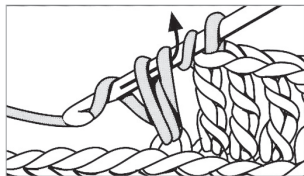

Fig. 11.14



Fig. 11.15

Double Treble Crochet (dtr):

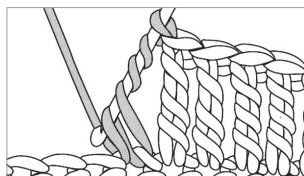

Fig. 11.16

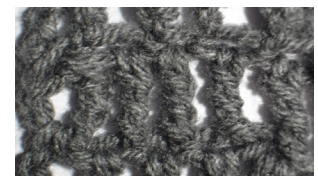
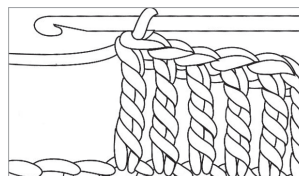

Fig. 11.17

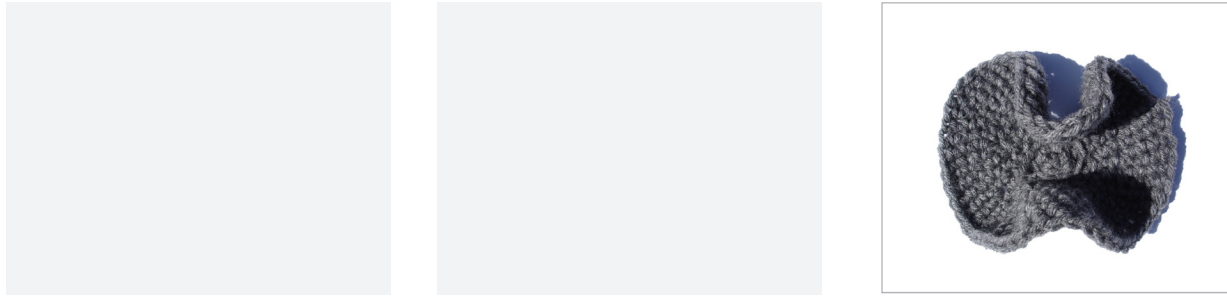

Fig. 12.1

Understanding Crochet

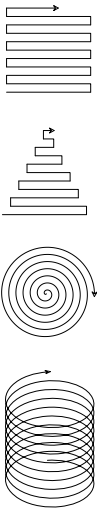

Fig. 12.2

In order to fully understand both the technique and structure of crochet, one must learn how to construct simple shapes. By selecting between the simple stitches and the three base methods of making a chain, one needs to construct a Square, Triangle, Circle and a Cylinder without the use of a pattern. By doing so, ones thinking must change, as the act of making is directly relative to the final outcome.

Through the active construction of these figures, one begins to see the structure of the crochet. During the process of constructing the square and triangle the movement of piece and the crochet hook take on a pattern. The square and triangle are both constructed by doubling back on each row of chains; this results in a zigzag (*Fig 12.2*). The spine moves back and forth in each row, doubling back on itself. The zigzag is the pure expression of the process in which the product was created. The process of construction is embedded into the item. The circle is different - its internal structure does not zigzag, it spirals. Beginning with the four chains of the granny square and moving outwards, the circle will always have a loop at the



Fig. 12.3

end, that will never tie back into the overall figure. Like the circle, the cylinder is constructed by means of revolving around the base chain, creating a helical structure. And like the circle, the helical structure will always leave an end that will never tie back into the overall figure. The active process becomes expressed by the internal structure of the crochet, embodying both action and method.

This exercise in crochet exploits the internal structure of each figure. Though, these figures may be labeled as a square, triangle, circle and cylinder, they are not geometric. These figures are not Euclidian geometry. Rather, they are representational of these geometric figures. The square is not a square; the lengths of each side is not equal to one another as it is made of yarn and is flexible. This is true for the triangle, circle and, cylinder. These figures are not geometries - they are a topology.



Fig. 12.4



Fig. 13.1.1

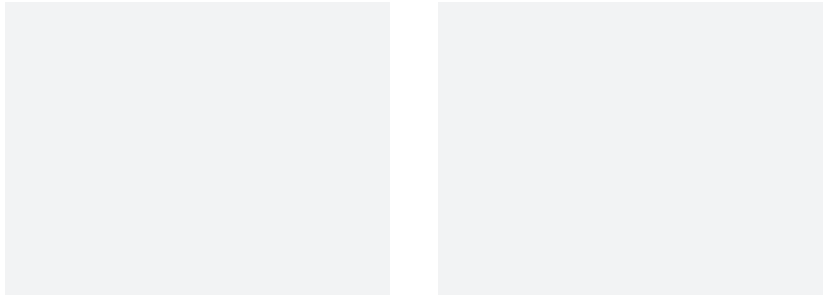

Explorations: Media

“The physical experiment as a method for acquiring knowledge of scientific relationships, has not lost its importance...By using so called analog models which use physical properties of a system matching the problem in question for its solution, complex problems can be solved by observing a system which reaches a state of equilibrium” (Gaß, 1.4, IL 25)

To learn more about what a technique can achieve, one must begin to play with and explore the technique. Explorations can lead to greater discoveries and otherwise previously unknown insights. Through exploration one begins to realize that the material employed is not defined by the technique. Any material with similar properties to thread can be used in weaving, macramé, braiding, and especially crochet.

Any designer, craftsman, or artist familiar with crochet will say that the material used directly influences the end product. Multiple types of yarn have been developed for specific purposes. One can begin to play with different types of yarn weight in order to arrive at the desired texture and appearance. Basic yarn weights vary from fine (*socks*) to worsted (*sweaters or afghans*) to bulky (*jackets*)



Fig. 13.1.2



Fig. 13.1.3

and coats). Crocheting is not specific to the use of yarns. Changing the material can drastically alter both aesthetic and overall form. There are a number of active fiber artists who have experimented with different material and scale in textiles. The artist David Cole has hand knit fiberglass building insulation into the form of a teddy bear as well as knit an American flag with the use of two back hoes and heavy gauge material. In continuing explorations of scale, Kwangho Lee uses thick plastic tubing, which he loops into functional furniture and pendant light fixtures (*Fig. 13.1.2*). The fiber artists, Rockpool Candy, and Kate Pokorny have used large scale materials to construct habitable structures. By using plastic tubing, Rockpool Candy uses her entire body as the crochet hook in order to construct each loop (*Fig. 13.1.4*). Kate Pokorny has embarked on the exploration of crochet as structure. By hand felting cording 1.5 - 2 inches in thickness, she has begun to construct a nomadic hut, called a Yurt, used by the Mongolians. In her explorations of scale she realized that if the material was thick enough, when crocheted, the result was structural. (*Fig. 13.1.3*) These experiments in scale not only alter the size of the crochet, but can begin to communicate new possibilities and uses of the textile technique.

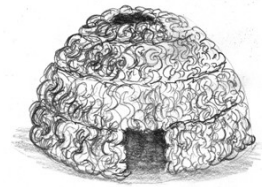

Fig. 13.1.4



Fig. 13.1.5



Fig. 13.2.1

Acrylic

In wool crochet, it is difficult to determine where one loop ends and the other begins. In acrylic the crochet stitch is highlighted by the material and its properties which can drastically change the overall aesthetic of the crochet. Its glossy finish articulates each individual crochet stitch and frames the negative space defined by the crochet.



Fig. 13.2.2



Fig. 13.3.1

Sisal

Crocheting sisal is challenging as the frays tend to get caught by the crochet hook, pulling only a portion of the sisal through the loops. The material begins to affect the process, yet it is as flexible as wool allowing for complex stitches to be used. The final product looks much like that of the wool yarn. The overall crochet of sisal mat seems to have tighter stitches and, due to the frays, the final product is visually fuzzier than the same piece done in wool.



Fig. 13.3.2

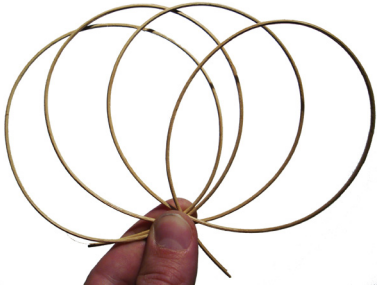

Fig. 13.4.1

Rattan

When dry, rattan is brittle. In order to make the crochet loop the fibers must be soaked in water. Once the fibers have been soaking the rattan bends easily without breaking or fraying. This gradual drying of the material programs the rattan into its new looped curvature. Once the water has evaporated, the rattan crochet tube is no longer as pliable or ductile as it was when wet. The rigidity of the crochet structure comes from the stiffness of the material, the configuration of the crochet loops and the shape of the object, a tube.

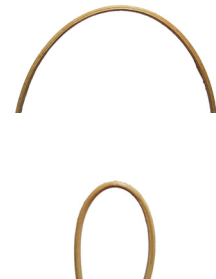

Fig. 13.4.2

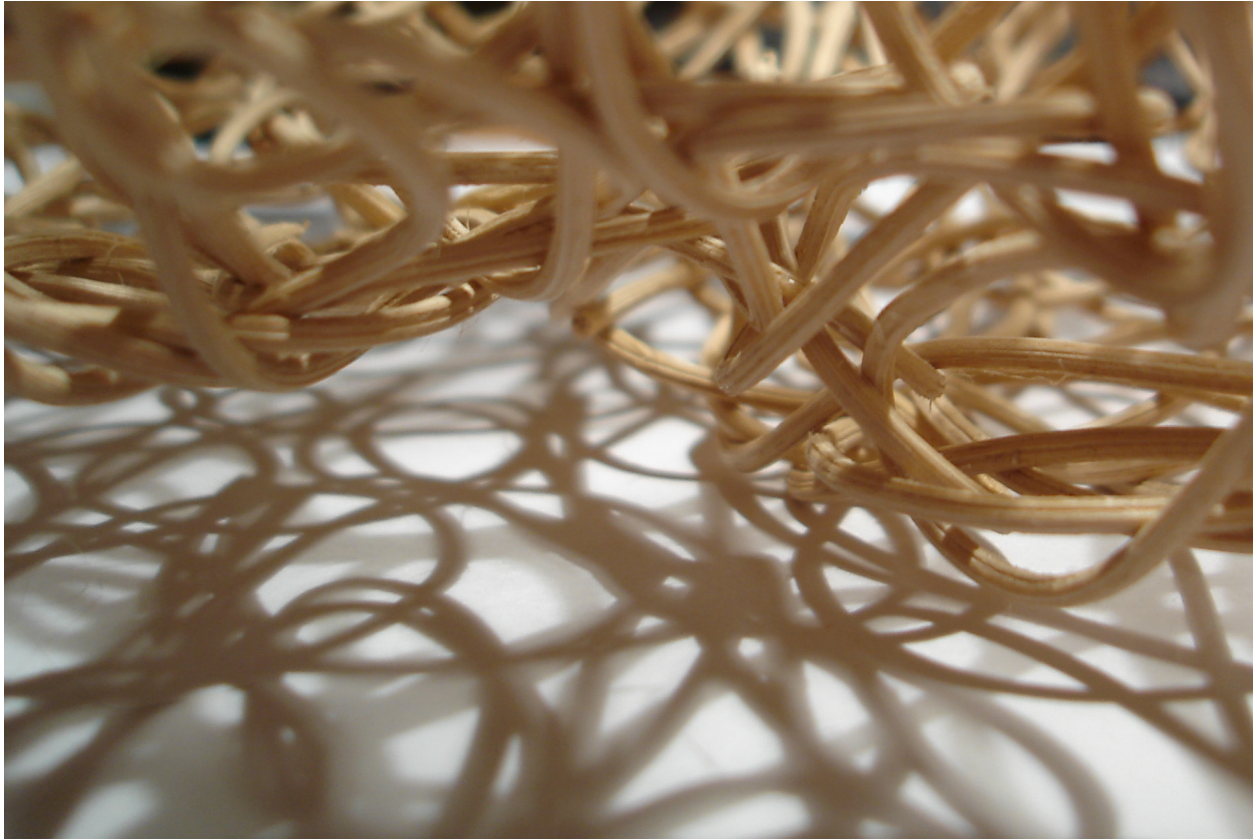

Fig. 13.4.3



Fig. 13.4.4



Fig. 13.5.1

Manila

With the manila rope, it is difficult to complete tight, complex stitches, so a simple slip stitch is used. The rope begins to dictate what method of crochet can be achieved; this is due to the material's stiffness. This jump in scale offers a dramatic increase in depth of the crochet stitch. This increase in depth and the stiff quality of the manila rope, starts to translate crochet from a surface, into a self supporting surface, similar to Kate Pokorny's Yurt. This depth and curvature of the surface enables the system to be self supporting.



Fig. 13.5.2

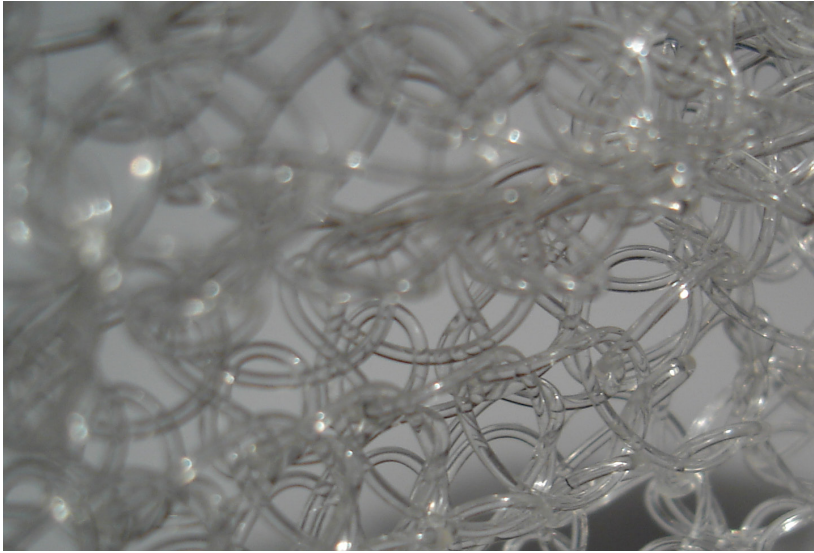

Fig. 13.6.1



Fig. 13.6.2

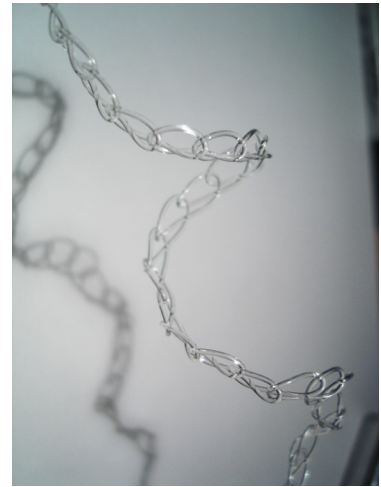

Fig. 13.6.3

Fishing Line

The greatest difference from the other media is that the fishing line is coiled around a drum. Because of this, the material has a memory. The fishing line may be straightened but it will spring back into a coiled state. The embedded memory of the coil begins to affect the crocheted chain. The chain coils on itself, resulting in a helix.

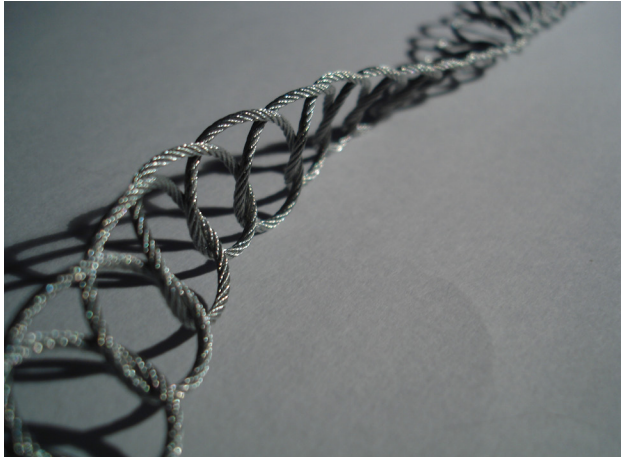

Fig. 13.7.1

Steel Cable

Like fishing line, braided steel cable is coiled around a drum. Therefore the initial crochet chain forms a helix. The steel cable acts similarly to the fishing line regarding material memory, however it has similar characteristics to rattan, in that a tight stitches are difficult to execute.

Crocheting different types and sizes of material gives rise to unexpected results. As the material becomes larger, the crochet hook is no longer as effective. It becomes necessary to loop the material by hand, or in some cases using the whole arm. Because of this, the more complex stitches like a double crochet or treble stitch are difficult to make. Less complex stitches are employed in order to crochet material like rattan, manila rope and steel cable. This exploration in media begins to show how changes in materiality can directly affect both aesthetic and final outcome.

These explorations look at substituting one material for another. In changing a



Fig. 13.7.2

material property or its scale, the process and overall form are changed. In order to achieve a desired result, the fabricator must work with the material. A material may not allow for certain techniques to be used due to its stiffness or length, in some cases, external agents must be used, as with the rattan. By adding water, the rattan began taking on different properties. The plant fibers soaked up the water, which resulted in fiber that was no longer stiff but flexible. This enabled the rattan to be looped and twisted into a crocheted system. As the rattan began to dry, the fiber became stiff again, but stiffened in its new form. The addition of an agent can change the properties of a material in order to achieve a desired result.



Fig. 14.1.1

Explorations: Stiffening Agents

In the first experiment in stiffening, two identical squares are crocheted from wool thread into square figures. One is immersed into a slurry of Plaster of Paris and the other into lacquer, fully coating both pieces. Both crochet figures are removed and left to dry. (*Fig. 14.1.2 & 3*)

Once cured, the examination of the two swatches leads to two very different outcomes. The plaster figure is completely covered. No threads or thread fibers are visible, the only property of the crochet remaining is the faint texture of the stitches. The openings in the figure are completely filled in and the system is no longer flexible. Like any plaster surface, it is stiff and no longer ductile. The plaster not only covers the exterior but embeds itself into the fibers and is reinforced by the thread.

The lacquer swatch is drastically different from its plaster counterpart. The lacquer swatch remains visually unchanged. The color and porosity are unaffected by the



Fig. 14.1.2

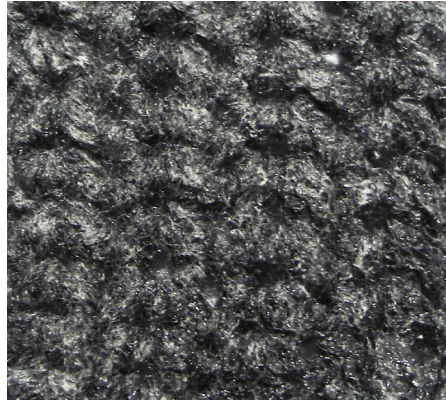

Fig. 14.1.3

lacquer. Although, the internal properties of the swatch have been dramatically altered. The lacquer embedded itself between the thread, thus changing the internal structure of the thread and crochet stitch. The lacquer swatch can no longer be stretched as the fibers and loops remain bonded together. Even though it no longer stretches, unlike the plaster swatch, it can still deform and fold on itself.

The addition of the lacquer agent changes the material properties of the wool thread in its looped configuration. Due to the bonding of the fibers, the lacquer makes the figure semi-rigid while remaining flexible. When force is exerted on the lacquer figure, it bends and folds on itself, but when the force is removed, the lacquer swatch returns to the previous shape. The lacquer has given a material memory. Each time a force is exerted on the swatch, the bonds between the fibers pull and in some cases break. Therefore, the more it is folded, the more flexible it becomes.



Fig. 14.1.4



Fig. 14.1.5



Fig. 14.1.6

Similar to plaster, the ceramic experiment results in a stiff, static product. In a continuation of experimentation with stiffening agents, a clay slip is used. Crocheting large nets with a thin acrylic thread, each net is immersed into a clay slip. As the clay begins to dry, and the water evaporates from the mixture, additional layers of slip are applied. These layers begin to increase the thickness of the clay surrounding the threads. Unlike the plaster swatch, the crochet surfaces used a large stitch that created large openings. The slip covered the surface of the threads but the openings remained. As additional layers of slip were applied, the thickness of the threads increased, and the openings decreased.

Once the entire system was allowed to dry completely, the product was fragile. In order to strengthen the clay, it needed to be fired in the kiln. During this process, the clay is superheated, removing all traces of water. A result of this process is

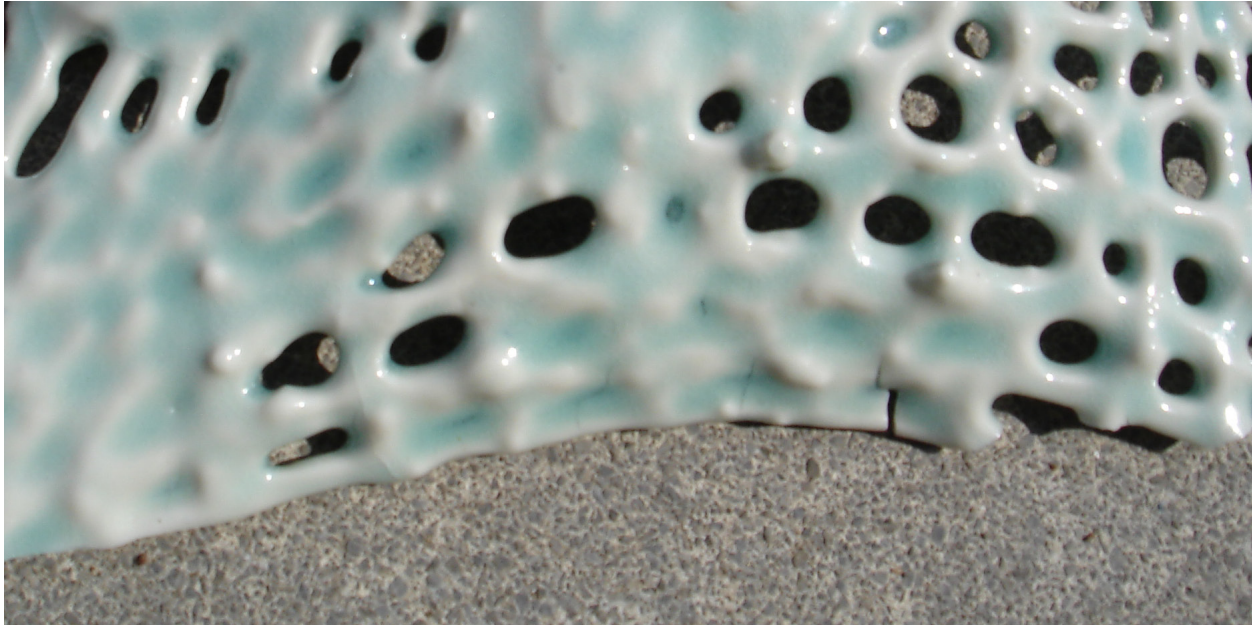

Fig. 14.1.7

the burning off of the internal crochet threads. When removed from the kiln, the resulting artifact is no longer crochet, only the hardened clay remains. Though hard, the ceramic crochet still holds the same properties of the thread crochet.

The exploration of stiffening agents has come to define that once a material has been crocheted, its material properties can still be affected by the addition of a liquid agent. Once hardened, the crochet can no longer be unraveled, pulled or stretched. However, the ceramic crochet remains topological. The clay slip deforms the gauge of the thread and the openings within the net structure. Only during the translation from the analog model into the digital does the topological crochet move into a geometry.

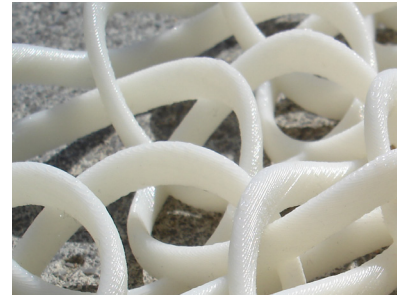
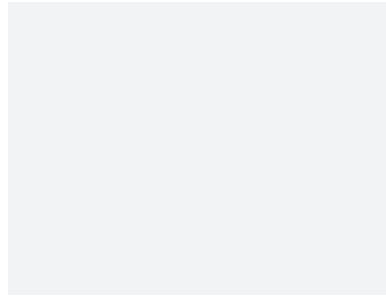
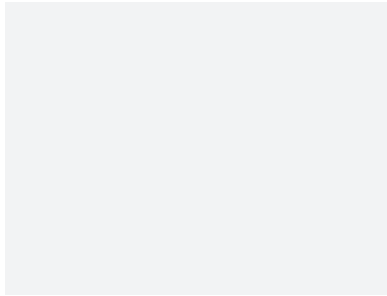

Fig. 14.2.1

The Digital Stitch

“Virtual Space becomes an arena for speculation and contemplation, for testing, turning, warping morphing and animating spatial sequences that otherwise would remain static graphic images. (The) digital space becomes a contributor to the development of ideas and forms, not merely a passive host to preconceived shapes or prescribed software formats and output” (Dollens, 9, D2A)

The introduction of digital computing has touched every aspect of our lives. Digital modeling has become the norm in design schools and the profession. However, textiles techniques like crochet have resisted the automation through machinery and computing. This complex technique has remained a tactile art since its discovery. Despite this, contemporary computer modeling and digital computing are coming ever closer to digitally replicating textiles. The use of digital and parametric modeling tools are enabling the scripting of digital relationships. The desire for exploration and translation of an analog technique into a digital construct is not specific to textiles. One of the first translations of an analog modeling technique into a digital tool was the spline.

With the advent of the automobile, the use of splines became an industrialized process. This required a new kind of spline, a digital one. Known today as Bezier Splines, B-Splines and also NURBS (Non-uniform rational B-spline). The Bezier

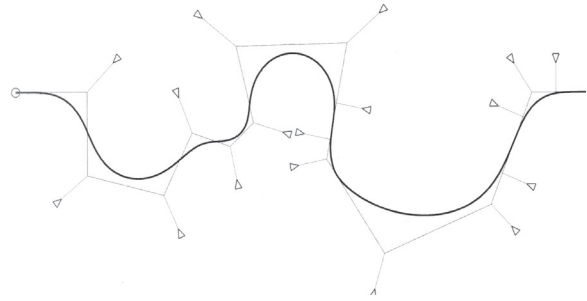
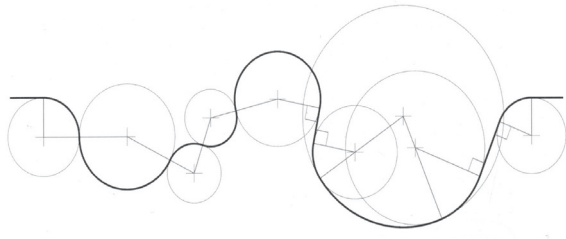

Fig. 14.2.2

spline was developed by the French mathematician and engineer, Pierre Bezier who worked for the car manufacturer, Renault. In the early 1960's, Bezier began looking into computer-aided drafting and computer-aided manufacturing or CAD/CAM technologies. Bezier understood the benefits of working with splines. However, in the industrial process of automobile manufacturing, working with an analog or physical spline was too risky. Instead, he enlisted the computer. The digital spline is no longer based on natural laws. Rather, it is based on mathematical averages of control points. (Fig. 14.2.2) These control vertices, allow for, just as with shipbuilders, the ability to carefully craft a spline into the desired curvature. By using the digital, the spline could now be repeated and copied with great accuracy. In *The Architecture of Continuity*, Lars Spuybroek identifies that a digital spline starts out straight, its curvature changes as the CV's are altered and moved. When working with a geometric straight line that travels from point A to point B, the change of either point only results in the rotation of the line. However, when points along a spline are altered and moved, the spline's pre-structuring of CVs allows for the deformation of the spline.

In order to translate a physical crochet into the digital environment, the structure of the crochet loop must be diagrammed and carefully crafted through the use of splines. This requires the crochet chain to be broken down into its simplest form, a single loop. In order to accomplish this, the single loop is diagrammed in the base

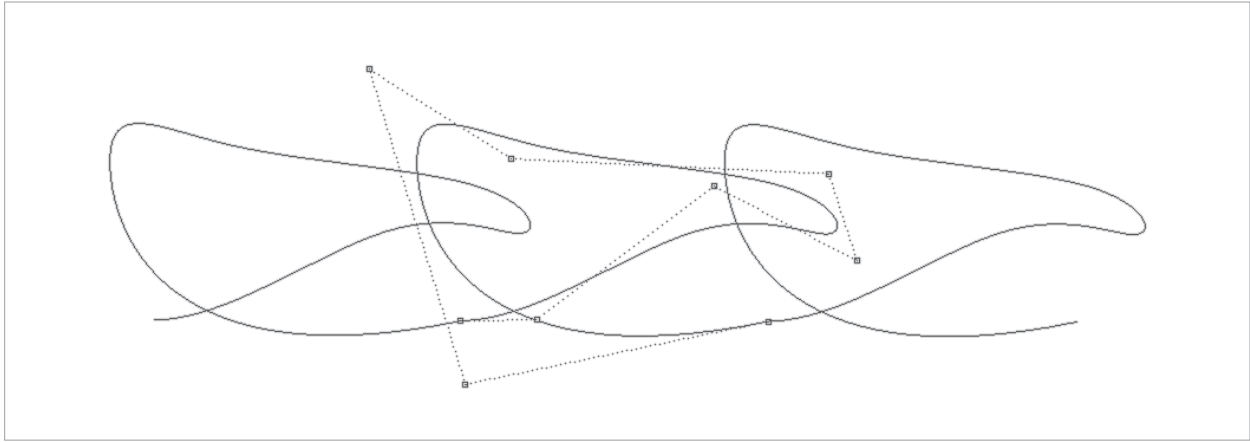

Fig. 14.2.3

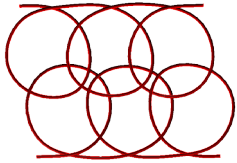

Fig. 14.2.4

chain using the physical thread and carefully reconstructed digitally by following the thread as it bends, folds, and loops back on itself (*Fig. 14.2.3*).

The digital modeling software, Rhinoceros 3D, enables the accurate reconstruction of the three dimensional path, that creates a crochet loop. Rhino is a NURBS-based modeling program. A more developed spline than that of Bezier but still utilizing the same principles. A NURBS spline allows for the careful manipulation of itself and responds similarly to a material spline. By moving the control vertices, or CVs, of the digital spline, the loop can be drafted in plan, then the CVs are pulled upwards in the Z plane to create the overlapping path of the thread (*Fig. 14.2.3*).

The construction of a single looped spline cannot be created on its own. In order to build the base loop, it must be constructed within a chain. Therefore, the base loop needs to be copied then translated into a continuous chain of the loop module. This is required because the repeated module must loop in and around each loop without intersecting in order to properly craft the digital loop. The construction of the digital loop can only be accomplished by trial and error, carefully assessing the interactions between the repeated and rotated loop module.

Once the base loop module has been successfully crafted, it is then arrayed into

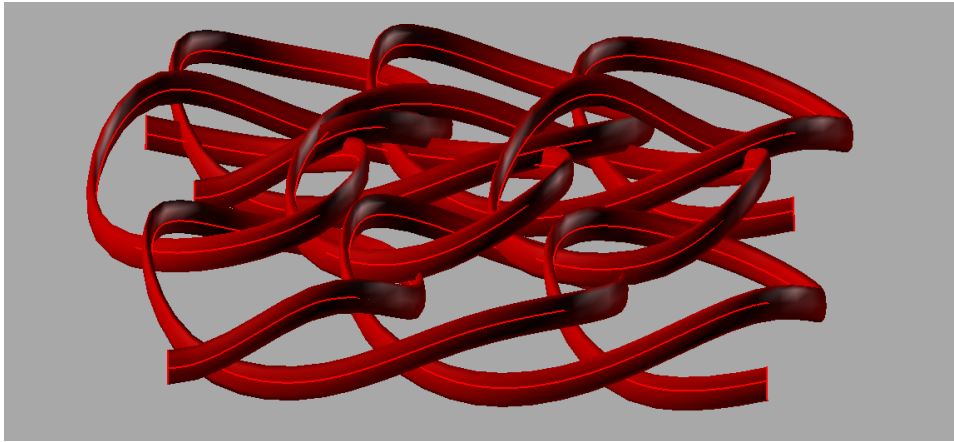

Fig. 14.2.5

a chain. That chain is copied, then rotated 90 degrees and offset. (*Fig. 14.2.4*) This rotation and offset of the second chain begins to take on the configuration of a slip stitch. Once rotated and repeated over and over, each chain of splines can be joined. This linked chain of splines can now be thickened. By using a pipe command, this constructs a tube with a thickness that is defined by the designer.

This digital slip stitch is not physical nor is it constructed in a specific material. Therefore, the material no longer affects the crochet stitch. It has moved into a workmanship of certainty. By using the software, the digital model can be altered. Because of its immateriality, the risk is minimal, as the digital model is not realized in actual reality. Chance does still exist within the digital model, as emerging qualities from moving, rotating, translating, stretching, twisting, and deforming give rise to unanticipated results. The virtual allows for freedom of exploration, and multiple iterations can be developed within a file. Although these actions only occur to the holistic model, the digital alterations become top-down. In the analog process of crocheting, the fabricator has a great deal of control within each step. Each loop is a discrete decision. The fabricator can decide to drop a loop, add two loops, change stitch types, and each decision directly influences the next as well as the final product. The digital model does not allow for this. Any change or alteration affects only the selected loop and not the whole.

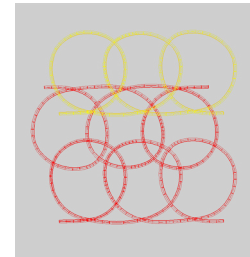
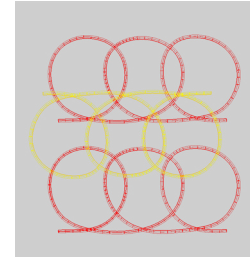

Fig. 14.2.6

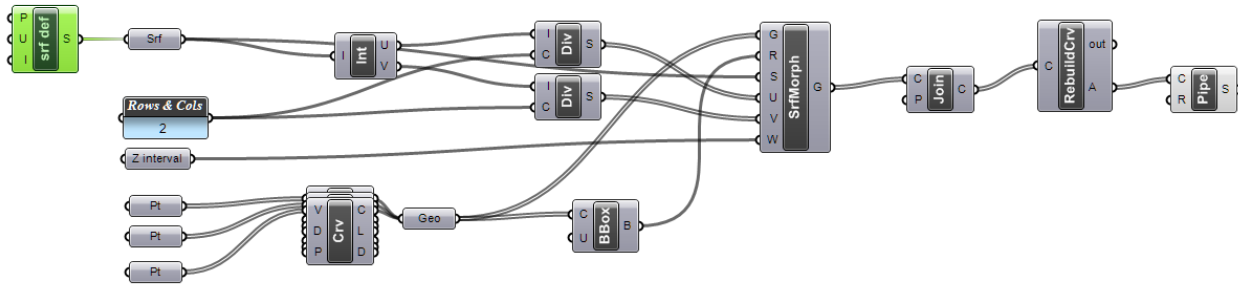

Fig. 14.2.7

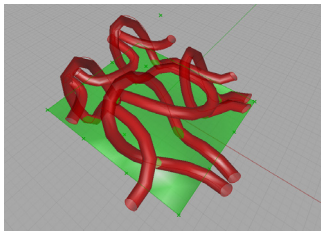

Fig. 14.2.8

The Analog process is truly emergent and that the digital (script) mere replication. In traditional crochet, the (hyperbolic) crochet surface emerges from the equation given by the person crocheting - as stitches are added, they cannot help but push and pull on each other and create a (hyperbolic) surface, unique to the individual crochet-ist. The equation used to crochet can be changed on a whim, resulting in mutants that cannot be replicated. (Jessica In, 2, Plastic Futures 2)

Like the hyperbolic sweater pattern generator, the digital modeled crochet is a static pattern. However, similar to Gilbert's pattern generator, the digital crochet model can be used as a base pattern and applied to a surface. The development of digital programs, and additional plug-ins for modeling software like Rhino, enables the user to create rules and relationships between discrete lines, surfaces, and objects. Generative modeling plug-ins, such as Grasshopper 3d, are developed so the digital model can begin to take on characteristics found only in the analog. By enabling users to script and build relationships, rather than discrete geometries, the digital can begin to take on similar rules and laws of the analog model. The further development of the digital crochet utilizes Grasshopper 3d and a variation on a script defined by Giulio Piacentino.

While visiting his brother in Barcelona, Giulio became enamored in the nets used by the fishermen in the marinas. In an exploration in digital modeling,



Fig. 14.2.9

Giulio defined a Grasshopper script for a knitted surface. He accomplished this by first diagramming the base pattern found in knitting. Once he isolated this base module, he authored a script that arrayed the module of a selected surface (Fig. 14.2.9). This pattern is, like the digital crochet loop, merely a base pattern repeated. Though the result is visually striking, it remains static in both its construction and its process. Unlike the generative nature of the analog technique, the digital must break the concept down into a base module in order to define a developable surface.

(Digital stitch) Once defined, the parameters are not changeable and the process is not emergent. (Giulio Piacentino's grasshopper script) replicates a stitching pattern on top of a predetermined surface. If you can't make it emergent, then you can always fake it. (Jessica In, 5, Plastic Futures 2)

By learning from Piacentino's Grasshopper definition, the scripting of a definition that does not rely on a base pattern, but rather an individual loop is crafted. Unlike the previous digital crochet model in Rhino, the Grasshopper script enables the alteration of each individual stitch over a gradient. Through the addition of another subscript, the deformation of each loop changes gradually based on the location of an assigned point. However, unlike the analog, this digital model is still generated top-down.

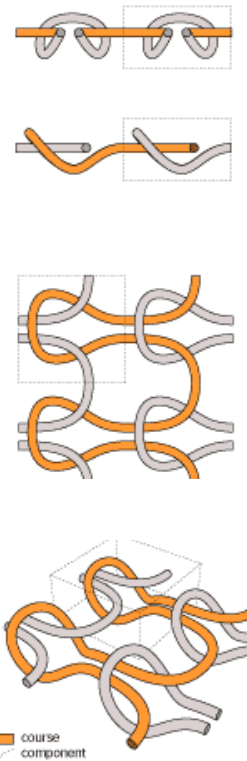

Fig. 14.2.10

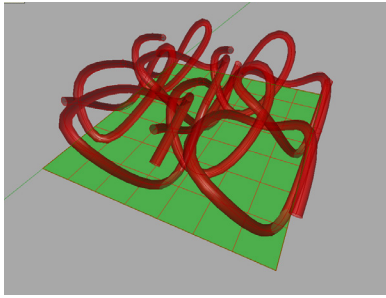

Fig. 14.2.11

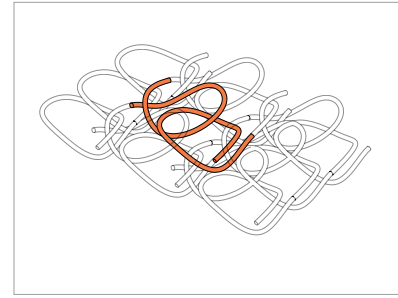
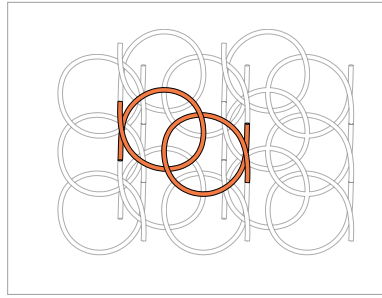

Fig. 14.2.12

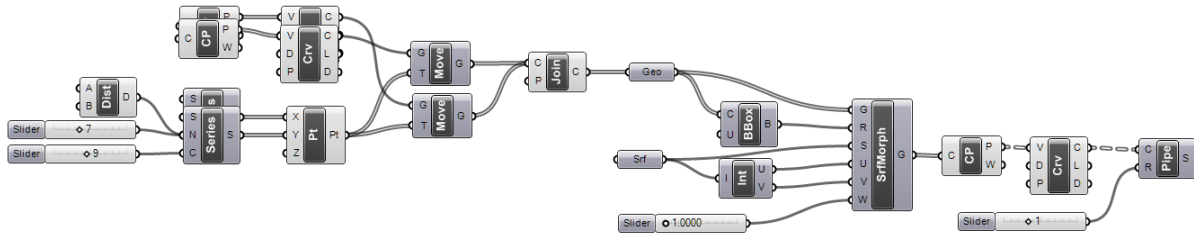

Fig. 14.2.13

The explorations in the digital model are endless. The number of different experiments are only limited to the imagination of the designer. However, the digital experiments run counter to the process of crochet and what one can learn from it. The digital model becomes about the static, the repetitive module and no longer about emergence. The digital stitch, is merely a way to replicate the most basic element within crochet and does not allow the process to affect the outcome. The computer becomes a generator of pattern. In the digital model, the crochet loop is a static geometry devoid of all material and textile properties. Though experimenting with the digital stitch can yield results that might not have been foreseen by the designer, it is no longer a textile technique, the abstraction has moved it into a static geometry.

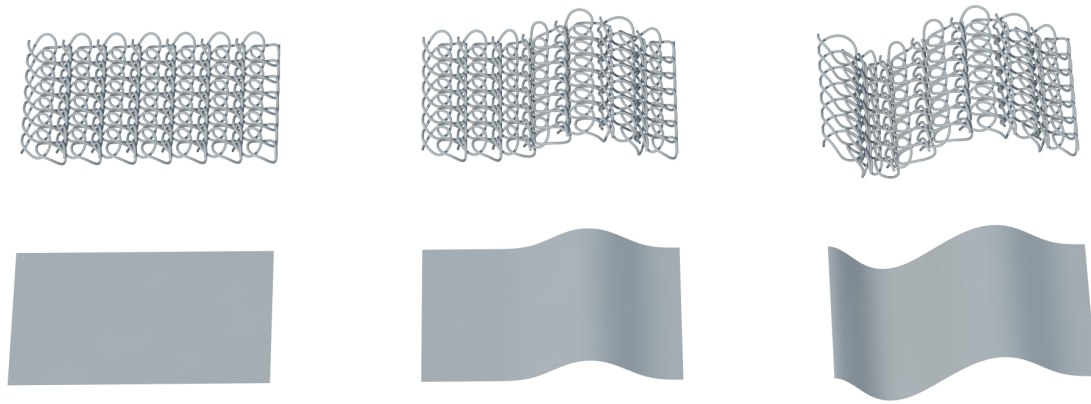

Fig. 14.2.14

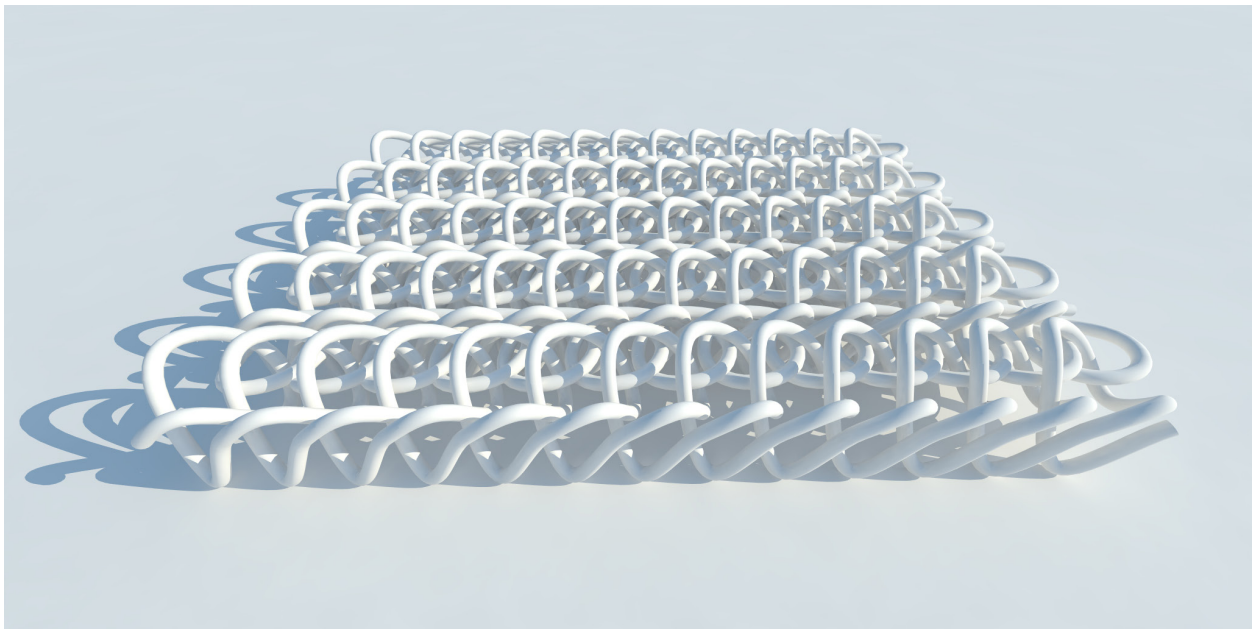

Fig. 14.2.15

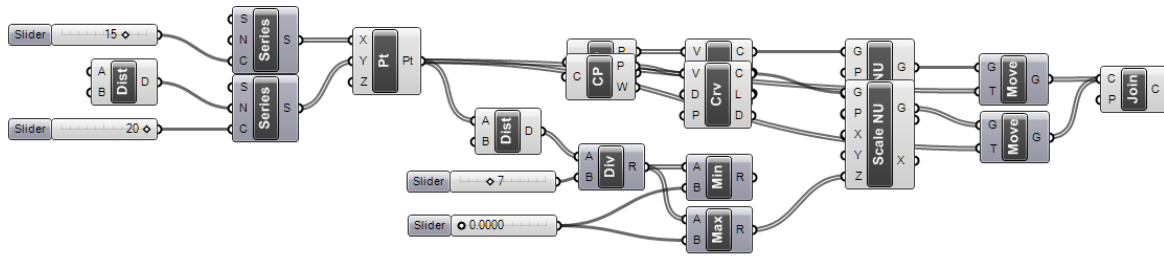

Fig. 14.2.16

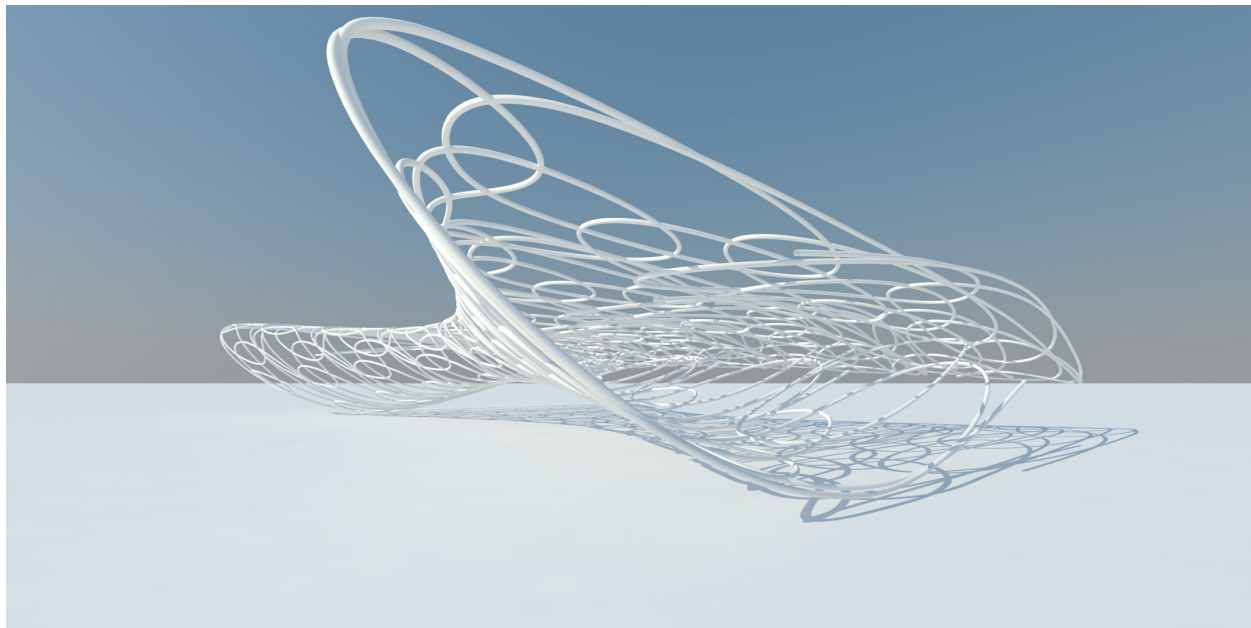

Fig. 14.2.17

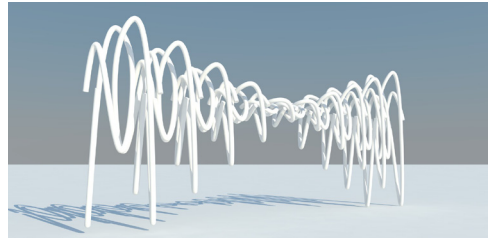

Fig. 14.2.18

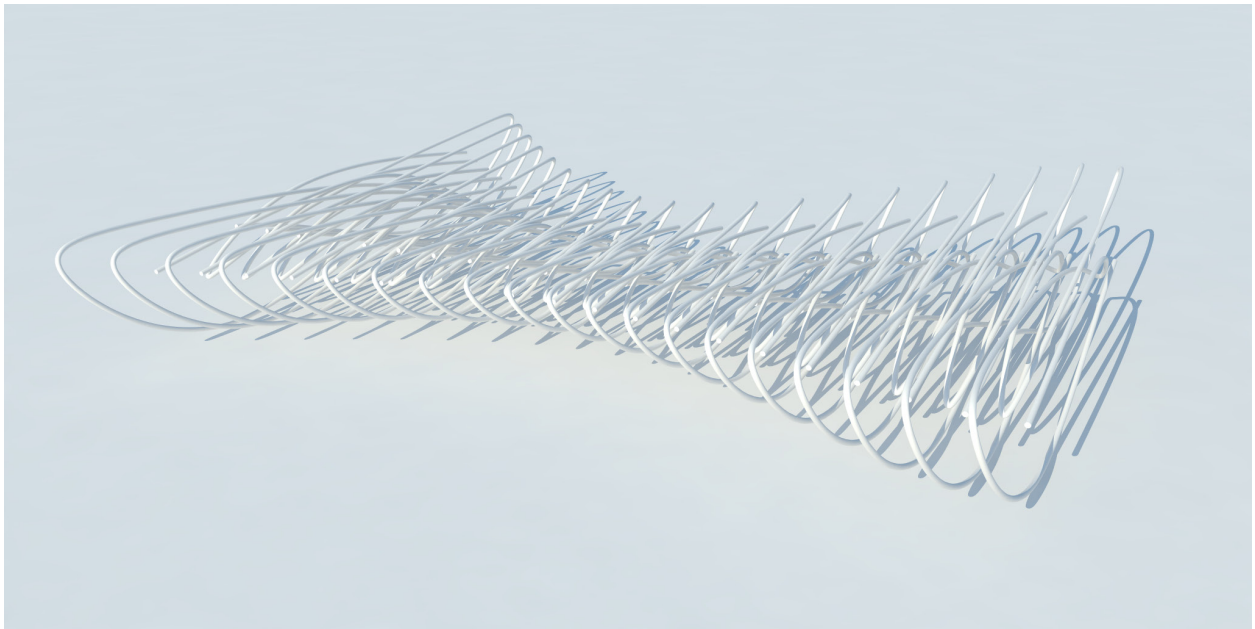

Fig. 14.2.19

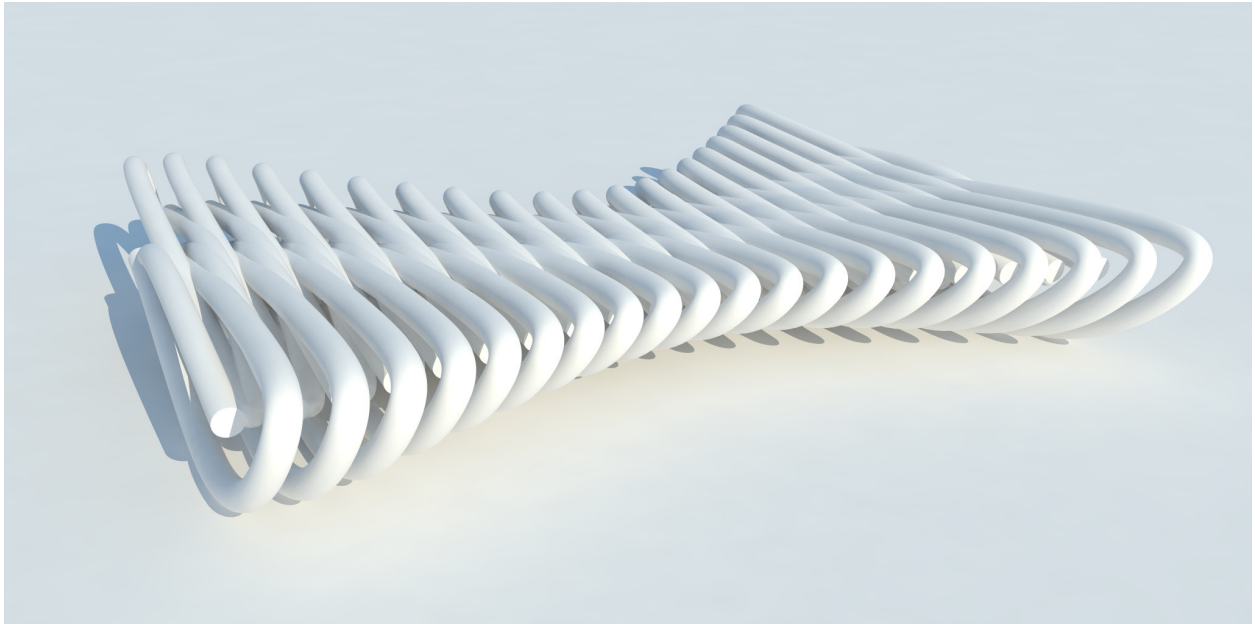

Fig. 14.2.20

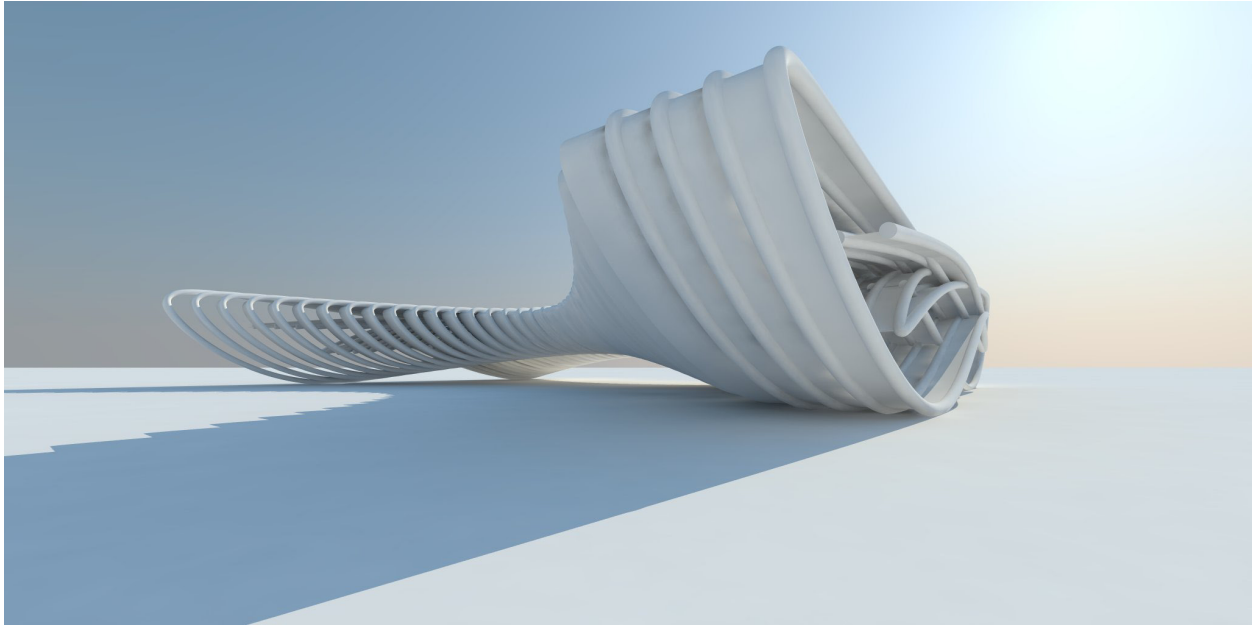
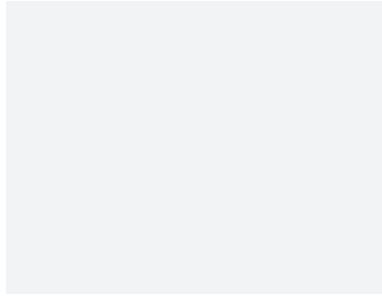

Fig. 14.2.21



Fig. 14.3.1



Fabricating a Digital Stitch

Unlike the analog model, the question of fabrication is heavy on the mind for those working digitally. Rapid manufacturing and CNC machines are utilized in the realization of these digital models. In the physical model, this is a front-loaded question, as you cannot begin a model or analog process of making without material and a method. Digital modeling and prototyping tools are continuously developed in order to provide precise and accurate physical models. The realization of the digital crochet model requires a method of fabrication that can construct the complex corners and tight tolerances. The 3d printer is, at the moment, the best tool to fabricate this structure. In the materialization of the digital crochet, yarn is replaced by the systematic layering of ABS plastic.

The digital model allows for the ability to deform and manipulate the geometry in



Fig. 14.3.2

ways the analog model cannot. There are characteristics that can be changed with great certainty. This includes the ability to change the diameter and cross section of the “thread” to vary the uniformity of each loop based on parameters defined. Additionally, the digital crochet allows for the intersection of the loop geometry due to the inability for a material to occupy the same space simultaneously. This intersection of the geometries happens within the software and can be realized through rapid prototyping technologies. When printed, these intersections (*Fig. 14.3.2*) join to become a single geometry. When comparing the digital print to a material crochet, one must realize that though the digital was created through the diagramming and abstraction of crochet, it is no longer crochet. The digital print and the sisal mat are two distinctly different objects in process, material, and name.



Fig. 14.3.3

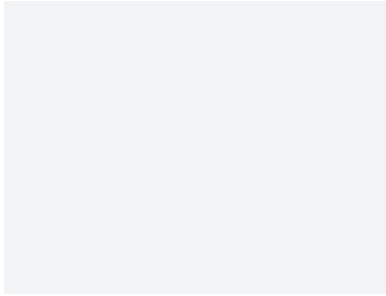

Fig. 15.1.1

Explorations: Wrap and Stretch

In many cases, it is the space between the thread that is the most seductive. Therefore, the following experiments focus on the openings and space between the thread rather than the material itself.

These experiments begin to use crochet for its intended purpose as it pertains to a garment. Crochet is not only a method of making textiles or clothing, it is a specific way of constructing surface, structure, and ornamentation. The beauty of a crochet object comes from wearing it and its ability to stretch over a figure or shape. These explorations look at crochet when it is being wrapped, pulled, and stretched.

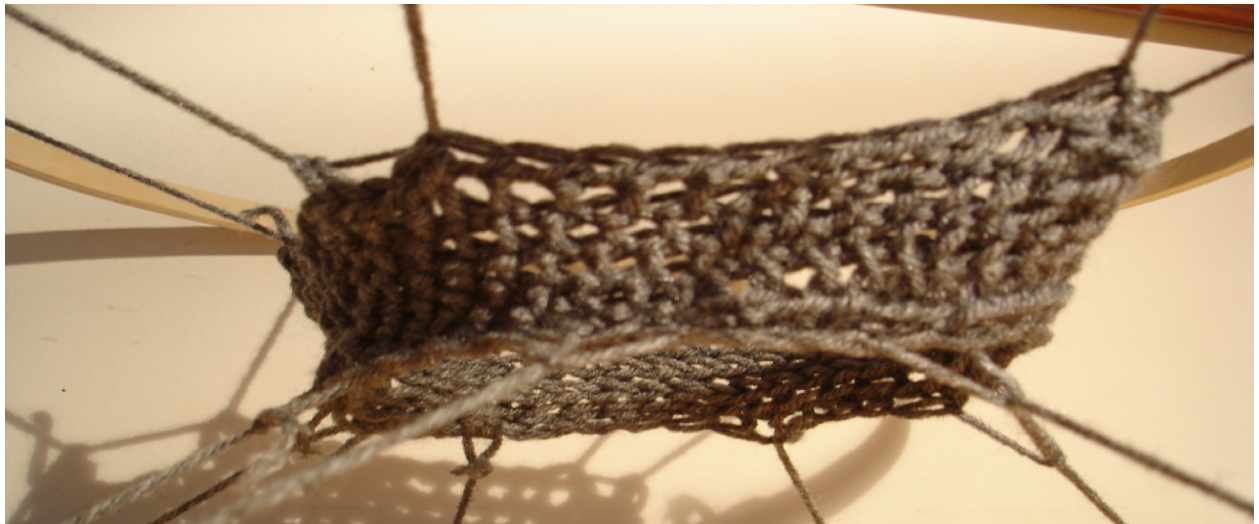

Fig. 15.1.2



Fig. 15.1.3

Wrapping

When wrapped around irregular objects like the human body, the netting of crochet and fishnet beautifully articulate the undulating curvature of the human form. The expansion and contraction of the openings delicately accentuate the change in curves, from chest to torso, biceps to forearm and thigh to calf. Though beautiful on its own, the human figure is sensuously articulated by the crochet. Its ability to expand and contract, hugs the form that it covers. The subtle variation caused by the stretching and pattern captivates the eye.

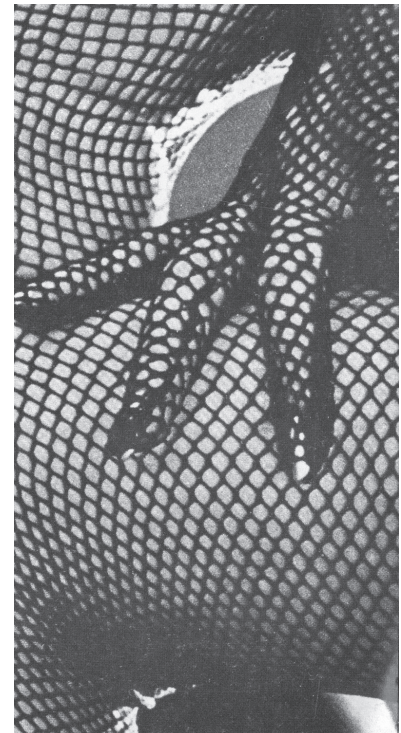

Fig. 15.1.4

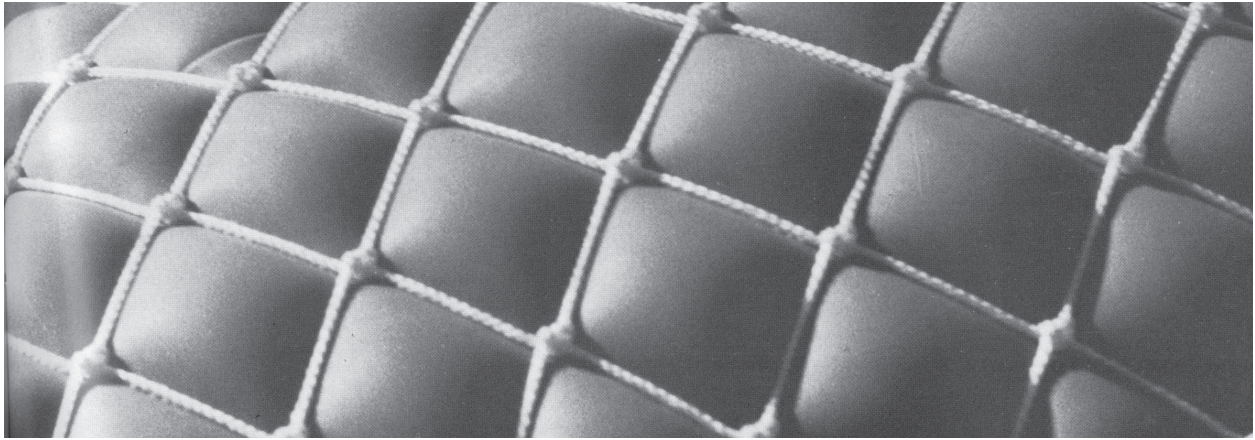

Fig. 15.1.5

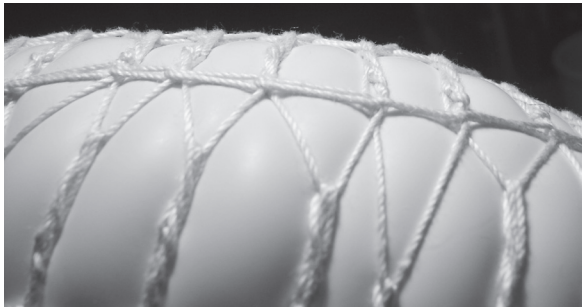

Fig. 15.1.6

In IL 8 - Nets in Nature and Technique, The Institute for Lightweight Structures studied the interaction of netting in different applications: mesh bags, safety nets and nets stretched by the use of inflated membranes or pneumatic structures. The use of inflated membranes, or pneus, give rise to varying effects. When a crochet surface has been wrapped around a pneu and then inflated, the membrane not only stretches the crochet but begins to pop up or bubble up through the openings, resulting in a very different effect. The structure of the crochet remains the same, but it does have a direct effect on the inflated membrane. By wrapping the crochet around a pneu, the experiment exemplifies the opening and no longer the thread itself. (*Fig. 15.1.5 & 6*)



Fig. 15.2.1

Stretching

“One, two or three dimensional pressure resistant structural members can be arranged inside the nets as also found in the skeletal structure of vertebrates... External framework can also be arranged outside the nets” (Otto, 32, IL8)

When pulled, the crochet deforms as the edges pull towards the center of the surface (Fig. 15.2.1). These forms can be found in the IL experiments with tensile membranes. They are surfaces identified by Siegfried Gaß in IL25 as anticlastically curved surfaces. Unlike the minimal surfaces of soap film and fabric membranes, when a mesh or net is pulled, the surface becomes increasingly porous. This ability to stretch is directly related to the type of material and stitch used. Based on the internal configuration and material properties, each stitch will have different properties in stretching and elasticity.

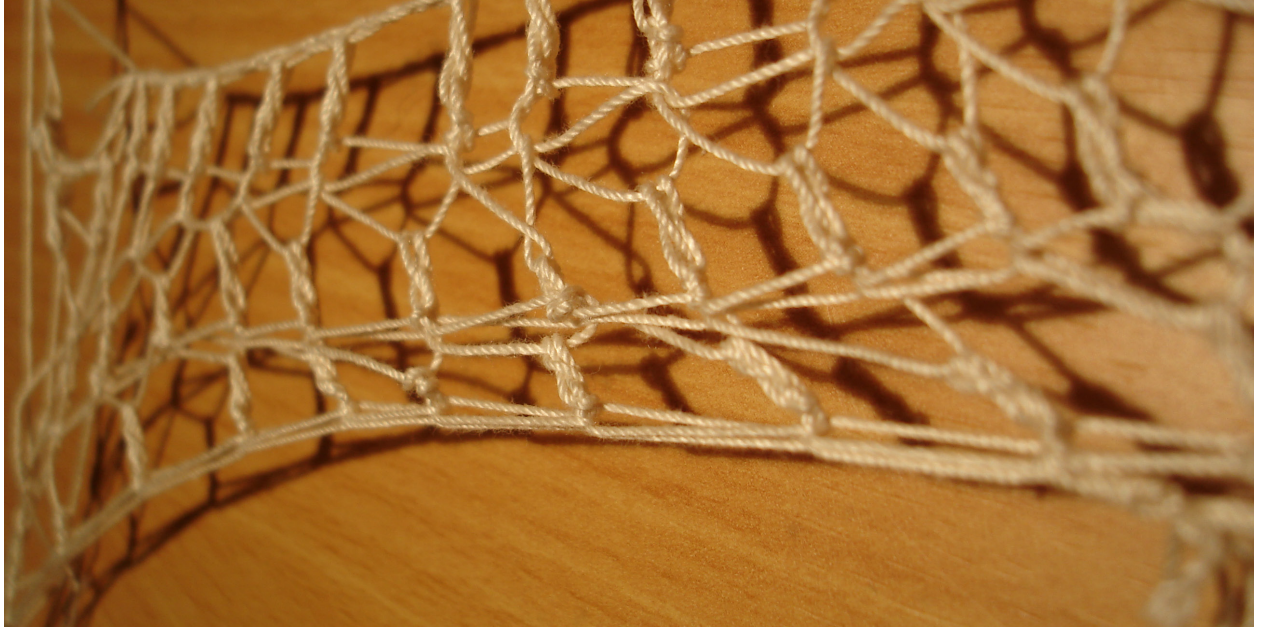
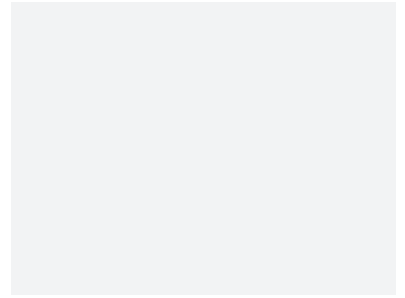
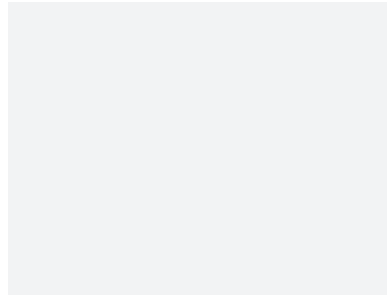

Fig. 15.2.2



Fig. 15.3.1

Overstretching

In continuing to explore the ability crochet has to stretch around most any form, a simple wooden cylinder is used in order to see the maximum elasticity of a wool thread tube using a slip stitch. Once the sleeve is stretched over the cylinder, the sleeve is pulled at both ends. This overstretching pulls the crochet to its maximum dimension. The wooden cylinder becomes visible through the openings defined by the crochet. Though the tube is overstretching in its length and diameter, the length of the tube can also be compressed in discrete sections (*Fig. 15.3.1*). This results in a gradient change in porosity of the openings along the length of the tube. Still overstretching in its diameter, the tube remains affectual; the stitches and thread can renegotiate based on manipulations.

When the tube is overstretching in its diameter and length, the process of its construction is clearly visible. As discovered from the experiment in crocheting a tube without a pattern, a tube is constructed by the use of a single chain that is continually hooked into itself by a slip stitch. The crochet tube's internal structure



Fig. 15.3.2

is a helix. When pulled over the wooden cylinder, the tube is overstretched and must reconfigure to maximize its stretching ability. By doing this, the slip stitch is reconfigured into diagonal restraints connecting each revolution of the optimized structure. This experiment shows how the looped structure of crochet can reconfigure itself into an easily recognizable structure of diagonal restraints between each helical revolution.

This discovery becomes a critical point in using crochet to execute an architectural idea. This helical structure with diagonal bracing, found within a crochet tube, becomes the base for translating crochet from a textile product into a built structure. In translating the structure of the optimized crochet tube, action, process, and method deeply influence the structure. Through a difference in method and execution, this translation exemplifies Semper's statement that "the beginning of building starts with the beginning of textiles."



Fig. 16.1.1

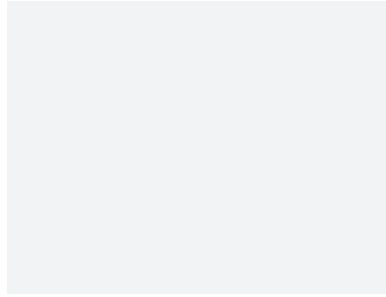

Defining a Crochet Space

The experiment in overstretching results in the emergence of an optimized system translated into structure. The crochet technique as a medium to model and generate structure is verified through its exploration. To continue the refinement of crochet into architecture, one must begin to use the methods and techniques of crochet to construct models that define and test space.

By working with the process of crochet, and within the boundary form of a tube, this approach drastically changes the way an architect must think about defining space. Unlike the traditional method of working in individual planes, the tube requires a holistic approach to defining space. When working with the tube structure, the designer can no longer think of plan, section, and elevation as discrete moments. The process of crochet, and the tube structure, require a constant dialog between bottom-up and top-down.

A holistic design process was of great concern for Frederick Kiesler, the architect of the Endless House. The Endless House was his exploration of employing physical modeling techniques to define space within the typology of a house. Critical of the traditional design process within architecture, Kiesler believed that a space should arise out of a generative approach rather than an imposed order.

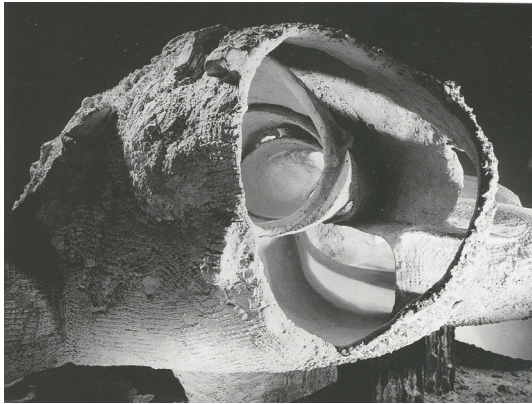

Fig. 16.1.2

*The floor plan is more than the footprint of the house... If God had begun the creation of man with a footprint, a monster (of) all heels and toes would probably have grown up from it, not a man. He might have been without head and arms, to say nothing of his internal structure. (Kiesler, 29, *The Endless House*)*

In *The Architecture of Continuity*, Lars Spuybroek reiterates Kiesler's concerns that traditionally-trained architects first draw the plan, simply project it upwards, extruding it into the elevation; treating walls, floors, and columns as distinct elements. He calls for the architectural design process to parallel the growth development of the human body and to consider architecture as plastic, topological, and continuous. This can be achieved in crochet by using it as a medium to generate form. It embodies a generative approach where one can work freely towards a design or unknown result.

Kiesler expressed the desire to work freely by working in physical models. By working with a variety of materials, this enabled him to define form that was

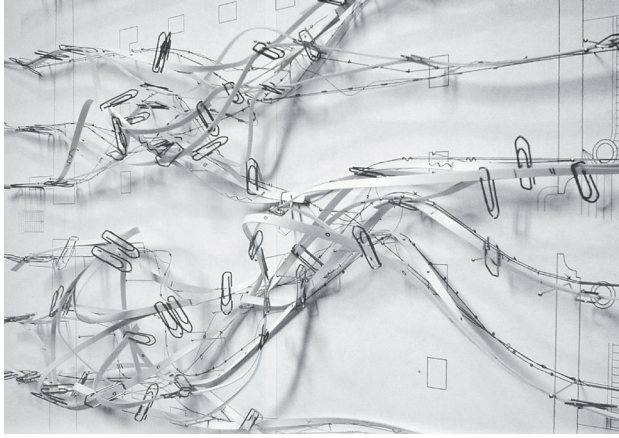

Fig. 16.1.3

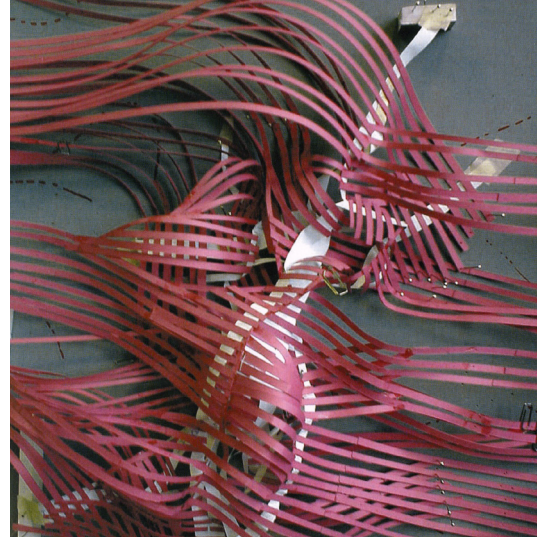

Fig. 16.1.4

conducive to working holistically. Similarly, Lars Spuybroek utilizes the physical laws in analog computing by harnessing material properties. He does this by using threads, paper strips, rubber tubes, and liquid agents as a medium to generate form. (Fig. 16.1.3)

“The bottom-up view, the lines are suddenly not flat ink anymore; they have taken on material properties. This is no longer molding the clay from the outside by drawing; this is building a machine of variability.. So I don’t draw. I’m not up there in the air dropping black lines onto the world.”
(Spuybroek, 104, *The Architecture of Continuity*)

Crochet perfectly embodies this generative approach to design. When crocheting a tubular form, the designer never works directly in plan, the entire enclosure must be realized simultaneously. This can be affected by decisions made during the crochet process. Each loop is an opportunity for critical judgment and discrete modification. These decisions of the designer affect the overall form. By employing techniques found in crocheting, this generative process is used to adjust the structure of the tube and results in spatial variation.



Fig. 16.1.5



Fig. 16.1.6

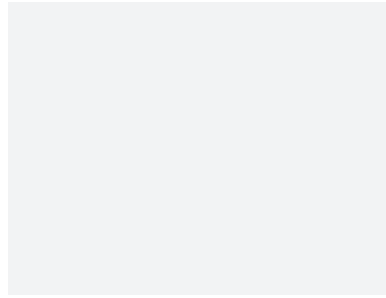
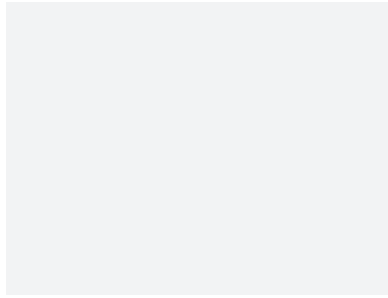

Fig. 17.1.1

“Generative techniques use algorithms written (into computer code) to determine the state of a system at an incremental point in the future. As the algorithm is repeated iteratively the system evolves over time.”
(Rahim, 02-025, Catalytic Formations)

Generative Techniques

Crochet is a generative process. This is proven by looking at the algorithm used to crochet a hyperbolic plane. However, the pattern or algorithm can be modified at any time. These generative techniques can dramatically change the qualities of both the structure of the crochet and the space it defines.



Fig. 17.1.2

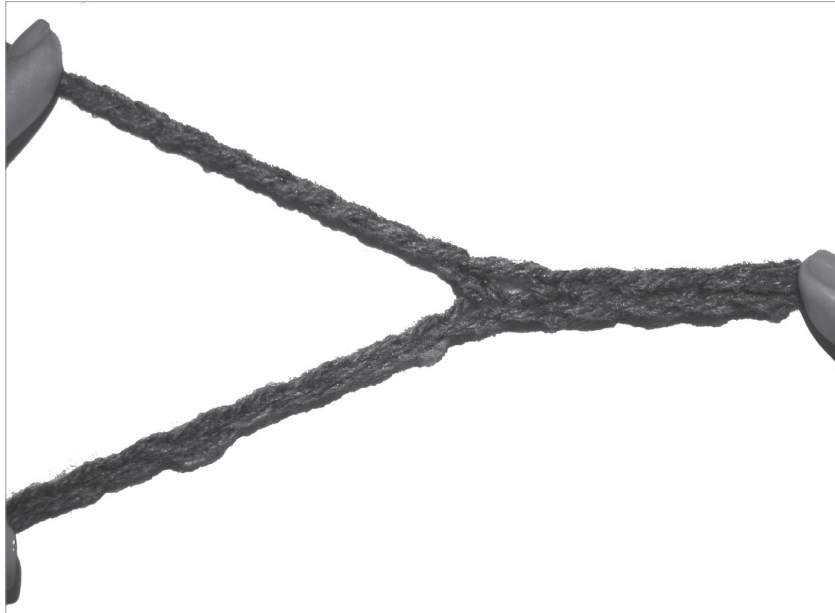

Fig. 17.2.1

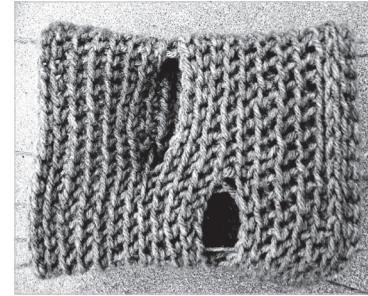

Fig. 17.2.2

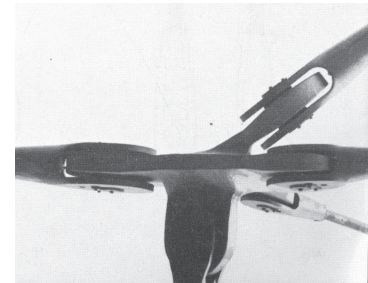

Fig. 17.2.3

Branching Chains

Branching is a technique where the crochet chain does not hook back into the crochet piece. The new chain then can either hook back into the previous row or branch off. If the new chain is hooked back into the previous row, then an opening is created in the crochet surface. If the chain remains free then it begins a new base chain that has branched from the previous surface.



Fig. 17.3.1

Stuttering Loops

Stuttering is the exponential addition of loops into a previous loop. This is the technique that gives rise to the hyperbolic planes of Daina Taimina and is written as, `crochet N loops, increase X loop(s)`. The benefit of such a technique is that the surface area can increase exponentially in the area the stuttering has occurred. Stuttering can drastically affect the final form of crochet figures.

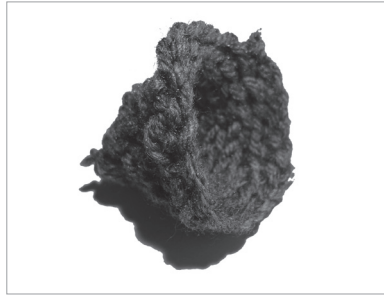

Fig. 17.4.1



Fig. 17.4.2

Skipping Loops

Skipping is directly opposite of stuttering where chains are not added but rather skipped when hooking back into the chain. Crochet N loops, skip X loops. Skipping can be found in crocheting a triangle and a cone; each subsequent row has one less loop than the previous row.

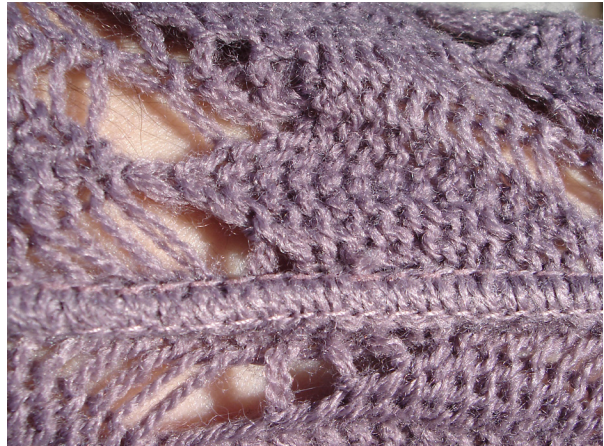

Fig. 17.4.3

Generative techniques are not the only techniques that can be used in crochet though they are very powerful tools in creating openings, apertures and dividing space. Generative techniques can be used in combination with one another along with different crochet stitches.

In order to define an architectural space with crochet, it may be necessary to borrow other techniques in textiles and garment making. The ability to manipulate, stitch, pleat, fold and deform the crochet is necessary in the definition of space with crochet.

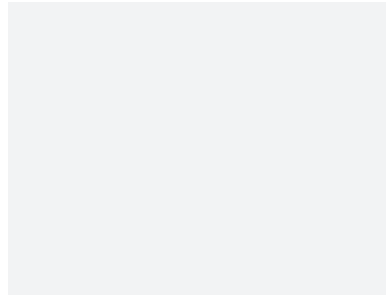
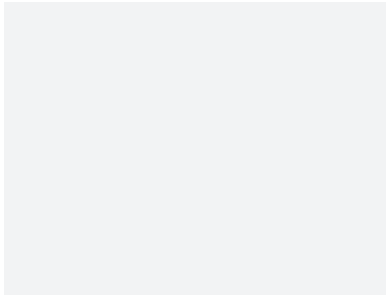

Fig. 18.1.1

“To manipulate (a) continuous surface - object structure in such a way that manipulating any point onto the surface cause all other points to be redistributed. Applying transformational operations such as folding, stretching...and pressuring to these continuous surfaces results in change to the whole.” (Rahim, 02-025, Catalytic Formations)

Transformational Techniques

Similar to the experiments in stretching and forming, transformational techniques enable direct manipulation of the crochet surface. Unlike the generative techniques, transformational techniques are top-down, the change is willed into the crochet by the designer.



Fig. 18.2.2

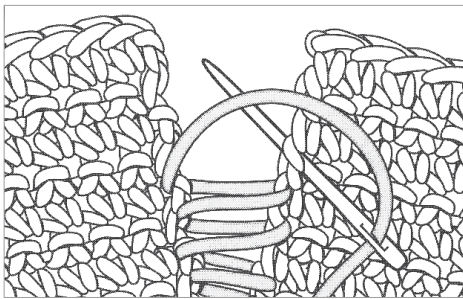

Fig. 18.2.1

Stitching

Stitching can be identified by a seam on a garment. In many cases, the seam is expressed or highlighted. In crochet, stitching can easily blend in and is normally subtle and not called out. Stitching enables the ability to connect multiple pieces of crochet to one another.



Fig. 18.3.1

Pleating

Pleating can be used in order to tighten an area or divide a surface. Pinching leaves a dart that can be folded over. In order to hold the pleated material, a thread is needed to stitch between the two surfaces. Pleating can be used to divide a surface into pockets.



Fig. 18.4.1

Stretching

Stretching a crochet surface changes the entire form of the crochet. The elasticity of crochet is based on the material, stitch type, and the tension built into each loop. Though stretching is still a transformational technique, the overall effect in stretching is influenced by the tension designed into each stitch.

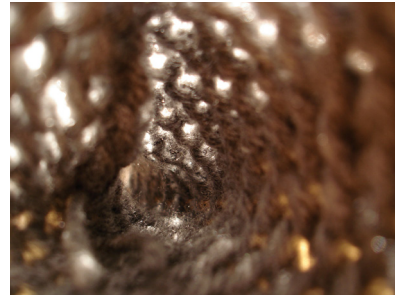
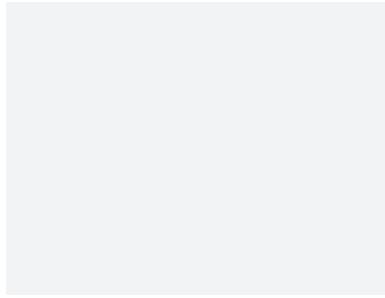
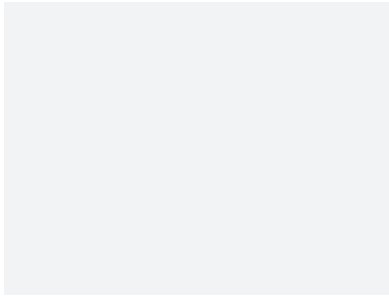

Fig. 18.4.2

By using these techniques, the designer gains a flexibility and freedom to create and define any configuration of spaces. In the continuing efforts to define a form and space through crochet, one must work to a goal. Crochet cannot define external requirements of a space, it needs to be defined by the designer. Each space holds specific qualities that define it; the definition does not come from a catalog of functions but rather from the qualities within it.



Fig. 18.4.3



Fig. 18.4.4



Fig. 19.1.1

Qualities of a Crochet Space

“Mainly analog models...are employed for the investigation of self-forming processes and the experiments carried out for their use in architecture which shows the form of a structure as the state of equilibrium of the forces acting in it or transferred by it.” (Gaß, 1.5, IL25)

In order to develop and define space with crochet, desired qualities must be determined or discovered by the designer through exploration and play. The definition of particular qualities begin to aid in the development of space. In *The Endless House*, Kiesler was interested in essence rather than program. By working this way, he was able to explore his theory by using the qualitative elements that

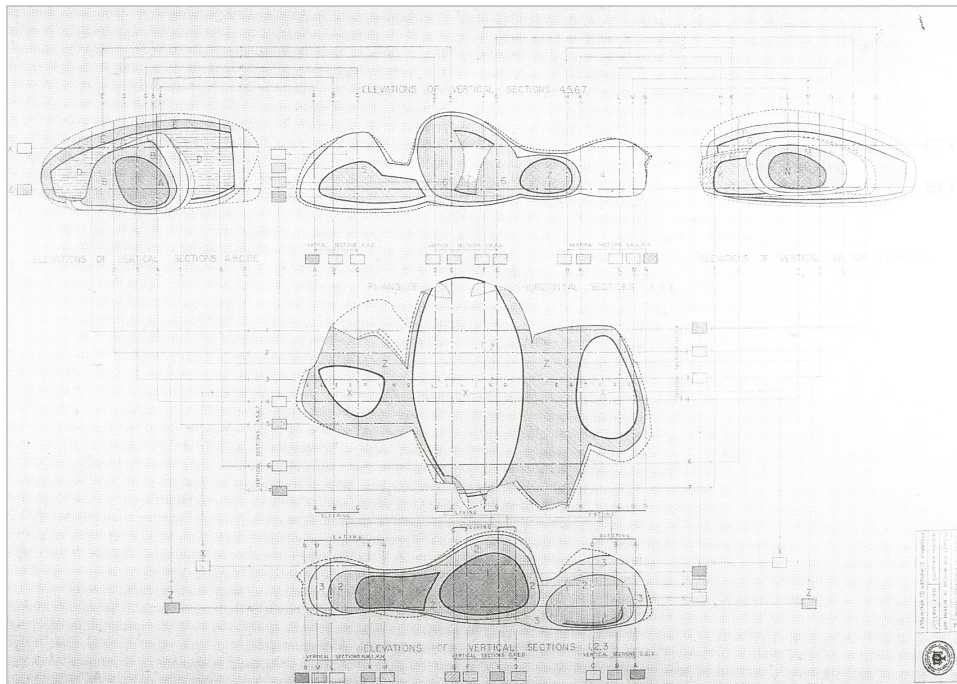

Fig. 19.1.2

defined a home. This qualitative program was necessary in order for Kiesler to proceed in successfully defining space and structure. He was not concerned with the quantitative program but rather he became intrigued in articulating the spirit of the home.

A qualitative program enables the definition of spaces and requirements of the architecture without purely defining its typology. The typology of a structure is arbitrary - defined by the client. The typological distinction is not important in a qualitative exploration. It is the quality of space that can further the exploration.



Fig. 19.2.1

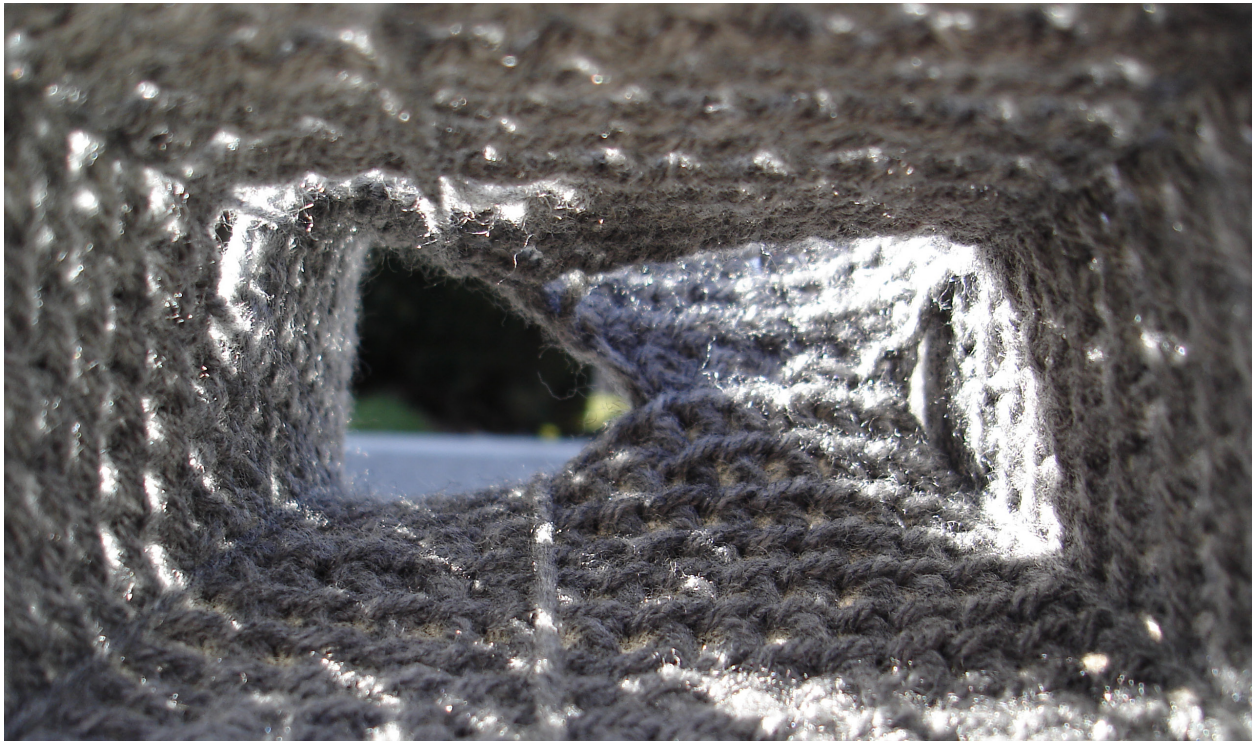
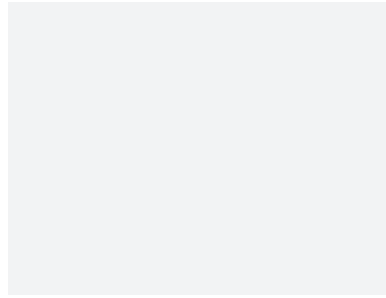



Fig. 19.2.2

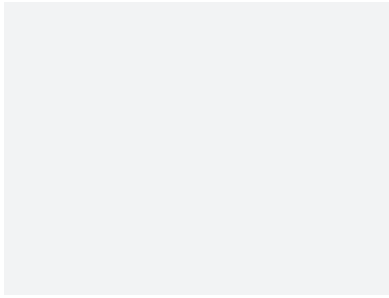

Fig. 19.3.1





Fig. 19.3.2

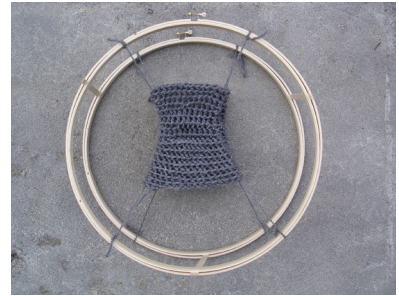
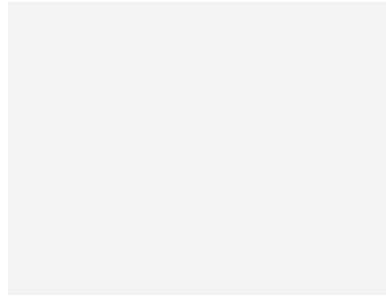

Fig. 19.4.1



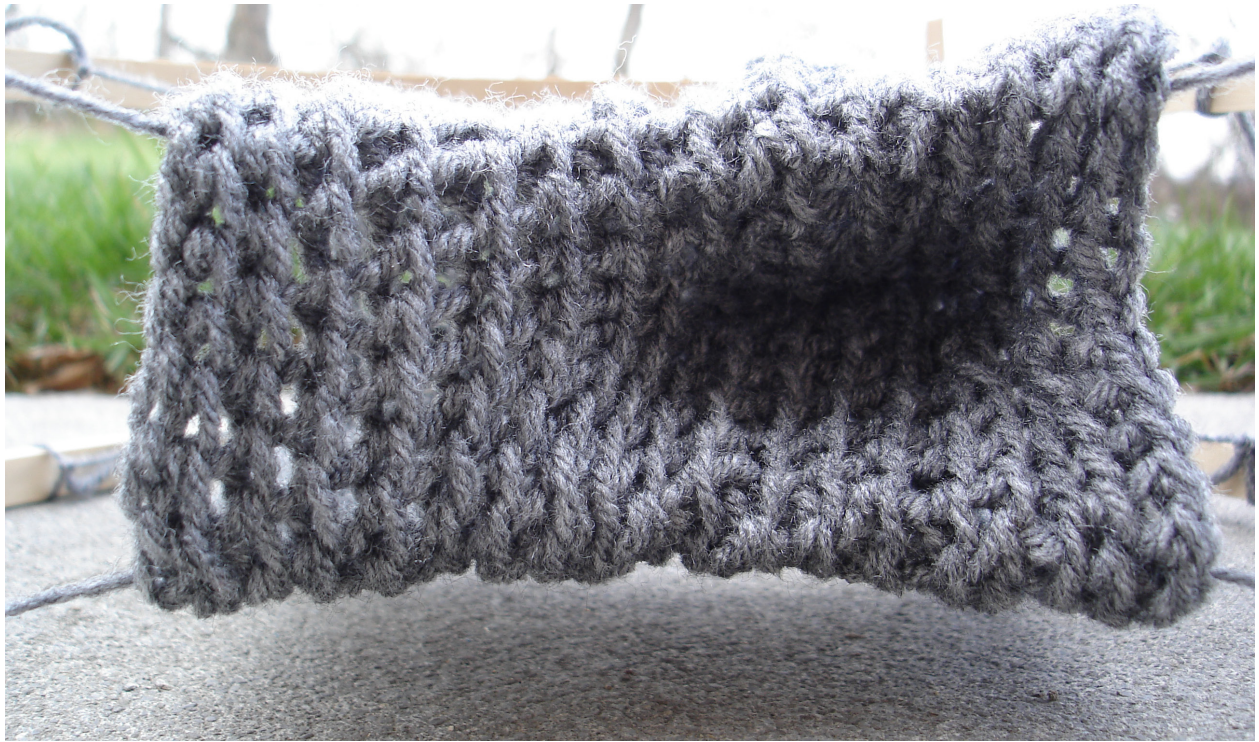

Fig. 19.4.2



Fig. 19.4.3

In order to achieve certain qualities of space, both generative and transformational techniques are used. With these analog machines, one can quickly test the variation of form and space in the physical crochet model. Each model becomes an analog computer where one force begins to affect the whole. Though the analog machine is an optimized tool in defining and visualizing an architectural space, the question of scale and construction come into play. The digital becomes a realm for exploration; the computer aids in the process of visualization, fabrication and testing.

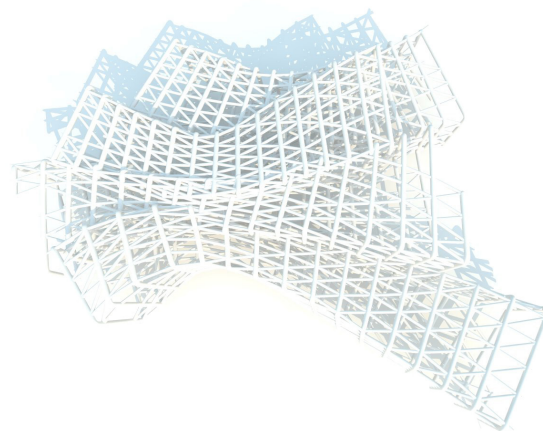

Fig. 19.4.4

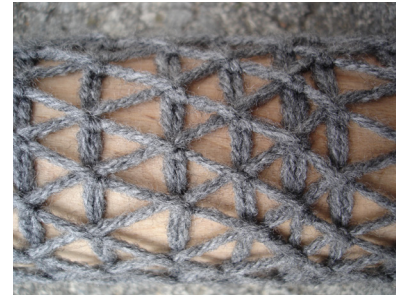
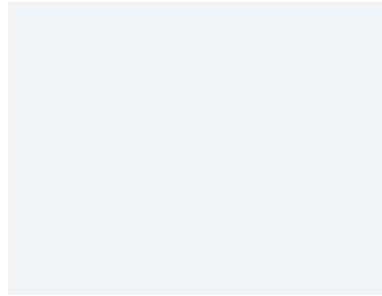

Fig. 20.1.1

The Digital Crochet Space

In the first digital explorations, the translation of an analog crochet into digital space lead to a virtual replica of the crochet loop. The analog thread loop had been abstracted into a static geometry. This digital spline was no longer topological, it became a hardened geometry. The digital becomes a way to visualize, manipulate and fabricate this geometry through the use of digital tools and rapid prototyping machines. The digital exploration did not result in an exploration of technique, but rather became a tool for visualization and fabrication.

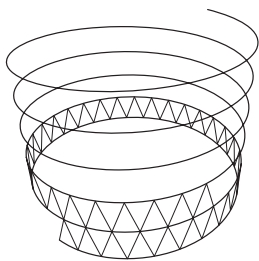

Fig. 20.1.2

After the experiment of overstretching, the digital is used to translate the crochet tube configuration into a structure. The internal structure of the tube is optimized into a helix with triangulated restraints between each revolution. The digital enables the optimized structure to be reconstructed and realized at an architectural scale both efficiently and with a great deal of precision. Just as the experiment in hardening, the translated geometries from the analog must be rebuilt digitally. Software programs which use digital splines and NURBS modeling, like Rhinoceros 3D, have become the required tools to rebuild the complex structure.

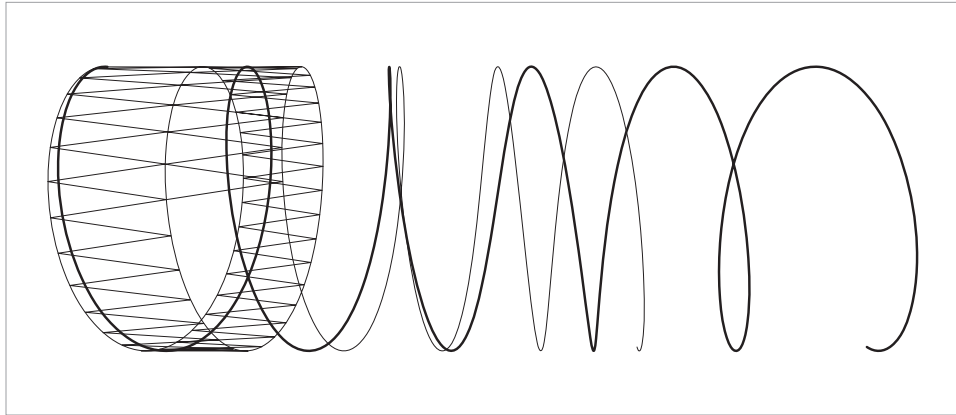

Fig. 20.1.3

As in the first digital model, the drafting of a digital spline remained static and independent. One can begin to craft a helix in Rhinoceros. Once the helical spline has been defined, the diagonal restraints discretely connect each revolution of the helix, resulting in a digital geometry. In the translation into the digital, the diagonal restraints no longer hold the helix together therefore, they brace the helix. By drafting the bracing lines independently, any manipulation done to the helix will not affect the bracing. However, if the helix and bracing are constructed by a set of rules and not by the drafting of lines, then the helix and its bracing can become a holistic system, similar to the analog model. This is achieved by the introduction of Grasshopper. Specifically designed for the Rhino software, Grasshopper allows the designer to set rules, parameters, and relationships between discrete elements. By using Grasshopper, the geometries are not longer static, individual elements, but rather a system. Unlike Rhino, the definition of a helix is no longer based in the static dimension of radii and length, but rather constructed through the use of its mathematical formula.

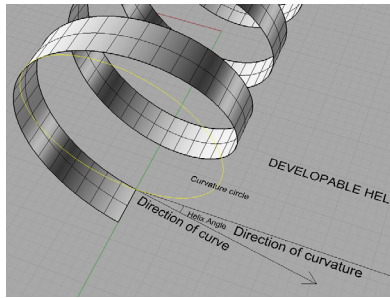

Fig. 20.2.1

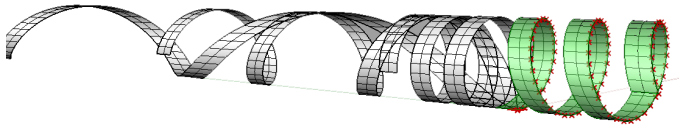

Fig. 20.2.2

Mathematical Formula - Helix

$$x = aa \cos(t)$$

$$y = cc (t - tmin) + 0.4 tmin$$

$$z = bb \sin(t) \text{ (with } aa = bb \text{ for a true helix)}$$

The Parametric Helix

By using the mathematical formula for a helix, Grasshopper calculates and constructs the helical curve. By using this formula, one can vary the number of points along the helix, the degree angle of the helix, and the diameter. These variations occur instantaneously by changing the integers within the formula.

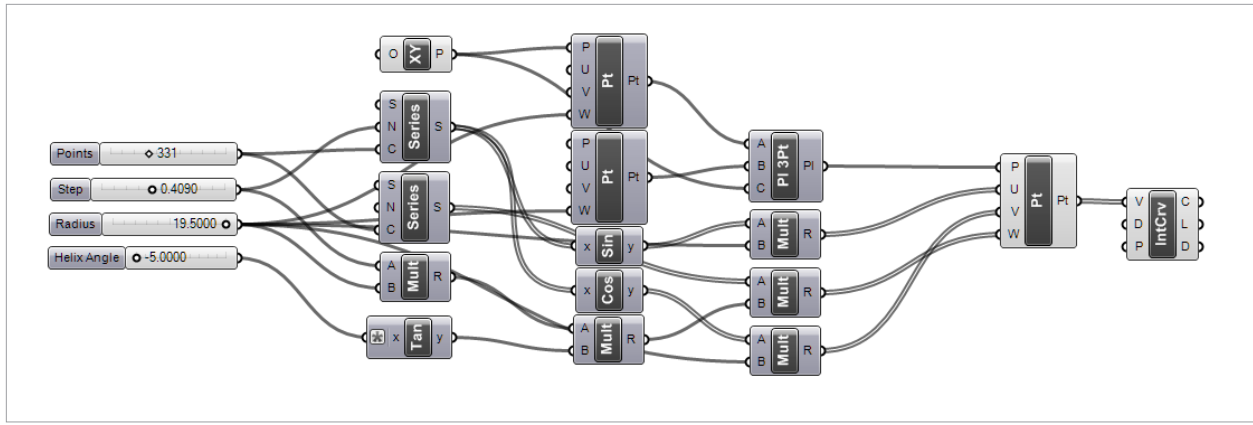

Fig. 20.2.3

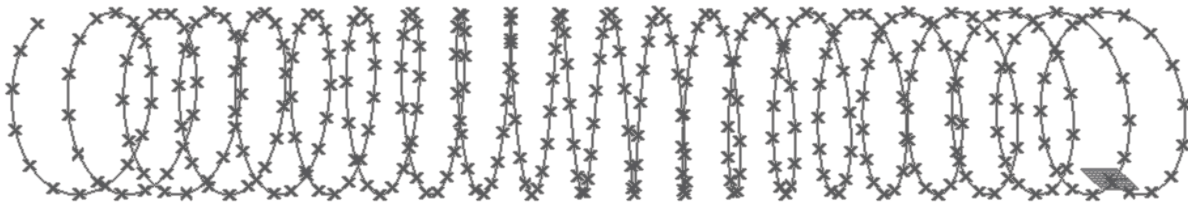

Fig. 20.2.4

Grasshopper 3d works within the Rhino software; the lines and surfaces defined within Grasshopper are not geometric elements in Rhino. In translating the Grasshopper definition into a geometry, it requires a hardening or solidification. This is achieved through baking. Baking solidifies the grasshopper definition, translating it from a set of rules, relationships, and formulas into a geometry within Rhino. The parameters within a parametric helical curve can be changed, but once baked, the helical formula cannot be altered and is hardened into a discrete curve.

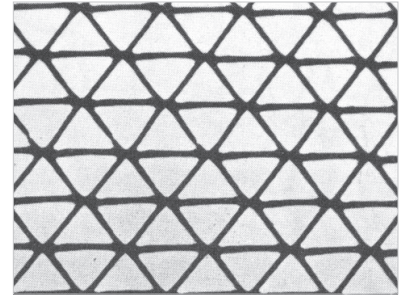
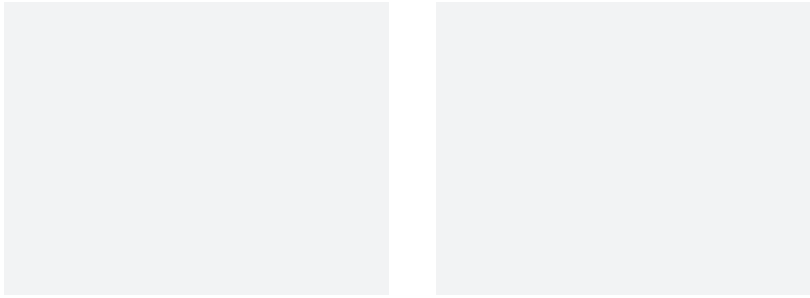

Fig. 20.3.1

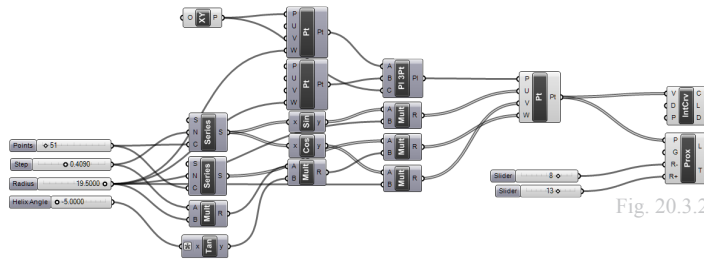

Fig. 20.3.2

Parametric Bracing

Once the helix has been defined within Grasshopper, the next step in reconstructing the analog tube structure is to connect each revolution of the helix with triangular bracing. This can be done manually by drafting the bracing between each helical revolution. However, if the helix is altered in any way, the bracing will have to be rebuilt. To eliminate the redundancy of reconstruction, the bracing is defined by a set of relationships within Grasshopper.

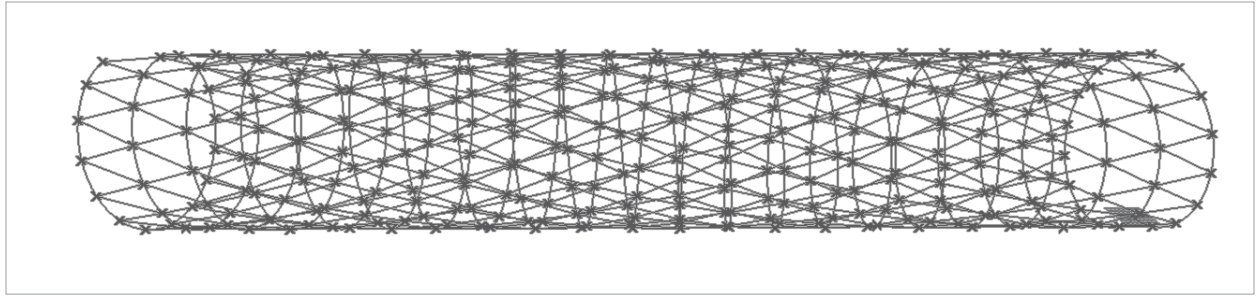

Fig. 20.3.3

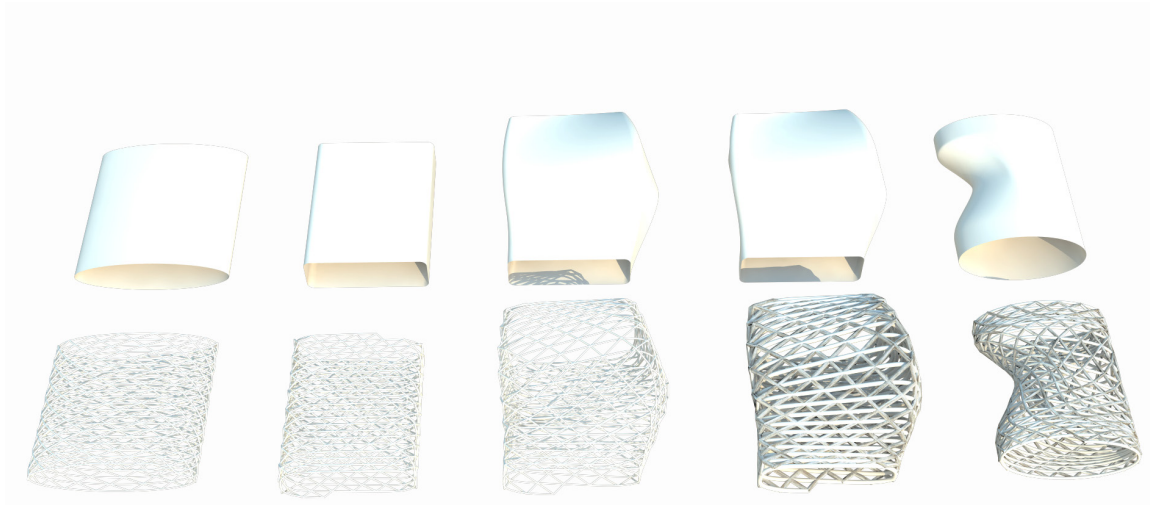

Fig. 20.3.4

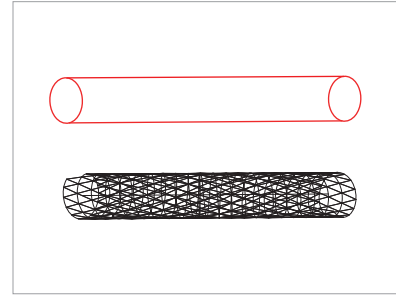
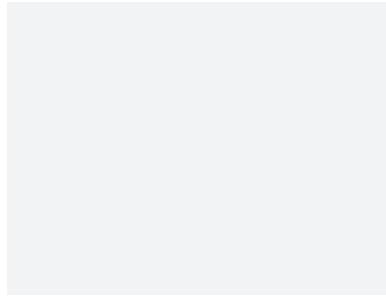

Fig. 20.4.1

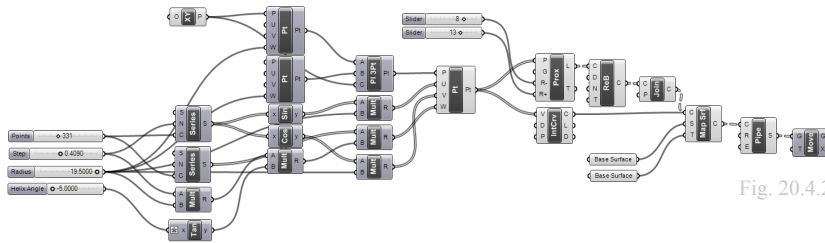
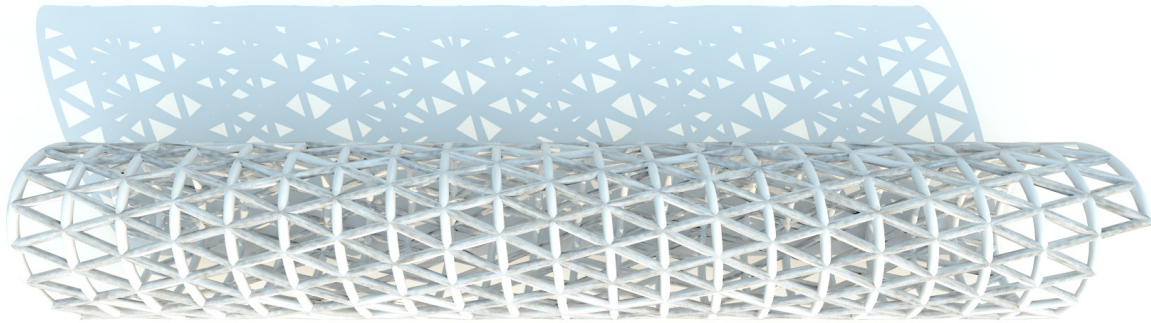

Fig. 20.4.2

Mapping the Curves

Grasshopper enables the mapping of the helix and bracing to a target surface. This allows for the manipulation of the target surface, which results in the corresponding deformation of the helically braced structure. The map to surface component takes the relationship of the base curve to the base surface and applies it to the mapped surface. The result is a curve that is modified based on the mapped surface. Any alterations to the mapped surface directly affects the resulting curve. This eliminates the reconstruction of the bracing when the helical curve is altered.



Base Surface

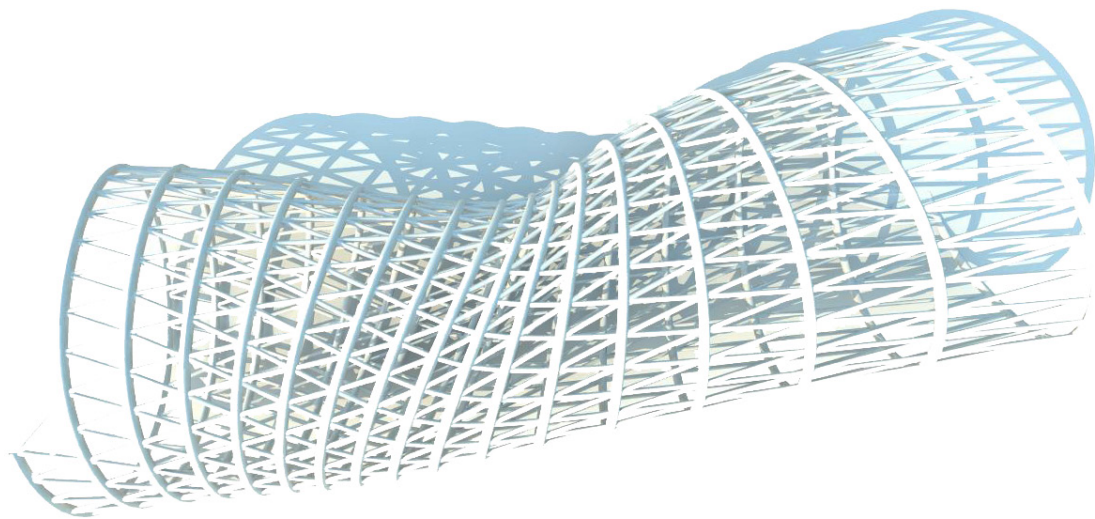

Mapped Surface

Fig. 20.4.3

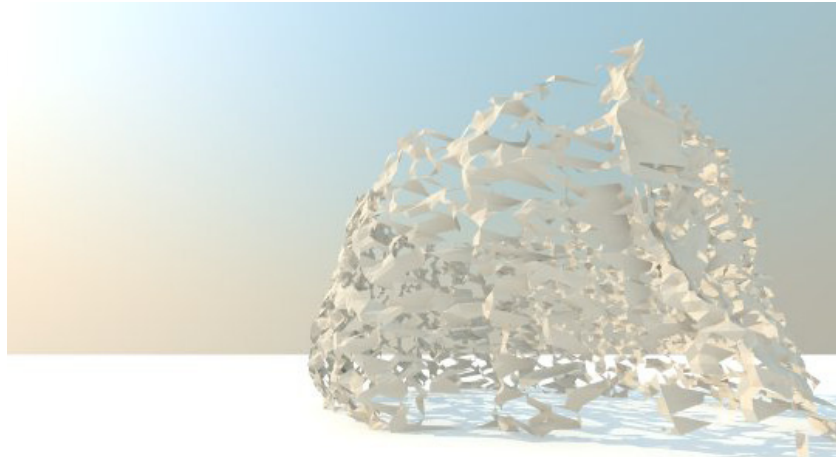

Fig. 21.1.1

Translating Analog to Digital

In the development of digital technology, computer aided drafting, modeling, and manufacturing, there have also been developments in translating an analog physical model into digital space. There are many different techniques to accomplish the digitization of a physical model, some as simple as taking multiple photographs of a model to complex methods such as laser scanners and point digitizers. Laser scanners are used by many industrial designers for small concept objects normally made of foam. The laser can digitize solid, non-transparent objects with great accuracy. However, most of these 3d scanners do not understand a rough, textured, or nappy surface like textiles. Where the scanner fails in capturing data, it leaves a fractured surface, or blow outs, in the digitized model. (*Fig. 21.1.1*)

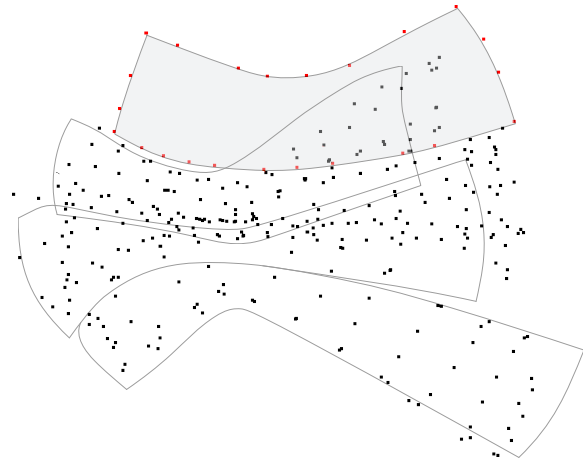
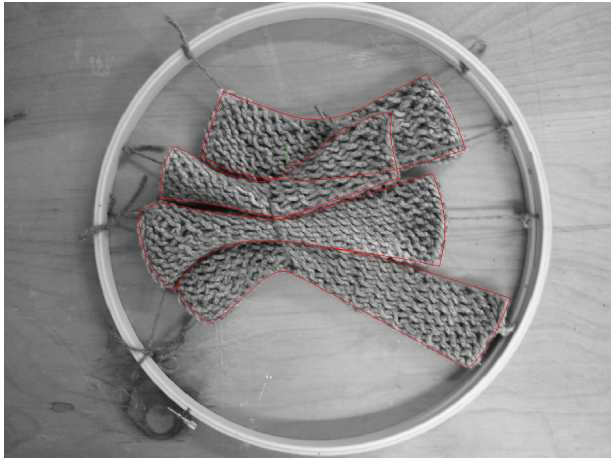

Fig. 21.1.2

In the translation of the analog crochet models into digital space, both photography and the point digitizer are used. Though the texture and pattern of the crochet will not be translated, it is the overall form that is digitally captured and reconstructed. The digitizer is used to capture the crucial points that are used to rebuild the model digitally. The process of digitizing will be determined by each model, some may require more points to be plotted due to their complexity.

The designer must use judgment and manually manipulate the digital points, curves, and surfaces. As with drawing or sketching a building, this process requires a great deal of back and forth, observing both the analog and digital models. This can only be achieved by using one's eye to reconstruct the model.

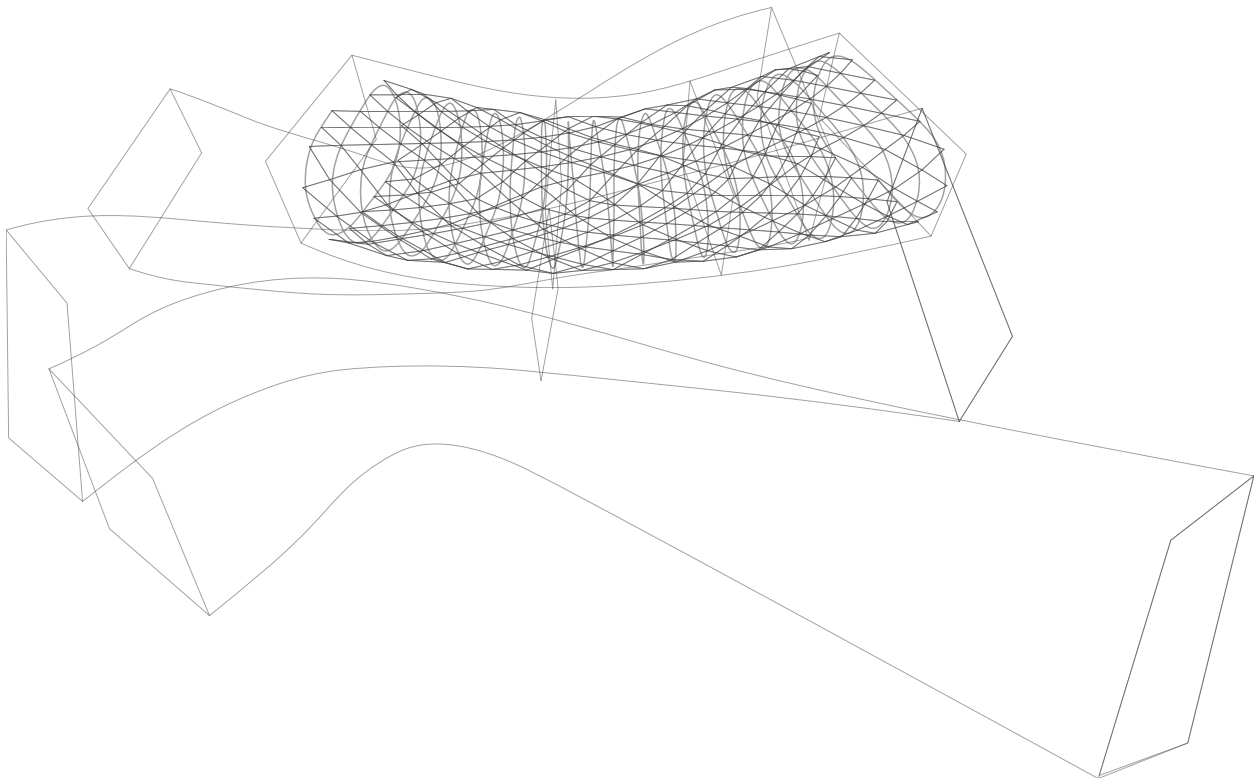
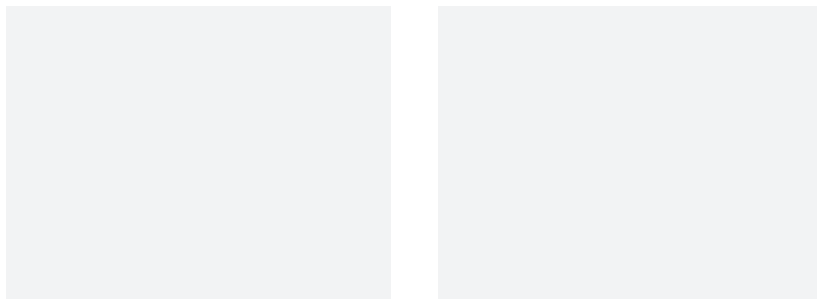

Fig. 21.1.3

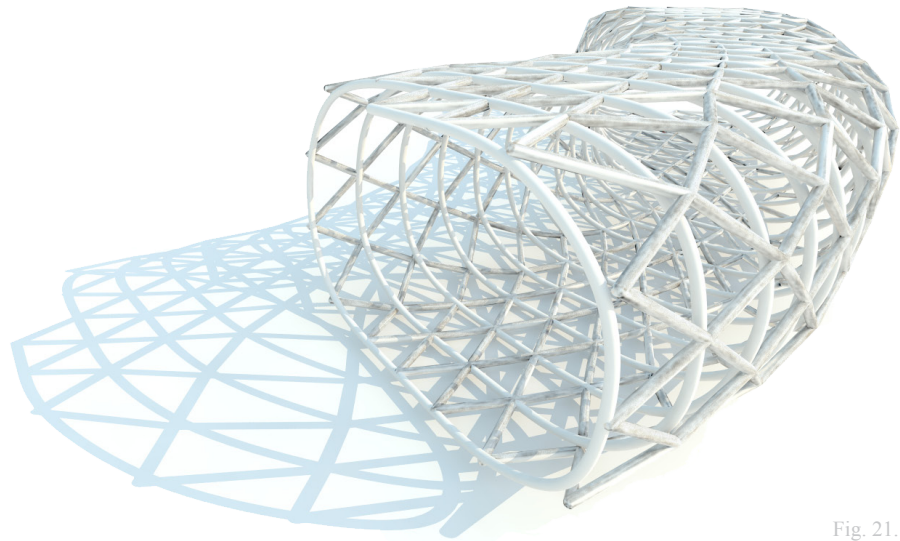
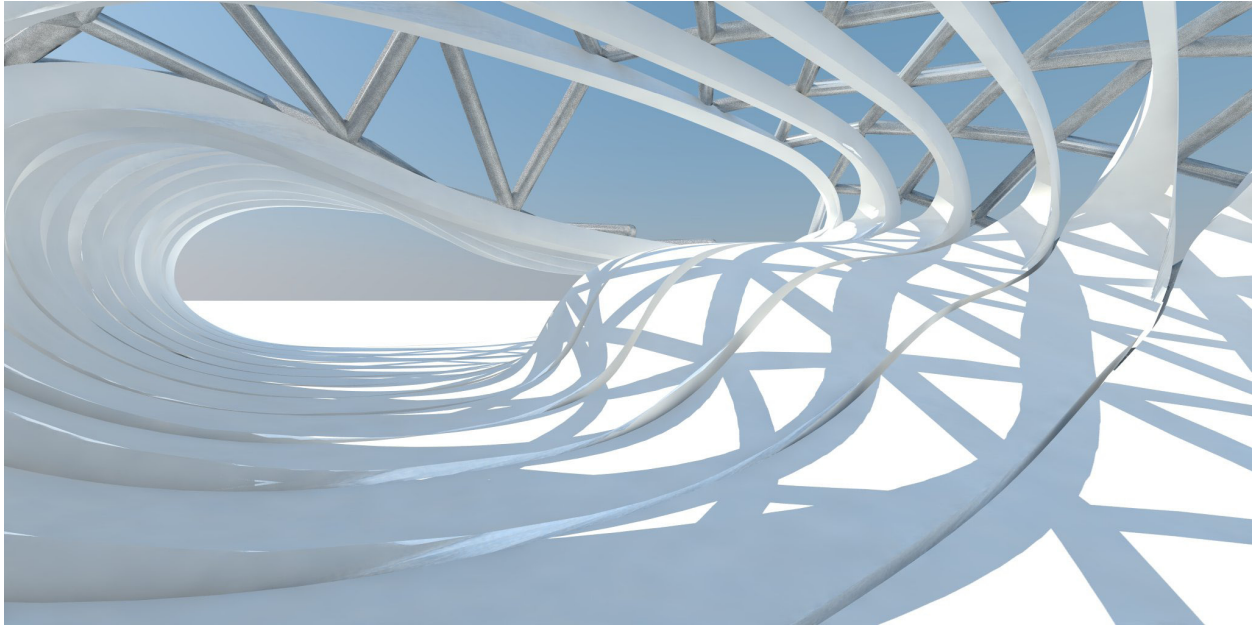

Fig. 21.1.4

The successful completion and translation of the analog to digital model results in a digital surface. Though only the form of the crochet model is translated, the articulation occurs when the Grasshopper definition is applied to the digital surface. This digital model becomes a way to fully explore the design by refining and executing the concept.



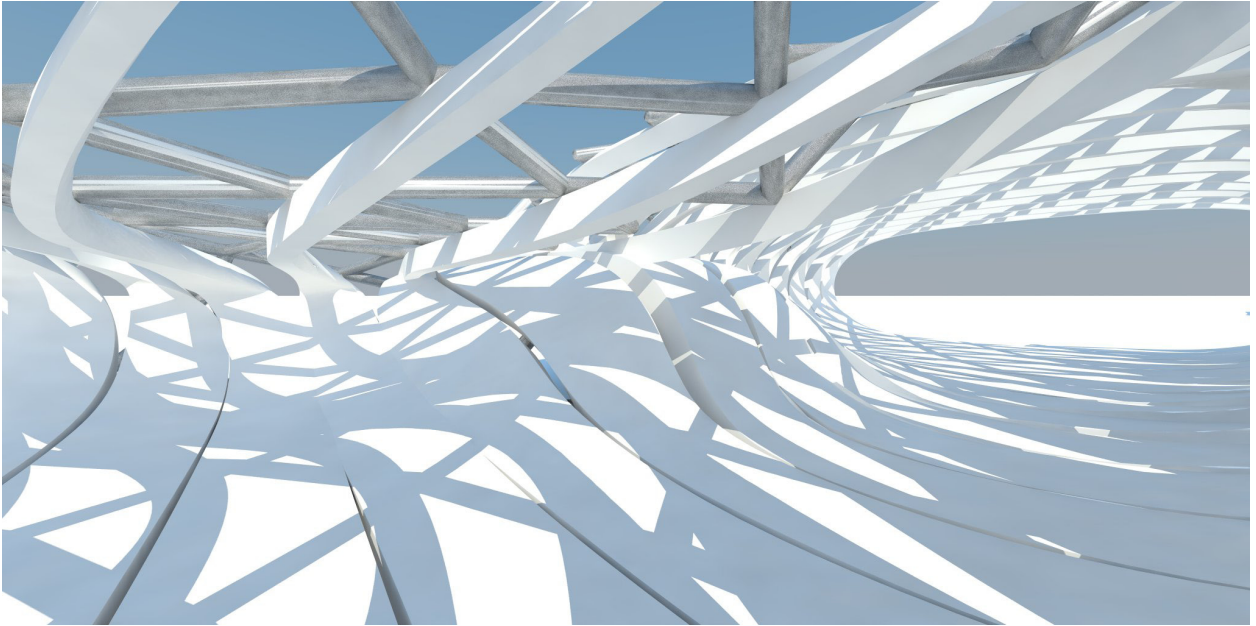
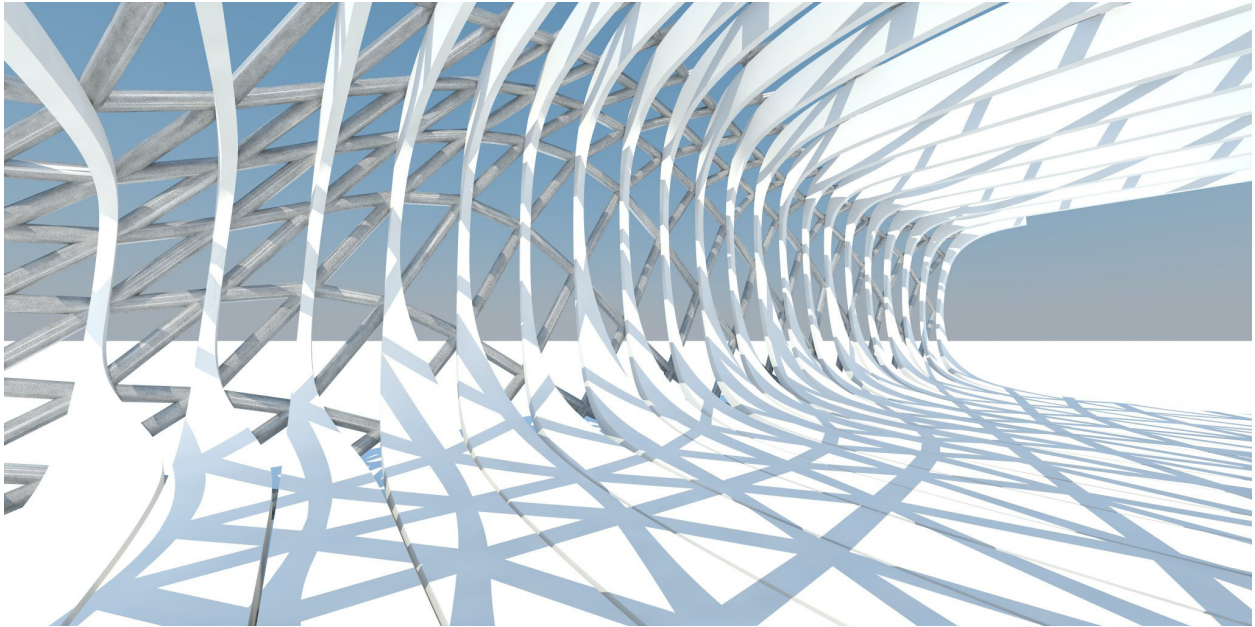

Fig. 21.1.5



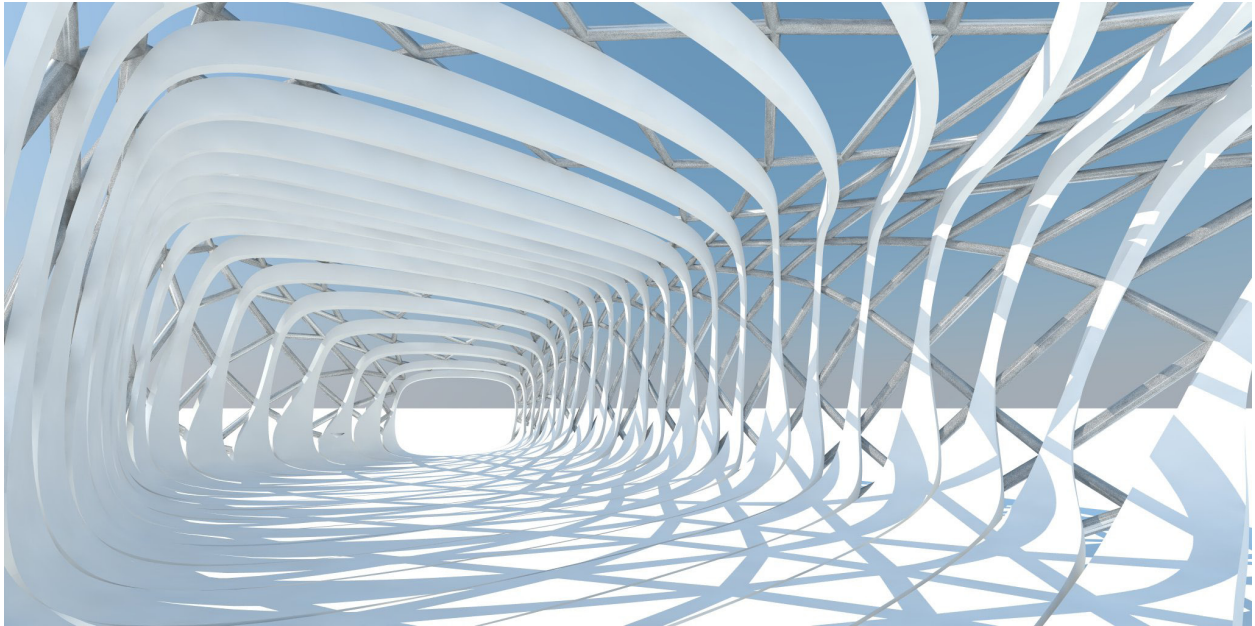
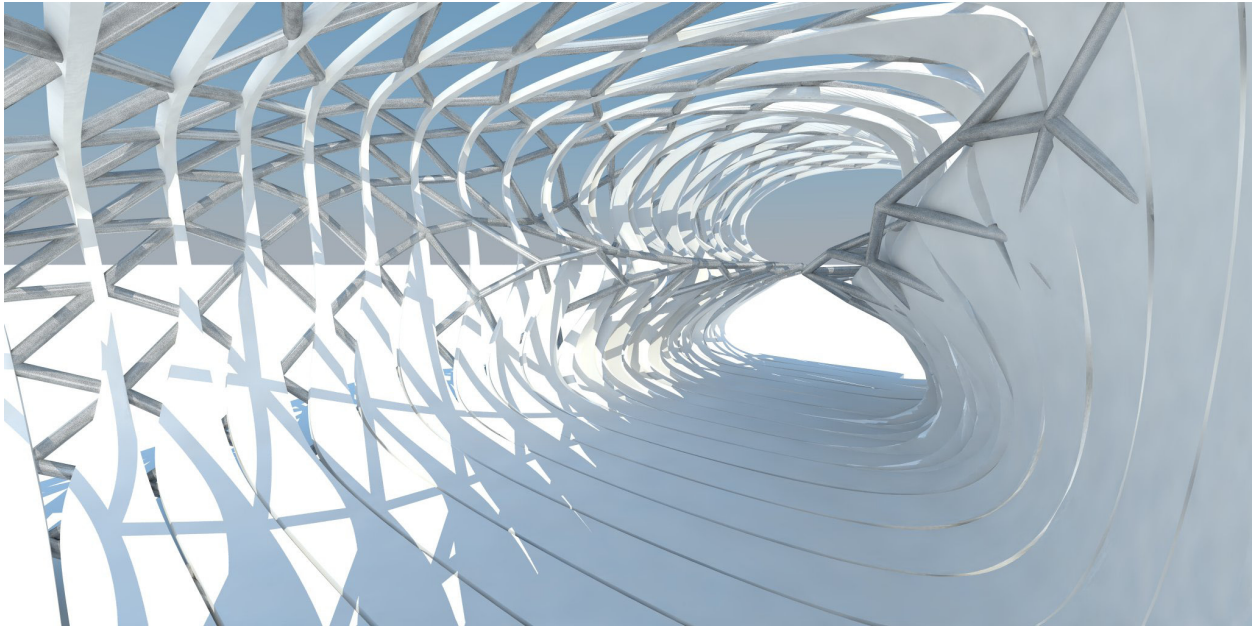

Fig. 21.1.6



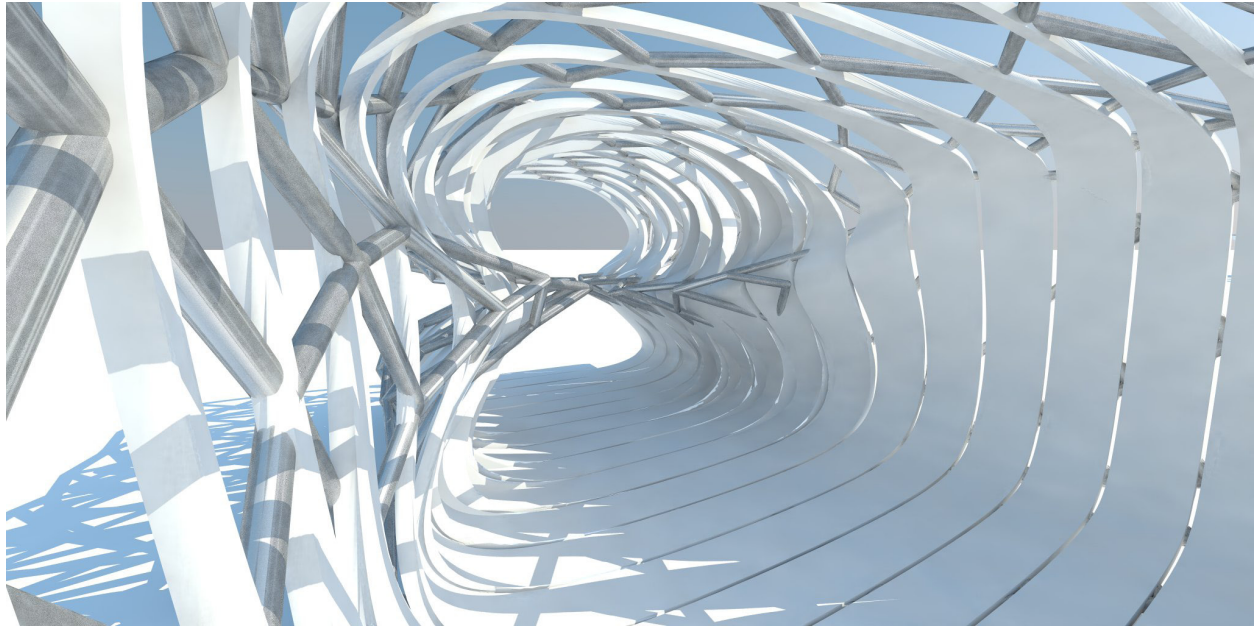

Fig. 21.1.7

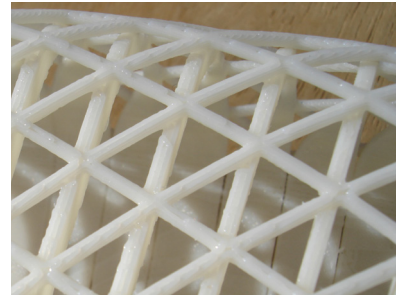
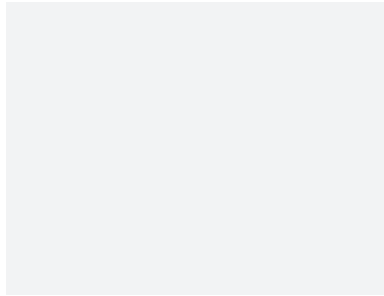

Fig. 22.1.1

Visualization, Fabrication and Testing

The analog model is the generator of form. The definition of an analog model is indicative of its form, structure, and its articulation of each loop. The digital model, reconstructed through the use of photography and digitized points, is not the same, but rather a translation of the analog crochet. The digital becomes a tool for visualization, exploration and fabrication. When the qualitative spaces of the analog model are defined, digitized and rebuilt virtually, it enables the designer to occupy, explore, and visually test the space. Through visualization, the digital model allows the architect to objectively judge the space and adjust the model in order to achieve the desired result. Unlike the analog model, digital space enables the suspension of natural laws that give rise to a freedom in the ability to observe, review, and refine the result.

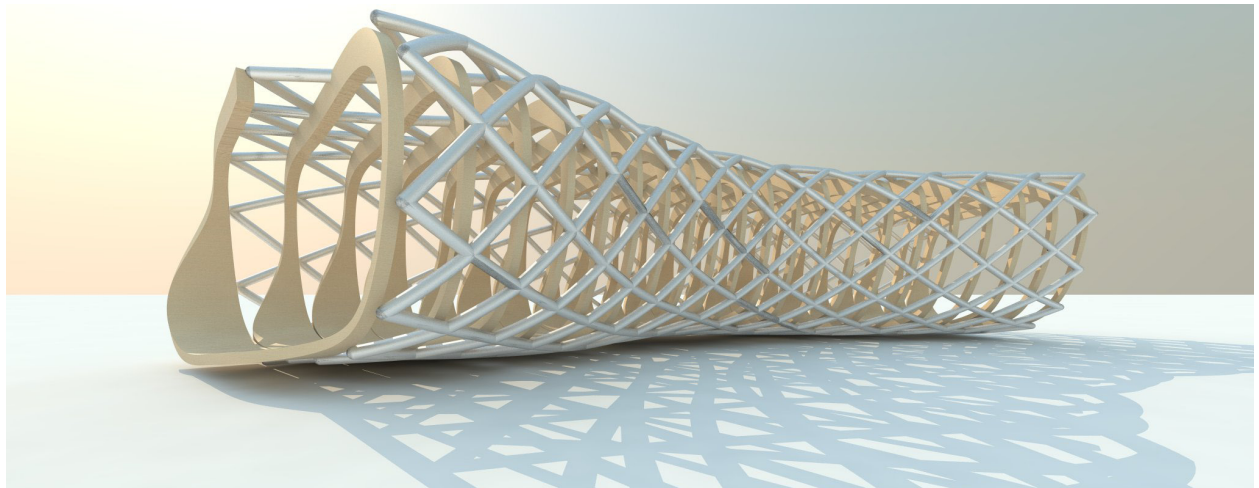

Fig. 22.1.2

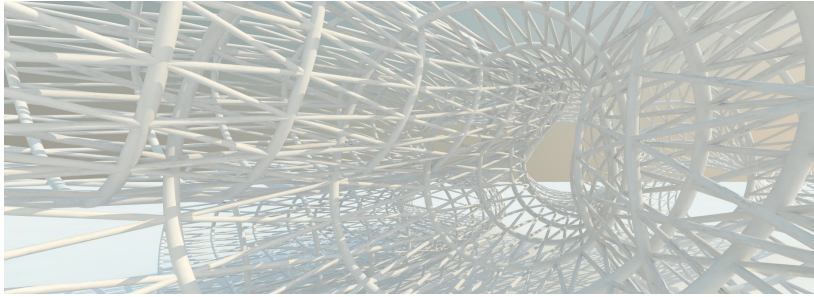

Fig. 22.2.1

“Virtual space becomes an arena for speculation and contemplation, for testing and turning, warping, morphing and animating spatial sequences that otherwise would remain static graphic images. Through its liquid nature, digital space becomes a contributor to the development of ideas and forms, not merely a passive host to preconceived shapes or prescribed software formats and outputs.” (Dollens, 9, D2A)

Visualization: The Digital

Visualization is one of the digital’s greatest tools. It enables the objective and critical observation of space and structure. After the digital reconstruction of the analog crochet model, questions arise regarding the realistic usability of the structure. The entire structure is porous and open. (Fig. 22.2.1) In its current state, the structure is not occupiable as there is no surface to walk. This is mediated through the employment of the digital tools. The helix is deformed, resulting in a walkable surface.

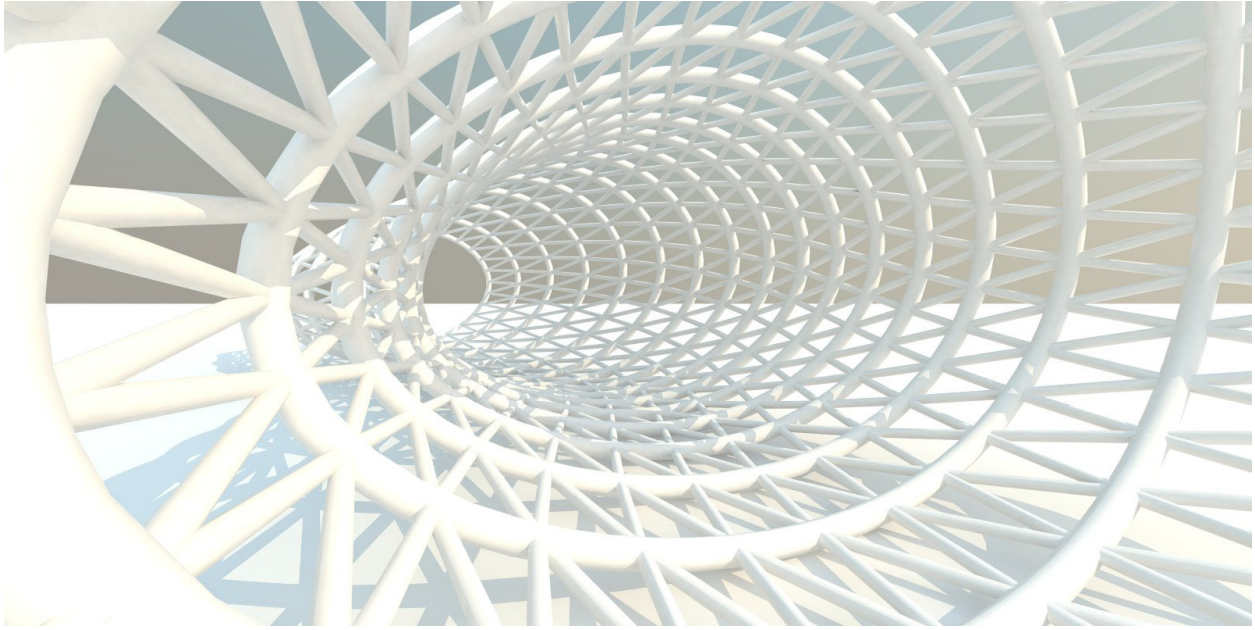
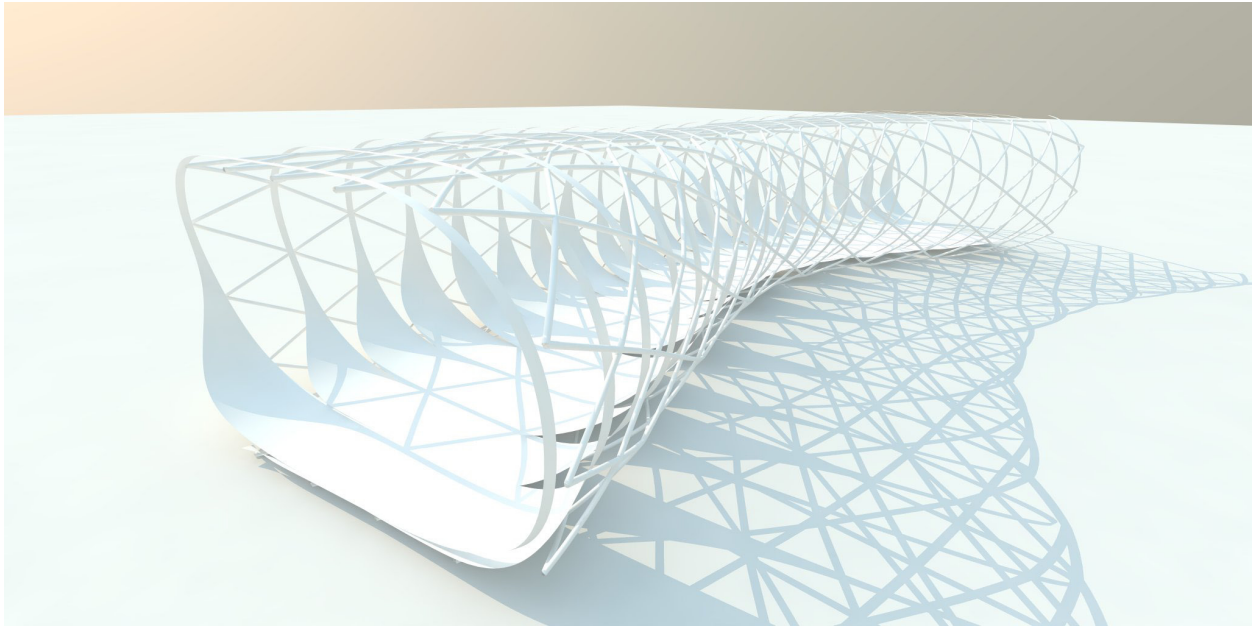

Fig. 22.2.2

Though visualization of the digital model does not solely exist in virtual space, the ability to realize or rapidly prototype a digital model and test a design idea is crucial to the understanding of the digital design. Constructing digital models through the use of rapid fabrication machines raises questions of thickness and materiality.



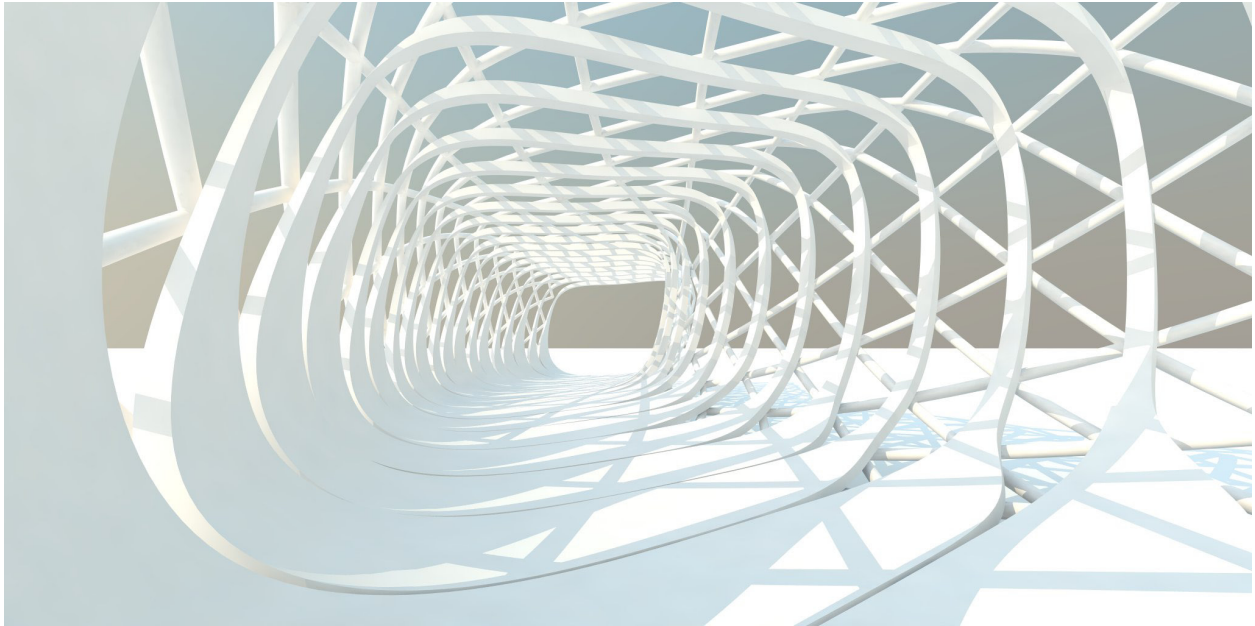

Fig. 22.2.3



Fig. 22.3.1

Fabrication: The Model

The use of prototyping and digital design through modeling can be used to illustrate relationships and aid in design decisions. In IL 25, Siegfried Gaß states that a model cannot represent all details and features of the original. Models can only contain the specific features that are deemed relevant for an evaluation or test. By reducing the model to select features, this abstraction can make it easier to gain information. The selection of the represented features is important in its evaluation as their selection can lead to unforeseen opportunities.

In fabricating the digital model, desired features can be determined by the method of rapid prototyping. Each prototyping technique will yield a different result and begin to influence the overall design of the digital model. The method of fabrication will define or omit details. By working with these technologies, rapid prototyping machines can lead to decisions in the overall execution of the design. However,

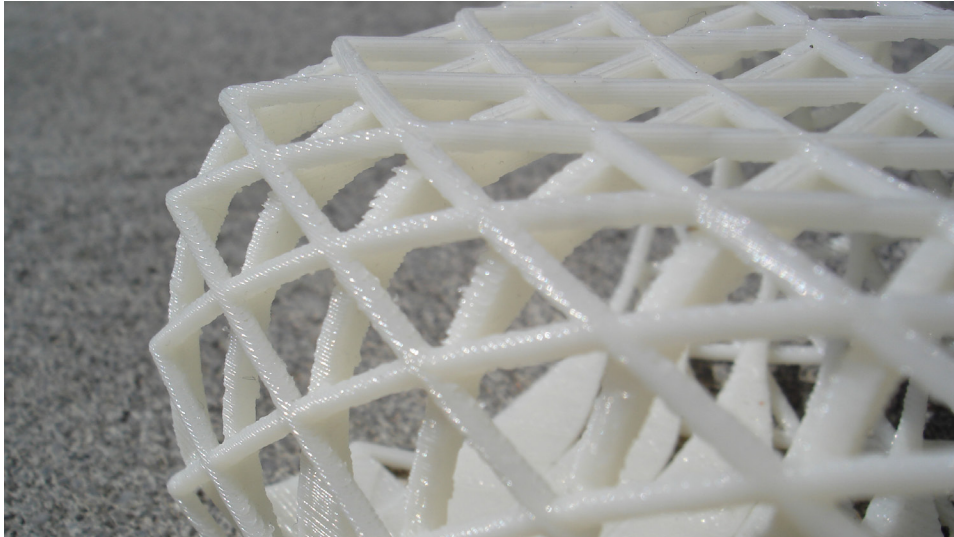

Fig. 22.3.2

these scale models can only be used for proof of concept and not necessarily used to fabricate the final design. Gaß clarifies this in the pragmatic feature of a model:

“Models are not clearly assigned to their originals; they perform their reproductive function only as a function of an acting person, at a given time and for a particular purpose. They can therefore be considered as universally valid and transferable only up to a point” (Gaß, 1.2, IL25)

Physical modeling requires the designer to think of material, tolerance, and assembly that leads to the further refinement of the concept. Choosing the rapid prototyping method brings up additional design decisions. To facilitate the success of the 3d print, both thickness and tolerance must be addressed.

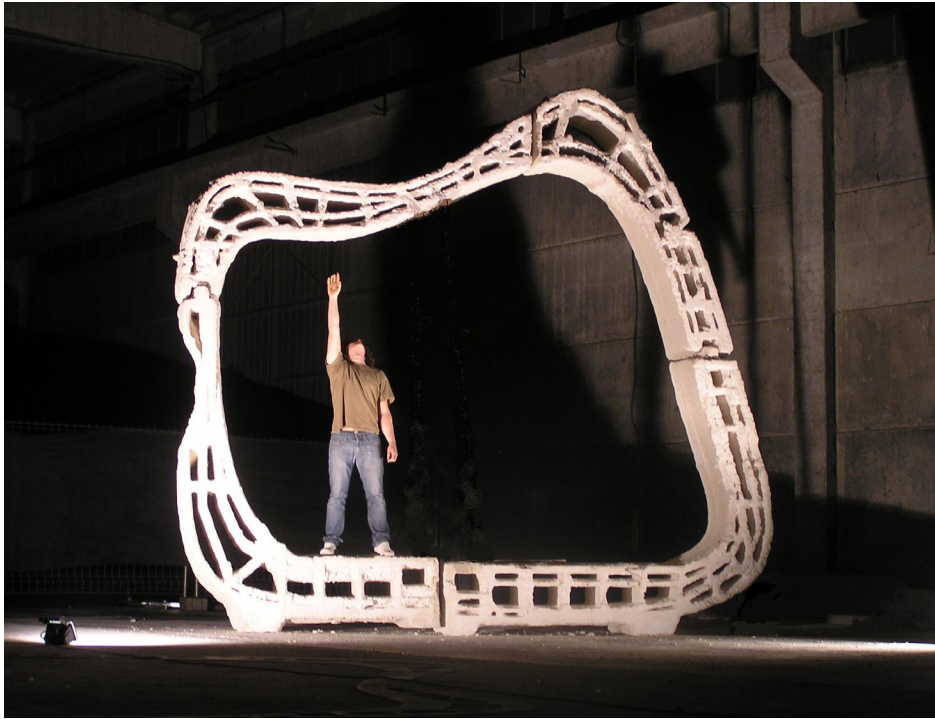

Fig. 22.3.3

In the 3d print, there is no distinction in materiality, the entire model is made from ABS plastic, thus the print becomes purely used for visualization and visual testing of the structure. Although, this method of 3D print prototyping at a large scale has been achieved by the Italian engineer, Enrico Dini. In using a similar concept to 3d printing and selective laser sintering, Dini has developed a large prototyping machine that constructs the digital model in layers (*Fig. 22.3.4*). However, in using such a machine, the final prototype is a homogeneous material. In order to maintain variety in construction techniques and material, different methods of fabrication must be studied and tested.

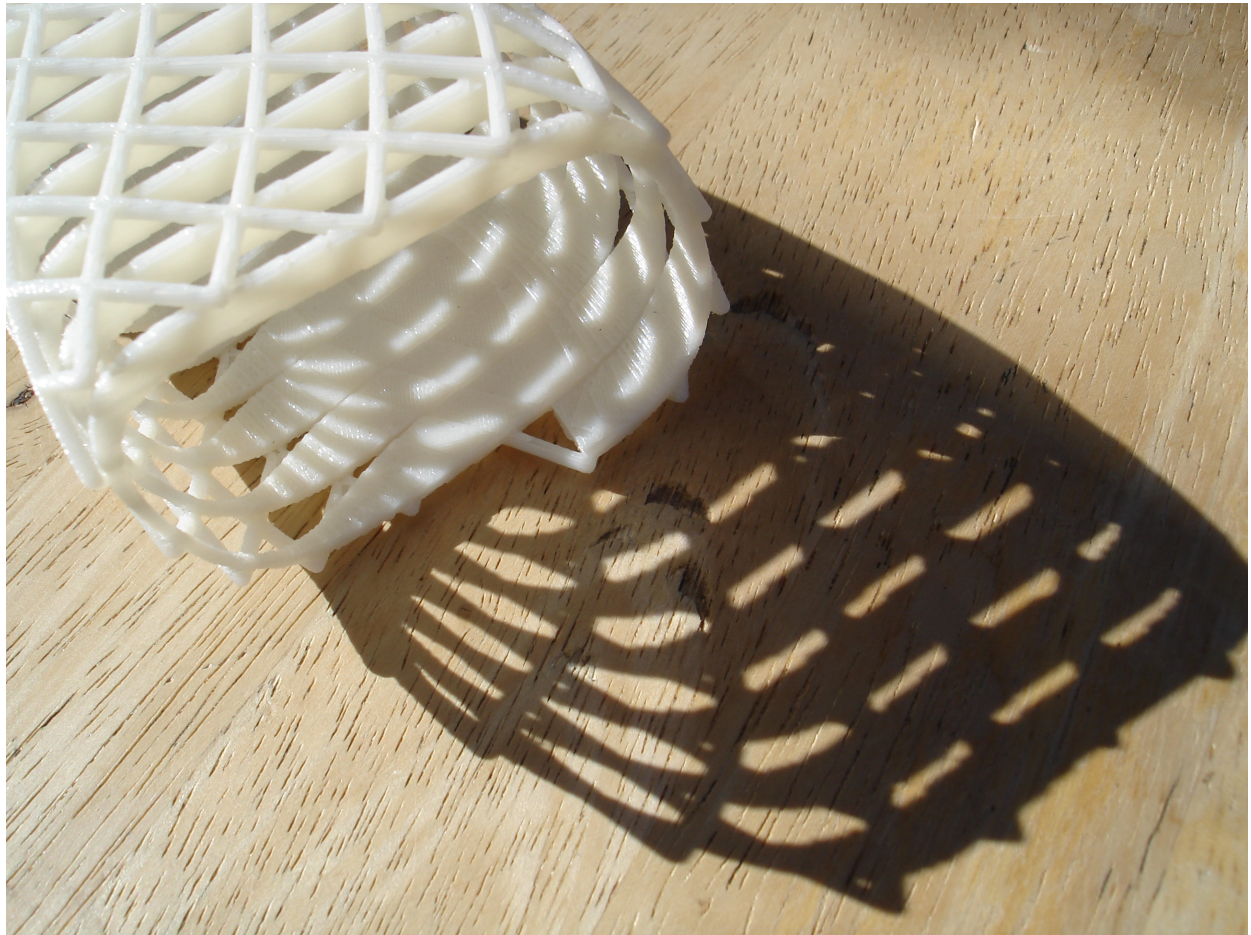

Fig. 22.3.4





Fig. 22.3.5

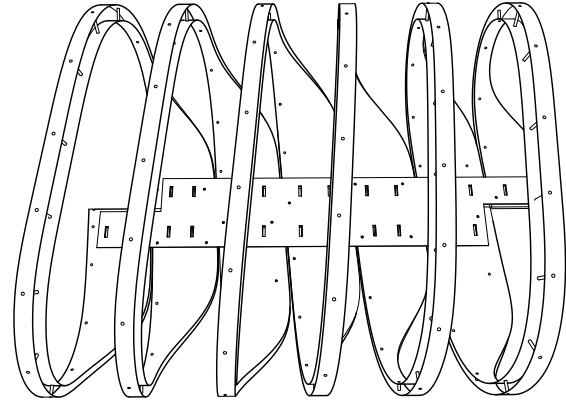

Fig. 22.3.6

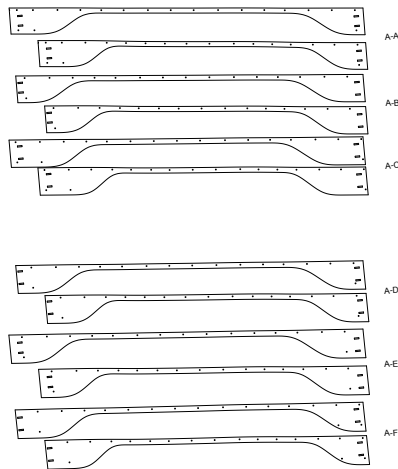

Fig. 22.3.7

In using a two dimensional rapid prototyping machine, the digital model can be constructed through a simplified method. Utilizing a LaserCMM, the unrolled helical surface can be cut out of a specified material. By selecting the helical surfaces in the digital model, this surface can be segmented and then unrolled. Unrolling the helix creates a two dimensional pattern that can be cut. (Fig. 22.3.7) Unlike the 3d print, the use of the LaserCMM requires assembly. To ensure the correct assembly, it is important to label the connections, or develop a pattern for construction. The resulting model is drastically different from the 3d print.

In the fabrication of the digital model through rapid prototyping, the method used directly influences the design. In fabrication, the digital never operates independently from actual reality.

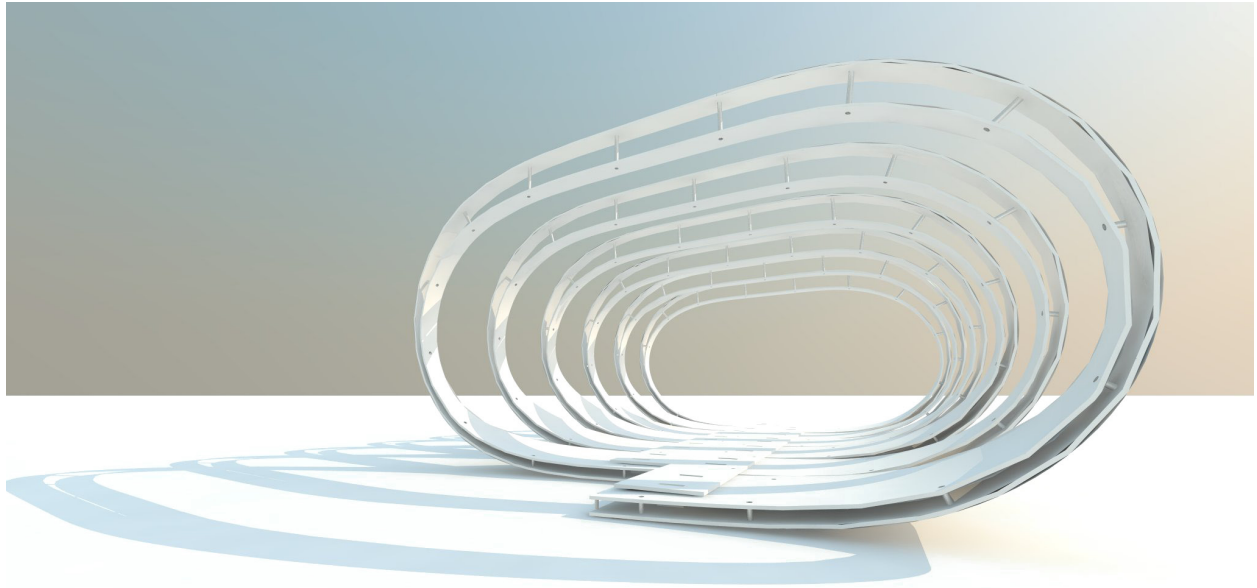

Fig. 22.3.8

The dialog between the two must be constant to achieve a refined result. The testing of a design concept follows the same rules as rapid prototyping. The methods of fabrication, engineering, construction, and standardization of materials all inform the design and the outcome.





Fig. 22.3.9

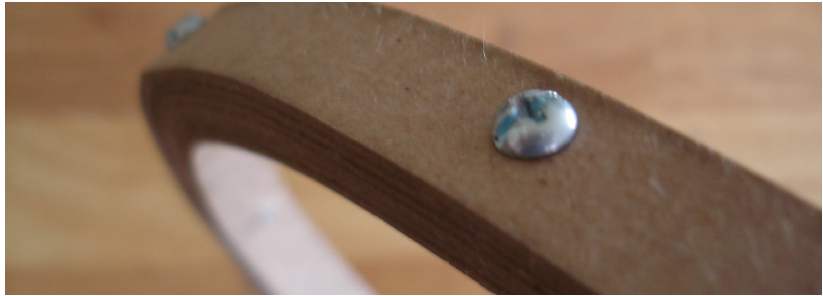
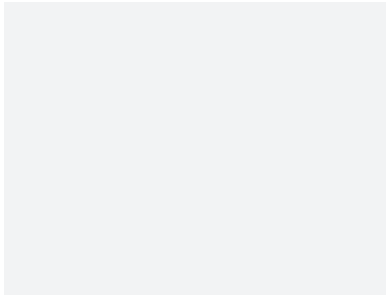

Fig. 22.4 .1

Testing: The Construction

The construction of both analog and digital models aid in the understanding and testing of the architectural structure. Scale models can be used to prove concepts and can continue to allow for emerging qualities within the construction technique.

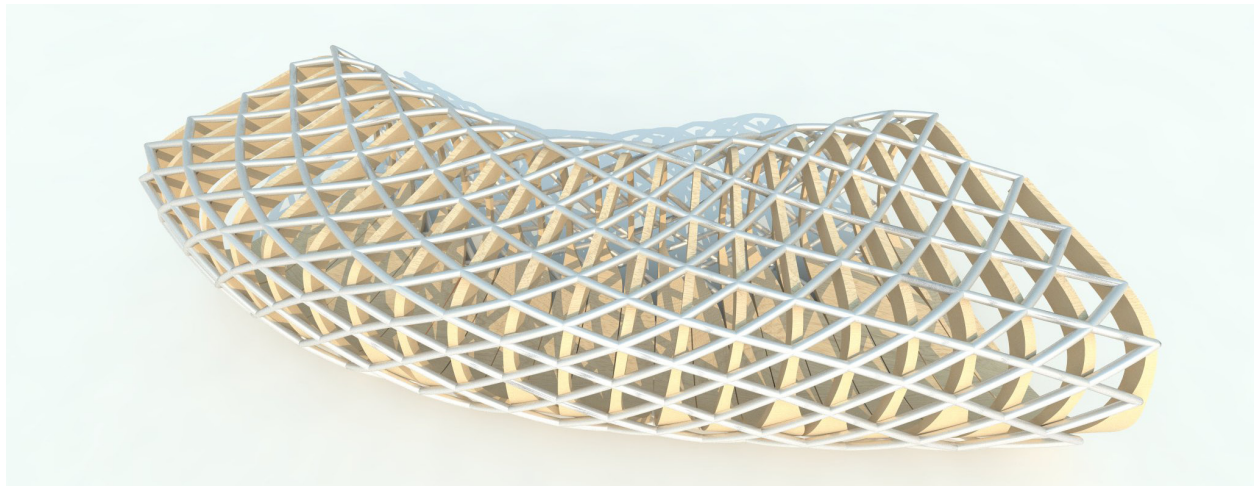
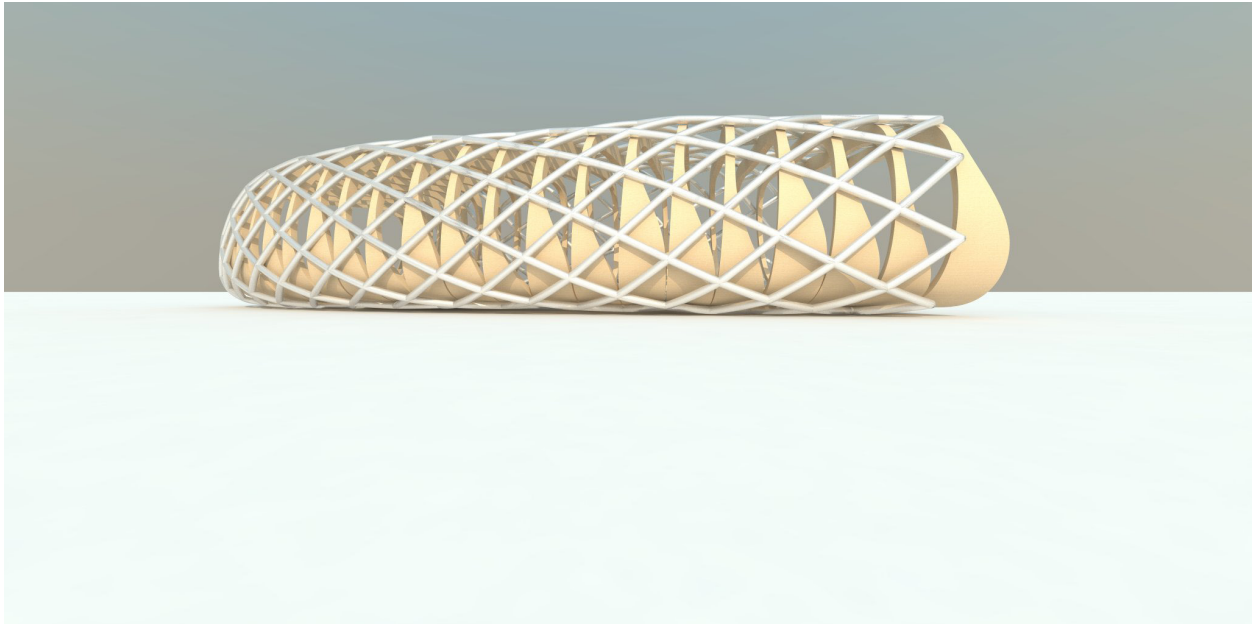

Fig. 22.4.2



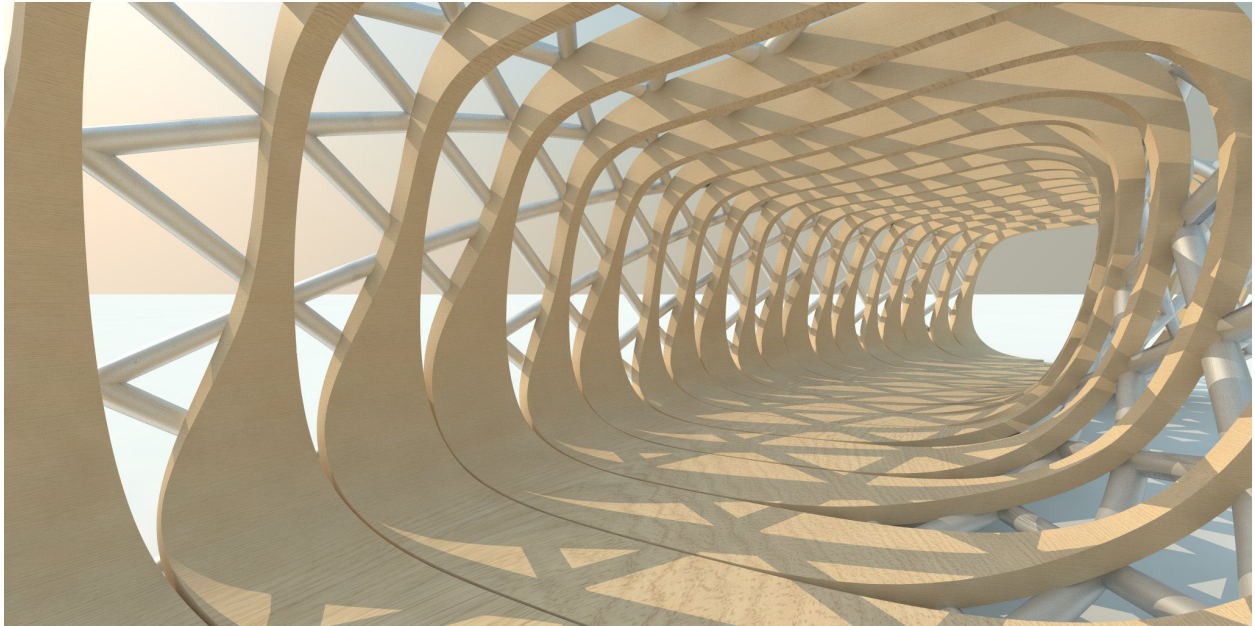

Fig. 22.4.3

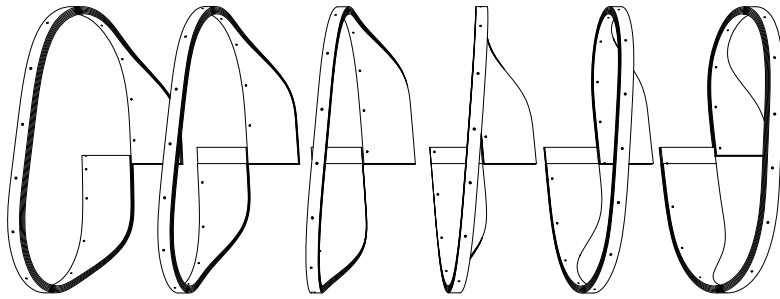

Fig. 22.4.4

Testing: The Helix

In the completion of the unrolled helical model, it becomes clear that this method is an effective and successful method of constructing the helical surface. However, in the first iteration, it is difficult to construct the curvature of the digital model. This is resolved in the second iteration through the offsetting and lamination of multiple helical surfaces.

In order to connect them, control points are cut out of the surface. These control points enable a perpendicular connection to be made. Like the analog spline, once these control points are connected by a perpendicular connection the material takes on the proper curvature of its digital counterpart. Effectively, this system becomes a laminated helical beam. In the scale model this concept is tested in chipboard, however, the helix is too flexible and needs stiffening. Stiffening of the helix is achieved by connecting each revolution to the next. The need for these connections is based on the material and method employed to construct the helix.

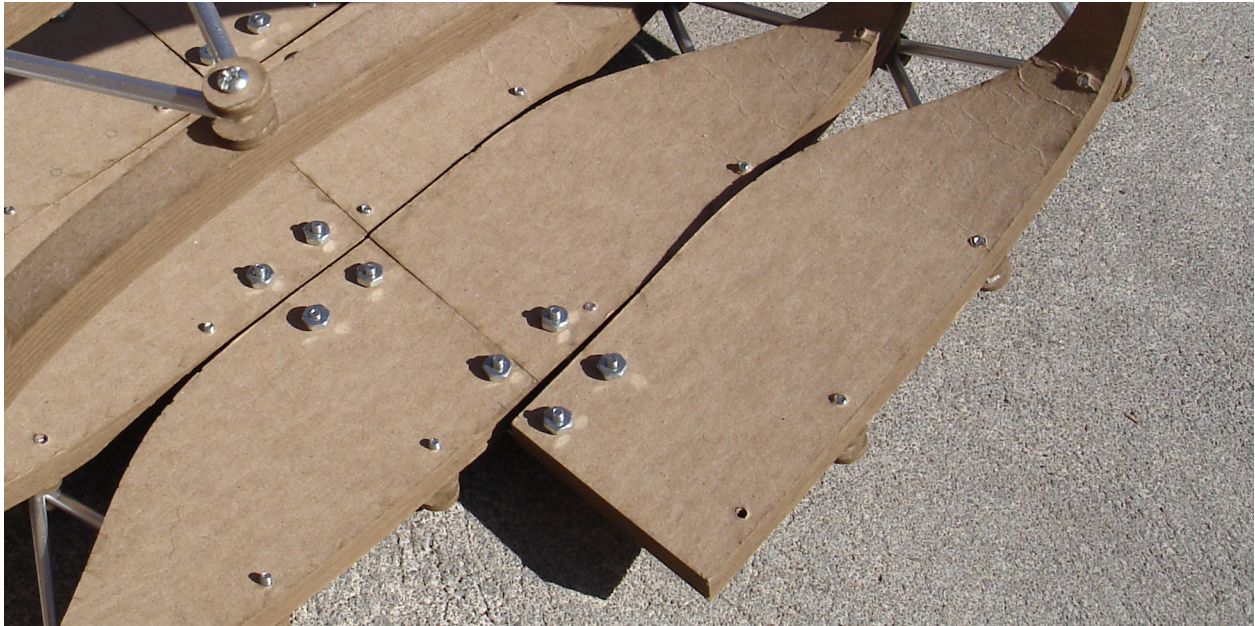

Fig. 22.4.5

The helical beam can be constructed using a variety of fabrication methods. By looking at large scale spin casting techniques, the beam could be cast as a single member. Such a method of fabrication would eliminate the need for these additional joint connections between each revolution.





Fig. 22.4.6

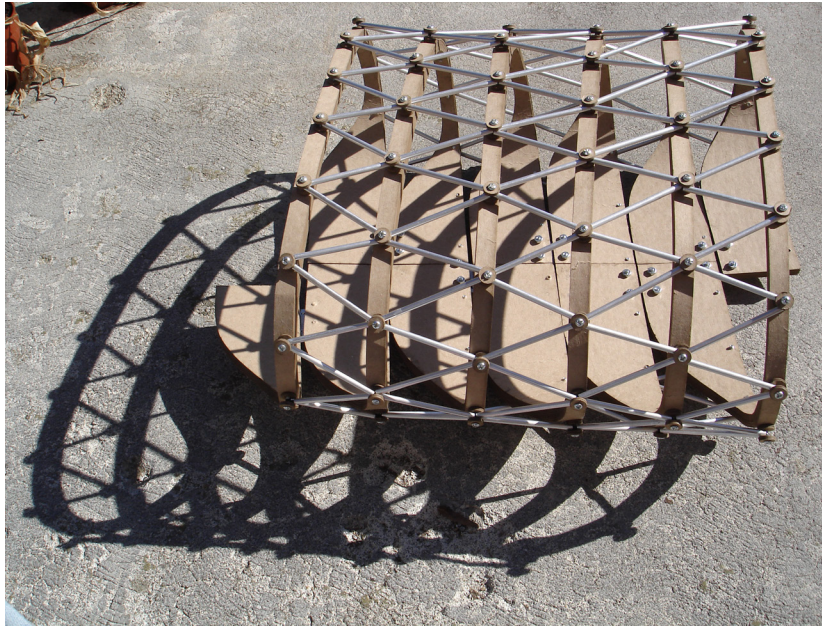



Fig. 22.4.7

The diagonal bracing members are connected to the nodes along the beam. In the physical model, these diagonal members are a dimensioned aluminum tube cut to a specific length. The members are secured to each node with an internal elastic band to pull each connecting node towards the center of the bracing member

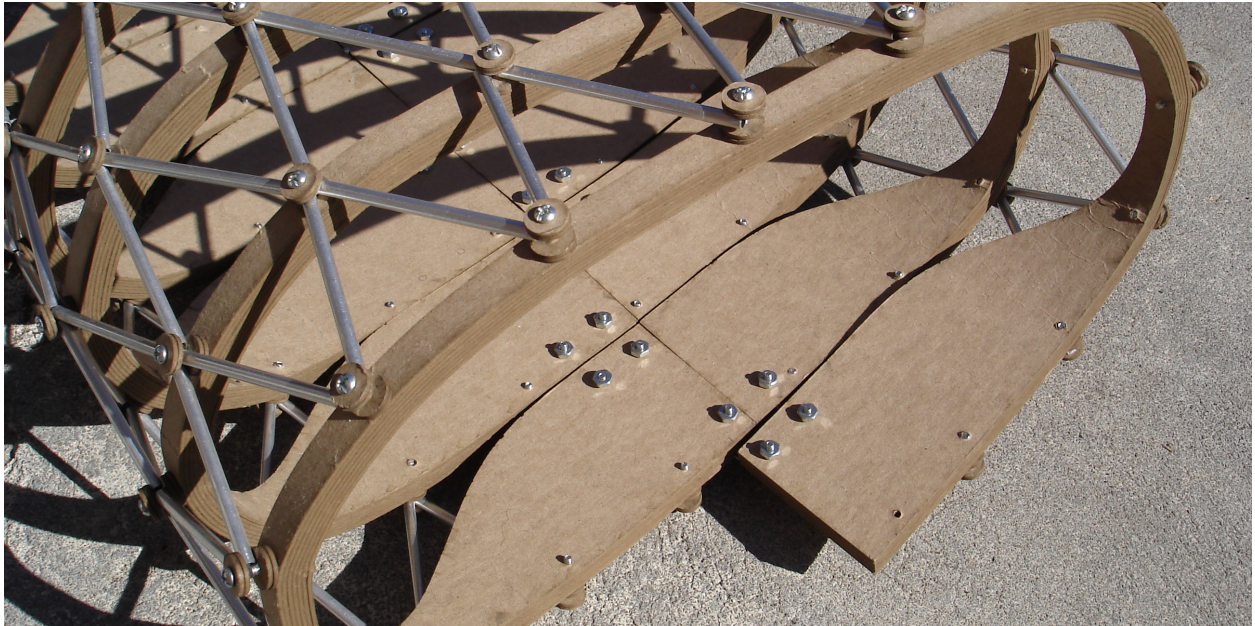



Fig. 22.4.8

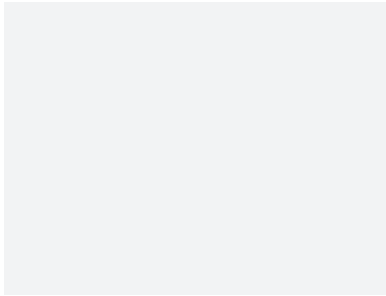

Fig. 22.4.9

Testing: The Bracing Connection

Design of the bracing system is crucial to the entire structure. Though the helical beam is self supporting, the bracing aids in the stability of the system. In order to construct and fabricate these connections, it is important to identify the role that these bracing members play and how the system can be successful in its role. In the scaled physical model, simple nodes are used to connect the bracing members between the helical revolutions. There is no need to design a customized node for each discrete connection so long as the bracing member has a range of motion.

Similar questions of construction arose in the development of the Son-O-House. Lars Spuybroek and his team addressed the method of enclosure through the use of standardized strips of expanded stainless steel. These strips were laid over ribbed structure based on a set of rules. (Fig. 22.4.10)

For the steel contractor we made a model and a brochure with rules and tips, but no drawings. The surface has an 'emergent pattern' and no predetermined layout, since everything depends on the position of the first strip, where the other strips follow either a closed hexagon or open hexagon rule. The first 50% of the surface is covered with an unmodified strip, the next 45% of the surface is covered with strips hand cut on the

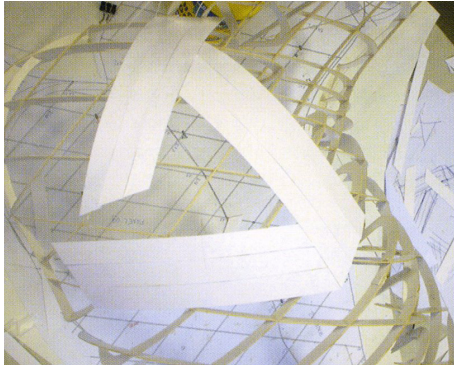

Fig. 22.4.10



Fig. 22.4.11

short end to fit and the last 5% is covered with strips cut on two or more sides. There is no waste. (Spuybroek, 186, Nox)

Spuybroek was able to embrace the possibility of emergence within the construction process. Instead of attempting to calculate all of the exceptions to the rule with digital tools, he allowed for the physical laborer to follow a set of logic to cover the surface. This logic is then employed in the design for the helical bracing.

Instead of defining a static geometry, that is specific for each individual connection along the helical path, the connection allows for the bracing to adjust based on its end points between each revolution. By doing this, the standardization of the connection piece becomes an effective solution where the only customization occurs in the length of each bracing membrane. This length can be calculated through the use of the digital software and can be manufactured to its specific length. Though emergence doesn't occur within the construction process, it occurs within the connection of the bracing members. The connection configures within the designed range of motion just as its analog crochet counterpart.

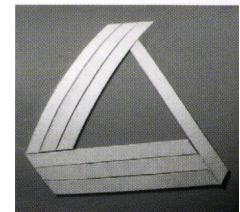
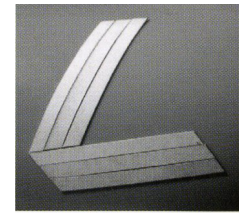

Fig. 22.4.12

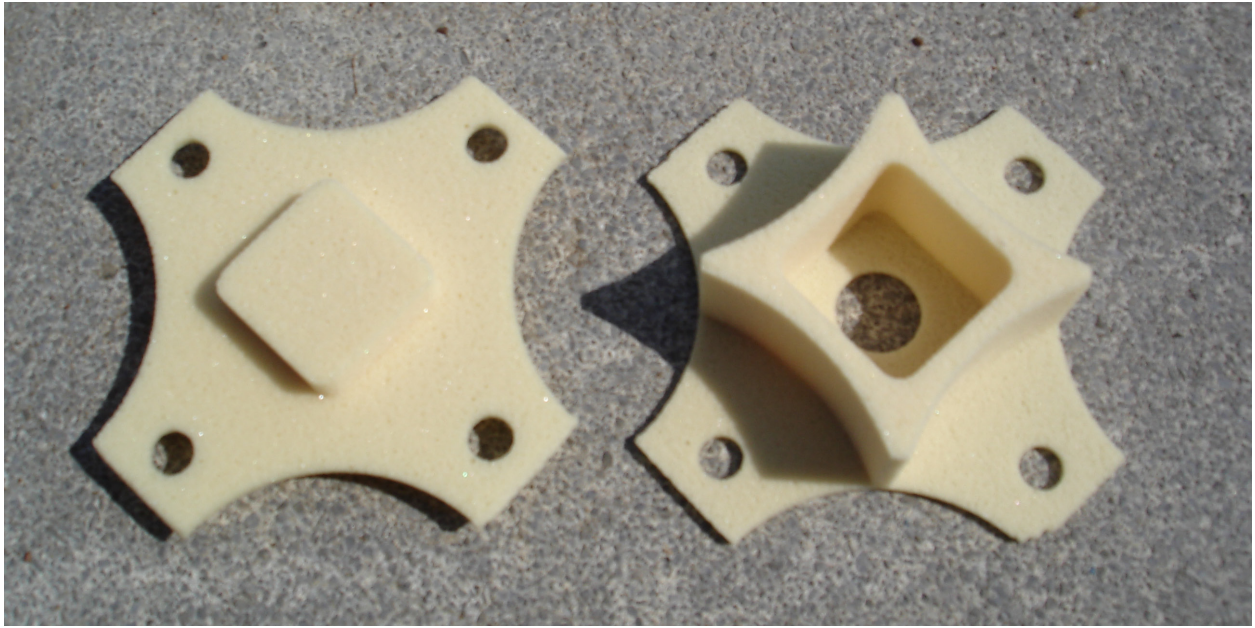
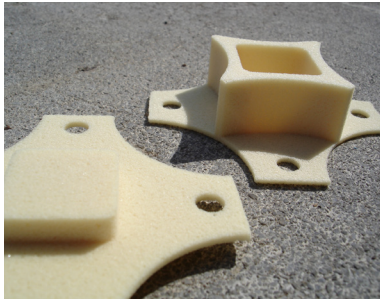

Fig. 22.4.13





The first iteration of the connection node is designed to use simple I-bolts to secure the bracing members. Though the I-bolts enable the range of motion required for the bracing, there is too much play in each connection.



Fig. 22.4.14

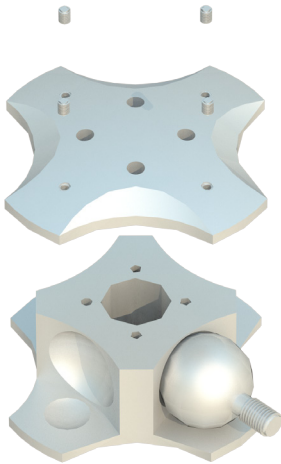
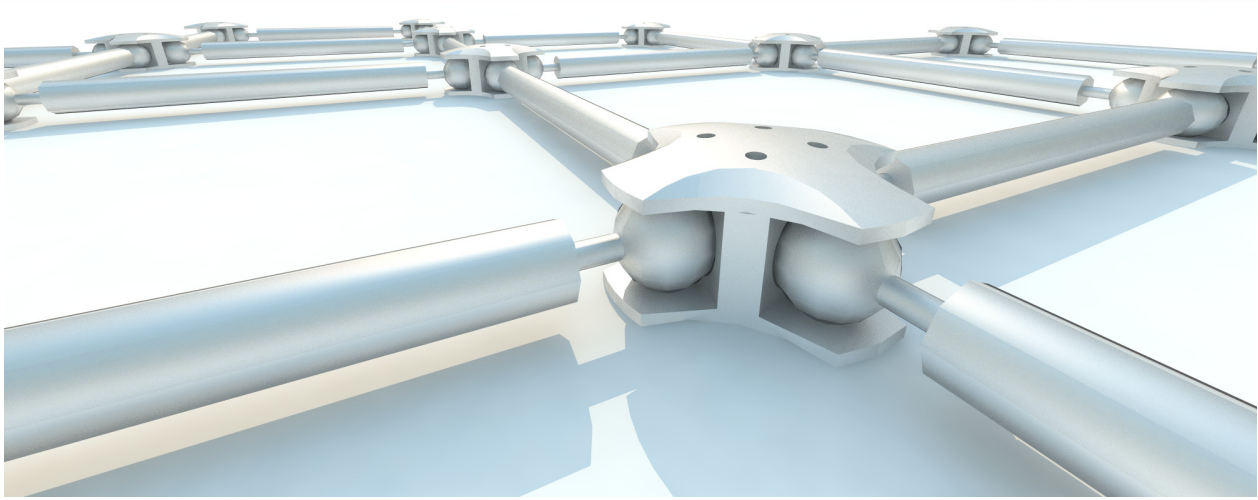

The second iteration of the bracing connection is constructed of a ball joint. Each bracing member has a ball located at the ends, the ball fits within the connection node secured to the helical beam. This connection is loose, however, within each node the ball joint can be tightened resulting in a static and solid bracing connection. By designing the node with the ball joint connection, it allows for each bracing member within the system to have a wide range of motion. This removes the requirement for a custom connection along the helix and results in a highly efficient and effective structure.

Fig. 22.4.15

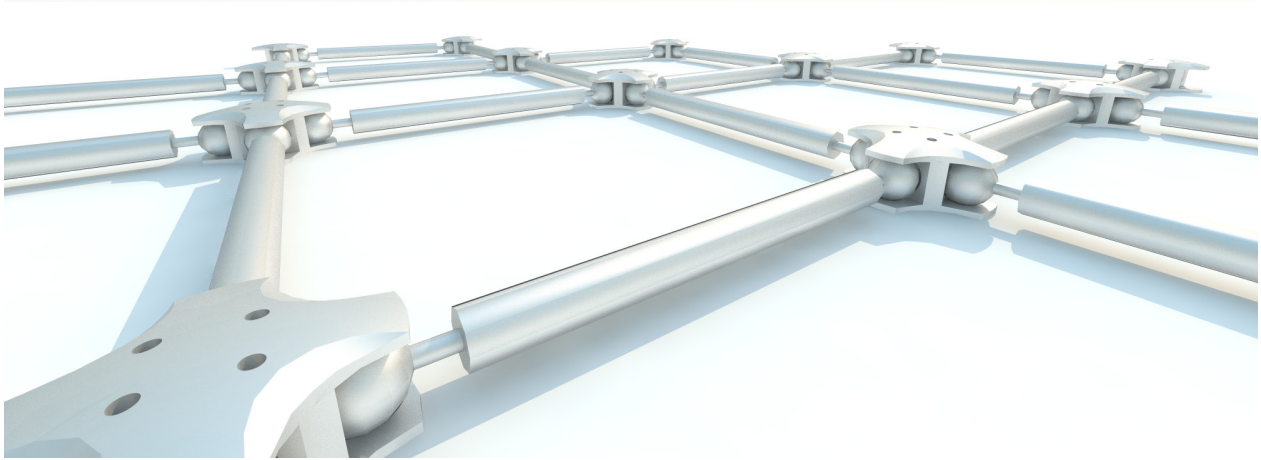

Fig. 22.4.16

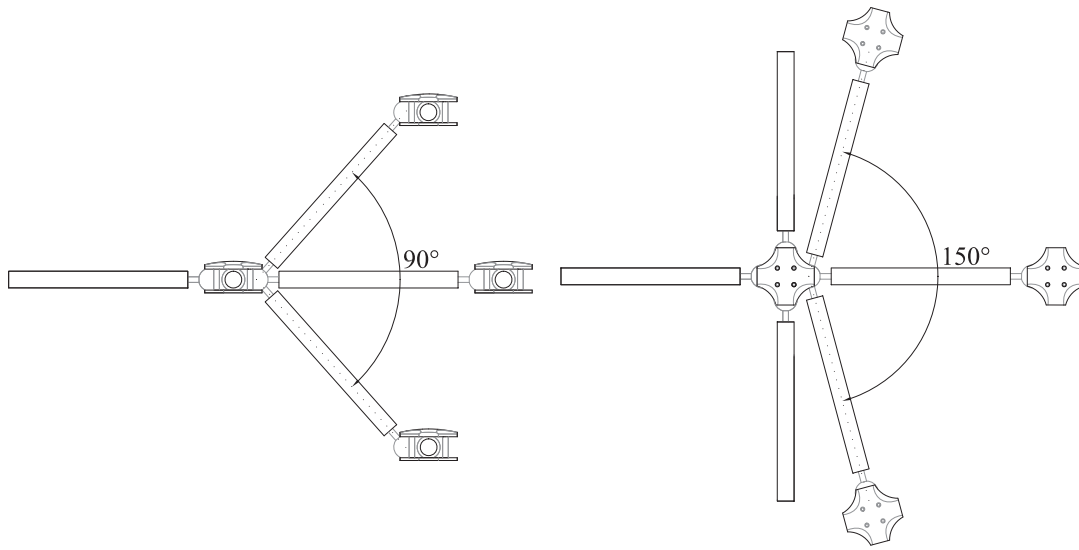

Fig. 22.4.17

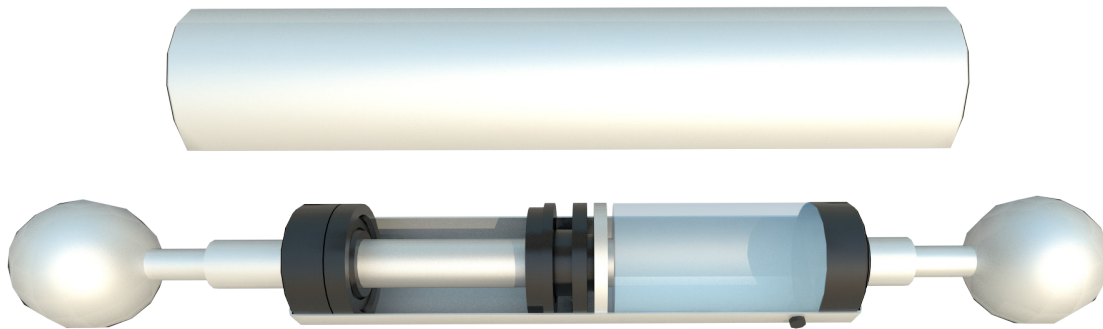

Fig. 22.4.18

Testing: The Bracing Member

In addition to the bracing connection, each member works towards stiffening the structure. This is achieved, by using pneumatic bracing members. Each member can be designed to be in tension or compression by the addition or subtraction of compressed argon. In certain segments of the structure, it is important that the bracing members be in tension and others in compression in order to achieve the designed result.

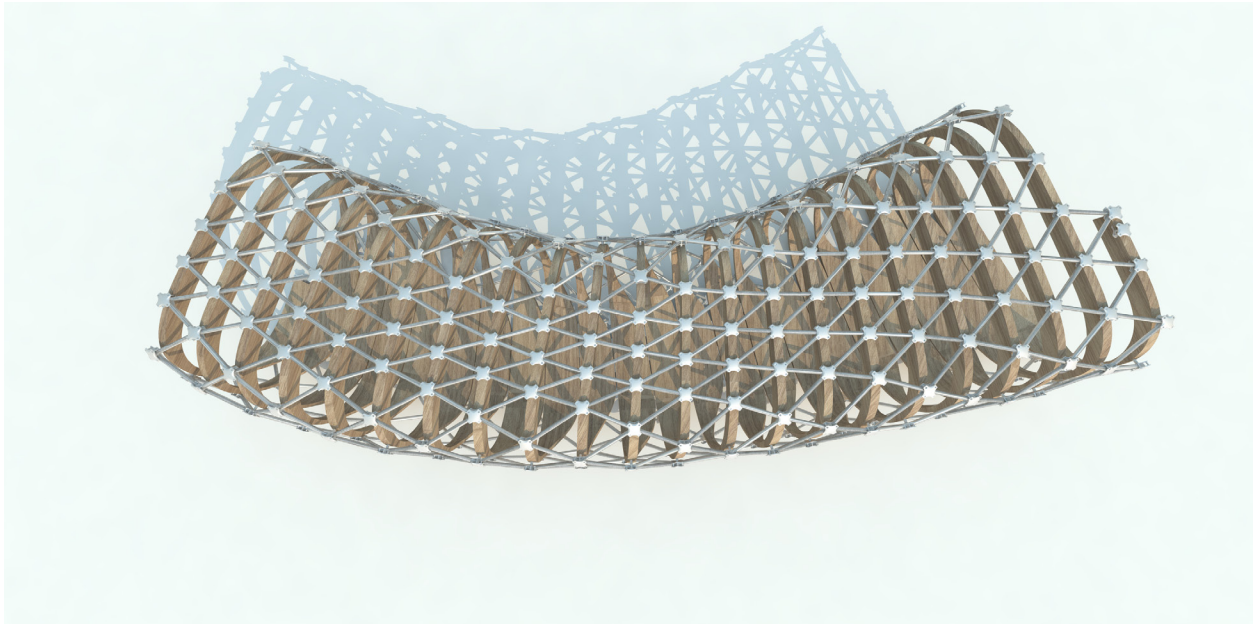
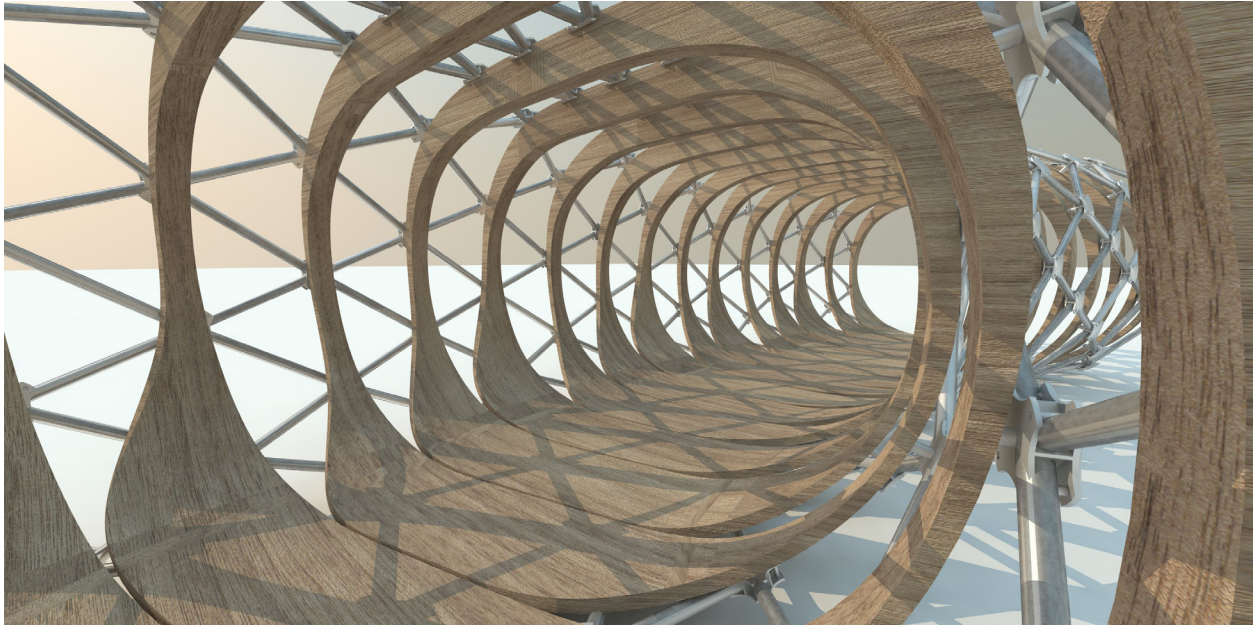

Fig. 22.4.1

The helical beam, connection nodes, and the pneumatic bracing members work in unison to create a beautiful structure that can be applied to a variety of forms without mass customization. The diagonal restraints of the crochet tube have been translated into an engineered system, that is a crucial component to the overall structure.



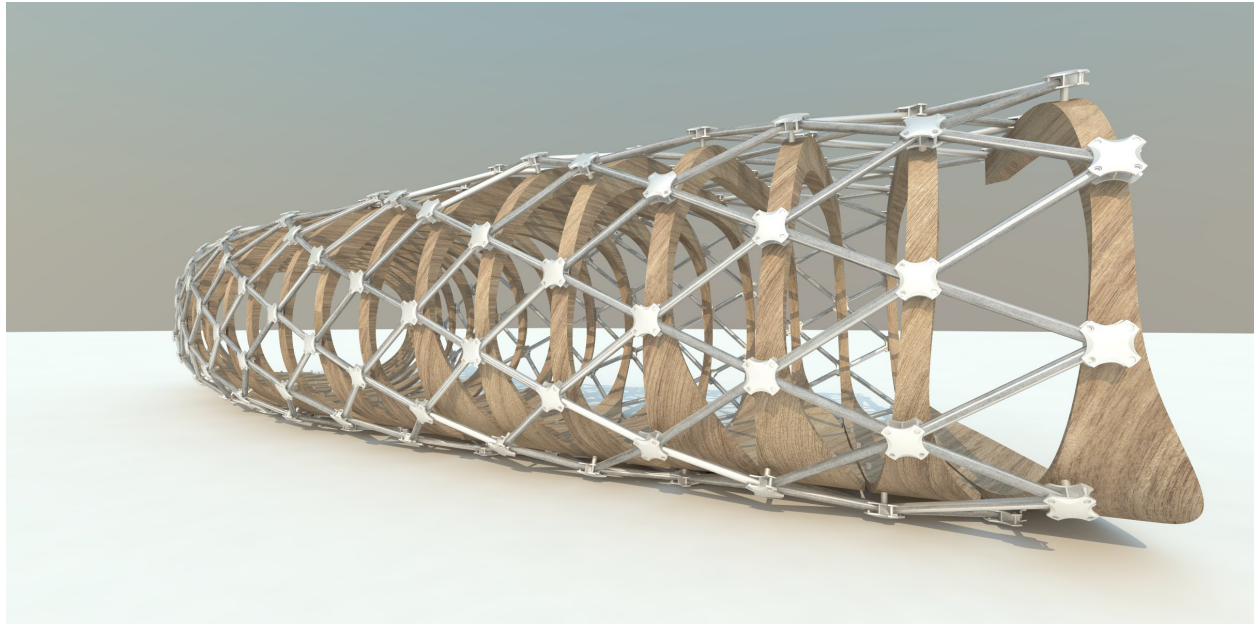
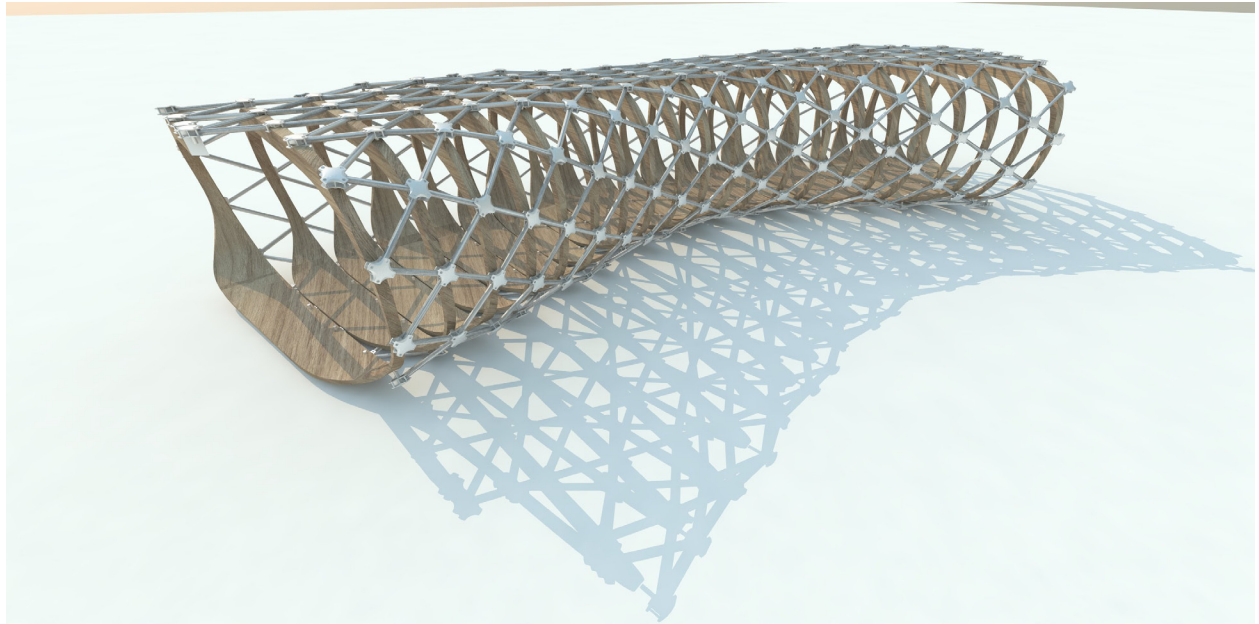

Fig. 22.4.20



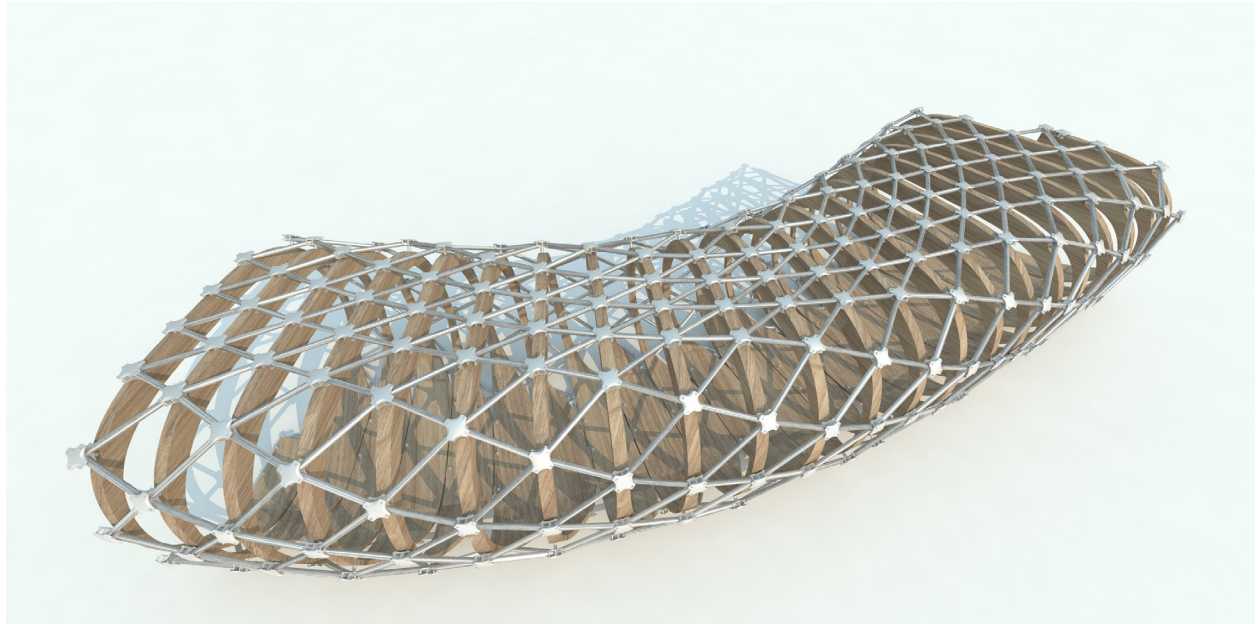
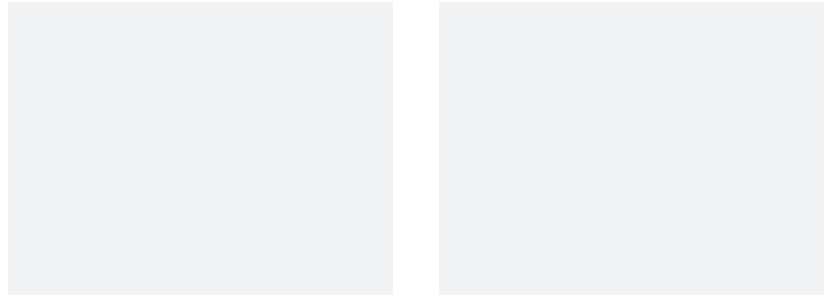

Fig. 22.4.21



Crochet Architecture

This structure, though influenced by crochet, is an abstraction. The analog crochet model is the medium to generate of form and is then translated into a static structure. This abstraction is born out of a necessity to use the analog model and digital tools to conceive and fabricate a physical structure through the use of current construction technologies. The future development of materials, techniques and technologies could remove the necessity for abstraction. In a few years, one might see large robotic arms looping a structural material, effectively crocheting architecture. Though this may sound fantastical, the idea of 3d printing full scale buildings and structures was only in the imaginations of architects, and now it is a reality. The only way to see is to continue the exploration in analog crochet and digital scripting tools.



Fig. 23.1.1

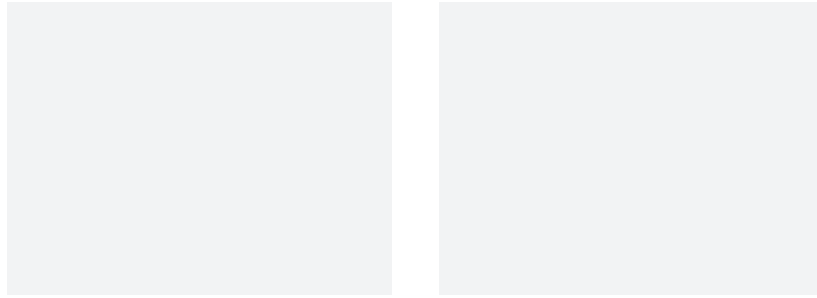

Conclusion

As a vehicle for these explorations, crochet is successful in exemplifying the relationships of part-to-whole, and bottom-up versus top-down design. By selecting this textile technique as the medium for exploration, it forces the mastery of the analog technique. Additionally, through the attempt to reconstruct this topological system digitally, it exemplifies both the advantages and limitations of the digital modeling tools.

The explorations within this book all stem from the desire to better understand a way of working that promotes the full use of both analog and digital techniques to develop a space, form, and structure. Their development is not based on a definitive



Fig. 24

process or methodology, but rather, emergent occurrences within an exploration and judgments of the designer. This bottom-up approach in working allows for unexpected outcomes to be judged on their successes and validity towards a defined or unknown goal.

Before we continue to develop and move one to innovative new technologies, it is important to look into the historical techniques of making. These analog techniques will better our understanding of the digital. Techniques such as crochet could possibly lead to even greater discoveries beyond the capabilities of the virtual environment. The only way to find out is to continue exploring the analog model.

Bibliography

- Alfoldy, Sandra. 2007. *NeoCraft: Modernity and The Crafts*. Halifax, N.S.: Press of the Nova Scotia College of Art and Design.
- Bach, Klaus, and Eda Schaur. *Pneus in Natur Und Technik*. Stuttgart: Institut für Leichte Flächentragwerke, 1977.
- Daina Taimina. "Crocheting the Hyperbolic Plane." Accessed August 22, 2010. <http://www.math.cornell.edu/~dwh/papers/crochet/crochet.html>
- Dollens, Dennis. D2a, Digital to Analog. Santa Fe: SITES, 2001.
- Friedrich Kiesler-Zentrum Wien, and Museum für Moderne Kunst (Frankfurt am Main, Germany). 2003. *Friedrich Kiesler: Endless House*. Ostfildern-Ruit, Deutschland: Hatje Cantz.
- S., Gaß,. Experiments. City: Institut für leichte Flächentragwerke, 1990.
- Geometry of Bending, The. Accessed September 15, 2010. <http://thegeometryofbending.blogspot.com/>
- Gilbert, Matt. "Crochet Pattern Generator" Accessed February 24, 2011 <http://www.mattgilbert.net/article/47/crochet-pattern-generator>
- Guilio Piacentino. "Knitting Patterns on a Surface in Grasshopper" Accessed June 22, 2010. <http://www.giuliopiacentino.com/knitting-pattern/>
- Jessica In, email message to A.G.W, June 22 2010
- Jessica In, "Plastic Futures 2 - a reflection" Folio collection of work produced during the Plastic Futures seminar at RMIT, Melbourne, Australia, 2009.
- Leisure Arts Inc. 1999. *Beginners Guide: Crochet Stitches & Easy Projects*. Little Rock, AR: Leisure Arts Inc

- Lynn, Greg. 1999. *Animate Form*. New York: Princeton Architectural Press.
- Margaret Wertheim “The Beautiful Math of Coral” Presented at TedTalk, New York, NY, February 2009.
- Osinga, Hine M, and Krauskopf, Bernd. *Crocheting the Lorenz manifold*. Bristol: University of Bristol, 2004.
- Otto, Frei, and Winfried Nerdinger. 2005. *Frei Otto: Complete Works : Lightweight Construction, Natural Design*. Basel: Birkhäuser
- Rahim, Ali. 2006. *Catalytic Formations: Architecture and Digital Design*. London: Taylor & Francis.
- Schaur, Eda, and Frei Otto. 1979. *Form, Kraft, Masse = Form, Force, Mass*. Stuttgart: Institut für Leichte Flächentragwerke
- Semper, Gottfried. 1989. *The Four Elements of Architecture and Other Writings*. Cambridge [England]: Cambridge University Press.
- Spuybroek, Lars. 2004. *Nox: Machining Architecture*. New York, N.Y.: Thames & Hudson.
- Spuybroek, Lars. 2009. *Research & Design: The Architecture of Variation*. New York: Thames & Hudson.
- Spuybroek, Lars. 2008. *The Architecture of Continuity: Essays and Conversations*. Rotterdam: V2 Pub.
- Tomlow, Jos, and Antonio Gaudí. 1989. *Das Modell: Antonio Gaudis Hängemodell und seine Rekonstruktion : neue Erkenntnisse zum Entwurf für die Kirche der Colonia Güell*. Stuttgart: Institut für Leichte Flächentragwerke

Additional Readings

- Abruzzo, Emily and Solomon, Johnathan D. 2006. *306090: Decoration*. Princeton, NJ: 306090, School of Architecture, Princeton University.
- Garcia, Mark. 2006. *Architextiles*. *Architectural Design*, v. 76, no. 6. London: Wiley-Academy.
- Iwamoto, Lisa. 2009. *Digital Fabrications: Architectural and Material Techniques*. New York: Princeton Architectural Press.
- Jones, Mary Eirwen. 1951. *The Romance of Lace*. London: Spring Books.
- Kolarevic, Branko, and Kevin R. Klinger. 2008. *Manufacturing Material Effects: Rethinking Design and Making in Architecture*. New York: Routledge.
- Leach, Neil, David Turnbull, and Chris Williams. 2004. *Digital Tectonics*. Chichester: Wiley-Academy.

Lynn, Greg. 2004. *Folding in Architecture*. Chichester, West Sussex: Wiley-Academy.

Oxman, Rivka, and Robert Oxman. 2010. *AD The New Structuralism: Design, Engineering and Architectural Technologies*. Hoboken, N.J.: Wiley.

Rahim, Ali, and Hina Jamelle. 2007. Elegance. *Patrik Schumacher. Arguing for Elegance*. Chichester, England: Wiley-Academy.

Rappaport, Nina. 2007. *Support and Resist: Structural Engineers and Design Innovation*. New York: Monacelli Press.

Sheil, Bob. 2008. *Protoarchitecture: Analogue and Digital Hybrids*. London: John Wiley.

Sakamoto, Tomoko, and Albert Ferré. 2008. *From control to design: parametric/algorithmic architecture*. Barcelona: Actar-D.

Image Credits

All images are by the author except those noted below

- Fig. 2.1 Spuybroek, Lars. 2004. *Nox: Machining Architecture*.
- Fig. 2.2 Schaur, Eda, and Frei Otto. 1979. *Form, Kraft, Masse = Form, force, mass*.
- Fig. 2.3 Tomlow, Jos, and Antonio Gaudí. 1989. *Das Modell: Antonio Gaudis Hängemodell und seine Rekonstruktion*
- Fig. 2.4 Bach, Klaus, and Eda Schaur. *Pneus in Natur Und Technik*. 1977.
- Fig. 3.1 Edison Duck. http://www.boatdesign.net/forums/attachments/boat-design/9544d1160221763-spline-weights-too-heavy-costly-delivery-2005511135441__mg_6229.jpg (accessed April 9, 2011.)
- Fig. 3.3 Shamrock Hull Drawings, 1920. <http://nuttysrave.blogspot.com/> (accessed April 1, 2011.)
- Fig. 3.4 Moran Shipyard, 1900. http://upload.wikimedia.org/wikipedia/commons/4/43/Inside_hull_of_ship_under_construction_in_Moran_shipyard_-_1900.jpg (accessed April 1, 2011)
- Fig. 4.1 Schaur, Eda, and Frei Otto. 1979. *Form, Kraft, Masse = Form, Force, Mass*.
- Fig. 4.2 Tomlow, Jos, and Antonio Gaudí. 1989. *Das Modell: Antonio Gaudis Hängemodell und seine Rekonstruktion*
- Fig. 4.3 Tomlow, Jos, and Antonio Gaudí. 1989. *Das Modell: Antonio Gaudis Hängemodell und seine Rekonstruktion*
- Fig. 5.1 Spuybroek, Lars. 2004. *Nox: Machining Architecture*.
- Fig. 5.2 Schaur, Eda, and Frei Otto. 1979. *Form, Kraft, Masse = Form, Force, Mass*.

- Fig. 6.1 Semper, Gottfried. 1989. *The Four Elements of Architecture and Other Writings*.
- Fig. 6.2 S., Gaß,. Experiments. City: Institut für leichte Flächentragwerke, 1990.
- Fig. 6.3 Semper, Gottfried. 1989. *The Four Elements of Architecture and Other Writings*.
- Fig. 7.1 Semper, Gottfried. 1989. *The Four Elements of Architecture and Other Writings*.
- Fig. 8.1 Daina Taimina. "Crocheting the Hyperbolic Plane." <http://www.math.cornell.edu/~dwh/papers/crochet/crochet.html> (Accessed August 22, 2010.)
- Fig. 9.1 Osinga, Hinke M, and Krauskopf, Bernd. Crocheting the Lorenz manifold.
- Fig. 9.2 Osinga, Hinke M, and Krauskopf, Bernd. Crocheting the Lorenz manifold.
- Fig. 9.3 Gilbert, Matt. "Crochet Pattern Generator" <http://www.mattgilbert.net/article/47/crochet-pattern-generator> (Accessed February 24, 2011.)
- Fig. 9.4 JOHO The Blog. "The Jacquard Loom" <http://www.hyperorg.com/blogger/2008/03/08/jacquard-loom/> (Accessed April 1, 2011)
- Fig. 9.5 Gilbert, Matt. "Crochet Pattern Generator" <http://www.mattgilbert.net/article/47/crochet-pattern-generator> (Accessed February 24, 2011.)
- Fig. 10.3 Lynn, Greg. 1999. Animate Form.
- Fig. 11.1 Leisure Arts Inc. 1999. Beginners Guide: Crochet Stitches & Easy Projects.

- Fig. 11.2 Leisure Arts Inc. 1999. *Beginners Guide: Crochet Stitches & Easy Projects*.
- Fig. 11.3 Leisure Arts Inc. 1999. *Beginners Guide: Crochet Stitches & Easy Projects*.
- Fig. 11.4 Leisure Arts Inc. 1999. *Beginners Guide: Crochet Stitches & Easy Projects*.
- Fig. 11.5 Leisure Arts Inc. 1999. *Beginners Guide: Crochet Stitches & Easy Projects*.
- Fig. 11.6 Leisure Arts Inc. 1999. *Beginners Guide: Crochet Stitches & Easy Projects*.
- Fig. 11.8 Leisure Arts Inc. 1999. *Beginners Guide: Crochet Stitches & Easy Projects*.
- Fig. 11.10 Leisure Arts Inc. 1999. *Beginners Guide: Crochet Stitches & Easy Projects*.
- Fig. 11.12 Leisure Arts Inc. 1999. *Beginners Guide: Crochet Stitches & Easy Projects*.
- Fig. 11.14 Leisure Arts Inc. 1999. *Beginners Guide: Crochet Stitches & Easy Projects*.
- Fig. 11.16 Leisure Arts Inc. 1999. *Beginners Guide: Crochet Stitches & Easy Projects*.
- Fig. 13.1.2 Kwangho Lee. "Obsession" <http://break4fun.zarke.net/wow/kwangho-lee-obsession.html> (Accessed September 30, 2010)
- Fig. 13.1.3 Kate Pokorny. "Crochet Yurt" <http://yurtalert.com/about/> (Accessed September 30, 2010)
- Fig. 13.1.4 Kate Pokorny. "Yurt Sketch" Email from Kate Pokorny to Author

- Fig. 13.1.5 Rockpool Candy. “Cor Blimey Crochet!” http://www.rockpoolcandy.com/photos/extreme_crochet_at_the_tu/index.html (Accessed September 30, 2010)
- Fig. 14.2.2 Lynn, Greg. 1999. *Animate Form*.
- Fig. 14.2.7 Guilio Piacentino. “Knitting Patterns on a Surface in Grasshopper” <http://www.giuliopiacentino.com/knitting-pattern/> (Accessed June 22, 2010)
- Fig. 14.2.8 Guilio Piacentino. “Knitting Patterns on a Surface in Grasshopper” <http://www.giuliopiacentino.com/knitting-pattern/> (Accessed June 22, 2010)
- Fig. 14.2.9 Guilio Piacentino. “Knitting Patterns on a Surface in Grasshopper” <http://www.giuliopiacentino.com/knitting-pattern/> (Accessed June 22, 2010)
- Fig. 14.2.10 Guilio Piacentino. “Knitting Patterns on a Surface in Grasshopper” <http://www.giuliopiacentino.com/knitting-pattern/> (Accessed June 22, 2010)
- Fig. 15.1.4 S., Gaß,. *Experiments*. City: Institut für leichte Flächentragwerke, 1990.
- Fig. 15.1.5 Bach, Klaus, and Eda Schaur. *Pneus in Natur Und Technik*.
- Fig. 16.1.2 Friedrich Kiesler-Zentrum Wien, and Museum für Moderne Kunst (Frankfurt am Main, Germany). 2003. *Friedrich Kiesler: Endless House*.
- Fig. 16.1.3 Spuybroek, Lars. 2004. *Nox: Machining Architecture*.
- Fig. 16.1.4 Spuybroek, Lars. 2004. *Nox: Machining Architecture*.
- Fig. 17.2.3 S., Gaß,. *Experiments*. City: Institut für leichte Flächentragwerke, 1990.
- Fig. 18.2.1 Leisure Arts Inc. 1999. *Beginners Guide: Crochet Stitches & Easy Projects*.

- Fig. 19.1.1 Friedrich Kiesler-Zentrum Wien, and Museum für Moderne Kunst (Frankfurt am Main, Germany). 2003. *Friedrich Kiesler: Endless House*.
- Fig. 19.1.2 Friedrich Kiesler-Zentrum Wien, and Museum für Moderne Kunst (Frankfurt am Main, Germany). 2003. *Friedrich Kiesler: Endless House*.
- Fig. 20.2.1 Geometry of Bending, The. Accessed September 15, 2010. <http://thegeometryofbending.blogspot.com/>
- Fig. 20.2.2 Geometry of Bending, The. <http://thegeometryofbending.blogspot.com/> (Accessed September 15, 2010.)
- Fig. 20.2.3 Geometry of Bending, The. Accessed September 15, 2010. <http://thegeometryofbending.blogspot.com/>
- Fig. 20.3.1 S., Gaß,. Experiments. City: Institut für leichte Flächentragwerke, 1990.
- Fig. 22.3.4 SolidSmack, Large Scale 3D Print. <http://www.solidsmack.com/fabrication/enrico-dini-big-freeform-architecture-3d-print-sardinia-villa-rocce/> (Accessed April 1, 2011)
- Fig. 22.4.10 Spuybroek, Lars. 2004. *Nox: Machining Architecture*.
- Fig. 22.4.11 Spuybroek, Lars. 2004. *Nox: Machining Architecture*.
- Fig. 22.4.12 Spuybroek, Lars. 2004. *Nox: Machining Architecture*.