

Factors Affecting Deployment Strategies for an LMDS System in a Rural Commercial Environment

By
Michael D. Lei

Thesis submitted to the Faculty of the Virginia Polytechnic Institute and State University

in partial fulfillment of the requirements for the degree of

Master of Science

in

Electrical Engineering

APPROVED:

Dr. Charles W. Bostian, Committee Chair

Dr. Timothy Pratt

Dr. Dennis Sweeney

April 27, 2001
Blacksburg, Virginia

Keywords: LMDS, Local Multipoint Distribution Services, Deployment Strategy

Copyright © 2001 by Michael D. Lei

Factors Affecting Deployment Strategies for an LMDS System in a Rural Commercial Environment

Michael D. Lei

Charles W. Bostian, Committee Chairman

Electrical Engineering

(ABSTRACT)

The recent allocation and auctioning of the largest spectrum currently available has positioned Local Multipoint Distribution Service (LMDS) technology as a major contender in the race to provide broadband connectivity to customers. With the focus on solving the “Last Mile” problem, LMDS provides a significant reduction in both the time it takes for system deployment as well as the cost of the implementation. However, as with all emerging technologies, the lack of standardization and the risks involved in being the pioneer of an emerging market have resulted in a slower commercialization of such systems.

The issues mentioned above served as the catalyst for this paper, to examine the factors that affect deployment strategies for an LMDS system in a rural commercial environment. In order to provide a better understanding of this technology, a review on the background issues in the areas of terrain, coverage/capacity, and networking will be presented. By evaluating these criteria, a strategy that can be employed to facilitate the implementation of LMDS systems is generated. Finally, the application of these methodologies will be demonstrated on a case study performed for a commercial environment in the county of South Boston, Virginia. Through evaluating the possible designs and the feasibility of the business case, it was determined that a point-to-multipoint system will best match the needs of the proposed location.

Acknowledgements

I would like to express my sincere thanks and gratitude to my advisor, Dr. Charles Bostian, and my committee members, Dr. Timothy Pratt and Dr. Dennis Sweeney. Dr. Bostian has been instrumental to both the success and completion of this thesis. His support and inspiration has helped in refining and perfecting my skills as an Electrical Engineer.

I would also like to thank my friends/peers at the Center for Wireless Telecommunications (CWT) for their support and many laughs in our day-to-day encounters. Many thanks also goes to my friends: Chin Tan, Andy Beegan, Adelia Veldez, and Marie McDonald for making the stay at Virginia Tech a most enjoyable and memorable experience.

My deepest thanks and appreciation to my parents and sister for their endless love and support. It is their encouraging spirit that has allowed me to persevere and complete yet another milestone in my life.

Last but not least, I would like to thank my lord and savior Jesus Christ in whom I can do all things.

Thesis Content

1 Introduction

1.1	Background.....	1
1.2	Document Overview.....	1

2 Overview of LMDS

2.1	Advantages/Disadvantages.....	5
2.2	Applications of LMDS.....	7
2.3	Bandwidth Allocation.....	8
2.4	System specifications.....	8
2.4.1	Point-to-Multipoint (PMP).....	9
2.4.2	Mesh.....	12

3 System Deployment Strategy

3.1	Terrestrial issues.....	18
3.1.1	Obstruction.....	18
3.1.2	Rain.....	22
3.1.3	Foliage.....	29
3.2	Coverage/Capacity.....	32
3.2.1	Multiple access techniques.....	32
3.2.2	Modulation techniques.....	34
3.2.3	Duplexing techniques.....	36

3.2.4	Reliability.....	37
3.2.5	BER limitations.....	39
3.2.6	Cell Site Planning	42
3.2.7	User/Area.....	47
3.2.8	PMP vs. Mesh.....	48
3.2.9	Link/Power Budget.....	50
3.3	Network Issues.....	55
3.3.1	Service Provided.....	55
3.3.2	Connectivity.....	56
3.3.3	Quality of Service (QoS).....	57

4 Deployment in a Commercial Environment (South Boston): A Case Study

4.1	Introduction.....	63
4.2	Approach.....	65
4.3	System/Customer Requirement.....	67
4.4	User Connectivity.....	68
4.5	Wide Area Network Connectivity (WAN).....	69
4.6	Geographic Considerations.....	71
4.7	Technical Design.....	72
4.7.1	PMP system.....	73
4.7.2	Mesh system.....	86
4.8	System performance/ Link Budget.....	89

4.9	Additional Design Concerns.....	91
4.10	Recommendation for system architecture.....	94
5	Business Strategy	
5.1	Exploring potential markets.....	95
5.2	Equipment Costs/Vendors.....	96
5.3	Pricing Strategy.....	97
5.4	Application of Business Strategy to Case Study.....	97
5.5	Conclusion of Financial Analysis.....	107
6	Conclusion	108
7	References	110

List of Figures

2.1 - Illustration of an LMDS Network.....	4
2.2 - PMP LMDS Layout.....	10
2.3 - Ethernet Application.....	10
2.4 - T1 Application.....	10
2.5 - CPE/Remote Unit.....	11
2.6 - Mesh Network.....	13
3.1 - Deployment Strategy Block Diagram.....	17
3.2 - Knife-Edge Diffraction.....	19
3.3 - Knife-Edge Diffraction Gain as a Function of Fresnel Diffraction Parameter v	20
3.4 - Fresnel Zones.....	21
3.5 - Diffraction Model for a 90° Building.....	22
3.6 - Rain Zone Regions- Americas.....	26
3.7 - Rain Zone Regions- Europe, Africa.....	27
3.8 - Rain Zone Regions, Asia.....	28

3.9 - Comparison of Measured Attenuation Rate with Nonzero Gradient.....	31
3.10 - TDMA Scheme.....	33
3.11 - FDMA Scheme	24
3.12 - Quadrature Display for 16-QAM.....	36
3.13 - TDD.....	37
3.14 - FDD.....	38
3.15 - Bit Error Rates for PSK and QAM Systems.....	41
3.16 - BER again Signal-to-noise for Coded and Uncoded Data Streams.....	42
3.17 - Coverage vs. Antenna Height and Hub Spacing.....	43
3.18 - Hexagonal Cell Reuse Pattern.....	44
3.19 - LMDS Frequency Plan for Maximum Coverage.....	45
3.20 - LMDS Frequency Plan for Minimum Hubs.....	45
3.21 - LMDS Frequency Plan with Frequency Reuse of Two.....	46
3.22 - LMDS Connectivity.....	57
3.23 - ATM Protocol Stack.....	59
3.24 - ATM Service Class Associations with Service Layer.....	61

4.1 - Virginia Tech BTA's.....	64
4.2 - Deployment Strategy Block Diagram.....	66
4.3 - South Boston: Primary and Secondary Customer.....	68
4.4- Net.Work.Virginia Connectivity.....	70
4.5 - Net.Work Virginia Service Sites.....	70
4.6 - South Boston Digital Elevation Map (DEM)	71
4.7 - Longwood College Continuing Education Center (CEC).....	76
4.8 - Taylor Building Smoke Stack.....	77
4.9 - Riverstone Business Park.....	78
4.10 - Tower on Southside of Rt. 58 (American Tower Corp.).....	79
4.11 - PMP Hub site.....	80
4.12 - 3-30 Degree Sector (American Tower Corporation)	82
4.13 - 2- 45 Degree Sector (American Tower Corporation)	83
4.14 - 1-90 Degree Sector (American Tower Corporation)	84
4.15 - LOS Validation from Tower to Riverstone.....	85
4.16 - LOS Validation from Tower to CEC.....	85

4.17 - LOS Validation from Tower to AXA.....	86
4.18 - Mesh Network Proposed Layout.....	87
4.19 - LOS Validation from CEC/TNCP to MIP.....	88
4.20 - LOS Validation from MIP to ABB.....	88
4.21 - LOS Validation from ABB to Dscan.....	88
4.22 - LOS Validation from Dscan to Riverstone.....	88
4.23 - LOS Validation from MIP to Riverstone.....	88
4.24 - LOS Validation from MIP to AXA (No LOS)	89
4.25 - LOS Validation from AXA to Riverstone.....	89
5.1 - NPV Distribution for South Boston.....	98
5.2 - Life Cycle Probability for the LMDS System in South Boston.....	99

List of Tables

2.1 Capacity Comparison of Available Access Technologies.....	5
2.2 LMDS Advantage/Disadvantages.....	6
2.3 Applications of LMDS.....	7
2.4 Bandwidth Allocation.....	8
3.1 Diffraction Loss Model for a 90° Building Corner.....	22
3.2 Rain Attenuation Calculation: Virginia Tech.....	24
3.3 Rain rate for Specific Rain Zones (mm/hr).....	25
3.4 Coefficient Values for Estimating Specific Attenuation Equation.....	25
3.5 Clear Weather Link Budget for a Digital Radio Link.....	53
3.6 OSI Network Layers.....	58
3.7 ATM Service Classes.....	60
4.1 Link Budget A: PMP Longest Link- Hub to AXA.....	90
4.2 Link Budget B: Mesh Network.....	91

Chapter 1

Introduction

1.1 Background

With the recent explosion in the development of wireless technology, it is no surprise that the next frontier in this evolution will be to provide broadband wireless services to customers. Recently, researchers have been eagerly exploring possible solutions to the “Last Mile Problem”. With new allocations of bandwidth in the 28GHz frequency range, innovative concepts have been developed to utilize millimeter wave technologies to provide services such as Local Multipoint Distribution Service (LMDS) as a viable solution to this issue. This new development serves as the catalyst for the topic of this thesis, to provide an overview of the factors affecting the strategies involved in the deployment of a LMDS system.

1.2 Document Overview

In this thesis we will examine various issues surrounding the deployment of an LMDS network. The reader will become familiar with the concepts and the technical background involved in a LMDS broadband wireless system. The thesis will present an overview of various deployment strategies. We will further demonstrate the application of the deployment techniques described in this thesis on an actual proposed deployment in a rural commercial environment. It is with this structure in mind that the thesis is written.

In Chapter 2, readers will have the opportunity to familiarize themselves with an overview of LMDS technology. After providing the necessary technical background, explanations of the strategies/methodologies involved in the system deployment will be

explored in Chapter 3. With an understanding of the various considerations involved in a deployment, we will next examine an implementation of LMDS for a commercial environment using the suggested techniques described in the thesis. In order to cover the full scope of the steps taken to deploy a system, this paper will also provides a summary of the business strategies involved in the deployment.

Chapter 2

Overview of LMDS

Through this section, the reader will be exposed to the technology and the evaluation of LMDS systems. In order to develop an understanding of what is LMDS (Local Multipoint Distribution Service), one must first decipher the definition to the acronym. The following provides a clear description:

- **L** (local) - denotes that propagation characteristics of signals in this frequency range limit the potential coverage area; ongoing field trials conducted in metropolitan centers place the range of an LMDS transmitter at up to 5 miles.
- **M** (multipoint) - indicates that signals are transmitted in a point-to-multipoint or "broadcast" method; the wireless return path, from subscriber to the base station, is a point-to-point transmission.
- **D** (distribution) - refers to the distribution of signals, which may consist of simultaneous voice, data, Internet, and video traffic.
- **S** (service) - implies the "subscriber" nature of the relationship between the operator and the customer; the services offered through an LMDS network are entirely dependent on the operator's choice of business.

LMDS, or sometimes called LMCS (Local Multipoint Communications Systems), offers an exciting new alternative to traditional means of providing voice, data or video service to consumers over copper telephone wires or coax cable. This use of fixed wireless technology eliminates the expensive task of installing communication lines to each user, and can also be

deployed in a relatively short amount of time. With multi-service (Multipoint) capabilities and large bandwidth capacity, LMDS addresses the present and future needs of the customer. Hence, this technology is considered as one of the most prominent solutions to the "Last Mile Problem" of extending communication to homes and businesses.

The last mile problem extends from the interface between the large network backbones made up of high-speed fiber optic cables (*Gbps* capacity) with that of the "local loop" transition copper cables (*kpbs* modem lines) connected to homes and local businesses. In order to resolve this restriction in capacity, broadband wireless networks capable of handling capacities ranging into hundreds of Mbps, such as LMDS, was developed. There are four main components in the basic architecture of an LMDS system: network operations center (NOC), fiber-based infrastructure, base station, and customer premise equipment (CPE). The following figure (Figure 2.1) provides a pictorial illustration of this network.

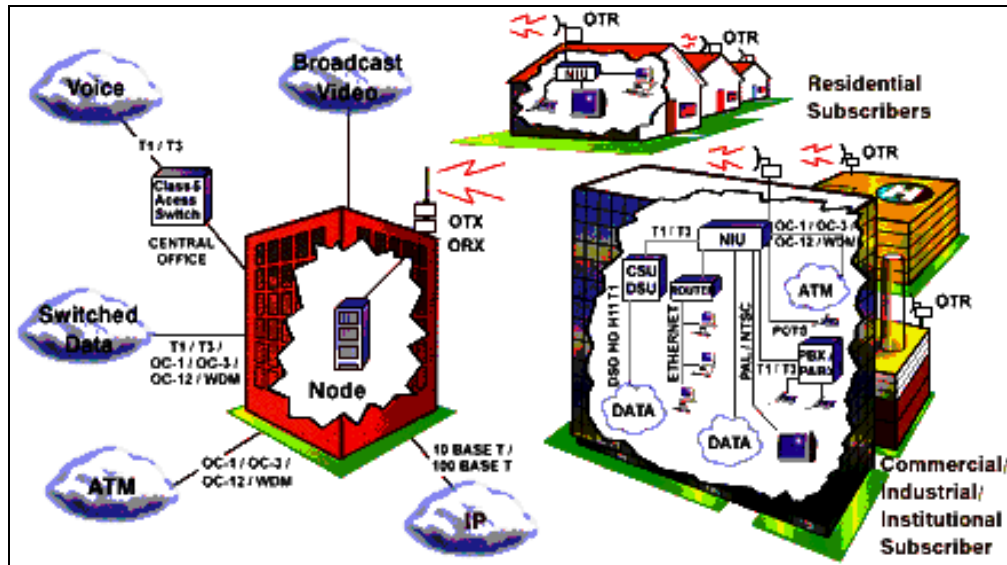

Figure 2.1 - Illustration of an LMDS network [36]

The NOC is the control center of the LMDS service provider, which monitors the performance of the network. At the base station, the connection and conversion from wireless to the fiber-based infrastructure is established. This includes connections to Internet and public switch telephone networks (PSTN). The Customer Premise Equipment (CPE) is the

customer's interface with the subscribed network. As demonstrated in the figure, this interface can be shared with many users or a single user [1].

Due to the propagation characteristics of signals in this frequency range, an LMDS system often uses cellular-like network architecture, though services provided are fixed, not mobile. Propagation at microwave frequencies has been then the subject of much research. For LMDS, whose operation frequency is in the 28 GHz (Ka-Band) range, fading due to vegetation, rain, and obstruction effects has a large impact on its overall performance, limiting its effective range to around 5 km. These issues will be examined more closely in Chapter 3.

2.1 Advantages/Disadvantages of LMDS

As described earlier, LMDS provides a wireless alternative to other wired and wireless applications such as DSL, fiber, coax, or satellite. The different technologies contributing to broadband access networking all have clear advantages and drawbacks. Illustrated in Table 2.1, is the capacity comparison of several access technologies to each remote. [1]

Table 2.1 Capacity comparison of available access technologies [1]

Type	Uplink data rate	Downlink data rate	Max range (km)
Analog modem	14.4~56 Kbps	14.4~56 Kbps	< 6~7
ISDN	128 Kbps	128 Kbps	N/A
ADSL	64 Kbps ~ 1.5 Mbps	1.5 ~ 9 Mbps	2~6
VDSL	> 10 Mbps	13 Mbps 25 Mbps	1
Cable Modems	500 Kbps~3 Mbps	30 Mbps (shared)	N/A
Satellite, DVB-RCS	2 Mbps	36 Mbps (shared)	Not limited
LMDS	0~8 Mbps typical 25 Mbps possible	45 Mbps (shared)	5

In this section, we will mainly concentrate on the tradeoffs in an LMDS system. As described earlier, LMDS operates at millimeter wave frequencies (28GHz). This provided the opportunity for the governing bodies such as the FCC to allocate greater bandwidths to the potential service providers. With larger bandwidths, providers will be able to make available services such as video and higher data transmissions that would not have been possible in the past, as illustrated in Table 2.1. While operating at such high frequencies provides definite improvements are made over current systems, it is not without its own drawbacks.

One of the major disadvantages of operating at LMDS frequencies is susceptibility to attenuation due to the requirement of Line of Sight (LOS). At 28 GHz, losses due to rain, foliage, and obstructions play a significant role in the deployment strategies. Along with attenuation due to terrestrial issues, the total distance of coverage is also limited by usage of a high frequency. Again, these issues will be further explained in the later chapters. The following is a summary describing both advantages and disadvantages of an LMDS system:

Table 2.2 LMDS Advantage/Disadvantages

LMDS Advantages	LMDS Disadvantages
<ul style="list-style-type: none"> • Low entry and deployment cost 	<ul style="list-style-type: none"> • Operating in millimeter wavelengths-requiring line-of-sight to transmitter
<ul style="list-style-type: none"> • Ease and speed of deployment 	<ul style="list-style-type: none"> • Attenuation effects due to rain, foliage, and obstructions
<ul style="list-style-type: none"> • Point-to-Multipoint access- Provides a solution to the Last Mile Problem 	<ul style="list-style-type: none"> • New, un-established, lack of standards
<ul style="list-style-type: none"> • Provides high capacity (broadband) service 	<ul style="list-style-type: none"> • Equipment is still in its early development stage- equipment cost remains quite high
<ul style="list-style-type: none"> • Scalability- Ability to grow-out footprint coverage with demand 	

[32][33]

With the demand for greater bandwidth and faster data rates, it is of no surprise that technology such as LMDS presents an exciting proposition to the solution. The success of this system could change the way mass media and the Internet is accessed.

2.2 Applications of LMDS

The following is just a quick summary of potential services over LMDS:

Table 2.3 Applications of LMDS [31]

Broadband Services	Downlink Bandwidth	Uplink Bandwidth
Broadcast, multicast; Pay-per-view Digital TV/ channel	1.5~6 Mbps	14.4 ~ 64 Kbps
Interactive Services: Interactive video Interactive games Home shopping Telemedicine	64 Kbps~6 Mbps	14.4 ~ 128 Kbps
Internet access: Internet browsing Software download Electronic banking	14.4 Kbps~10 Mbps	14.4 ~ 128 Kbps
Symmetric Service: Work at home Videoconferences Voice telephony	14.4 Kbps~3 Mbps	14.4 Kbps ~ 2 Mbps
Small business/home: Internet homepage Internet server Internet download	14.4Kbps ~ 1.5 Mbps	14.4 Kbps ~ 1.5 Mbps
Others: Fax, e-mail, file transfer	14.4 ~ 64 Kbps	14.4 ~ 64 Kbps

2.3 Bandwidth Allocation

There are many organizations, such as the International Telecommunications Union (ITU) and DAVIC (Digital Audio Visual Council), who are assisting the coordination of standards for various technologies. The ITU helps to coordinate global telecommunication issues such as spectrum allocation, which is then licensed internally within a country by a governing group such as the FCC [1]. LMDS occupies a broad expanse of spectrum; one license for a bandwidth of 1150 MHz at (27~31GHz)-“Block A” and another allocation for 150 MHz at (31~31.3GHz)-“Block B” [37].

Table 2.4 Bandwidth Allocation [31]

License block	Spectrum band	Potential applications
License A (1,150Mhz)	(A-1) 27.5-28.35 GHz	License A is for asymmetric/symmetric services. (A-2) is limited to Base Station to subscriber transmission. (A-2) and (A-3) are for symmetric services.
	(A-2) 29.10-29.25 GHz	
	(A-3) 31.075-31.225 GHz	
License B (150 MHz)	(B-1) 31.000-31.075 GHz	Small business application
	(B-2) 31.225-31.300 GHz	

2.4 System Specifications

Local Multipoint Distribution Service (LMDS) is a broadband wireless network that can provide approximately 1 GHz of bandwidth in the 28 GHz band. Depending on the operator’s service, the network equipment can be configured to provide video, voice, and data services to its customers. Currently, ATM and IP switching are the leading standard in which these services will be delivered. The following section provides an overview of two competing deployment architectures: PMP and Mesh networks.

2.4.1 PMP (Point-To-Multipoint)

Overview

The system is setup with a resemblance to that of a fixed cellular network. Service is provided through a central Base Station/Hub and the remotely located recipients of these services are called Remotes/CPE (Customer Premise Equipment). Described below are the interfaces of an LMDS system:

- Main Hub IDU (Indoor unit) will connect with the landline WAN backbone (DS1, OC3-c, etc...), as well as connections to the Internet and PSTN (Public Switched Telephone Network).
- Total capacity per sector will be based on the modulation technique (QPSK, 16-QAM, 64-QAM) and multiple access schemes (TDMA, FDMA) that are chosen.
- The allocated bandwidth is then divided to provide various capacities per sector with sector sizes (15, 22.5, 30, 45, 60, 90°).
- Remote outdoor units are arranged so that LOS (line-of-sight) is achieved with the hub, usually no further than approximately 6 km, due to degradation in signal strength.
- Based on the bandwidth/channel and modulation technique chosen, each remote indoor unit will provide a certain level of service (T1/E1, Fractional T1/E1, Ethernet, analog voice, NxT1/E1 Frame Relay).
- The CPE (Customer Premise Equipment) IDU remote unit will then allow interfaces and a choice of services (10baseT-ethernet, ATM-25, MPEG-2, etc...) to the end users.

The following pictures provide a general description of the connectivity between the backbone infrastructure to the customer premise units. The air links represented are just examples of the types of technology or connectivity.

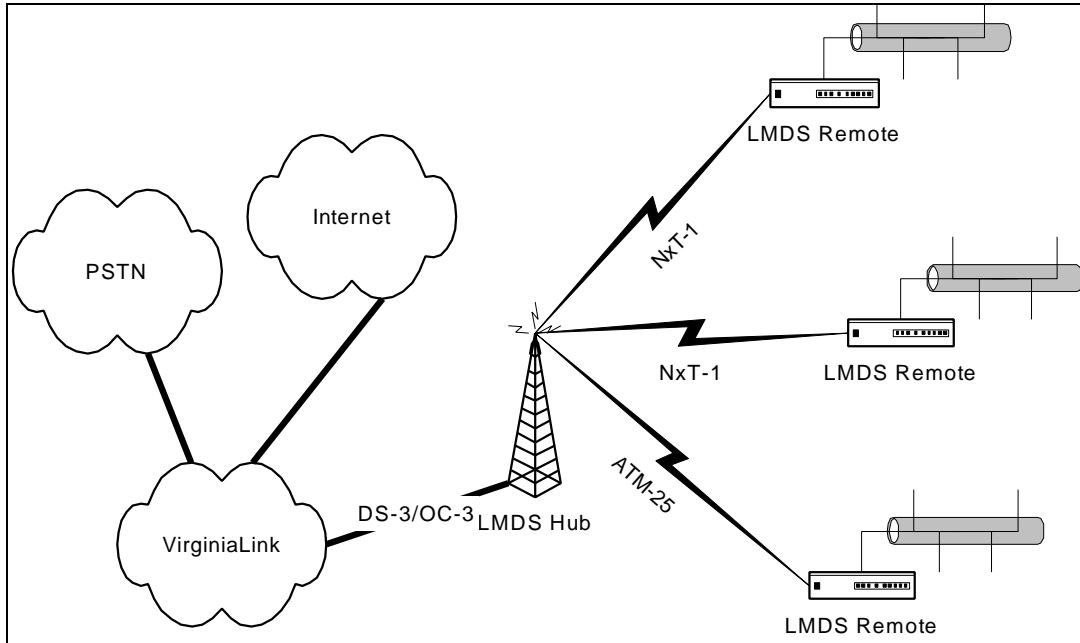

Figure 2.2 - PMP LMDS layout

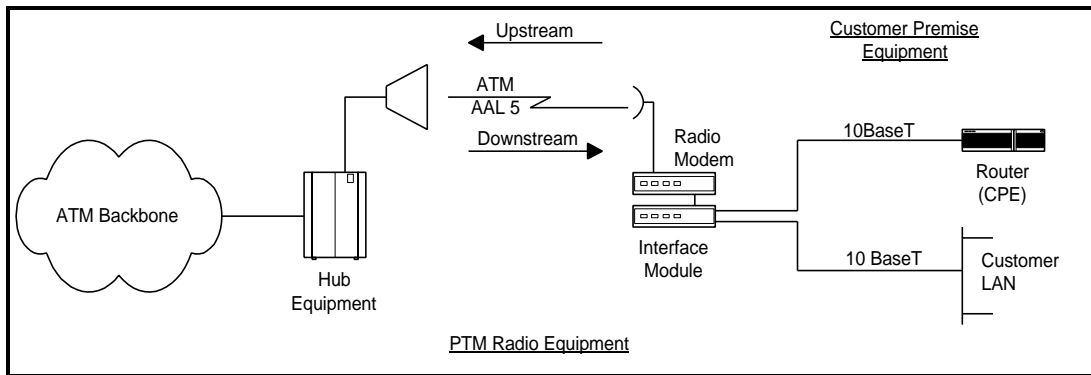

Figure 2.3 - Ethernet Application

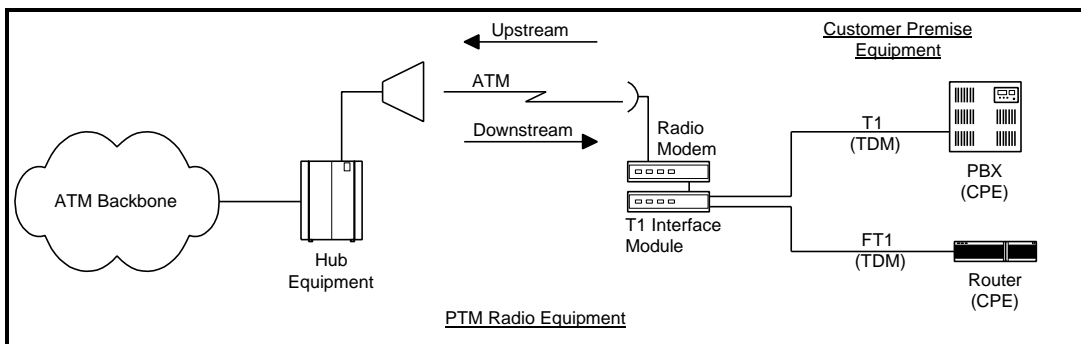

Figure 2.4 - T1 Application

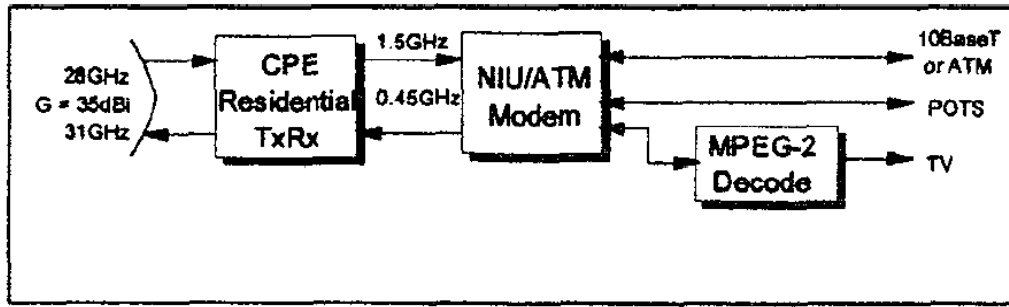

Figure 2.5 - CPE/Remote Unit

System Components

The following represent typical equipment requirements at the hub/base station and remotes/CPE (Customer Premise Equipment):

1. Hub/Base station

IDU (Indoor Unit)

- Basic Rack mount chassis with IDU power supplies
- Modulators
- Demodulators (FDMA network)
- Burst Demodulators (TDMA network)
- Sector ATM Controllers (SAC)
- ODU Multiplexers
- ODU Power Supply Chassis
- OC-3 Redundant Switch Chassis
- Outdoor Units (ODUs) containing the RF components mounted directly on the antenna
- An Inter-facility Link (IFL) consisting of one coaxial cable connecting the sector chassis to the ODU.

ODU (Outdoor Unit)

- Sector antenna
- RF Electronics
- ODU Enclosure
- Mount

2. Remote

IDU

- An Indoor Unit (IDU) containing a modem and a Remote ATM Controller (RAC) with four UTP-5 ports for connection to one or more ATM Service Modules
- One or more ATM Service modules connected to the UTP-5 ports to provide T1/E1 Frame Relay, T1/E1 Circuit Emulation, Ethernet 10BaseT
- An Interfacility Link (IFL) consisting of a single coaxial cable
- A modem that provides the physical layer wireless communication link between the Remote Terminal and the Sector Terminal
- A remote ATM Controller (RAC) that is responsible for control and monitoring local functions and processing Network Management messages from the base station to the Network Operations Center
- AC or DC input power supply

ODU

- Reflector
- Feed
- Radome
- ODU Enclosure
- RF Electronics
- Outdoor Mount
- An Outdoor Unit (ODU) containing the RF electronics and the antenna

2.4.1 Mesh

The Mesh architecture was designed to overcome possible LOS problems from the Hub to Remotes that could be experienced by a conventional Point-to-Multipoint architecture. The Mesh system does not employ the use of base stations or “hubs”. Only one type of hardware is employed (a node) located at the customer’s premises. Each node is connected by up to four narrow point-to-point radio links to other nodes and each node can transit data received to other nodes as well as terminate data for the local user [35].

Each link will have a maximum range of up to 2 km depending on the modulation technique and link attenuations, with beamwidths of approximately 4.5° in azimuth and 9° in elevation. This system is capable of delivering total variable bit rate traffic of up to 25 Mbps duplexed. While at the individual customer nodes, a connectivity rate of 4~6 Mbps is achieved. The traffic is provided across an ATM routing network offering full or fractional E1/T1 services and IP over ATM (via an Ethernet 10-BaseT interface).

The resultant combination of links and nodes is referred to as a mesh; a hypothetical example is illustrated in Fig 2.6. Each of the four antennas on a node is automatically steerable by a stepping motor, allowing the mesh system to be adapted on demand by the management system. This architecture affords greater potential to provide connections to customers since the requirement of line of sight to a hub is removed. Instead, a potential customer only requires line-of-sight to any other customer, to be connected to the mesh. This potentially allows higher levels of customer penetration to be achieved.

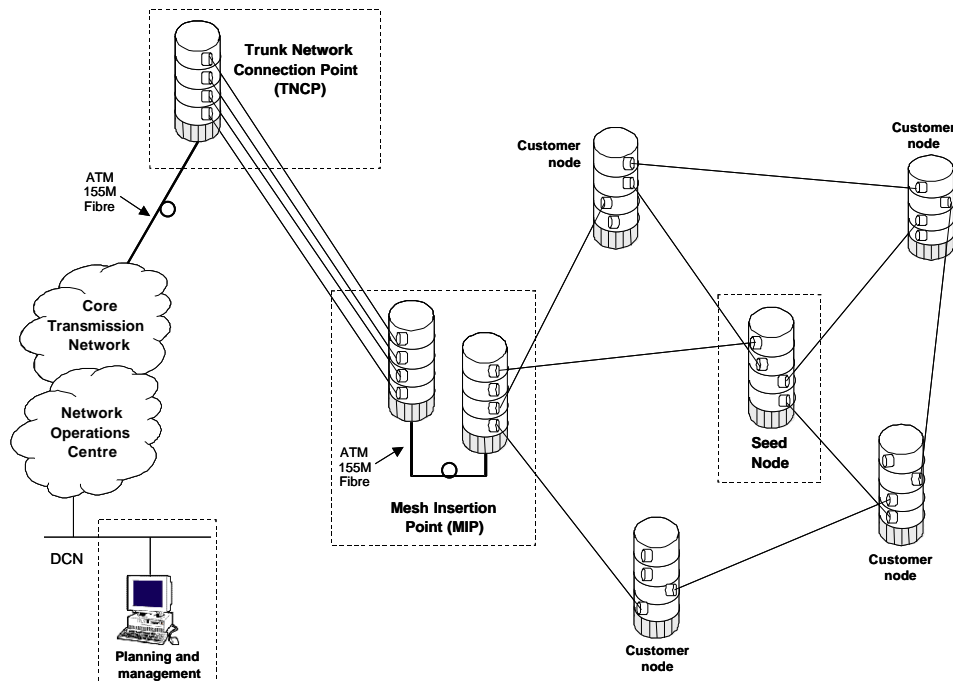

Figure 2.6- Mesh Network [34]

System Components

1. TNCP

Data is transferred from the WAN/trunk network (OC-3c or DS-3) into the access network at the Trunk Network Connection Points (TNCPs). The location of these points will be strongly determined by the route followed by the trunk cables/fibers of the network to which connection is to be made. TNCPs will typically handle data rates greater than that of any individual Mesh Insertion Point (MIP), so that typically three or four MIPs may be served by each TNCP.

2. MIP

Mesh Insertion Points (MIPs) comprise the standard subscriber node equipment for connection to other subscribers and additional separate node equipment providing a link to one of the TNCPs. The distribution of MIPs will be intended to balance the traffic flow across the predicted future mesh, so that local bottlenecks do not limit the performance of the mesh. MIPs can also support customer connections; so they therefore, can be considered to be the very first customers on the Mesh, as MIPs have to be installed before any other customer mesh nodes. (The selection of good MIP sites is an iterative process).

3. SN

Seed Nodes are similar to standard subscriber node installations, but placed by the operator at non-subscriber locations. Their purpose is simply to extend coverage to a larger number of potential subscribers than would otherwise be within view of the mesh (or initially, just the MIPs). They therefore act only as transit nodes (repeaters), and not as either sources or sinks of network traffic. Their major characteristics are listed below:

- Seed sites are identified, acquired and prepared in advance of rollout, although actual installation of seed nodes may not occur at this time.
- Seed nodes are specifically selected for high visibility, so that a small number of seeds confer "Day One connectability" on the maximum number of potential subscribers.

- An essential part of the installation of a seed is to establish a path back to an MIP (possibly via other installed seeds). It is therefore a requirement that every seed site should have at least one line of sight either directly to an MIP or indirectly via another seed site. The result of the seeding process is a seed network comprising a single connected mesh.

4. CN

Customer Nodes, installed at the customer premises, provide both transit traffic for other customer nodes, and service for the subscriber directly connected at that site. The customer has a radio unit outdoors (the ODU) and a service presentation indoor unit (the IDU). It is at this point that the customers gain either Ethernet or T1 connectability.

Chapter 3

System Deployment strategy

The topic of LMDS system deployment is one in which no best formulation has been truly identified. Because LMDS is still in its infancy stage, many developers and manufactures are still looking for systematic ways to optimally deploy a network. It is the intent of this chapter to provide a methodical deployment technique by examining all aspects that will influence the deployment strategy.

The goal of all design engineers is to provide a high-speed network service that surpasses what the potential customers are currently receiving. Of course, the design must offer the required service at a cost that is competitive to a wired network. It will be evident in the deployment example discussed in Chapter 4 that a close working relationship must be formed with the GIS (Geographic Information Systems) and financial analysts. In order to produce the most efficient and cost effective solution, the initial design proposals will be cycled through each group repeatedly for evaluation and optimization.

In terms of the technical aspects, we will examine various design configurations and issues that affect the performance of each system. At this stage, the manufacturers are striving to differentiate themselves with distinctive feature sets, air interfaces and levels of standards support. Despite basic similarities among the products of most manufacturers, no standards for interoperability are in place, nor are they likely to appear for some time as long as the standards-setting process takes its normally slow course. The Institute of Electrical and Electronics Engineers (IEEE) has sponsored meetings among various manufacturers, but these are at a very preliminary stage. Currently, there are three types of LMDS system architecture that have emerged from the new breed of high frequency equipment manufacturers, the Point-to-Point (PTP), Point-to-Multipoint (PMP), and the Mesh design. In this thesis, we will

concentrate on the latter two designs for their capabilities to provide a larger coverage area and customers. The following is the flow chart that describes the engineering design process determined through this research:

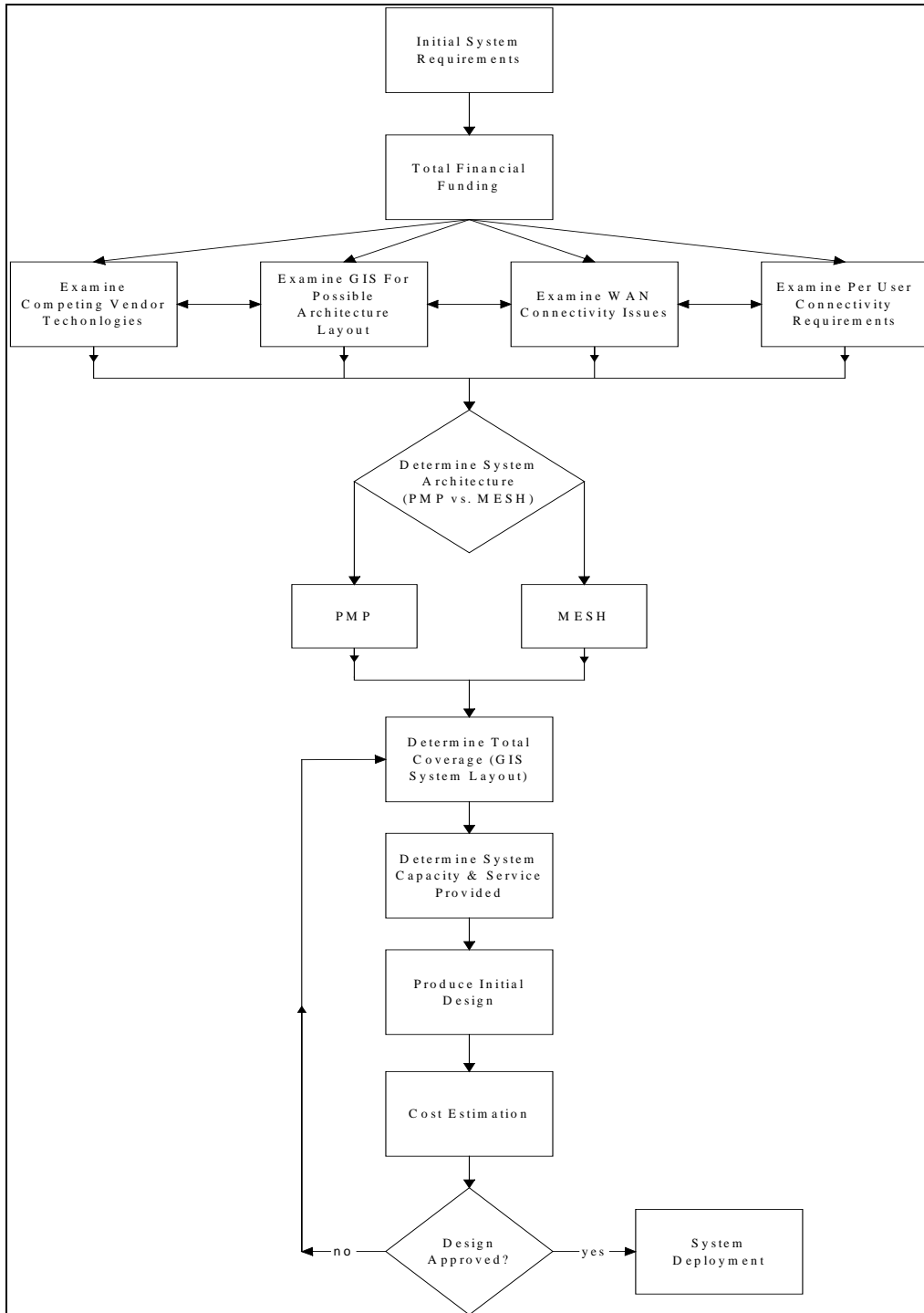

Figure 3.1- Deployment Strategy Block Diagram

3.1 Terrestrial issues

When considering the deployment of any wireless network, it is important to examine the terrestrial effects that might impact the system's operations. The propagation properties of radio links will vary depending on the frequency of operation and the environment in which they are operating. At LMDS frequencies (28 GHz), attenuation due to obstructions, rain, and foliage plays a major role in determining the amount of coverage that the system will be able to provide. One of the major applications for an outdoor millimeter-wave system is fixed point-to-point/multipoint broadband communications that requires Line-of-Sight (LOS). In the following sub-sections, we will briefly examine the terrestrial attenuation issues that surround the propagation of millimeter-waves.

3.1.1 Obstruction

Unlike multipath fading that affects operation at lower frequencies, an LMDS system that transmits at 28 GHz will not experience as much shadowing and reflection effects due to its dependency on LOS and the relative short distances of coverage (2~6km) [1]. At millimeter wavelengths, the antennas used are highly directional (2~5 degree vertical coverage), thus reducing the effects of multipath. However, it is also the requirement for LOS and environmental attenuations that hinders the total coverage capabilities of this network.

When the radio link does experience attenuation due to physical obstructions such as terrain and buildings, it is often referred to as diffraction and/or scattering loss. Diffraction is the apparent bending of radio waves around building corners, roof peaks, and other edges or boundaries. This "bending" of the radio waves allows a signal to penetrate short distances into shadow regions. An obstacle that does not block the line-of-sight (LOS) path can still diffract a signal. The phenomenon of diffraction can be explained by Huygen's principle. Huygen's principle states that all points on a wavefront can be considered as point sources for the production of secondary wavelets, and that these wavelets combine to produce a new

wavefront in the direction of propagation [3]. Figure 3.2 provides an illustration of the concept behind Knife-Edge diffraction and Huygen's principle.

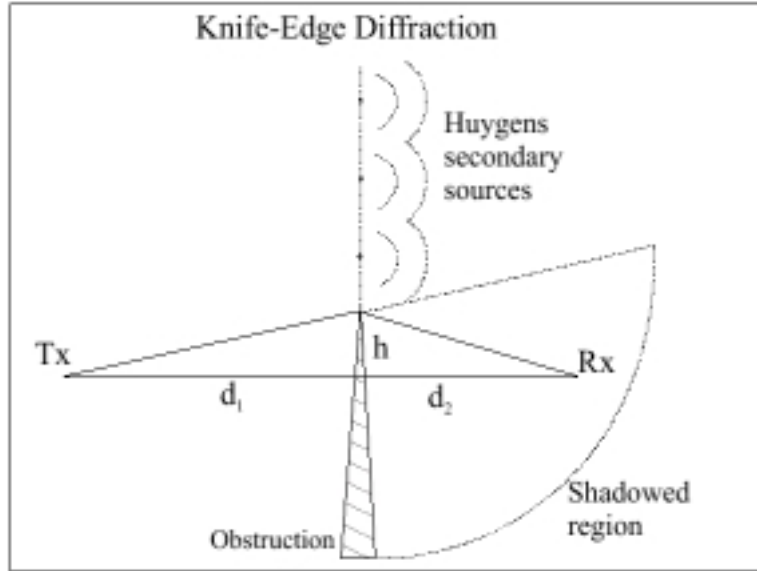

Figure 3.2 - Knife-Edge Diffraction

For LMDS point-to-point/multipoint links, not only is LOS path clearance required, but Fresnel Zone clearance is also highly desirable in order to avoid diffraction loss. The method applied to the calculating attenuation due to diffraction is called the Knife-edge diffraction model. The field strength at Rx is a vector sum of the fields generated by the secondary Huygen's sources in the plane above the knife-edge. The electric field strength, E_d , of a knife-edge diffracted wave is given by:

$$\frac{E_d}{E_0} = F(v) = \frac{(1+j)}{2} \int_v^{\infty} \exp(-j\pi t^2/2) dt \quad (3.1)$$

where E_0 is the free space field strength in the absence of both the ground and knife edge, $F(v)$ is the complex Fresnel integral, and v is the Fresnel-Kirchoff diffraction parameter given by equation (3.2).

$$v = h \sqrt{\frac{2(d_1 + d_2)}{\lambda d_1 d_2}} \quad (3.2)$$

(Note: obstruction height h can also be negative if it falls beneath the LOS path)

The diffraction gain due to the presence of a knife-edge, as compared to the free space E-field is given by equation (3.3).

$$G_d(dB) = 20 \log |F(v)| \quad (3.3)$$

The following numerical and graphical approximations of equation (3.3) based on the Fresnel-Kirchoff diffraction parameter is often used in practice [4]:

$$G_d(dB) = 0 \quad v \leq -1 \quad (3.4.1)$$

$$G_d(dB) = 20 \log(0.5 - 0.62v) \quad -1 \leq v \leq 0 \quad (3.4.2)$$

$$G_d(dB) = 20 \log(0.5 \exp(-0.95v)) \quad 0 \leq v \leq 1 \quad (3.4.3)$$

$$G_d(dB) = 20 \log\left(0.4 - \sqrt{0.1184 - (0.38 - 0.1v)^2}\right) \quad 1 \leq v \leq 2.4 \quad (3.4.4)$$

$$G_d(dB) = 20 \log\left(\frac{0.225}{v}\right) \quad v > 2.4 \quad (3.4.5)$$

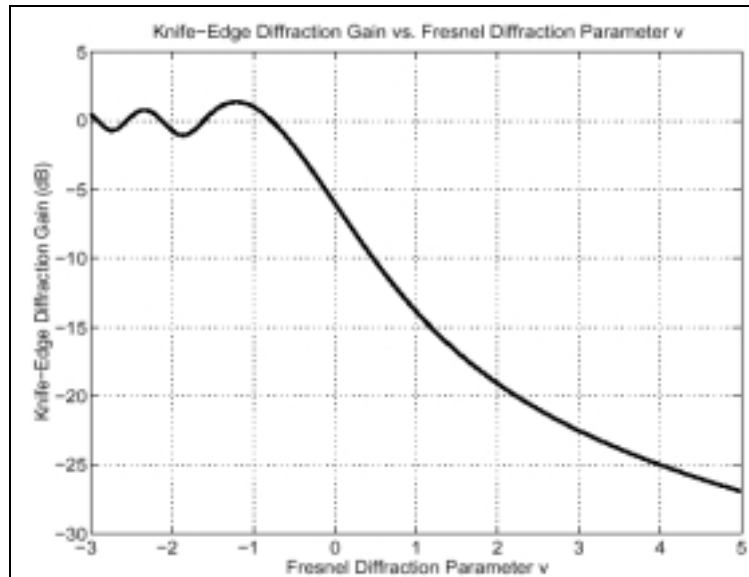

Figure 3.3 - Knife-edge diffraction gain as a function of Fresnel diffraction parameter v

The goal of an LMDS design engineer is to avoid the diffraction effects mentioned above by providing adequate path clearance, this is known as the Fresnel theory. The first Fresnel Zone is a cigar-shaped volume that surrounds the LOS path between the transmitting and receiving antennas. Its radius is represented by the symbol r_1 . Objects outside the first Fresnel zone can normally be ignored. Objects within r_1 of the LOS path can cause diffraction. The value of r_1 is a good measure of how much clearance an LOS path needs in all directions. The first Fresnel zone r_1 , is calculated from the frequency f (GHz), the distance from the obstruction to the transmitting antenna d_1 (km), the distance from the obstruction to the receiving antenna d_2 (km), and the total path length (d_1+d_2) [5]. In Figure 3.2, each concentric circle corresponds to a Fresnel Zone, r_1 being the first of the Fresnel Zones.

$$r_1 = 17.3 \sqrt{\frac{d_1 d_2}{f(d_1 + d_2)}} \text{ Meter} \quad (3.5)$$

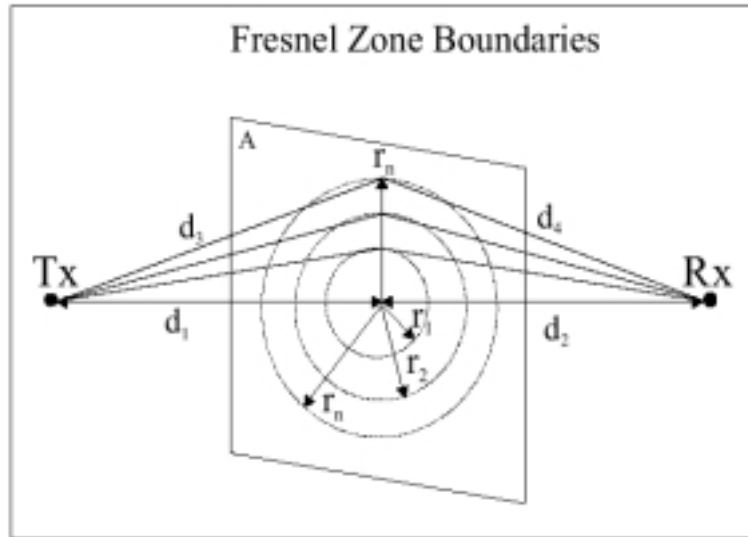

Figure 3.4 - Fresnel Zones

Through a recent study performed at Virginia Tech, an estimation model has been produced for diffraction around buildings at millimeterwave frequencies. Table 3.1 provides a numerical estimation to diffraction losses around a 90° corner of a building. [2]

Table 3.1 Diffraction Loss Model for a 90° building corner

Diffraction Angle (degrees)	Diffraction loss (dB)
$0^\circ \geq \theta_d > 0.1^\circ$	6.5
$0.1^\circ \geq \theta_d > 5^\circ$	$5 \ln \theta_d + 18$
$5^\circ \geq \theta_d \geq 40^\circ$	$0.74 \theta_d + 25$

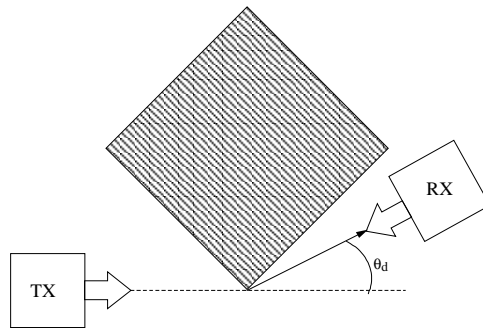

Figure 3.5- Diffraction Model for a 90° Building

3.1.2 Rain effects

The effects of rain can generally be neglected for wireless applications operating at frequencies less than 10GHz. However, attenuation due to rainfall is one of the principal factors affecting path loss at LMDS frequencies. The Exceedance is a performance metric of the radio link relative to rain attenuation. An Exceedance of 0.01% characterizes the link being unavailable for 0.01% of the time (52.56minutes/year) and available for 99.99% of the time. The radio link must be designed to overcome the rain attenuation, therefore meeting the exceedance metric. The unit of the measured rain is in terms of mm/hr. For LMDS frequencies, long periods of light rain effect the link availability much less than severe rainfall that lasts for 10-20 minutes. Table 3.3 provides the median cumulative distribution of rain rate for the rain climate regions found in Figures 3.6~3.8 [6].

The equation and steps taken for calculating rain attenuation based on the International Telecommunications Union (ITU) model are as follows [7,8,13]:

Rain Attenuation Equation:

Step1: Calculate the “specific attenuation” equation (3.6)

$$A_{dB} = kR^\alpha \quad (3.6)$$

The coefficients k and α are frequency and polarization dependent and are calculated using equation (3.6.1) and (3.6.2). The appropriate frequency and antenna polarization (horizontal, vertical, circular) for the coefficients need to be selected when finding the values for k and α as seen in Table 3.4. The rain rate (R) needs to be chosen for the appropriate exceedance; in this case we start with 0.01%, and the desired geographical region.

$$k = [k_H + k_V + (k_H - k_V) \cos^2 \theta \cos 2\tau] / 2 \quad (3.6.1)$$

$$\alpha = [k_H \alpha_H + k_V \alpha_V + (k_H \alpha_H - k_V \alpha_V) \cos^2 \theta \cos 2\tau] / 2k \quad (3.6.2)$$

(θ : path elevation angle, τ : polarization tilt angle)

Step2: Determine the path averaging factor (r) equation (3.7)

$$r = \frac{1}{1 + d/d_0} \quad (3.7)$$

Determine what the path length of the radio link (d) and enter it into equation (3.7). Then find d_0 via equation (3.8,3.9).

$$d_0 = 35e^{-0.015R_{0.01}}; R_{0.01} \leq 100mm / hr \quad (3.8)$$

$$d_0 = 35e^{-0.015 \times 100}; R_{0.01} \geq 100mm / hr \quad (3.9)$$

Step3: Now find the attenuation for a 0.01% exceedance equation (3.10).

$$A_{0.01} = A_{dB / km} \times d \times r \tag{3.10}$$

Step4: Attenuation for other exceedance percentages can be calculated by using equation (3.11).

$$A_p / A_{0.01} = 0.12 \times p^{-(0.546+0.043 \log_{10} p)} \tag{3.11}$$

An example of the calculation from above is presented in Table 3.2 showing the specific attenuation for the Rain Region (K) covering Virginia Tech and the various exceedance rates based on a vertically polarized antenna. ($k=0.14$, $\alpha=1.015$)

Table 3.2 Rain Attenuation Calculation: Virginia Tech

Percent Outage	Percent Available	Minutes/Year Unavailable	Rain Rate (mm/hr)	Attenuation (dB/km)
1%	99.000%	5256 min.	1.5	0.211
0.1%	99.9%	525.6 min.	12	1.743
0.05%	99.95%	262.8 min.	25	3.673
0.01%	99.99%	52.56 min.	42	6.219
0.005%	99.995%	26.28 min.	80	11.960
0.001%	99.999%	5.256 min.	100	15.001

Table 3.3 Rain rate for specific Rain Zones (mm/hr)

Percentage of time (%)	A	B	C	D	E	F	G	H	J	K	L	M	N	P	Q
1.0	<0.1	0.5	0.7	2.1	0.6	1.7	3	2	8	15	2	4	5	12	24
0.3	0.8	2	2.8	4.5	2.4	4.5	7	4	13	42	7	11	15	34	49
0.1	2	3	5	8	6	8	12	10	20	12	15	22	35	65	72
0.03	5	6	9	13	12	15	20	18	28	23	33	40	65	105	96
0.01	8	12	15	19	22	28	30	32	35	42	60	63	95	145	115
0.003	14	21	26	29	41	54	45	55	45	70	105	95	140	200	142
0.001	22	32	42	42	70	78	65	83	55	100	150	120	180	250	170

Table 3.4 Coefficient values for estimating Specific Attenuation Equation

Frequency (GHz)	k_H	k_V	α_H	α_V
1	0.0000387	0.0000352	0.912	0.880
2	0.000154	0.000138	0.963	0.923
4	0.000650	0.000591	1.121	1.075
6	0.00175	0.00155	1.308	1.265
7	0.00301	0.00265	1.332	1.312
8	0.00454	0.00395	1.327	1.310
10	0.0101	0.00887	1.276	1.264
12	0.0188	0.0168	1.217	1.200
15	0.0367	0.0335	1.154	1.128
20	0.0751	0.0691	1.099	1.065
25	0.124	0.113	1.061	1.030
30	0.187	0.167	1.021	1.000
35	0.263	0.233	0.979	0.963
40	0.350	0.310	0.939	0.929
45	0.442	0.393	0.903	0.897
50	0.536	0.479	0.873	0.868
60	0.707	0.642	0.826	0.824
70	0.851	0.784	0.793	0.793
80	0.975	0.906	0.769	0.769
90	1.06	0.999	0.753	0.754
100	1.12	1.06	0.743	0.744
120	1.18	1.13	0.731	0.732
150	1.31	1.27	0.710	0.711
200	1.45	1.42	0.689	0.690
300	1.36	1.35	0.688	0.689
400	1.32	1.31	0.683	0.684

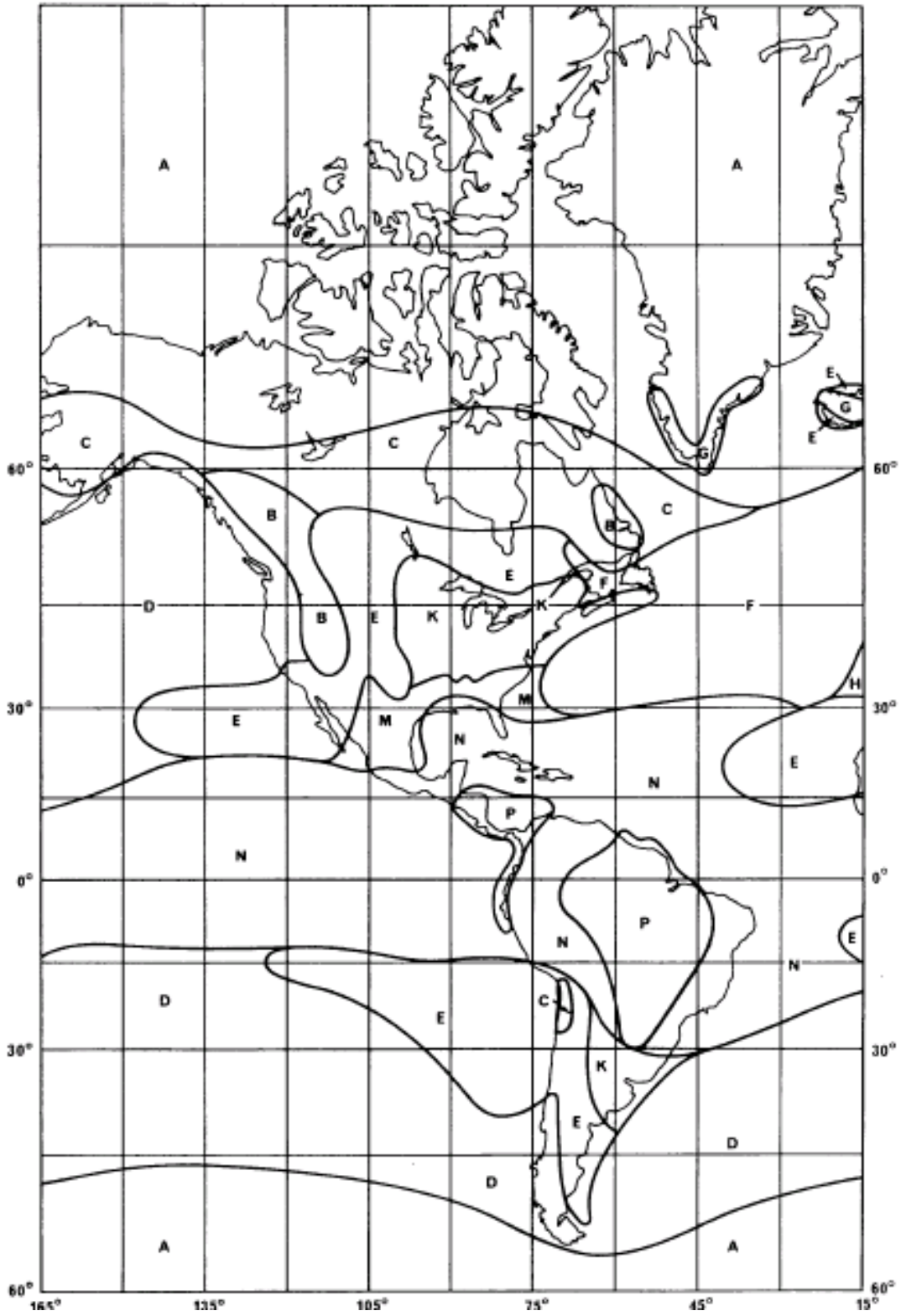

Figure 3.6 - Rain Zone Regions- Americas

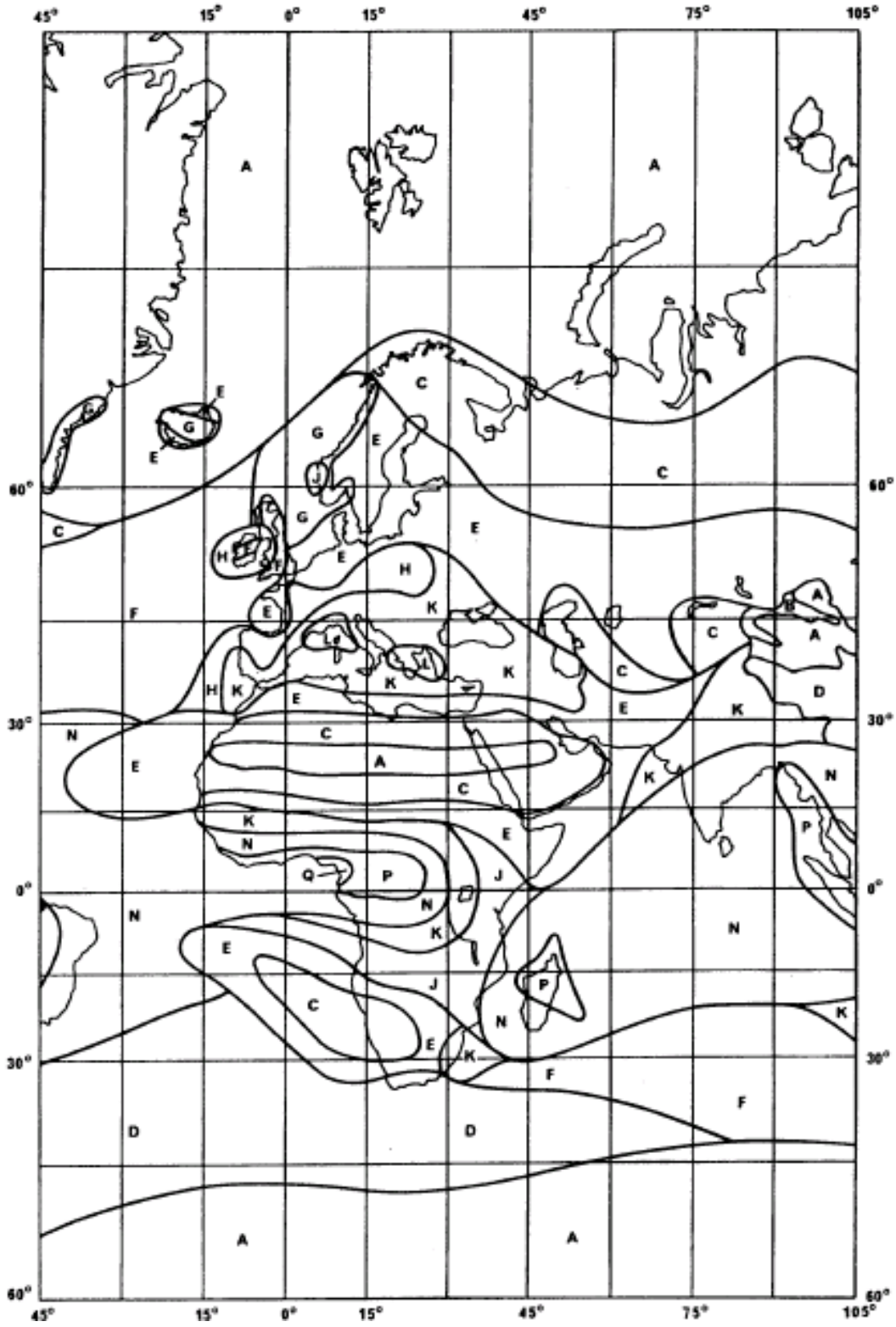

Figure 3.7 - Rain Zone Regions- Europe, Africa

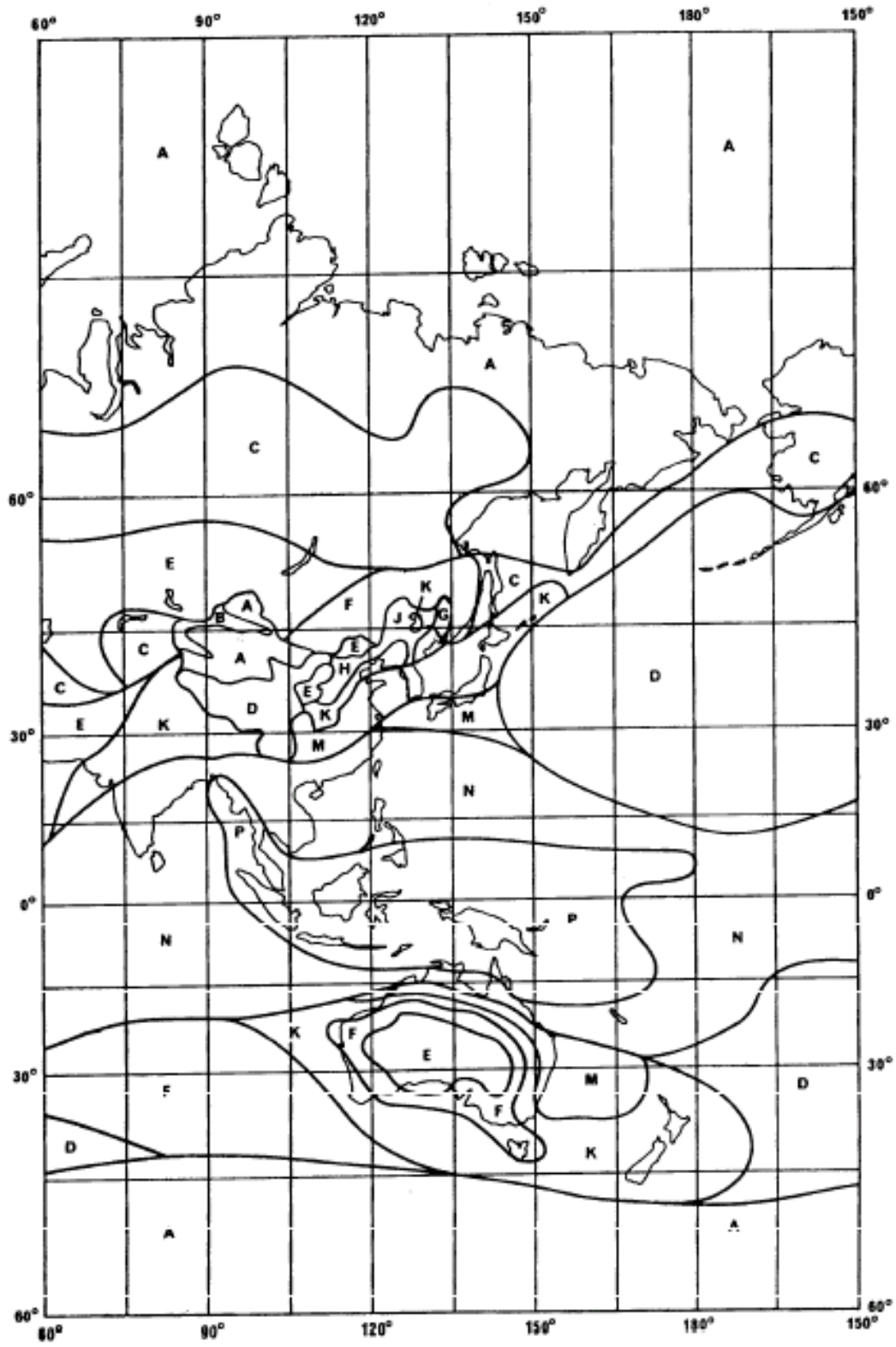

Figure 3.8 - Rain Zone Regions, Asia

3.1.3 Foliage

The effects of attenuation due to vegetation become an important factor at frequencies approaching millimeter wavelengths for point-to-point radio links. At LMDS frequencies, leaves, twigs, branches, and whole trees all have dimensions that are large compared to the wavelength. They also usually contain water, hence resulting in the absorption and scattering of the transmitted waves as they propagate through areas of vegetation. Experimental investigations have revealed that these transmission losses are influenced by parameters such as the dielectric constant, density, physical size, and shape of the vegetation [9].

In this section, we will concentrate on three propagation models that are recommended by the International Telecommunications Union (ITU). Due to the complexity of calculating the varying characteristics of vegetation, the models presented are not expected to predict the exact loss values that a specific path will encounter. As it is found in previous measurement regimes, over shorter vegetation depths, the attenuation increases rapidly, as the signal is attenuated by more and more vegetation. As the vegetation depth increases, however, the gradient becomes shallower, as scattering from tree to tree becomes a mode of propagation for the transmitted signal, which contributes to the received signal and therefore reduces the active attenuation. The models reviewed are the ITU-R [10], Fitted ITU-R (FITU-R) [11], and the Nonzero Gradient (NZG) model [10].

The ITU-R model was developed from measurements carried out mainly at UHF where the transmit and receive terminals are placed such that that majority of the radio path falls within the vegetation medium, assumed to have a maximum depth of 400 meters. The model expressed below in equation (3.12) is stated to be applicable in the frequency range 200MHz to 95GHz [11].

$$A = 0.2 f^{0.3} d^{0.6} (dB) \quad (3.12)$$

The attenuation is in dB, A , at frequency in MHz, f , due to propagation through a vegetation depth in meters, d .

The fitted ITU-R (FITU-R) model attempts to optimize the ITU-R model. It provides a characterization of vegetative attenuation for both the in leaf and out of leaf state of horse chestnut trees (deciduous trees) having a height of 2m; these expressions are shown in equations (3.13~3.14)

$$A = 0.39 f^{0.39} d^{0.25} \text{ (dB) in-leaf state} \quad (3.13)$$

$$A = 0.37 f^{0.18} d^{0.59} \text{ (dB) out of leaf state} \quad (3.14)$$

These equations were generated using a least squared error fit for a data set at the frequencies of 11.2 GHz and 20 GHz in an in leaf and out of leaf state.

While trying to fit the maximum attenuation model to data at other frequencies, researchers have found that a problem exists where their results show a nonzero final attenuation rate. To account for this, a more general three-parameter nonzero gradient (NZG) model based on the maximum attenuation model but with the freedom of an unfixed final slope, was developed [12]. The attenuation A given by (3.15)

$$A = R_{\infty} d + k \left(1 - \exp \left(- \frac{(R_0 - R_{\infty})}{k} d \right) \right) \quad (3.15)$$

where R_0 = initial attenuation rate (in dB/m), R_{∞} = final asymptotic attenuation rate (in dB/m) and k = offset of asymptotic attenuation rate (in dB). Figure 3.9 shows the comparison between the ITU model versus the NZG model for a measured attenuation rate at 11.2 GHz.

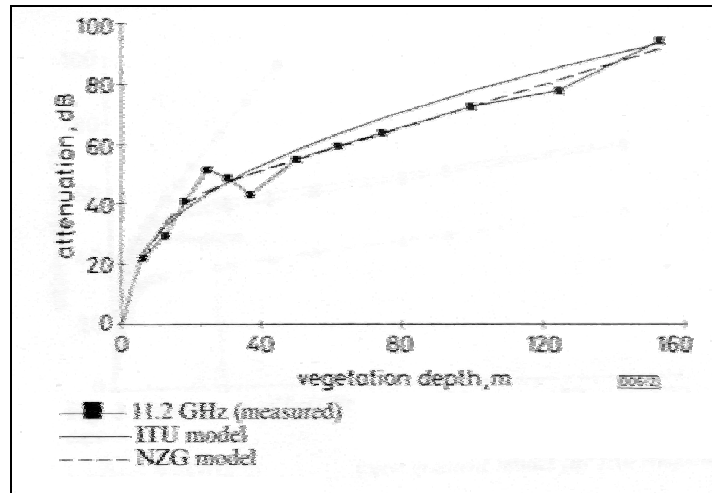

Figure 3.9 - Comparison of measured attenuation rate with nonzero gradient

The conclusion of the research showed that by using the sum of least squared difference between each model and the measured data as a figure of merit, the nonzero gradient model gives an improvement between 17 and 64% when compared with the other two estimation models. However, this study has not investigated the relationship between the parameters of the model and the variables, such as geometry, frequency, and tree type.

3.2 Coverage/Capacity

3.2.1 Multiple Access Techniques

Multiple access schemes allow many wireless users to simultaneously share a finite amount of radio spectrum. The sharing of spectrum is required to achieve high capacity by simultaneously allocating the available bandwidth to multiple users. The two most common access technologies used by LMDS operators and manufacturers are time division multiple access (TDMA) and frequency division multiple access (FDMA).

For TDMA, the system allocates the radio spectrum by time slots, with each slot allowing only one user to either transmit or receive. These time slots are cyclically repeating and so a channel may be thought of as a particular time slot that reoccurs every frame, as seen in Figure 3.10. The features of TDMA include the following [1,3,14,15]:

- TDMA shares a single carrier frequency with several users, where each user makes use of the available time slots. The number of time slots per frame depends on factors such as the modulation technique used and the available bandwidth.
- Data transmission for users in a TDMA system is not continuous, but occurs in bursts.
- Adaptive equalization is usually necessary since the transmission rates are generally very high.
- High synchronization overhead is required because of burst transmissions. Since TDMA transmissions are slotted, this requires the receivers to be synchronized for each data burst. In addition, guard slots are necessary to separate users, and this results in TDMA systems having larger overheads as compared to FDMA.
- TDMA has the ability to supply bandwidth on demand by allocating different numbers of time slots per frame to different users.

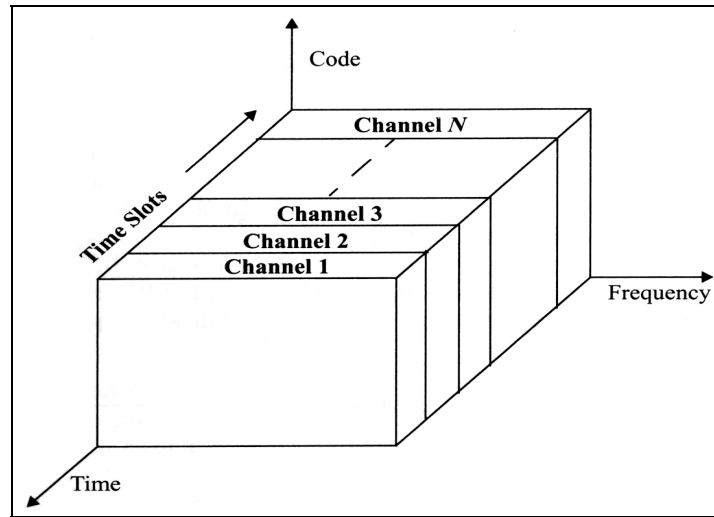

Figure 3.10 - TDMA scheme [3]

With FDMA, the spectrum is divided into separate smaller bands and each user is granted a band, or channel, with which to access the network, as seen in Figure 3.11. These channels can be assigned on demand to users who request service. For the duration of the connection, no other user can share the same frequency band. The features of the FDMA system are as follows [1,3,14,15]:

- The FDMA channel carries only one user at a time.
- FDMA has a higher data rate capacity compared to TDMA systems. Depending on the total number of FDMA carriers used.
- After the assignment of a channel, the link will allow traffic to flow both ways simultaneously and continuously.
- Like time slots, frequency can be dynamically allocated to different users.
- Since it uses a continuous transmission scheme, fewer bits are needed for overhead purposes as compared to TDMA.
- FDMA requires tight RF filtering to minimize adjacent channel interference.
- When traffic is bursty, bandwidth is wasted.

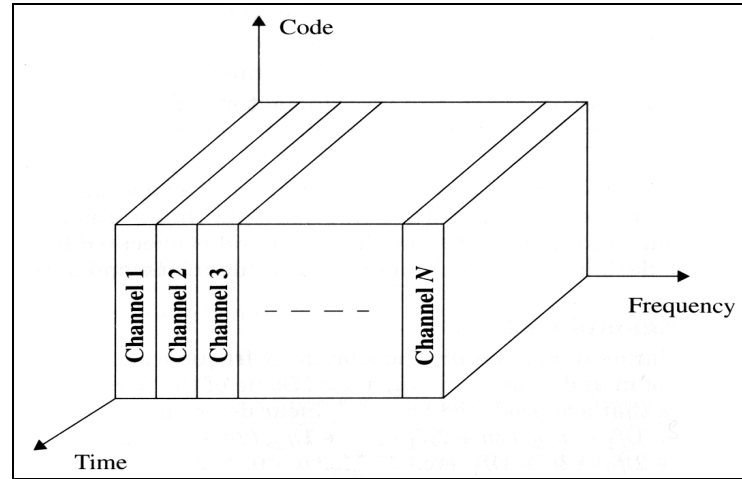

Figure 3.11 - FDMA scheme [3]

Given the background on the two of the more popular access schemes for LMDS systems, it is evident that the task of choosing between TDMA and FDMA is one that requires the examination of many factors. First, it is necessary to estimate the peak and average expected traffic data rate from all of the potential users. Second, it is important to determine which traffic may be multiplexed and traffic which maybe shaped to smooth out its burstiness. Many other aspects such as blocking levels allocated to the wireless link, asymmetrical and symmetrical traffic mixtures, choice of fixed or dynamic allocation, and the link distance all contribute to the decision making process. In general, if the resulting burstiness of the traffic is smooth enough, the upstream traffic requirement can be handled by using FDMA techniques. However, if the traffic remains bursty, TDMA might present a better alternative. This topic will be further examined in Chapter 4, which describes the actual deployment strategy in a rural commercial environment.

3.2.2 Modulation Techniques

Modulation is the process of encoding information from a message source in a manner suitable for transmission. Modulation may be done by varying the amplitude, phase, or frequency of a carrier in accordance with the information in the message signal. The methods often used for broadband wireless LMDS systems are generally separated into phase shift

keying (PSK) and quadrature amplitude modulation (QAM) approaches [16]. Each technique has its advantages and disadvantages, having to do with the number of discrete states the signal can assume and susceptibility to noise and interference. Both options are commonly applied to the access schemes mentioned above.

In PSK modulation, the shape of the wave is modified in phase. The phase can be thought of as a shift in time. In Binary Phase Shift Keying (BPSK), only two phase states will be represented per sine wave cycle starting at either 0 or $\pi/4$ and separated by 180° , while transmitting only one bit per cycle (called symbol). In more complex modulation schemes such as Quadrature Phase Shift Keying (QPSK), more than one bit is transmitted per symbol. However, instead of only two separate phase states, QPSK uses four (e.g., $\pi/4$, $3\pi/4$, $5\pi/4$, $7\pi/4$), carrying two bits per symbol. Like BPSK, QPSK is used because of its robustness. However, since QPSK only modulates two bits per symbol, it still is not very efficient for high-speed communications. Of course, PSK systems can have more phase states than just two, the practical limit being around sixteen.

The QAM technique allows greater efficiency and information density within a given signal bandwidth. QAM (or often thought of as M-ary PSK, QPSK=4-QAM) modulates the signal into discrete levels on a wave cycle by changes in both phase and amplitude. A 16-QAM example is shown in Figure 3.12, where four levels of amplitude are combined with four levels of phase; each unique phase is spaced equally in both the I and Q coordinates. The angle of rotation indicates the phase, and the distance from the center point indicates the amplitude. This approach to modulation can be expanded out to 64-QAM and 256-QAM or higher. Although 64-QAM is currently considered as the upper threshold in an LMDS wireless system. The higher the density in QAM, the higher a signal-to-noise (S/N) ratio must be maintained in order to meet the required bit error rates (BER).

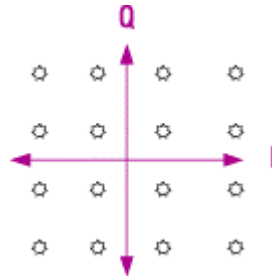

Figure 3.12 - Quadrature Display for 16-QAM

The drawback of PSK is obvious, since as small phase shifts are much more difficult to detect accurately than minor differences in amplitude. Although higher levels of QAM also have lower immunity to noise, interference, and multipath, particularly as the number of states is increased. Still, most of the hardware manufacturers choose to support 4,16,64-QAM techniques over PSK due to the increase data rate.

3.2.3 Duplexing Techniques

In order for the broadband wireless system to support the two-way, simultaneous exchange of information between two devices, a duplexing scheme is required. The techniques used are often referred to as time division duplexing (TDD) and frequency division duplexing (FDD). This procedure can be described by using the conventional telephone system, where it is possible to talk and listen simultaneously. The design criteria most critical to selecting the proper duplexing scheme are the type of traffic that will be carried and the environment in which the system will operate [18].

In a TDD system, a single channel is used for both upstream and downstream traffic. When one party transmits, the other stops and waits for their turn. The duplexing is performed in time as seen in the example shown in Figure 3.13. TDD allows any part of the channel to be used in either the send or receive direction based on demand. This technique is ideal for data transmission, where the traffic is considered “bursty”.

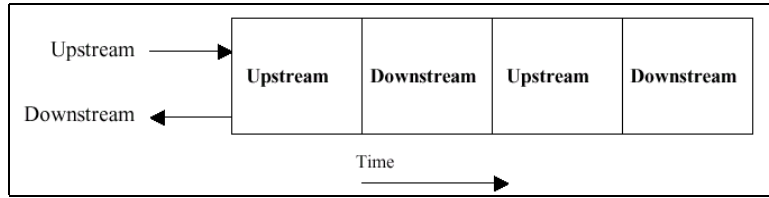

Figure 3.13 - TDD

The FDD system has been in use for decades in the transmission of analog voice, which utilizes a pair of simplex channels for transmit and receive. Between the channels, a “guard band”, that is an unused frequency block isolates the upstream and downstream traffic. The channels are usually of the same size and offer each user a dedicated bandwidth. FDD is therefore often ideal for symmetrical traffic, such as voice and other services that require dedicated service to the customer, as seen in Figure 3.14. In order to allow the simultaneous transmissions, a duplexer will be required at both the hub and customer locations.

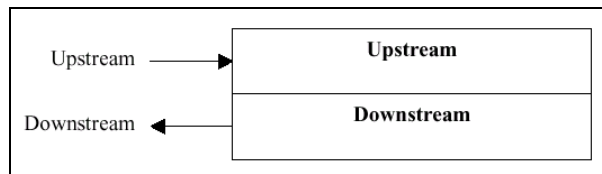

Figure 3.14 - FDD

3.2.4 Reliability

As with all communication systems, the ability to avoid or cope with failures in a wireless network is a major issue with both design engineers and customers. The reliability of a system can be described as “a network’s ability to perform a designated set of functions under certain conditions for specified operational times [17].” With the recent influx of broadband equipment vendors and operators, the issue of reliability will play a significant role in distinguishing the true leaders in this industry. Due to the relative newness of this technology, there has not been much documentation on the actual measured reliability statistics of deployed systems. Again, there are many factors that might influence the

performance of the network. In the following, we will examine some important areas that will affect the dependability of the system.

As stated in Section 3.1, rain attenuation is a major factor that affects the air-link performance in LMDS. A quantitative measure of the effects due to rain is the required equipment to provide a certain percentage of reliability (Exceedance value), as seen in Table 3.2. An example of this is the requirement of a system operating in Virginia that requires a link availability of 99.99%. This translates into a system unavailability rate of up to 52.56 minutes per year. The engineer must then apply the specific rain attenuation value for the particular region (Virginia: K) and evaluate the total link budget that will guarantee a certain level of performance that was previously determined.

Another area in which reliability could be increased is through redundancy. Most LMDS equipment has the ability to provide a redundant system at an added cost. The main advantage of having redundant systems is in case of equipment failures at the hub station. The system will have the ability to switch to the backup system with minimal out of service time if a link goes down due to a failure in the equipment. It is here that the mesh design gains an advantage over the point-to-multipoint system. Since the mesh network is configured to transmit and receive from several nearby nodes, if a link does go down, information can still travel to other nodes, thus reducing the total number of affected customers.

Another suggestion for improving the reliability of a wireless system includes the overlapping of cells in a PMP type network. This effectively allows a service area to receive coverage from two cells. Although this would definitely increase the dependability of the system, the design will effectively cause the total cost of coverage to increase one fold.

3.2.5 BER limitations

Another issue that relates closely to the reliability of the system discussed in the previous section is the measurement of minimum bit error rate (BER). In digital communication, the quality of a digital channel is specified in terms of its BER. The performance of an analog wireless channel is dependent on the received carrier-to-noise ratio (C/N). These two performance measures are closely correlated when it comes to describing the characteristics of a wireless link. Such a correlation is possible through the modulation scheme used to send the digital or analog information across the channel.

The carrier-to-noise (C/N) expression describes the ratio of the desired signal power to the undesired system noise power. If the C/N is too small, a receiver will not be able to detect the transmitted signal. The C/N calculation from the received power and the system noise temperature are shown in Equation 3.7,

$$\frac{C}{N} = \frac{P_r}{kT_s B_N}, \quad (3.7)$$

where: P_r = Received Power (Watts),

k = Boltzman's Constant = $1.38 \times 10^{-23} J / K$,

T_s = System Noise Temperature in Kelvin (K),

B_N = Noise Bandwidth Waveform in Hertz (Hz).

For digital communications systems, a certain minimal BER performance level will be required depending on the type of information being transmitted. The probability of a bit error for a system transmitting data will usually be of the magnitude 10^{-6} , one bit error in one million bits sent. BER is calculated from the type of modulation used and the energy per bit per noise density (E_b/N_o), which is correlated to the C/N as seen in Equation 3.8. The greater the E_b/N_o , the lower the probability of bit error [19].

$$\frac{E_b}{N_o} = \frac{C}{N} * \frac{B_N}{R_b}, \quad (3.8)$$

**True when $B_N = R_s$ **

where: E_b = Energy per bit,
 N_o = Thermal noise,
 C = Carrier Power (W),
 N = Noise Power (W),
 R_b = Bit Rate (Hz),
 B_N = Noise Bandwidth (Hz).

Approximation calculation for bit error rate at different modulation rates is [19]:

$$BER \approx \frac{4}{k} * \left(1 - \frac{1}{2^{\frac{k}{2}}}\right) * Q\left(\sqrt{\frac{E_{b \min}}{2N_o}}\right) \quad (3.9)$$

$$E_{b \min} = \left(\frac{6k}{2^k - 1}\right) * E_b,$$

For: $M_{\text{ary-QAM}}: [M = 2^k]$,
 k = Number of bits/symbol,
 BER = Probability of bit error rate.

Example calculation for most used modulation techniques include

$$\text{QPSK/ 4-QAM: } BER = Q\left(\sqrt{2 * \frac{C}{N} * \frac{B_N}{R_b}}\right) = Q\left(\sqrt{\frac{C}{N}}\right) \text{ when: } B_N = R_s \quad (3.10)$$

and

$$\text{16-QAM: } BER = \frac{3}{4} * Q\left(\sqrt{\frac{4}{5} * \frac{C}{N} * \frac{B_N}{R_b}}\right) \quad (3.11)$$

Figure 3.15 shows BER to C/N ratios for various modulation schemes.

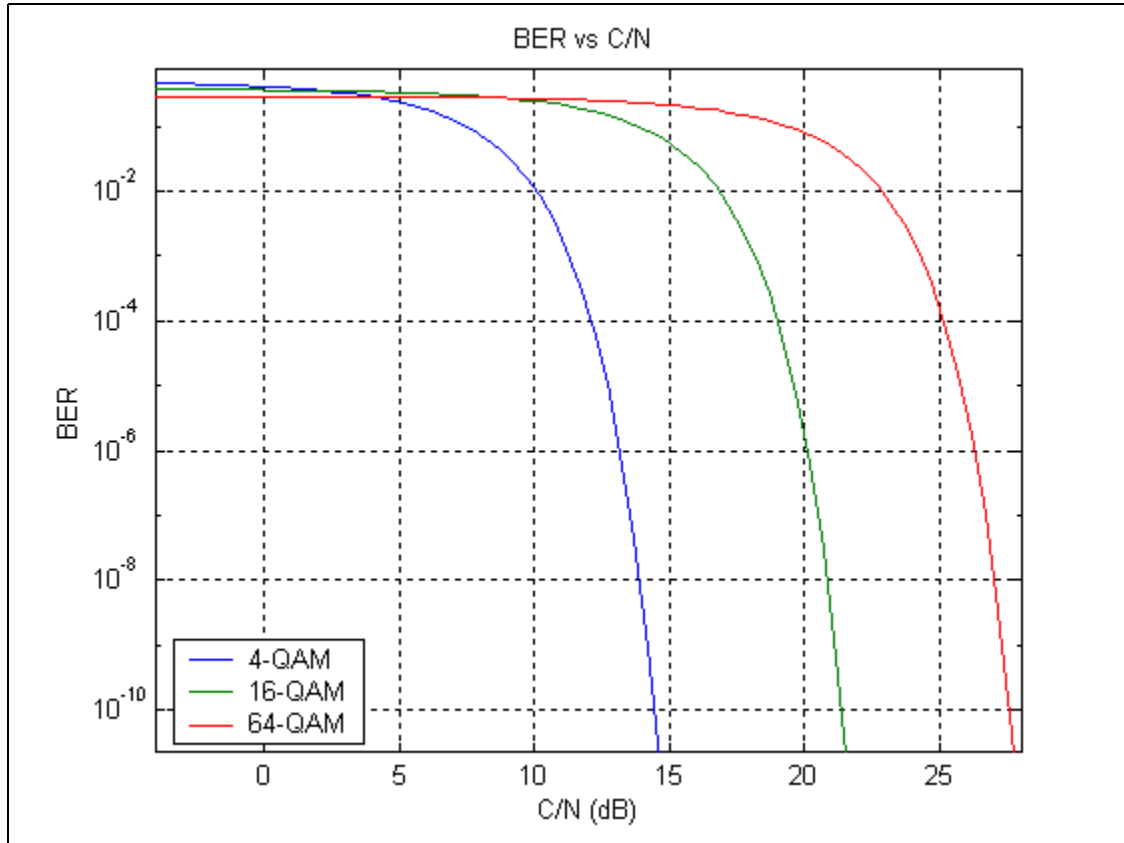

Figure 3.15 Bit error rates for PSK and QAM systems [18]

How the data is encoded also plays an important part in the equation. The data is usually scrambled and a significant amount of forward error correction (FEC) data, such as Reed-Solomon block codes, is also used. Therefore, the system can recover those bits that are lost because of noise, multipath, and interference. A significant improvement in BER is achieved using FEC for a given SNR after demodulation at the receiver, as seen in Figure 3.16. Through Shannon's Law, we can also define the theoretical maximum rate at which bits can be transmitted over a bandwidth-limited channel in a specified signal to noise rate by Equation 3.12,

$$C = B * \log_2 \left(1 + \frac{S}{N} \right), \quad (3.12)$$

Where: C = channel capacity (bit/sec),
B = channel bandwidth (Hz).

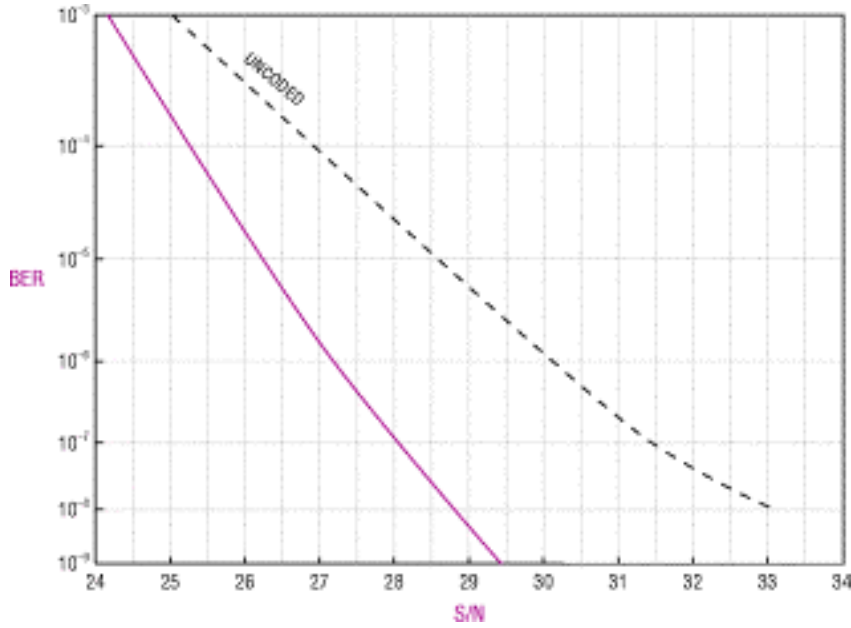

Figure 3.16 - BER against Signal-to-noise for general Coded and Uncoded data streams [18]
 (Pink Curve represents the S/N need to achieve a certain BER for an Coded data stream)

3.2.6 Cell site planning

LMDS network planning is complicated, mostly due to the numerous challenges of radio propagation characteristics. Virtually every measured geographic area has produced a general excess path loss estimation for a particular area that can be characterized by two variables, an excess loss exponent and the path length at which the loss deviates from $1/r^2$ path loss. This path loss is most dependent on the hub antenna height, and the excess loss exponent is primarily dependent on the number of obstacles in the area of interest.

A study done by Gray [19], has provided a prediction model to determine incremental coverage for multiple hubs at any particular path length:

- 1) Incremental Coverage at radius “r”=C:

$$C = 1 - e^{-(k+Mn)/k}, \tag{3.12}$$

Where: M_n = the net link margin (including excess loss) in dB at radius “r”,
 k = function of the standard deviation of excess loss at radius “r”,

2) Incremental Coverage = 0 for “ M_n ” < -k dB.

Figure 3.17 provides an example of the expected coverage as a function of hub spacing and hub antenna height.

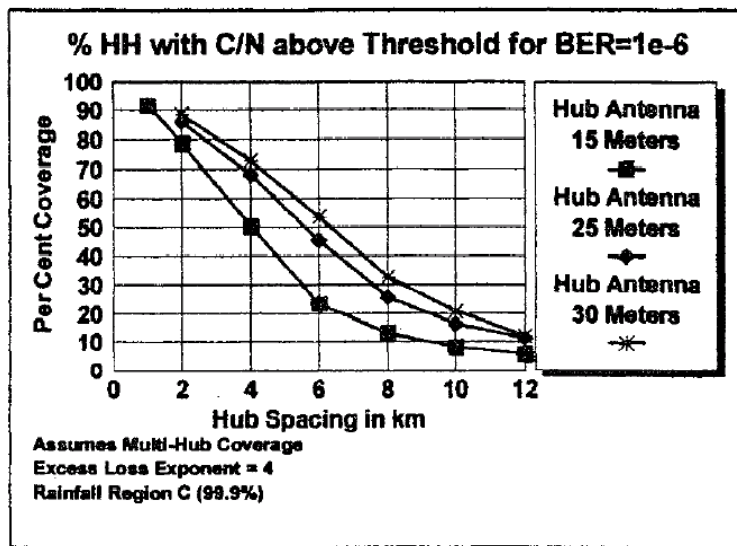

Figure 3.17 - Coverage vs. antenna height and hub spacing [20]

On average, Point-to-Multipoint (PMP) equipment will have an effective coverage range of approximately 5 kilometers. This estimated value is dependent on the attenuation factors, the modulation implemented, and the acceptable bit error rate chosen. One of the keys in effectively deploying a system with relatively short coverage distance such as this is to utilize the technique of frequency reuse [21].

Frequency reuse has been widely used to achieve large coverage areas in a fixed or mobile cellular network. In this design, each hub site within this cellular architecture covers a geographical area called a cell. Typically, in an LMDS system architecture this “cell” is split up or “sectorized” into various combinations of 15°, 30°, 45°, 60°, or 90° sectors depending

on the range and capacity that is required. By limiting the coverage area to within the boundaries of the cell, the same group of channels may be arranged or “frequency planned” in a way that they can be reused to cover different cells that are separated from one another by distances large enough to keep co-interference levels within tolerable limits [3].

The reuse method used in most mobile systems is of a hexagonal cellular pattern as seen in Figure 3.18. For this example, the frequency allocation scheme requires three times the bandwidth allocated to one cell.

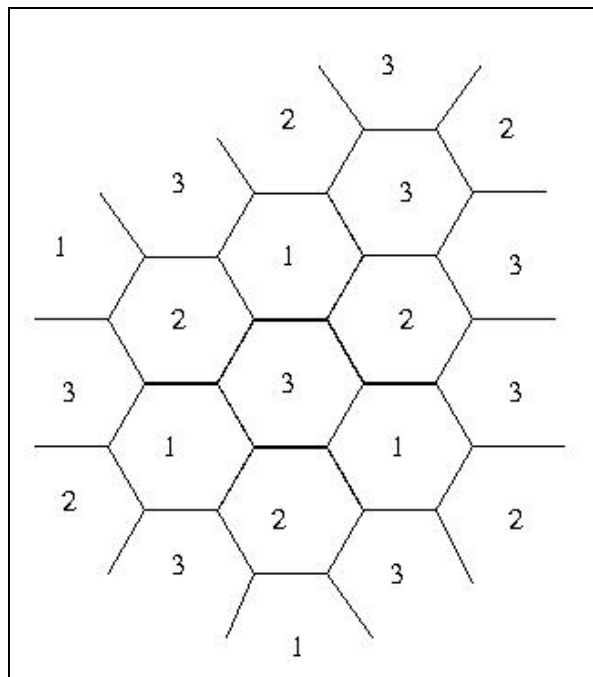

Figure 3.18 - Hexagonal cell reuse pattern

Another alternative will be to use rectangular cells. Each quadrant of the cell in Figures 3.19 and 3.20 are assigned different frequencies, with the frequency assignments being labeled A, B, C, and D for each sector. By alternating frequency assignments, the result is an overall area coverage and a reduced potential for co-channel interference [20].

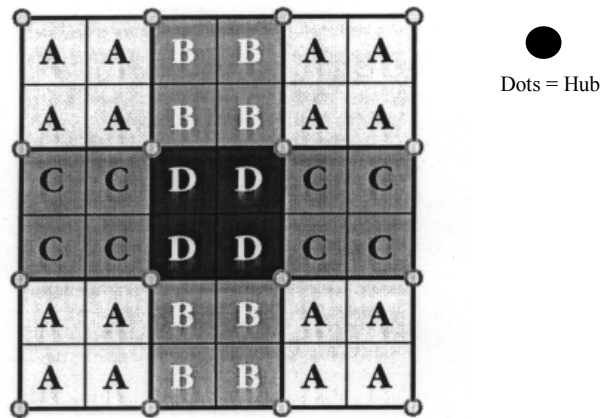

Figure 3.19 - LMDS Frequency Plan for Maximum Coverage

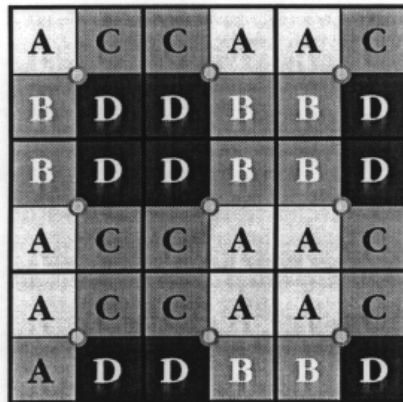

Figure 3.20 - LMDS Frequency Plan for Minimum Hubs

Figure 3.19 shows a layout for maximum coverage where sixteen hub sites are used to cover a service area. In this scenario a user can access one out of four of the hub sites. Figure 3.20 shows a layout for minimum hub site usage where nine hub sites are used to cover a service area. In this scenario users in the corners are serviced only by one hub site and two hub sites can only service users on the edges. The frequency reuse in Figures 3.19 and 3.20 is one. A technique to provide even more capacity is shown in Figure 3.21, where the frequency plan arrangement provides a frequency reuse of two, meaning that two channels support a four-sectored cell. This is possible through the use of frequency diversity and polarization discrimination; this is the alternation of antenna polarizations between horizontal and vertical.

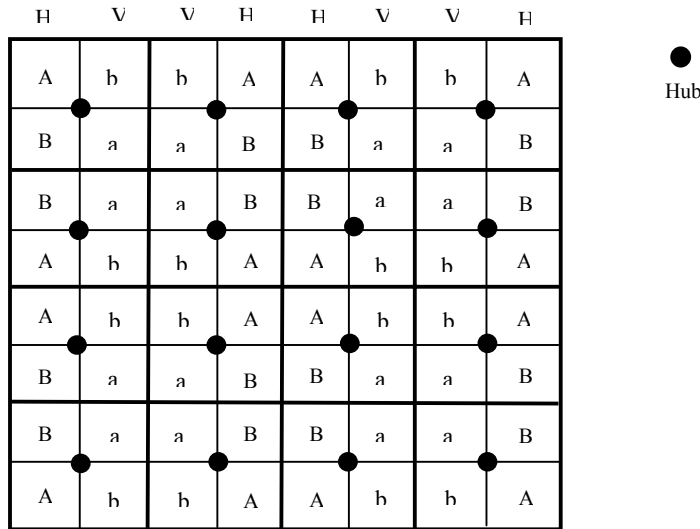

Figure 3.21 - LMDS Frequency Plan with Frequency Reuse of Two

The following points summarize the attributes that require attention while designing the LMDS cell [25]:

1. Cell size selection has to be decided based on the desired reliability level.
2. Cell coverage overlap is an issue that has to be taken into consideration while designing the cells.
3. Subscriber penetration, the number of subscribers having required signal level to achieve quality of service, must be decided
4. The number of cells in a sector is dependent on the cell size decided.
5. Based on the traffic capacity of the area, the cell size and properties are fixed.
6. Cell overlaps that exceed the normal value allowed can affect the quality of service.
7. Link budget is an estimation of the maximum distance that a user can be located from the cell while still achieving acceptable service reliability.
8. Capital cost per cell is used to estimate the network capital requirement.

The issue of cell site planning, on the other hand, does not really affect the layout of a MESH network. The insertion of each customer node (CN) simply relies on customer demand, or the insertion of a seed node (SN) if further coverage is desired. In Section 3.2.8,

we will provide a further detail on the system architecture of both point-to-multipoint and Mesh technology.

3.2.7 User/area

In broadband wireless systems, there is always a need to find ways to reach further, thus serving more customers. The obstacles to realizing this fact have always been either bandwidth or power limitations. However, not much has been known concerning the impact of sector size on a system. In this section, we will examine how variations in sector size affect the number of users served in a sector.

Beginning with a simple system, the following initial specifications are made:

- The hub can serve a maximum number of users (N_{\max}).
- Users are uniformly distributed in a given area (N_{area} users / sq. area).
- Each user gets a guaranteed bandwidth at a given bit error rate (BER).

At this point, an assumption that $N_{\text{served}} \leq N_{\max}$ will be made. Ultimately, we want to determine the relationship between N_{served} and the size of a particular sector. The transmitter power of the hub is kept constant throughout this investigation, since the BER is directly related to the amount of power that is transmitted.

We know that the effective isotropic radiated power (EIRP) is

$$EIRP = G_t P_t = \left(\frac{30,000}{\theta_v \theta_h} \right) P_t \text{ (watts)}, \quad (3.13)$$

where θ_v is the vertical beamwidth, kept constant at 3° , and θ_h is the horizontal beamwidth.

Keeping the receiving antenna gain G_r constant,

$$Pr (dBW) = EIRP - PL + G_r, \quad (3.14)$$

$$\text{Where: } PL = \text{path loss} = \left(\frac{4\pi d}{\lambda} \right)^2,$$

$d = \text{maximum reach distance} .$

By changing the sector size while keeping the area constant, the number of users that are uniformly distributed in the area will remain the same.

For a fixed RF bandwidth, the amount of bandwidth (bps) that can be guaranteed to each user changes as the modulation index (4,16,64 QAM) changes. Higher modulation indices will require higher C/N ratios, thus more transmitter power is required to maintain the acceptable BER. If the power of a particular system is fixed and the guaranteed bandwidth (bps) per user increases, then the number of users that we can fit into a unit of RF bandwidth will decrease. This, however, does not depend upon the sector beamwidth because the area of a sector is constant. This implies that N_{area} remains the same regardless of how wide or narrow the size of a sector is. The justification of this statement can be explained by an example of changing the sector width. As the sector width becomes smaller, the antenna gain increases, thus a resulting increase in the distance of coverage. This then implies that the total area of coverage between a smaller sector width versus a larger sector width will be the same.

3.2.8 PMP vs. Mesh

Through the examination of various equipment vendors and the techniques in which their systems are implemented, we have identified two major deployment strategies for LMDS networks: Point-to-Multipoint and Mesh.

PMP

As its name suggests, a Point-to-Multipoint system revolves around a central node (Hub) in which the data is centrally accessed between outside networks and various remotes. A major benefit of a PMP system is its ability to service many remotes if the hub location is selected at an optimum site. This system will prove to be the most cost effective if there are a large number of customers within the Hub location. However, this hub location often will not cover all areas in its range due to obstructions. Ultimately, the bottom line lies in the total coverage available to users with a system layout that is most profitable.

If the initial coverage sector has reached its full capacity, we can accommodate future growth by simply dividing the original sector into two or more sectors. This will allow subscription from more customers while utilizing the same hub/base Station. If coverage outside of what the current Hub site will reach is required, another new Hub location could be established at extra cost to provide the additional coverage.

Some of the disadvantages of the PMP include the high cost of building a base station. Profit generated from the hub site can be realized only if a minimal initial coverage is planned with a set of customers. Also, with an increase number of deployed hubs and sectors comes an increase in interference between the base stations, thus reducing spectral efficiency.

Mesh

In a Mesh configuration, each node acts as a hub for other nodes without the actual high cost of establishing a hub. This deployment technique will allow greater reliability, in which redundancy plays a major role. Another benefit of a mesh system lies in its ability to work around obstructions that would affect a Point-to-Multipoint system. In our pricing analysis, we will examine if this method will provide an economically viable solution for the type of coverage required.

Unlike the PMP system, the Mesh network can easily support additional customers by adding an extra CN (Customer Node). The system will self-reconfigure the Mesh network after the addition of the new nodes to establish the best routing paths, hence ensuring maximum redundancy in the system. This design reduces the cost of adding more radios at the Hub due to sectorization or the building of any extra Hubs. Depending upon the data rate demands of the customers, more TNCP (Trunk Network Connection Points) nodes might be necessary to increase the overall throughput of the system.

A disadvantage of a Mesh network is that a cluster of customers must locate within a short range of 2 to 3km between each other to truly render the effectiveness of redundancy in this system. Another disadvantage is the Mesh design's maximum peak data rate of only 25Mbps.

3.2.9 Link/Power Budget

In the design of any communication systems, the outcome of a link budget is crucial. The most important elements that are required in any link budget include the required power at both the transmitter and receiver, and the amount of path loss associated with the link. This information will allow the engineers to design a system that is able to reach a certain coverage area.

The fundamental equation used by communications engineers is the Friis transmission equation. This formula calculates the total power received from the transmission after accounting for free space path loss and other environmental attenuations discussed in chapter 2. Below is the explanation of the Friis equation (3.15)

$$P_r = P_t + G_t + G_r - PathLoss \text{ (dB)}, \quad (3.15)$$

where: P_r = Received Power (dBW),
 P_t = Transmitted Power (dBW),
 G_t = Transmitter Gain (dB),
 G_r = Receiver Gain (dB),
 $PathLoss$ = (dB).

Effective Isotropic Radiated Power (EIRP)

Wireless engineers usually refer to the EIRP as the product of the transmit antenna gain with the transmitted power, as shown by

$$EIRP(dB) = 10 \log_{10} (P_t G_t). \quad (3.16)$$

This quantity is usually used to characterize the transmitter of a radio link.

Path Loss

For every radio communication link, loss is imminent. The question is how much of the loss can be tolerated. As carrier frequencies increase, the loss incurred by the system also increases due to the shortened wavelength of the signal.

Free space path loss is defined as signals that are lost to spherical spreading. Two elements are involved in the calculation of free space path loss: carrier wavelength, λ , and distance, d .

$$Free\ Space\ Path\ Loss(dB) = 10 \log_{10} \left(\frac{4\pi d}{\lambda} \right)^2 = 20 \log_{10} \left(\frac{4\pi d}{\lambda} \right). \quad (3.17)$$

Other environmental attenuations (A_e) that are eminent at high frequency transmissions include rain fading, vegetation, and obstructions, as explained in Section 3.1.

Noise Power

The amount of noise in a system is dependent on the noise bandwidth and the system equivalent temperature of the particular transmission. In digital communications, the modulation scheme determines the number of data bits that can be squeezed into a symbol. For the same system bandwidth, a high modulation index will be able to drive the system to a higher data rate, and vice versa. The noise power, P_N , can be calculated as shown below,

$$P_N = kT_s B_N \quad (\text{Watts}), \quad (3.18)$$

where: k = Boltzmann constant ($1.38 \cdot 10^{-23}$ J/K),
 T_s = System Noise Temperature (K),
 B_N = Noise bandwidth (Hz).

Carrier to Noise Ratio (C/N)

As mentioned in Section 3.2.5, C/N ratio is one way to determine whether or not the receiving antenna is able to detect a signal over elements of noise. An acceptable quality based on the bit error rate (BER) allows the systems engineers to determine the minimum C/N value that is needed for the chosen symbol rate or noise bandwidth. Again, the C/N can be calculated with the equation below,

$$\frac{C}{N} = \frac{P_r}{kTB_N}.$$

Substituting the Friis equation changes the equation above, and including the various environmental attenuation in the system yields:

$$\frac{C}{N} (\text{dB}) = \text{EIRP} + G_r - \text{PathLoss} - (k + T_s + B_N) - A_e, \quad (3.19)$$

where: $k = (1.38 \cdot 10^{-23} \text{ J/K}) = -228.6 \text{ dBW/K/Hz}$,
 A_e = Environmental attenuation (dB).

The relationship between the energy per bit per noise power spectral density (E_b/N_o) and C/N, for the case of an ideal raised root cosine filter revisited:

$$\frac{E_b}{N_o} = \frac{C}{N} \cdot \frac{R_b}{B_N}, \quad (3.20)$$

$$\frac{E_b}{N_o} = \text{EIRP} + G_r - \text{PathLoss} - k - T_s - R_b. \quad (3.21)$$

From Equation 3.21, we can determine whether or not we have satisfied our bit error rate requirement as mentioned in Section 3.2.5.

Calculating a Link Budget

With the equations presented above, a link budget can be generated. Communications engineers use the table as a guideline for estimating the quality of their wireless link. The link budget will show the total power received and whether or not the design will have the necessary margin or “budget” in received signal strength to operate with a desired link quality. The following is a sample link budget for a QPSK radio link for a 90° sector.

Table 3.5 Downstream link budget for rain region C and a threshold BER of 10^{-6}

Parameter	Values @ 2 km	Units
Frequency	28	GHz
Tx Power Spectral Density	-20.8	dBW/MHz
Power Back-off	3	dB
Tx Antenna Gain (90 degree azimuth)	14	dBi
EIRP	-9.8	dBW/MHz
Path Loss	121.5	dB
Band Edge Allowance	-3	dB
Rainfall Allowance (Region C, 99.9%)	3.24	dB
Receive Antenna Gain	35	dBi
Minimum Received Power	-100.9	dBW/MHz
Receiver Threshold (system NF=6dB)	-138	dBW/MHz
Minimum C/N	37.1	dB
Margin for BER = $1 e^{-6}$ (14 dB min)	23.1	dB
Coding Gain	8	dB
Implementation	3	dB
Link Margin @ Max Rainfall	18.5	dB

The minimum C/N including rainfall attenuation and minimum BER of $1e^{-6}$ shown in Table 3.5 is 23.1dB. With an 8 dB improvement from coding gains and an allowed implementation margin of 3 dB, the final allowable link margin is 18.5 dB. This example, however, does not include possible attenuations from obstruction or foliage.

3.3 Network Issues

LMDS can carry data, voice, and video traffic, which are typically transported from the customer location via a digital signal (DS1, DS3) or Ethernet interface. A successful wireless network will require the integration of existing network technology solutions, services to customers, wireless network engineering, and a well-designed choice of broadband wireless equipment. In this section, we will examine the issues involved in the integration process and the types of services provided.

3.3.1 Service Provided

The possibilities that the Broadband Wireless solution offers is the ability to satisfy the thirst for larger bandwidth in the access networks. The growth of Internet/Intranet traffic and local area networks (LANs), as well as a growing interest in voice over Internet Protocol (VoIP), has generated an increasing demand for systems with the ability to integrate various services into one solution. Operators are focusing on an access system that satisfies the growing demand for the data and multimedia applications that these businesses require.

Considering the types of applications that will be operated in these broadband networks, systems have been optimized for packet switched traffic, thus providing not only new and superior services, but also a more efficient support for the existing services. The use of asynchronous transfer mode (ATM) provides efficient support and dedicated capabilities for existing applications, such as voice and video, as well as quality of service (QoS) for other IP-based applications.

With an average channel bandwidth of 8 to 10 MHz per channel, the LMDS system allows the possibility of much greater information transfer rate than what the other access technologies can offer. Currently, the first generation systems have approximately 45 Mbps throughput per sector, with the possibility offer up to 155 Mbps connectivity in the near future. This abundance in bandwidth will provide the capability for real-time video (MPEG-2) interface, which usually requires 3 Mbps for quality transmission.

3.3.2 Connectivity

In this section we will provide an overview of the network connectivity issues of an LMDS system and describe how this translates to the various services that we will be able to provide to our customers. The first stage in connecting the broadband wireless network is the interface between the hub/base-station to other network services such as the PSTN (Public Switched Telephone Network), the ATM (Asynchronous Transfer Mode) packet switched networks, the Internet, and video networks. These services will then be multiplexed using an ATM multiplexer/switch located either at the Hub or a central location such as at the Internet Service Provider (ISP).

This leads to the second stage, which essentially takes the previously packetized data from the Hub and transfers it through the radio air-interface to the Remote/CPE. At this stage the packetized data from the ATM switch is passed through the Sector ATM controller, which performs duties such as SNMP (Simple Network Management Protocol) and multiplexing. The data is then multiplexed and sent to the customers through the air-interface based on a specific modulation scheme chosen for the link. The final stage in network connectivity resides at the Remote/CPE.

The customer premise equipment (CPE) varies widely from vendor to vendor. All configurations include indoor digital equipment, modulators, and outdoor mounted microwave equipment. The customer premise equipment may access the network using TDMA or FDMA. Typically, LMDS CPE will concentrate inputs from a number of subscribers sharing one access point, and will be provided with 10BaseT Ethernet and structured or unstructured T1 ports. Some of the differentiating factors between the various manufacturers are the accommodation availability to phone services (PBX connectivity), video capabilities (MPEG), and other hardware implementations. The customer locations can range from large office complexes to residential sites. The described connectivity can be seen in Figure 3.22.

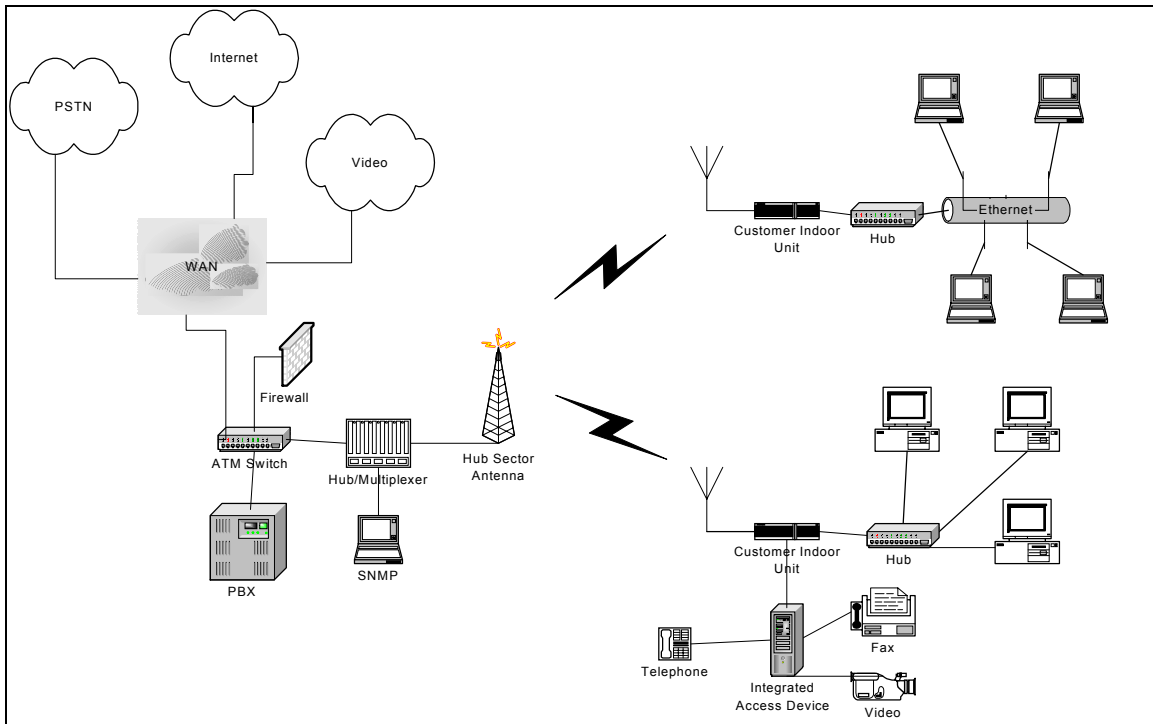

Figure 3.22 - LMDS Connectivity

3.3.2 Quality of Service (QoS)

The topic of quality of service is a term that is used very loosely in the LMDS arena. Due to the lack of standardization, there is no set way of providing accurate levels of service to the customers. When discussing end-to-end QoS capabilities, some might see it in terms of link quality where BER and reliability is an issue. For others who are perhaps more network oriented, the discussion might deal more with bandwidth provisioning, queuing, traffic shaping, jitter, admission control, or flow control. Since we have already discussed the topic of link quality, in this section we will focus on QoS issues for ATM and IP network environments.

The need for the LMDS network to support signaled Quality of Service features is still in its exploration stages. Most users with perceived QoS requirements have an expectation of performance for Virtual Private Network (VPN) or similar "intra-net" applications. However, those users subscribing to voice services or interested in video-conferencing will be interested in network-based QoS. Hence, the network must support some appropriate form of QoS, but

this may be done with IP or ATM as appropriate. Table 3.6 shows the OSI model (Open System Interconnection) and where ATM and IP protocols belong on the OSI stack.

Table 3.6 OSI Network Layers [22]

OSI Layer	Function	Example
Application	Provide special network access to applications	HTTP and FTP
Presentation	Compression and Encryption	Secure Socket Layer (SSL)*
Session**	Maintaining Connections	Net bios
Transport	Insure data delivery	TCP, SPX and NetBEUI
Network	Direct data to address	IP, IPX and UDP
Data Link	Transfer data units and error checking***	ATM, Ethernet and Token Ring
Physical	Transfer ones and zeros	Cables and network devices

ATM

In many of the current LMDS systems, ATM (Asynchronous Transfer Mode) is the applied transfer mode used for packet switching. With the distinguishing characteristics of being a fixed-cell, connection-oriented network (virtual circuit), ATM allows for a simpler switching process as well as error control and flow control. ATM is a difficult protocol to map onto the OSI model, thus it is sometimes referred to by its own protocol architecture as shown in Figure 3.23. In ATM, QoS is defined at the time a virtual circuit is set up.

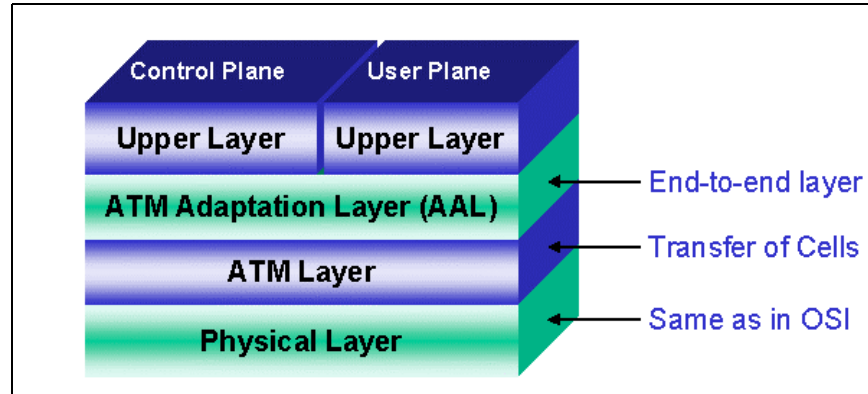

Figure 3.23 - ATM Protocol Stack

The ATM layer can provide a variety of services for cells from an ATM virtual connection such as bit rate guarantees that will be available to different service classes in the AAL layer.

ATM Service Classes include the following:

- Constant Bit Rate (CBR) specifies a fixed bit rate for Circuit Emulation (CE)
- Variable Bit Rate - Real Time (VBR RT) provides a specified throughput with end-to-end synchronization, but data is not sent evenly; used for real-time voice and video
- Variable Bit Rate - Non-Real Time (VBR NRT) provides a specified throughput without end-to-end synchronization
- Available Bit Rate (ABR) provides a guaranteed minimum capacity but allows data to be bursted at higher capacities when there is excess capacity in the network, ABR services are generally not implemented in ATM networks and services
- Unspecified Bit Rate (UBR) does not guarantee any throughput, used for non-time-critical applications, such as file transfers

The characteristics of each service class are shown in Table 3.7.

Table 3.7 ATM service classes [24]

Characteristic	CBR		Rt-VBR		Nrt-VBR		ABR		UBR	
	Constant Rate	Bit	Real-time Variable Rate	Bit	Non-real-time Variable Rate	Bit	Available Rate	Bit	Unspecified Rate	Bit
Bandwidth Guarantee	√		√		√		Optional		X	
Suitable for real- time traffic	√		√		X		X		X	
Suitable for bursty traffic	X		X		√		√		√	
Feedback about congestion	X		X		X		√		X	

Because ATM was designed to support all types of services, including voice, video, and data, different services would have different AAL needs. The ATM Adaptation Layer (AAL) provides services such as segmentation and reassembly of upper layer data, which are between upper layers (network, transport,...) and the ATM Layer. The AAL has five different protocols that provide these different types of services.

AAL service layers include:

- AAL 1 – designed to transport circuit traffic such as voice and video
- AAL 2 – similar to AAL1, for application requiring guaranteed bit rate
- AAL 3/4 - designed to support packet data running over ATM
- AAL 5 – designed for computer communications, proposed to overcome the shortcomings of AAL 3/4

Figure 3.24 demonstrates the classes of services that are applicable to the various service layers.

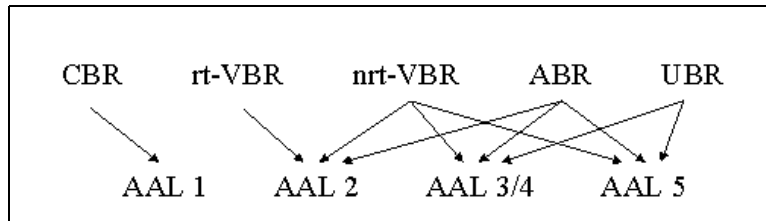

Figure 3.24 - ATM Service Class associations with Service Layer [23]

Internet Protocol

Quality of Service is not one of the strong points of IP (Internet Protocol), but with the current explosion of Internet usage, there is a great demand for the ability to provide QoS to the customers. IP is a connectionless packet switching protocol. It currently operates on a “best-effort” service. The available mechanisms in which some levels of QoS service classes can be implemented on IP are IntServ/RSVP and DiffServ.

RSVP (ReSerVation Protocol) is a signaling protocol designed to enable applications to dynamically reserve network bandwidth, thus requesting a specific QoS for a data flow. It is a receiver-oriented service (established at the end user) and allows different receivers in a multicast group to allocate different QoS guarantees.

IntServ (Integrated Services) is aimed at providing real-time services and an ability to share dynamically the available link capacity by reserving resources for individual packet flows. These services would be in addition to the currently available best-effort services. This model is similar to that of ATM QoS in the fact that it inherits the connection-oriented network approach. It is for this reason that IntServ has not been widely adopted in the Internet because the connection-oriented approach assumes a “flat” model of the Internet. The “flatness” occurs where the number of connections required to handle all traffic of the Internet leads to a state explosion in the core routers. However, the resource admission control concept defined within IntServ is a useful tool to manage application level traffic with strict QoS requirements.

IntServ also extends the duties of the routers to include understanding RSVP, maintaining flow state, reserve resources, and resource controlling. Such a control involves scheduling, classification and queuing management all done at the router. The IntServ standard assumes that routers along a path sets and maintains the state for each individual communication.

Differentiated Services (DiffServ) is a multiple service model that can satisfy differing QoS requirements. The approach is to divide QoS into a number of functional elements to be implemented in network interfaces. Each element provides a traffic control function or forwarding treatment called “per-hop behavior” (PHB) on a packet-by-packet basis. The network uses the QoS specification to classify, mark, shape, and police traffic, and to perform intelligent queuing. Typically, Differentiated Services is appropriate for aggregate flows because it performs a relatively coarse level of traffic classification.

Diffserv is different form Intserv primarily in its level of aggregation, scalability and location of complexity. Intserv, as seen above, would have to maintain state information on each of the nodes. This entails a large load especially on large or fast networks. Diffserv aggregates the individual flows at the core of the network, thereby taking the load off of the routers where it mattered most, at the core where traffic is the highest. Also Diffserv does not depend on RSVP like Intserv. The complex task of classification is undertaken at the boundaries where speed is relatively less important. Speed however is very important at the core routers and Diffserv does not burden these routers with complex tasks. In Diffserv the classification of the packet and traffic conditioning takes place at the edges and is more coarse level of traffic than in the Intserv model.

Diffserv is flexible. The services provided and traffic conditioning is sufficiently decoupled from the forwarding behavior at the core. Thus new services can be easily added to the existing ones. This flexible “hop-to-hop” feature, however, limits the capabilities of QoS to a level that is determined by its weakest link.

Chapter 4

Deployment in a Commercial Environment:

South Boston County: A Case Study

4.1 Introduction

In 1998, Virginia Polytechnic Institute & State University (Virginia Tech) obtained the LMDS BTA (Basic Trading Area) spectrum licenses for much of Southwest Virginia, including South Boston (under Danville BTA), in an FCC auction (see Figure 4.1). Since then, the faculty of Virginia Tech have been actively researching ways to implement this new technology to invigorate the region's economy by offering high technology corporations the opportunity to gain high capacity communications capabilities at a greatly reduced cost. LMDS is particularly attractive to the rural parts of Virginia that need competitively priced broadband communications in order to productively participate in the information technology boom that Northern Virginia is enjoying.

The Center for Wireless Telecommunications (CWT) at Virginia Tech was tasked with developing an LMDS-based broadband wireless system architecture that will provide economical "last-mile" connectivity between a fiber based Wide Area Network (WAN) and several customers in South Boston, Virginia. The motivation for this deployment is to boost the area's economy that has recently been hit hard by cutbacks in the tobacco and textile industry. The local government hopes that providing state-of-the-art broadband connectivity to both new and existing businesses will attract other business ventures to the region. This was a major appeal for the main customers of this project such as the developers of Riverstone Business & Technology Park, the South Boston Continuing Education Center, and the AXA training facility.

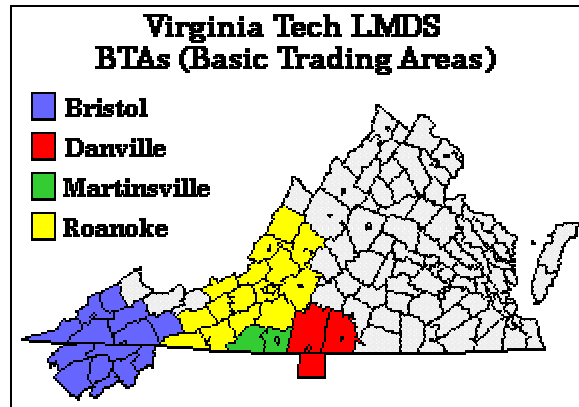

Figure 4.1 - Virginia Tech BTA's

Riverstone Business Park is a new development in Halifax County where developers want to offer prospective park tenants state-of-the-art broadband connectivity, both for Internet access and for internal use. The AXA training facility is an historic converted plantation that serves as the North American training grounds for the insurance and financial services conglomerate. The South Boston Continuing Education Center is an extension of Longwood College.

The issues considered in this design involved maximum coverage and capacity while providing quality service at minimum cost. Through the integration of engineering, geography, and business aspects, we were able to develop optimal wireless solutions for this community. Provided in this analysis are several design options and possible future coverage based on equipment from different vendors.

It is anticipated that this system (tentatively called the Riverstone Wireless Network) will rapidly expand to serve South Boston, other industrial complexes such as Virginia International Raceway, and ultimately homes and small businesses throughout Halifax County. Upon its completion, the network will serve as a model for other rural areas needing similar systems. This will allow a reduced amount of time required to develop the system architecture of a broadband wireless network for future deployments.

4.2 Approach

The South Boston project provides a good opportunity to explore deployment strategies due to the relative small number of customer sites. The first step in providing a network such as South Boston is to develop the network architecture and specify the equipment needed to build it. To do this we must:

- Identify and locate our target customers
- Determine the type of network capacity and services required by the users
- Determine the available WAN connectivity
- Determine the network topology that will best serve this mix of users through GIS
- Examine possible equipment vendors for various architecture designs
- Determine the number of radio hubs that are required and where they are located
- Determine the required radio and network interface specifications
- Determine the pricing points and potential revenues for the services, based on wire line services at competing locations

Wireless networks must be designed efficiently and effectively to provide a sound business case for the operation of the network. Services offered via a broadband network must be priced comparable to existing services to encourage customer migration and retention. The importance of planning the physical layout of the network (tower locations, and heights, etc.) is well understood, but the effect of the network access requirements on the cost of the radio system is not always appreciated. Without proper planning, the costs of connecting a hub to the fiber backbone or of connecting a user radio to a building LAN (Local Area Network) may be surprisingly high. In our analysis we will consider the various elements in networking and ways in which it could be optimally implemented. The resulting system design will be one that has the flexibility of allowing additional customers as the market matures.

The LMDS design approach for South Boston is shown in the block diagram in figure 4.2.

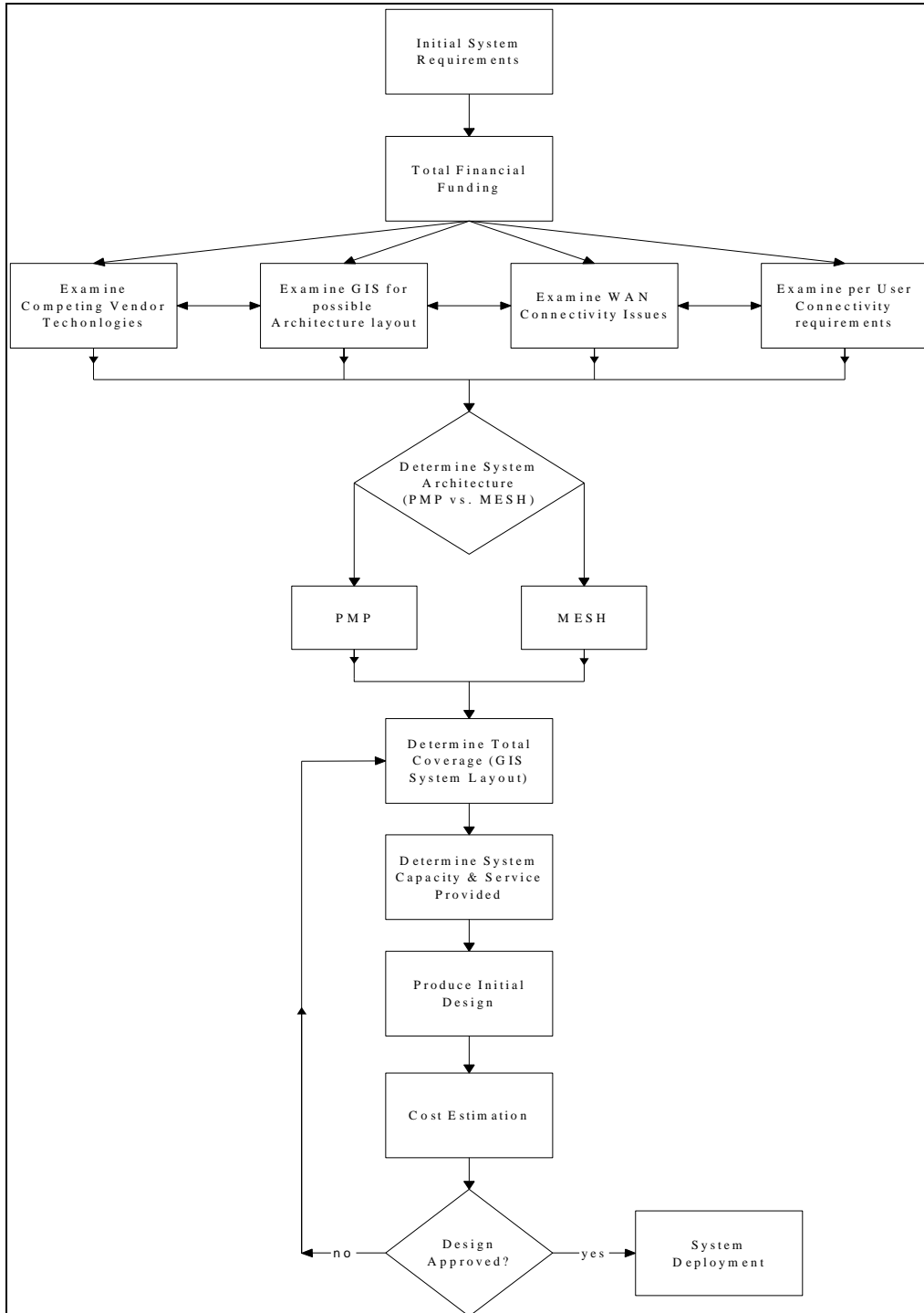

Figure 4.2 - Deployment Strategy Block Diagram

4.3 System/ Customer Requirements

The main objective of this project is to provide a high-speed wireless network service that surpasses what customers are currently receiving. The design must offer the required service at a cost that is competitive to a wired network. Based on interviews with the representatives of South Boston businesses, we found that the highest connectivity in the area at the present time was that of a dedicated T1 line and the cost of such a line was as much as five thousand dollars per month. The following is a summary of the system requirements for the proposed LMDS network:

- Provide coverage to primary customers (AXA, CEC, and Riverstone Business Park)
- Provide coverage to secondary customers (municipal offices, schools, hospital/physicians offices, O'Sullivan, ABB, Dollar General, ISP's)
- Provide a high capacity network to customers (multiple T1 access/ remote)
- Provide a Mesh or Point-to-Multipoint system to various remote locations with the ability to allow further expansion in footprint coverage
- Provide a reliable system with competitive pricing

The secondary customer list was developed by identifying those businesses and groups that would have a need for high speed connectivity, that were locating within the proposed service area, and that had expressed interest in the project. A meeting was held at the beginning of the project with interested businesses and local governments represented. During this meeting it was determined that there was high interest from the community in general for broadband connectivity from many of the secondary customers. Figure 4.3 shows the location of the primary as well as some of the secondary customers for this project.

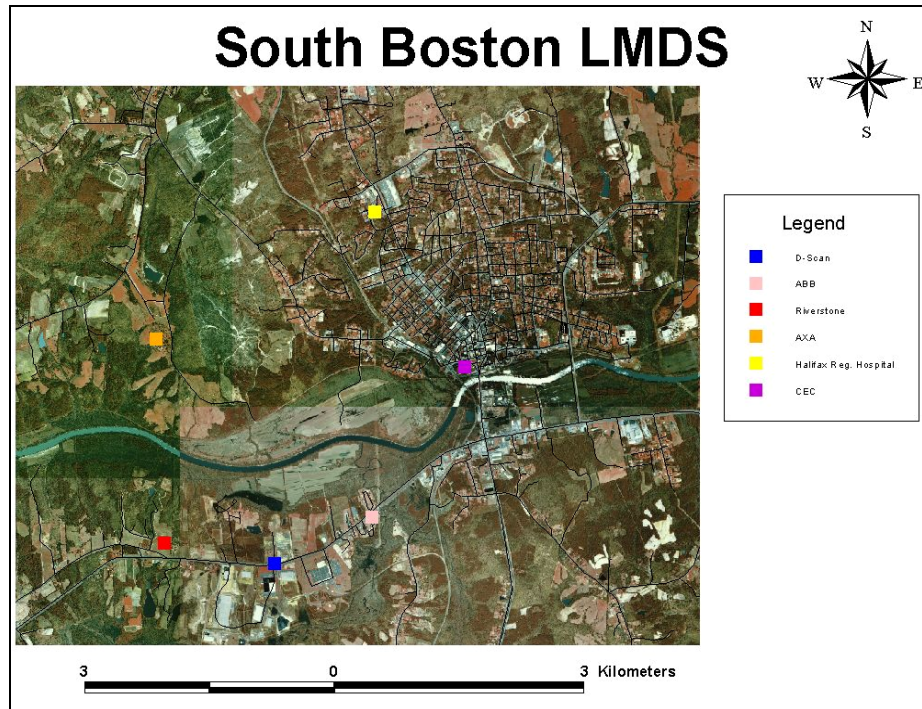

Figure 4.3 South Boston: Primary and Secondary Customers

4.4 User Connectivity

The requirements of the different sites are varied, but one common need is cost-effective access to the Internet. Some sites (e.g., ABB, Halifax Regional Hospital) also have interest in VPN (Virtual Private Network)-type connectivity within the Commonwealth of Virginia. Most sites would have some form of LAN infrastructure, terminating in a WAN-capable IP router. As described earlier, the planned connectivity to customers at the remotes will be multiple T1/E1 Frame Relay, T1/E1 Circuit Emulation, or Ethernet 10BaseT access. These accesses are made available when the Remote's ODU receives the transmitted signal (packetized data) from the Hub, which is then connected to an ATM service module that converts the ATM data to the access interfaces mentioned above. At this point, the customer has the ability to configure and allocate the resources provided by the broadband wireless network according to the client's desired LAN architecture. The amount of Internet bandwidth varies by the site, with typical LAN applications generally needing more than a single DS-1. The proposed design will offer initial interfaces to businesses of $n \times$ T1 and Ethernet connectivity with the possibility of expansion to ATM 25 and DS-3 in the future.

4.5 Wide Area Network Connectivity (WAN)

The wide-area connectivity between networks in the Commonwealth of Virginia and to the Internet is anticipated to be Sprint's VirginiaLink or Net.work.Virginia service. (See Figures 4.4 and 4.5 for WAN backbone connectivity) Such an offering would entail a single high-speed (e.g. DS-3 or OC-3) access circuit, including access to some provider's Internet service at comparable high-speed. This access circuit would be delivered to the LMDS hub site, with LMDS remote sites sharing this access circuit for wide-area connectivity.

Assuming VirginiaLink as the access and Internet provider and ATM as the access technology used between the LMDS remote and hub sites, a design that includes an ATM switch at the LMDS hub site would be expected. The remote sites would then have ATM permanent virtual circuits (PVCs) configured between their remote site and any other remote sites, any sites within the scope of VirginiaLink, and the Internet gateway router, as required. On the other hand, LMDS equipment that uses some other access technology to perform the data link function (e.g., Ethernet), would most likely need an IP router at the LMDS hub site and an appropriate IP routing design to deliver traffic efficiently to each other, other sites within Virginia, and the Internet.

Multiple Internet access providers may also be specified. Each subscriber could peer directly with the Internet access provider, if they desire this service, with no significant additional charge for this peering relationship. Similarly, each site may wish to have virtual point-to-point connectivity to sites within the Commonwealth of Virginia, and these virtual configurations should entail nominal extra cost for their initial configuration. With the limited initial deployment of remotes in this proposal, we feel that a DS-3 connection will provide sufficient capacity for the initial deployment.

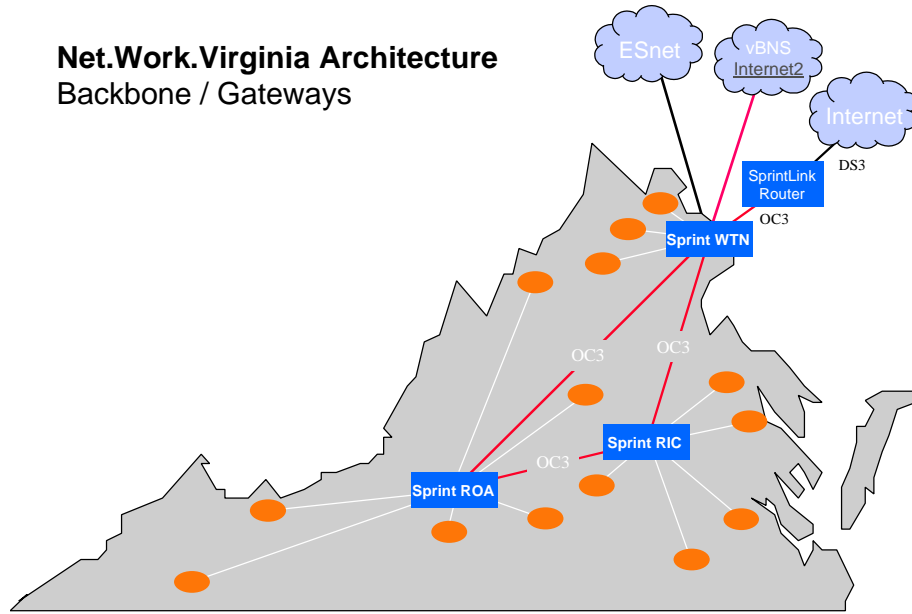

jmc 1/3/97

Figure 4.4 - Net.Work.Virginia Connectivity

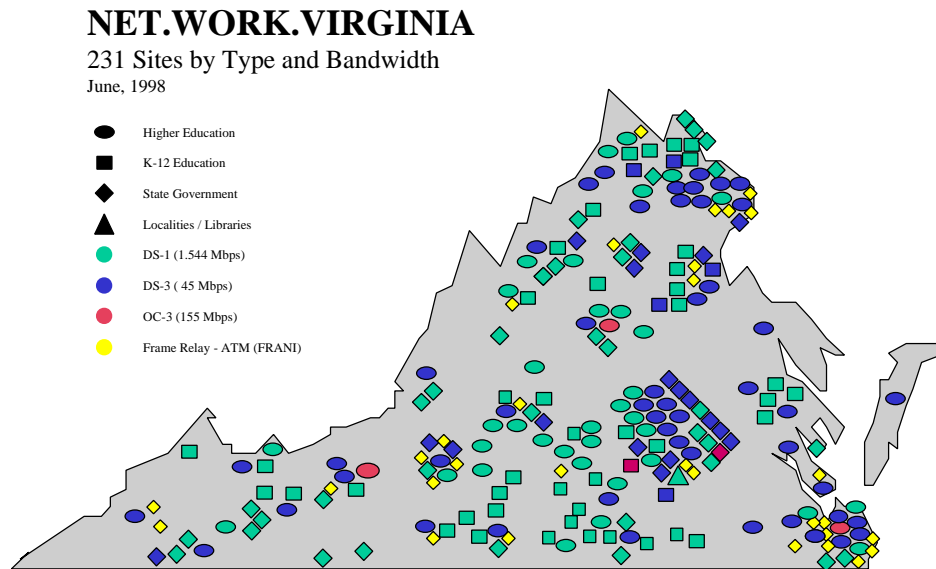

Figure 4.5 - Net.Work Virginia Service Sites

4.6 Geographic Considerations

Terrain

When deploying an LMDS system, terrain and distance from the base station to the remote site are two of the main considerations. LMDS requires “line of sight” from the base station to the remote. Therefore, the terrain is extremely important. Fortunately, the terrain surrounding South Boston is relatively flat with only a few “major” elevation changes, as seen in Figure 4.6. Equipment currently available generally has a maximum range of about 6 kilometers; which makes this technology truly a last mile solution. The area that needs to be covered by the project is relatively small. Therefore, the terrain in South Boston is advantageous for deploying an LMDS system.

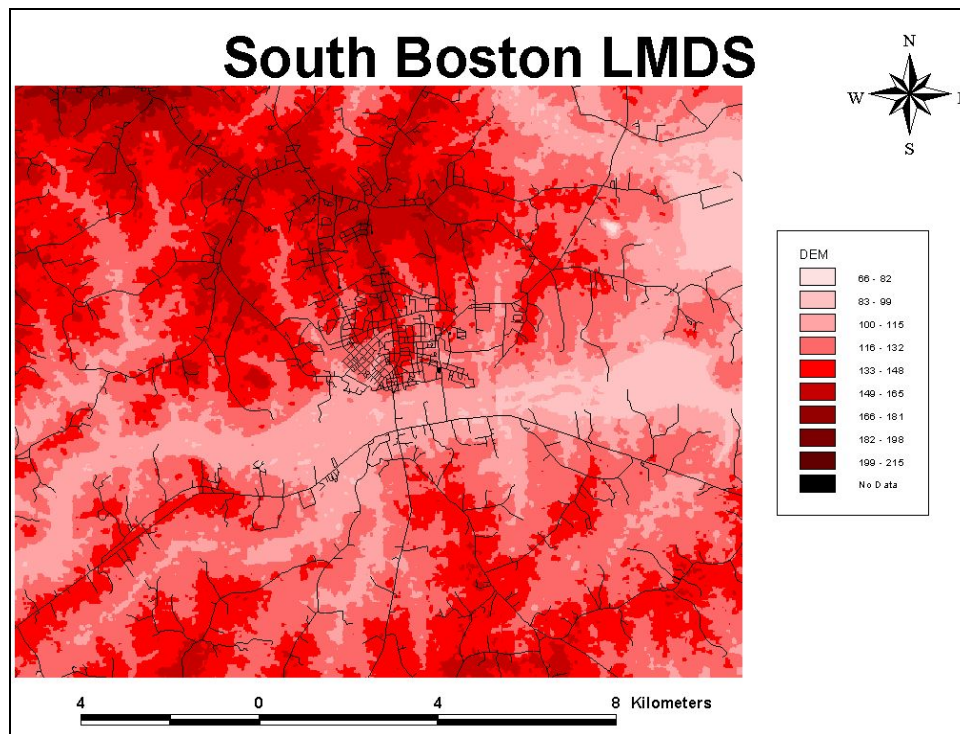

Figure 4.6 South Boston Digital Elevation Map (DEM)

Elevation in meters

4.7 Technical Design

Through our examination of various equipment vendors and the techniques implemented by their system, we have produced a deployment proposal for two types of LMDS deployment: Point-to-Multipoint (PMP) and Mesh. The following provides a technical design summary of the analysis done for both deployment methods.

Coverage Planning

From the start of this project, we had a few strategic primary customers such as AXA, CEC, and Riverstone Industrial Park to which we would provide the initial service. In this section we will examine different coverage schemes applied to the PMP and Mesh configurations based on distance and/or sector size. In order to accurately portray the real environment that an LMDS system will work in, we performed an in-depth analysis on the area of operation by measuring the actual line of sight (LOS) of the specific paths to our primary locations. This is done through what is called a “ViewShed”. To ensure optimum coverage, we performed numerous LOS measurements that took into account issues such as rain attenuation, diffraction, and the Fresnel zone criterion.

Viewshed Analysis

In order to determine the best location for a base station, existing potential sites are evaluated, such as existing tower locations, building roofs, and smokestacks. Once these potential hub locations are determined, a viewshed analysis is performed. A viewshed analysis determines what can be seen from a specified point to every other point within given parameters, such as tower and receiver height, beam distance, and beam width. The software used was ArcView 3.2 with the Spatial Analyst Extension. The Topologically Integrated Geographic Encoding and Referencing (TIGER) files were used for visual reference. This is an iterative process to determine optimal location for the base station. The primary customers for this project again are:

- Riverstone Industrial Park
- AXA-Berryhill
- Longwood College Continuing Education Center (CEC)

The secondary customers for this project are:

- Municipal offices
- Schools
- Hospital/physicians offices
- O'Sullivan
- ABB
- Dollar General

Another consideration in locating the tower includes providing for future expansion. We determined that the Highway 58 corridor and areas along Route 501 are important candidates for future expansion.

4.7.1 PMP (Point-to-Multipoint) system

The first major step in developing an optimal design for an LMDS PMP wireless network is to locate a Hub site that will provide the greatest coverage and link availability within a specific coverage area. The following demonstrates the procedures applied in the deployment analysis.

Potential Hub Locations

Taking all of these factors mentioned above into account, we determined that four possible locations could be effectively used as tower locations. These sites were:

- Smokestack on CEC
- Smokestack on Taylor Building
- A tower on Riverstone Site (to be constructed)
- Tower on East Hyco Road (American Tower Corp.)

CEC

The CEC was first considered because of its central location, on the south side of South Boston, where there would be virtually no limitation in terms of distance because the 3-mile radius limit would reach all primary and secondary customers comfortably (Figure 4.7).

However, the elevation of the smokestack on the CEC was not high enough for a signal to reach the AXA facility. In addition, building a tower on the roof of the CEC was considered too costly and impractical due to the height that would be necessary to reach the AXA facility. One considered solution to this problem was the addition of a repeater at the Riverstone site. This would essentially take the signal from the CEC and use a point-to-point system to reach the AXA facility. While this would work, it would add considerable cost to the project.

Taylor Building

The smokestack on the Taylor Building was also considered because it is centrally located, being several blocks from the CEC. Also, it sits on higher ground and the smokestack is taller. Even with these height improvements, the smokestack has the same problems that were experienced by the CEC location (Figure 4.8).

Riverstone

Riverstone was considered as a tower location for several reasons. First, there would be no cost to place our equipment in the park (assuming the transmitter would be placed on the roof of a building). Secondly, because this is one of our primary customers, the park would be covered. Most importantly, all three primary sites are covered from this location at 100 feet elevation above the ground level. (Figure 4.9)

There are several disadvantages to using the Riverstone site for the hub. The timeframe for building the facility is uncertain and may cause a delay in the implementation of the LMDS system. Secondly, its geographic location restricts it from reaching many secondary customers and future expansion is limited. Also, if no building were to be built in

the near future it would require the construction of a tower. While this has the potential to produce additional revenue (from selling other tower space), it will be an additional cost.

Tower on Southside Rt.58 (American Tower Corp.)

The Tower on East Hyco Road was considered because an existing tower (150 feet) is there now and a taller tower (195 feet) is planned to replace it near the beginning of the second quarter 2000. This tower has many advantages. First and foremost, it covers all of the primary customers (Figure 4.10). Secondly, it covers the majority of the secondary area and a large portion of future expansion areas. In addition, American Tower Corp. is willing to rent the tower space at 150 feet for \$400 per month.

The only downside to this location is that AXA is barely covered from this height. This means that a small structure might have to be built on AXA's rooftop in order to receive service.

Recommendation for Hub site

Our recommendation for the hub site location is the Tower proposed by American Tower Corp. on East Hyco Drive. It fulfills all of the requirements put forth and allows for the most expansion. In addition, this site seems to be the most cost effective.

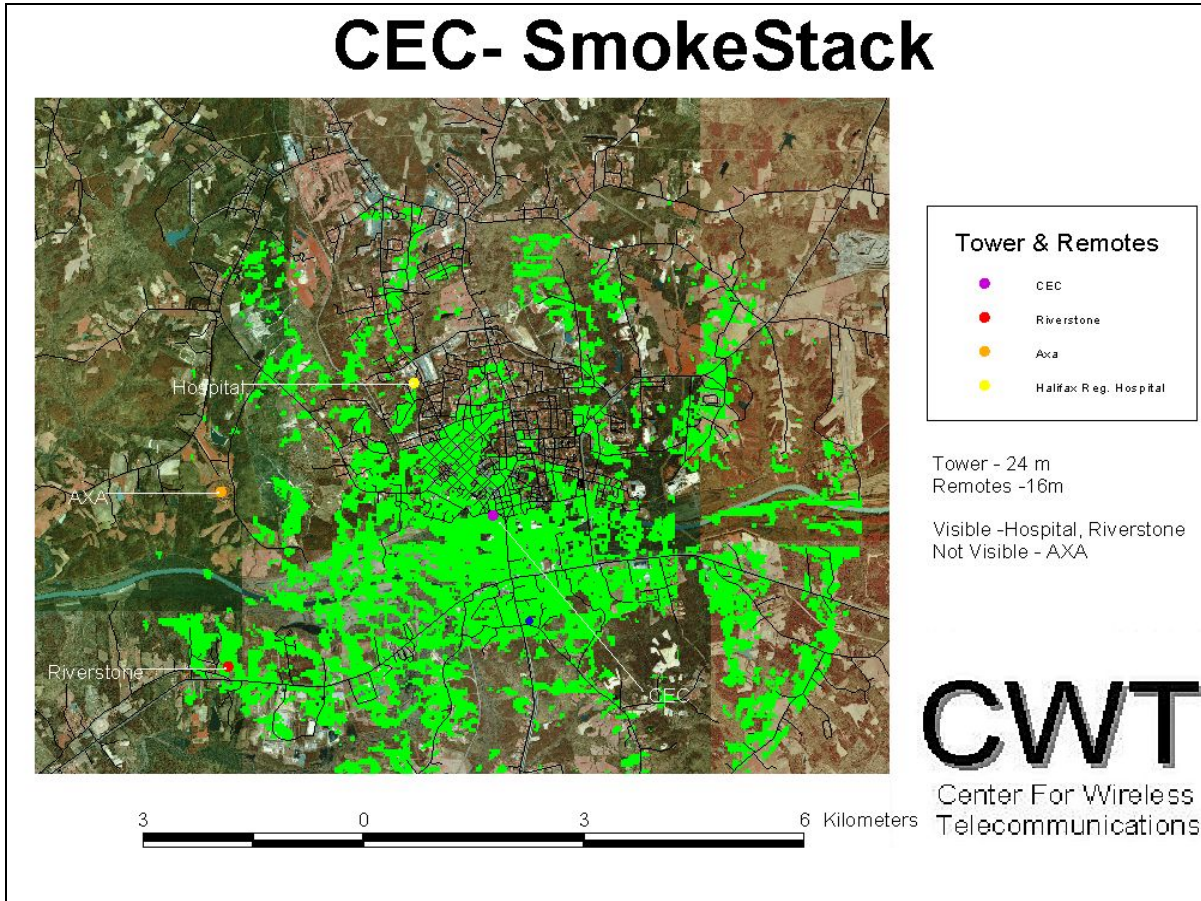

Figure 4.7 Longwood College Continuing Education Center (CEC)

*(The green area represents Line-of-Sight covered areas from the Hub, performed for 360°)

** (Each Figure illustrates both tower and remote heights (meter))

*** (Each Figure illustrates with primary customers are visible and not visible from the tower)

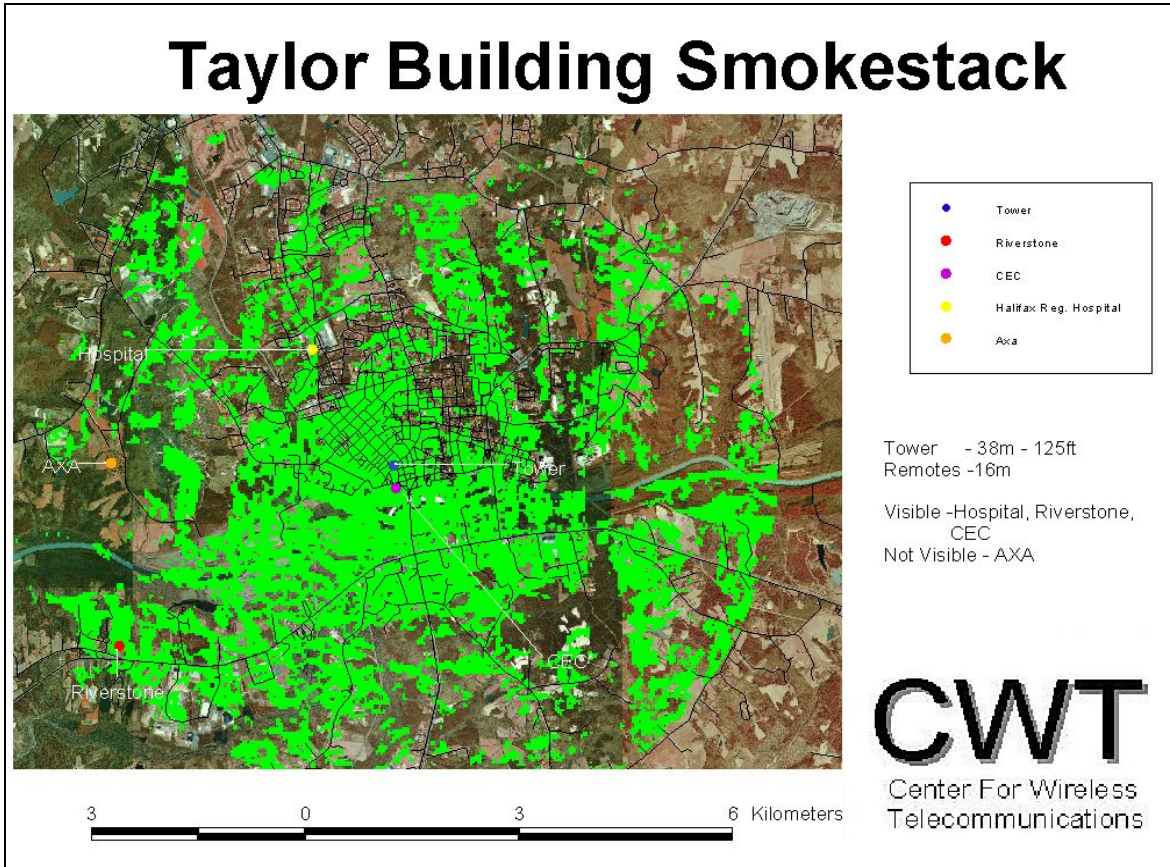

Figure 4.8 - Taylor Building Smoke Stack

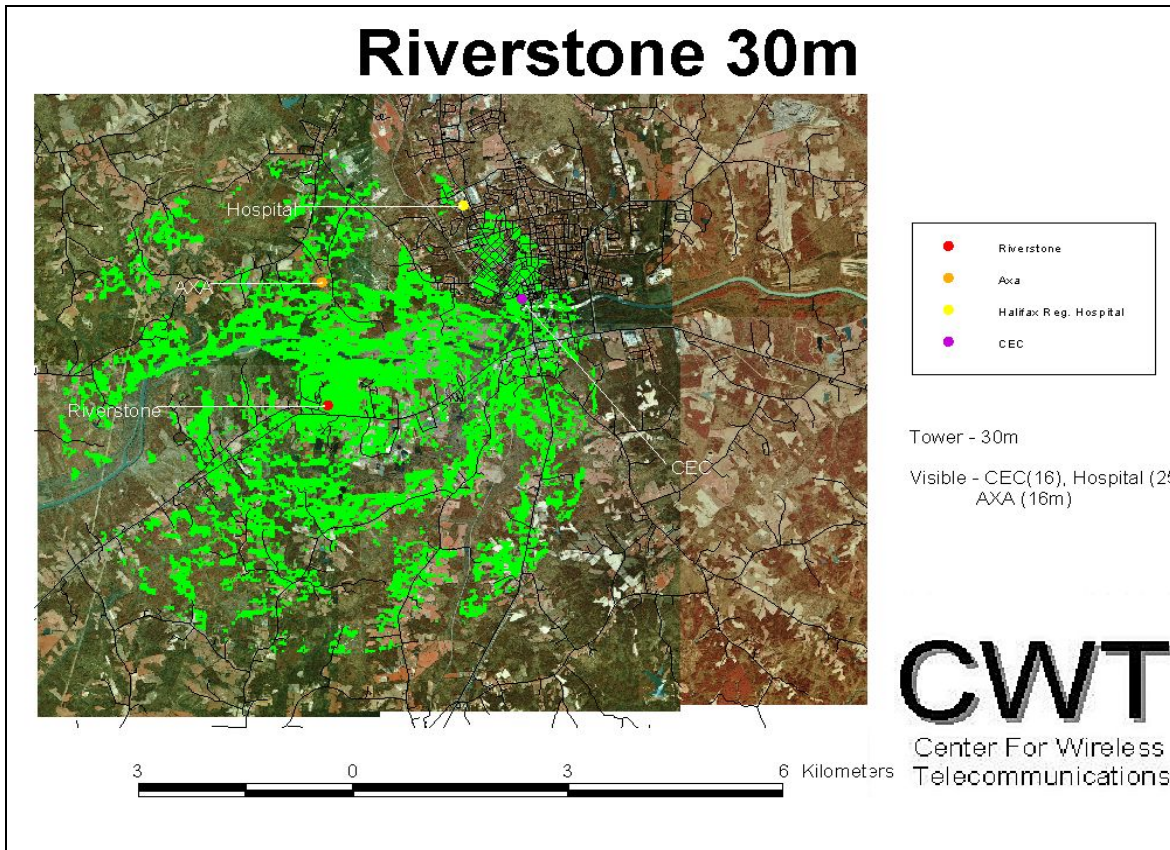

Figure 4.9 - Riverstone Business Park

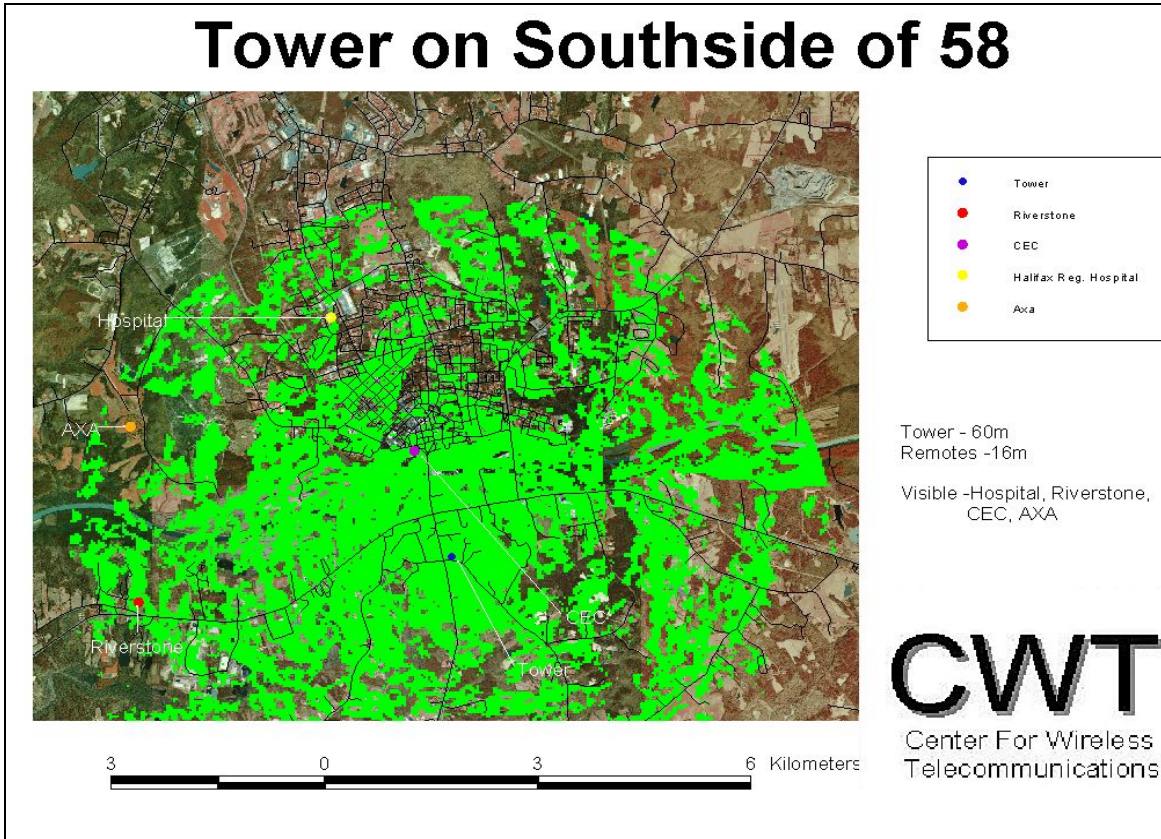

Figure 4.10 - Tower on Southside of Rt. 58 (American Tower Corp.)

Deployment Planning

With a defined Hub location, the next step is to develop the deployment plan that will ensure service to our customers. In this section, we will discuss in detail the location of the hub and each customer premise equipment (CPE) as well as the function that each will serve.

Hub

We have tower space at 150' on a communication tower (American Tower Corp.) as seen in Figure 4.11, located within town at the junction of highways 501 and 58. This gives us line of sight to all required remote sites. Currently, all proposed CPE sites are within 3 miles of the hub site. The hub should connect to the WAN via an OC3 or a DS3 ATM interface; other protocols and interfaces may be considered. A point to multipoint LMDS

network design is anticipated, though other designs will be considered. Long reach point-to-point solutions for links unreachable by a PMP system may also be considered.

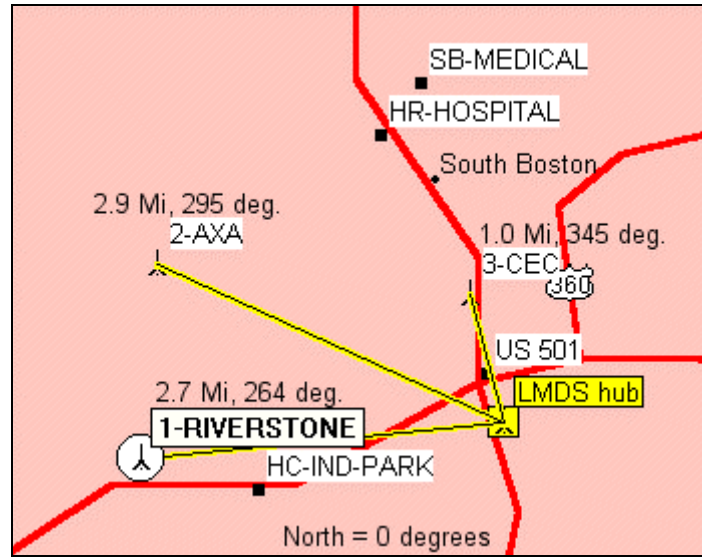

Figure 4.11 - PMP Hub site

Remotes

We will serve the initial 3 sites and expand as needed to other sites. Areas of expected expansion are west, along highway 58, possibly including sites in the Halifax County Industrial Park; and north, along highway 501, possibly including the Halifax Regional Hospital and associated medical centers. Bandwidth to expansion sites is undetermined, but is expected to be NxT1 initially, with the potential for future expansion/upgrades.

Riverstone Industrial Park (remote 1)

Riverstone is located approximately 2.7 miles from the hub at 264 degrees. We expect to initially serve the first building in the park with between 2 to 4 T1's (Ethernet may also be considered) with potential for future growth. The park is under construction and buildings will not be completed until after the LMDS network is first deployed. We expect to serve up to eight buildings upon their completion, but we must be capable of serving the site upon the LMDS network's deployment.

AXA Training Facility (remote 2)

AXA is located approximately 2.9 miles from the hub at 295 degrees. We expect to initially deliver 2 T1's or Ethernet, with potential for future growth.

Halifax County Continuing Education Center (remote 3)

The CEC is located approximately 1.0 mile from the hub at 345 degrees. We expect to deliver 2 T1's initially, with potential for future growth. Depending on the WAN configuration, DS3 connections may be desired to replace the site's existing wired DS3. Applications include broadband distance learning.

Based on this deployment planning, we have produced viewsheds from the Hub in sector beamwidths of several standard sizes: 30, 45, and 90 degrees. As discussed in Chapter 3.2, with a smaller beamwidth, more sectors are required to provide the same amount of coverage. This however, will provide greater transmission capacity to the users. These are illustrated in Figures 4.12, 4.13, and 4.14 respectively. The LOS validation was also performed for each primary link from the Hub to individual customers, as seen figures 4.15, 4.16, and 4.17.

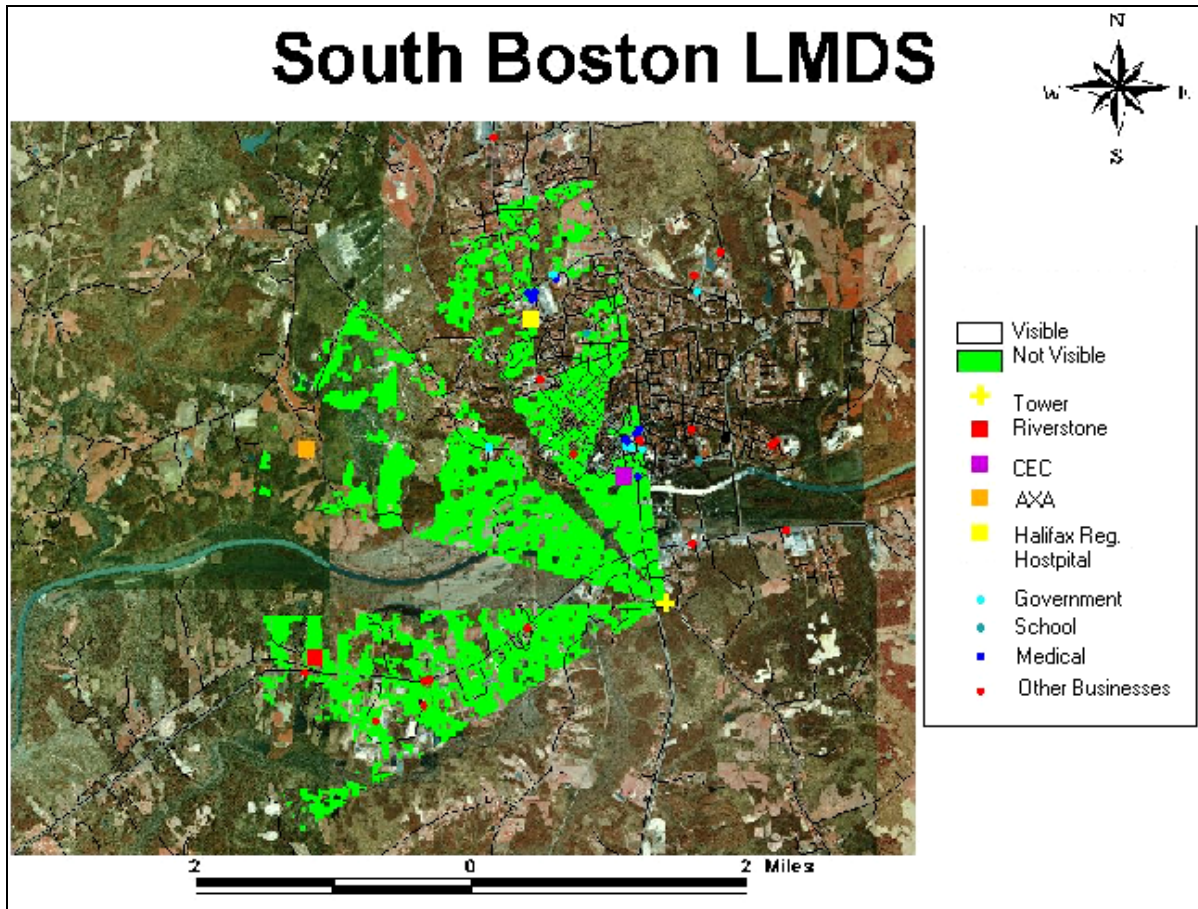

Figure 4.12 - 3-30 degree sector (American Tower Corporation)

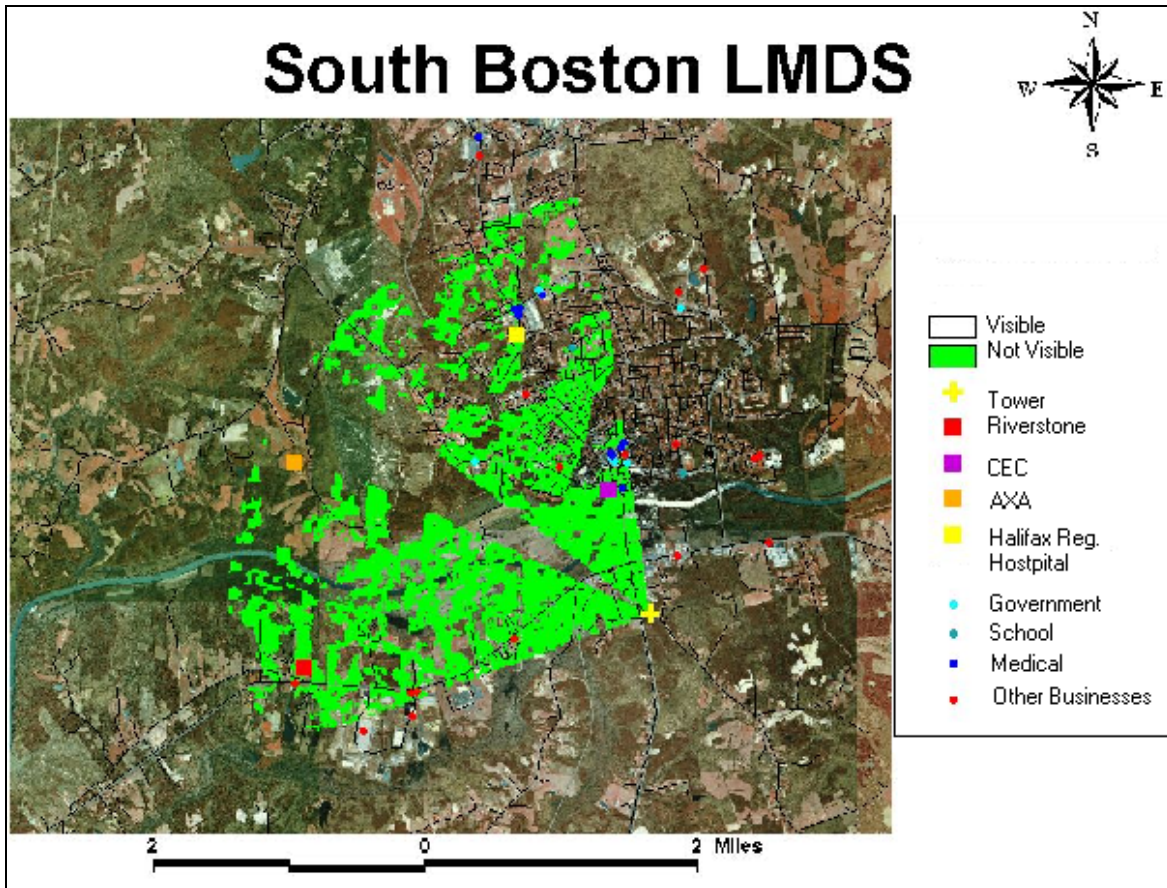

Figure 4.13 - 2- 45 degree sector (American Tower Corporation)

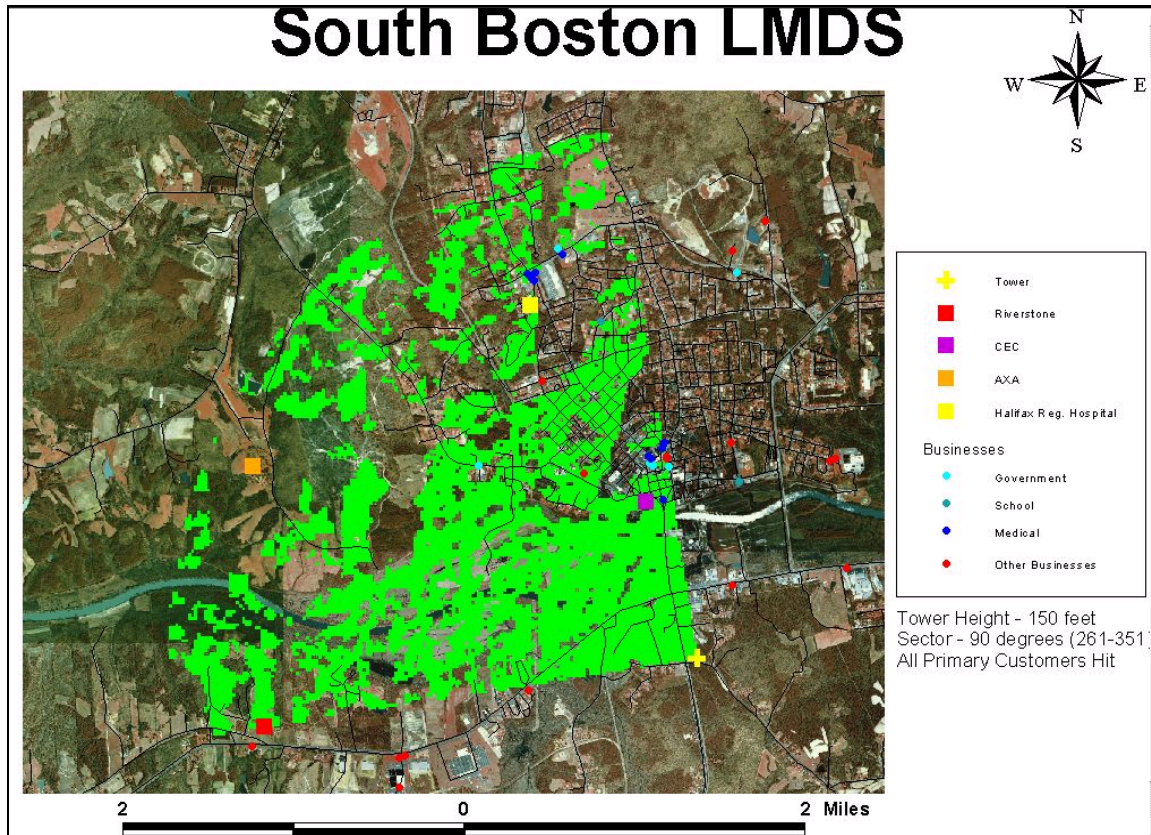

Figure 4.14- 1-90 degree sector (American Tower Corporation)

PMP design- LOS validation (Figures 4.15, 16, 17)

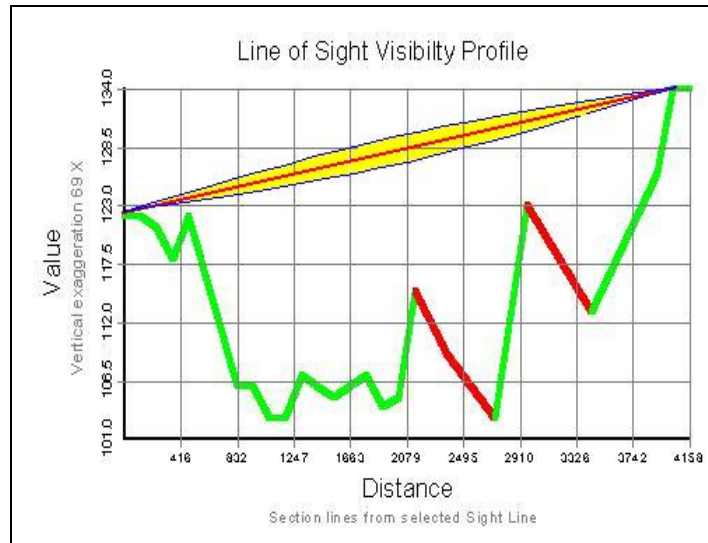

Figure 4.15 - LOS validation from tower to Riverstone

- *(LOS validation demonstrating a sample Fresnel Zone clearance: yellow shaded region)
- ** (Green topology represents visibility from Hub, Red shows no LOS to the particular area)
- *** (Main Concern is for the ends of the graph (Tx, Rx) to show LOS availability-green area)
- **** (All topology validations are exaggerated to allow full illustration from Hub to Remote)
- ***** (Validations based on flat earth model)

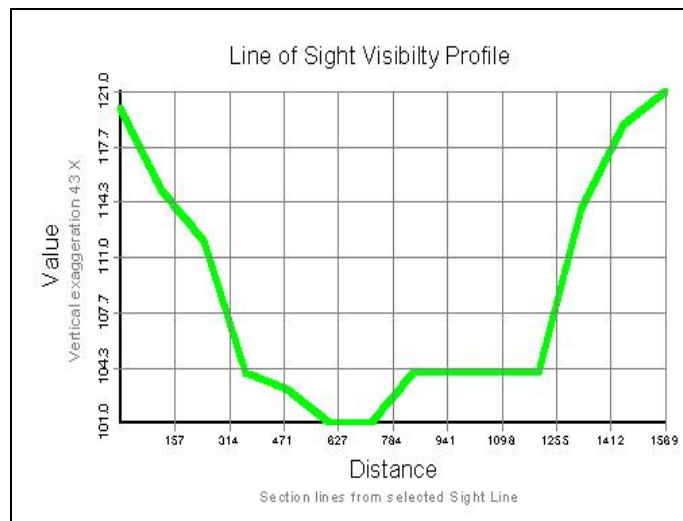

Figure 4.16 - LOS validation from tower to CEC

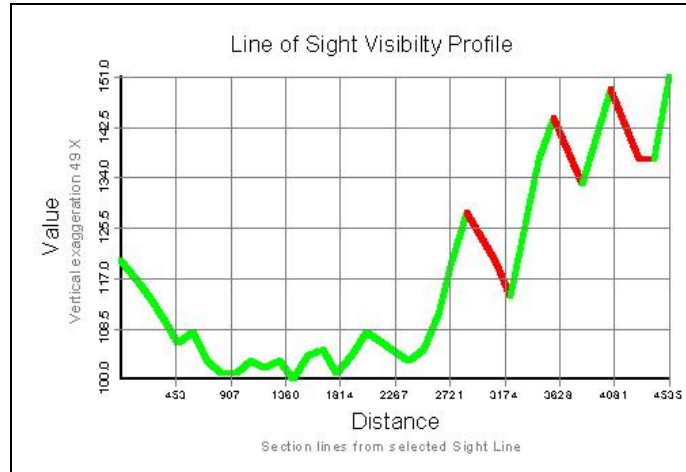

Figure 4.17 - LOS validation from tower to AXA

4.7.2 Mesh system

As described in the project proposal, the Mesh network faces several technical issues that will affect the performance of the overall system. In the following example, our engineering group has formulated a possible deployment scheme based on the Mesh architecture. The design incorporates one Trunk Network Connection Point (TNCP), one Mesh Insertion Point (MIP), and four Customer node (CN) modules. Again, this is a basic initial design and is only used to illustrate a possible minimum deployment scheme to provide the services required. As one can see from Figure 4.18 below, as well as the LOS validations in Figures 4.19 through 25, not all possible links will be available due to the lack of LOS.

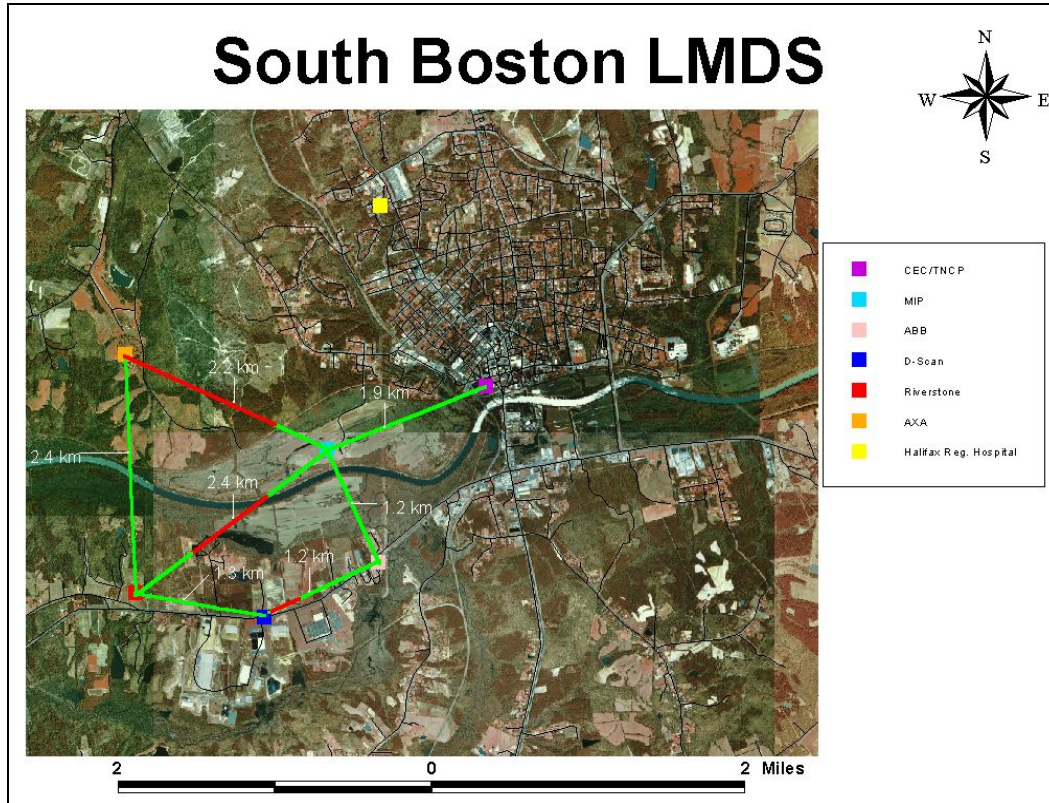

Figure 4.18 Mesh Network Proposed Layout

TNCP (Trunk Network Connection Point)

The location of the TNCP for this design will occur at the CEC building where there will be a T3 (45 Mbps) or an OC-3c (155 Mbps) WAN backbone access through VirginiaLink. This location was chosen for its accessibility to the nearby MIP node.

MIP (Mesh Insertion Point)

The Location of the MIP is chosen at an optimum location where the highest number of CN nodes will be within reach (± 2 km).

CN (Carrier Node)

The CN nodes are located at the desired customer sites. These include Riverstone, AXA, Halifax County Hospital, and another local business along the Route.58 corridor. As stated in the report, each customer can expect NxT1 (2~4Mbps) dedicated connectivity or up to 25 Mbps peak for variable bit rate service.

Mesh Design- LOS Validation (Figures 4.19 thru 4.25)

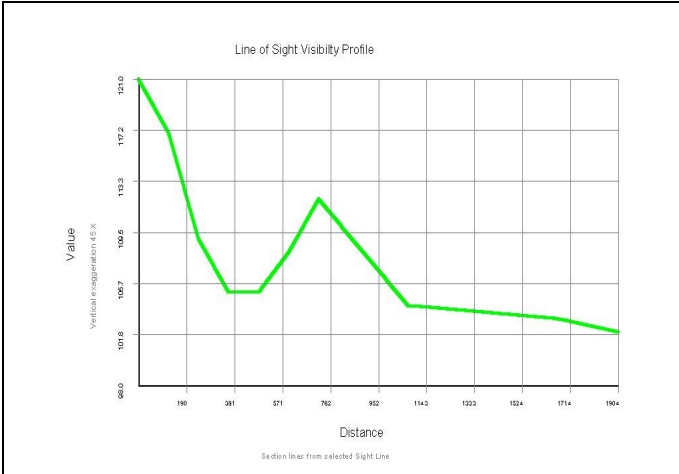

Figure 4.19: LOS validation from CEC/TNCP to MIP

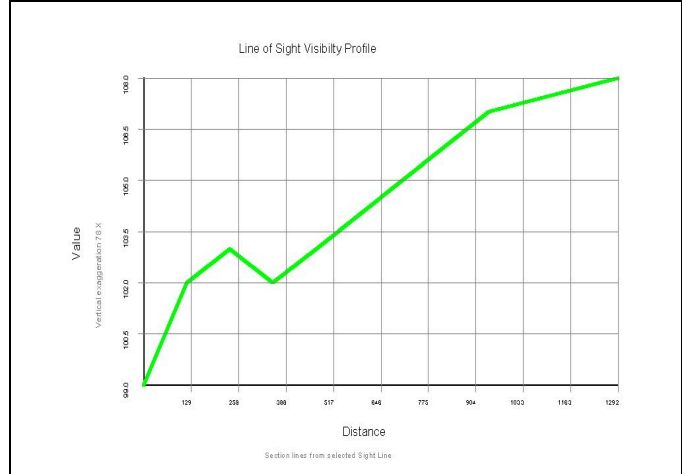

Figure 4.20: LOS validation from MIP to ABB

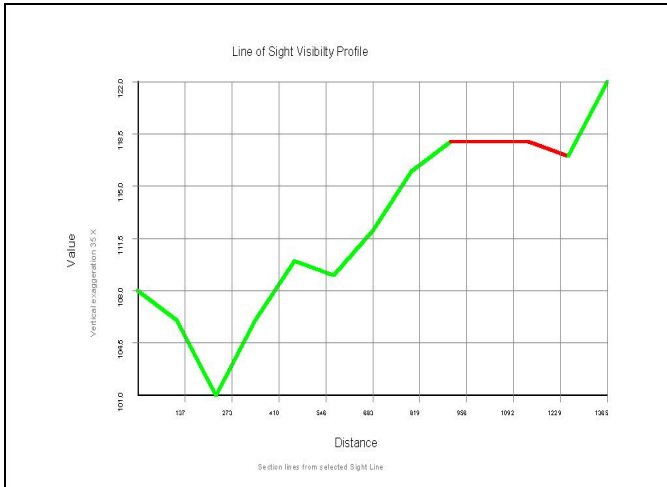

Figure 4.21: LOS validation from ABB to Dscan



Figure 4.22: LOS validation from Dscan to Riverstone

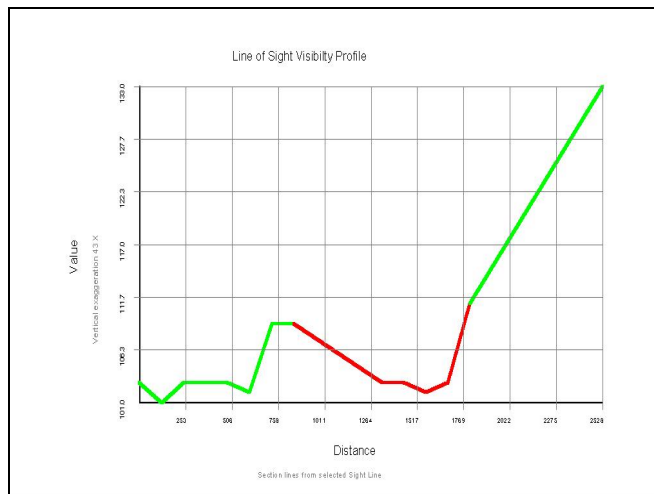

Figure 4.23: LOS validation from MIP to Riverstone

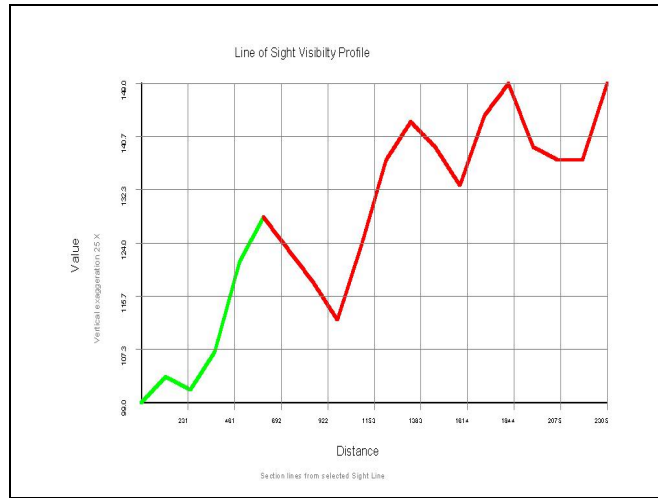

Figure 4.24: LOS validation from MIP to AXA (No LOS)

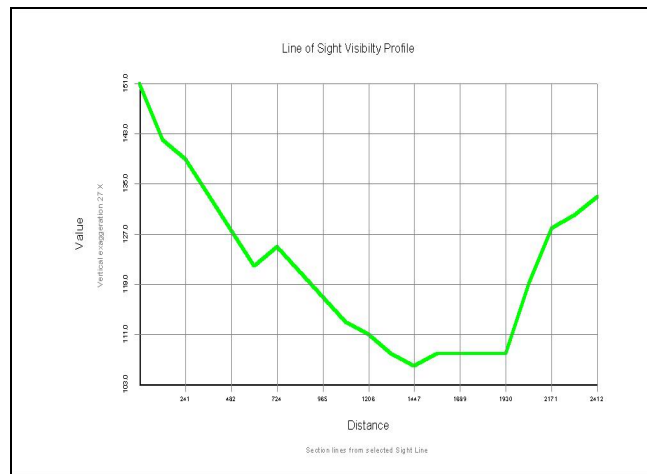

Figure 4.25: LOS validation from AXA to Riverstone

4.8 System performance/Link Budget

The following spreadsheets have been produced to evaluate the type of modulation scheme that will be most appropriate to fit the specified range of coverage and capacity for both PMP and Mesh networks. This calculation is based on the Friis equation, and it takes into account propagation losses due to specific attenuation (rain) and diffraction. In our evaluation, we are satisfied with the service only when the received signal meets the minimum required carrier-to-noise ratio for a BER (Bit Error Rate) of 10^{-6} after correction [29]. As you will find in the analysis, different modulation schemes will produce different

capacity and coverage based on the specific vendor. Illustrated below is one calculation performed based on equipment from a LMDS equipment provider. (Please see Tables 4.1 and 4.2)

Table 4.1 Link Budget A: PMP Longest Link- Hub to AXA

Specifications	
Path Length	4.32 km
Operating Frequency	28 GHz
Channel Bandwidth	8 MHz
Modulation	16 QAM
Multiple Access	FDMA
Azimuth Beamwidth	45°
Elevation Beamwidth	6°
Data Rate	20.6 Mbps
Exceedance Value	0.01 %
Rain Region	K (42mm/hr)
Polarization	Vertical

Link Budget: PMP		
Item	Value	Units
Transmitter Power (Pt)	19	dBm
Transmitting Antenna Gain (Gt)	17.7	dB
Receiving Antenna Gain (Gr)	36	dB
Receiver System Noise Figure (NF)	7.5	dB
Free Space Path Loss	134.11	dB
Free Space C/N	36.05	dB
Environment Attenuations	20.85	dB
Calculated C/N after Attenuation	15.20	dB
Allowable BER rate after FEC	10⁻⁶	FEC gain of ±6dB

The above link budget demonstrates the capabilities of the wireless link to allow the furthest connection (4.32 km) to operate with a maximum Bit Error rate of 10⁻⁶. The analysis done for South Boston county, accounts for an exceedance value of 0.01% or 99.99% reliability at rain region K. The Carrier-to-Noise showed a value of 15.20 dB after attenuation that will then be improved by approximately ±6dB using forward error correction. This makes the total C/N margin to equal 21 dB, which achieves the required BER of 10⁻⁶ as seen from Figure 3.15.

Table 4.2 Link Budget B: Mesh Network

Link Budget: Mesh Network (4.5° x 9° beam)			
	QPSK	QAM 16	QAM 64
TX power (dBm)	18.0	14.0	10.0
Antenna Gain (dB)	51.4	51.4	51.4
Radome Loss (dB)	-2	-2	-2
Fade and Implementation Margin (dB)	-3	-4	-5
RX Sensitivity (dB)	-81.1	-73.0	-65.7
Exceedance	0.01%	0.01%	0.01%
Implementation Loss (dB)	1	2	3
Maximum Allowable Path Loss (dB)	145.5	132.4	120.1
Maximum Range (32mm/hr rainfall)	2850m	1630m	766m

Due to the proprietary nature of the Mesh Network, more details were not included in this link budget. The chart above demonstrates the link availability in terms of distance and the modulation techniques used. The analysis performed was based on an exceedance value of 0.01% or 99.99% availability and rain region H.

4.9 Additional Design Concerns

Through this design process, there were various areas that required extra consideration. Due to the infancy of this technology, very little documentation has been produced in terms of actual deployment designs and processes. It is therefore valuable to compile and summarize the lessons learned through this experience for future evaluation as well as to enhance later deployments. The following factors played a major role in affecting the deployment strategies for the illustrated LMDS system.

Connectivity

- Backbone – This is a key issue where the determination of who will provide the WAN connectivity, how will it be connected to the Hub/TNCP site, and the connection cost for the respective speed will decide the access technology that will be available to the customer for Internet services.

- Connectivity to the customer – Understanding the proper technique in which the network will be connected to provide the user certain types of service (i.e. T1, Ethernet, PBX). This includes the evaluation of adding either a Switch or a Router to the system.
- LAN emulation/Circuit emulation – This is one issue that was not defined in the thesis thus far. Essentially this allows an ATM based network to appear as if has broadcast or multicast capabilities for LAN emulation and vice-versa for Circuit emulation. This is an issue that will be determined by the network designer based on the types of services (i.e. VoIP, Dedicated services) required.

Equipment

- Understanding the various components and their interactions with the network for various vendors is an essential part in deciding the correct equipment to purchase for the application of the LMDS system.
- Evaluating the pros and cons between each vendor (modulation technique used, total range, capacity, connectivity/service features) is also an important consideration.
- Differentiating between types of system such as PMP vs. Mesh. (i.e. PMP has a high initial cost for Hub construction while the Mesh will need a close cluster of customers for it to be effective in providing redundancy in the system) is also a step that needs to be taken.

Capacity Allocation

- Bandwidth allocation – Each vendor has its own system design that specifies the bandwidth allocated per channel/carrier/sector. Along with the tradeoff in selected modulation scheme and sector size, this information is important in determining the data rate capacities allowed.

Tradeoffs between cost and service

- Services offered, availability, and the cost for these services are questions that are fundamental to determining the business model. As the design engineer, one must be able to convey the level and types of services that the system can provide to the

business team. Services such as QoS for different levels of link accessibility, VoIP, and dedicated bandwidth for video conferencing are all areas that the engineer must be aware of.

- Tradeoff in increased cost for higher customer service levels such as bandwidth dedication
- Introduction of QoS in LMDS systems is still considered new and unstructured. In this thesis, QoS was defined in terms of conventional networking practice.
- Examining the tradeoffs in cost by increasing the number of beams to increase capacity.

Feasibility

- Is it worth deploying the system, will there be a profit?
- What competing technologies are there?
- How long will this system be effective before other technologies render it obsolete? (product life cycle)
- Perform market analysis to establish a viable business plan

Future Considerations

- Further expansion to tier two or three customers (lower priority, less capacity required clients) through the use of Wireless LAN is possible with the flexibility of the fixed broadband wireless system. Currently, studies for this expansion in deployment is being pursued for other locations. The application of MMDS (Multichannel Multipoint Distribution Service) and unlicensed wireless applications (UNII, 802.11) will allow further coverage from the CPE remote sites to other customers.

The experience gained from this analysis has resulted in much greater understanding of the deployment techniques for fixed broadband wireless systems. Through examining the design hurdles experienced in this project, this knowledge will increase the efficiency of future deployment campaigns and enhance the overall system quality.

4.10 Recommendation for System Architecture

In this proposal, we have provided an analysis for the City of South Boston using both PMP (Point-to-Multipoint) and Mesh architecture designs. From the demonstrated simulations, it is obvious that the coverage provided by the Mesh design would not work as well as a PMP system in this environment. Both the long distances between the selected nodes and the lack of LOS provided increased complexity that will result in a less efficient use of the Mesh system. With the deployment of a low number of nodes as is described in South Boston, the advantages of redundancy that a Mesh design could provide is unrealized. With the cost of both systems averaging around the same price range, it is our recommendation that a PMP system be chosen as the ideal deployment strategy for the City of South Boston. Attached to this document is a spreadsheet with equipment specifications for various broadband wireless system vendors (Appendix A).

Chapter 5

Business Strategy

Broadband wireless networking presents an alternative method of providing telecommunications service within a desired geographical area. Wireless networks can supply the technology to enable the provision of services to typically unserved or underserved customers. It may also lower the cost of providing service to customers, making the business case of deploying a network more attractive to network providers and customers. Although the technology currently exists to build many desirable features, costs can become restrictive. The key to a successful deployment is to find a balance between the two issues.

Wireless networks must be designed efficiently and effectively to provide a sound business case for the operation of the network. Services offered via a broadband network must be priced comparable to existing services to encourage customer migration and retention. The business case for each deployment will vary due to the many influences ranging from terrain to customer demands. In this section, we will illustrate some of the important issues in the Business sector that contributes to the successful design of such a network.

5.1 Exploring potential markets

To be successful, LMDS operators/vendors need to focus on the markets where there is a need for broadband services using packet/cell switched traffic for the merging of voice and data applications. The strength of LMDS is that there is no other technology that will allow rapid and economical deployment of new broadband services to small and medium-size businesses. As evident in many recent articles, many of the new broadband service providers,

whether wired or wireless, have been plagued by poor assessment of the targeted customers for their product [30].

For low customer densities, the suggested most cost-efficient access method is a Point-to-Point (PTP) microwave link. However, there is opportunity for broadband PMP systems to be the most efficient alternative where the requirements for peak data rates are 2 to 30 Mbps at the customer premise. The estimated break-even density between broadband PMP and PTP systems is about three to five customers per PMP sector carrier, depending on the required bandwidth [26]. Currently, the market only demonstrates profitability in areas of high customer density. Thus, in this thesis we have concentrated on the markets where LMDS will be used to provide coverage to a potentially large number of customers.

5.2 Equipment Costs/Vendors

Due to the competitive pricing nature of the LMDS equipment, we will not be able to discuss the exact cost for the equipment of any specific vendor in lieu of non-disclosure agreements. However, the average cost of a one-sector hub/base station is around \$150K, which includes network management capabilities, while each incremental remote/CPE will cost approximately \$10K. This pricing will fluctuate according to the operator's desires for possible features such as redundancy and improved quality.

Though there are numerous LMDS equipment vendors, we placed an emphasis on locating vendors that can provide the complete end-to-end wireless solution. This is an important factor to consider, especially if the service provider has limited experience with broadband wireless. By selecting a vendor that has a system with the complete solution, we can potentially avoid the problems of incompatibility that might arise while trying to integrate various components. To date, some of the vendors that provide complete end-to-end solutions are as follows:

- Adaptive Broadband – AB Access
- Alcatel/Newbridge Networks – Alcatel 7390

- Ensemble Communications – Fiberless 16000/300
- Ericsson – Mini-Link
- Harris/Wavetrace - Clearburst
- Nortel Networks – Reunion/Wireless Broadband
- P-Com - PMP
- Radiant – Radiant Mesh
- Siemens - Quickstream

5.3 Pricing Strategy

Based on a preliminary study done for the market, the key services that are most desired by customers are high-speed Internet access, video conferencing/streaming video, and electronic data exchange. It would be the operator's task to provide these services at a price that would be less than, or at least comparable to, competing technologies such as fiber or xDSL. In the example of South Boston, we found that the cost of providing a T1 connection to a customer would not be profitable because of competition from the special pricing of wired connectivity by Virginia Link. However, the business case will show positive margins if we were able to sell higher connectivity rates to customers. This issue does not have a set parameter to which the pricing is determined. The strategy will vary according to the availability of alternative technologies, pricing of backbone connectivity, number of customers, and the desired level of service by the customer.

5.4 Application of Business Strategy to Case Study

In this section we will use the South Boston design project to illustrate the issues discussed earlier [27].

Financial Model

To achieve the objective of identifying the size of market needed to support a profitable business, we experimented with different growth rates, the number of initial customers, and the configuration of service offerings. Our assumptions about costs and customer responses are based on the best available information at the time of the modeling. Equipment expenses in particular have been difficult to gauge as they have been falling and

will continue to fall as more service providers deploy. We incorporated a drop in the cost of equipment as a “negative growth rate.”

To access the market needs, we conducted both telephone and mail surveys for the region. Based on survey results and contacts with businesses, we identified a likely base of customers and their needs for high-speed communications services. The financial analysis assumes that the investors require a 20% rate of return to justify taking the risks of entering the venture. Thus a positive value added (“net present value” or NPV) indicates that the investors receive a return beyond the 20%.

The “bottom line” of the financial analysis is an estimate of probability that the value of the enterprise is positive (or alternatively the risk that it will not be positive). This probability is a function of the average level of the cash flows that will be generated as well as the extent of the uncertainty about the customer demand and other parameters. Shown in Figure 5.50 is the NPV simulation performed for South Boston, performed by MBA student, Markus Kalalahti, using Monte Carlo simulation. The analysis calculated an average normal distribution for the probability that the NPV will be less than \$0 to be 18% (or the probability that a positive NPV value will result is 82%). This result demonstrates that the business scenario for South Boston will have a good chance in generating positive revenue for profit.

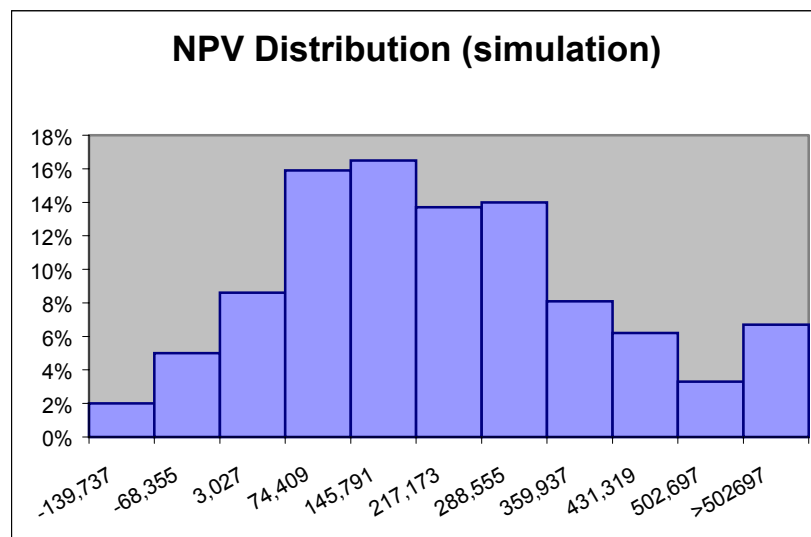

Figure 5.50 NPV distribution for South Boston [27]

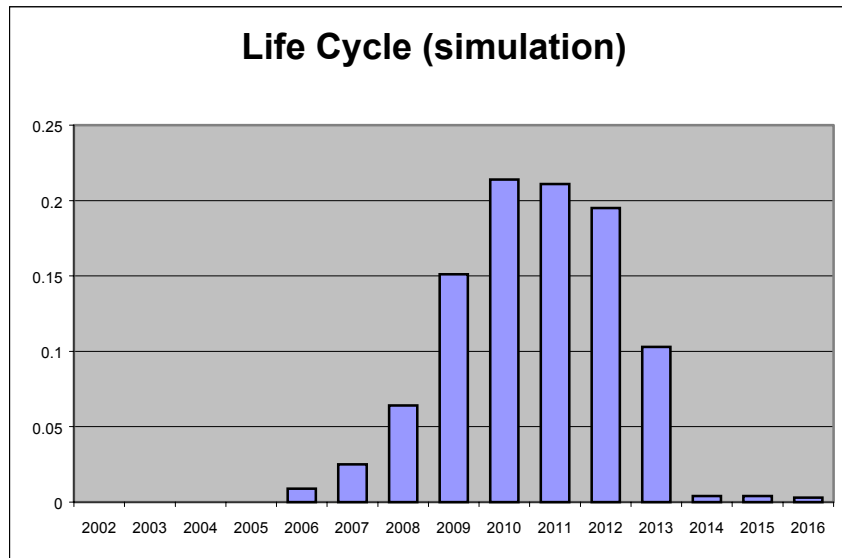

Figure 5.51 Life cycle probability for the LMDS system in South Boston [27]

Figure 5.51 shows the life cycle probability of the LMDS system designed for South Boston. This graph describes the time frame of the probability that the system will start to incur negative NPV values that will result in an unprofitable business case. As seen in the figure, the predicted profitable life cycle of the LMDS system ranges from year 2002 through 2009 or 2010. The factors that affect this decline in profitability include drops in the price of service to the customer, competition from new technologies, and customer growth. These factors are based on previous technology life cycle trends. The time frame of the system life cycle will change if the network is continually updated to compete with incoming technologies.

Business Plan

Services offered (based on preliminary study of the market)

- High speed internet access
- Video conferencing
- Electronic data exchange
- VoIP

Initial customer base

South Boston appears to have an excellent customer base for the types of services that a high speed fixed wireless system can offer. Our research identified strong needs in manufacturing, health care, and education.

AXA

The AXA facility desires substantially faster service than currently available to them at a reasonable price. We believe that appropriate configurations of the wireless system could meet their needs. (Note: the financial model does not explicitly incorporate any additional expenses needed to serve AXA, such as tower space lease payments, construction of mounting hardware on structures, or laying fiber from the nearby tower to the AXA building)

CEC- Longwood College

While we note that the CEC has a strong interest in high-speed access, it will not itself be a user unless linked to someone else. This is because CEC will already have a Network Virginia connection. Although the plan is to operate at moderate speeds, a higher speed connection could be installed. Thus, a wireless connection is not of value unless the wireless capability connects the CEC with some local user who might not have easy access. Thus it is important that other users of CEC services be identified in order to justify making the wireless service work for the CEC. Possible users include: Longwood College, Riverstone companies, other business parks, and agencies. In addition, Longwood College could serve as service provider in the sense of leasing capacity to commercial users if it acquired Virginia Link service instead of Network Virginia service.

Riverstone Industrial Park

We anticipate that a high-speed communications connection will be crucial for attracting tenants to the Riverstone Park. However, it is clear that such tenants are not currently (2001) in place and so cannot be a source of revenue supporting the deployment in the initial phase. The technology must be deployed in a fashion that allows for an easy

extension to the Park as soon as a customer arrives there. Thus others are critical for the initial stage.

Secondary Customers - ABB, O'Sullivan, Dollar General, Halifax Regional Hospital, public safety agencies, publishing and printing.

Halifax Hospital and surrounding health care facilities

We believe that a significant customer for the services is the health care market centered around the hospital in South Boston. Although the health care community may not be in the initial customer rollout, the opportunities to link physicians, radiologists, nursing facilities and others to the hospital is attractive. The hospital was considered as a hub, but because of its location relative to Riverstone, its desirability was decreased. However, if the hospital could be a partner as well as customer, an initial deployment could incorporate services to the hospital with plans for expansion in the second phase.

Expandability beyond the initial corporate customer base is very important to financial success (and therefore to acquiring initial investors/partners), and the initial deployment therefore needs to provide the flexibility to do this quickly and cheaply. This is particularly important to bringing Riverstone Park tenants on-stream

Pricing strategy

There appear to be two choices in pricing. The first is undesirable while the second appears profitable.

- Option 1 - 1.55Mbps connectivity at below \$1000 (where it is not profitable) we have \$1000 in our model with 6 customers.

Service priced at \$1000/month or slightly higher for 1.55Mbps service is not competitive because, in principle, Virginia Link is already advertising this price for a wired connection

anywhere in the state. However, it seems likely that this is not profitable for Virginia Link either. Similar to wired networks, it is evident that the cost of providing connectivity to sparsely located customers who only required lower data rates will not result in an economically sound business plan [28].

- Option 2 - Substantially higher speed connectivity bundles of 10Mbps-\$2500 or 25 Mbps-\$3500 (or higher for higher speed or guaranteed quality of service) per month level.

Because the copper plant in South Boston is not believed to be sufficient to support DSL and thus competition for higher speed service is not likely to come from DSL providers, there is an opportunity for wireless service at the higher speeds. Option 2 is assumed to be the better long run strategy with the cost of the bundled service priced with a significant edge over that of Virginia Link. However, the adoption of this strategy does require initially offering some customers connectivity rates of 1.55Mbps at a slightly lower price than Virginia Link. These lower speed offerings may be viewed as opportunities for customers to experiment with the service before upgrading to the higher speeds. The service provider should plan on offering such service at a loss in order to capture the longer run, upgraded service to these customers at a more profitable level.

Partners/Operators

In choosing partners, it will be important to consider possible synergies with the partner's existing business. The financial model assumes that the costs of operating can be kept to a reasonable level by virtue of "sharing" of resources with other projects. Customer service, in particular, is an area that is not a constant demand on the time of technicians, or at least would not be expected to be so with the small number of customers assumed here. Thus a partner who has a customer service staff that can turn to serving other customers during periods when the LMDS customers are not experiencing problems would be a good choice. Alternatively the partner could be involved in LMDS deployments elsewhere and be able to shift resources between different deployments. The financial model does not assume a stand-

alone commercial entity for the purpose of allocating resource costs, i.e. synergies with other business areas are assumed.

Deployment Plans

First Phase deployment (first year)

We intend to start with a reasonable number of customers (initially five buildings to ten by year end) to acquire sufficient positive cash flows from higher speed service and “capture” lower speed customers who will upgrade later. By providing quality service and avoiding the negative marketing effects of poor service, this will generate positive word of mouth advertising in this close-knit community. This initial deployment will also allow the service provider to get experience with the technology and the market as well as developing the market, the customer expectations, demand, and applications for this service.

Second Phase - wider commercial operations

The initial phase should serve to provide experience with the equipment as well as create a presence and visibility in the community. Once the technology is proven in the field, a wider appeal to businesses can be undertaken. Initial customers can provide testimonials regarding the service and its costs. Also, new applications should become apparent as a result of the initial customer usage, this should springboard additional value propositions in a second phase of the deployment.

We anticipate that the Riverstone Park tenants will begin to enter the system during this second phase and thus generate an important source of revenue for the service provider. Growth is assumed to provide a 50% increase each year in the number of customers. As time passes, we expect customers to shift from T1 service to higher speed services. Thus although there is little profit in providing T1 service, upgrades to higher speed services do become profitable. Small home offices as well as additional manufacturing, health care, and governmental customers are envisioned in this phase.

It should be noted that the financial model caps the number of customers at a maximum of 80 (industry, schools, municipal offices, government) users (the results are relatively insensitive to this constraint between 70-100 users). It is possible that a successful initial phase will actually produce demand from more customers than reflected in the model, but we have chosen to be conservative in our estimates.

Third Phase - residential service (not included in financial model)

Once the technology is demonstrated in a business setting, we believe the significant value proposition is in residential service within the system's footprint. This will require substantially cheaper equipment than is now (early 2001) available. However, Virginia Tech is developing technologies that would meet the cost and service requirements and these innovations could be available for market deployment within several years. Even without additional innovations, we expect the cost of equipment to decline rather dramatically and certainly become feasible for residential customers in closely clustered neighborhoods and with high demand for services to the home.

Business Structure

Partnering Arrangements (advantages and disadvantages)

The choice of the technology to deploy will influence the types of partners that are required. As the level of complexity and novelty of the technology increases, it is more important that partners have the ability to cope with the experimental and learning-by-doing aspects of a deployment.

- Sprint

As the provider of Virginia Link tariffed high speed wired service, Sprint could be a natural partner. The wireless framework could extend their capabilities to a wide number of dispersed customers at a lower deployment cost. By opening the market to customers who

otherwise might not perceive high speed service as financially viable, the wireless system can increase Sprint's revenues while holding down costs. The expansion of the available market would continue especially beyond the initial phase of deployment. Sprint would have to be convinced that this is an opportunity rather than a threat to their business. One must be wary that they, or other partners, might view the technology as a threat (though they would not admit it to outsiders) and that they could masquerade as a willing partner only to thwart and stall the wireless deployment.

- Local ISP

A local ISP could be an excellent choice for a partner. Being a local entity that is interested in providing services to customers, the ISP would not necessarily have a competing interest, but rather a complementary interest in exploiting wireless technologies. An ISP with sufficient technical background in telecommunications infrastructure could provide valuable "on the ground" service for installation, customer service, billing and other business services and interactions with customers. However, the ISP partner who is taking the lead role in interfacing with customers needs to have a high level of expertise. An inept partner in this role would be fatal to the project.

- Others

Other entities could prove to be valuable partners. The Hospital, for example, has expertise in telecommunications that could be fruitfully applied if they were interested in making the investment in developing the broader telecommunications business. Longwood College, as mentioned above, could also perform as a reseller and partner. Similarly some of the manufacturing firms in the area could provide expertise in the place of Sprint or an ISP partner. Use of these other partners to the exclusion of a local ISP or Sprint needs to be managed very carefully to ensure adequate skills and sufficient commitment to the success of the venture as an independent business.

Conclusion of Financial Analyses

Profitability

As mentioned earlier, we use the value created by the new venture as the main criterion. The project can be significantly value additive under the assumptions made with an 80% profitability of value added beyond the assumed 20% required return on investment.

Size needed

- The market in the initial phase needs to be roughly 10-15 customers
- Growth in the customers taking the service needs to be relatively rapid after the first year at roughly 50-60% (rates of growth this high would not be unusual for a start up company in its first several years)
- Growth in the fourth year and beyond has been assumed to be 20-30%
- In 5 years, a profitable business requires that the number of customers needs to have grown on the order of:
 - 1.5 Mbps: 24
 - 10Mbps: 24
 - 25 Mbps: 6

Needed investment

Using data available to us at this time and including working capital needs, roughly \$400,000-\$500,000 would be needed in the first year of a commercial business.

Likelihood for success is relatively high

- The probability of a negative value arising appears to be on the order of 20%
- This suggests a manageable risk given that the returns could be considerable

- Within the cases of negative value, the financial modeling incorporates the “option” to abandon the technology in a future year if it appears that continuing will only result in greater losses
- The modeling does not take into account the potential to divert the technology to other unforeseen uses nor the opportunity to learn from the experience and apply that learning to alternative methods of serving the community. These are “options” that could add considerable value to the project but have not been included in the reported numbers.
- Thus, we believe that with the right choices, partners will gain and create value for participating in the venture. This should attract partners and ensure continuing efforts to exploit the value of the technology.

5.5 Conclusion of Financial Analysis

From the topics mentioned above, it is easy to see the necessity of close interaction between the disciplines involved in an LMDS network design. The profitability of the system depends on an intelligent layout and design of the wireless network. By exploring the potential market, the operator will determine the feasibility of deploying an LMDS system in the desired geographic location. Through analyzing the cost of the network equipment that will be required to serve the potential customers, a pricing strategy is then formulated. The success of each deployment is never guaranteed. However, with solid business planning and a little ingenuity, the rewards of braving the initial challenges facing this growing market might be significant.

Chapter 6

Conclusion

It has been almost two years since the auctioning of LMDS licenses by the FCC. Yet, not much has been done in terms of commercial deployments in the United States. Without a doubt, the service possibilities that an LMDS technology can offer are quite significant. The difficulty lies in the willingness of the spectrum holders to break new ground and be a pioneer in this emerging market. Due to the lack of standardization, most of the license holders are playing a “wait and see” tactic to evaluate what the major operators will do and the types of integration service they will offer. Many of the companies are still trying to put together a business plan that will result in a profitable application of this new technology. Observing the need to clarify issues surrounding the deployment of LMDS, this thesis was developed.

Through this paper, we have examined the factors that affect deployment strategies for an LMDS system in a rural environment. To provide a better understanding of this technology, we have provided a review on the background issues in the areas of terrain, coverage/capacity, and networking. By evaluating these criteria, we have generated a strategy that can be employed to facilitate the application of LMDS. In Chapter 5, we then demonstrated these methodologies on a case study of South Boston.

By applying the deployment strategies to the network design of South Boston, we have concluded that the PMP system would be the best choice for the specified customer base and geographic layout. We further explained the importance of the integration between disciplines of geography, engineering, and business. As mentioned before, LMDS is a developing market that is always evolving to provide better and more efficient service. The major operators and providers of this arena will determine the shaping of this market.

The South Boston/Halifax County design project provided an example that demonstrates benefits from the implementation of high-performance, high-bandwidth networks. The area has an abundance of workers that potentially could find employment in low-end IT jobs in the near future. Additionally, as the education and training improves across the Commonwealth, many of these workers will transition to higher-wage positions in high-end IT jobs and careers. The proposed LMDS system will be poised to be an immediate gateway for these technological services.

Through this thesis, we have provided the information necessary to develop an intelligent and effective design of a LMDS system. With still many challenges ahead for this young industry, it will be an exciting time to see the deployments of these broadband wireless networks as the market matures.

References

- [1] “Illustration of an LMDS network”, <http://www.webproforum.com>
- [2] Peter Tenerelli, “Diffraction by Building Corners at 28 GHz,” M.S. Thesis, ECPE Department, Virginia Tech, Blacksburg, VA, June 1998.
- [3] T.S. Rappaport, *Wireless Communications: Principles and Practice*, New Jersey: PrenticeHall Inc., 1996.
- [4] Lee, W.C.Y., *Mobile Communications Engineering*, McGraw Hill Publications, New York, 1985.
- [5] Roger Freeman, *Reference Manual for Telecommunications engineering*, 2nd edition, John Wiley & Sons, Inc. 1994, pg.762.
- [6] Rec. ITU-R PN.837-1, “Characteristics of Precipitation Modeling.”, International Telecommunications Union, Radiocommunications Assembly, Geneva, Switzerland, 1997.
- [7] Rec. ITU-R P.838, “Specific Attenuation Model for Rain Use in Prediction Methods.”, International Telecommunications Union, Radiocommunications Assembly, Geneva, Switzerland, 1997.
- [8] Rec. ITU-R P.530-7, “Propagation Data and Prediction Methods Required for the Design of Terrestrial Line-of-Sight Systems.”, International Telecommunications Union, Radiocommunications Assembly, Geneva, Switzerland, 1997.
- [9] Majeed, Mohamed and Tjuata, Saibun, “An Improved Propagation Model for Wireless Communications.”, *1995 IEEE International Conference on Communications. Converging Technologies for Tomorrow’s Applications. ICC96.*
- [10] Seville, A., “Vegetation Attenuation: Modeling and Measurements at Millimetric Frequencies”, 10th International Conference on Antennas and Propagation (Conf.Publ.No.436).
- [11] Al-Nuaimi, M.O. and Stephens, R.B.L, “Measurements and Prediction Model Optimization for Signal Attenuation in Vegetation Media at Centimeter Wave Frequencies.”, *IEE Proc.-Microw. Antennas Propag.*, Vol. 145, No. 3, June 1998.
- [12] A. Seville and K.H. Craig, “Semi-empirical model for millimeter-wave vegetation attenuation rates.”, *IEE Electronics Letters Online NI: 19951000*, 5 July 1995.

- [13] N.E. Daly, T.C. Tozer, D.A. J. Pearce, D. Grace, A.G. Burr., “Capacity Effects on Terrestrial Broadband Wireless Access Networks, Operating in the LMDS Frequency Band, During Rainfall conditions.” IEEE, 2000, 0-7803-5718-3.
- [14] “ComparisonShopping”,
http://www.americasnetwork.com/issues/99supplements/990601lmds/990601_compare.htm
- [15] “PMP in the metro market”,
http://www.americasnetwork.com/issues/99supplements/990601lmds/990601_pmp.htm
- [16] Djuradj Budimir, Bratislav Milovanovic and Vladan Stankovic, “Broadband Wireless Systems and Components-An Overview,” Telsiks’99 IEEE 1999
- [17] Snow A.P., Varshney U., Malloy A., “Reliability and Survivability of Wireless and Mobile Networks”, IEEE July 2000, 0018-9162.
- [18] “Error Rates for PSK and QAM Systems”,
<http://www.cisco.com/warp/public/cc/pd/witc/wt2700>
- [19] Couch, Leon W., *Digital and Analog Communication Systems* 5th Edition, Prentice-Hall, Inc., Upper Saddle River, NJ 1997.
- [20] Douglas Gray, “Optimal Hub deployment for 28GHz LMDS Systems,” Wireless Communications Conference 1997.
- [21] Mehler M. “Planning Local Access Millimeter wave systems” IEEE 1991 ICC’91 pg. 1191.
- [22] OSI Network Layers,
http://www.techedcon.com/refguide/The_OSI_Reference_Model.htm
- [23] ATM Service Class Associations,
<http://www.cs.virginia.edu/~cs457/slides/Protocol-Architecture/sld037.htm>
- [24] Larry Peterson, Bruce Davie, “Computer Networks: A Systems Approach 2nd Edition,” Morgan Kauffman Publishers.
- [25] LMDS cell design, <http://www.cis.ohio-state.edu/~jain/cis788-99/lmds/>
- [26] “Targeting Your Markets,”
http://www.americasnetwork.com/issues/99supplements/990601lmds/990601_target.htm
- [27] Reference: South Boston Project Report

- [28] "OUTFRONT," Forbes magazine, April 30, 2001 pg.52.
- [29] EE5656 Communications System Design II, Dr. Timothy Pratt
- [30] "Extreme Entrepreneurship," Wall Street Journal, Thursday, April 19, 2001, C1.
- [31] Hairuo Ma, Magda El Zarki, "Broadcast/Multicast MPEG-2 Video over Broadband Fixed Wireless Access Networks" IEEE Network, pg.80, Nov/Dec. 1998.
- [32] Advantages of LMDS, <http://www.worldcomms.com>
- [33] Agne Nordbotten, "LMDS Systems and their Application", IEEE Communications Magazine, pg.150, June 2000.
- [34] Mesh network, <http://www.radiantnetworks.com>
- [35] T. Fowler: Mesh networks for broadband access, IEE review vol.47 No.1 January 2001, pg.17-22.
- [36] Agne Nordbotten, "LMDS systems and their applications," IEEE communications magazine, June 2000, pg. 150.
- [37] Douglas A. Gray "A Broadband Wireless Access System at 28 GHz", *Wireless Communications Conference 1997*, Proceedings, pg.1-7

Michael D. Lei

(Vita)

Born in Taipei, Taiwan. Michael has had the opportunity to experience and learn the culture of the orient. At the age of eight, the course of his life made a drastic change when his family immigrated to the United States. The meeting between the East and West has given Michael the ability to appreciate qualities from both cultures.

As a young boy, Michael has always enjoyed creating and designing new and sometimes abstract forms of machinery, mostly transportation objects. Through his grade school years, he has demonstrated the ability to excel in areas where analytical thinking is required. During his undergraduate years at Pennsylvania State University he majored in electrical engineering, specializing in wireless communications.

While at Penn State, Michael had the opportunity to intern at Bell Atlantic Mobile, NJ where he was exposed to the growing world of cellular communications technology. During this experience of performing call analysis, cell site deployment, and learning about the wireless system in general, he found his interest in becoming a systems engineer for the wireless industry. After graduation, Michael also worked as a Design Engineer for Lockheed Martin Missile and Space in Newtown, PA. After his exposure to many of the brilliant minds in the industry, Michael felt a need to further his education in order to become a leader in the wireless market.

Noticing the excellent wireless research programs that Virginia Tech has to offer, Michael decided to resign his position at Lockheed and pursue his masters degree in electrical engineering at Virginia Tech in the fall of 1998. With hard work and perseverance, Michael completed his graduate studies in the spring of 2001. During this time, Michael was also a Graduate Research Assistant at the Center for Wireless Telecommunications where he finished three separate projects ranging from a propagations calculator, systems deployment design for South Boston, Virginia, and systems deployment design for Martinsville, Virginia.