



Interaction

of Low Frequency Sound

with Glass and other Building Materials
in the Design of a Concert Hall for Symphony Orchestra and Choir

by

John Samuel Victor

Thesis submitted to the faculty of Virginia Polytechnic Institute and State University,
in partial fulfillment of the requirements for the degree of Master of Architecture:
Michael Ermann (chair), James Jones, William Galloway

May 5th, 2009, Blacksburg, Virginia, USA

Keywords: Music, Acoustics, Architecture, Architectural Acoustics, Interaction, Sound, Low Frequency, Concert Hall, Symphony, Orchestra, Choir

Copyright © 2009 by John Samuel Victor; All Rights Reserved: No part of this work may be reproduced in part or in full or in a modified format without the written permission of the author



Interaction

of Low Frequency Sound

with Glass and other Building Materials
in the Design of a Concert Hall for Symphony Orchestra and Choir

by

John Samuel Victor

Abstract:

In the world today, Concert Halls for Symphony Orchestra and Choir are generally 'enclosed performance spaces' that are completely cut-off from the outside: Whether it's a time of daylight or moonlight, rain or shine, summer or winter, spring or autumn, the environment within remains the same all the time.

I asked the question:
'What if a concert hall offers views outside?'

To be more specific, the question is:
'What if a concert hall offers views outside through the use of glass, along with other building materials, despite the fact that glass offers lower reflectivity and lower transmission loss for lower frequencies of sound, compared to certain other materials?'

Hence the title:
Interaction of Low Frequency Sound with Glass and other Building Materials
in the Design of a Concert Hall for Symphony Orchestra and Choir.

Without God's Grace it would not have been possible to accomplish this thesis.

To the Lord God Almighty whose Name is Jesus Christ be all the Glory and Honor and Praise!

I thank the Lord especially for my parents Mrs. Pauline Vimala Christabelle and Mr. Victor Thiruthuvathason Sundariah David and my sister Dr. Nina Palmy David

Contents

Prologue	1
The Context	7
The Idea	10
The Design	55
Postlude	77
References	84
Illustrations	85

Prologue

“I had not realized that music could be so beautiful,”

exclaimed Bruno Walter when he conducted for the first time in...



Illustration 1

...Grosser Musikvereinssaal, in Vienna, Austria.¹

This 'realization of the beauty of music' not only depends on:

power of words

(if sung), in poetry like that of John Milton and Fanny Crosby;

richness of compositions

by composers like Johann Sebastian Bach and George Frideric Handel;

fineness of musical instruments

like Stradivarius violins and Steinway and Sons pianos; and

virtuosity of performers and conductor

of the symphony orchestra and choir; but also on

responsiveness of the concert hall

in which the performance takes place.²

Nearly every conductor echoes Bruno Walter when referring to Grosser Musikvereinssaal: "This is the finest hall in the world: It has **depth of sound** and power."³

Leo Beranek, said:

"The 'pulse of any conductor quickens' when [s]he first conducts in this renowned hall."⁴

Conductor Herbert von Karajan added:

"The sound in the hall is full: **It is rich in bass** and good for high strings.

[However], one shortcoming is that successive tones tend to merge into each other.

[Also], there is too much difference in the sound for rehearsing and the sound with audience."⁵

Grosser Musikvereinssaal, Vienna, Austria, opened in 1870,⁶ and eventually became the forerunner of...



Illustration 2

...the Symphony Hall, in Boston, USA, built in 1900.⁷

Though there are a few negative features in Symphony Hall, as there are in every hall, conductors Walter, Karajan, Boudlt, Munsch, Bernstein and Leinsdorf rank it as one of the three best in the world.⁸

They agreed, (when interviewed in 1961), that it is the “most noble of American concert halls.”⁹

“When this hall is fully occupied, the sound is just right-divine.”¹⁰

It is, “An excellent hall: there is none better.”¹¹

Leo Beranek writes:

“The hall responds immediately to an orchestra’s efforts.”¹²

The third concert hall that is considered to be one of the three best in the world is...



Illustration 3

...the Concertgebouw, in Amsterdam, Netherlands, which opened in 1888.¹³

Leo Beranek records the opinions of conductors of major orchestras and soloists:
“I went into the audience and heard the Boston Symphony.”¹⁴

“The reverberation in this hall gives great help to a violinist: As one slides from one note to another, the previous sound perseveres and one has the feeling that each note is surrounded by strength.”¹⁵

Leo Beranek explains: “The sound is well balanced, **strong in bass**. The reverberation sounds greater than that in other rectangular halls, a quality that generally pleases visiting conductors. The cello (in a concerto) sounds loud and luxurious. The full orchestra plays with rich tone. For those who love a **full sumptuous sound with rich bass**, and completely surrounded in an ocean of music, this hall has no superior.”¹⁶

However well they might 'respond' to the music performed, concert halls for symphony orchestra and choir are generally 'enclosed performance spaces' that are completely cut off from the outside: Whether it's a time of daylight or moonlight, rain or shine, summer or winter, spring or autumn, the environment within remains the same all the time.

Though there are a few concert halls where glass has been used to offer views (examples: Casa da Musica, in Porto, Portugal,¹⁷ Harmony Hall, in Kansai, Japan,¹⁸ Esther Eastman Center, in Lakeville, USA),¹⁹ it is these halls that do not use a lot of glass, except at certain places like clerestory windows, Grosser Musikvereinssaal, in Vienna, Symphony Hall, in Boston, and Concertgebouw, in Amsterdam, that are considered the best in the world,²⁰ although they were constructed more than an century ago.

One important reason for avoiding or limiting use of glass in concert halls to offer views, is its inability to reflect low frequency sound: Where does glass stand compared to concrete (for example), with reference to absorption coefficient and transmission loss values, and why is it a problem for low frequencies of sound when used in a concert hall?

At a frequency of 125 Hz, the sound absorption coefficient value of heavy glass is 0.18 whereas for rough concrete it's 0.01.²¹ Since reflectivity is the inverse of absorption, concrete reflects 99% of the 125 Hz sound incident on it whereas glass reflects only 82% of the energy. This has an impact on 'bass ratio' when used extensively in a concert hall. However, both materials reflect 98% of the sound energy at 4000 Hz.²²

At a frequency of 125 Hz, the transmission loss value of double glazing (which has a 3/4" glass + 4" air space + 1/4" glass configuration) is 32 decibels, whereas for 4" thick concrete it's 48 decibels.²³ This allows environmental noise to get into the concert hall, when it should be extremely quiet. However, at 4000 Hz, both have a transmission loss value of 67 decibels.²⁴

The problem therefore is for lower frequencies of sound rather than for the higher frequencies.

Concert halls mentioned in the previous pages, which are the three best in the world, use materials that are capable of reflecting low frequency sound back into the hall. That is why conductors exclaim how such halls are 'rich in bass'!

Hence the question is: Is it still possible to use glass in a concert hall to offer views outside? Analyzing the 'sending ends' of halls, the three best halls in the world, have pipe organs that have been built along the wall behind the stage: these pipe organ assemblies absorb sound energy.²⁵ However, these concert halls still perform well, because the rest of the hall 'compensates' for this loss, or in other words, 'prevents further loss'. Instead of building a wall behind the stage with a pipe organ against it, if both are replaced by glass, the sound which the pipe organ assembly failed to reflect is now simply failed once again by the glass. Hence, it 'is' possible to use glass strategically, provided certain adjustments to the design are made.

If the portion of the hall behind the stage, does not open out, it curtails one of the sensory experiences that could be added to the musical experience. If the concert hall were in a site, located in an area with some historical or natural significance, opening out this portion of the hall would result in greater visual appeal.

Also, music, whether with or without words, whether performed alone or in front of an audience, reflects happenings in the world: When William Wordsworth could not understand what the solitary reaper sang, he wrote:

“Will no one tells me what she sings?--

Perhaps the plaintive numbers flow

For old, unhappy, far-off things,

And battles long ago:

Or is it some more humble lay,

Familiar matter of to-day?

Some natural sorrow, loss, or pain,

That has been, and may be again?”²⁶

Antonio Vivaldi’s set of violin concertos: ‘Four Seasons’, and Franz Joseph Haydn’s oratorio: ‘Creation’, are examples of music composed as a ‘reflection of the world’.

Using glass as a backdrop to the stage seems possible, in order to capture changes in seasons and weather patterns. The idea is to compensate or prevent further loss of low frequency sound energy by using hard reflecting materials in the rest of the hall. However, it does not solve the problem of low transmission loss of glass at the lower frequencies. This can only be handled through design that is appropriate to the context...

The Context

The site chosen to design a concert hall offering views outside, is by the Drillfield, at Virginia Polytechnic Institute and State University's Central Campus at Blacksburg. The site was chosen because of its relationship to the drillfield, in that, it offers spectacular views of the heart of the campus.

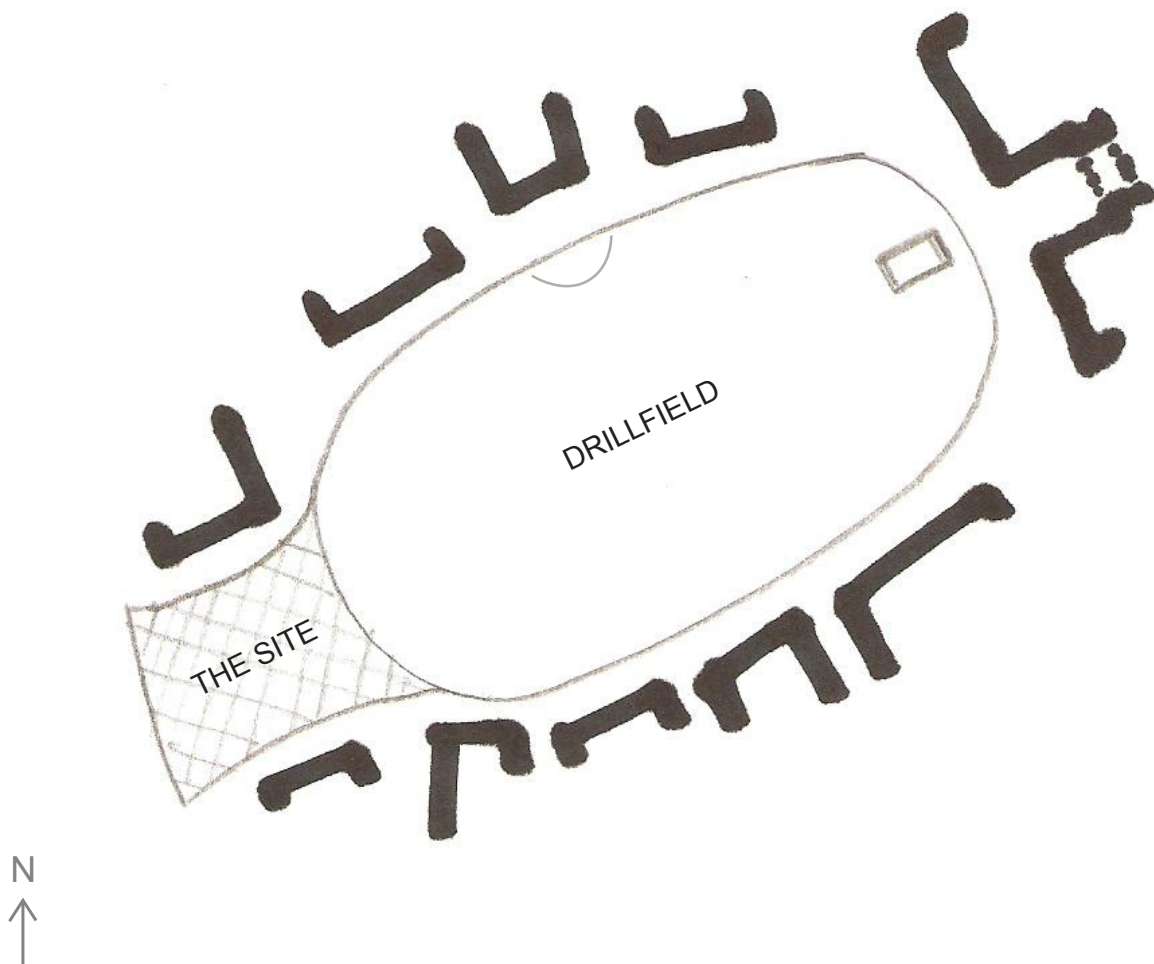

The appearance keeps changing through various seasons of the year when trees change color and shed their leaves, and when snow covers the drillfield.

A facility constructed on this site would terminate the view from Alumni Mall. Also, this is the only site among the various sites around the drillfield, which has four roads adjacent to it.

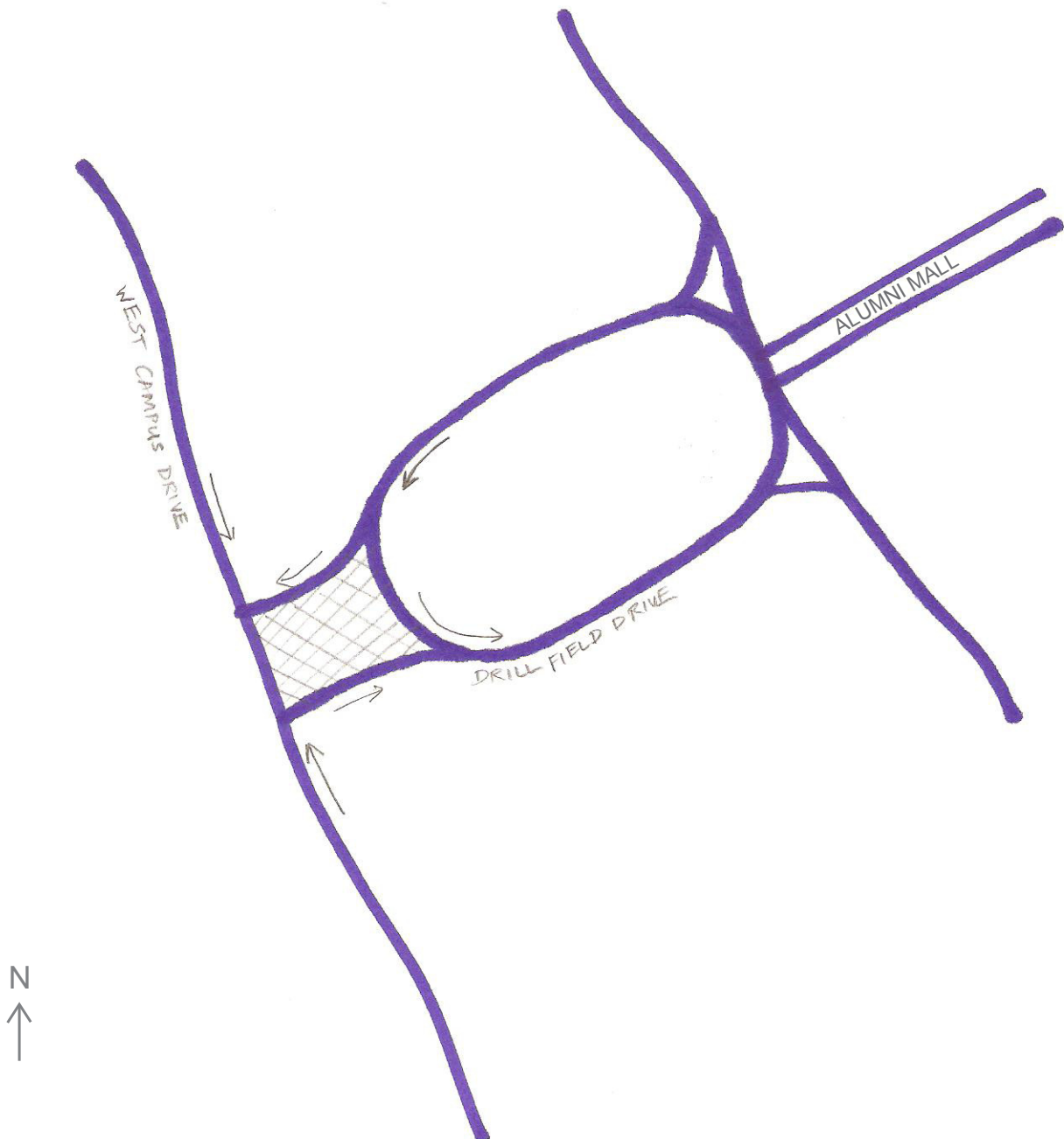

This not only offers additional safety with reference to 'access' in the event of a fire, but also opens up various potentials (that may be considered as challenges) like separate entries into the facility for musicians, public and services, in response to the context.

The drillfield is defined by the facilities built around it. The site under consideration is the only remaining portion around the drillfield.

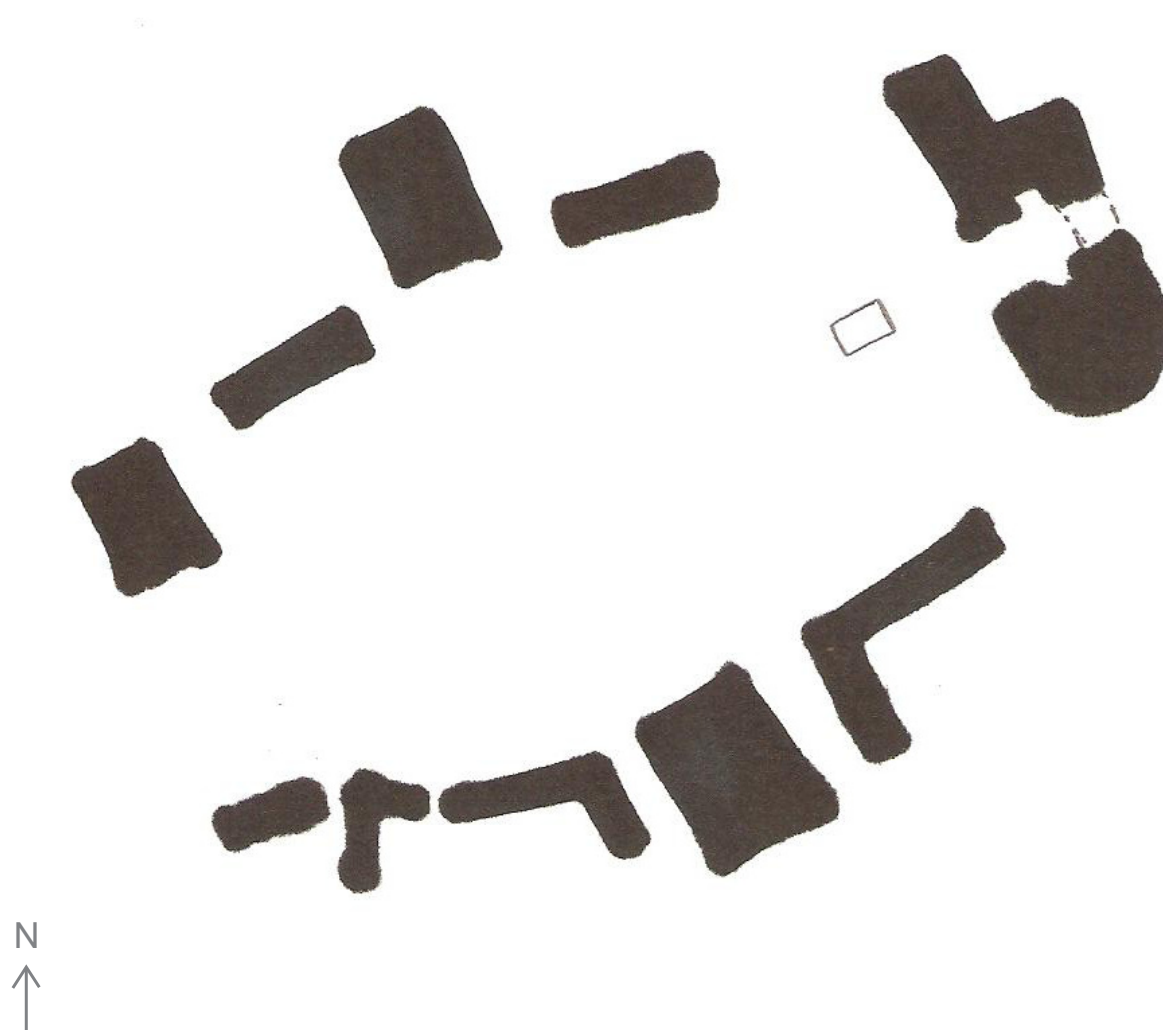

A concert hall, constructed on this site would complete the 'definition' of the drillfield while offering views.

The Idea

The idea for the design of the concert hall is to use Hokie stone for three walls of the hall, and glass as 'backdrop' to the stage, with the concert space flowing into the drillfield, as shown below:

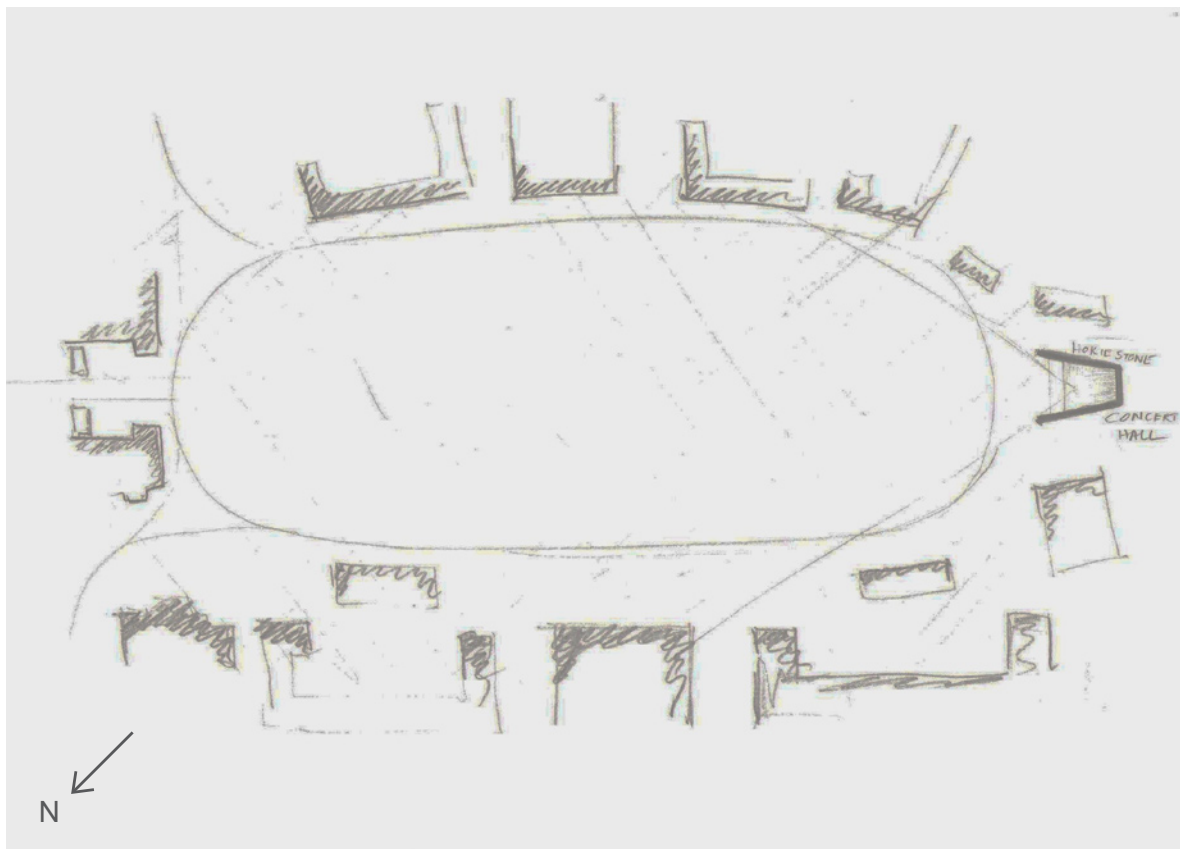

PLAN

(Note: the orientation is different here)

The Hokie stone walls serve to reflect the low frequency sound incident on it, the acoustical details of which are explained later through the thesis, from page 19 onwards.

Hokie stone and concrete are the materials chosen for this design for two reasons: The first is their ability to reflect low frequency sound and the second is that these are the primary building materials used in the facilities around the drillfield.

Concrete is used for ceiling and floor slabs: the top and bottom edges of the frame that defines the view of the drillfield from the hall.

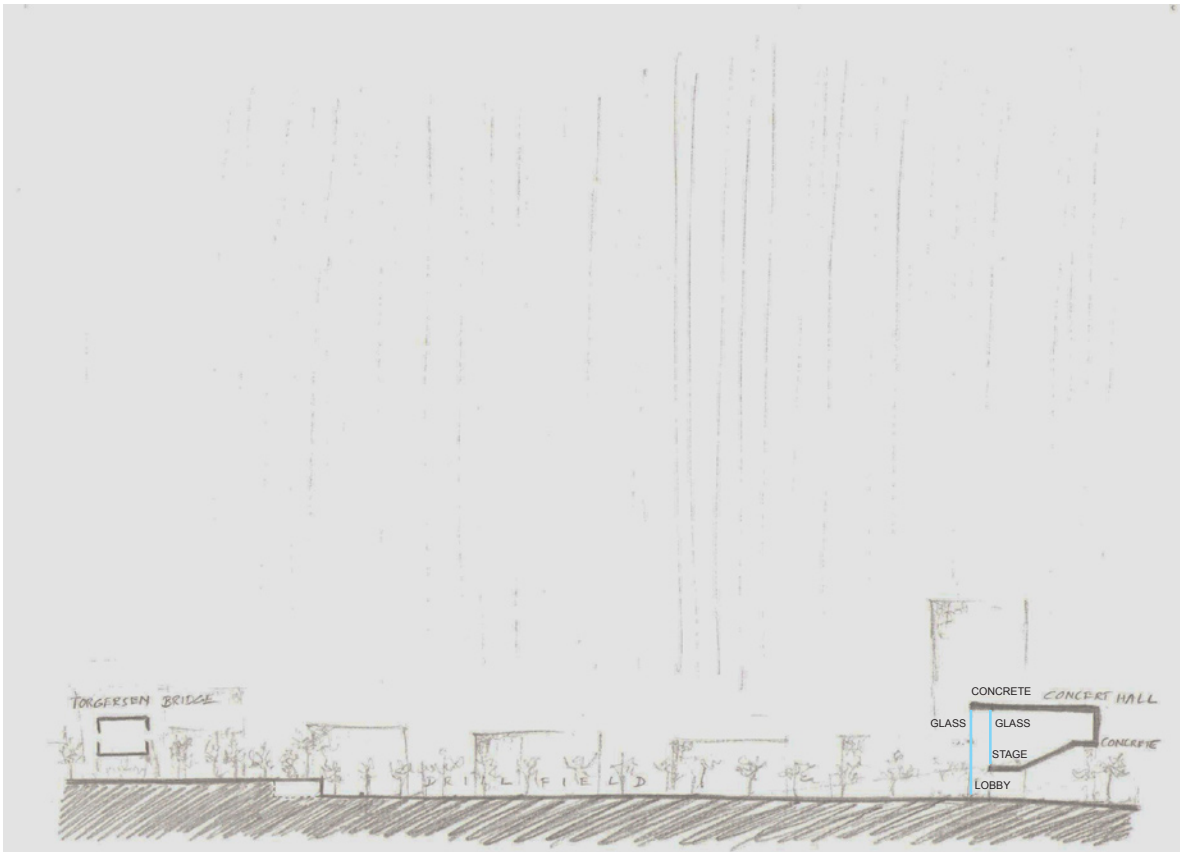

SECTION

The lobby is adjacent to the drillfield, at the ground or entry level, while the stage, which is adjacent to the lobby is lifted-off the ground as shown above.

The design of the ceiling slab is integrated with building systems. The manner in which the ceiling, along with its integrated building systems helps to enhance the acoustics of the hall is explained in detail later through the thesis, from page 35 onwards.

The acoustical reason for having the lobby space between the concert hall and the drillfield with the use of two separate assemblies of glass as in the section above is explained in page 13.

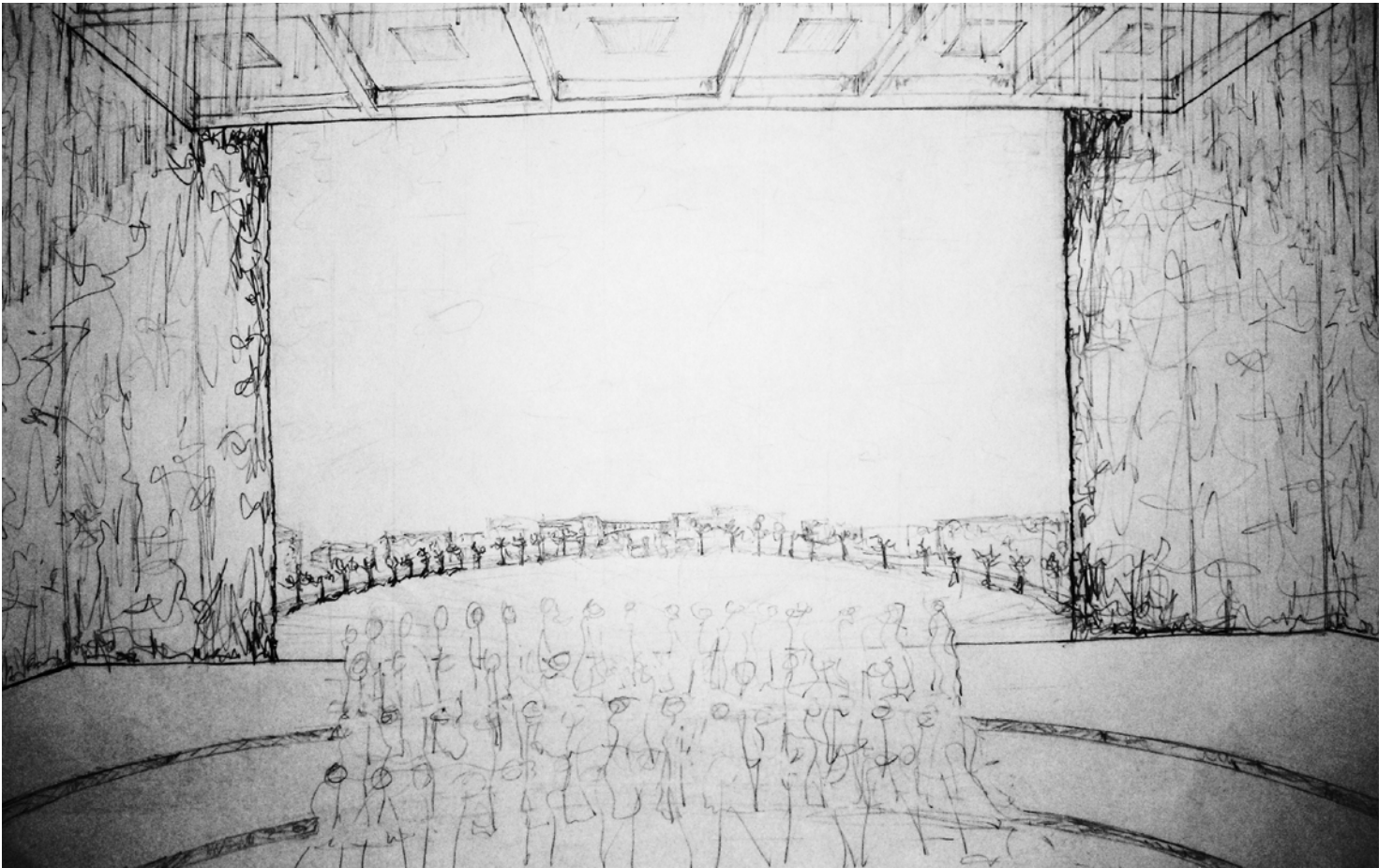

THE IDEA: DRILLFIELD AS BACKDROP FOR THE STAGE

Handling Transmission Loss of Glass in Design

For various configurations and types of glass, the transmission loss at 125 Hz is generally lesser than 33 decibels: For example, the transmission loss of 1" thick insulated glass with 1/8" glass + 3/4" air space + 1/8" glass configuration at 125 Hz is 27 decibels;²⁷ the transmission loss of 3/4" thick three-layered laminated glass at 125 Hz is 33 decibels.²⁸

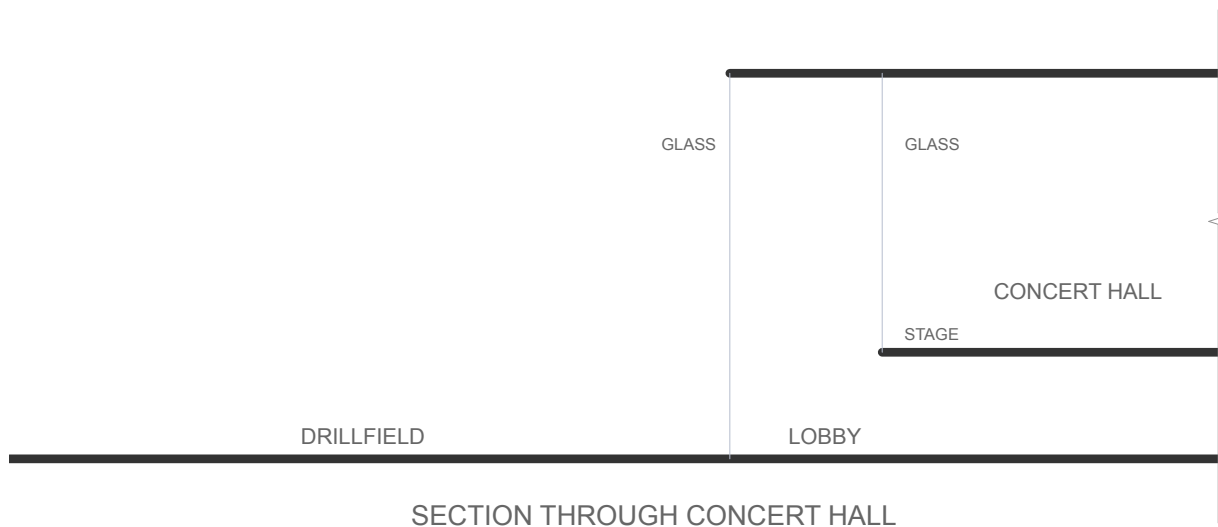

Therefore, the design of the concert hall is handled such that, the lobby space is between the concert hall and the drillfield, with the first assembly of clear glass separating the drillfield from the lobby and a second assembly separating the lobby from the concert hall. This ensures double transmission loss of sound through the two separate assemblies of glass. This configuration of spaces with two assemblies of glass ensures a quiet indoor space for concerts, along with visual connections to the outside. This design also responds to the fact that a lobby adjacent to the drillfield is necessary, since it's the 'most important' space on campus. The glass chosen in this design is 1" thick insulated glass (laminated).

Handling Reflectivity of Glass in Design

Since glass is used as backdrop for the stage when it does not reflect approximately all of the low frequency sound incident on it, the design of the side walls become critical in order to not only prevent further loss of sound energy in addition to what is lost through the glass, but also in distribution of sound energy within the concert hall. Hence, in this design the angle of tilt of the side walls is all the more important in distributing sound energy within the concert hall than in a design where there is no use of glass behind the stage.

The next few pages are acoustic simulations of lateral fraction (LF) of three models of halls with different angles of tilt of the side walls using the program CATT-Acoustic (Computer Aided Theater Technique).²⁹ In all three models, the stage is by the left edge and the audience plane is to the right side of the model.

The three cases of halls analyzed have specific names based on the angle of tilt of the side walls. They are:

1. Fan

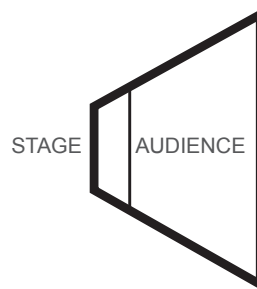

2. Reverse Fan

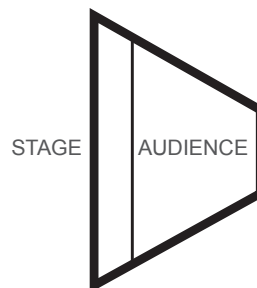

3. Shoe Box

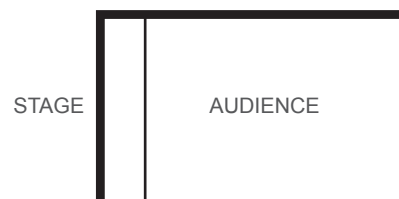

Lateral Fraction Percentage at 125 Hz

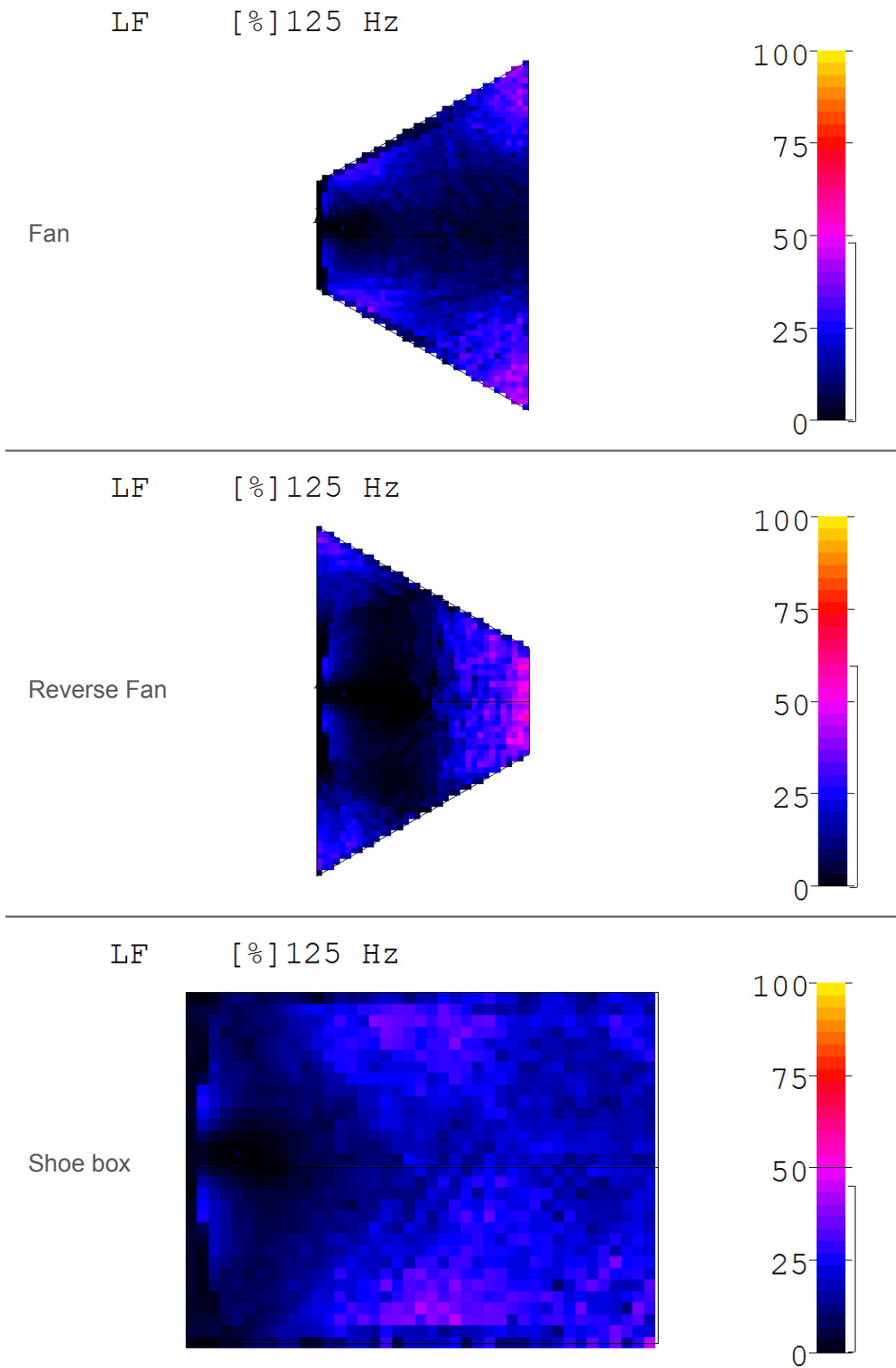

Lateral Fraction Percentage at 500 Hz

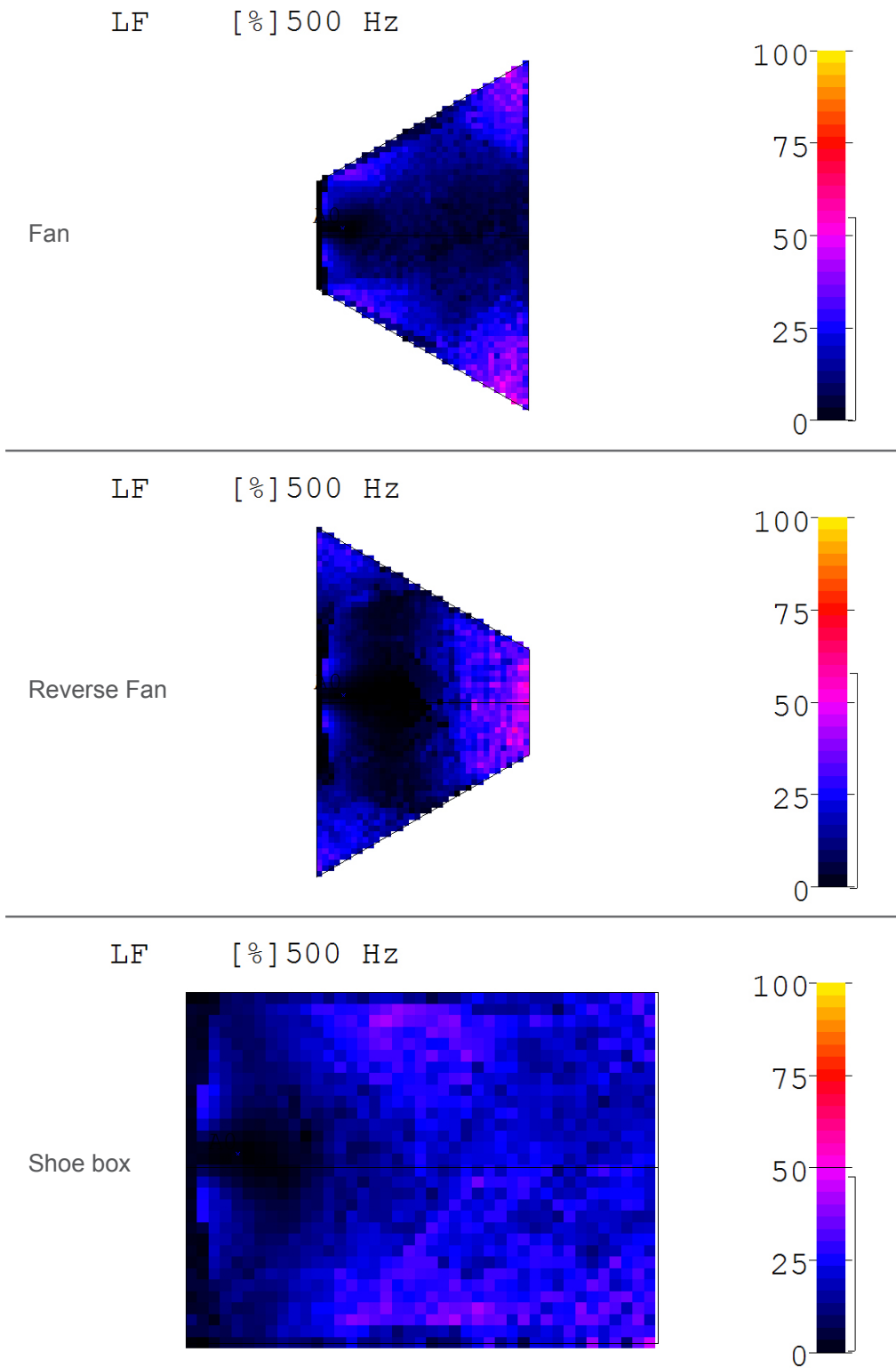

Lateral Fraction Percentage at 4000 Hz

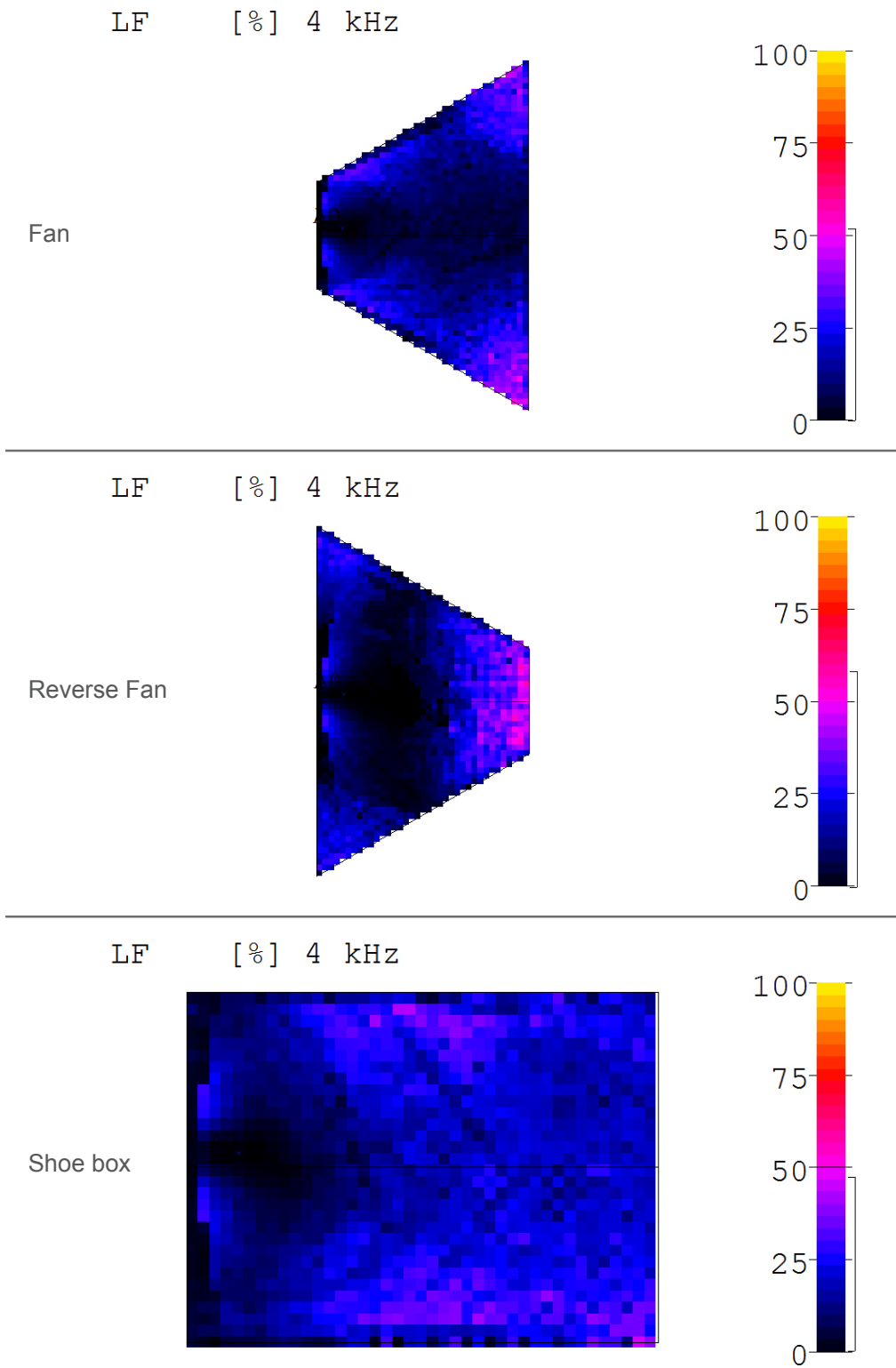

The simulation reveals that the side walls in a shoe box type of hall distribute sound energy more evenly to the entire hall than the fan and reverse fan shaped halls. Not only is lateral fraction important but also the time difference between the direct sound from the source and the reflected sound from the side walls as it reaches a listener under consideration. The lesser this time difference, the better.

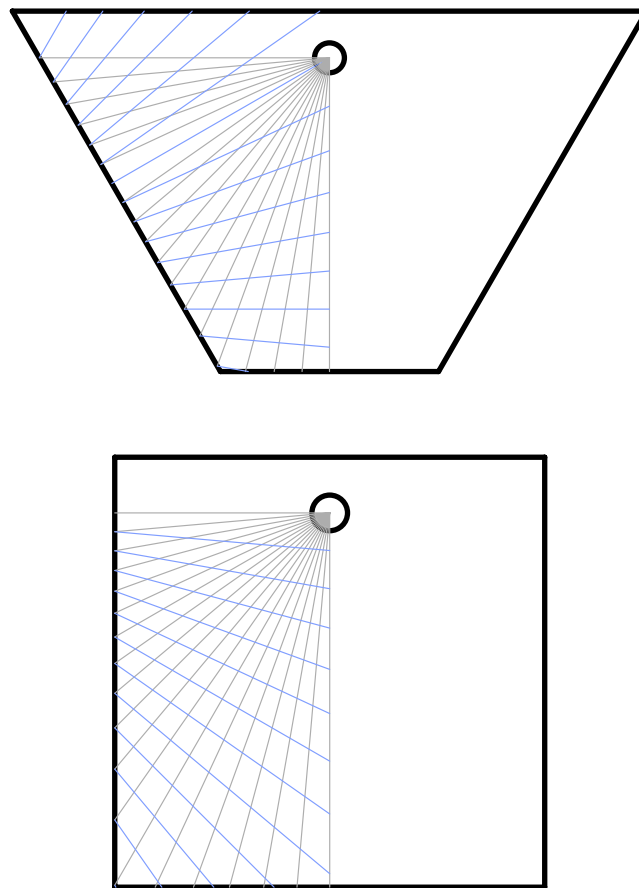

Ray Diagrams of a reverse fan and shoe box type of hall reveal that this difference in time is greater for a reverse fan shaped hall compared to a shoe box type of hall, especially for seats closer to the source (or stage).

Though the shoe box hall has advantages, there is possibility of flutter echo due to parallel walls. Hence, in this design a tilt of 98.5 degrees has been adopted instead of 90 degrees, between the rear wall and the side walls. This also results in better views of the drillfield compared to the strict rectangular plan of the shoe box hall. (The angle between the rear wall and the side walls adopted for the acoustic simulation of the reverse fan shaped hall for analyzing lateral fraction is 120 degrees.)

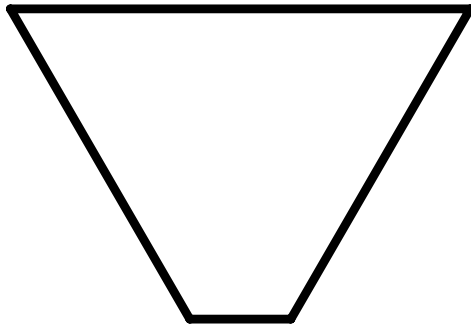

120 degrees

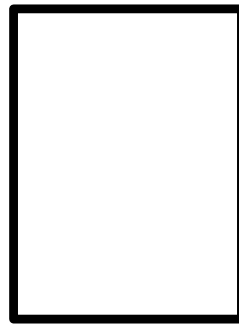

90 degrees

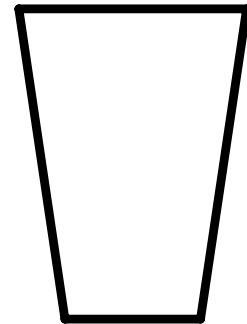

98.5 degrees

The acoustics of the concert hall is not only influenced by the geometry but also by the materials used for the walls and the ability of the material to diffuse sound.

The next few pages are acoustic simulations for three materials (for the walls):

1. 6" Fiberglass (as facing)
2. Concrete
3. Hokie Stone

Clarity Index in decibels at 125 Hz

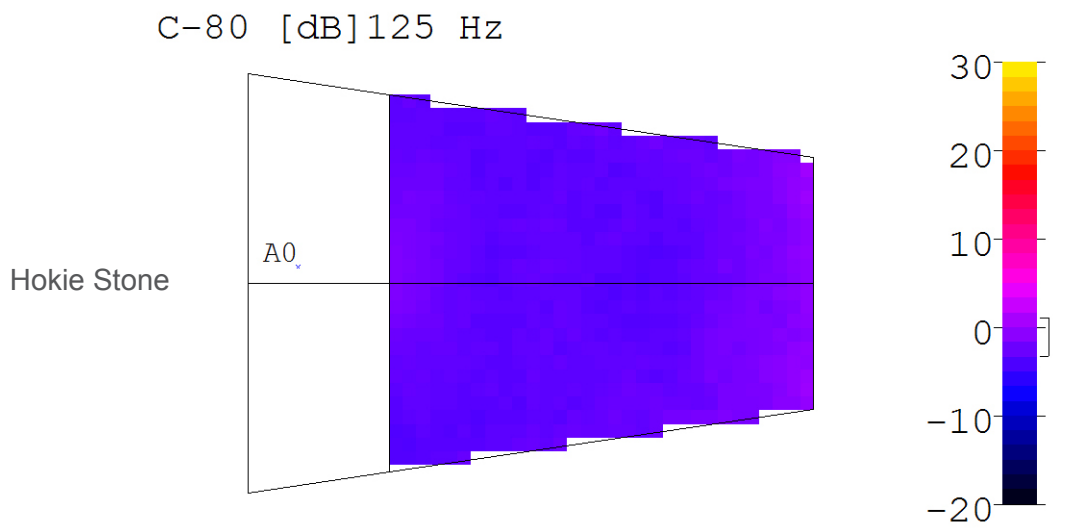
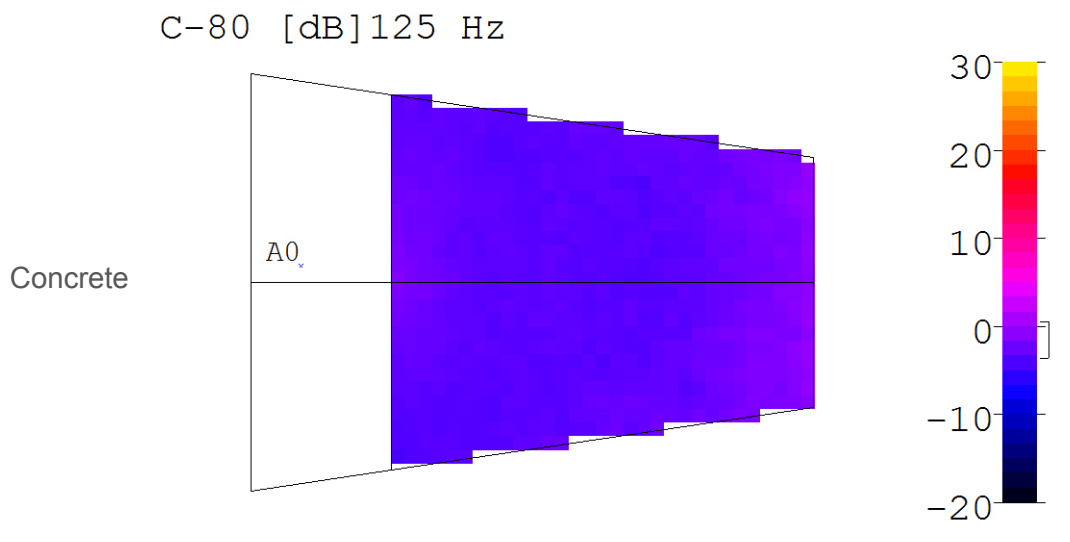
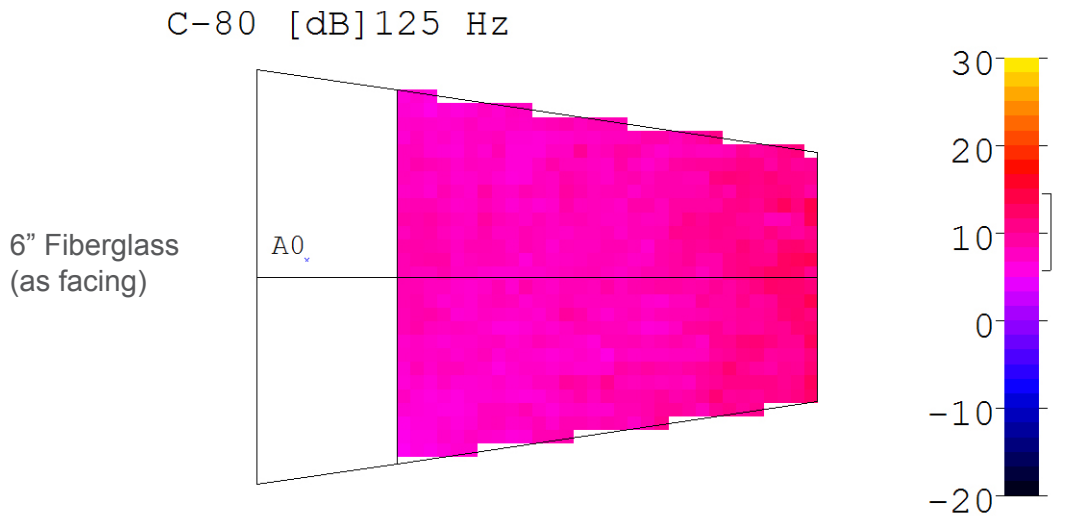

Reverberation Time in seconds at 125 Hz

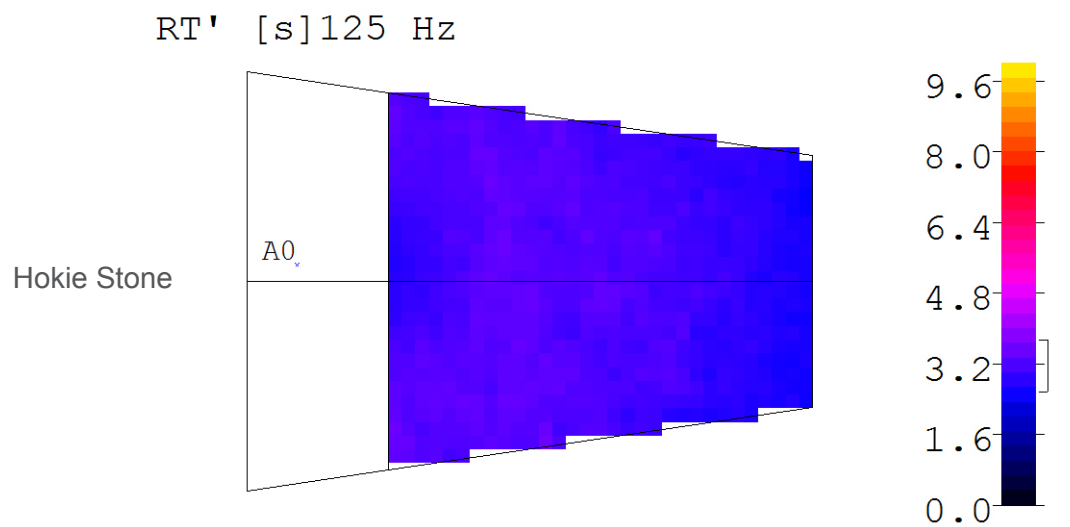
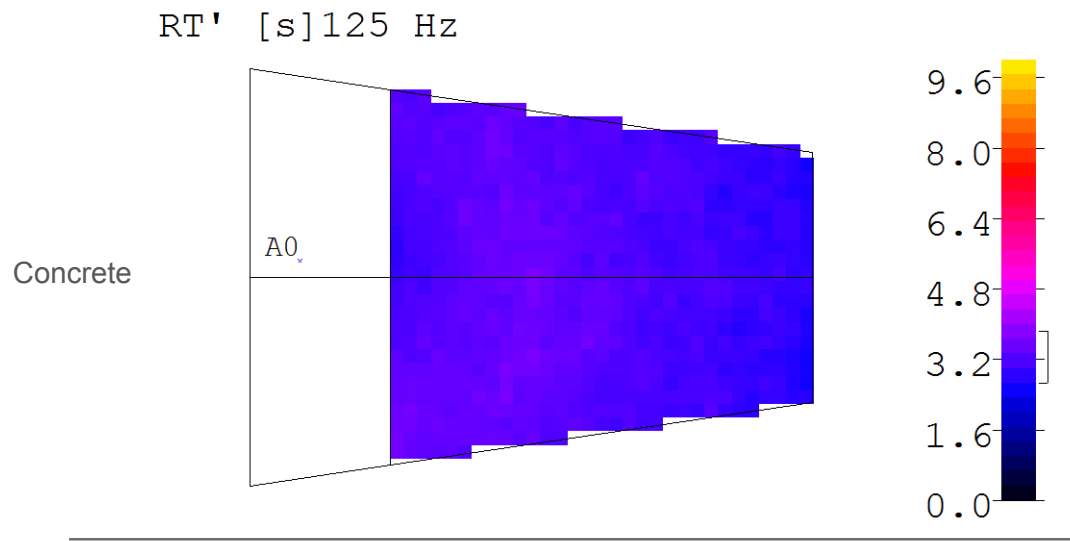
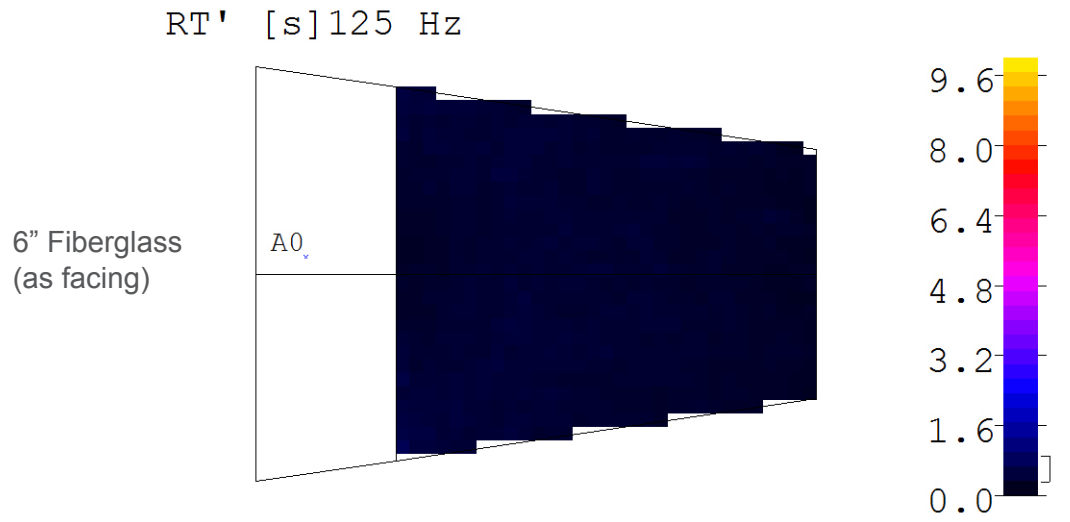

Relative Strength in decibels at 125 Hz

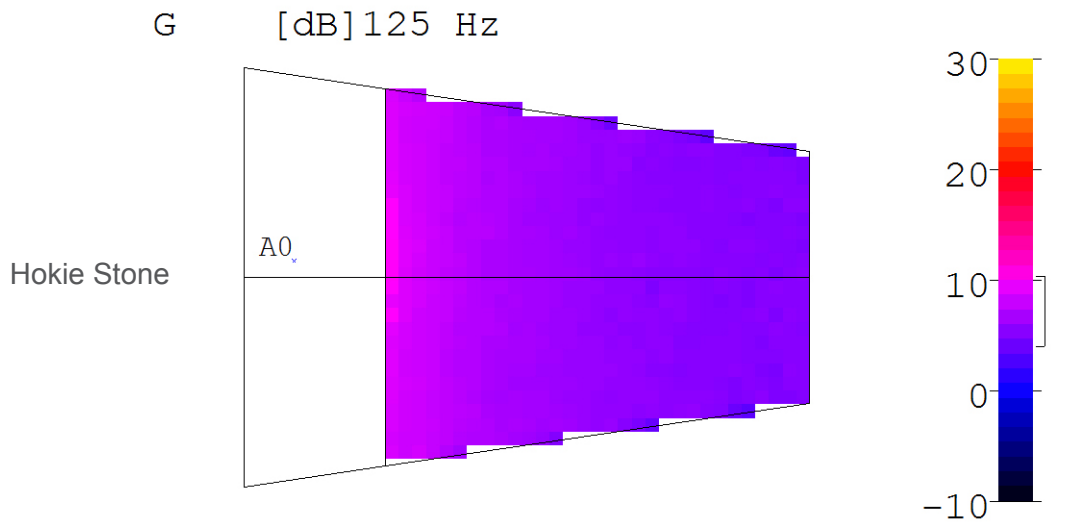
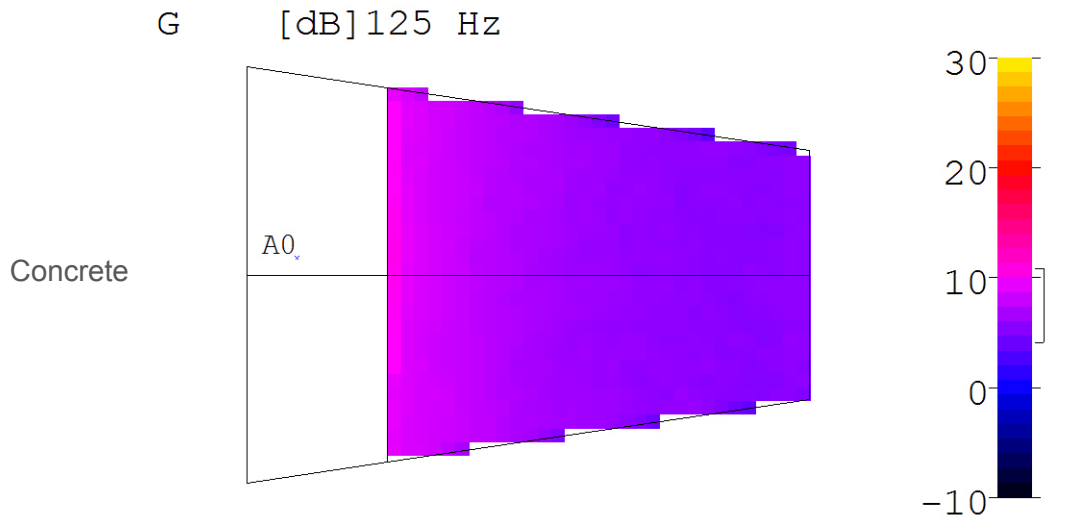
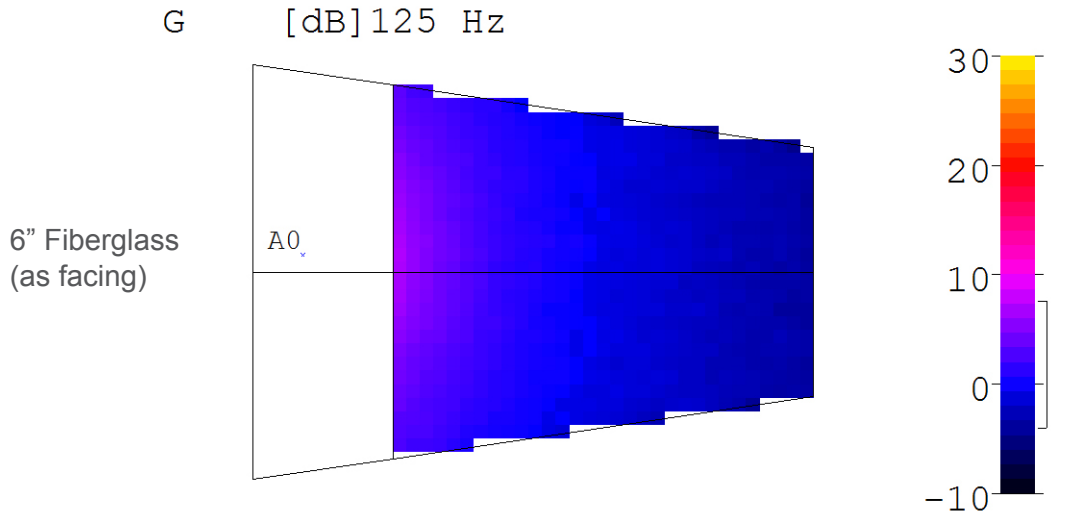

Sound Pressure Level in decibels at 125 Hz

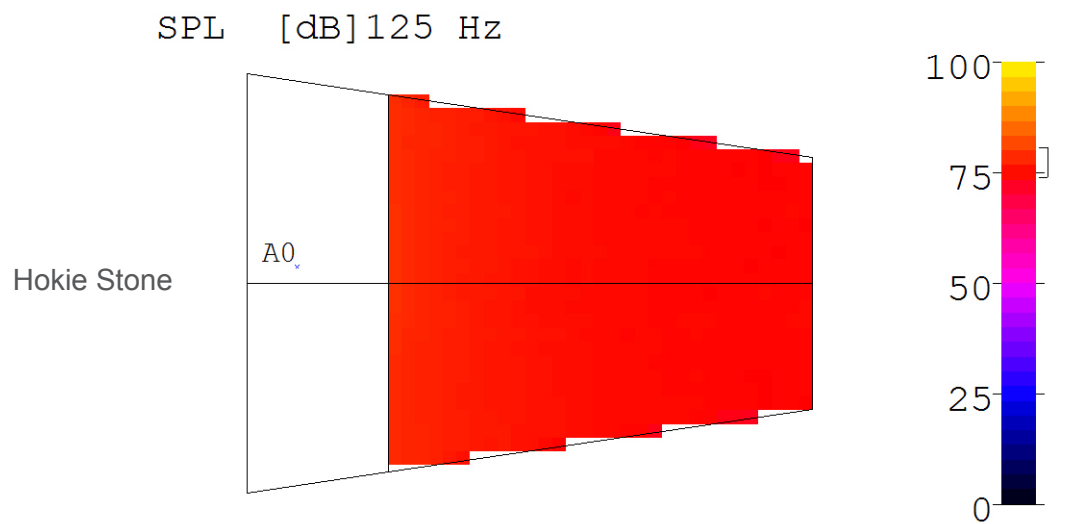
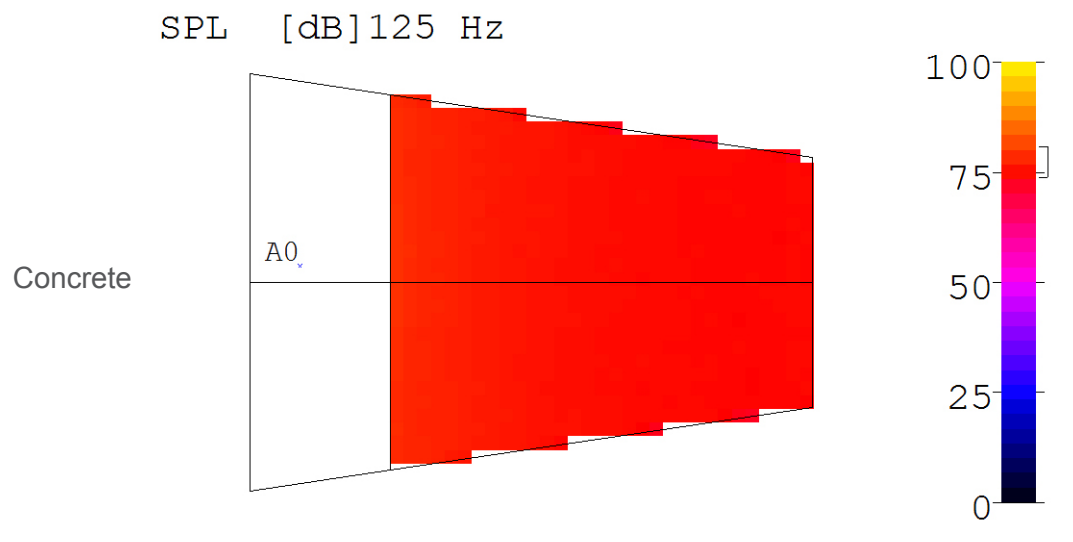
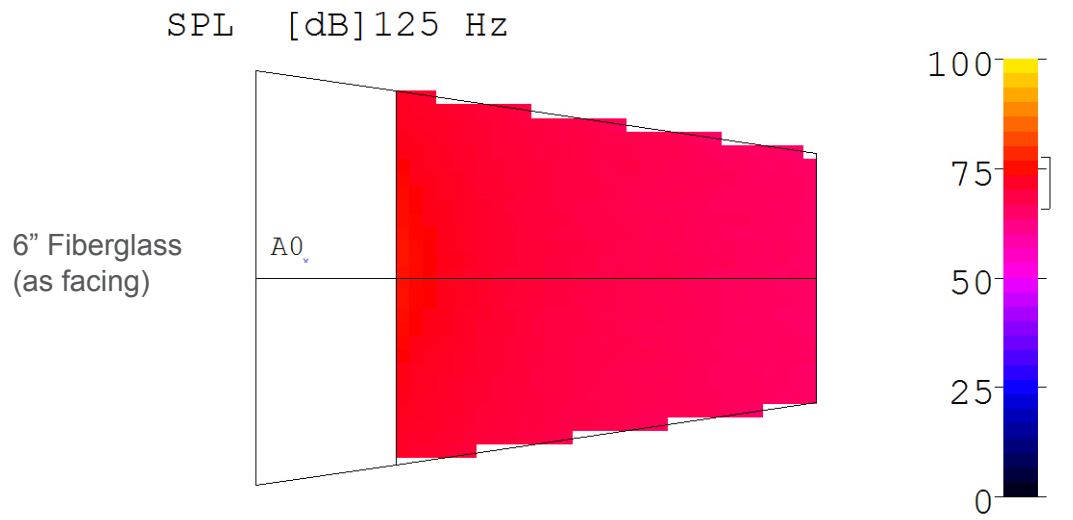

Lateral Fraction Percentage at 125 Hz

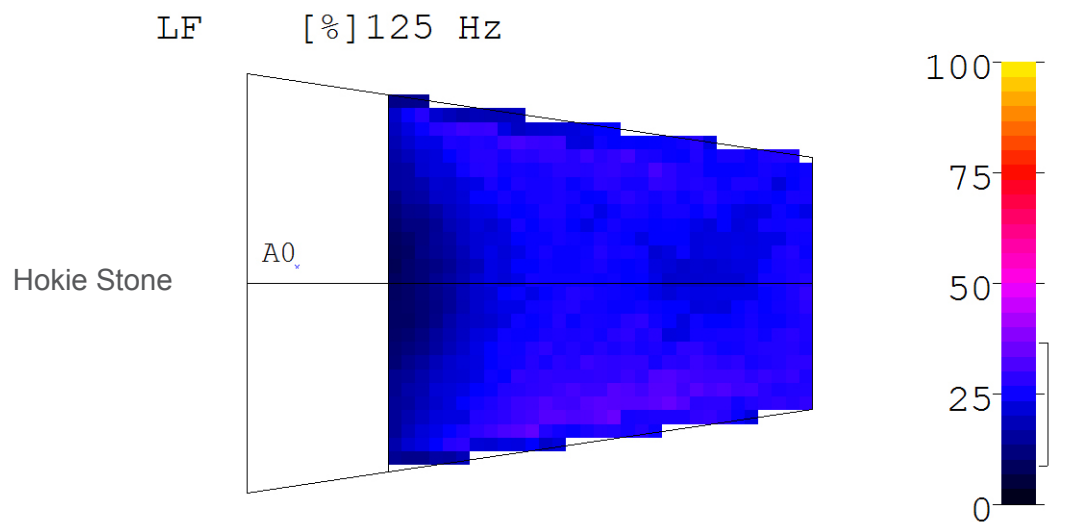
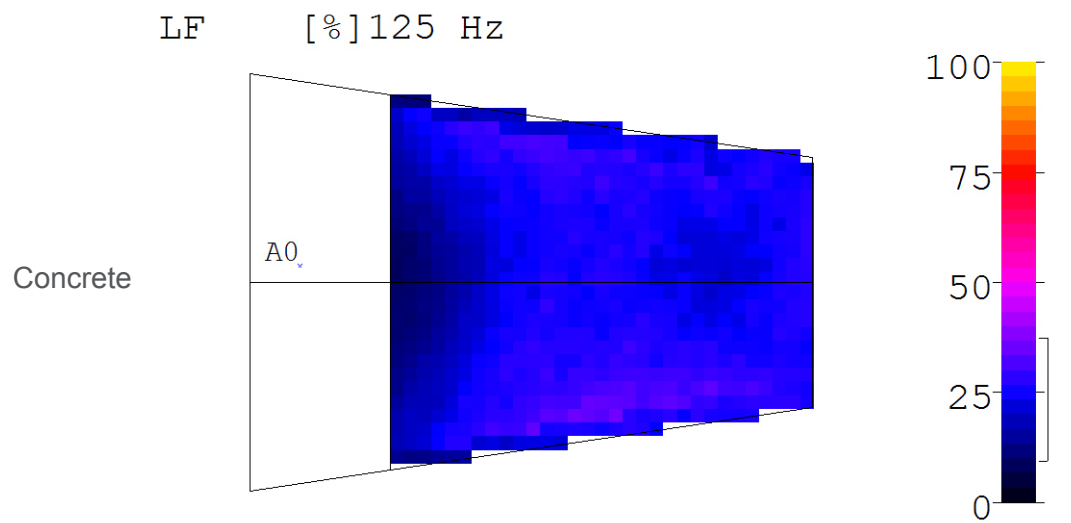
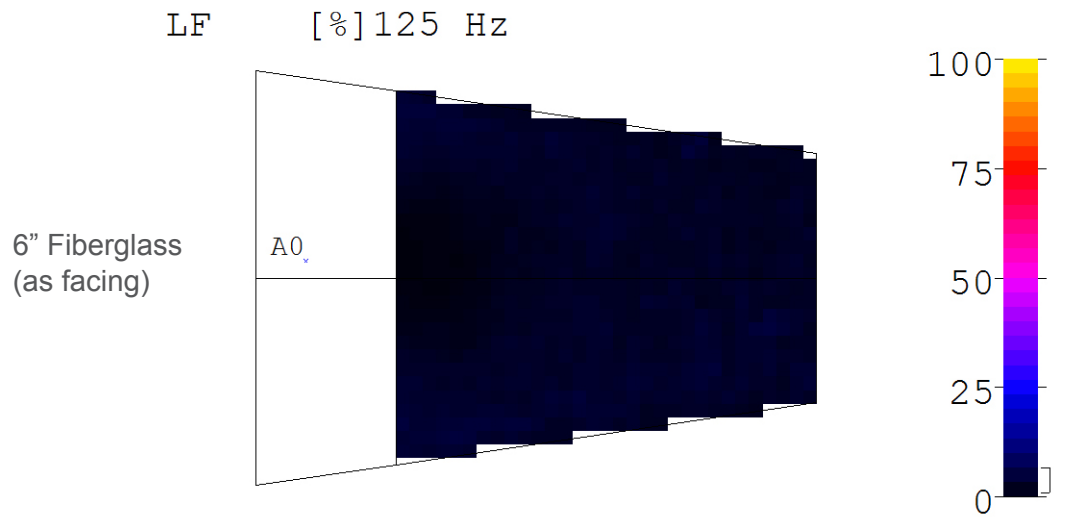

Clarity Index in decibels at 500 Hz

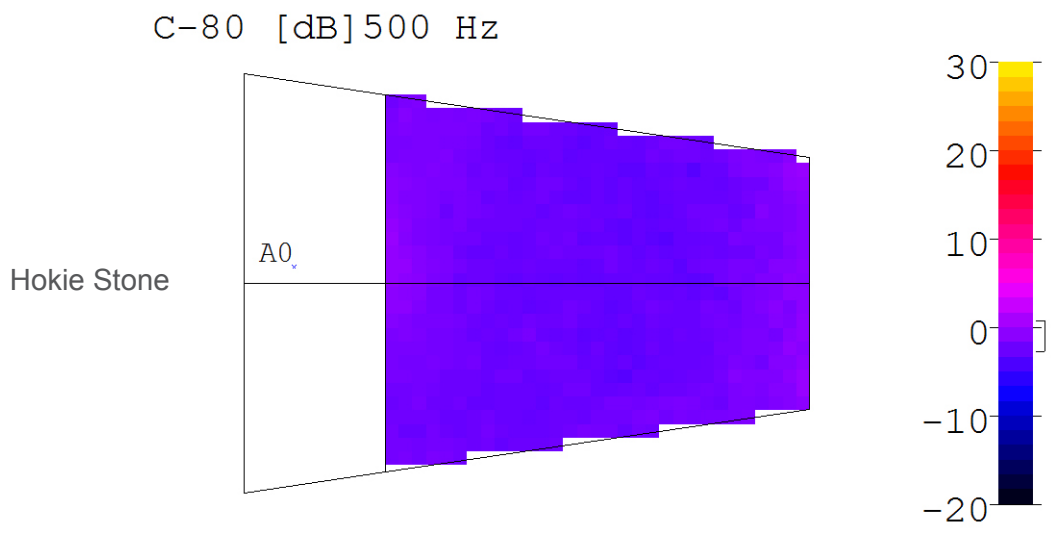
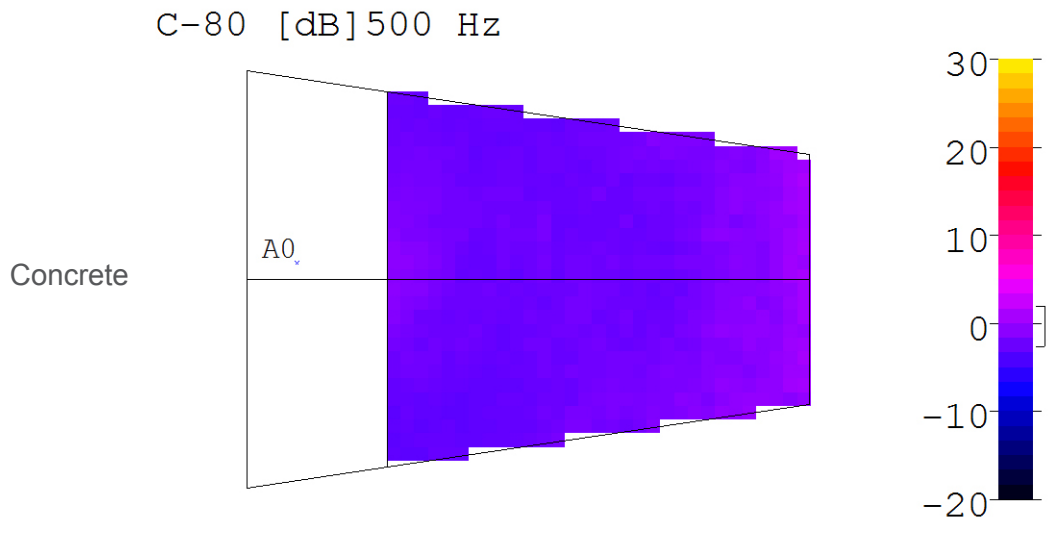
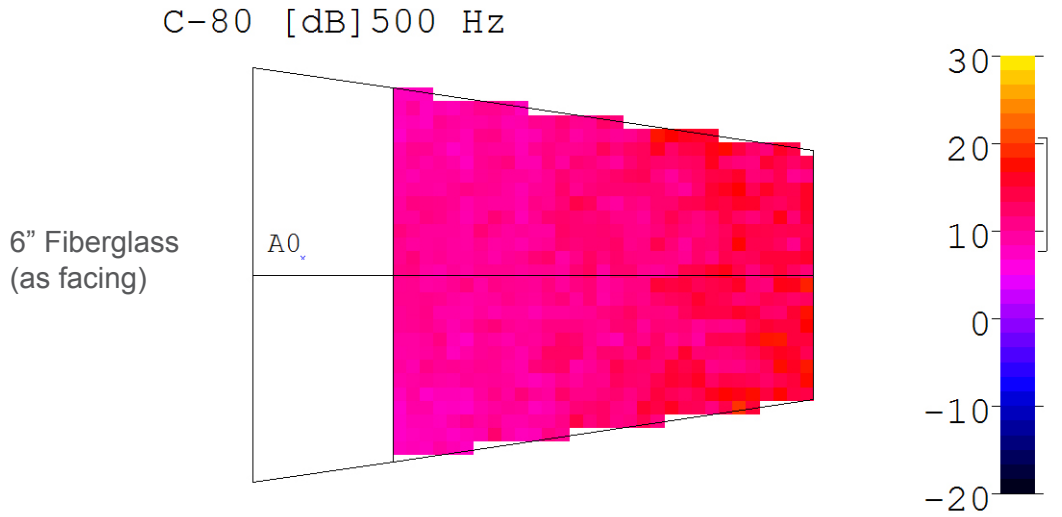

Reverberation Time in seconds at 500 Hz

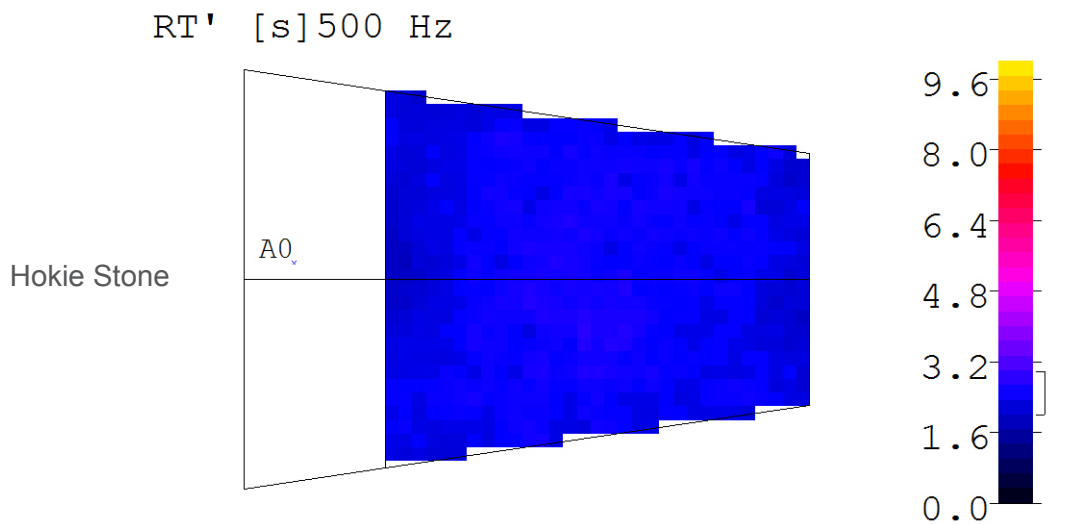
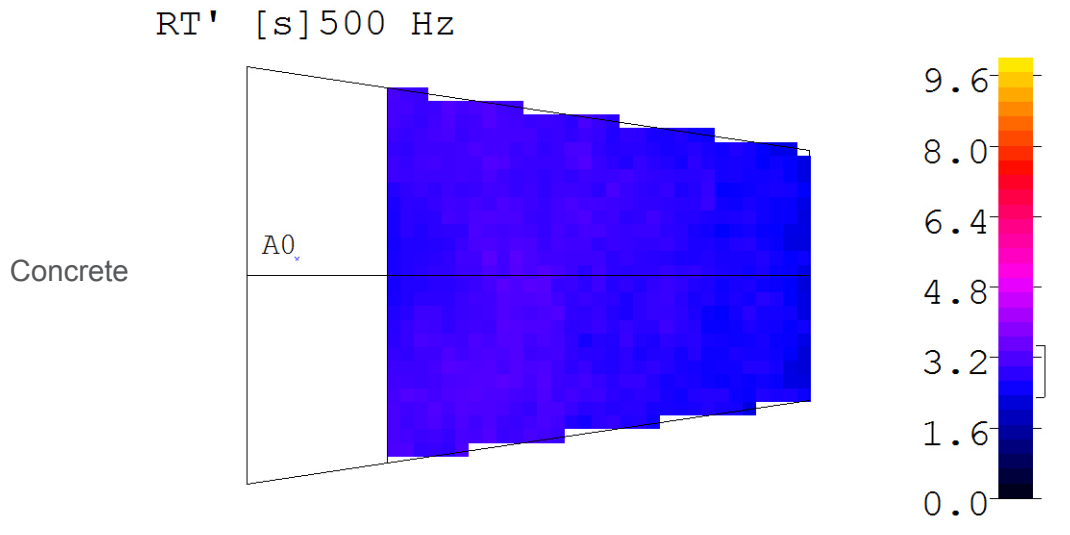
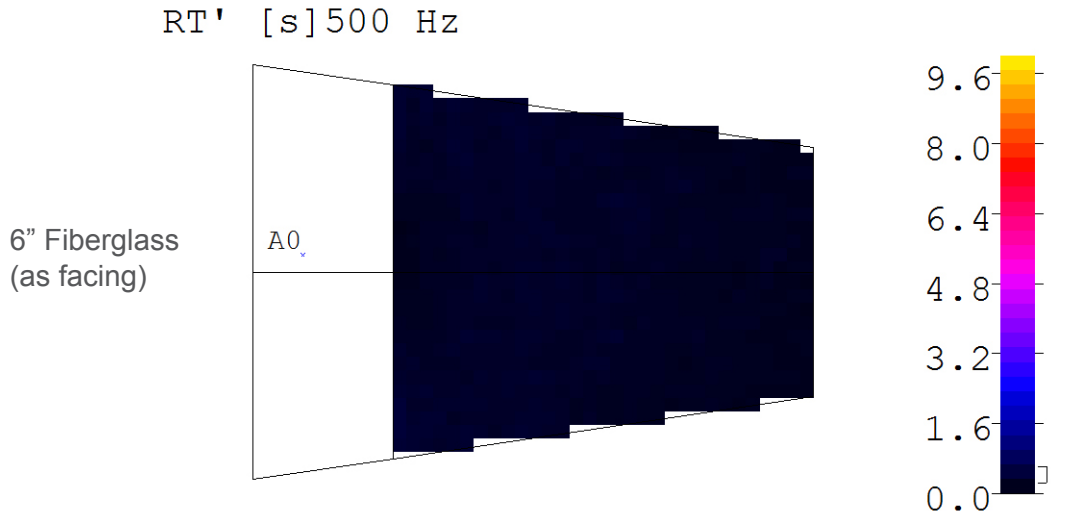

Relative Strength in decibels at 500 Hz

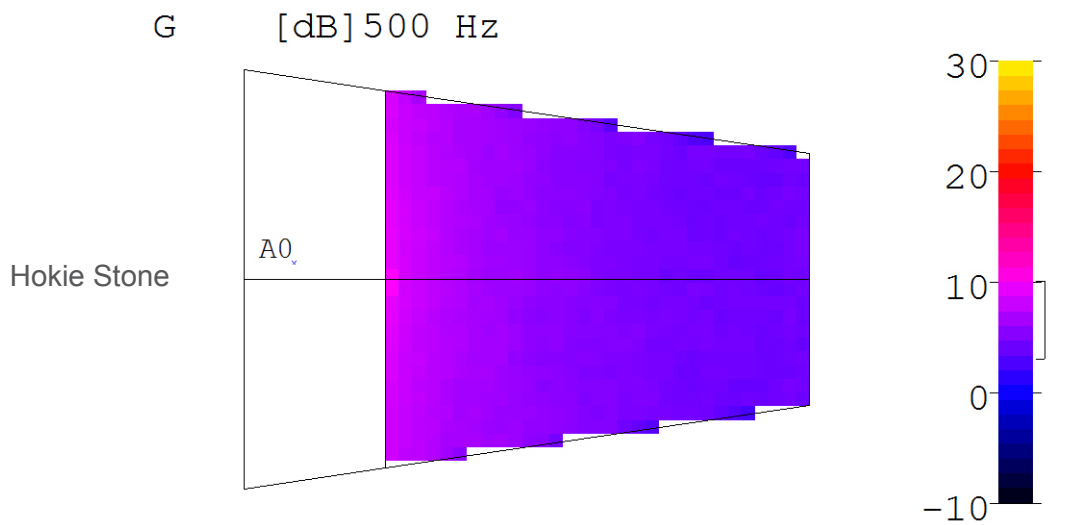
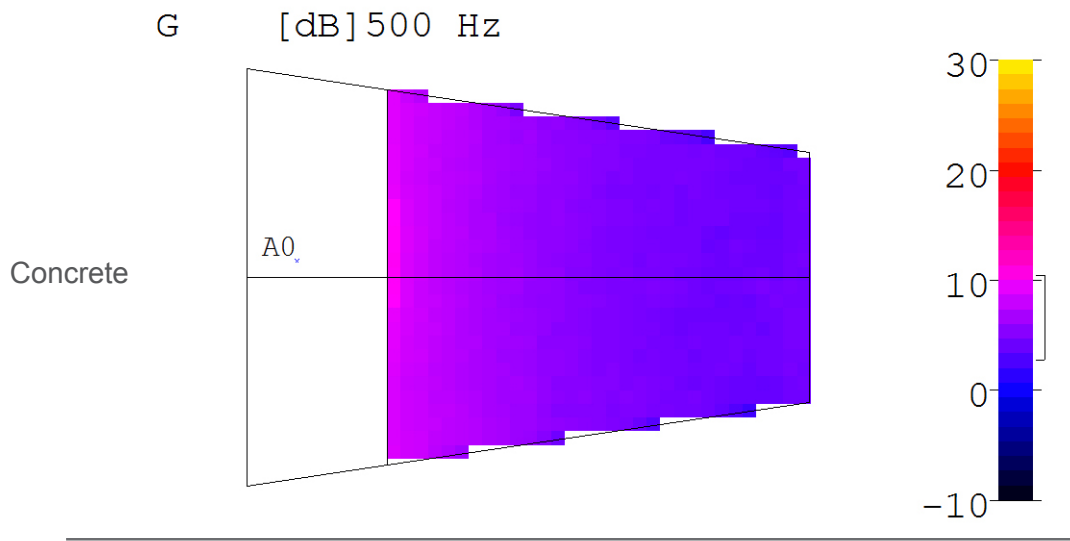
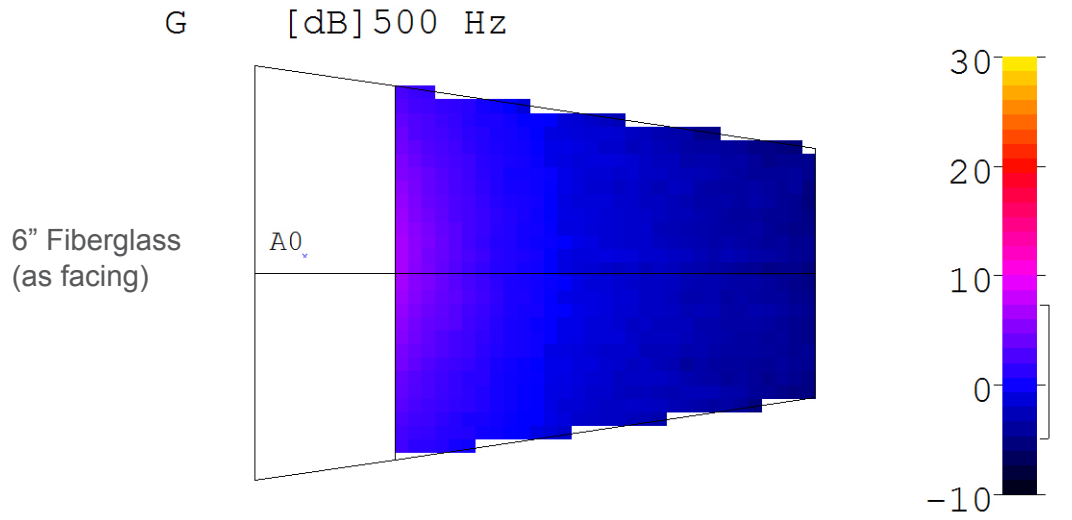

Sound Pressure Level in decibels at 500 Hz

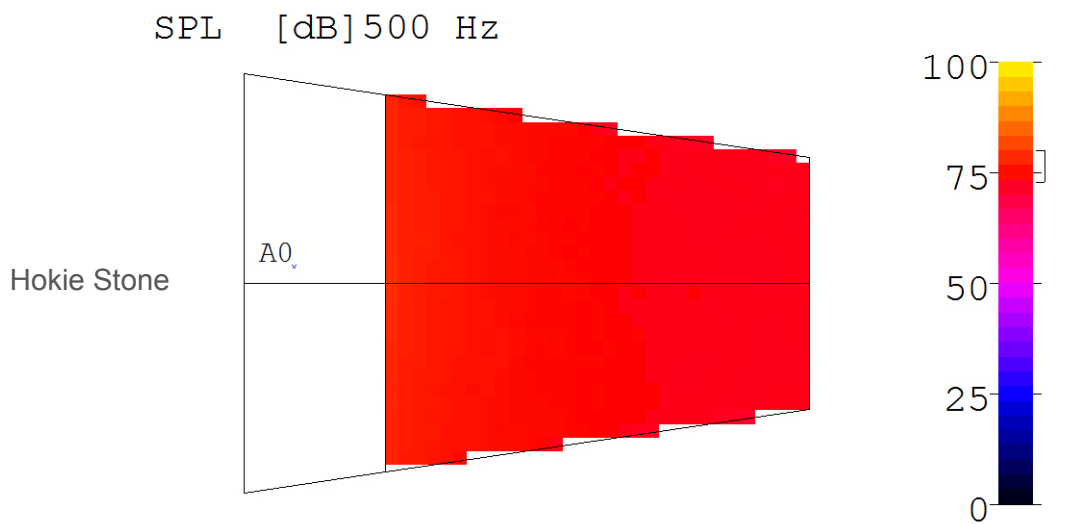
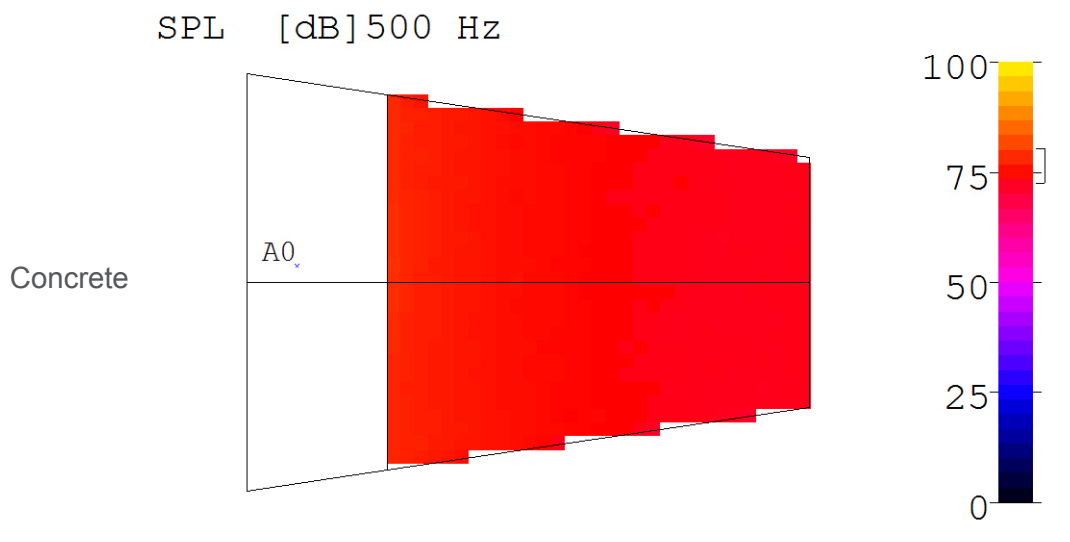
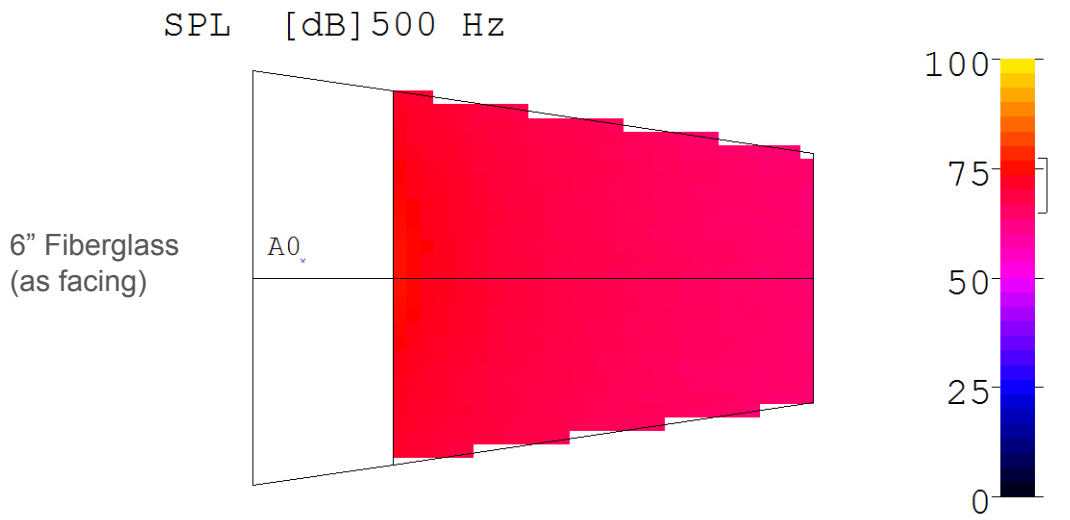

Lateral Fraction Percentage at 500 Hz

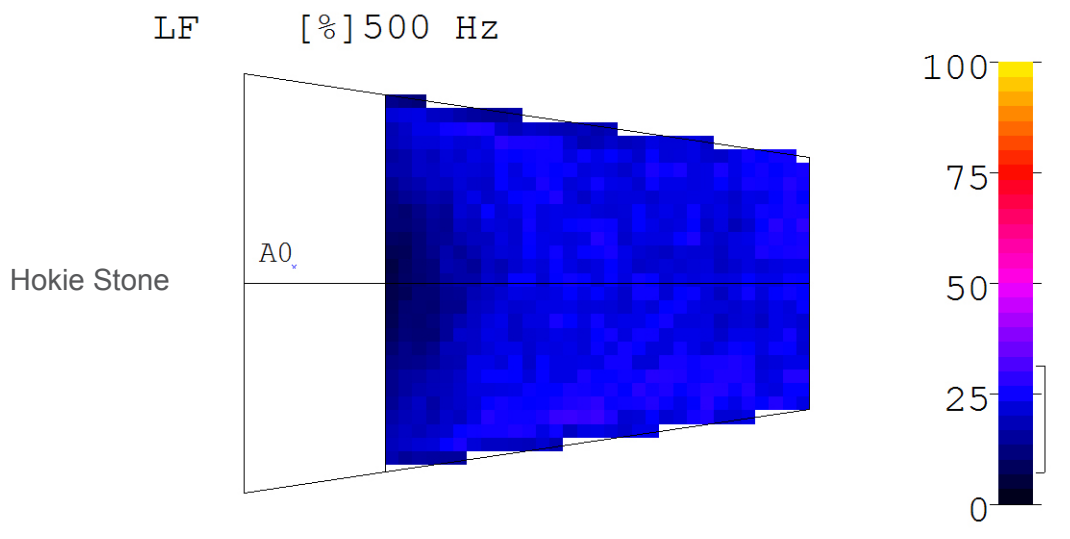
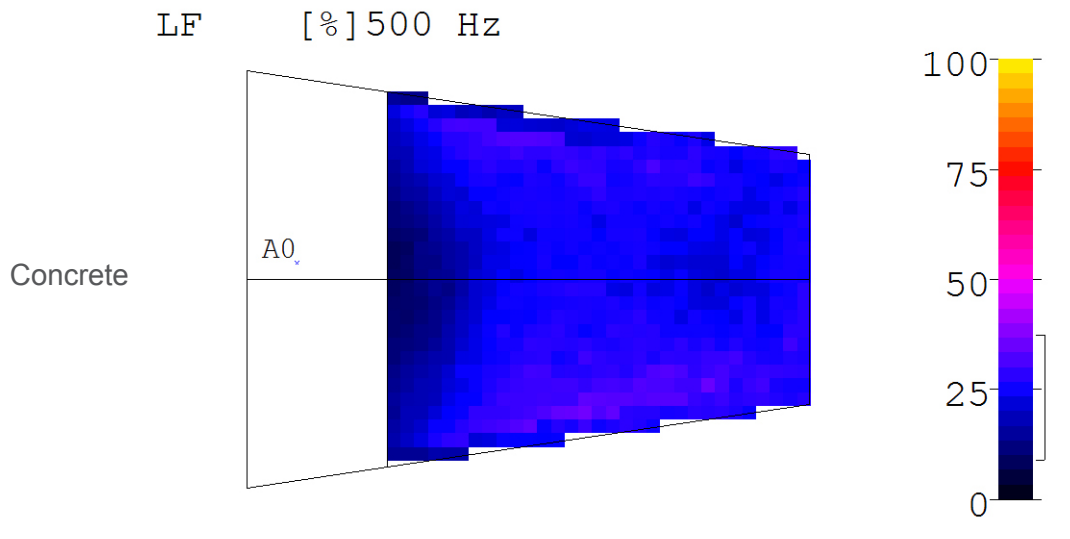
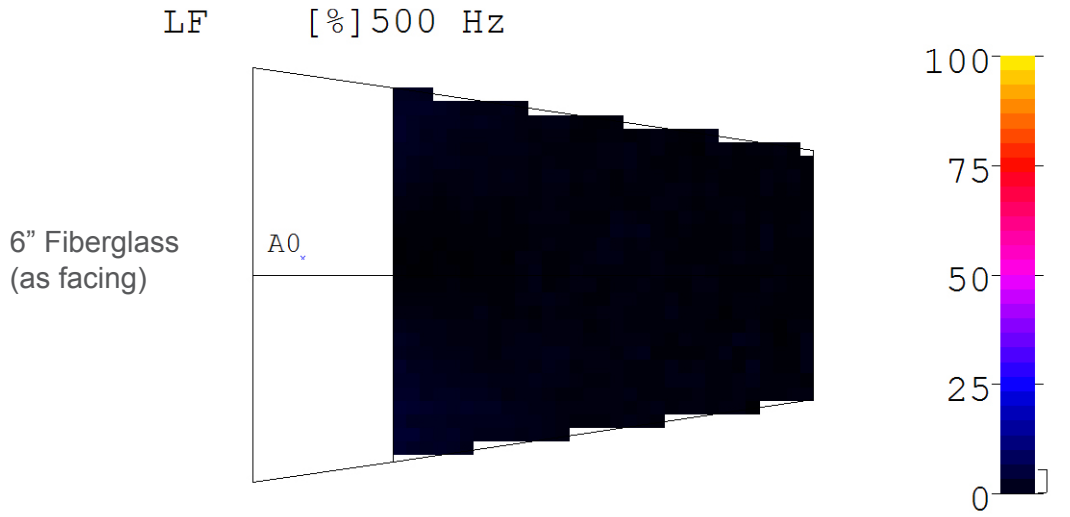

Clarity Index in decibels at 4000 Hz

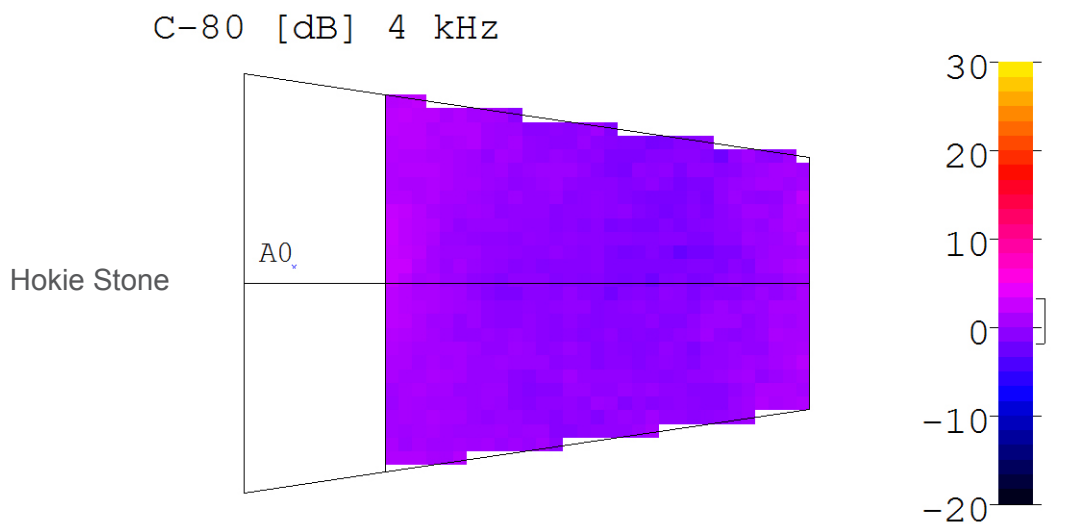
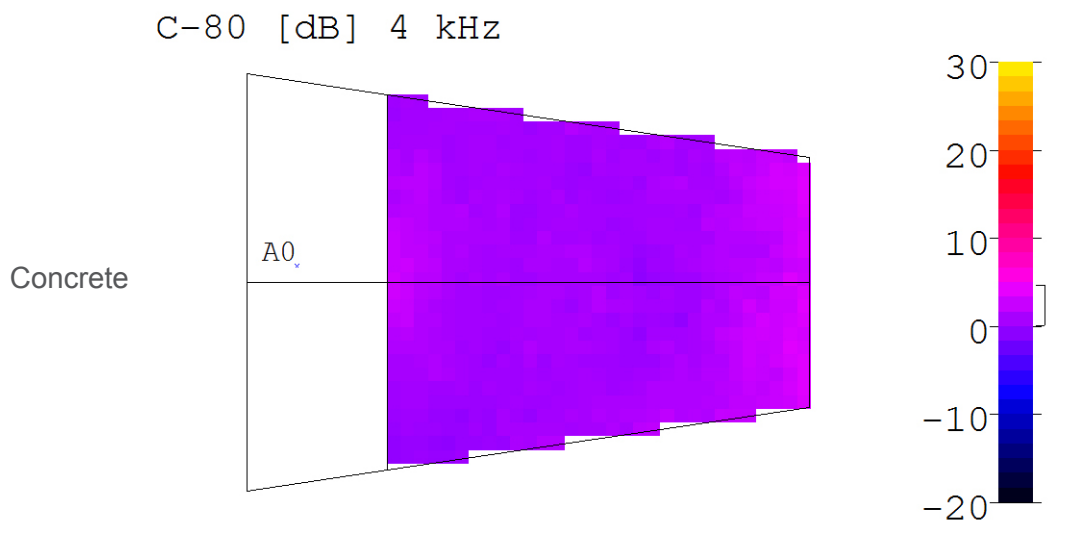
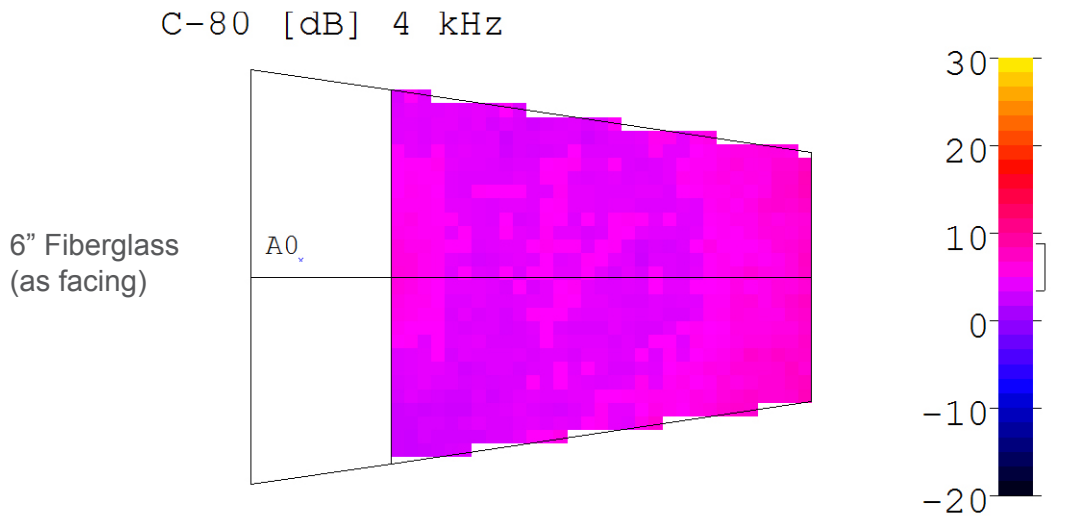

Reverberation Time in seconds at 4000 Hz

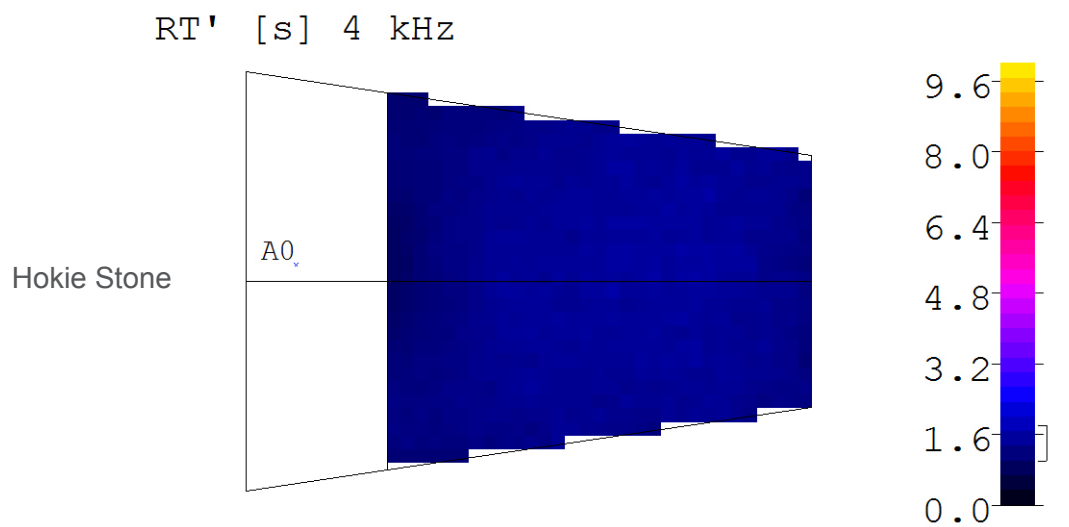
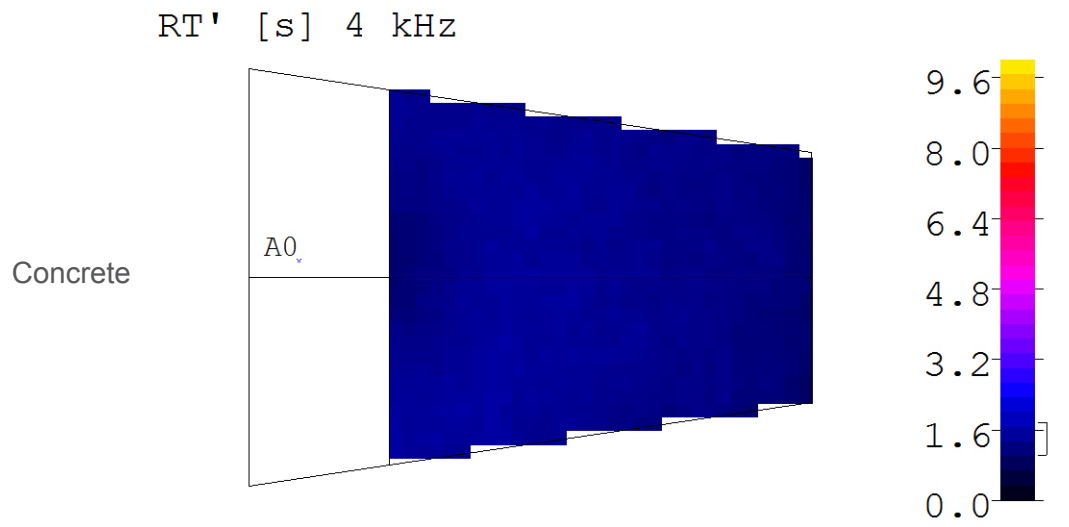
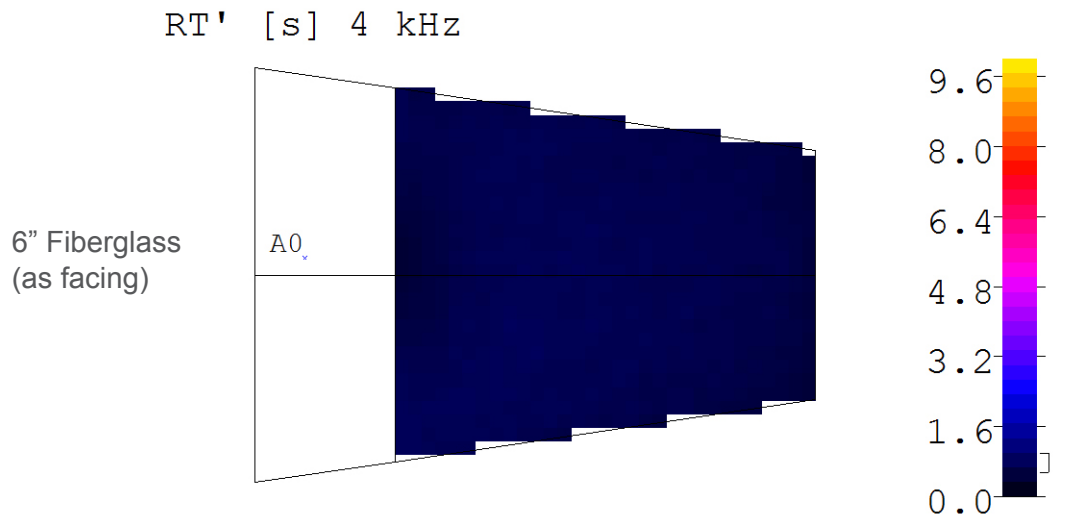

Relative Strength in decibels at 4000 Hz

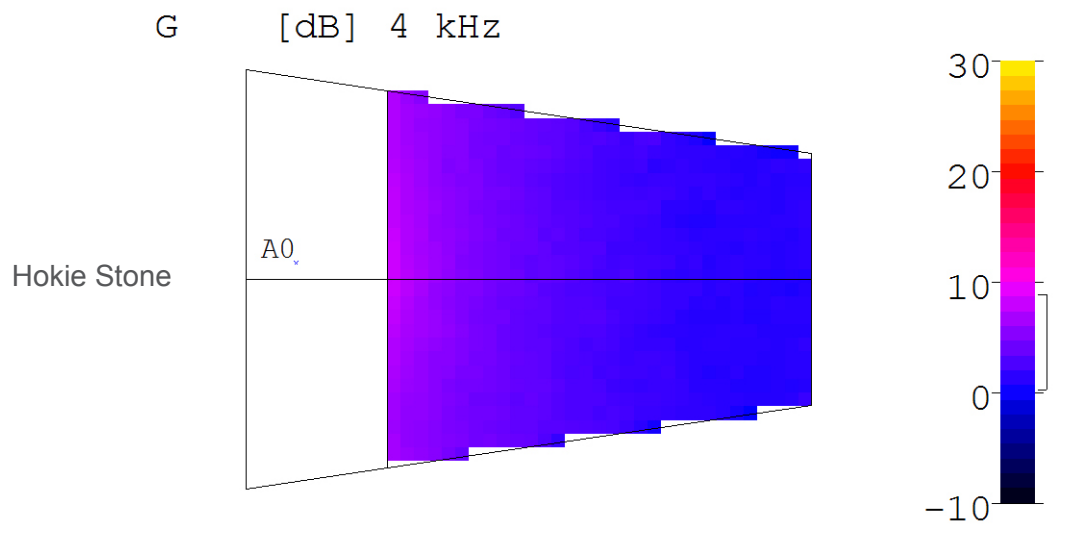
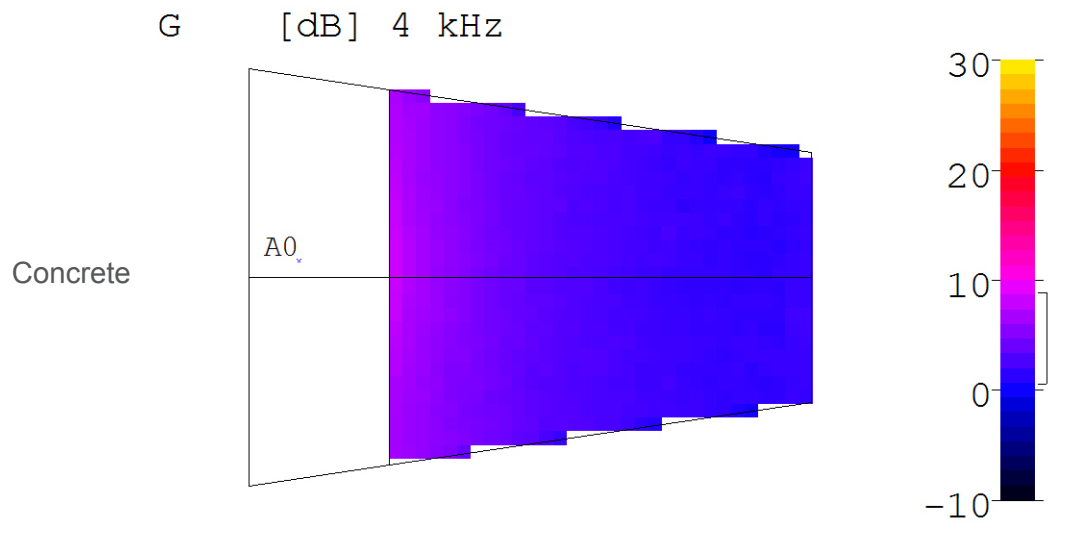
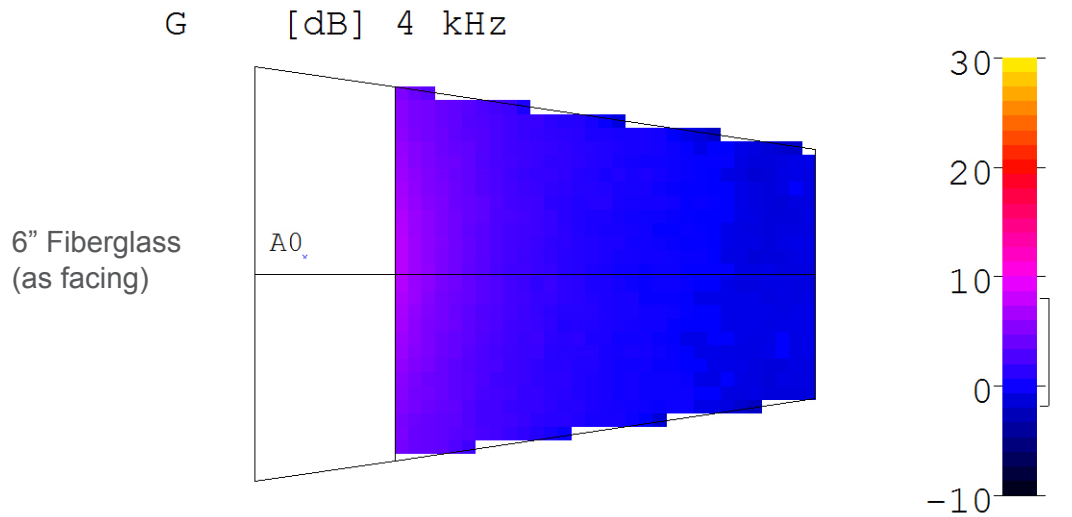

Sound Pressure Level in decibels at 4000 Hz

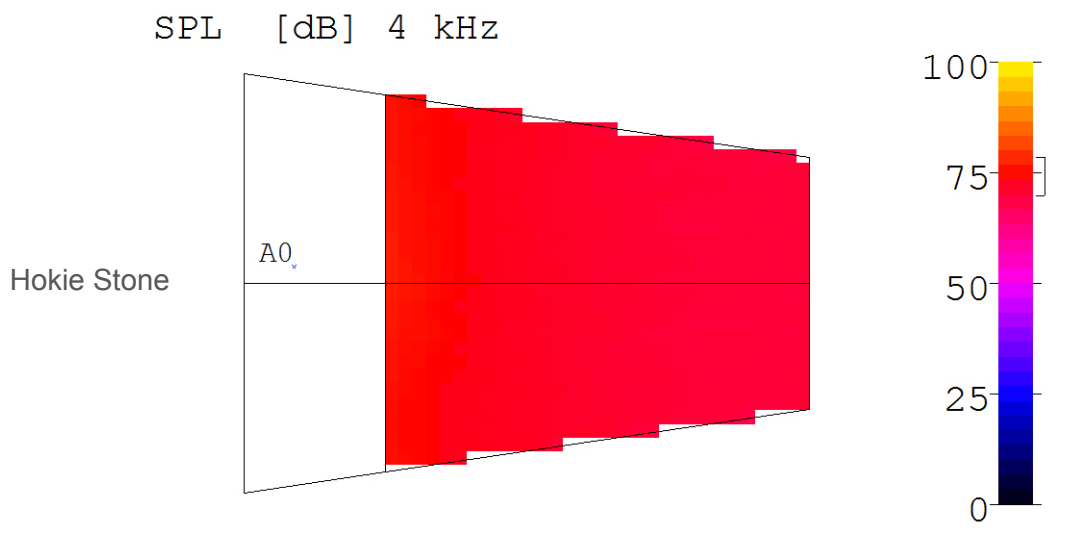
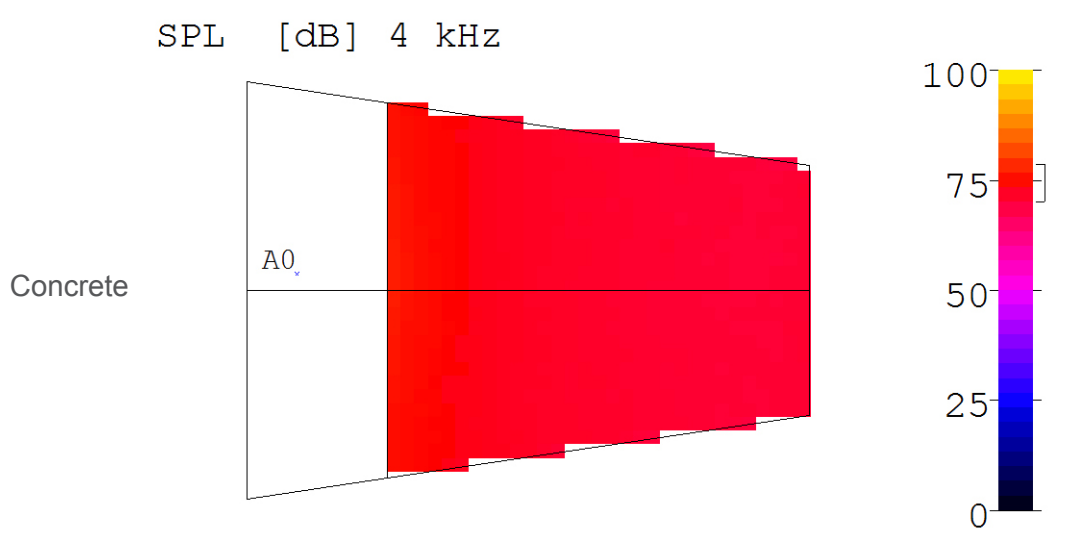
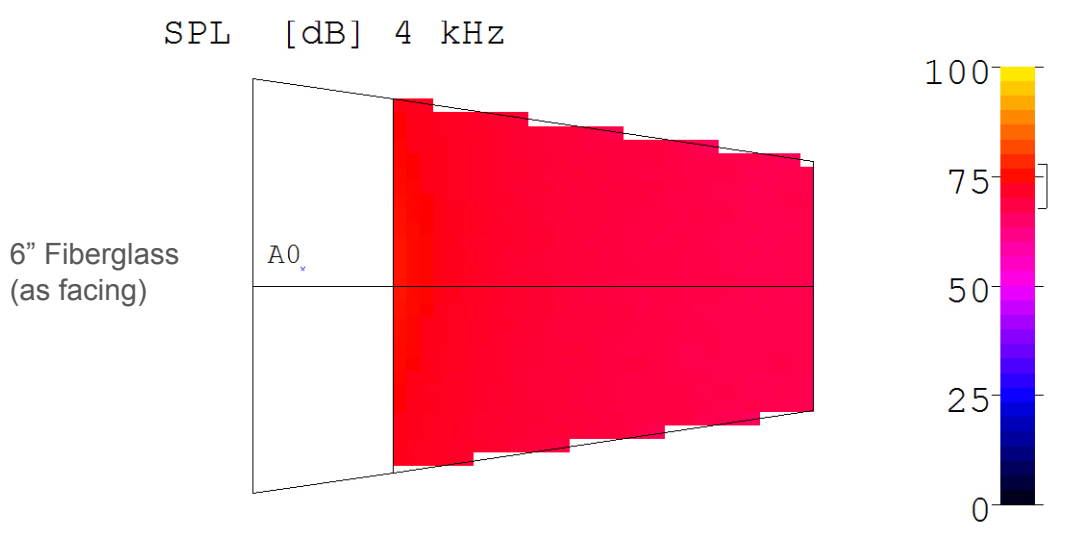

Lateral Fraction Percentage at 4000 Hz

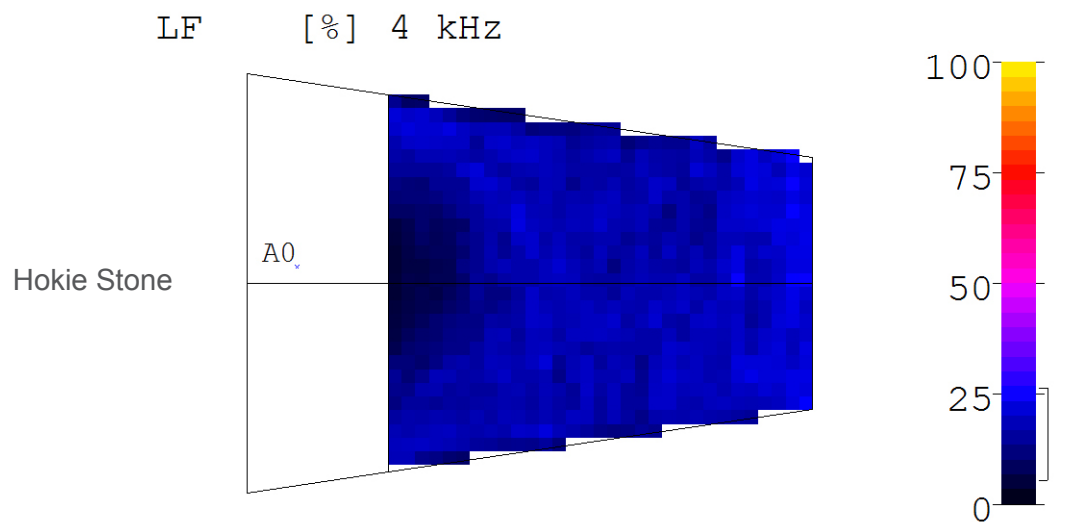
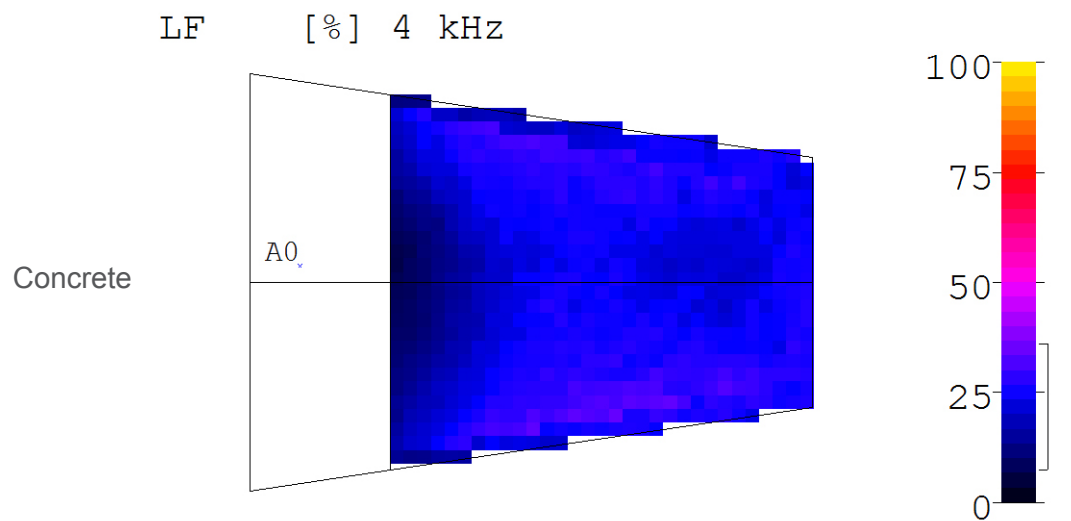
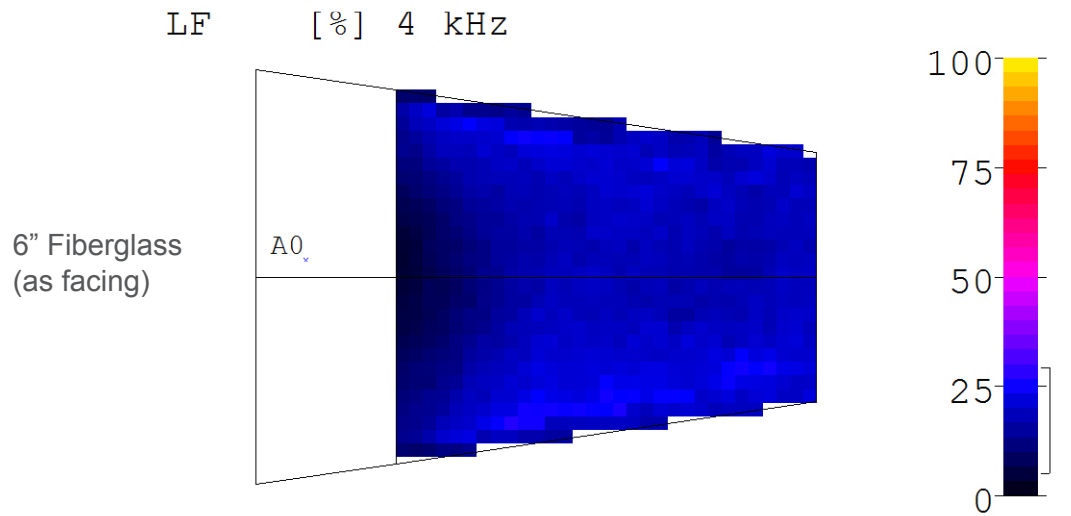

The acoustic simulation reveals that concrete outperforms walls that ‘absorb’, like fiberglass (in this case). Lateral fraction becomes lesser with the use of more absorptive materials for walls. This heightens the importance of using a material that absorbs the least, or in other words, reflects almost all of the sound.

The more intricate part of the analysis is the difference in the acoustics of the space with the use of hokie stone instead of concrete. Hokie stone diffuses almost none of the low frequency sound, some of the mid frequency sound and all of the high frequency sound, because of its dimensions with reference to the wavelengths of low, mid and high frequency sounds. The simulation reveals that clarity index, reverberation time, relative strength, sound pressure level, and lateral fraction remain almost the same at the 125 Hz octave band when concrete or hokie stone are used for the walls.

However, at the 4000 Hz octave band, lateral fraction decreases with use of hokie stone because of diffusion of higher frequencies of sound, despite that fact that every single stone would contribute a fraction of sound energy to each listener. The experience would be analogous to being showered with water instead of being hit with high velocity water from a hose with a narrow nozzle. The sound would be better, for the reason that acoustical glare is prevented, especially when several first violinists might play on the ‘e’ string, at the seventh or eleventh positions.

Combining the interaction of low and high frequency sounds with the hokie stone walls, the overall experience in the concert hall would be better, because hokie stone contributes more low frequency sound to each listener than high frequency sounds. This results in greater ‘depth’ of sound, which is what seemed to get lost as a result of using glass in the concert hall.

At the same time, hokie stone does not ‘censor’ or absorb too much of a certain frequency: it only diffuses sound gradually: none of low frequency sound to all of high frequency sound. Hence the space would not lack ‘timbre’. The musical instruments’ natural tone color is preserved.

Apart from the walls, the acoustics of the hall is not only influenced by the materials used for ceilings, but also the manner in which the various building systems are integrated with it.

The next few pages are acoustic simulations of three ceilings:

1. 6” Fiberglass (as facing)
2. Concrete (flat)
3. Concrete (with integrated building systems as coupled volume)

Clarity Index in decibels at 125 Hz

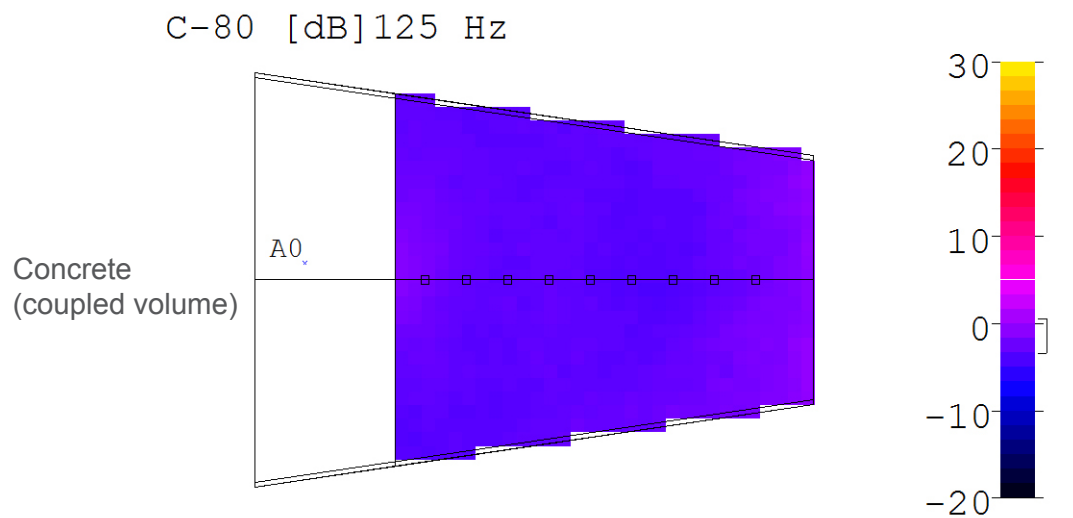
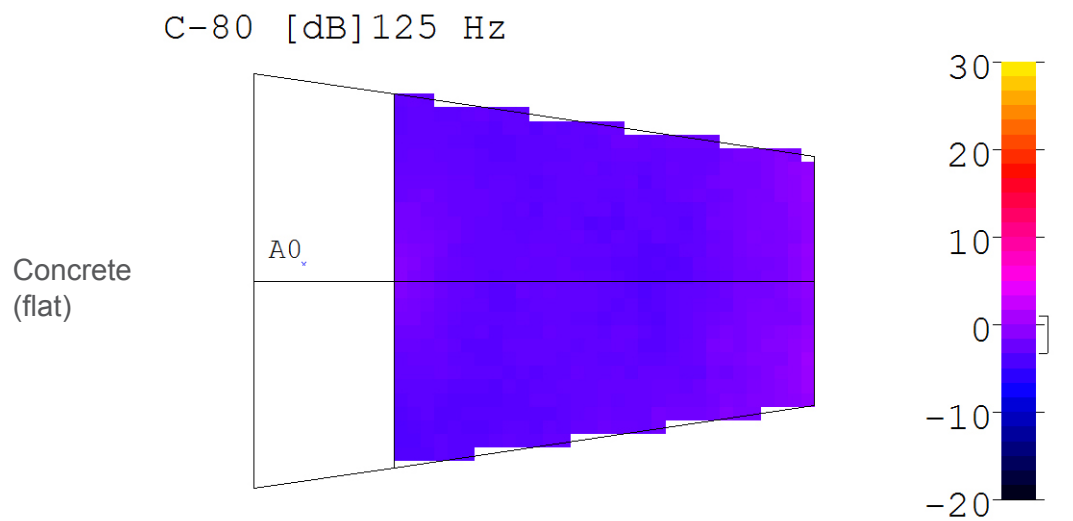
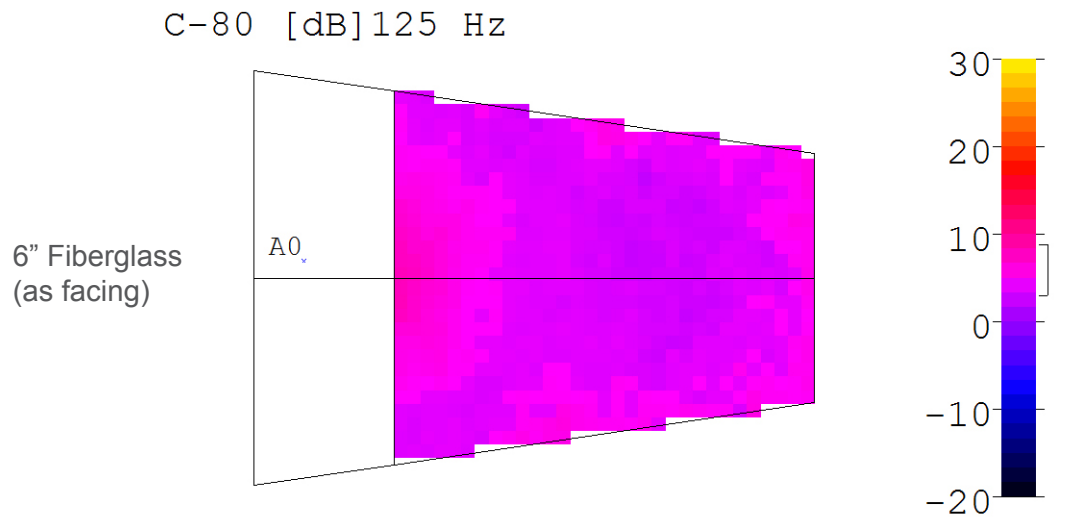

Reverberation Time in seconds at 125 Hz

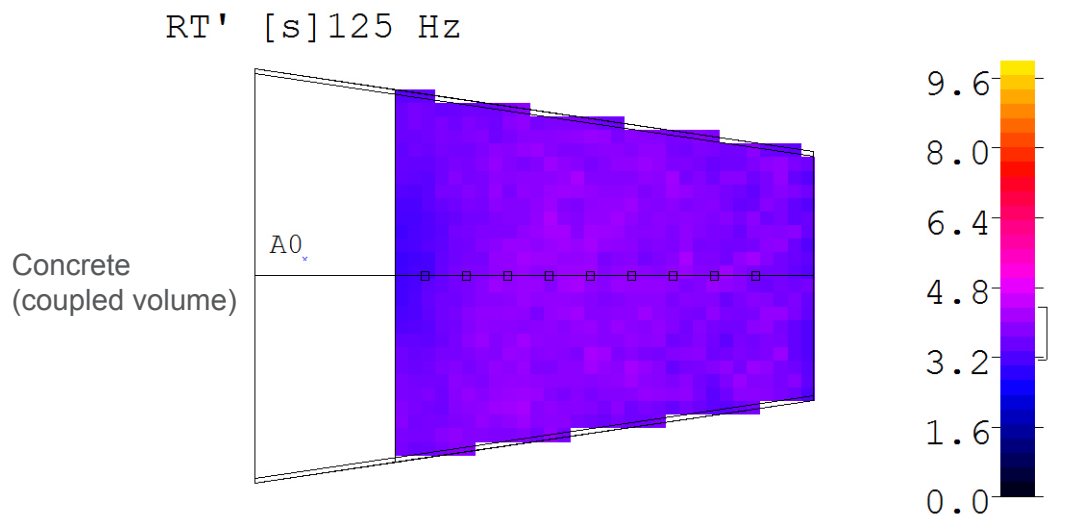
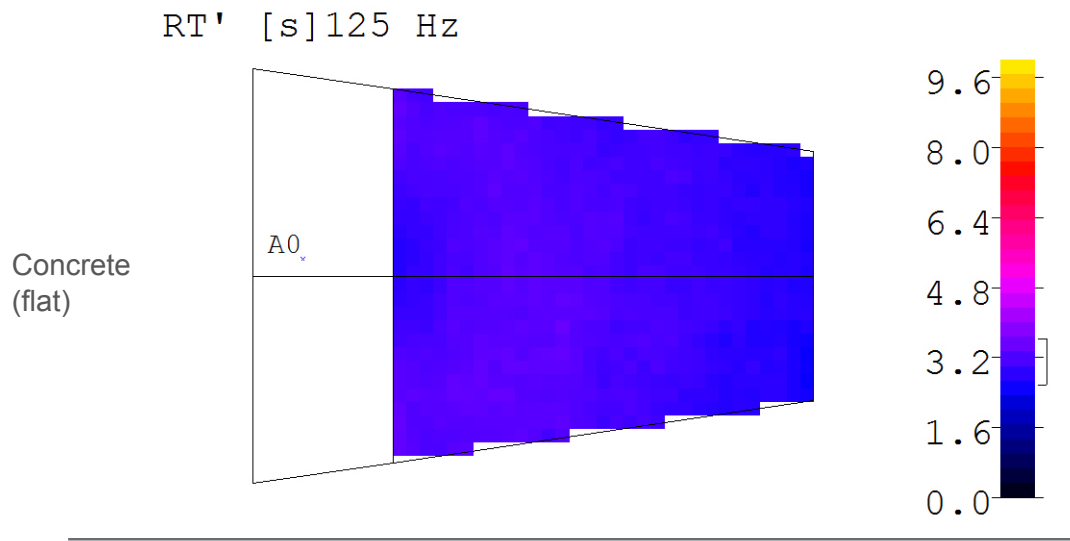
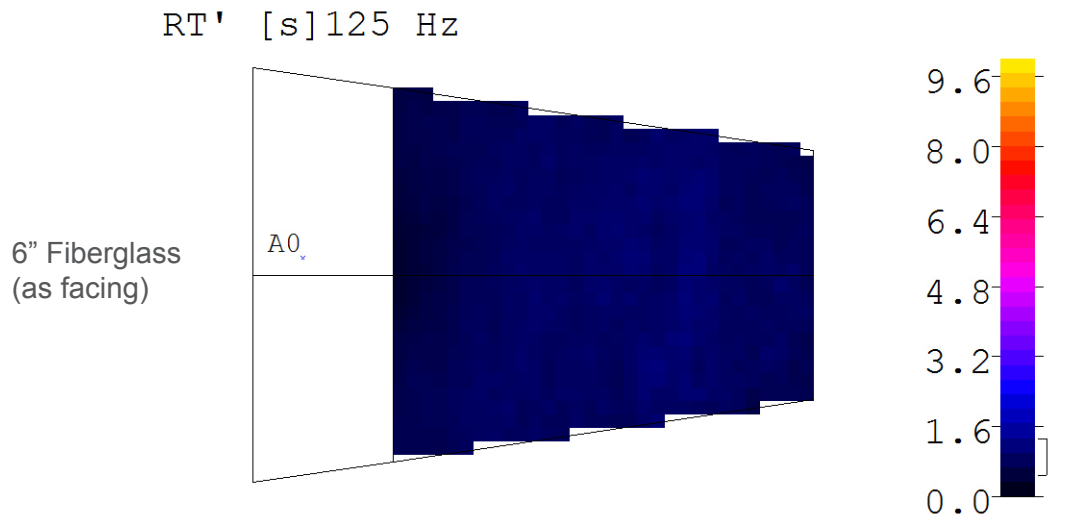

Relative Strength in decibels at 125 Hz

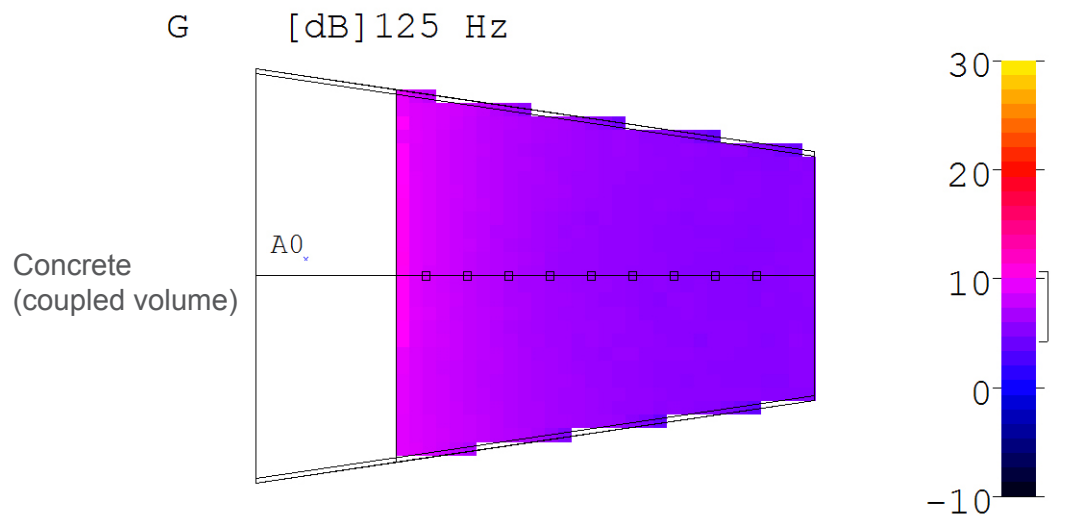
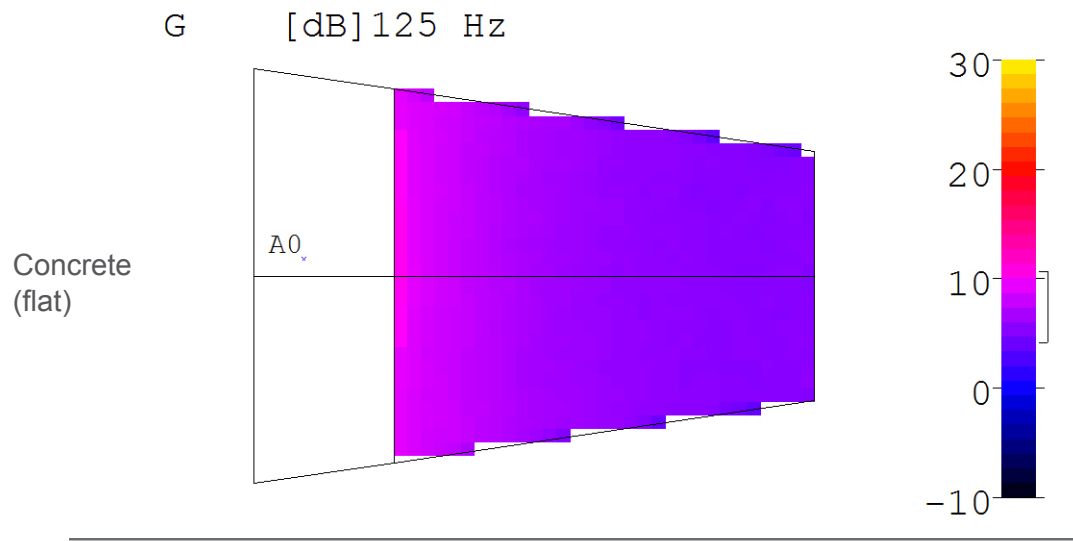
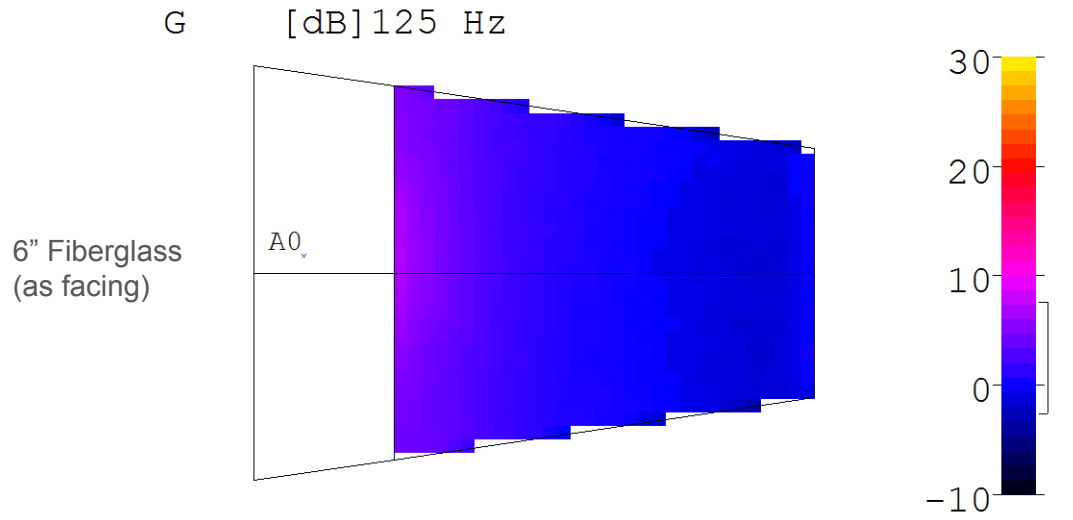

Sound Pressure Level in decibels at 125 Hz

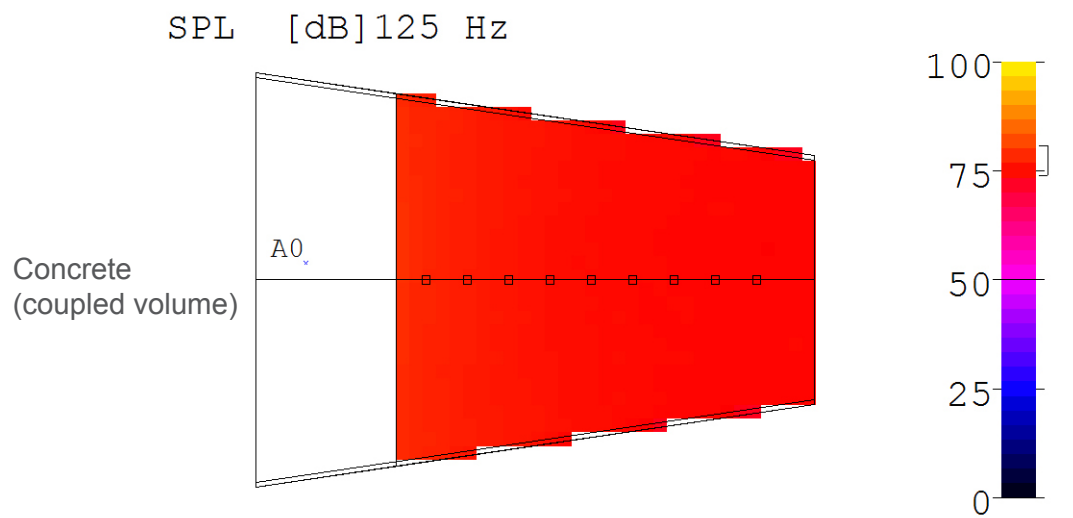
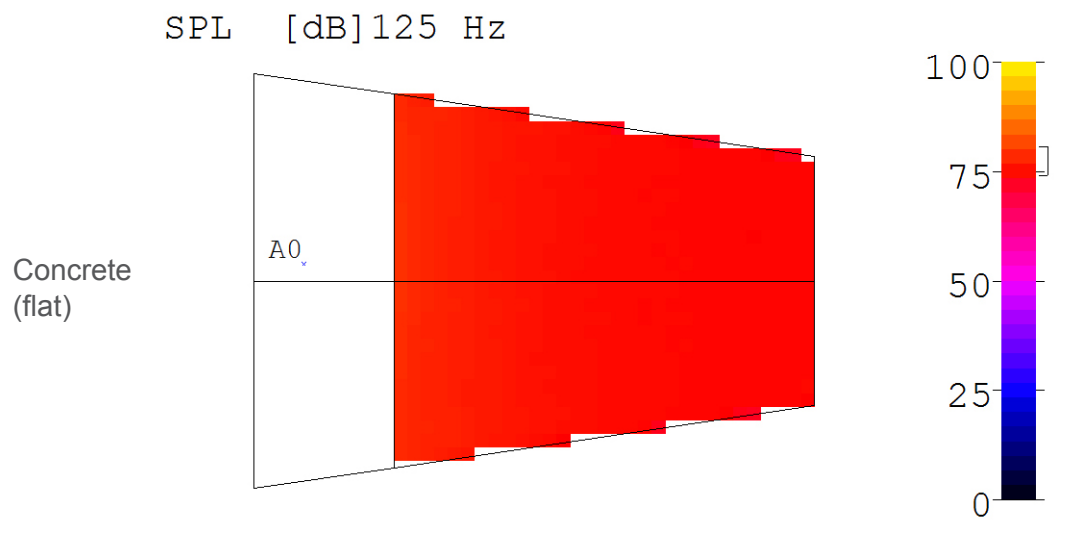
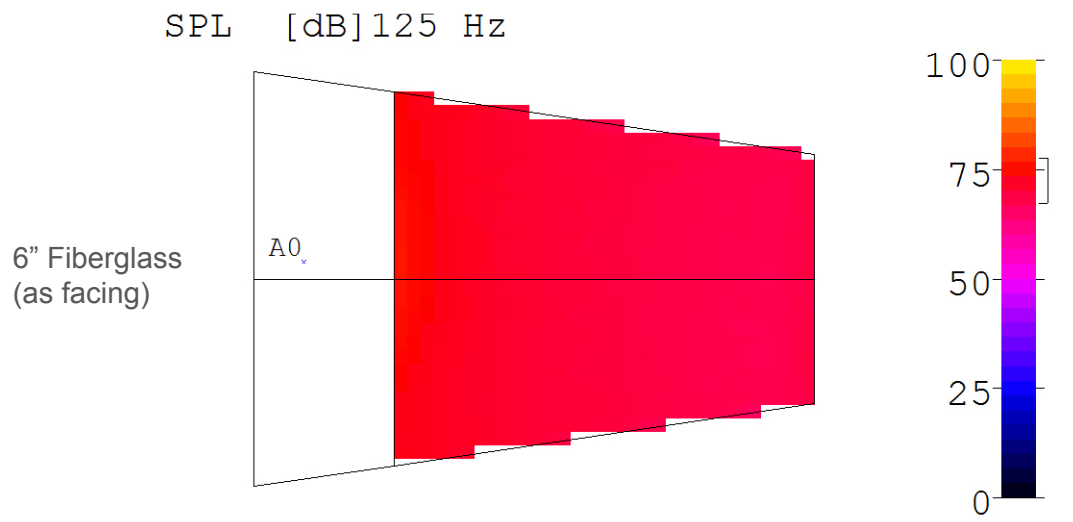

Lateral Fraction Percentage at 125 Hz

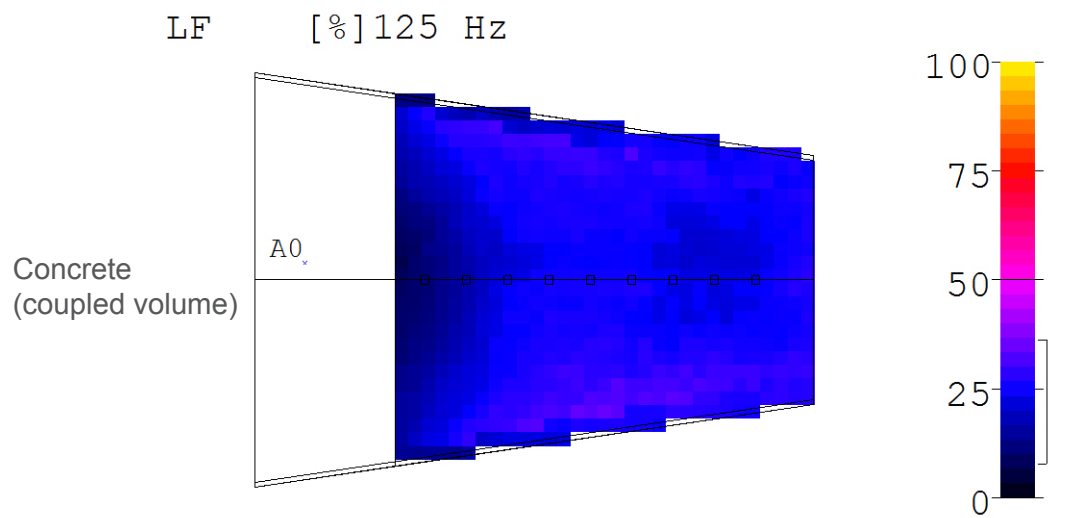
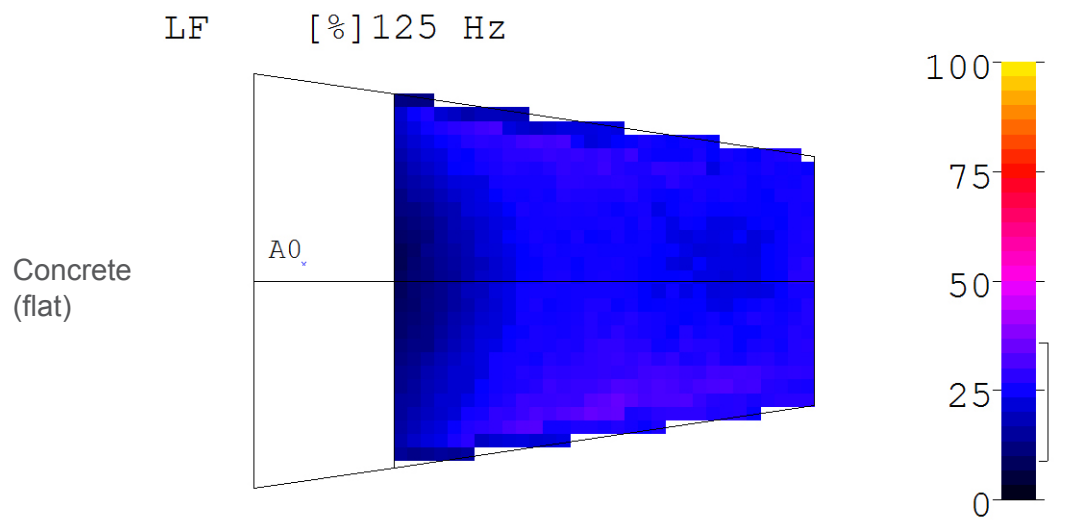
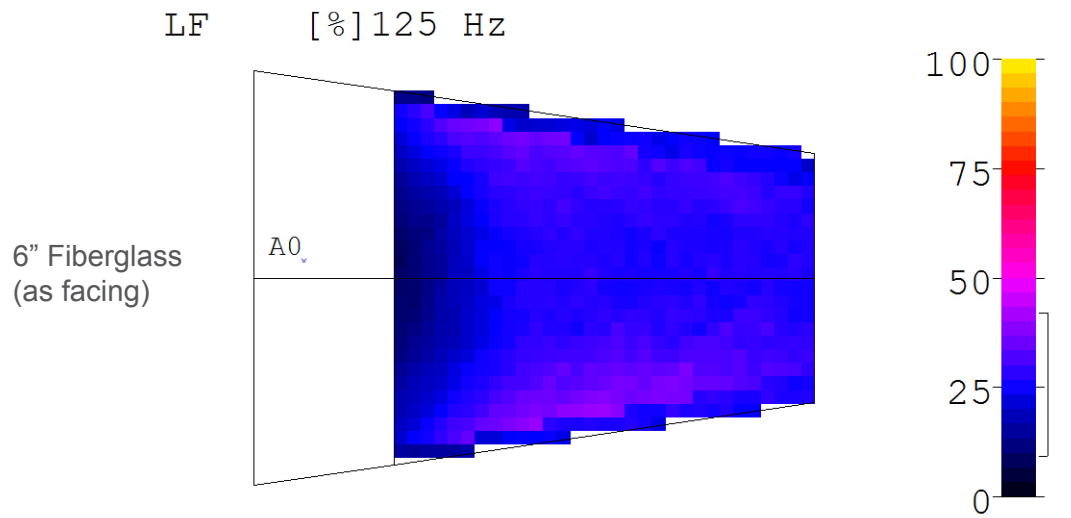

Clarity Index in decibels at 500 Hz

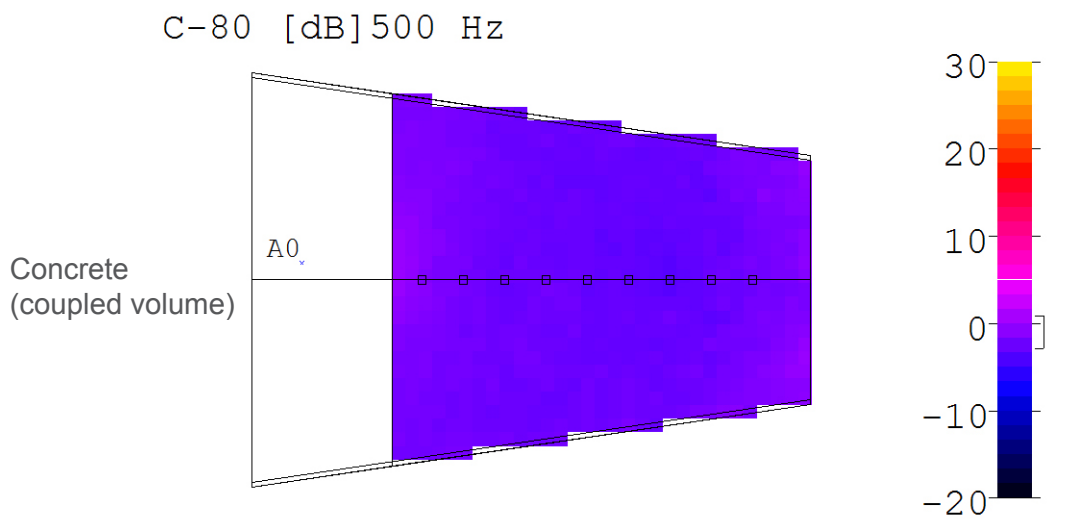
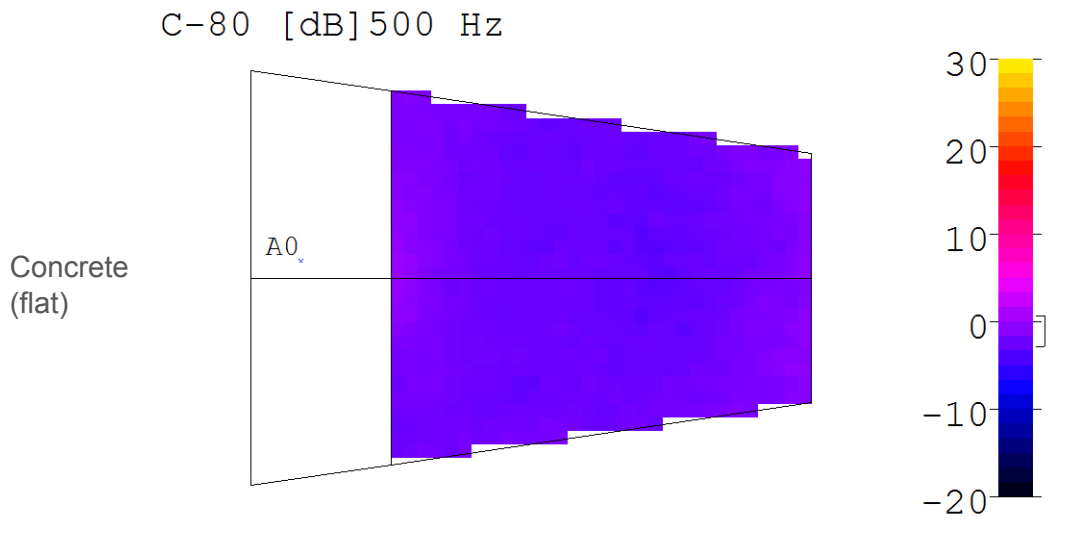
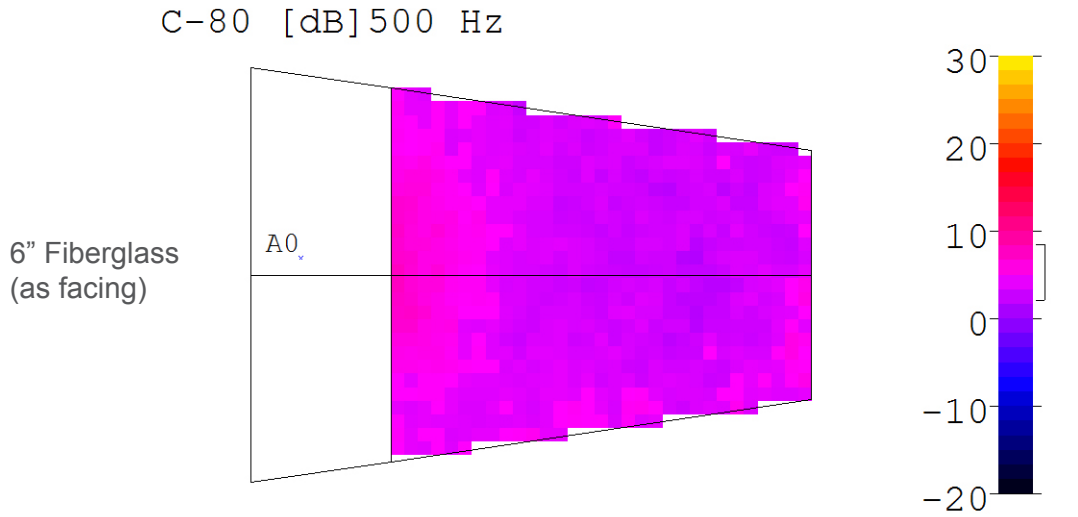

Reverberation Time in seconds at 500 Hz

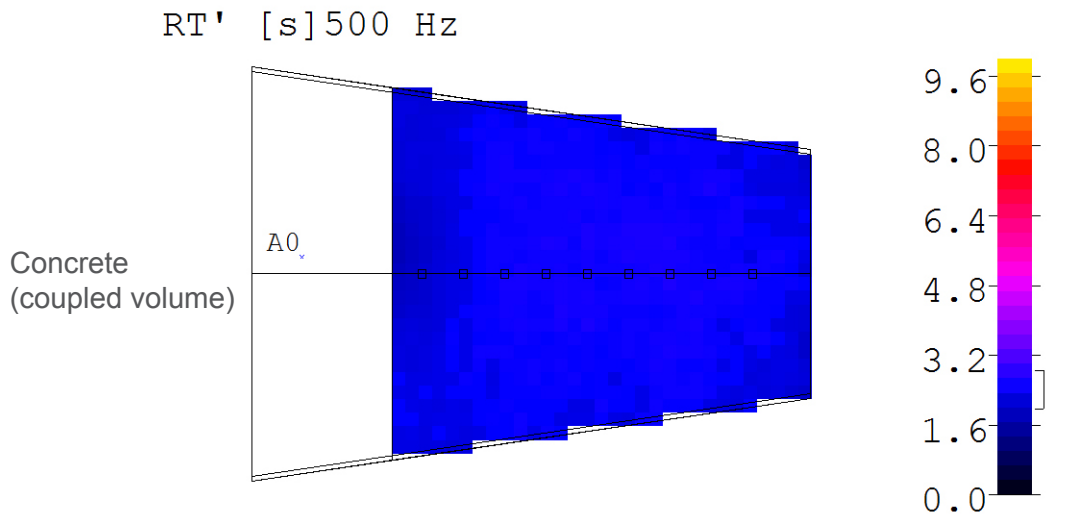
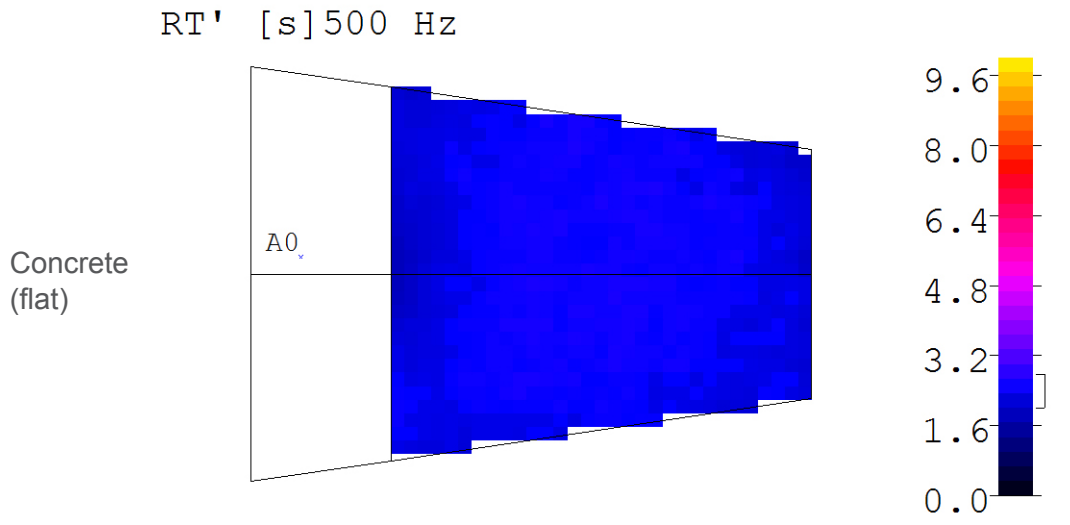
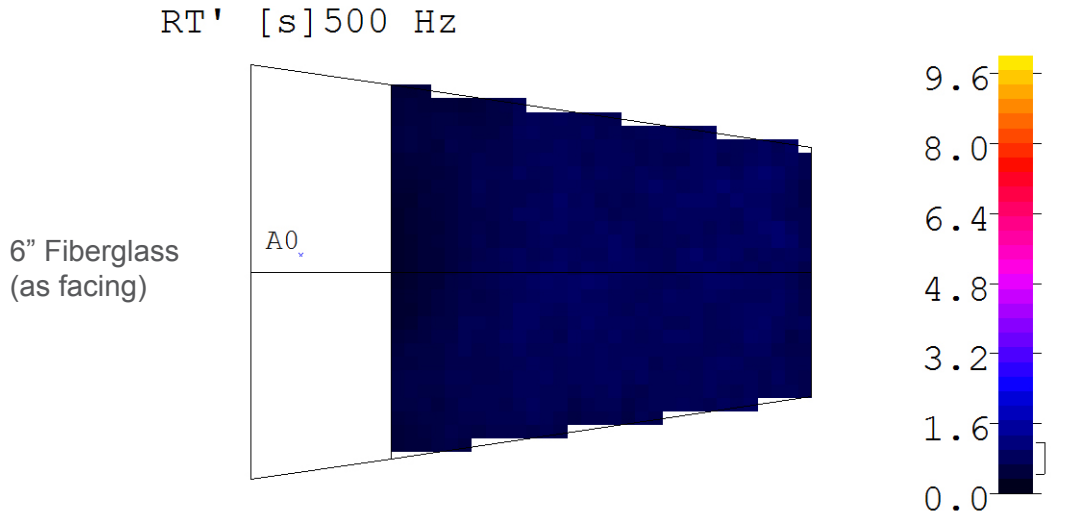

Relative Strength in decibels at 500 Hz

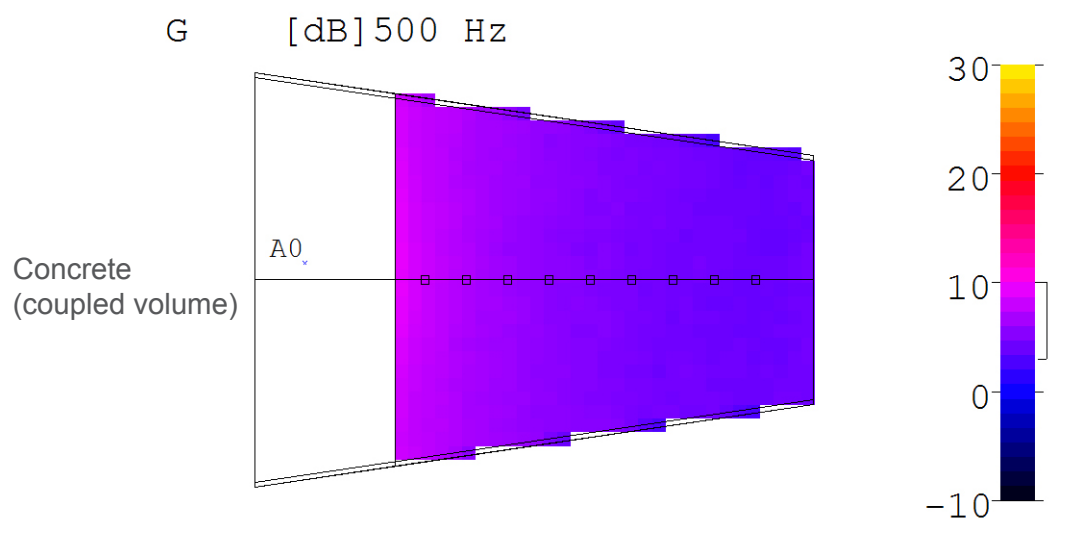
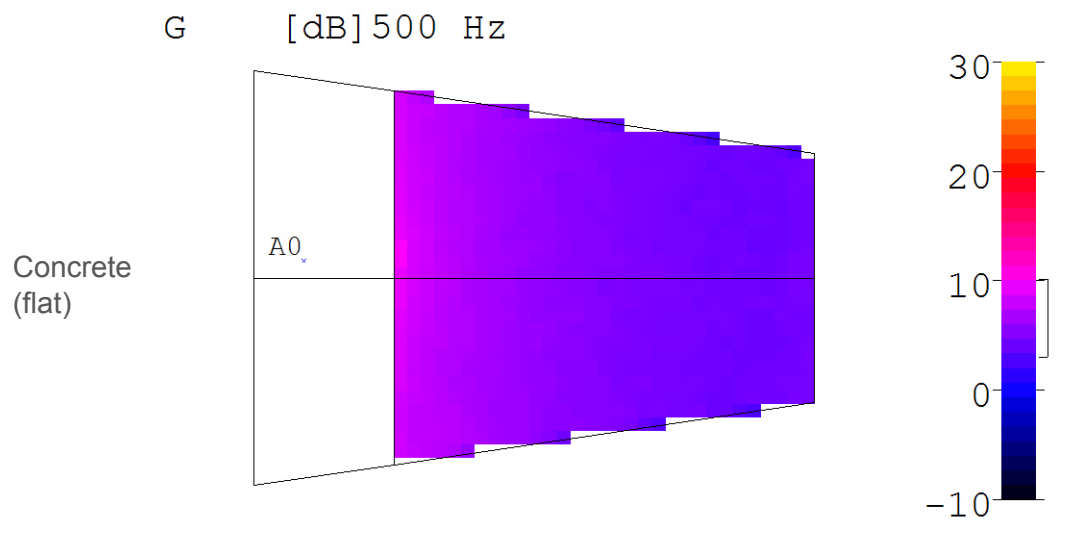
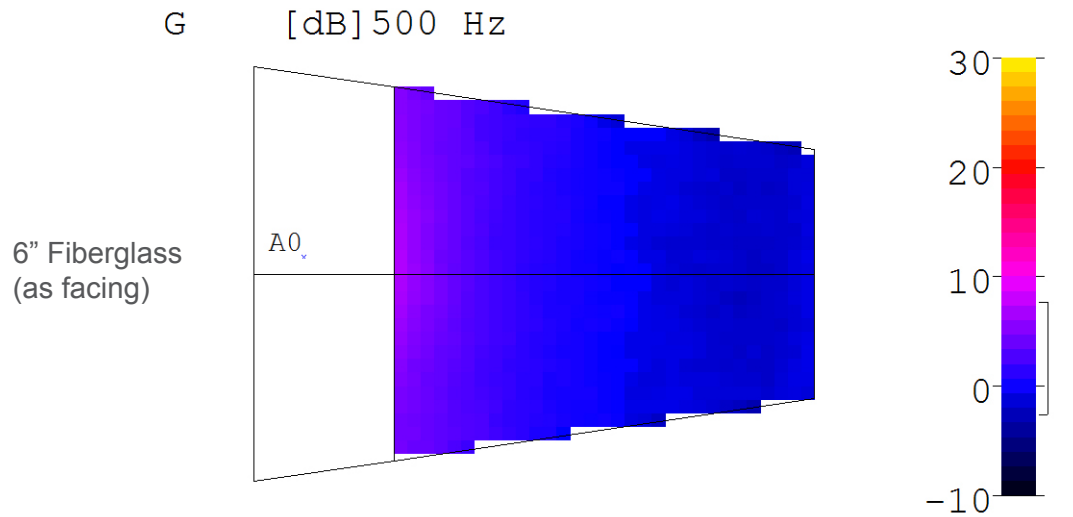

Sound Pressure Level in decibels at 500 Hz

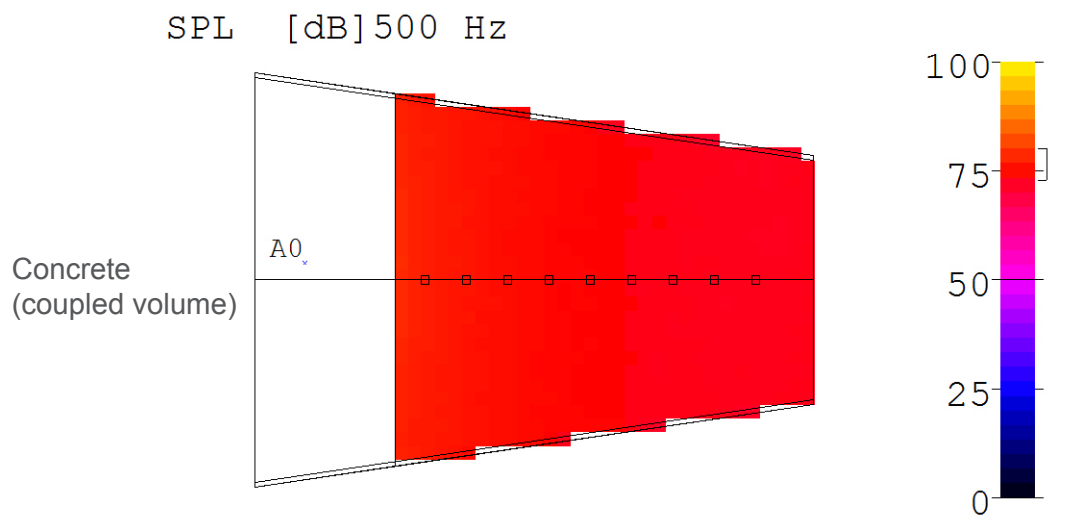
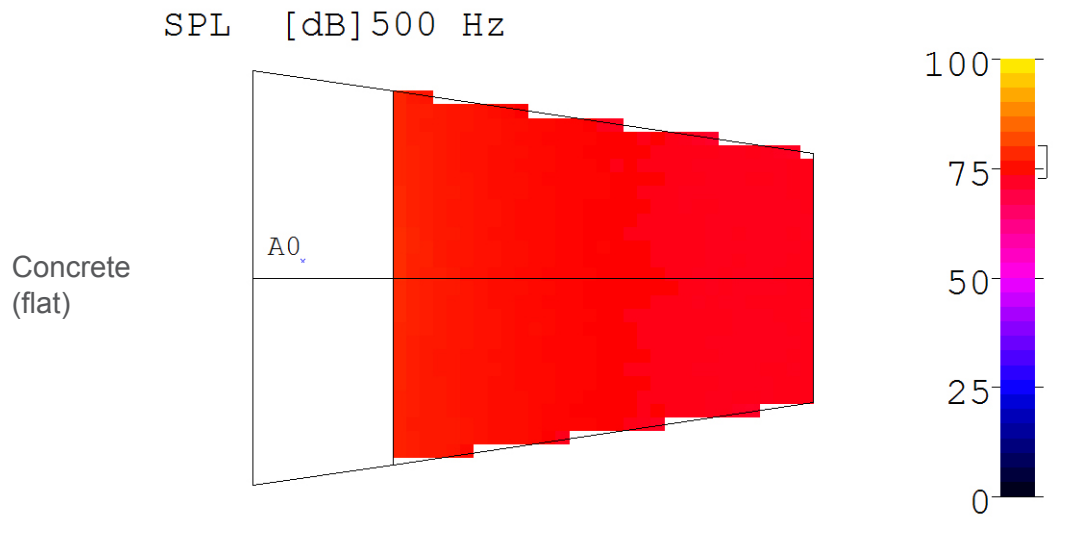
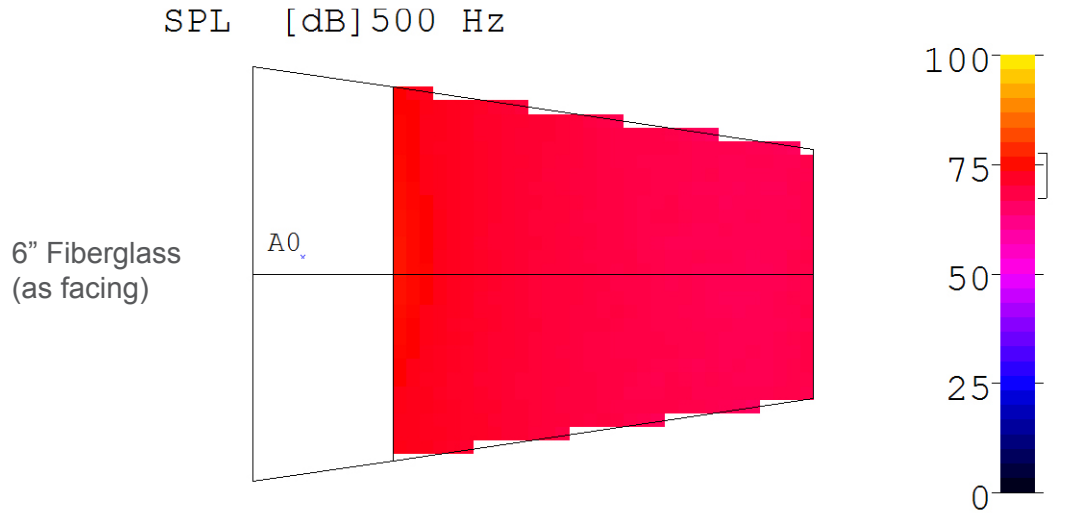

Lateral Fraction Percentage at 500 Hz

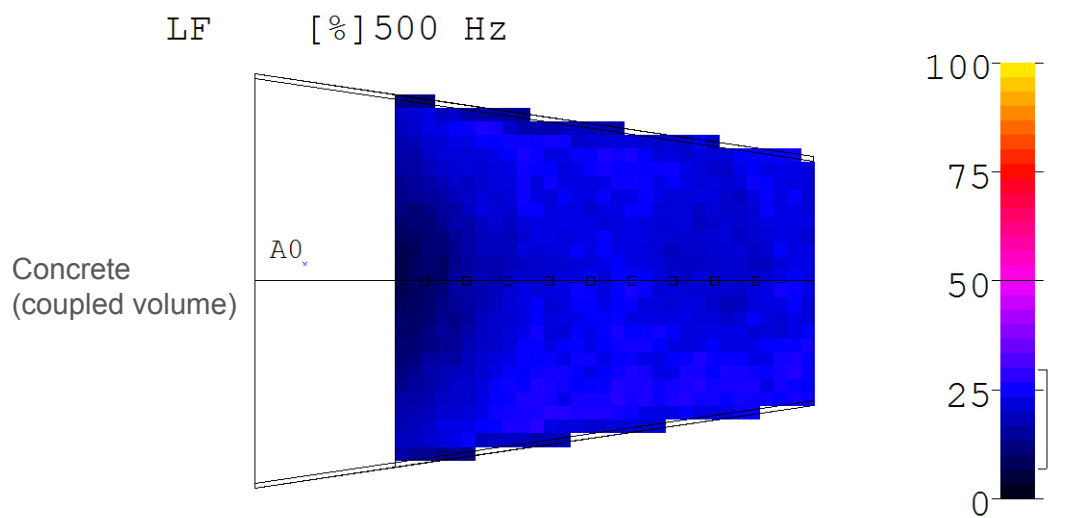
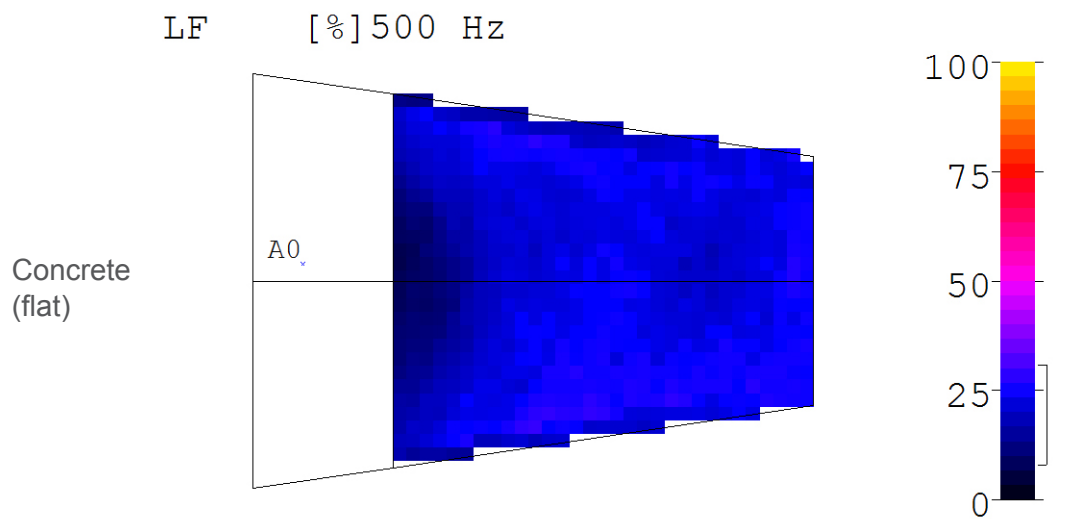
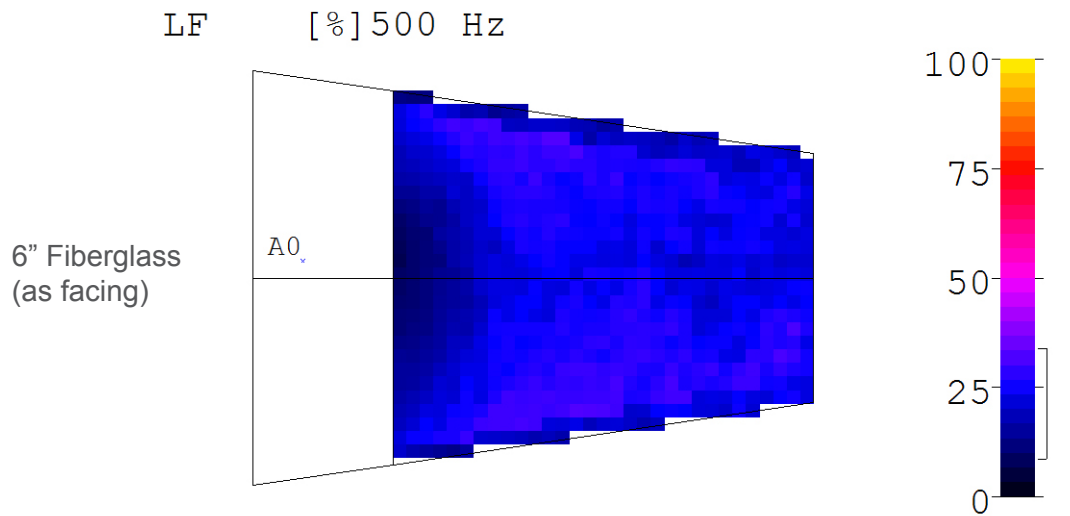

Clarity Index in decibels at 4000 Hz

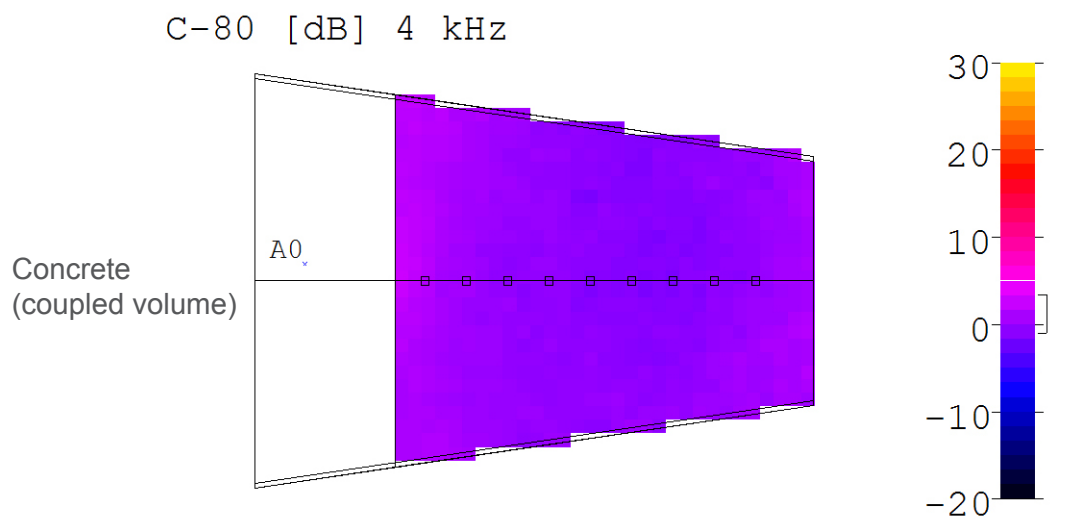
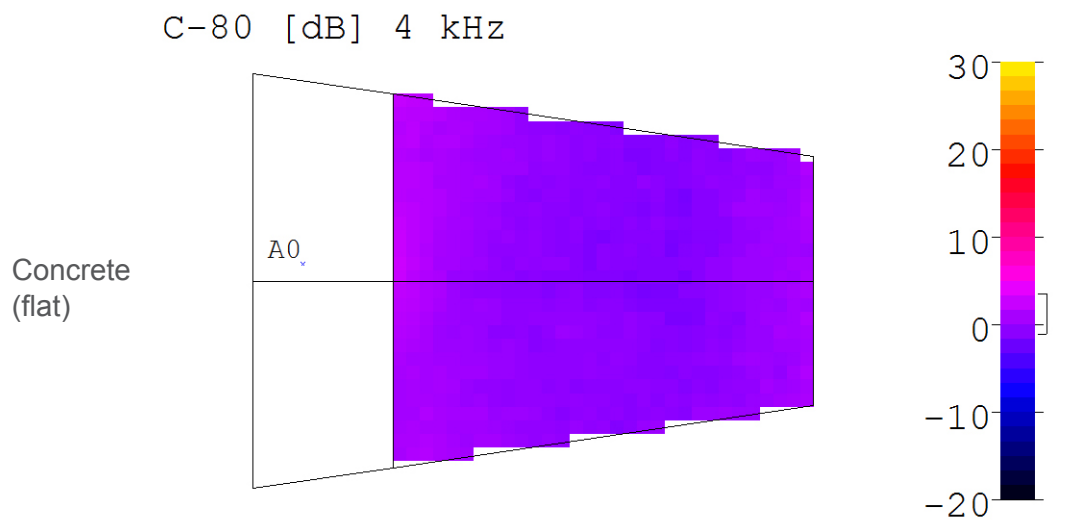
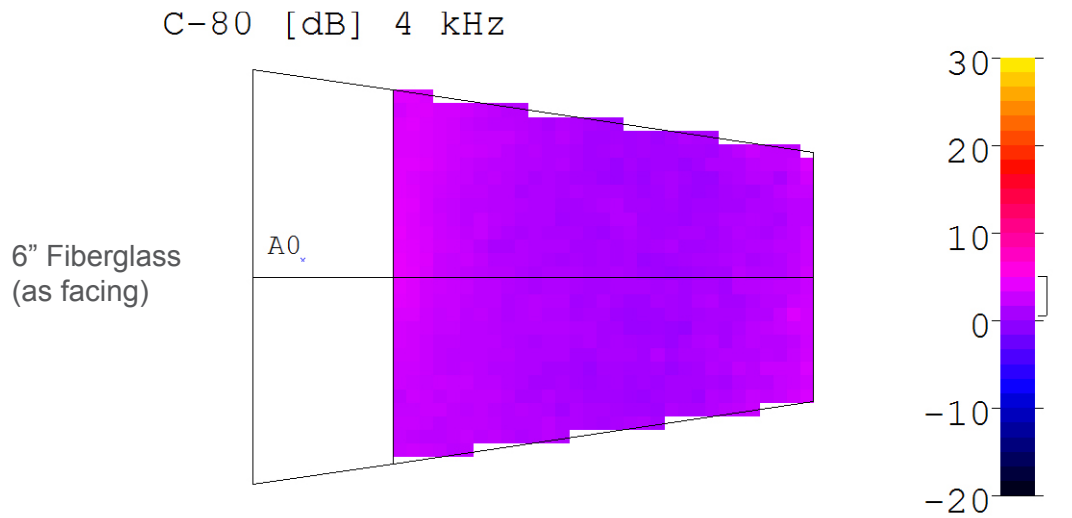

Reverberation Time in seconds at 4000 Hz

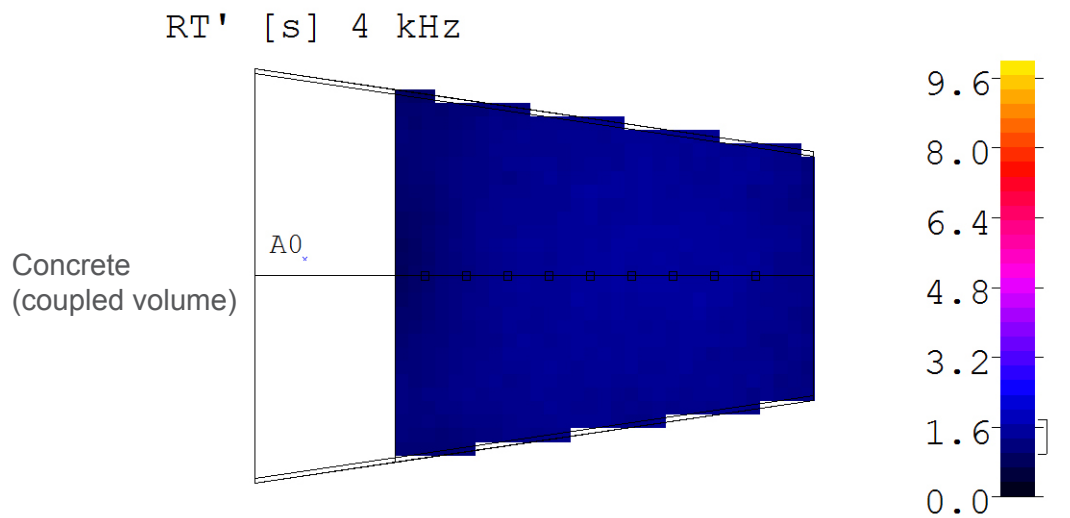
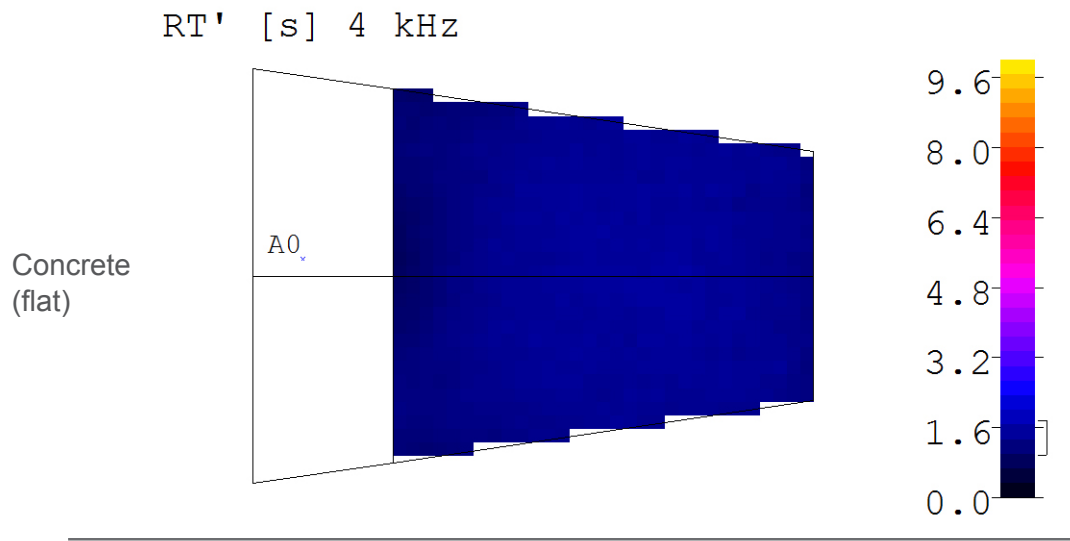
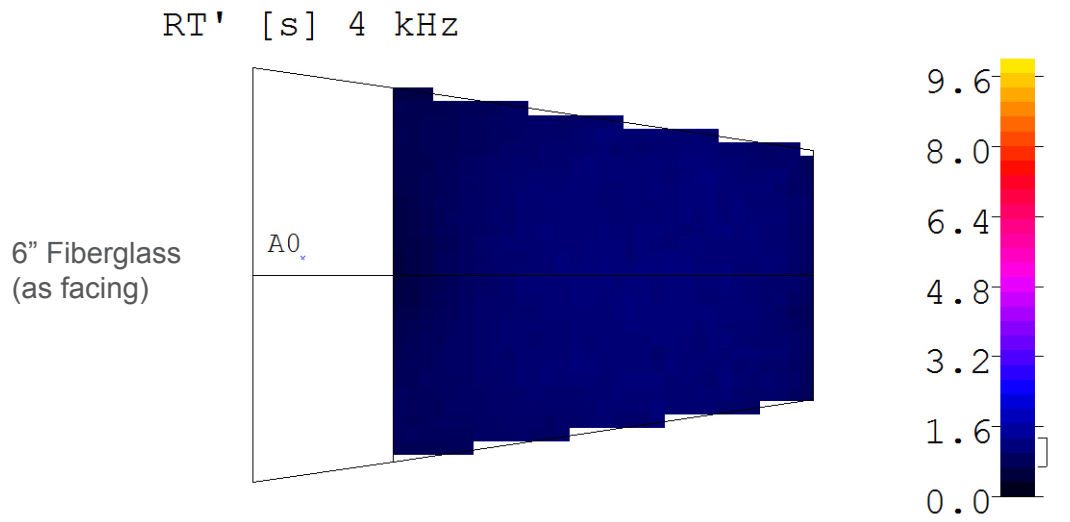

Relative Strength in decibels at 4000 Hz

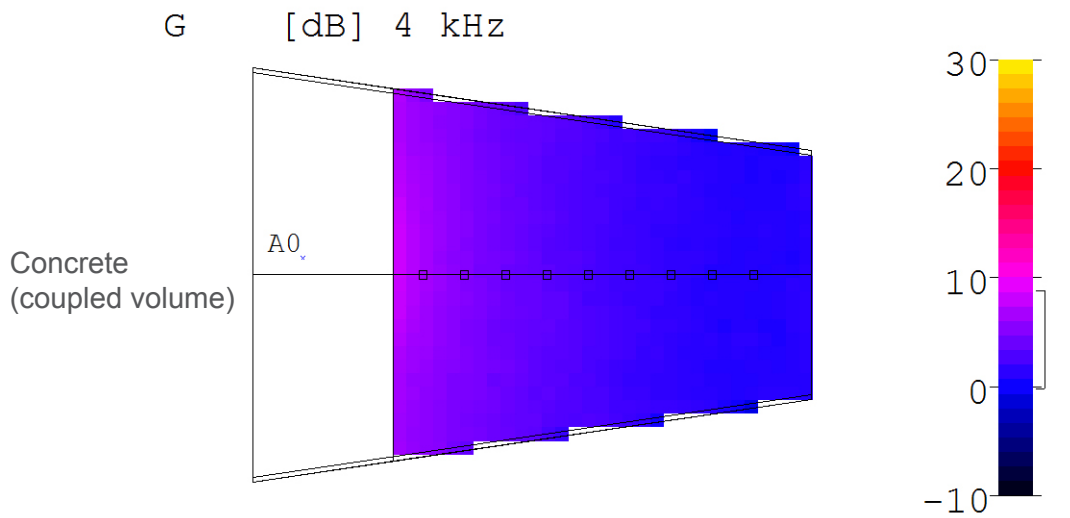
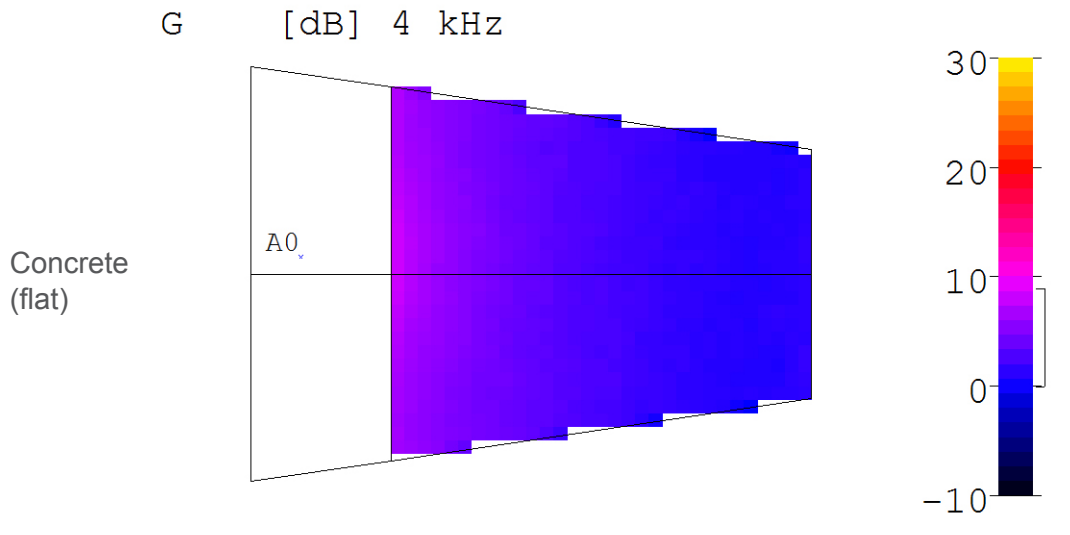
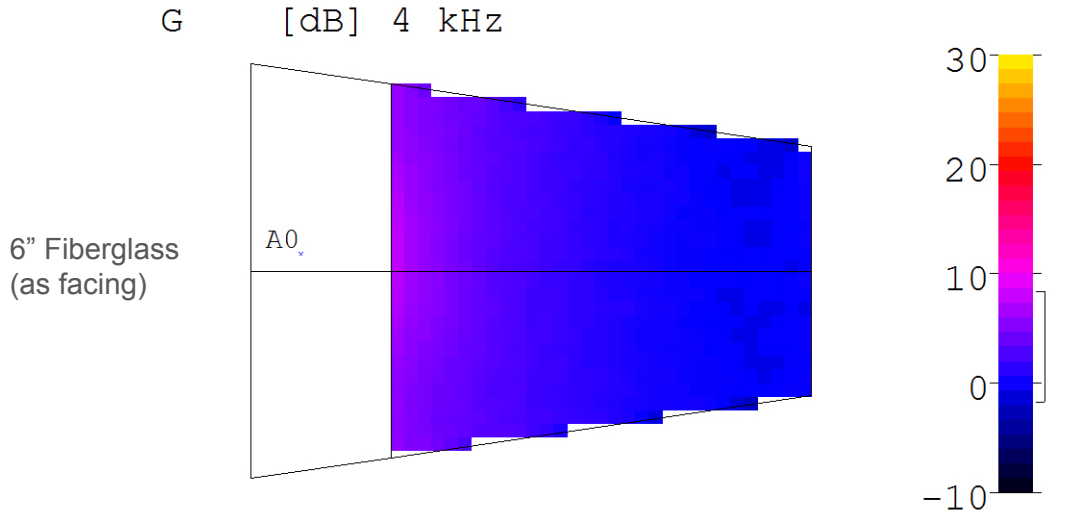

Sound Pressure Level in decibels at 4000 Hz

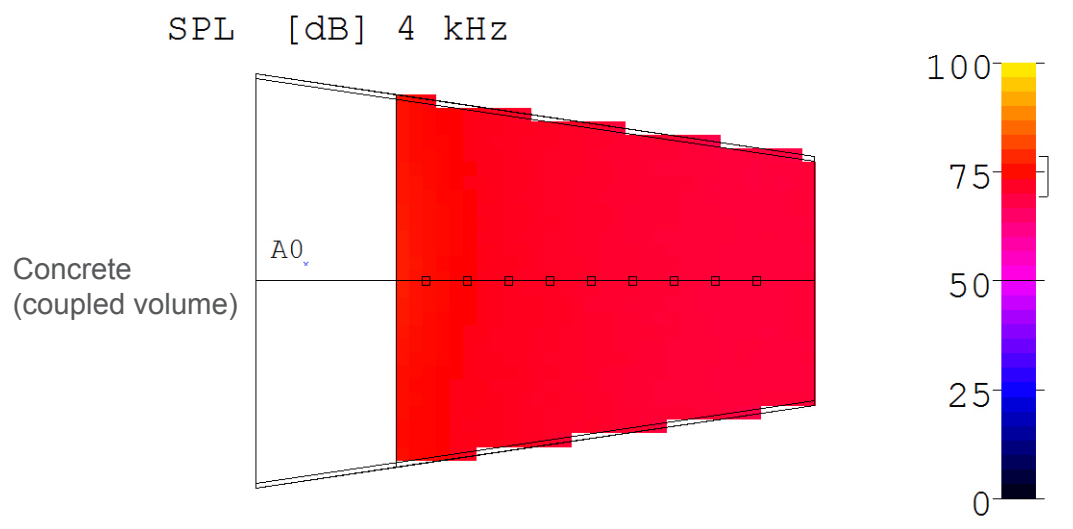
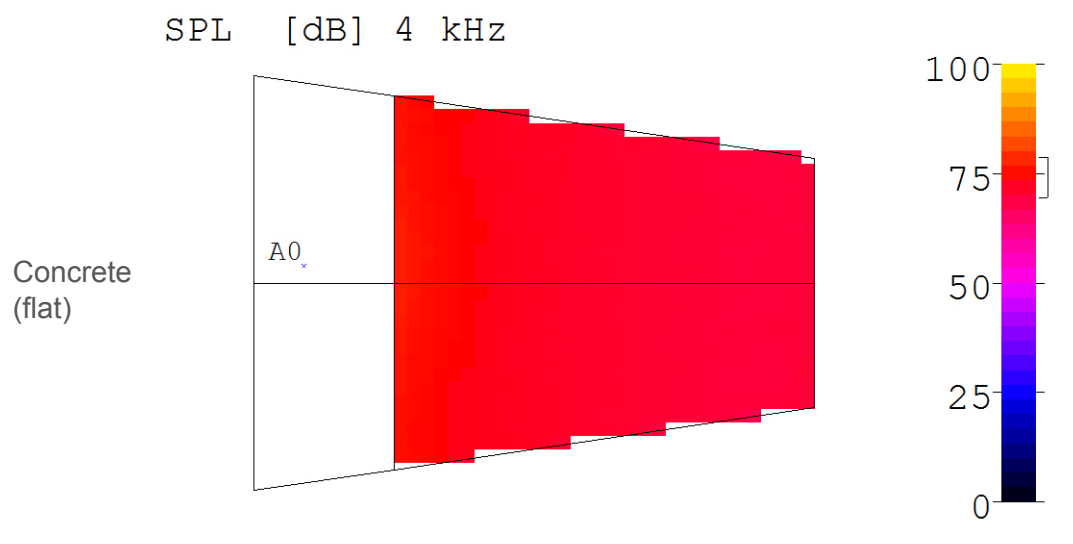
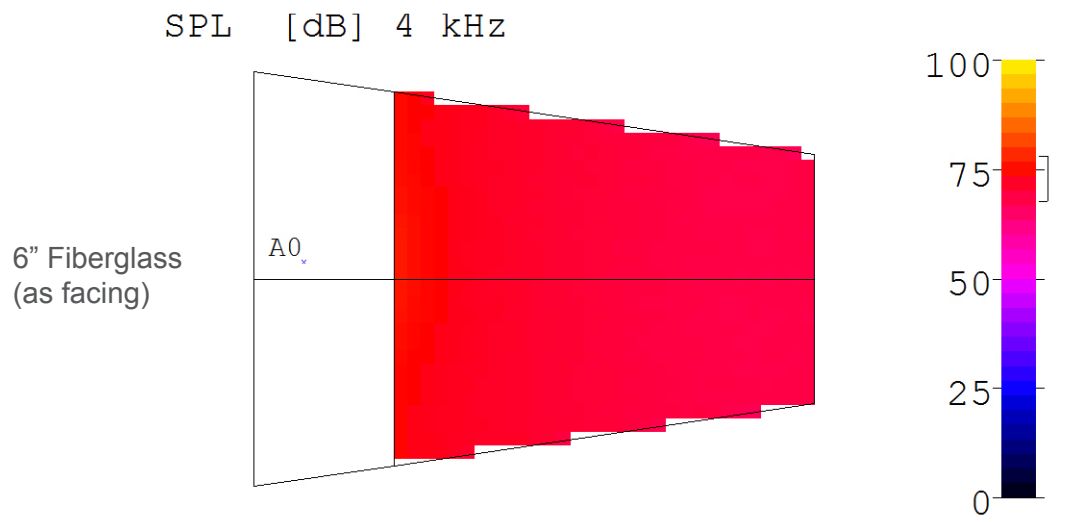

Lateral Fraction Percentage at 4000 Hz

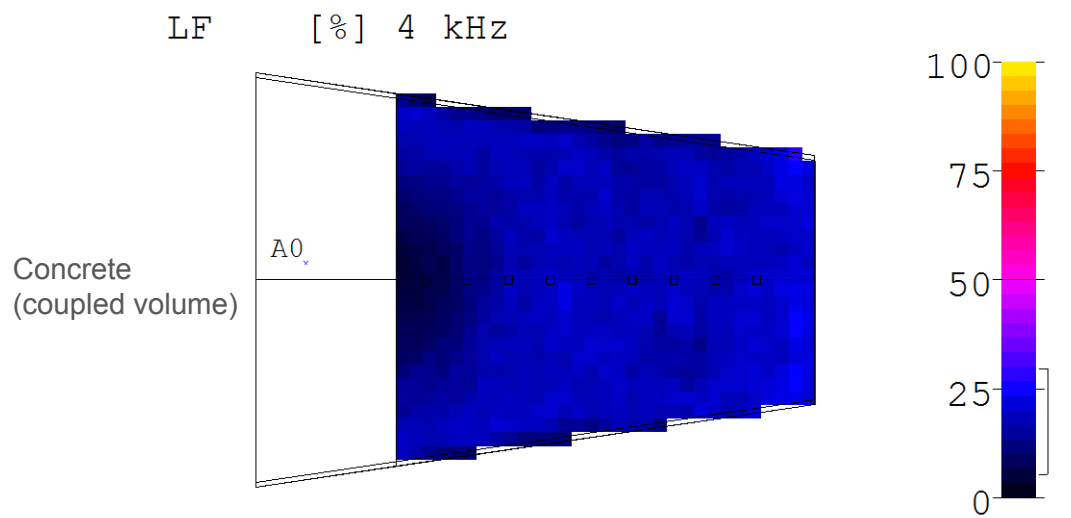
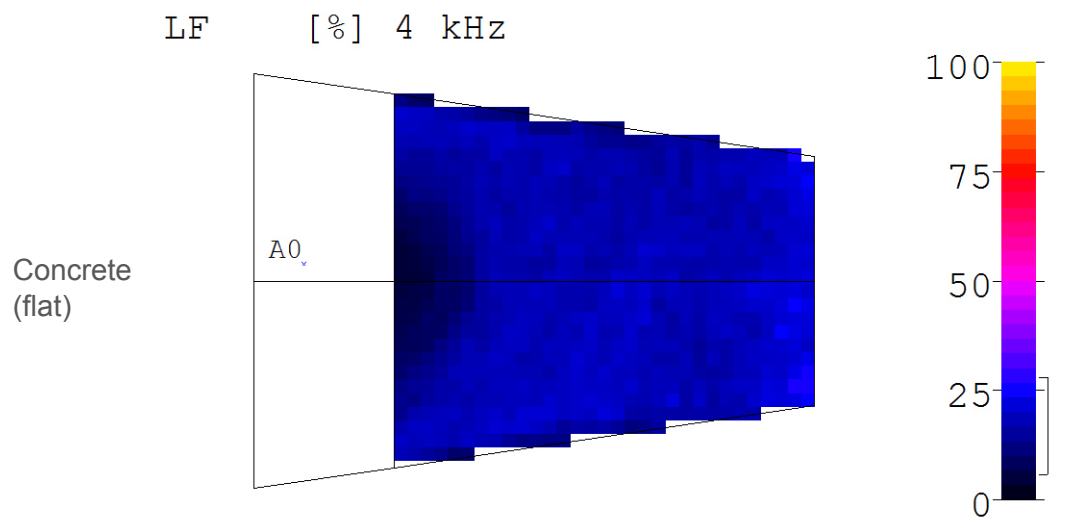
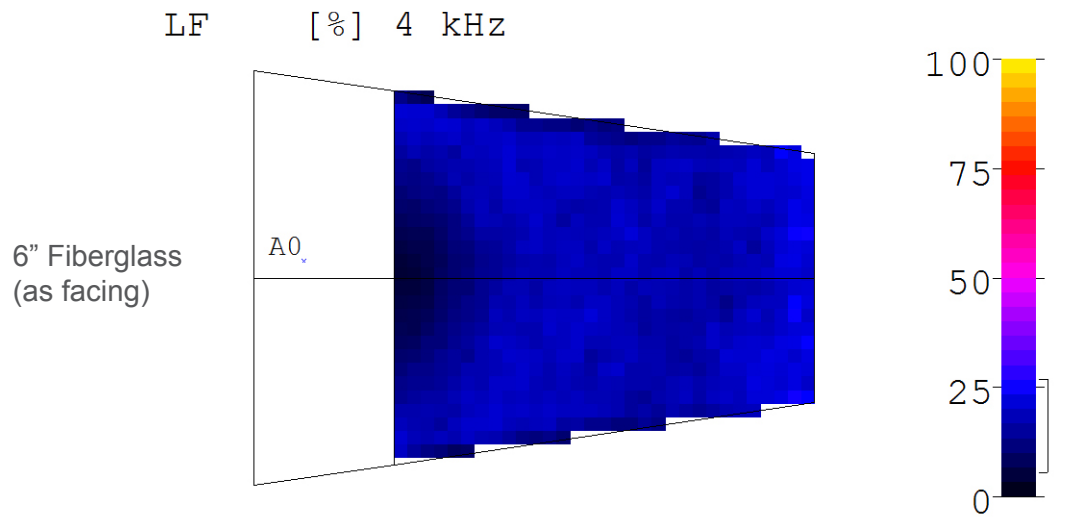

Global Reverberation Time in seconds

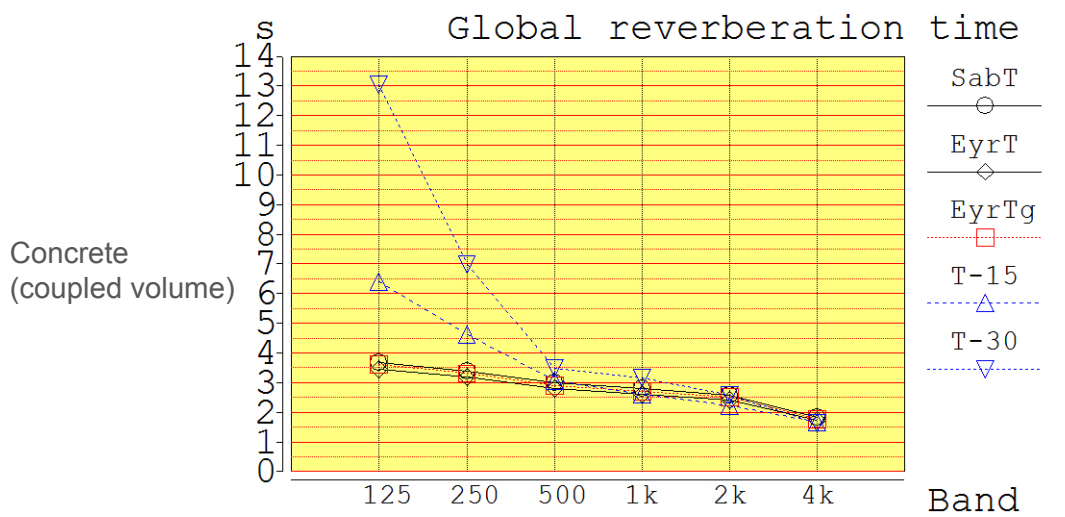
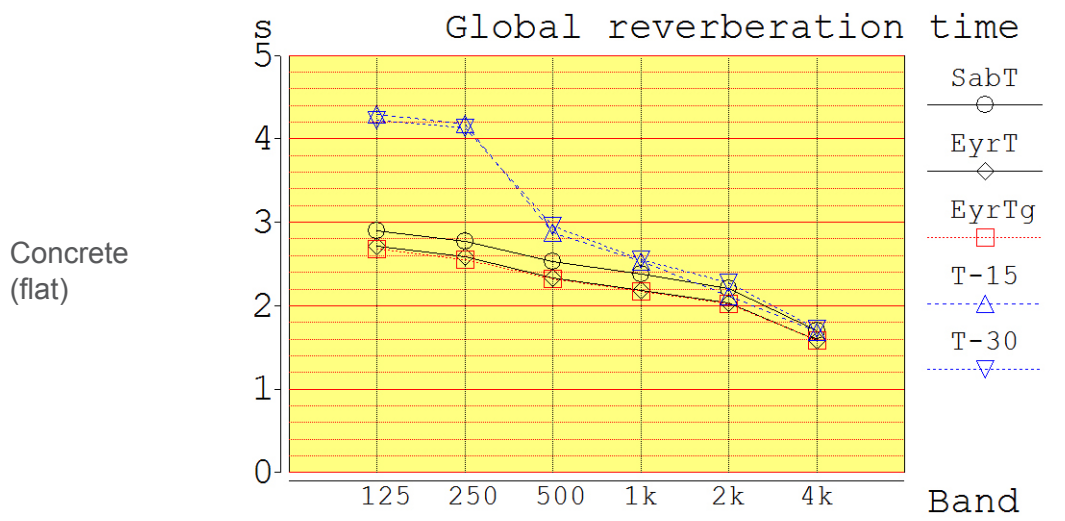
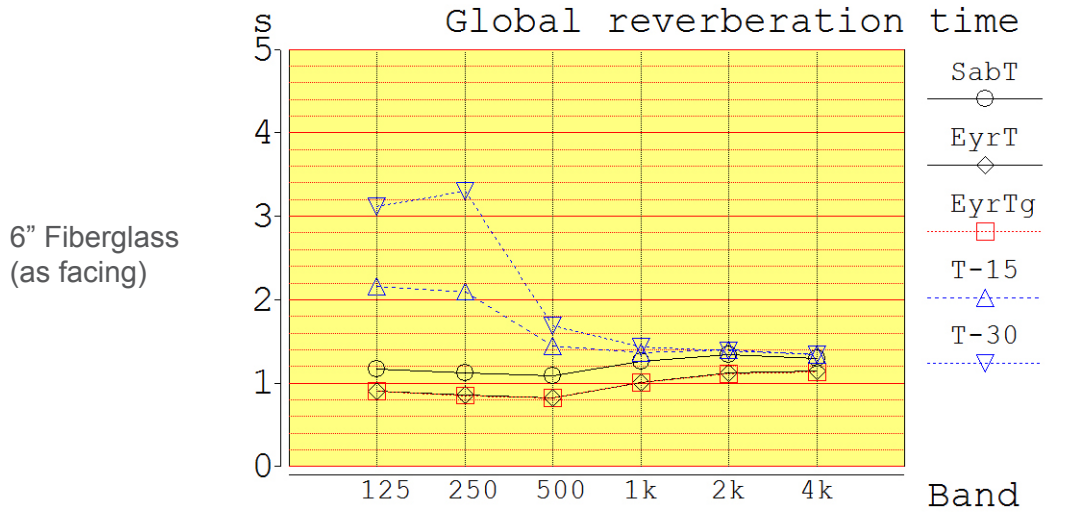

Sound Decay

6" Fiberglass
(as facing)

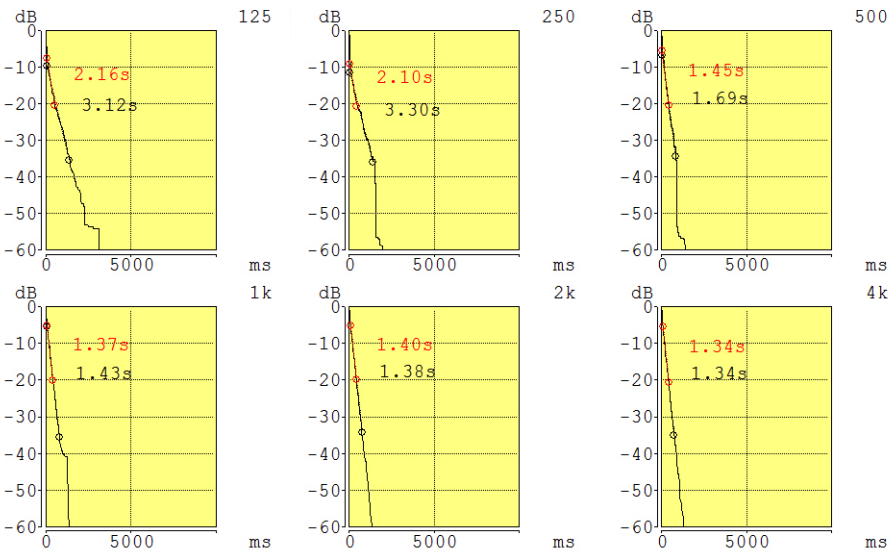

Concrete
(flat)

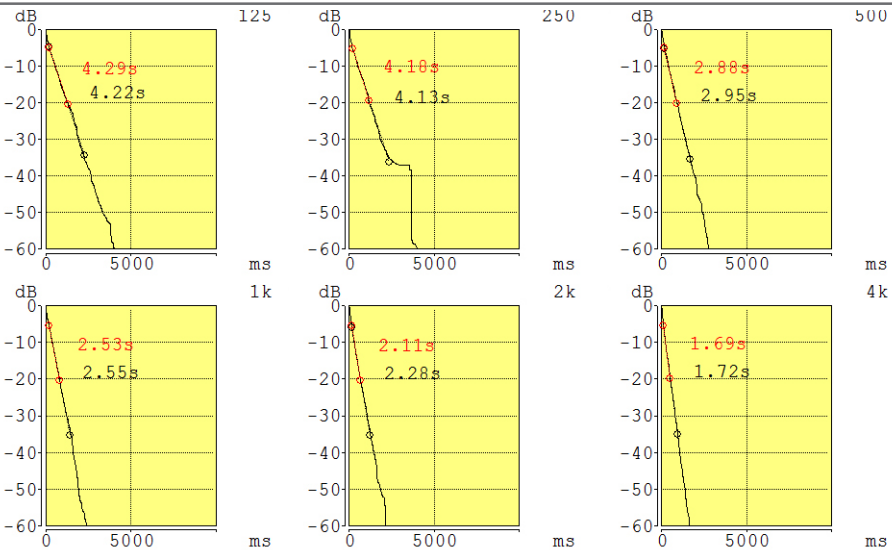

Concrete
(coupled volume)

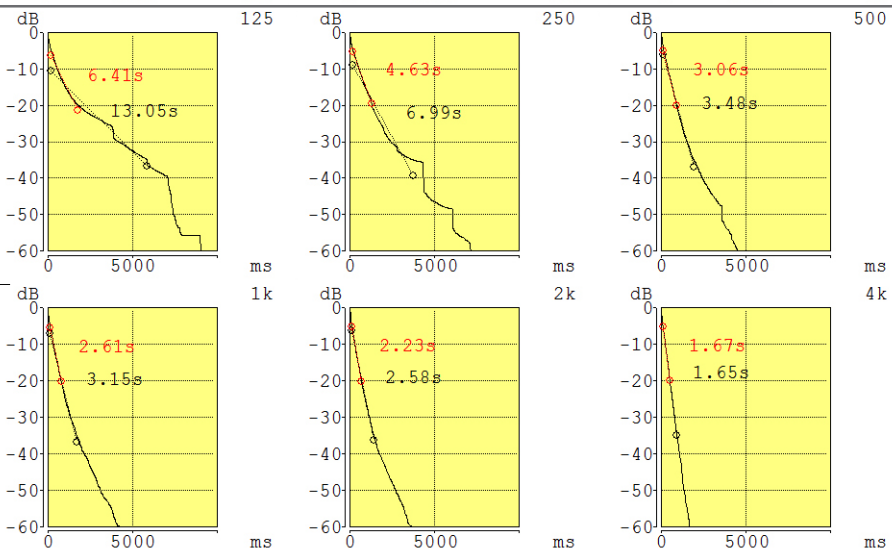

Just like in the case of walls, the absorptive ceiling does more harm than good, while the concrete ceiling reflects low frequency sound back into the concert hall.

However, the more intricate part of the analysis is the difference in the acoustics of the space when integrating building systems in design and analyzing their effect on interaction of sound with the hall instead of a flat concrete ceiling. Concrete is still the material used but with various building systems integrated together in the design of the ceiling and overall design of the hall.

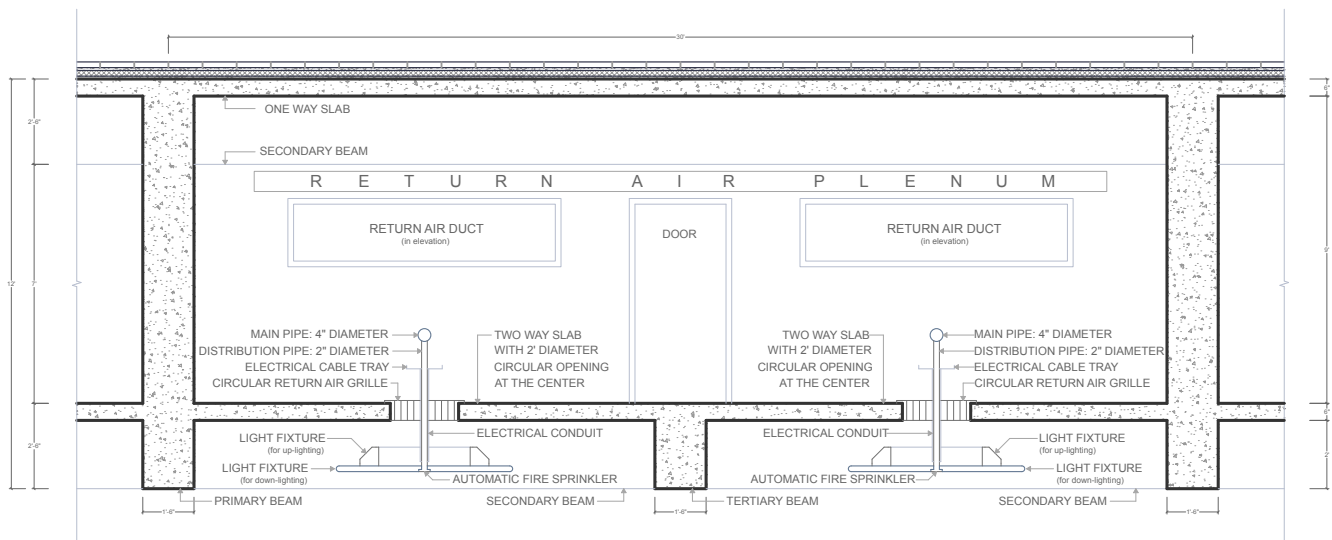

INTEGRATED BUILDING SYSTEMS: CEILING MODULE

With the integrated building systems, sound gets into the return air plenum and takes time to come back into the hall, thereby increasing the reverberation time. This changes the manner in which the sound decays: the line curves as shown in the previous page, resulting in a reverberant and lively space: more towards the low frequency octave bands and lesser towards the high frequency octave bands, which is the necessary manner of decay in a concert hall for symphony orchestra and choir for the reason of achieving sufficient bass ratio. At the same time, clarity is preserved.

The ceiling, with its integrated building systems, has been designed to enhance the acoustics of the hall, while complementing views outside, especially that of the sky...

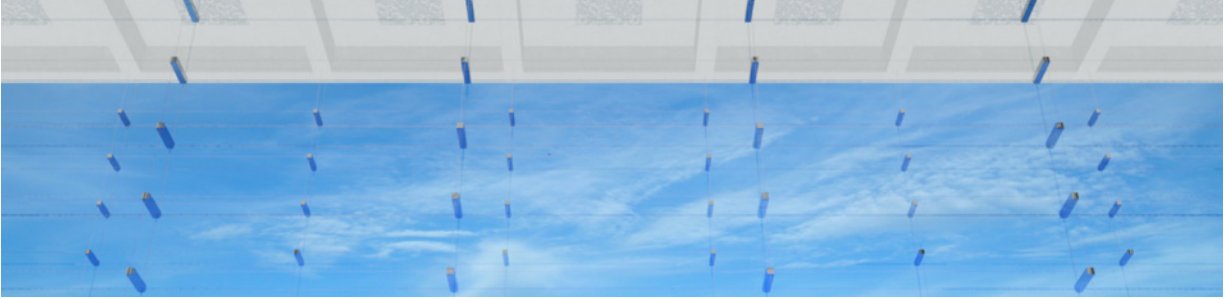

THE CEILING

The Design



Illustration 4

SITE PLAN



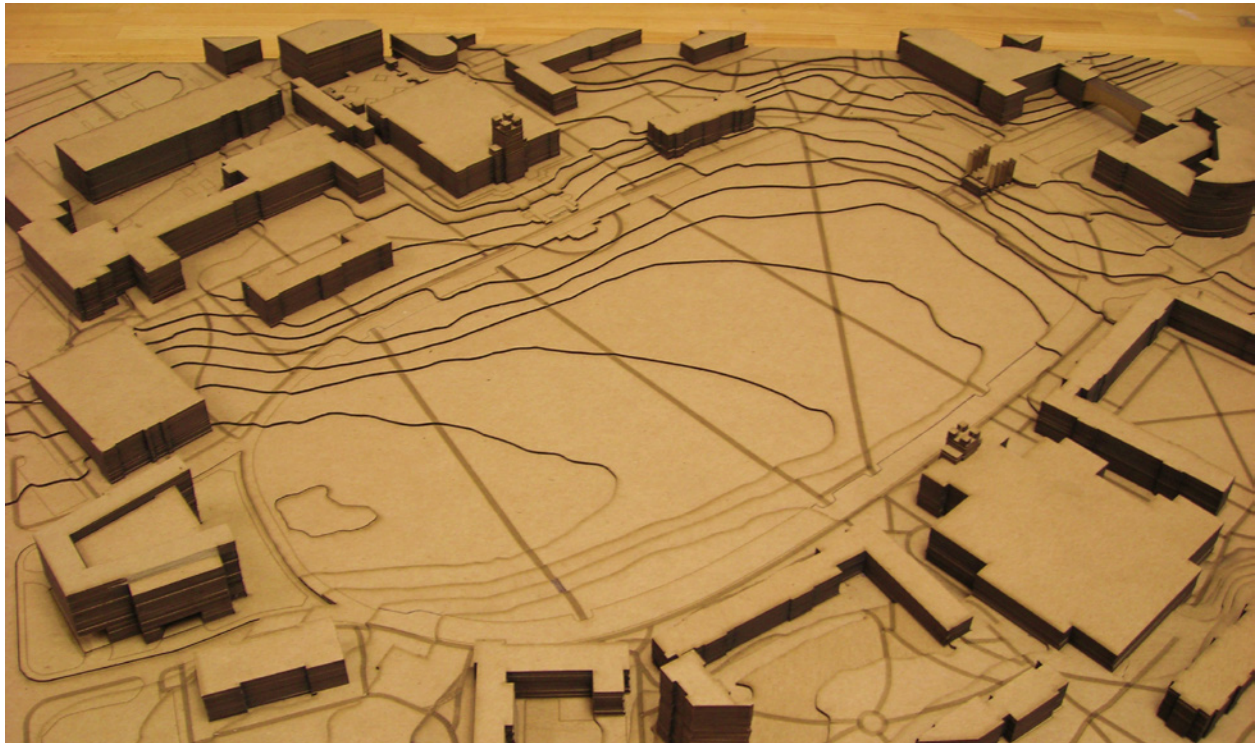

SITE MODEL

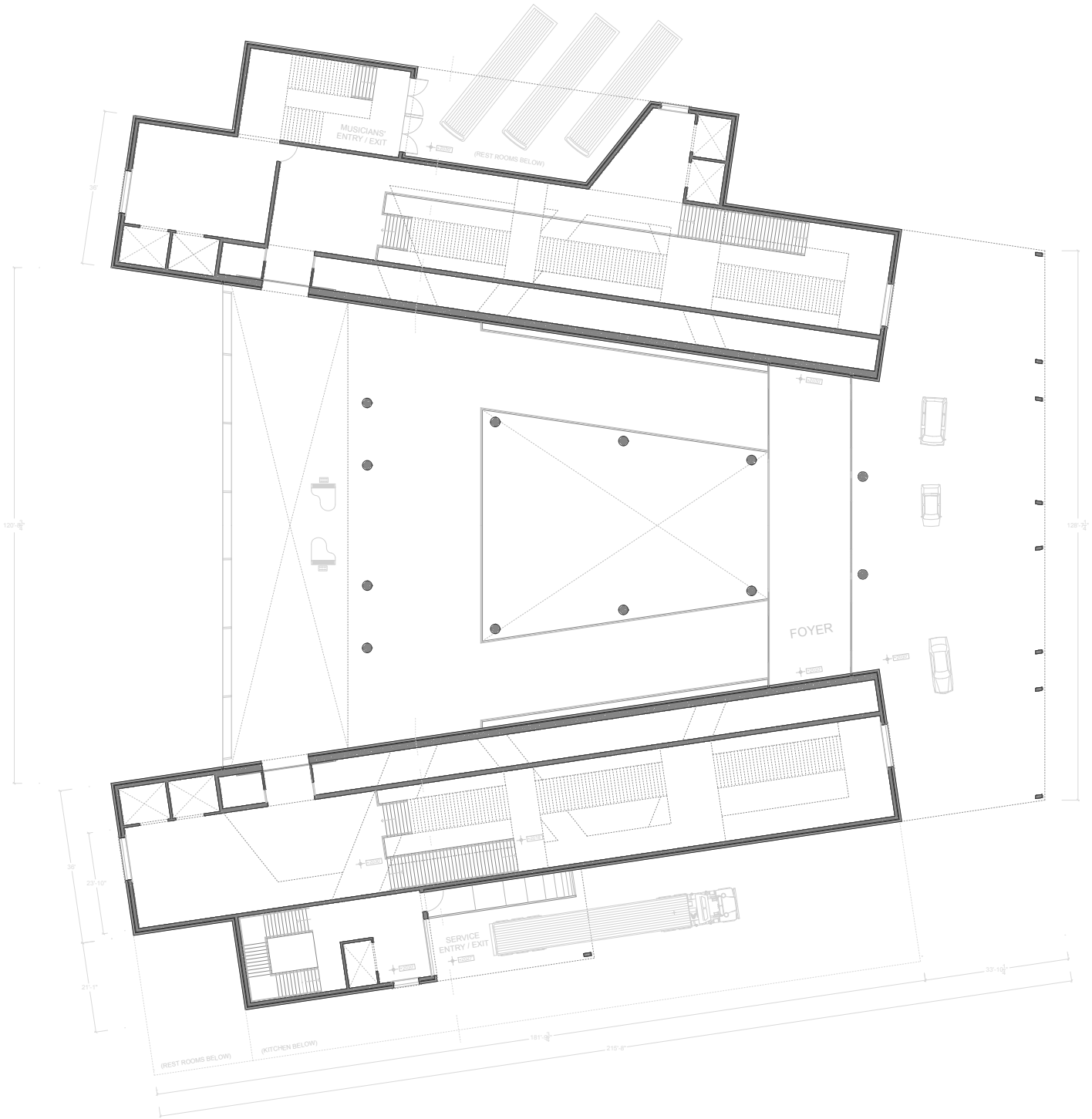

SCALE:
 0' 10' 20' 30' 50'

FIRST FLOOR PLAN



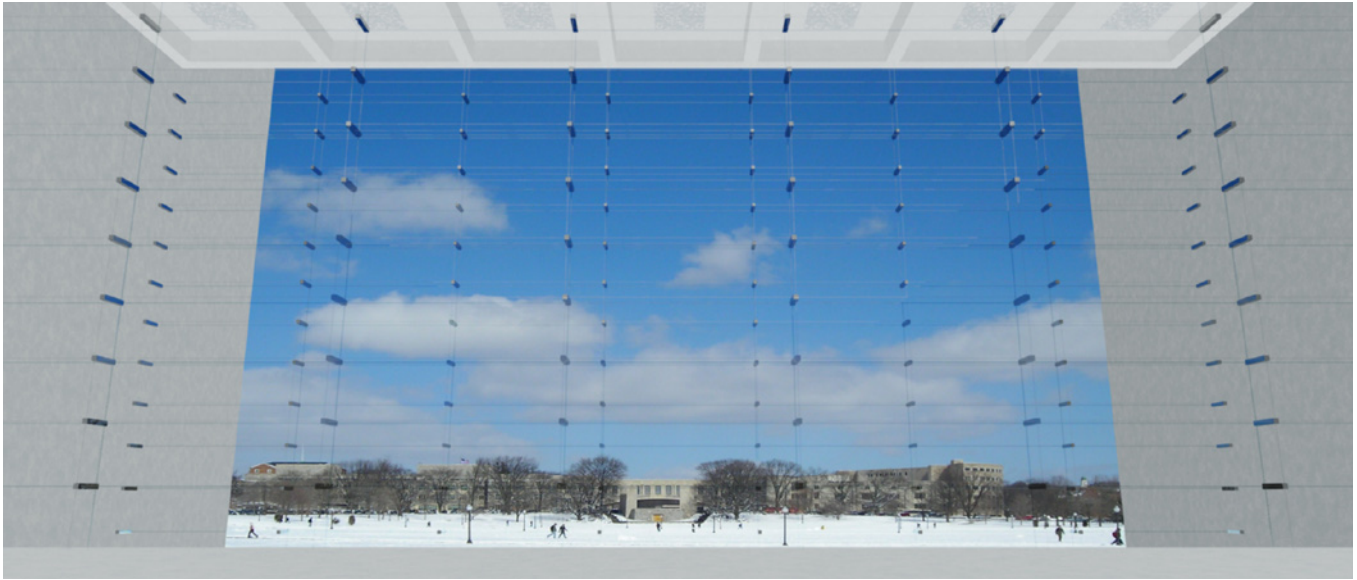

CONCERT HALL: ADAPTED VIEW

Note: This is an adapted view from the concert hall: the image used as background was captured at 6 feet above ground level; the magnificence of the actual view at over 24 feet above ground level would be much greater, as explained through another adapted view in the 'Postlude', in page 77.

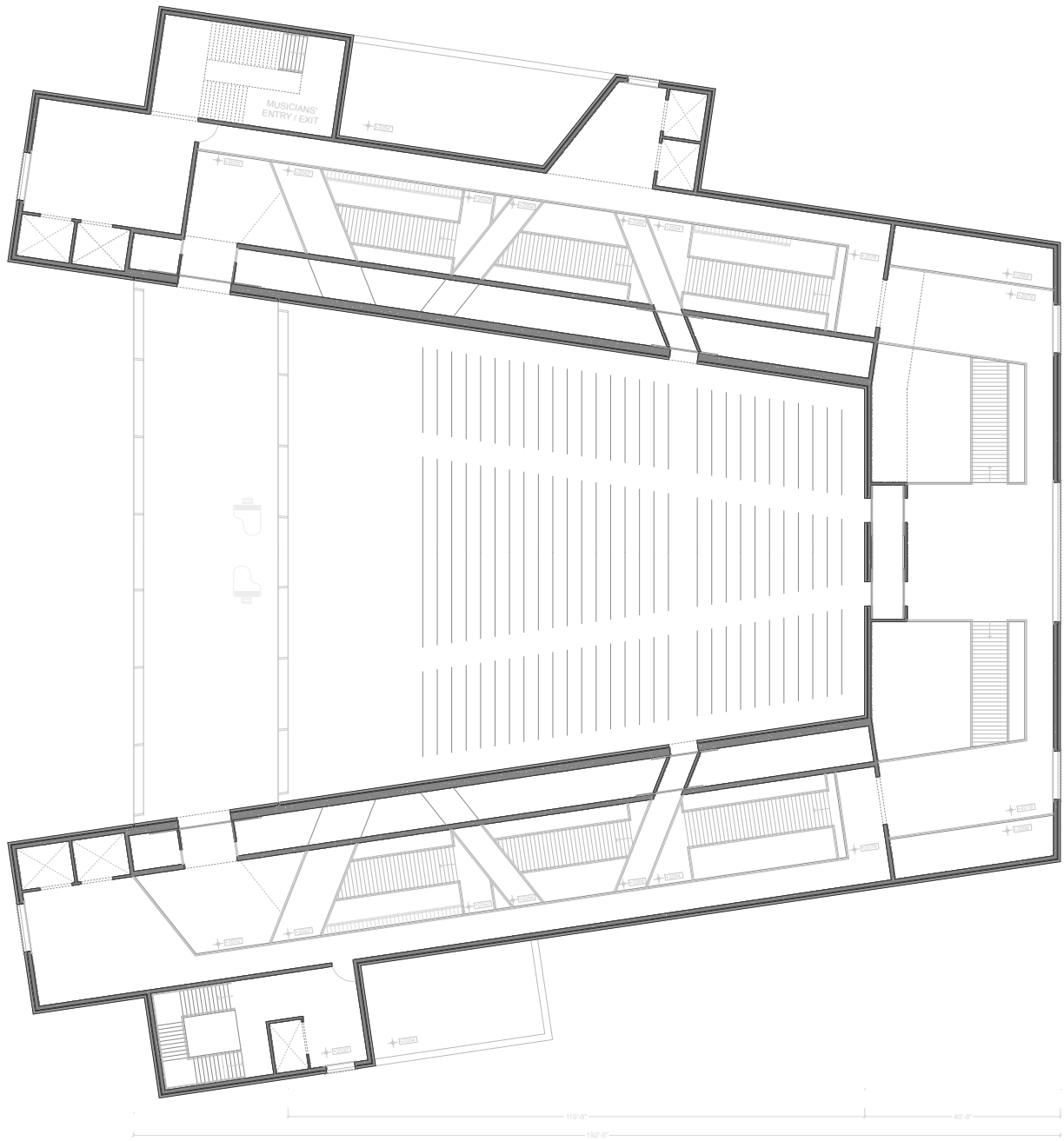

SCALE:
 0' 10' 20' 30' 50'

FIFTH FLOOR PLAN





CONCERT HALL: ADAPTED VIEW

Note: This is an adapted view from the concert hall: the image used as background was captured at 6 feet above ground level; the magnificence of the actual view at over 24 feet above ground level would be much greater, as explained through another adapted view in the 'Postlude', in page 77.

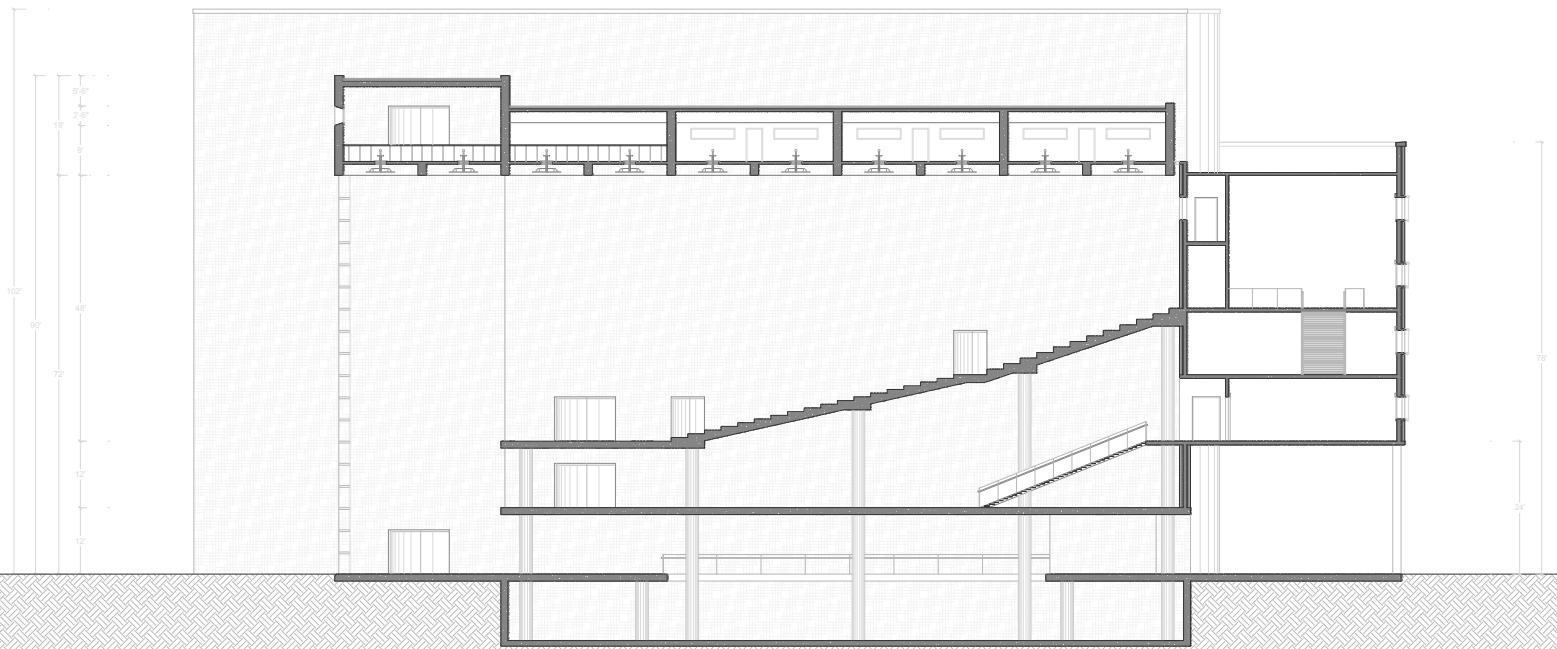

SECTION THROUGH CENTER OF CONCERT HALL

SCALE:





LOBBY: AUTUMN

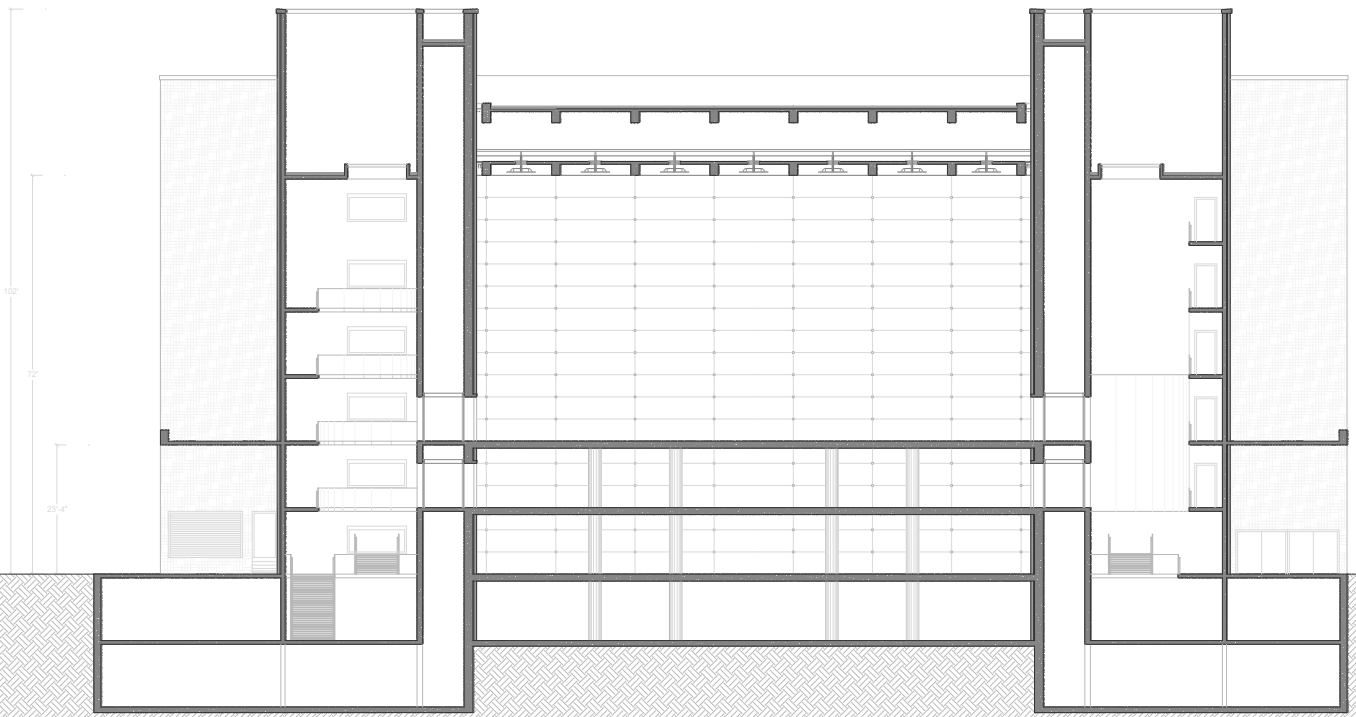

ADAPTED SECTION THROUGH STAGE AND WINGS

SCALE:



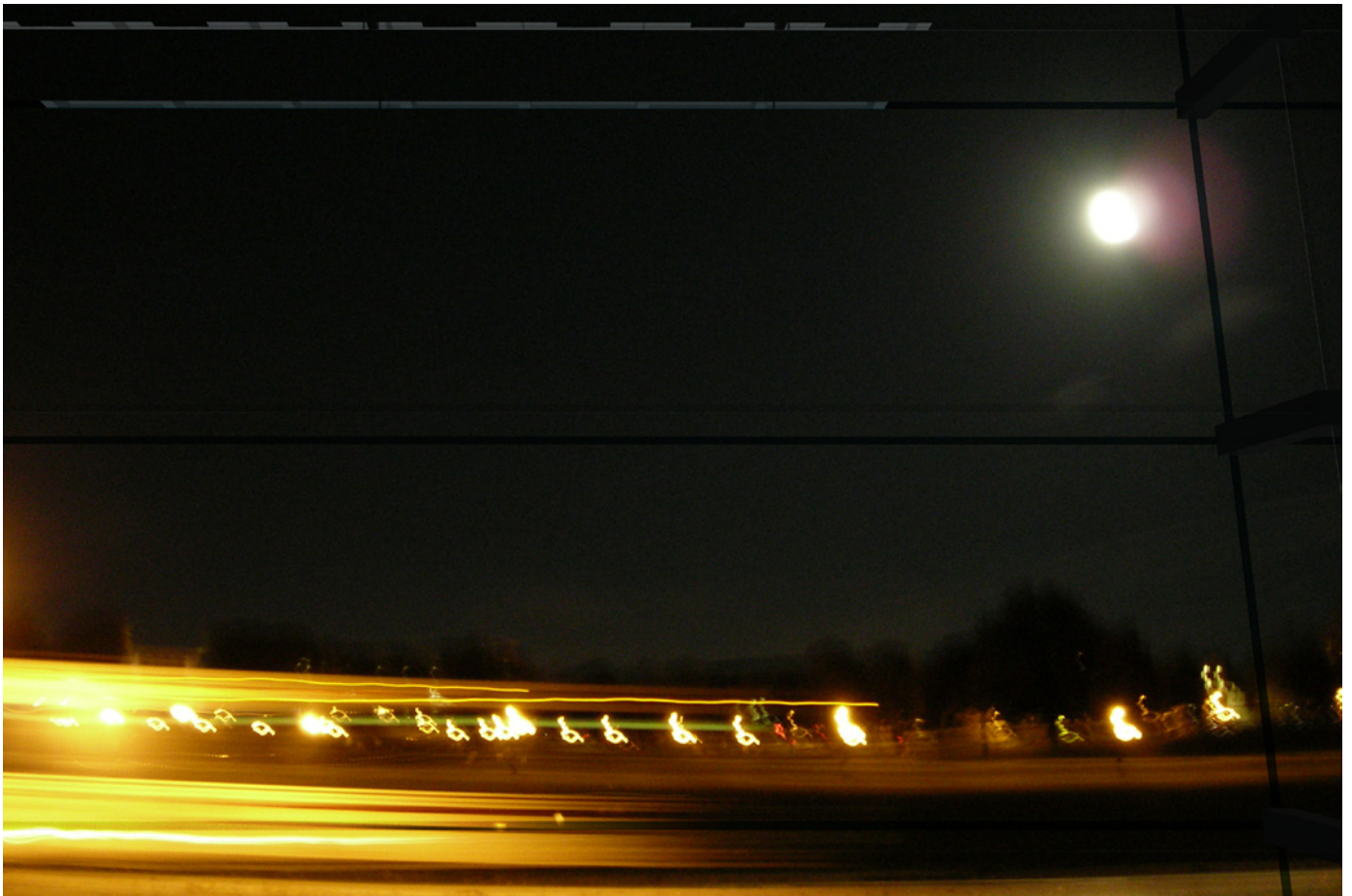

LOBBY: NIGHT

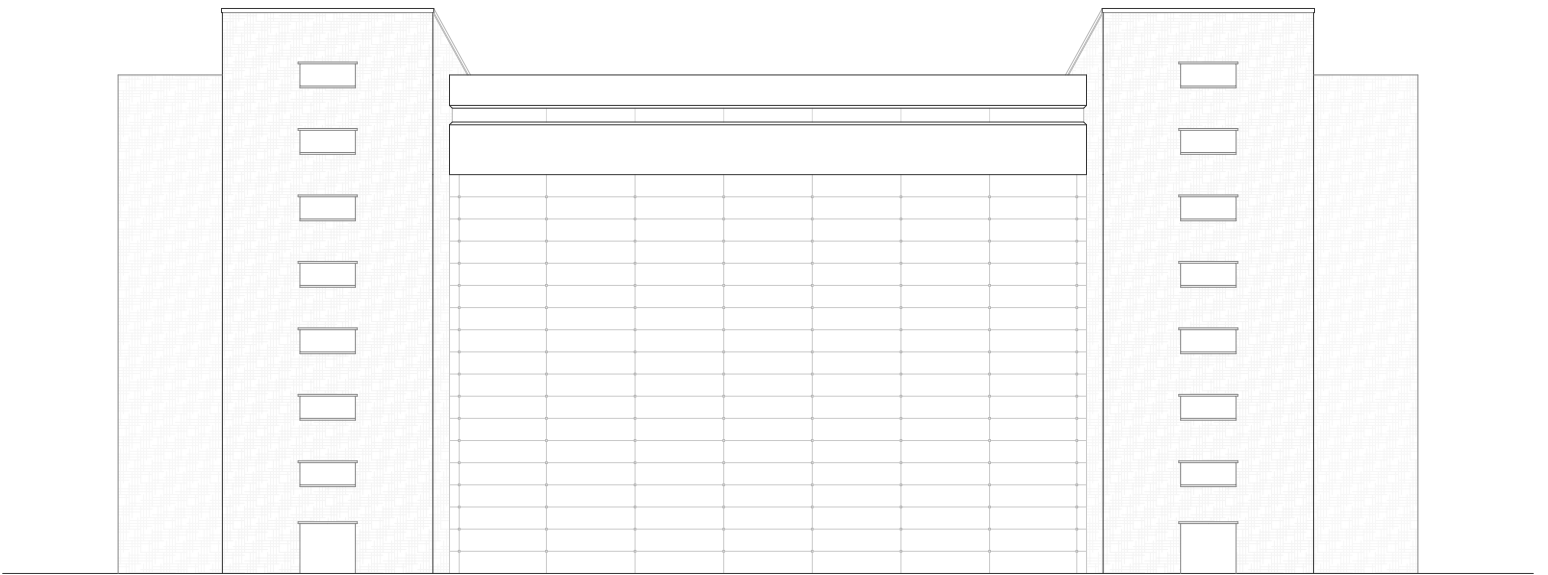

ELEVATIONAL PERSPECTIVE

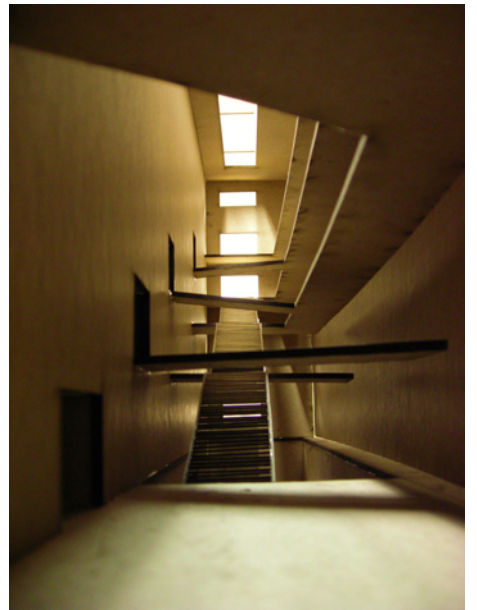

NORTH WING: INTERIOR

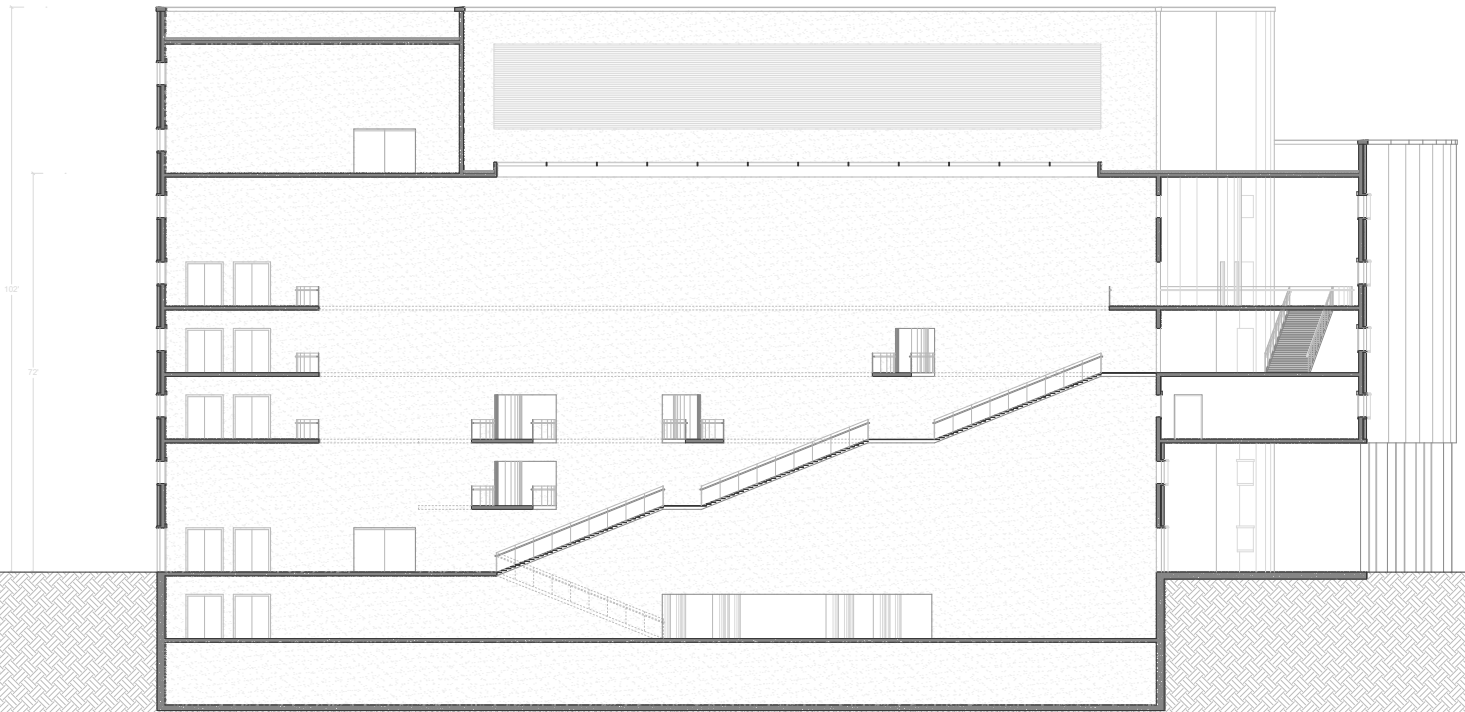

SECTION THROUGH CENTER OF NORTH WING

SCALE:



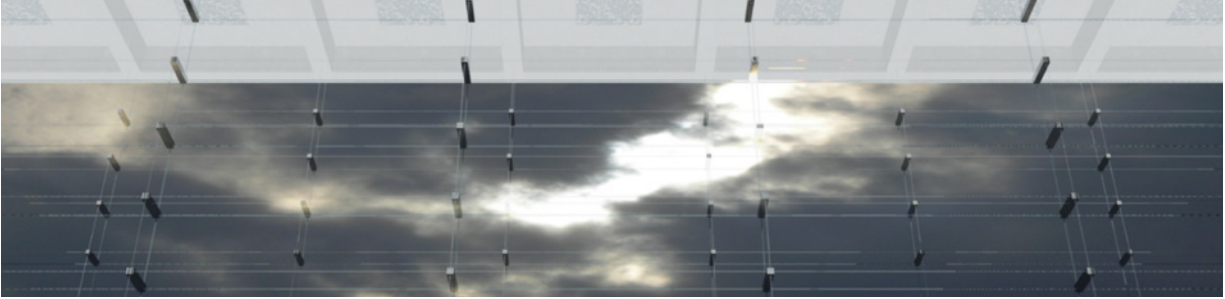

THE CEILING

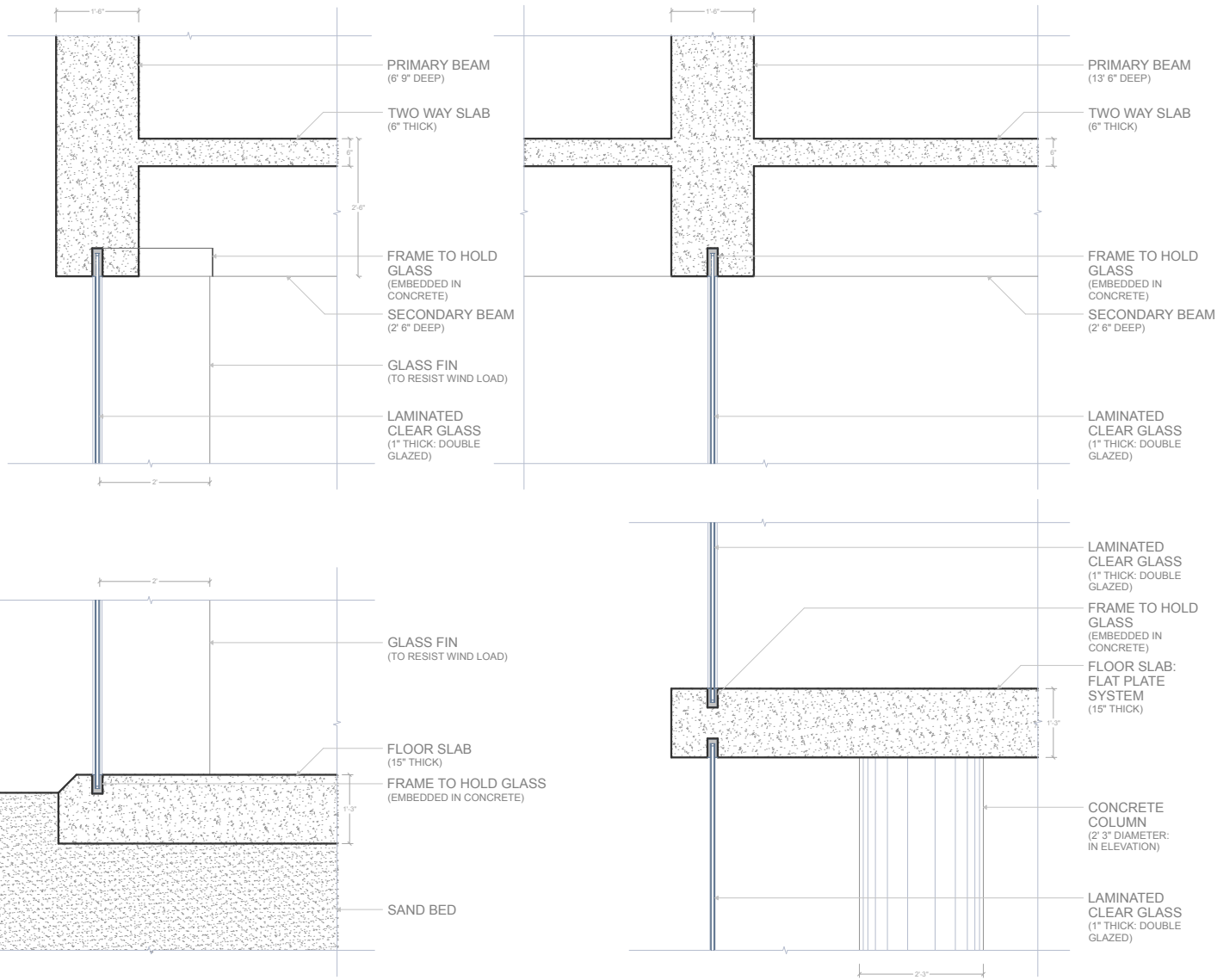

GLASS - CONCRETE CONNECTIONS
(SECTION)

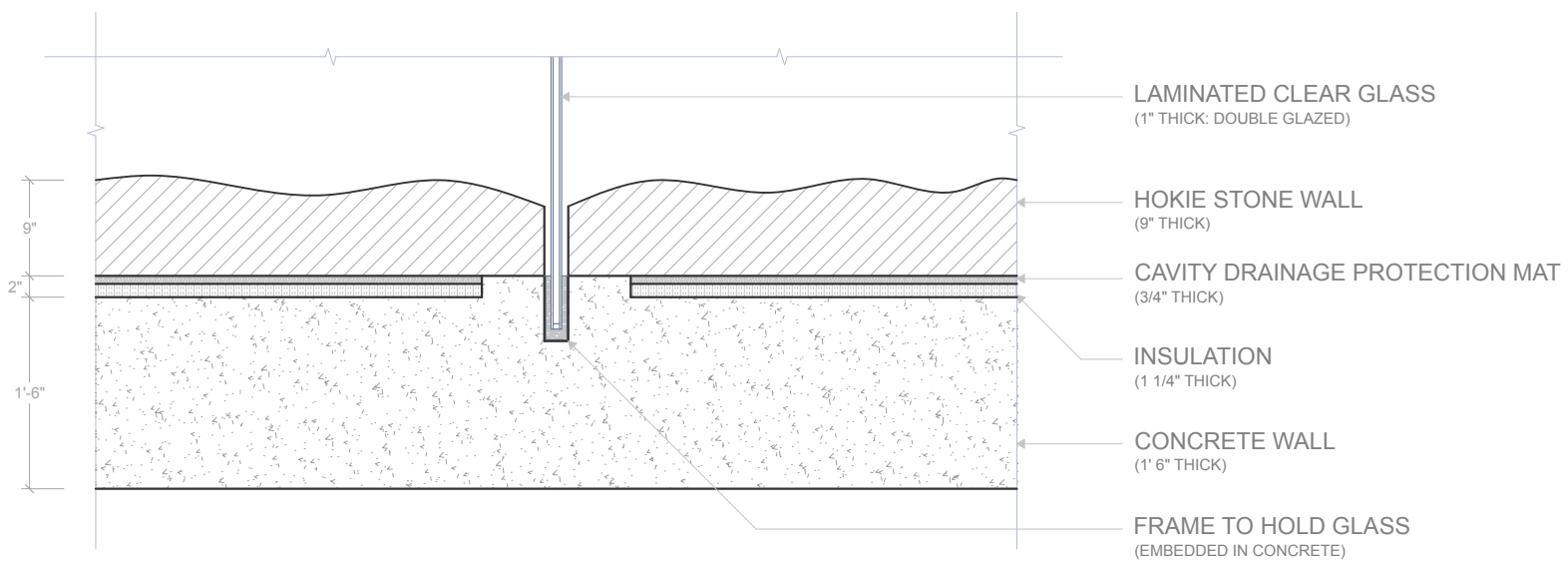

WALL - GLASS CONNECTION
 (PLAN)

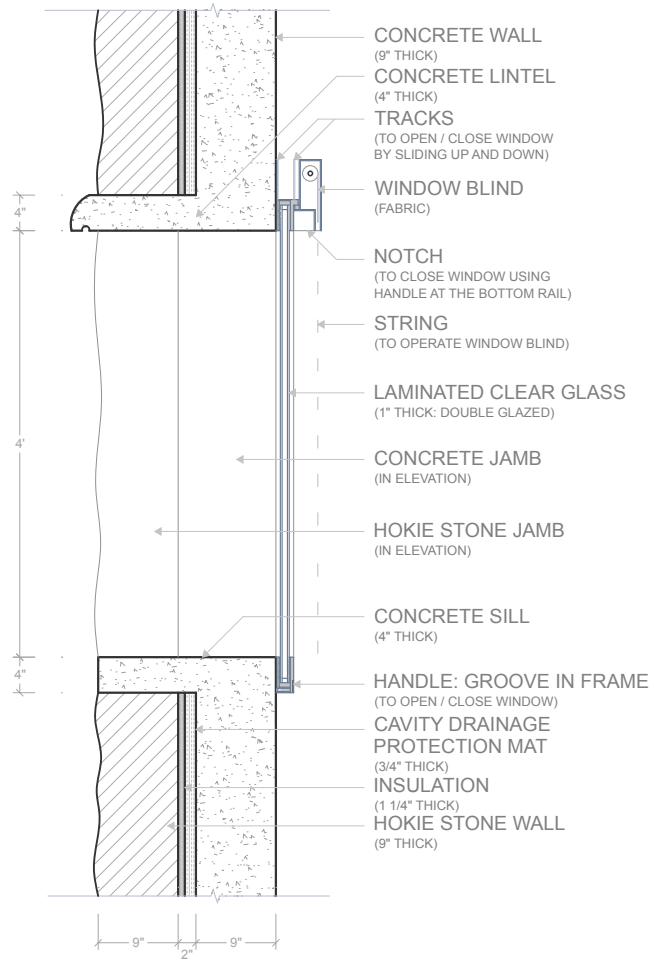

(SECTION)

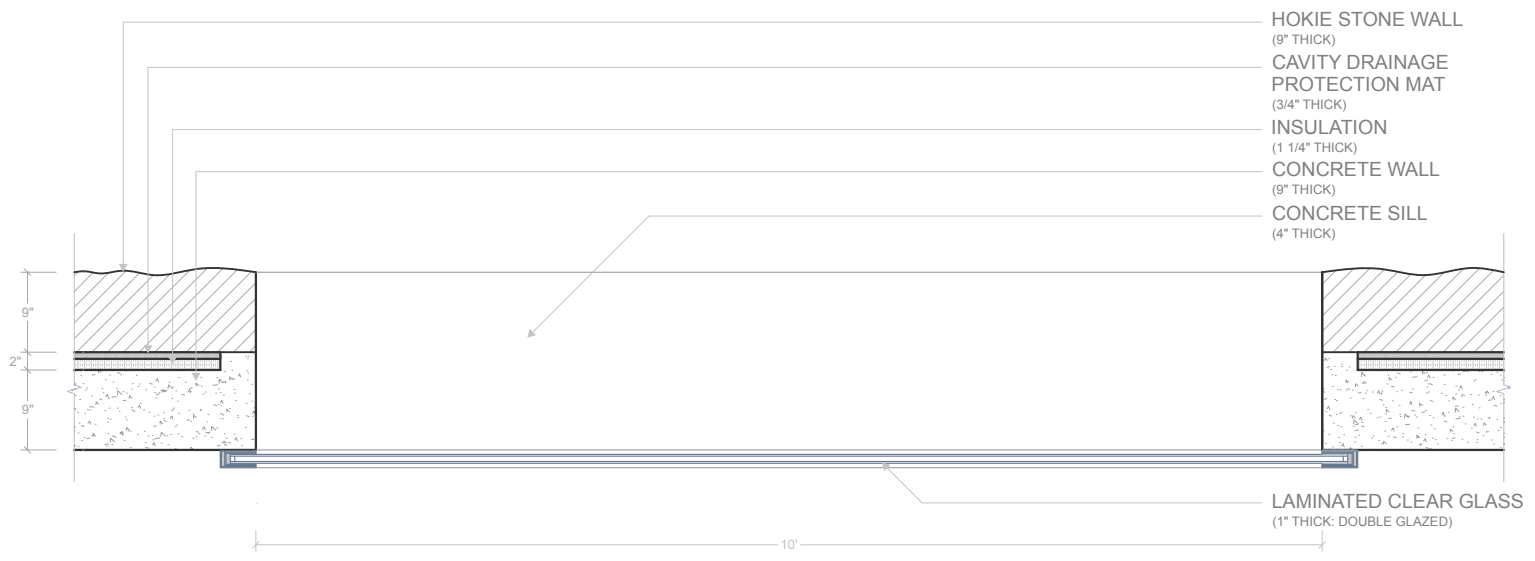

(PLAN)

WINDOW



THE CONCERT HALL WITH ITS 'HOKIE STONE' WALLS LIT FROM ABOVE

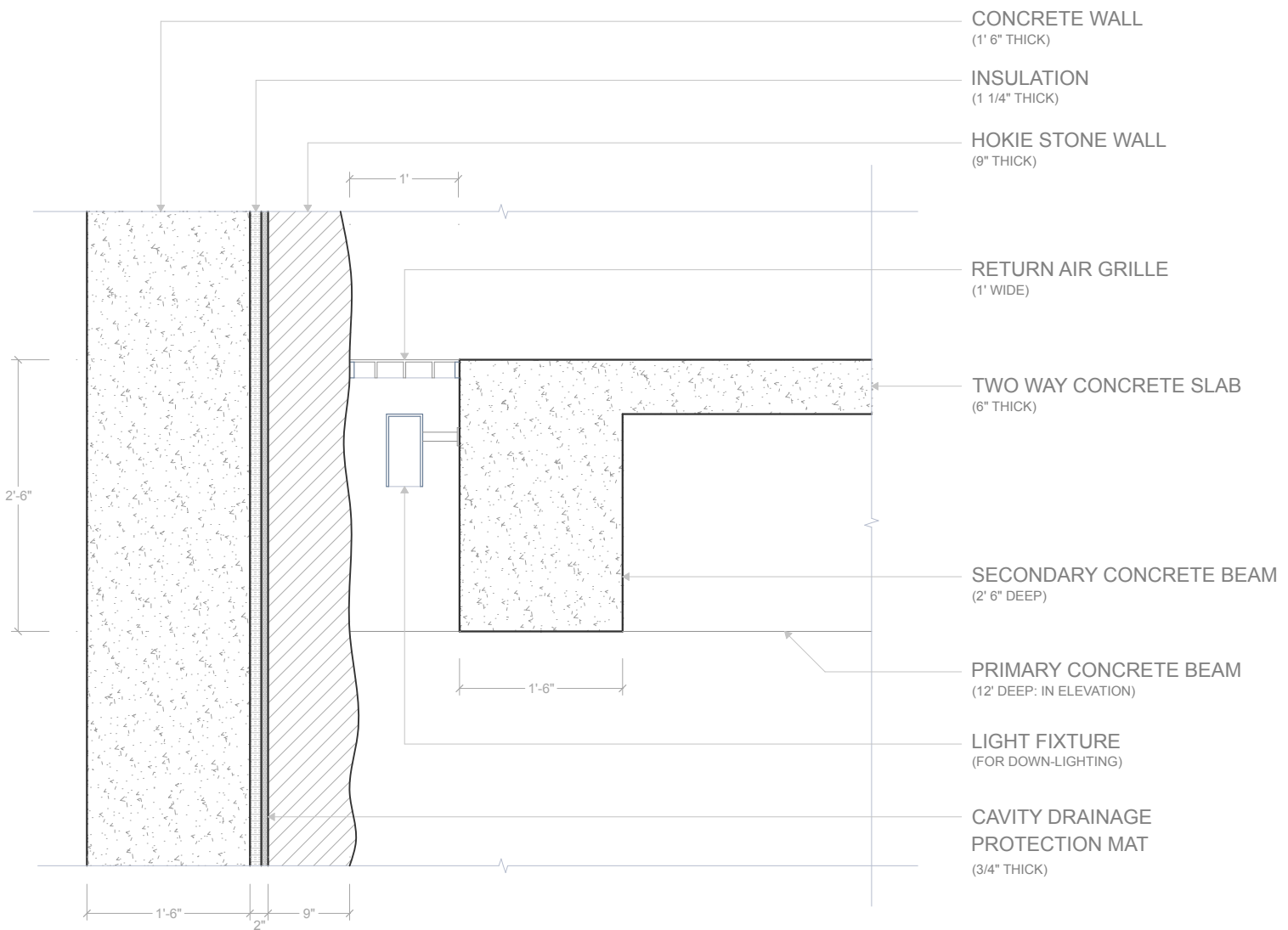

WALL - CEILING CONNECTION
 (SECTION)

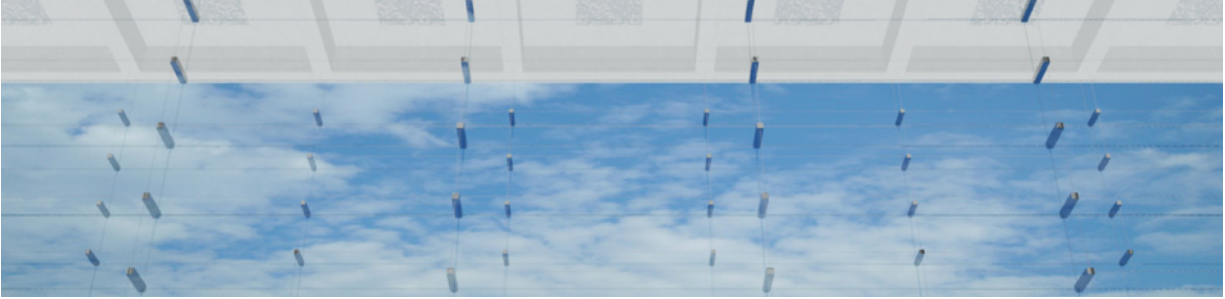

THE CEILING

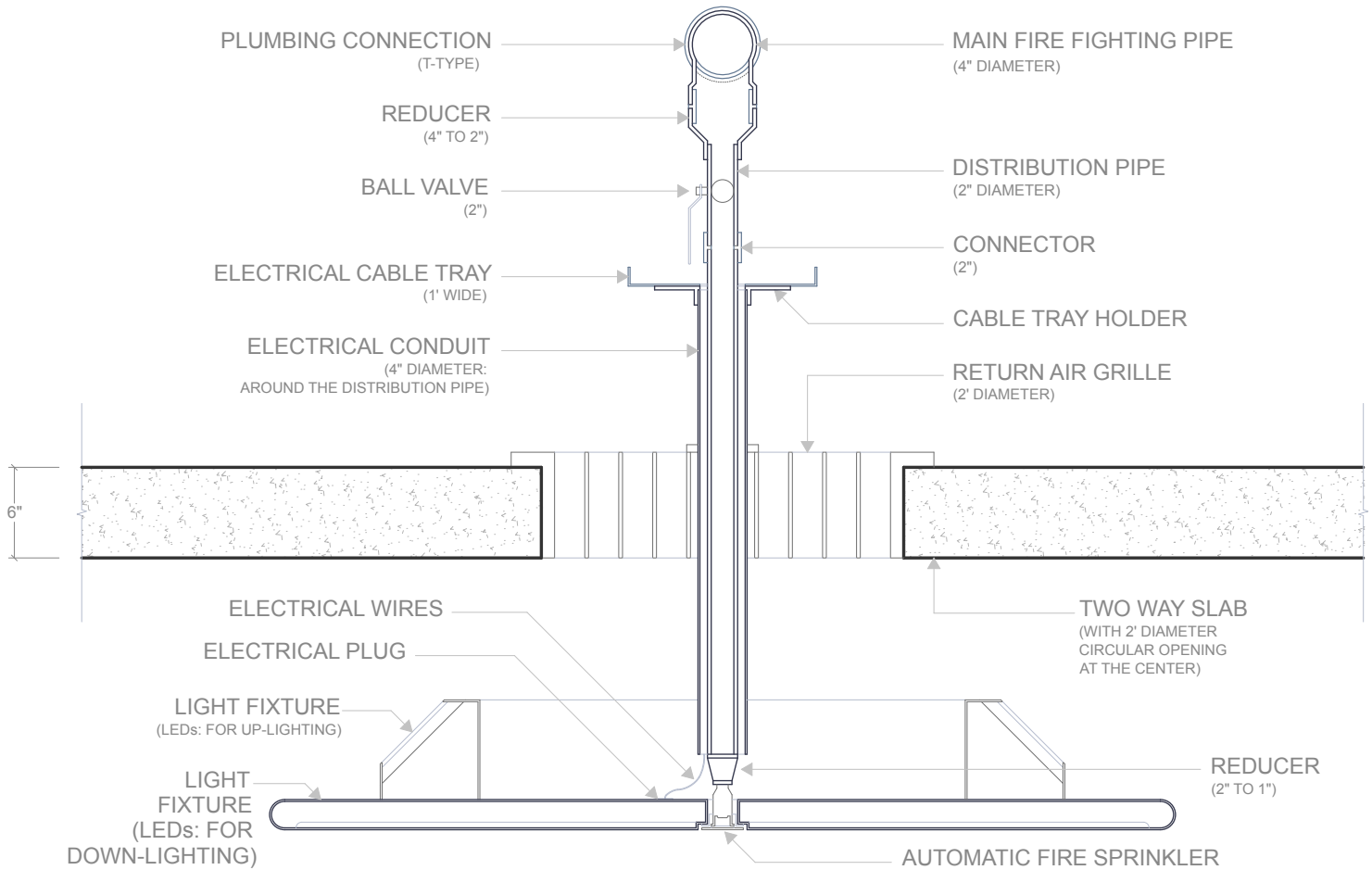

THE INSTALLATION

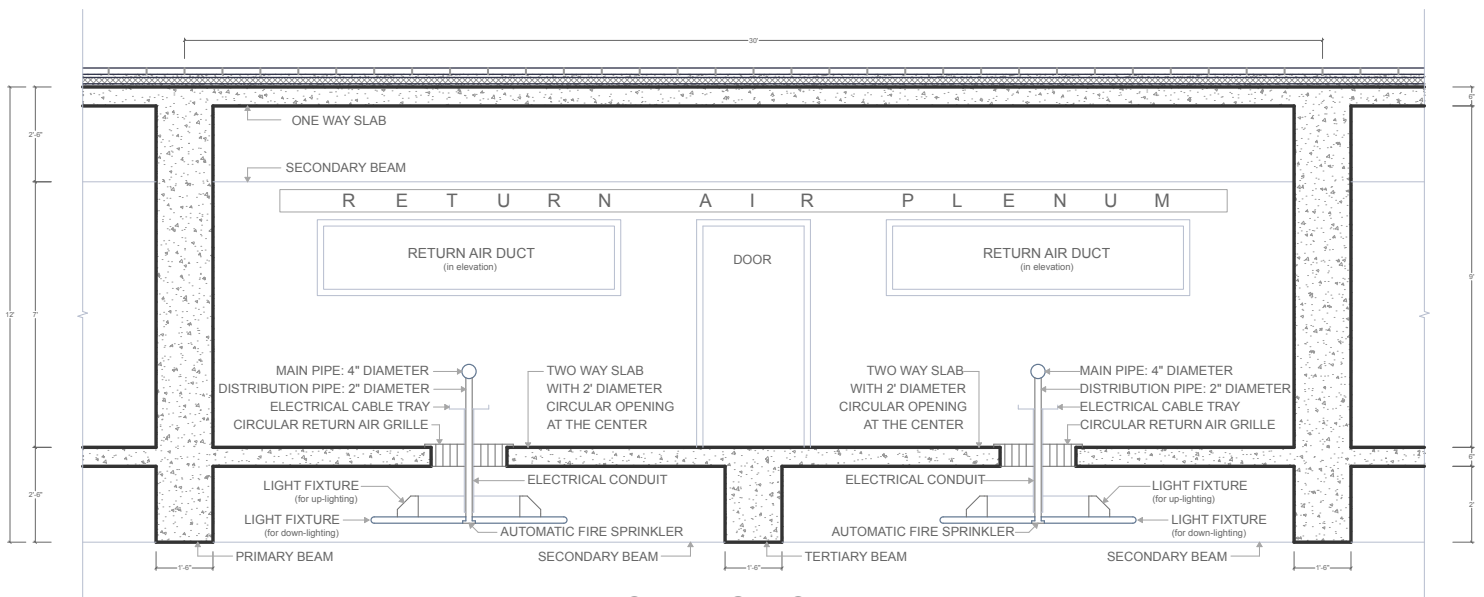

CEILING MODULE

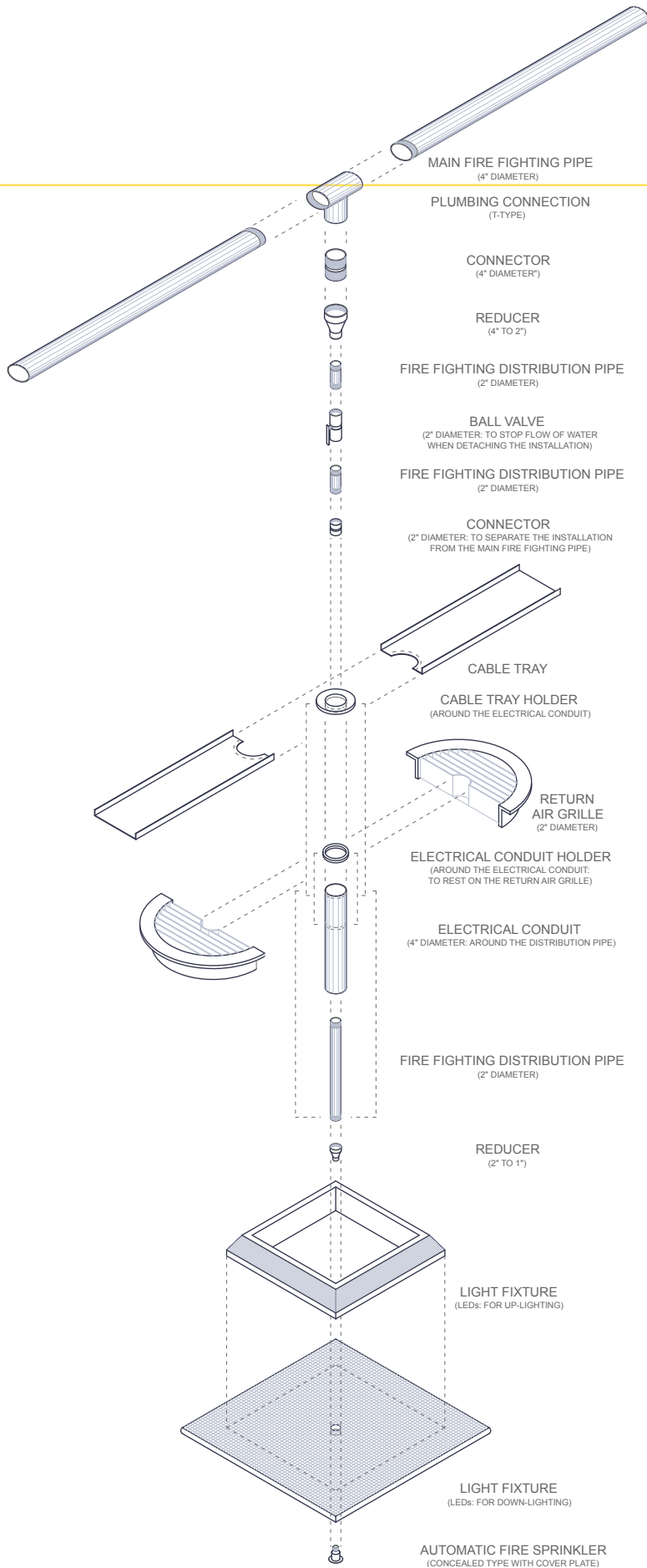

Postlude



Illustration 5

CONCERT HALL: ADAPTED VIEW

The concert hall is an environment that responds to seasons, weather changes, memorials that are by the site and much more - the moon, the stars, the clouds, activities in the drillfield... and the list goes on. It is a place to contemplate, while listening to the music performed...

“Joyful, joyful, we adore Thee, God of glory, Lord of love;
Hearts unfold like flowers before Thee, opening to the sun above.
Melt the clouds of sin and sadness; drive the dark of doubt away;
Giver of immortal gladness, fill us with the light of day!

“All Thy works with joy surround Thee, earth and heaven reflect Thy rays,
Stars and angels sing around Thee, center of unbroken praise.
Field and forest, vale and mountain, flowery meadow, flashing sea,
Singing bird and flowing fountain call us to rejoice in Thee.

“Thou art giving and forgiving, ever blessing, ever blessed,
Wellspring of the joy of living, ocean depth of happy rest!
Thou our Father, Christ our Brother, all who live in love are Thine;
Teach us how to love each other, lift us to the joy divine.

“Mortals, join the happy chorus, which the morning stars began;
Father love is reigning o’er us, brother [and sister] love binds man to man [person to person].
Ever singing, march we onward, victors in the midst of strife,
Joyful music leads us [to God] in the triumph song of life.”³⁰

The design of the concert hall for symphony orchestra and choir with variations...

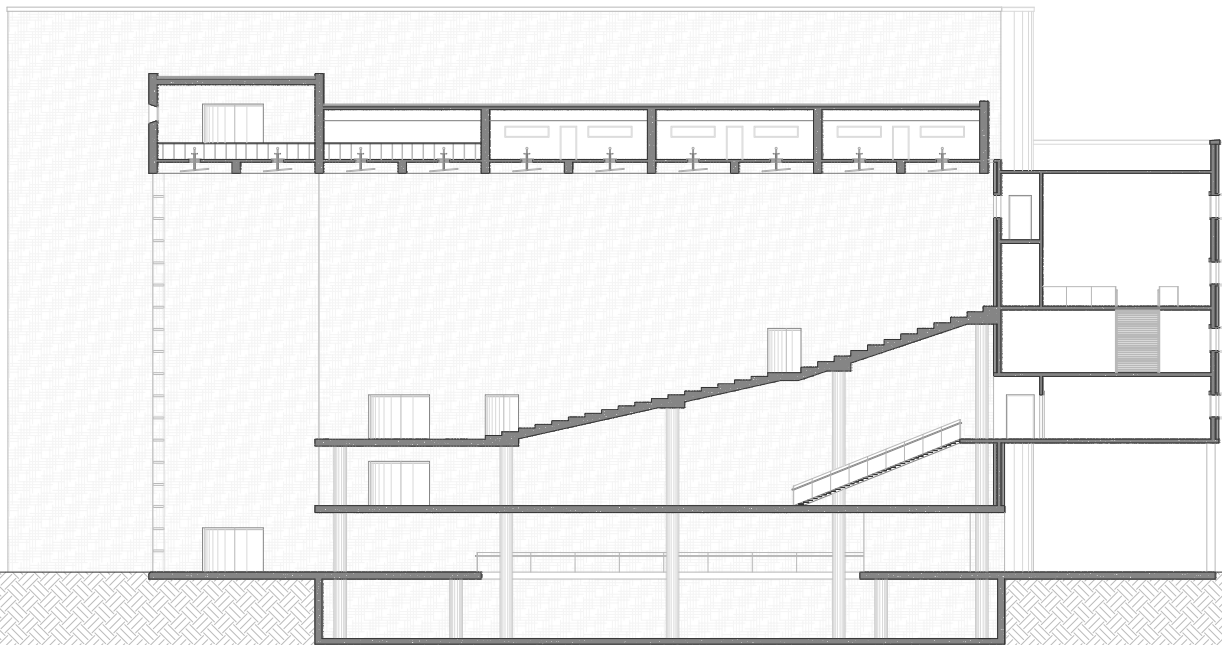

VARIATION 1: DIRECTIONAL LIGHTING

If the light fixtures are at an angle as shown in the drawing above, concert lighting becomes directional: the up-lights would light the beams and slabs more towards one side and lesser towards the other side.

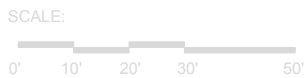

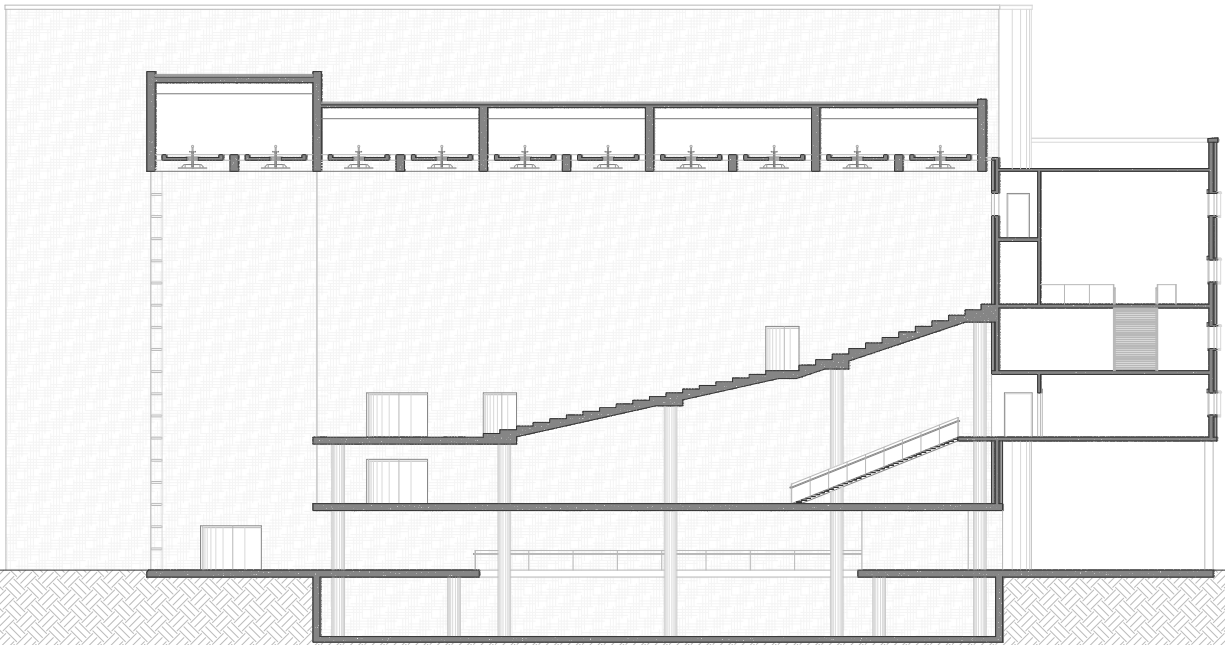

VARIATION 2: DETACHED CEILING SLABS

Detaching the ceiling slabs as shown, allows the ceiling 'and' roof slabs to be seen from the concert hall.



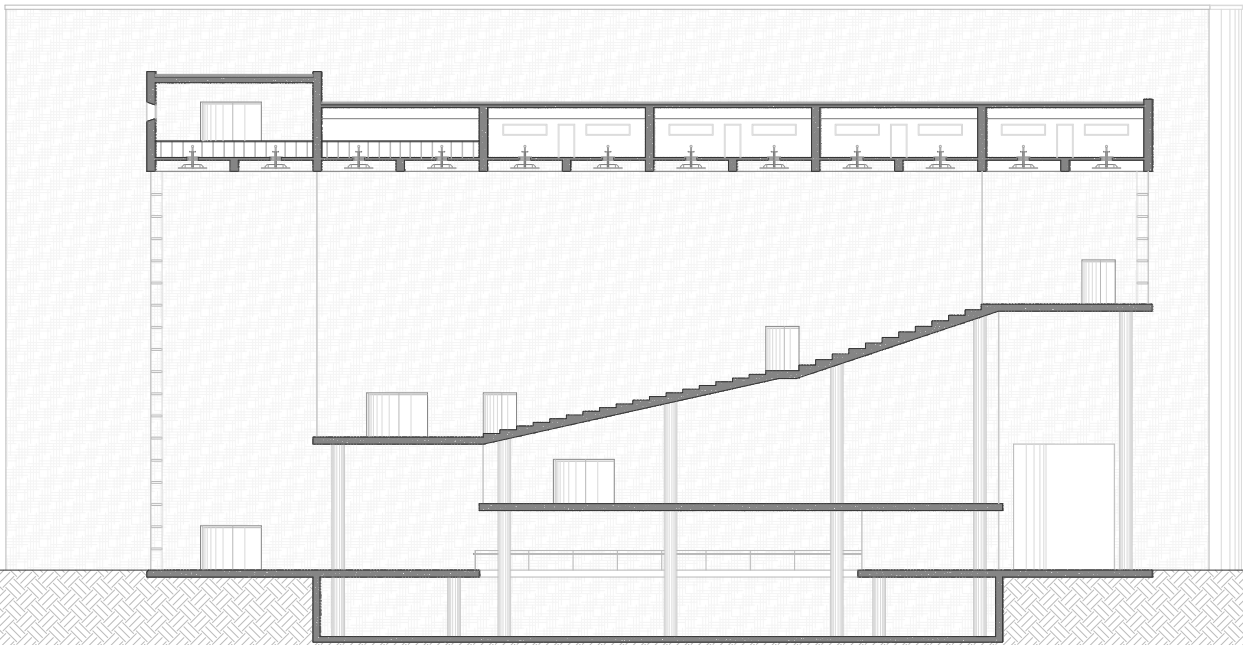

VARIATION 3: GLASS: TWO SIDES

In this variation, the space flows in two directions as a result of using glass for two sides of the facility.

SCALE:



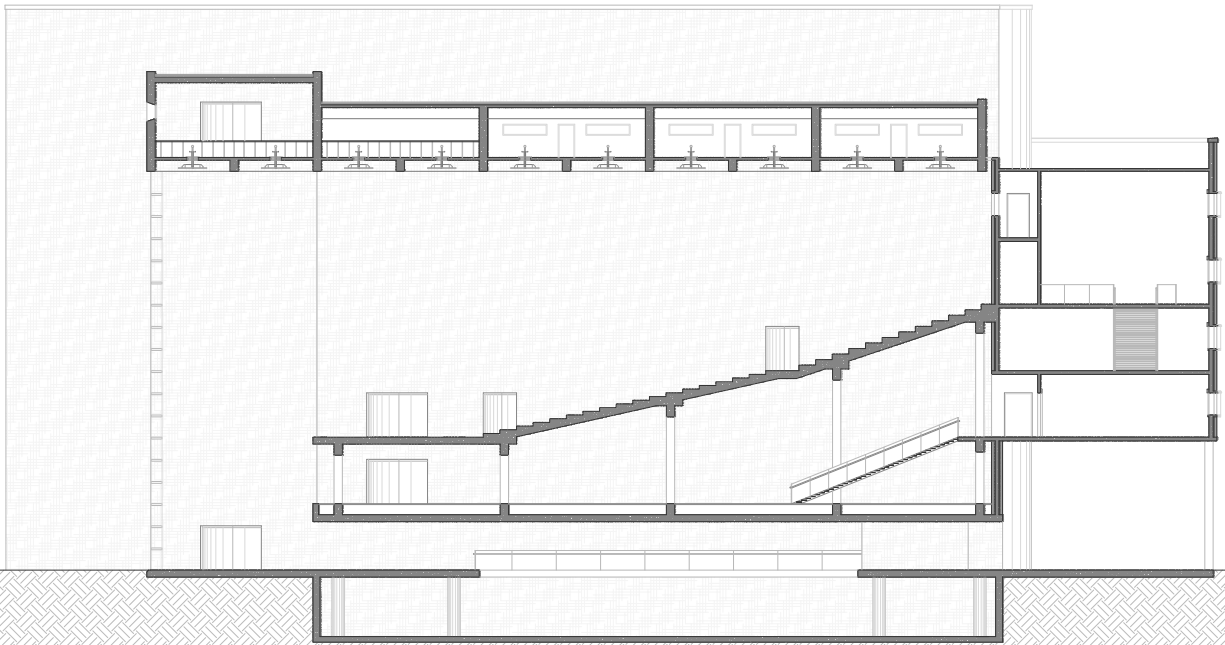

VARIATION 4: COLUMN-FREE ENTRY

The use of viereindeel beams to support slabs, as shown in the drawing, results in a column-free entry.



The concert hall could become a 'stage for the drillfield' if the glass walls slide down. Two elevators on either side of the glass walls, (in plan), designed to work in coordination with each other, slide the deep frame, (concealed within the concrete beam), from which the entire glass curtain wall system hangs. The stage floor is a platform that could be raised or lowered. The audience space becomes seating for the choir. This variation is most appropriate to the context since the facility serves for outdoor performances, in addition to providing a spectacular environment for indoor concerts, while meticulously handling lower reflectivity and lower transmission loss values of glass for lower frequencies of sound, and strategically using the same in conjunction with other building materials!

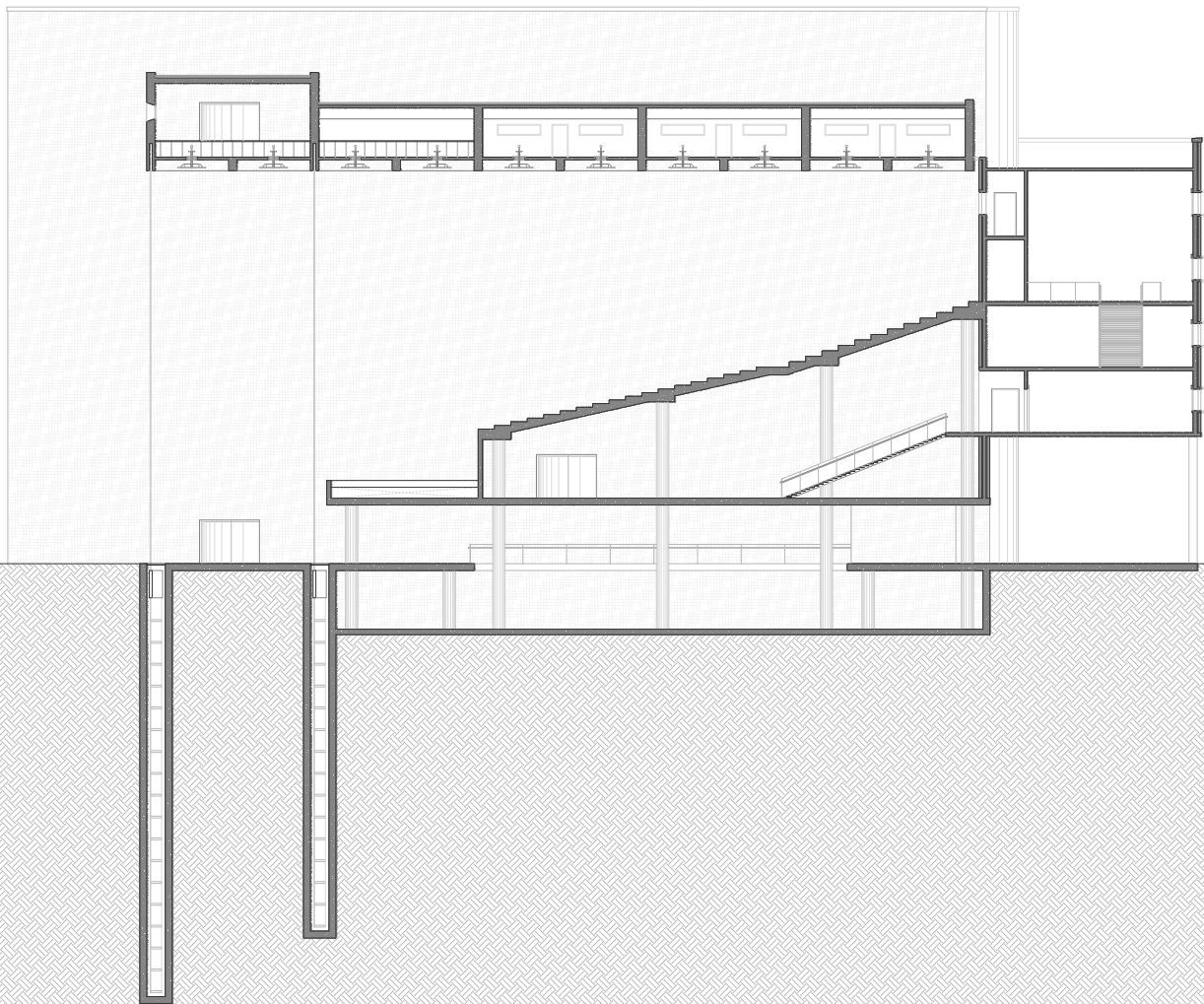

SCALE:
0' 10' 20' 30' 50'

VARIATION 5: CONCERT HALL AS
'STAGE FOR THE DRILLFIELD'

The concert hall allows people to look through the walls of glass and get connected to the world outside: reminding the 'past' through the backdrop of memorials, the 'present' beauty of the vast green ground, and the blue sky that represents the 'future' sustained by faith and hope. The concert hall thus triggers the senses of perception enabling people to recall happenings of the past, to appreciate the changing seasons of the year and to expect a bright morrow. The glass that physically separates the concert hall from the surroundings, actually connects the people inside to the outside. The concert hall keeps people 'tuned' to nature through the music with a holistic combination of sound and space, while being a 'stage' to the drillfield for various outdoor activities and functions that happen throughout the year!



CONCERT HALL FOR SYMPHONY ORCHESTRA AND CHOIR

References

1. Leo Beranek, Concert and Opera Halls: How they sound, Acoustical Society of America, 1996, p181
2. Author's statement
3. Leo Beranek, Concert and Opera Halls: How they sound, Acoustical Society of America, 1996, p181
4. Leo Beranek, Concert and Opera Halls: How they sound, Acoustical Society of America, 1996, p181
5. Leo Beranek, Concert and Opera Halls: How they sound, Acoustical Society of America, 1996, p181
6. Leo Beranek, Concert and Opera Halls: How they sound, Acoustical Society of America, 1996, p181
7. Leo Beranek, Concert and Opera Halls: How they sound, Acoustical Society of America, 1996, p79
8. Leo Beranek, Concert and Opera Halls: How they sound, Acoustical Society of America, 1996, p79
9. Leo Beranek, Concert and Opera Halls: How they sound, Acoustical Society of America, 1996, p79
10. Leo Beranek, Concert and Opera Halls: How they sound, Acoustical Society of America, 1996, p79
11. Leo Beranek, Concert and Opera Halls: How they sound, Acoustical Society of America, 1996, p79
12. Leo Beranek, Concert and Opera Halls: How they sound, Acoustical Society of America, 1996, p79
13. Leo Beranek, Concert and Opera Halls: How they sound, Acoustical Society of America, 1996, p377
14. Leo Beranek, Concert and Opera Halls: How they sound, Acoustical Society of America, 1996, p377
15. Leo Beranek, Concert and Opera Halls: How they sound, Acoustical Society of America, 1996, p377
16. Leo Beranek, Concert and Opera Halls: How they sound, Acoustical Society of America, 1996, p377
17. In Casa da Musica, in Porto, Portugal, the walls at either end of the hall are made of enormous sheets of corrugated glass suggesting the folds of a curtain, giving a distorted view of the city.
http://www.nytimes.com/2005/04/10/arts/design/10ouro.html?pagewanted=2&_r=2 (Jan 7th, 2009)
18. Harmony Hall, in Kansai, Japan, uses glass extensively for all walls: however, it is a small hall, with 446 seats and not designed accommodate a full symphony orchestra of about a hundred instruments.
<http://www.nagata.co.jp/sakuhin/factsheets/nara.pdf>
19. Esther Eastman Center, in Lakeville, USA, has glass for the side walls and rear wall to offer views of the lake outside and allow people walking by the structure, to see in, making the music accessible, and hopefully, attractive to all.
http://livedesignonline.com/mag/class_glass/ (Jan 7th, 2009)
20. http://www.nytimes.com/2005/04/10/arts/design/10ouro.html?pagewanted=2&_r=2 (Jan 7th, 2009)
The article refers to Symphony Hall, in Boston, as the best in the world.
http://www.iconeye.com/index.php?option=com_content&view=article&id=2618:casa-da-musica--icon-024--june-2005 (Jan 6th, 2009)
The article refers to Musikvereinssaal, in Vienna, and Concertgebouw, in Amsterdam as having great acoustics in the world.
http://www.ark.fi/ark4_96/acoustics.html (Jan 7th, 2009)
The article refers to Symphony Hall, in Boston, and Musikvereinssaal, in Vienna, and Concertgebouw, in Amsterdam as the very best.
21. M. David Egan, Architectural Acoustics, Fort Lauderdale, J. Ross Publishing, 2007, p52
22. M. David Egan, Architectural Acoustics, Fort Lauderdale, J. Ross Publishing, 2007, p52
23. Marshall Long, Architectural Acoustics, Amsterdam, Boston, Elsevier / Academic Press, 2006, p373
24. Marshall Long, Architectural Acoustics, Amsterdam, Boston, Elsevier / Academic Press, 2006, p373
25. Leo Beranek, Concert and Opera Halls: How they sound, Acoustical Society of America, 1996, p489
26. Part of William Wordsworth's poetry titled, 'The Solitary Reaper', 1805
27. Marshall Long, Architectural Acoustics, Amsterdam, Boston, Elsevier / Academic Press, 2006, p371
28. Marshall Long, Architectural Acoustics, Amsterdam, Boston, Elsevier / Academic Press, 2006, p372
29. CATT-Acoustic (Computer Aided Theater Technique) is a simulation tool used by acousticians: Changes in the results obtained when altering computer models are analogous to real-world changes.
30. Henry van Dyke's hymn, 1907, the music for which is from Ludwig van Beethoven's 9th Symphony

Illustrations

1. Grosser Musikvereinssaal, Vienna, Austria:
<http://www.worldwideticketing.com/images/vienna%20concerts%20vienna.jpg> (Jan 5th, 2009)
2. Symphony Hall, Boston, USA:
<http://graphics8.nytimes.com/images/2007/06/03/arts/03kram.jpg> (Jan 6th, 2009)
3. Concertgebouw, Amsterdam, Netherlands:
http://www.hpho.nl/Afbeeldingen/HPhO_photo_concertgebouw.jpg (Jan 6th, 2009)
4. Site Plan: Concert Hall for Symphony Orchestra and Choir:
Source of drawing used in developing the site plan for the concert hall:
http://www.gis.lib.vt.edu/gis_data/Blacksburg/GISPage.html (June 1st, 2008)
5. Adapted view: Concert Hall for Symphony Orchestra and Choir:
Source of background image used in developing the view for the concert hall:
http://wallpapers.free-review.net/wallpapers/42/Ocean_Hope.jpg (May 1st, 2009)

All other illustrations are the author's work.