

The connection between the steel ribs and the concrete arches was critical. In order for the concept of a subtle threshold to be successful, the two elements, land and water, would have to come together in a fluid, almost blurred manner. This connection would transform the duality of the two elements into a union, which would create the threshold of river from land. The drawings show how the ribs would meet the cantilevered arms of the arches and how the ribs would meet the earth.

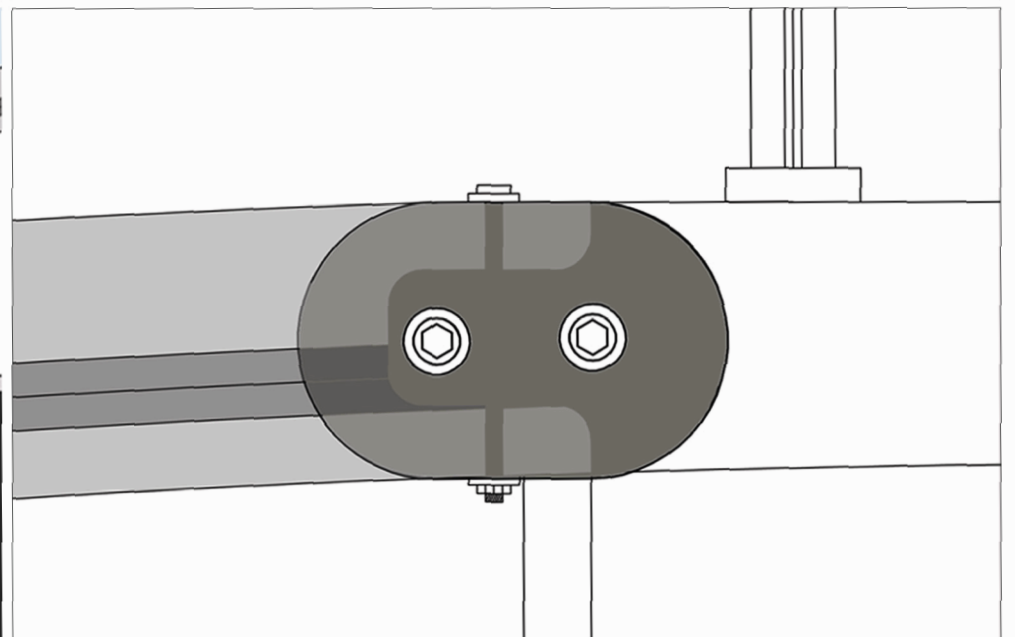
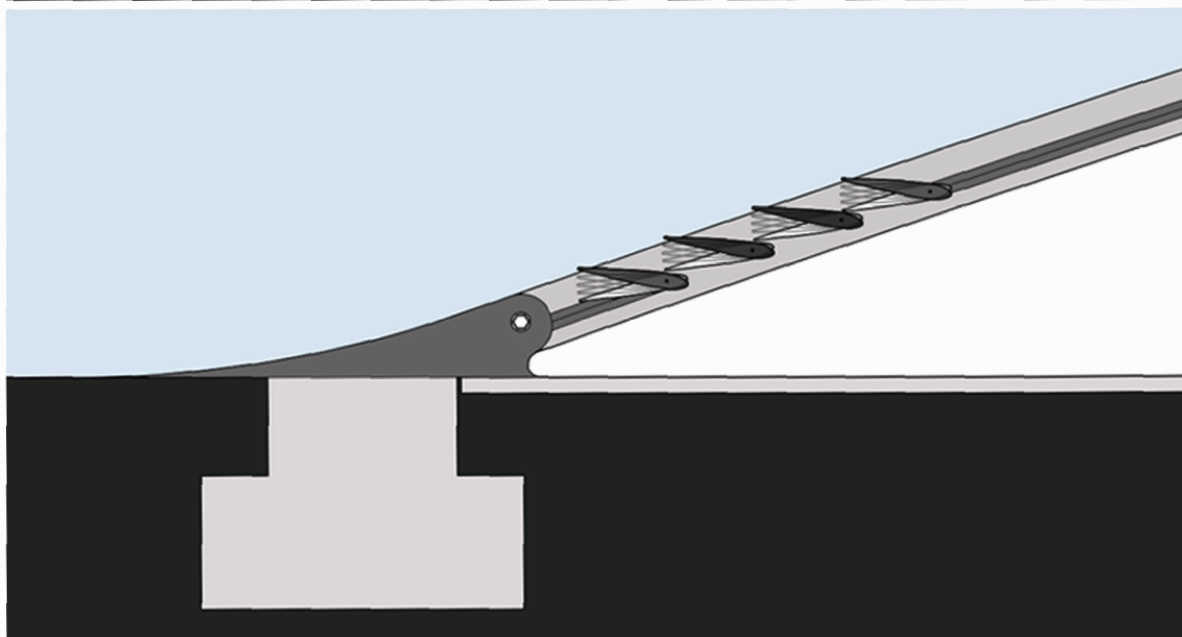
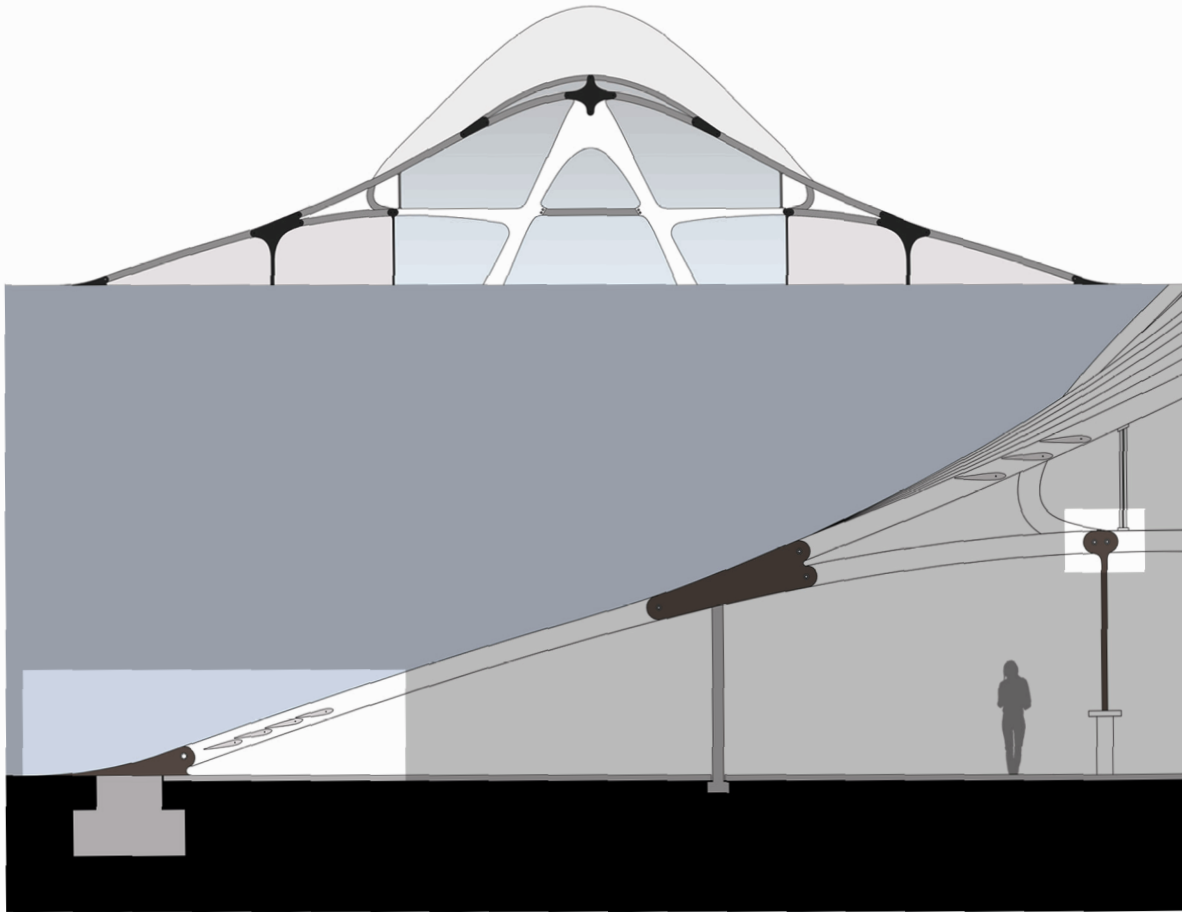

When considering the ventilation for the building, I envisioned it to be an arterial system. All the ventilation ducts would run through the concrete arches. This would allow for radiant heating of the concrete mass, along with direct airflow of hot or cold air.

Also, the incorporation of night cooling could be achieved through air intake in the service corridors at the edge of the building where the hvac is located. The hvac's fan would then force cool outside air to circulate throughout the building's thermal mass, the concrete slab floor and concrete arches, and allow warmer air within the building to escape out the roof. This same design would allow for natural ventilation during temperate weather. Due to the direction of summer winds, the air mass would be forced over the building, creating negative pressure due to the Bernoulli effect, thus drawing out warm inside air. Also, the stack effect would allow warm air to rise through the center of the building and escape out the roof vents.

Wind data from Dulles Airport

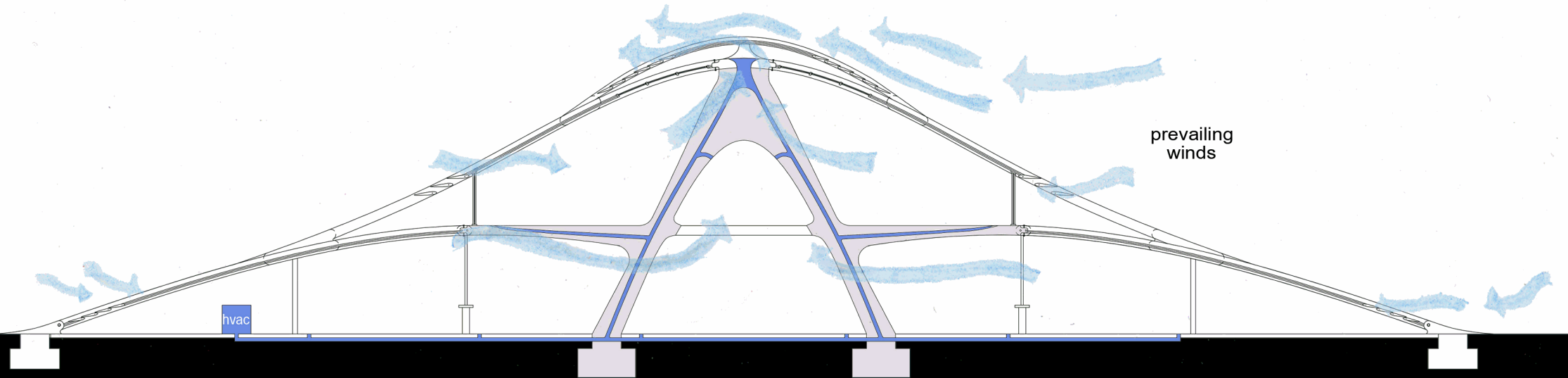
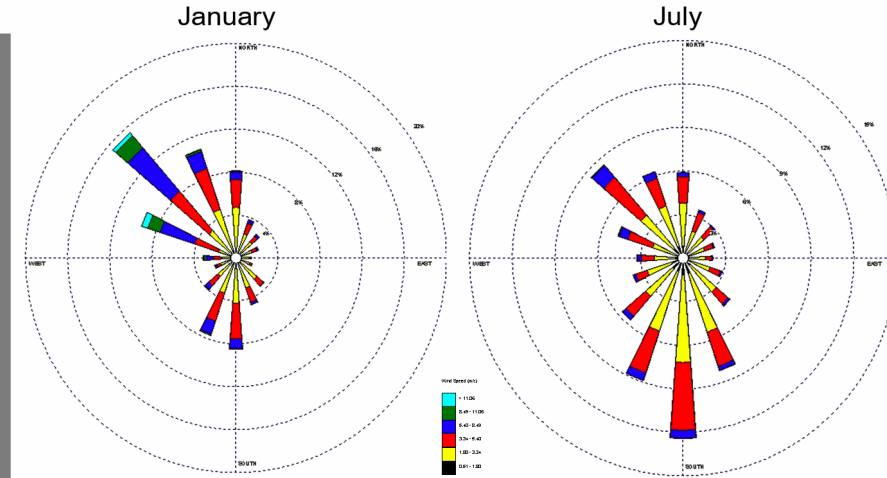

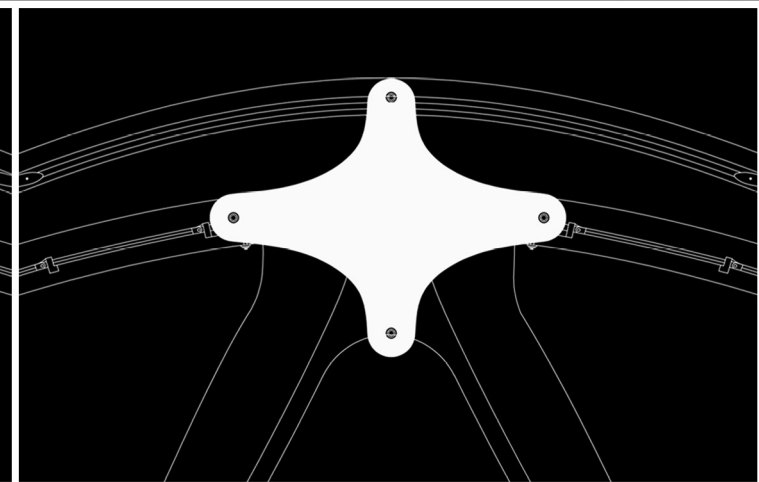
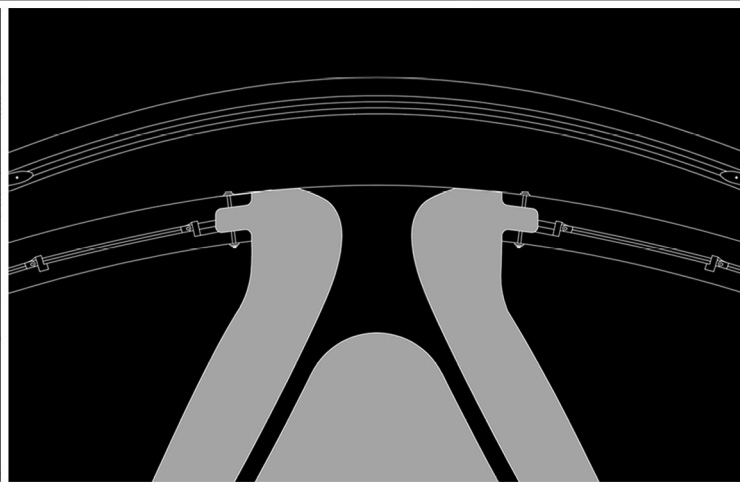
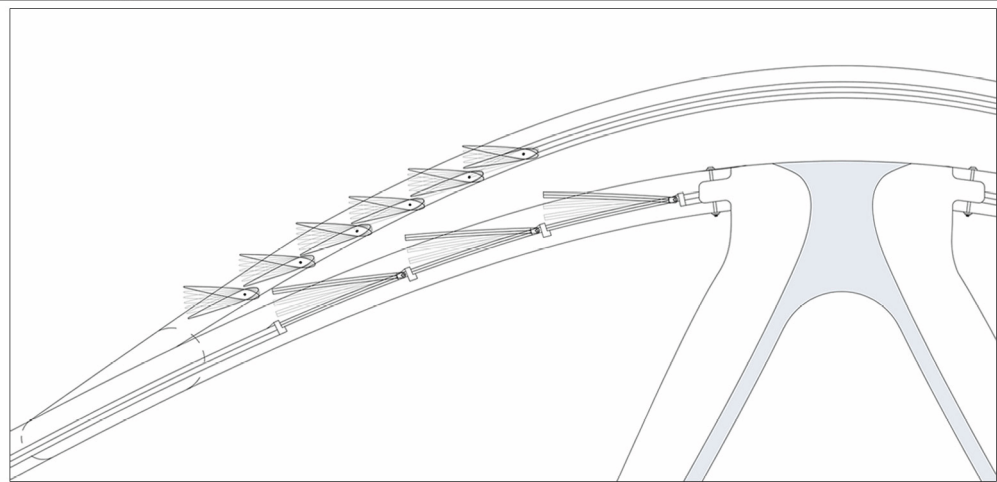
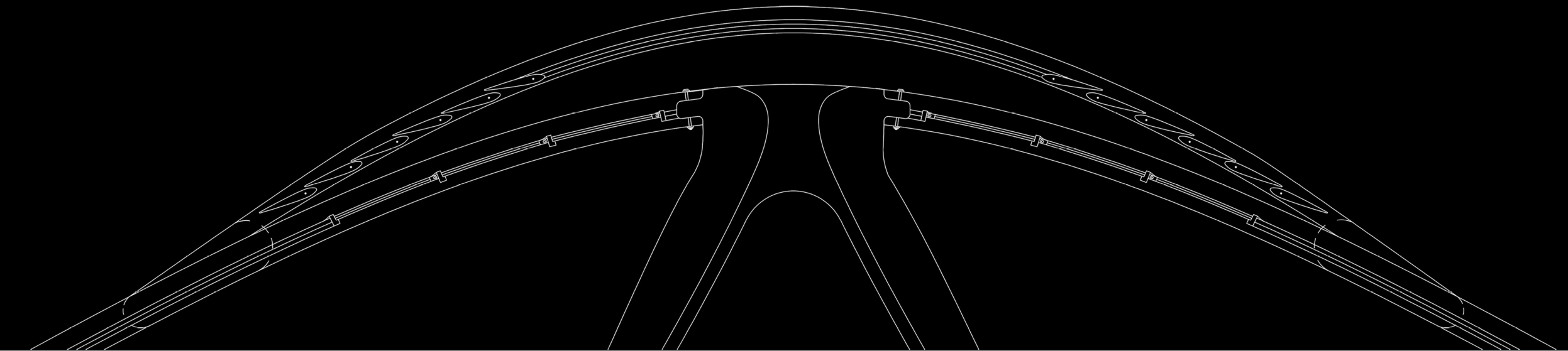

In order to allow for natural ventilation and to have outlets for air exchange in the ventilation system, openings were needed in the roof. To accomplish this without losing the integrity of the pure curved roof surface, operable horizontal louvres were placed on either side of the peak of the roof. Casement windows were placed underneath this outer roof layer. The upper steel member is connected to the lower steel rib, which is then bolted to the peak of the concrete arch. A large gusset would cover this connection, emphasizing a moment in the building when the two elements come together.

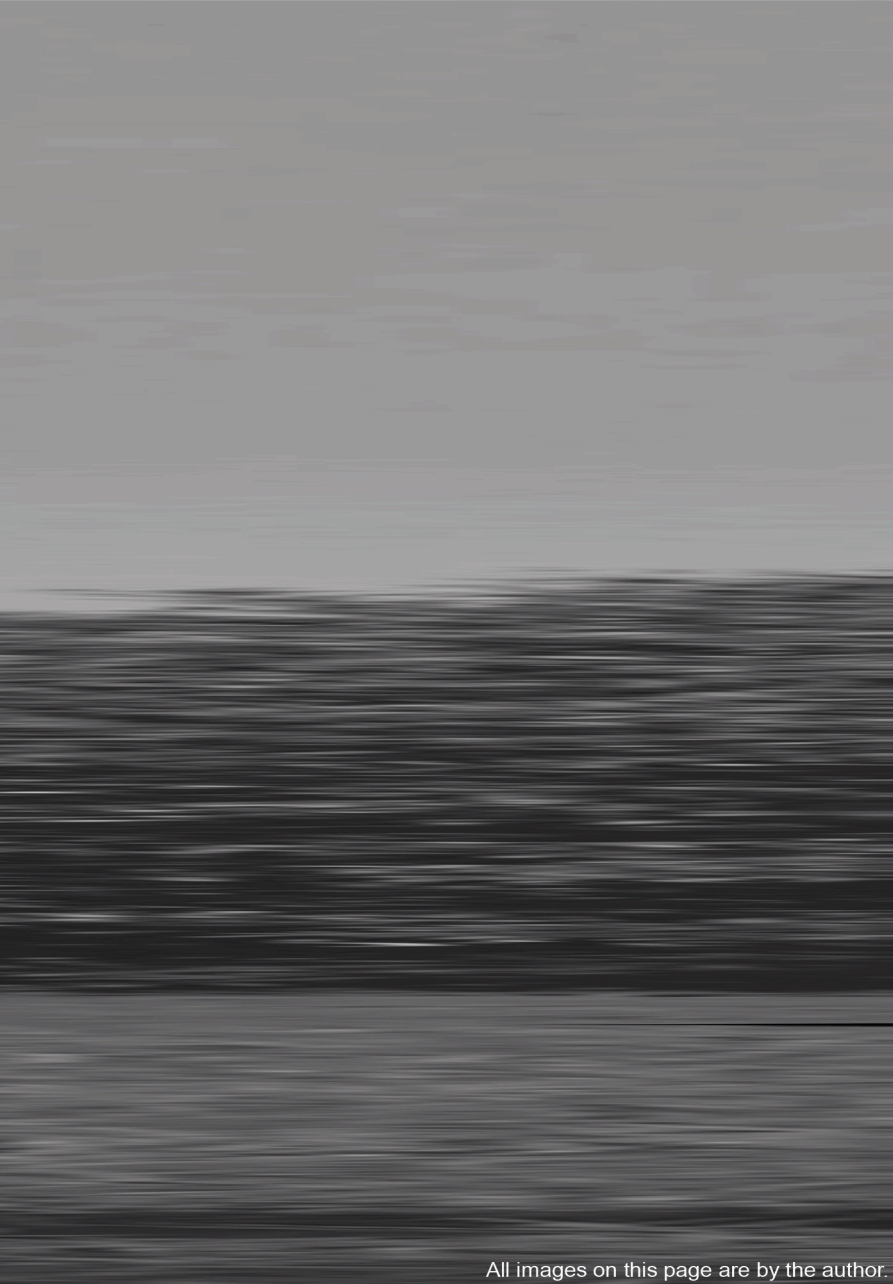

All images on this page are by the author.



The construction of the concrete arches had to be considered in order for the proposal to be feasible. An initial idea was to use precast concrete and then assemble the pieces on site. Due to the size of the largest arches, transportation of the pieces could pose a problem. The idea of cast-in-place concrete construction seemed to be the most realistic. By using plywood to construct the formwork, one could attain the curvature of these forms. The concrete was to be white, in order to contrast well with the steel ribs.

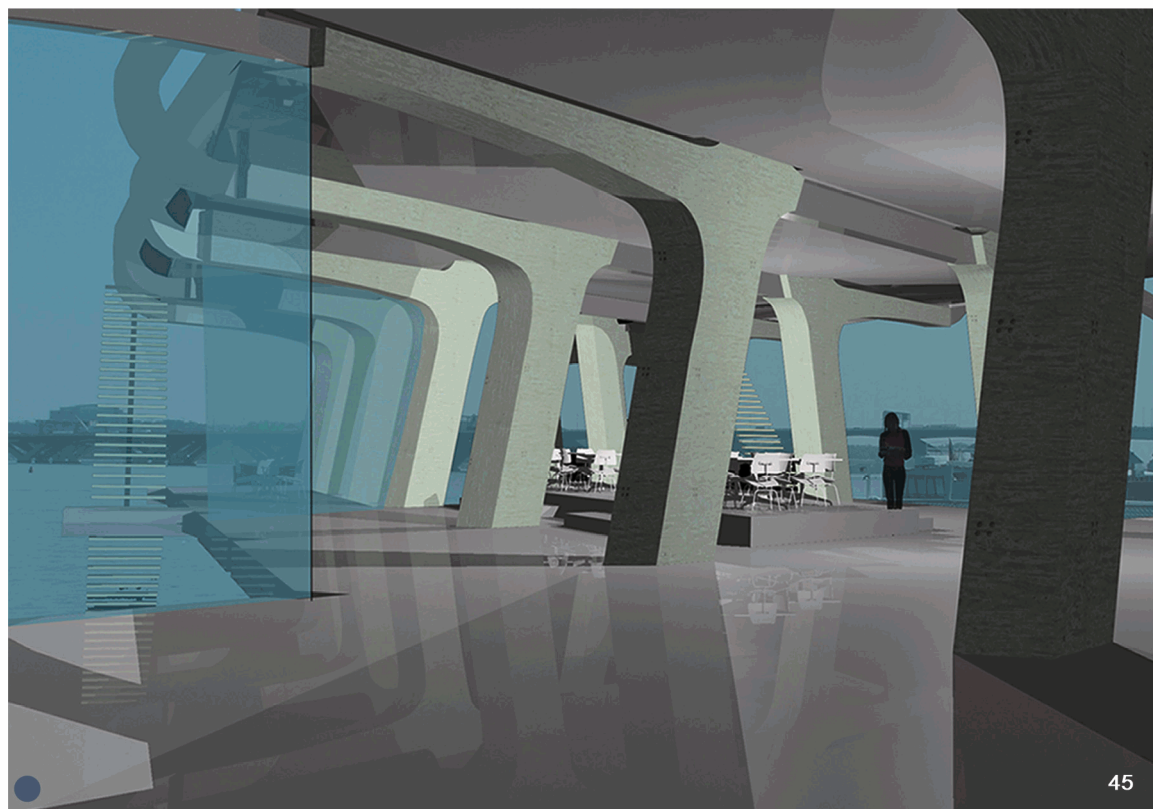
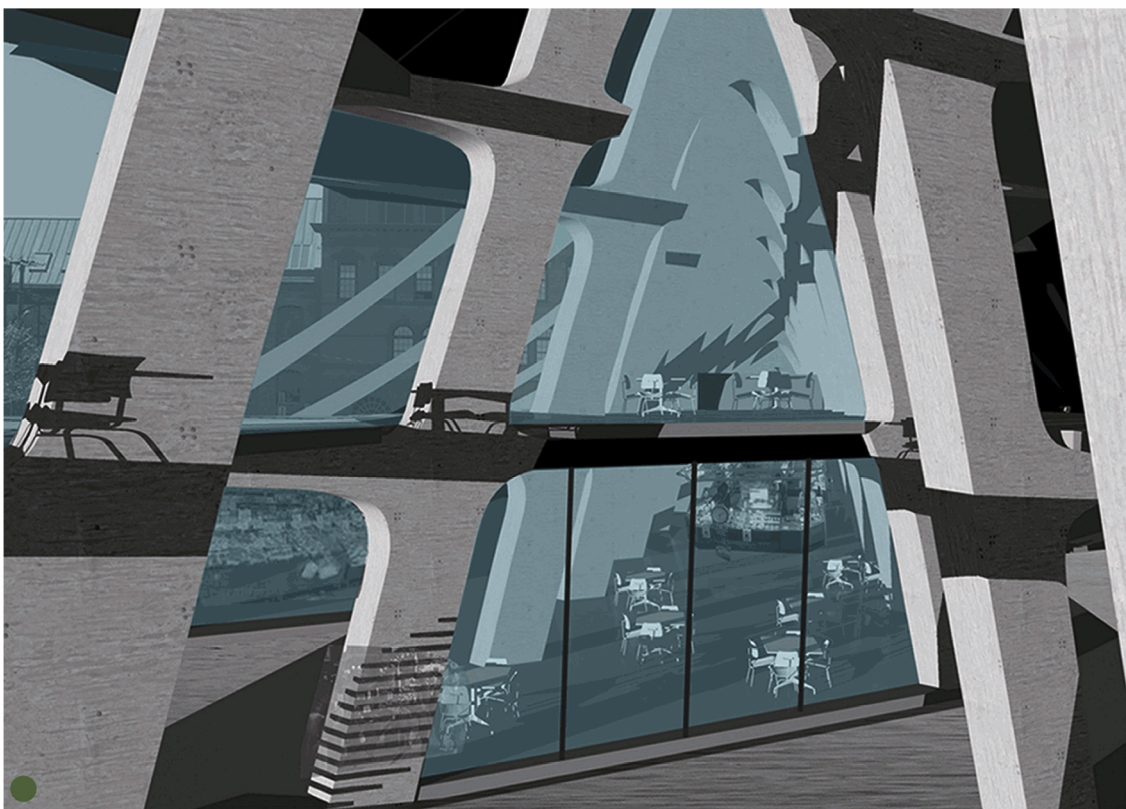
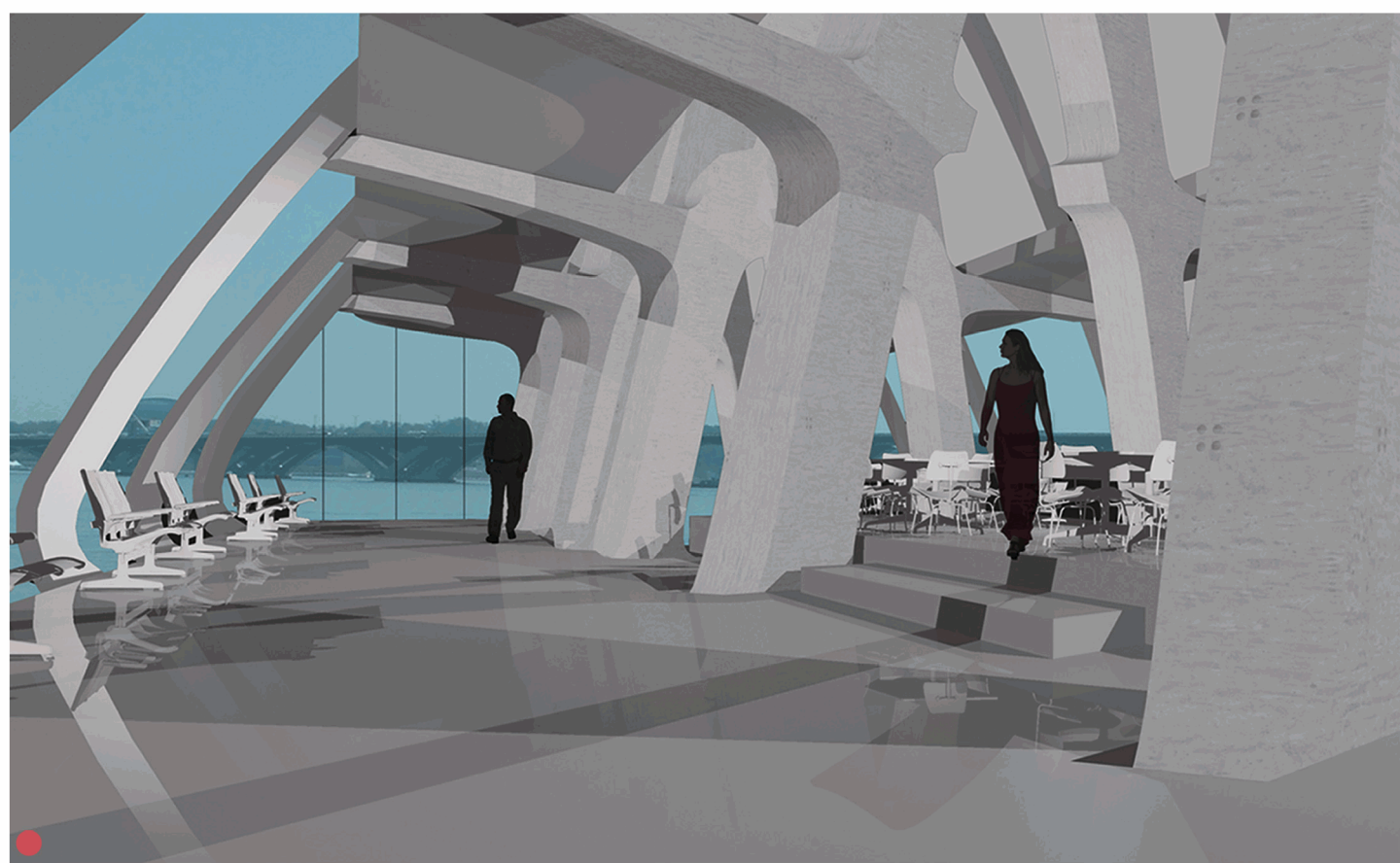
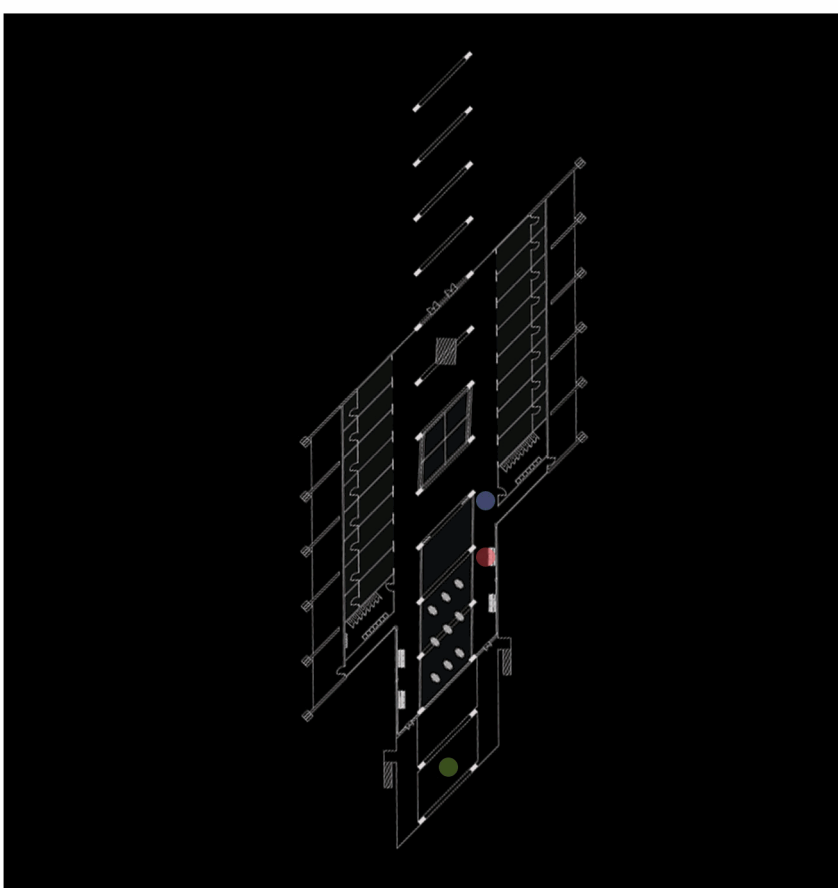

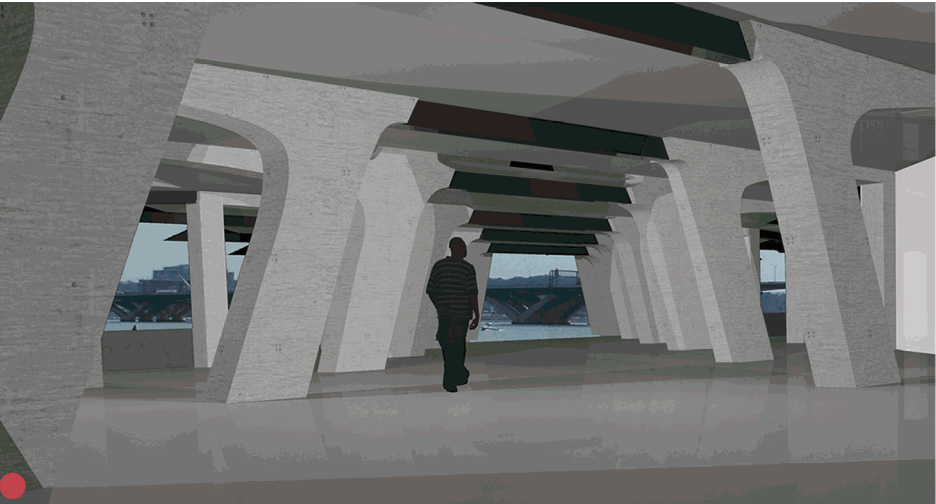
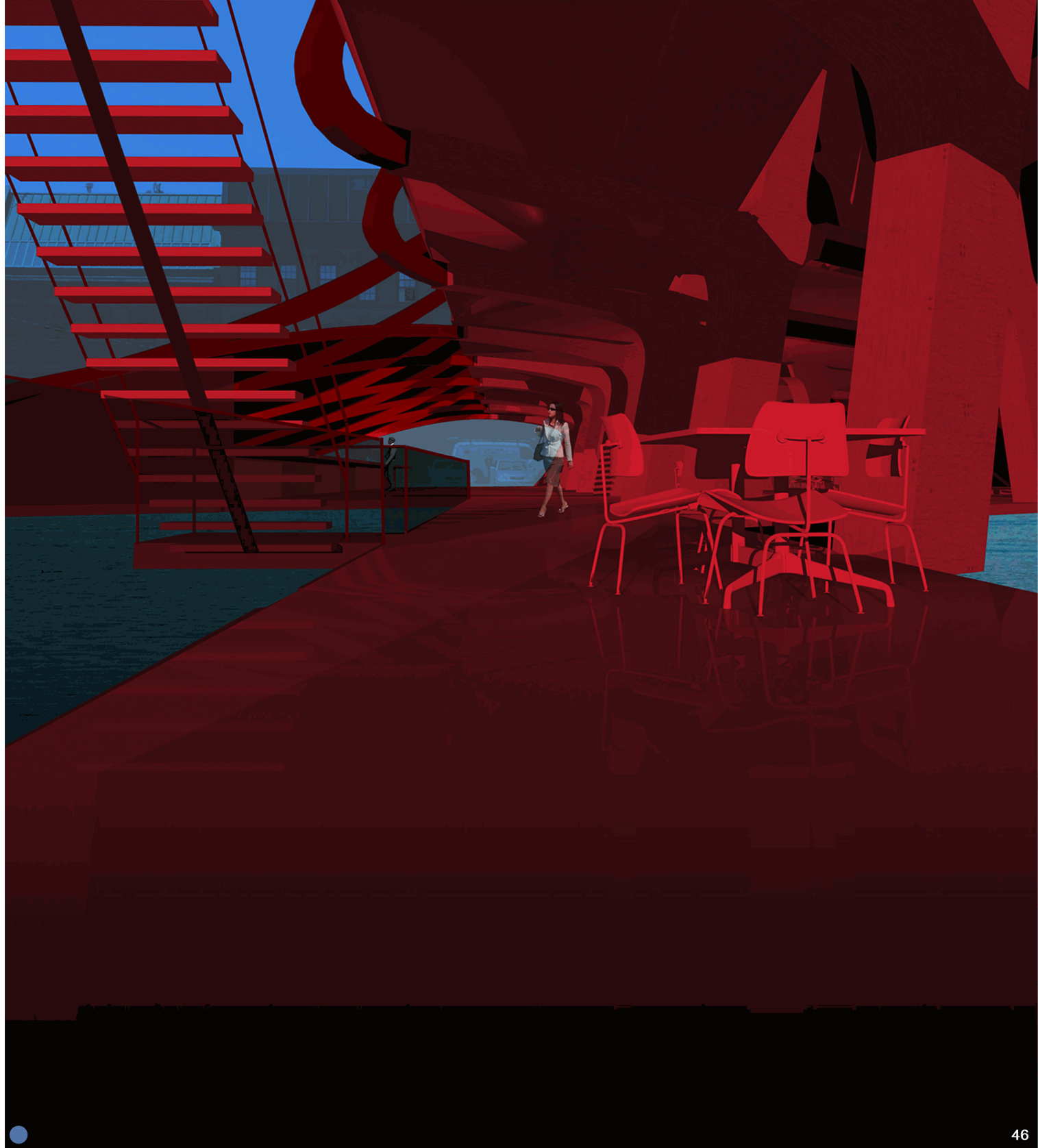
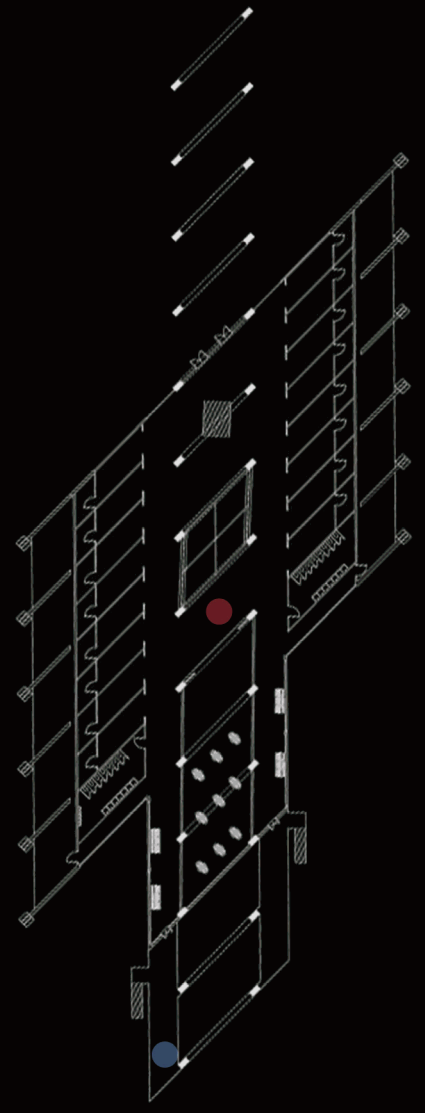

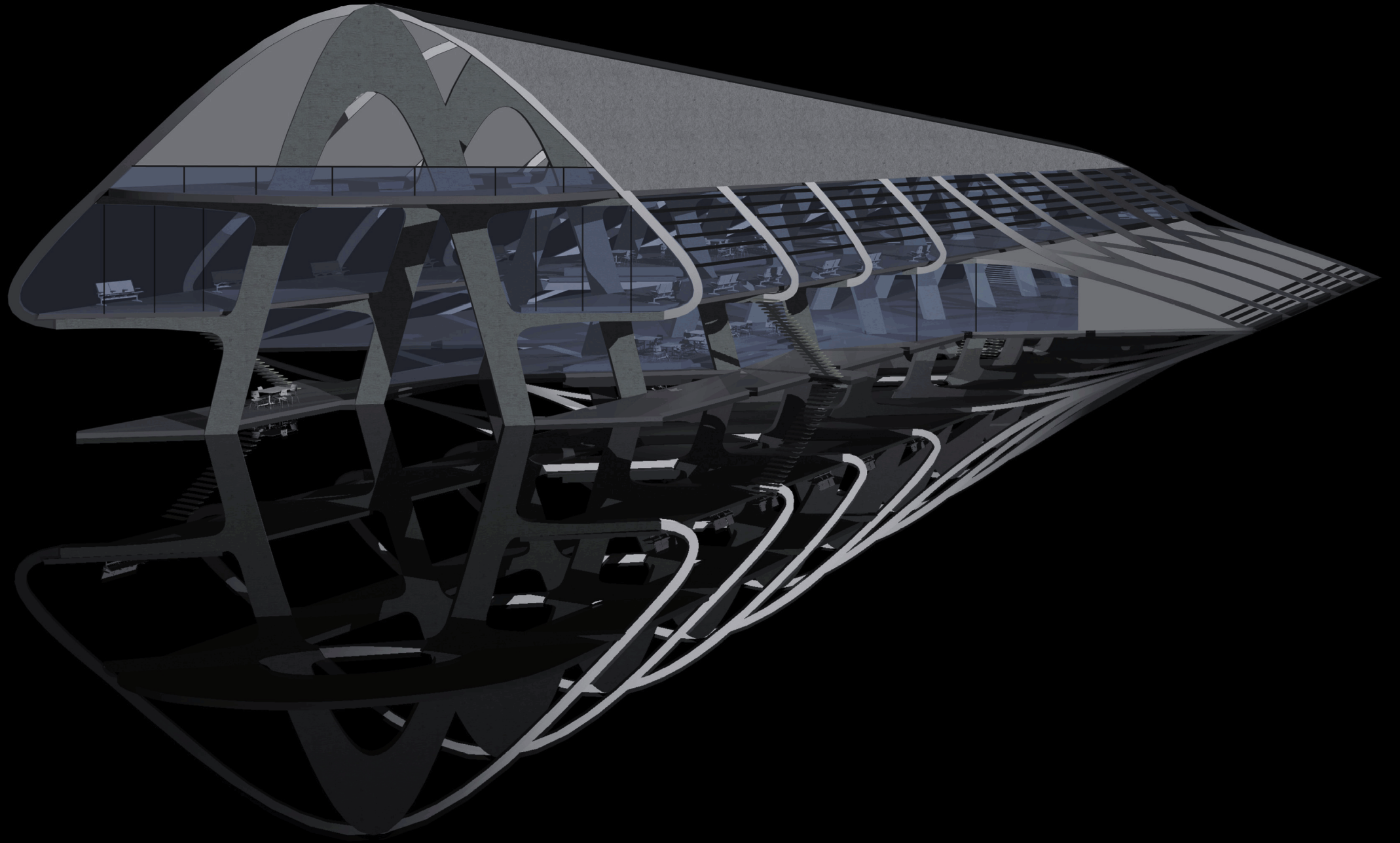



This image is by the author.

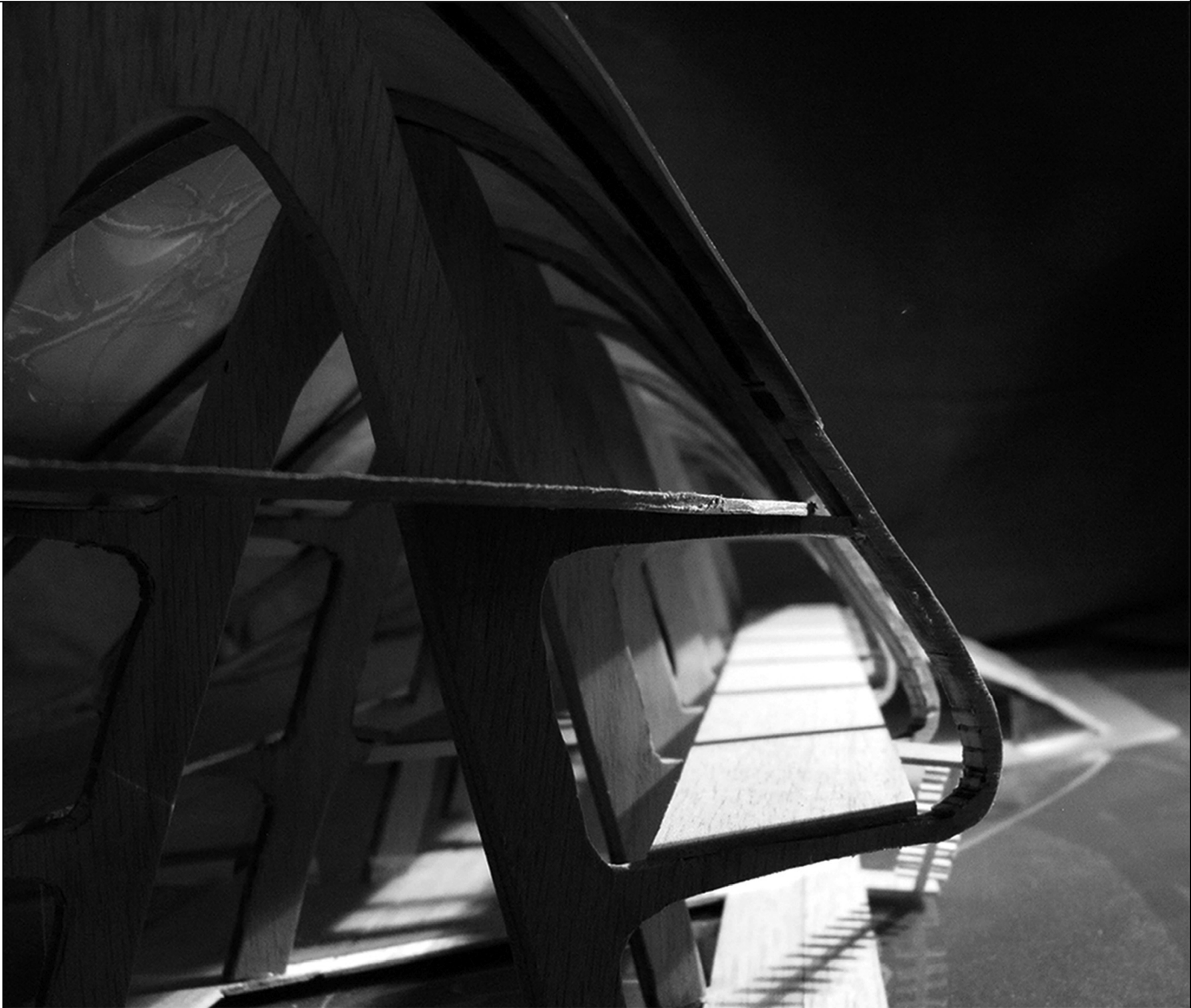

This image is by the author.



This image is by the author.

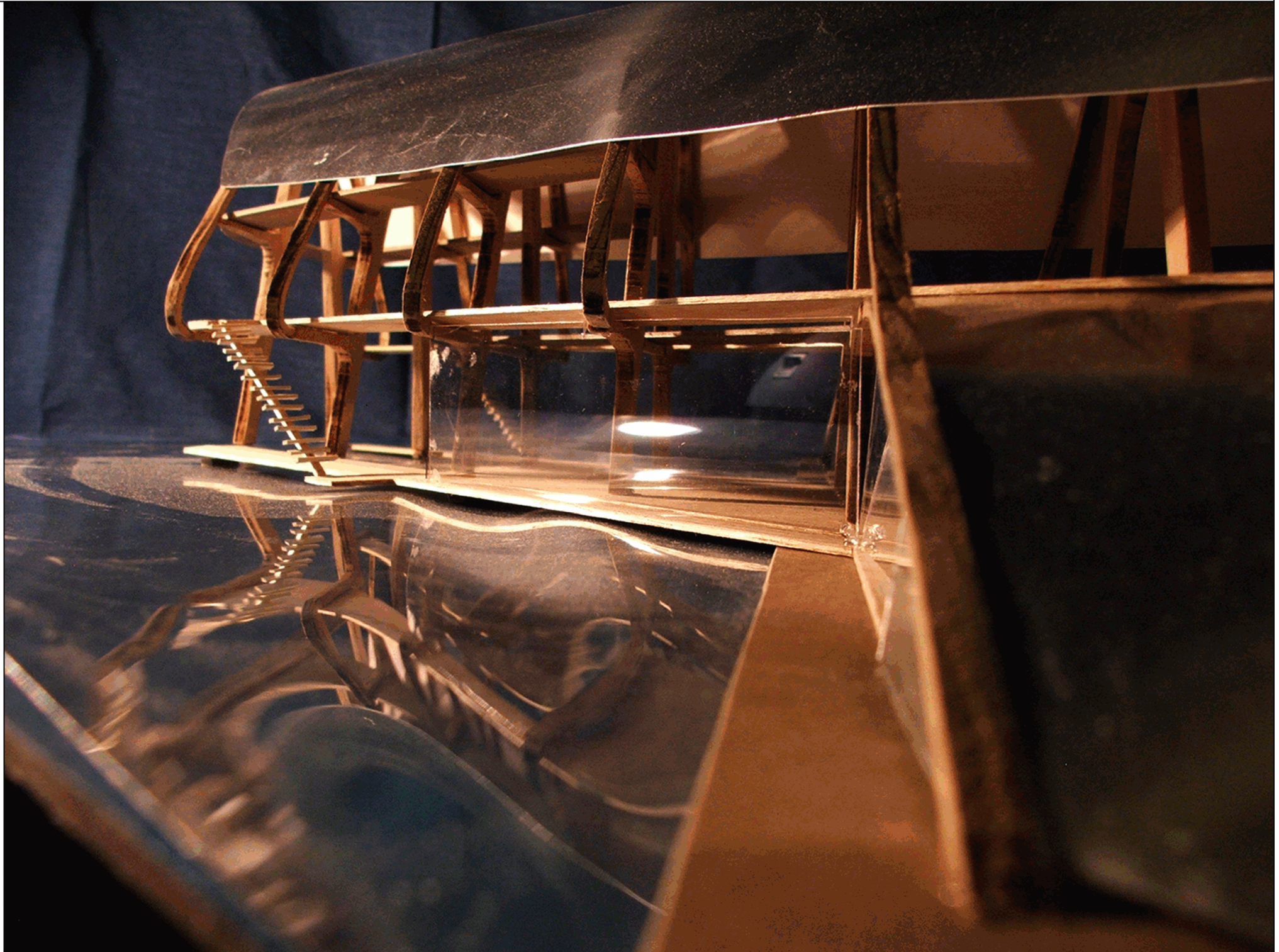

This image is by the author.



conclusions

Is it possible to create a threshold from a duality that also becomes a union? Through my explorations in this project I have attempted to respond to very distinct environmental conditions. For me, this was a very rewarding approach to design. When our surroundings influence our identity, there is a celebration in regionalism that transcends human ego. When duality eludes separateness, a threshold of unity arises.

Works Cited

1. "Alexandria, Virginia." Wikipedia. 17 Oct. 2007. <http://en.wikipedia.org/wiki/Alexandria,_Virginia>.
2. Adapted from: Historical Materials from Alexandria Archaeology Museum. Alexandria, Virginia. 5 December 2007.
3. Zucker, Paul. *Town and Square From the Agora to the Village Green*. Cambridge: M.I.T. Press, 1970.
4. Adapted from: "Alexandria by Water". Map. Potomac Riverboat Company. Alexandria, Virginia.

All other images contained in this book are the author's own photographs or drawings.

