

... dedicated to my soulmate with tremendous love and appreciation



**crys.tal.line \_a quest in realms of structure, skin and space**

thesis submitted to the faculty of virginia polytechnic institute

---

William Galloway (chairman)

William Brown

May 2000

by **selin ozertugrul**

in partial fulfillment of the requirements for the degree of **master of architecture**

---

**Jim**

**Jones**

**Heinrich**

**Schnoedt**

8. abstract... 13. genius loci... 26. light... 32. crystalline... 35. layers of wall.. 52. ribbon wall ...

chair  
lamp

understanding new york  
evolution of the site  
challenging the site

sculpturing with light  
light studies

ribbon wall  
folded wall  
atrium wall  
wall of columns

stacked versus woven  
ribbon structure  
joint versus break

evolution of folded wall  
dualities

wall versus frame  
structure and skin

64.folded wall... 72.atrium wall... 78.wall of columns... 86.addendum... 94.bibliography... 98. vitae

framing view  
path  
interlocking space



the initiatory moment of this thesis is an image of a **chair**. it is the inspiration for the primary steps of the study, which opened up in manifold paths in the realm of architecture. the 'chair' as an object displays the articulation of **frame** and **skin** interdependently. its vague contours proclaim the elements of architecture of which it is formed, and those elements form the 'space' concertedly. the project, stemming from this assertion, searches, explores and articulates the intricate relationship between structure, skin and space as prominent elements of architecture.

the design of the **lamp**, as a leading step of the exploration, inquires into the interdependence of structure, skin and space through the interplay of light, shadow, transparency, translucency and reflectance. the overlapping **layers** of **skin** become a veil draped around the thin metal spine of the lamp. it displays degrees of translucencies versus the direct illuminance through the open ends and reflected light from the polished aluminum base. the luminous object thus becomes the tangible demonstration of the complexity inherent within the simple interrelations of these elements.





the lamp designed  
by the author

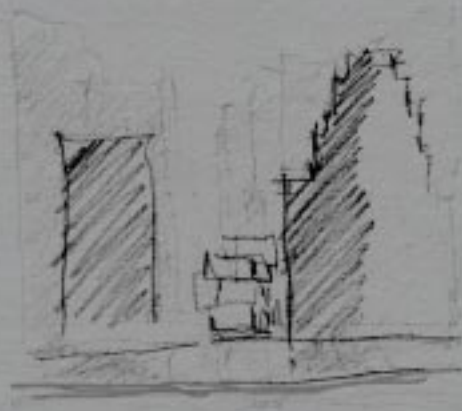

...challenge the site, as harmonize it, too. It



genius loci

light

crystalline

## u n d e r s t a n d i n g   n e w   y o r k

the history of the rock island starts as a company town and turns into the financial and entertainment center of the world. the **grid** system which was proposed to form an homogeneous, neutral background for all communities coming from all over the world also became the ground for the accumulation of the **skyscrapers**. the skyscrapers originated as a response to the unexpandable nature of the island and the increasing space demand of its growing population. soon they were shaped as a reflection of the idea of 'city within a city'. they promoted disconnected lives in their stacked up floors, and they deserted the street life. together they form one of the most dense urban settlements of the world while casting shadows over the streets and the neighboring buildings. "...the city as a complex outcome of confrontation between power of money, egocentricism of architect and laws to the extrusion of the land..." 2

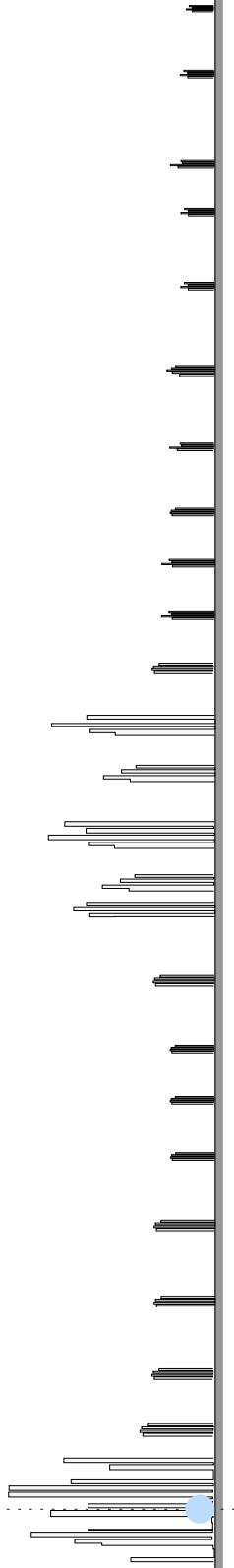
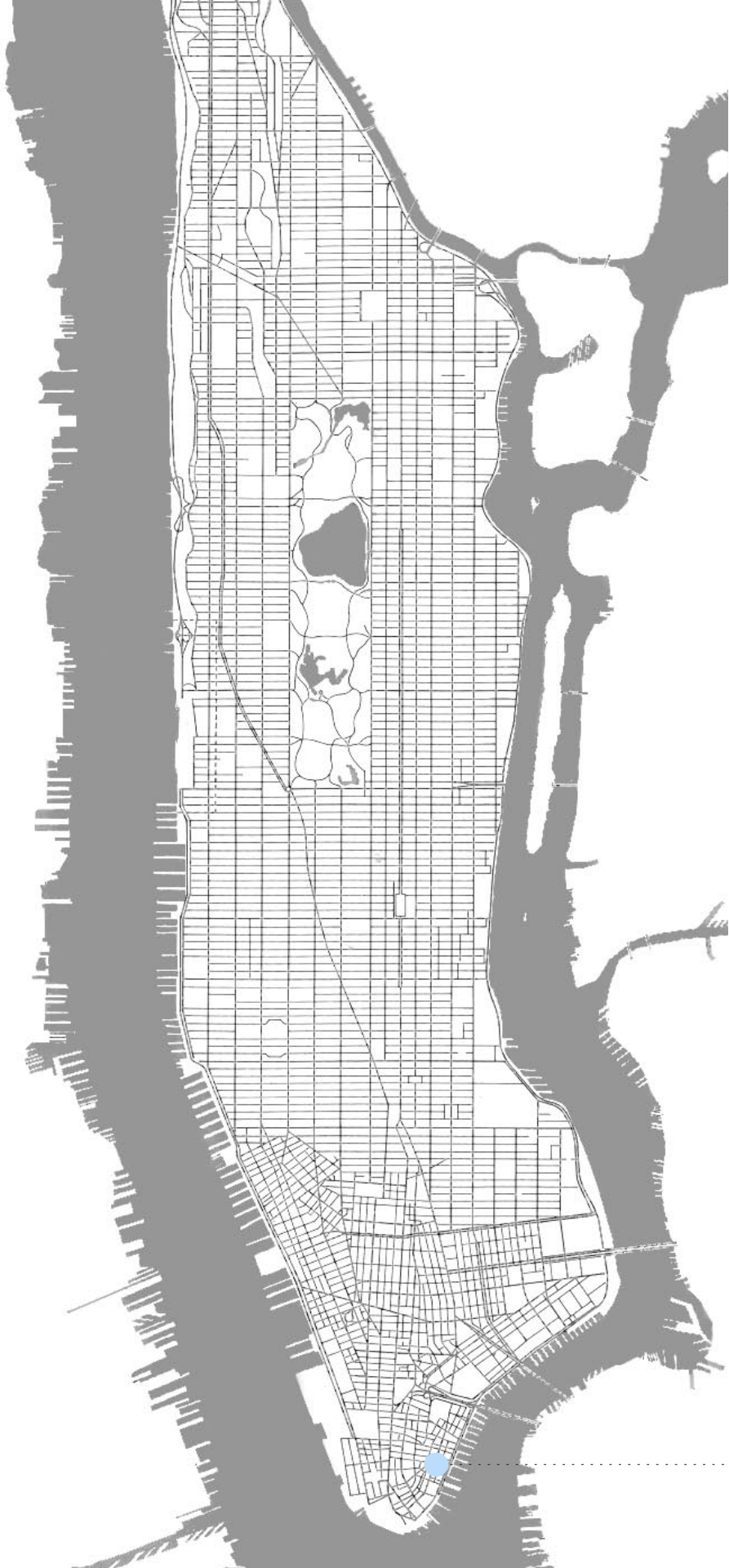

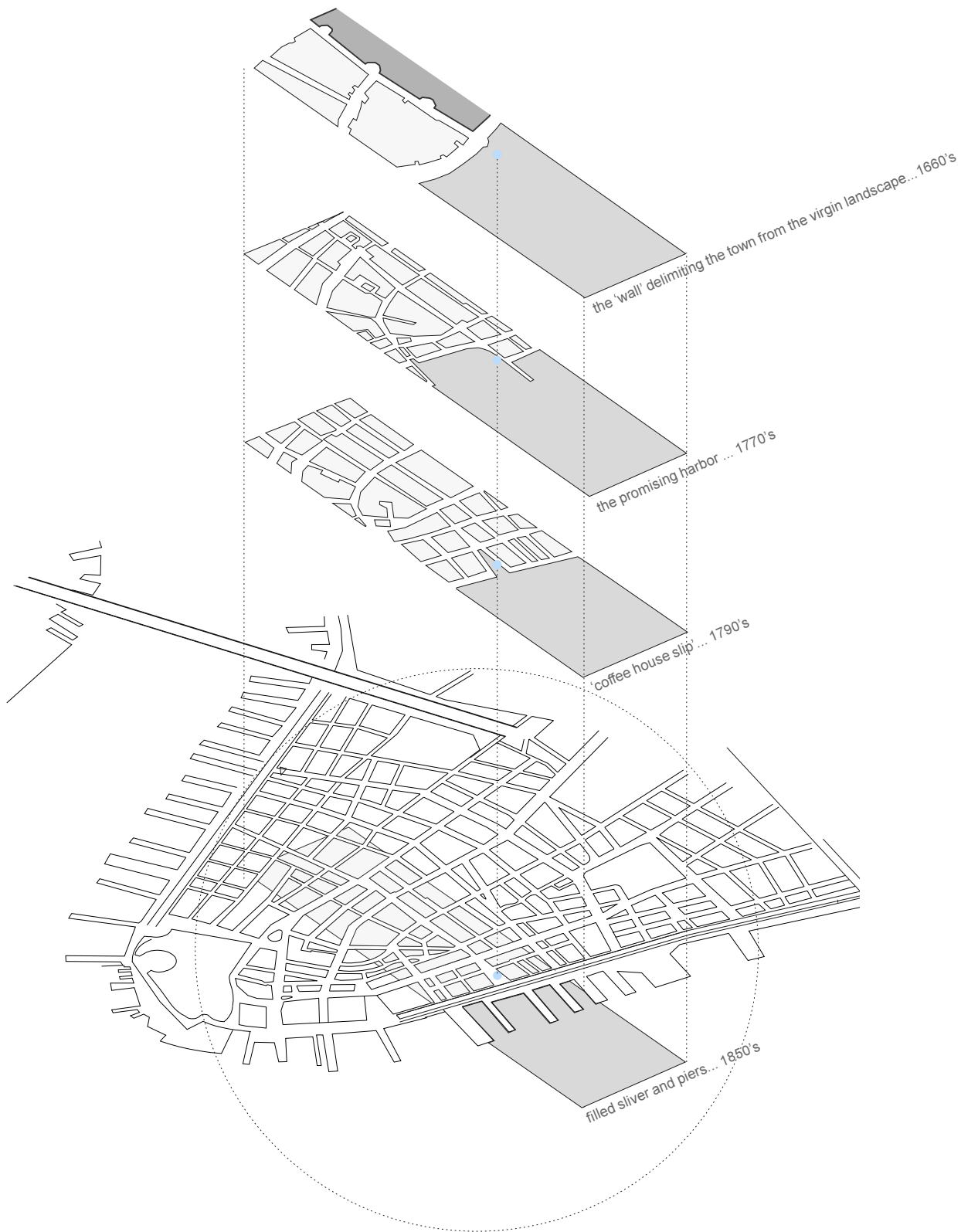



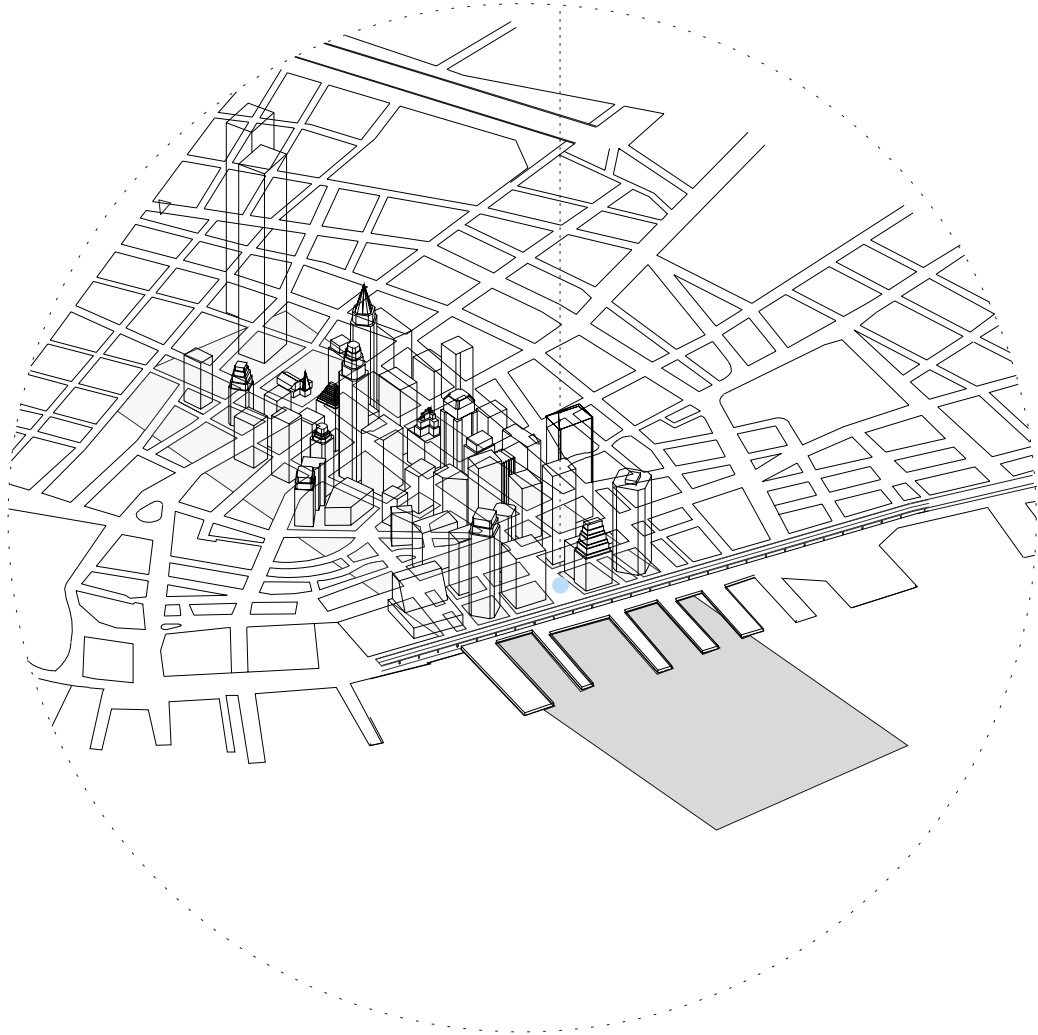

#### t h e e v o l u t i o n o f t h e ' s i t e '

the **water edge** of manhattan reflects the transformation of the island over the centuries, from a trading harbor to a village and then finally to a metropolis. the city conceals its past as the physical evidence of this history has been buried. the heights of the internal topography were levelled in order to achieve the ideal flat plane for real estate development. the boundaries of the city were expanded as the buildings were demolished, and the soil from levelling was thrown on the shoreline for filling. the 'site', which was part of the **east river** in the 16th century, was transformed into a harbor by the 1770's and into a slip for ships by the 1790's after ongoing **landfill** projects. the little sliver was filled by the 1850's, and the site took its present the state by the addition of the piers along the east river side.



# c h a l l e n g i n g      t h e      s i t e

"...can a residential neighborhood be carved out of the financial district?..." 3

**lower manhattan** embraces the primary footprints of New Amsterdam, subsequently to be named as the 'world metropolis', New York City. the **integral village** founded on the principles of commerce was the melting pot for numerous cultures, religions and architectural expressions as a consequence of the trade-driven development of the village. the social and economical dynamics of new amsterdam transposed the village, which housed mixed uses of daily life, into an isolated community of banking and an investment center in the coming centuries. the life of the district was mastered by economic fashions. the ups and downs of the rough real estate milieu soon abandoned the powerful marks of the high-rise era. the search for a new **urban neighborhood** offers a great opportunity to transform this district once again. **wall street**, which originated as a wall built by the Dutch as the 'edge' of new amsterdam in the establishment of the new city, forms the core of the region and retains the potential of being the core of the new transformation into the village character. the **virtual downtown** is evolving as the information media establishments are now expanding and converting the abandoned office spaces, with high ceilings, punched windows and hardwood floors, into the creation center for cyber space. further changes can be characterized as "what's hot on wall street? is the conversion of the historic buildings and even modern office buildings into chic, loft-like, very 'today' residences."<sup>4</sup> the challenge is to overlap and shift the rich and complex neighborhood spirit with work and life for the pursuit of **real downtown**. so the program of the proposed building is developed to promote this transformation. in it dwells information media offices, apartments and galleries with a store and a cafe, all of which are located "on various floors, but are interlocked spatially. "... the **site** is on the end or on the beginning of the 'canyon' anchored with **trinity church** on the other end of wall street ... the small sliver on the street offers the challenge of 'presence' under the shadow of overlooking gigantic masses..."<sup>5</sup>





manhattan and the site

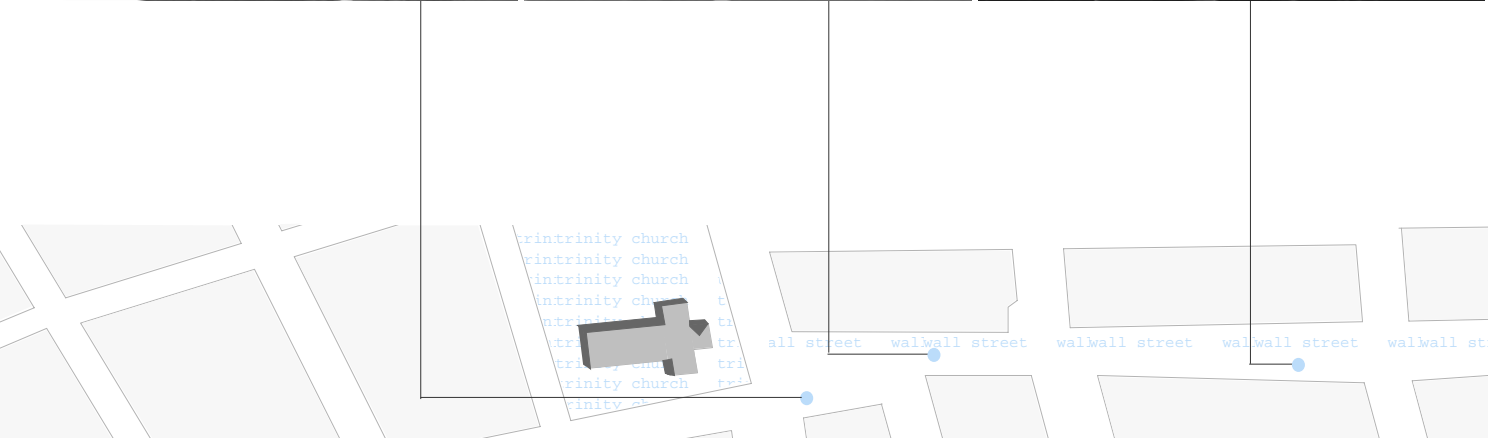

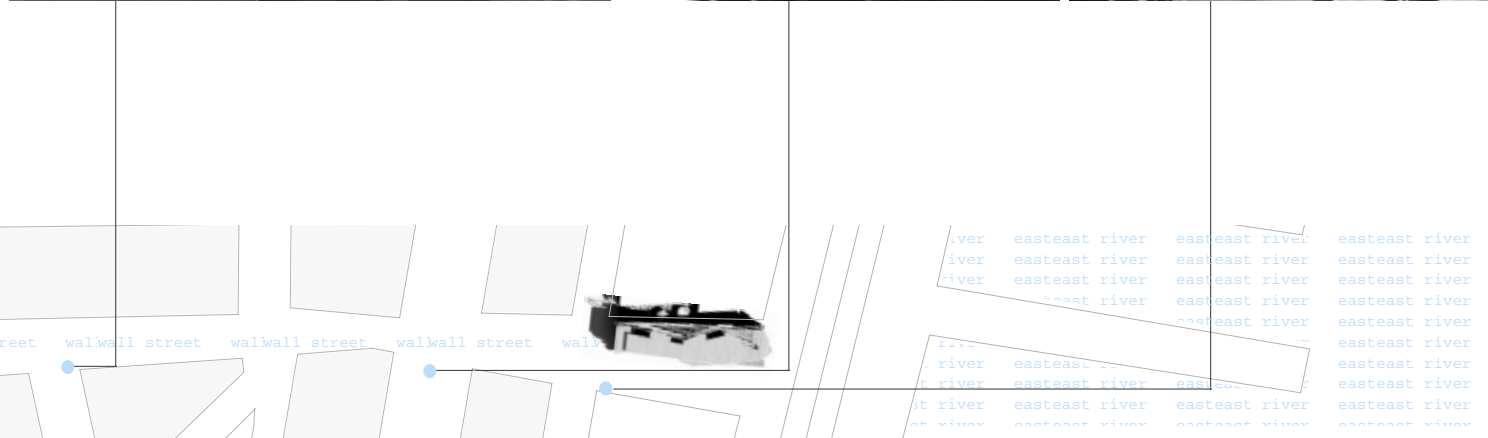

One of the challenges of designing on the particular site is its small scale in comparison to the monumental scale of the neighboring buildings. trinity church stands out as the only reference point regarding the scale on wall street. the site and trinity church are both located on the central axis of the street marking either its end or its beginning.





"...site at the end of wall street, or at its beginning, a site with as much potential significance as trinity church..."<sup>6</sup>

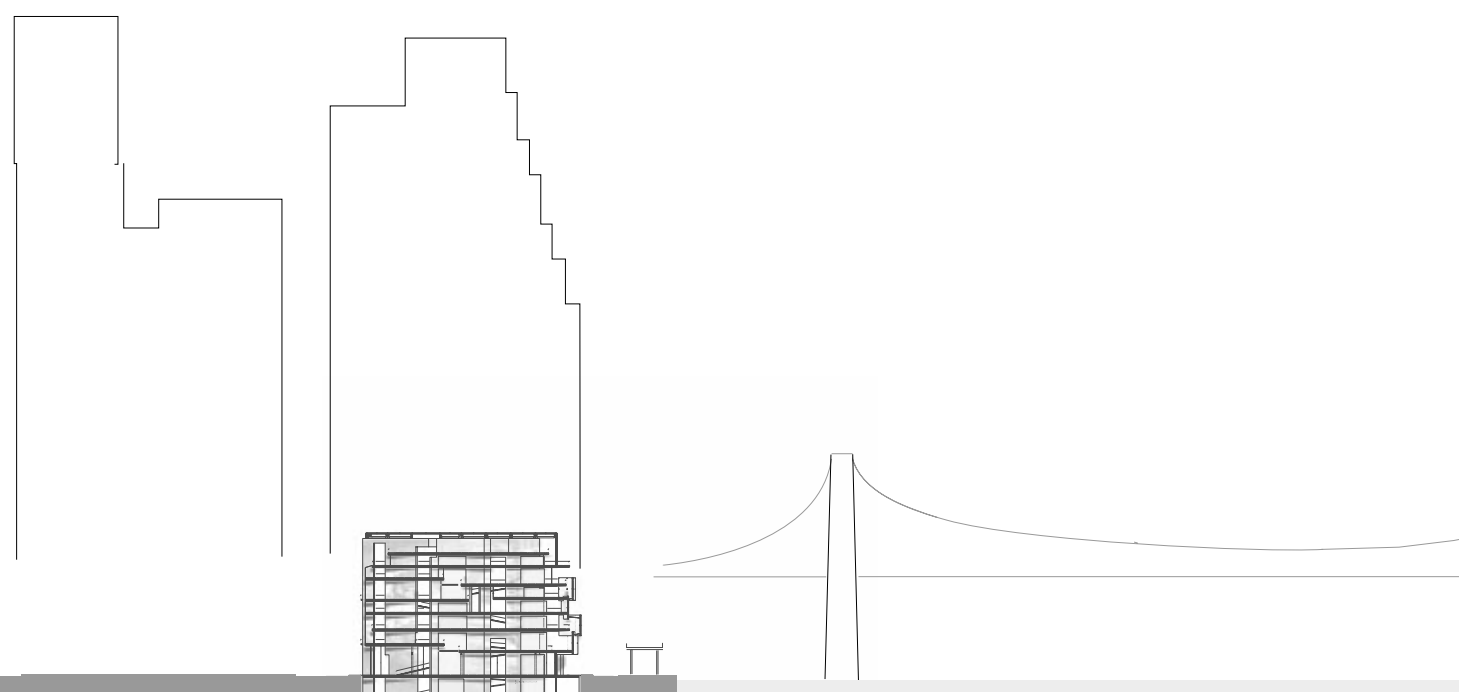

street wall street wall street wall street wall street wall street wall street wall street wall street

POSSIBLE GEOMETRIC

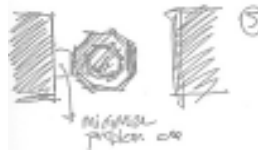
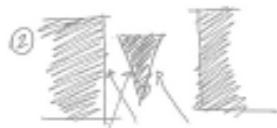

## s c u l p t u r i n g (w i t h) l i g h t

'luminous bodies' ... "...by day the city fills with energy. by the night, it disperses its vitality in the network of automobile lights, the glowing appeal of commercial advertising and in the verticals of skyscraper lights... the contours of the buildings are erased. but in one's consciousness they still rise, chase one another, trample one another..."<sup>7</sup> a significant challenge for building an artifact in new york city is how to conduct natural light to the edifice itself and simultaneously to permit an adequate amount of light to the neighboring ones. in the city of towers, good architecture has to take into account **light** and **air**. **shadows** dominate the streetscape. the 'canyons' are created by gigantic extruded boxes lined up along the streets of the rock island. sunlight is restricted more and more as buildings grow taller. the demand for light has been shaping the evolution of skyscrapers in the new york city skyline. **tapering** high rises are sculptured by the setback regulations of the **zoning laws**. the ziggurat-like forms, with stacked up floors, are the direct consequence of enclosing the maximum rentable space. these masculine buildings set on the ground with solid presence, and their tops diminish towards the sky. the peculiar setting of this site, being at the end of wall street where it opens up to air and light, brings up the challenge of **capturing** light for the proposed building itself, **reflecting** and **improving** the situation with respect to light for the neighboring buildings, particularly the adjacent 1930's skyscraper. this established one of the primary motives for design.

28 | "...open space on wall street is often just a



glimpse of sky between skyscrapers..." 8

the light well in



plan versus section



l i g h t s t u d i e s f o r t h e s i t e

the dominating contours of shadows over the streetscape and the buildings of wall street were examined for the most and the least favorable conditions regarding the access to light and air year-round. june 21<sup>st</sup> is set as the reference for the most desirable summer situation versus december 21<sup>st</sup> as reference for the least desirable winter situation.

30

december 21, 10.00 a.m.

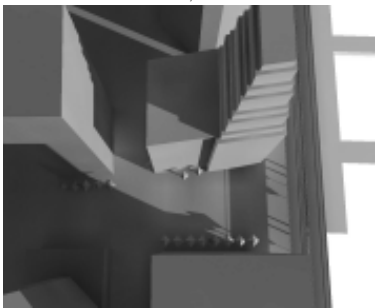

december 21, 12.00 p.m.

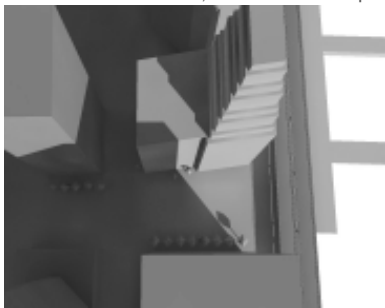

december 21, 16.00 p.m.

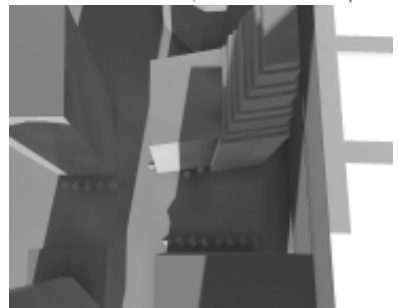

the study for the summer conditions clarified that the street and the site, which is located at the point where it opens to east river, are filled with light during the morning hours as the street is oriented 10 degrees north of due east. the short shadows of buildings cover the street up to its central axis for most of the day. in the winter months, the street and the site are fairly obscured by the long shadows of the tall and massive buildings from noon to the late afternoon.

june 21, 10.00 a.m.

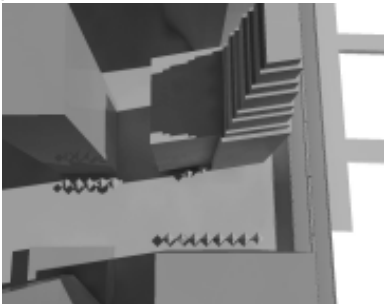

june 21, 12.00 p.m.

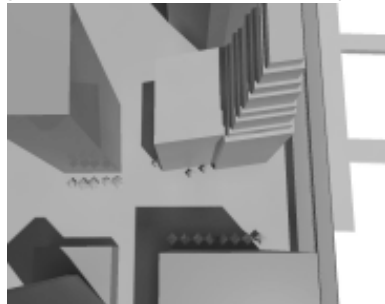

june 21, 16.00 p.m.

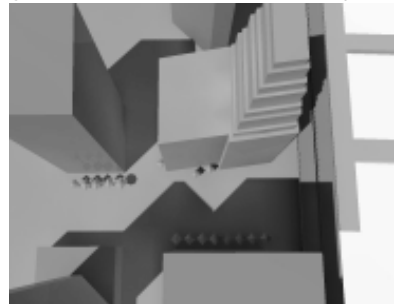

## c r y s t a l l i n e

'...cloudy translucence and the faint, dreamlike glow that suffuses it, as if it had drunk into its very depths the light of sun...'<sup>9</sup>

The project evolves around the challenges of the site. The particular setting makes the 'place' for the artifact to be.

Unlike the massive, stone-clad buildings with punched windows and tapering forms, the proposed building endeavors to be, in contrast with its neighbors, a glowing object, a jewel set among these boxes. The crystal-like building is characterized by its transparent envelope and the translucent, yet luminous folded ribbon walls forming the front skin.

"...layers of transparent and translucent materials, alternately obscured and revealed a sequence of views"<sup>10</sup>



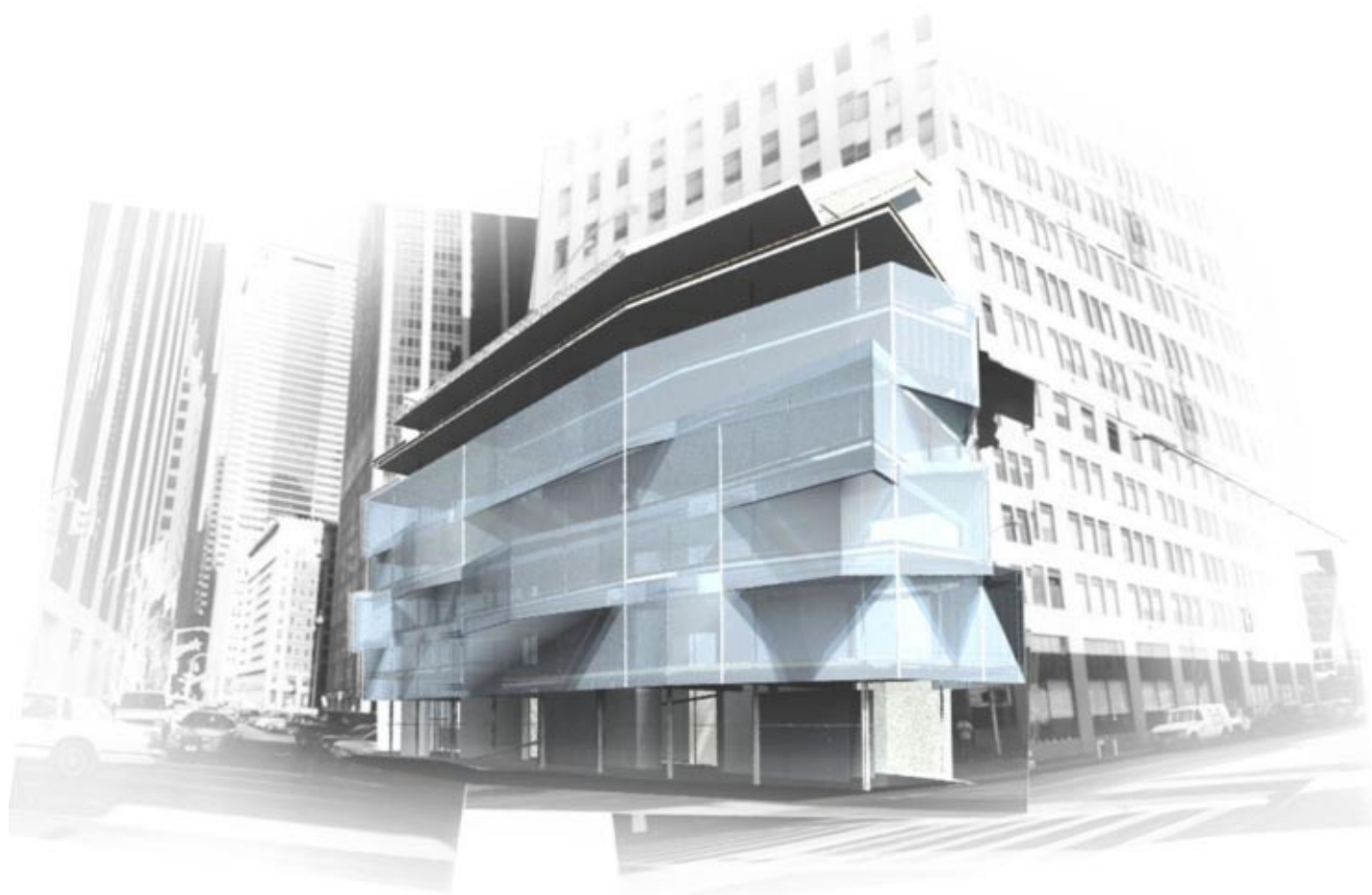

architecture in its most basic form, could arguably be...

...interpreted as a continuous assemblage of walls." 11



layers of wall

+ program

... spatial diagram

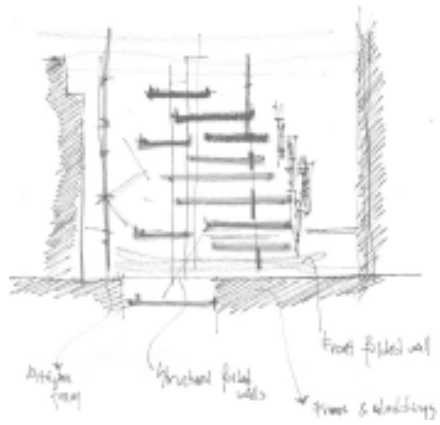
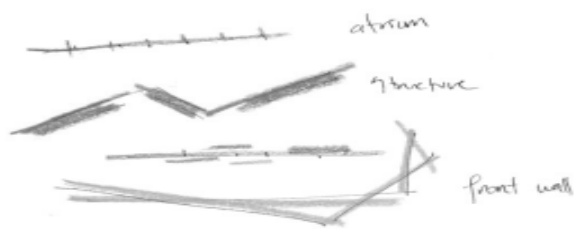

# l a y e r s o f t h e w a l l

"...before i built a wall, I would ask to know... what I was walling in or walling out..."<sup>10</sup>

the particular nature of **wall** in the realm of architecture is the threshold between inside and outside, secure and insecure, open and closed, welcoming and rejecting. it underlines the dualities that may exist on the two sides of itself, tension and harmony demonstrated concertedly. the existence of a wall is preeminently based on this dynamic struggle between the sides. It constitutes the interface between the delimited and enveloped spaces. a wall can embody manifold qualities of architectural vocabulary in itself; **surface, depth, texture, mass, penetrability** are a few of these layers of complexity. even a single wall with a single opening could have multiple layers and depth within itself. the openings or windows on one single plane can define the space flowing through one into another, from inside to outside, thus the views from the openings become backdrops and delay the perception of the space as one entity at once. **layering, overlapping and shifting** wall planes may further enhance the 3-dimensional complexity. delimiting and defining space, engaging or interrupting a path, framing or obscuring a view, each of the wall planes takes on distinct characteristics responding to these divers responsibilities. the complexity inherent in the edifice 'wall' is further promoted as it accommodates utilities. the wall not only serves as the structure and as the envelope, but also as the space itself to be inhabited. from the thick, massive wall of former ages, as being the element integrating all of these functions into one unified entity, to the intelligent facades of our century, the 'wall' transformed in its response to the demands of man and offerings of technology. this emphasis of architectural practice on the limits and potentials residing in the comfort conditions of human life, opens up new alleys to explore the complex interrelations between these characteristics of the wall and to articulate each of them in distinct layers through employing diverse materials, fabrication methods and technologies for the best performance regarding the particular objective of each characteristic. the space created **in-between** these layers becomes the extended threshold and transforms the conception of a wall in the architectural discourse from a single plane to a series of planes overlaid, as a piling up of manifold materials and techniques. "... architecture, like all contemporary garments, is technological, it controls the exchange of warmth between the interior and the exterior; it allows air through, it selects rays of light..."<sup>12</sup>

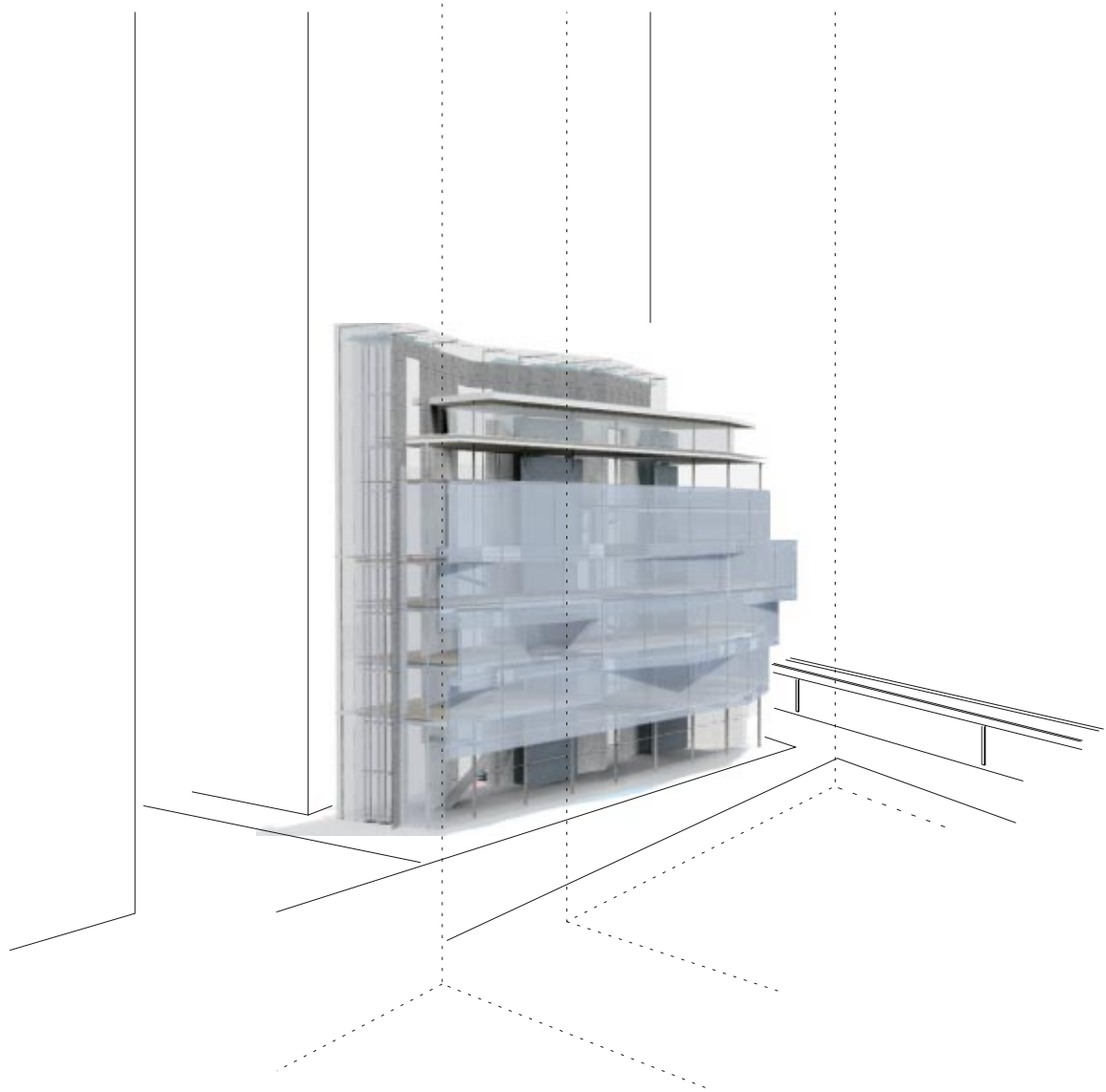

## a s s e m b l y   o f   t h e   l a y e r s

the project unfolds as an exploration of these distinct attributes of the wall itself, articulating its diverse functions, individually. the building can be perceived as a **thick wall** disassembled into its various elements. Each of the five fundamental elements of the design is articulated to address particular considerations regarding the tangible and intangible attributes such as site, access and control of light, structural firmness and clarity, penetrability, circulation and interaction with neighboring buildings. these five elements concurrently create the **space**. the spatial experience **inbetween** these elements transforms from one end of the building into the other end as one crosses its entire depth. with every step of movement, one feels the skin, touches the spine of the building and inhabits the structure.



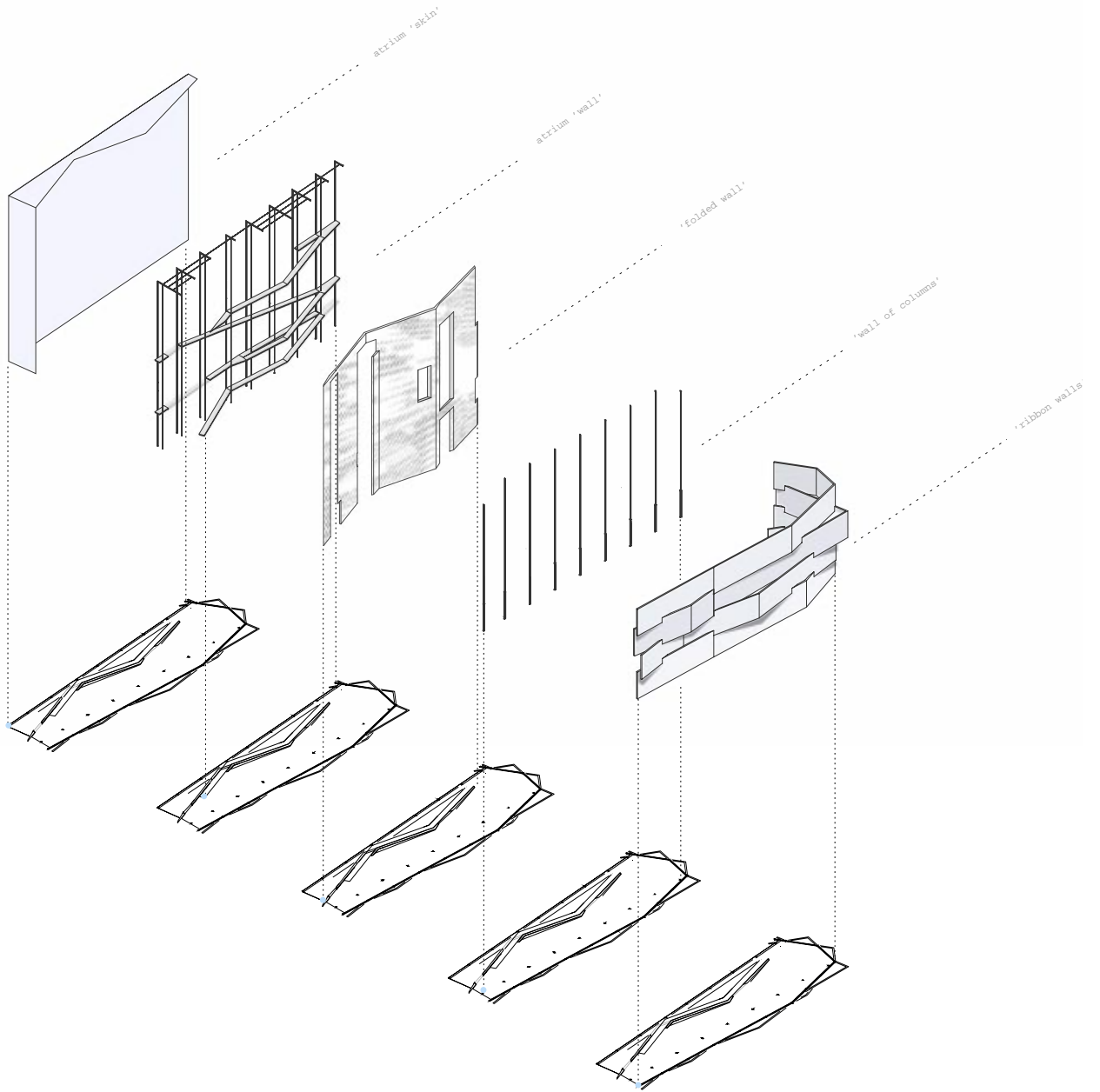

l a y e r s   o f   t h e   w a l l

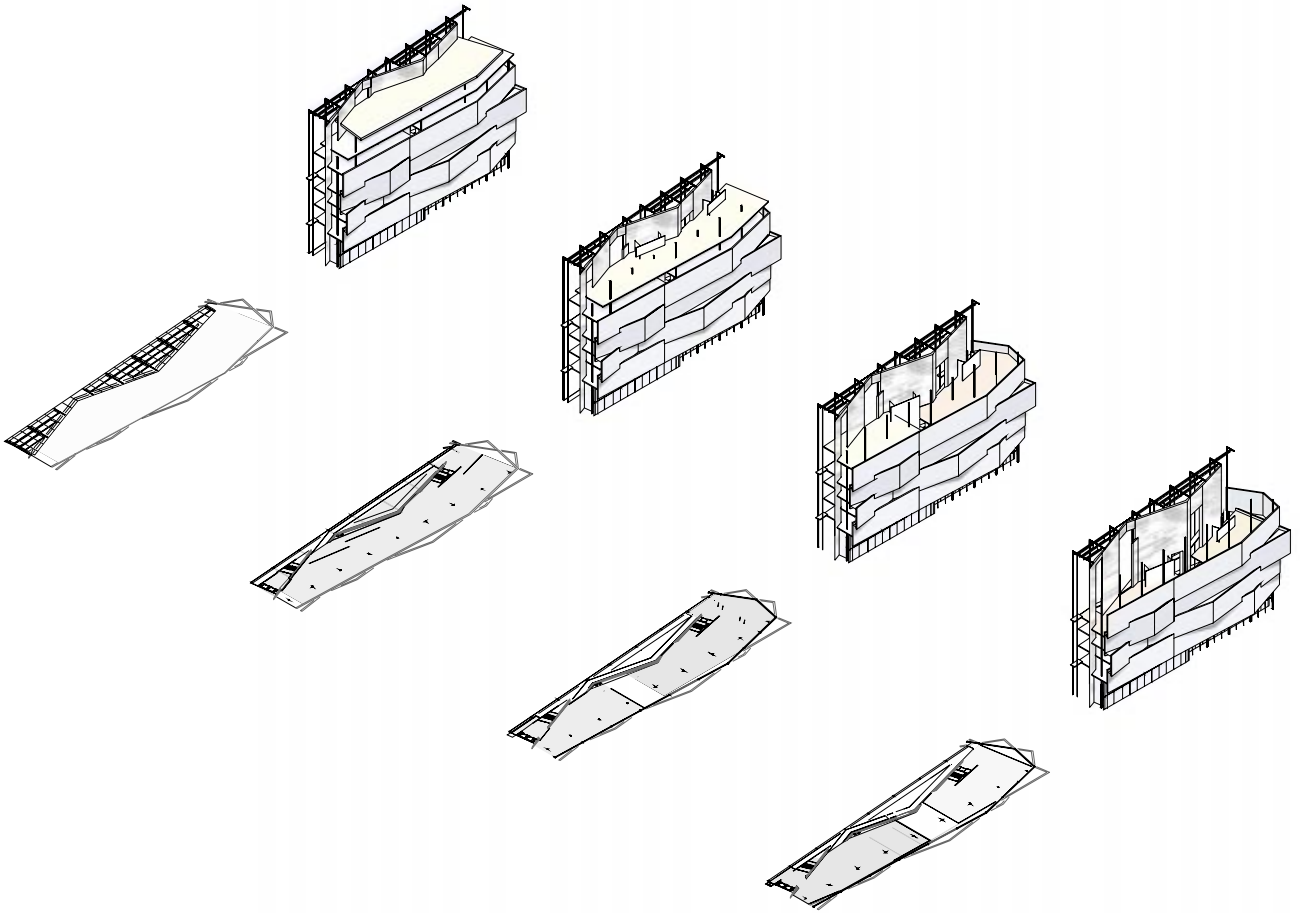

spatial diagram: program + layers of the wall

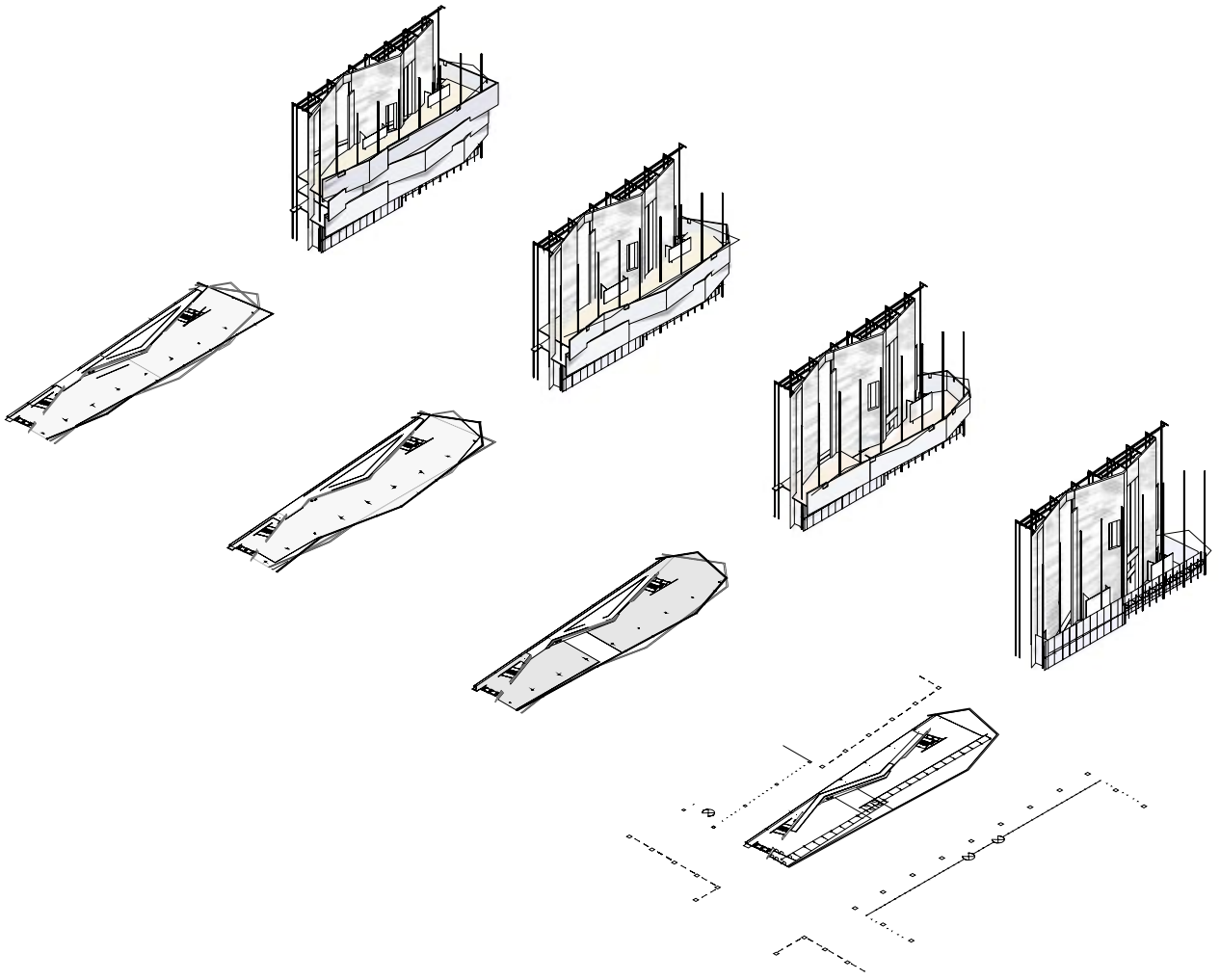



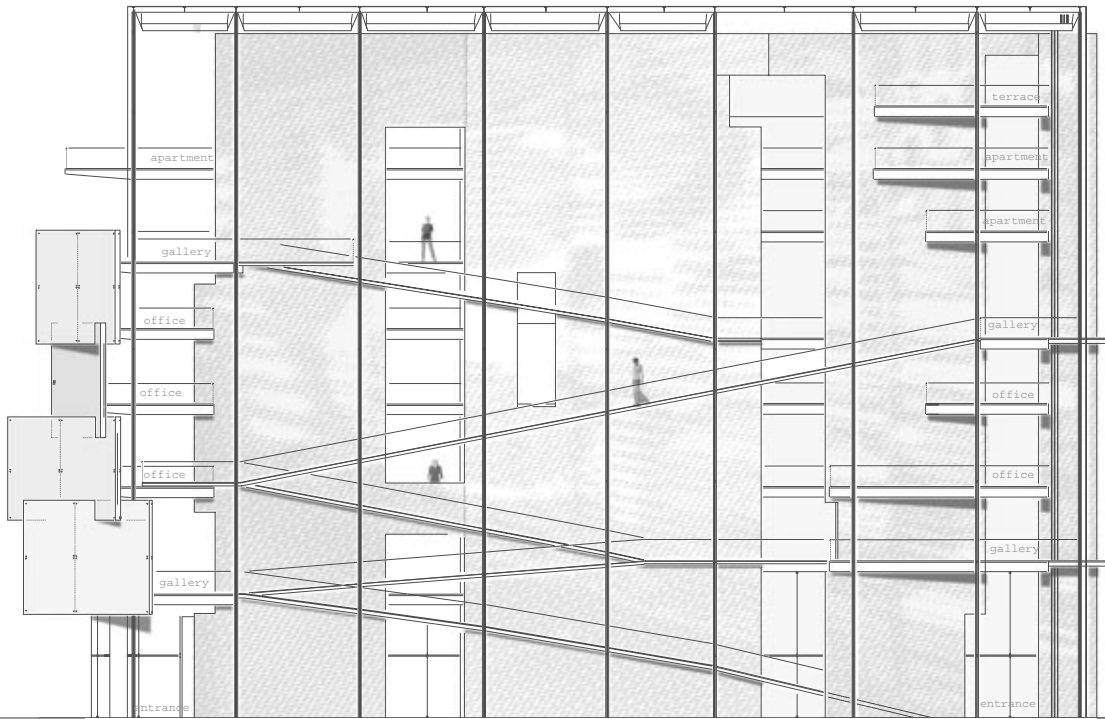

h street south street

st river east river east river east

wall street wall

1

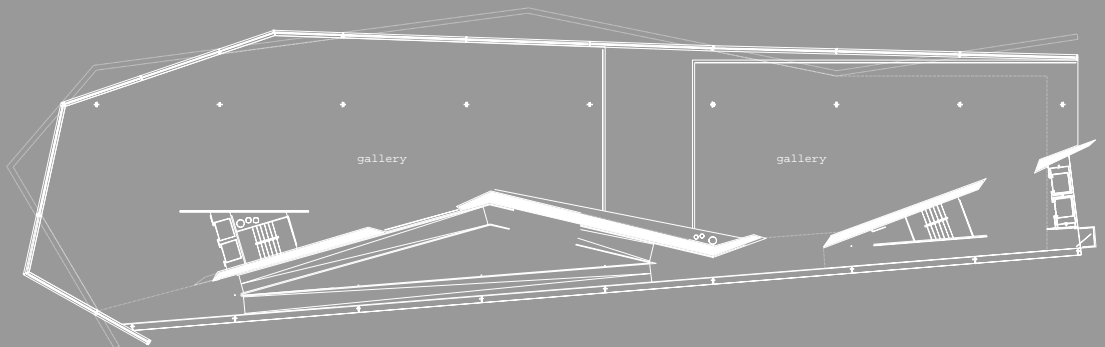



existing existing

existing existing

existing existing

existing existing

existing existing

existing existing

existing existing

existing existing

existing existing

existing existing

existing existing

existing existing

existing existing

existing existing

existing existing

existing existing

existing existing

existing existing

existing existing

existing existing

existing existing

existing existing

existing existing

existing existing

existing existing

existing existing

existing existing

existing existing

existing existing

existing existing

existing existing

existing existing

existing existing

existing existing

existing existing

existing existing

existing existing

existing existing

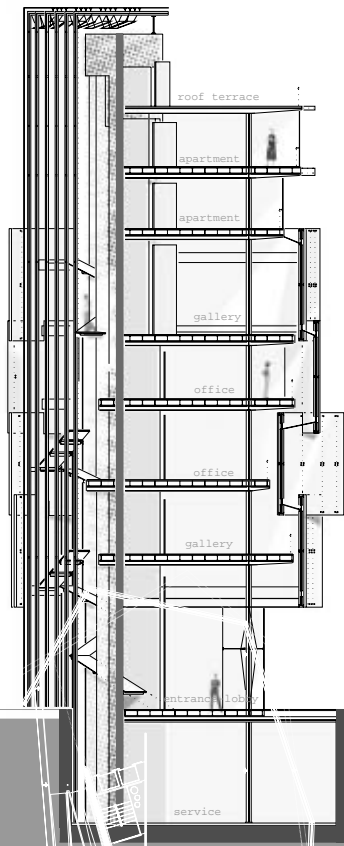

3

wall street wall street wall street

entrance lobby

service

lobby

0.2

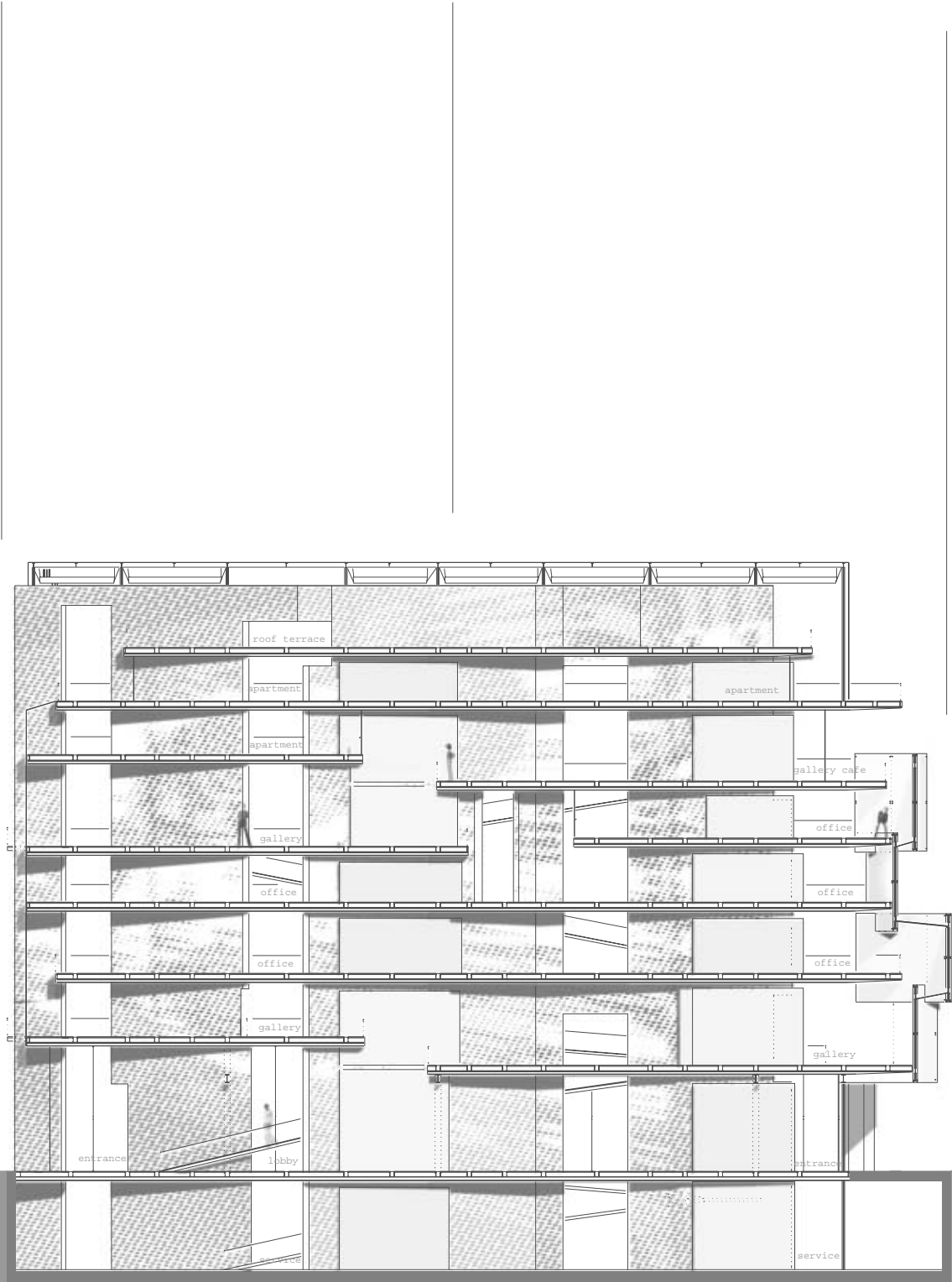

street wall street wall

south

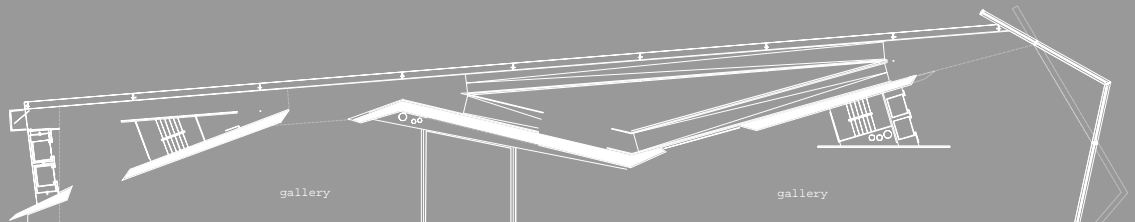





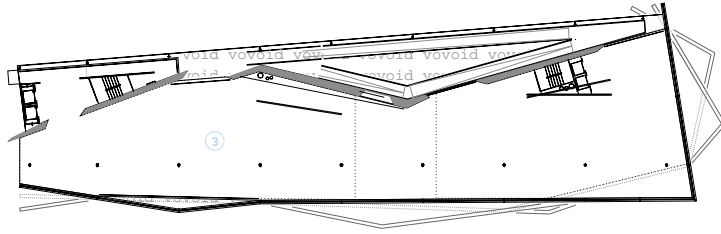

forth floor

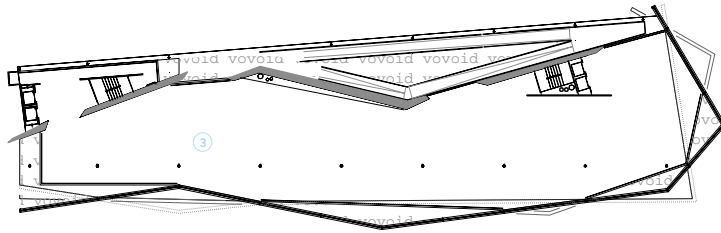

third floor

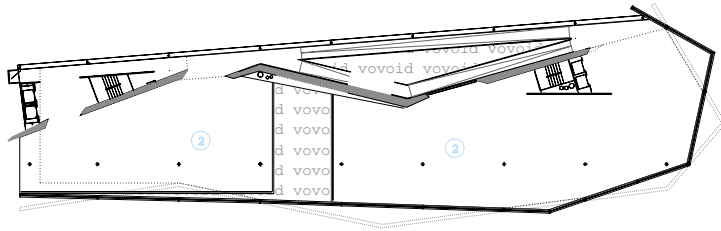

second floor

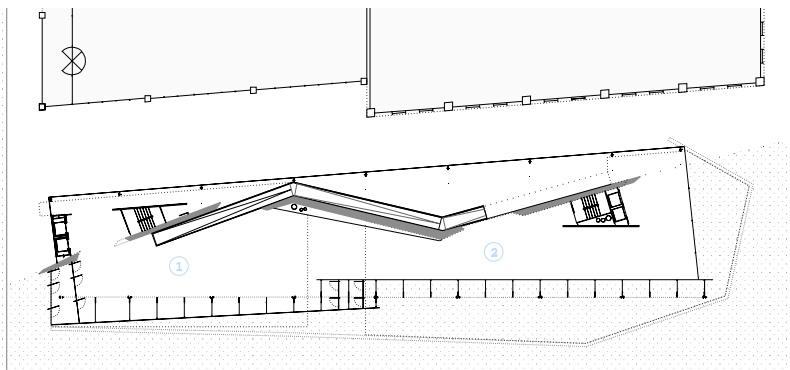
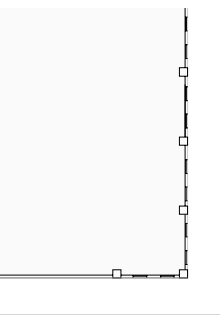

w a l l s t r e e t

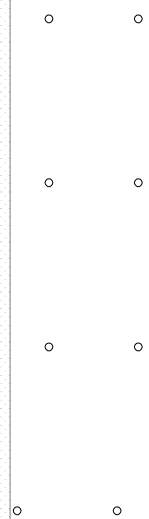
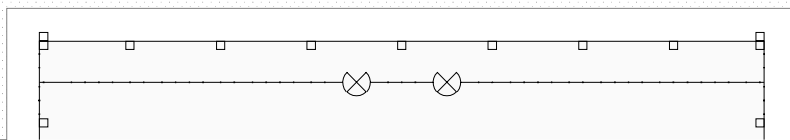
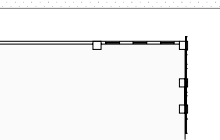

east river

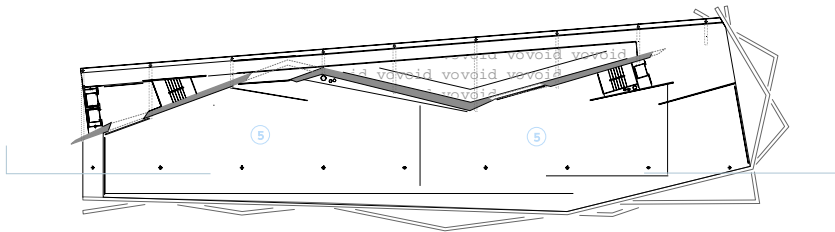

fifth floor

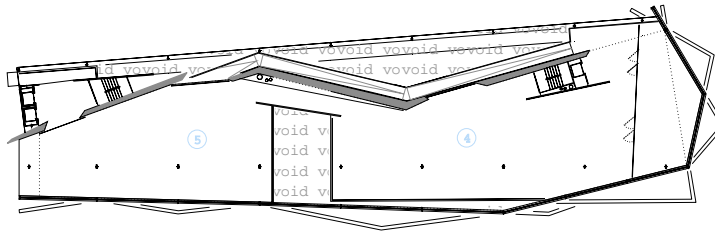

sixth floor

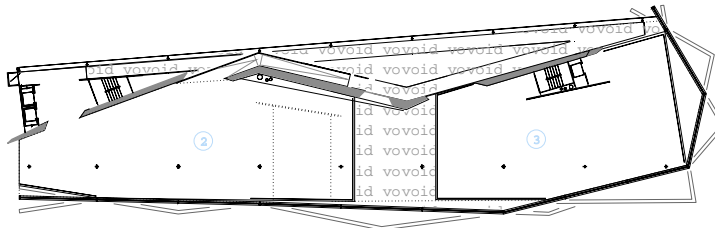

seventh floor

- ① entrance - lobby
- ② gallery
- ③ office
- ④ gallery cafe
- ⑤ apartment

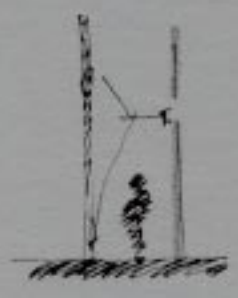
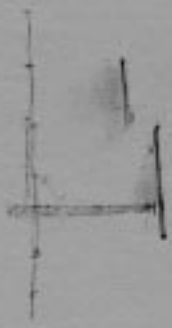

... what is exactly a wall ? ... 13



ribbon wall

folded wall

atrium wall

wall of columns

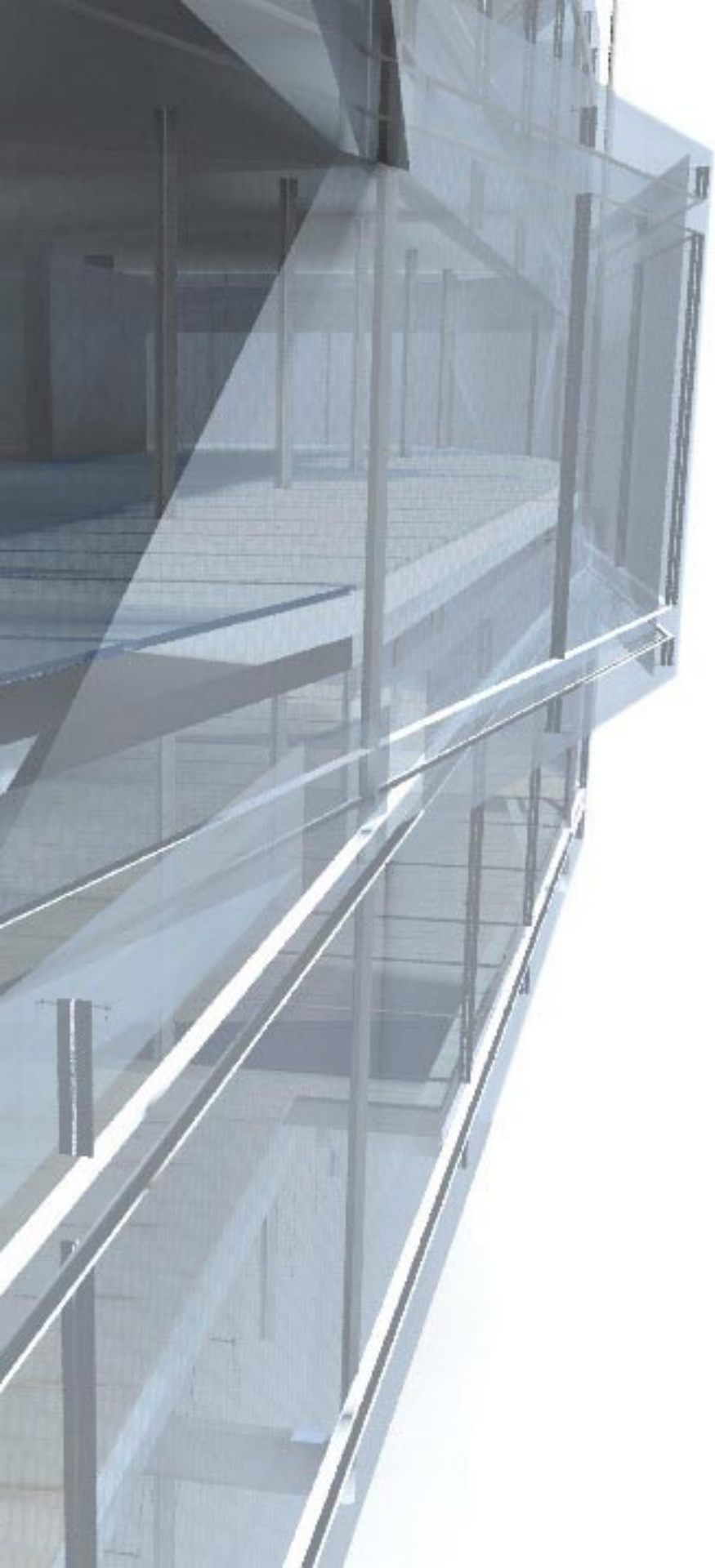



# r i b b o n w a l l s

"... disembodied glowing shapes loom up, their shadows never quite touching, their bodies ghosted and hovering... the fascinating shift of emphasis from solid object to dematerialized silhouette, from visibility to intimation..." 14

the folded, luminous front skin responds to the forces implied by the 'site'. it unfolds as an urban gesture. it becomes the ambient object in a setting characterized by an image of heaviness, closeness and isolation. the **façade** becomes a **veil** and distances the viewer from the spaces and the faint images of forms within as well as the viewer inside from the outside world. however, the veil does not obstruct the continuity of perception. the seamless, undulating face screens the interior against the elevated highway, veils the building during the day and glows through the 'cracks' at night. the superimpositions provided by accidental reflections of light, playing upon the translucent surface, generate the **slowing of light**; they delay the visual perception of the interior. the interior reveals glimpses of itself when it is lit. it hints that the ribbon **skin** is the prime generator of the building **form**. the natural light is transformed with the positioning and layering of the ribbons of the façade. the proposed lighting situations and the limits of the structural system assert the unique positions and dimensions of the overlaps and cracks. the facade expands through the skin and is interwoven with the interior spaces. you can stand inbetween two overlapping ribbon walls, where you are both inside and outside of the facade. the boundary between the interior of the building and the urban fabric dissolves.

"... we feel how the building absorbs the daylight, the position of the sun and the points of the compass, and we are aware of the modulations of light caused by the invisible, yet perceptible outside environment..." 15



alternatives for dialogue  
between ribbon walls



alternatives for dialogue between  
ribbon wall structure + skin



dialogue between  
two ribbon walls

## s t a c k e d   v e r s u s   w o v e n

the galleries and the information media offices require special quality and control of light. the demand for **diffused** and **reflected** light rather than **direct light** led to the exploration of the front skin, mainly focusing on the interrelations of each ribbon wall to another. to maximize the amount of reflected light through the cracks, while controlling the amount of direct light, the single ribbon walls are shifted and overlapped. the dialogue between the individual ribbon walls is resolved through the analysis of the nature of the structure to provide the overlaps and the perception of the front skin. the stacked system emphasizes predominantly horizontals, whereas the woven system emphasizes a combination of verticals and horizontals; the stacked method is chosen to accentuate the singular band-like character of the ribbon walls. the skin of the ribbons extends beyond the dimensions of the structure to maximize the section for the reflection of light which is trapped inbetween the skins of two overlapped ribbon walls.

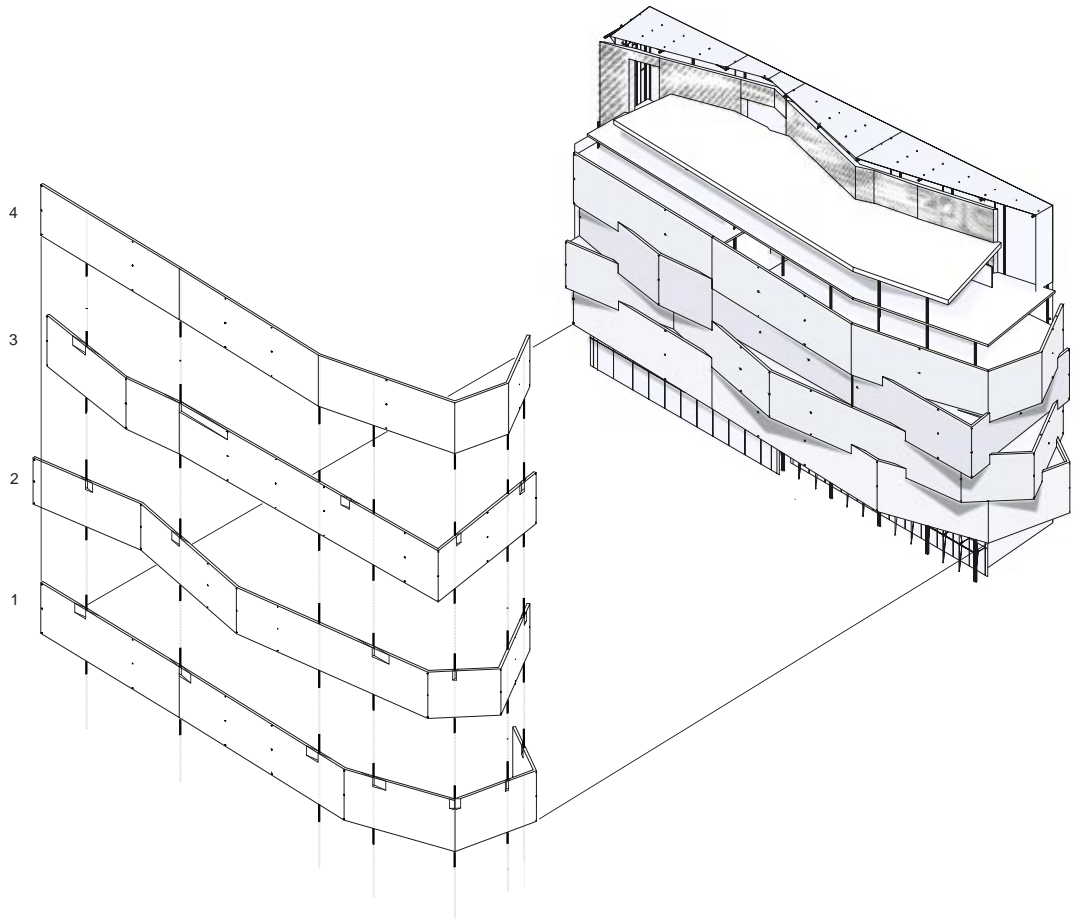

s t a c k e d   r i b b o n   w a l l s

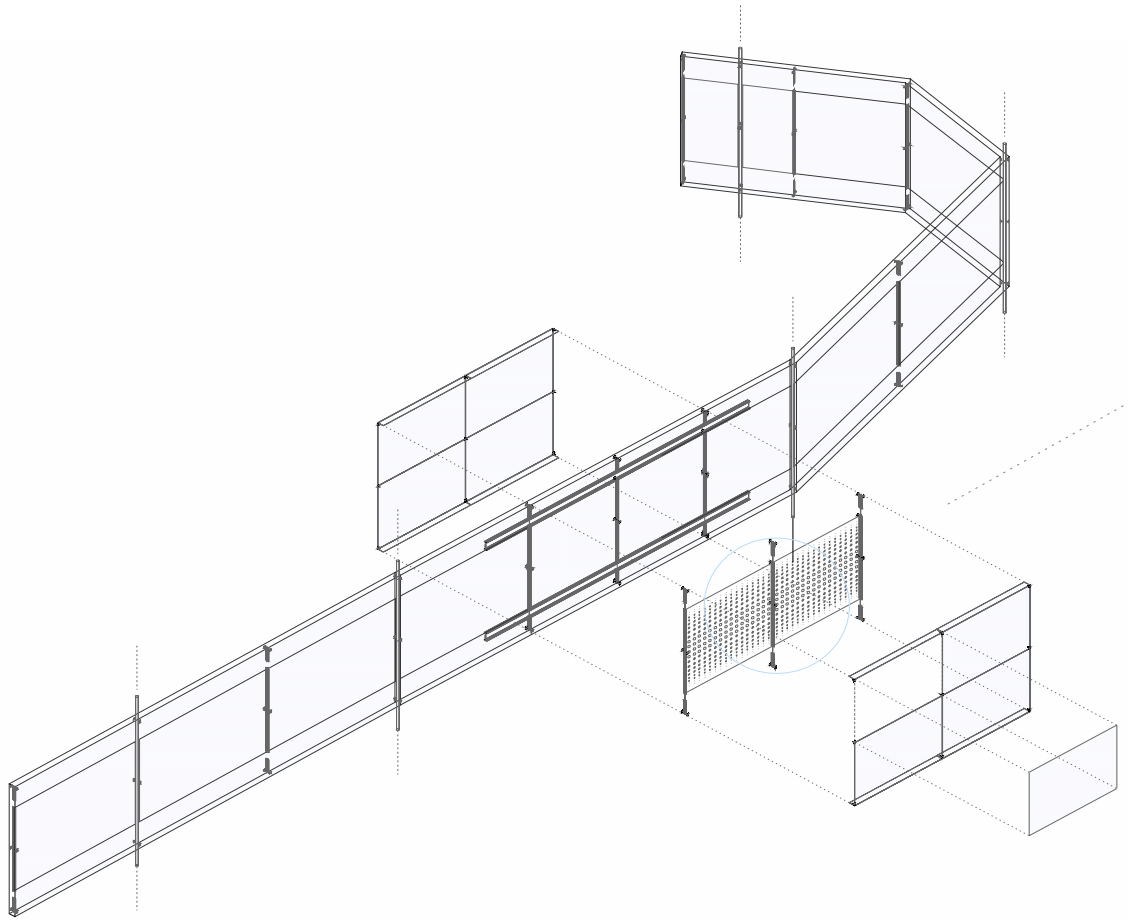

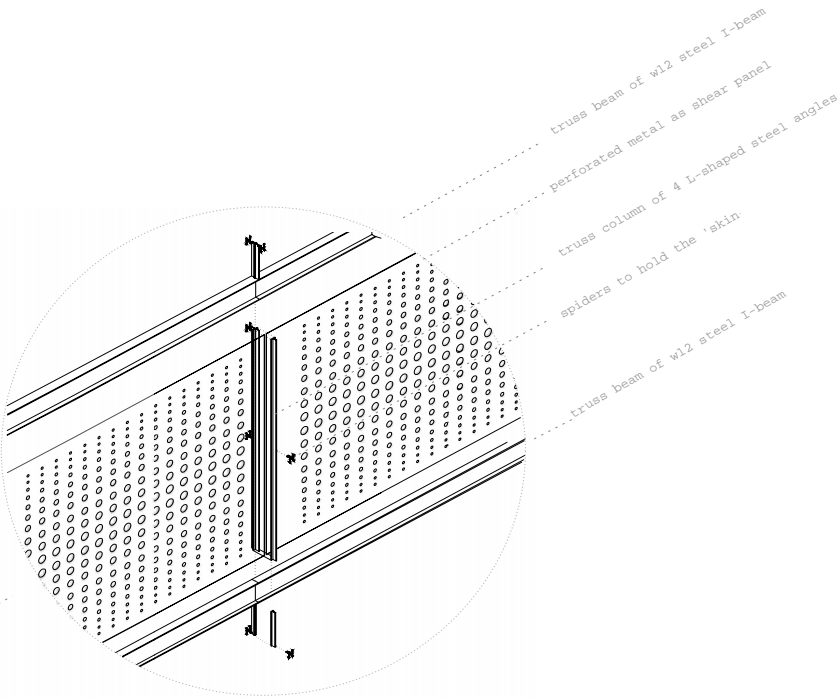

axonometric detail of single ribbon wall

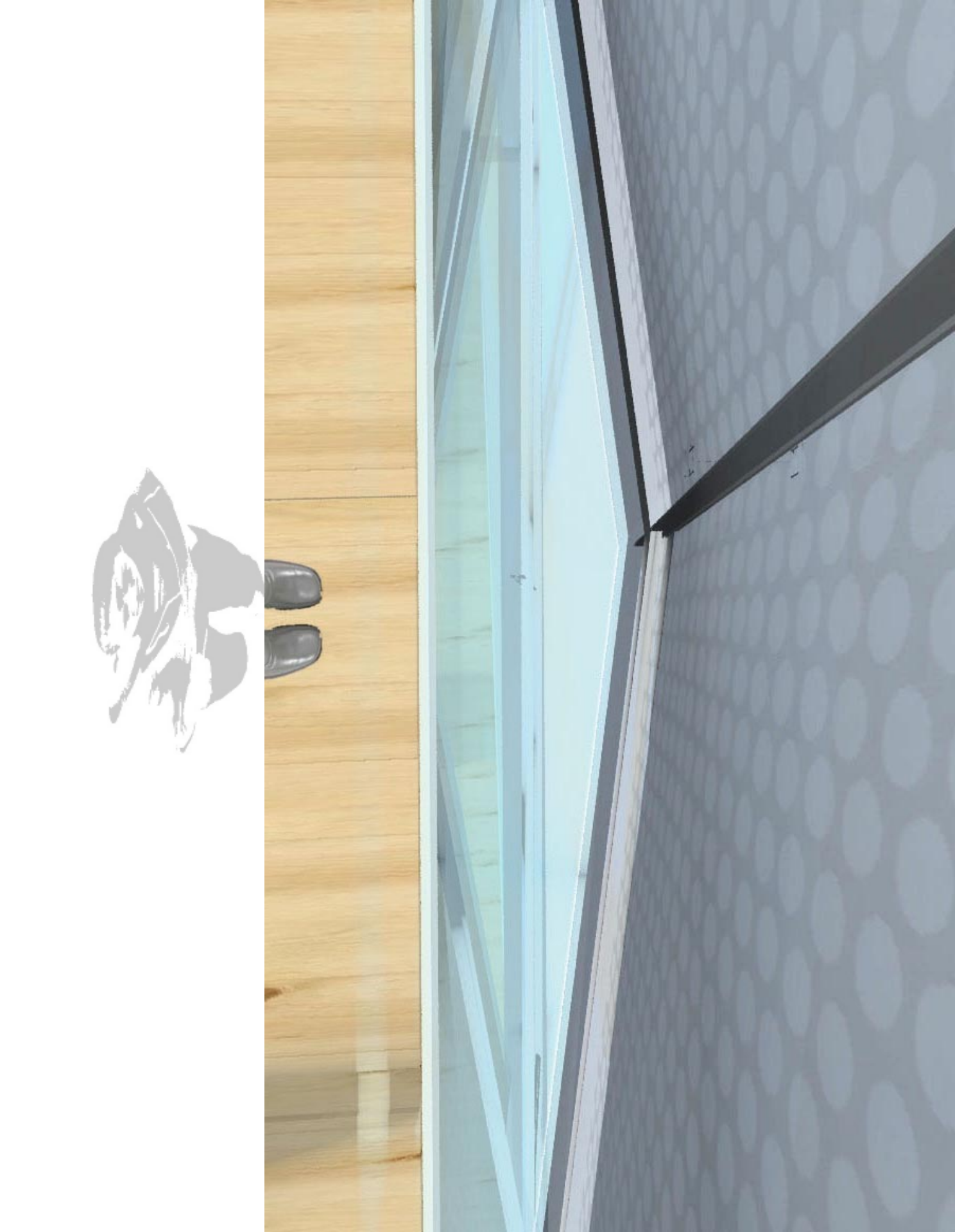

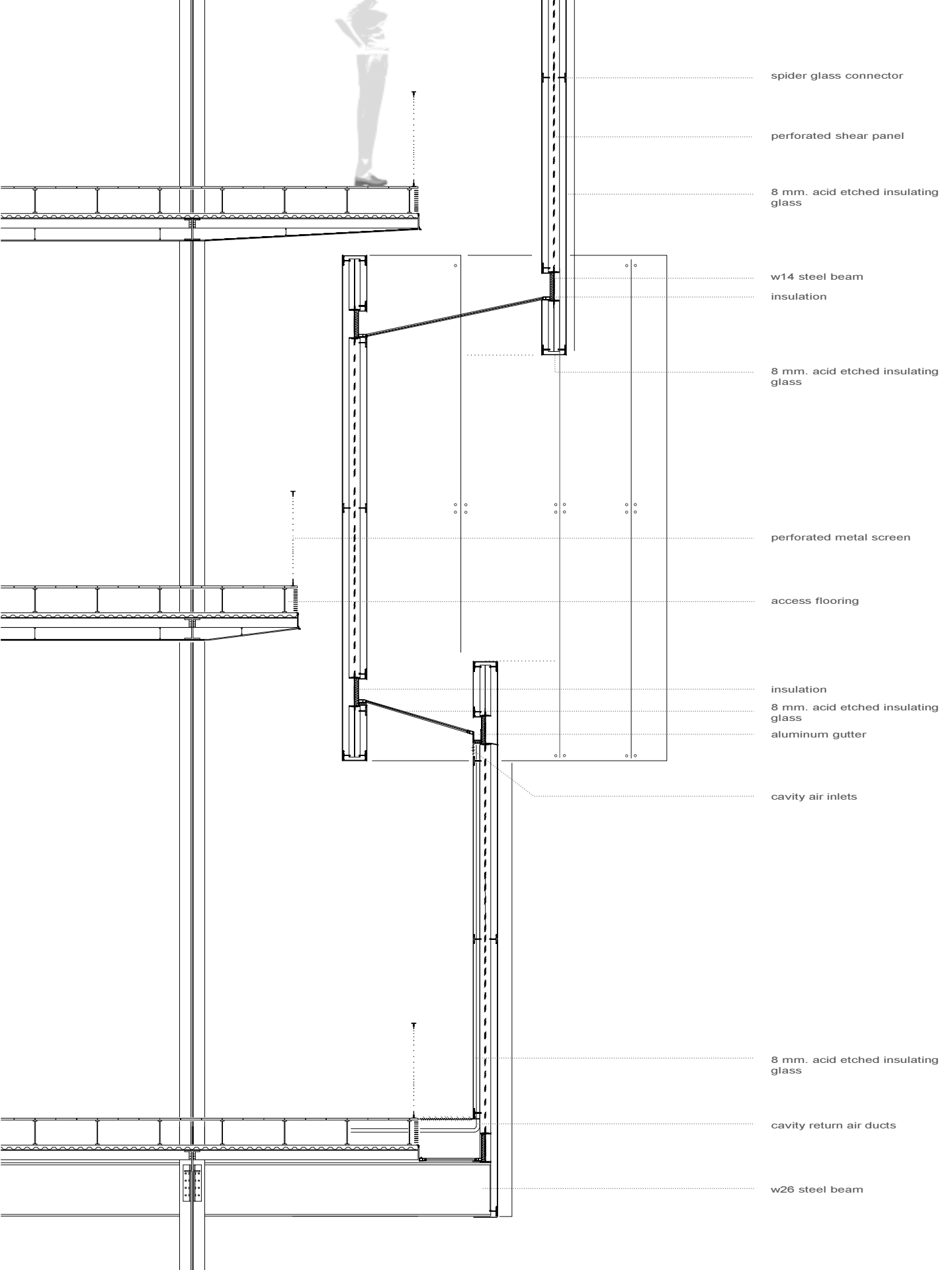

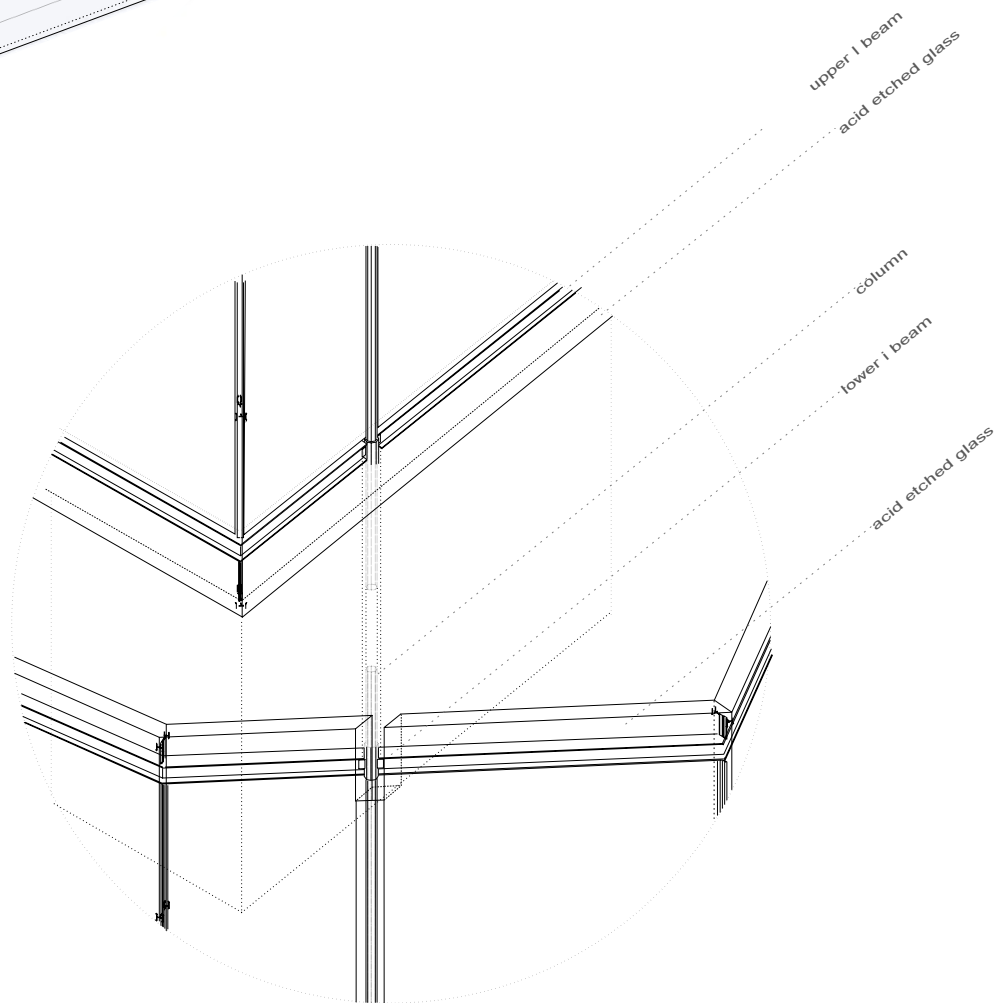
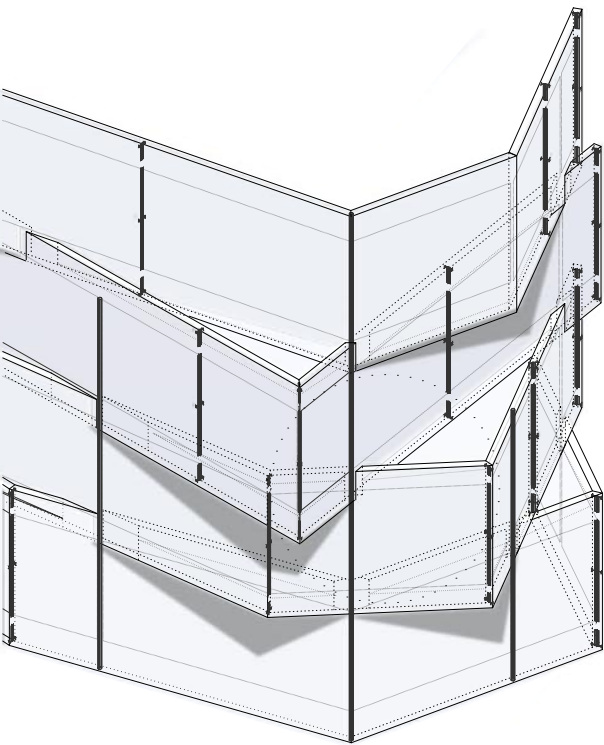



# j o i n t                    v e r s u s                    b r e a k

one of the most significant moments of discovery in this thesis is about **joint** and **break**. the continuous effort to develop refined detail, revealed the undeniable nature of an architectural joint, where two pieces confront each other at a point. the decision as an architect demands the awareness of the fact that it is not two hypothetical lines simply intersecting. recognizing the presence of each element and respecting their identities hint a resolution through prioritizing one over the other. in the case of the project, to provide the quality of reflected light into the inner spaces, the **ribbon walls** overlap, pierce and penetrate each other. the beams of the individual trusses forming the ribbon walls come up against each other at the points where they overlap. the mere translation of the design intention into constructional decisions results in I beams cut in acute angles depending on their positioning at the particular point. the search for the motive to favor one piece over another recalled the preceding decision about the structural assembly of the trusses. as the individual truss members are stacked on top of each other, they transfer loads down to the lower levels at the points where they 'overlap'. so the structural **hierarchy** hinted the resolution. the beams of the trusses are overlapped and the glass panes of the upper ribbon walls keep their **integrity** while the lower ones are interrupted to make the 'break' for the former to penetrate through. those points become the celebration of the refined overlap of design intention and constructional principles as a significant note in an architect's repertory.

"...I am alluding to that point at which things break against each other rather than connect; that significant fulcrum at which one system, surface or material abruptly ends to give way to another. meaning may be thus encoded through the interplay between 'joint' and 'break'and in this regard may have just as much meaning as connection..."<sup>16</sup>

1

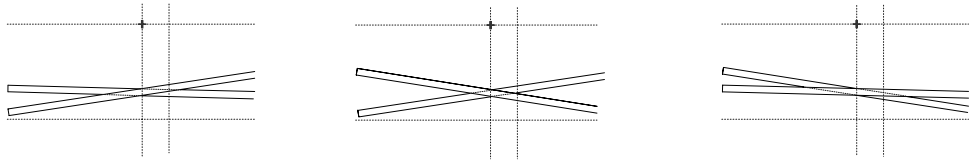

2

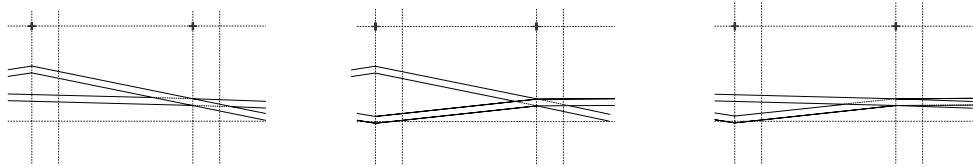

3

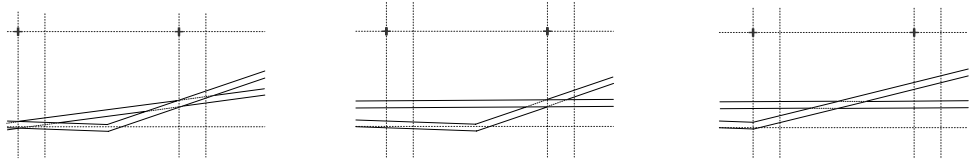

4

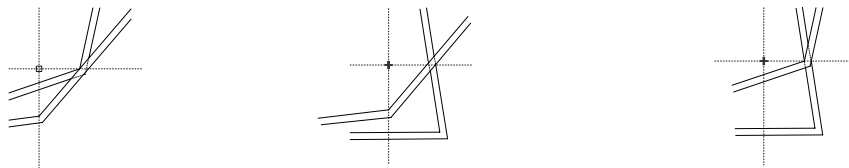

5

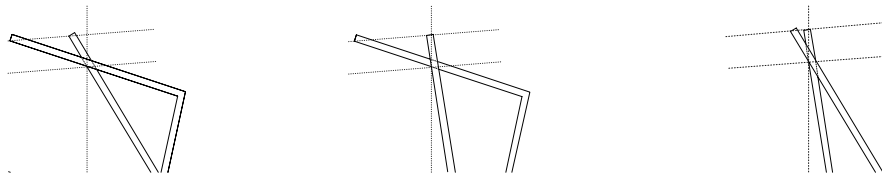



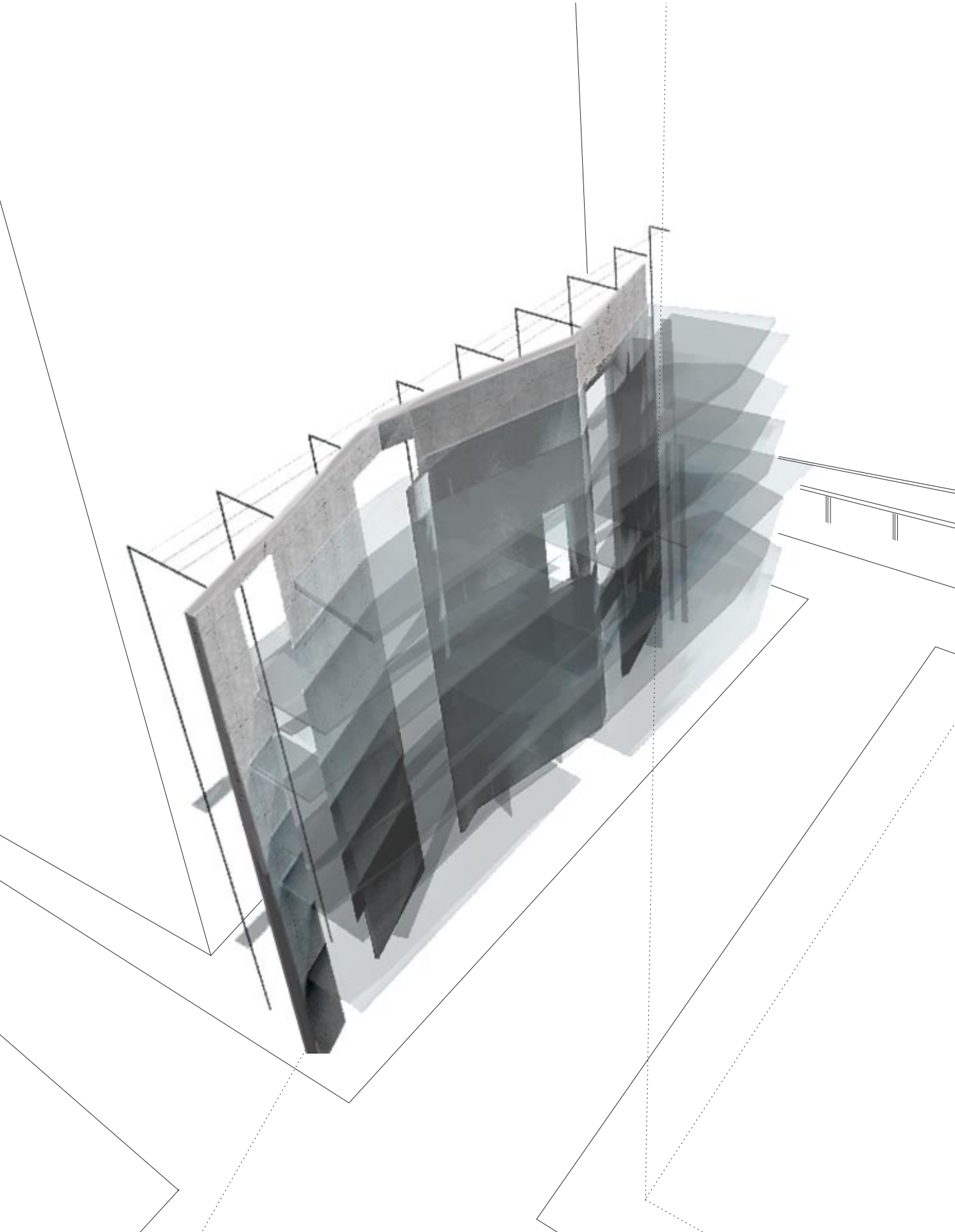

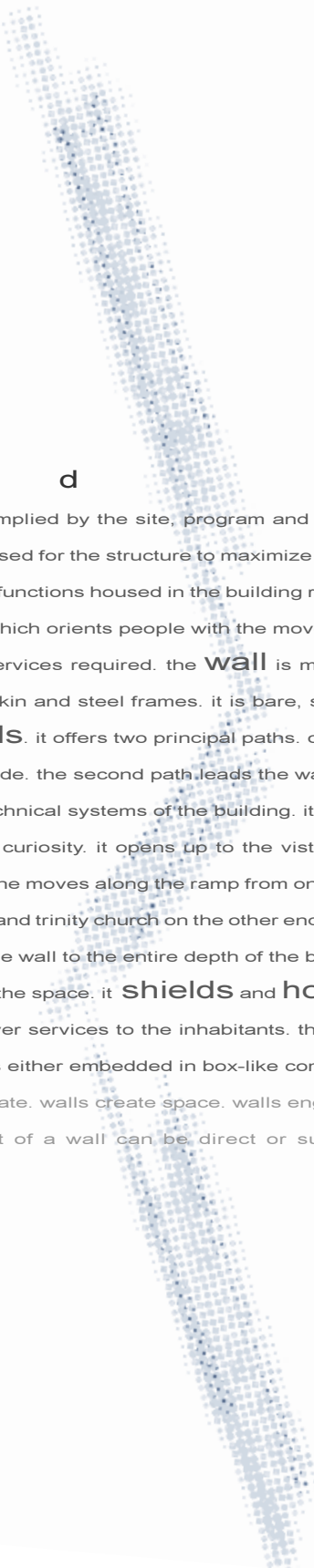

## f o l d e d w a l l

the wall evolves in response to the forces implied by the site, program and structure. the narrowness and the small scale of the site suggest the minimum area used for the structure to maximize the usable space. the prominent location of the site offers views and vistas; the diverse functions housed in the building require services. to address these issues, the wall is sculptured as a concrete plane, which orients people with the moves of the fold, opens up to views with the interruptions of the folds and houses the services required. the **wall** is monolithic, almost sculptural. it is thick in contrary to the almost dimensionless front skin and steel frames. it is bare, site cast concrete, with no clad or added layers. it acquires its strength from the **folds**. it offers two principal paths. one leads people from wall street into the building and directs them towards the riverside. the second path leads the way to the gallery café and the apartments on the upper floors. it bears all floors and technical systems of the building. it leads the flow of dynamic spatial experience along itself and intensifies the spatial curiosity. it opens up to the vistas of the site through **breaks** in the otherwise continuous order of the folds. as one moves along the ramp from one floor to another, one is offered views of the brooklyn bridge and riverside at one end and trinity church on the other end. at these moments of fracture, the space expands from one side to the other side of the wall to the entire depth of the building, from office to atrium, from atrium to gallery. the wall delimits, yet **weaves** the space. it **shields** and **houses** the vertical paths along with the mechanical and electrical systems that deliver services to the inhabitants. the emergency stairs, elevators and other mechanical systems are a part of the wall as either embedded in box-like composition or between an expanded layer. "... walls define the limits of what they separate. walls create space. walls engaging or adjacent to a path can suggest or force a change of direction. the effect of a wall can be direct or subtle, physical or purely implied..." 17

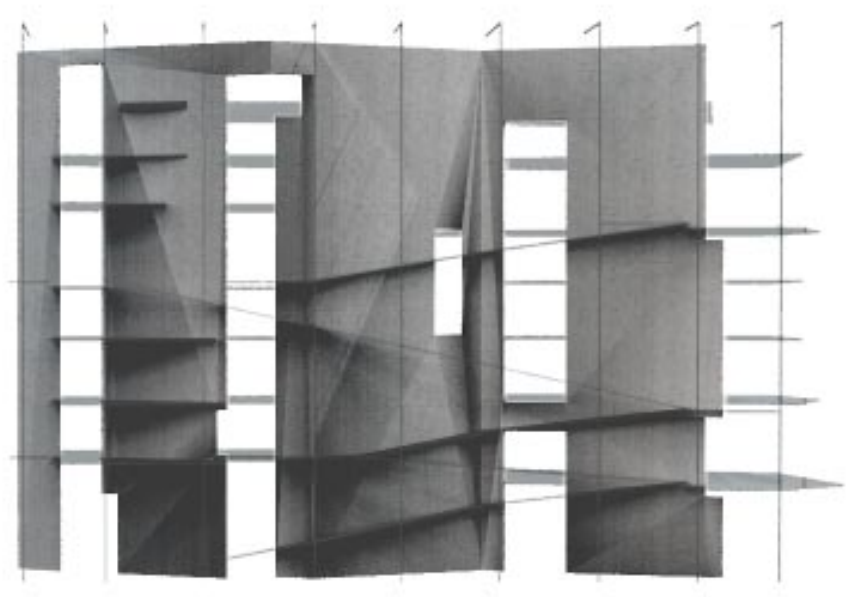
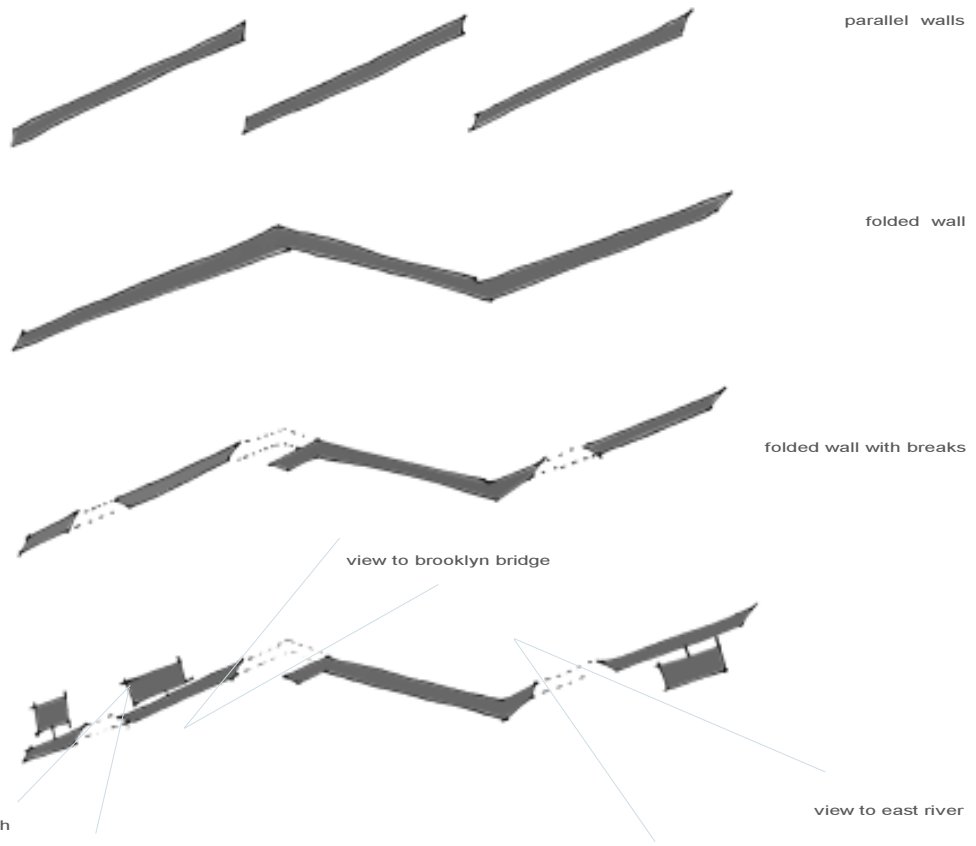

evolution of the folded wall

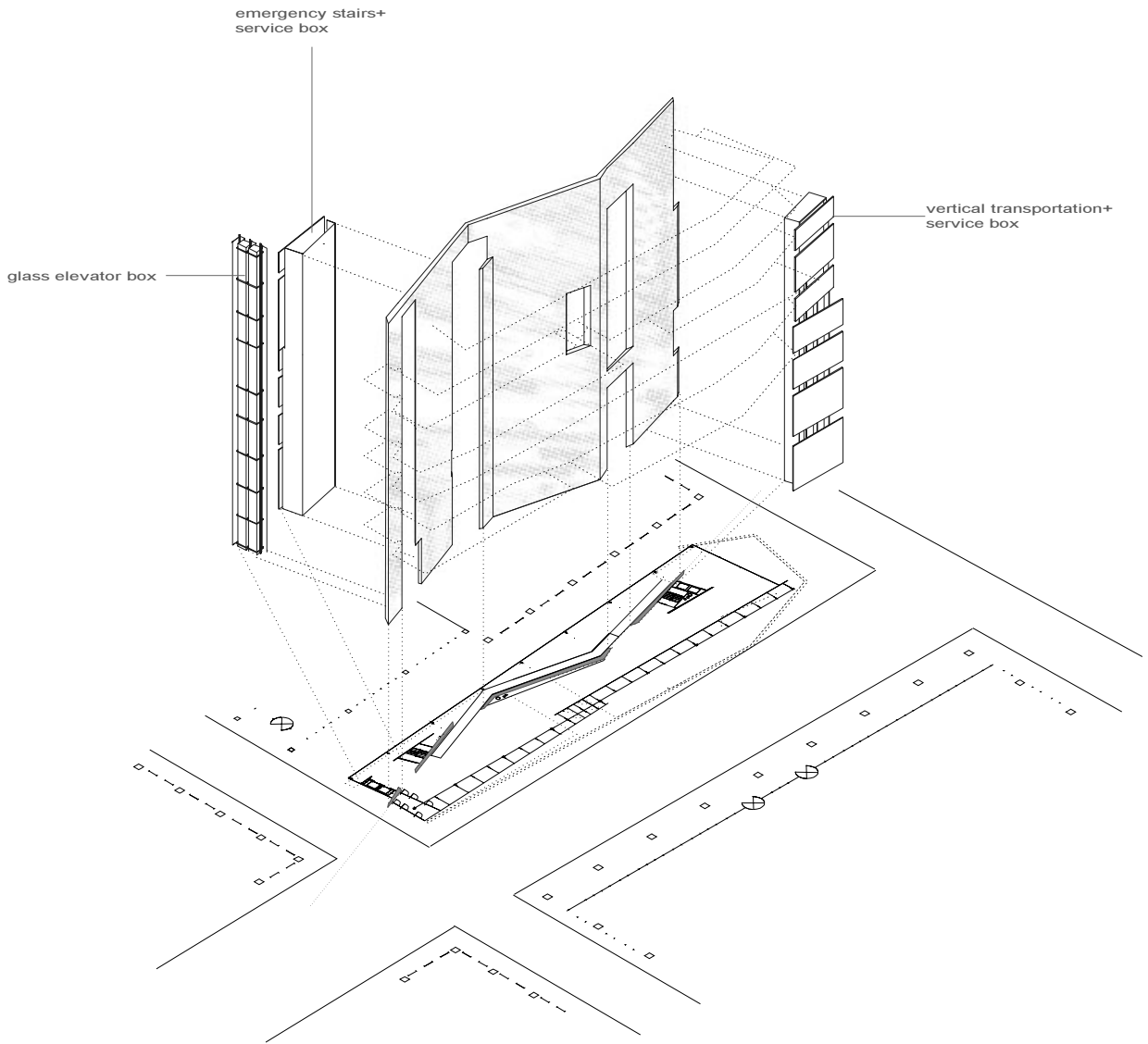

f o l d e d   w a l l   a n d   s e r v i c e   b o x e s





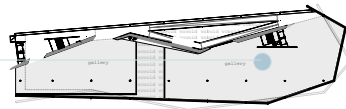

... translucency versus transparency, dark versus light, delimited versus open... the **dualities** inherent in two sides of a wall with respect to the spatial conditions such as proportions, materiality and access to light are articulated on either side of the folded wall. the offices and the galleries located on the southeast side of the wall are characterized by diffused light provided by the translucent ribbon walls. they are confined with the ghosted silhouette of the scenery. the views are restricted towards trinity church at the tail of the building and towards the neighboring skyscraper at moments of break of the folded wall. they have limited expansion towards the sky and the street life through the cracks.

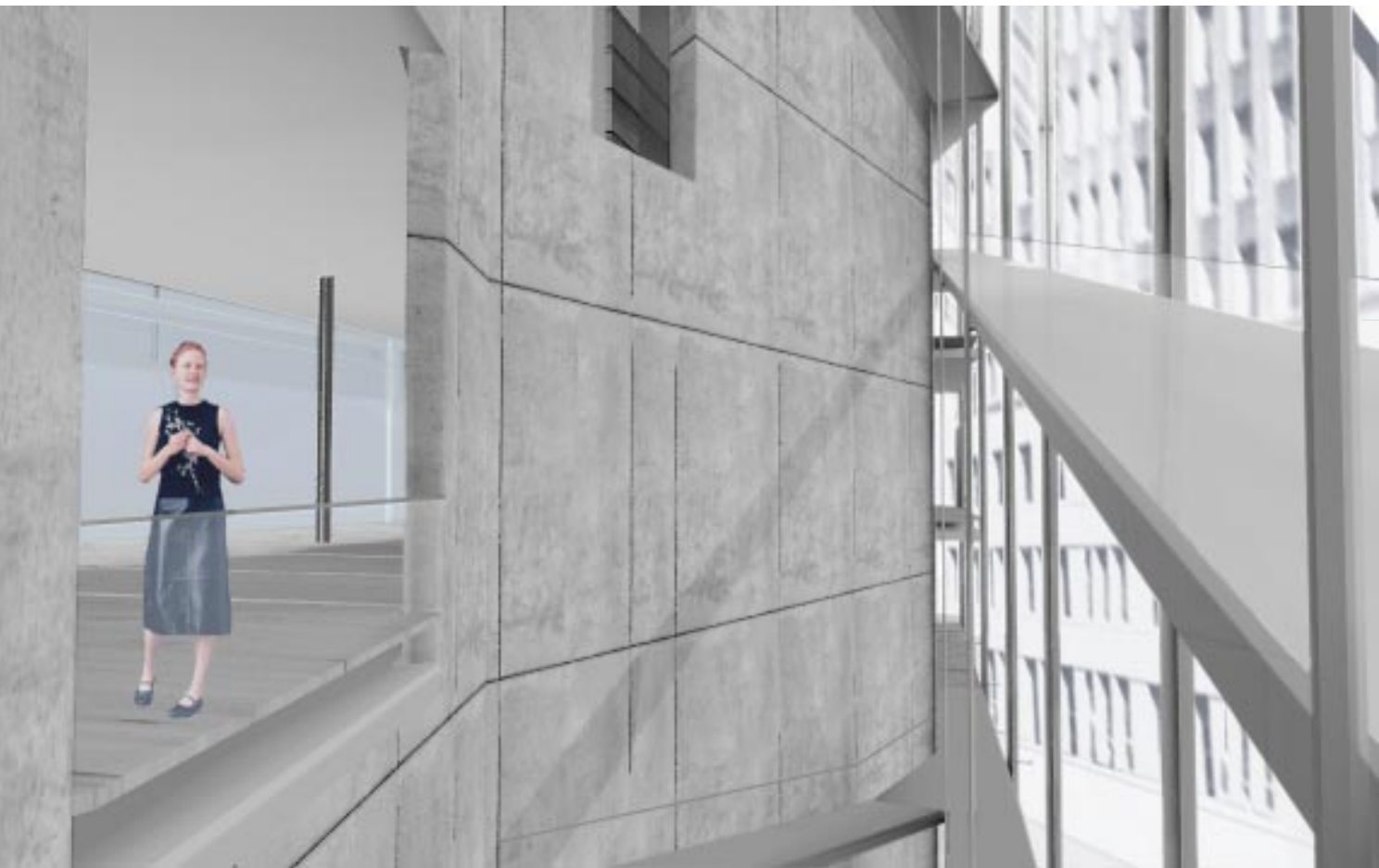

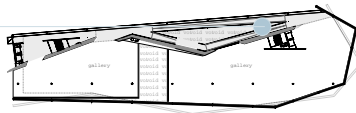

the atrium side of the folded wall is filled with light captured by the transparent atrium skin. the dimensions of space in-between the folded wall and the atrium wall are generous particularly in a vertical sense. the space also extends horizontally towards the interior spaces on the other side of the wall through the breaks, while it contracts at other points where one can touch the corners of the folds. it is open to the views of the canyon, neighboring skyscraper and riverside with maximum transparency on the other side.

## a t r i u m w a l l

the close proximity to the neighboring skyscraper and the challenge of bringing sunlight into the depths of the building in the particular setting on wall street influenced the design of the atrium wall. the **thinnest steel frame** structure and the **transparent glass skin** attached to it, provide natural daylight to the punched windows of the 1930's skyscraper and to the ramp, which is integral with the steel structure, as the space in-between the folded wall and the atrium wall is illuminated with northern light. the thin frame structure bends at the top and forms the roof of the atrium. the perforated metal screens hung from the roof facilitate the control of direct light in order to prevent glare. the light funneled inside the atrium is reflected back to the interior spaces on the other side of the folded wall at points of the break, by the reflective perforated panels attached to the atrium structure. they also perform as screens for the functions housed inside, as the density of the perforations provides the control of the visual connection between the spaces on either side of the transparent atrium skin. two of the boxes, which shield services and vertical transportation such as fire stairs and elevators, are also positioned in this in-between space, attached to the folded wall. the all-glass elevator, which is located at the northwest edge of the building, provides the uninterrupted view of the canyon and trinity church.

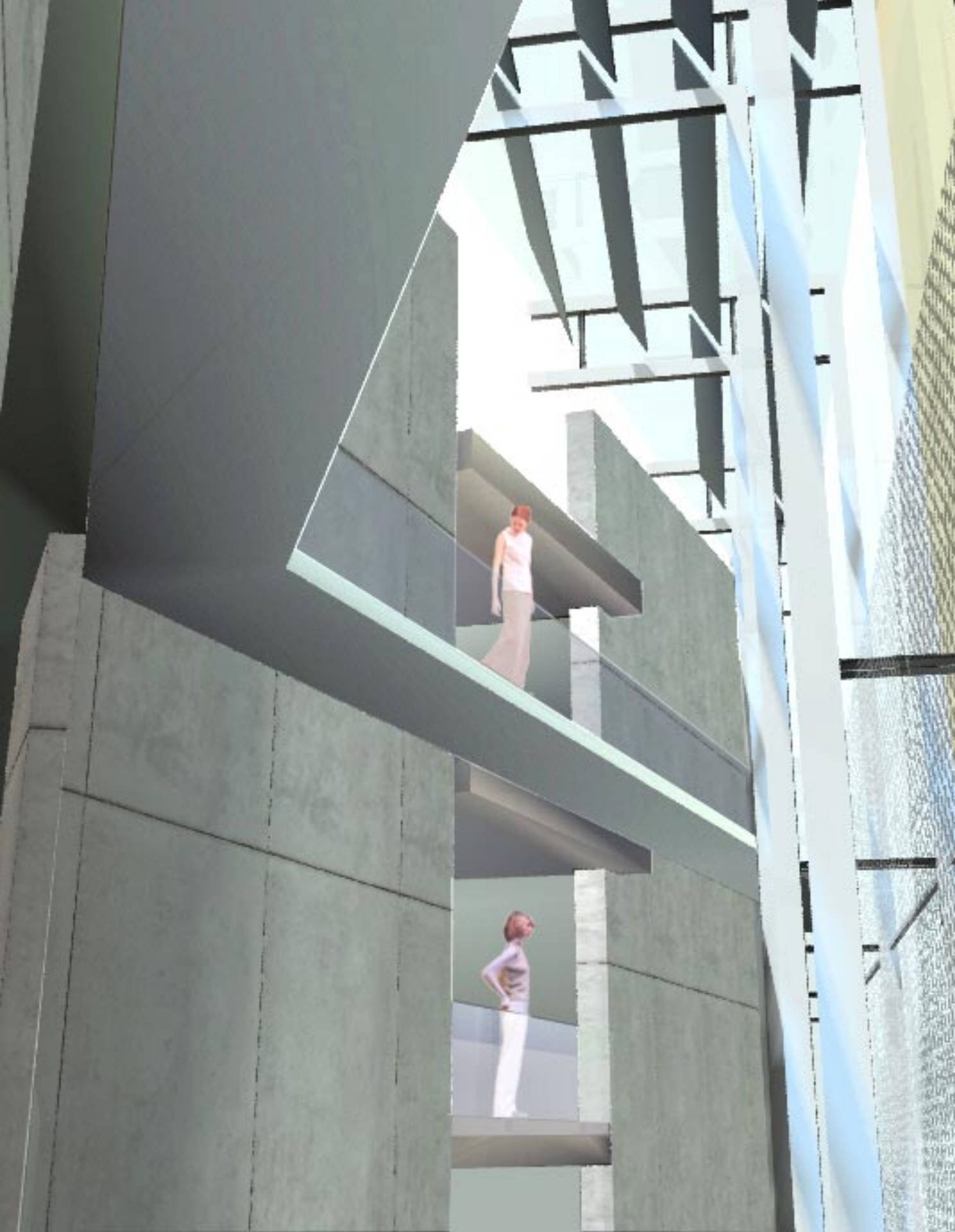

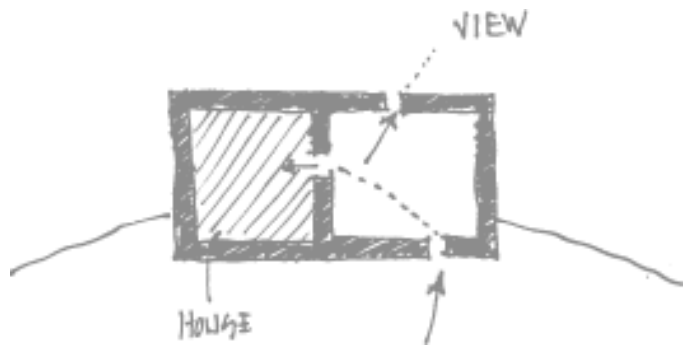

"...a buddhist monk lived high in the mountains, in a small stone house. far, far in the distance was the ocean, visible and beautiful from the mountains. but it was not visible from the monk's house itself, nor from the approach road to the house. however, in front of the house there stood a courtyard surrounded by a thick stone wall. as one came to the house, one passed through the gate into this court, and then diagonally across the court to the front door of the house. on the far side of the courtyard there was a slit in the wall, narrow and diagonal, cut through the thickness of the wall. as a person walked across the court, at one spot, where his position lined up with the slit in the wall, for an instant, he could see the ocean. and then he was past it once again, into the house... the view of the distant sea stays alive forever..."<sup>18</sup>



view from a traditional turkish street view from the ramp towards the gallery

**view** is a beautiful thing. one wants to enjoy it and drink it in everyday. but the more open it is, the more obvious, the more it shouts, the sooner it will fade. gradually it will become part of the building, like a wallpaper; and the intensity of its beauty will no longer be accessible to the people who live there... put the windows which look onto the view at places of transition-along paths, in hallways, in entry ways, on stairs, between rooms... people will see a glimpse of the distant view as they come up to the window or pass it; but the view is never visible from the places where people stay..."<sup>19</sup>

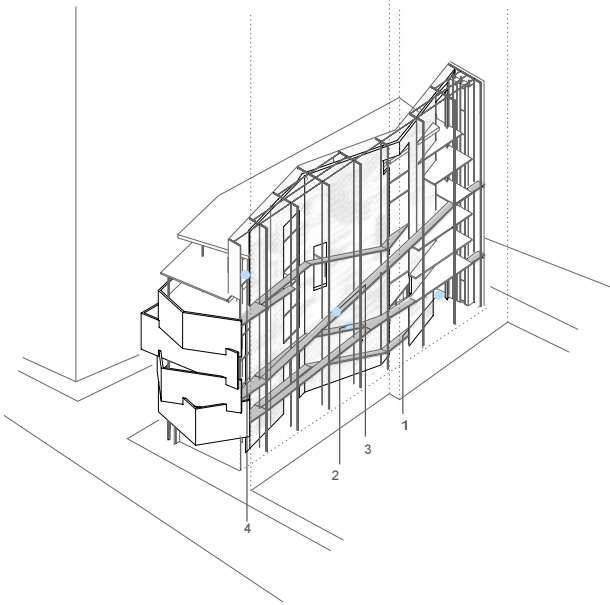

unlike the detached lives induced by stacked up floors of many new york city buildings, the proposed building aims to promote interaction between various functions housed within itself. the **ramp** is designed together with the gallery as a means to **interlock** the spaces. It takes people from the street level; it pierces through a break in the folded wall and leads them to the gallery floors and to the gallery café at the fifth floor. As one goes up along the ramp, the view



view from the wall street entrance towards the ramp... 1 2... view from the ramp to 3rd floor office



shifts, extends beyond the breaks and the transparent skin towards the interior spaces and vistas of the site. the ramp and the spaces on the other side of the wall are **interwoven**. the visual connection is provided into the spaces which are inaccessible via the ramp and from those spaces to the ramp. The dynamic spatial experience enhances the interaction between lives in diverse floor levels within themselves and with the life outside the building envelope.

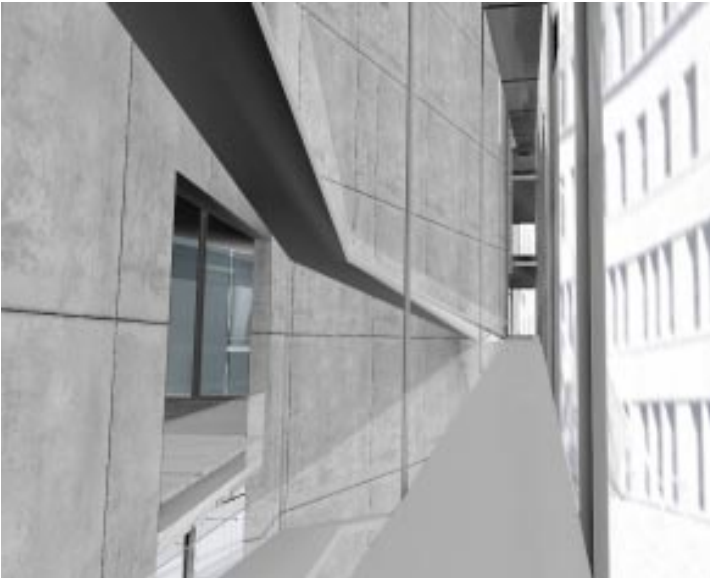

view from the ramp to the 4th floor gallery and the neighboring skyscraper... 3



4... view from the top end of the ramp

## w a l l o f c o l u m n s

the unique location of the site 'on' wall street, brings up the challenge of connection to the street life of the district. as the building houses galleries located on street level and on several other floors together with a gallery café, it leads, opens up and invites the people on the street into these spaces to promote the transformation of the district into a work-live neighborhood. in order to provide maximum transparency and openness towards the street, a row of thinnest possible steel columns forms the blur **threshold** between **outs**ide and **in**side. the transparent glass envelope is also detached from these columns forming another layer of in-between space. the diverse positioning of the clear skin with respect to the columns, either in front or behind them, provides the experiential moments for the entry to the building, while emphasizing the separation from its structure. one approaching the building from the wall street side enters from the tail of the building in-between the folded wall and the **row** of **columns**, whereas one coming from the river-side enters in-between two transparent glass planes attached to single columns on either side with a thin tension structure. the limits of the building boundary are vague from the street and the interior, interweaving them spatially.

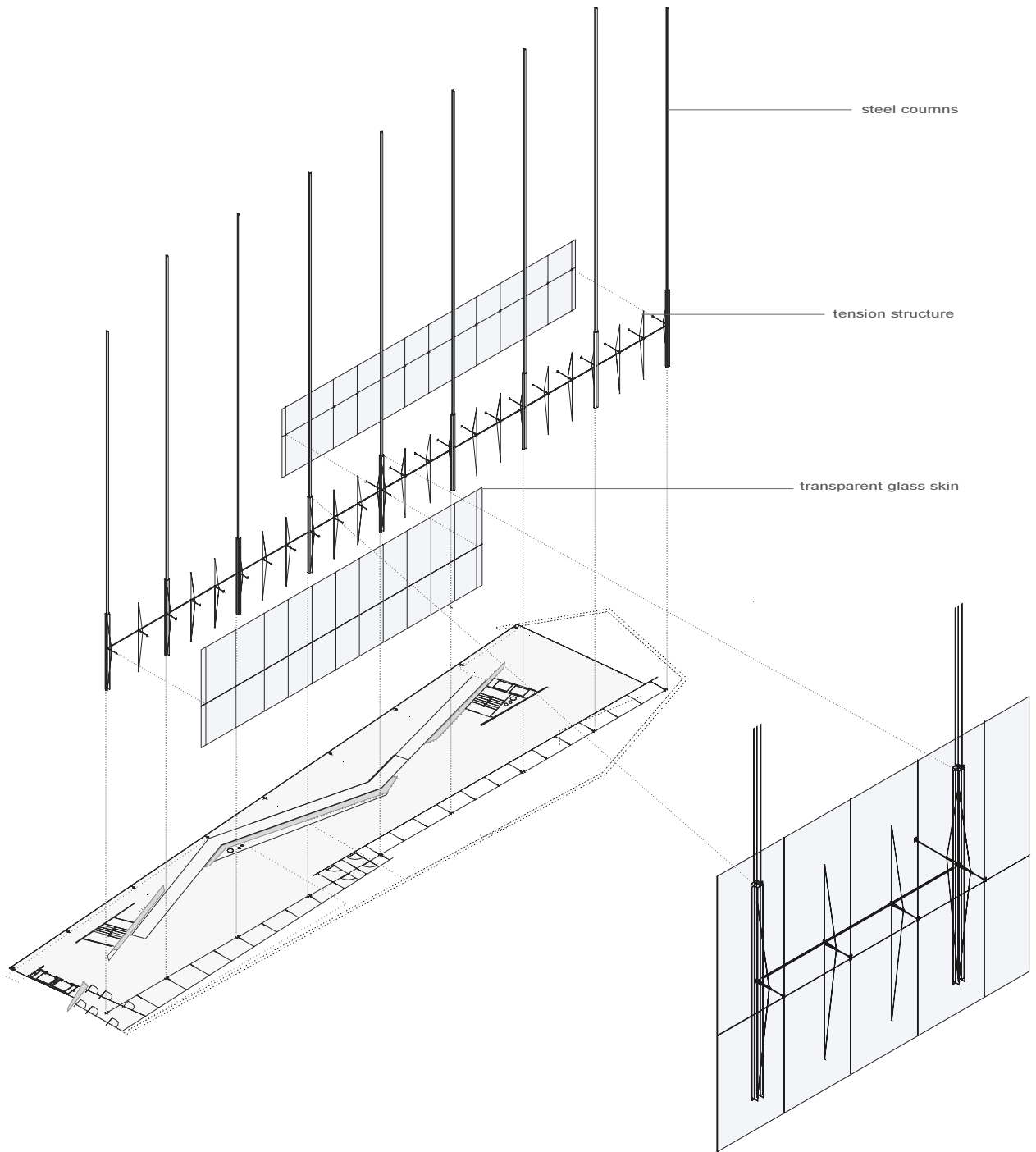

column structure and transparent skin

## w a l l   v e r s u s   f r a m e

the separation between wall and frame is a blur-threshold in the architectural discourse. they both delimit the space and perform as the **barrier** and the **seam** between delimited and enveloped spaces. they differ with respect to their expression of the density of boundary between inside and outside. while the massive wall demarcates and bears, the skeletal frame differentiates between demarcating and bearing. the wall implies closure, isolation, protection. it wraps and closes a space. its thickness, surface treatment and degree of transparency defines its expression of enclosure. the frame implies openness. it concentrates support, minimizes the mass and lightens up boundaries of space. the intercolumnation defines the degree of penetrability versus enclosure. inside and outside penetrate into each other, merging without a concrete barrier, although the threshold is defined. in the case of the project, these characteristics of the wall and the frame are explored and articulated in the 'folded wall' and the 'wall of columns' respectively.

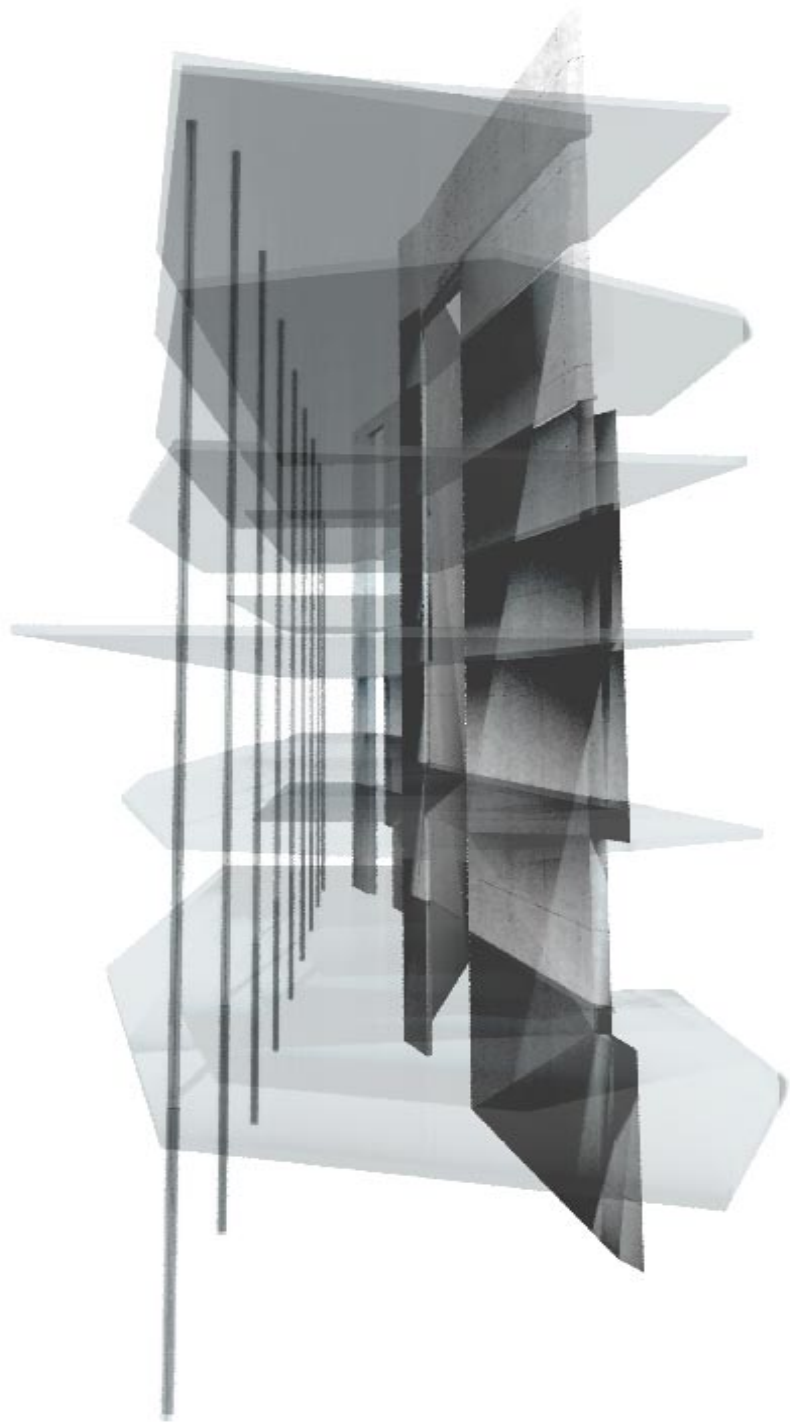



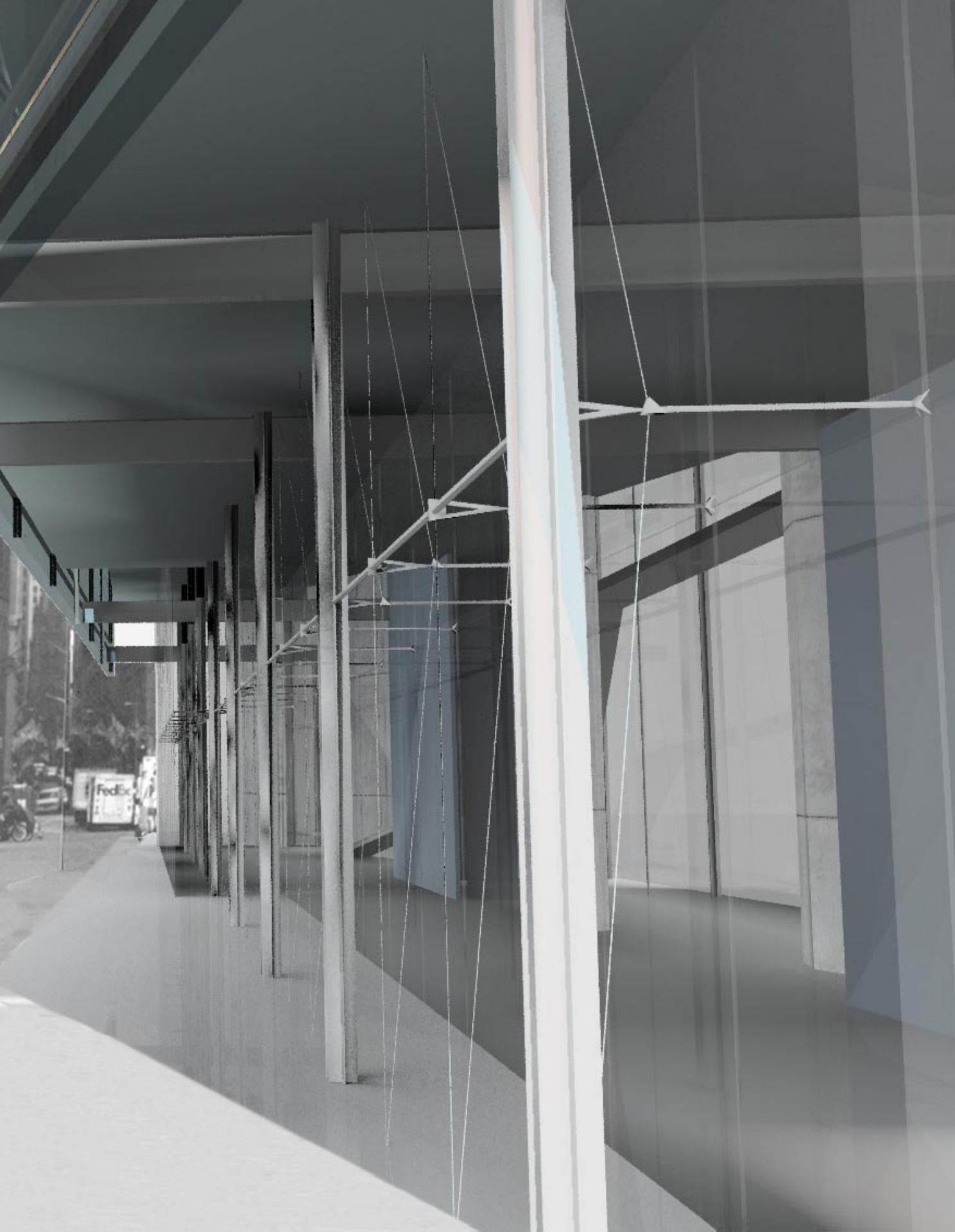









view from the street level gallery to wall street

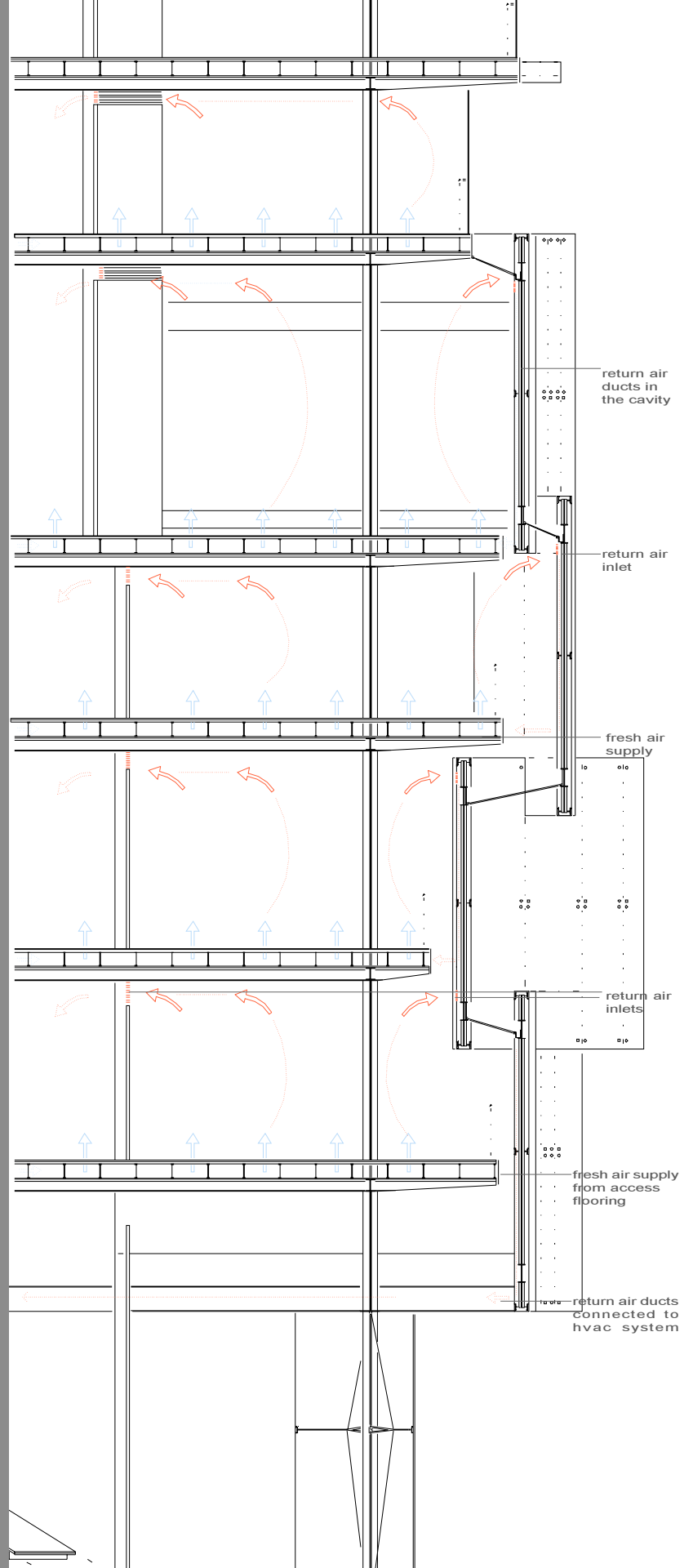
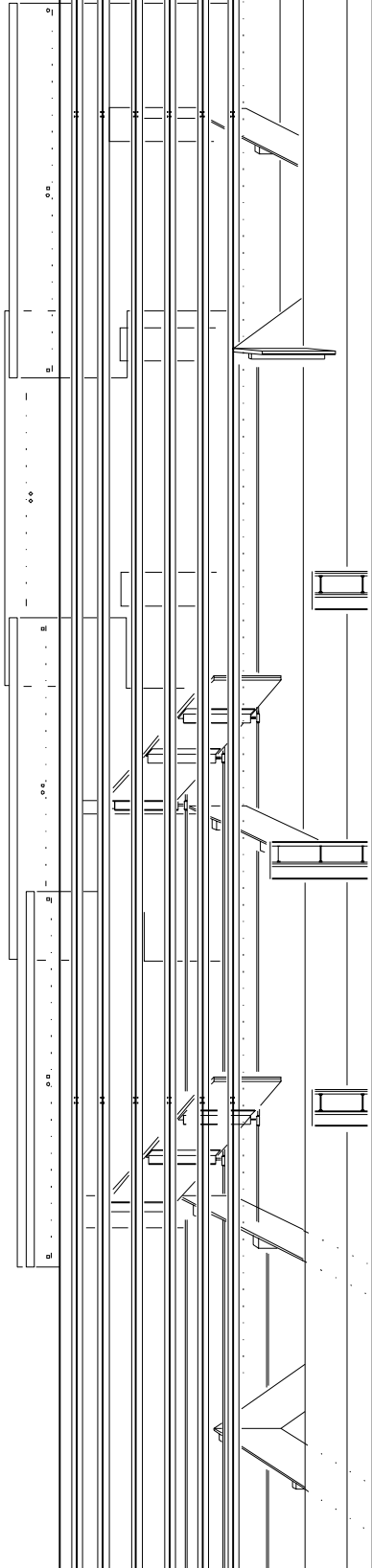

## energy efficiency and double facade

the **crystal-like** building provokes questions and concerns regarding energy efficiency through its life cycle. the problem of heat loss during winter and overheating during summer directed the quality and types of **glass** used in divers sections of the building as critical issues in the design process. in order to achieve maximum efficiency through optimum use of natural light and air flow without compromising the essential architectural decisions, special emphasis is given to thickness, insulating properties and light transmission values of glass panes, percentage of low -e coating, pattern and density of acid etching depending on the objective and the position of various glass panes throughout the building. the cavity created in-between two panes of glass of the ribbon walls is integrated with the hvac system of the building in order to take advantage of the **double facade** systems. the fresh air, which is supplied to the interior spaces through the access flooring, is collected and returned to the hvac system through the inlets which are located at the points where the walls of the service boxes touch the ceiling plane. the air along the periphery of the ribbon walls is returned through air inlets positioned on the inner face of the front skin and is taken down and back to the hvac system through the ducts which are located in the cavity. the implemenation of the double facade system is proposed to compensate the energy loss due to the north facing, transparent glass atrium wall. the moving air is heated in the void during the summer and dumped outdoors by the hvac system, thus lowering the need for mechanical cooling. during the winter, the solar heated air in the void could be transported to the northwest oriented all-glass atrium side. additional improvements in the energy efficiency of the building were explored through use of '**energy 10**' as a testing tool during the design process. the primary strategies ranked by the program, such as effective use of **thermal mass, shading, insulation** and consideration of economizer cycle, influenced the decisions regarding properties and dimensions of design elements and materials. maximum efficiency increase is provided by additional mass in the folded wall. an increase in shading coefficient values of south, east and west facing glazings and additional insulation in the floor and roof construction improve the overall 'u' value. the application of economizer cycle provides the control of temperature at the atrium side during the night time by letting the temperature swing as the building may be partly used by night. 55% decrease in annual energy use, 84% decrease in energy use for heating, 39% decrease in energy use for cooling and 21% decrease in energy used for interior lights are acheived through implementation of these strategies when compared to conventional construction and operating conditions.

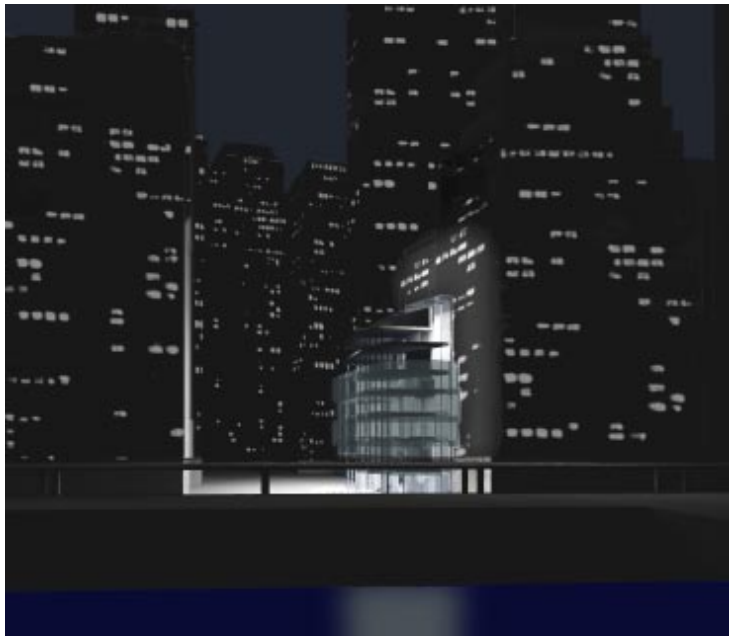

view of **glowing** object from east river side



crystalline at the end of wall steet

“...an architecture based on a limited concept begins with dissimilarity

ribbon wall  
folded wall  
atrium wall  
wall of columns

wall  
layers



joint  
break

and variation...it illuminates the singularity of a specific situation..."20

overlap  
shift

quotes...

1. El Croquis no.78. '*Steven Holl*', quote by Steven Holl. Madrid: COAM Publicaciones, 1996
2. Rencoret, Francisco Javier. '*New York City, the edge of Enigma*', Princeton Architectural Press, 1991
- 3 + 4. Vanderbilt, Tom. article '*Can a residential neighborhood be carved out of the financial district?*'
- 5 + 6 + 8. Van Alen Institute. '*1996 Paris Prize in Public Architecture: Cultural Information Exchange: Proposal for a temporary building in Wall Street*', program statement, [www.vanalen.org/competitions/culture\\_exchange/program.html](http://www.vanalen.org/competitions/culture_exchange/program.html)
7. Daidalos, no.68, '*Luminous Bodies*', quote from Erich Mendelsohn, April 1998 page 28
- 9 + 14. Plummer, Henry. '*Light in Japanese Architecture*', E ando Yu, 1995
10. Riley, Terence. '*Light Construction*', quote from an article for Pierre Chareau's Maison de Verre by Kenneth Frampton, New York Museum of Modern Art, 1995
- 11 + 17. Daidalos, no 39. '*The Meaning of Wall*', article by Pearce Scott, 1991
12. Frost, Robert. '*Mending Wall*', poem, 1914
13. Architectural Record. no 8. a quote by '*Herzog & De Meuron*', August 1999
14. Techniques et Architecture, no.445 '*Towards the invisibility of the buildings*', article by Guilhex, Alan. page 20
15. Zumthor, Peter. '*Kunsthhaus Bregenz*', Verlag Gerd Hatjz, 1999
16. Frampton, Kenneth. '*Rappel a l'ordre*', Architectural Design, 1990 page 25
- 18 + 19. Alexander, Christopher. '*A Pattern Language: towns, buildings, construction*', article '*Zen View*', New York: Oxford University Press, 1977
20. Holl, Steven. '*Museum of Contemporary Art Helsinki*', Museum of Contemporary Art and the Finnish Building, 1998

## selected bibliography...

1. Koolhaas, Rem. *'Delirious New York , a Retroactive Manifesto for Manhattan'*. New York: Oxford University Press, 1978
2. Leich, Jean Ferriss. *'Architectural Visions, drawings of Hugh Ferriss'*. New York: Whitney Library of Design, 1980
3. Rencoret, Francisco Javier. *'New York City: the edge of Enigma'*. New York: Princeton Architectural Press, 1991
4. Klein, William. *'New York 1954-55'*. Manchester (England): Dewi Lewis Publishing, 1995 (photographic credit page 214)
5. Cohen, Paul E. + Augustyn, Robert T. *'Manhattan in Maps 1527-1995'*, New York: Rizzoli International Publ., 1997
6. Watson, Edward B. *'New York Then and Now: 83 Manhattan sites photographed in the past and in the present'*. New York: Dover Publications Inc, 1976
7. Risselda, Max. *'Raumplan versus Plan Libre'*. New York: Rizzoli International Publications, 1988
8. Thiis-Evenson, Thomas. *'Archetypes in Architecture'*. New York: Oxford University Press, 1989
9. JAE 1994 May. *'Wall in Recent Architectural Form'*. page 242
10. Architectural Review 1997 July-Sept.. *'Illuminating Volumes'*. page 4
11. Rowe, Colin. *'Mathematics of the Ideal Villa and other essays'*. article *'Transparency: Literal and Phenomenal'*. Cambridge, Mass. MIT Press, 1976
12. King, Carol Soucek. *'Designing with Glass: the creative touch'*. New York: PBC International, 1996
13. Compagno, Andrea. *'Intelligent Glass Facades: material, practice, design'*. Zurich: Artemis, 1995
14. Rice, Peter. *'Structural Glass'*. London: New York: E & Fn Spun, 1995
15. Architectural Design: Deconstruction II no. 1/2. *'Dispersed, Multi- Layered Space'*. article by Hiromi Fujii. page 67
16. Gunay, Reha. *'Tradition of the Turkish House and Safranbolu Houses'*. Istanbul: Yapi Endustri Merkezi Yayinlari, 1998 (photographic credit page 75)
17. Ito, Teiji. *'Space and Illusion in the Japanese Garden'*. New York: Weatherhill, 1973

selin ozertugrul... 02/1 1/1975... curriculum vitae...

may 2000\_ **master** of **architecture**... june 1996\_ **bachelor** of **architecture**

virginia polytechnic institute and state university,

blacksburg,va,usa

middle east technical university

ankara,turkey

special **thanks** to my extended **family** + very good **friends**; to Bill Price,



Bill Galloway

Jim Jones

Warren Kark + Michael O'Brien; to my **committee** members Heiner Schnoedt

Bill Brown