

B r u s h M o u n t a i n

a n e x p l o r a t i o n



o f s t r u c t u r e

R a n g e r S t a t i o n

C o l i n J . S m i t h

**Brush Mountain Ranger Station
An Exploration of Structure**

by
Colin J. Smith

Thesis submitted to the faculty of the Virginia Polytechnic Institute
and State University in partial fulfillment of the requirements
for the degree of

Master of Architecture

Approved by:

William W. Brown, Chairman

William U. Galloway

Michael J. O'Brien

Blacksburg, Virginia
July 1999

a b s t r a c t

The thesis is an inquiry into what is architecture, and what are the ideas that influence architecture and its creator, the architect. The resulting answer is structure. Structure is the essential component of architecture. It gives form and limits to a space, and provides a medium to transform the ideological into the physical. What comprises this structure, and how it is translated into the built environment is an ongoing investigation. However, certain elements can be deemed influential in dictating how this structure is expressed. These include the major components of the structure, base and frame. The base responds to the site and provides a place for the frame. The frame defines the limits of the space and gives and order to the project. Further review of the frame reveals two additional elements of structure, connection and infill. The study of connection lends itself to the belief that architecture can be found in the details, while the use of infill gives way to the examination of an opening in a wall, and the light or view that it creates. When these four elements of building work together, the creation of architecture and structure begin to unite into a single process. The result, in this case, is a project that forms a path through the woods and builds a relationship with nature.

Thanks to my committee members,
Bill Brown, Bill Galloway, and Mike O'Brien,
for their insight and direction.

Special thanks to my family and friends for their love and support.

c o n t e n t s

abstract	i
the project	
base	1
frame	8
connection	15
infill	24
path	33
appendix	42
bibliography	53
vita	54

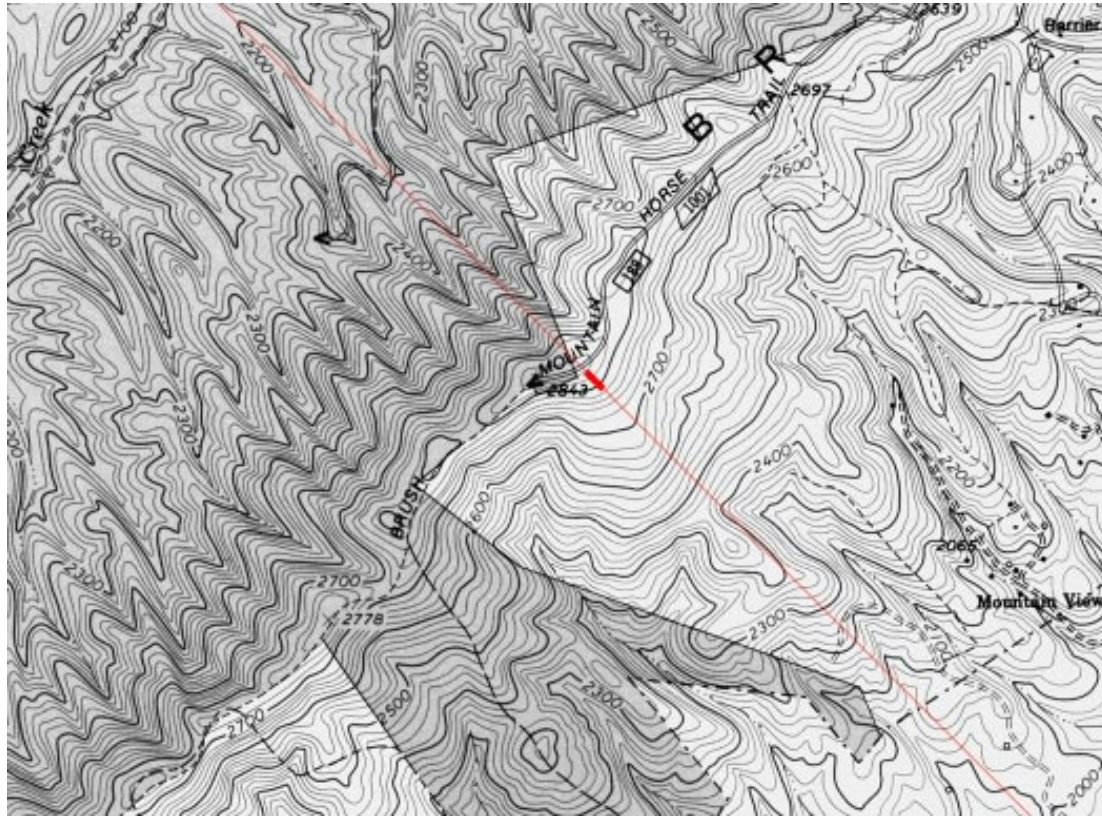

base (bās) n.

1. a. A supporting part or layer; a foundation. b. A basic or underlying element; infrastructure.
2. The fact, observation, or premise from which a reasoning process is begun.

Architecture begins with making an act on a site. Without a site, architecture does not exist. Therefore, it is important that one responds in a positive manner to that which nature has provided. Before making a decision regarding this action, an initial examination of the site was made. Brush Mountain is located in the Jefferson National Forest, just outside of Blacksburg, Virginia. It is a popular area used by hikers, mountain bikers, and horse enthusiasts. A fire road leads up the side of the mountain to the summit, and many trails access this road. Situated at the top of the mountain along the ridge line, is an existing lookout cabin. It is a simple A-frame structure made of wood. A masonry wall rises up out of the ground to support the cabin. It is this feature, the foundation wall, which began a look into the concept of base, and the making of a place for architecture.

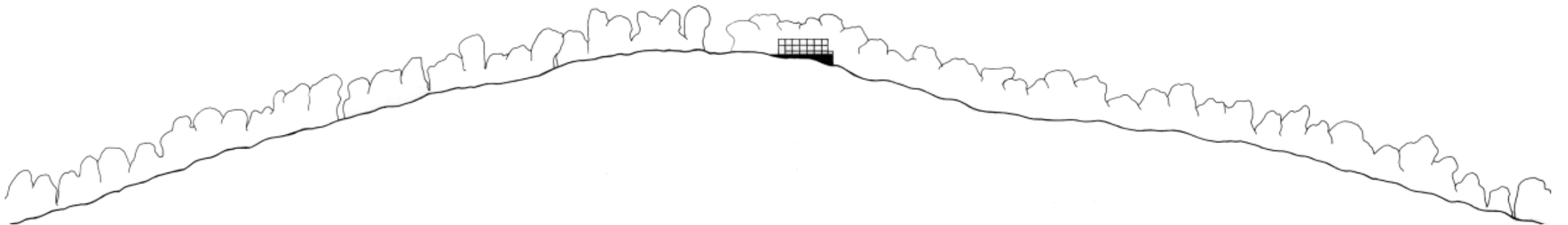

2

The base in the project takes the form of two stone walls placed perpendicular to the ridge line. They extend across a narrow site toward an opening in the trees, with a view overlooking the valley. The close proximity of the walls creates a narrow passage, one that will limit the damage of the natural surroundings. The height of these walls remains constant along their elevation, in contrast to the declining topography of the land. This change in topography allows for a section of the building to be underground, essentially becoming part of the mountain.

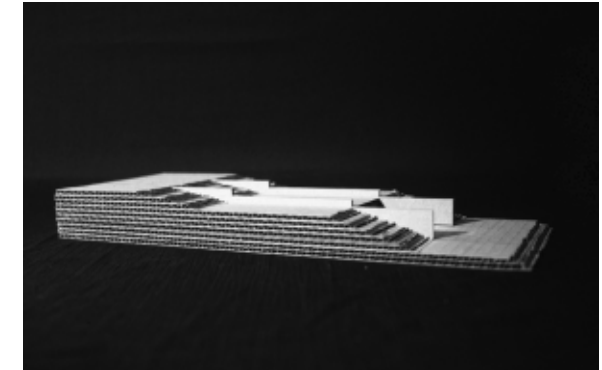
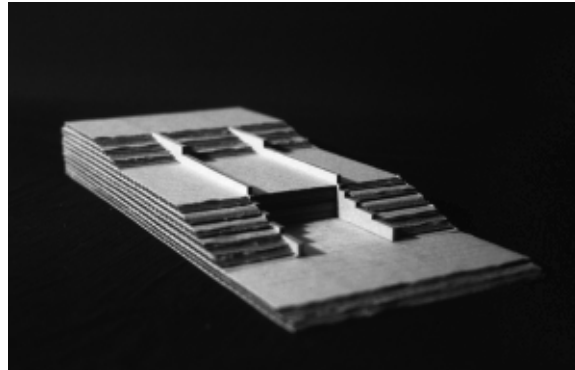
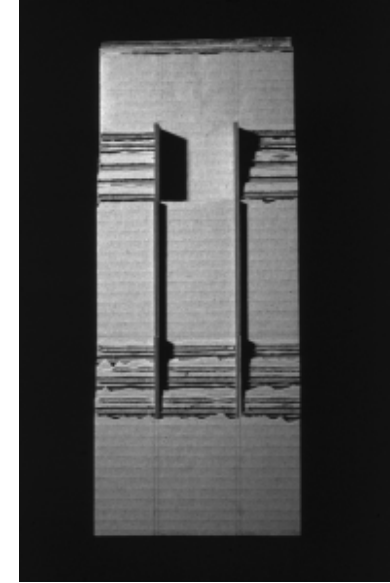
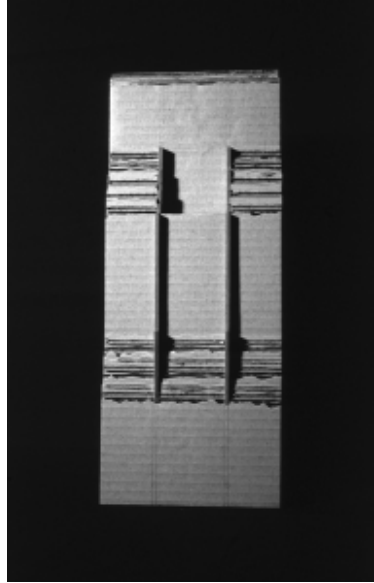

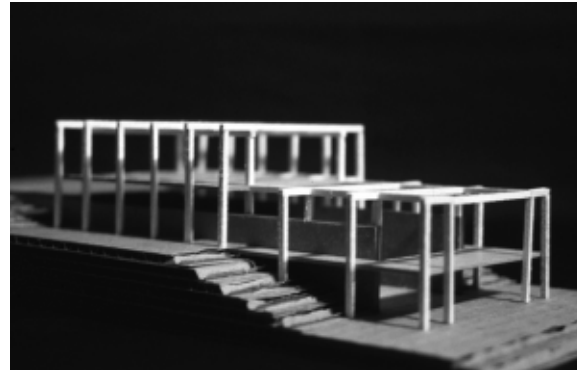
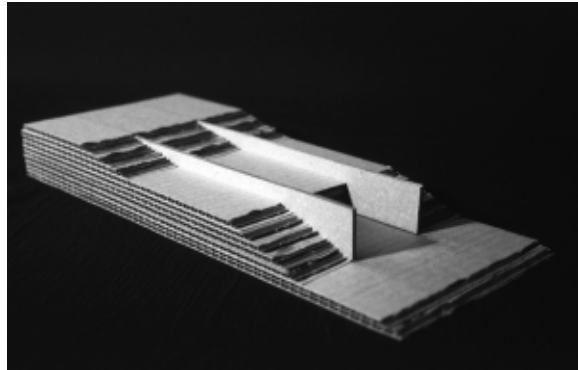
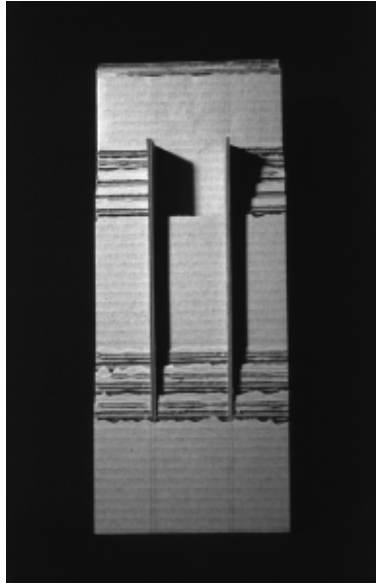

Study of wall typology and its relation to the slope of the land.

Just as the earth provides a place for the walls to rest, the stone walls, in turn, will act as a base for the timber structure to sit on. The idea of a light structure upon a heavy base is not a new one. It was originally discussed by Gottfried Semper. He divided the built form into two separate material procedures: the tectonics of the frame and the stereotomics of compressive mass. This mass is constructed through the stacking of similar units. The term stereotomics derives from stereos, or solid, and tomia, which means cutting. The tectonic usually consists of a frame that has members of varying length. These members are then joined together to create a space. The idea of tectonic stems from construction, or assembling, and will be discussed more in the next section.

4

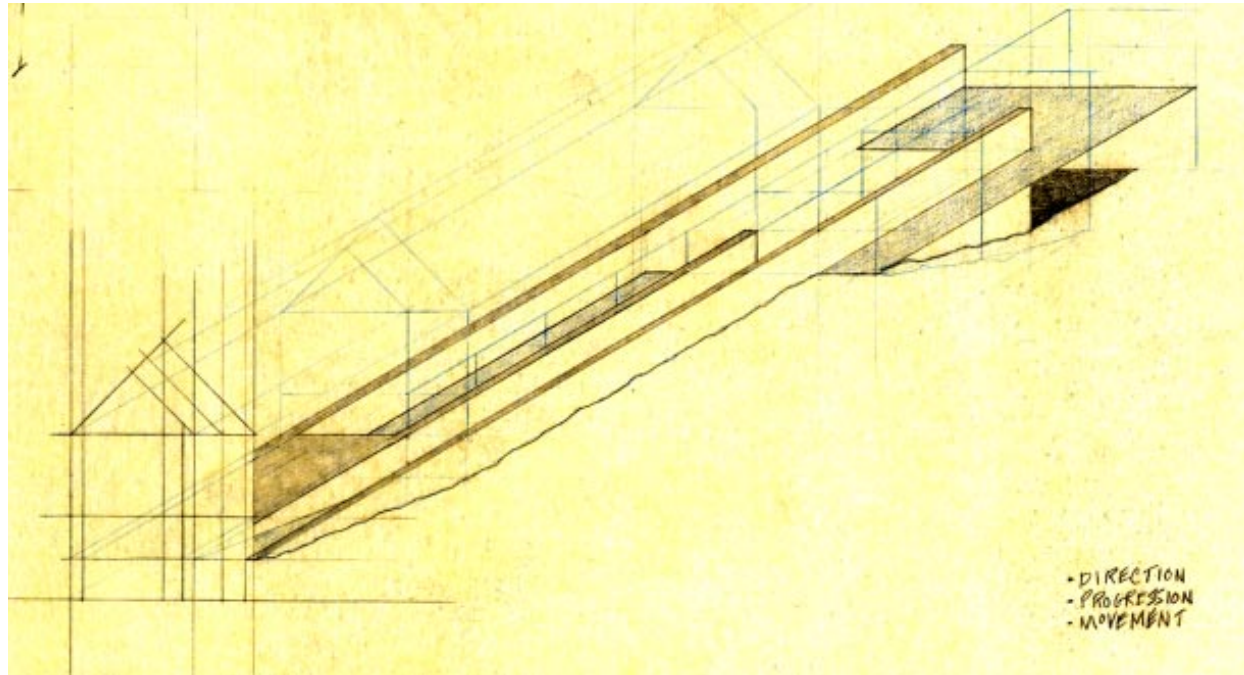

The stone base gives the building weight and presence on the site, and provides an axis for movement through the space.

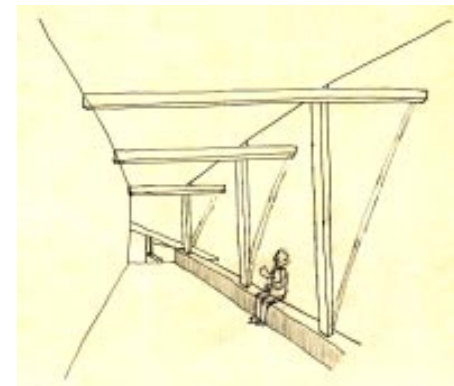
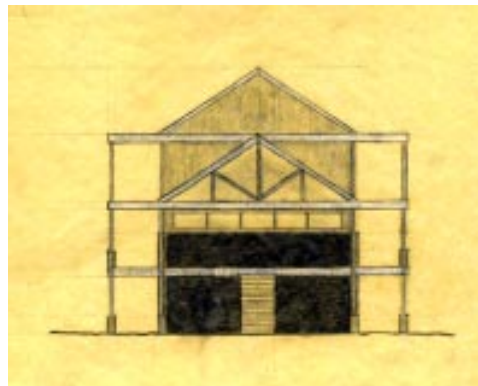
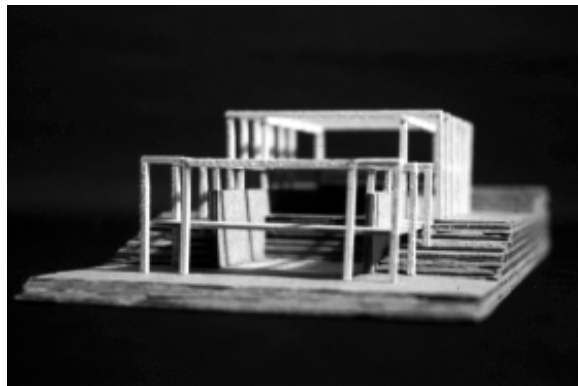

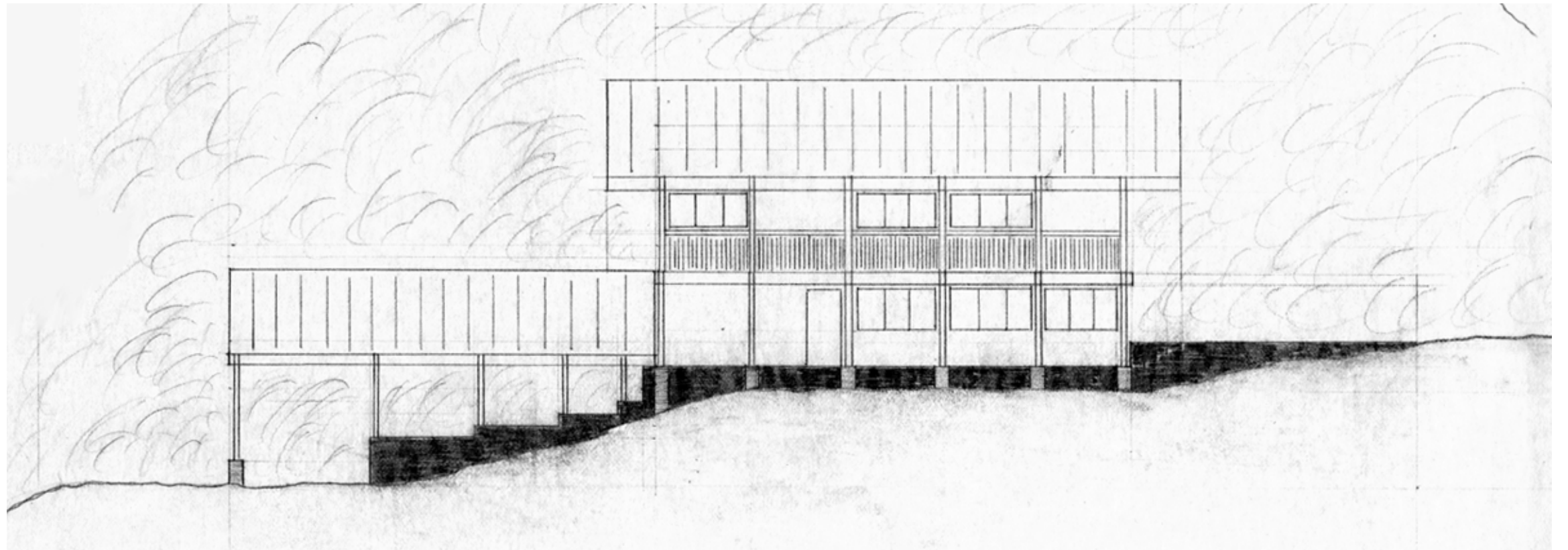

5

The continuity of the wall helps to tie the repetitive elements of the frame into a single structure. The early drawing, above, of the base/frame relationship was influenced by the existing wall, shown to the right.

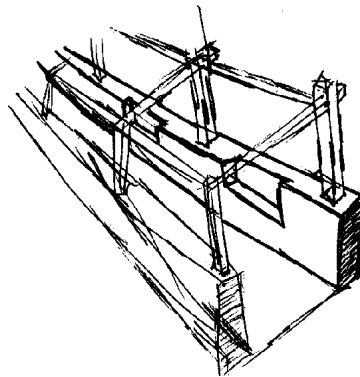
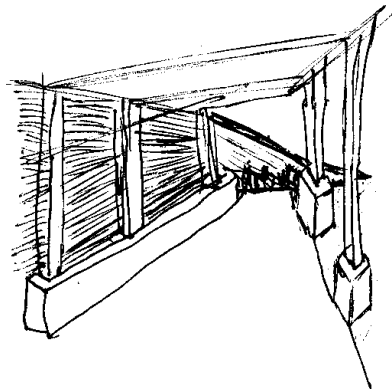

“The making of ground, rather than the primitive hut, is the primordial tectonic act.”

Vittorio Gregotti

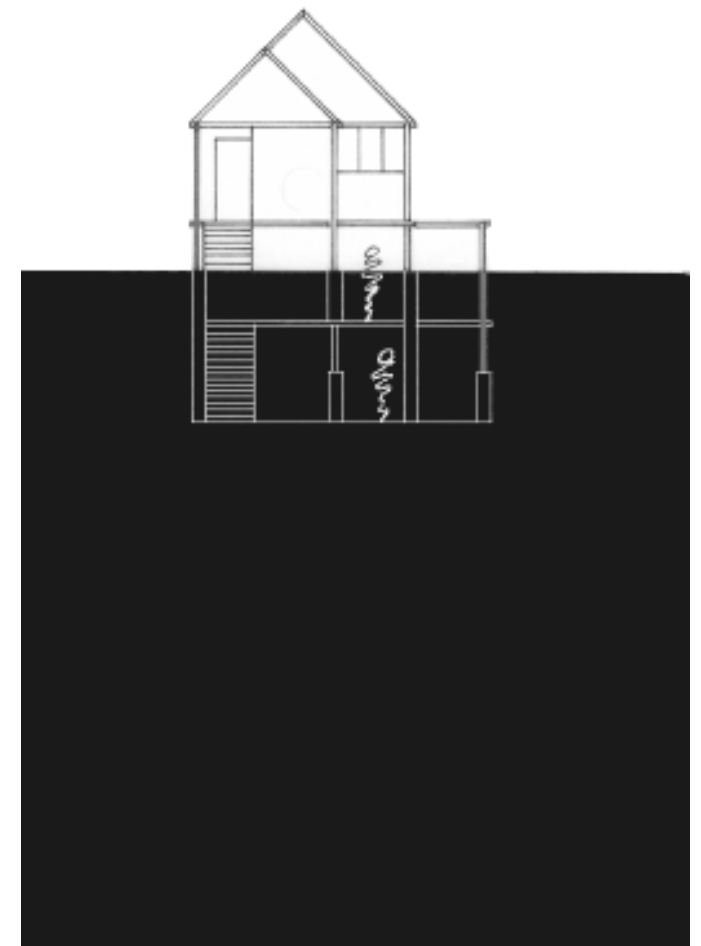

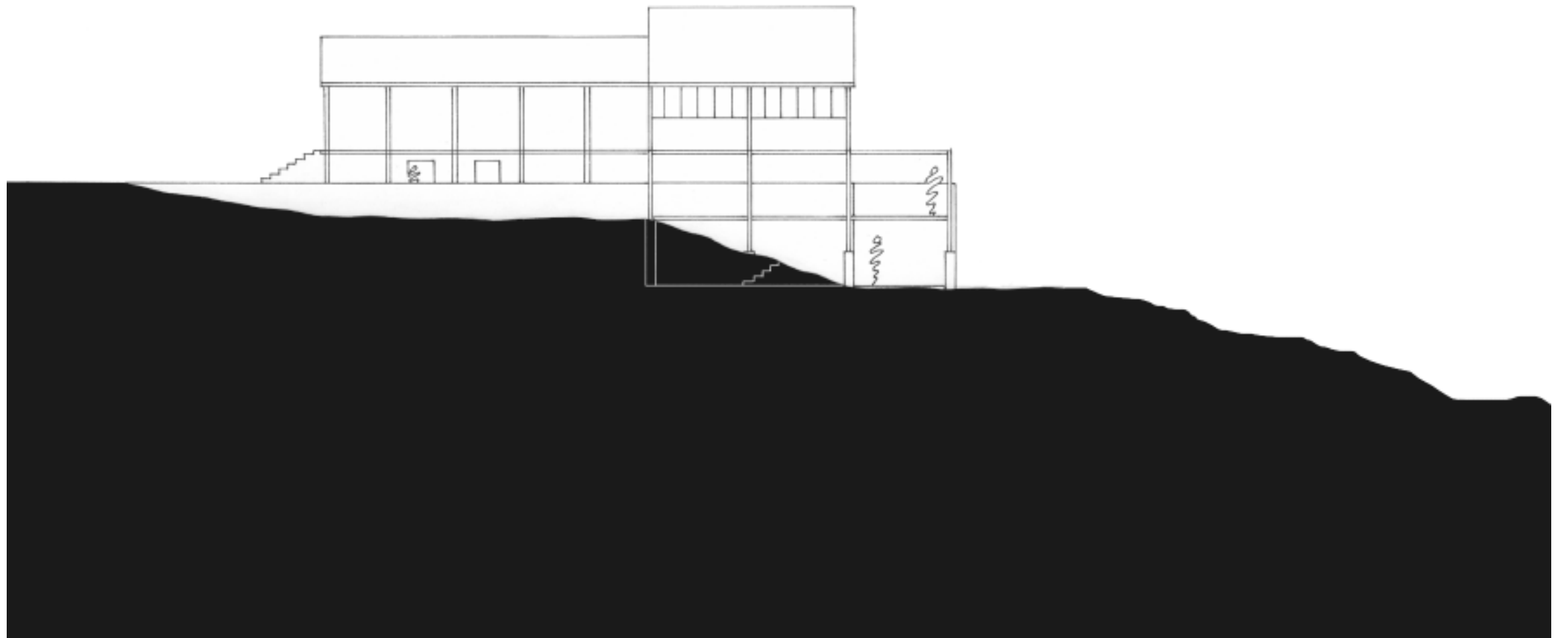



frame (frām) n.

1. Something composed of parts fitted and joined together.
2. A structure that gives shape or support.
3. A closed, often rectangular border of drawn or printed lines.

The idea of frame consists of numerous concepts, from that of the frame as grid, for organizational and aesthetic principles, to frame as a structure, which gives a building its spatial requirements. One way to better understand the frame, and its purpose, is to compare it further with that of the base. Referencing Kenneth Frampton, the most common material for the tectonic frame throughout time has been wood, while the stereotomic mass has been brick. What can be inferred from this is that the “framework tends toward the aerial and the dematerialism of mass, whereas the mass form is telluric, embedding itself even deeper in the earth.” One leans towards light, or translucence, and the other towards dark, or opacity. The immateriality of the wood frame and the materiality of the stone mass are gravitational opposites, and some believe they could symbolize two opposing features in nature, the sky and the earth.

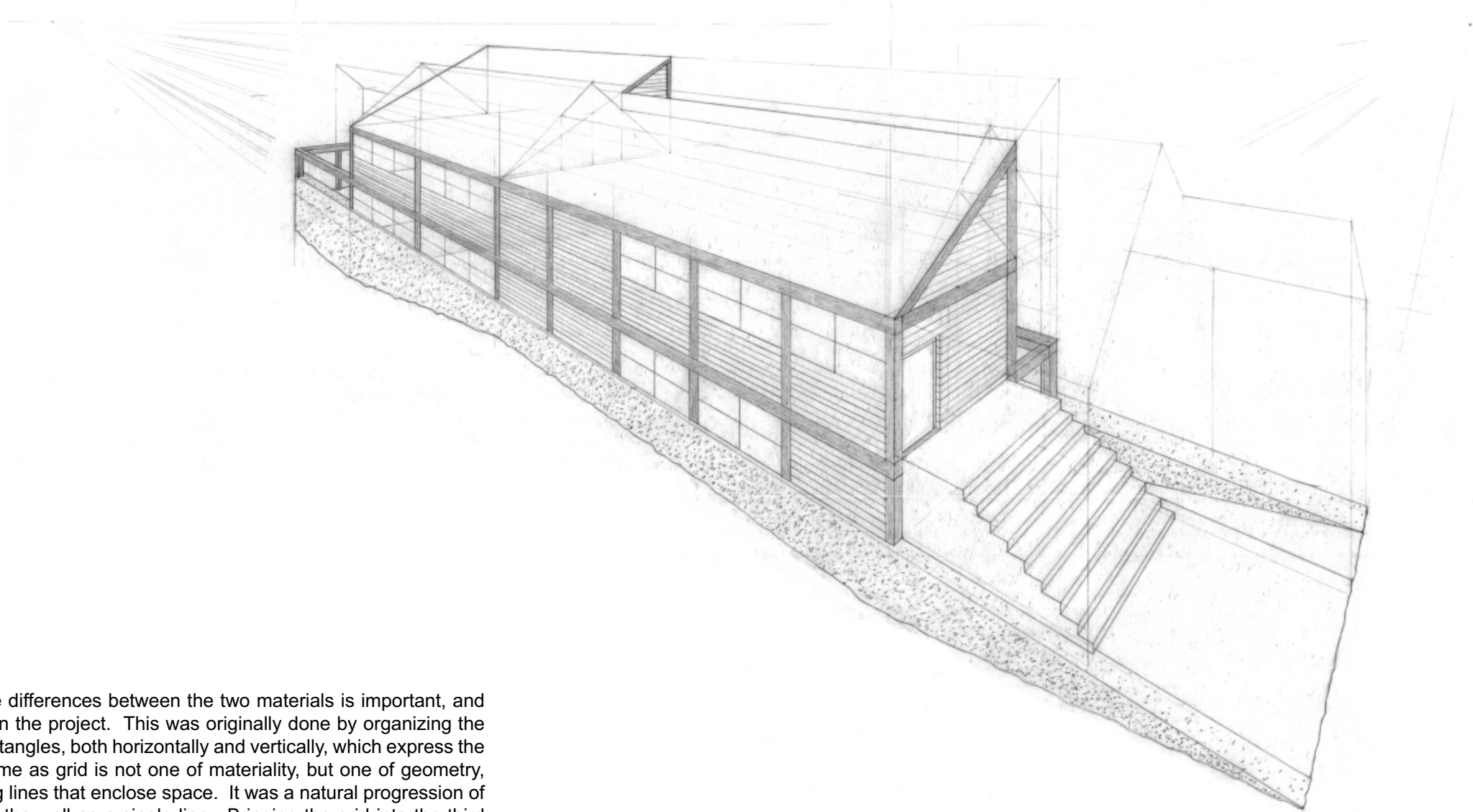

Recognizing the differences between the two materials is important, and should be emphasized in the project. This was originally done by organizing the building into a grid of rectangles, both horizontally and vertically, which express the grid. This thought of frame as grid is not one of materiality, but one of geometry, consisting of intersecting lines that enclose space. It was a natural progression of the line, stemming from the wall as a single line. Bringing the grid into the third dimension was necessary to create a physical presence through mass and volume. It also provided a search into what goes inside a unit of the grid.



Early models showing how the frame extends horizontally and vertically from the base walls, forming a series of interior and exterior spaces to inhabit.

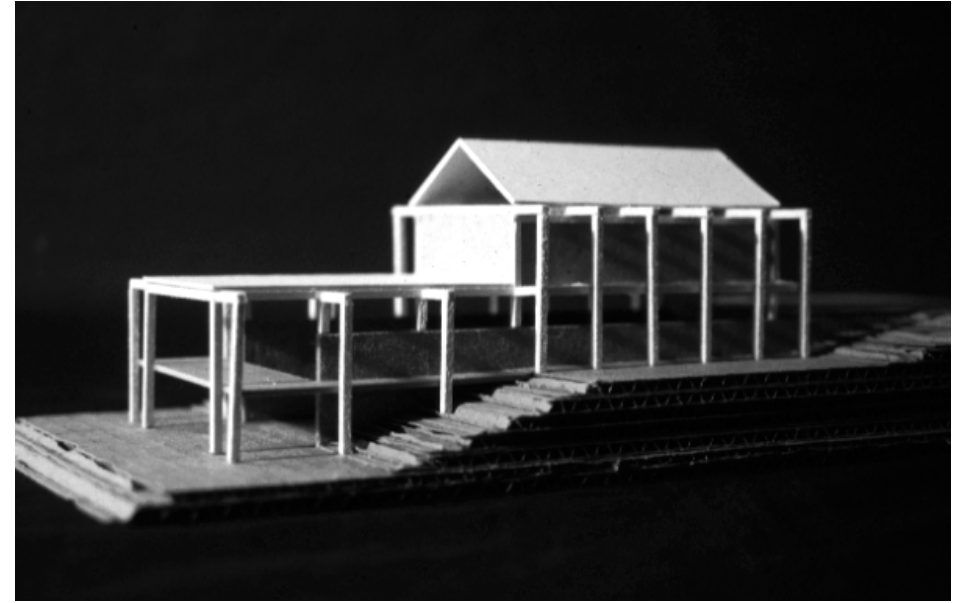

The grid of the frame gives an order and direction to the project, leaving the walls free to be open or closed as needed.

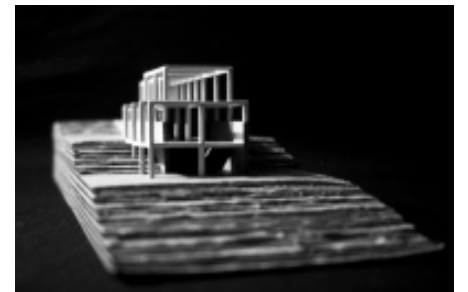
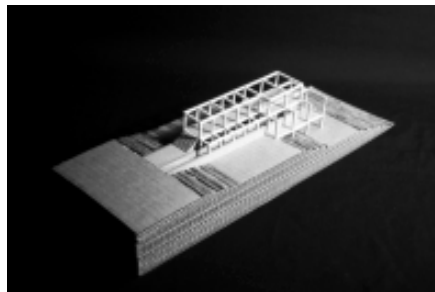
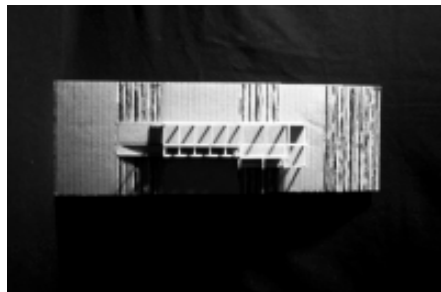

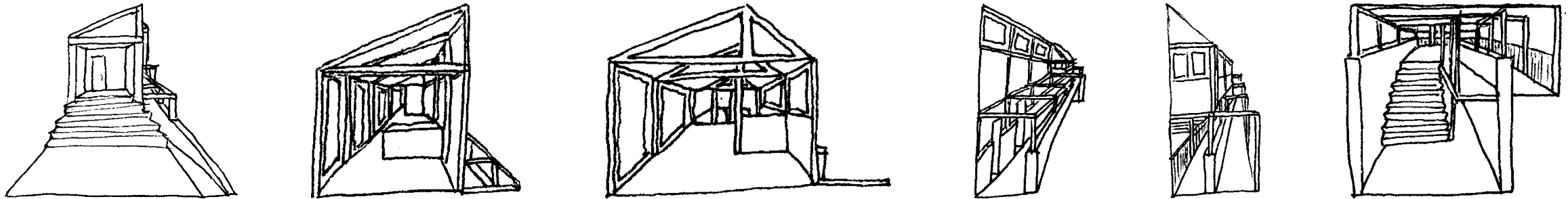

These sketches stress the expression of the frame on both inside and outside the project, and the use of repetition to create a series of bays that act as a single space.

Transforming the grid from a frame into the built environment was the reasoning for looking at the frame as structure. The structure, composed of wood timbers, became the dominant architectural feature of the project and is expressed as such. The use of heavy timber construction allowed the structure to be minimal, emphasizing the grid. The intersection of wood members, instead of lines, gave way to the study of connection and joint.

The structure creates a tall, slender frame, one that meshes with the existing trees of the forest. In order to create an ongoing relationship with nature, the structure has been placed on the exterior of the building. The wood members penetrate the enclosure, and are revealed on the inside. The ability to see the structure from any point was a way to break the separation of man-made building and nature. It helps to mold the entire site into a single architectural experience.



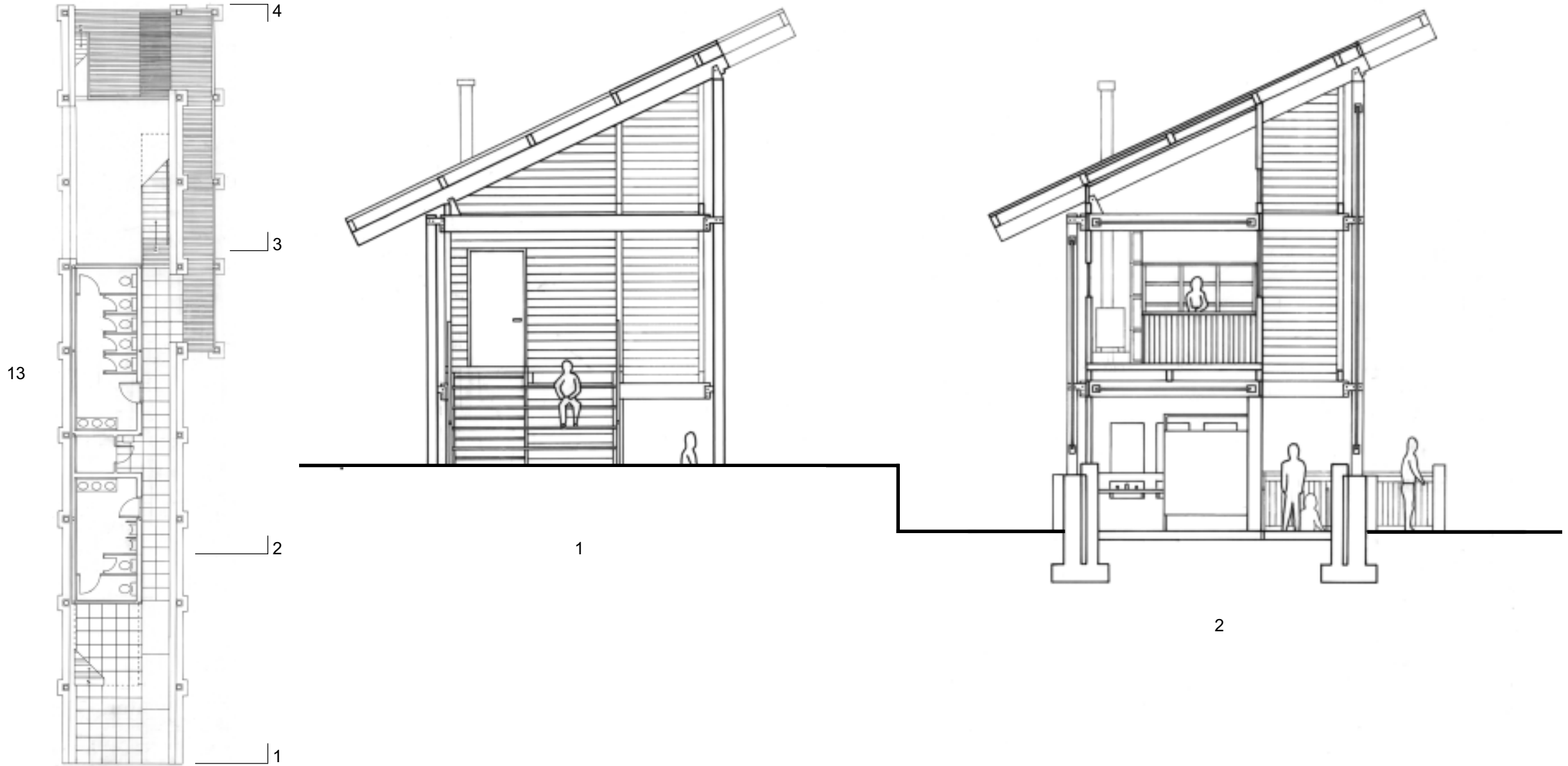

This series of sections and elevations illustrates the interaction between the base, frame, and connection, and demonstrates the how the frame defines the limits of the space.

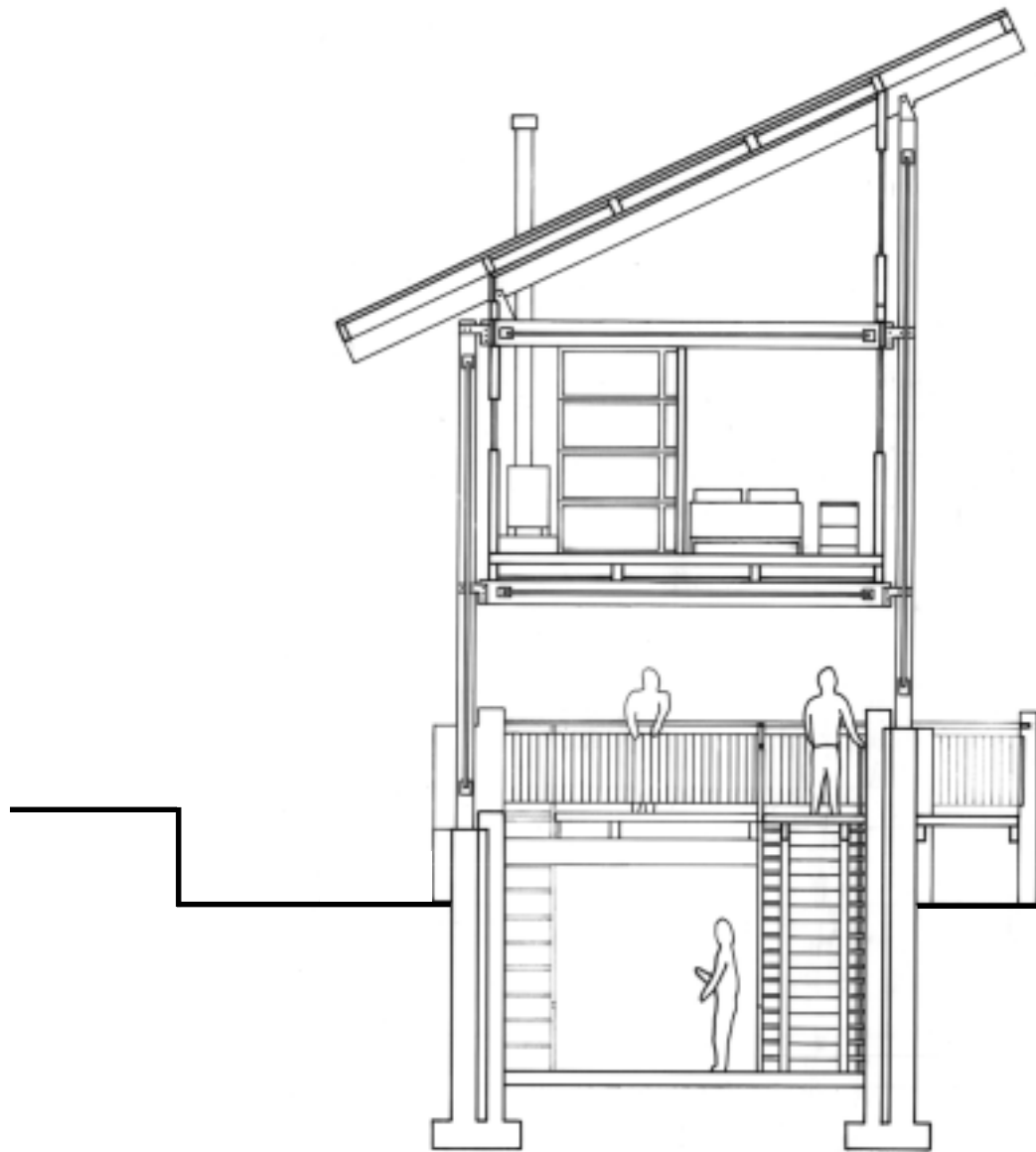

3

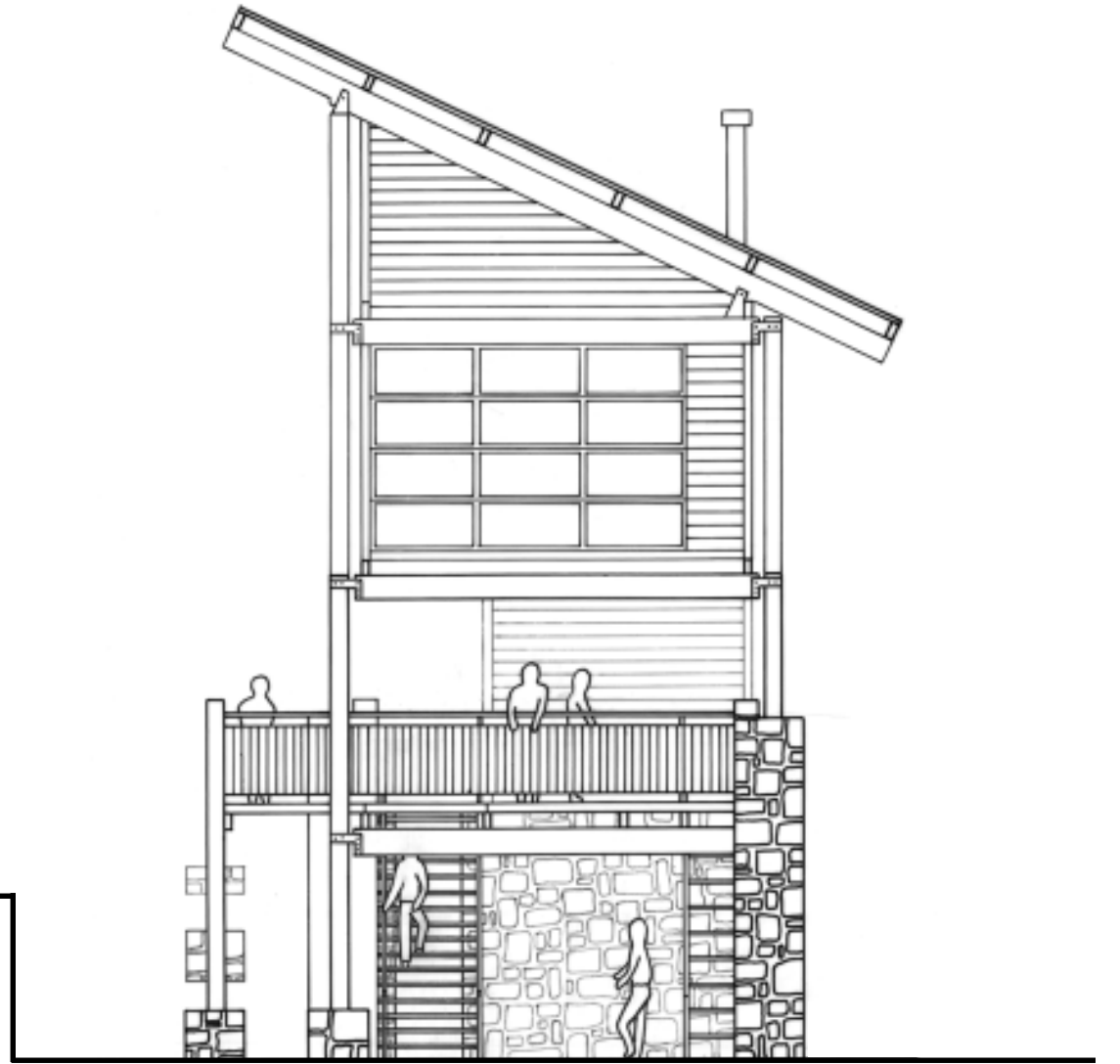

4

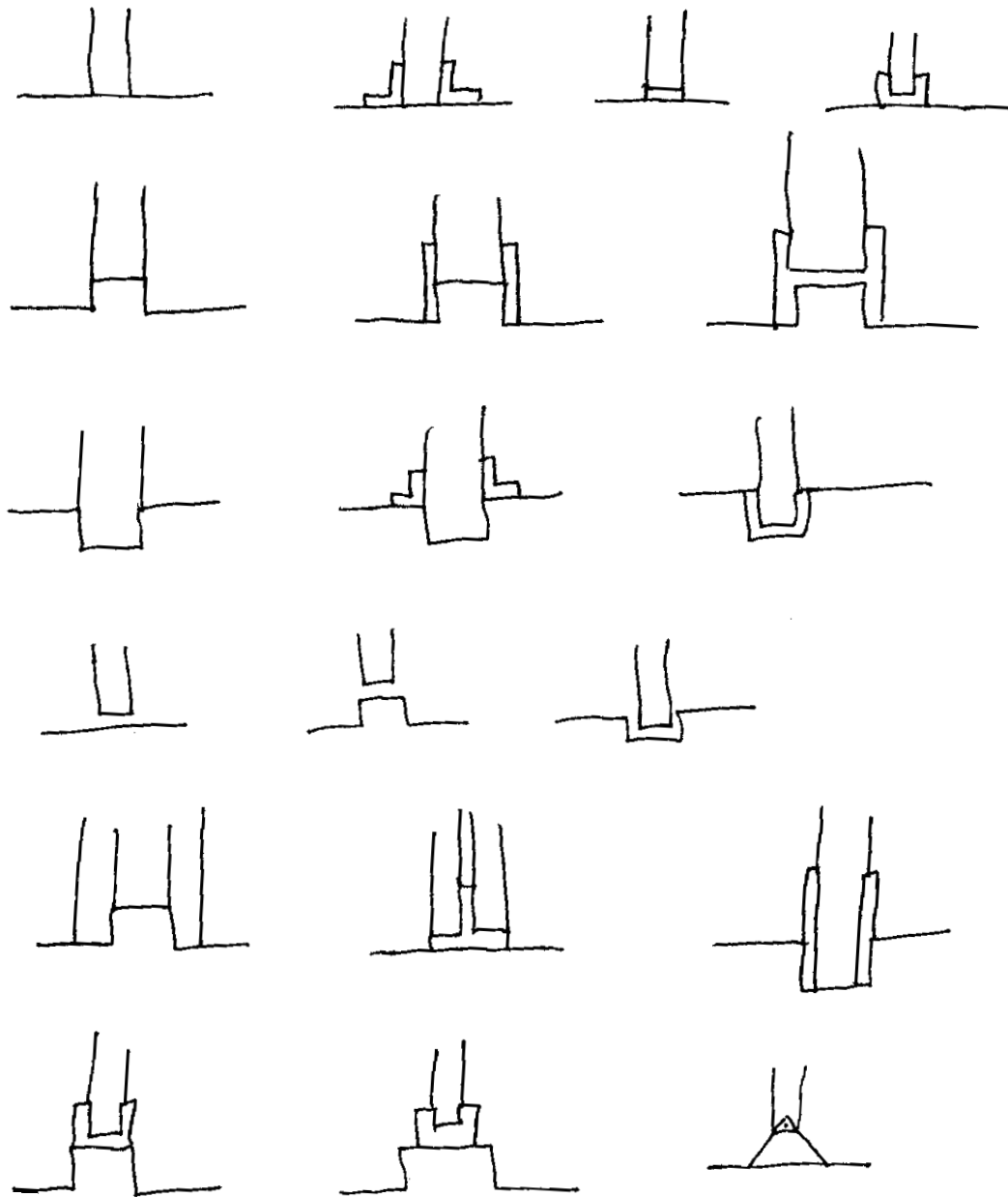

connection (kō-nêk' shōn) n.

1. The state of being joined or fastened.
2. One that connects; a link.
3. The logical or intelligible ordering of words or ideas.

By giving the frame such an aesthetic dominance in the project, it is only natural that an equal importance be placed on how these structural members come together. These connections, sometimes referred to as joints, are vital to the integrity of the structure, as well as the architecture of both the part and the whole. Gottfried Semper maintained that the joint was the primordial tectonic element, and the “fundamental nexus” around which the building comes into being. This emphasis on the joint implies that the “fundamental syntactical transition” may be expressed as one passes from the stereotomic base to the tectonic frame. He felt that such transitions form the very essence of architecture. The knot, he believed, was the earliest basic structural artifact and the ultimate component of the art of building was the joint.

A study of the transition between a column and its base.

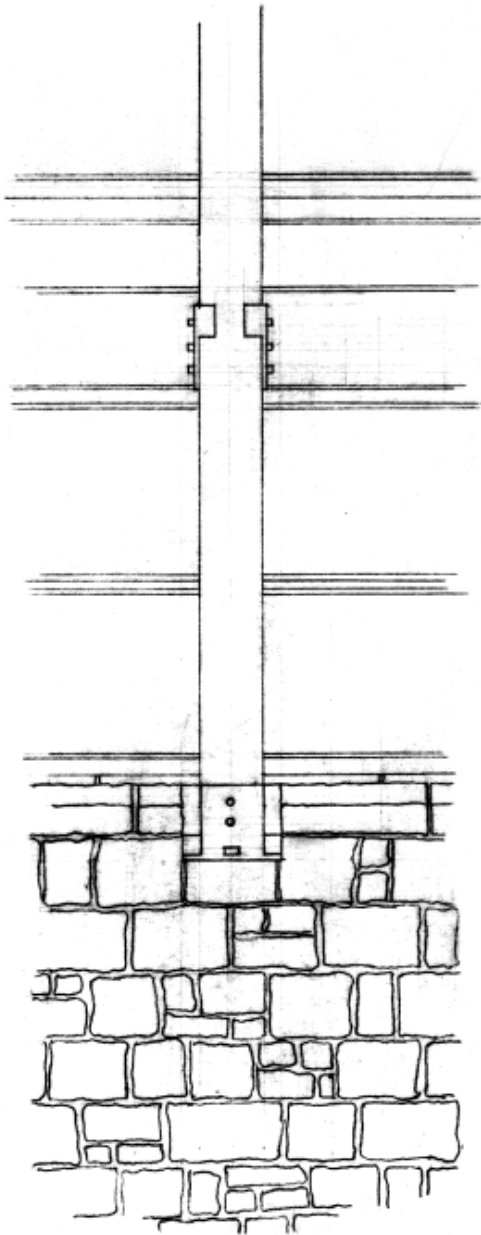

The wall rises up to meet the column, and makes a place for it to rest.

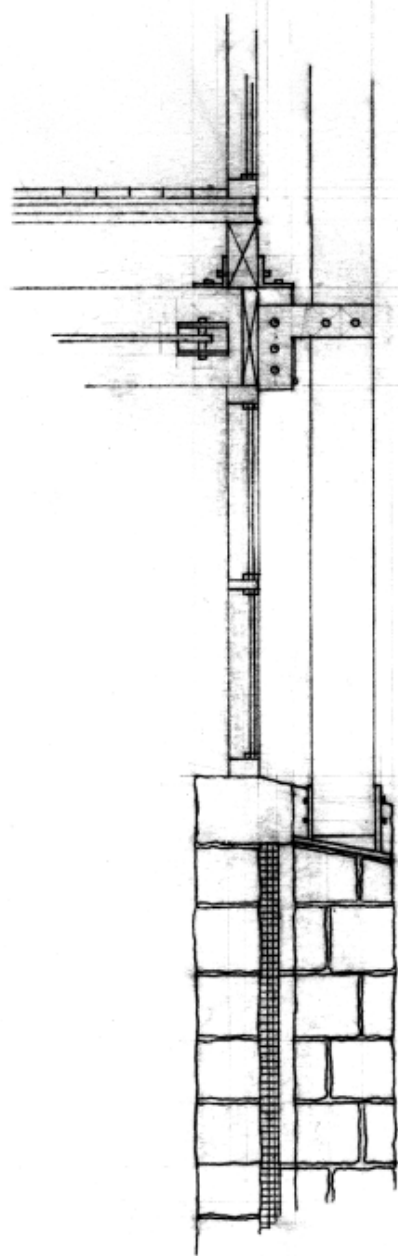

The use of steel connections allows the structure to be placed on the outside of the enclosure.

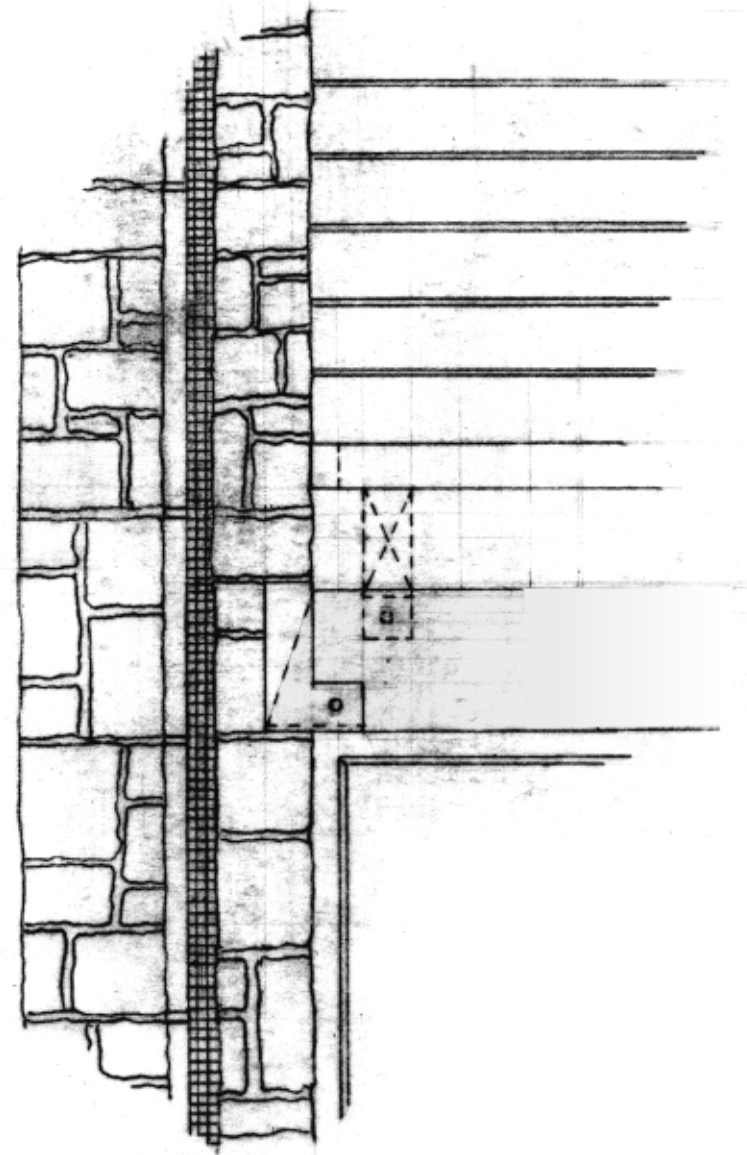

Instead of being attached to the side of the wall, the timber beam is placed within the thickness of the wall.

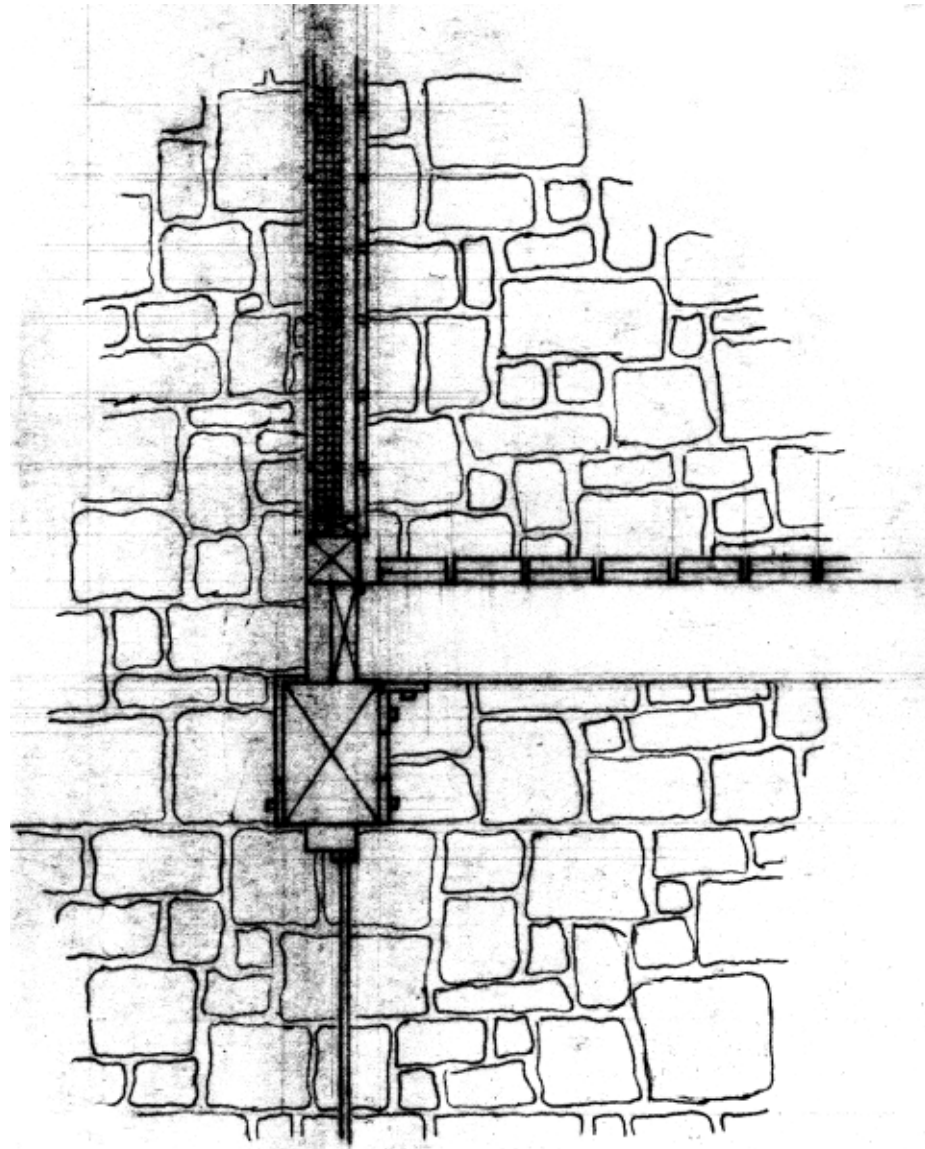

The steel element provides a transition from the stone to the wood, and accentuates the importance of each joint.

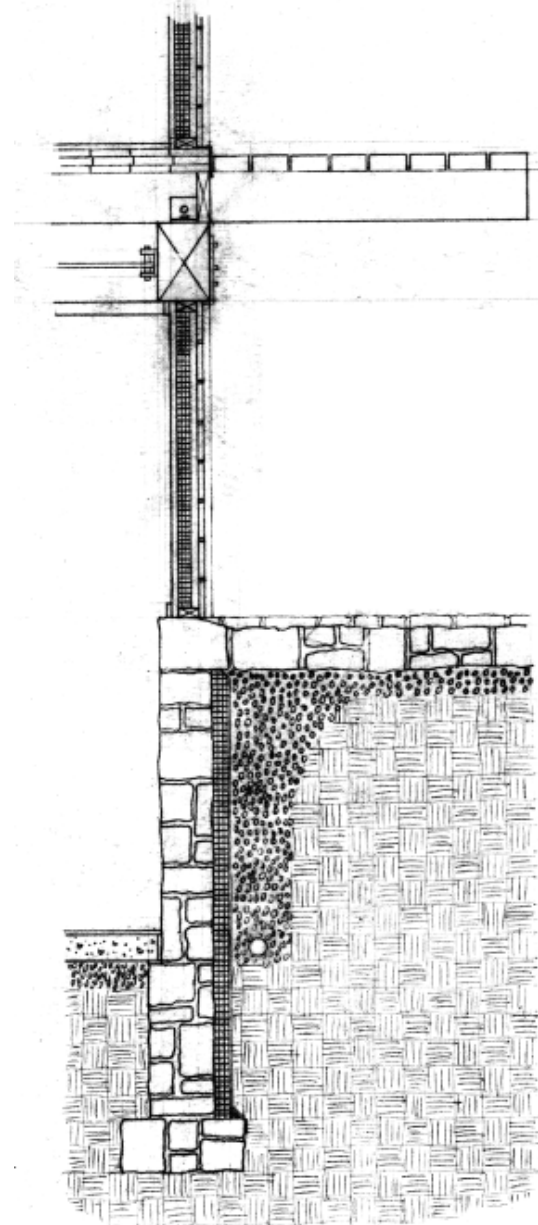

The stone wall is an extension of the ground and serves as the connection between the frame above and the earth below.

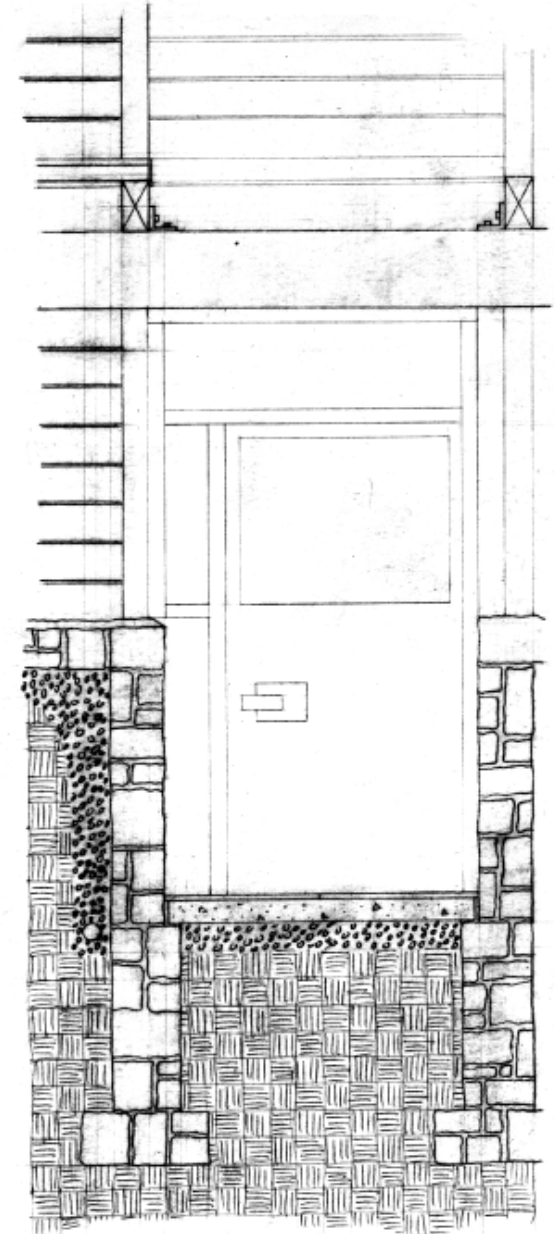

“Architecture is an art because it is interested not only in the original need for shelter but also in putting together spaces and materials in the meaningful manner. This occurs through formal and actual joints. The joint, that is the fertile detail, is the place where both the construction and the construing of architecture takes place.”

Marco Frascari

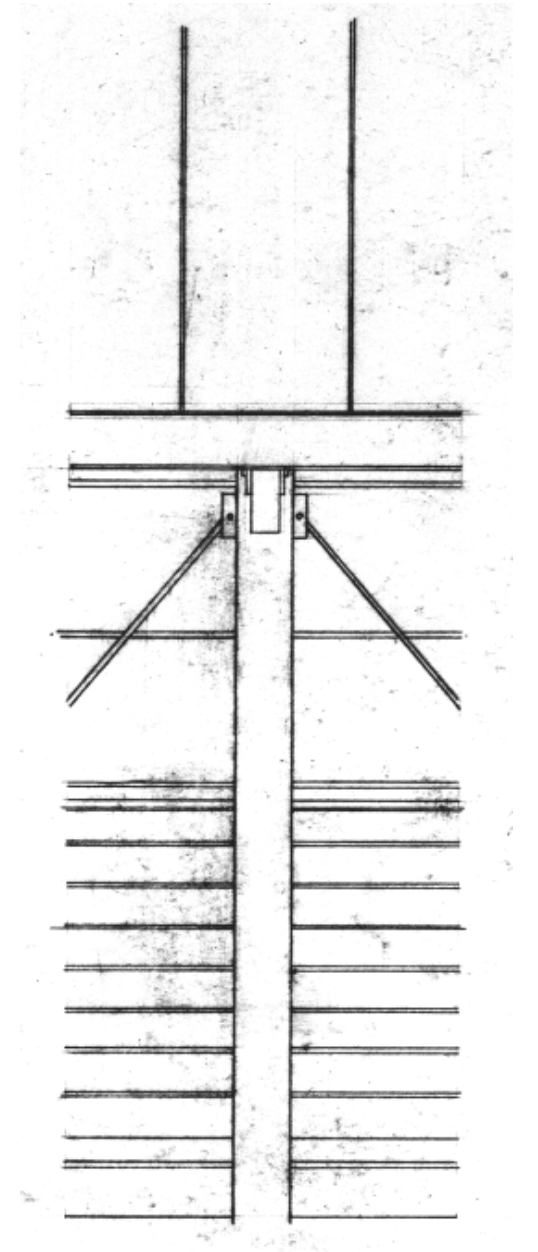
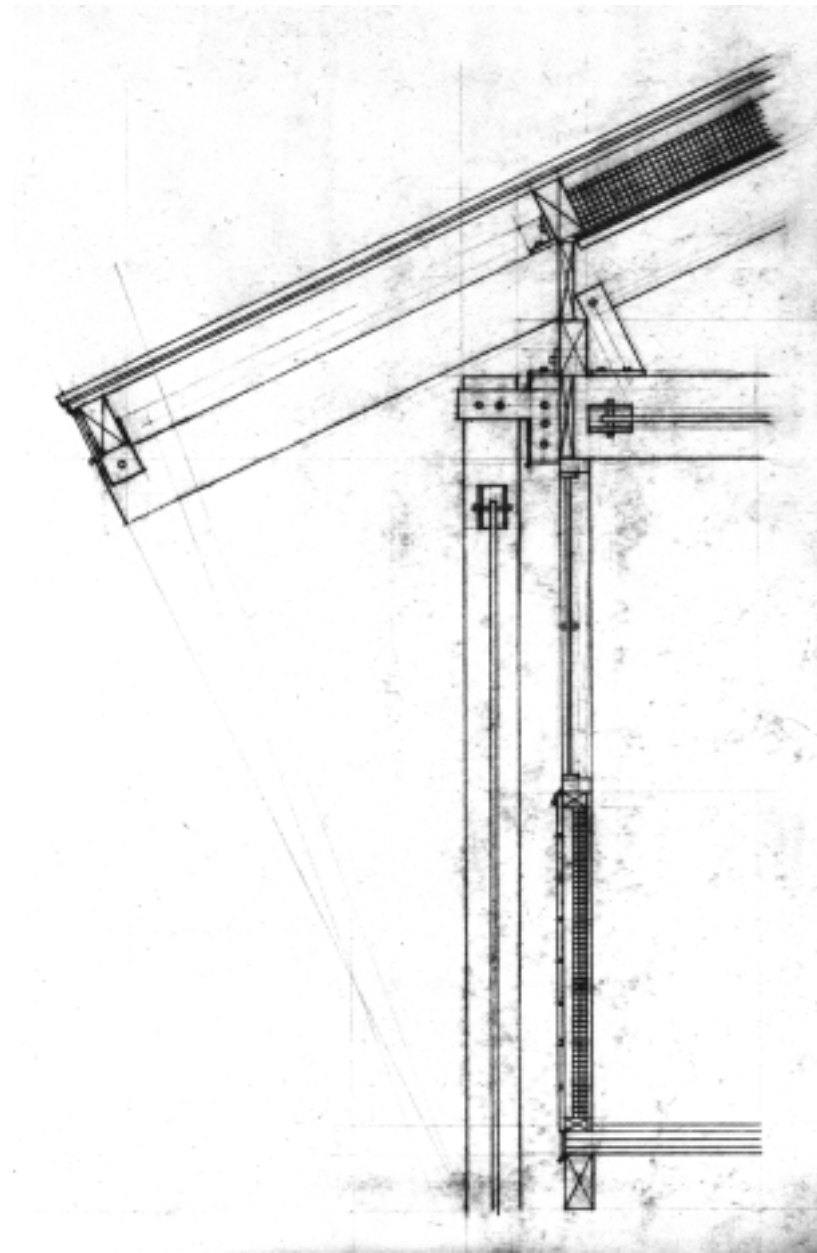

The column ends just short of the rafter, creating a space which shows the hierarchy of framing members at each connection.

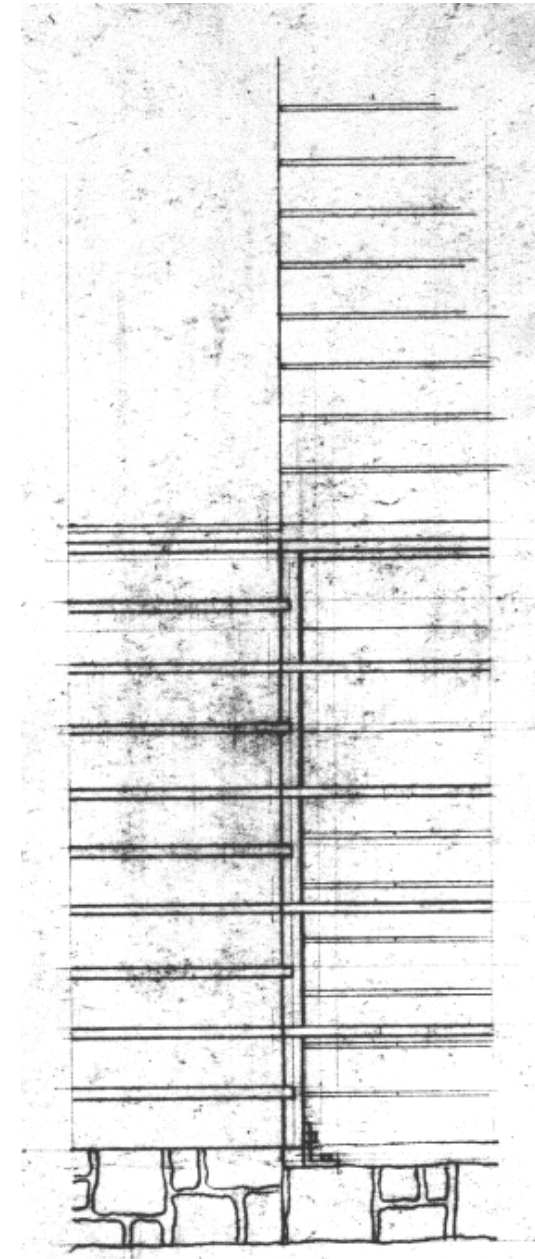
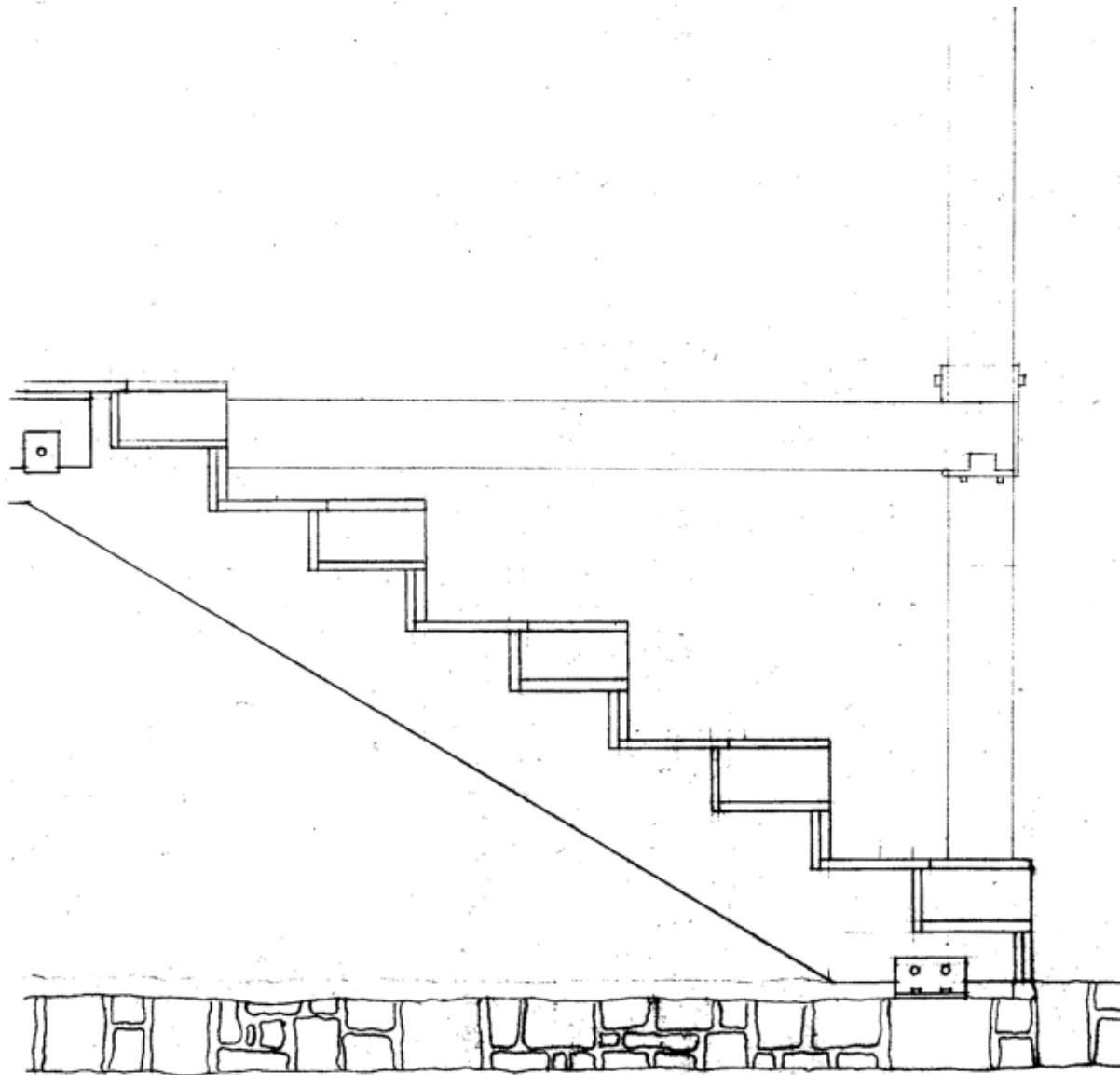

Detail of entry stairs. The smaller steps are for movement up and down, while the larger treads are for sitting and resting.

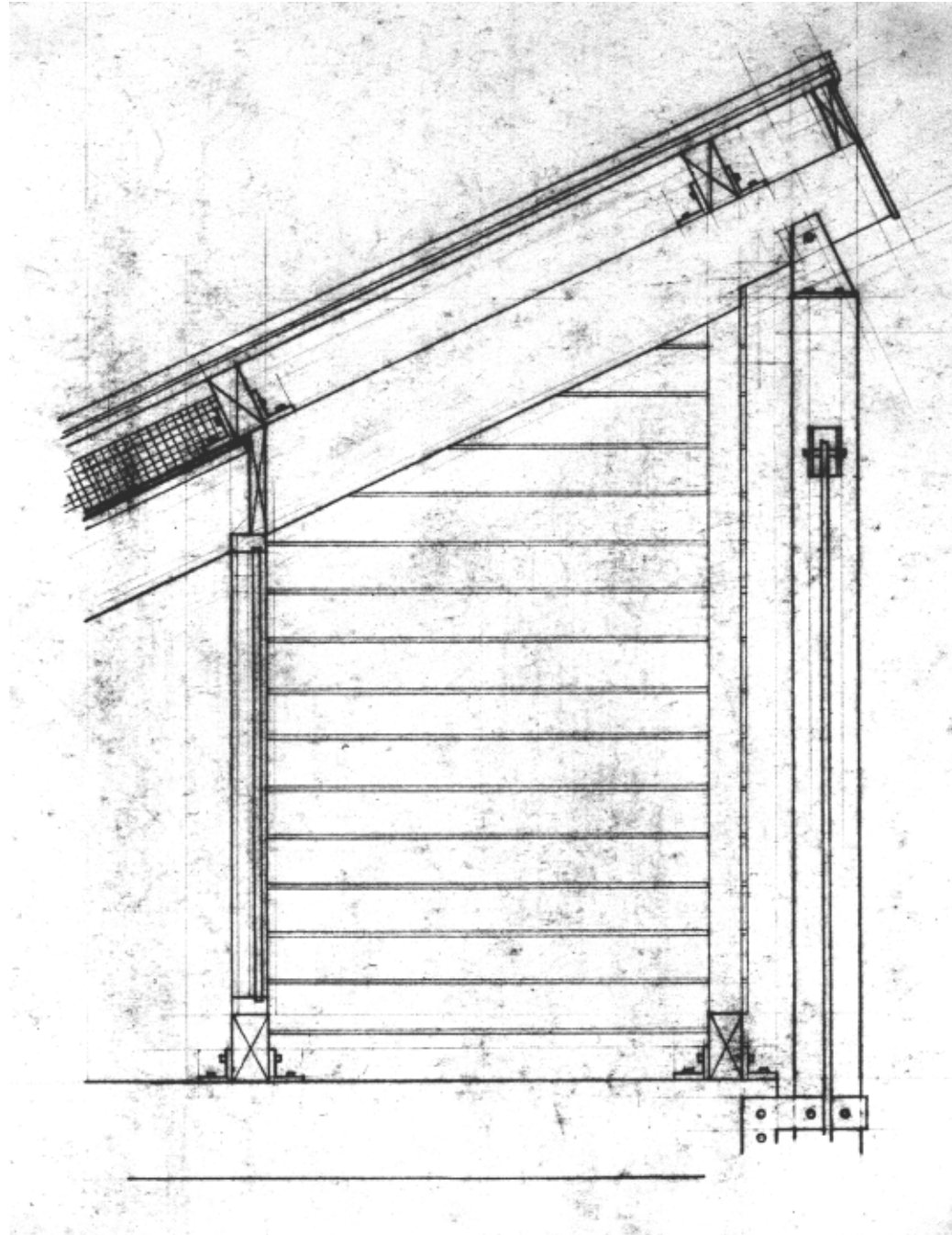

Studying how the building would be constructed further reinforced the importance of each connection. In order to keep the construction of the frame as simple and clean as possible, steel connectors were chosen as the means for fastening the wood timbers. They also provided a material contrast to that of the wood, thus emphasizing the joint even more. This hierarchy of materials, from the stone base, to the wood frame, and now the steel connection, gives a certain organization to the project, while allowing architecture to emerge at various scales.

The space between zones of structure and enclosure have broadened to allow for a zone of movement. The roof extends to cover this path, the transition between inside and out.



A hierarchy of girder and beam construction provides a repetition of connections, accentuating the linear nature of the building.



The frame moves from outside to inside, a direct response to the relation between a building and its site.



The cathedral ceiling allows the exposed connections and tension rods to invade the space without overwhelming it.

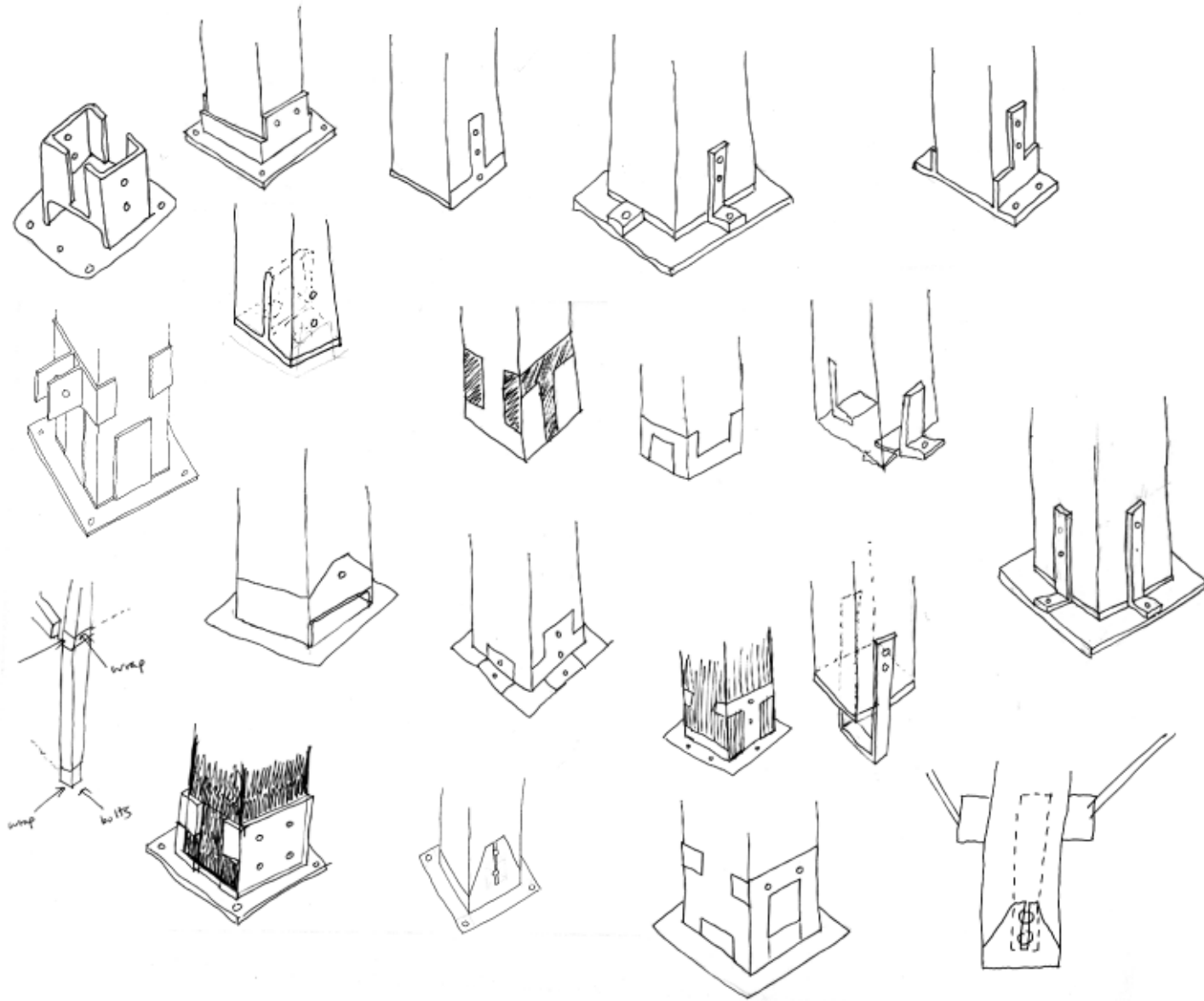

Three different connections were looked at in detail: where the column meets the base, where the beam meets the column, and where the column meets the rafter. These three connections represent the major points of structural integrity in the building. They become a visible part of the project, and were designed to demonstrate their function. Double plates in the column-to-base connection, for instance, prevent uplift in one direction, while adding stability in the other. This concept of visible function mimics Karl Bottsicher's definition of the tectonic. It involves a constructional element that is shaped so as to emphasize its static role and cultural status.

The exploration of steel bolts and plates as connectors.

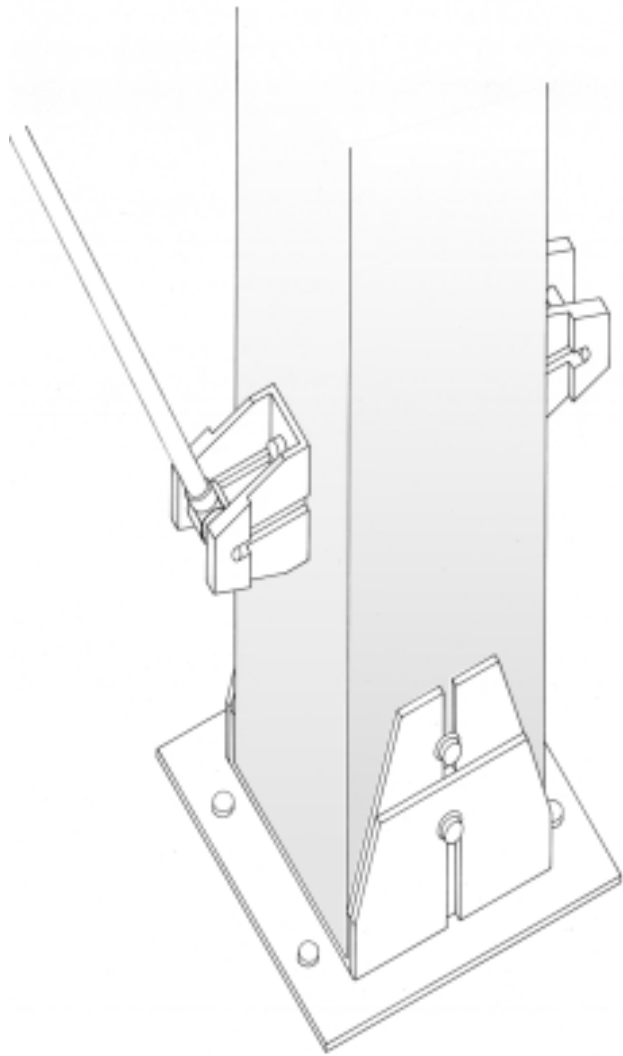

Column-Base Connection:
The double plate system allows functions to be separated, and the center slots aide in ease of construction.

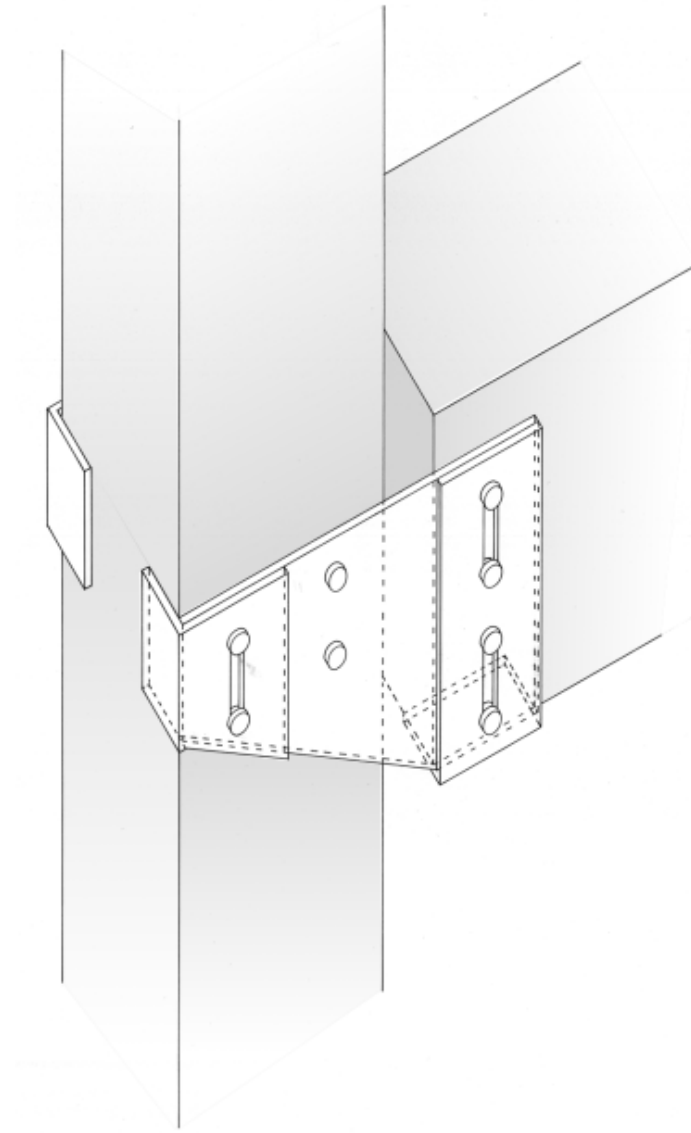

Column-Beam Connection:
One steel plate joins the pieces, while two others wrap the timbers to increase structural integrity.

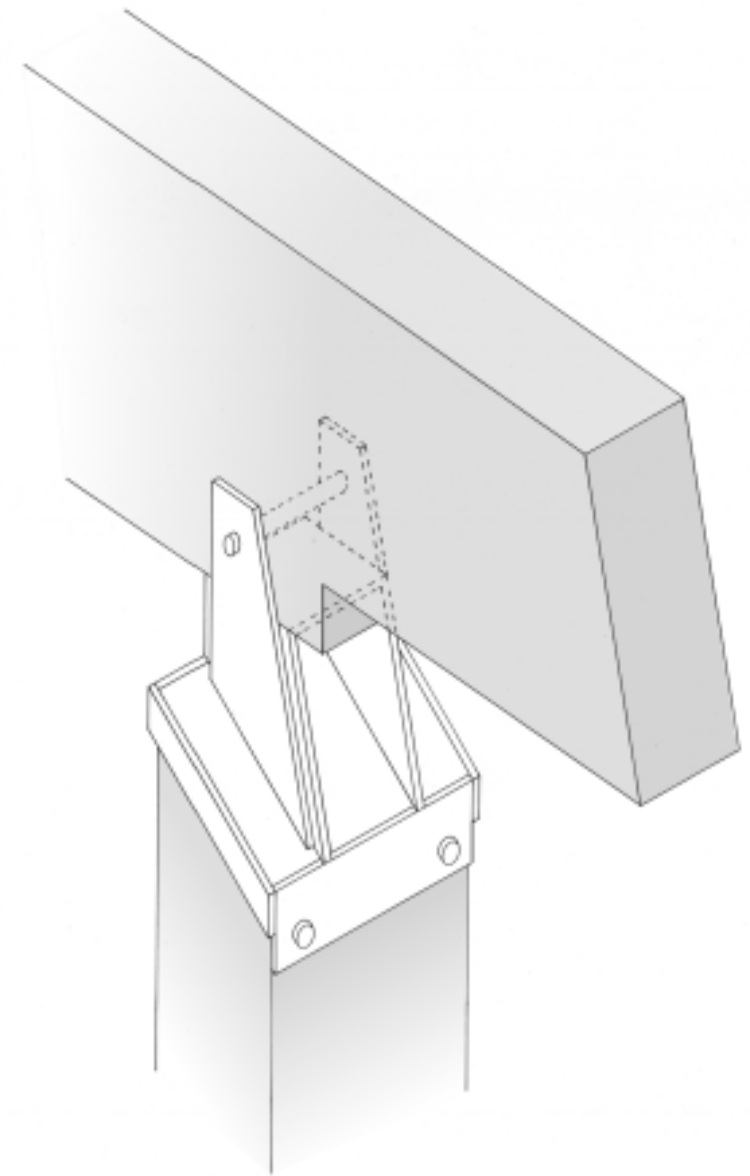

Column-Rafter Connection:
The interior portion provides a resting place for the rafter, while the exterior plates add lateral stability and prevent vertical movement.



infill (in-fil) n.

1. An amount needed to make full, complete, or satisfied.
2. Material for filling a container, cavity, or passage.

The enclosure of a building protects one from the elements of nature. Continuing with the features of the exposed structure, panels were placed within the grid to seal the building, while leaving the frame in full view. These infill panels have a direct correlation to the frame, and are constructed of the same material, wood, for framing and siding. In studying the connection between frame and infill, placement of windows and doors in the panel had a fundamental impact on how that relationship was perceived. The contrast of solid and void was also an influence. In certain situations, the infill panel, frame, and openings were independent of each other, while at other times each part required help from another to make a unit. This relationship was expanded when looking at how a number of panels would work together within the frame to create a whole.



The frame and the panel are separate entities, but together they create a singularity.



The placement of the door allows the frame to provide support, while the panel remains an independent piece.



The door is placed within the panel, and becomes dependent on it.



The window and panel are both supported by the frame, but not each other.



The window relies on both the frame and panel, while the panel relies only on itself.



The window and panel are separate but whole, each being drawn toward the corner by the frame.

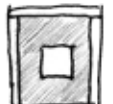

The window is a panel with a panel.



The window divides the panel in two. All three parts require interaction with the frame.



Three vertical panels, two solid and one transparent, combine to fill the void with dependency on the frame.



The windows interact with the entire frame, while the panel provides unsupported fill for the void.

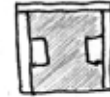

The panel reaches from top to bottom, and allows for window placement along the sides without impacting the frame.



The panel bridges the gap from one side to the other, allowing light to enter above and below.



The voids are spread to the edges of the frame, while the solid panel focus on the middle and the in-between.



The window provides a transition from the frame to the door, and still allows the panel to work around it.



The frame encloses the panel, which then encloses the door, separated only by thin strips of glass.



The door relies on the frame, and the window relies on the panel, but neither the frame nor the panel depend on each other.



The panel seems to defy gravity with the appearance of the window supporting it. It is really the frame that supports both pieces.



There can be no panel to fill a void, without beginning with just a frame.

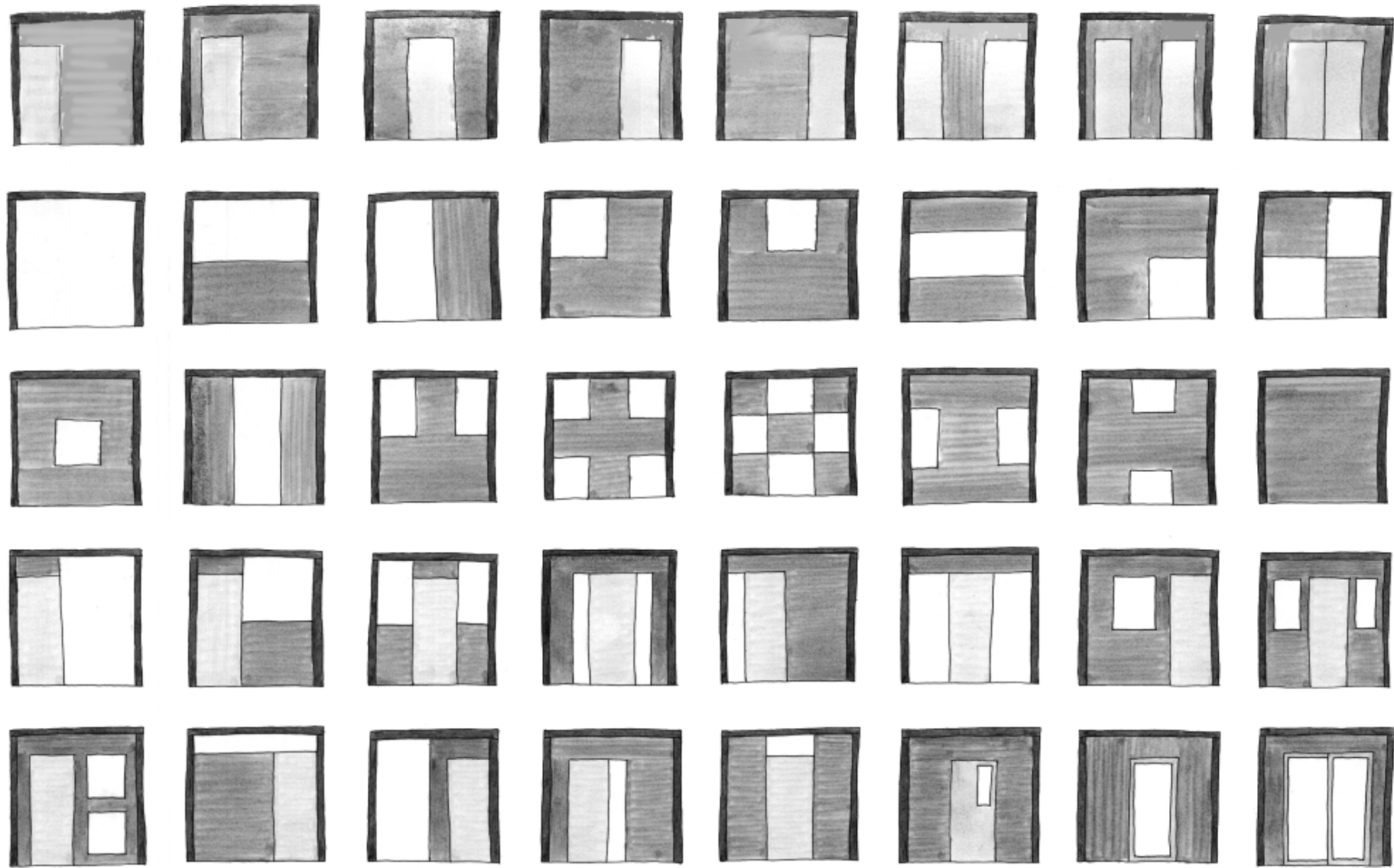

Initial study of the connection between frame and infill.

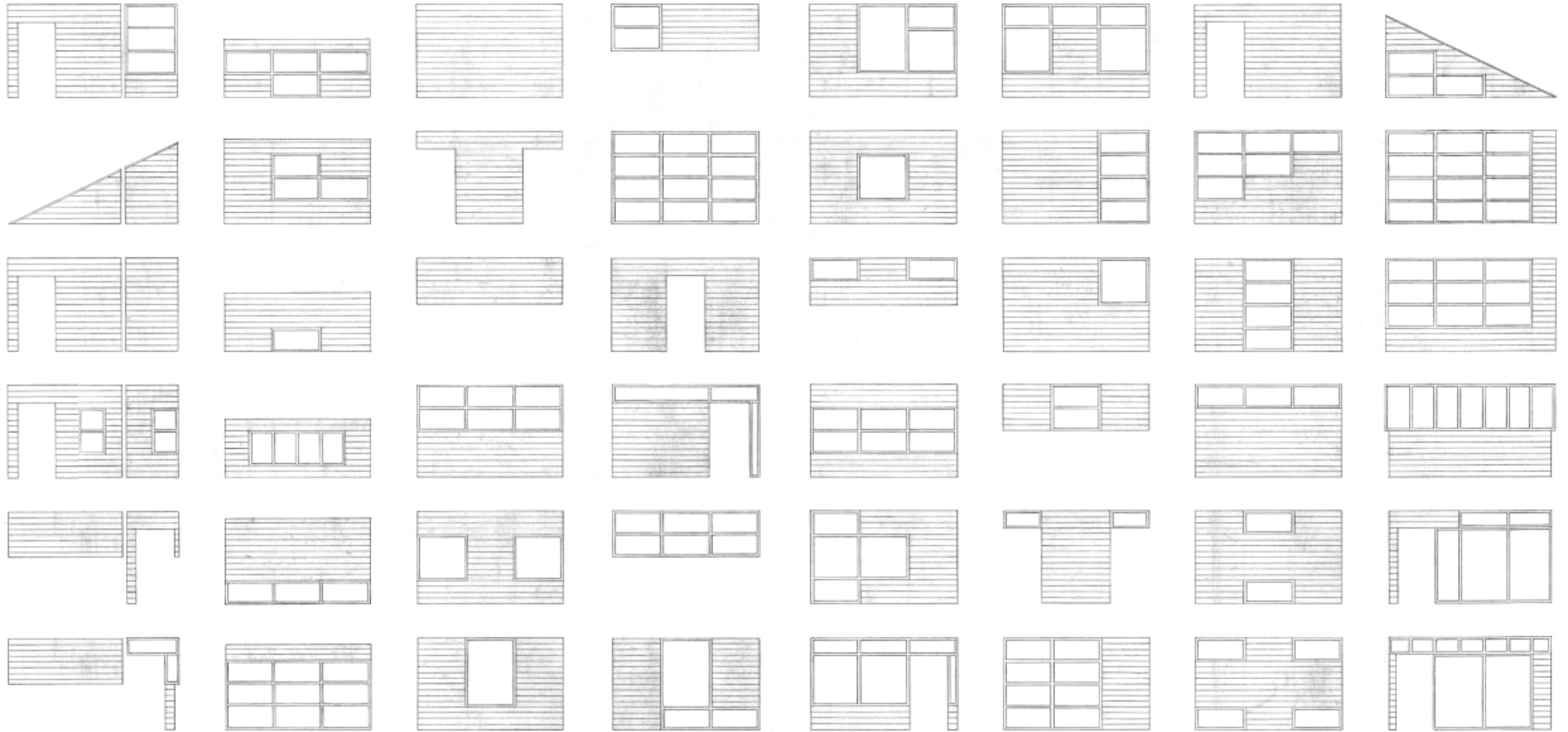

Study of window and door placement within a panel, taking into consideration the relationship between solid and void.

After generating numerous ideas on where an opening should occur, from a single window in the center of the panel, to windows in all four corners, two types of infill panels emerged to help limit the search. The first finds the panel touching all sides of the frame, while the opening is located completely within the frame. The second finds the opening touching the frame in at least one place. In order to keep a one-to-one relationship between the frame and infill, windows that divided the panel into two were eliminated.

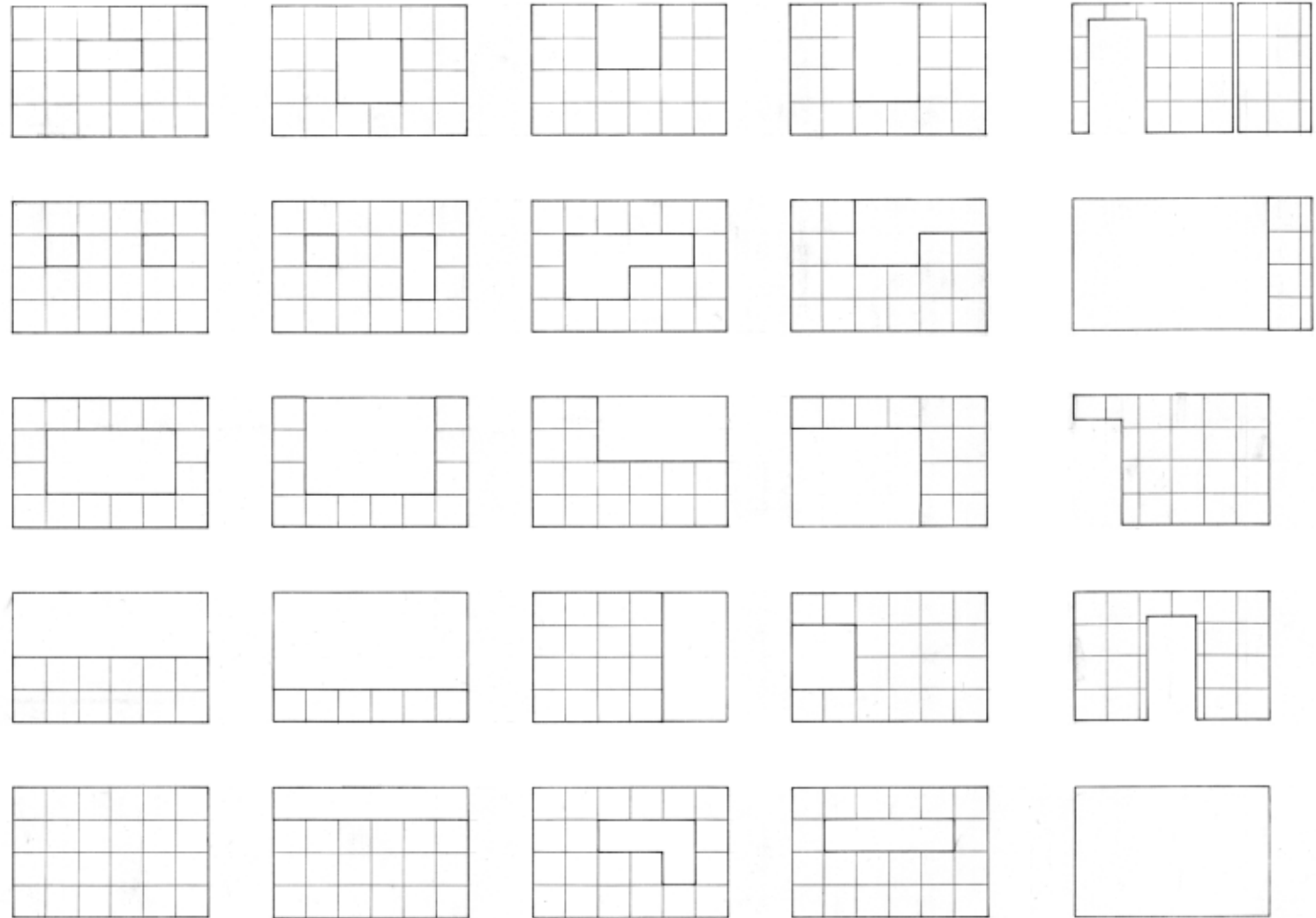

A second iteration of this panel study generated necessary rules to limit the almost endless placement of openings. One type of panel features openings entirely within the panel, while the other places openings at one edge of a panel, in contact with the frame.

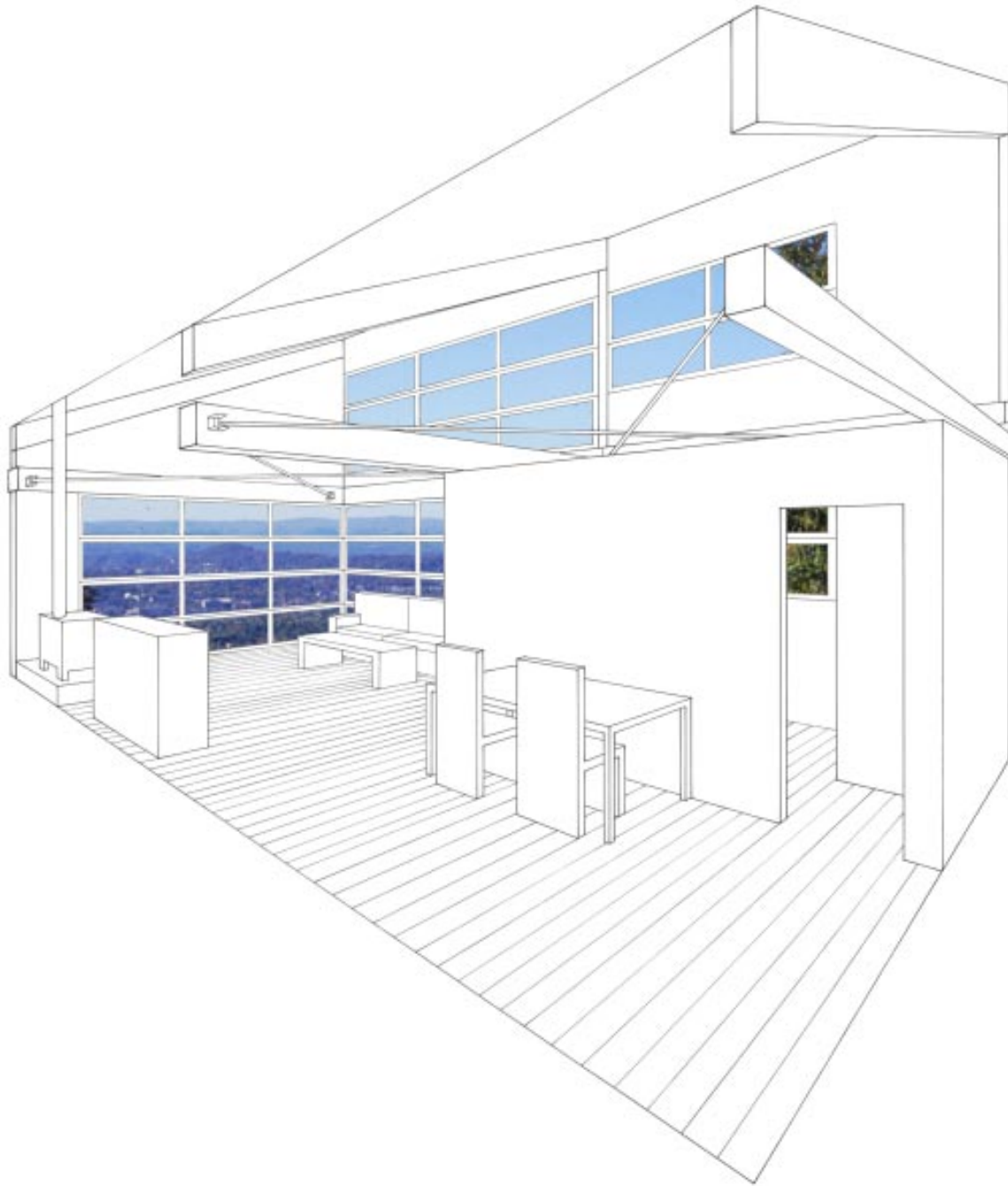

These rules were further impacted by basing window placement on what happens on the inside. It was important to have enough windows to allow ample views of the site, strengthening the relationship with nature. The location of these openings varied with their function. For example, small windows in the hallway of the ranger's quarters give glimpses of the site, while providing privacy as well. At the other extreme, an entire panel of windows in the living area offers a generous view overlooking the valley. Creating views within the frame allows the beauty of nature to influence the architecture of the space.



Window placement has a dramatic impact on the light in a space and the presentation of views outside. The various sizes and locations of openings in the panels were also studied from the inside to find the appropriate combination.

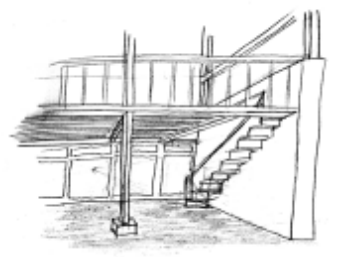
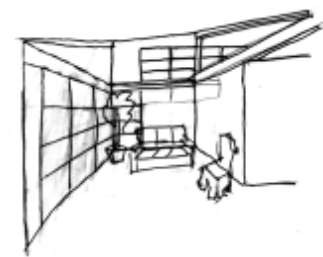
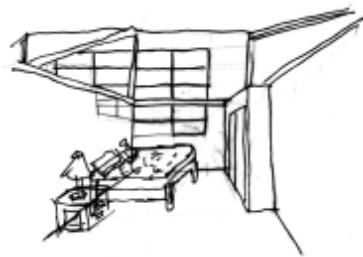

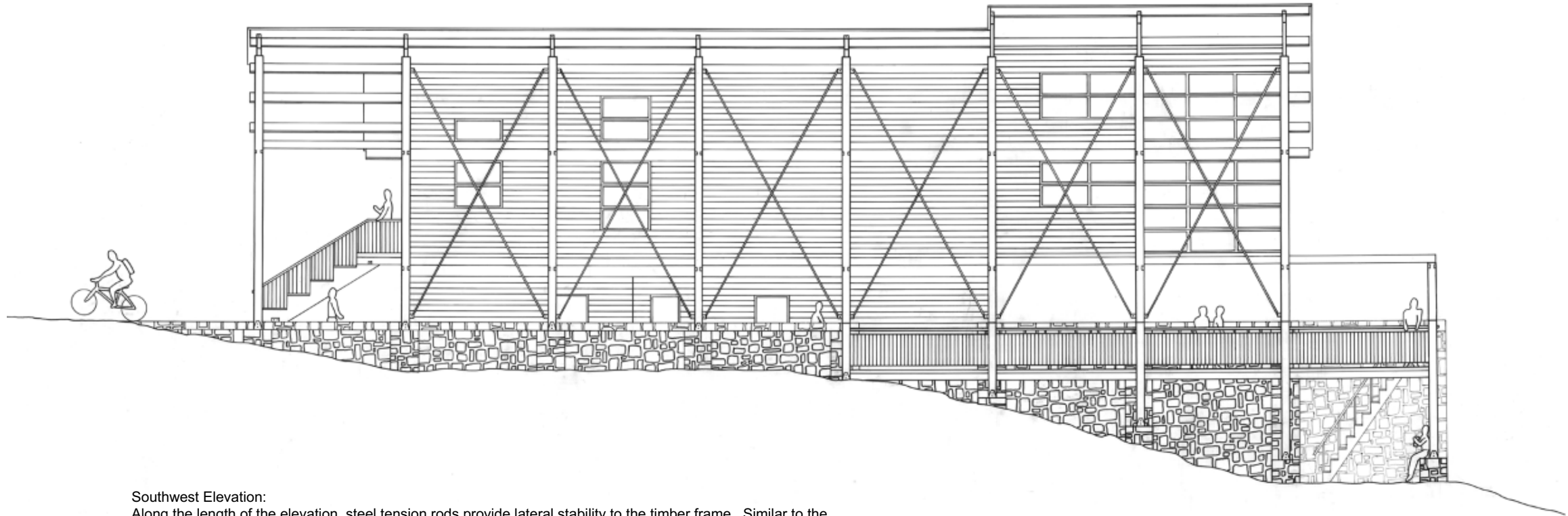

31

Southwest Elevation:
Along the length of the elevation, steel tension rods provide lateral stability to the timber frame. Similar to the steel connectors at each joint, these steel rods enable the wood frame to keep its clean design, without losing any structural integrity.

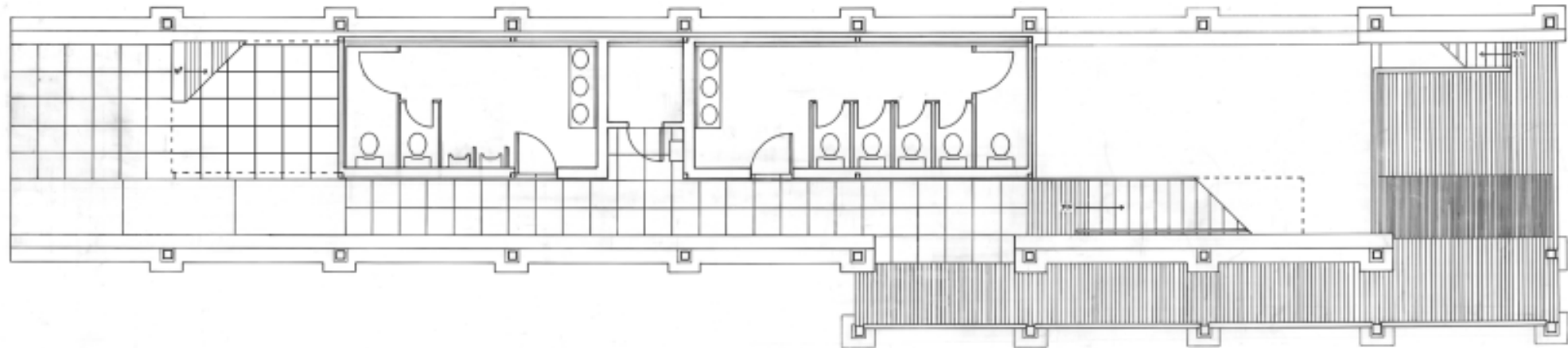

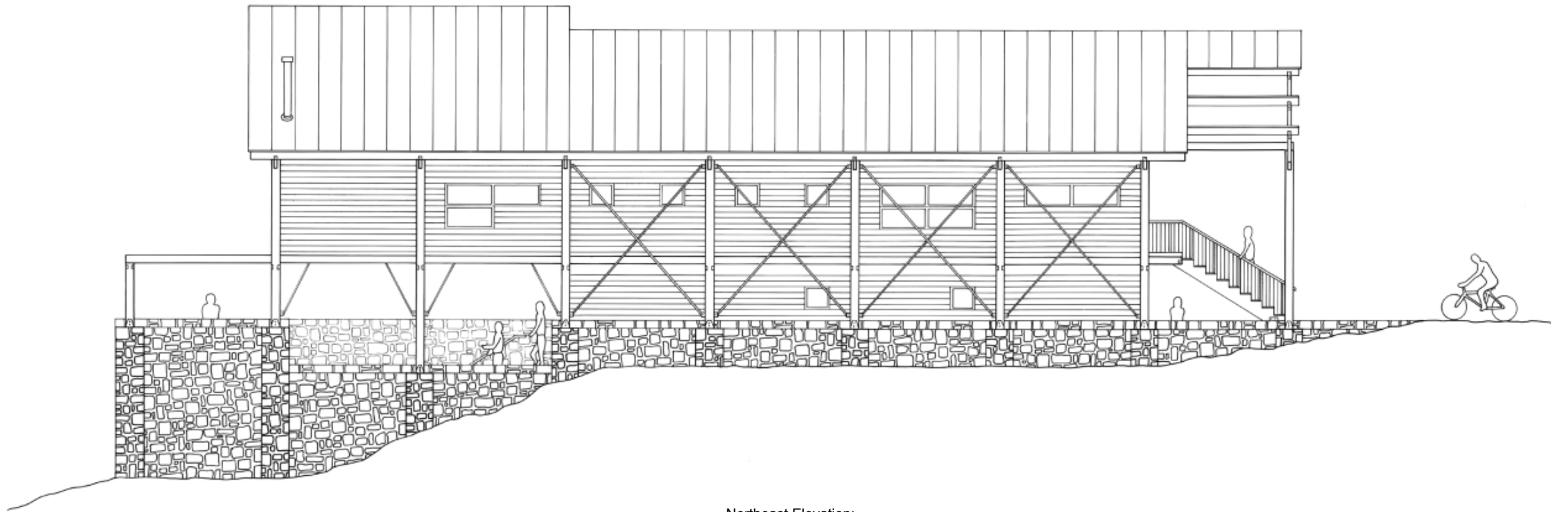

Northeast Elevation:
The variety of windows in the elevation gives each panel a unique character, while the columns and tension rods unify the panel system into a single facade.

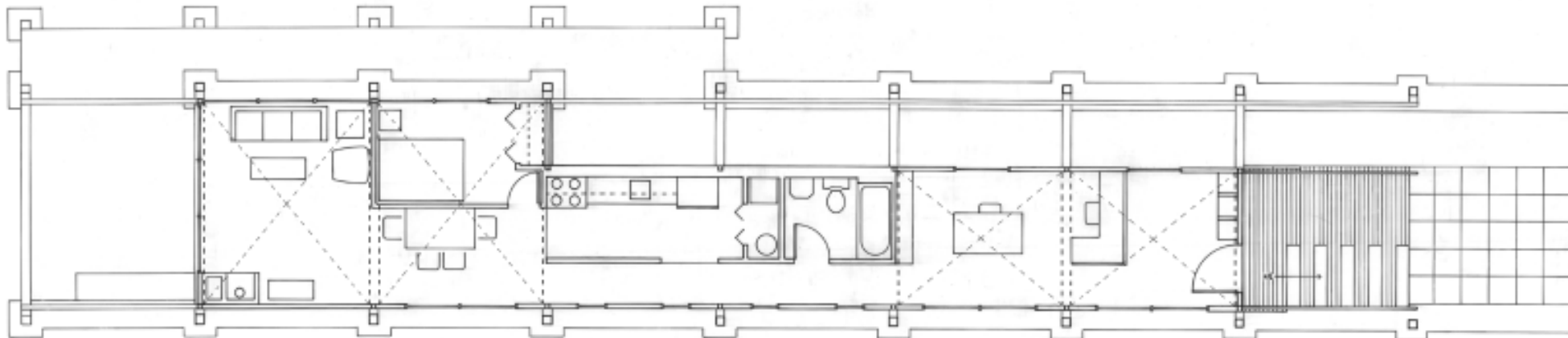

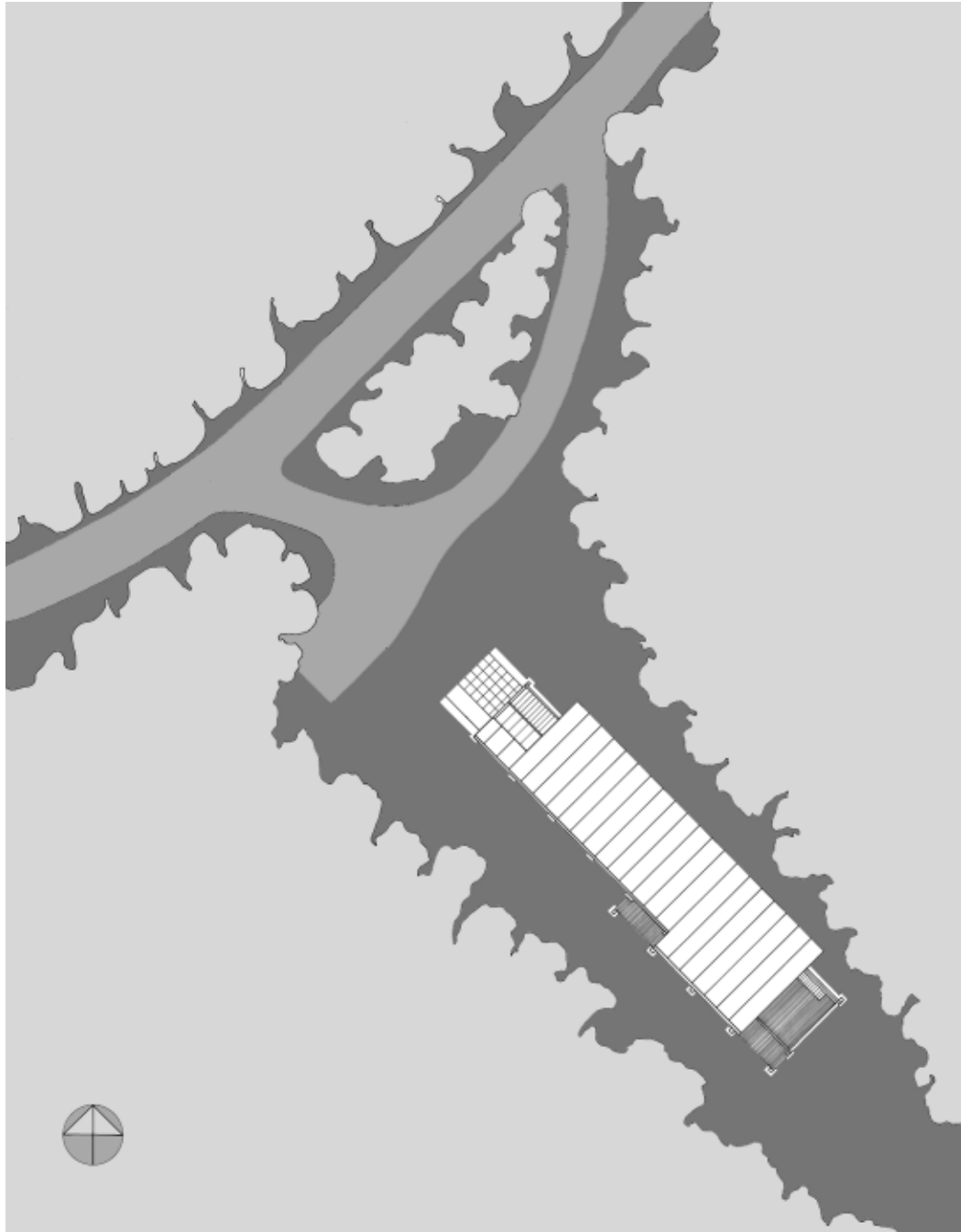

path (pāth) n.

1. A trodden track or way.
2. The route or course along which something travels or moves.
3. A course of action or conduct.

All of the previous architectural elements discussed, the base, frame, connection, and infill, combine to create a building which acts as a path. Just as one walks up the mountainous trail to reach the summit, when he or she arrives at the site a new path begins. As the generator and organizer of the place, the path becomes a link between the building and its context. The stone patio comes out of the earth and offers a choice to begin the journey: up the stairs to the ranger's office, or down the ramp toward view. The frame and roof extend from the bulk of the structure to provide shelter for the path, and invite one to enter. The single roof line helps to enforce the linear quality of the structure and its path.

One begins to understand the project as a whole and its relation to its environment as they start to proceed through the space. As one moves along the walkway, located to the southwest of the building, the frame and its connections are revealed in great detail. This repetition of elements accentuates the path and the constant view of the horizon draws one toward the end of the structure. Before reaching the end, one moves down a set of stairs into a covered gathering space. It is in this two-story space, cut into the earth, that one experiences the mass of the stone walls that bear the load of the project. Emerging from this space, one reaches the end, and the view of the valley is offered as a reward for taking a path in architecture.

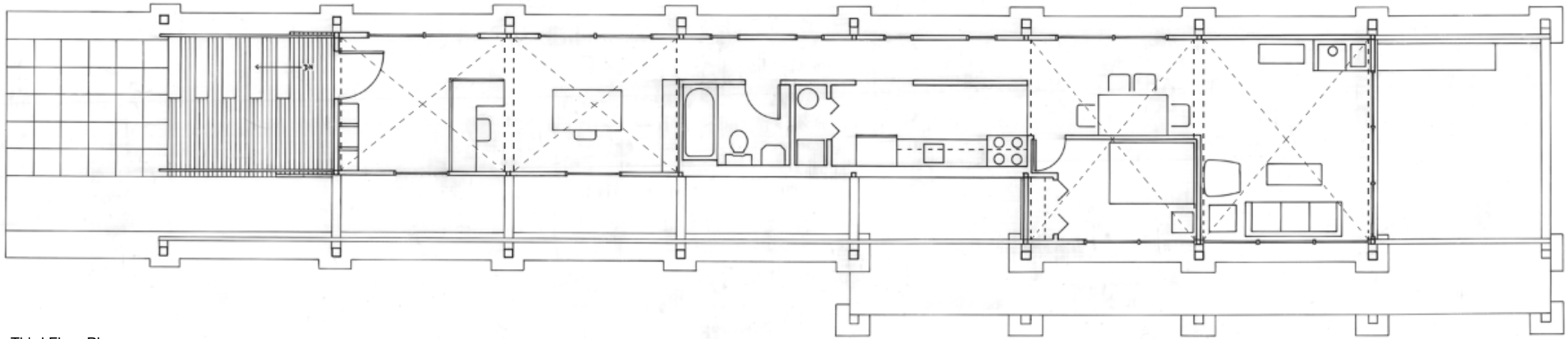

Third Floor Plan:

The path begins up a set of steps, passes through the ranger's office, down a narrow hallway, and opens up into the living area, which overlooks the valley. A clear zone of movement is needed to convey the building as a path.

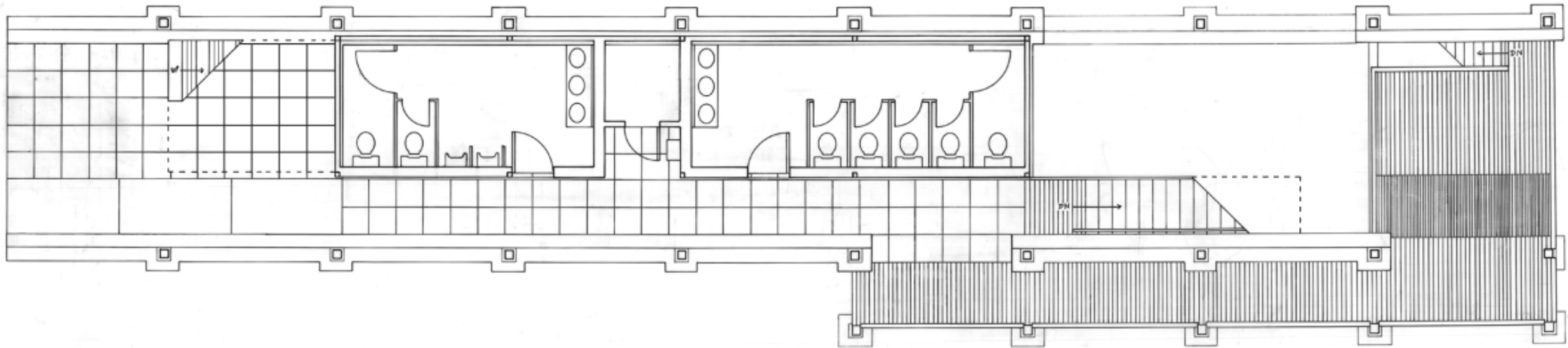

Second Floor Plan:

The path follows the length of the stone wall from one end to the other. Taking the interior route leads down a set of steps to the ground level, while taking the exterior route leads to a wooden deck looking down the mountain.

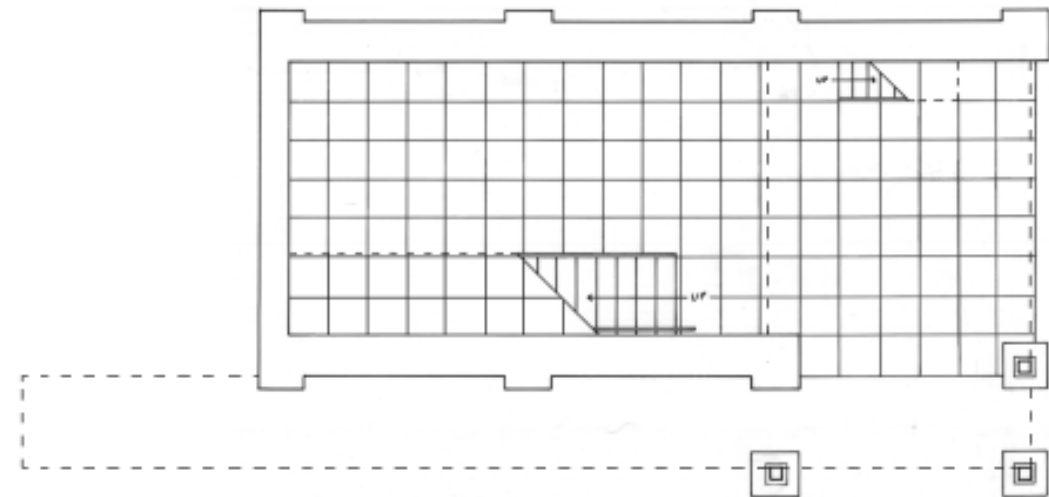

Ground Floor Plan

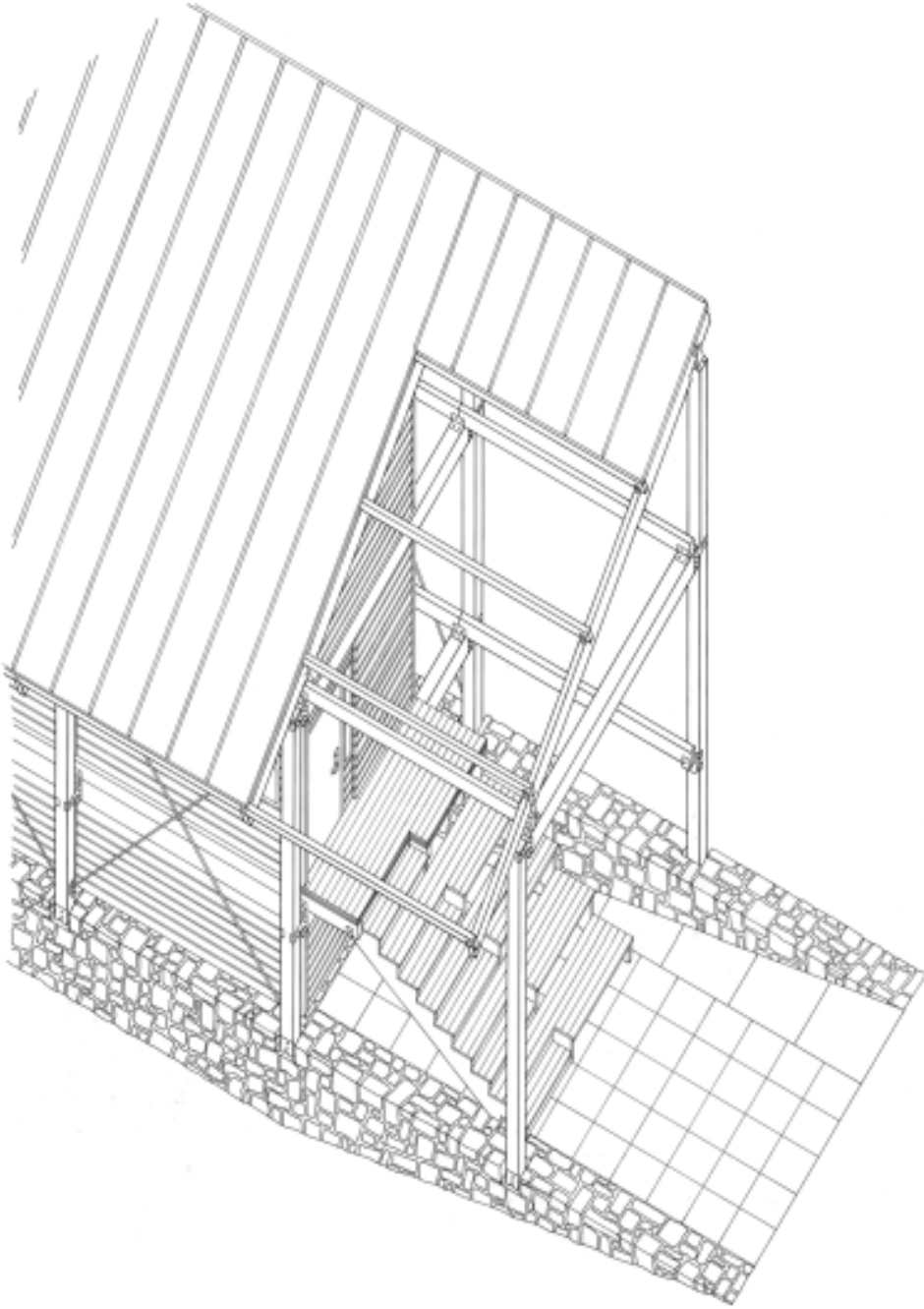

Every path has a beginning, middle, and end. It is important to differentiate these experiences in architecture by varying materials, light conditions, or spatial limits. The beginning of the path is characterized by the open timber frame soaring above one's head and the stone wall that slowly rises up from the ground at one's feet. The wall signifies the start of a path and the interaction of the frame and base continue to strengthen this path along the exterior of the building.

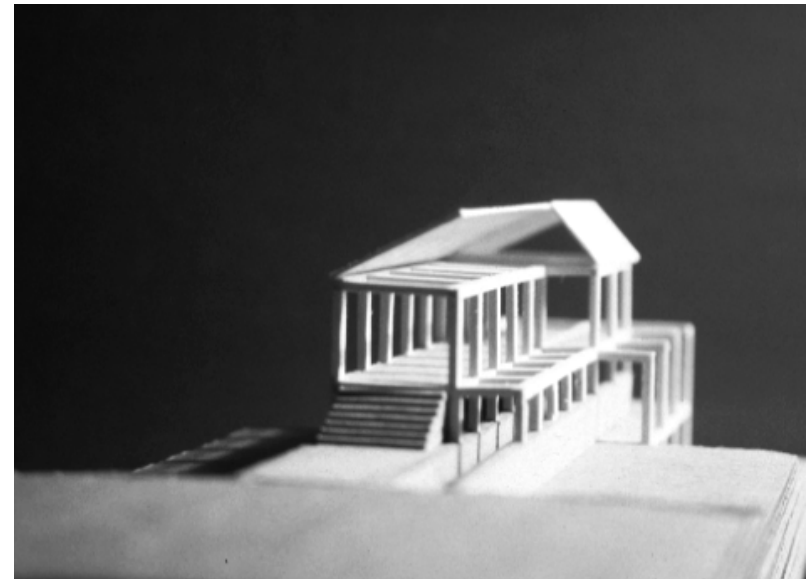
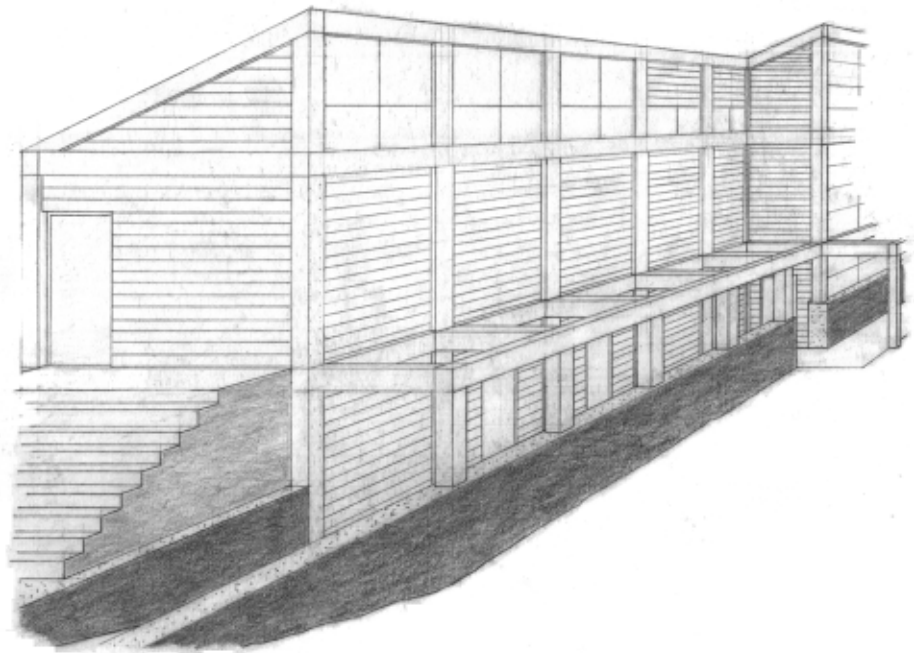





The middle of the path exposes one to the separation of structure and enclosure.



On the interior, the use of light helps to delineate the path as one proceeds down to the ground level and the gathering space.



The path on the ground level is echoed above with a change in decking material that lets light filter through.

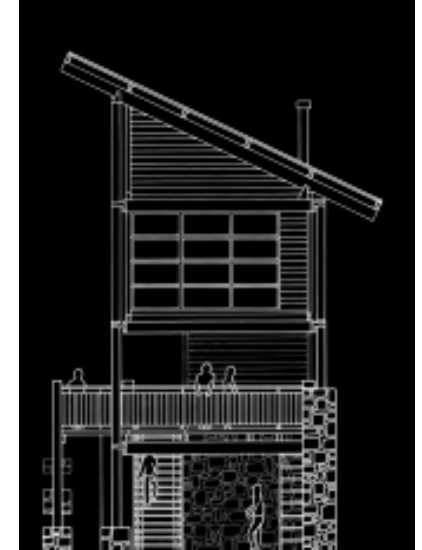

The path wraps around the end of the project in the form of a deck and presents the beautiful view of nature, while marking the end of one's journey.



a p p e n d i x

base

(left to right, from top to bottom)

Lake/Flato: Chandler Ranch
Peter Bohlin and James Cutler: Guest House
Greene and Greene: Rossem House
Existing cabin on Brush Mountain

James Cutler: Virginia Merrill Bloedel Education Center
Bohlin Cywinski Jackson: House in the Adirondacks
Xavier Gruell: Ca l'Agusti House
Alfred Caldwell: Sun House

Franceso Rius: Rius Fina House
Wood Cabin in Cascades Recreation Area
Peter L. Gluck: Addition to Usonian House
Josep Maria Sostres: Marti Campanya House

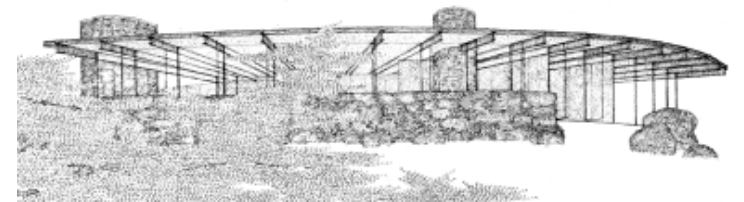

frame

(left to right, from top to bottom)

Rebecca L. Binder: Information Computer Sciences/Engineering Research Facility Phase III

Auguste Perret: Beton Arme, Acier et Bois

Peter L. Gluck: Linear House

Bohlin Cywinski Jackson: Weekend House

Bohlin Cywinski Jackson: Biotechnology Center, University of Pittsburgh

Peter Bohlin and James Cutler: Guest House

James Cutler: Virginia Merrill Bloedel Education Center

Peter L. Gluck: Linear House

James Cutler: Swimming Pool

Bohlin Cywinski Jackson: House in the Adirondacks

Joseph Paxton and Charles Fox: Crystal Palace

Covered Bridge, Newport VA

James Cutler: Swimming Pool

Bohlin Cywinski Jackson: Irving Avenue Garage, Syracuse University

Greene and Greene: Gamble House

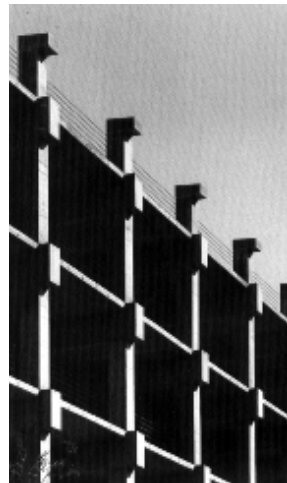
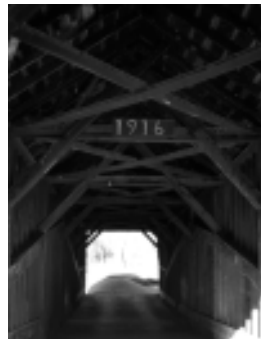
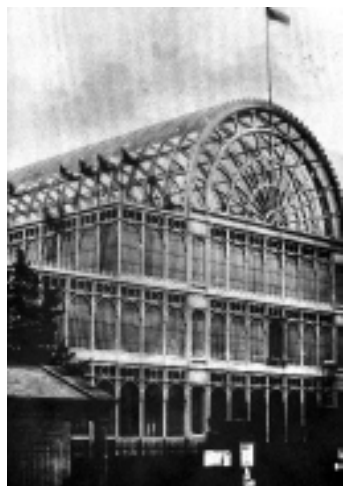
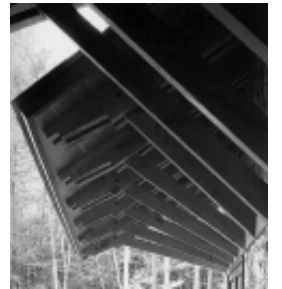
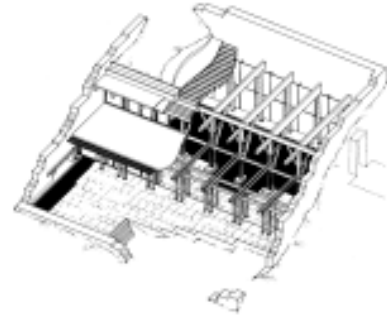
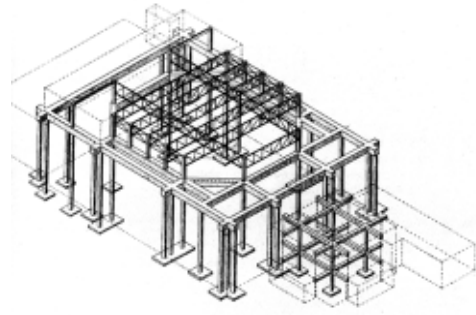

connection

(left to right, from top to bottom)

Rebecca L. Binder: Information Computer Sciences/Engineering Research Facility Phase III
Peter Bohlin and James Cutler: Guest House
Peter Bohlin and James Cutler: Guest House
James Cutler: Swimming Pool
Bohlin Cywinski Jackson: Weekend House
Peter Bohlin and James Cutler: Guest House

Lake/Flato: Burlington Northern Santa Fe
Lake/Flato: Burlington Northern Santa Fe
James Cutler: Virginia Merrill Bloedel Education Center
Peter Bohlin and James Cutler: Guest House
Existing connection, Cabin on Brush Mountain

James Cutler: Swimming Pool
Greene and Greene: Gamble House
Henry Hawthorne: Forest Engineering Research Institute of Canada
Covered Bridge, Newport VA
Peter L. Gluck: Bridge House

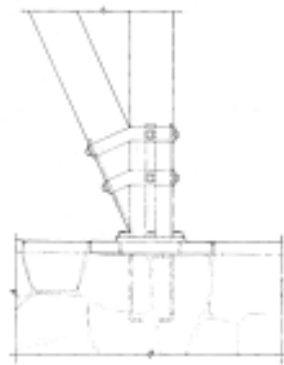
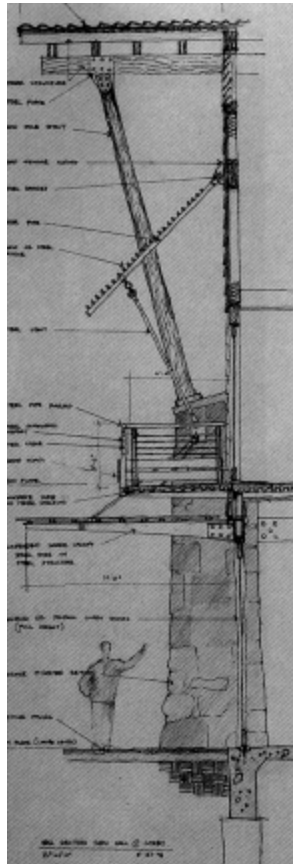
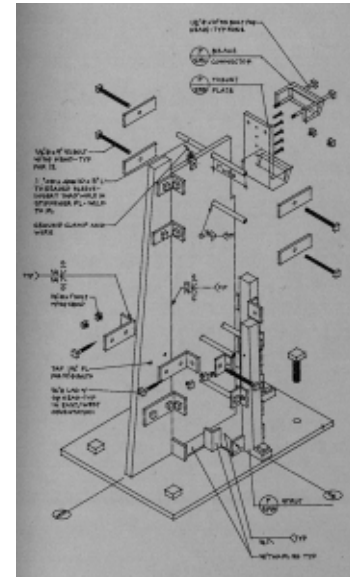
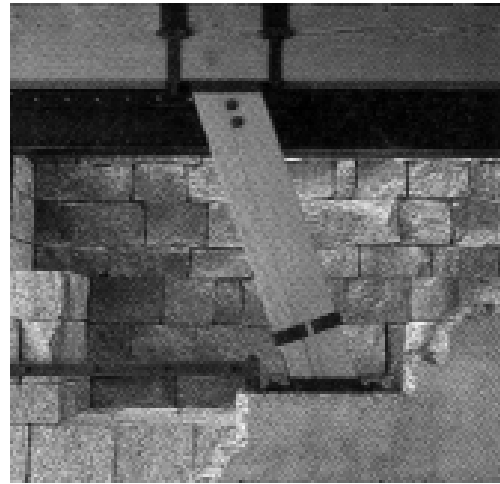

infill

(left to right, from top to bottom)

Louis I. Kahn: Yale Center for British Art
Peter L. Gluck: Linear House
Derring Hall, Virginia Tech
Auguste Perret: Villa de M. Mela Muter
Louis I. Kahn: Yale Center for British Art

Auguste Perret: Batiment du Service Technique des Constructions Navales
Giuseppe Terrangi: La Case del Fascia
Whittemore Hall, Virginia Tech
Henry Hawthorne: Forest Engineering Research Institute of Canada

Peter L. Gluck: Linear House
Louis I. Kahn: Yale Center for British Art
Giuseppe Terrangi: La Case del Fascia
Lake/Flato: Burlington Northern Santa Fe

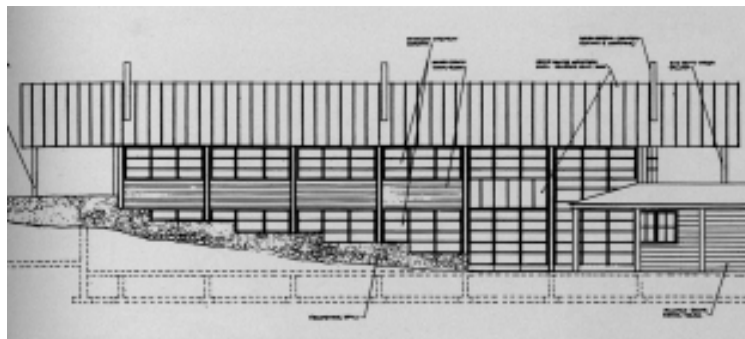
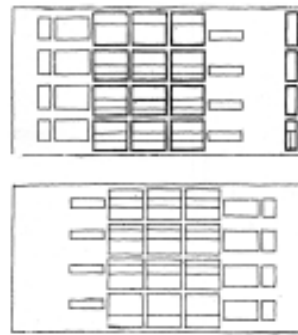

path

(left to right, from top to bottom)

Bohlin Cywinski Jackson: Bohlin Summer House

Lake/Flato: La Estrella Ranch

Peter L. Gluck: Bridge House

Francisco Ribas and Jose Luis Cia: Taberner House

Peter Bohlin and James Cutler: Guest House

James Cutler: Swimming Pool

James Cutler: Wright Guest House

James Cutler: Paulk Residence

Bohlin Cywinski Jackson: Pennsylvania Higher Education Assistance Agency

Peter L. Gluck: Linear House

Mario Botta: La Cappella del Monte Tamaro

Peter Bohlin and James Cutler: Guest House

Peter L. Gluck: Manor House with Music

Bohlin Cywinski Jackson: Bohlin Summer House

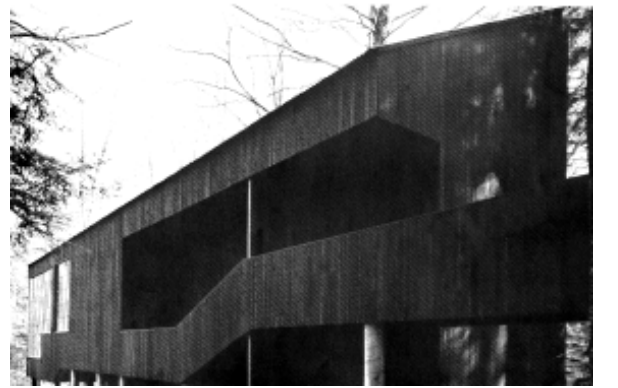

b i b l i o g r a p h y

Blaser, Werner. Architecture and Nature: The Work of Alfred Caldwell. Birkhauser Verlag: Basel. 1984.

Bohlin Cywinski Jackson. The Architecture of Bohlin Cywinski Jackson. Rockport Publishers: Gloucester, Mass. 1994.

"Bohlin Powell Larkin Cywinski." GA Houses. Vol. 9. 1981.

Bosley, Edward R. Gamble House. Phaidon Press: London. 1992.

Cucchi, Enzo. Mario Botta: La Cappella del Monte Tamaro. Umberto Allemandi & C.: Torino. 1994.

De Long, David G. and Brownlee, David B. Louis I. Kahn: In the Realm of Architecture. Rizzoli: New York. 1991.

Frampton, Kenneth. "Rappel a L'ordre: The Case for the Tectonic." Architectural Design. Vol. 60, no. 3-4. 1990.

Frascari, Marco. "The Tell-The-Tale Detail." VIA. No. 7. 1984.

Gargiani, Roberto and Fanelli, Giovanni. Perret E Le Corbusier Confronti. Laterza: Rome. 1990.

Gregotti, Vittorio. "Lecture at the New York Architectural League." Section A. Vol. 1, no. 1. March, 1983.

Harriman, Marc S. "Engineering Nature." Architecture. Vol. 80, no. 9. September, 1991.

Kahn, Louis I. Louis I. Kahn. A+U Publishing: Tokyo. 1975.

Makinson, Randell L. Greene and Greene. Peregrine Smith: Salt Lake City, Utah. 1977.

McKean, John. Crystal Palace: Joseph Paxton and Charles Fox. Phaidon Press: London. 1994.

Morrow, Theresa. James Cutler. Rockport Publishers: Gloucester, Mass. 1997.

Nesmith, Eleanor Lynn. Rebecca L. Binder. Rockport Publishers: Gloucester, Mass. 1995.

Ojeda, Oscar Riera. Lake / Flato. Rockport Publishers: Gloucester, Mass. 1996.

Ojeda, Oscar Riera. Ten Houses: Peter L. Gluck and Partners. Rockport Publishers: Gloucester, Mass. 1997.

Pastore, D. and Ferrario, L. Giuseppe Terragni--La Casa del Fascia. Instituto MIDES: Rome. 1982.

Perret: une Etude de Pierre Vago sur L'oeuvre Complete d' A.G. Perret. L'Architecture d'Aujourd'hui: Paris. 1991.

Rosella, Monica and Puid, Ramon M. Mountain Houses. Gustavo Gill: Barcelona. 1991.

Semper, Gottfried. The Four Elements of Architecture. Cambridge University Press: Cambridge. 1989.

v i t a

Colin J. Smith

November 21, 1974

Master of Architecture

Virginia Polytechnic Institute and State University
Blacksburg, Virginia
July 1999

Bachelor of Arts in Architecture

Lehigh University
Bethlehem, Pennsylvania
June 1996