

## **PAINTERLY CONCEPTION OF ARCHITECTURE**

### **Maiss Razem**

Thesis submitted to the faculty of Virginia Polytechnic Institute and State University in partial fulfillment of the requirements for the degree Master of Architecture in the year 2005. Thesis defense took place on 20th of July/2005 at the city of Blacksburg in the state of Virginia.

---

Committee Chairman, William Galloway

---

Committee Member, Hans Rott

---

Committee Member, Steven Thompson

## **ABSTRACT**

The art of painting opens vast expressive possibilities for architecture, wherein architecture can produce a more conducive atmosphere for the contemplation of painting. The subtle affinities between the two fields stirred me to explore the individualistic expressiveness of the sensory realm in a painting and how it can inspire an architect.

My thesis starts from an interest in a painting of Kandinsky's. The painting 'Yellow, Red, Blue' stirred my curiosity in the potency of its beauty and made me ask questions in regards to what I can capture, learn and express architecturally. The aim is to design a Contemporary Art Center to be situated within the fabric of Virginia Tech campus.

Throughout the various stages of design, the finality of the project resulted from dealing with the various inputs from: Kandinsky's painting as a catalyst and inspirer to the design, to the contextual issues and ways of urban integration and also dealing with the nature of the project's function and programmatic needs.

## TABLE OF CONTENTS

'YELLOW, RED, BLUE'	2
FORMAL EXPLORATION	4
REFLECTIONS	8
THE SITE	10
EARLY ITERATIONS:	12
INTERSECTING VOLUMES	16
STRUCTURAL ASSEMBLY	17
CIRCULATION	18
COLOR	19
BACKGROUND TO FOREGROUND RELATIONS	20
DRAMA OF LIGHT	24
FINAL THOUGHTS	41
BIBLIOGRAPHY	42
ACKNOWLEDGEMENTS	43

## **‘YELLOW, RED, BLUE’**

‘Yellow, Red, Blue’ presented me with many challenges for interpretation. I tried to find ways of analyzing the structural qualities of the painting dealing with the different layers represented. I started by differentiating color, proportion, composition of lines, planes, and dots as layers. The attempts however seemed simplistic, too literal, and too scientific of an approach that actually took away from the implicit beauty of the painting. It is in fact this objective impersonal attitude toward painting for which Kandinsky expressed his disapproval, which I was unknowingly implementing.

Wassily Kandinsky believed in the ‘inner necessity’ of the artist contrary to concurrent art movements’ efforts to discipline artists by following universal principles, such as the De Stijl movement in the early 1920s. He opposed the notion of cool objectivity in abstract art, as art should have some dimension of ambiguity that is left open for interpretation by the viewer, a dimension that represents the subjective signature of the artist. Kandinsky elicits this in his statement: ‘There is no ‘must’ in art because art is free’, and it was a later realization for me to try and free myself from those direct literal attempts of analyzing the painting.

The first mode of comprehension that is personally striking for me in Kandinsky’s painting is the immediate one of sensuous cognition. The abstract and the absolute transpire directly to sense perception reaching volatility once the thinking (analyzing) mind attempts to translate the feeling. That is why objectivity as an analytical tool fails due to the inevitable disconnection from sensuous perception. The essential beauty of the painting is that thinking, feeling and perceiving all occur at once in the sensual realm stimulating different imaginative impressions with different contemplators.



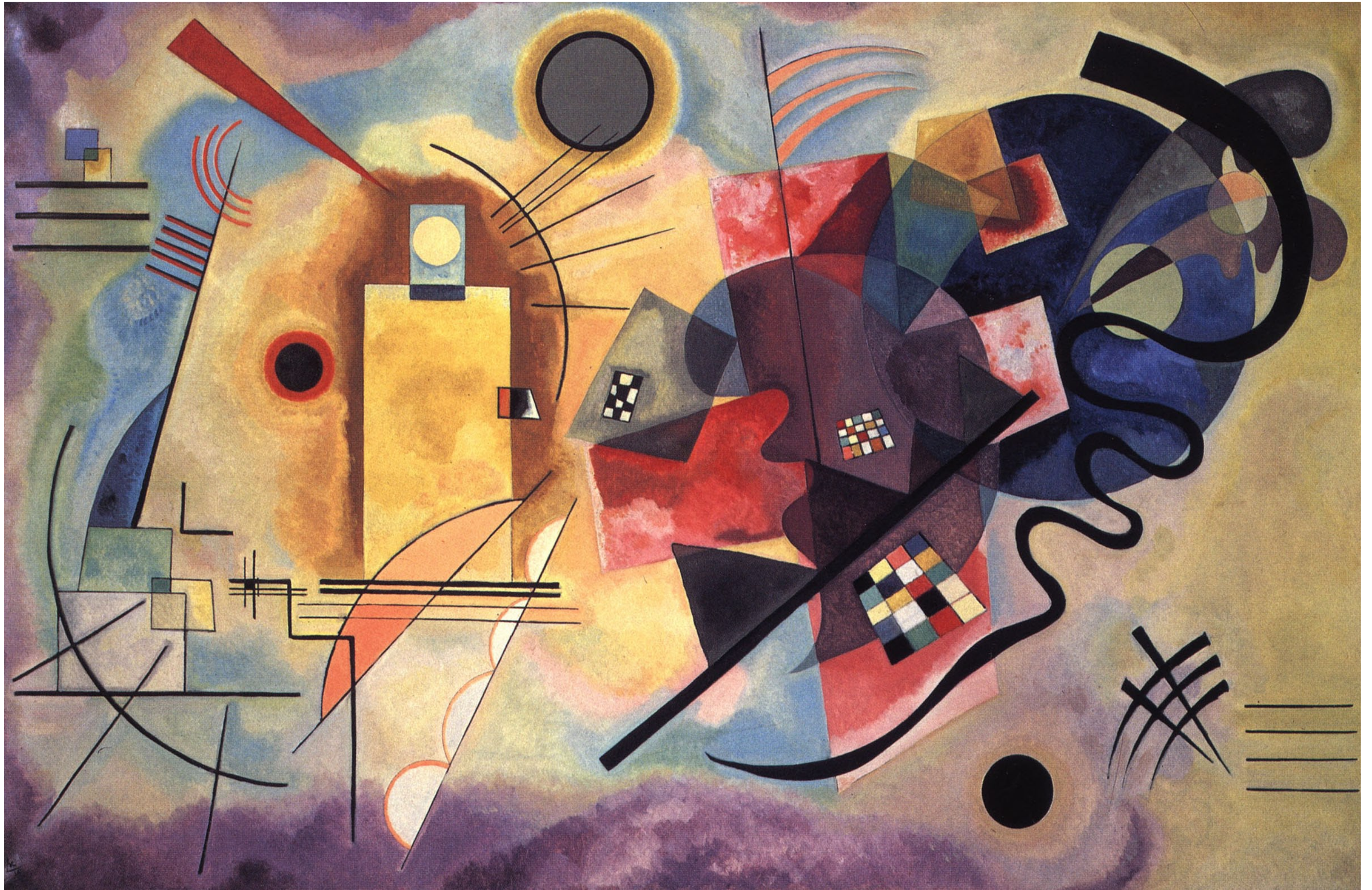



## FORMAL EXPLORATION

The question 'what' disappears, and the question 'how' becomes more important. I decided to make a model of the painting as a tool for exploring 'how' the painting elements interact with each other.

Making a model of the painting gave me an insight into the formal composition of the interactive shapes. The model was an attempt at formal exploration and thus colors were excluded from the study. Color, however, guided me to a three dimensional interpretation, so that the darker shapes were subtractive and repressed in nature, while the lighter in tone became additive and elevated.

In 'Yellow, Red, Blue', the elementary means of art -- line, form, and color -- are not used for any other purpose than to reveal harmony and balance. It is the art of relationships between such elements that insightfully reveals the balance of the collective when reading the painting holistically. Through such interactive engagement with each other, the forms overlap, touch, intersect and subtract from each other, subsequently adding a suggestive dimension in addition to their original genetic purity.

The interaction itself is the datum that allows for the transformational effects on the elements. However, forms bear different qualities according to the nature of the different types of forces inferred, so the more pure the form the more static and gravitational, and the more suggestive (transformed) the form the more dynamic and sublime. The order of the painting draws from the relationships between the seemingly irrelevant shapes forming a cohesive collective amalgamation.

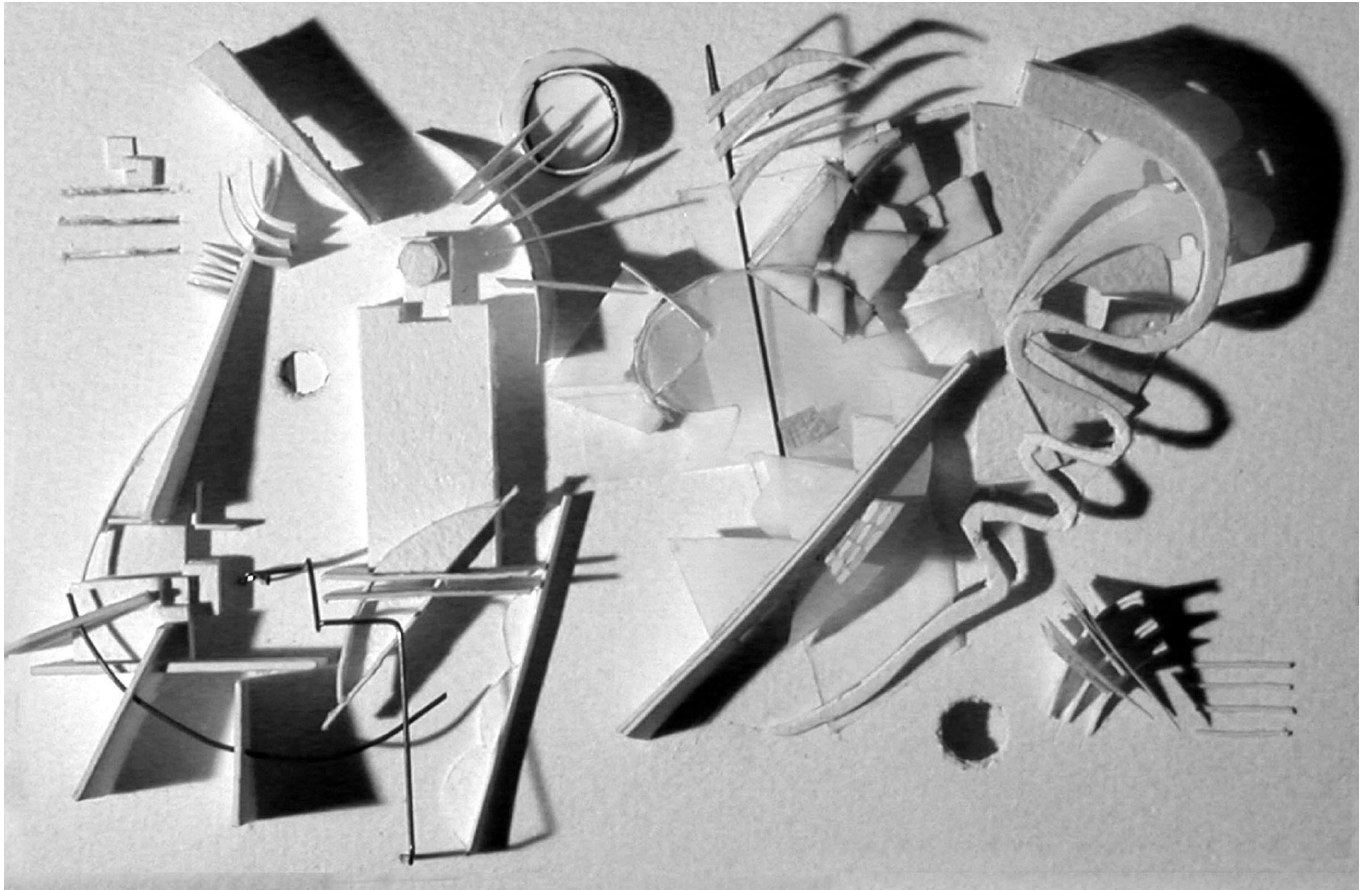



The subtractive and intersecting relationships between the forms become elemental in producing a set of forms that start to transform, some maintaining a rectilinear identity but losing their rectangular purity through tapering; some become biomorphic through pinching, while some simply maintain their original shape character and only become affected by subtraction and addition. Such acts of transformation on the canvas led me to speculate on their three dimensional representation.

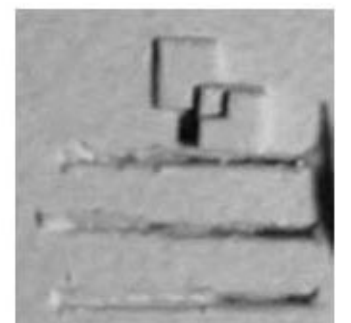
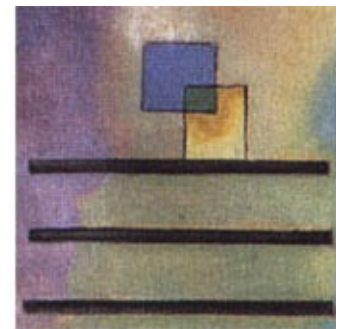
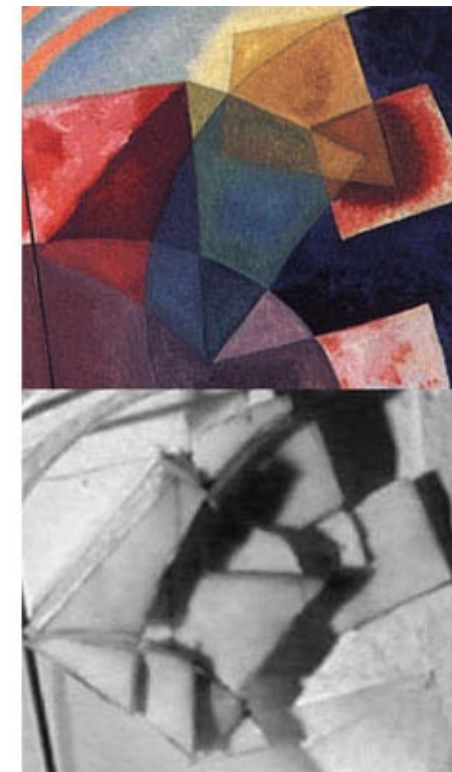
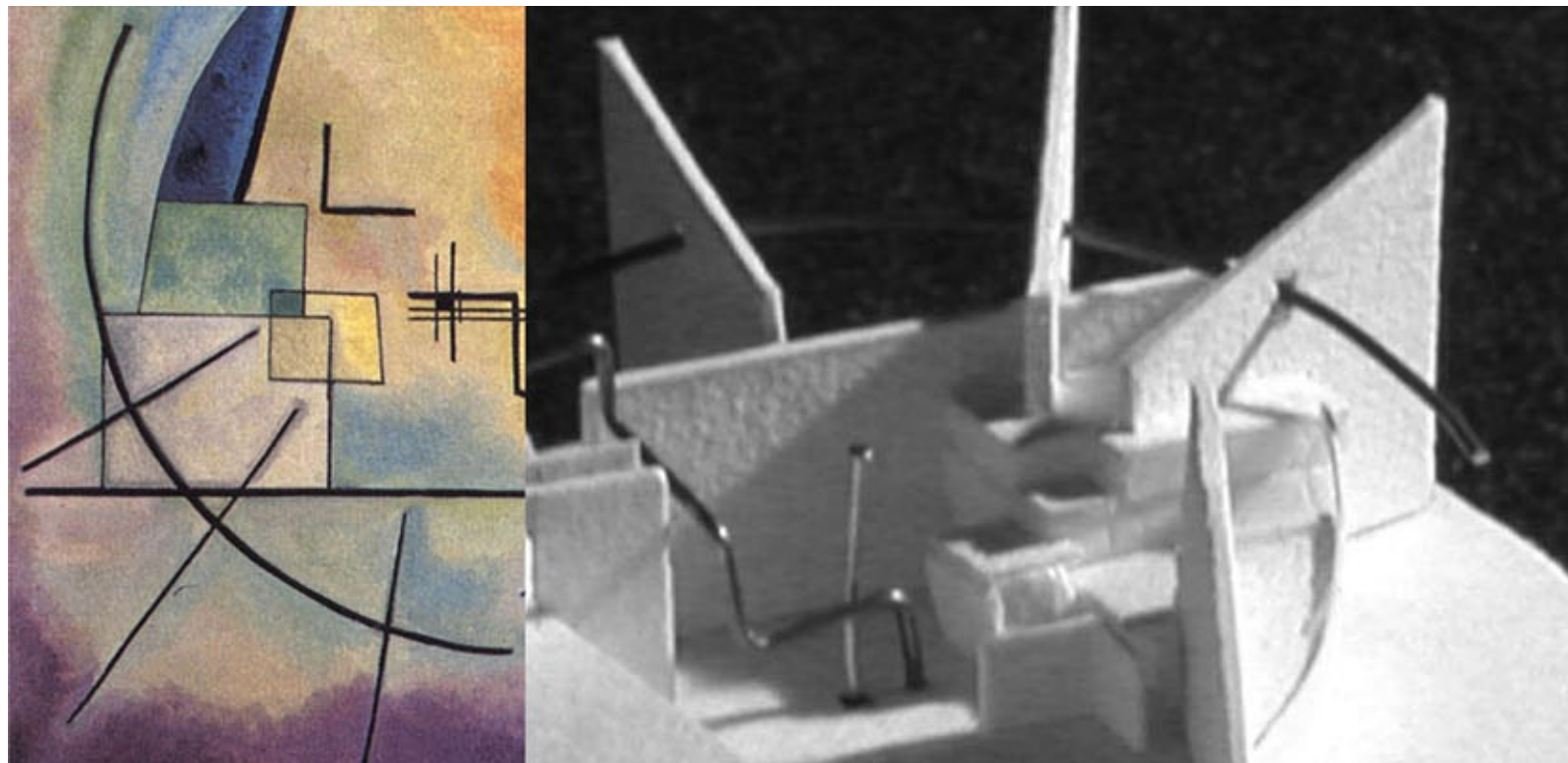

What I found intriguing about the painting is the relations between the diagonal/oblique and the horizontal and vertical as both seem to stabilize and mobilize each other visually. But I also observed that as the diagonal lines gain thickness they tend to narrow as they transcend in length to their end melding with the surroundings. While constructing the model, the observation of this inclination in plan hinted at similar behavior in elevation, where the lines become shorter in height at the narrower end, some touching the ground and fusing with the background.

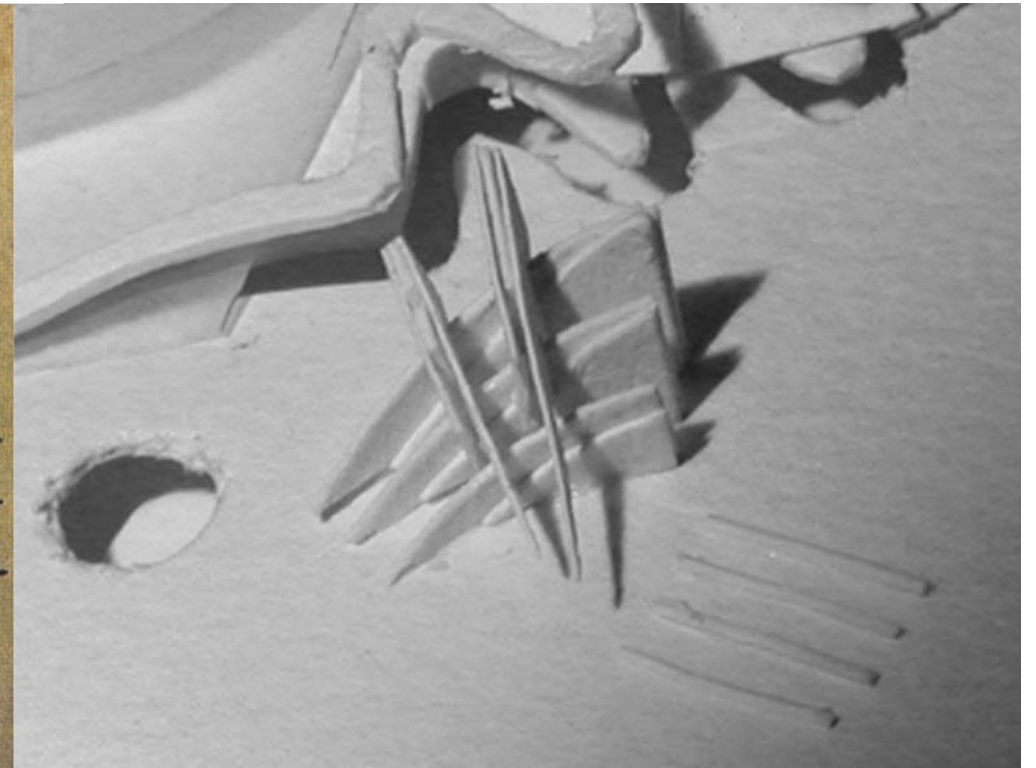
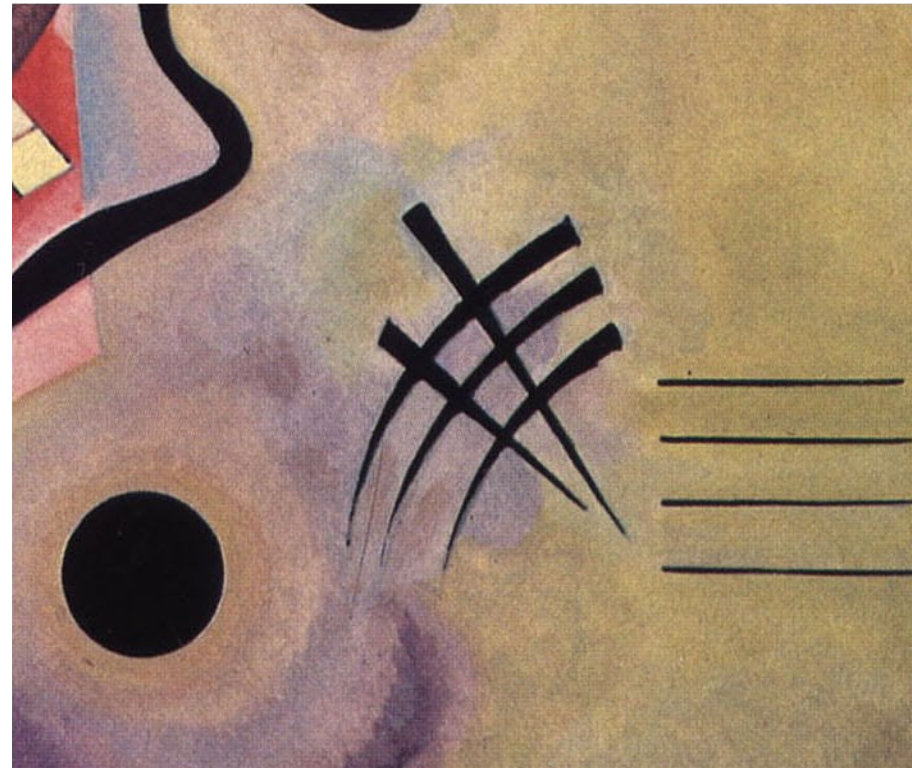
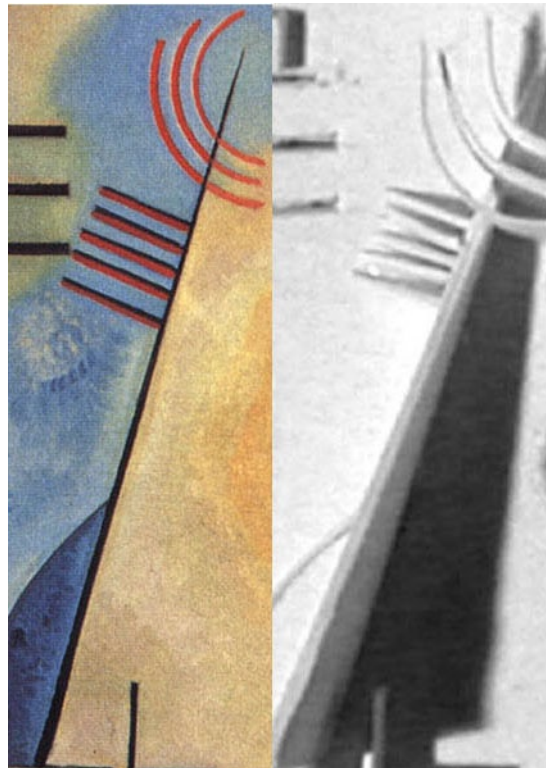

## REFLECTIONS

After this three dimensional attempt at analysis, I started sketching and drawing diagrams of what I learned and captured from the painting.

The sketch shows different impressions from the painting resulting from acts of intersection: from right to left, biomorphic curvy intersections to rotated intersecting rectangles to chamfered remnants. All throughout, the idea of balance and equilibrium works to arrive at a final visual stability. The latent energy of such formal resolution exhibits harmony in tension.

After introspective delving into the painting and ways of capturing 'the perceived' comes the realization of the need to deal with the other design inputs of my project. From the painting, the idea of intersecting lines and planes will be further explored to an architectural realization of intersecting volumes and spaces. Based on that, comes the need for studying and analyzing the site along with the programmatic nature of the building.



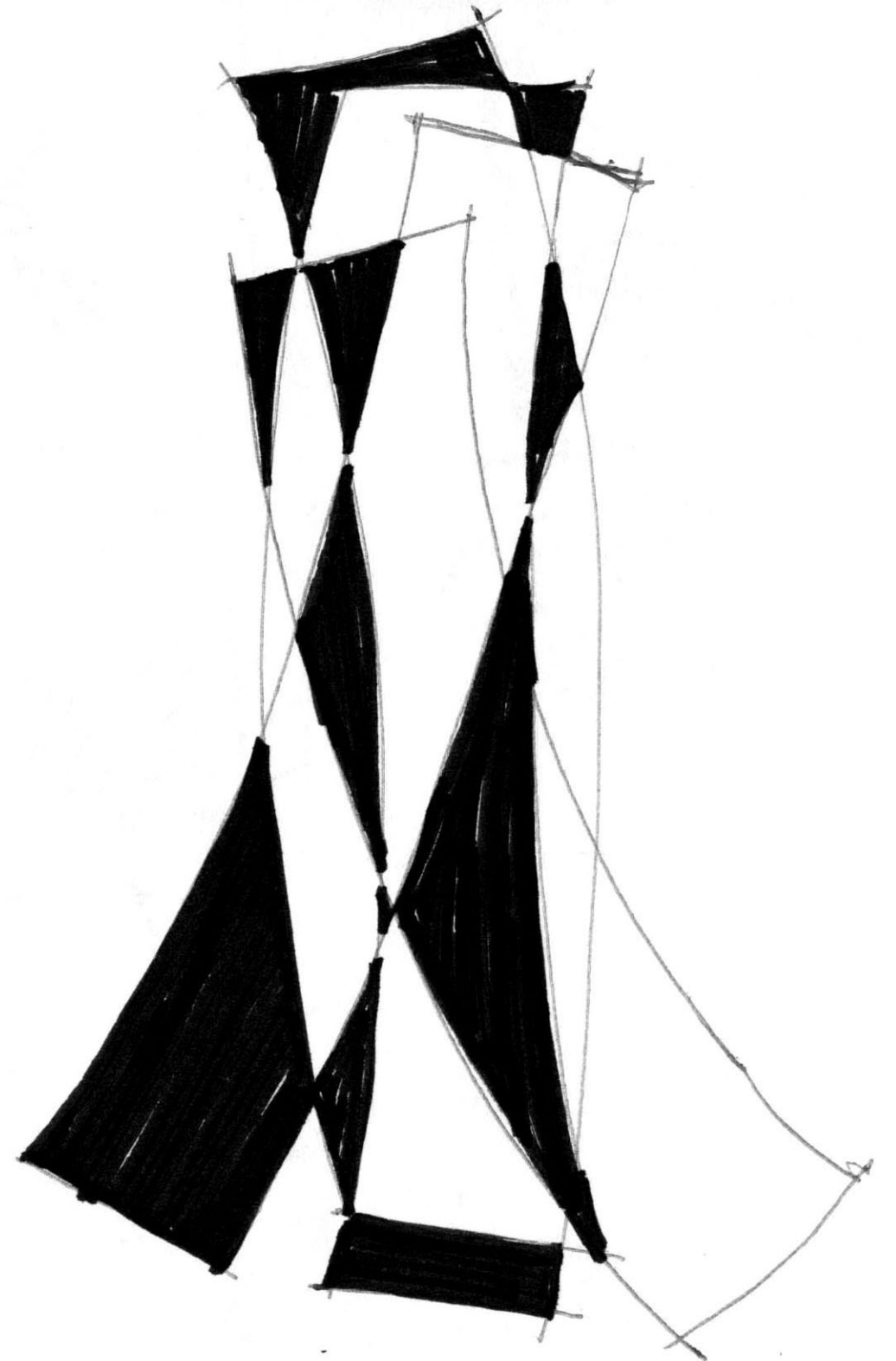
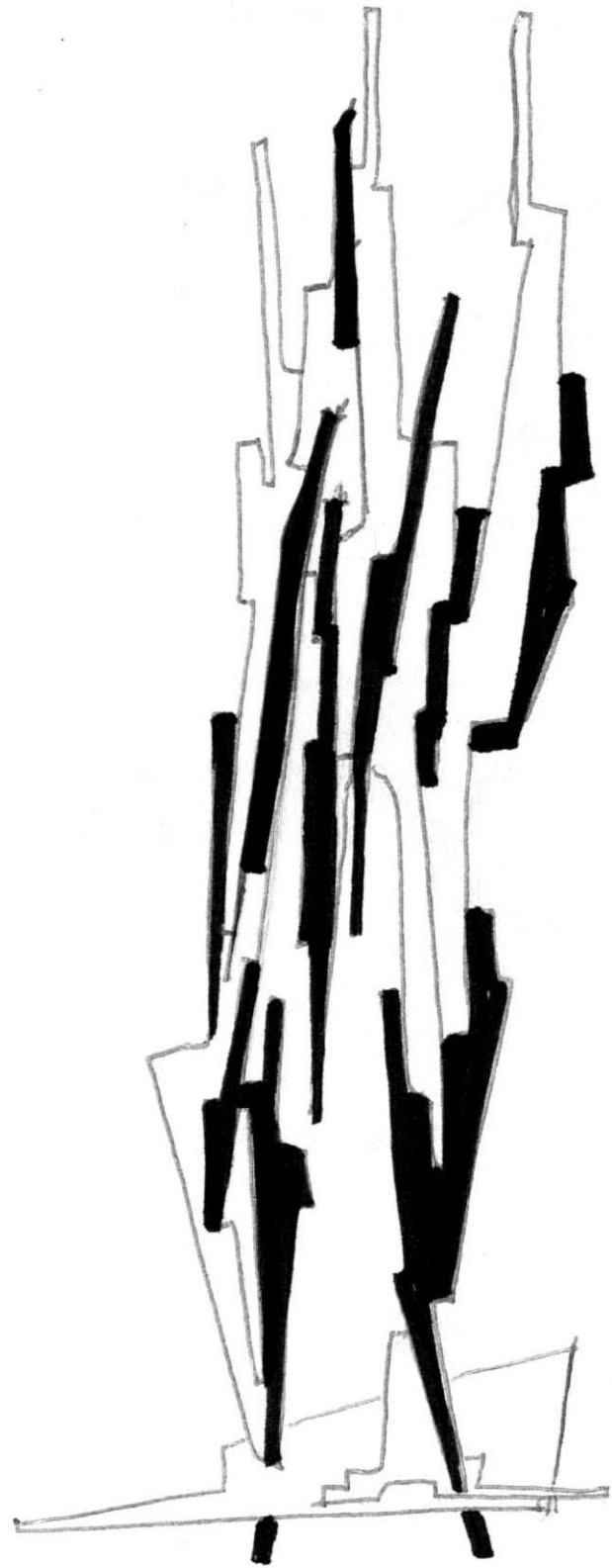

## THE SITE

The site is located on the edge of the Virginia Tech campus close to downtown Blacksburg, Virginia. The north-west view shows Squires Student Center; the north-east view shows the commercial strip of downtown Blacksburg; the south-east view shows the Virginia Tech Architecture Annex building; and the south-west view shows Donaldson Brown Hotel and Conference Center.

The location of the site is particularly important in its proximity to the people of Blacksburg and the students and staff of Virginia Tech University, thus attracting the public to the art center, and enriching the cultural scene of Blacksburg. The art center would provide spaces for hosting cultural and artistic events that engage both communities and would create an outdoor interactive environment with the surroundings.

The impressions taken from the painting stimulated the analytical approach to the context. I started out by extending lines of the surrounding buildings to form a rich matrix of parallel and intersecting lines in different directions. The lines presented a constructive layer for the consequent design iterations of the building, conceptually following the main theme of intersecting spaces.



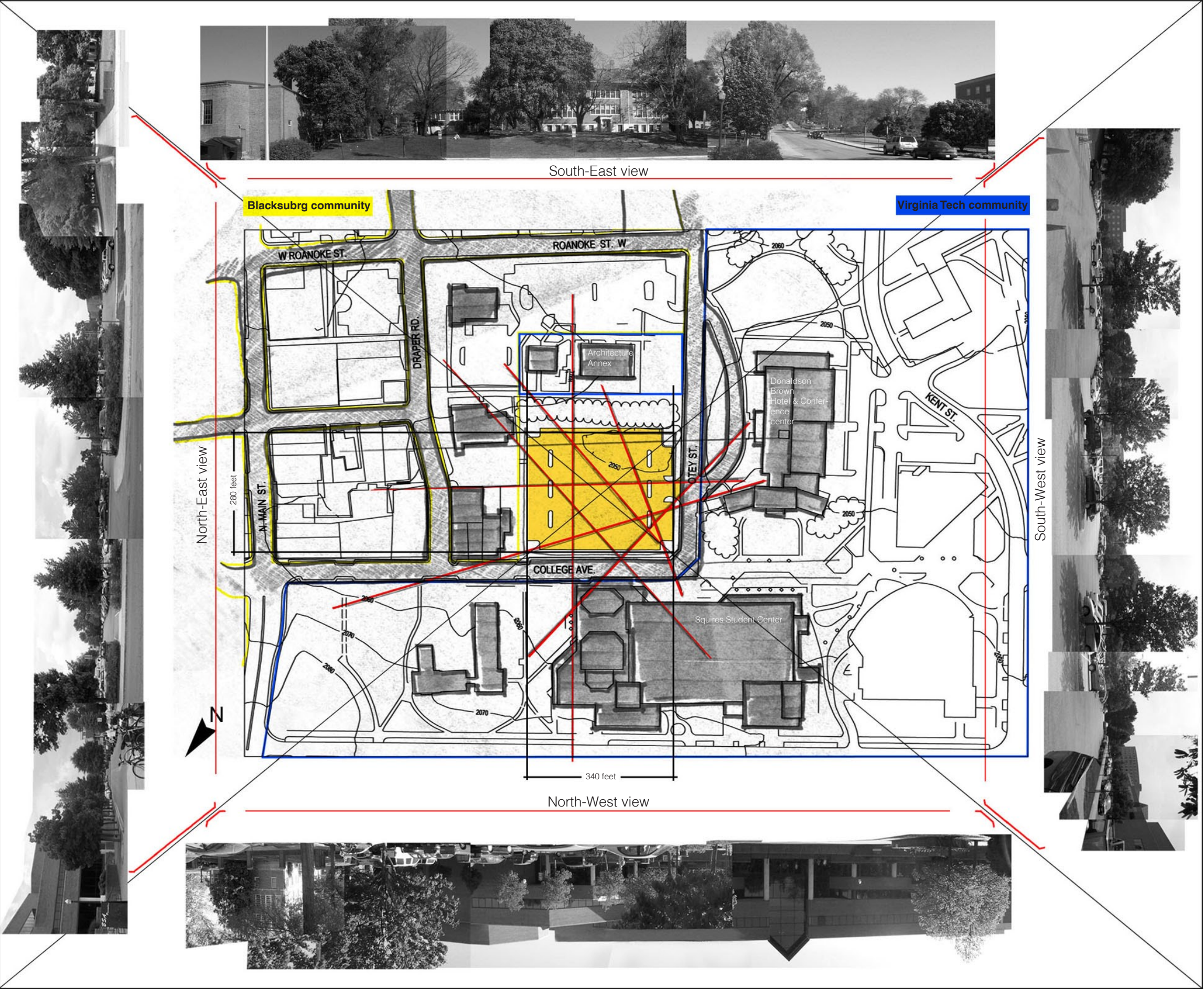



## EARLY ITERATIONS

From: ABSTRACT CONCEPTION

The spaces of the building tend to follow the line matrix of the site where accessibility to the art center is to be facilitated from three sides, allowing access from downtown Blacksburg, and forming an extension of urban space for the Virginia Tech campus.

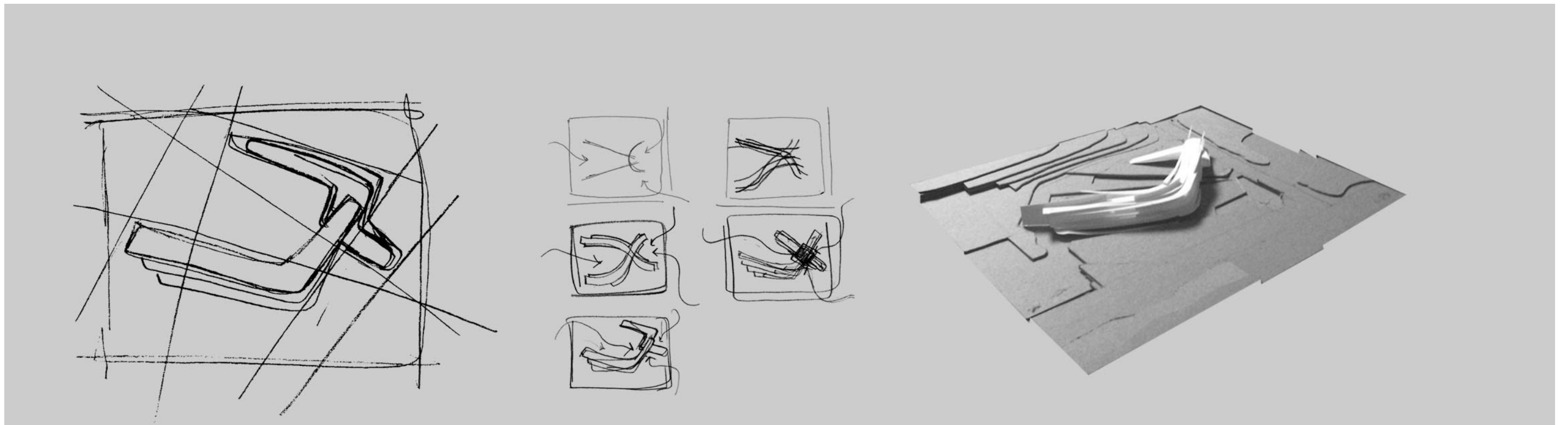

## To: RESOLVING FORM

The spaces start to arise from the idea of intersecting spaces, where lines from the previous stage form a transparent network that is guided by the forces of how to approach the site. The main gallery spaces are elevated to create visual continuity with the surroundings.

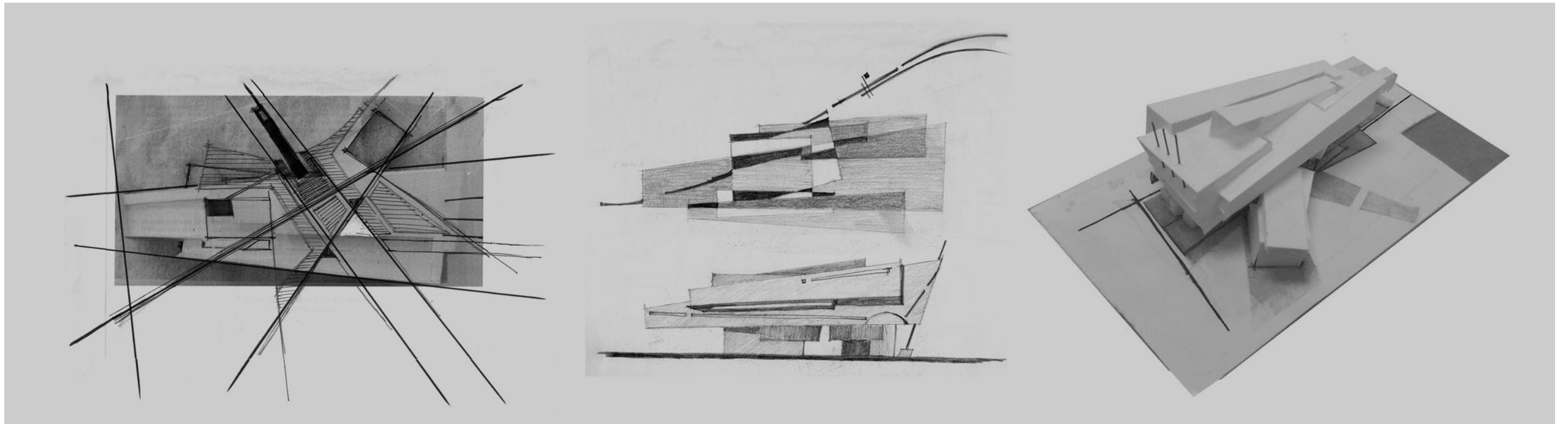

To: EXPRESSIVE STATEMENT

Spaces become more pronounced in their volumetric interplay to the extent of disconnection with the site. The question of urban integration becomes more pressing to reach equilibrium where the initial idea of intersecting spaces does not cause urban seclusion.

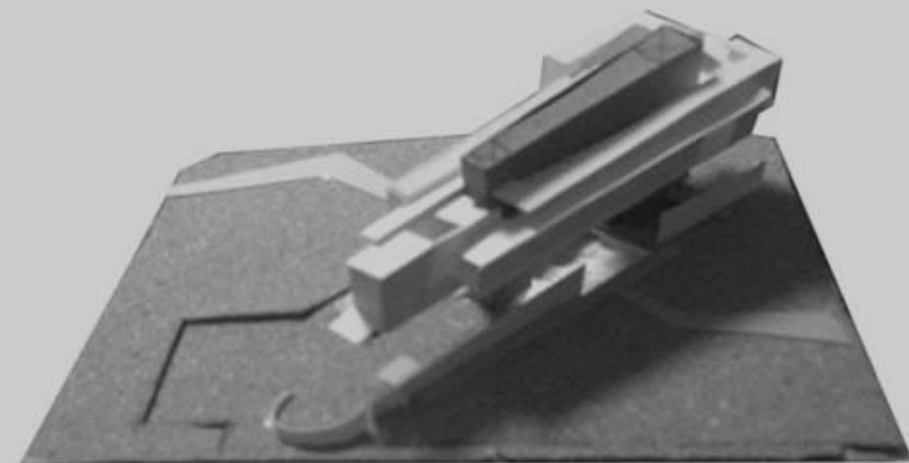
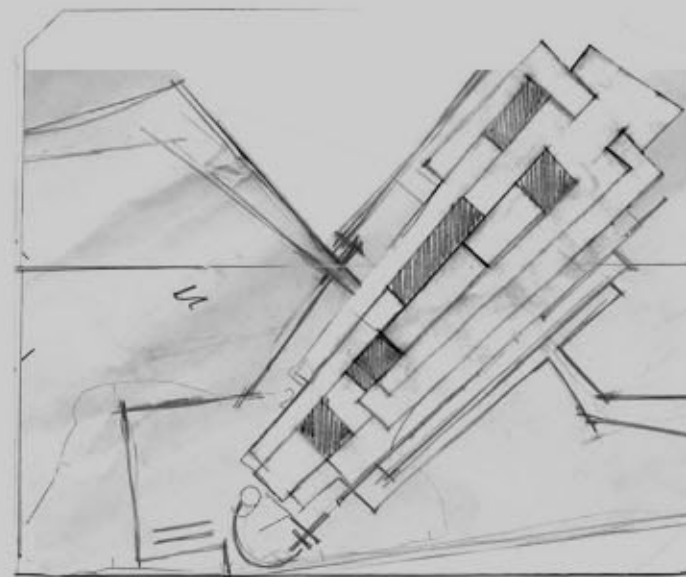



To: URBAN INTEGRATION

The final resolution of the configuration takes the 'L' shape. The ground mass of administration spaces intersects the elevated mass of gallery spaces creating axes of visual continuity on the ground level. A question arises here regarding the building's load-carrying structure, and the design later changes from the idea of the structural core bearing the spaces cantilevering in and out, to the idea of two main structural shear walls to support the cantilevering volumes. The latter solution came about due to the consequent disadvantage of limiting the openness of the interior space once a structural core existed.

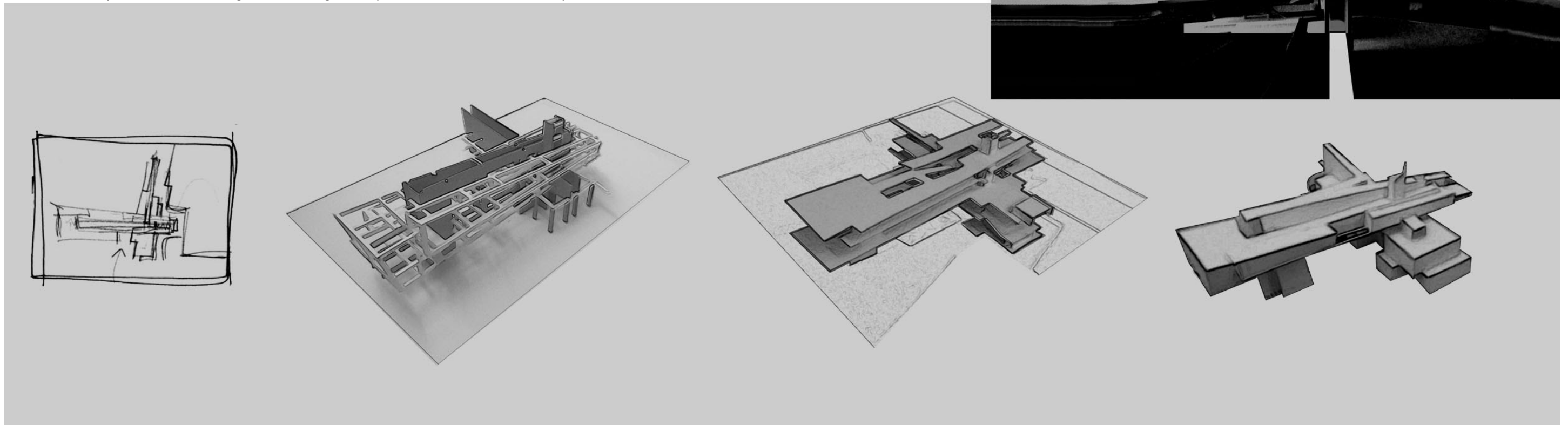
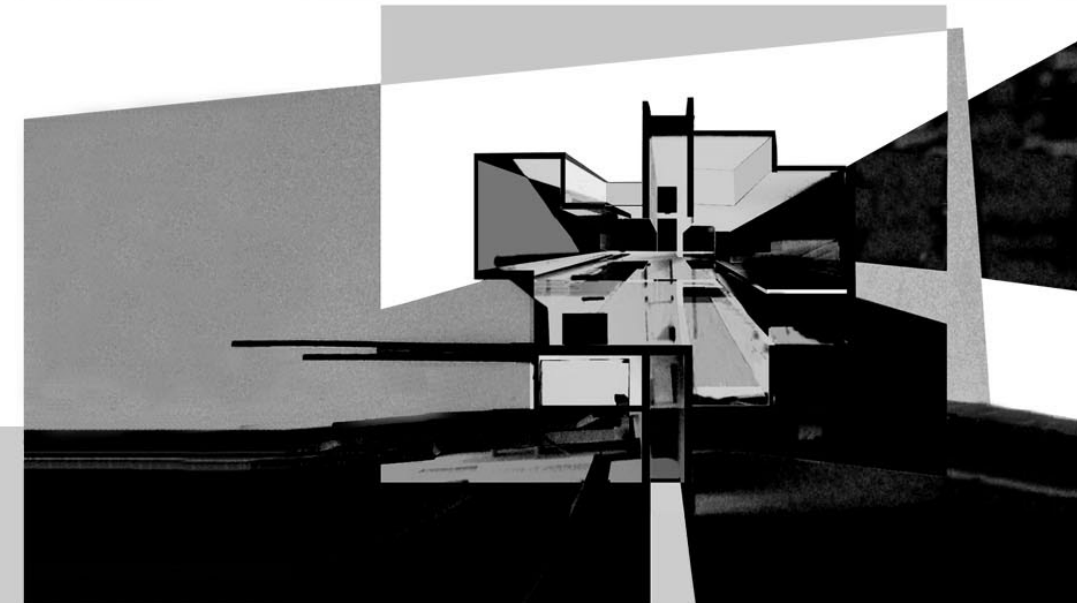



## INTERSECTING VOLUMES

Additive cantilevering volumes intersect the structurally supporting parent volume, while the subtracted volume in the center pours in light to the building's interior. Following my prior painterly impressions of obliqueness in plan and elevation, the volumes slope downward from the wider end to the narrower one.

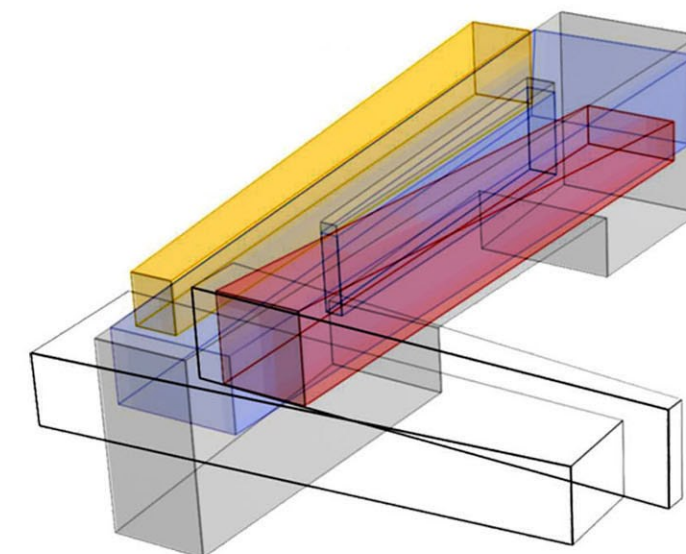
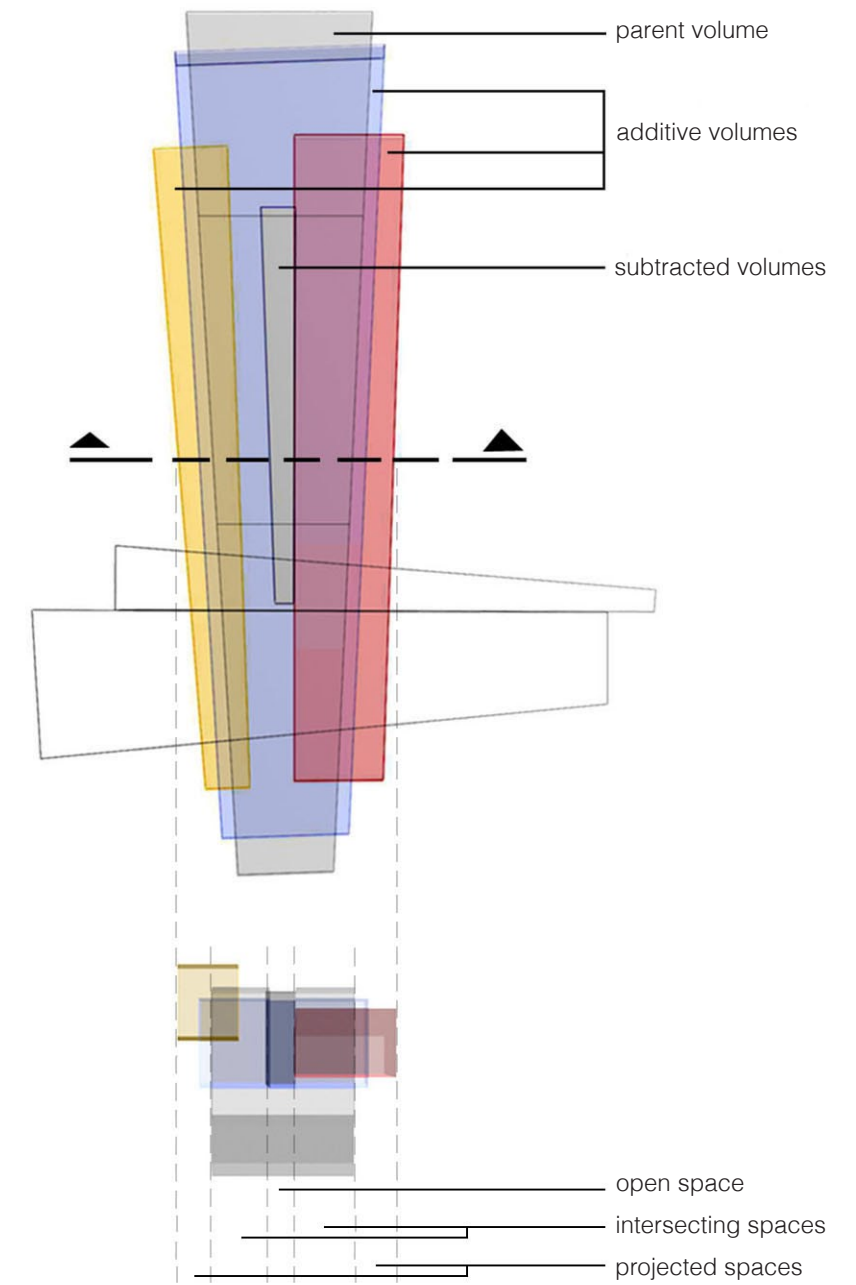

## STRUCTURAL ASSEMBLY

The administration building on the ground level follows the post and beam structural system intercepted by the two main structural walls supporting the elevated cantilevering galleries. The walls transform vertically into transfer beams to support the cantilevering plates made of cast-in-place concrete. Circulation spaces of elevators and stairs act as structural anchor points.

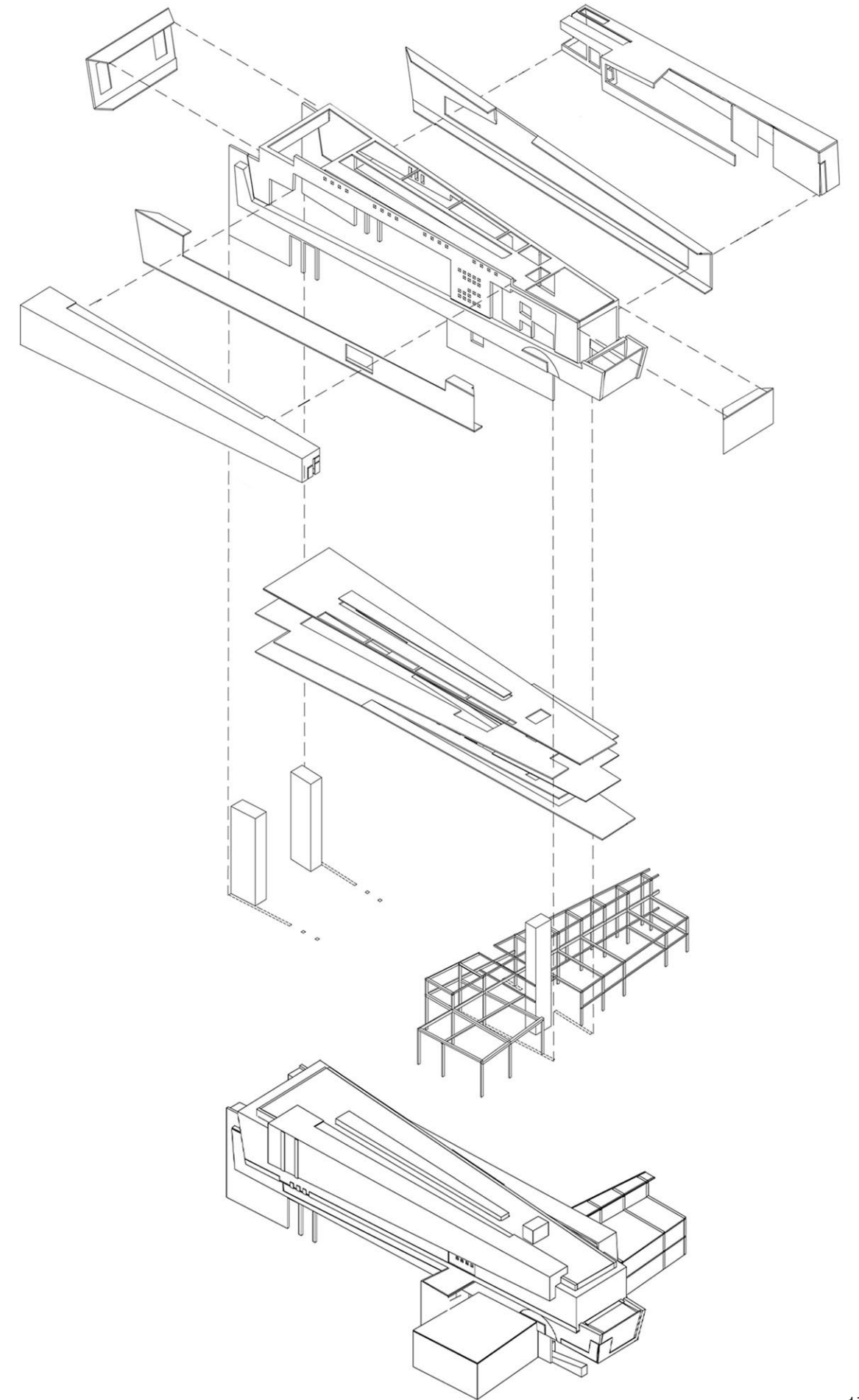

## CIRCULATION

Movement through the linear exhibition spaces allows a lateral experience of contemplation of art exhibits, interacting visually with other people on the other side of the gallery. Sloping floors and split levels add the perception of motion to the overall sensory reading of the architectural composition.

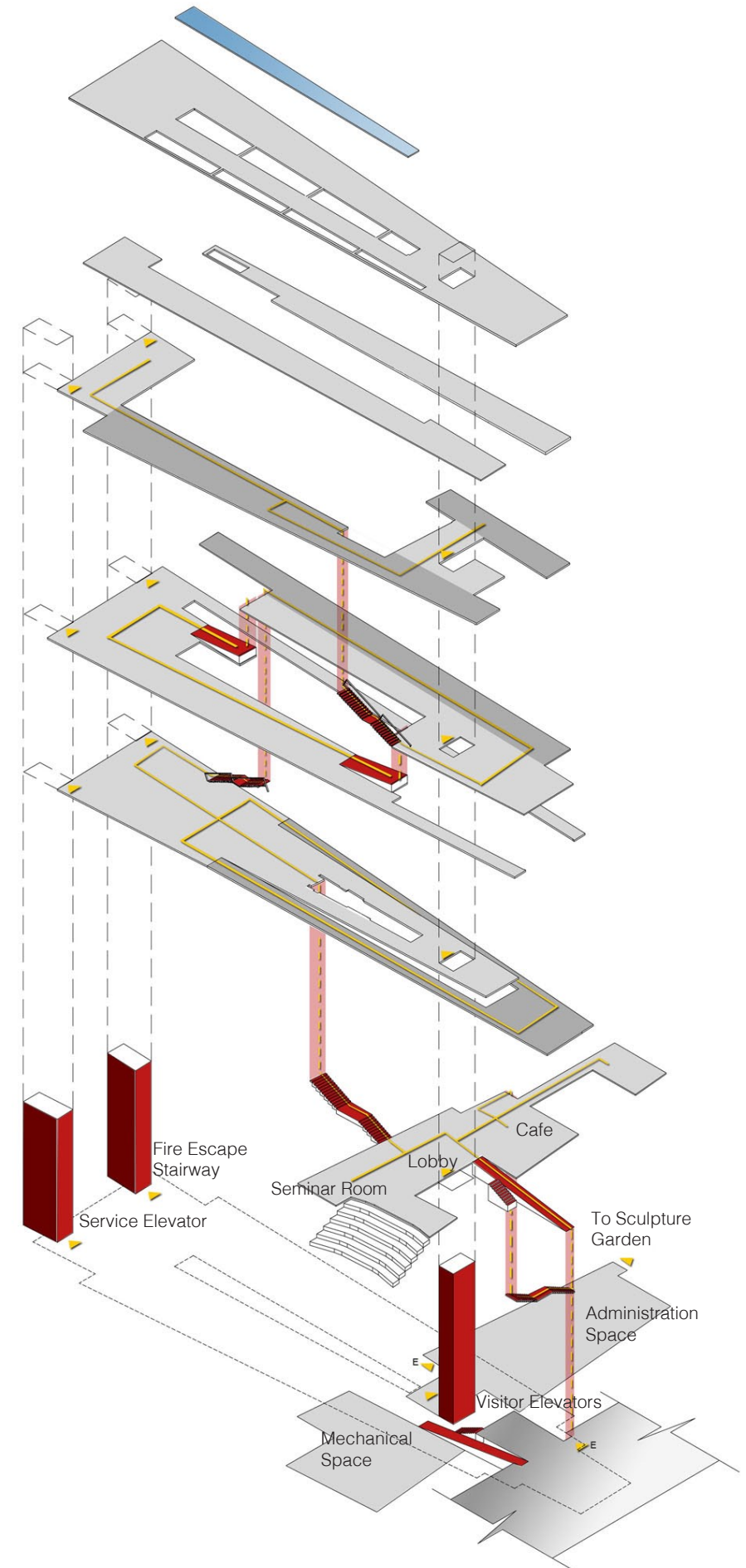



## COLOR

An early decision was made to leave a neutral white wall for the paintings, while inserting some colors, limited in proportion, to highlight some architectural elements. Color insertion follows the awareness that paintings should be focused upon, and therefore avoiding unnecessary visual conflict. The color red distinguishes stairways as the most striking and pulling to the eye, with yellow accentuating some structural elements. Motion through the space becomes contemplative along the walls of paintings, while it becomes more dynamic and visually interactive as the volumes open up.

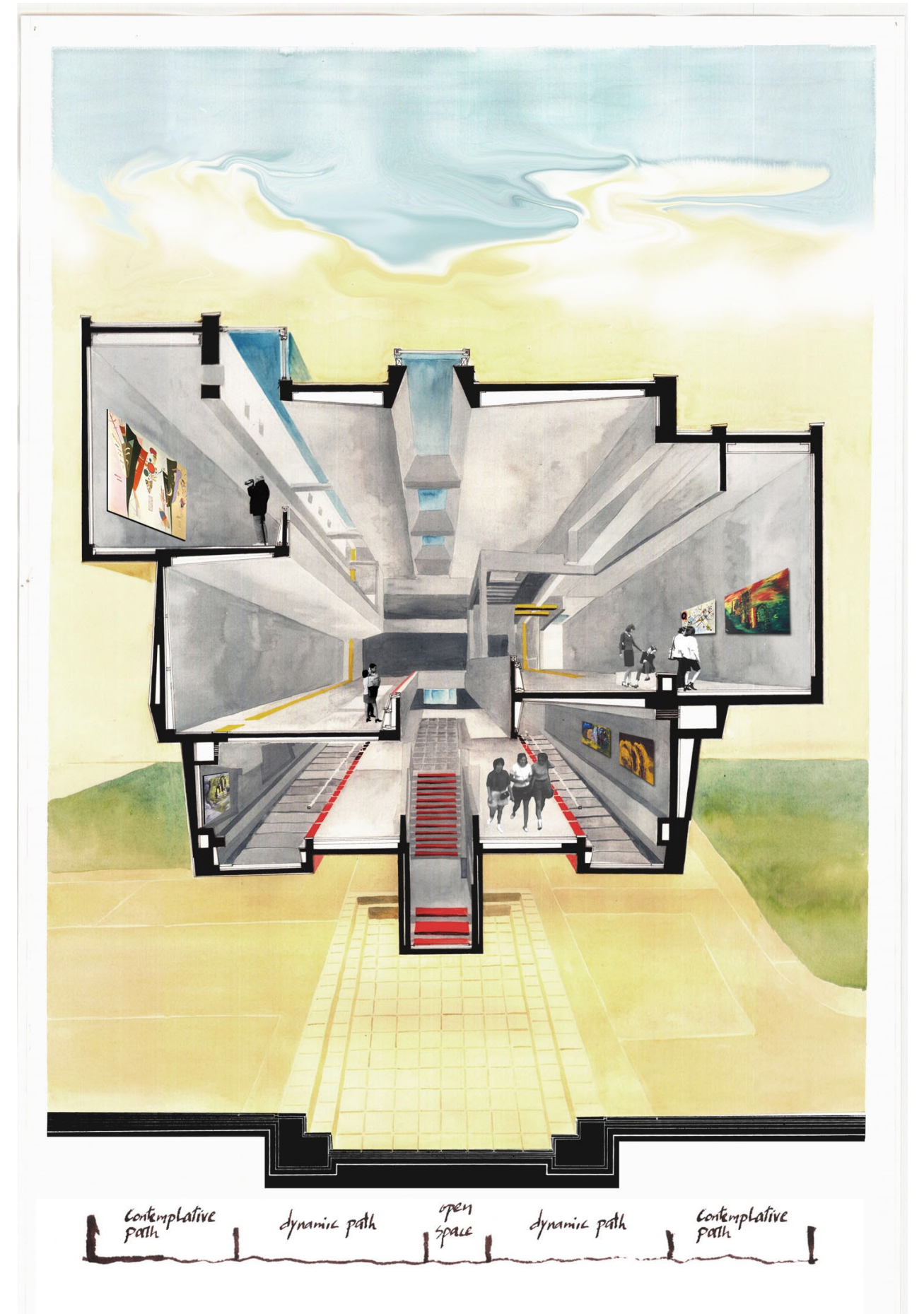

## BACKGROUND TO FOREGROUND RELATIONS

“Color is the key. The eye is the hammer. The soul is the piano with its many chords. The artist is the hand that, by touching this or that key, sets the soul vibrating automatically.” (1) Wassily Kandinsky.

Music is usually associated with Kandinsky's paintings, with their rhythmic shape/color sensitivity. Studying 'Yellow, Red, Blue' reveals clear color attribution for the elements on a background of color fusion. The outlining of colorful forms versus the hazy fluid background moves the elements forward to the eye. The curious polarity of the shape of objects and the qualities of paint and color are implicit in the painting. The name of the painting suggests a reading from the left to the right, characterizing the color yellow for a defined set of elements like rectangles, a warm color moving outwardly, while the color red occurs as the transition when meeting the dark blue circle on the right, a cold color for a stable inward shape.

Analogous to background and foreground relations in the painting, the typology of the art center stands out expressing its difference from the squarish buildings around it; the building is to its site as a canvas to a wall. The site provides a rich background of earthy colors and woven textures of the surroundings from brick to wood to trees. Such rich homogenous patterns of the context instill an immaterial attribution to the art center stating its contrast as a visual presence among the surroundings, achieved by applying white plaster on the surfaces along with playful coloring as part of the holistic formal reading of the building.

(1)Wassily Kandinsky, 'Kandinsky, complete writings on art / edited by Kenneth C. Lindsay and Peter Vergo.', Boston, Mass. : G.K. Hall, c1982. Page (160)













Northern Elevation الواجهة من الشمال



Southern Elevation الواجهة من الجنوب



## DRAMA OF LIGHT

Willem Maris : 'I do not paint a cow, I paint the light' (2).

Perception of color through light on a painting allows for analogous impressions in an architectural space. When light strikes a surface it imprints and substantiates a different texture and hue of the color from the same color in shade. Where spaces intersect, light plays a dramatic role in the unraveling of the architecture, so when it strikes a surface it stirs our imaginative perception, becoming more pronounced when this phenomenon differs from one level to another. Direct light seeps in from the south through openings and roof skylights adding a rhythmic dimension to motion through the space, creating architectural moments through the shadows created.

Indirect light floods the space through the main roof skylight that is a continuation of the central subtracted volume. Main considerations in carving out a dramatic striking of light were the positioning of openings, their height and shape, so that when light filters through, it does not strike exhibit walls, but instead highlights the dynamic path and the interactive visual environment of the architecture.

(2) Allan Doig, 'Theo Van Doesburg: Painting into architecture, theory into practice', Cambridge [Cambridgeshire] ; New York : Cambridge University Press, 1986. Page (15)



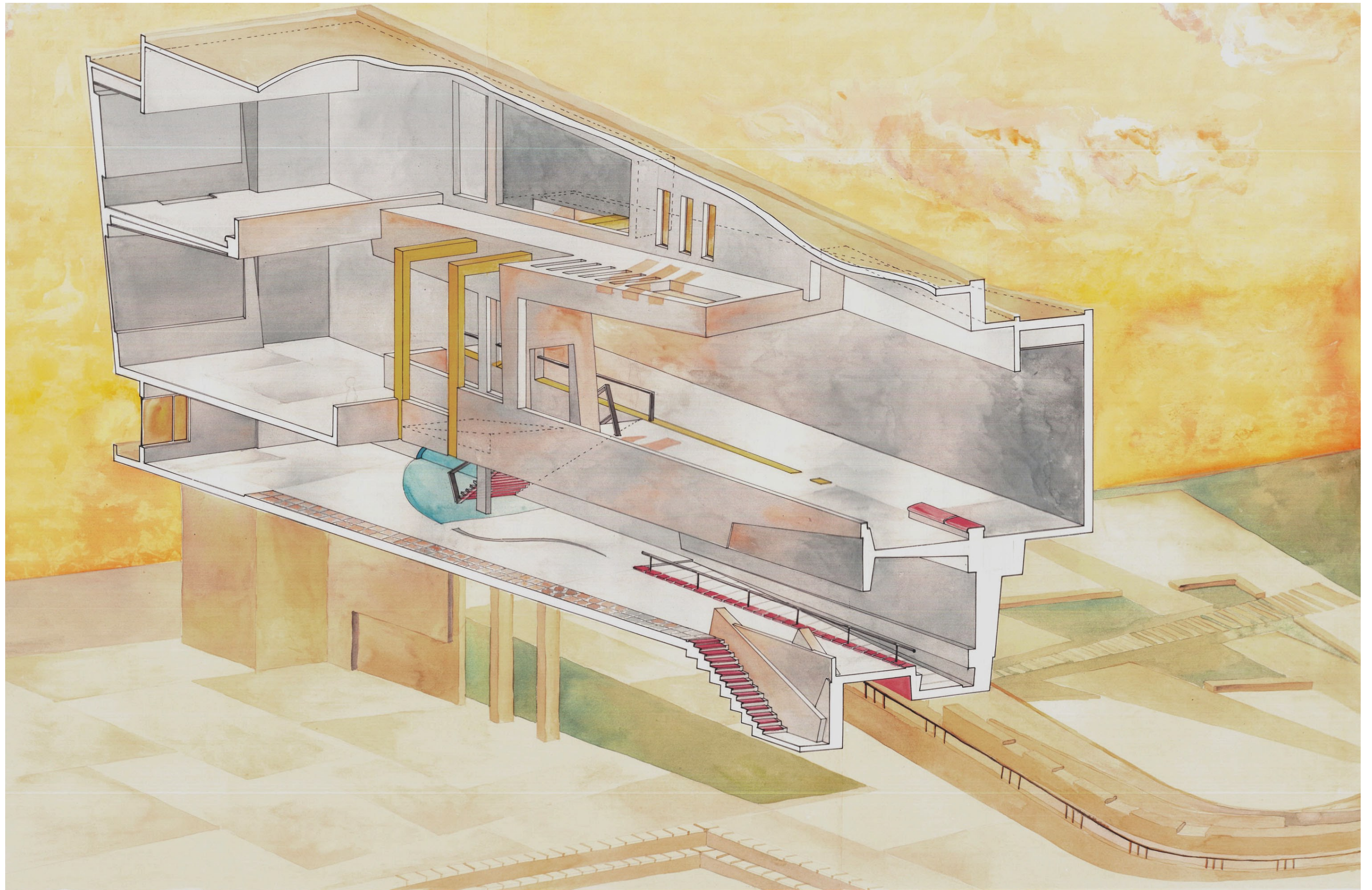



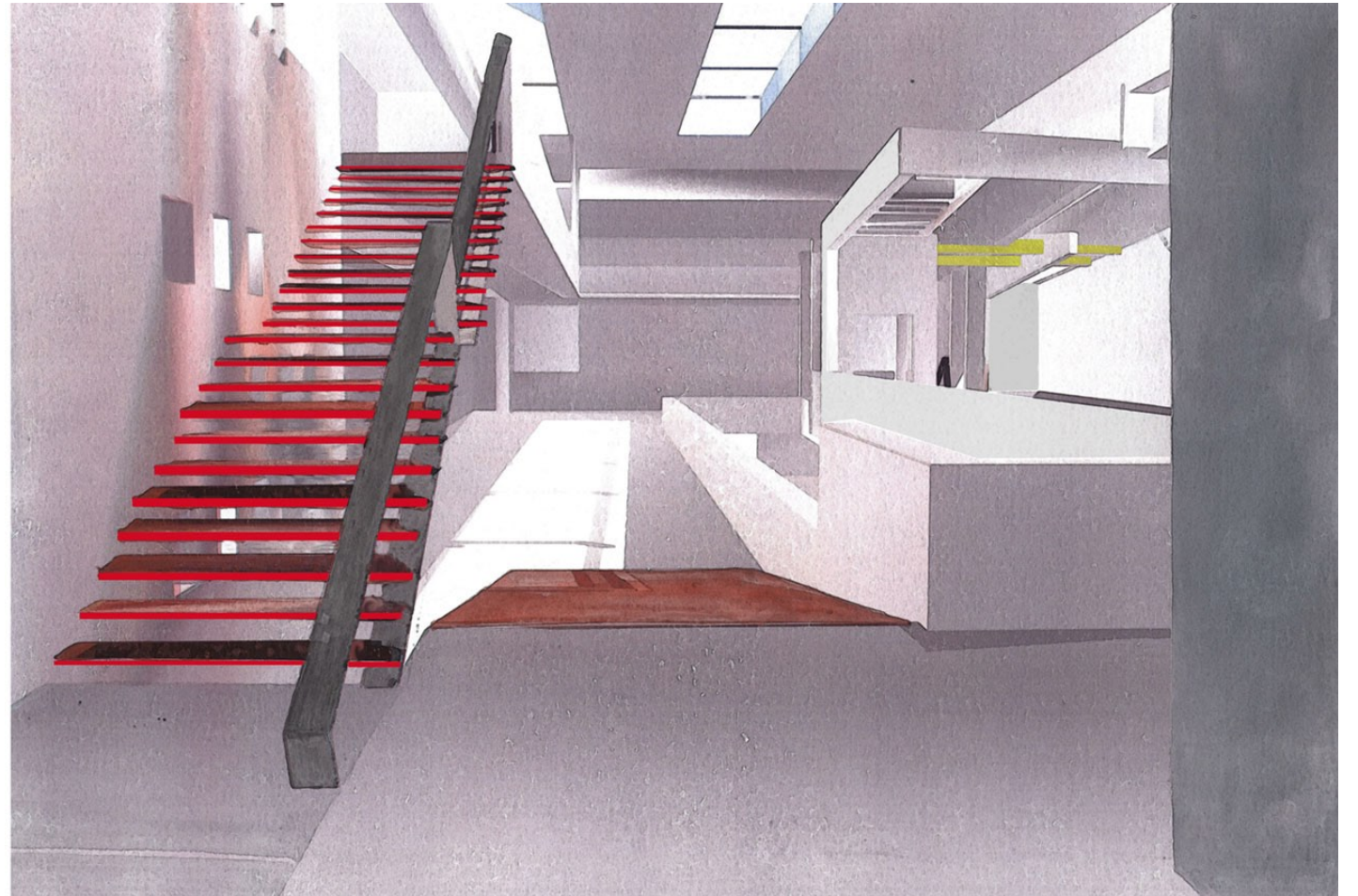



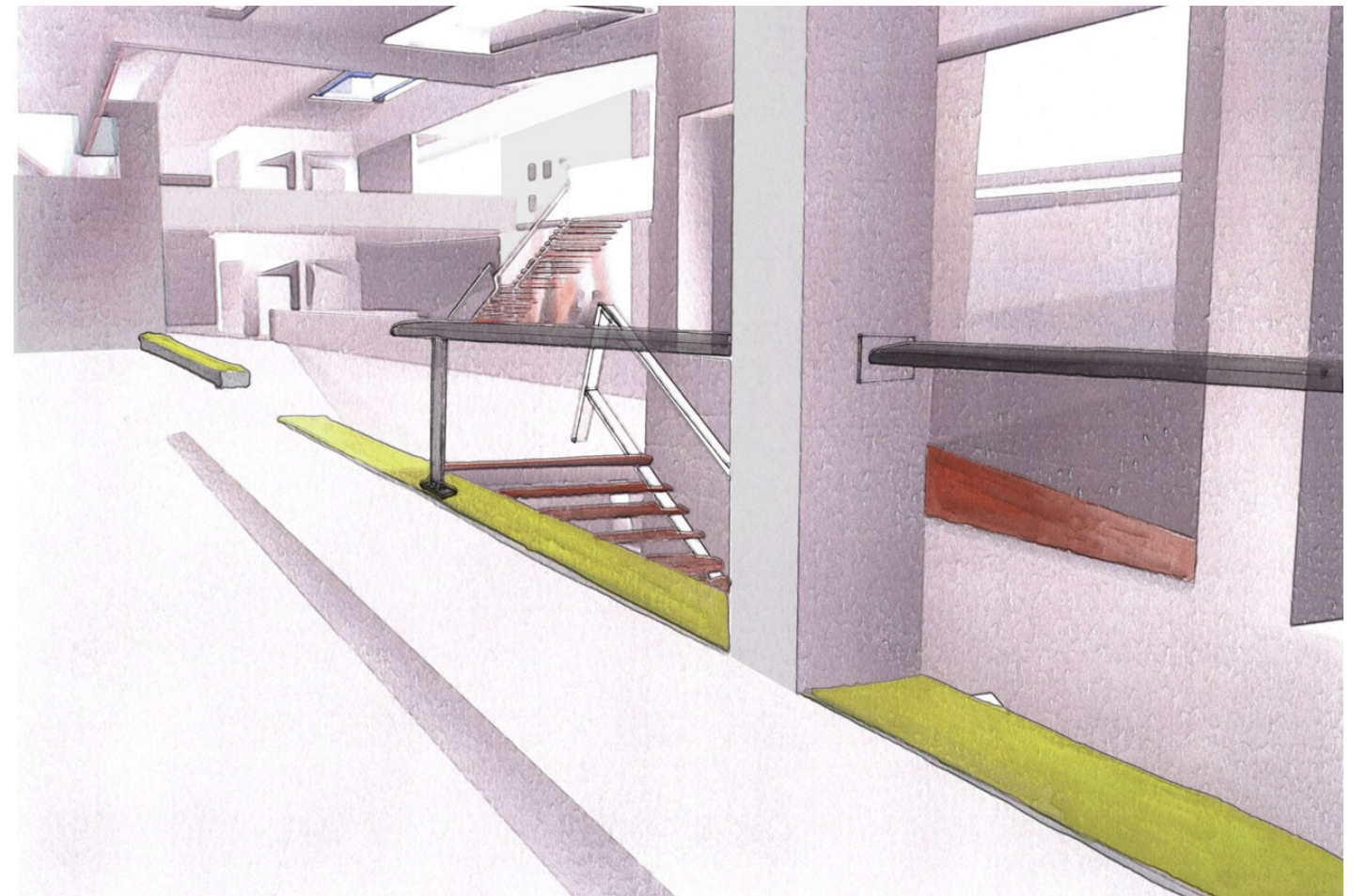





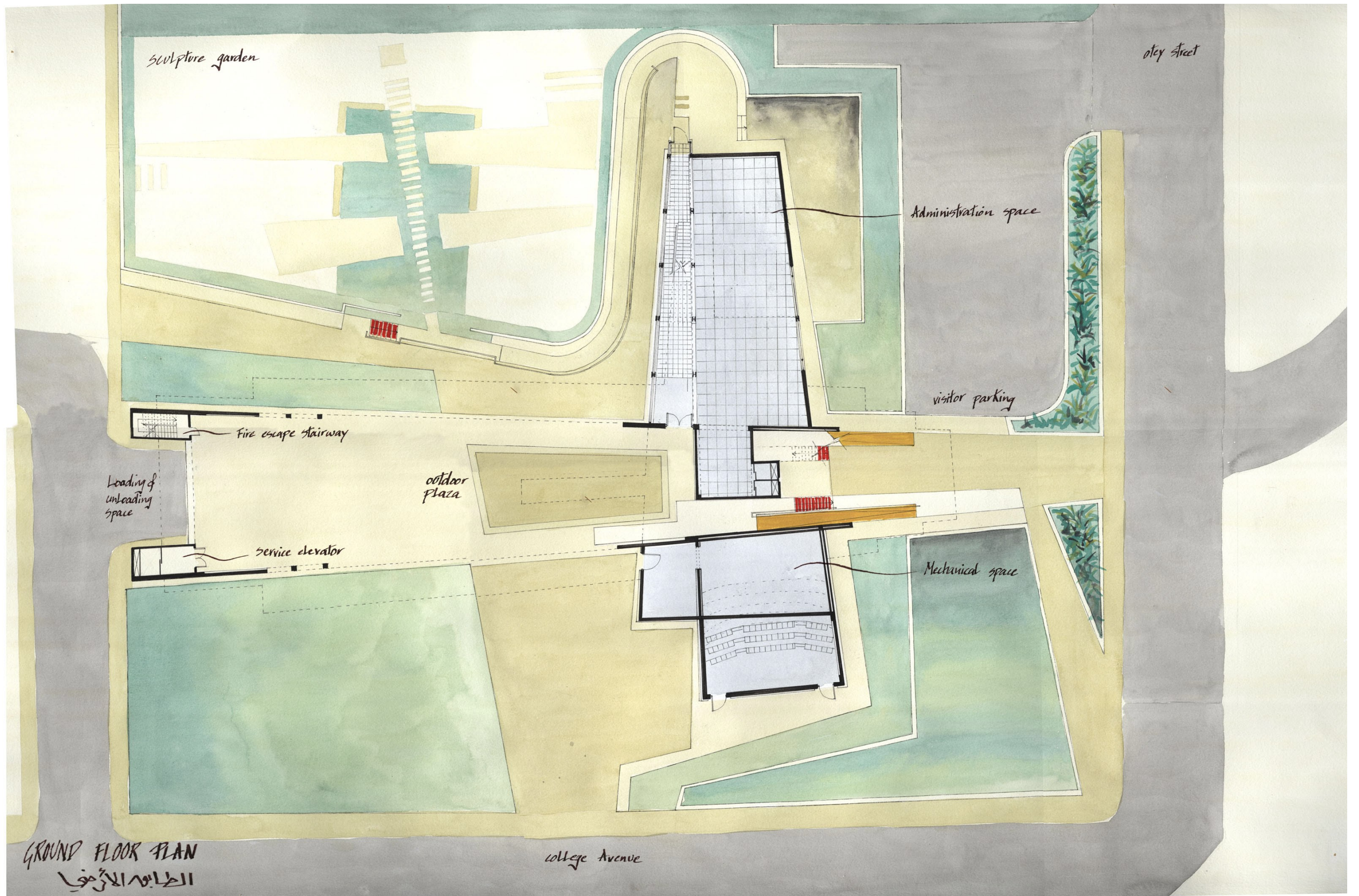

sculpture garden

Oley Street

Administration space

visitor parking

Fire escape stairway

Loading & unloading space

outdoor plaza

service elevator

Mechanical space

GROUND FLOOR PLAN  
الطابق الأرضي

College Avenue



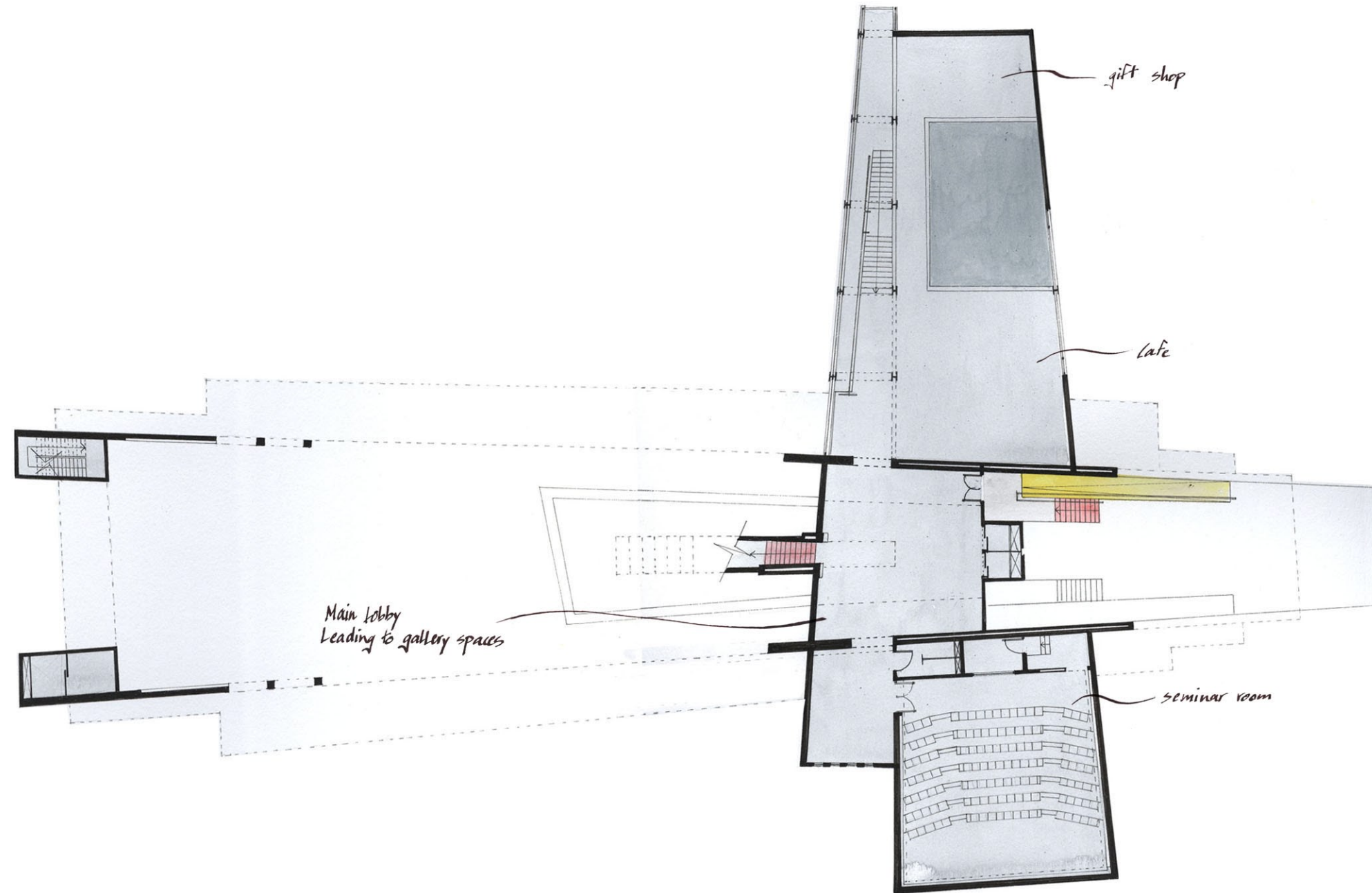

FIRST FLOOR PLAN  
الطابق الأول

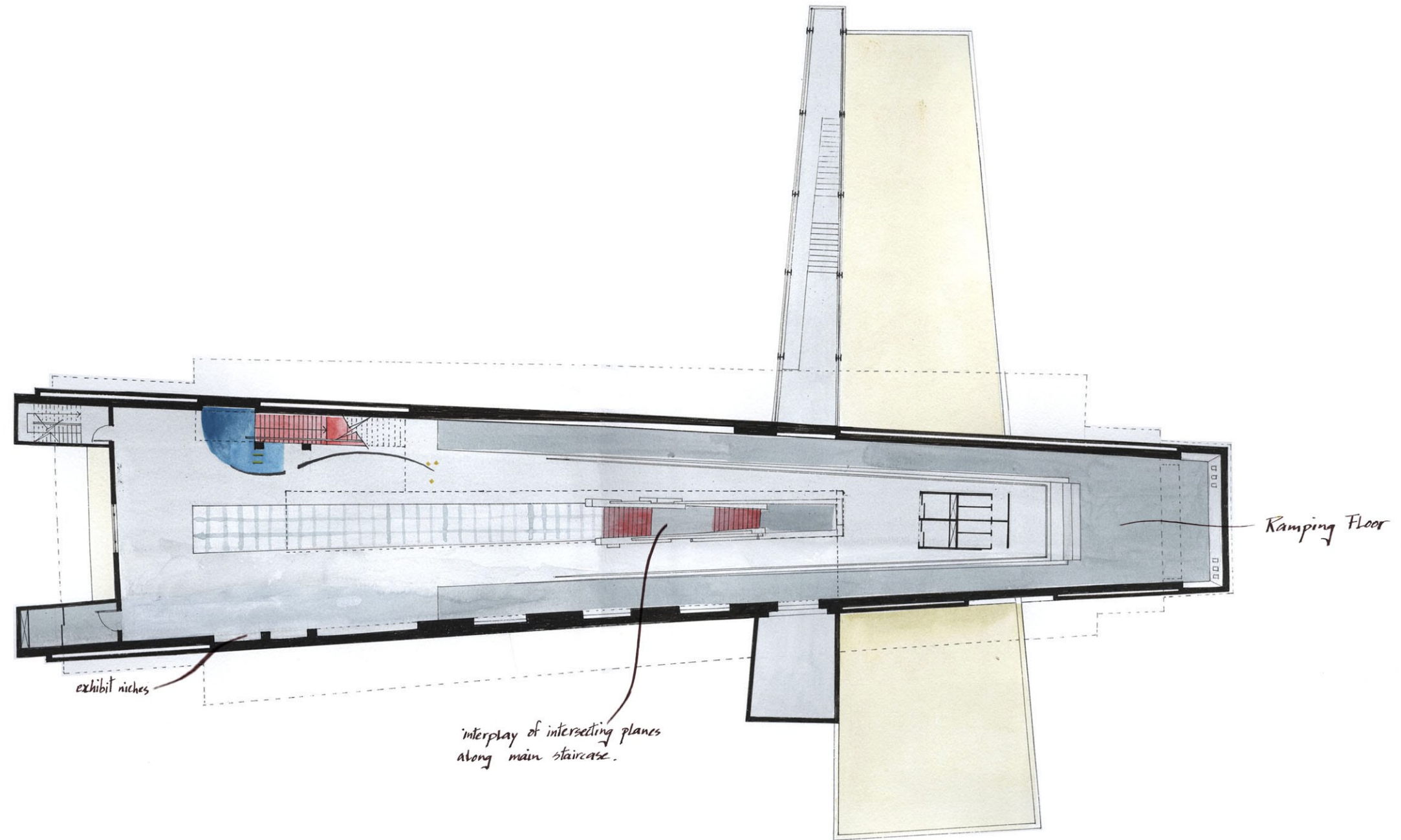

SECOND FLOOR PLAN  
الطابق الثاني

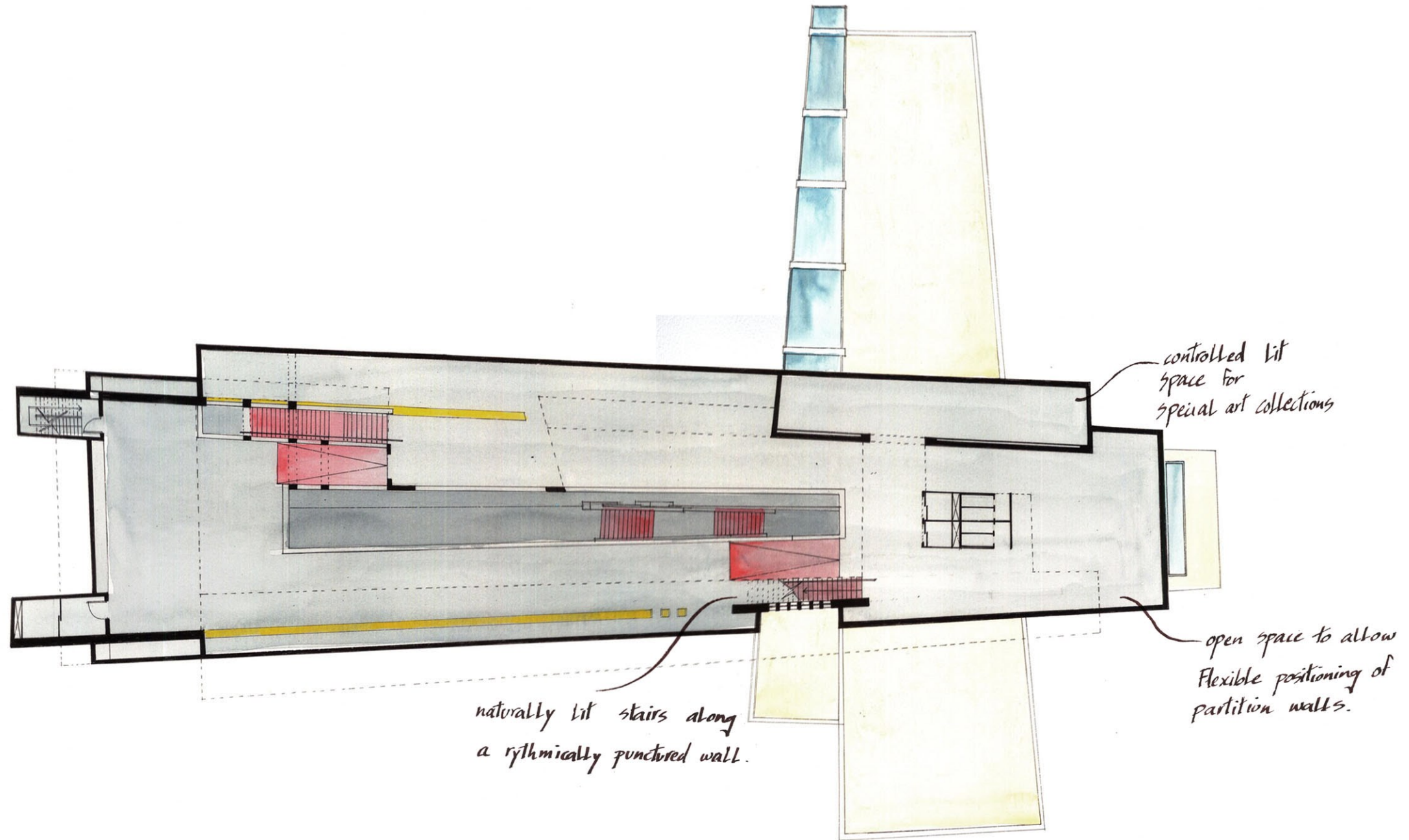

THIRD FLOOR PLAN  
الطابق الثالث



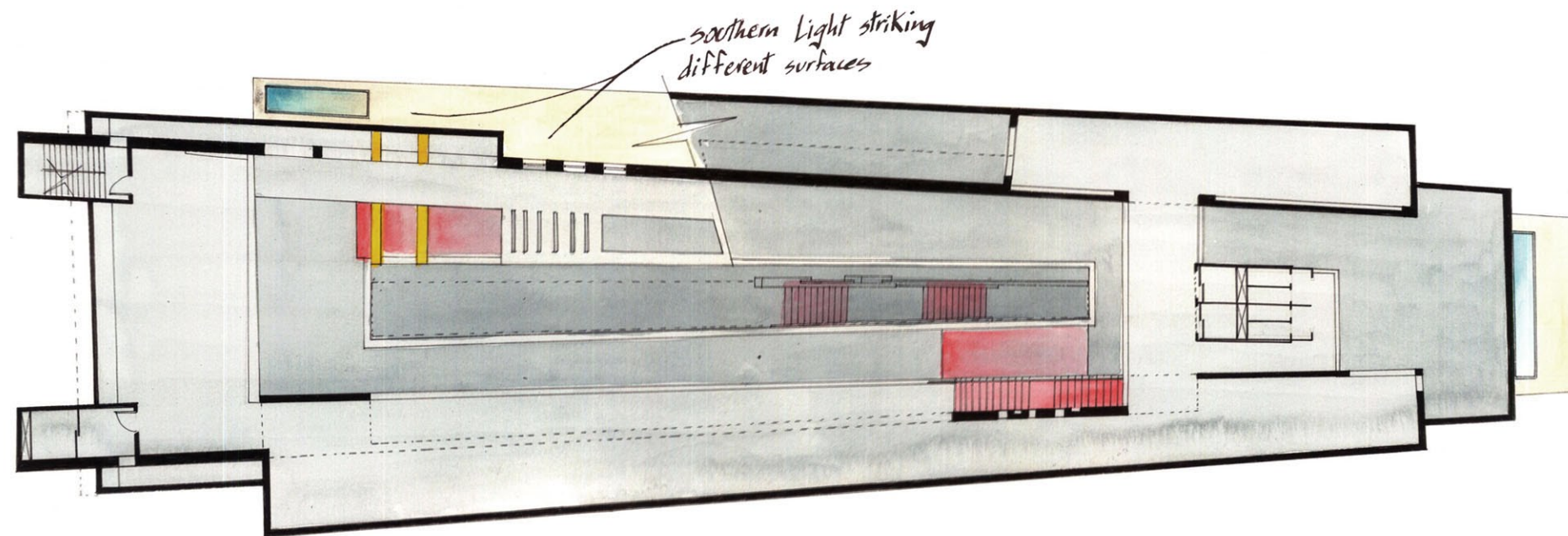

Linear exhibition space showing glimpses of spaces below

FOURTH FLOOR PLAN  
الطابق الرابع

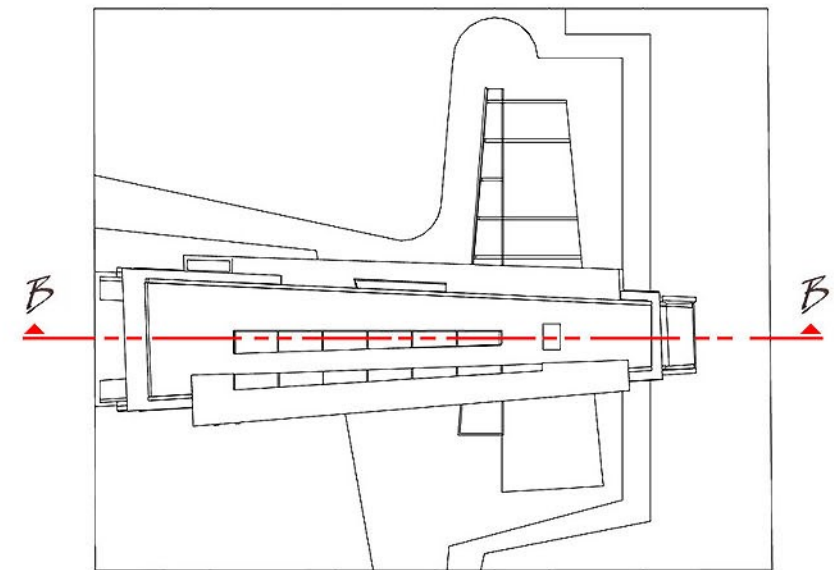
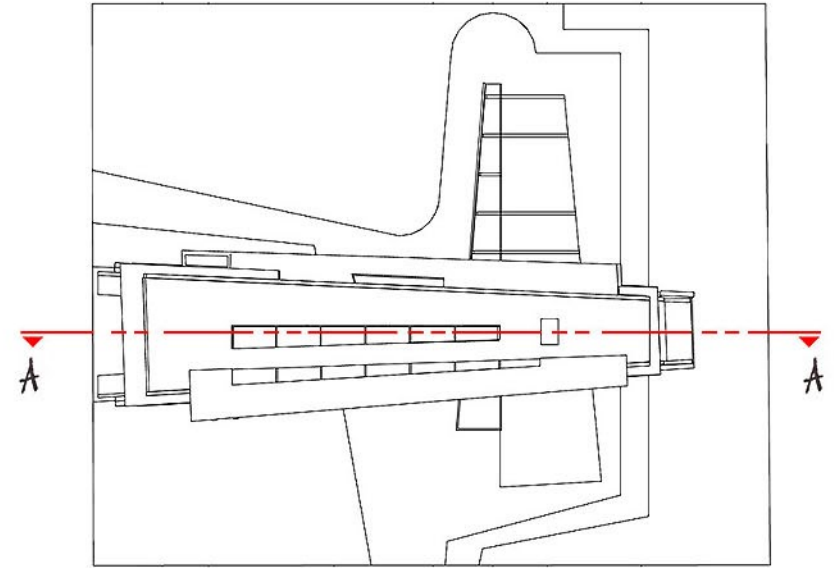



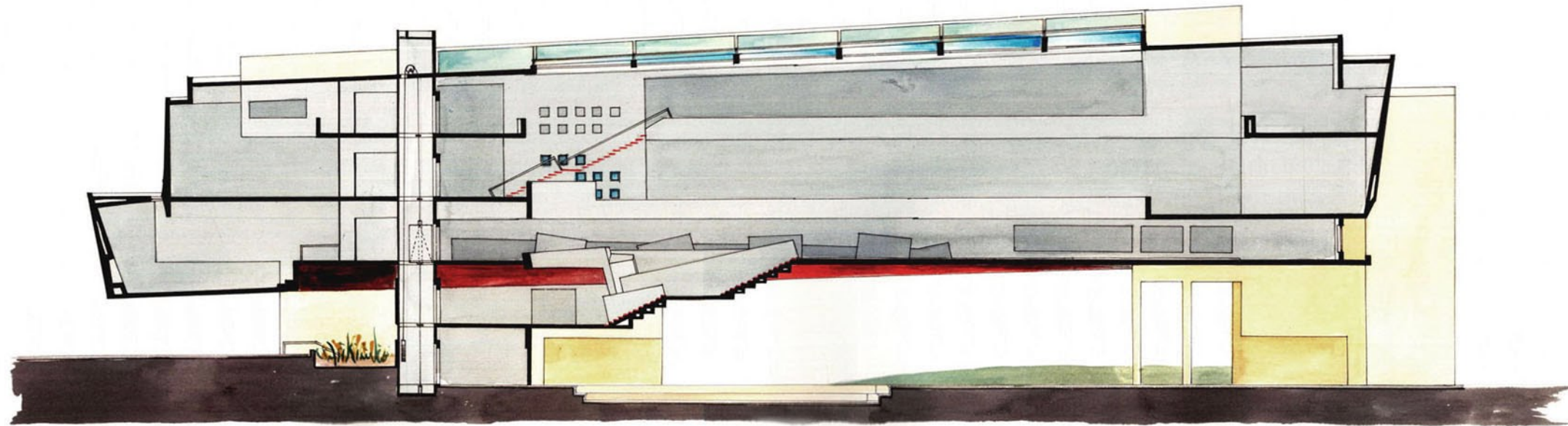

Section A-A showing opening up of levels

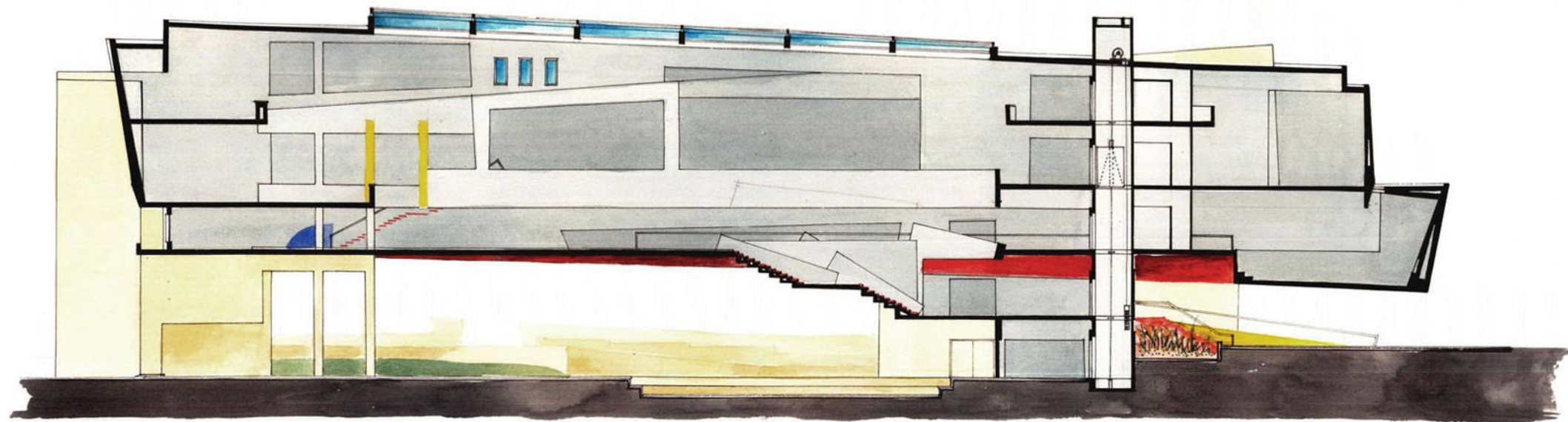

Section B-B showing how cantilevering spaces meet with the parent space.

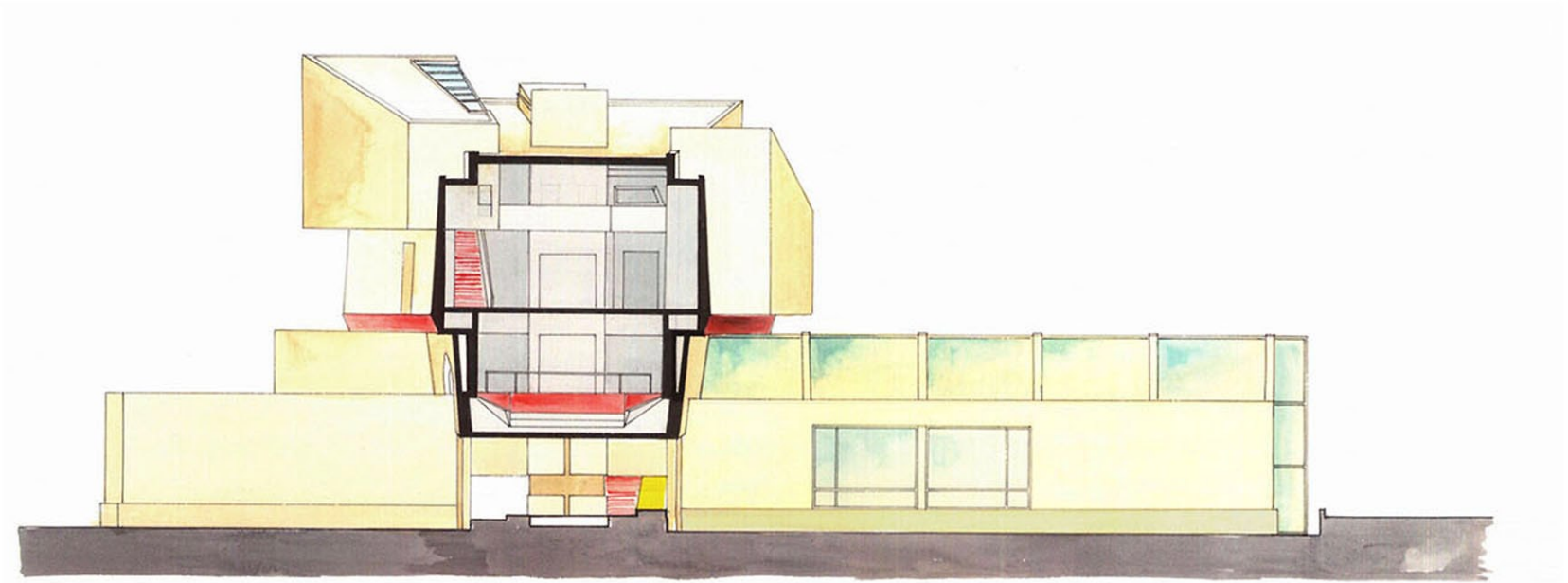
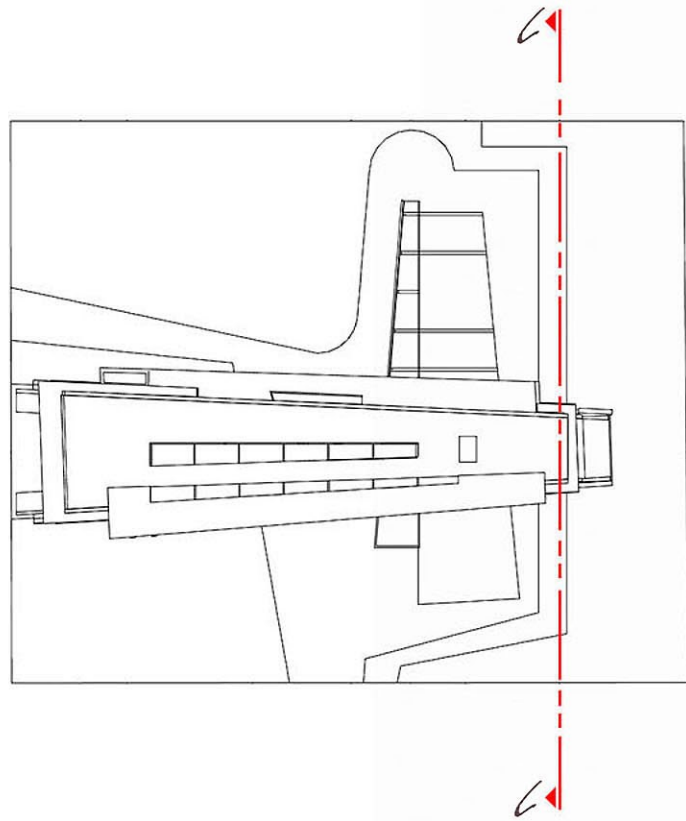

Section C-C highlighting the cantilevering part over the main entrance.

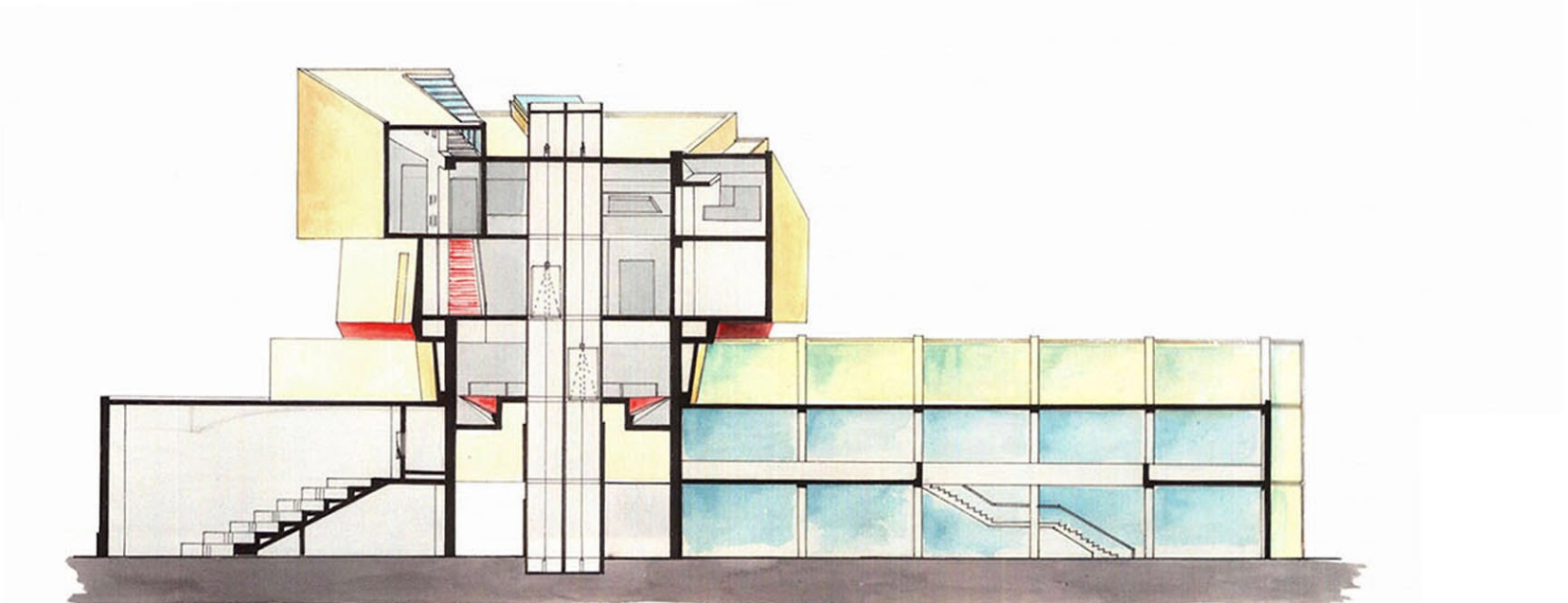
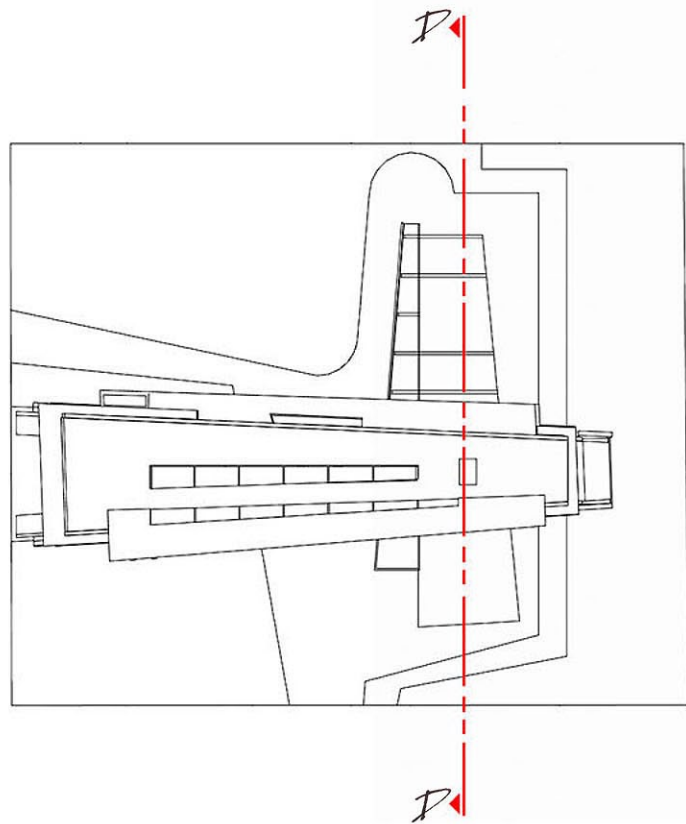

Section D-D indicating the different structural systems in both the elevated and ground buildings



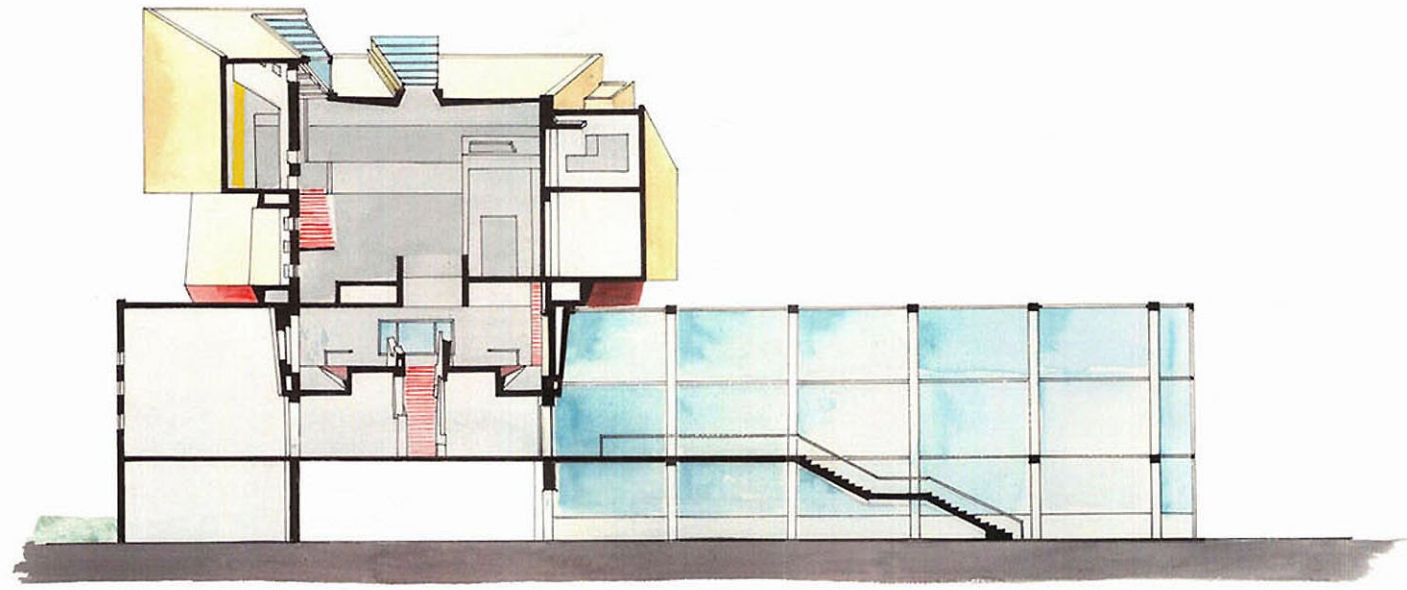
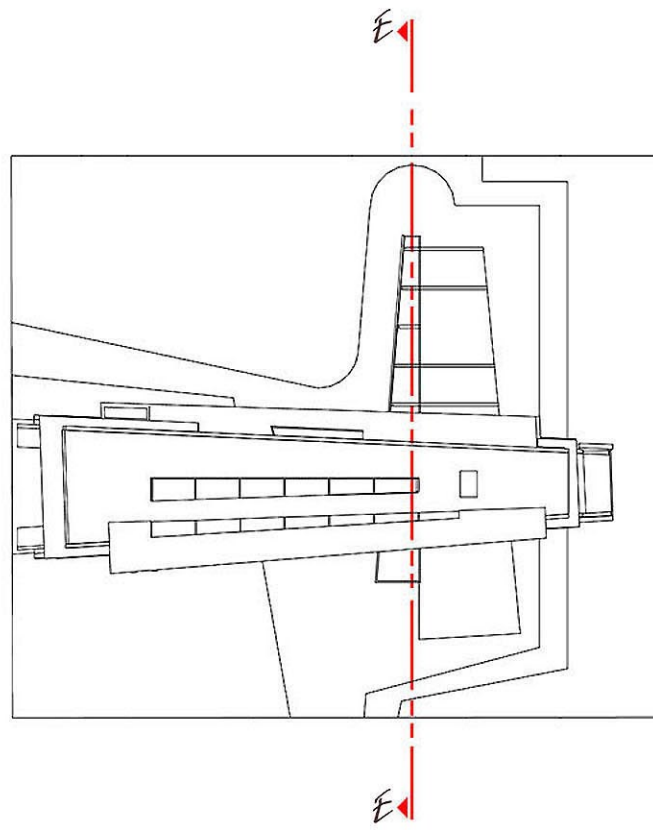

Section E-E cutting through skylights and openings. Glass wall leading to sculpture garden.

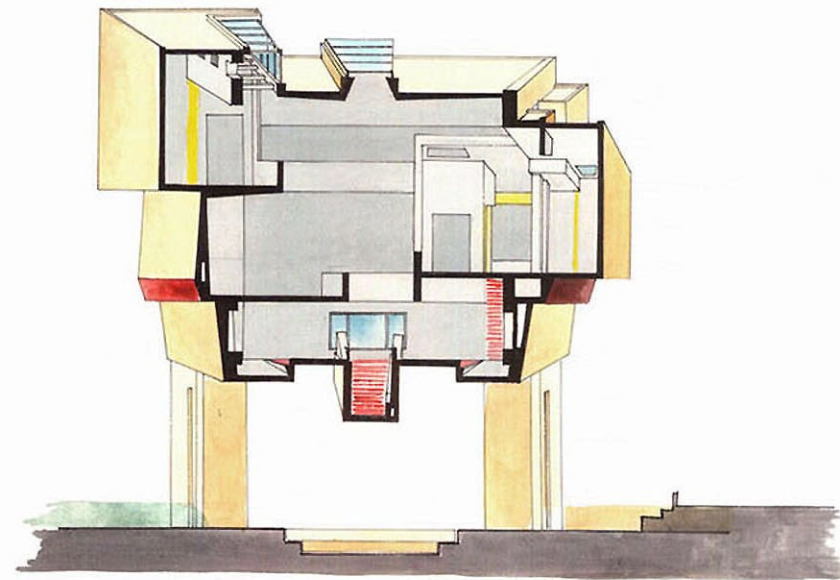
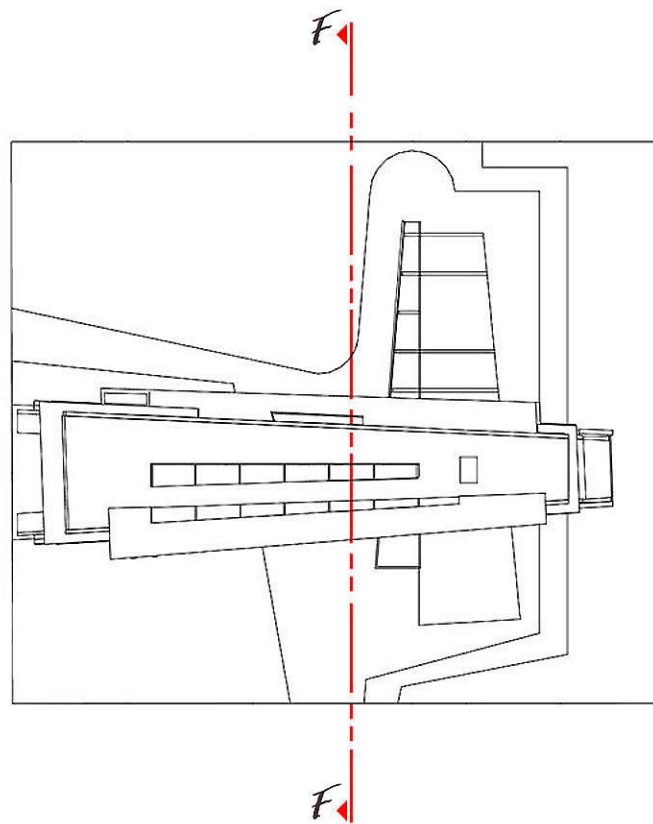

Section F-F The interior widens with more visual interaction between intersecting spaces.

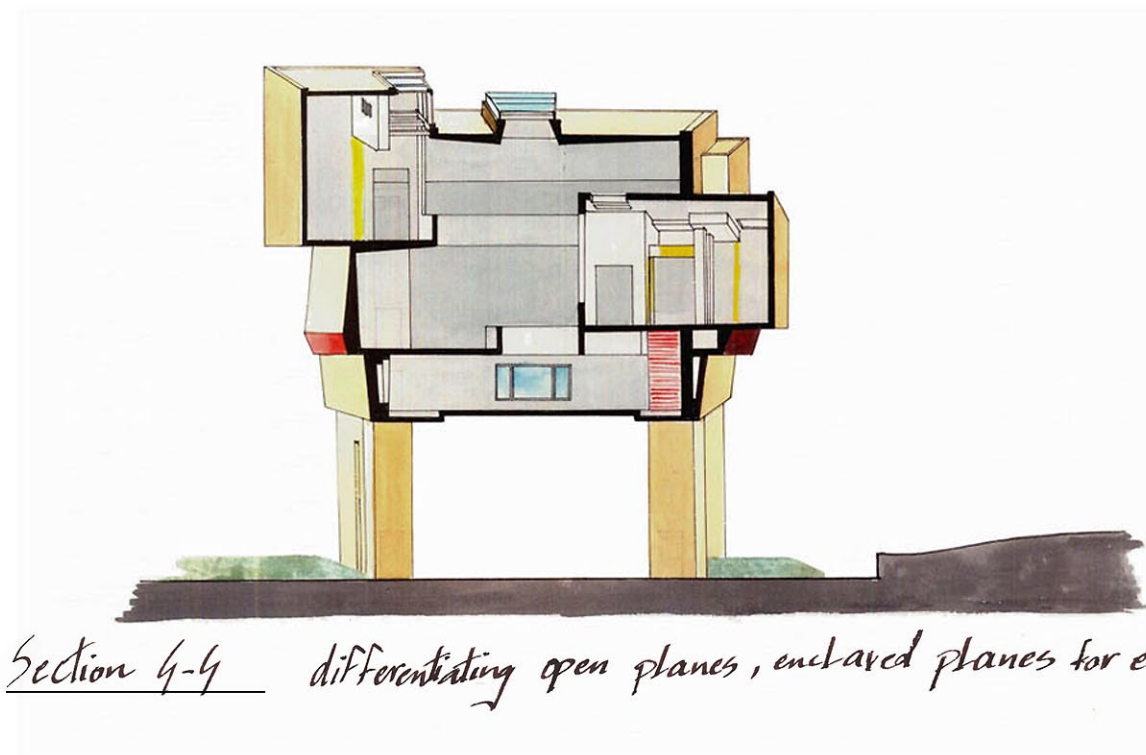
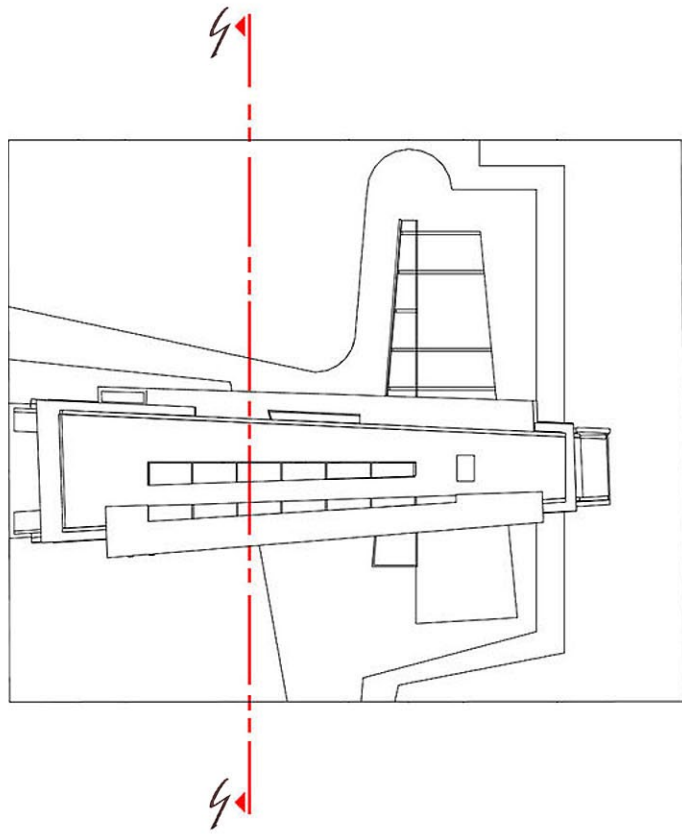

Section 4-4 differentiating open planes, enclosed planes for exhibits, double walls containing ducting.

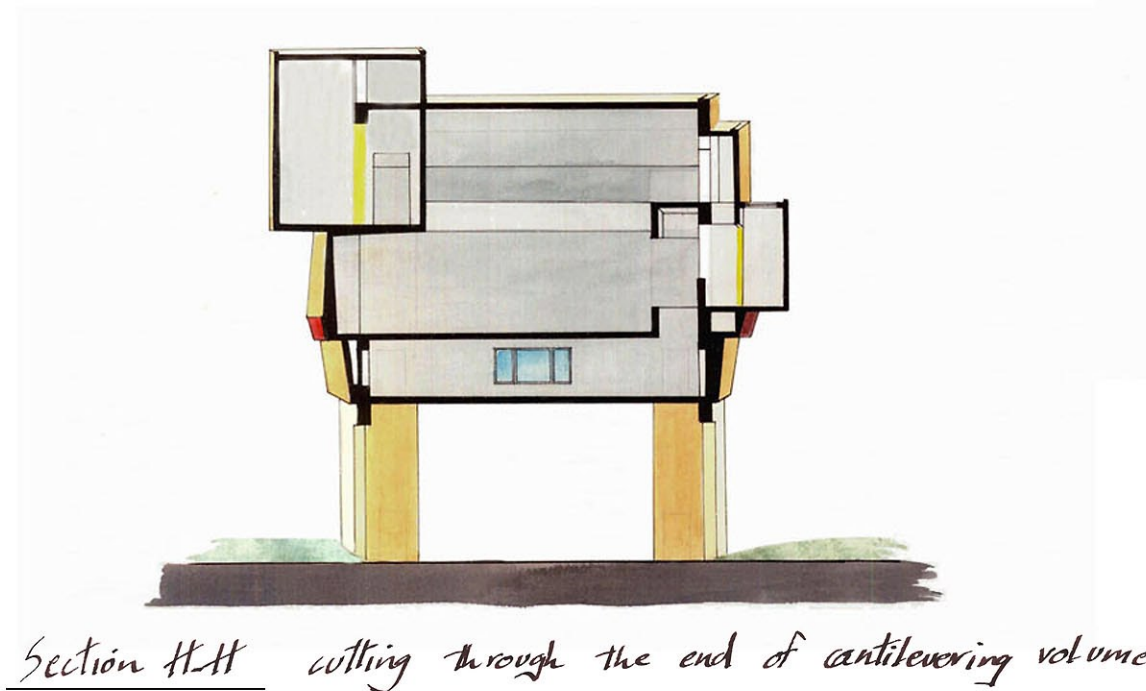
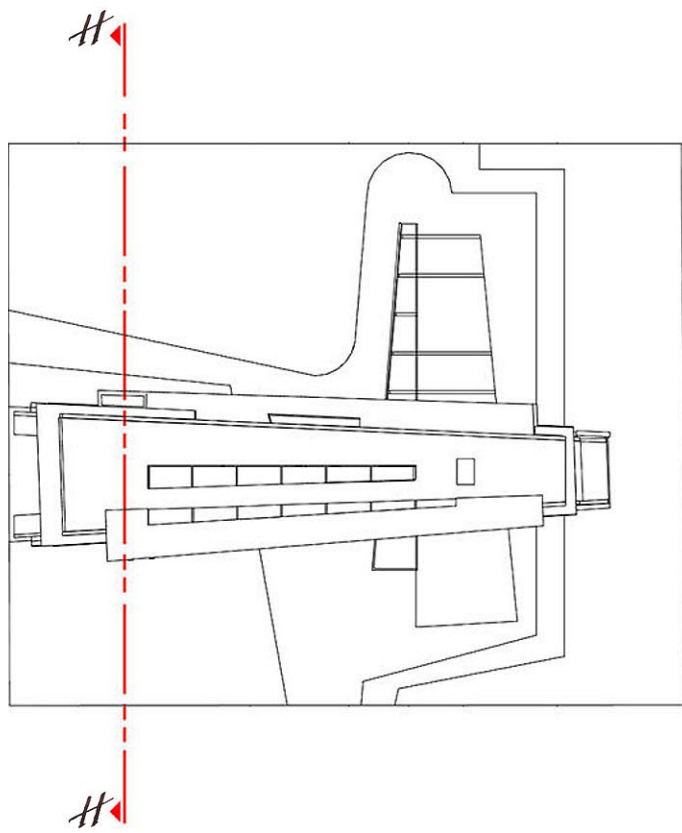

Section H-H cutting through the end of cantilevering volumes.



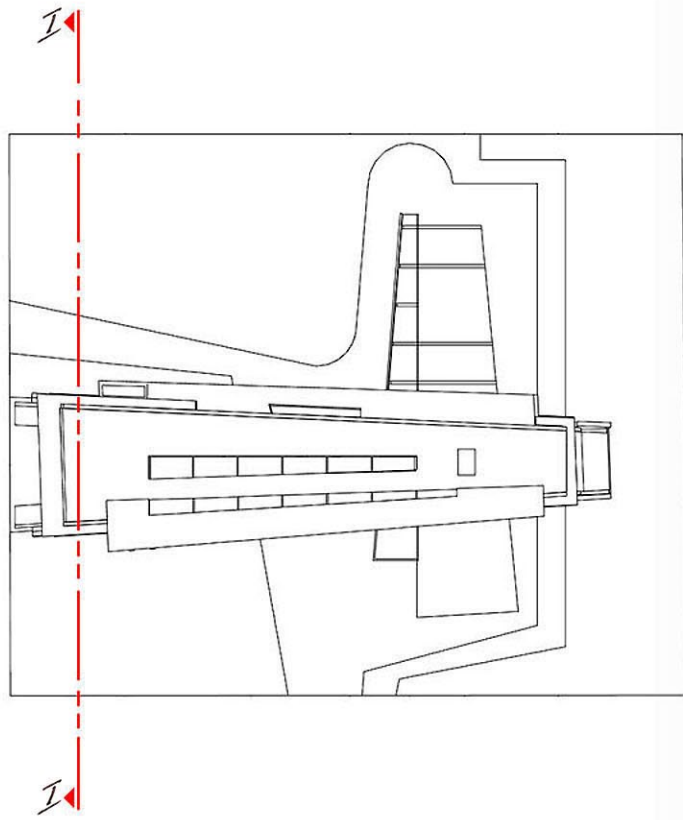

Section I-I showing the highest wall area for exhibits on top two levels.

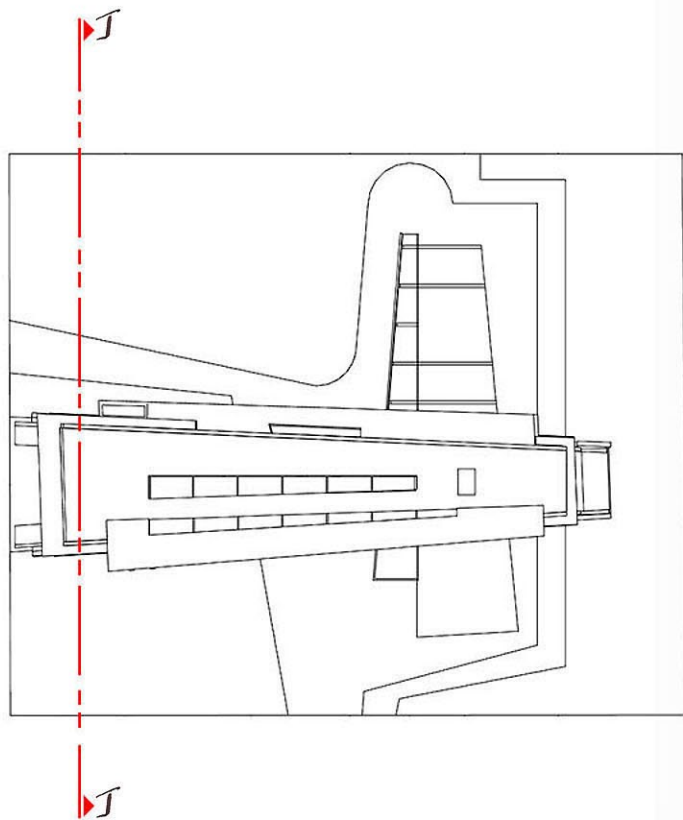

Section J-J showing the meeting of the different slopes.



## FINAL THOUGHTS

Creativity can only be unleashed by allowing the unconscious world of thoughts to exist within the conscious world of physicality, wherein to design an architectural project is analogous to painting, both bound by the inevitable need to deal with material and medium to express the idea. The final communication of the idea includes a sensual dimension, in addition to its mental comprehension, only when the artist's and architect's joy transpires through the making of their work.

Kandinsky's painting reveals the enjoyment of the artist in producing that painting, touching the canvas and immersing himself in colors. That is something I tried to do literally by painting the drawings for my project. To draw and paint in watercolors made me closer to my work and perceptually heightened my understanding of the physical aspects of the building in its tactility and sensuality.

Architecture as a discipline poses a lot of questions in trying to understand its nature and credibility as a contributory discipline to the aesthetic world of the senses. In my opinion, the autonomous discipline of architecture draws strength from an introspective nature, reflecting upon non-architectural streams of thought from art to literature to philosophy and others. In this thesis, I tried to explore the connections an artist and an architect share where each expresses in their own way and medium. I started with an emotional affinity for a painting and followed my intuition to architectural fruition. Donald Judd says: 'Thought without feeling would not have the force of hypotheses'<sup>(3)</sup>, and that is exactly what makes an idea so powerful and potent.

The 'inner necessity' of the artist and the architect is what paves the way for subjective reflection and creative exploration of ways to translate an impulse into feeling, and then into thought, and finally into presence. In architecture, such attempt is explained by George Simmel (1911): 'Architecture is the only art in which the great struggle between the will of the spirit and necessity of nature issues into real peace, in which the soul in its upward striving and nature in its gravity are held in balance'<sup>(4)</sup>.

<sup>(3)</sup> Donald Judd, 'Donald Judd / edited by Nicholas Serota', New York : D.A.P., 2004. Page (39)

<sup>(4)</sup> Allan Doig, 'Theo Van Doesburg: Painting into architecture, theory into practice', Cambridge [Cambridgeshire] ; New York : Cambridge University Press, 1986. Page (19)



## **BIBLIOGRAPHY**

Thomas M. Messer, 'Vasily Kandinsky', New York: H.N. Abrams, 1997.

Allan Doig, 'Theo Van Doesburg: Painting into architecture, theory into practice', Cambridge [Cambridgeshire] ; New York: Cambridge University Press, 1986.

Donald Judd, 'Donald Judd / edited by Nicholas Serota', New York: D.A.P., 2004.

Wassily Kandinsky, 'Kandinsky, complete writings on art / edited by Kenneth C. Lindsay and Peter Vergo.', Boston, Mass.: G.K. Hall, c1982.

## **ACKNOWLEDGEMENTS**

I would like to express my gratitude toward my thesis committee: William Galloway, Hans Rott, and Steven Thompson for their devotion and constant bettering of the project.

I would like to thank my family and friends for their support and encouragement.