

TECHNOLOGICAL INNOVATION IN FOREST HARVESTING

by

Nancy Farm Mannikko

Thesis submitted to the Faculty of the  
Virginia Polytechnic Institute and State University  
in partial fulfillment of the requirements for the degree of  
Master of Science  
in  
Science and Technology Studies

APPROVED:



---

Joseph C. Pitt, Chairman

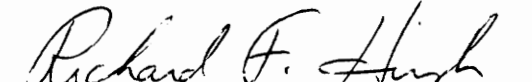

---

Richard F. Hirsh

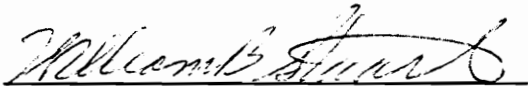

---

William B. Stuart

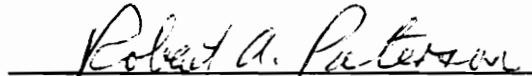

---

Robert A. Paterson

April 11, 1990  
Blacksburg, Virginia

C.2

LD  
5655  
V855  
M366  
1990  
C.2

# TECHNOLOGICAL INNOVATION IN FOREST HARVESTING

by

Nancy Farm Mannikko

Joseph C. Pitt, Chairman

Science and Technology Studies

(ABSTRACT)

Scholars in science and technology studies have long been concerned with a variety of issues revolving around technological change, such as explaining the origins of technological innovation and arguing for or against technological determinism. This thesis reviews a number of theoretical models developed by historians, philosophers, sociologists, and other scholars to explain technological change. A case study of technological innovations in industrial forestry and timber harvesting practices provides a basis for a critique of these previously proposed models and for an argument for a new model. This model, an ecological model, suggests homeostatic pressures play a major role in the innovative processes within any technological system.

# Acknowledgements

I would like to thank the members of my committee -- Richard Hirsh, Robert Paterson, Joseph Pitt, and William Stuart -- for their assistance in preparing this thesis. Special thanks to Dr. Stuart for his help in opening doors within the industry and to Dr. Pitt for his patience. I would also like to acknowledge the cooperation and assistance of the people who really made this thesis possible. Without the information and documentation generously provided by the American Pulpwood Association, Pettibone-Michigan, Franklin Equipment Company, George and Barbara La Tendresse, Hubert Moberg, Reino Lahti, John Mihelich, and the numerous other people who cheerfully shared their memories of the early days of mechanization in industrial forestry this thesis would have been both less interesting and less complete. Special thanks to my officemates, Teresa Castelao, Garritt Curfs, and Stephan Castonguay, well as to the other graduate students in Science and Technology Studies, Sociology, History, and Forestry, who, through their generosity and helpful hints, proved that an interdisciplinary approach is possible in practice as well as in theory.

Last but definitely not least, I would like to thank my family: my husband, Raymond, and younger daughter, Tamar, for humoring me as I struggled to complete a thesis on a topic that neither of them has any interest in whatsoever, and my older daughter, Zuleika, for providing a distraction -- a grandchild -- to remind me there is life outside of graduate school.



# Table of Contents

**Introduction** ..... 1

**Chapter One: Science, Technology, and Timber Harvesting** ..... 3

**Chapter Two: A Review of Explanatory Schema** ..... 15

**Chapter Three: A Brief History of Logging** ..... 23

**Chapter Four: Winds of Change** ..... 42

    The Call for Rationalization in the Woods ..... 43

    The Drott Loader ..... 45

    The Possible Role of Popular Periodicals ..... 48

    The Availability of Vocational Education ..... 52

    Systemic Inertia ..... 53

    Philip La Tendresse and the Pettibone Cary-Lift ..... 61

    Logging Tractors ..... 72

**Chapter Five: Conclusions** ..... 79

**Appendix A. Pettibone Super 30 Cary-Lift 1989** ..... 87

**Appendix A. Franklin 105 Grapple Skidder M-28 1990** ..... 90

**Appendix B. Glossary** ..... 93

**Bibliography** ..... 97

**Vita** ..... 105

# List of Illustrations

Figure 1. Raker teeth on saw blades. . . . .	7
Figure 2. The five phases of logging. . . . .	8
Figure 3. Big wheels. . . . .	9
Figure 4. Cant hooks and peaveys. . . . .	13
Figure 5. A Barnhart loader c.1900. . . . .	27
Figure 6. A North Bend cable yarding system. . . . .	29
Figure 7. A suggested logging camp layout. . . . .	32
Figure 8. Horse-powered cable jammer. . . . .	33
Figure 9. Hand loading pulpwood in Canada. . . . .	34
Figure 10. Steam tractor c.1885. . . . .	39
Figure 11. The Drott Loader. . . . .	46
Figure 12. A skid loader. . . . .	47
Figure 13. Conventional forklift. . . . .	49
Figure 14. Loaders built by a Utah high school shop class. . . . .	50
Figure 15. Kendall jammer. . . . .	55
Figure 16. Cable yarding systems. . . . .	56
Figure 17. Toploading logs in 1950. . . . .	57
Figure 18. Toploading logs at the turn of the century. . . . .	58
Figure 19. The Timberland Timber Tosser. . . . .	60
Figure 20. The first Carry-Lift. . . . .	64
Figure 21. The first production model Cary-Lift. . . . .	65

Figure 22. Muscle shot for advertising purposes. . . . .	66
Figure 23. The first Carry-Lift equipped with a swivel clam. . . . .	68
Figure 24. A railroad frog. . . . .	70
Figure 25. Early model Franklin logging tractor. . . . .	74
Figure 26. Early model Franklin logging tractor. . . . .	75

# Introduction

The history of industrial forestry and forest harvesting in the United States and Canada is not one of dramatic overnight developments and sudden changes. It is instead one of gradual evolutions; gradual, that is, until the decade following World War II. In 1879 woodworkers had harvested the timber from Michigan's white pine forests using crosscut saws and human muscle. Seventy years later, in 1949, science had split the atom, aircraft were flying at supersonic speeds, and Milton Berle had begun his television career, but most woodworkers were still harvesting timber using cross cut saws and human muscle. After a brief flurry of innovations in the 1880s -- the raker tooth, the big wheel, cable jammers and railroad logging<sup>1</sup> -- the industry entered a prolonged period of involuntary technological stasis.<sup>2</sup> for mechanization and improved production methods existed but for a variety of reasons tangible results were few and far between. Then, in the early 1950s, industrial forestry in the Lake States experienced a series of sudden changes. An industry which Stewart H. Holbrook and others have characterized as being notoriously conservative and resistant to change went from being highly labor intensive to highly mechanized

---

<sup>1</sup> See Rolland H. Maybee, *Michigan's White Pine Era 1840-1900* (Lansing, MI: Michigan State Historical Society, 1976); and John Emmett Nelligan, *A White Pine Empire: The Life of a Lumberman* (St. Cloud, MN: North Star Press, 1969).

<sup>2</sup> For a thorough discussion of the concept of technological stasis, see Richard F. Hirsh, *Technology and Transformation in the American Electric Utility Industry* (Cambridge: Cambridge University Press, 1989), pp. 189-92.

in a dramatically short period of time.<sup>3</sup> This transformation of the logging industry, from labor intensive to mechanized, was neither smooth nor easy, nor did it proceed at equal rates in all regions of the United States and Canada.

In this thesis I discuss changes which occurred following World War II, the changes which resulted in the industry finally succeeded in distancing the worker from the tree. I begin in Chapter One by showing why a study of technological change in industrial forestry practices is relevant to science and technology studies. Chapter Two contains a review of models developed by historians, sociologists, economists, and philosophers to explain technological change in other industries to determine which, if any, might be applicable to logging. In Chapter Three I explore possible causes for the prolonged technological stasis in industrial forestry and then in Chapter Four describe the changes the commercial timber harvesting industry experienced when this stasis ended. I argue that the pattern of development for two devices, the Pettibone Cary-Lift and the Franklin logging tractor,<sup>4</sup> can be seen as representative of the pattern of development for the many other innovations which occurred in the period following World War II and which had the cumulative effect of radically transforming the entire technological system. Finally, in Chapter Five I argue in conclusion that the patterns of diffusion and of technological change within the overall system that industrial forestry and timber harvesting are components of can be used both to illustrate the weaknesses of previously proposed models and as a basis for a new model, an ecological model which considers the homeostatic mechanisms of that system.

---

<sup>3</sup> See Stewart H. Holbrook, *Holy Old Mackinaw: A Natural History of the American Lumberjack* (New York: MacMillan, 1953); Ian Radforth, *Bushworkers and Bosses* (Toronto: University of Toronto Press, 1987); or M. H. Collet, "Pulpwood Production Tools," *Paper Trade Journal* November 1945:1203-6+.

<sup>4</sup> These two devices were selected to serve as exemplars because one, the Cary-Lift, occurred at the beginning of this period of rapid change and embodied many firsts, e.g., an extended reach hydraulic fork, while the other, the Franklin logging tractor, appeared at the end.

# Chapter One: Science, Technology, and Timber

## Harvesting

Logging presents an especially rich field for the scholar in science and technology studies to explore. Although the activities of industrial forestry and the commercial forest products industries affect all segments of our society, scholars have paid scant attention to timber harvesting in the past. While a rich folklore tradition exists, e.g., the Paul Bunyan fables popular in the Midwestern United States, scholarly literature detailing the history or impact of technological innovations in industrial forestry practices is extremely sparse, as indeed are histories of a more general nature. Given the intimate and increasingly controversial relationship between society as a whole and commercial forestry activities,<sup>5</sup> this neglect of logging by scholars represents a serious lacuna in technology studies as a whole.

Logging histories enjoyed a brief vogue in the 1930s when the profile of the typical lumberjack was changing and many oldtimers wrote their memoirs or mourned the passing of the Paul Bunyans of the past -- e.g., Holbrook and Nelligan -- but have been infrequent since then.<sup>6</sup> Most recent

---

<sup>5</sup> For example, on March 4, 1990, a segment of the CBS news program, "Sixty Minutes," reported on efforts of a group of radical environmentalists, Earth First, to sabotage logging operations.

<sup>6</sup> The American populace in the 1930s was apparently more interested in logging than it has been during any decade before or after. Numerous versions of the Paul Bunyan tales were published in editions aimed both at children and adult readers, book length nonfiction logging histories and memoirs were popular,

work, such as Ian Radforth's *Bushworkers and Bosses*, Richard Rajala's "Bill and the Boss: Labor Protest, Technological Change, and the Transformation of the West Coast Logging Camp, 1890-1930," *Journal of Forest History* October 1989:168-79, and Debra Bernhardt, "Ballad of a lumber strike," *Michigan History* 62.1(1982):38-43, focuses on labor history. In addition, although Radforth, Bernhardt, and Rajala all see technological change as having played an important role in labor relations in industrial forestry, they disagree on several key issues.

Bernhardt, for example, sees technological change as having defused the labor tensions in Michigan's Upper Peninsula through its weakening effects on worker autonomy. In "Ballad of a lumber strike" Bernhardt describes the tense and occasionally violent confrontations between woodworkers and management in the late 1930s and concludes that technological innovations such as the introduction of mechanized equipment, i.e., "the introduction of the one-man power saw,"<sup>7</sup> reduced manpower requirements and weakened the union's bargaining power. This would be an example of a classic demand pull of the market place in that labor unrest created a need for machines to replace workers, and this may contain some elements of truth. However, this labor unrest was not strictly a phenomenon of the 1930s nor of the upper Midwest. Labor unrest coupled with numerous strikes was an ongoing feature of industrial forestry across the northern United States and Canada beginning with organizing efforts by the Industrial Workers of the World (IWW), in 1917 and, as Radforth shows, continuing until quite recently.<sup>8</sup> In addition, Bernhardt's analysis of the impact of the technological changes is seriously flawed -- the one-man power saw, for example, was not widely available until the early 1950s, more than a decade after the strikes she describes ended.<sup>9</sup>

Rajala, in contrast to Bernhardt, sees technology not as having reduced labor strife but instead as engendering or contributing to it. Rajala argues that technological changes required hiring

---

and articles and stories about logging were frequent features in periodicals such as *The Saturday Evening Post* and *Literary Digest*.

<sup>7</sup> Bernhardt, p. 43

<sup>8</sup> See Radforth, pp. 234-36, for a description of Lumber and Saw's 1978 strike against Boise Canada.

<sup>9</sup> See Ellis Lucia, "A lesson from nature: Joe Cox and his revolutionary saw chain," *Journal of Forest History* 25.3(1981):158-65.



woodworkers who possessed greater skills than the lumberjacks of earlier time periods. These more highly skilled workers thus enjoyed a freedom of mobility in selecting jobs and that mobility led to improving camp conditions as employers attempted to reduce employee turnover. Rajala posits that the introduction of high lead yarding after the turn of the century was a key factor in empowering the workers and increasing their autonomy. Faced with these skill requirements combined with the militant industrial unionism of groups such as the Industrial Workers of the World (IWW), forced to improve dramatically the living conditions for woods workers.

Tempting though it is to agree with Rajala's crediting high-lead yarding with worker empowerment, his argument contains several flaws. Not only did all woods work, not just high-lead yarding, require skills that could take many months to acquire, but woods work in areas where cable yarding, i.e., high lead and sky-line systems, was not utilized also experienced labor unrest and changes in industrial relations during this same time period.<sup>10</sup>

Radforth presents a more balanced picture, and argues that mechanization was both strike generating and union busting. At the same time, the picture that emerges in *Bushworkers and Bosses* is not so much one of an industry responding to worker demands as it is one of an industry reacting to a labor shortage. The most violent labor-management confrontations occurred in the 1930s, but, according to Radforth, mechanization of the Canadian forestry industry did not truly begin until the 1950s. Commercial forestry in Canada apparently took over twenty years to respond to its problems with labor by introducing a higher degree of mechanization. Like logging companies in the Midwest and the Pacific Northwest, Canadian firms first attempted to improve the living conditions and only later began to change the nature of the work itself.

An examination of trade publications, moreover, supports a conclusion that the majority of significant innovations occurred after World War II. Articles in trade journals printed between 1912 and 1950 predominately refer to suggestions for improving logging camp living conditions, not

---

<sup>10</sup> See Radforth, pp. 106-78; Joseph Conlin's "Old boy, did you get enough of pie? A social history of food in logging camps," *Journal of Forest History* October 1979:164-85; E. Newton-White, "Trouble in the woods," *Canadian Forum* 14(July 1934):383-84; "Lumber strike," *Business Week* May 18, 1935:10; and "Again -- trouble in lumber camps," *Business Week* October 19, 1940:26+.

reports on new or improved harvesting equipment.<sup>11</sup> Prior to the war, logging methods remained static for almost a century. The few innovations which did occur, such as the development of the raker tooth for crosscut saws in the 1880s (See Figure 1 on page 7),<sup>12</sup> increased production but did not alter the essentially highly labor intensive nature of all five phases of the industry (See Figure 2 on page 8).<sup>13</sup>

In addition to having mechanized very recently compared to other industries, including the other extractive industries such as agriculture and mining, forestry remains extremely diversified in its patterns and degrees of mechanization. Textbooks in industrial forestry make it quite clear there is no nationally or even regionally standardized way of performing harvesting operations.<sup>14</sup> It has been posited that a key difference between science and technology lies in the noncumulative nature of technology. As Joseph Agassi notes, the implementation of a new technology frequently means abandoning an old one, and with it all the skills and craft it entailed.<sup>15</sup> If this is true, then logging may be of particular interest because many of the old technological skills have not been abandoned. Because the extent to which new technologies have been adopted varies widely even within limited geographic areas, it is possible to find old techniques being used within a few miles of a technology

---

<sup>11</sup> See "Mobile logging camp built on flat-cars," *Engineering News-Record* 78(June 14, 1917):570; or "Railway coaches equipped as camp buildings for lumber crew," *Engineering Record* 75(January 13, 1917):67. Conlin's "Old boy, did you get enough of pie? A social history of food in logging camps," provides a detailed and fascinating look at the importance of the camp cookhouse for a successful logging operation prior to mechanization.

<sup>12</sup> Maybee credits the combination of the invention of the raker tooth and the big wheel (See Figure 3 on page 9) with the rapid decimation of the white pine forest in the upper Midwest. In the 1870s the lumbermen thought the forests would last for at least another hundred years. By the turn of the century only stumps remained. See Holbrook, 1953, pp. 72-118.

<sup>13</sup> These five phases of forest harvesting are felling, in-woods processing, in- woods transport, loading, and hauling the product to market. See Steve Conway, *Logging Practices: Principles of Timber Harvesting Systems*(Miller Freeman Publications, 1976), pp.48-60; George Stenzel, Thomas A. Walbridge Jr., and T. Kenneth Pearce, *Logging and Pulpwood Production*, second edition (New York: John Wiley & Sons, 1985), pp.180-319; and W. S. Bromley, *Pulpwood Production* (Danville, IL: Interstate Publishers, 1969), pp. 117-212, for a discussion of contemporary forest harvest methodologies.

<sup>14</sup> See Bromley, Conway, or Stenzel.

<sup>15</sup> See Joseph Agassi, *Technology: Philosophical and Social Aspects* (Dordrecht: D. Reidel Publishing Company, 1985), pp. 16-26; Henryk Skolimowski, "The structure of thinking in technology," pp. 42-49 in Carl Mitcham and Robert Mackay, eds., *Philosophy and Technology* (New York: The Free Press, 1972); and I. C. Jarvie, "The social character of technological problems: comments on Skolimowski's paper," pp. 50-53 in Carl Mitcham and Robert Mackay, eds., *Philosophy and Technology* (New York: The Free Press, 1972).

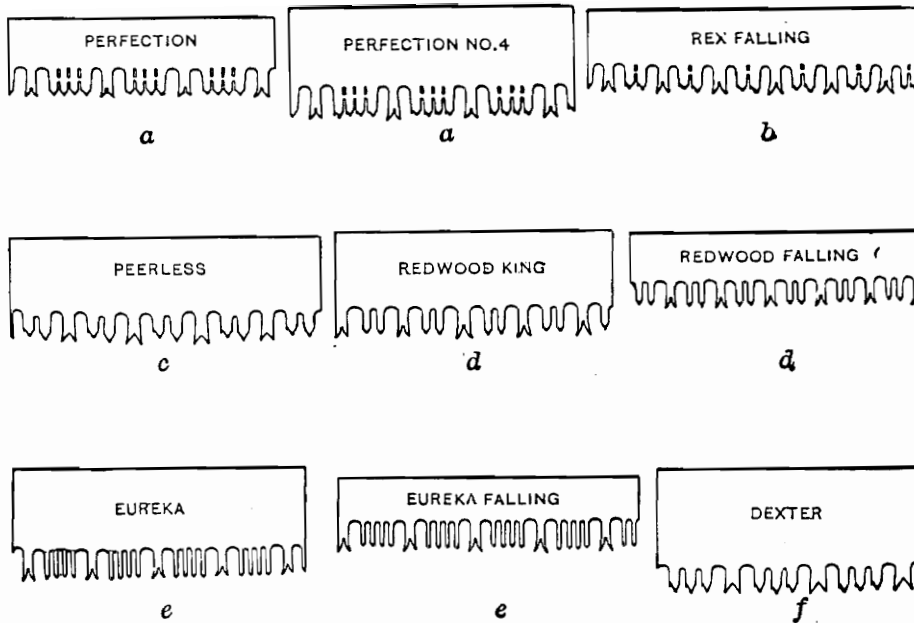

Saw Teeth Patterns. *a.* Often used for sawing southern yellow pine, cypress and spruce. *b.* For sawing white pine, hemlock and cedar. *c.* For sawing yellow poplar and cottonwood. *d.* For sawing redwood. *e.* For sawing Douglas fir. *f.* For sawing white oak.

(From Ralph Clement Bryant, *Logging* (New York: John Wiley & Sons, Inc., 1923), p. 85.)

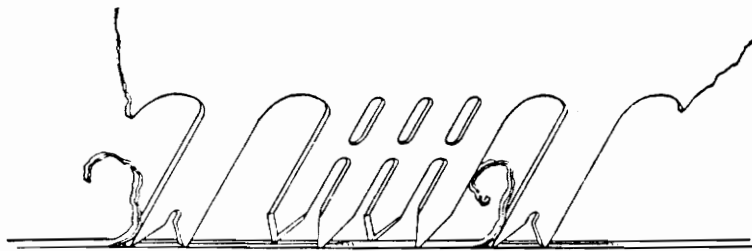

Sketch illustrating operation of the cutting and raker teeth on a cross-cut saw. The four cutting teeth shown in the center are slightly longer than the raker teeth.

(From Nelson Courtland Brown, *Logging -- Principles and Practices in the United States and Canada* (New York: John Wiley & Sons, 1934), p. 78.)

Figure 1. Raker teeth on saw blades.

PHASES AND FUNCTIONS OF HARVESTING OPERATIONS

P H A S E S	F U N C T I O N S
I. FELLING or severing the tree	Felling
II. PROCESSING the tree to a form suitable for transport	Limbing Measuring Bucking Topping Slashing Debarking Chipping Screening
III. IN-WOODS TRANSPORT or MOVING the tree or tree segment from the stump to a collection point	Piling Bunching Skidding Forwarding Yarding
IV. LOADING the product onto hauling vehicle	Sorting In-woods Loading Off-Loading at Landing Loading of Haul Truck
V. HAULING the product to various markets	Hauling Unloading Scaling or Weighing

Figure 2. The five phases of logging.

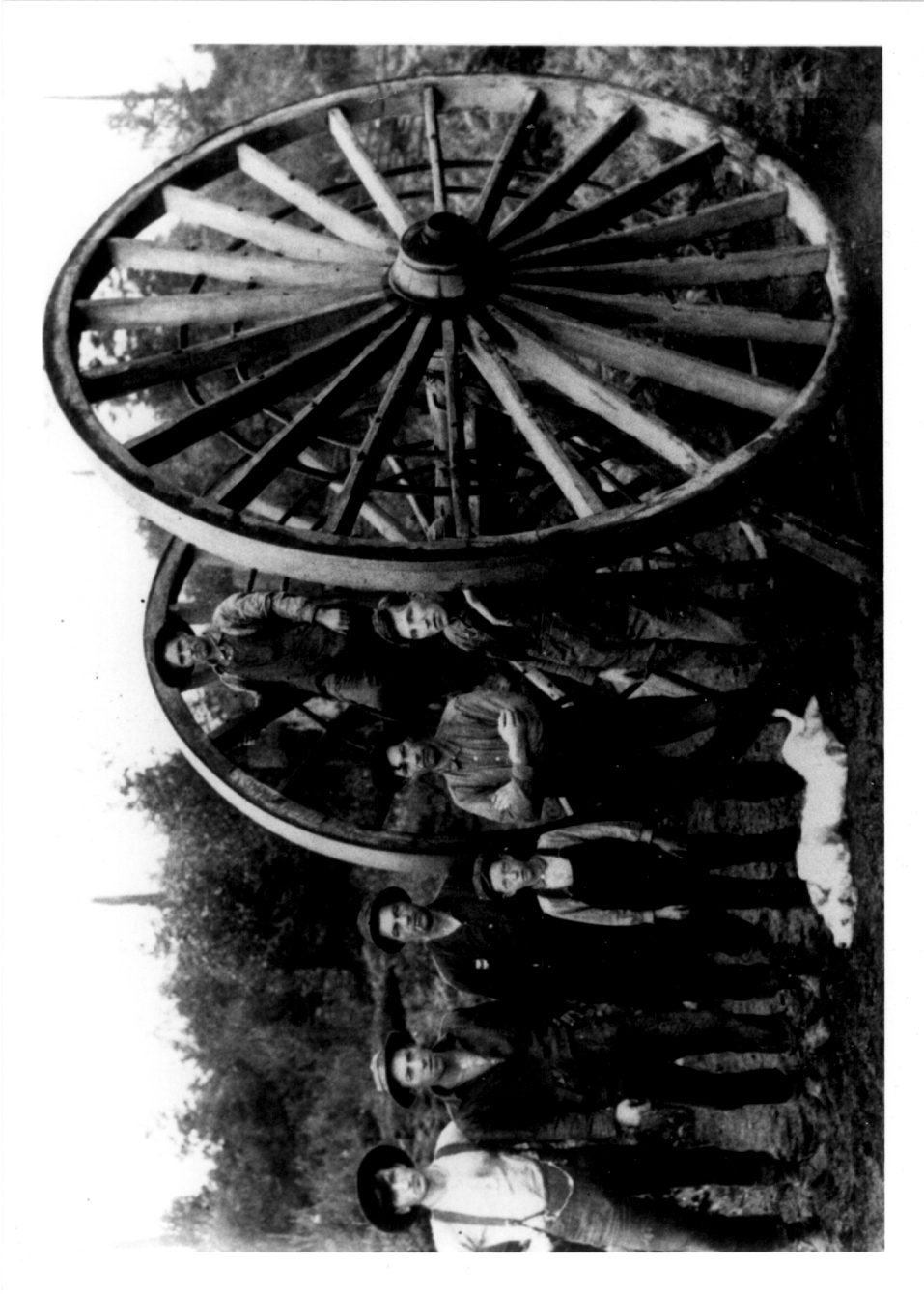

(Photo courtesy Forestry Department, Virginia Polytechnic Institute and State University.)

Figure 3. Big wheels.

introduced only a decade or two ago, e.g., skidding with horses coexisting with helicopter logging. It is not necessary to examine texts and rusting artifacts, or to conduct interviews with aging actors to discern the history of technological development: In industrial forestry and timber harvesting it is still possible to observe the changes as they occur.

Industrial forestry and forest harvesting also present a rich untapped area for studying how technological knowledge is transmitted in a community composed primarily of practitioners who received their training on the job. Although various universities, colleges, and vocational schools throughout the United States now offer formal curricula in industrial forestry, these are a recent development.<sup>16</sup> In the 1940s the majority of woodworkers, from swampers to blacksmiths, still learned their trade on the job as they had a hundred years before. A number of sources have noted the difficulties lumbermen encountered during World War II when the labor pool of experienced woodworkers shrank and employers were forced to rely on unskilled workers. It is in fact during this period in the 1940s, as the industry began to replace informal apprenticeships with standardized training, that attempts to formalize the knowledge content of logging practice for the ordinary worker made their first appearance.<sup>17</sup> If, as some philosophers have asserted, there is a fundamental difference between technological knowledge and scientific knowledge in that former is tacit and cannot be articulated -- knowing how rather than knowing that -- this period of transition in which a group of craft practitioners went from learning by doing to learning through written instructions offers a challenge to anyone interested in the question of whether or not either science or technology

---

<sup>16</sup> In *A Brief History of Forestry in Europe, the United States and Other Countries*, third revised edition (Toronto: University Press, 1913), Bernard Fernow notes that the first school of forestry in the United States was established at Cornell in 1898, but the emphasis in forestry programs for many years was silviculture, not harvest technologies or methodologies. See also Shirley Walter Allen, *An Introduction to American Forestry* (New York: McGraw-Hill Book Company, Inc., 1950), pp. 265-75.

<sup>17</sup> Interviews with William Hutula, July 20, 1988, and John Mihelich, August 3, 1987; Ian Radforth, pp. 161-68; "Marathon Instructs Vets in mechanized logging," *Pulp and Paper Magazine of Canada* March 1946:71-6; "Wanted: loggers -- crucial shortage of lumber caused by manpower pinch," *Newsweek* May 10, 1942:57-8. Texts describing preferred management practices in industrial forestry had emerged as the new science of forestry evolved in the early twentieth century -- Nelson Courtland Brown's *Logging -- Principles and Practices in the United States and Canada* (New York: John Wiley & Sons) was published in 1934, for example, but this first edition of Brown makes no mention of providing instruction for laborers. He notes instead on page 54 that "Forest labor has traditionally been recruited from men familiar with rough and arduous conditions existing in our forest regions."

possesses a unique epistemic status.<sup>18</sup> In addition, although a number of studies have looked at the diffusion of knowledge through an examination of discourse,<sup>19</sup> either in the form of participant-observer studies or content analysis of journal articles, these studies have tended to concentrate on the work of scientists and technologists functioning in a well-established and easily defineable community. In contrast to those studies, which examine what might be termed top-down diffusion in that the knowledge generated is initially produced by a small formally educated elite and then trickles down to the masses, this study deals with knowledge initially generated not in laboratories and think tanks but in blacksmith shops and in the field and only later appropriated by management.

As Richard L. Daft notes,<sup>20</sup> such bottom up diffusion is most likely to occur in a non-bureaucratic environment. This appears to be the case in logging. While the large corporations possessed the desire for mechanization and the funding for research and development,<sup>21</sup> many of the successful innovations occurred first in small shops and isolated locations. Early diffusion was via informal networks, although inventors were not slow in developing formal marketing strategies after prototype machines were successfully tested.<sup>22</sup> Many of these significant innovations were developed not by engineers working in research and development laboratories but rather by amateur inventors and tinkerers, blacksmiths and mechanics, and the loggers themselves. Beginning with the big wheel and the peavey (See Figure 4 on page 13),<sup>23</sup> and continuing to the present day with custom-built skyline systems and

---

<sup>18</sup> For a more extensive discussion of this question, see Agassi, previously cited; Joseph Agassi, "Technology as both art and science," pp. 55-63 in Paul T. Durbin, ed., *Research in Philosophy and Technology Volume 6* (Greenwich, CT: JAI Press Inc., 1983); Carl Mitcham and Robert Mackey, "Technology as a philosophical problem," pp. 1-30 in Mitcham and Mackey; or C. B. Macpherson, "Democratic theory: ontology and technology," pp. 161-70 in Mitcham and Mackey.

<sup>19</sup> See Bruno Latour and Steve Woolgar, *Laboratory Life: The Social Construction of Scientific Facts* (Beverly Hills: Sage Publications, 1979).

<sup>20</sup> Richard L. Daft, *Organization Theory and Design*, second edition (St. Paul, MN: West Publishing Company, 1986), pp. 269-282.

<sup>21</sup> See Radforth, pp. 179-83.

<sup>22</sup> Hubert Moberg, personal interview, August 10, 1988.

<sup>23</sup> Holbrook, p.23.

local adaptations and attachments for loaders and forwarders,<sup>24</sup> many innovations have originated as specific responses to local needs. Although some of these innovations were patented and attempts made to market them, many were not and instead spread informally.<sup>25</sup> In addition, retired loggers report that when these innovations were marketed, the first customers to adopt them often were not the large companies, as one might expect, but rather the small, independent contractors.<sup>26</sup> This pattern of bottom-up diffusion possesses intrinsic interest not only for philosophers and historians interested in knowledge transfer, but also for economists and policy analysts who want to know why some inventions and innovations are widely and rapidly accepted while others apparently equally meritorious are rejected. Although the Forest Service did involve itself in some attempts to improve or develop inwoods equipment,<sup>27</sup> the history of successful<sup>28</sup> innovations in industrial forestry tends to be the history of independent inventors and entrepreneurs who developed their ideas with a minimum of government support and with little interest evidenced by big business until after the innovation had progressed to the point where mass marketing was possible. Thus, it can provide intriguing case studies in the economics of technological change.

Finally, logging presents a challenge to scholars in science and technology studies because it defies easy categorization or explanation utilizing conventional models developed by historians, sociologists, and others to aid in understanding technological change. The regional differences, the varying responses to external and internal stimuli, and the overall amorphous characteristics of

---

<sup>24</sup> A visit to the typical working logging site will reveal the modifications the loggers have made to the standard equipment as they provide the fine touches the manufacturer has not gotten around to building in.

<sup>25</sup> See Holbrook, p. 23; and Donald E. MacKenzie and Elwood R. Maunder, "Logging equipment development in the west," *Journal of Forest History* 16.3(1972):30-33. MacKenzie, a logging superintendent for Anaconda for 34 years, notes that when it came to "originality in the improvement of the machinery, I would say in 75 percent of the cases, came from the logger himself," and states this was true of everything from the chainsaw to the bulldozer, but few people gained financially because "People didn't seem to keep their secrets. They spread the word around."

<sup>26</sup> Mihelich; Hutula; Leonard Lahti, personal interview, August 9, 1987.

<sup>27</sup> See for example, Leslie L. Colvill, "Development and Use of Forest Service Slashbuncher Teeth," *Journal of Forestry* 44( February 1946):89-91.

<sup>28</sup> While the reasons for applying the designation of successful to one innovation and not to another are open to debate, for purposes of this thesis I will employ standard economic criteria: a successful innovation is one which both increases efficiency and is adapted by a wide number of users.



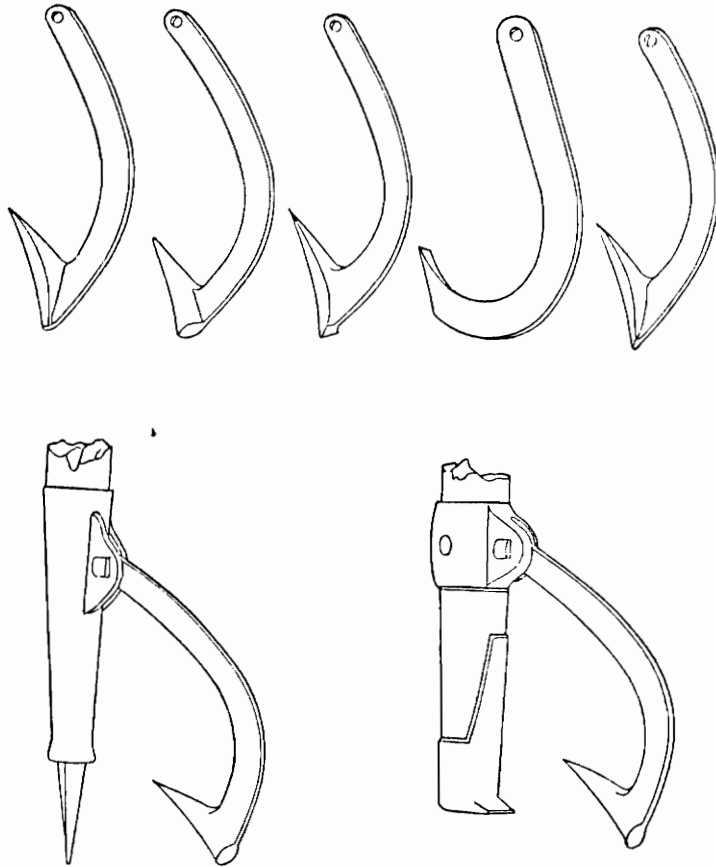

—Peavy on lower left; canthook on lower right. Above are shown various types of hooks—left to right, they are duck bill, round, diamond, chisel, and top loader types.

(From Brown, 1934, p. 79.)

Figure 4. Cant hooks and peaveys.

forest harvesting all combine to make any macro analyses difficult. In addition, the general pattern of commercial forestry, at least in the development of technological devices, has been one that contradicts the image of autonomous and demonized technology posited by Ellul and others.<sup>29</sup> Where Ellul and Borgmann describe a world with increasingly limited choices, a world “radically and tightly restructured,”<sup>30</sup> an examination of industrial forestry practices and timber harvesting suggests a world that has widened its available choices, not reduced them.

Research opportunities thus appear plentiful both in all five phases of the industry, from the initial in-woods felling to the millyard, and in a wide variety of areas in science and technology studies, but this thesis is limited to a case study of the development of equipment used for moving logs, i.e., loaders and skidders. The Cary-Lift, the first extended reach hydraulic fork loader, was selected for this study because changes in millyard equipment paved the way for changes in in-woods equipment: From millyard machines such as the Cary-Lift with its four-wheel drive and hydraulic grapple it was apparently an easy progression to machines such as Timberjack’s four wheel drive skidder and Koehring’s hydraulic ax in the woods. La Tendresse Manufacturing sold its first Cary-Lift in 1949 and became part of a technological revolution in commercial forestry. The Franklin Logger, in contrast to the Cary-Lift, embodied no new or revolutionary ideas but instead was chosen for this study because it serves as an exemplar within normal technological practice in logging. Within a few short years, from 1945 to 1965, logging in North America, emerged from the nineteenth century into the twentieth. The novelty of devices such as the Cary-Lift characterized the beginning of this transitional period, and the routinization of machines such as the Franklin Logger signalled its end.

---

<sup>29</sup> See, for example, Jacques Ellul, *The Technological Society* (New York: Vintage Books, 1964); Albert Borgmann, *Technology and the Character of Contemporary Life* (Chicago: University of Chicago Press, 1987); or Daniel Bell, “Resolving the contradictions of modernity and modernism,” *Society* 27.3(March/April 1990):43-50.

<sup>30</sup> Borgmann, p. 31.

## Chapter Two: A Review of Explanatory Schema

Beginning with Thorstein Veblen's *Theory of Business Enterprise*, first published in 1904, and continuing until the present day, historians, philosophers, sociologists, and economists have been intrigued by the interactions and relationships between technological change and social change. While it is beyond the scope of this thesis to provide a detailed explication of all the models of explanation proposed in recent years, because this thesis is concerned with the processes of invention and innovation and how they relate to the idea of technological determinism, a brief review of some of the more popular schemes utilized in the analysis of technological innovation, including systems, economic, and social constructivist models, might be useful before looking at specific examples of technological change in industrial forestry.<sup>31</sup>

Oddly enough, as Gerhard Rosegger notes, economists became interested in technological change comparatively recently in relation to other disciplines, with Veblen's work serving as a rare exception. Joseph Schumpeter's *Theory of Economic Development*, first published in Austria in 1912 and translated into English in 1934, posited a process of "creative destruction" in which the equilibrium of a stable economic system invited disequilibrium from within through the actions of

---

<sup>31</sup> For a more extensive treatment of theories of technological change cf. Jon Elster, *Explaining Technological Change* (Cambridge: Cambridge University Press, 1985); Govindan Parayil, *Conceptualizing Technological Change*, doctoral dissertation in Science and Technology Studies, Virginia Polytechnic Institute and State University, 1990; Andrew Jamison, "Technology's theorists: conceptions of innovation in relation to science and technology policy," *Technology and Culture* 30.3(1989):505-33.

innovator-entrepreneurs, but received little attention from economists and other scholars thoroughly inculcated with the ideals of classic economic theory and its emphasis on the demand side of the market equation.<sup>32</sup> Although most economists now concede the notion of an unstable system capable of being influenced by both external (demand) and internal (supply) factors is both possible and probable, many economic theories of technological change remain heavily influenced by neoclassical commitments "to the explanation of all phenomena in terms of rational choice within constraints."<sup>33</sup> Economic theories of innovation continue to rely on the concept of the production function, algebraically expressed as  $Q = f(K, L)$ , with Q representing output, K representing physical capital, and L representing labor, and generally pay minimal attention to the social context in which innovations occur.

For example, the concept of appropriate technology is raised only occasionally by economists. Rosegger devotes the concluding four pages of *The Economics of Production and Innovation* to a discussion of appropriate technology, commenting that "Additional disagreement may arise because the debate frequently is carried on strictly in terms of the labor-intensity or capital-intensity of available techniques,"<sup>34</sup> but concludes that, at least in discussing industrial rather than agricultural situations, this may be the most useful way to approach the problem.<sup>35</sup> Nathan Rosenberg and others have taken economists to task for their narrow focus on the tangible factors of production while overlooking or neglecting the less easily quantifiable social factors that may contribute to or hinder the processes of technological change.<sup>36</sup> Invoking memories of Adam Smith, economists and other business professionals continue to equate rational choice with purely economic choice, i.e., maximizing gain while minimizing risk. Indeed, some research and development analysts are convinced, as Brian Twiss notes, that many innovations fail because "a market[ing] orientation is

---

<sup>32</sup> Gerhard Rosegger, *The Economics of Production and Innovation: An Industrial Perspective*, second edition (Oxford: Pergamon Press, 1986), pp. 1-3.

<sup>33</sup> Elster, p. 101.

<sup>34</sup> Rosegger, p. 226.

<sup>35</sup> Rosegger, pp. 266-69.

<sup>36</sup> See Nathan Rosenberg, *Perspectives on Technology* (Cambridge: Cambridge University Press, 1976), pp. 85-105; Jacob Schmookler, *Invention and Economic Growth* (Cambridge, MA: Harvard University Press, 1966), p.3.

still woefully absent in many decisions.<sup>37</sup> Although Twiss's emphasis on identifying needs and potential sales volume constitutes in itself an implicit endorsement of the market-pull impetus for innovation, it also serves as evidence of an increasing awareness that a technically successful innovation may not always result in a commercial success. According to Rosegger, "it has been estimated that some 10,000 new products are developed each year, of which 80 per cent die in infancy; and that, of the remaining 2,000 new products, only about 100 incorporate significant technological advances as well as satisfying an economic demand."<sup>38</sup>

Perhaps the most useful contributions of economists to the study of technological change lie in the unambiguous distinctions they draw between science and technology, between invention and innovation, and between what Schmookler terms invention and subinvention and Rosegger calls primary, or basic, and derivative, or minor innovations.<sup>39</sup> To the economist, science is a public good and technology is private, the invention is the idea and the innovation is a marketable product, and a primary innovation is one which generates "clear discontinuities in the structure and behavior of industries and markets."<sup>40</sup> It should be noted, however, that what may appear to be a seemingly derivative innovation in one market may be a primary innovation generating major changes in another. In short, while economists may "have little understanding of *where* the impulse for it [invention] originates or *why* it is sustained,"<sup>41</sup> economists do appear to share a common vocabulary to utilize in their intradisciplinary discourse.

Sociology of technology, in contrast to economics, seems to lack a clear focus. Although an interest in the effects of technological change can be traced back to the roots of the discipline -- Karl Marx, for example, "believed that labour-saving innovations. . . dominated the development

---

<sup>37</sup> Brian C. Twiss, *Managing Technological Innovation*, second edition (London: Longman, 1982), p. 6.

<sup>38</sup> Rosegger, p. 10; cf. Schmookler, p. 49. Schmookler found that out of a random sample of 1,127 patents issued, only 36.4 percent were in use at the time of his survey. Many inventions, of course, are never patented.

<sup>39</sup> See Schmookler, p.6; Rosegger, p. 15; and Hughes, 1989, p. 58.

<sup>40</sup> Rosegger, p. 15.

<sup>41</sup> Schmookler, p. 5.

of capitalism"<sup>42</sup> -- sociological studies of technology in and of itself were rare until environmental and social concerns during the 1960s and 1970s imbued technology with the requisite aura of a social problem.<sup>43</sup> S.C. Gilfillan, writing in 1935 that "The social causes of invention all come from the world outside the inventor and act through him,"<sup>44</sup> would languish in obscurity for over forty years. Stephen Cutcliffe argues that it took the "collapse in the late 1960s of a twenty year-long, direct translation of science and technology into economic prosperity for the American working class"<sup>45</sup> to stimulate an interest in an externalist, sociologically-oriented approach to science and technology studies. When sociologists became involved in technology studies, they first gravitated to areas where open conflicts or dramatic problems existed, e.g., debates over worker exposure to toxic chemicals or the controversy surrounding the nuclear power industry, and indeed many social scientists continue to focus their attention on these areas.<sup>46</sup> Recently, however, some sociologists have turned their attention to more mundane and less obviously problematic topics, such as "The social construction of Bakelite,"<sup>47</sup> Still, despite disclaimers to the contrary, many sociologists appear to enjoy a disdainful attitude toward technology and frequently will describe studies of applied technology or the development of technological devices and instruments not as sociology of technology but rather as science studies.<sup>48</sup> Further, in addition to being prone to conflating arcane

---

<sup>42</sup> Elster, p. 177; cf. Karl Marx, "Toward a Critique of Hegel's *Philosophy of Right: Introduction*," pp. 63-74 in David McLellan, editor, *Karl Marx: Selected Writings* (Oxford: Oxford University Press, 1988), p. 73; and Karl Marx, "Capital," pp. 415-507 in McLellan, p. 488.

<sup>43</sup> See Gary L. Downey, Arthur Donovan, and Timothy J. Elliott, "The invisible engineer: how engineering ceased to be a problem in science and technology studies," ms. 1989, p. 4; Peter I. Rose, Penina M. Glazer, and Myron Glazer, *Sociology* (Englewood Cliffs, NJ: Prentice-Hall, Inc., 1984), p. 18.

<sup>44</sup> S. C. Gilfillan, *The Sociology of Invention* (Cambridge, MA: 1970) (first published in 1935), p. 44.

<sup>45</sup> Stephen Cutcliffe, "The emergence of STS as an academic field," *Research in Philosophy & Technology*, Volume 9 (1989):287-301, p. 287.

<sup>46</sup> See for example Dorothy Nelkin and Michael S. Brown, *Workers at Risk: Voices from the Workplace* (Chicago: University of Chicago Press, 1984), or Gary L. Downey, "Ideology and the Clamshell identity: Organizational dilemmas in the anti-nuclear power movement," *Social Problems* 33(1986):357-73.

<sup>47</sup> Wiebe E. Bijker, "The social construction of Bakelite: toward a theory of invention," pp. 159-187 in Wiebe E. Bijker, Thomas P. Hughes, and Trevor J. Pinch, editors, *The Social Construction of Technological Systems: New Directions in the Sociology and History of Technology* (Cambridge, MA: The MIT Press, 1989).

<sup>48</sup> See for example Gerald E. Markle and Stanley S. Robin, "Biotechnology and the social construction of molecular biology," pp. 111-21 in Daryl E. Chubin and Ellen W. Chu, editors, *Science Off the Pedestal* (Belmont, CA: Wadsworth Publishing Company, 1989).

or complex with significant -- a quick perusal of professional journals reveals an inordinate fascination with computers and artificial intelligence -- sociologists of science often utilize a confusing and contradictory lexicon of professional jargon while conducting narrowly focused ethnographically-oriented internalist studies. At its worst, while ostensibly discussing the "social construction" of a phenomenon, albeit a physical artifact or a theoretical fact, this type of sociology looks only at the social context within a particular laboratory or discipline and fails to consider how factors outside the laboratory may influence events within it, and, even at its best, as in the work of scholars such as Bijker or Michel Callon,<sup>49</sup> Susan Cozzens suggests it runs the risk of being unbalanced in its dedication to actor-level microsociological approaches.<sup>50</sup> Whether this general lack of interest in technology studies can be attributed to the lingering influence of the "bad old days"<sup>51</sup> when science engaged in discovery and technology merely applied those discoveries, or to what Andre Gorz has castigated as the product of the bourgeois false-consciousness of a society that "calls 'scientific' only those notions and skills that are transmitted through a formal process of schooling and carry the sanction of a diploma conferred by an institution,"<sup>52</sup> is debatable. What is not is the fact that, as Pinch and Bijker note, "the sociology of technology is still underdeveloped in comparison with the sociology of scientific knowledge."<sup>53</sup> If social constructivist studies arguing that the developmental processes of technological artifacts are the result of decisions about variation and selection made by actors, e.g., consumers and designers, within the social network the artifacts are a part of can successfully make the transition from micro levels of analysis to macro levels, i.e., from looking at one network to looking at how many different networks within a society interact,

---

<sup>49</sup> See Bijker, previously cited, or Michel Callon, "The state and technical innovation: a case study of the electric vehicle in France," *Research Policy* 9(1980)358-76. Callon describes actor-networks and does give equal weight to the influence of both animate and inanimate actors within those networks.

<sup>50</sup> Susan Cozzens, "Book review: *The Social Construction of Technological Systems: New Directions in the Sociology and History of Technology*," *Technology and Culture* 30.3(1989):705-07.

<sup>51</sup> Trevor Pinch and Wiebe E. Bijke, "The social construction of facts and artifacts: or how the sociology of science and the sociology of technology might benefit each other," pp. 17-50 in Wiebe E. Bijker, Thomas P. Hughes, and Trevor Pinch, editors, *The Social Construction of Technological Systems: New Directions in the Sociology and History of Technology* (Cambridge, MA: The MIT Press, 1989), p. 20.

<sup>52</sup> Andre Gorz, "On the class character of science and scientists," pp. 59-71 in Hilary Rose and Steven Rose, editors, *The Political Economy of Science* (London: MacMillan, 1976), p. 61.

<sup>53</sup> Pinch and Bijker, p. 47.

sociology of technology could fulfill its promise of developing an enriched understanding of technological processes and society.

History of technology possesses the most ancient lineage of any discipline involved in technology studies, however, like economics and sociology, until recently the history of technology was open to criticism for being excessively internalist. Internalist history focuses its attention on the artifact -- the sewing machine, the cotton gin, the logging tractor -- to the exclusion of the relation of that artifact to its social context.<sup>54</sup> Such internalist histories also tended to be uncritical success stories and implicitly tautologically deterministic, i.e., a particular technological artifact had to succeed because it was the best idea and it was the best idea because it succeeded. The shift in focus away from internalist studies in the history of technology has been attributed in part to the founding in 1958 of the Society for the History of Technology (SHOT),<sup>55</sup> a professional organization which encourages "the study of technology and its relations with society and culture."<sup>56</sup> As SHOT has matured, a shared discourse has emerged regarding invention and innovation -- like economists, for example, historians of technology define invention as the mental activity or initial ideas while innovation is viewed as the entrepreneurial efforts put forth to introduce the product or process to the "functioning technological world."<sup>57</sup> Beginning with Lynn White jr.'s *Medieval Technology and Social Change* and continuing to the present day, historians have been publishing work which is increasingly contextual or externalist in orientation. Scholars are also actively attempting to formulate macro-level theories of explanation for technological change. In *The Origins of the Turbo-jet Revolution* Edward Constant attempted to apply Thomas Kuhn's notion of a paradigm shift to breakthrough innovations by developing the concept of a presumptive anomaly.<sup>58</sup> Constant's work falls within what Staudenmeier describes as the concept of a single technical

---

<sup>54</sup> See John M. Staudenmeier, *Technology's Storytellers: Reweaving the Human Fabric* (Cambridge, MA: The MIT Press, 1989), p. 9.

<sup>55</sup> See Staudenmeier, pp. 1-34; Cutcliffe, pp. 291-2.

<sup>56</sup> From the statement of purpose in *Technology and Culture*, the official journal of the Society.

<sup>57</sup> Staudenmeier, p. 39.

<sup>58</sup> See Edward W. Constant II, *The Origins of the Turbojet Revolution* (Baltimore, MD: The Johns Hopkins Press, 1980) pp. 15- 20, for a complete explanation of this idea.



tradition, i.e., "a single tradition is understood to extend through a number of time periods during which the technology is refined by an increasingly focused body of expertise."<sup>59</sup> Constant's concept of a normal technology is quite similar to the concept of a technological frame that Bijker employs in explaining the social construction of technology; both concepts imply a community of practitioners within a single discipline or actor-network operating through a shared set of traditions and beliefs.<sup>60</sup>

The other major thematic approach to emerge in the history of technology is that of the systemic analysis. A systems analysis assumes that technologies both exist within and function as systems, and that everything within a system influences everything else within that system. Thomas P. Hughes employed systems analysis in his study of the development of the electric utility industry, *Networks of Power*, and has argued that a technological system is both "socially constructed and society shaping."<sup>61</sup>

The systems model emphasizes the interdependency of various components such as physical artifacts, social and economic organizations, governmental regulations, and natural resources as they interact to achieve a common goal. Altering, removing, or adding components in a system can affect all the other components, and the characteristics of the individual components not only influence the characteristics of other components but the overall style and characteristics of the system as a whole. The notion of a technological system contains deterministic elements because it recognizes that, although individual human beings may decide how to perform certain tasks or which problems to solve first, the location of other components such as deposits of ore or the direction of a river's flow may determine where those tasks will be performed or what the problems are. The acknowledgement that the environment a system exists within, both cultural and geographic, influences the direction a technology may take reflects the fact a technological system is both socially constructed and a constructor of society. Of the models of explanation proposed to date, whether by economists, sociologists, historians, or philosophers, the last mentioned, the

---

<sup>59</sup> Staudenmeier, p. 39.

<sup>60</sup> See Constant, pp. 8-15; Bijker, p. 168.

<sup>61</sup> Hughes, 1989, p. 51.

systems model as posited by Hughes, while not wholly problem-free, appears to offer the widest utility for analyzing technological change. The standard economic models fail to account for noneconomic factors, such as personal prejudices or local customs and beliefs, while the social constructivist models with their emphasis on actor networks and negotiating strategies neglect the influence standard factors of production, i.e., access to scarce resources, may have on innovation. Models of explanation based on Kuhnian paradigmatic theories, e.g., Bijker's technological frame and Constant's presumptive anomaly,<sup>62</sup> may work on a micro-level, i.e., within one particular network or frame, but do not adequately account for interactions between networks, nor do they allow for the simultaneous co-existence of incommensurable technologies and frames.<sup>63</sup>

---

<sup>62</sup> See Bijker, Constant.

<sup>63</sup> In *The Structure of Scientific Revolutions* (Chicago: University of Chicago Press, 1970) Thomas Kuhn's theory of scientific revolutions posited that a scientist could work in only one paradigm, i.e., you could either believe in a heliocentric universe or a geocentric universe, but not both, because scientific theory is based on belief in truth-values. Technology, on the other hand, allows for the mutual existence of different tools, and using an elevator one day does not entail never climbing stairs again.

## Chapter Three: A Brief History of Logging

Logging in the 1940s was an industry in transition. Beginning in the Northeast in the early years of the nineteenth century and continuing across the country to the Pacific Northwest, loggers participated in what Holbrook and others have characterized as the "Big Clearing" or the "Big Cut."<sup>64</sup> Despite the concerns voiced by a few professional foresters, the public demand for lumber and other wood products in the late nineteenth century continued to increase and encouraged the industry to behave as though the supplies of timber were inexhaustible. Indeed, timber resources of the North American continent appeared so vast that early efforts to impose timber cutting regulations in the colonies similar to those regulations enforced in Europe had been rapidly abandoned. Although a few states passed legislation meant to regulate logging, it was not until the early 1890s that President Cleveland proclaimed seventeen federal forest reserves with a total of 17,500,000 acres, and it took until 1897 to pass legislation providing for the administration of the reserves.<sup>65</sup> Some historians and environmentalists have painted a picture of the nineteenth century lumbermen as wallowing in excess, practicing a style of logging which left an eroding wasteland of

---

<sup>64</sup> Holbrook, p. 152.

<sup>65</sup> See Fernow, pp. 466-67; Holbrook, pp.31-32. According to Fernow, Cleveland's support of the federal forest reserve acts so angered commercial logging interests that they urged his impeachment. Fernow, pp.480-85. For a fuller account of the creation of the United States Forest Service see Gifford Pinchot, *Breaking New Ground* (New York: Harcourt, Brace and Company, 1947), pp. 79-263; United States Department of Agriculture, *After A Hundred Years: The Yearbook of Agriculture, 1962* (Washington, D.C.: The United States Government Printing Office, 1962), pp. 152-57, and pp. 238-74.

stumps and rotting slash in its wake, with "valuable black walnut squandered for fence rails and firewood, and millions of board feet of hemlock rotting because the bark had been stripped for tanning."<sup>66</sup> This is a rather distorted and melodramatic picture as many lumber companies utilized almost every part of the trees harvested,<sup>67</sup> but it is true rivers became choked with silt, boom towns turned to ghost towns, and loggers moved on.<sup>68</sup> Rather than operating on a sustained yield basis as agriculture and forestry now do, nineteenth century logging was an extractive industry akin to mining. It exploited the existing natural resource to its fullest extent. Loggers clear cut and harvested the most valuable species of wood, and then, when the white pine or the hemlock or the hardwood were gone, the industry packed up and headed west. According to Holbrook, Vail, and others, this practice of high-grading, of taking only the best and leaving the rest, had been customary for as long as a logging industry had existed in the United States.<sup>69</sup> It had been doing this for over one hundred years and the equipment it utilized had been developed to assist in clearcutting large tracts of timber, not to selectively harvest small stands or to thin plantations.<sup>70</sup>

Railroad logging, which reportedly first emerged in Michigan in the second half of the nineteenth century, was both capital intensive and dependent upon a large harvest to be

---

<sup>66</sup> Dale White, *Gifford Pinchot: The Man Who Saved the Forests* (New York: Julian Messner, Inc., 1957), p. 54.

<sup>67</sup> See, for example, Thomas T. Taber III, *Tanbark, Alcohol, and Lumber* (Williamsport, PA: Lycoming Press, 1974).

<sup>68</sup> See Alfred Van Tassel, *Mechanization in the Lumber Industry: A Study of Technology in Relation to Resources and Employment Opportunity* (Philadelphia, PA: Work Projects Administration, 1940), pp. 122-23; Holbrook, pp. 152-60; and David Vail, "How to tell the forest from the trees," *Technology in Society* 11(1989):317-76.

<sup>69</sup> See Nelligan; Van Tassel, pp.6-18; Thomas T. Taber III, *Ghost Lumber Towns of Central Pennsylvania: Laquin, Masters, Ricketts, Grays Run* (Williamsport, PA: Lycoming Printing Co., 1970). Taber's work is of particular interest in that it describes industrialized logging operations in Pennsylvania in which the primary material being harvested was hemlock bark for tanneries while other woods products industries, e.g., sawmills and kindling factories, emerged to utilize the waste product, the logs. This reversed the more well-known practices of the lumber and pulpwood industries, in which the logs were the primary material and the bark was a waste product.

<sup>70</sup> A thorough description of past ecologically unsound management practices in industrial forestry is beyond the scope of this thesis. I would simply note that the late nineteenth century was a period of rapid growth in the United States and many logging practices were a response to high demand for lumber and other wood products. In addition, despite the rhetoric Fernow and Pinchot employed, in many areas very little of the tree was wasted, and where waste did occur, it was hardly unique to logging in the nineteenth and early twentieth century -- mining, agriculture, and manufacturing of all types have all engaged in short-sighted, potentially harmful, and highly wasteful practices -- and the consequences have been well-documented elsewhere.

profitable.<sup>71</sup> According to Maybee, the Lake George and Muskegon River Railroad, which began operations in October 1876, "was the first successful logging railroad in the United States."<sup>72</sup> By the 1880s locomotive manufacturers were targeting the potentially huge and lucrative market lumbermen represented with advertisements that argued:

A logging railroad is the cheapest and best plan for putting in logs, both on a large scale or on quite a small scale. With good locomotive and cars the expense of hauling does not exceed 25 to 40 cents per thousand feet, and at the end of years of hard work the rolling stock, if of good quality and treated with decent care, will be practically as good as new. Steam logging on iron rails is independent of weather or season; the output can be doubled by working nights; more logs can be got off the same land, as the poorer grades can be hauled with profit; windfalls and burnt timber can be marketed before damaged by worms and rot; timber land distant from streams and [public carrier] railroads are made as valuable as any others.<sup>73</sup>

Some economists would argue this can be seen as a technology developing in response to the market pull of an industry's specific needs,<sup>74</sup> but although railroad logging did free timbermen from the geographical limitations of river drives, it was not an inevitable development. Loggers could be quite ingenious in using extremely small streams of water to transport timber during the spring runoff where no railroads yet existed, and indeed succeeded in clearcutting vast reaches of Maine, Pennsylvania, Michigan, Wisconsin, Minnesota and other states before any rails were ever laid in those regions. In *Holy Old Mackinaw* Holbrook describes the rerouting of the waters of the Penobscot and Kennebeck rivers in Maine by loggers in the 1850s.<sup>75</sup> Twenty years later Wisconsin loggers also were confronted with an occasional inadequate water supply, and Nelligan recounts the methods he employed while supervising a river drive on a small stream, a branch of the Beaver River in northern Wisconsin, in 1879:

Across this small stream we threw a dam and, when it was completed, dropped the sluice gates and kept them down all winter, from November to April. We had hoped to get a good head of water back of the dam but were disappointed, the water rising only four feet during those five long winter months. My crew made a cut of three million board feet, all of which was landed on the lake.

When spring came we found that there was not sufficient water behind the first dam to carry the logs down to the second one. So we built two more dams in between and then cut a ditch between Nelligan Lake and another small lake in close proximity, draining the water from the latter in the former. This gave us enough water to start the drive, which went along fairly well for some distance

---

<sup>71</sup> Van Tassel, p. 9., Maybee, 37-43.

<sup>72</sup> Maybee, p. 39.

<sup>73</sup> Maybee, p. 38.

<sup>74</sup> See Rosenberg, p. 267; Schmookler, p. 213.

<sup>75</sup> Holbrook, pp. 35-38.

downstream and then hung up high and dry for lack of water. This necessitated the building of another dam.<sup>76</sup>

Where no natural bodies of water existed loggers would construct flumes and canals, or, when water was particularly scarce, as in the mountains of Wyoming and Montana, or the wood unsuitable for floating, e.g., the redwoods of California, greased skidways.<sup>77</sup>

More significant than the removal of geographical constraints may have been the elimination of temporal boundaries. Railroads made year round logging possible as well as removing species limitations in the Lake States and elsewhere, i.e., many varieties of wood were not sufficiently buoyant for river drives to be used to transport them, and prior to railroad logging were viewed as unusable by lumbermen. Mary Roddis Connor reports that "Until the railroad opened new markets, Wisconsin forests had seen logging only the great pines. Only pines and cedar could float to the mills or market. Intermixed hardwoods had been considered worthless; the majestic tracts of oaks or maple often were burned off as useless or in the name of progress for farm settlements."<sup>78</sup>

Although the locomotive manufacturers optimistically claimed that their equipment was suitable even "on quite a small scale,"<sup>79</sup> this simply was not true, and equipment developed for use with railroad logging, such as the Barnhart and McGiffert loaders (See Figure 5 on page 27), was also large, steampowered, and capital intensive.

The growth of large lumber companies operating multiple camps and employing hundreds of men paralleled the growth of railroad logging. As Maybee notes, "with the advent of the little logging railroads in the late seventies. . .camps became multiple instead of single, all under one management. . . [L]ogging operations emerged into a highly specialized and well developed business

---

<sup>76</sup> Nelligan, pp.77-78. See also LeRoy Barnett, "Taming the Tahquamenon," *Michigan History* 74.1(1990):21-3, for a description of the rerouting of the Tahquamenon River in Upper Michigan.

<sup>77</sup> See Brown, 1934, p. 212.

<sup>78</sup> Mary Roddis Connor, *A Century with Connor Lumber: Connor Forest Industries, 1872-1972* (Stevens Point, WI: Worzalla Publishing Co., 1972), pp. 9-10. Almost all green wood will not float, and even when dry many hardwoods are too dense for water transport.

<sup>79</sup> Maybee, p. 38.



From Benjamin F. G. Kline jr., *Dinkies, Dams, and Sawdust: The Logging Railroads of West Central Pennsylvania* (Williamsport, PA: Locomotive Press, 1975), p. 1268.)

Figure 5. A Barnhart loader c.1900.

enterprise."<sup>80</sup> It is not surprising that raker teeth on crosscut saws, big wheels, donkey engines, and cable yarding systems were also all developed during this same time period in the late 1870s and would not change significantly for fifty years. The industry had developed a system for efficiently processing large tracts of timber, and, as Hughes has noted, once a technological system is in place, it can be difficult to implement changes within it.<sup>81</sup>

The skidding machine patented by Horace Butters in Michigan in 1886 never really caught on in the Lake States, but similar high lead cable systems (See Figure 6 on page 29) became popular both in the Louisiana bayous and the Pacific Northwest.<sup>82</sup> The big wheel, the forerunner of the modern logging arch,<sup>83</sup> and high lead cable skidding both were based on the desire to make logs easier to move by lifting the leading ends off the ground and thus eliminating the need to wait to log in the winter when snow and ice could be used for skidways. All five innovations -- raker teeth, cable yarders, railroads, big wheels (See Figure 3 on page 9), and donkey engines -- corresponded with the boom years of the lumber industry. The raker tooth (See Figure 1 on page 7) cleared sawdust from the cut and reduced dramatically sawing time per tree, and donkey engines replacing horses and oxen provided skidding and loading power that never became fatigued.<sup>84</sup> The first recorded use of a donkey engine occurred when John Dolbeer of the Dolbeer and Carson Lumber Company of Eureka, California, began snaking logs out of the redwoods along Salmon Creek in August 1881. According to Holbrook, "Dolbeer's invention, in a rather brief time, turned the lumberjack into a comparatively sober and well-ordered mechanic."<sup>85</sup> This is a slight exaggeration,

---

<sup>80</sup> See *The Visible Hand: The Managerial Revolution in American Business* (Cambridge, MA: The Belknap Press, 1977) in which Alfred D. Chandler jr. argues on p. 6 that "modern multi-unit business enterprise replaced small traditional enterprise when administrative coordination permitted greater productivity, lower costs, and higher profits than coordination by market mechanisms."

<sup>81</sup> Hughes, 1989, pp. 76-80.

<sup>82</sup> Holbrook, p. 102.

<sup>83</sup> Brown, 1934, describes the horse-drawn big wheel as constituting "a distinct phase [in the evolution of skidding] preceding the tractor on gentle topography in not too big timber (p. 149)."

<sup>84</sup> Van Tassel, Holbrook (1954), Connor

<sup>85</sup> Stewart H. Holbrook, "So Long Jigger Jones," *The Saturday Evening Post* 212(July 8, 1937):22-3 + , p. 31.



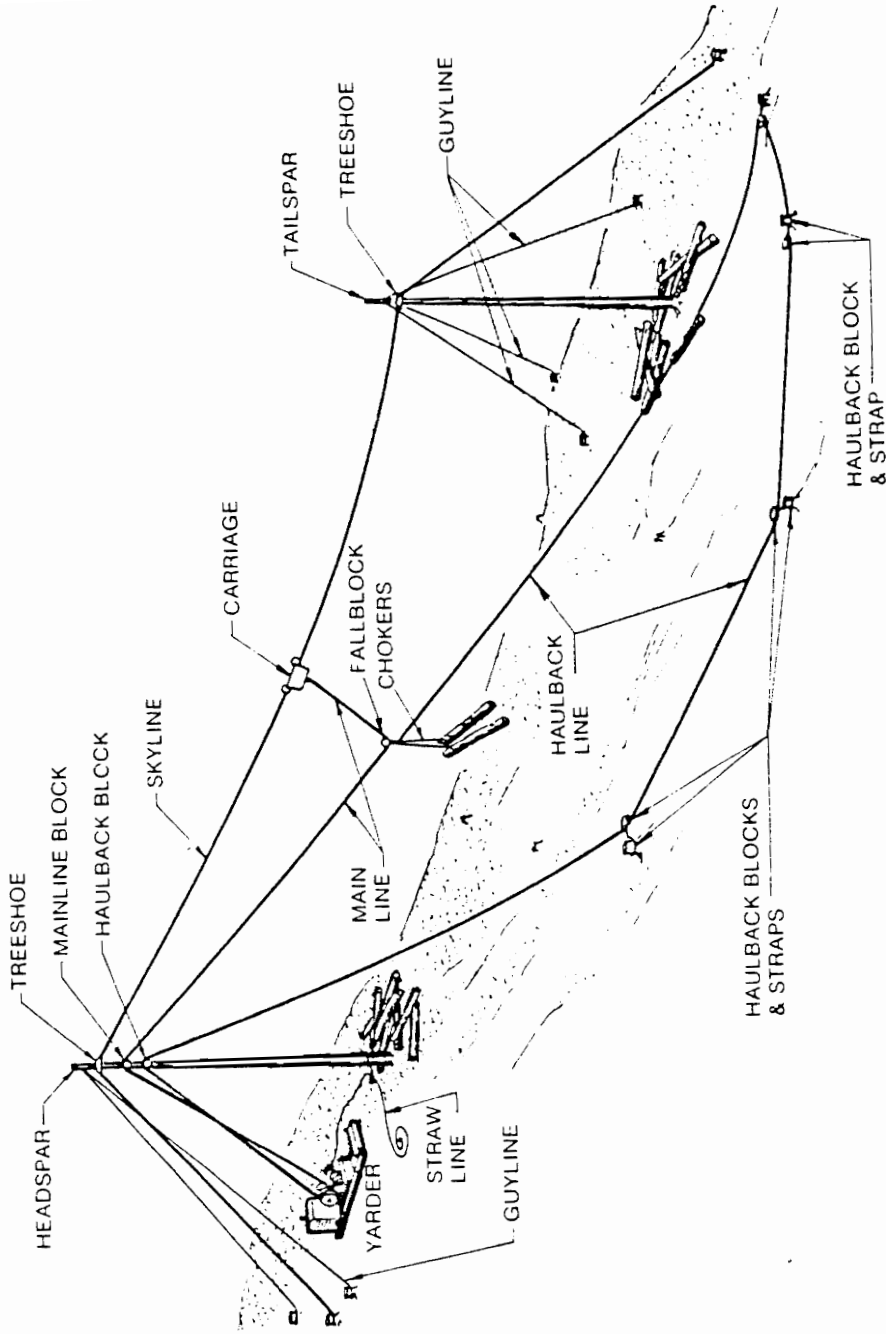

(From United States Department of Agriculture, *Handbook for Eastern Timber Harvesting*, p. 95.)

Figure 5. A North Bend cable yarding system.

but it was true railroad logging and its ancillary equipment required large harvests to be profitable, and large harvests in turn required a dependable labor force.<sup>86</sup>

Still, despite having developed the mechanical means to efficiently harvest large tracts of timber, the lumber companies only gradually turned their attention to the labor question. Steam power first came to the woods in the 1870s and 1880s, but it was not until after the turn of the century that the labor question began to be seriously addressed. When steam power was first introduced, with the exception of the Southern states, the typical lumberjack was a young unmarried male and not infrequently a recent immigrant.<sup>87</sup> Living conditions were primitive, and the following description by Holbrook is not atypical:

. . .the lumberjacks slept sixteen and twenty-four to the bunk, and they needed to have worked hard to sleep at all on stiff-needed boughs of fir, or on hay that was softer, but itchy. The camps of 1908 were of logs chinked with moss; the floor, mere poles, down between which all refuse was chucked until the place was level. One hundred men lived and slept in one room that had one small window and was draped nightly and Sundays with the steaming clothes of men who had worked hard for ten hours.<sup>88</sup>

The arduous work combined with miserable living conditions were indeed enough to “weed out the weaklings in one season,”<sup>89</sup> and, even during a time when hundreds of thousands of immigrants were streaming to America seeking work, lumbermen experienced difficulties in finding and keeping workers. Debt peonage, i.e., the infamous company store system, flourished and pay vouchers would be withheld until the end of the season. If the men were paid more often, it was not uncommon for loggers to take their money into the nearest town and not return.<sup>90</sup> Conlin reports

---

<sup>86</sup> See Maybee, pp. 19-21.

<sup>87</sup> In the South, blacks and married men comprised a large portion of the primary workforce and lumbering took place in less geographically isolated areas. Camps were less common than in the northern and western states and Canada. See Conlin, p. 183; Nollie W. Hickman, *Mississippi Harvest* (Montgomery, AL: Paragon Press, 1962). Hickman reports that lumbermen attempted to bring in Scandinavian woods workers but “perhaps the hot, humid climate caused the people of the northern climate to avoid the South” (p. 246) as most of these workers left quickly. See also Russell F. Thienpont, *Tract Size and Timber Harvesting System Relationships in the Southeast*, Master’s thesis, Virginia Polytechnic Institute and State University, 1976.

<sup>88</sup> Holbrook, 1937, p. 30; cf. Maybee, pp. 19-25.

<sup>89</sup> Holbrook, 1937, p. 21.

<sup>90</sup> See Conlin, Maybee, pp. 19-21. During an August 1988 interview William Hutula reported that during the 1930s even when the Great Depression was at its worst labor turnover was high, and Hutula’s camp was down right luxurious compared to the conditions Holbrook describes.

that the first attempts to improve camp conditions began with the food, and Radforth and Rajala agree that it was not until radical labor organizers began demanding more sanitary living conditions that lumber and pulpwood companies started to provide decent housing. From primitive temporary clusters of shacks in the woods logging camps evolved into stable company towns such as Shelton, Washington, and Pequaming, Michigan, all set up to efficiently process, from the stump right through the mill, large amounts of timber (See Figure 7 on page 32). Unfortunately, by the 1930s those large harvests were gone, and in a few short years the company towns, at least in the Midwest, would also vanish. What Bernard Fernow and others had predicted in earlier years, the denuding of American woodlands, was becoming a reality. While it had not occurred as quickly as predicted by Fernow in 1907 when he decried the "rapid decimation of our forest supplies,"<sup>91</sup> the wasteful practices of large scale industrial forestry had finally caught up with the industry. Except for the Pacific Northwest region, the thick stands of old growth timber no longer existed. And, along with the unlimited supply vanishing, so had the demand. Other building materials, e.g., brick and concrete, had supplanted pine and spruce in new construction as the wooden buildings of the nineteenth century were replaced by the brownstones and skyscrapers of the twentieth in urban areas. As Van Tassel notes, the demand for lumber had peaked in 1910 and steadily declined thereafter.<sup>92</sup> This decline in the demand for saw timber was counterbalanced by a steadily increasing demand for pulpwood, but the species utilized for pulpwood as well as the size of the trees harvested often differed from those utilized for saw timber. Railroad logging to clearcut thousands of acres of virgin white pine for lumber made economic sense; railroad logging to harvest much smaller stands of second growth aspen did not.

At the same time, the lifestyle of logging and lumberjacks began to pass into American folklore. In the foreword to the revised edition of *A White Pine Empire* Joseph Shafer notes that when John Nelligan was actively pursuing his career as a lumberman between 1870 and 1910, there were no Paul Bunyan legends: "Apparently Nelligan, despite his diversified experience in the woods of New Brunswick, Maine, Pennsylvania, Michigan, and Wisconsin, had hardly so much as heard of the

---

<sup>91</sup> Fernow, p. 473.

<sup>92</sup> Van Tassel, p. 1.

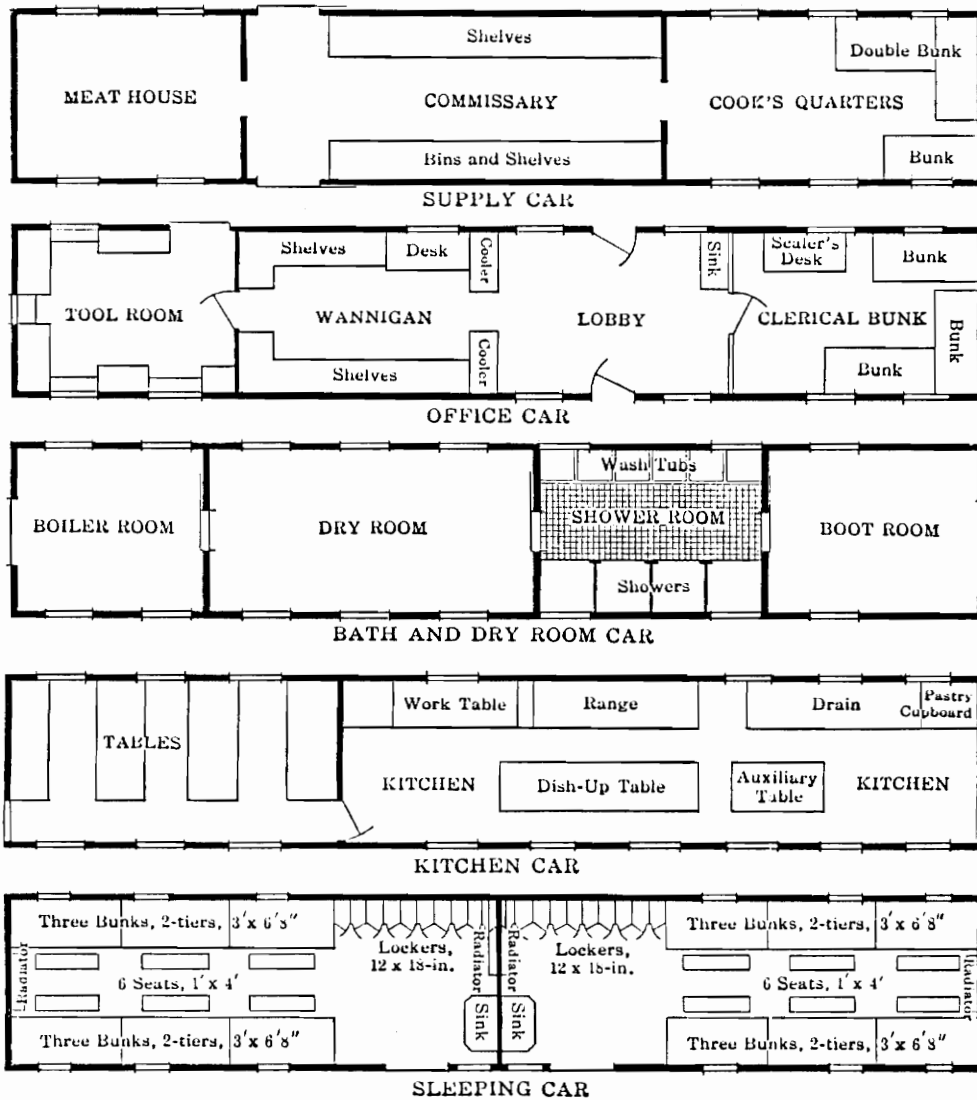

FIG. 15.—Floor plans of five cars used in one of the largest and better equipped car camps in the Northwest. Excellent facilities, such as shower rooms, drying rooms, opportunities for recreation and reading, are provided in many of these camps. In matters of sanitation great advances have been made during recent years, especially in the Northwest. Taken from 4-L Bulletin, Portland, Oregon.

(From Brown, 1934, p. 62.)

Figure 7. A suggested logging camp layout.

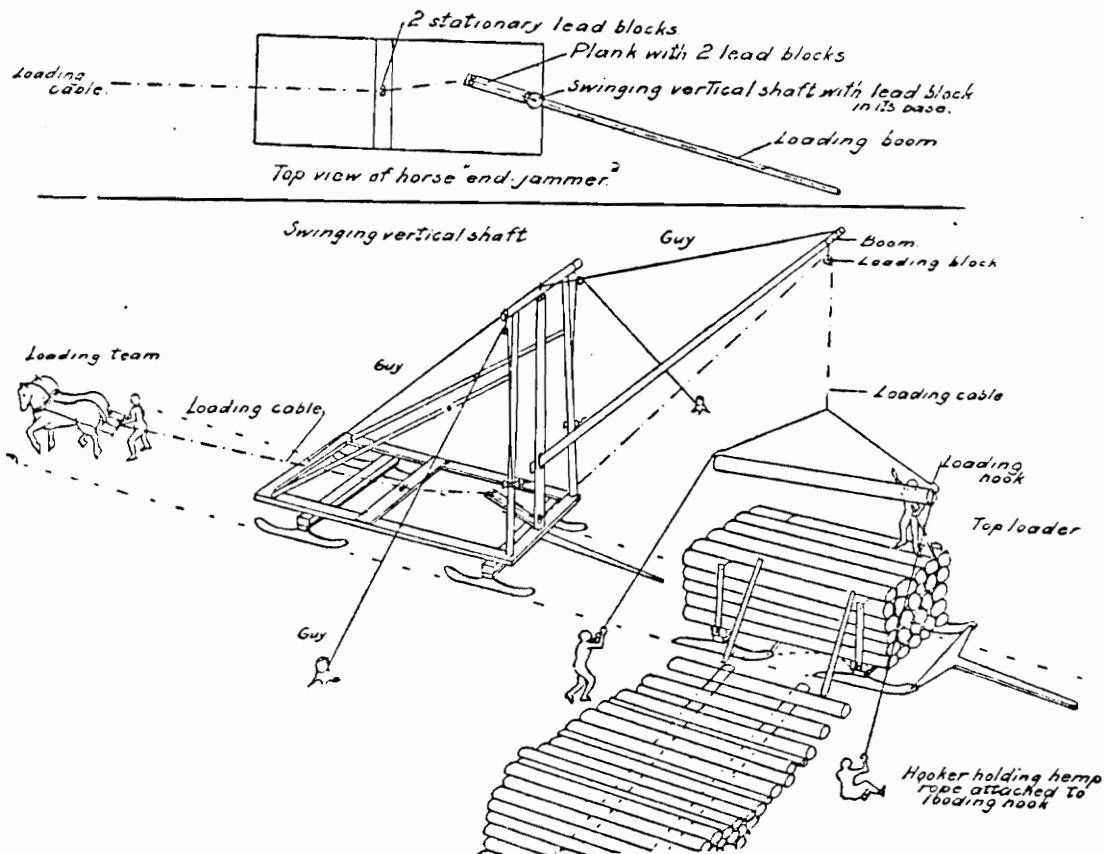

Fig. 47. End-jammer operated by team (Minnesota).

(From A. Koroleff, *Pulpwood Hauling with Horse and Sleigh* (Pulp and Paper Research Institute of Canada, 1947), p. 114.)

Figure 8. Horse-powered cable jammer.

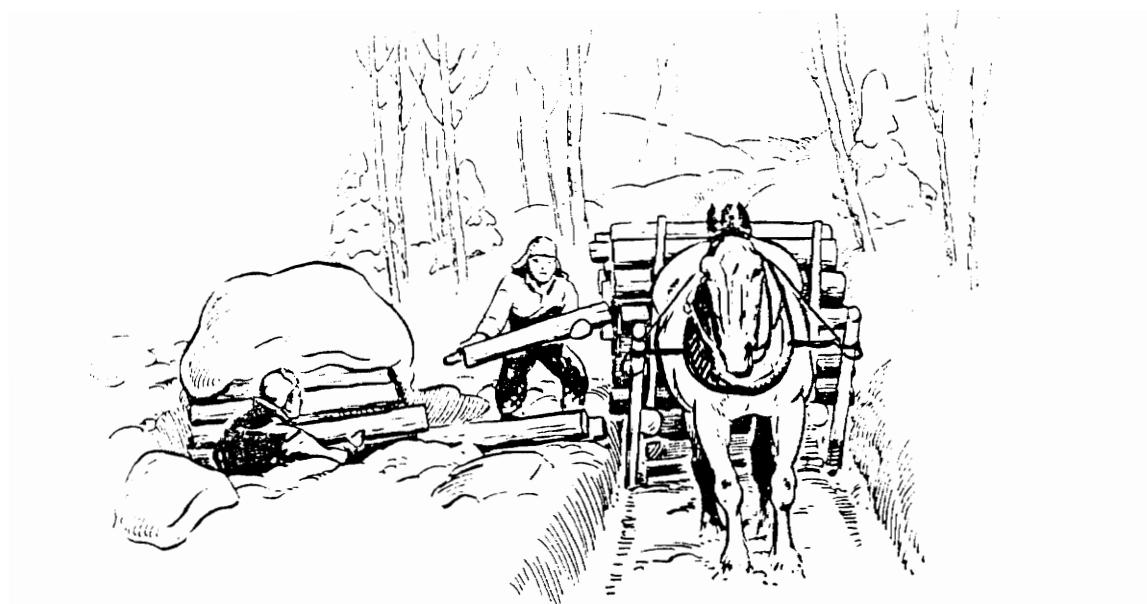

Fig. 42. Two men loading 4' wood in deep snow, when pile is too far from the road.

(From Koroleff, 1947, p. 108.)

Figure 9. Hand loading pulpwood in Canada.

---

redoubtable Paul or his blue ox, Babe. Why this is we can only surmise."<sup>93</sup> When Shafer wrote those words in 1969, Paul Bunyan had become an integral part of American folklore; when Nelligan wrote his memoirs in 1929 the legend was still being created. The first Paul Bunyan stories apparently were published by James MacGillivray, a Detroit newspaperman, in 1910 and slowly gained a national audience. By 1925 both Esther Shephard and James Stevens had published collections of folk tales with identical titles, i.e., *Paul Bunyan*, and by the mid-1930s the American public was thoroughly familiar with Paul's prowess in the woods, his creation of both the Great Lakes and Puget Sound, his bookkeeper, Johnny Inkslinger, and his blue ox, Babe, who sported horns forty ax handles from tip to tip. These tales, however, were not collected by ethnographers and folklorists studying American lumberjacks but were instead apparently the product of logging company publicists and other creative writers. The daily life of the lumberjack, filled as it was with backbreaking labor from sunup to sundown and the constant element of danger, left little time for woodsmen to create mythical figures. They worked, after all, in

". . . a place where trees from five to fifteen feet through, and as high as a twenty-five-story building topple, where steel cables reaching out two thousand feet into the forest may suddenly come taut and slash out life at a single blow, where monstrous logs may swerve crazily and knock a whole crew into oblivion, where men climb hundreds of feet to the top of 'spar trees,' taking their lives in their hands each time, or where a forest fire may endanger the whole camp -- such a place is not the safest in the world."<sup>94</sup>

Rather than filling their free time swapping tall tales, Holbrook describes lumberjacks as singing dolorous folk songs filled with descriptions of quick or painful deaths on the job.<sup>95</sup> Logging was dangerous and, despite the advances made possible by railroad logging, still highly seasonal in many regions. It experienced both high labor turnover rates and one of the worst occupational safety records. As late as 1950, after the introduction of mechanized equipment, e.g., tracked crawlers, with safety cages for operators, hard hats and safety toed boots, and an overall growing concern

---

<sup>93</sup> Nelligan, p. 10.

<sup>94</sup> "Thus Paul Bunyan's sons gamble with death," *Literary Digest* November 21, 1931:28 + , p. 30.

<sup>95</sup> Holbrook, pp. 130-42. Holbrook cites lyrics of lumberjack music, which he labels as "long-winded bathos" and "maudlin," and provides the following example: "Now when the boys up at the camp/the news they came to hear,/In search of their dead bodies to the/river they did steer./And they found to their surprise, their/sorrow, grief, and woe,/All bruised and mangled on the beach lay/the corpse of young Monroe." According to Holbrook, who spent most of his life around lumbercamps, lumberjacks between 1890 and 1940 were obsessed with only two things, death and women.

with preventing on-the-job injuries, Leland Hooker reported that an average of one out of every six loggers was injured annually.<sup>96</sup> Despite this, many loggers resisted change. Holbrook notes that they “changed their methods very slowly, looking askance at every new element, changing to power equipment only when driven to it by the hungry maws of the mills, holding fast to oxen and then horses until long after those animals were extinct in most industries. . . .”<sup>97</sup>

This alleged conservatism may partially explain why although subtle differences in logging practices existed from region to region, differences there were sometimes dictated by the local topography or species of timber being harvested and sometimes by personal preference, generally a logger could travel from Maine to Louisiana, from the Carolinas to the Pacific Northwest, and not be surprised by any equipment he saw being used. No matter where the logger was employed, in-woods equipment used for felling consisted of axes, crosscut saws, and buck saws<sup>98</sup>, and the work was organized similarly regardless of whether the timber being felled was located in Pennsylvania or California. In the heyday of the white pine logging in Michigan, for example, the operations involved in cutting and moving one log might involve a dozen different men. A two-man crosscut saw team felled the tree, it was limbed and cut to sawlog lengths by the bucking crew, and other men using logging tongs or a two-man comealong would move it to a point where a chain could be attached for individual skidding by a teamster with a horse to a temporary landing in the woods. From that landing logs would be hauled out to a larger landing, either through the use of a big wheel in the summer or on sledges in the winter, to await final transport to the mill. A jammer crew piled the logs at the landing, and, if the landing were at a railroad siding, later transferred the logs from the deck to the railroad cars. This jammer crew consisted of two men who attached and detached the cabling or chains to the logs and directed the guide cables, and the jammer operator who controlled the winch. (See Figure 8 on page 33) The winch was variously powered by horses, steam engines, i.e., donkey engines, or gasoline engines, depending both upon the time period and

---

<sup>96</sup> Leland Hooker, *Woods Safety Handbook* (Houghton, MI: Forest Products Research Division, Michigan College of Mines, 1950).

<sup>97</sup> Holbrook, p. 39.

<sup>98</sup> Also known as Swede saws or bow saws.



the solvency of the company doing the logging. The larger firms such as Diamond Match Company or Weyerhaeuser were more likely to invest in power equipment than the small, independent contractors. If the jammer was horse-powered, the crew included a teamster.<sup>99</sup> In other regions, topography and type of timber harvested could affect the size of the logging crew involved in harvesting each stem. In the smaller timber of the South and the pulpwood forests of Canada instead of a two-man crosscut saw team, individual sawyers armed with bow saws felled trees,<sup>100</sup> while the large timber of the Pacific Northwest required additional workers, e.g., swampers who would prepare the path where the tree would fall. High-lead and sky-line cable logging systems called for workers with additional and different skills, as did logging which utilized river drives. Not every logger wanted to -- or could be -- a drover.<sup>101</sup>

The introduction of the internal combustion engine and the subsequent development of both trucks and agricultural equipment influenced logging, but did not alter the basic technological frame of reference, i.e., the overall management philosophy or worldview, the industry operated within. Although articles in both the trade journals and the popular press enthusiastically described the "rapid mechanization" of the logging industry,<sup>102</sup> the realities of the work did not appreciably change for the workers. Teamsters became mechanics as crawler-tractors replaced horses and oxen, but although the motive power source changed, the basic methodology did not. The workers were still on the ground, both in the woods and in the millyard, in direct contact with the timber as they attached and detached chains and cabling, used peaveys and cant hooks to manipulate logs, and even -- in the case of the pulpwood industry -- picked up and carried the bolts from one location to another (See Figure 9 on page 34). If anything, the mechanization introduced in the years prior to World War II may have increased manpower requirements rather than reducing them: Increased

---

<sup>99</sup> Retired woodworkers interviewed reported seeing horse powered jammers in use in the 1950s in Upper Michigan, and technical literature such as Hooker (1950) and A. Koroleff, *Pulpwood Hauling with Horse and Sleigh: Efficiency of Technique* (Pulp and Paper Research Institute of Canada, 1947) assumes horses still play a major role in forest harvesting.

<sup>100</sup> See Radforth, Van Tassel, Brown.

<sup>101</sup> See Nelligan, Holbrook (1937).

<sup>102</sup> See for example John E. Lodge, "Amazing machines speed work of lumberjacks," *Popular Science* 127(September 1935):25-8 +; A. Koroleff, "Mechanization of logging," *Pulp and Paper Magazine of Canada* 38(October 1937):757-58; and "Logging goes modern," *Popular Mechanics* 72(1939):17-24.

efficiency of technique in hauling entailed increased levels of in-woods production. By the 1930s the overall pace of logging had speeded up, the call for rationalization in the forest products industry had been issued, and the pressure for more fundamental changes had begun to build.<sup>103</sup> A system which had existed in an unstable equilibrium for fifty years -- e.g., labor problems had been a nagging problem since the nineteenth century<sup>104</sup> -- but nonetheless resisted change and reached the middle of the twentieth century still firmly rooted in the nineteenth would soon experience the "creative destruction"<sup>105</sup> of radical technological innovation. And, like many radical innovations, the agents for change would come from outside the system, not from within.<sup>106</sup>

As noted above, sources of motive power changed in the first few decades of the twentieth century. The development of internal combustion and diesel engines led to not only automobiles but also to trucks and tractors. Steam tractors had been around since the 1850s,<sup>107</sup> and had been employed for log-hauling as early as 1885 (See Figure 10 on page 39), but steam power had distinct limitations. Agricultural tractors powered by diesel fuel or gasoline could achieve greater speed and mobility than steam tractors, and the addition of crawler tracks gave them comparable traction and power. By the mid-1920s someone had thought to add a scraper blade to the front of a crawler-tractor and the bulldozer was born.<sup>108</sup> Although the LaPlant-Choate Co. reportedly employed a hydraulic control unit to raise and lower a bulldozer blade as early as 1928,<sup>109</sup> most heavy equipment initially used cable systems to operate blades or dump buckets.

---

<sup>103</sup> See Andrew R. Boone, "Flexible power in the woods," *Scientific American* 160(May 1939):304-5; Adelbert Ebner, "Forest transportation problems," *Pulp and Paper Magazine of Canada* 37(November 1936):704-12.

<sup>104</sup> Lumberworkers had gone on strike as early as 1870 in Pennsylvania and 1882 in Michigan (Holbrook, pp. 105-6).

<sup>105</sup> Rosegger, p.258.

<sup>106</sup> The role of the "outsider" in acting as a change agent has been noted by many historians of technology. See, for example, Constant, p. 17 and p. 178, or Hughes, 1989, p. 59, in which Hughes describes the typical successful inventor-entrepreneur as having "an outsider's mentality."

<sup>107</sup> R. B. Gray, *The Agricultural Tractor, 1855-1950* (St. Joseph, MI: American Society of Agricultural Engineers, 1974).

<sup>108</sup> "The big dirt diggers," *Fortune* January 1945:130-41, p. 135.

<sup>109</sup> "Big dirt," p. 135.

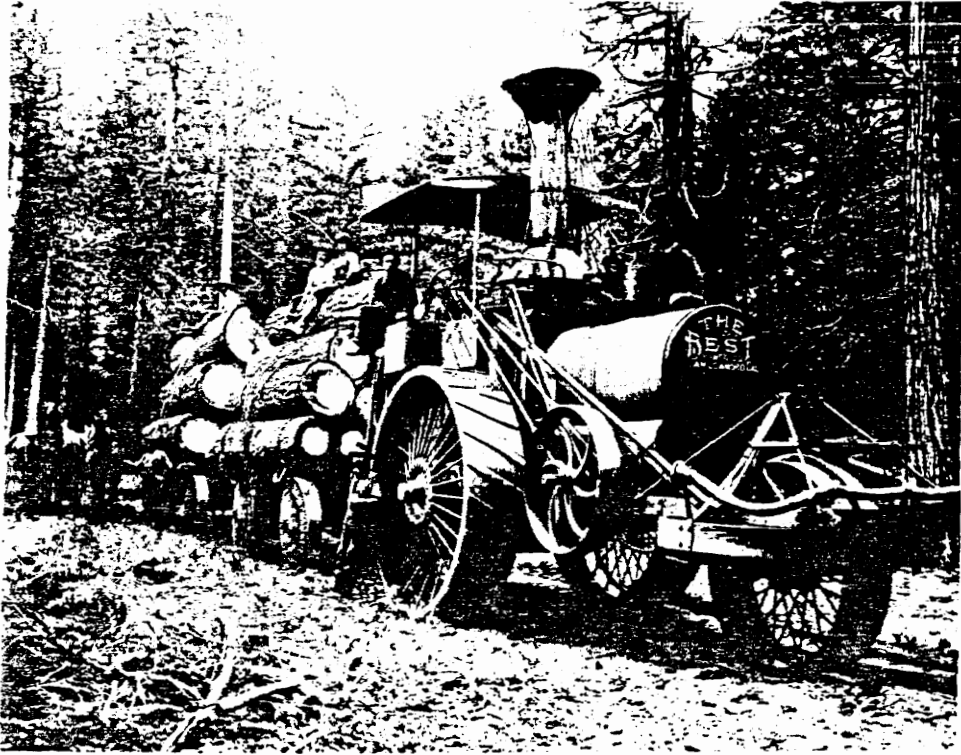

C. L. Best Steam Tractor (vertical fire tube boiler), 1885.  
Space between firebox and outer shell formed the water leg and made  
place for mud to collect.

(From R. B. Gray, *The Agricultural Tractor: 1885-1950* (St. Joseph, MI: American Society of Agricultural Engineers, 1974), p. 10.)

Figure 10. Steam tractor c.1885.

---

Concurrent with changes in agricultural and construction equipment, the use of hydraulics for transmitting power increased. Although World War II and defense-related industry had a tremendous impact on research and development in fluid mechanics, the use of hydraulics for transmission of power was common long before either World War II or the widespread growth of aviation. Hydraulic control of the wicket gates in hydroelectric facilities, for example, had become quite sophisticated by the turn of the century, and firms such as Lombard, Woodward, and Allis-Chalmers competed in designing and marketing governor systems for reaction turbines.<sup>110</sup> In a powerhouse as in factory settings where hydraulic motors powered machine tools, fittings and tubing were made of metal. Flexible hoses were not required until the development of self-contained hydraulic generators eliminated the need for external oil storage tanks. This made possible the move of hydraulic equipment away from fixed locations in buildings and into applications on farm machinery, automobiles, and aircraft in the 1920s and 1930s.<sup>111</sup> The automobile industry developed automatic hydraulic transmissions and hydraulic brakes for passenger cars, hydraulic power lifts for construction and farm equipment appeared, and aviation engineers began to design hydraulic control systems for the ailerons and stabilizers on aircraft.<sup>112</sup>

The interest in finding new applications for hydraulic systems increased awareness of existing weaknesses, e.g., materials used for packing and seals tended to leak, but developments in what H. C. Town termed "collateral fields"<sup>113</sup> had to occur before hydraulic operations could be used as efficiently as engineers and inventors hoped. What Hughes has termed reverse salients, i.e., "components in a system that have fallen behind or are out of phase with the others,"<sup>114</sup> have long been known to both engineers and to economists who recognized that development in any area

---

<sup>110</sup> Duncan Hay, *Hydroelectric Development in the United States, 1880-1940*, manuscript prepared for the Edison Electric Institute (New York: 1989), p. 95.

<sup>111</sup> See for example "Welco self-contained hydraulic generator," *American Machinist* 77(June 7, 1933): 385.

<sup>112</sup> See "Bulldozer blade controlled by hydraulic cylinder," *Engineering News-Record* April 2, 1931:579; "1/2-cubic yard hydraulic loading shovel," *Engineering* September 30, 1938:403; "Hydraulically-operated farm machinery: the Ferguson farm tractor," *The Engineer* August 28, 1936:206.

<sup>113</sup> H. C. Town, "Recent developments in the use of hydraulic power," *Institute of Mechanical Engineers Journal and Proceedings* 143(May 1940):Proceedings 129-41.

<sup>114</sup> Hughes, 1989, p. 73.

tends to proceed unevenly. Rosegger notes that “. . . [inventions] may lie dormant for long periods of time, either because their implementation requires additional technological knowledge or because their development is not (yet) economically attractive.”<sup>115</sup> As the labor situation worsened In the 1920s and 1930s, the desire for innovation in logging steadily increased, but the means to achieve significant changes still did not exist. Without the sense of urgency World War II generated in society as a whole, it is possible the technical problems confronting would-be inventors and innovators would have gone unaddressed much longer; instead, by 1945 technical advances in fields as diverse as aviation and armament would begin to diffuse into a wider community.<sup>116</sup> These advances would make possible different concepts of how work should be done in construction, in agriculture, in manufacturing, and in logging.

---

<sup>115</sup> Rosegger, p. 7.

<sup>116</sup> See Harry J. Marx, “Aircraft experience aids industrial hydraulics,” *Machine Design* 15(September/October 1943):91-5, 100-04; “The Parnall power-operated gun turret,” *Engineering* 154(November 6, 1942):366-67, 370; John W. Kelly, “Design simplicity prerequisite of hydraulic control standardization,” *Aero Digest* 41(December 1942):211 +; S. I. MacDuff and G. A. Goepfrich, “Hydraulic machine gun chargers,” *Aero Digest* 42(February 1943):243-44 +; and Christian E. Grosser, “Hydraulic leakage can be controlled,” *Machine Design* 14(August 1942):70-3.

## Chapter Four: Winds of Change

The origins of change that led to the development of devices such as the Pettibone Cary-Lift and the Franklin Skidder are widely scattered across a variety of fields. They can be found in such diverse areas as the industry's growing recognition changes were necessary, advances in hydraulics in aviation technology, the spread of vocational education in American high schools, the availability of mass circulation periodicals such as *Popular Mechanics* and *Popular Science*, the time-honored craftsmen's tradition of tinkering, and doubtless in many other areas as well. Tracing the origins of any innovation can be difficult, as Rosegger notes:

the antecedents of major innovations are typically spread across time and a variety of technical fields. Therefore, even carefully worked out chronologies may reveal no more than the most important interconnections among events. The picture is further complicated by multiple, independent inventions, by long lags, by the pursuit of technical dead ends, by competitive development work, and by situations in which one developer proceeded in total ignorance of another's parallel efforts.<sup>117</sup>

This appears to be especially true of the history of loading and skidding equipment in logging. This chapter will explore a few of the social, economic, and technical factors that may or may not have contributed to technological innovation.

---

<sup>117</sup> Rosegger, p. 155.

## The Call for Rationalization in the Woods

By the end of World War II, the confluence of economic, social, and technical conditions within society as a whole and conditions within the logging industry appeared to make it ready for major changes. The war exacerbated both labor shortages and labor grievances. Although woodwork was considered vital to the war effort and loggers were exempt from the draft, many men preferred to serve their country in the armed forces. Moreover, despite the importance of woodwork to the war effort, throughout the war the relationship between management and labor worsened as a series of strikes and threatened strikes slowed production.<sup>118</sup> Management tried to compensate for this shrinking and increasingly militant labor pool by recruiting women,<sup>119</sup> establishing prisoner of war camps in lumbering and pulpwood regions,<sup>120</sup> and trying to improve existing production tools.

In a 1942 article in *Pulp and Paper Magazine of Canada* J. A. McNally began by optimistically reporting that "tool manufacturers, logging companies and associations, and workmen have striven through experiment, research and study to re-design old tools and design new ones for specific jobs, in order that production might be increased for their mutual advantage,"<sup>121</sup> but then went on to predict "magnesium alloy steel frames"<sup>122</sup> for bow saws and the standardization of pulpwood hooks.<sup>123</sup> The industry recognized the need for innovation but remained locked into an existing technological frame. Innovation and mechanization were seen as useful in improving efficiency, but no fundamental changes in the overall organization of work within the system were anticipated.

---

<sup>118</sup> See "Again," p. 26; "Unrest in woods," *Business Week* December 13, 1941:74-6; "Wanted: Loggers," pp. 57-8; "Walkout shrinks," *Business Week* June 3, 1944:107+.

<sup>119</sup> "Literal log jam," *Business Week* August 15, 1942:64.

<sup>120</sup> See for example Arthur W. Baum, "Revolution in the pines," *Saturday Evening Post* 217(July 22, 1944):22-3+, p. 22.

<sup>121</sup> J. A. McNally, "Logging tools are greatly improved," *Pulp and Paper Magazine of Canada* 43(July 42):627-8.

<sup>122</sup> McNally, p. 627.

<sup>123</sup> McNally, p. 627.

When the war ended, forest engineers noted approvingly that "there was a widespread introduction of mechanical equipment"<sup>124</sup> in the industry, but an examination of trade literature reveals that this equipment consisted primarily of crawler-tractors and prototype chain saws.<sup>125</sup> Moving and loading the wood continued much as it had for decades: Jammers and similar cable yarders and loaders (See Figure 6 on page 29). Professionals within the industry recognized the drawbacks implicit in the usual loading techniques. Accidents involving the jammer or the jammer crew were frequent.<sup>126</sup> Writing in 1947 Gordon Godwin stated, "Much has to be done on this loading problem. It is the toughest and least attractive job offered to hand labor and one of the most expensive single operations involved in logging."<sup>127</sup> Godwin argued that one problem delaying mechanization in logging was management attitudes:

Top management in many instances seems to think that having determined on mechanization, it is only necessary to order a few carloads of trucks, tractors, and power saws, and presto! the job is done. Management must understand we cannot implement mechanization by turning a switch. We don't operate under a factory roof but over many thousand of square miles in country which ranges from black spruce swamp to precipitous mountains. . . . We have very specific and unusual engineering problems to overcome. When our industry realizes that woodlands operation is at least as complicated as mill operation we will reach top speed in our progress toward reducing costs by logging mechanization.<sup>128</sup>

Godwin apparently believed that a lack of support for organized research and development was the major reason for delay in mechanization. B. J. McColl agreed with Godwin that logging presented unique engineering challenges and advocated change being implemented from the top down, through aggressive research and development efforts on a corporate level. In addition, McColl believed that the pace of mechanization could be speeded and "much time and money be saved if a free exchange of information is maintained."<sup>129</sup> McColl and Godwin were apparently unaware

---

<sup>124</sup> Collet, p. 1204.

<sup>125</sup> See McNally; Collet; Jacques Girouard, "Mechanized logging at Forestville," *Pulp and Paper Magazine of Canada* 49(June 1948):111-14.

<sup>126</sup> See for example "Two killed Monday at Northwoods Sawmill in Baraga," *L'Anse Sentinel* August 2, 1944:1.

<sup>127</sup> Gordon Godwin, "Problems of mechanized logging," *Journal of Forestry* 45(August 1947):549-54, p. 552.

<sup>128</sup> Godwin, p. 553.

<sup>129</sup> B. J. McColl, "Woodlands mechanization," *Pulp and Paper Magazine of Canada* 49(September 1948):125-6, p. 126. cf. Radforth, pp. 179-200; W. A. E. Pepler and B. J. McColl, "The status of mechanization," *Pulp and Paper Magazine of Canada* 50(May 1949):154+.



that the winds of change had already begun to blow through the hardwood stands of the Lake States.

## The Drott Loader

By 1945 a loader radically different from traditional jammers, swing boom, and skid loaders appeared in the woods of the Midwest and would soon find employment as far south as the Mississippi pines: the Drott Loader.<sup>130</sup> (See Figure 11 on page 46) The Drott Loader, developed by E. A. Drott of Milwaukee, Wisconsin, used a crawler-tractor as a carrier vehicle for a loader that took principles developed for use in bucket loaders<sup>131</sup> one step farther: rather than a blade or a bucket, the Drott Loader had forks for picking up logs or similar material. *Popular Mechanics* exuberantly reported that:

History was made recently in the Wisconsin woods when a puffing steel giant eased up to a wood pile, slipped strong arms around a cord of wood, lifted it high and then deposited the heavy load in a truck. The entire operation required just a minute and a half -- a job which would have taken 25 husky men to handle in the same time. . . . The steel arms which do the loading, clamping, and lifting are mounted on a Diesel tractor. First, the tractor pushes the two lower "skid" arms into a stack of pulpwood. Then the top arm, which is hydraulically operated, is dropped down on the pile, holding the load firmly against the lower arms. When the load is secure, the entire mechanism is tilted back, lifting the two arms to a 45-degree angle high over the driver's head. The tractor backs away from the pile and lowers the tightly-clamped load onto ski runners which are shoved along to where the load is to be dumped. There the arms are again raised to a 45-degree angle, and after getting into proper position, the "skid" arms open like those of a man over a woodbox.<sup>132</sup>

Although Drott called it a skid-loader, apparently because the load was skidded along the ground rather than actually carried, his machine differed significantly from other so-called skid loaders then in use. (See Figure 12 on page 47) He had, in effect, crossed a fork-lift with a bulldozer and so created the first widely commercially available example of a new breed of machines.

---

<sup>130</sup> Nelson Courtland Brown, *Logging: The Principles and Methods of Harvesting Timber in the United States and Canada* (New York: John Wiley & Sons, 1949), p. 258.

<sup>131</sup> cf. "1/2-cubic yard."

<sup>132</sup> "Iron arms move cord of wood in 90 seconds," *Popular Mechanics* May 1945:57.

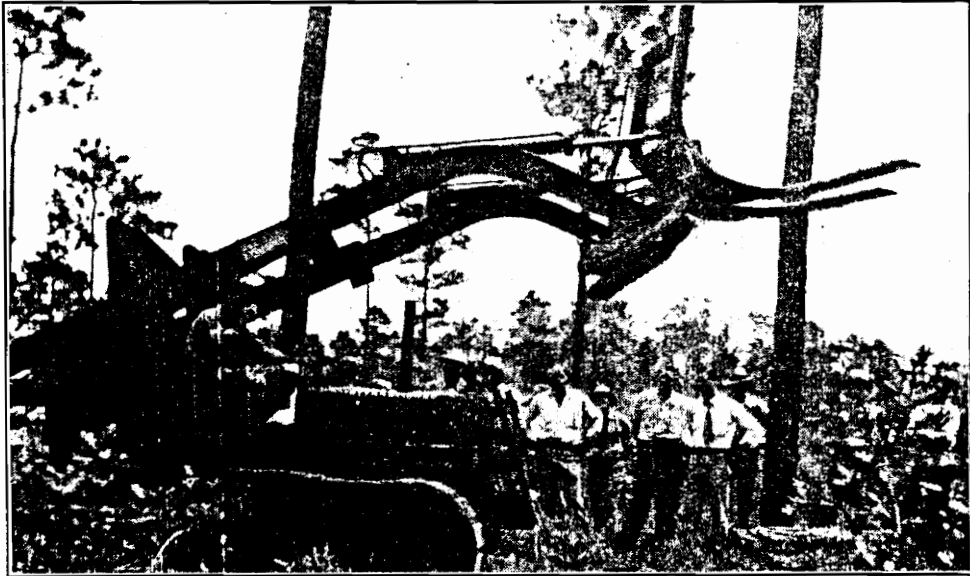

FIGURE 99. Drott portable skid loader mounted on International tractor. Used for assembling and loading small logs and pulpwood in southern pine. The sharp points of the loader pick up logs or pulpwood and drop them on a truck located in the rear of the loader. It is widely used in the Lake States, Canada, and the East, as well as in the South.

(From Nelson Courtland Brown, *Logging* (John Wiley & Sons, 1949), p. 225.)

Figure 11. The Drott Loader.

---

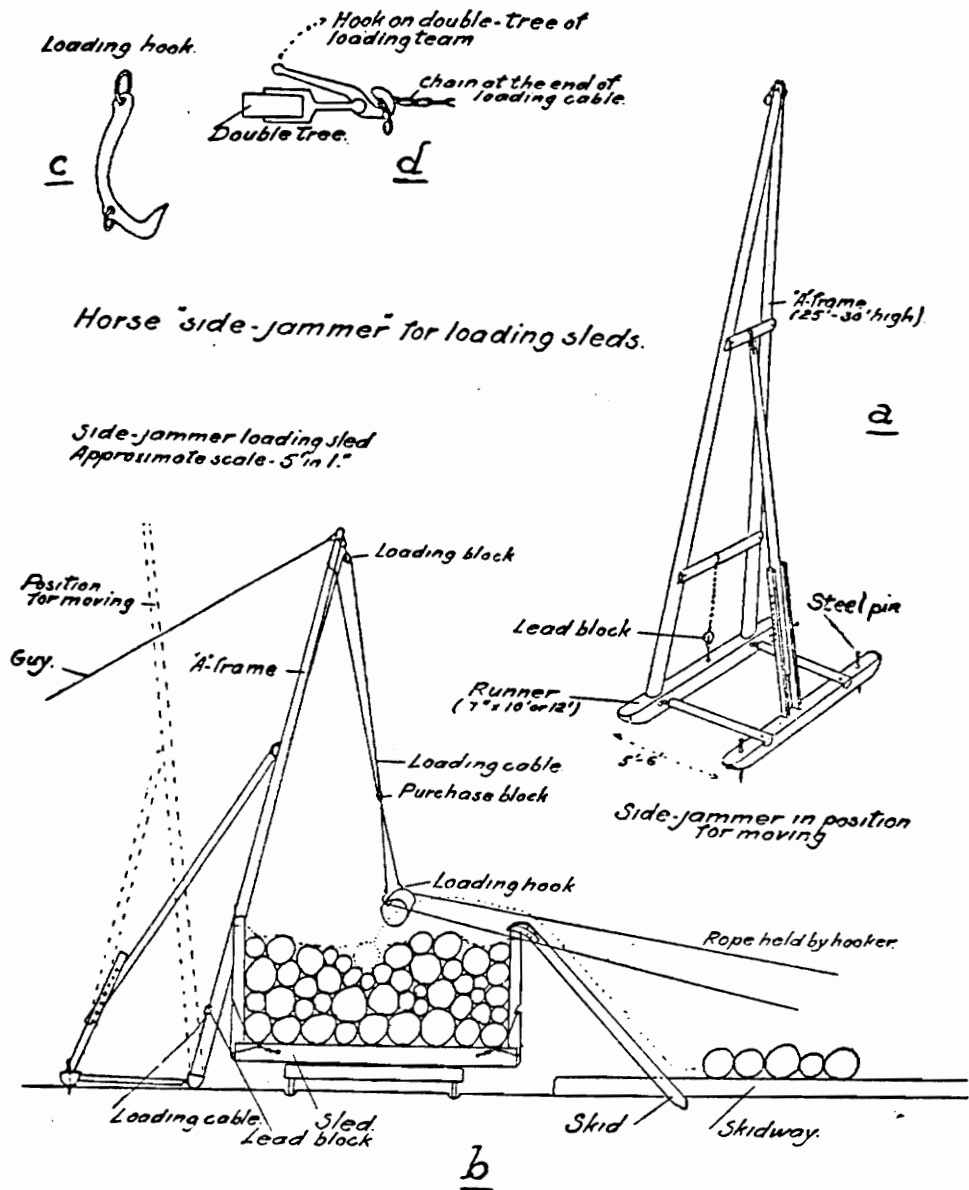

Fig. 44. Horse-jammer for loading sleighs. (a)—Jammer in position for moving. (b)—Loading a sleigh.—(c) Loading hook. (d)—Trip-hook attached to the whiffletree of the loading team by means of which the loading line may be released instantly.

(From Koroleff, 1947, p. 111.)

Figure 12. A skid loader.

The Drott loader was not, however, the first attempt at an easily portable loader. A variety of portable bucket and conveyer loaders had been developed for use in construction, forklifts had been used in warehouse operations for many years, and Hyster manufactured a specialized loader for moving stacks of lumber in lumberyards.<sup>133</sup> Unfortunately, none of these types of machines was suitable for use in the rough terrain of a logging site (See Figure 13 on page 49).

## The Possible Role of Popular Periodicals

The Drott loader was also not the first attempt at a fork-lift type loader for use outdoors. In 1943 *Popular Science* published a photo essay on the efforts of a high school vocational education class in Tremont, Utah, to develop loaders for agricultural use (See Figure 14 on page 50). The report noted that serious manpower shortages caused by the war had led local farmers to ask the shop teacher to challenge his students to devise loaders which could be cheaply built from scrap materials using ordinary farm tractors as carrier machines. The resulting loaders shared a common characteristic in their home-built appearances, but employed a variety of mechanisms for operating the loader. Some used hydraulics, others cable, but apparently they all worked as they were intended to.<sup>134</sup> Did this article in *Popular Science* inspire Drott's design? Considering that Drott was already an established firm specializing in construction equipment, it seems unlikely, and there is no way to ever know for sure if it played an influential role or not. What it is evidence of is the continuing strong interest in tinkering, in being a backyard inventor, characteristic of some segments of American society, and the role that magazines such as *Popular Science* could play in encouraging that interest.

Many would-be inventors have lacked a formal engineering or scientific education,<sup>135</sup> but periodicals such as *Popular Science* and *Popular Mechanics* with their do-it-yourself instructions for

---

<sup>133</sup> See E. W. Weaver, "Mechanical load handling equipment," *Welding Journal* 22(August 1943):619-23.

<sup>134</sup> "Ingenious loaders built from scrap," *Popular Science* 143(December 1943):200-01.

<sup>135</sup> Historians of science often point to Thomas Edison as the "quintessential technologist." Certainly he reigns

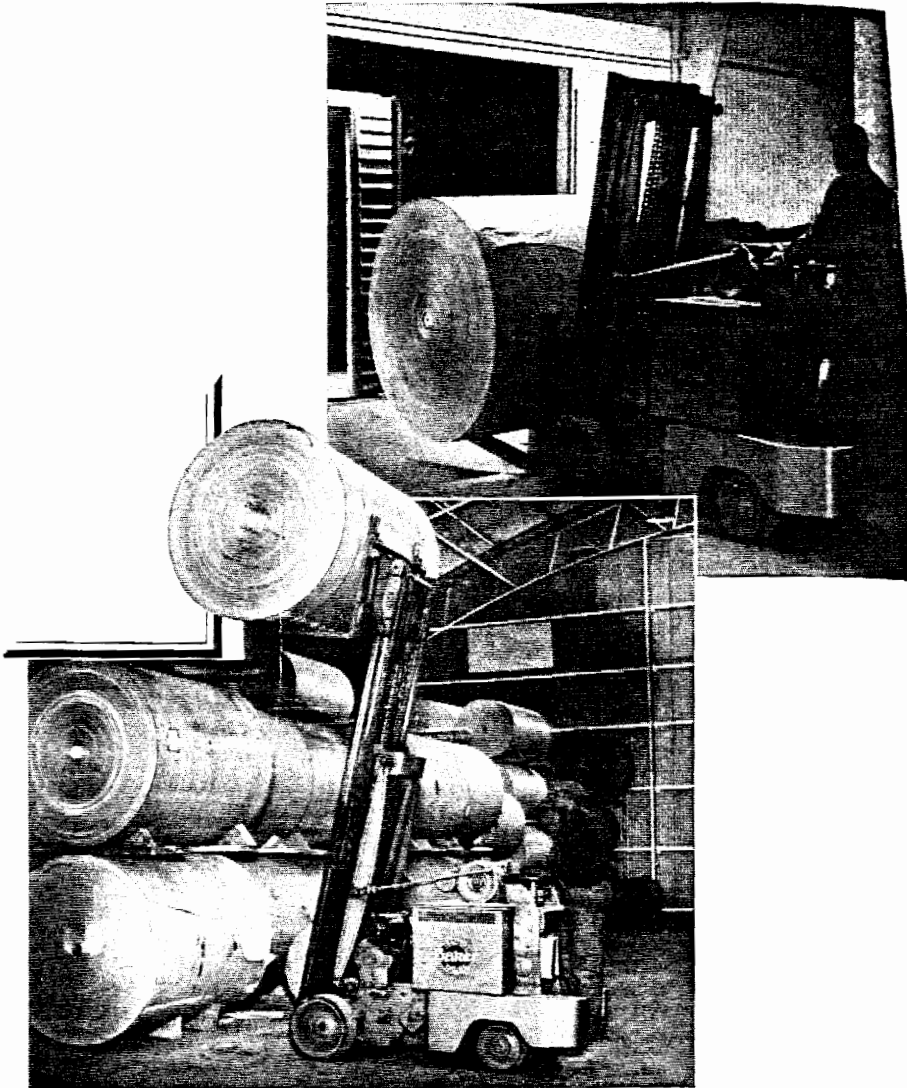
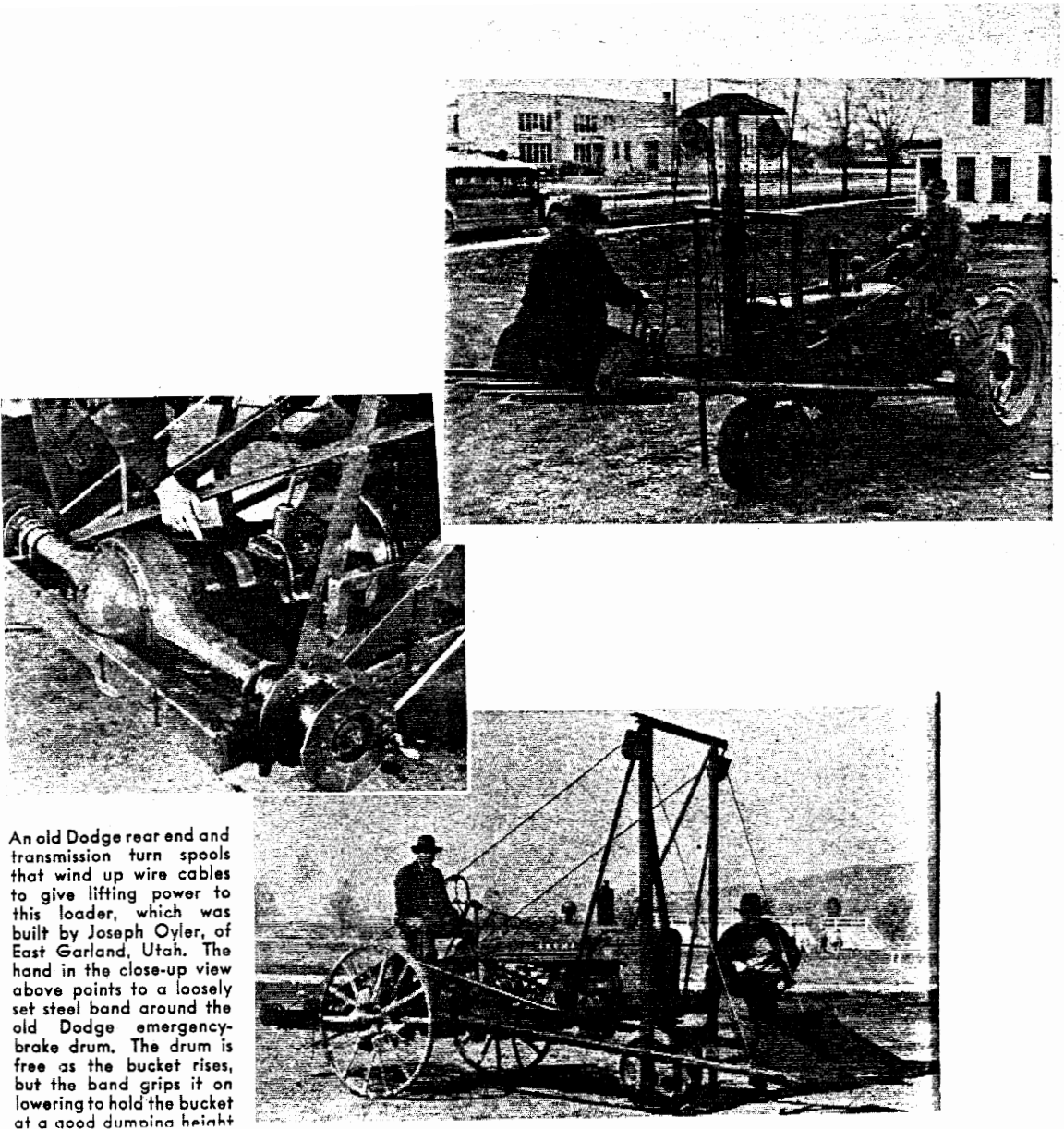

Figure 13. Conventional forklift.

---



An old Dodge rear end and transmission turn spools that wind up wire cables to give lifting power to this loader, which was built by Joseph Oyler, of East Garland, Utah. The hand in the close-up view above points to a loosely set steel band around the old Dodge emergency-brake drum. The drum is free as the bucket rises, but the band grips it on lowering to hold the bucket at a good dumping height

(From "Ingenious loaders built from scrap," *Popular Science* 143(December 1943), pp. 200-01.)

Figure 14. Loaders built by a Utah high school shop class.

building everything from magazine stands to garden tractors<sup>136</sup> surely helped creative individuals compensate for such gaps. While professional engineers and managers in the logging community were bemoaning the lack of communication within that community,<sup>137</sup> a wider network for promulgating new ideas across disciplinary boundaries already existed: once a month the general public read mass market magazines which removed the mystery from recent advances in electronics, aviation, automobiles, hydraulics, and a host of other areas. In addition, not only did these periodicals offer explanations and directions in layman's language, every issue featured readers contributions which could range from simple hints for organizing the hand tools in a home workshop to descriptions and photographs of the results of complex and technically sophisticated do-it-yourself projects. Independent inventors frequently are "important sources of idea leading to major innovations"<sup>138</sup> and, while they have achieved fame and fortune often enough in the past to provide continuing inspiration to other would-be inventors, periodicals such as *Popular Mechanics* served to reinforce what some analysts believe is a primary motive for inventive activity -- it is fun<sup>139</sup> -- by providing a forum in which inventors could share their personal success stories. Eugene S. Ferguson has argued that for inventions "to be carried beyond their first tentative ideas, it is clear a culture must encourage them,"<sup>140</sup> and notes the role *Scientific American* played in fostering the inventive spirit in nineteenth century America.<sup>141</sup> Like Rosegger and others, Ferguson concludes that ultimately the prime motivation of most inventors is the fun -- the intellectual excitement<sup>142</sup> -- of solving technical problems.

---

supreme in American folklore as the quintessential inventor. See John P. McKelvey, "Science and technology: the driver and the driven," *Technology Review* 88 (January 1985):38-47.

<sup>136</sup> See, for example, H. Suddaby, "Tractor built from old car parts without machining," *Popular Mechanics* 71(1939):790-95, 953-55.

<sup>137</sup> See McColl, p. 126.

<sup>138</sup> Rosegger, p. 161.

<sup>139</sup> Rosegger, p. 144.

<sup>140</sup> Eugene S. Ferguson, "The nature of play and the intellect," manuscript prepared for the Annual Meeting of the American Anthropological Association, Washington, D.C., 1980, p. 6.

<sup>141</sup> *Scientific American* apparently actively solicited patents from its readership. Ferguson, p. 7.

<sup>142</sup> Ferguson, p. 8.

## The Availability of Vocational Education

Coexisting with the wide circulation of these periodicals was the growing availability of vocational education in public high schools. Manual training had first been introduced into the public school curriculum in the nineteenth century when the first industrial arts high school, the Manual Training School of Washington University, opened in St. Louis, Missouri, in 1879.<sup>143</sup> The National Education Association issued a resolution formally supporting manual training at their Chicago convention in 1887, and vocational education in some form or another had been part of most school curricula since the turn of the century. Although the Great Depression had lessened support for industrial arts in the 1930s, most public schools still offered shop courses. World War II, of course, revived interest in the manual arts and the public once again began actively supporting machine shop, welding shop, and wood shop classes.<sup>144</sup> The Utah shop class with its attempt to design loaders was no doubt typical of many efforts made by shop teacher nationwide as they encouraged students to find creative solutions to wartime manpower and materials shortages.<sup>145</sup>

---

<sup>143</sup> This movement toward training in industrial arts in the secondary schools followed the development of public agricultural and mechanical colleges by only a few years -- the Morrill Act of 1864 authorized the establishment of the land grant colleges to train engineers and technicians -- and it is probable many high school vocational education teachers received their training at schools such as the University of Wisconsin and Texas A & M.

<sup>144</sup> For more information on the history of vocational education in the United States, see Richard Barella and Thomas Wright, editors, *An Interpretive History of Industrial Arts: The Interrelationship of Society, Education, and Industrial Arts* (American Council on Industrial Arts Teacher Education, 1981); Charles Alpheus Bennett, *History of Manual and Industrial Education* (The Manual Arts Press, 1937); and Rupert N. Evans, *Foundations of Vocational Education* (Columbus, OH: Charles E. Merrill Publishing Company, 1971).

<sup>145</sup> "Ingenious."



## Systemic Inertia

Regardless of the sources of inspiration for the Drott loader, whether it was an elaboration of ideas freely circulated or truly an independent invention “based on the same principle as man who picks up an armful of firewood,”<sup>146</sup> it does appear to have been the first pulpwood loader of its general type. Despite its widespread acceptance,<sup>147</sup> its design was not, however, immediately imitated.<sup>148</sup> Instead, the next few years witnessed additional variations on the traditional jammers and swing boom loaders.

In August 1947 the American Pulpwood Association (APA) Technical Release 2, for example, provided directions for building a jammer similar to the one developed by L. A. Kendall, “an operator associated with the Minnesota & Ontario Paper Company,” who used a salvaged Model A engine as a power source (See Figure 15 on page 55)<sup>149</sup> while APA Technical Release 3 informed American Pulpwood Association members that the Milwaukee Hydraulics Corporation had begun marketing a truck-mounted hydraulic crane that would handle pulpwood using a hydraulic actuated grapple with a capacity of 1/4 cord of wood. According to the manufacturers, “the design is unique in that ram action is employed for rope movement, in lieu of the conventional geared drum winches.<sup>150</sup> Other cranes advertised as suitable for pulpwood loading applications included the Hystaway Crane, “developed [as] an attachment for the standard Caterpillar tractors,”<sup>151</sup> and

---

<sup>146</sup> “Iron arms,” p. 57.

<sup>147</sup> Brown, 1949, p. 245; “Koski Pulpwood Loader,” American Pulpwood Association Technical Release 84, September 22, 1950.

<sup>148</sup> Economists often judge the success of an innovation by the speed with which it is copied. See Rosegger, pp. 178- 98.

<sup>149</sup> “Kendall Jammer,” APA Technical Release 2, August 1, 1947.

<sup>150</sup> “Truck-Mounted Hydraulic Crane,” APA Technical Release 3, August 1, 1947.

<sup>151</sup> APA Technical Release 26, March 10, 1948.

Lorain.<sup>152</sup> Using cranes in the woods was nothing new; before the war Caterpillar had begun trying to sell cranes to loggers for use as loaders.<sup>153</sup>

The Logger's Dream, on the other hand, was portable high-lead cable yarder. The manufacturer, Taylor Machine Works of Louisville, Mississippi, offered six different models of the Logger's Dream, all of which could skid, load, and transport themselves "mounted on any standard chassis."<sup>154</sup> The Logger's Dream and other mobile yarder-loaders such as the Idaho Jammer enjoyed wide usage among loggers following World War II,<sup>155</sup> but as cable-haulback systems were "inseparably connected with clear-cutting methods"<sup>156</sup> they also had distinct limitations. The techniques for high lead cable yarding had been refined over sixty years of use, but it still continued to be the most damaging method to residual stands (See Figure 16 on page 56). This meant high-lead cable yarders were impractical for doing selective cutting in mixed stands or for thinning operations on tree farms.<sup>157</sup> In addition, cable yarding, whether done using new equipment such as the Logger's Dream or employing spar trees and locally built timber-frame jammers, removed none of the risks to the workers that had existed for years. Top-loading in the 1950s was not noticeably less dangerous than top-loading at the turn of the century. (See Figure 17 on page 57 and Figure 18 on page 58)

Rather than using jammers or swing boom loaders, in some areas skid-loading (Figure 12 on page 47), in which the logs were rolled or dragged up on to the load, became common. APA Technical Release 33, issued in November 1948, reported that the Timber Tosser (Figure 19 on page 60) marketed by Timberland Equipment, Inc., at 30 Rockefeller Plaza in New York City,

---

<sup>152</sup> See Advertisements, *Pulp and Paper Magazine of Canada* 51(April 1950):137 and *Pulp and Paper Magazine of Canada* 52(March 1951):125.

<sup>153</sup> See Boone, pp. 304-5; or W. J. Carson, "New uses for tractors on logging operations," *Pulp and Paper Magazine of Canada* 38(September 1937):696-98.

<sup>154</sup> "The Logger's Dream," APA Technical Release 41, January 20, 1949.

<sup>155</sup> See B. J. McColl, "The Logger's Dream," *Pulp and Paper Magazine of Canada* 50(January 1949):132; Stenzel, p. 243.

<sup>156</sup> See Brown, 1949, p. 220; Godwin, p. 554; and B. J. McColl, "Recent developments in mechanical logging," *Pulp and Paper Magazine of Canada* 51(April 1950):128+.

<sup>157</sup> In recent years, sky-line cable systems have been successfully employed for thinning operations, but high-lead continues to be used only for clearcutting. See Stenzel, p. 231.

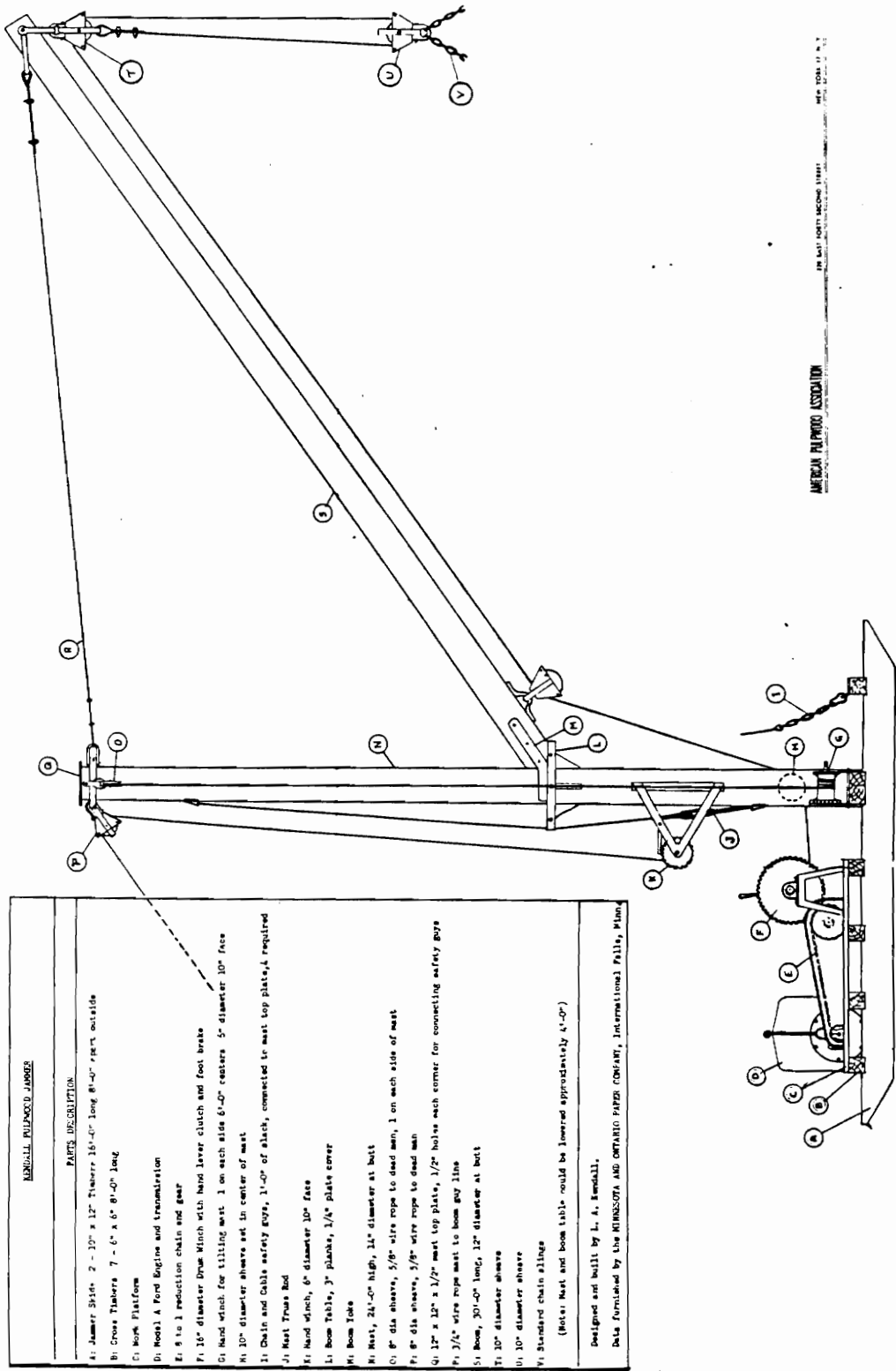

KENDALL PULWOOD JAMMER	
PARTS DESCRIPTION	
A:	Jammer Skin 2 - 10" x 12" Timber 16'-0" long 8'-0" apart outside
B:	Cross Timbers 7 - 6" x 6" 8'-0" long
C:	Work Platform
D:	Model A Ford Engine and transmission
E:	8 to 1 reduction chain and gear
F:	10' diameter Drum Winch with hand lever clutch and foot brake
G:	Hand winch for tilting mast 1 on each side 6'-0" centers 5' diameter 10" face
H:	10' diameter sheave set in center of mast
I:	Chain and Cable safety 80V, 1'-0" of slack, connected to mast top plate, 4 required
J:	Mast Truss Rod
K:	Hand winch, 6' diameter 10" face
L:	Boom Table, 3' planks, 1/4" plate cover
M:	Boom Table
N:	Mast, 24'-0" high, 14" diameter at butt
O:	8" dia sheave, 3/8" wire rope to dead man, 1 on each side of mast
P:	8" dia sheave, 3/8" wire rope to dead man
Q:	12" x 12" x 1/2" mast top plate, 1/2" holes each corner for connecting safety guys
R:	3/4" wire rope mast to boom guy line
S:	Boom, 30'-0" long, 12" diameter at butt
T:	10" diameter sheave
U:	10" diameter sheave
V:	Standard chain alliage

(Note: Mast and boom table could be lowered approximately 4'-0")

Designed and built by L. A. Remohl.  
 Data furnished by the MINNESOTA AND ONTARIO PAPER COMBINE, International Falls, Minn.

AMERICAN PAPER ASSOCIATION  
 100 EAST NORTH WABASH STREET  
 CHICAGO, ILL. U.S.A.

Figure 15. Kendall jammer.

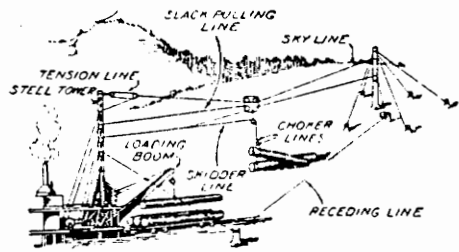

2-A STEEL TOWER SKIDDER SYSTEM

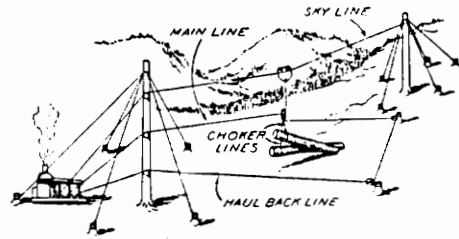

2-E NORTH BEND SYSTEM ONE PART MAIN LINE

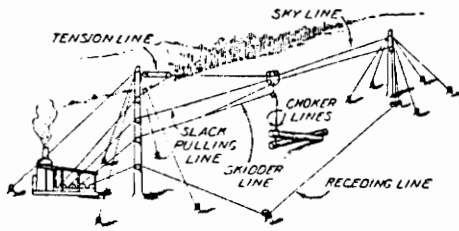

2-B TREE SPAR SKIDDER SYSTEM

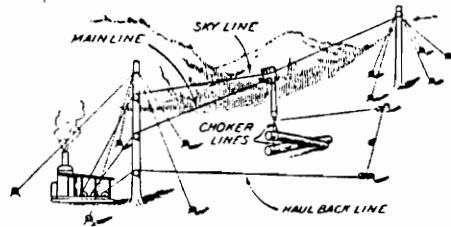

2-F NORTH BEND SYSTEM TWO PART MAIN LINE

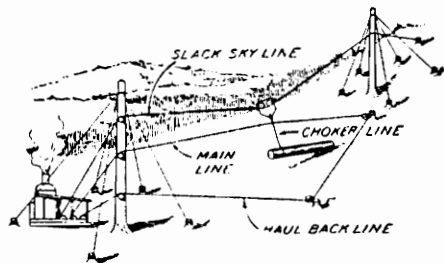

2-C SLACK LINE SYSTEM

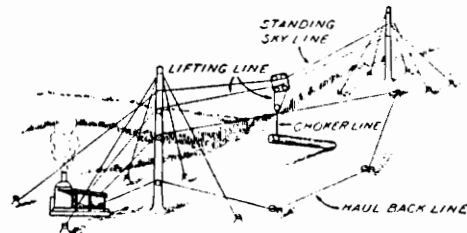

2-G TYLER SYSTEM

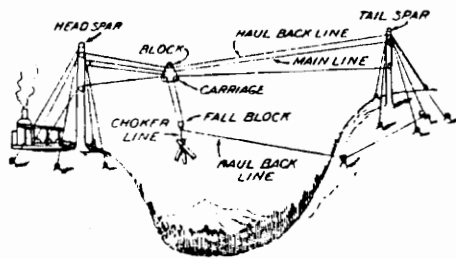

2-D DUNHAM SYSTEM

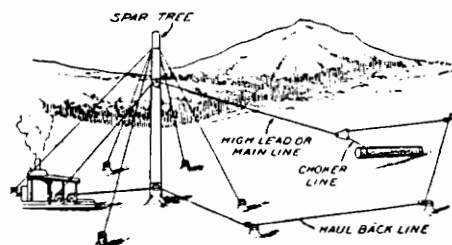

2-H HIGH LEAD SYSTEM

(From Brown, 1934, p. 131.)

Figure 16. Cable yarding systems.



(From Mary Roddis Connor, *A Century with Connor Lumber* (Stevens Point, WI: Worzalla Press, 1972).)

Figure 17. Toploading logs in 1950.

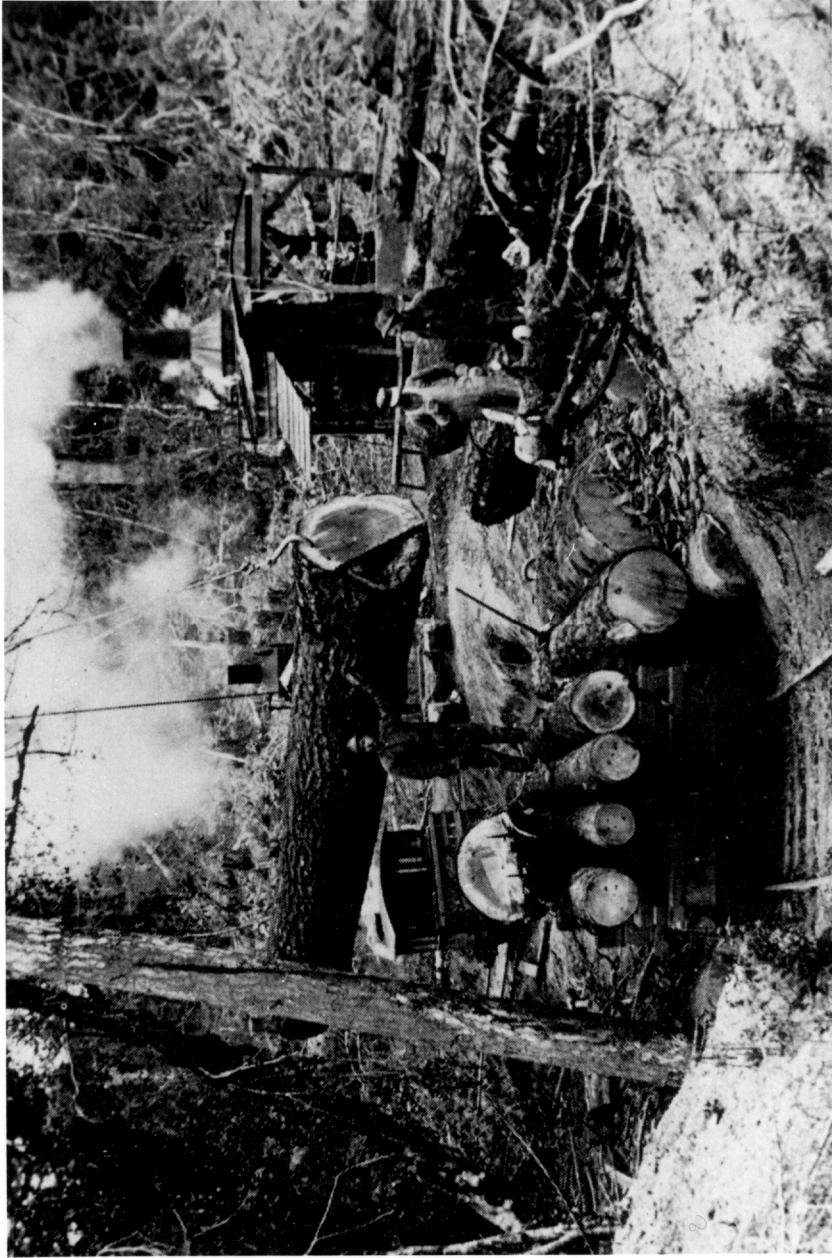

Figure 18. Toploading logs at the turn of the century.

could lift logs "from ground level on to the truck without hooks, slings, or tongs, and without damage to springs, axles, wheels, or frames."<sup>158</sup> These timber tossers seem to constitute a technical dead end and apparently never enjoyed wide usage.<sup>159</sup>

Some interesting variations of the traditional boom loader did appear in the late 1940s. Thomas N. Busch of Georgetown, South Carolina, developed a "High Boom Arch"<sup>160</sup> utilizing Army surplus tracked Athey wagons. A cradle on the wagon could accommodate two 1-cord bundles of pulpwood. The device required careful loading, to ensure uniform bundles, and probably did not result in saving on man-hours required per cord. Axel Koski of Koski Repair Works, Keweenaw Bay, Michigan, also experimented with a modified logging arch. Koski attached the arch directly to a logging tractor, either a Caterpillar D4 or an Allis-Chalmers HD5, and provided two different options. Loggers could chose between a relatively inexpensive cable loader -- \$400 to \$500<sup>161</sup> -- or a hydraulic clam for \$3,000. APA Technical Release 84 described the latter with its swivel clam as being "the first machine of this type which enables the operator to pick up 1/2 cord of pulpwood and set it on a truck bed with complete control of the angle at which the wood is set down."<sup>162</sup> According to W. S. Bromley, the forest engineer who authored the APA technical release, loggers preferred Koski's clam loader over the Drott loader. Bromley stated that Toivo Mattson, a logging contractor for Marathon Corporation, reported that

"The Koski Pulpwood Loader, in addition to being able to place the wood at most any angle desired by the operator, does a much neater job of piling the wood on the truck bed because as the clam releases the pulpwood, the bottom sticks of pulpwood are not disturbed as they frequently are when the forks of the Drott Skid Loader are withdrawn from piles of pulpwood in its use."<sup>163</sup>

Koski's Pulpwood Loader appears to be one of the first in-woods machines to employ a rear clam and bears a striking resemblance to modern grapple skidders, but, like the Drott loader and the

---

<sup>158</sup> "Timber Tossers," APA Technical Release 33, November 24, 1948. cf. reference to Bouffard timber tossers in Brown and elsewhere.

<sup>159</sup> Godwin, p. 552, includes a photo of a Bouffard Log Flipper.

<sup>160</sup> "Busch High Boom Arch," APA Technical Release 29, March 24, 1948.

<sup>161</sup> "Arch Boom Loader," APA Technical Release 83, September 22, 1950.

<sup>162</sup> APA Technical Release 84, September 22, 1950.

<sup>163</sup> "Koski Pulpwood Loader," APA Technical Release 84, September 22, 1950.

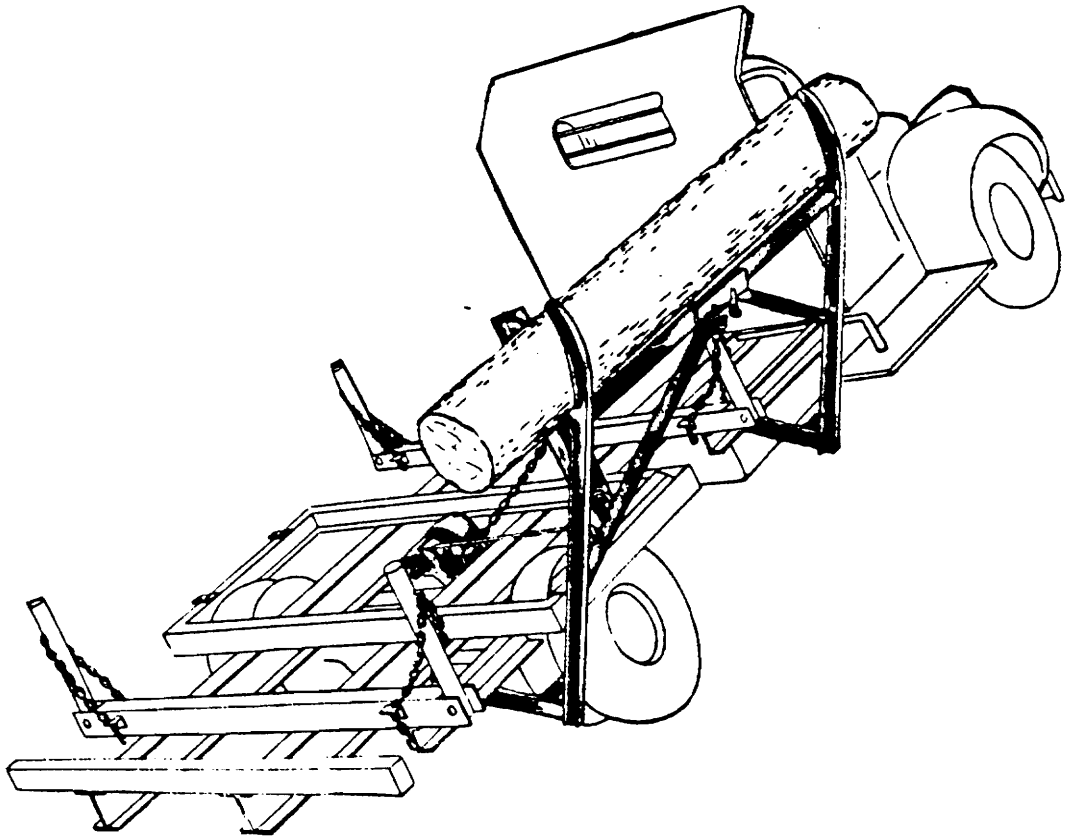

(From American Pulpwood Association Technical Release 33, November 24, 1948.)

Figure 19. The Timberland Timber Tosser.

---



Busch arch, was mounted on a tracked vehicle, and tracked vehicles embody a host of problems in themselves.

Crawler-tractors had been used in logging for a number of years prior to World War II,<sup>164</sup> and, following the war, the wide availability of military surplus tracked vehicles and wagons allowed inventors to experiment with new ideas at a relatively low cost. Nevertheless, tracked vehicles were not necessarily the best choice for woods work. Tracked vehicles often required considerably more time spent on maintenance than wheeled vehicles did, and this requirement for frequent maintenance and repair made at least one inventor resolve not to use a bulldozer as the basis for his machine.

## Philip La Tendresse and the Pettibone Cary-Lift

When Jim Grant of the Northwoods Timber Company approached Philip La Tendresse,<sup>165</sup> a former employee of Koski Repair Works, in 1949 and asked him to build a loader to offload trucks, La Tendresse had been managing Baraga Repair and Service for about five years. Although he was a talented mechanic, La Tendresse appears to be an improbable candidate to fill the role of revolutionary inventor. While he had always enjoyed tinkering -- his son, George La Tendresse, recalls his father telling stories about amusing himself as a young boy by using the springs and gears in clocks to construct racing toys<sup>166</sup> -- he does not appear to have been driven by any overwhelming sense of urgency or mission.<sup>167</sup>

---

<sup>164</sup> See W. J. Carson, "New uses of tractors on logging operations," *Pulp and Paper Magazine of Canada* 38(September 1937):696-98.

<sup>165</sup> Moberg.

<sup>166</sup> George La Tendresse, telephone interview, February 17, 1990.

<sup>167</sup> See Ferguson; Hughes, 1989; or Robert V. Bruce, "The American Style of Invention," *American Patent Law Association Bulletin* June 1976, for an extensive discussion of the entrepreneurial personality.

A lifelong resident of Michigan's Baraga County, Philip La Tendresse was born in the rural community of Keweenaw Bay on May 8, 1914, and attended area schools. He graduated from Baraga High School in 1934 and, although he was reportedly a brilliant student,<sup>168</sup> financial hardship prevented his continuing his education. Unable to attend college, he settled down, married his high school sweetheart, and sought work in the local area as a welder and mechanic. La Tendresse worked first for Phil Foucault at the L'Anse Motor Company in L'Anse, Michigan, and then for Koski Repair Services in Keweenaw Bay.

In 1944 Malvie LeClaire of Baraga bought the Dove Repair Shop and hired La Tendresse to manage the business under the new name of Baraga Repair and Service. Charles Koskinen was put in charge of the blacksmithing component of the business.<sup>169</sup> Baraga Repair and Service was a typical small town general welding and repair shop, with repairs being performed to automobiles, trucks, and farm equipment as well as to logging equipment, but the last mentioned comprised a major part of the business. La Tendresse was frequently called on to do welding in the woods to repair the tracks and other components of logging equipment, and, according to his son George, it was this in-woods repair work that made him realize tracked vehicles were too maintenance intensive. The machine La Tendresse designed, therefore, began with a truck chassis as its base. Working his ideas out with rough sketches and cardboard models and using scrap metal,<sup>170</sup> he completed the first working prototype in 1949 (See Figure 20 on page 64). After selling this first machine, he continued to refine the design, selling each prototype to local loggers as he completed them. The fifth machine La Tendresse built (See Figure 21 on page 65) was actually the first machine to include the extended reach feature, and as the world's first extended reach hydraulic fork loader, its design embodied several unique features.

---

<sup>168</sup> Anita Sikorsky, *Baragaland Bicentennial 1776-1976: A historical edition*. Baraga, MI: The Lumberjacks, 1976.

<sup>169</sup> "LeClaire purchases Dove Repair Shop," *L'Anse Sentinel* August 9, 1944:1.

<sup>170</sup> See Ferguson, p. 15, regarding the creative process and nonverbal thinking. Ferguson suggests that "the drawing becomes an active participant in the act of invention, sending back signals to the person making the drawing."

Prior to La Tendresse's development of this machine, which he called a Carry-Lift,<sup>171</sup> lift equipment had consisted of two types: what might be termed "conventional" forklifts, i.e., lifts which raised and lowered cargo vertically from below in which the carrier machine had to move forward or back for the load to be moved horizontally; and cranes which moved cargo in any direction while suspending it from above. La Tendresse's original design, which George La Tendresse reports was based on the actions of the human arm, both lifted cargo vertically and moved it forward or back horizontally without moving the carrier machine. The figures on the following pages show three early Carry-Lifts.

The lifting and pushing combination of the arms made the Cary-Lift<sup>172</sup> a revolutionary design. They enabled the equipment operator to safely load or offload the far side of docks, railroad cars, and stock piles. The early Cary-Lifts had a lifting capacity of 10,000 pounds at close lift and 6,000 pounds at the full extended reach (See Figure 22 on page 66). The machine featured heavy-duty four-wheel drive with hydraulic steering which allowed it to travel in mud, snow, and mill refuse piles, i.e., it wouldn't be slowed by debris such as wet sawdust, and it had an 8-speed transmission with a top speed of approximately 30 miles per hour. Early marketing efforts advertised that it was impossible to get the Cary-Lift stuck as its extended reach hydraulic forks enabled it to push itself out of any hole it might get bogged down in the mill yard.<sup>173</sup> In addition to the fork lift, a bucket could be attached for handling loose materials, e.g., sand and gravel, and a claw was available for picking up sawlogs and pulpwood.

The prototype machine, which was sold to the Emblad Brothers for their Skanee sawmill, was completed in 1949. Local loggers and sawmill operators were so favorably impressed with machine's performance that orders for more Cary-Lifts quickly followed. La Tendresse formed La

---

<sup>171</sup> One "r" would later be dropped from the name.

<sup>172</sup> Because the machine is now marketed as a Cary-Lift, with only one "r," this spelling will be used for the remainder of the thesis.

<sup>173</sup> See "Cary-lift yard type extended reach fork loader," *Pulp and Paper of Canada* 52(December 1951):118.



(Photo courtesy George La Tendresse.)

Figure 20. The first Carry-Lift.



(Photo courtesy George La Tendresse)

Figure 21. The first production model Cary-Lift.



(Photo courtesy George La Tendresse)

Figure 22. Muscle shot for advertising purposes.

Tendresse Manufacturing Company specifically to build the machines and by 1951 had sold a total of 13.<sup>174</sup>

With the start-up of the Korean conflict the United States military began looking for new cargo handling equipment and advertised for bids. According to George La Tendresse, his father had a friendly relationship with the local Congressman and was alerted by him to this potential opportunity. La Tendresse built a demonstration model from all new materials -- the first 13 machines had been assembled on a custom basis when orders were placed for them and had utilized salvage materials wherever possible to hold the costs down -- and the Army invited him to demonstrate this machine at Fort Belvoir, Virginia. The military immediately recognized its all-around utility and placed an order for twenty-five<sup>175</sup> Cary-Lifts, creating both an opportunity and a problem for La Tendresse.

The first thirteen machines had all been built on used truck chassis, which meant some machines were dual axle while others were single axle, (See Figure 23 on page 68) and utilized scrap iron and other salvaged materials. Each was completely custom-built for the customer purchasing it. The military required not only that each machine be identical with interchangeable parts, but, more importantly, that each be built from new materials. Military policy forbade the use of any salvage or rebuilt parts. The army contract presented a wonderful opportunity for a young company to expand, but La Tendresse lacked the necessary capital to comply with the terms specified. He needed to seek outside financing.

The history of any technological innovation is always dependent on contingencies and that of the Cary-Lift is certainly no exception, especially at this point. Several different versions of the same basic story are in circulation. According to Hubert Moberg, who has been with Pettibone-Michigan for forty years, since the early days when it was still La Tendresse Manufacturing Company, this financing was obtained through a fortuitous coincidence: a salesman for La Tendresse was travelling back to Michigan immediately after the demonstration at Fort

---

<sup>174</sup> Moberg.

<sup>175</sup> Hubert Moberg reports the number as being twenty-five where George La Tendresse remembers it as being thirty.



(Photo courtesy George La Tendresse)

**Figure 23.** The first Carry-Lift equipped with a swivel clam.



Belvoir and struck up a conversation with a salesman for Pettibone-Mulliken, a Chicago based corporation which manufactured heavy equipment. This conversation led to La Tendresse being invited to Chicago to negotiate an agreement under which Pettibone would provide financial support and marketing assistance.<sup>176</sup>

George La Tendresse remembers the incident slightly differently than Moberg tells it. According to George La Tendresse, the chairman for Pettibone-Mulliken was a native of Lake Linden, Michigan, and would travel by train to the Copper Country each autumn to admire the fall foliage colors. Philip La Tendresse happened to be on the same train travelling up to Houghton and struck up a conversation with him. That conversation eventually led to the agreement with Pettibone-Mulliken that resulted in the financing necessary to begin manufacturing Cary-Lifts in larger numbers in Baraga.

Pettibone-Mulliken was founded in 1880 as a company which specialized in railroad frogs, the sections of rail utilized for railroad switches (See Figure 24 on page 70). It had diversified over the years and by 1950 manufactured a variety of heavy machines for use in construction and other industries. The Cary-Lift presented Pettibone-Mulliken with an opportunity to exploit a new market, but the corporation had doubts about the wisdom of locating a manufacturing enterprise in an out-of-the-way location like Baraga, Michigan. One of the myths which has grown up around the story of Philip La Tendresse is that he sold his patent rights to Pettibone when they agreed to locate the plant in Upper Michigan.<sup>177</sup> George La Tendresse regards this as pure fiction. La Tendresse never relinquished patent control and retained all rights until the patents expired. Pettibone was indeed reluctant to locate in Baraga and only this patent control gave him the bargaining edge he needed to persuade them to consider such a remote location. Even then the agreement was not totally binding.

Pettibone agreed to allow the manufacture of Cary-Lifts in Baraga only under the condition that when the company ordered a unit the machine would be delivered within 30 days. This placed La Tendresse Manufacturing Company under constant deadline pressure but was not a problem for

---

<sup>176</sup> Moberg.

<sup>177</sup> Charles and Barbara Symon, *U-People* (Gladstone, MI: Ronjon Press, 1987), p. 44.

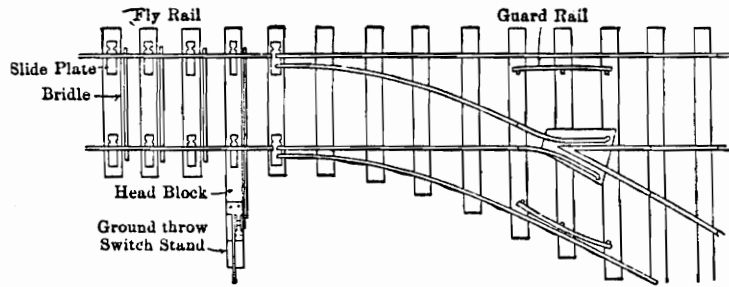

a STUB SWITCH

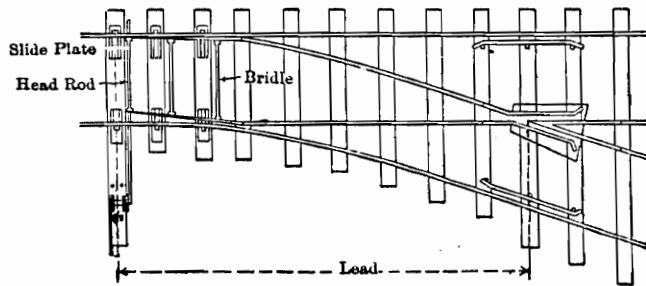

b SPLIT SWITCH

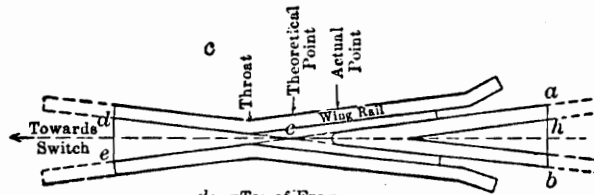

$de$  = Toe of Frog  
 $ab$  = Frog Heel  
 $acb$  = Frog Angle =  $dce$   
 $ch$  = Length of Frog  
 The Frog Number "n" =  $\frac{ch}{ab}$

— Two Forms of Turnouts used on Logging Railroads. a, the stub switch. b, the split switch. c, a standard frog.

(From Bryant, p. 326.)

Figure 24. A railroad frog.

six years, until 1957, when a fire destroyed the manufacturing facility in Baraga. When word of the fire reached Chicago, the corporate office immediately placed an order for a Cary-Lift, apparently seeing Baraga's misfortune as an opportunity to force a relocation of the manufacturing operation to a more urban setting. Instead of giving in to the inevitable, however, the workers and the community rallied, cooperating to assemble a Cary-Lift under adverse conditions, and delivered it on time. This demonstration of community support helped convince the corporation to remain in Baraga and they assisted in the construction of a new facility. When the new plant opened, it was under the name Pettibone-Michigan Corporation.

With the marketing power of a national corporation behind it, sales of the Pettibone Cary-Lift grew rapidly and reached into industries and locations worldwide. Although initially designed by La Tendresse for use in mill yards, its general utility as a loader meant the Cary-Lifts were used to move cargo and goods in every conceivable location. APA Technical Release 134 noted that the Cary-Lift had a number of interesting features that enhanced its utility in wood yards:

1. The hydraulic system may be relieved of the load weight by resting the load forks on the chassis frame.
2. When operating on uneven ground, a hydraulic leveling assembly permits perfect alignment of the fork tines with the load.
3. Loads can be extended or retracted a distance of four feet when the conventional attachment is used.
4. A four wheel drive and steer chassis permits operation over soft mucky areas at a fast rate of travel.

These same features applied to handling cargo of any sort, as Admiral Byrd recognized when he organized his 1955 expedition to the South Pole, Operation Deep Freeze. Byrd reportedly referred to the four Cary-Lifts accompanying him as "the work horses of the expedition."<sup>178</sup> What had begun as an innovation meant for use in one specialized industry had, through a combination of lucky accidents and good timing in addition to a design which lent itself to multiple uses, diffused rapidly into a variety of industrial and military settings. The next wave of innovation in logging would involve more specialized machinery.

---

<sup>178</sup> Barbara La Tendresse, personal interview, April 1988.

## Logging Tractors

The need for a true logging tractor had been expressed many times, beginning in the 1930s.<sup>179</sup> Crawler-tractors, although slowly gaining in popularity, were still outnumbered by horses in many regions. As late as 1951 McColl reported that in eastern Canada "the horse is still the prime mover for practically all wood moves less than two miles from the stump and competes with mechanical hauling methods at distances up to four miles from the stump."<sup>180</sup> Even later, in 1960, Thomas A. Walbridge would report that "Animal skidding is still the most common" method used in the Tennessee Valley region,<sup>181</sup> but this was no doubt attributable to the fact most of the logging operations Walbridge looked at were quite small. In 1951 McColl had concluded that the difficulties the terrain presented at the typical logging site made it unlikely an affordable mechanical prime mover would be developed in the near future. The development of a specialized heavy-duty chassis with both four-wheel drive transmission and steering for the Cary-Lift, however, foreshadowed the development of a four wheel drive logging tractor by only a few years.

In 1953 APA Technical Release 177 described the "J. T. Go Getter," a four wheel drive tractor marketed by John Thibodeau of Archer, Florida. Thibodeau's tractor was "designed specifically to operate under those logging conditions characteristic of the mucky and sandy swamp areas to be found throughout Florida and along the coast,"<sup>182</sup> but the APA report implied it was unlikely to go into mass production due to a lack of interest in developing a logging tractor on the part of any large firms. Two years later a follow-up report on the J. T. Go Getter indicated the machine had been considerably improved and could "get out of spots a crawler can not."<sup>183</sup> J. A. Holekamp, a

---

<sup>179</sup> Carson.

<sup>180</sup> B. J. McColl, "Problems in mechanical hauling from the stump," *Pulp and Paper Magazine of Canada* 52(January 1951):99+, p. 101.

<sup>181</sup> Thomas A. Walbridge jr., *The Design of Harvesting Systems and Machines for Use in Pulpwood Stands of the Tennessee Valley as Dictated by Intensive Forest Management* (University of Michigan: Ph.D. dissertation, 1960), p. 12.

<sup>182</sup> "The J. T. Go Getter: A Four Wheel Drive Logging Tractor," APA Technical Release 177, November 23, 1953.

<sup>183</sup> APA Technical Release 243, October 28, 1955.

logging engineer, optimistically hoped that "an ever-increasing number of rubber-mounted tractors will find their way into more and more Southern woods operations."<sup>184</sup>

Holekamp's wish was soon to be granted, at least in part,<sup>185</sup> as other rubber-mounted tractors followed Thibodeau's Go Getter in rapid succession. The Four Wheel Drive Auto Company of Clintonville, Wisconsin, sold the Blue Ox; Clark Equipment Company of Benton Harbor, Michigan, marketed the Michigan 75 Pulpwood Logger; Pettibone-Michigan introduced a Speed Skidder; the Garrett Enumclaw Company of Enumclaw, Washington, began selling the Garrett Tree Farmer; Wagner Tractor, Inc., manufactured the Wagner Loggermobile; and Timberland-Ellicott of Woodstock, Ontario, began producing Timberjack skidders, to name only a few. The entry of firms such as Clark into logging equipment development reflected the changing business environment. Established equipment manufacturers such as Caterpillar and Clark were venturing into an arena that had been the province of independent entrepreneurs and were beginning to develop specialized logging equipment rather than simply adapting their regular product line for woods work. By 1962, when Roger W. Drake of Franklin, Virginia, started marketing a logging tractor, the Franklin Logger, his machine was only one of many skidders available to loggers.

Drake, a native of Virginia's Southhampton County, began his business career at Cavalier Auto Service in Franklin in the 1950s. By the late 1950s Drake had purchased a building next door to the service station and opened Franklin Auto Parts. In addition to auto parts, Drake operated a repair shop and was an authorized dealer for Poulan chain saws and Pettibone machines. Pettibone had begun marketing the Speed Skidder, a fixed frame logging tractor,<sup>186</sup> in 1958, and loggers in the Tidewater area soon began to let Drake know what they viewed as its shortcomings. Drake, like La Tendresse, lacked a formal engineering education, but he did not view this as a liability. He

---

<sup>184</sup> APA Technical Release 243.

<sup>185</sup> For a variety of reasons too complex to deal with in this thesis, Southern loggers initially lagged behind the rest of the country and Canada in adopting mechanized logging methods. See Walbridge.

<sup>186</sup> The Speed Skidder now has an articulated frame.



(Photo courtesy Franklin Equipment Company)

Figure 25. Early model Franklin logging tractor.



(Photo courtesy Franklin Equipment Company)

Figure 26. Early model Franklin logging tractor.

proceeded to build a better machine, using spare parts from his auto supply business for assembling the prototypes.

Drake began working on his prototype machines in 1958 and actively solicited advice and comments from local loggers. Camp Manufacturing Company<sup>187</sup> helped test the machines and by 1962 Drake felt confident they were ready to go into production. He travelled to Illinois to pitch his idea for an improved logging tractor to a Chicago manufacturing firm. The firm apparently rejected his machine out of hand. Drake reportedly was told “no one in the world would ever buy it.”<sup>188</sup> In 1962 a logging tractor was not a novelty and any new skidder entering the market faced fierce competition. Drake refused to relinquish his ambition and instead turn to the local banks for financing. He established a manufacturing plant in a converted hangar at the Franklin Airport, and the first Franklin Logger to have a serial number rolled out in July 1962.<sup>189</sup> After selling the first few machines locally, in 1962 Drake began branching out and established relationships with sales agents nationally.<sup>190</sup>

The Franklin Logger contained no radically new innovations or unique engineering features. It incorporated ideas that, by 1962, were in general circulation among people in the logging industry. What made it a commercial success was the fact it was very much the product of suggestions from working loggers (See Figure 25 on page 74 and Figure 26 on page 75). Al Rollison, who has been with Franklin Equipment since the beginning, credits the close contact with customers over the years for the company’s continuing success. Franklin has never been outside the forest harvest market and has remained small enough to be responsive to this feedback. The first Franklin skidders did not have blades, but customer demand for one was so great that blades were quickly added. Other changes made within the first few years of production included:

- From drop center axles to planetary axles.

---

<sup>187</sup> Now known as Union Camp.

<sup>188</sup> R. E. Spears, “Manufacturer began in Franklin Airport hangar,” *The Tidewater News* July 16, 1987:1C.

<sup>189</sup> This first Franklin Logger is on display in front of the current Franklin Equipment Plant while the second unit resides in a logging museum in Lufkin, Texas.

<sup>190</sup> Materials provided by Franklin Equipment Company report these events all occurred in 1962, but an article in *The Tidewater News* states Drake’s trip to Chicago took place in 1960, with the development and testing period extending over two years before the first production model left the plant.



- From hydraulic winch to gear driven.
- From 200 Allison torque converter to 300.
- From small radiator to twice the capacity.
- From Continental engine to GM.

Franklin continues to manufacture only logging tractors, but a variety of options and modifications can meet individual customer requirements for anything from a cable skidder to a feller-buncher or forwarder.

Both the Pettibone Cary-Lift and the Franklin Skidder could serve as exemplars of successful innovations, however, neither one is problem-free. Their origins are very similar. Both grew out of the efforts of individual inventor-entrepreneurs who believed they had an idea for a machine that could perform better, more efficiently, or with fewer problems than any other machine currently in use. After the initial inventive activity, however, the innovations followed different paths. The Cary-Lift became a product marketed by a large, national corporation with a diverse product line and a bureaucratic structure. Some sources interviewed believed that corporate structure created problems in itself by placing restrictions on product development. Feedback from customers may have been ignored or taken too long to work its way through channels. Parts manufactured by one division, axles, for example, had to be used by other divisions even when those parts may not have been the best choice for the product. At the same time, the phenomenal sales success of the Cary-Lift in the 1950s and 1960s may have contributed to what is seen in retrospect as the increasing rigidity of the company. When a product's sales are steadily climbing, it can be difficult to envision the possibility of that trend ever reversing itself.

Franklin, on the other hand, began as a small, family-owned business and remains one to this day. The company carved out a niche in a specialized market and has chosen to remain small and flexible.

The internal approaches to manufacturing also differ. Pettibone-Michigan has always followed a job-shopping system. The majority of component parts are manufactured in machine shops and welding shops owned by subcontractors and then are assembled by Pettibone. In contrast, Franklin Equipment, although the company began by following a system very similar to Pettibone's, now

manufactures approximately eighty percent of the component parts, including axles, transmissions, and hydraulic cylinders, in-house. Franklin management believes that because this approach guarantees rigid adherence to quality control standards, it is worth it, despite the risk it entails that millions of dollars invested in capital equipment may stand idle if business is slow.

Logging tractors such as the Franklin skidder and loaders such as the Pettibone Cary-Lift are not the only examples of independent entrepreneur-inventors changing the practice of logging. Truck-mounted swing boom cable-sling loaders had been available since before the war but the first widely successful truck-mounted knuckle-boom hydraulic loaders did not appear until the 1950s. The Ray-Lind loader, Prentice loader, and Ramey loaders all emerged between 1949 and 1959, and all were the products of individuals, some within the logging community and some without, working in small shops to solve the multi-faceted problems facing the industry: how to increase production, decrease labor requirements, increase worker safety, and still produce a machine that was not beyond the financial reach of individual logging contractors.<sup>191</sup>

---

<sup>191</sup> David Knight, "Wood Tick Trail: A Grappling Version of 'Roots,'" *Timber Harvesting* September 1985:6-7+.

## Chapter Five: Conclusions

What preliminary conclusions about technological determinism, the diffusion of technological knowledge, and technological change can be safely drawn following this brief review of the history of technological innovation in industrial forestry in general and the development of two devices, the Pettibone Cary-Lift and the Franklin skidder, in particular? Several initial conclusions seem acceptable regarding how research in industrial forestry affects concerns in science and technology studies. These conclusions must be qualified as tentative, however, as the amount of recent research into the history of industrial forestry and timber harvesting is deplorably small. Further, the few works which have emerged in recent years have focused on the northern areas of the United States and Canada. Vast regions of the North American continent have been overlooked, such as the Southeastern states and the Mississippi valley. In addition, while the forest products industries find themselves embroiled in controversies ranging from the potential fate of disposable diapers to the impact of logging on spotted owl habitats, these controversies go unnoticed by the STS community. To say further research is needed in a multitude of areas is an understatement. Nonetheless, the following three preliminary conclusions seem justified.

A first conclusion is that the diffusion of technological knowledge occurs on multiple levels. It is true that technological knowledge may not be transmitted in as formal a manner as scientific knowledge, but it is also clear that in a literate society such as nineteenth and twentieth century

America the informal diffusion of knowledge consists of far more than one practitioner of a craft skill physically demonstrating that craft skill to another practitioner. The proliferation of periodicals such as *Popular Science*, the growth of vocational education, and the increasing awareness within a technological community of a need for improved communications all contributed to the rapid spread of new ideas and techniques in industrial forestry. This is an area which deserves extensive additional research.

Second, the history of technological innovation in industrial forestry and timber harvesting provides a potent argument against technological determinism. The development of the Cary-Lift was typical of technological innovation in forestry in many ways -- the role of individual entrepreneurship, for example -- but perhaps the most encouraging aspect is that it is also typical in the lack of a widespread uniform adaptation of the Cary-Lift to every setting. Despite its acknowledged success as a loader, every sawmill and lumberyard does not use a hydraulic loader, nor has its development meant that the technologies which preceded it have been displaced and lost. Industrial forestry appears to have become more diversified, not less, with the introduction of a wider variety of tools that have apparently broadened the range of choices available to practitioners in timber harvesting. Where Ellul and others have seen technology as transforming society, usually for the worse, through the "standardization and rationalization of economic and administrative life,"<sup>192</sup> mechanization in forest harvesting following World War II has had the opposite effect. Although commentators such as Jeremy Rifkin would have us believe we are "lost in a sea of perpetual technological transition. . . .surrounded [by] time-saving gadgetry, only to be overwhelmed by plans that cannot be carried out,"<sup>193</sup> this study of timber harvesting discovered harvesting was more rigid, more Taylorized,<sup>194</sup> in the 1920s and 1930s than it is now. Railroad logging, for example, achieved its most rational expression in the South in the early twentieth century, where the flat terrain in the eastern Carolinas and other coastal areas allowed tracks and

---

<sup>192</sup> Ellul, p. 11.

<sup>193</sup> Jeremy Rifkin, *Time Wars* (New York: Touchstone Books, 1987), p. 21.

<sup>194</sup> See Rifkin, pp.123-32, or David A. Hounshell, *From the American System to Mass Production, 1800-1932* (Baltimore, MD: The Johns Hopkins Press, 1987), pp. 249-53, for a description of F. W. Taylor and scientific management.

spurs to be laid out in perfect grids.<sup>195</sup> The division of labor, with each worker performing only a limited number of specialized tasks, e.g., swamping, would also seem to have lent itself to a Taylorized work environment.

Joseph C. Pitt has noted that many commentators tend to reify technology, to imbue it with characteristics that contribute to the notion of autonomous technology, but, as Pitt notes, this contradicts common sense.<sup>196</sup> If this notion of autonomous technology had any merit, then once a technology is in place, it should be extremely difficult to alter or remove. If this were true and the path forest harvesting was to follow in the twentieth century was in some way pre-determined by the technology being used, then logically it should have continued in a manner that did indeed bring the factory into the forest, with a commensurate loss of worker autonomy and an increasingly repressive environment. Writers such as Godwin and Koroleff indicate that professionals in industrial forestry in the 1930s and 1940s were consciously attempting to do just that, to organize the forest as an extension of the mill using the existing technology or improvements on the existing technology, but the historical record shows they did not succeed, at least not in the manner they had desired at the time.<sup>197</sup>

What has happened instead is that the technology which developed following World War II has, on one level of analysis, de-Taylorized the work environment and increased worker autonomy. This is not to say forest harvesting has become less rational overall; in many ways, the opposite is true. Harvesting tends more and more to be a "hot" operation, i.e., a continuous flow of material is processed as the timber harvested goes directly from the stump to the mill without being held in a cold deck for storage for later transport, and this entails high levels of efficiency. At the same time, however, while the harvesting operations have been made more efficient, they have also been rendered both more flexible and more humane. This appears to be an affirmation of the idea that ultimately technology is socially determined, not vice versa, as it was clearly social and economic

---

<sup>195</sup> See Brown, 1934, p. 172.

<sup>196</sup> Joseph C. Pitt, "The autonomy of technology," pp. 99-114 in Paul T. Durbin, ed., *Technology and Responsibility* (D. Reidel Publishing Co., 1987).

<sup>197</sup> Koroleff, 1937; Godwin.

factors which set the criteria that innovators in forest harvest technology were obliged to meet. The changing demographics of the labor pool,<sup>198</sup> for example, and, in recent years, an increasing concern with environmental issues such as water quality have heavily influenced the direction the new technological devices take. If the only goal to be met was to get the stems out of the forest as quickly and efficiently as possible, no doubt the range of available tools would be considerably narrower than it actually is, but even then the technology would have been determined by the goals society had set. It is important to remember, in timber harvesting as well as elsewhere, that in the end it is people who decide how the work should be organized and what tools will be used to accomplish it. We can fell a tree with an axe, a chainsaw, or a hydraulic shear, and the tree is felled not because any one of those tools exists but because some person wanted the tree cut. Prior to the most recent wave of innovations in timber harvesting, the choices in how to cut would have been narrower -- between a crosscut saw, perhaps, and an axe -- but it still would not have been the tool causing the tree to fall but rather the person wielding it. Technology provides options, not commands.

A final conclusion, one which is also tied directly to the issue of further research, is that in industrial forestry and timber harvesting the standard models of explanation for technological change that have been proffered to date clearly are inadequate. Whether the models are based on Kuhnian paradigms, e.g., Constant and Bijker, standard economic models, or systems analysis, they all lack balance.

Constant's notion of presumptive anomaly, for example, when applied in industrial forestry becomes meaningless. None of the innovations were developed as the result of theoretical or practical failures in the existing technology in the sense Constant employs these ideas. The existing technology had not failed, nor did it provide any theoretical grounds for assuming it ever would fail, when inventors began playing around with loaders following the war. That same technology -- e.g., jammers and cable systems -- in fact continues to be effectively used in many areas of logging to this day. The inventors who developed hydraulic loaders may have been prompted by a desire to

---

<sup>198</sup> See, for example, Radforth, pp.159-78.

develop a technology more appropriate to a specific setting than the technology currently in use, but the limits they saw in the existing technology involved not the technical artifact itself but rather economic and humane issues, social factors that Constant's model does not incorporate as potential anomalous elements.

Pinch and Bijker's social construction of technology (SCOT) theories also fail to provide a full picture of technological change. Bijker's concept of a technological frame, for example, seems overly simplistic. It may be true that individuals working in a certain discipline may overlook or reject ideas that are not perfectly congruent with their accustomed method of solving problems, but enough exceptions to this "rule" exist to render the idea itself rather weak. In forestry, for example, it is true that while some actors in the social network, particularly in management, remained locked into what might be called a mental technological stasis in that they envisioned the Taylorization of logging as occurring through the more efficient use of existing technology, it is equally true that a significant number of the more radical inventions and innovations came from within the existing technological frame of logging, e.g., railroad logging was suggested by a logger, not by locomotive manufacturers. Further, Bijker's model seems to be overlooking a phenomenon well known to economists, i.e., that a radical innovation capable of profoundly altering one technological frame may be a routine innovation in another, as Bijker does not really deal with the interactions between different technological frames.

In addition, to say that technological artifacts are socially constructed is not only an exercise in overstating the obvious. It also runs the risk of ignoring other factors which may either constrain or encourage technological change and thus turning the notion of social constructivism into an overly simplistic reductionism. Further, to attempt to restrict an analysis of technological change to one micro setting, i.e., one technological frame such as the bicycle industry, without considering how factors, particularly but not exclusively technical factors, in other frames may have affected that industry seems excessively narrow. Describing the developmental process of a technology as "an alternation of variation and selection"<sup>199</sup> and implying that it, i.e., the artifact, is solely the result

---

<sup>199</sup> Pinch, p. 28.

of the preferences of social groups overlooks other considerations, such as the availability of materials and the social setting as a whole. Pinch and Bijker do touch on this aspect briefly when they note that different social groups had different views of the bicycle -- some purchasers viewed it as a sporting device, others did not -- but this still seems to be focusing on choices in consumption while downplaying production. In short, they appear to be merely restating an old thesis, i.e., that invention is driven by social needs, while downplaying the fact that new inventions frequently appear that a need has to be created for, e.g., microwave ovens.

Although the systems model developed by Hughes appears to hold the most promise for evaluating technological change, it, too, has drawbacks. As articulated by Hughes, it seems to imply that a technological system inevitably progresses towards homogeneity as elements in the system become more standardized and interdependent. This could be the result of Hughes' choice of the electric utility industry for his study. While the electric utility industry may seem to be the archetypical technological system in many ways, in many others it is highly atypical. Most technological systems, if we understand a system to consist of the social, political, economic, and technical networks that a particular industry both influences and is influenced by, are not physically linked in the manner the electric utility industry is. Industrial forestry is a technological system comprised of producers and consumers, but the individual elements within that system retain far more autonomy than the individual elements within the electrical utility system. One of the ironies, in fact, of invention and innovation in logging in the years following World War II is that the system evidences far more diversity within its components than it did prior to the war.

Technological change has not meant an inevitable drift towards standardization but has instead provided individuals within the system with a greater range of choices.

Further, Hughes draws heavily upon analogies to military campaigns and compares the growth of a technological system with the advancement of a military front. The image generated is thus one which implies that problems arise external to the existing system, i.e., as the system grows it encounters new difficulties. This fails to account for changes within systems which have been in place for extended periods of time. This type of analysis may work well for explaining changes in the development of a system, especially in the case of systems such as that of the electric utility



industry, because it is easy to see how the system responds as it encounters impediments to its growth. In the case of other technological systems, however, the "reverse salients" may not be external to the system or problems which hinder its growth but may instead be internal difficulties which threaten the system's continued stability or survival. For this reason, rather than conceiving of a technological system as Hughes does, i.e., as continually expanding its boundaries outward, I believe it would be more fruitful to consider a technological system as an ecological system with homeostatic mechanisms which strive to maintain an internal equilibrium. Because a system strives to maintain this internal balance, changes in the system are more likely to occur when conditions either outside the system or within it are altered in a way that disturbs that balance. For example, in the case of timber harvesting, a major impetus for change was the shrinking labor pool following World War II. While labor turnover had always been high, it was not until the decade following the war that the problem reached crisis proportions. What had been viewed as an unavoidable nuisance for many years<sup>200</sup> was no longer acceptable. When the weaklings were, as Holbrook put it, weeded out, their replacements were increasingly difficult to find. The dynamics within the system changed, and as the idea of replacing labor with mechanized equipment became more palatable a more favorable climate for innovation was created. Rather than requiring new equipment for performing new tasks, as in the electric utility industry when companies became interconnected in regional power grids and automatic control systems became necessary,<sup>201</sup> the forest products industries required new equipment to perform existing tasks, e.g., mechanized loaders, because the men who had once loaded pulpwood manually were no longer available. The burst of innovative activity which began in the late 1940s was a manifestation of homeostasis within industrial forestry and timber harvesting which occurred in response to a threat to the stability of that particular technological system.

If technological systems are considered in this way, i.e., as ecological systems with homeostatic mechanisms, it becomes easier to explain why some proposed innovations enjoy rapid adoption and diffusion while others are rejected. In addition, an ecological model could allow for the

---

<sup>200</sup> Holbrook, pp. Holbrook, 1937, p. 21; Hutula; Mihelich.

<sup>201</sup> See, for example, Constant, p. 50.

consideration of salient factors other than purely economic and technical ones, i.e., it would attempt to consider the biological and cultural influences in addition to more easily quantifiable factors. Moreover, I would also argue that in an ecological technological system, a truly successful innovation is not merely one which enjoys wide adoption, but is also one which contributes to internal equilibrium of that system. This, however, poses a variety of interesting questions -- e.g., how do we differentiate between those innovations which contribute to the health of a system and those which have the long-term effect of damaging it? -- but these are questions which become increasingly compelling as the cost of the effects of past ill-conceived or hastily implemented technologies become more apparent to society as a whole. Perhaps additional research in science and technology studies can help to find a way for technological systems and industrialized societies to achieve a healthy, dynamic equilibrium, i.e., homeostasis, without those systems either degenerating into simple stasis and stagnation or having to confront a crisis before implementing change.

## **Appendix A. Pettibone Super 30 Cary-Lift 1989**

# PETTIBONE

# SUPER 30 CARY-LIFT®

- 5' (1.52m) forward reach at any height
- High lift — 14'-0" (4.27m)
- Balanced weight distribution
- Power shift transmission
- Torque converter
- Planetary axles — 4 wheel drive
- 4 wheel air powered brakes — mechanical parking brakes
- Hydraulic power steering

MODEL 304-A

the all-weather all-purpose loader  
30,000 LB. (13,608 kg) LIFT  
AND CARRY CAPACITY

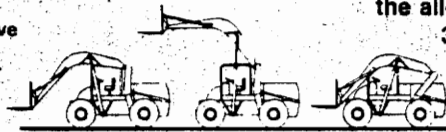

REACHES

LIFTS

CARRIES

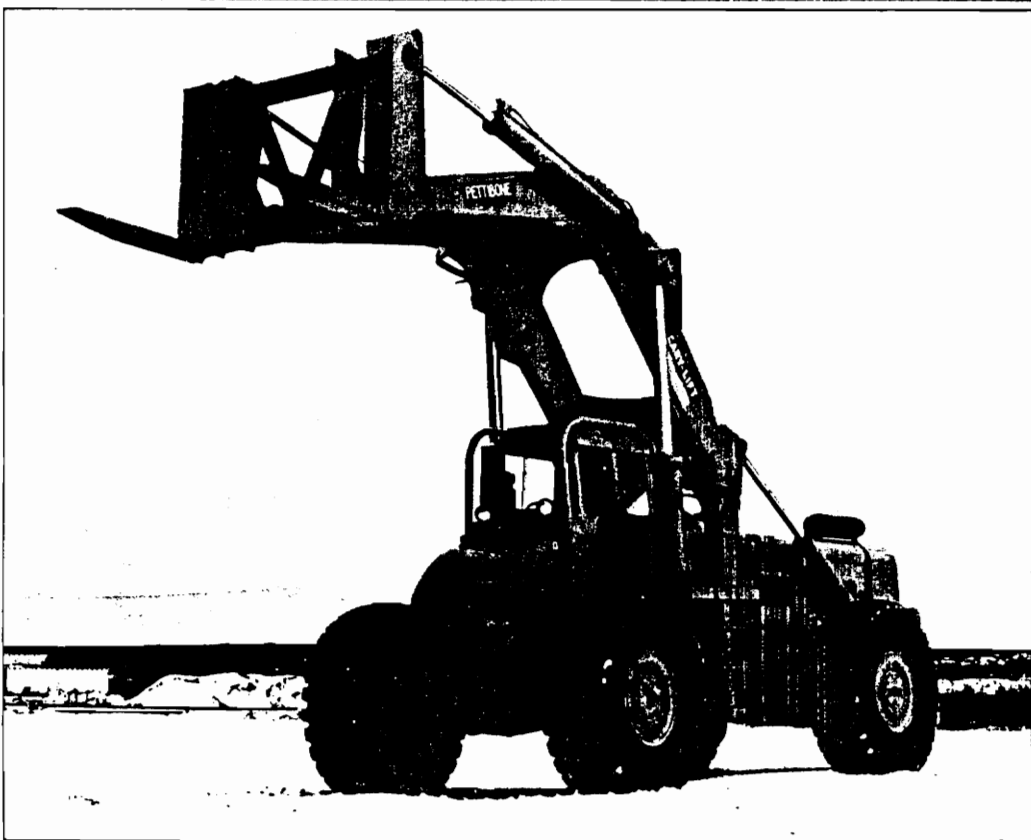

PM 617-D

**PETTIBONE****SUPER 30  
CARY-LIFT****MODEL 304-A****SPECIFICATIONS****OVERALL MEASUREMENTS**

Height overall — maximum raised position	18'-6" (5.64m)
Height overall carrying position	12'-3" (3.73m)
Width overall	10'-0" (3.05m)
Length overall at maximum reach	35'-3" (10.74m)
Length overall at carrying position	29'-7" (9.02m)
Wheel base	14'-0" (4.27m)
Minimum ground clearance (Lowest point)	19½" (49.53cm)
Total weight (approx.)	59,000 lbs. (26,762kg)
Weight on front axle	24,500 lbs. (11,113kg)
Weight on rear axle	34,500 lbs. (15,649kg)

**DETAILS**

Maximum working load — load retracted @ 36" (914mm) load center	30,000 lbs. (13,608kg)
Maximum working load — load extended @ 36" (914mm) load center	15,000 lbs. (6,804kg)
Spread of forks (outside edges)	84" (2.13m)
Length of forks	60" (1.52m)
Maximum lifting height — forks level	14'-0" (4.27m)

**REACH FROM FRONT OF FRAME TO TIP OF FORKS****WITH LIFT ARMS EXTENDED:**

Forks parallel to ground at 8'-7" (2.62m) height	11'-2" (3.40m)
Forks parallel to ground at 14'-6" (4.42m) height	9'-10" (3.00m)

**REACH FROM FRONT OF FRAME TO TIP OF FORKS****WITH LIFT ARMS RETRACTED:**

Forks parallel to ground at maximum height	5'-6" (1.68m)
--	---------------

**POWER TRAIN****ENGINE**

Make	GMC Diesel
Model No.	6-71 N65
Maximum rated brake horsepower	230
Piston displacement	425.6 cu. in. (6.976cc)
Bore and stroke	4¼" x 5" (10.80cm x 12.70cm)
Number of cylinders	6
Electrical system	12 volts
Fuel tank capacity	100 gal. (378.5 L)

**TRANSMISSION**

Clark model 4421

**TORQUE CONVERTER**

Clark C5502

**GEAR RATIO**

1st	4.14
2nd	2.28
3rd	1.31
4th	0.71

**TRAVEL SPEEDS**

	Forward and Reverse
1st	3.1 mph (5.0 km/h)
2nd	5.6 mph (9.0 km/h)
3rd	9.8 mph (15.8 km/h)
4th	18 mph (29.0 km/h)

**AXLES**

Rockwell Planetary Drive — 25.74 to 1 ratio

**WHEELS**

15.00 x 25 — rim	Interchangeable
------------------	-----------------

**TIRES**

21:00 x 25 — 28 PR tubeless	Interchangeable
29.5 x 25 — 22 PR tubeless	Interchangeable (optional) at extra cost

**TREAD**

105" (2.67m)

**TURNING RADIUS**

Outside of tires Approx. 27' (8.23m)

**BRAKES**

4 wheel air — Mechanical parking brake

**HYDRAULIC PUMPS**

Main, gear type	85 gpm (321.7 Lpm) @ 2300 rpm
Auxiliary, gear type	56 gpm (212.0 Lpm) @ 2300 rpm
Steering	14 gpm (53.0 Lpm) controlled flow

**HYDRAULIC CYLINDERS**

Function	Bore	Stroke
Lift	8" (20.32cm)	55" (139.7cm)
Reach	6" (15.24cm)	48¾" (123.8cm)
Fork	6" (15.24cm)	73" (185.4cm)
Steering	5" (12.7cm)	5¼" (13.3cm)

**STANDARD EQUIPMENT**

All hydraulic steering; 2-wheel, 4-wheel and oblique; 4 wheel air brakes; mechanical parking brake; adjustable upholstered seat; foot throttle; alternator; starter; voltage regulator; two batteries; hour meter; volt meter; engine oil pressure gauge; engine water temperature gauge; converter oil pressure gauge; converter oil temperature gauge; heavy duty air cleaner; engine oil filter; transmission oil filter; muffler; hard chrome plated cylinder shafts; anti-freeze; load holding valves; roller thrust slides; electric horn; rear view mirror; back up alarm; seat belt; power assist hydraulic controls.

**OPTIONAL EQUIPMENT**

BV-71 Diesel Engine; all weather cab; heater; defroster; wiper; air conditioner; lights (front and rear).

**PETTIBONE**

PETTIBONE CORPORATION  
P.O. BOX 6227  
DULUTH, MN 55806  
(715) 382-5694  
TELEX 29 4428

Pettibone Corporation reserves the right to change specifications and prices without notice in order to follow its policy of constantly striving to manufacture a better product without incurring any liability to provide these new features on any units previously manufactured.

**SOLD AND SERVICED BY**

PRINTED IN U.S.A.

# **Appendix A. Franklin 105 Grapple Skidder M-28 1990**

# 105 GRAPPLE SKIDDER M-28

ENGINE:	STANDARD	OPTIONAL
Manufacturer	Detroit Diesel	Cummins
Model/Cyls	3-5JN50/3 cyls.	4BT3.9/4cyls.
Max. HP	97 @ 2650 RPM (72kw)	100 @ 2500 RPM (75kw)
Flywheel HP	85 @ 2650 RPM (63kw)	88 @ 2500 RPM (66kw)
Governed RPM	2650 RPM	2500 RPM
Max. Torque	@1800 RPM-205ft lbs(28kgm)	@1700 RPM-260ft lbs(36kgm)
Bore & Stroke	3.975"x4.5" (101mmx114mm)	4.02"x4.72" (102mmx120mm)
Displacement	159 cu. in (2.6 liters)	239 cu. in. (3.9 liters)

**POWER TRAIN:**  
 Transmission.....Franklin F4-200, 4 speed powershift  
 Torque Converter..... Rockford 10.1" (259mm)  
 Axles..... Franklin F-185; Planetary, heavy duty  
 Differentials..... No-spin, front & rear  
 Brakes-Service..... Enclosed, multi-disc, wet brake  
 Parking..... Enclosed, multi-disc, wet brake, automatic

**OPERATIONAL**  
 Frame Articulation Angle.....+38  
 Frame Oscillation Angle.....+15

**TRAVEL SPEED (mph)**

	1st	2nd	3rd	4th
Forward	0-1.16	0-3.56	0-9.15	0-15.13
Reverse	0-1.16	0-5.56		

**HYDRAULIC SYSTEM**  
 Hydraulic Quick Steering  
 Steering Pump (gear type) 20.5 GPM @ 2650 RPM  
 Winch, Blade and Grapple  
 Pump 24 GPM @ 2650 RPM  
 Hydraulic Reservoir Capacity 25 Gals.  
 Filtration: 10 Micron Return Line By-pass Filter and Suction  
 Strainer  
 Steering Cylinder Two Double Acting Cylinders with  
 3" x 16" Stroke & 1-1/2" Rod  
 Blade Cylinder Two Double Acting Cylinders with  
 3" x 16" Stroke & 1-1/2" Rod  
 Grapple - (74" Openings)  
 Lift Cylinders Two Double Acting Cylinders with  
 3-1/2" x 16" Stroke & 1-1/2" Rod  
 Bucket Cylinders Two Double Acting Cylinders with  
 4" x 12" Stroke & 2-1/2" Rod

**STANDARD EQUIPMENT:**  
 Two Stage Dry Air Cleaner  
 12 Volt Electrical System  
 Full Belly Fans & Hinged Bomb Bay Doors  
 KOPS and FOPS Cab  
 10 lb. Fire Extinguisher  
 Tapered Roller Bearings in Center Section  
 Tapered Roller Bearings in Grapple Head  
 Swing Retarders  
 Limb Deflectors  
 Wrapped Muffler  
 Cab Fan  
 Suspension Seat  
 Shock Mounted Engine and Radiator  
 Cab Doors  
 Seat Belt  
 44 Gallon Fuel Tank  
 74 inch Grapple Opening(5.2 SqFt)

**WINCH:**  
 Make..... Franklin M-32  
 Max. Line Pull..... 27,000 (12,247 kg)  
 Max Line Speed..... 127 FPM (69m/min)  
 Drum Capacity..... 1/2"-270' (13mm-82m)  
 5/8"-176' (16mm-54m)

Single Lever Controlled, Hydraulically Activated

**TIRES:** 18.4 x 26 LS2 Steel Reinforced, Standard  
 Optional: 18.4 x 34, 23.1 x 26, 28L x 26, 67/34.00 x 26

**WEIGHT:**  
 With Standard Equipment..... 18,340 (8,321 kg)

**OPTIONS:** Lights, Heater, Enclosed Cab,  
 Cummins 4BT3.9 Engine, F-205 Axles

All Specifications Are Subject To Change

05/89

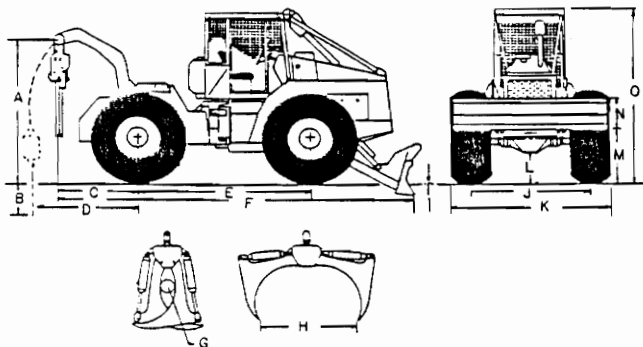

w/18.4 x 26 Tires and F-185 Axles

A- 96"-2438.4mm	I- 97"-2463.8mm
B- 26"-660.4mm	J- 18"-457.2mm
C- 50"-1270mm	K- 43"-1092.2mm
D- 71"-1803.4mm	L- 20"-508mm
E- 108"-2743.2mm	M- 110"-2794mm
F- 235"-5969mm	N- 74"-1879.6mm
G- 12"-304.8mm	O- 5.5"-139.7mm
H- 79"-2006.6mm	

For More Information, See Your Local Franklin Dealer or Write  
 Franklin Equipment Company, Post Office Box 697, Franklin,  
 Virginia 23851





# 105 PM-28

FRANKLIN EQUIPMENT COMPANY, P.O. Box 697, Franklin, VA 23851, (804) 562-6111



## Appendix B. Glossary

202

**Arch:** A supporting device mounted on or towed behind a skidding vehicle. Used to lift one end of a log to reduce sliding resistance and/or transfer weight of the log to the skidder unit.

**Articulated:** With reference to a machine, such as a wheeled skidder, means hinged at the center.

**Buck:** To saw felled trees into shorter lengths.

**Bucker.:** One who saws felled trees into the desired lengths, i.e., logs, bolts and sticks.

**Bucking:** The process of dividing (normally sawing) the merchantable stem into shorter lengths.

**Cant hook:** A tool like a peavey, having a toe ring and lip at the end instead of a pike. See also "peavey."

---

<sup>202</sup> Definitions are from W. S. Bromley, *Pulpwood Production* (Danville, IL: The Interstate Printers & Publishers, Inc., 1969), and *Handbook for Eastern Timber Harvesting* (Broomall, PA: United States Department of Agriculture, 1979).

**Choker:** A short length of wire rope that forms a noose around the end of log to be skidded and is attached to the skidding vehicle or to the butt rigging in wire rope logging systems.

**Cold deck:** Logs piled on a landing for future loading when skidding units are finished with the area.

**Cord:** A unit of measurement of stacked wood. A standard pulpwood cord contains 128 cubic feet within its outside surfaces.

**Deck:** (1)A pile of logs on a landing. (2)Area or platform on which wood is placed. See "landing."

**Donkey:** In wire rope logging, a portable engine mounted on a sled and equipped with winches and drum. May be designated by the special use to which it is put, such as yarding, skidding, or loading.

**Fairlead:** In logging, a device containing sheaves or rollers, used to guide wire rope onto a drum.

**Faller:** One who fells trees. Synonyms include cutter, feller, flathead, sawyer, and stumper.

**Grapple:** (1)A device at the working end of a line or boom and used to pick up and hold the load. (2) Two small iron dogs joined by a short chain and used to couple logs end to end when skidding.

**Haulback line:** A line used in wire rope logging systems to return the mainline, butt rigging and chokers to where the logs to be skidded will be hooked.

**Hauling:** The act of transporting pulpwood sticks, multiple stick lengths or tree lengths from the loading site in the woods to a mill, mechanized woodyard or unmechanized rail siding. Hauling begins when the primary hauling vehicle leaves the loading site and ends when it returns.

**Highgrading:** A logging operation where only the best trees in the stand are cut. Synonym: "creaming."

**Highlead logging:** A wire rope logging system where a mechanical spar or spar tree is used to raise the mainline block as high as possible so as to provide some lift to the ends of the logs being yarded.

**Jammer:** A wire rope yarding and/or loading machine having one or more drums and mounted on skids, wheels or trucks (usually on an old truck frame).

**Landing:** An area where logs are brought by skidding or forwarding units for subsequent loading and hauling. Synonyms include bank, brow, deck, log dump, rollway.

**Limbing:** The process of removing limbs from a felled tree.

**Loader:** Machine or person used to load pulpwood into a carrier.

**Loading:** The process of placing pulpwood, in the form of bolts, sticks, multiple stick lengths, logs or tree lengths on a hauling vehicle.

**Log:** A tree segment suitable for subsequent processing into lumber, pulpwood, or other wood products.

**Logger:** One engaged in the production of logs or pulpwood.

**Mainline:** (1) In yarding, the line used to bring in the logs to the landing. (2) On a skidder, the winchline.

**Peavey:** A stout lever 5 to 7 feet long, fitted with a socket and spike and a curved hook that works on a bolt, used in handling logs. See also "cant hook."

**Pulpwood:** Wood cut or prepared primarily for manufacture into wood pulp, for subsequent manufacture into paper, fiber board, or other products, depending largely on the species cut and the pulping process.

**Rigging:** The wire rope, blocks and hooks used in wire rope systems of logging.

**Skidder:** A machine used to skid logs or trees to a landing.

**Skyline:** A cable suspended between spars, serving as a track for an overhead carriage, used in cable yarding.

**Sulky:** A towed logging arch mounted on wheels.

**Swamping:** Clearing an area of brush, limbs and other obstructions for a working area.

**Swamper:** One who swamps an area.

**Top load:** A member of the loading crew who place and positions logs or bolts on the load.

## Bibliography

Agassi, Joseph. "Technology as both art and science." *Research in Philosophy and Technology Volume 6* 1983:55-63.

Agassi, Joseph. *Technology: Philosophical and Social Aspects* Dordrecht: D. Reidel Publishing Company, 1985.

"Again -- trouble in lumber camps." *Business Week* October 19, 1940:26+ .

Allen, Shirley Walter. *An Introduction to American Forestry*. New York: McGraw-Hill Book Company, 1950.

American Pulpwood Association Technical Releases, 1947-1965. American Pulpwood Association, Washington, D.C.

Barella, Richard, and Thomas Wright, eds. *An Interpretive History of Industrial Arts: The Interrelationship of Society, Education, and Industrial Arts*. American Council on Industrial Arts Education: 1981.

Barnett, LeRoy. "Taming the Tahquamenon." *Michigan History* 74.1(1990):21-3.

Baum, Arthur W. "Revolution in the pines." *Saturday Evening Post* 217(July 22, 1944):22-3+ .

Bell, Daniel. "Resolving the contradictions of modernity and modernism." *Society* 27.3(March/April 1990):43-50.

Bennett, Charles Alpheus. *History of Manual and Industrial Education*. The Manual Arts Press, 1937.

Bernhardt, Debra. "Ballad of a lumber strike." *Michigan History* 62.1(1982):38-43.

"The big dirt diggers." *Fortune* January 1945:130-41.

Bijker, Wiebe E. "The social construction of Bakelite: toward a theory of invention." Pp. 159-87 in *The Social Construction of Technological Systems*, eds. Wiebe E. Bijker, Thomas P. Hughes, and Trevor Pinch. Cambridge, MA: MIT Press, 1989.

Boone, Andrew R. "Flexible power in the woods." *Scientific American* 160(May 1939):304-5.

Borgmann, Albert. *Technology and the Character of Contemporary Life*. Chicago: University of Chicago Press, 1987.

Bromley, W. S. *Pulpwood Production*. Danville, IL: Interstate Publications, 1969.

Brown, Nelson Courtland. *Logging -- Principles and Practices in the United States*. New York: John Wiley & Sons, 1934.

Brown, Nelson Courtland. *Logging: The Principles and Methods of Harvesting Timber in the United States and Canada*. New York: John Wiley & Sons, 1949.

Bruce, Robert V. "The American style of invention." *American Patent Law Association Bulletin* June 1976.

"Bulldozer blade controlled by hydraulic cylinder." *Engineering News-Record* April 2, 1931:579.

Callon, Michel. "The state and technical innovation: a case study of the electric vehicle in France." *Research Policy* 9(1980):358-76.

Carson, W. J. "New uses of tractors on logging operations." *Pulp and Paper Magazine of Canada* 38(September 1937):696-98.

"Cary-lift yard type extended reach fork loader." *Pulp and Paper Magazine of Canada* 52(December 1951):118.

Chandler, Alfred D., jr. *The Visible Hand: The Managerial Revolution in American Business*. Cambridge, MA: The Belknap Press, 1977.

Collet, M. H. "Pulpwood production tools." *Paper Trade Journal* November 1945:1203-6+.

Colville, Leslie L. "Development and use of Forest Service slashbuncher teeth." *Journal of Forestry* 44(February 1946):89-91.

Conlin, Joseph. "Old boy, did you get enough of pie? A social history of food in logging camps." *Journal of Forest History* October 1979:164-85.

Connor, Mary Roddis. *A Century with Connor Lumber: Connor Forest Industries, 1872-1972*. Stevens Point, WI: Worzalla Publishing Co., 1972.

Constant, Edward. *The Origins of the Turbojet Revolution*. Baltimore, MD: The Johns Hopkins University Press, 1980.

Conway, Steve. *Logging Practices: Principles of Timber Harvesting Systems*. Miller Freeman Publications, 1976.

Cozzens, Susan E. "Book review: *The Social Construction of Technological Systems: New Directions in the Sociology and History of Technology*," *Technology and Culture* 30.3(1989):705-07.

Cutcliffe, Stephen. "The emergence of STS as an academic field." *Research in Philosophy and Technology* 9(1989):287-301.

Daft, Richard L. *Organization Theory and Design*, second edition. St. Paul, MN: West Publishing Company, 1986.

Downey, Gary L. "Ideology and the Clamshell identity: organizational dilemmas in the anti-nuclear power movement." *Social Problems* 33(1986):357-73.

Downey, Gary L., Arthur Donovan, and Timothy J. Elliott. "The invisible engineer: how engineering ceased to be a problem in science and technology studies." Manuscript, 1989.

Drake, R. Wilson. Personal interview. February 9, 1990.

Ebner, Adelbert. "Forest transportation problems." *Pulp and Paper Magazine of Canada* 37(November 1936):704-12.

Ellul, Jacques. *The Technological Society*. New York: Vintage Books, 1964.

Elster, Jon. *Explaining Technological Change*. Cambridge: Cambridge University Press, 1985.

Evans, Rupert N. *Foundations of Vocational Education*. Columbus, OH: Charles E. Merrill Publishing, 1971.

Ferguson, Eugene S. "The nature of play and the intellect." Manuscript prepared for the Annual Meeting of the American Anthropological Association, Washington, D.C., 1980.

Fernow, Bernard E. *A Brief History of Forestry in Europe, the United States and Other Countries*, third revised edition. Toronto: University Press, 1913.

Franklin Equipment Company Records. Franklin Equipment Company, Franklin, Virginia.

Gilfillan, S. C. *The Sociology of Invention*. Cambridge, MA: MIT Press, 1970.

Girouard, Jacques. "Mechanized logging at Forestville." *Pulp and Paper Magazine of Canada* 49(June 1948):111-14.

Godwin, Gordon. "Problems of mechanized logging." *Journal of Forestry* 45(August 1947):549-54.

Gorz, Andre. "On the class character of science and scientists." Pp. 59-71 in Hilary Rose and Steven Rose, eds., *The Political Economy of Science*. London: MacMillan, 1976.

Gray, R. B. *The Agricultural Tractor, 1855-1950*. St. Joseph, MI: American Society of Agricultural Engineers, 1974.

Grosser, Christian E. "Hydraulic leakage can be controlled." *Machine Design* 14(August 1942):70-3.

Hay, Duncan. *Hydroelectric Development in the United States, 1880-1940*. Manuscript prepared for the Edison Electric Institute, 1989.

Hickman, Nollie W. *Mississippi Harvest*. Montgomery, AL: The Paragon Press, 1962.

Hirsh, Richard F. *Technology and Transformation in the American Utility Industry*. Cambridge: Cambridge University Press, 1989.

- Holbrook, Stewart H. *Holy Old Mackinaw: A Natural History of the American Lumberjack*. New York: MacMillan, 1953.
- Holbrook, Stewart H. "So long, Jigger Jones." *The Saturday Evening Post* July 8, 1934:22+ .
- Hooker, Leland. *Woods Safety Handbook*. Houghton, MI: Forest Products Research Division, Michigan College of Mines, 1950.
- Hughes, Thomas P. "The evolution of large technological systems." Pp. 51-82 in *The Social Construction of Technological Systems*, eds. Wiebe E. Bijker, Thomas P. Hughes, and Trevor Pinch. Cambridge, MA: MIT Press, 1989.
- Hughes, Thomas P. *Networks of Power*. Baltimore, MD: Johns Hopkins Press, 1983.
- Hutula, William. Personal interview. July 20, 1988.
- "Hydraulically-operated farm machinery: the Ferguson farm tractor." *The Engineer* August 28, 1936:206.
- "Ingenious loaders built from scrap." *Popular Science* 143(December 1943):200-01.
- "Iron arms move a cord of wood in 90 seconds." *Popular Mechanics* May 1945:57.
- Jamison, Andrew. "Technology's theorists: conceptions of innovation in relation to science and technology policy." *Technology and Culture* 30.3(1989):505-33.
- Jarvie, I. C. "The social character of technological problems: comments on Skolimowski's paper." Pp. 50-53 in Carl Mitcham and Robert Mackey, eds., *Philosophy and Technology*. New York: The Free Press, 1972.
- Kelly, John W. "Design simplicity prerequisite of hydraulic control standardization." *Aero Digest* 41(December 1942):211+ .
- Kline, Benjamin F. G., jr. *Dinkies, Dams, and Sawdust: The Logging Railroads of West Central Pennsylvania*. Williamsport, PA: Lycoming Press, 1975.
- Knight, David. "Wood Tick Trail: A Grappling Version of 'Roots.'" *Timber Harvesting* September 1985:6-7+ .
- Koroleff, A. "Mechanization of logging." *Pulp and Paper Magazine of Canada* 38(October 1937):757-58.
- Koroleff, A. *Pulpwood Hauling with Horse and Sleigh: Efficiency of Technique*. Pulp and Paper Research Institute of Canada, 1947.
- Kuhn, Thomas S. *The Structure of Scientific Revolutions*, second edition. Chicago, IL: University of Chicago Press, 1970.
- Lahti, Leonard. Personal interview. August 9, 1972.
- L'Anse Sentinel*. L'Anse, Michigan.
- LaTendresse, Barbara. Personal interview. April 22, 1988.
- LaTendresse, George. Personal interview. April 22, 1988.



LaTendresse, George. Telephone interview. February 17, 1990.

Latour, Bruno, and Steve Woolgar. *Laboratory Life: The Social Construction of Scientific Facts*. Princeton, NJ: Princeton University Press, 1986.

"Literal log jam." *Business Week* August 15, 1942:64.

Lodge, John E. "Amazing machines speed work of modern lumberjacks." *Popular Science* 127(September 1935):25-8+.

"Logging goes modern." *Popular Mechanics* 72(1939):17-24.

Lucia, Ellis. "A lesson from nature: Joe Cox and his revolutionary saw chain." *Journal of Forest History* 25.3(1981):158-65.

"Lumber strike." *Business Week* May 18, 1935:10.

MacDuff, S. I., and G. A. Goepfrich. "Hydraulic machine gun chargers." *Aero Digest* 42(February 1943):243-44+.

MacKenzie, Donald E., and Elwood R. Maunder. "Logging equipment development in the West." *Journal of Forest History* 16.3(1972):30-33.

MacPherson, C. B. "Democratic theory: ontology and technology." Pp. 161-70 in Carl Mitcham and Robert Mackey, eds., *Philosophy and Technology*. New York: The Free Press, 1972.

"Marathon instructs vets in mechanized logging." *Pulp and Paper Magazine of Canada* 47(March 1946):71-6.

Markle, Gerald E., and Stanley S. Robin. "Biotechnology and the social reconstruction of molecular biology." Pp. 111-21 in Daryl E. Chubin and Ellen W. Chu, eds., *Science Off the Pedestal*. Belmont, CA: Wadsworth Publishing Company, 1989.

Marx, Harry J. "Aircraft experience aids industrial hydraulics." *Machine Design* 15(September/October 1943):91-5, 100-04.

Maybee, Roland H. *Michigan's White Pine Era 1840-1900*. Lansing, MI: Michigan State Historical Society, 1976.

McCull, B. J. "Developments in mechanical logging in 1951." *Pulp and Paper of Canada* 52(May 1951):140+.

McCull, B. J. "The Logger's Dream." *Pulp and Paper Magazine of Canada* 50(January 1949):132.

McCull, B. J. "Problems in mechanical handling from the stump." *Pulp and Paper of Canada* 52(January 1951):99+.

McCull, B. J. "Recent developments in mechanical logging." *Pulp and Paper of Canada* 51(April 1950):128+.

McCull, B. J. "Woodlands mechanization." *Pulp and Paper Magazine of Canada* 49(September 1948):125-6.

- McKelvey, John P. "Science and technology: the driver and the driven." *Technology Review* 88(January 1985):38-47.
- McLellan, David, ed. *Karl Marx: Selected Writings*. Oxford: Oxford University Press, 1988.
- McNally, J. A. "Logging tools are greatly improved." *Pulp and Paper Magazine of Canada* 43(July 1942):627-28.
- Mihelich, John. Personal interview. August 3, 1987..
- Mitcham, Carl, and Robert Mackey. "Technology as a philosophical problem." Pp. 1-30 in Carl Mitcham and Robert Mackey, eds., *Philosophy and Technology*. New York: The Free Press, 1972.
- Moberg, Hubert. Personal interview. August 10, 1988.
- Moberg, Hubert. Telephone interview. December 12, 1989.
- "Mobile camp built on flat-cars." *Engineering News-Record* 78(June 14, 1917):570.
- Nelkin, Dorothy, and Michael S. Brown. *Workers at Risk: Voices from the Workplace*. Chicago: University of Chicago Press, 1984.
- Nelligan, John Emmett. *A White Pine Empire: The Life of a Lumberman*. St. Cloud, MN: North Star Press, 1969.
- Newton-White, E. "Trouble in the woods." *Canadian Forum* 14(July 1934):383-4.
- "1/2-cubic yard hydraulic loading shovel." *Engineering* September 30, 1938:403.
- Parayil, Govindan. *Conceptualizing Technological Change*. Ph.D. dissertation at Virginia Polytechnic Institute and State University, Blacksburg, VA, 1990.
- Parker, Clyde. Personal interview. February 9, 1990.
- "The Parnall power-operated gun turret." *Engineering* 154(November 6, 1942):366-67, 370.
- Pepler, W. A. E., and B. J. McColl. "The status of mechanization." *Pulp and Paper Magazine of Canada* 50(May 1949):154+.
- Pettibone-Michigan Company Records. Pettibone-Michigan, Baraga, Michigan.
- Pinch, Trevor J., and Wiebe E. Bijker. "The social construction of facts and artifacts: or how the sociology of science and the sociology of technology might benefit each other." Pp. 17-50 in Wiebe E. Bijker, Thomas P. Hughes, and Trevor J. Pinch, eds., *The Social Construction of Technological Systems: New Directions in the Sociology and History of Technology*. Cambridge, MA: The MIT Press, 1989.
- Pinchot, Gifford. *Breaking New Ground*. New York: Harcourt, Brace and Company, 1947.
- Pitt, Joseph C. "The autonomy of technology." Pp. 99-114 in *Technology and Responsibility*. D. Reidel Publishing Company, 1987.
- Pitt, Joseph C. "The epistemological engine." *Philosophica* 32(1983):77-95.
- Radforth, Ian. *Bushworkers and Bosses: Logging in Northern Ontario 1900-1980*. Toronto: University of Toronto Press, 1987.

- "Railway coaches equipped as camp buildings for lumber crew." *Engineering Record* 75(January 13, 1917):67.
- Rajala, Richard. "Bill and the boss: labor protest, technological change, and the transformation of the west coast logging camp, 1890-1930." *Journal of Forest History* October 1989:168-79.
- Rifkin, Jeremy. *Time Wars*. New York: Touchstone Books, 1987.
- Rolison, Al. Personal interview. February 9, 1990.
- Rose, Peter I., Penina M. Glazer, and Myron Glazer. *Sociology*. Englewood Cliffs, NJ: Prentice-Hall, Inc., 1984.
- Rosegger, Gerhard. *The Economics of Production and Innovation: An Industrial Perspective*, second edition. Oxford: Pergamon Press, 1986.
- Rosenberg, Nathan. *Perspectives on Technology*. Cambridge: Cambridge University Press, 1976.
- Schindler, E. R. "How mechanical efficiency is being increased in the southern pine industry." *Journal of Forestry* 48(October 1950):705-9.
- Schmookler, Jacob. *Invention and Economic Growth*. Cambridge, MA: Harvard University Press, 1966.
- Sikorsky, Anita, ed. *Baragaland Bicentennial 1776-1976: A historical edition*. Baraga, MI: The Lumberjack, 1976.
- Skolimowski, Henryk. "The structure of thinking in technology." Pp. 42-49 in Carl Mitcham and Robert Mackey, eds., *Philosophy and Technology*. New York: The Free Press, 1972.
- Staudenmeier, John M. *Technology's Storytellers: Reweaving the Human Fabric*. Cambridge, MA: The MIT Press, 1989.
- Stenzel, George, Thomas A. Walbridge jr., and T. Kenneth Pearce. *Logging and Pulpwood Production*, second edition. New York: John Wiley & Sons, 1985.
- Suddaby, H. "Tractor built from old car parts without machining." *Popular Mechanics* 71(1939):790-95, 953-55.
- Symon, Charles and Barbara. *U-People*. Gladstone, MI: Ronjon Press, 1987.
- Taber, Thomas T., III. *Ghost Lumber Towns of Central Pennsylvania: Luquin, Masters, Ricketts, Grays Run*. Williamsport, PA: Lycoming Printing Co., 1970.
- Taber, Thomas T., III. *Tanbark, Alcohol, and Lumber*. Williamsport, PA: Lycoming Press, 1974.
- Thienpoint, Russell F. *Tract Size and Timber Harvesting System Relationships in the Southeast*. Master's thesis, Virginia Polytechnic Institute and State University, 1976.
- "Thus Paul Bunyan's sons gamble with death." *Literary Digest* November 21, 1934:28+.
- The Tidewater News*. Franklin, Virginia.
- Town, H. C. "Recent developments in the use of hydraulic power." *Institute of Mechanical Engineers Journal and Proceedings* 143(May 1940):Proceedings 129-41.

- Twiss, Brian C. *Managing Technological Innovation*, second edition. London: Longman, 1982.
- United States Department of Agriculture. *After A Hundred Years: The Yearbook of Agriculture, 1962*. Washington, D.C.: The United States Government Printing Office, 1962.
- United States Department of Agriculture. *Handbook for Eastern Timber Harvesting*. Broomall, PA: Forest Service, 1979.
- "Unrest in woods." *Business Week* December 13, 1941:74-6.
- Vail, David. "How to tell the forest from the trees." *Technology in Society* 11(1989):347-76.
- Van Tassel, Alfred. *Mechanization in the Lumber Industry: A Study of Technology in Relation to Resources and Employment Opportunity*. Philadelphia, PA: Work Projects Administration, 1940.
- Walbridge, Thomas A., jr. *The Design of Harvesting Systems and Machines for Use in Pulpwood Stands of the Tennessee Valley as Dictated by Intensive Forest Management*. Ph.D. dissertation, University of Michigan, 1960.
- "Walkout shrinks." *Business Week* June 3, 1944:107+ .
- "Wanted: loggers -- crucial shortage of lumber caused by manpower pinch." *Newsweek* 21(May 10, 1942):57-8.
- Weaver, E. W. "Mechanical load handling equipment." *Welding Journal* 22(August 1943):619-23.
- "Welco self-contained hydraulic generator." *American Machinist* June 7, 1933:385.
- White, Dale. *Gifford Pinchot: The Man Who Saved the Forests*. New York: Julian Messner, Inc., 1957.

## Vita

The author was born May 3, 1948, at Marquette, Michigan. A nontraditional student, she worked at a variety of interesting albeit low-paying jobs, including sales analyst at the largest Ford dealership in southern California, dash waxer at an Octopus ("Many hands to serve you") Carwash in Madison, Wisconsin, and acting sports editor for the *Ironwood Daily Globe*, before beginning her college education in January 1985. She received an Associate of Science degree from Gogebic Community College in Ironwood, Michigan, in May 1986, and a Bachelor of Science in Social Sciences from Michigan Technological University, Houghton, Michigan, in May 1988. She graduated magna cum laude and was honored as the outstanding graduate in Social Sciences at Michigan Tech in 1988, and is a member of Phi Kappa Phi honor society. In 1989 she served as the historian for the Historic American Engineering Record's Skagit Hydroelectric Project recording project. Her publications include "Sawdust in the Wind: A Brief History of Tama Siding," forthcoming in *Michigan History* in 1990, and "Nobody Knows Who We Are: A Participant-Observer Study of an Agricultural Engineering Seminar" in *Proceedings of the 17th Annual AKD Sociological Research Symposium*.

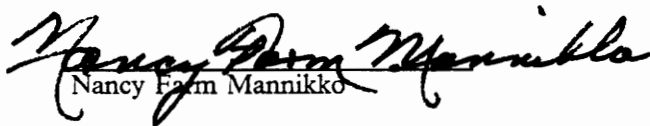

Nancy Farm Mannikko