

A Public Bath in Alexandria, Virginia

A Public Bath in Alexandria, Virginia
: Water, Body, and Architecture

Dongkeon (DK) Kim

ABSTRACT

This thesis investigation and design project were driven by the desire to develop and understand how body relates nature through tectonic objects. I explore how body reacts to different thermal and moisture condition from architectural elements in order to examine the relationship between body and objects. Any physical form will be meaningless if it cannot transmit the presence of nature and cosmos by way of image and totality of experience into the human habitation with concrete objects. Furthermore, when the body perceives the cosmos through tangible objects then those objects become significant life form. Through the process of experience on different types of water treatment, it reveals the way of transforming and communicating between invisible sense in body and tangible substance in cosmos. The bathhouse design is a record of the process that exposes the connections between human perception and universal materiality through tectonic objects.



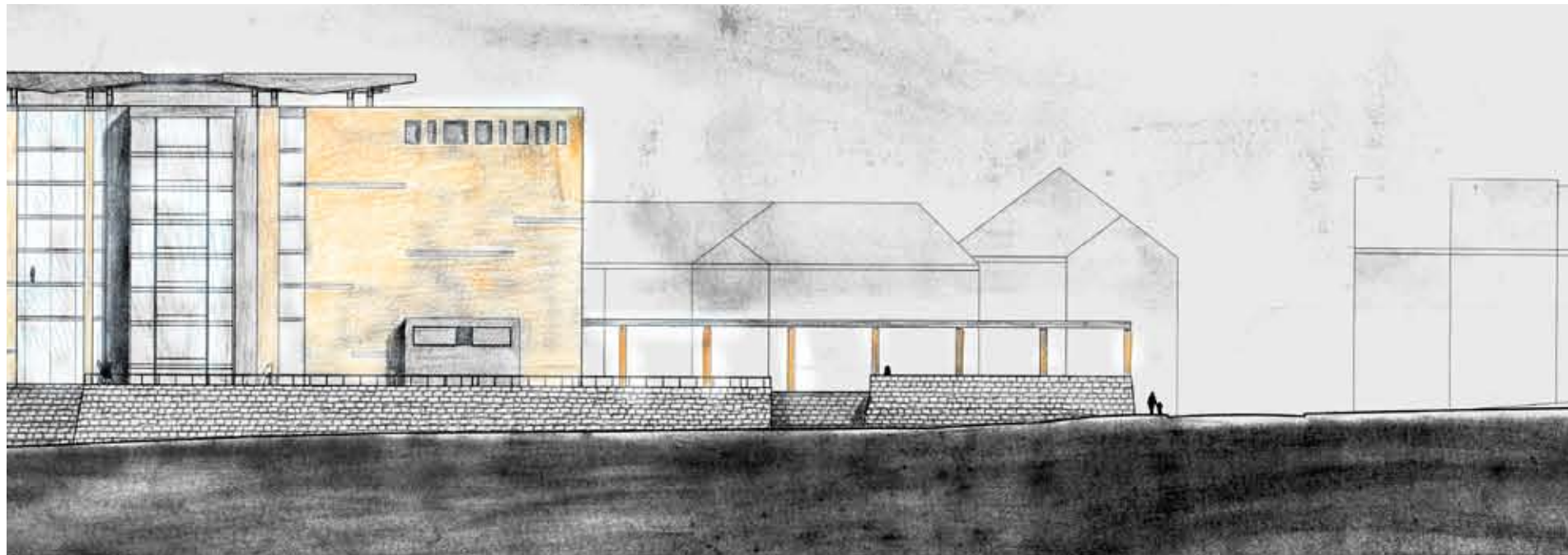

Thesis is submitted to the faculty of the Virginia Polytechnic Institute and State University in partial fulfillment of the requirements for the degree of Master of Architecture in Architecture and Urban Studies.

Committee Chairman, Jaan Holt

Committee Member, Paul Emmons

Committee Member, Susan Piedmont-Palladino

May 23, 2007
Washington Alexandria Architecture Center
Alexandria, Virginia

Keywords: Water, Body, Connection, Cosmos, columns,
Walls, Skin, Detail, River, Rain, Storm water

CONTENTS

- i Abstract
- iv Dedication
- 01 City and River
- 03 Site
- 05 River Water
- 07 Rain Water
- 09 Storm Water
- 11 Body and Water
- 13 The Beginnings
- 21 Main Creation
- 40 Photo Credit, Acknowledgement, and Bibliography

contents

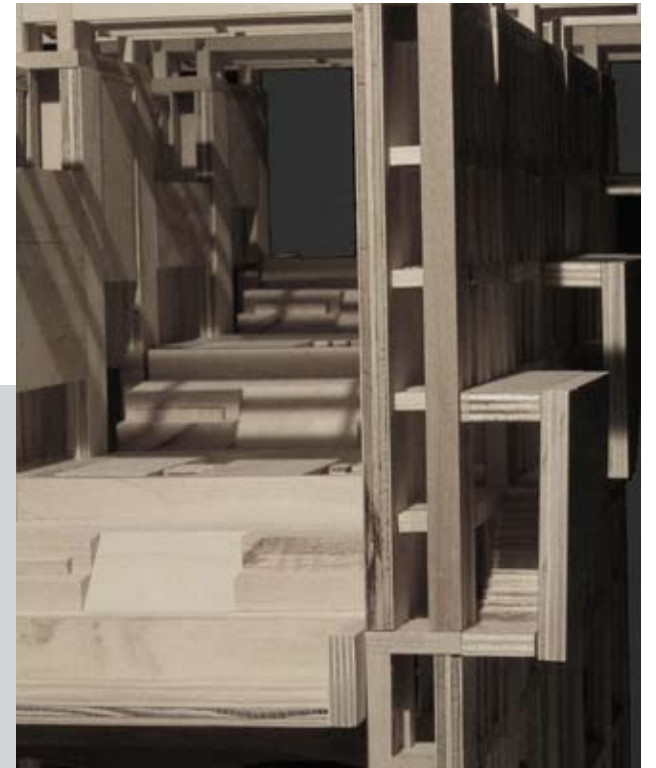



A Public Bath in Alexandria, Virginia

DEDICATION

I would like to dedicate this book to my Angela, best friend and lovely wife. Without her patience, understanding and love I could not finish my journey to explore and experience architecture. I am very grateful to Jaan Holt, Paul Emmons and Susan Piedmont-Palladino for their strong encouragement, guidance, and inspiration.

dedication



CITY AND RIVER

Alexandria was founded in 1749 and named so in honor of its original owner, John Alexander. Alexandria is located six miles south from Washington D.C. across from the west bank of the Potomac River and nine miles north of Mount Vernon. Old Town Alexandria is the heart and center of Alexandria. According to Wikipedia.com, “In 1790, Alexandria was included in the area chosen by George Washington to become the District of Columbia. By 1846, the District of Columbia reduced in size to exclude the portion south of the Potomac River. At the time of the Revolution, Alexandria was one of the principal colonial trading centers and ports. In modern times Old Town is chiefly known for its historic town houses, art galleries, antique shops and restaurants. The city encompasses 15.75 square miles at an average elevation of 30 feet above sea level.”¹



The Potomac River flows through the District of Columbia and reaches to Chesapeake Bay passing by historical landmarks of the region. Potomac River becomes part of the project as the city element which creates a way of experiencing nature. The project generates city landscape elements such as walls, terraces, stoops, entrances, and pergolas. These objects are accomplished by not only urban scale of graphic abstraction but also concretized architectural design elements which reveal the metaphysical meaning of the city context.



1. wikipedia the free encyclopedia
<http://en.wikipedia.org/wiki/Alexandria,_Virginia>
(8 August 2007).

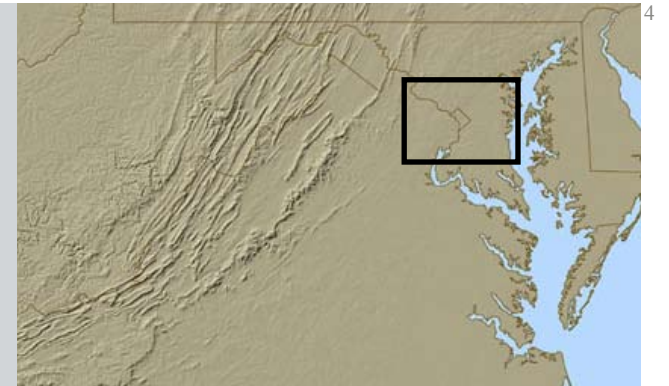



city and river

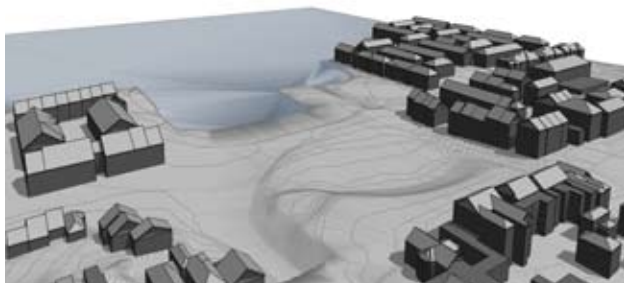

SITE

The Site is located in Alexandria, Virginia alongside the Potomac River. At the intersection of Union Street and Gibbon Street, there is an empty lot presently used as a dog park next to a town home complex. The City of Alexandria recently installed storm water systems along Gibbon Street which discharge collected water at the side of Union Street to the river. The shape of the site is changeable according to the ebb and flow of the tide. One block north from the site is the Wilkes tunnel, abandoned since the O&A railroad shut down the Orange line. The storm water inlet divides the lot into two parts. The first part is the north side 100' x 374' long and narrow condition lot which has direct river water contact through old concrete retaining walls that remain from the old marina. The second part is 260' x 170' dimension, very slightly sloped to the river bottom. The Potomac hill park encompasses the whole site with its arms from the west hill side to the waterfront. Most view line is opened to the Washington Monument in north, the naval laboratory across the river in east, and the Woodrow Wilson Bridge in south. The Potomac water flows from the north in Fairfax Stone, West Virginia, to the south reaching the Chesapeake Bay. Site context is newly developed town home complex 3 to 4 story height conventional light wood framing with brick veneer structure.

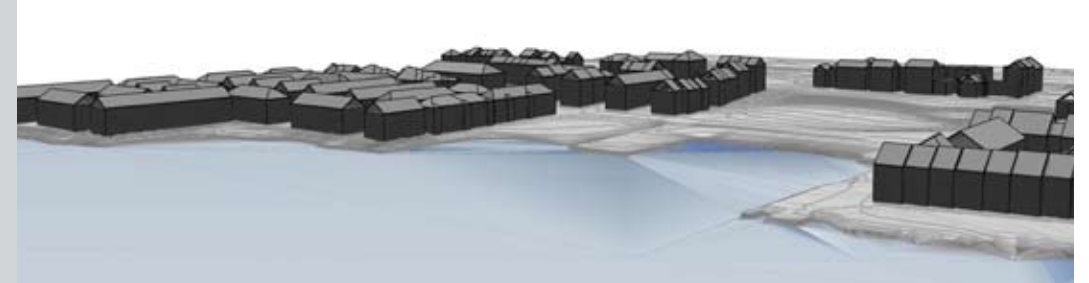

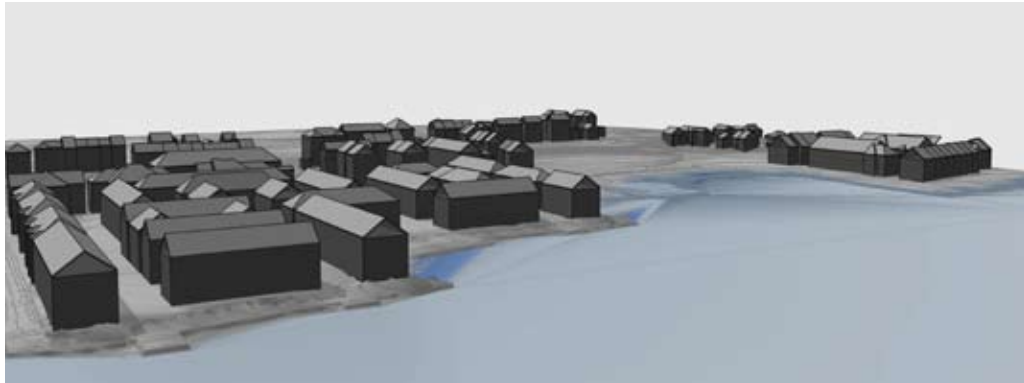

site

river water

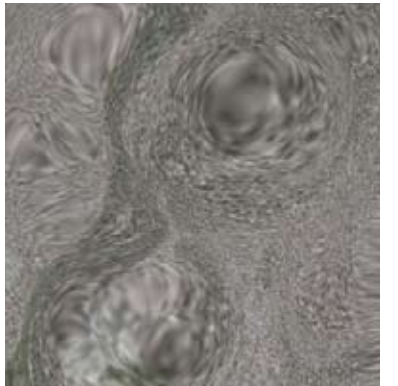
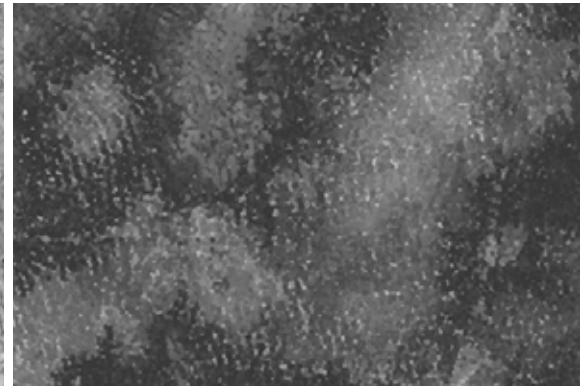
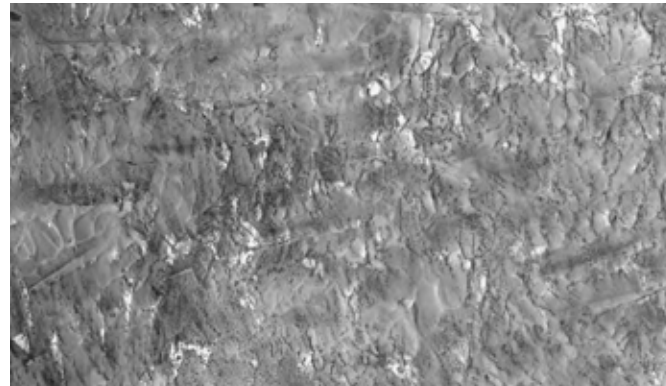
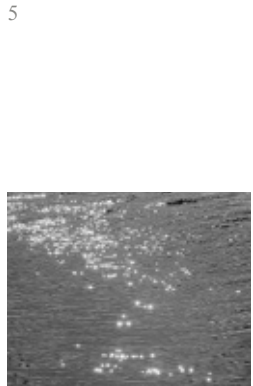
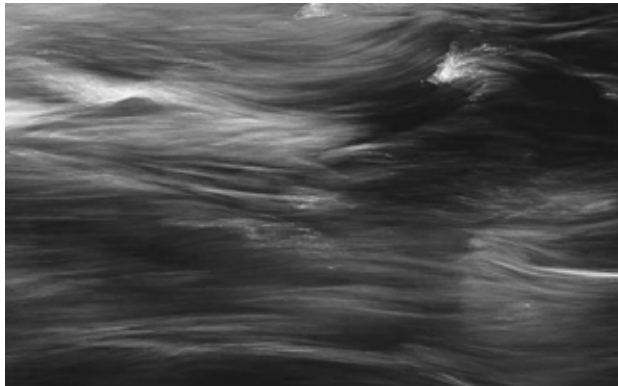

5

All numbered photo images copyright © 2007 Adobe Stock Photos

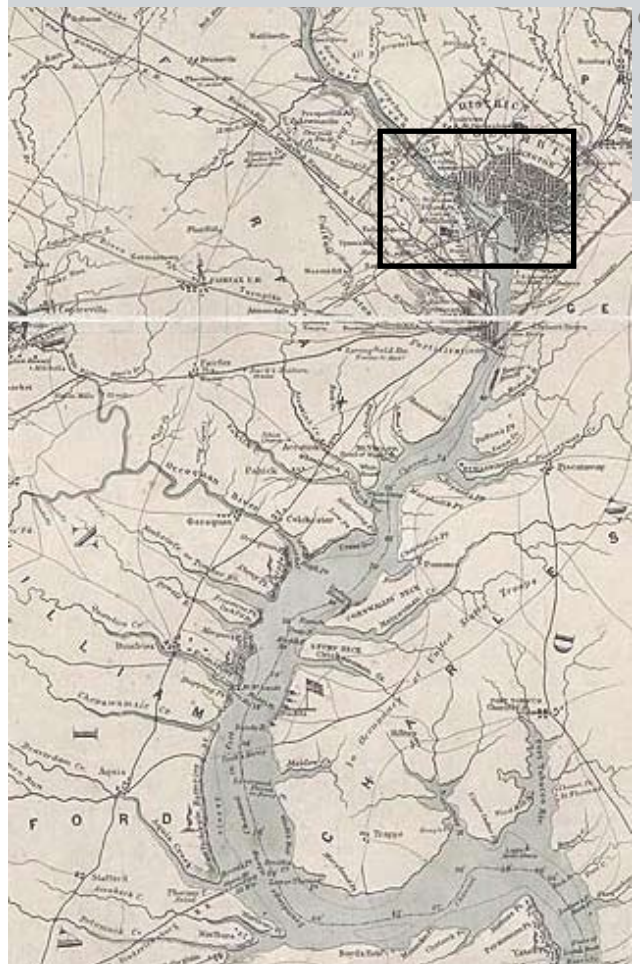

RIVER WATER

Vitruvius explains about water, “Finally, without the influence of moisture, living creatures will be bloodless..... Thus, to take examples, suppose there is a deficiency of breath in the body, the air, to which is assigned the function of making up the deficiency, performs that service....Then again, the fruits of the earth, satisfying our desires with a more than sufficient store of food stuffs..... Finally, water, not merely supplying drink but filling an infinite number of practical needs.”² River water is a vein to make adjacent territory vital and vivid just like blood stream in bodies. Vitruvius reveals not only physical effects and advantages of river water on human life, which are a source of drinking water, transportation, power of machinery, and disposing of waste water but also essential relationship between human life and nature. River water usually flows through topographical containers such as channels, stream beds, and banks. And those become a very important town situating element and representation of imperative liquid flow that contains various biological activities such as birth, grow, and death. Diversity of river water flowing images are demonstrating optical notion and artistic representation of river water in this project to express water as the most important element for creating and sustaining life in architecture.

² Vitruvius. *Ten Books On Architecture*, Trans. Morris Hicky Morgan (New York:Dover Publication, 1960), 225.

rain water

7



8



9



10



11

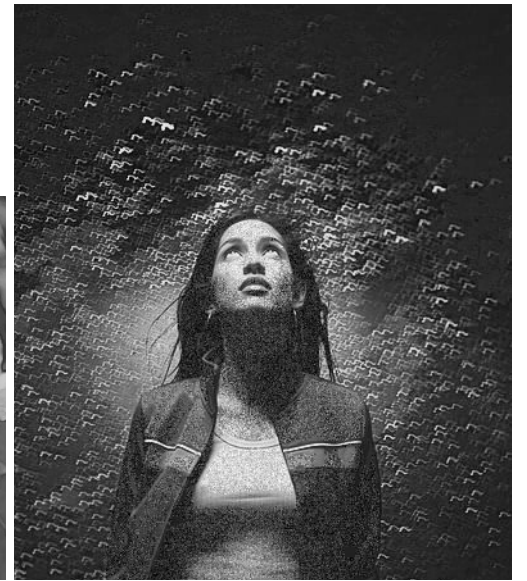

All numbered photo images copyright © 2007 Adobe Stock Photos

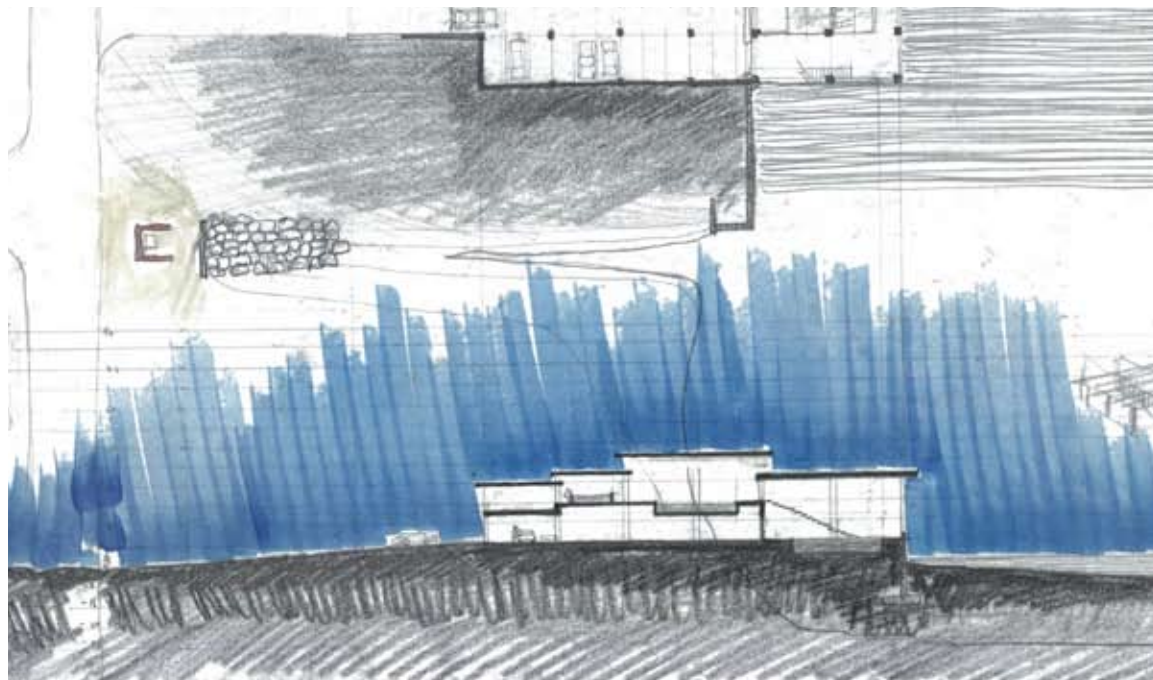

A Public Bath in Alexandria, Virginia



2. Vitruvius. Ten Books On Architecture, Trans. Morris Hicky Morgan (New York:Dover Publication, 1960), 225

RAIN WATER

Rain metaphorically has a sad and negative connotation in some cultures, even though it is very refreshing function in human environment. Rainwater is the main theme in this project connecting nature and human reaction. Two strong connecting factors are cleansing city and treating body. The city is deeply cleaned by rainwater and the rainwater is filtered through the water treatment process in this project. Collected rainwater is used to treat human bodies. The bodies became part of natural circulation with an artificial treatment process. In other words, the bodies turn into immense natural circulation through architectural filtering elements. Vitruvius mentioned rainwater, “Rainwater has, therefore, more wholesome qualities, because it is drawn from the lightest and most delicately pure parts of all the springs, and then, after being filtered through the agitated air, it is liquefied by storms and so returns to the earth.... for the reason that the vapor which is set in motion at sunrise in the morning, leaves the earth, and drives the air before it through the heaven in whatever direction it inclines.”³ Rainwater is an intermediation that creates relationship between heaven and earth. Gaseous body which is heaven meets solid matter which is earth through liquid form as mediator. The nature is circulating in many different forms. Rainwater is one of most important elements that compose universe.

3. Vitruvius. Ten Books On Architecture, Trans. Morris Hicky Morgan. (New York:Dover Publication, 1960), 229.

storm water

12

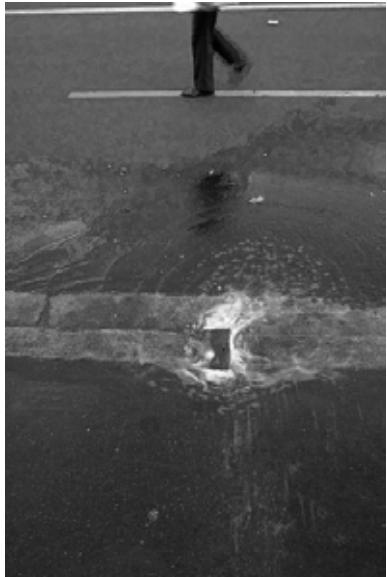

13



14

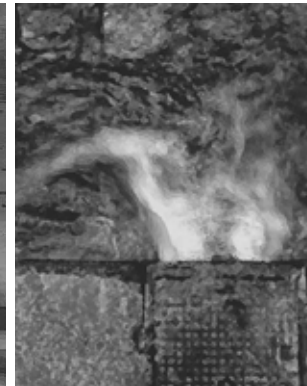

15



All numbered photo images copyright © 2007 Adobe Stock Photos

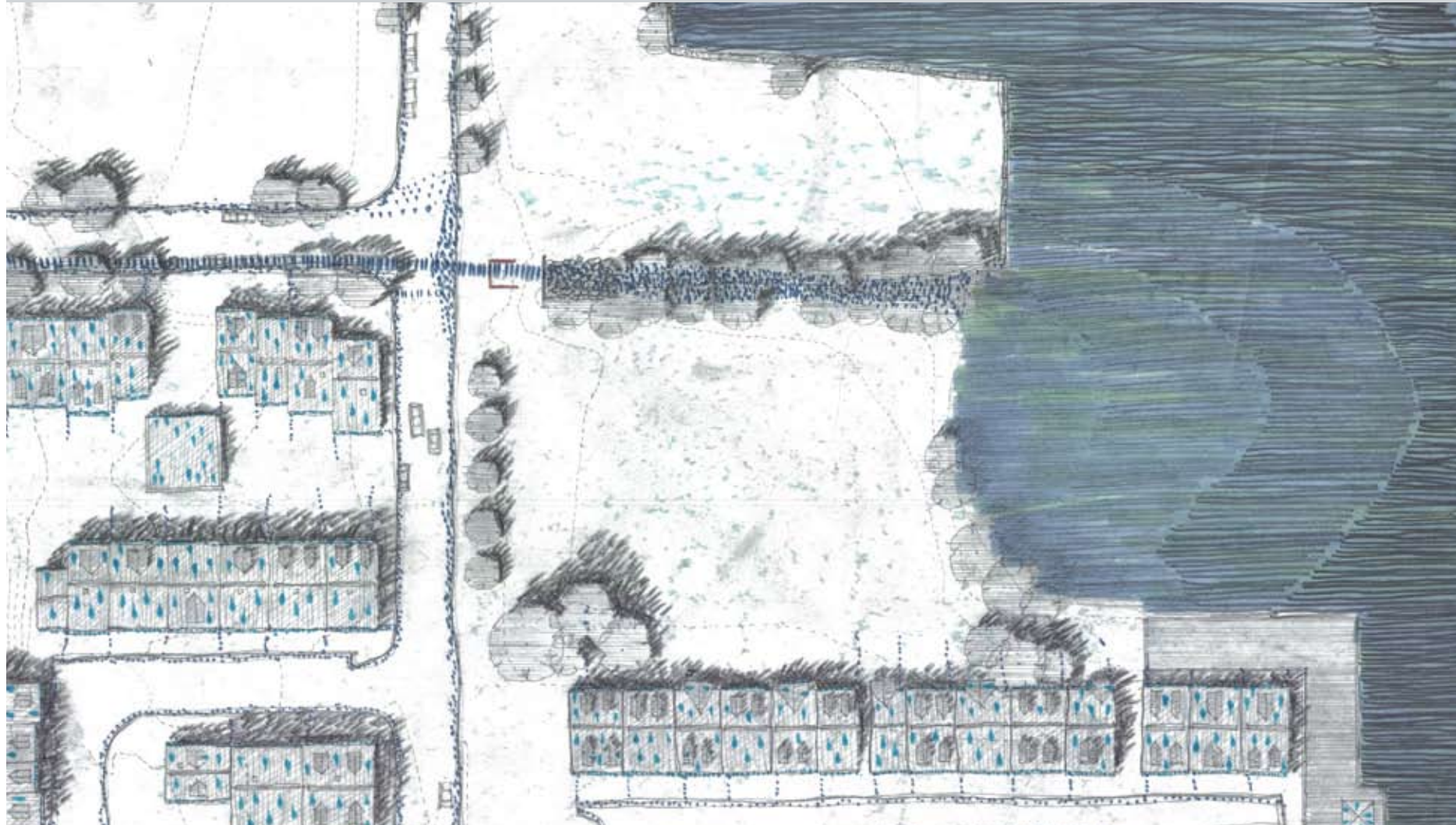

STORM WATER

When various types of precipitation reach on impervious surfaces, those become no more poetic or romantic elements. Romantic rain, poetic drizzling, lovely snow, and beautiful icy crystals are changing into mathematical and engineering numbers and figures in order to protect overly developed area. Stormwater has two main issues. One is about the quantity and frequency of water runoff on impervious surfaces such as parking lots, building roofs, and roads. The other is about contamination that is saturated with polluted air before it heavily condensed and dirty condition on flowing surface. In this project, I concentrate on the process how bodies interrelate natural circulation through water. Rainwater becomes stormwater in urban setting for my site and it flows into river. River water goes to the ocean and is evaporated. And it revisits the earth as the form of raining. This big circulation of mother of nature is the place where bodies originally belong to. Stormwater is obvious proof that shows our secession from cosmos and the way to get back from broken linkage of human life with nature. The building is directly connected to the stormwater discharge from Gibbon Street through the first water detention with overflow. The project is including water treatment function as the building element to purify stormwater and it is used for body treatment process. Eventually, stormwater goes back to river with celebration of healing body and cleansing city.

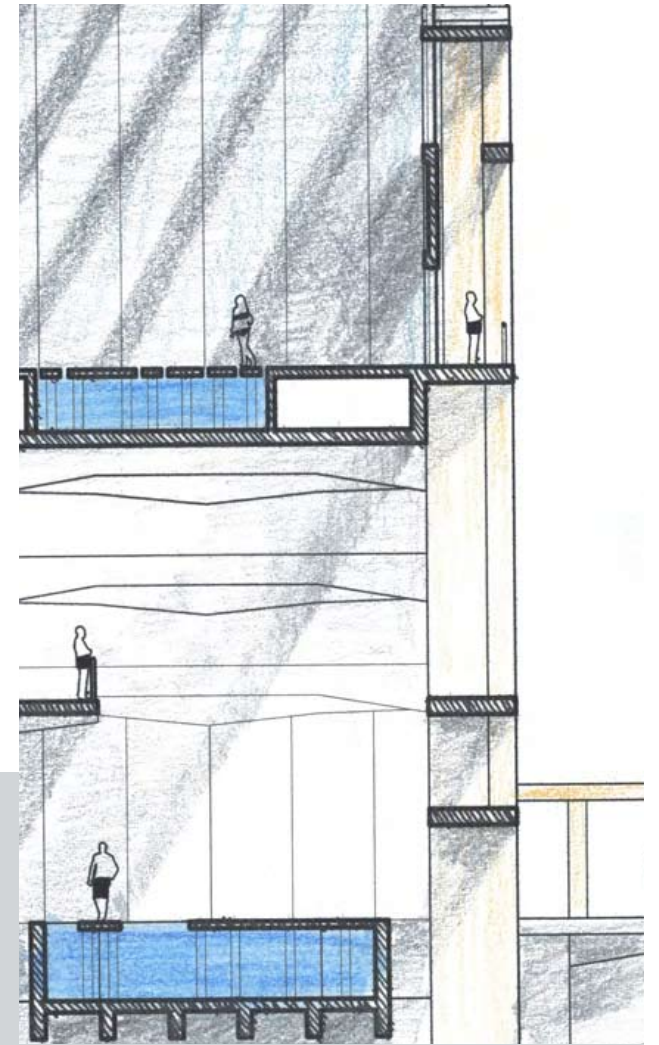
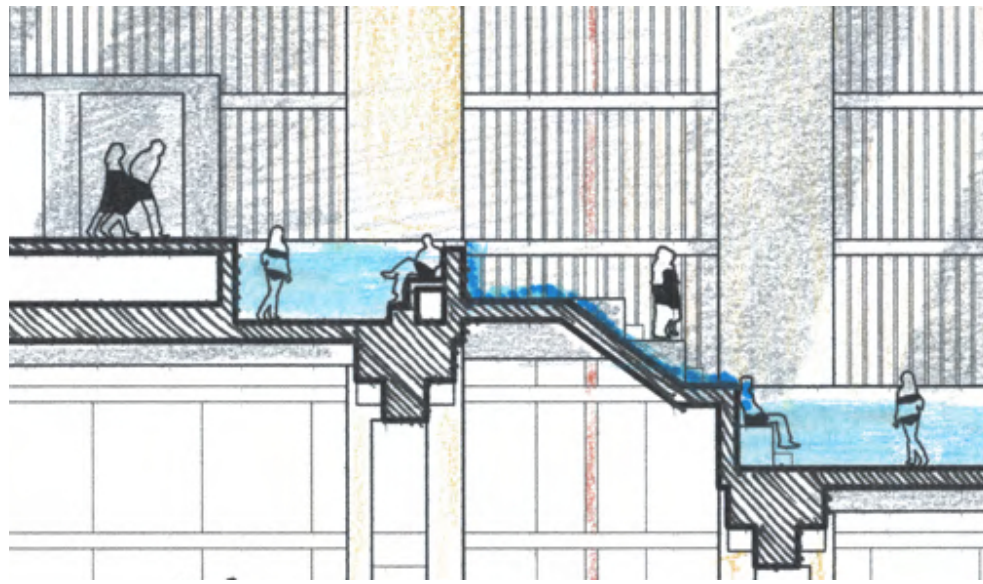
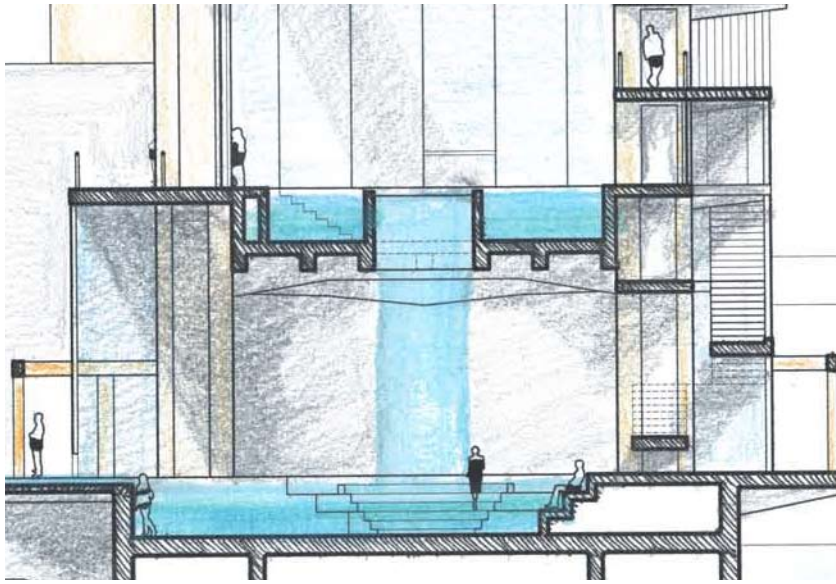

body and water

BODY AND WATER

In ancient times, water was considered a gift from the gods. Control and command of water symbolize power and wealth. No one dared to change the cycle of nature even though the religious concept on water no longer existed. Using and enjoying water is more sacred and religious procession. Kuriyama describes about body and environment, "Where Airs, Waters, Places surveyed the sculpting of physiques by local airs, the anatomical forms admired by the dissector reflected the purposeful articulation of matter by innate breath. Parts ceased to be mere shapes, schema, and became organs, implements of the soul; and muscles, in particular, were born as the organs of voluntary motion, actions determined by the self. Where once pneuma served luck, in the flexing of muscles it expressed decisive will."⁴ He explains how the physical body component and its mechanism interact with environment. Each individual organ is functioning and reacting with air and water to create life and that becomes the expressiveness of living existence. This is the moment that invisible soul is expressed by physical organ reaction with air and water. Body treatment process is a clear way to watch this reaction to different types of water on temperature, pressure, and smell. Discovering the process of reaction within body and water shows the way of characteristic expressiveness of living soul that is generated by physical organism.

4. Kuriyama, Shigehisa. *The Expressiveness of the Body*. (New York: Zone Books, 2002). 269.

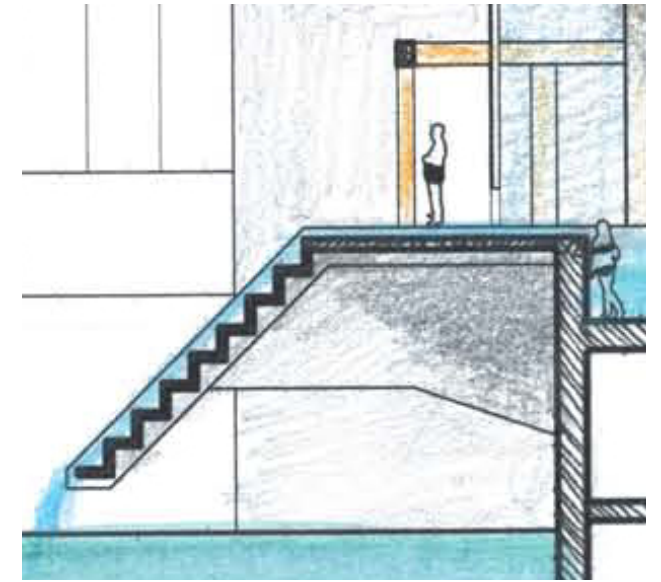
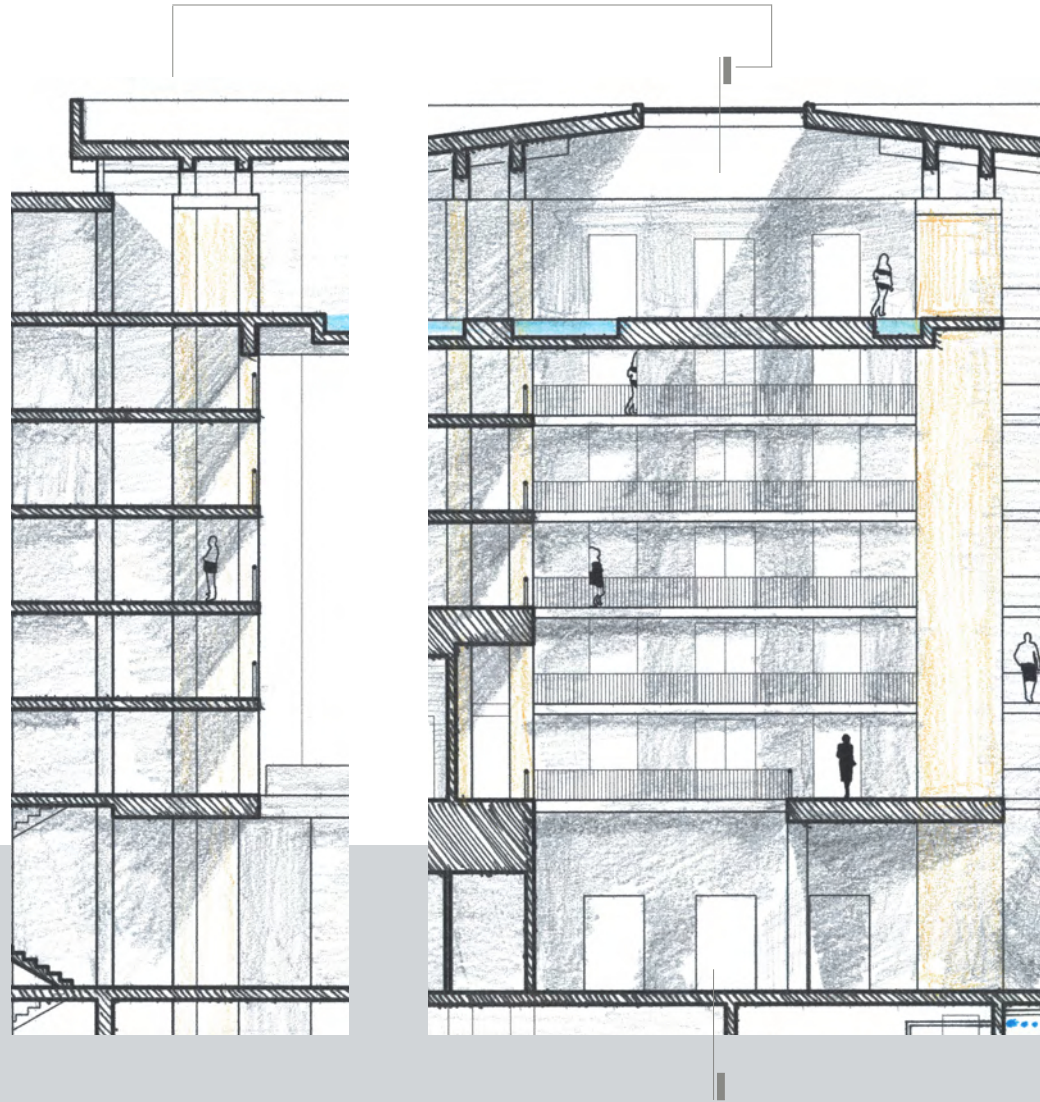

RETAINING WALL

Retaining wall is not only for holding a mass of earth against overturn, sliding, and settling but also for creating mound and platform for dwelling place. In this project, I use retaining walls to understand a threshold and embodiment of differentiation between nature and man made space. Boundaries define river water and habitable ground that are articulated real experience of construction with certain materiality. Stone retaining walls with stadium sitting stairs create easy access to the river and elevated platform for outlook. These walls generate perception of special boundaries that make people experience the entirety of space and nature. That totality of experience is composed by tangible material. In other words, we are designing concrete architecture objects motivating and producing real phenomenon within nature and man made space that is defined by boundaries.

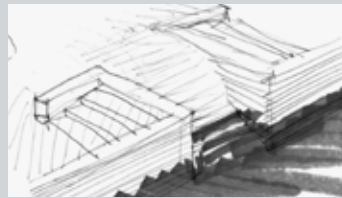
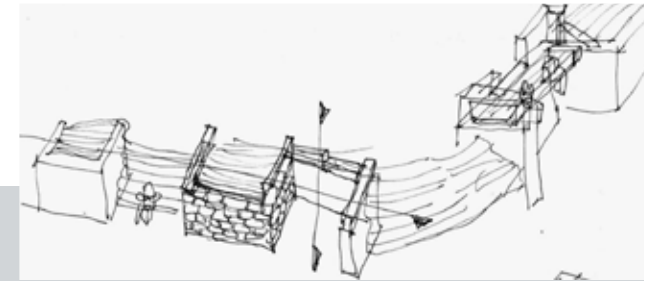
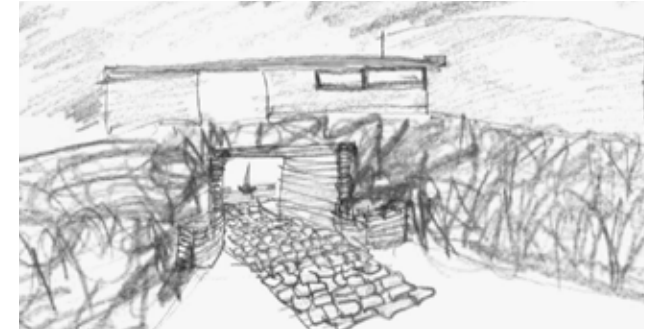
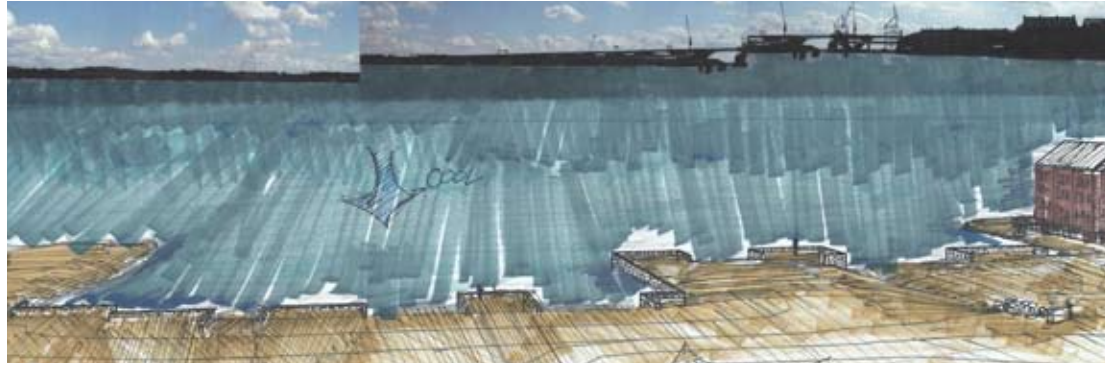

the beginnings

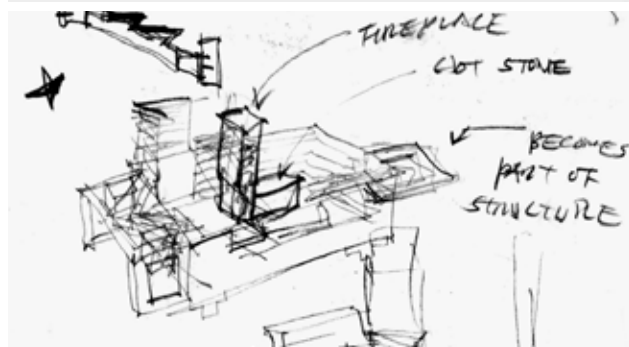
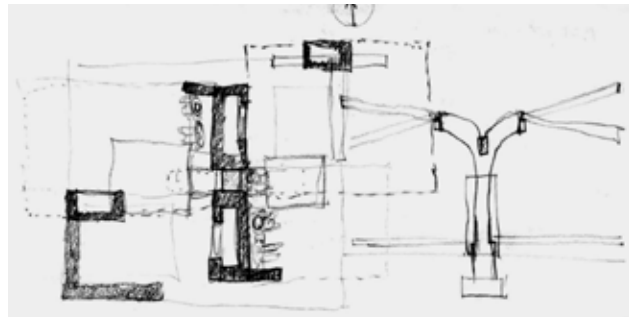
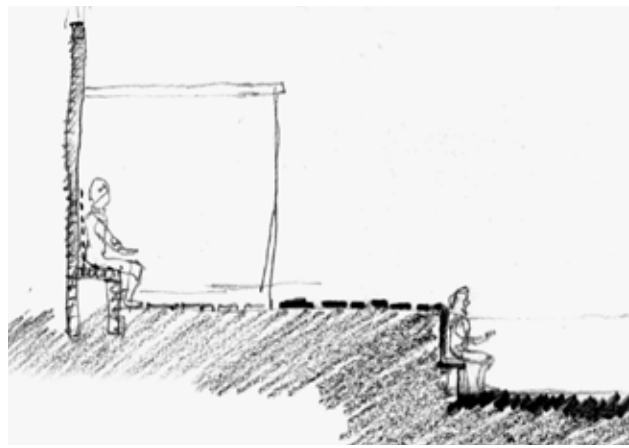

HEARTH

The origin of form making was established by notion of hearth, which is gathering place and surrounding wall that protected the hearth and people. And that wall grew to the roof that was connected to the wall. This consequence of form making was deviated into two typical dwelling types. One is a wall-dominated, courtyard style in the south and the second is roof-dominated, enclosed style of the north. Semper determined the “surrounding wall” as the prehistoric origin of the dwelling for the southern races. He defined hearth as the cultural gathering place developed into social and spiritual center point. Semper explained the “hearth” in his book “The first sign of human settlement and rest after the hunt, the battle, and wandering in the desert is today, as when the first men lost paradise, the setting up of the fireplace and the lighting of the reviving, warming and food-preparing flame. Around the hearth the first groups assembled: around it the first alliances formed; around it the first rude religious concepts were put into the customs of a cult.”⁵ Through this project, notion of hearth is interpreted in forms of social gathering and group treatment by hot water and radiant heated stone floors. Heat stimulates the metabolism of body just like the circulation of water on earth articulate the life of our planet.

5. Semper, Gottfried. *The Four Elements of Architecture*. (Cambridge, England: Cambridge University Press, 1989), 102.

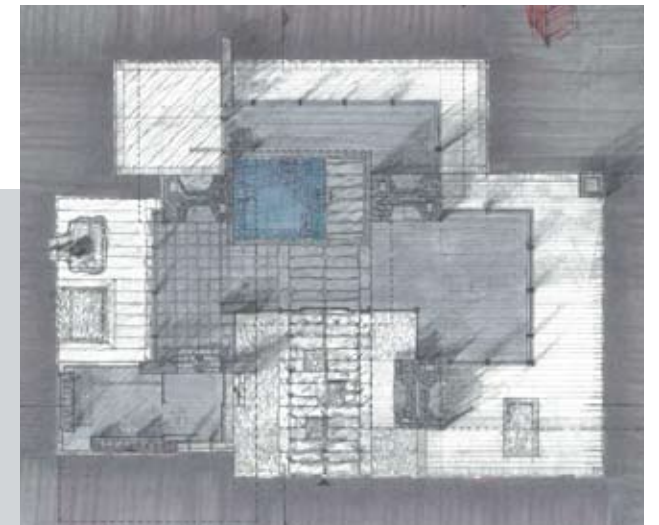
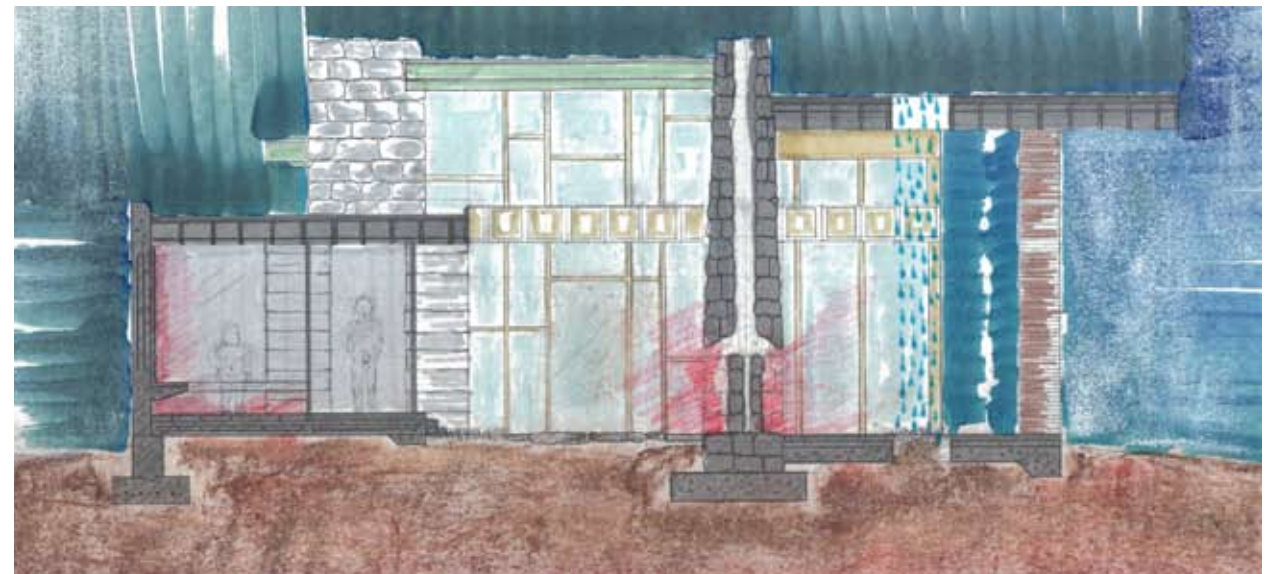

BATH TUB

The elevated tub concept is derived from the Farnsworth House by Mies van der Rohe. It is raised 5'-3" above the ground because it is located in the floodplain of the Fox River near Chicago. The edges of the roof, the raised floor and the terrace are framed with 15 inch channels. The core containing two bathrooms and mechanical room, a fireplace, built-in cabinets, and kitchen was constructed on that raised floor with penetrating boiler flue, combustion air intake, and outtake, and kitchen exists from the floor through to the roof. The relationship between the raised floor and mechanical core of the house is fully presented in this project as reinterpretation of mound from Semper's account. Separated tubs are laid out in specific way of composition in order to show the relationship with the body treatment flow and river flow. The manner of connecting tubs generates water to cascade down into the Potomac River.

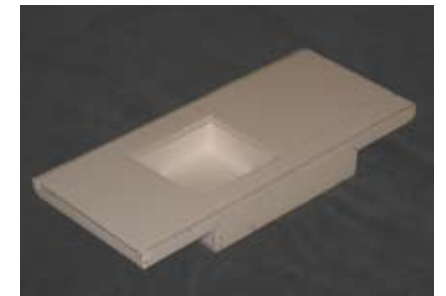
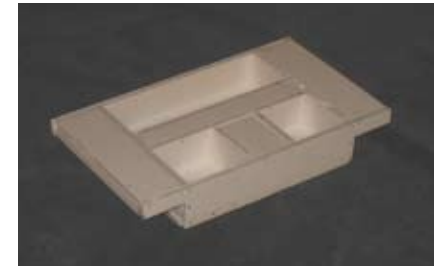
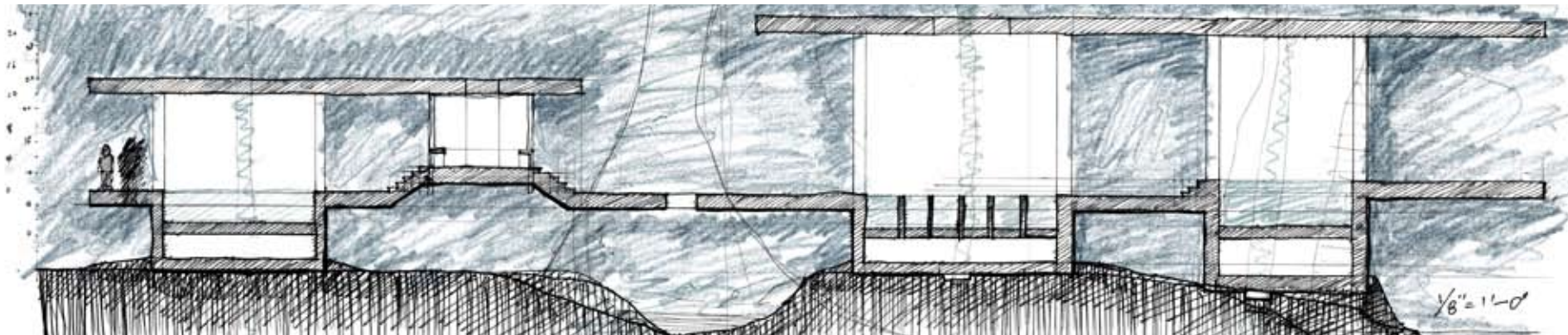
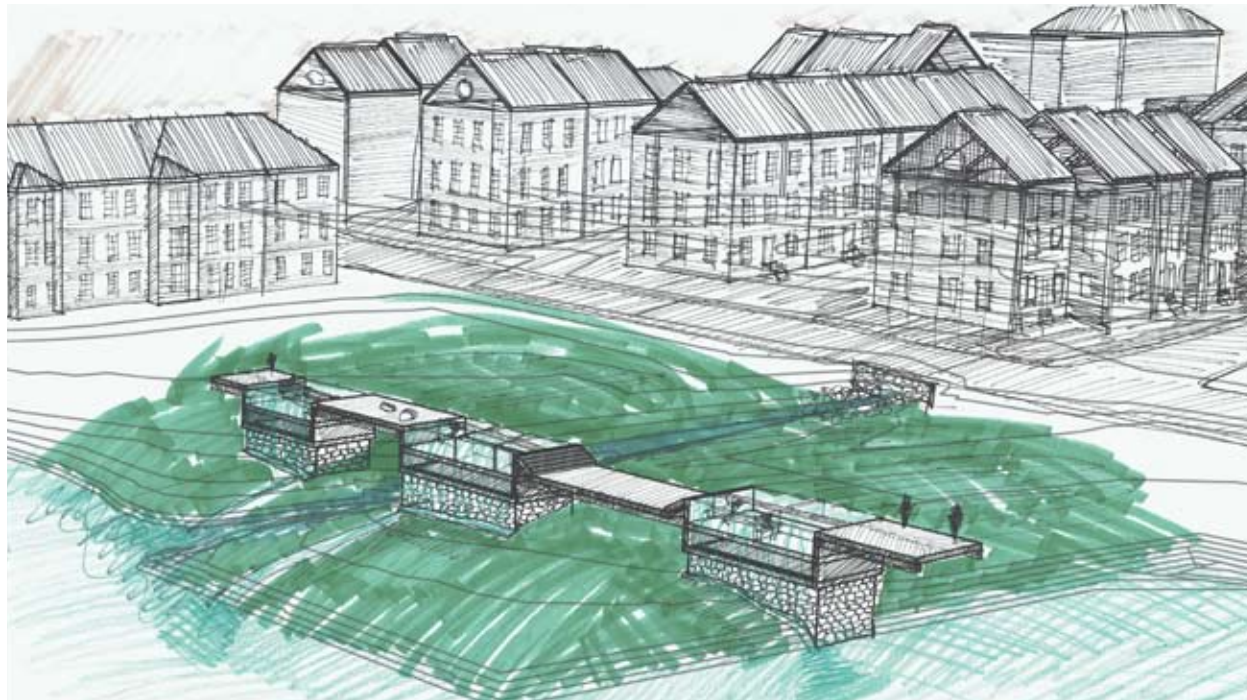

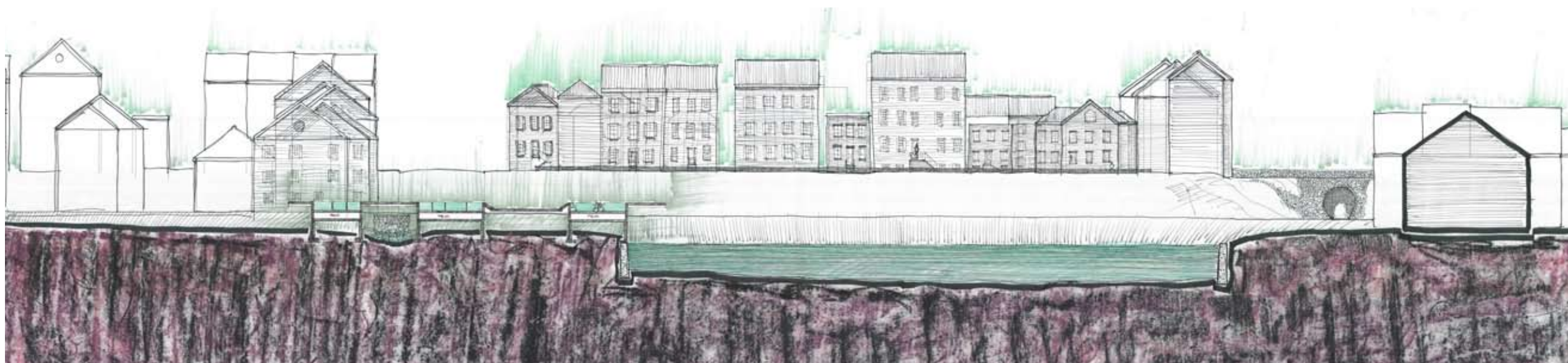
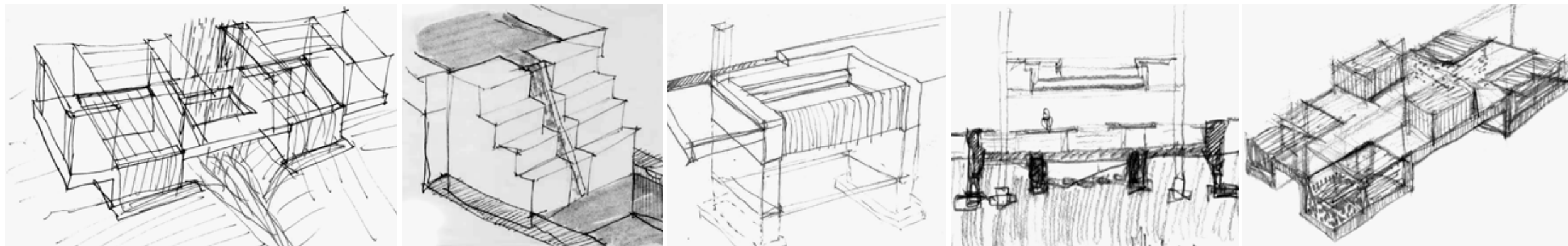

WALLS

The form is the geometrical understanding of space which is experienced by materiality. In other words, without tangible material we can never recognize and identify what space and form is. We can perceive the space through experiencing of concretized architectural element. Walls are basic element we recognize as form and space. Semper believed the origin of architecture is rooted in the process of making fabric. Weaved mats and covers derived from knotted materials progressed into wicker work due to needs of firm framing or solid walls. In this project, the weaving brick walls are developed into concrete reinforced wall to support roof structure and the heavy weight of pool. Two 'L' shaped walls are laid out to experiment how walls construct places with practical needs. The layers of wall create characteristic enclosure to accommodate pools and become elements to concretize things which compose our given world such as sky, water, earth, wind, and light so we may comprehend principles of nature into our experienced perception.

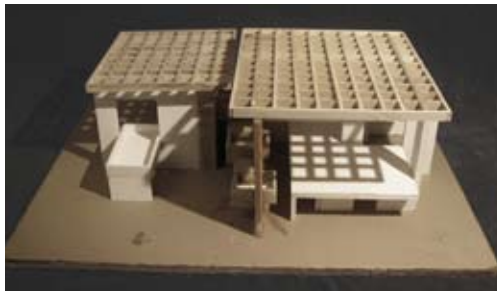
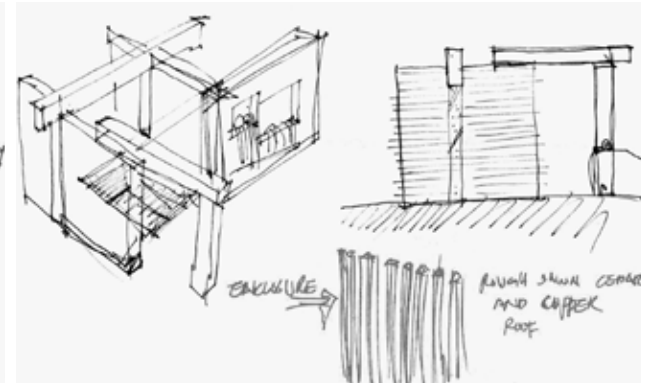
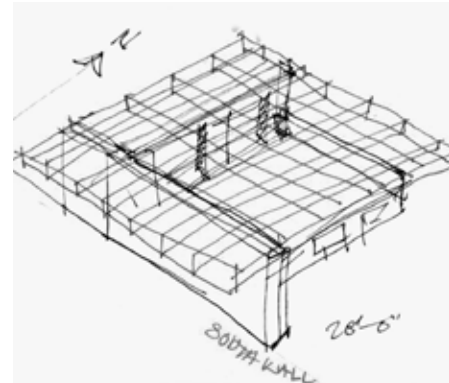
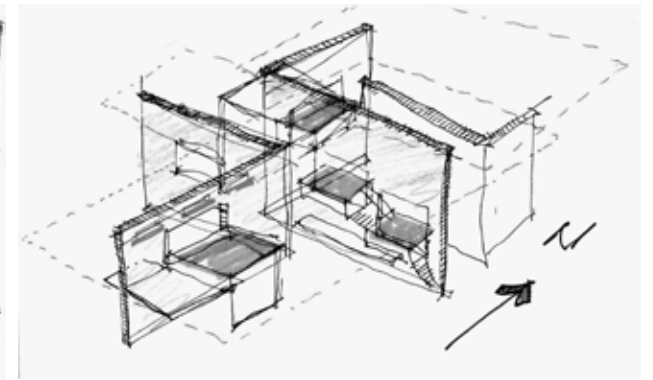
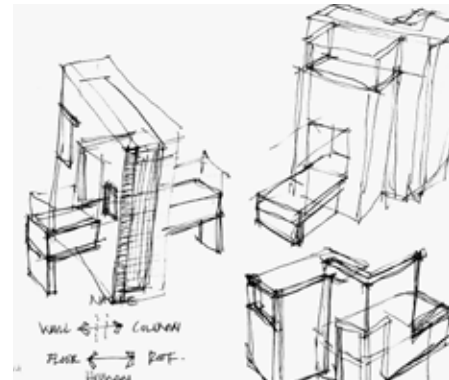
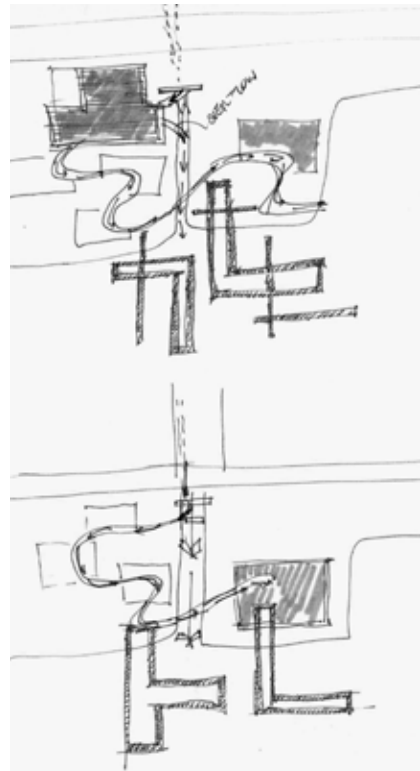

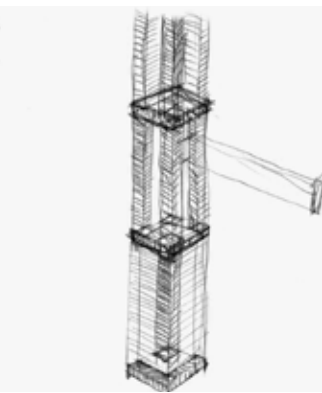
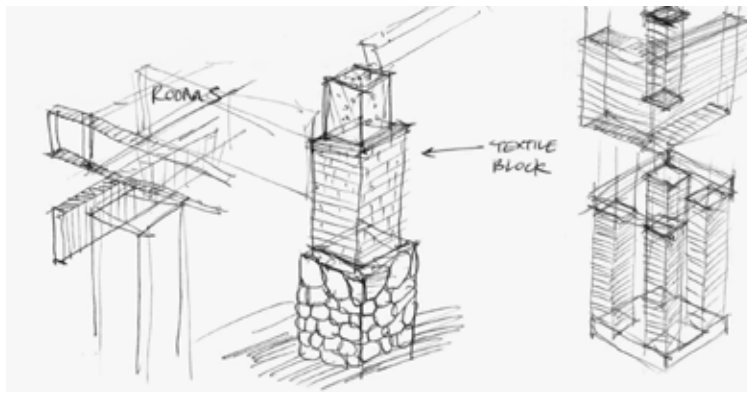
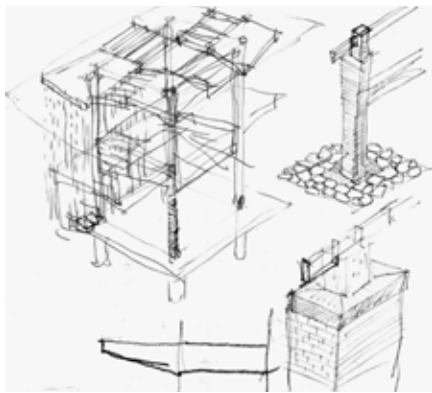

COLUMNS

We transform our social needs to mathematical space dimensioning on process of programming. In order to create physical space that is defined by program, we use architectural components. Column is one of most important entities to carry on the weight and gravity horizontally. It is very slender, rigid, and strong on compressive loads at the end of member. Columns are monumental figures connecting sky and earth through foundation system. During the process of design, columns are developed not only structural members to hold up pools and habitable floor area but also generate transitional space that gives us presence of architecture existing between man and cosmos. Some piers extend the floor area above river to form a dynamic relationship between flowing river water and elevated mound that are created by retaining walls. Columns become a bridge by bracing beams and floors so that conceptual relationship among body, water, and architecture is realized by totality of construction.

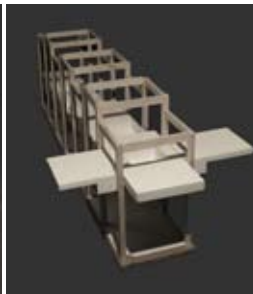

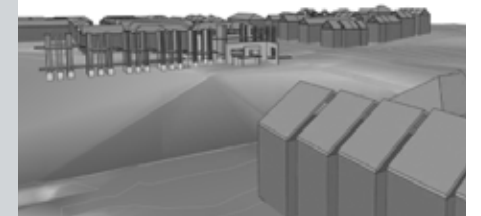
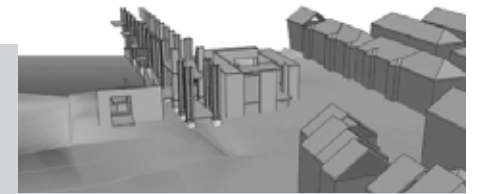
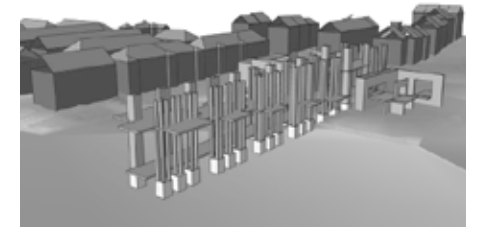
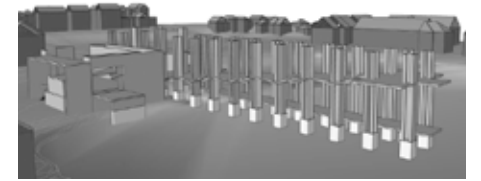
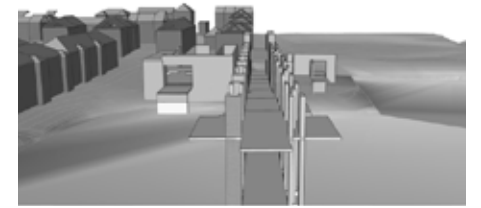

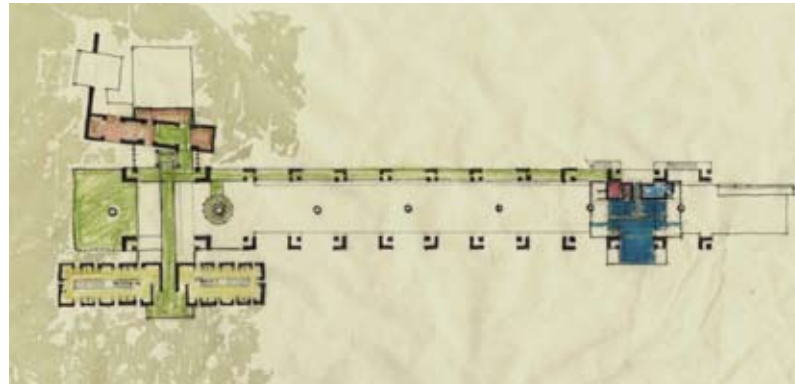
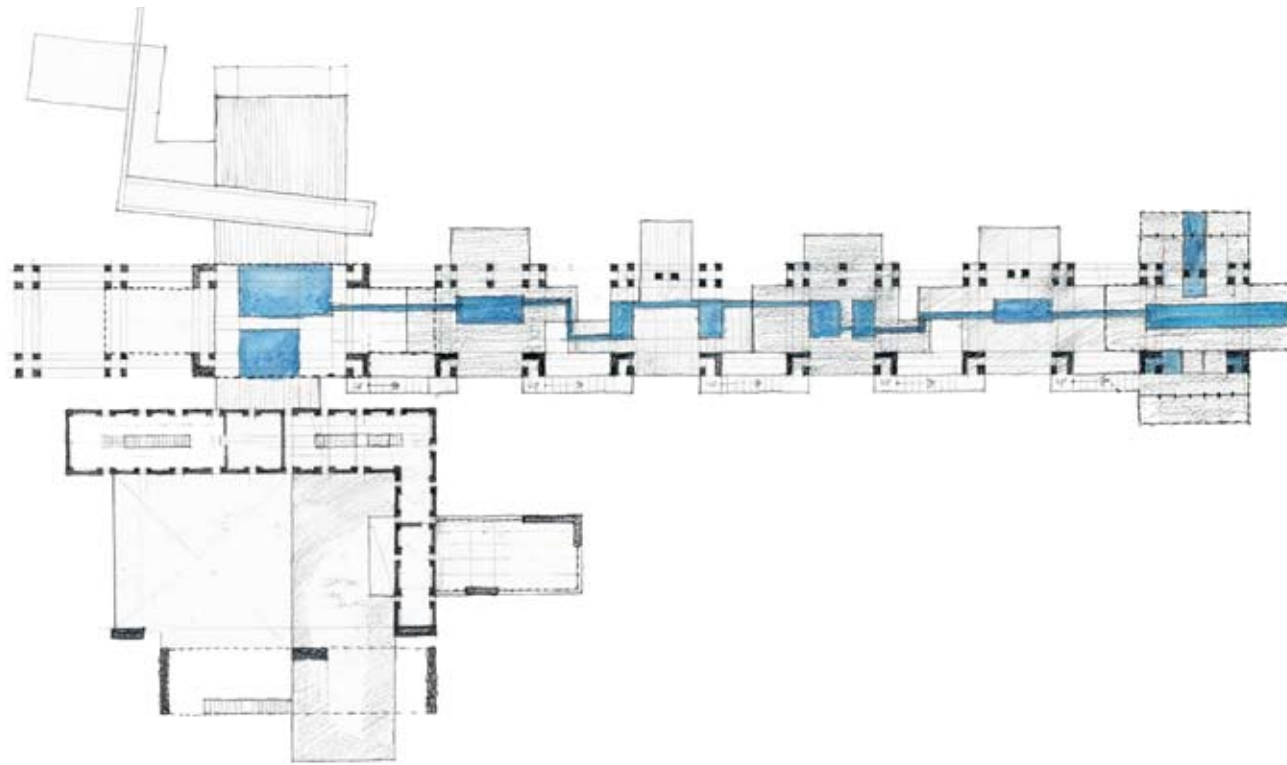

WALLS AND COLUMNS

The geometrical form is perceived and engraved in human understanding through the defined space by certain material in representation of architecture. Walls and columns are very important elements that compose space and form in this project. Separately developed columns and walls are merged in this stage of design according to the characters of columns and walls. Columns have more male character in shape and use. These are conquering element to extend the building boundary from the ground to river. The serial columns create vertical monumentality and a bridge structure hanging up body treatment pools above river level. On the contrary, walls present female disposition on constructing for forms and space. These feminine enclosures are used for changing and cleaning area that needs more privacy. This characteristic interpretation is not only for accomplishing practical need for space program but also for transmitting the original meaning from symbolic forces to tangible forms. This process is enjoyable route to discover how abstract universe is being presented as a concretized physical world. The various architectural elements such as column, gable, arch, beam, dome, tower, wall, foundation, door, window, and chimney begin consolidating thoroughly so that each individual element can represent the deeper meaning of existence.

MAIN CREATION

The building is composed of three main components. The first is storm water treatment part which collects and filtrates storm water from the inlet at the end of Gibbon Street. The second component is main service block which supports the water treatment section and body treatment section such as main lobby, changing room, cleaning room, mechanical room, and circulation. Lastly, the third component is aqua therapy section which treats bodies with filtrated storm water from the inlet and roofs.

It is situated at the end of Gibbon Street. 390' x 62' overall dimension of building occupies the site from east to west. Basic structure concept is reinforced concrete columns and beams construction with limestone cladding starting from the ground with series of columns and ending on the caisson structure of island. The basic water flow and circulation is driven by treatment process. First, the storm water treatment is the main feature of the building that expresses healing of city. Secondly, filtrated water heals and cures people who are in need of treatment.

Aqua therapy process starts on the fifth therapy level and flows and cascades down through the first therapy level by nature of gravity. Eventually, the water ends up into the artificial island which is constructed by caisson structure in the middle of the Potomac River. The water at the end of the treatment process on city and body travels back into the Potomac River.



main creation

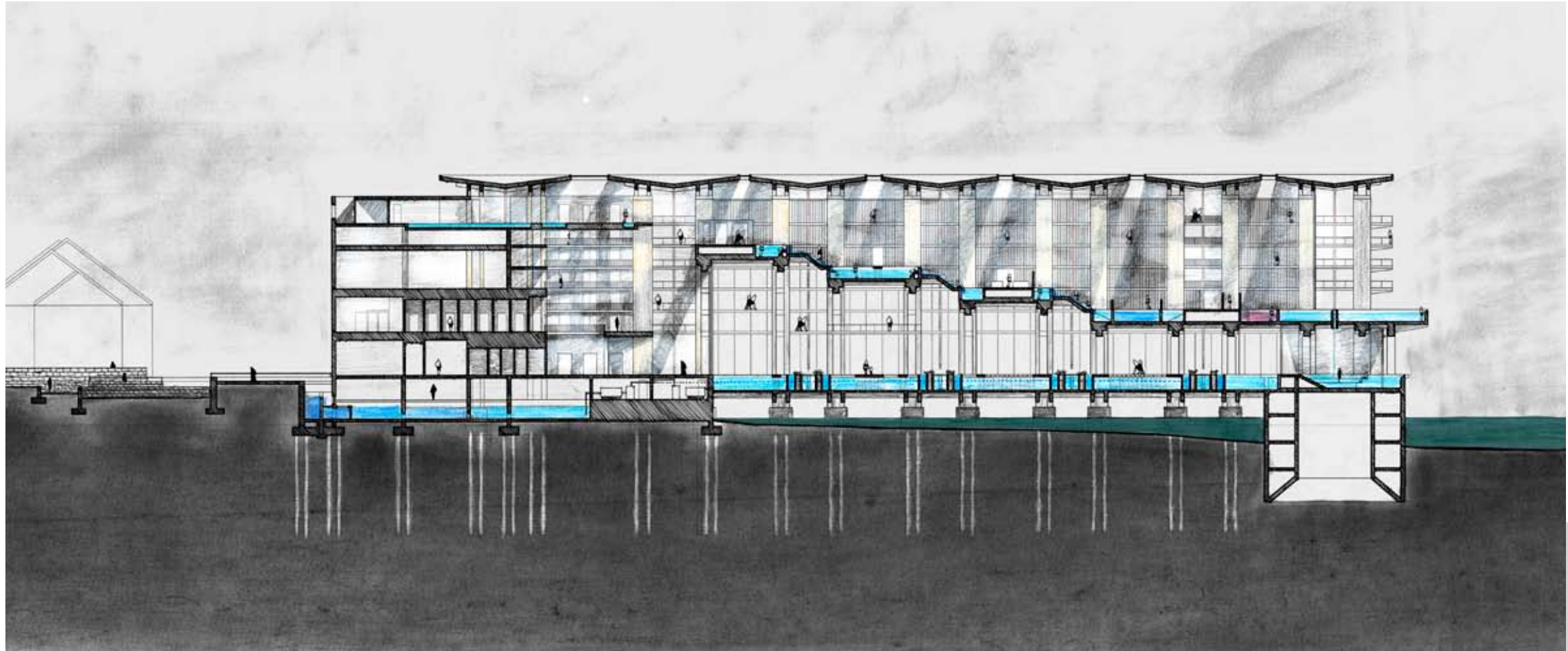

WATER TREATMENT

The triangular pond is installed immediately next to 3' diameter concrete storm water inlet in order to process the first stage of water treatment. This stage is the preliminary filtering process to remove large debris and to aerate storm water before initiating the secondary process in the building. Filtered water in the preliminary stage is supplied to secondary hard core treatment process to remove sludge and scum inside the sedimentation tank. Chemical treatment is done with the purpose of killing bacteria. The final process is the wetland plants system which is the most naturalized method in procedure. Water which is processed through the secondary treatment is sucked by pumps and is transported into sedimentation filtration area that is divided by bulkheads partitions to stabilize the speed of water flow. After this process, water flows into fine stone chamber with vegetation roots for finishing cleaning process. The water from the roof is less polluted compared to the water from the storm water inlet, so it goes directly into the final water treatment process from the roof, which collects rainwater. Final process becomes more architectural entity than mechanical facility. People can enjoy the water treatment process while they travel from the lobby level prior to the start of aqua therapy. Final treatment process pool is the bridge connecting main lobby and final body treatment pool. The water in this final pool is re-circulated to the mechanical room which has re-filtering system.

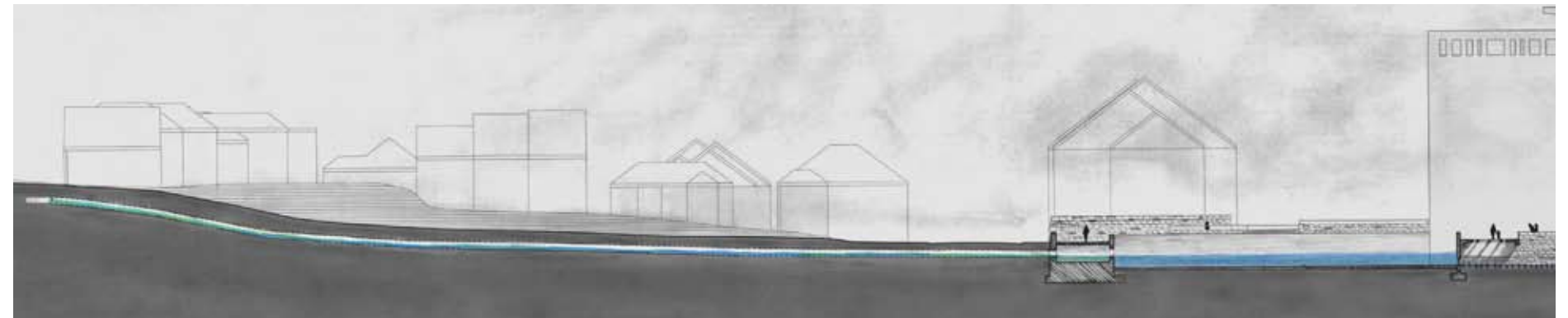
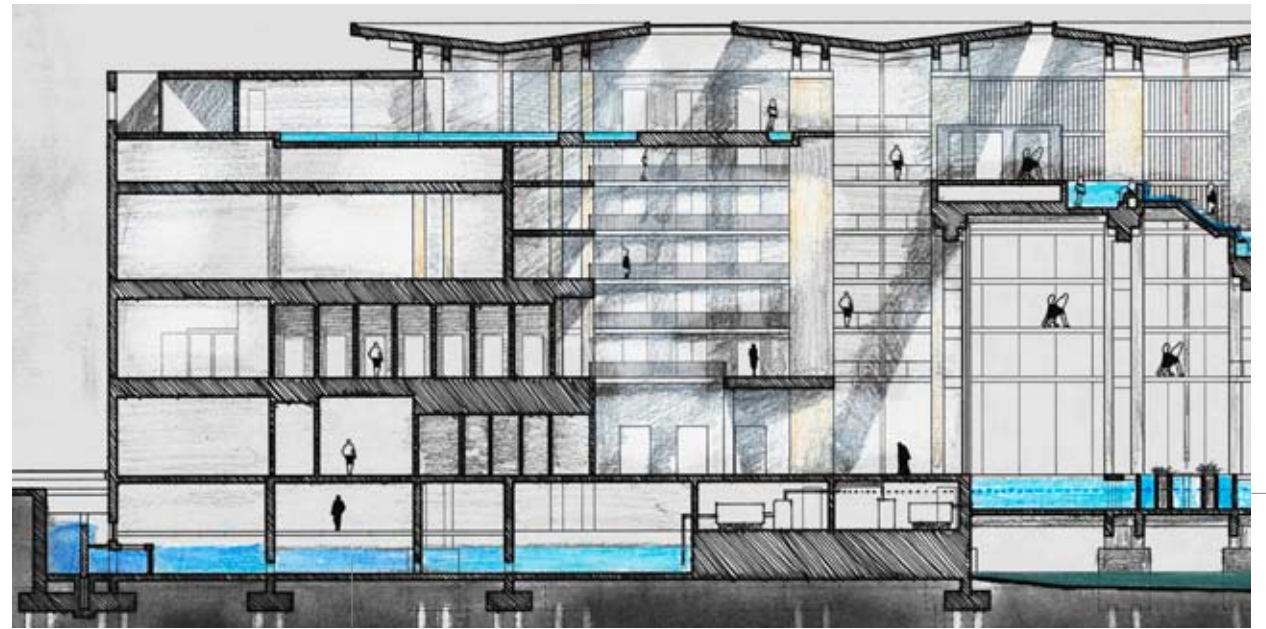
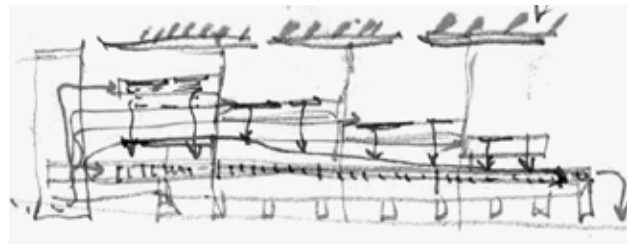
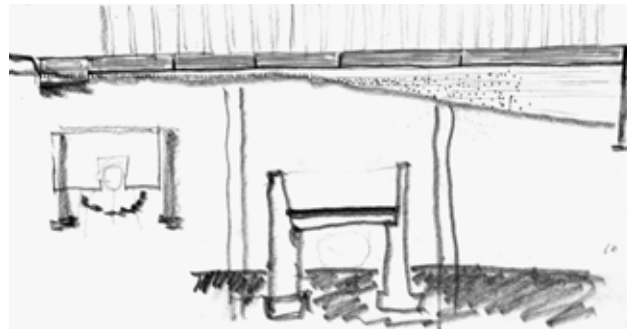

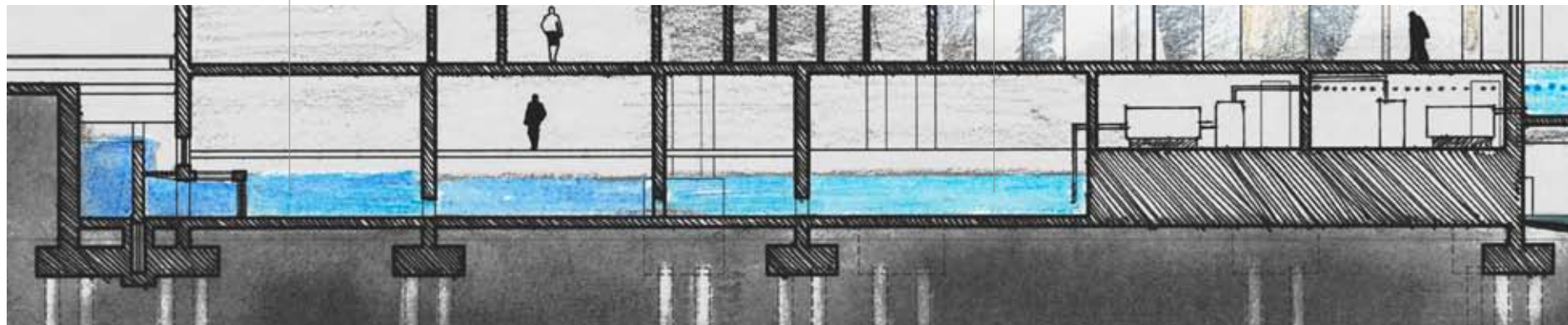
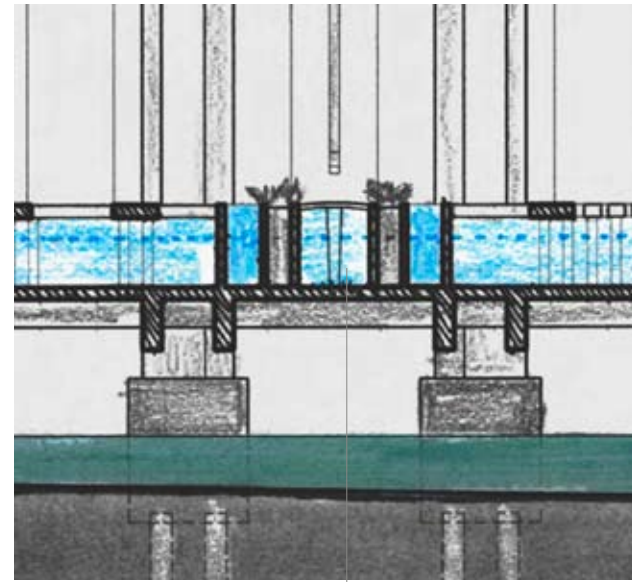
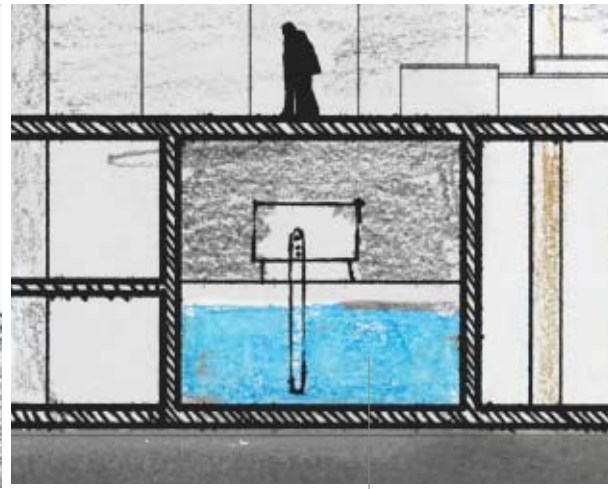
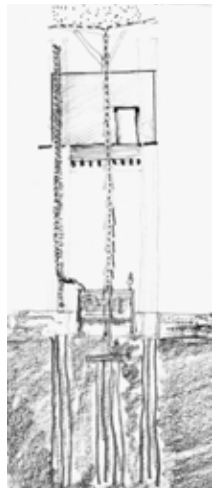

APPROACHING THE BUILDING

The main gate is located on Union Street. The public enters main landscape area from Union Street about 8' higher than the water level. People encounter stone walls dividing landscape geometrically which creates proportion into intimate public scale. Different heights of platforms develop various sense of outdoor space which leads the public to main entering linear pergola structure adjacent to triangular pond. Immediately next to the pond, there is a lower level garden making physical connection from the pond to the main entrance of the pergola. The surface is paved with rectangular rough granite. Between the pergola and the main building are connected with small bridge covered by metal grating emphasizing and celebrating water overflow from the pond to Potomac River. The bridge leads into two different locations, the main building entrance and sloped riverside outlook.

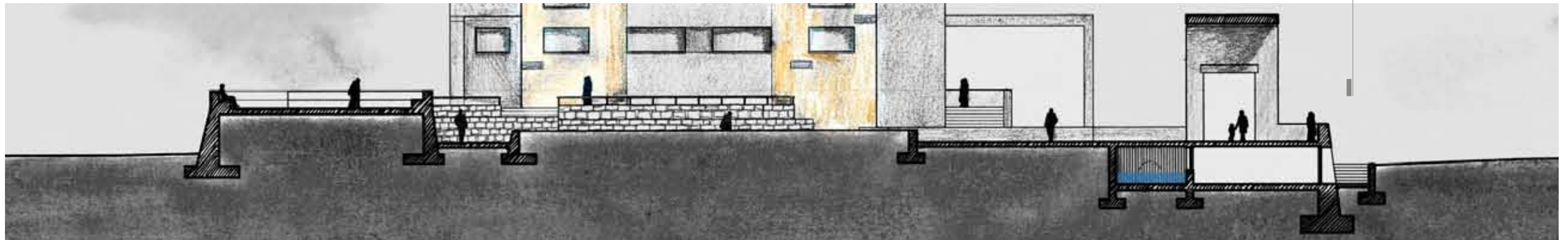
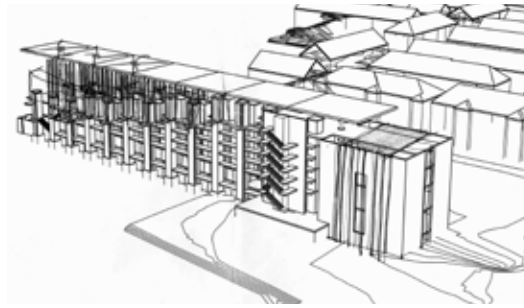

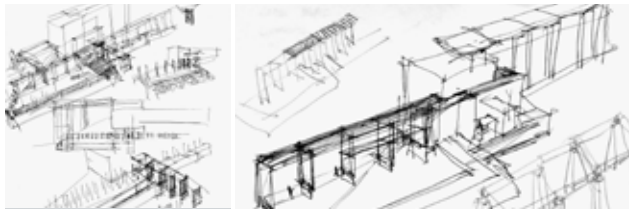



CHANGING AND CLEANING ROOM

Disrobing is a very sacred and religious progression revealing desire of cleansing. People have longed to clean their physical body and spiritual mind. Public enters the building after climbing main outdoor staircase and passing the foyer encompassed by exposed concrete walls. Once inside, the main reception desk and large scale glass wall are visible. From the reception area to the changing room you must pass through the columns and stepping stone pond. The changing room and cleaning rooms are directly joined by staircase passing through columns.

A set of seven shower stall, one dry and wet sauna rooms for men and women are located within the cleaning room that directly leads people to the main circulation staircase. People begin their journey to experience body treatment process from the cleaning room after taking light shower. 16' floor height creates enormous openness and mechanical space

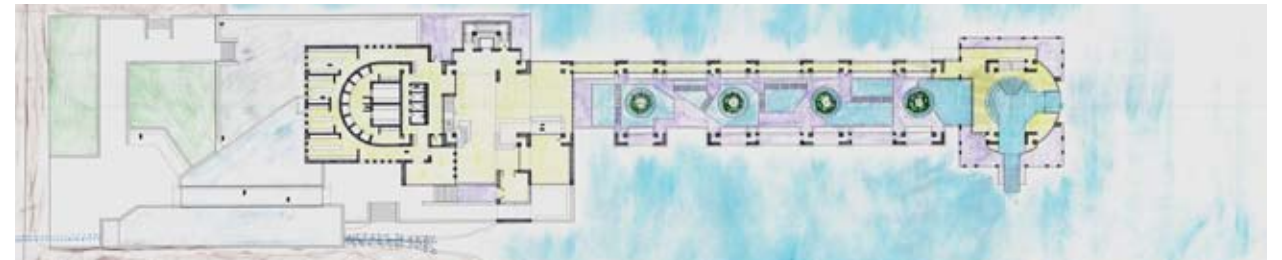

CIRCULATION

There are three major circulation components connecting body treatment pools from the main lobby and building service area. The first is main vertical circulation including staircase supported from exposed concrete wall with steel framing around a hydraulic elevator. It is enclosed by glass curtain wall to emphasize the view from the north side facing Washington D.C. The second component is a horizontal corridor linking each therapeutic pool from the major staircase which creates another layer between exterior wall and maple finished interior wall from the north side of the pool. The third one is the horizontal passage which weaves in and out among the columns that connect horizontal corridors vertically.

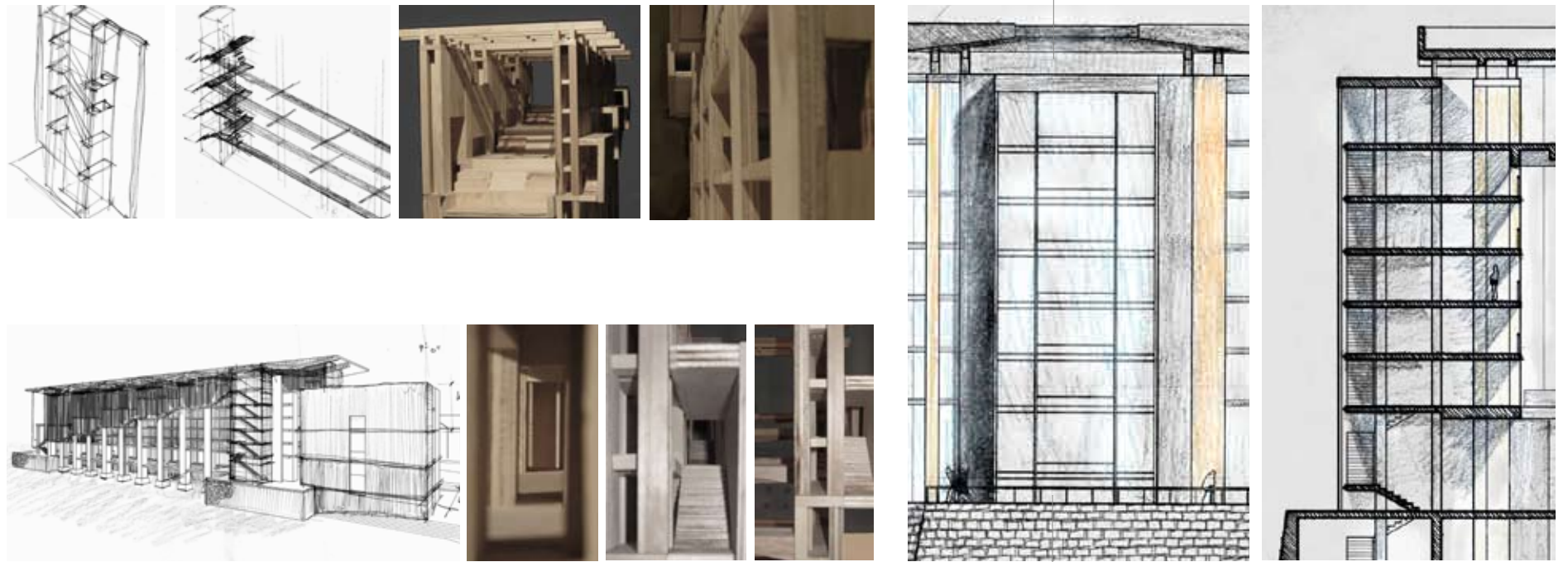

BEAMS AND TUBS

Beams are designed to support both the weight of water in the pools and dead weight of concrete pool structure. Beams are spanned from reinforced concrete columns with limestone cladding. The longest span is 32' beams spanning short axis of the building from north columns to south columns. The second longest span is 22' beams spanning short axis of the building from east to west supporting the pool floors. The shortest span is 14' beams spanning from east to west without supporting the pool structure. The 14' beams are working only to brace the building and support the skin columns. The heavy beams become monumental ceiling element presenting the movement of gravity from the roofs and floors to columns. The enormous concrete beams are designed to show two different types of stress separately. Compression is relieved by two side pieces of arched shaped concrete beam and tension is released by one center beam which is deep bowed shape.

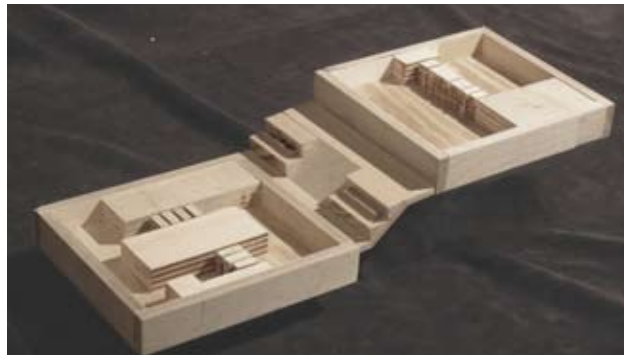
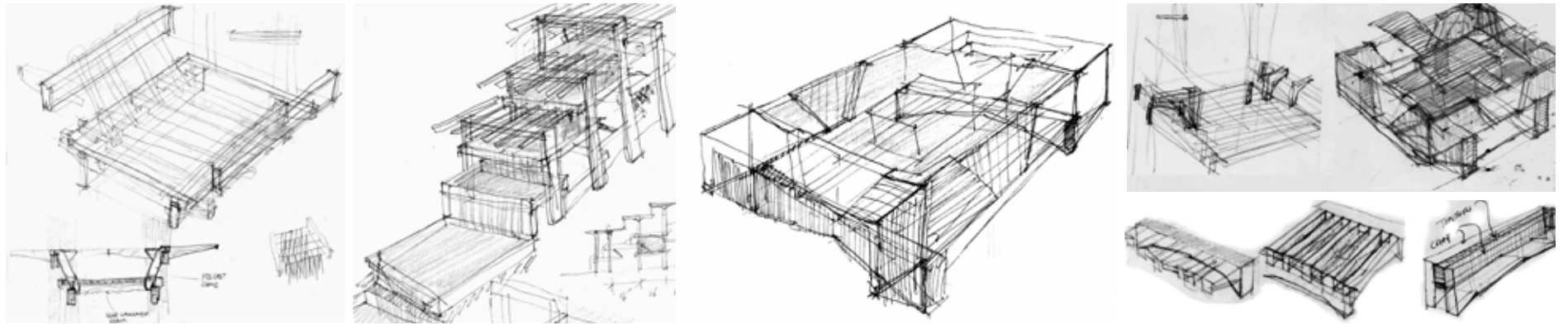

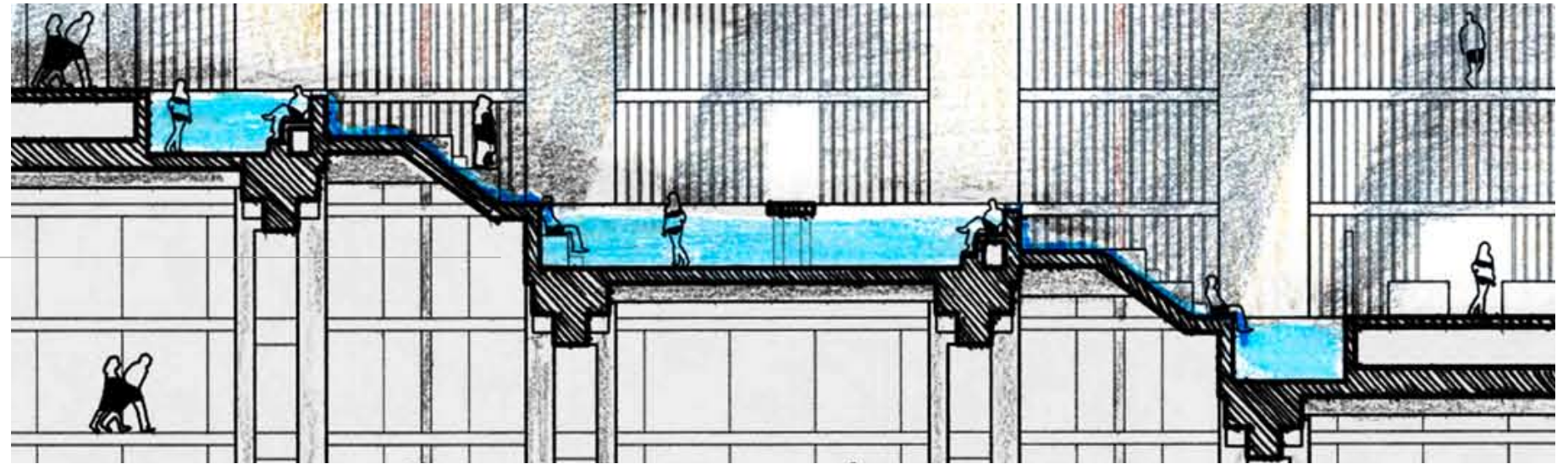
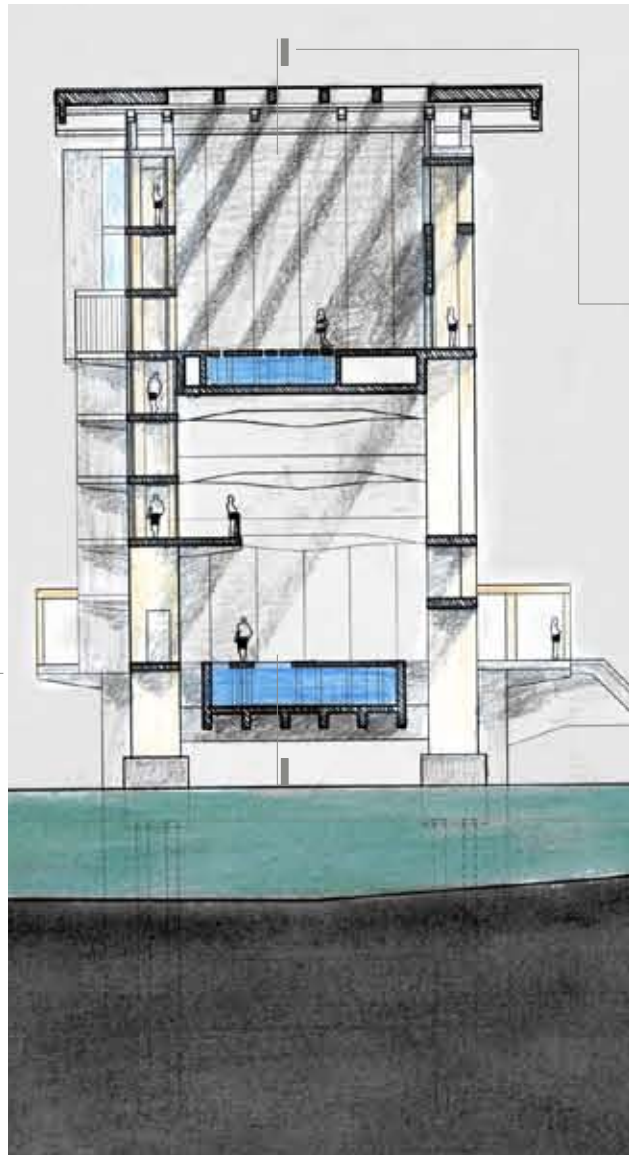



BODY TREATMENT

Aqua therapy process is structured with five levels of pools and radiant heated floors. There are three different water temperatures to treat the body. Warm water cascades down to lower levels eventually streaming out to the Potomac River. Hot and cold waters are maintained separately on each different level. Sloped water way creates foam water while it flows down to each heated floors are located on each level for the public

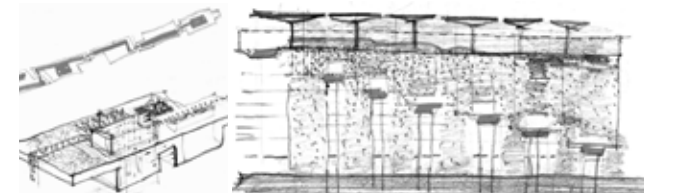

to lie down or sit on stone finished floor system. The depth of pool varies between 3' to 3'-2" according to the flow of water in the warm water tub. When standing in the pool and walking, water level covers the lower body from waist down. This is a very effective bathing method. Each level of pools is divided by different shape and function of tubs. The rough non-slip stepping stone surface serves as the main passage way, also functions as reflexology massage.

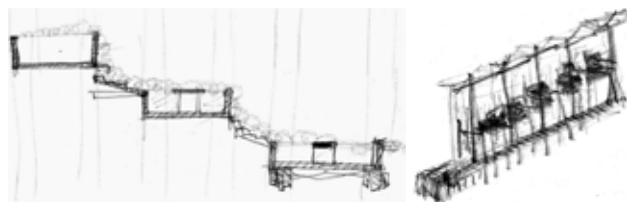

COLUMNS AND ROOFS

Two rows of 6'-4" square columns are positioned to the east from the ground. Columns support concrete roof structure that collects clean rain water. The collected rain water is transported down through the exposed rain leader to the third stage water treatment pond on the lobby level. Columns are hollowed to emphasize the presence of architectural entity for the users. They walk through the columns when moving from one pool to the next body treatment pools. Columns are weaved by beams and penetrating floors much like fabricated textile. 22' and 14' span alternates due to differentiation between spanning pools and spanning roofs. These different spanning defines sky light location above the middle of the pool and articulates spiritual light effect to the surface of finished material in interior space. The sky light opening also ventilates condensed vapor out of the wide opened treatment space.

