



The In-between:
Architectural Mediation Between
Commerce and Residence.

a study by
Tracie Tarel

The In-Between: Architectural Mediation Between Commerce and Residence.

a study by
Tracie Tarel

Thesis Committee and Advisors

Heinrich Schnoedt,
Associate Professor,
Architecture
Chairman of Committee

Michael O'Brien
Full Professor,
Architecture

William W. Brown
Full Professor,
Architecture

William U. Galloway
Associate Professor/Chair
Graduate Program,
Architecture

Hunter Pittman
Associate Professor/Chair
Professional Program,
Architecture



This thesis submitted to the Faculty of Virginia Polytechnic Institute and State University in partial fulfillment of the requirements for the degree of Master of Architecture College of Architecture and Urban Studies

S
U
B
M
I
T
T
A
L

The In-Between:
Architectural Mediation Between
Commerce and Residence.

a study by
Tracie Tarel

09
24
02

lee

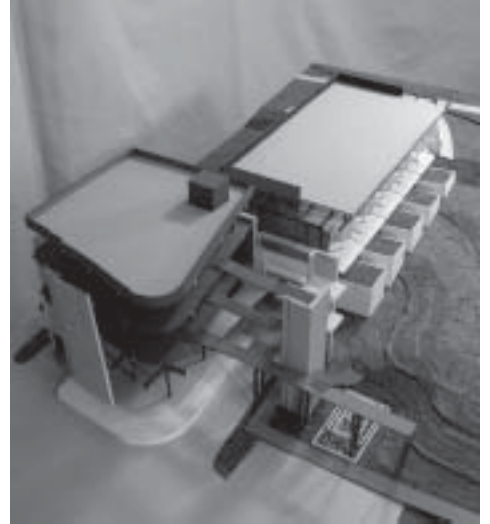

Abstract.....	7
Site Analysis.....	9
Program Development.....	15
Structure.....	19
Scale.....	20
Form.....	22
Hierarchy.....	24
Measure.....	26
Lawn.....	31
Parking.....	37
Retaining Pool.....	43
Public Path.....	47
Commercial Structure.....	59
Residential Structure.....	69
Concept.....	70
Offset.....	72
Refinement.....	74
Bath Box.....	78
Lawn Cube.....	84
Facade.....	86
Conclusion.....	91

Architecture develops from both the art and science of construction. Therefore, structure influences the pursuit of architectural ideas. Devoid of ornamentation, common objects can be enhanced through improving function and articulating their structure. Quality of construction and material durability have an immediate impact on how a thing is perceived. A thing is built once, but observed, studied, and used for its entire existence. It is important to investigate today's building necessities, such as a door, a path, or a wall, to discover inherent opportunities in order to transcend these everyday things and create extraordinary architectural moments. Separating a thing from its general context draws attention to it or to some aspect of it being enhanced. Otherwise, an ordinary thing such as a door can be quite uneventful. But, a door encased in a vertical plane of wood offset from the remaining enclosure draws attention to the quality, texture, and color of the wood.

In this thesis, the design of a multi-use, commercial and residential building, bridges between corresponding zoning districts. The project is used as a vehicle to explore the complexities and nuances involved in developing extraordinary architectural form using initially common conditions, local zoning laws, and standard construction techniques.

Abstract

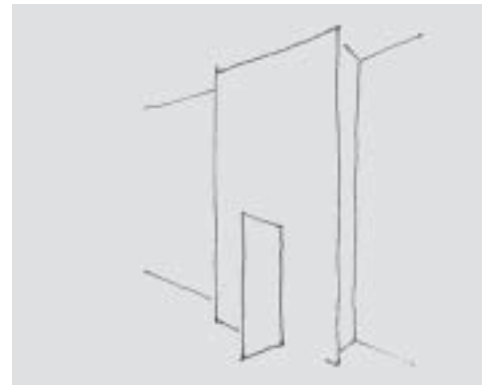



Site Analysis

APPENDIX A- BLACKSBURG ZONING ORDINANCE
Division 5. R-5 TRANSITIONAL RESIDENTIAL DISTRICT
Sec. 3050 Purpose.

The Transitional Residential District is to provide for a transitional land use between low density residential and higher intensity land uses. This is a predominantly residential district with neighborhood character. Special uses which are sensitive to and reinforce the residential neighborhood character are appropriate. These typically will involve the conversion or replication of single family houses. Properties along arterial and collector roads are particularly suited for such special uses. The livability or small-town character of the Transitional Residential District is made up of tree lined streets, open space, and greenways interspersed within a more urban residential pattern.





Site Plan



N. Main Street

The site is the combined lots at 707 and 709 Progress Street, N.E., Blacksburg, Virginia. One single family house, (approx. 1500 sq.ft.), located at 709 Progress St. will be removed for this proposal. The site is located in a zoning area designated as a Transitional Residential District. It sits in-between a commercial area and a residential area. An alleyway runs parallel to and between Main and Progress Streets.

Photographs depicting the two separate environments are shown below. The first is commercial Main Street at the Prices Fork Road intersection. There are four lanes of traffic, a number of restaurants, and a few commercial offices. Zoning district regulations change in the parking lot between 712 and 708 N. Main Street. As a result, height restrictions reduce from allowing sixty feet to allowing forty feet. The building at 708 N. Main Street is a two story building. The building at 712 N. Main Street is three stories, at a maximum height of forty feet. The site's southwest boundary is adjacent to a parking lot that sits between these two commercial buildings. The second photograph depicts a quieter scene, a two lane road, flanked by former single family houses. Most of these houses have been converted into multi-family rental units for student housing.



Progress Street



Site Plan



Section from N. Main Street to Progress Street

Closer examination of the commercial buildings adjacent to the site reveals that they have entrances facing the parking lot as well as the street. Current tenants in the two buildings are a video rental store, a physical therapy office, a kitchen accessory/wine store, an insurance office, and a day spa/salon. The parking lot provides spaces for fifty cars, three of which are handicapped accessible.

The most striking observation made while standing on either street looking across the site is that one can also see the character of the opposite street.

By combining two lots, the site dimensions are established to be 122' 0" X 184' 0". The major topographic feature along the southeast boundary is an existing storm-water retaining pond. This serves to facilitate local water runoff entering the water table instead of the city storm drain system.

Currently, pedestrians and bicyclists use the vacant lot (707 Progress St.) as a pathway to the commercial buildings, a shortcut to downtown, and to the Virginia Tech campus. Between November and January, the sun at sunset can be viewed from the higher elevation on Progress St. Prior to construction of the building at 712 E. Main, the sunset was unobstructed for a longer part of the year. Starting around the end of June, wild flowers bloom on the site in colors of lilac and red berry.



View from N. Main Street



View from Progress Street

Sec. 3051 Permitted Uses.

(a) The following uses are permitted by right in the R-5, Transitional Residential District:

<u>Residential</u>	<u>Civic</u>	<u>Miscellaneous</u>
Single Family, Detached	Community Recreation	Accessory Structures
Two Family Dwellings	Open Space	
Home Occupations	Public Parks and Recreation	
	Utility Services, Minor	

(b) The following uses are allowed only by Special Use Permit in the R-5, Transitional Residential District:

<u>Residential</u>	<u>Civic</u>	<u>Educational Facilities, College/University</u>
Single Family, Attached	Administrative Services	Education Facilities, Primary/Secondary
Townhouse	Club	Family Day Care Home
Multi-Family	Cultural Services	Homes for Adults
	Day Care Center	Life Care Facility

Program Development

(b) Special Use Permit continued

Nursing Home	<u>Commercial</u>	<u>Office</u>	<u>Miscellaneous</u>
Post Office	Bed & Breakfast	Financial Institution	Broadcasting or Communication Facility
Religious Assembly	Clinic	General Office	(Ord. No. 1170, adopted 11-11-97; Ord. No.
Safety Services	Neighborhood Convenience	Medical Office	1215, & 10, 5-11-99)
Shelter	Parking Facility		
Utility Services, Major	Personal Services		



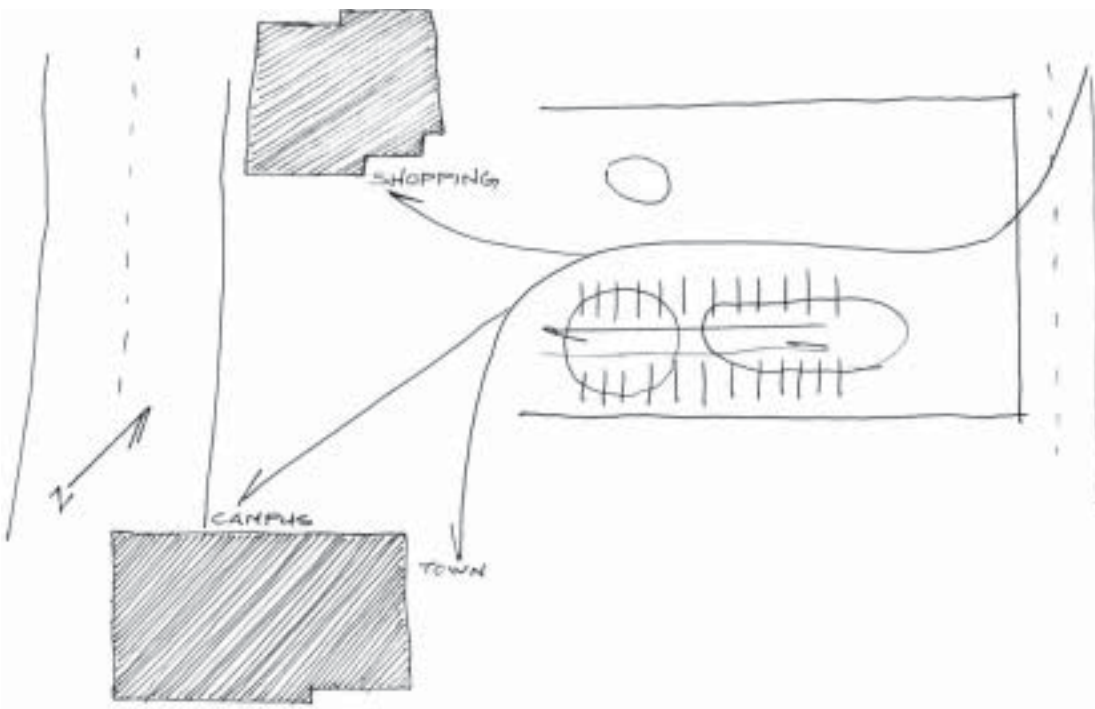
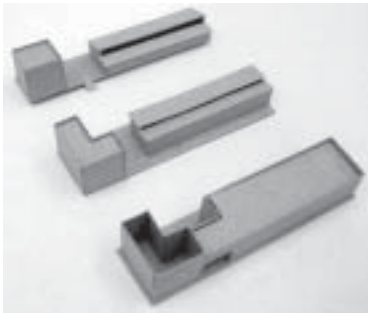

Diagram of informal pedestrian path between Main and Progress Street.



Storm-water Retaining Pond

This proposal seeks to articulate the transition between the two distinct areas of commerce and residence. Therefore the initial program includes both commercial spaces and rental housing. The program had begun with the development of four to five apartments. A new typology proposal for transition uses a commercial space to shield the residential space from Main Street. Mercantile, restaurant, and bar make up the occupancy in the commercial space. The view from the top-floor bar optimizes the sunset. The residential area takes advantage of the benefits of the early morning sun. By keeping the structure slender, a lawn similar to the existing one is maintained. Parking becomes a significant part of the program to support the housing and commercial space. Parking access is located on the Main Street side of the site. Additional parking is on the same level as the existing parking lot, which makes vehicle access possible without a ramp. The existing storm-water retaining pond [pictured far left] is maintained with new articulation. A handicapped accessible public path is introduced to connect Progress Street to the nearby commercial buildings, the alleyway to downtown, and to the Virginia Tech campus.



Commercial/Residential Diagrams

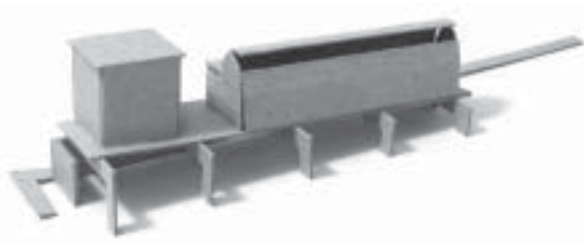

Diagram Model with Parking and Path



Site Plan with Path Diagram

Compiling the components of the program into diagrammatic models results in linear configurations stretching between Progress Street and the parking lot connected to Main Street. In order to conceal parking from view on Progress Street the residential and commercial components are positioned above the parking garage. This massing strategy is employed to limit the size of the proposed building footprint on the site.

Sec. 3052 Site Development Regulations.

(a) Minimum lot Requirements

- (1) Lot area 8500 square feet, except that townhouses and two-family dwellings constructed on an 8500 square foot or larger lot may be divided along the common wall or walls. (Ord. No. 1184, adopted 6-9-98)
- (2) Lot frontage 45 feet

(b) Maximum density: 20 bedrooms per acre, except single-unit residential.

(c) Minimum setback requirements

- (1) Front yard 35 feet (may be reduced to 25 feet for uses with parking in the rear)
- (2) Side yard 10 feet, except on corner lots, a side yard facing the street shall be 20 feet or more
- (3) Rear yard 25 feet

Basic Structure

(d) Maximum height of structures, except church spires, belfries, cupolas, monuments, water towers, chimneys, flues, flag poles, television antennae, and radio aeriels are exempt: 35 feet; or 45 feet with an additional one foot setback per foot of additional height Utility poles may have a maximum height of 45 feet.

(e) Maximum coverage:

(1) Lot coverage 55%

(2) Floor area ratio 0.35 FAR

(f) The maximum dwelling unit occupancy shall be a family, plus two persons unrelated to the family; or no more than three unrelated persons.

(g) All utility lines, electric, telephone, cable television lines, etc., shall be placed underground. (Ord. No. 1215, & 11, 5-11-99)

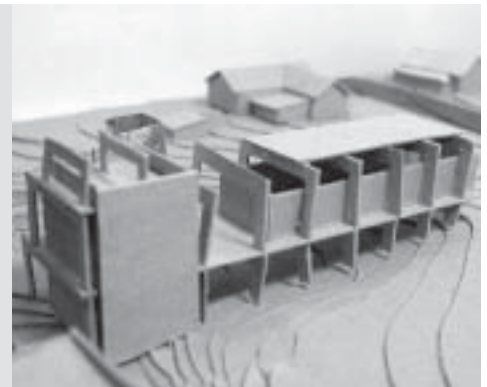

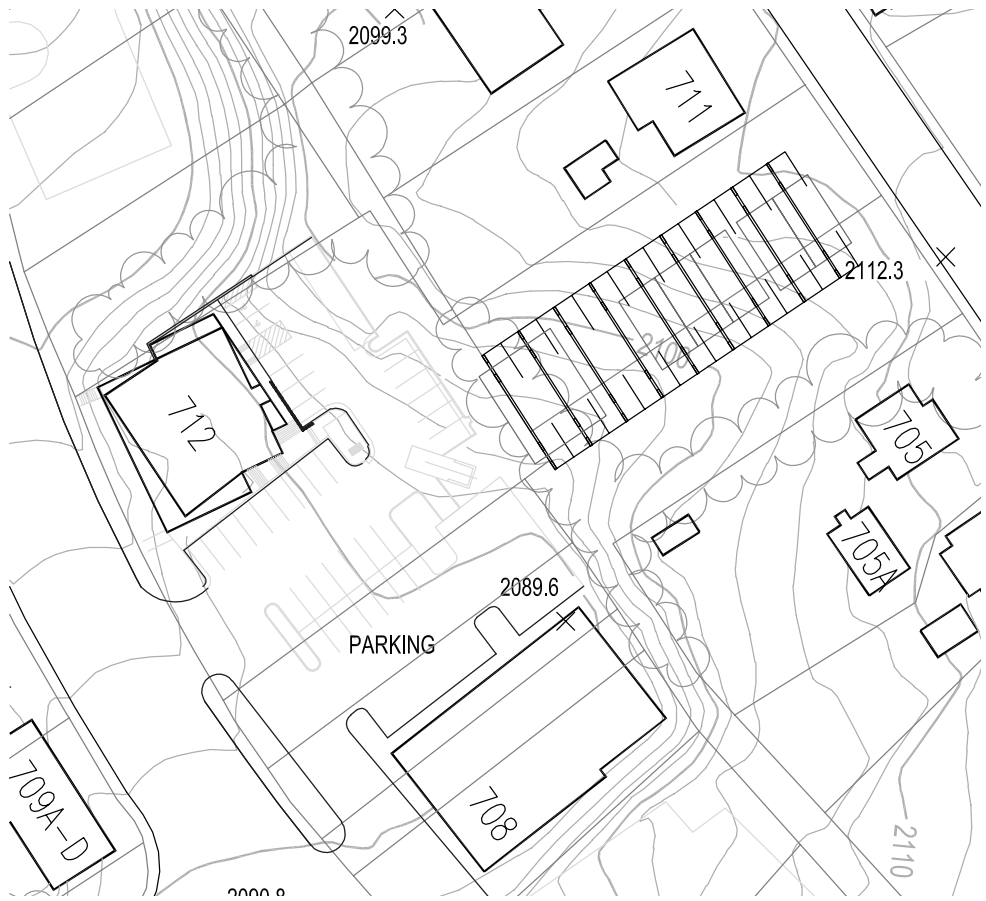

Proposal Footprint on Site

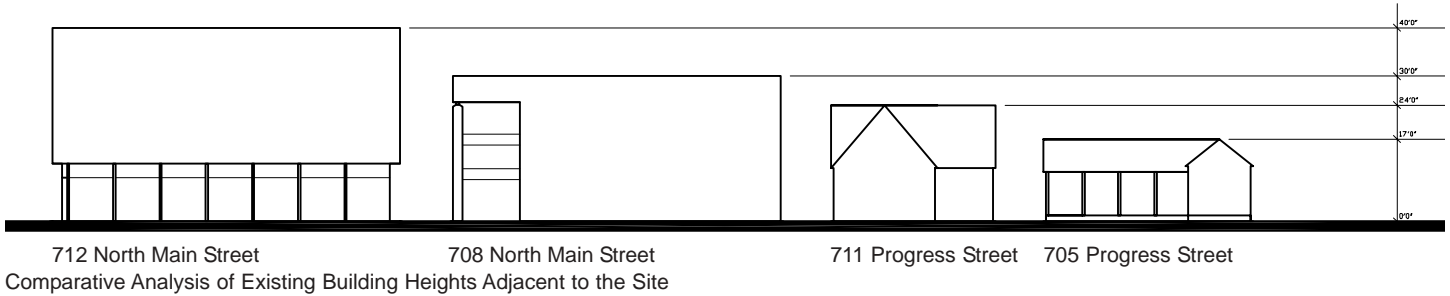

Building proportions change from one and two story houses on Progress Street, to two and three story commercial buildings on Main Street. Likewise the houses have typical pitched roofs, where the commercial buildings' roofs appear flat. Materials for the facades of the houses and buildings in the two zoning districts are wood siding, vinyl siding and brick.

The proposed building responds to the different materials and scales used on the existing commercial and residential buildings. The street face of the housing mass is brick masonry. The facade for the commercial area is concrete block and glass. The concrete masonry unit produces a contrast with the existing brick building facades. The commercial mass is one story above the taller of the existing commercial buildings, 712 N. Main Street. The elevation of the apartment is two stories, common to Progress Street.

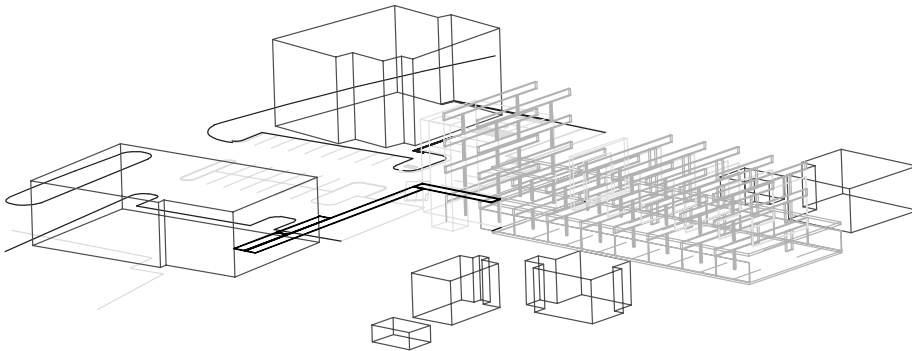

Massing Model

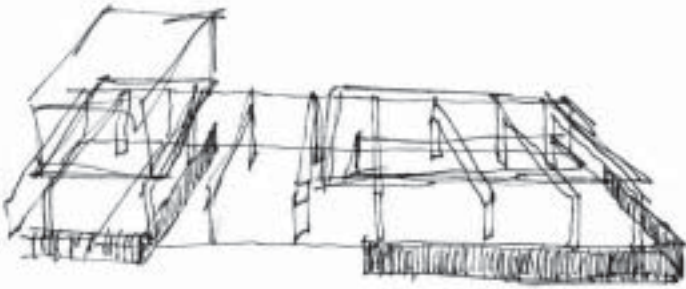
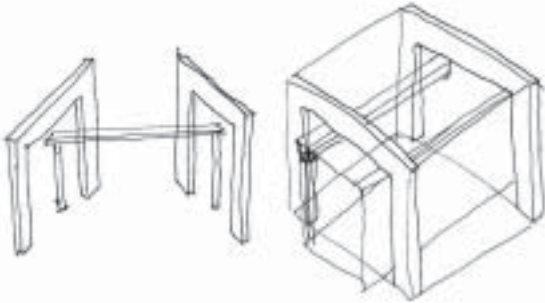
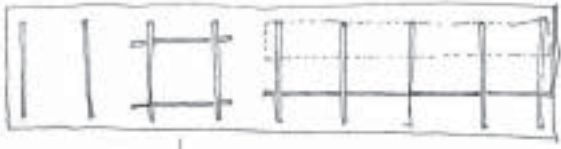
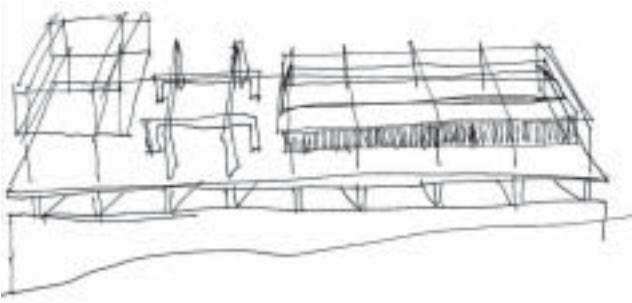

Structure/Infill Sketches



Casa del Fascio, Facade

The structure of the building is the unifying element between the various uses, materials, and scales. Giuseppe Terragni's Casa del Fascio, in Como, Italy [bottom], repeats the structure and reveals the structure on the exterior and interior. Infill between the columns and beams determines the perimeter of the interior spaces. The ordering of the columns and beams is independent of the interior spaces. As in the Casa del Fascio, the repetition of the columns and beams in the proposed building indicates the number of floors. The structure is scaled such that the repeated column element is one story tall, approximately twelve feet. There are volumes that are two stories. However, unlike the case study, the structure within the two story volumes in the proposal will remain at one story increments. The columns and beams of the case study interior [bottom right] shift from the one story increment seen in the facade to a two story increment. The proposal does not make this shift. In all spaces, including the two story vertical spaces of the apartments and mercantile space of the commercial mass, the structural beams repeat at one story increments.



Human to Structure Relationship



Casa del Fascio, Roof



Interior

FRAME RELATIONSHIP

BRICK FALLS IN FRONT

CONCRETE FALLS BEHIND

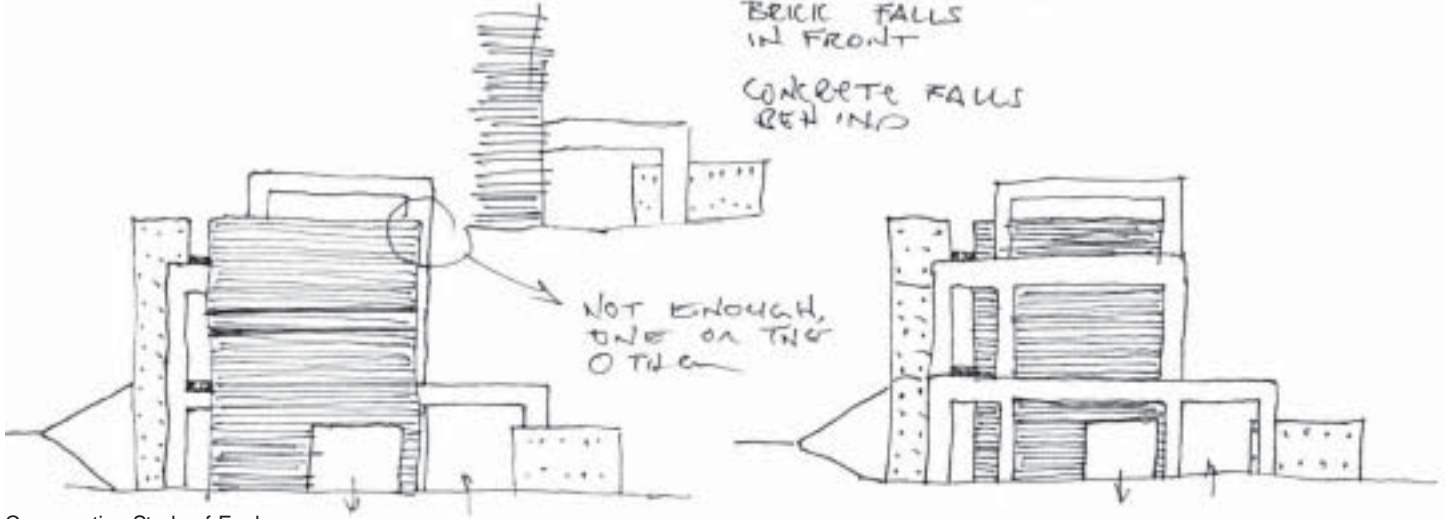

Comparative Study of Enclosure
Overlaid on Structure (left) vs. Infilled Between (right) Structure

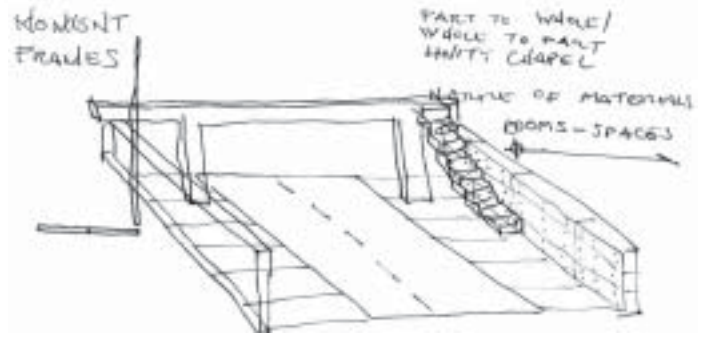
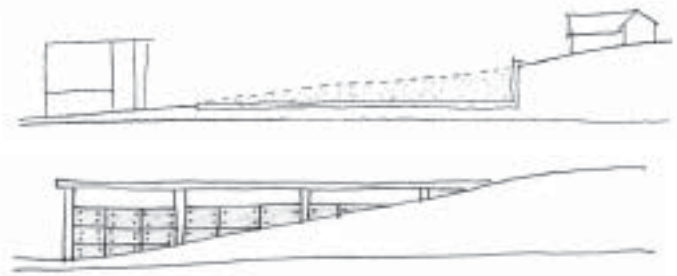

Retaining Wall Study



Vitra Building, Garden Wall



Column Detail



Local Condition

If the structure and infill [top left] are in the same plane with each other they appear as one element instead of two separate functioning elements. To articulate the hierarchy of structure and infill, the end planes of each are pushed apart from one another.

Other case studies for the project are Tadao Ando's Vitra Building [lower left] in Weil, Germany, and Jourda & Perraudin's School of Architecture [lower right] in Lyon, France. In Ando's building, board-formed cast-in-place concrete walls define the perimeter. The proportion for the formwork panels is one to two. Similar walls for the proposal define the parking area as well as conceal it from public view. These walls are formed by wood panels measuring 3 feet in width and 6 feet in length. Concrete walls are frequently cast in place in the Blacksburg area as retaining walls. To make space for the garage, a wedge of earth is removed and the void is leveled, sloping toward Main Street. The retaining walls will hold back the earth outside the parking garage. Cars enter the garage through the existing parking lot at the southwest side of the site.

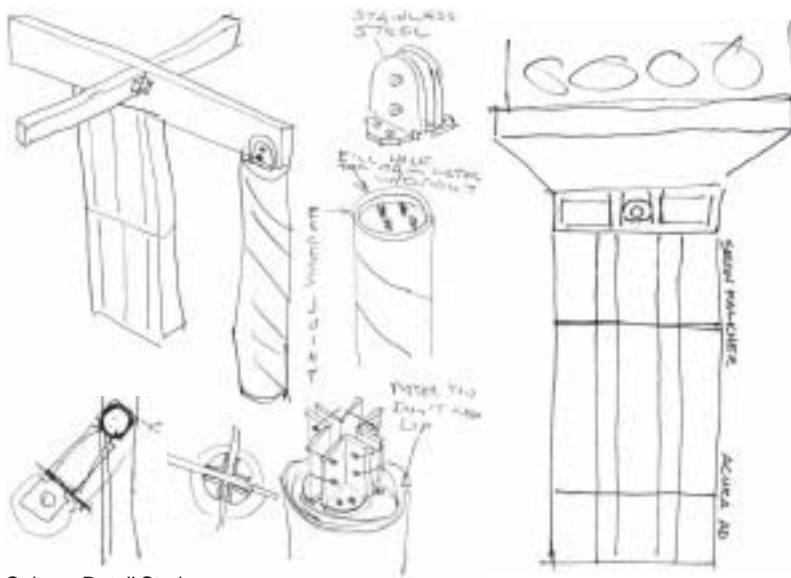

Column Detail Study

Material choices for the proposal, as in the Architecture School, define a heavy base and a light upper structure. In the case of the Architecture School, a wood frame is supported on top of a concrete mass. In the proposed project, a lighter steel structure is carried by the concrete columns and retaining walls of the parking garage. This decision reflects the differences between durability needs in the parking garage and those in the apartments above.

Larger rectilinear columns conceal and protect service pipes and wiring from damage by automobiles. Other sonotube columns perform only structural duty. Because sonotubes are circular in cross-section they are less invasive in a garage where cars maneuver in-between them.



Lyon School, Interior



Material Relationship

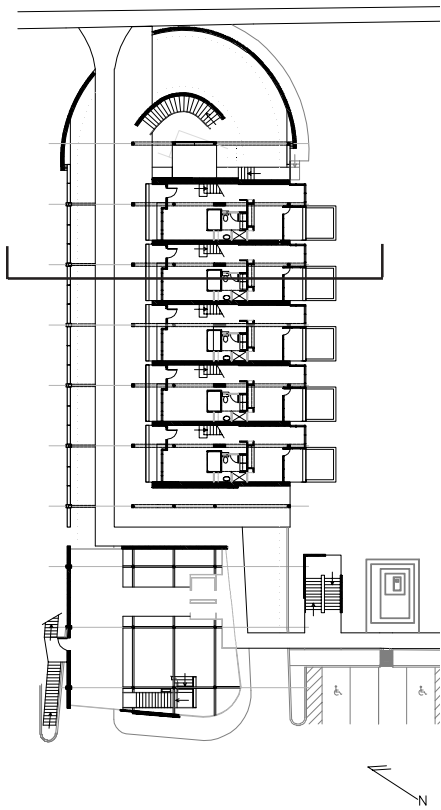

Second Floor Plan

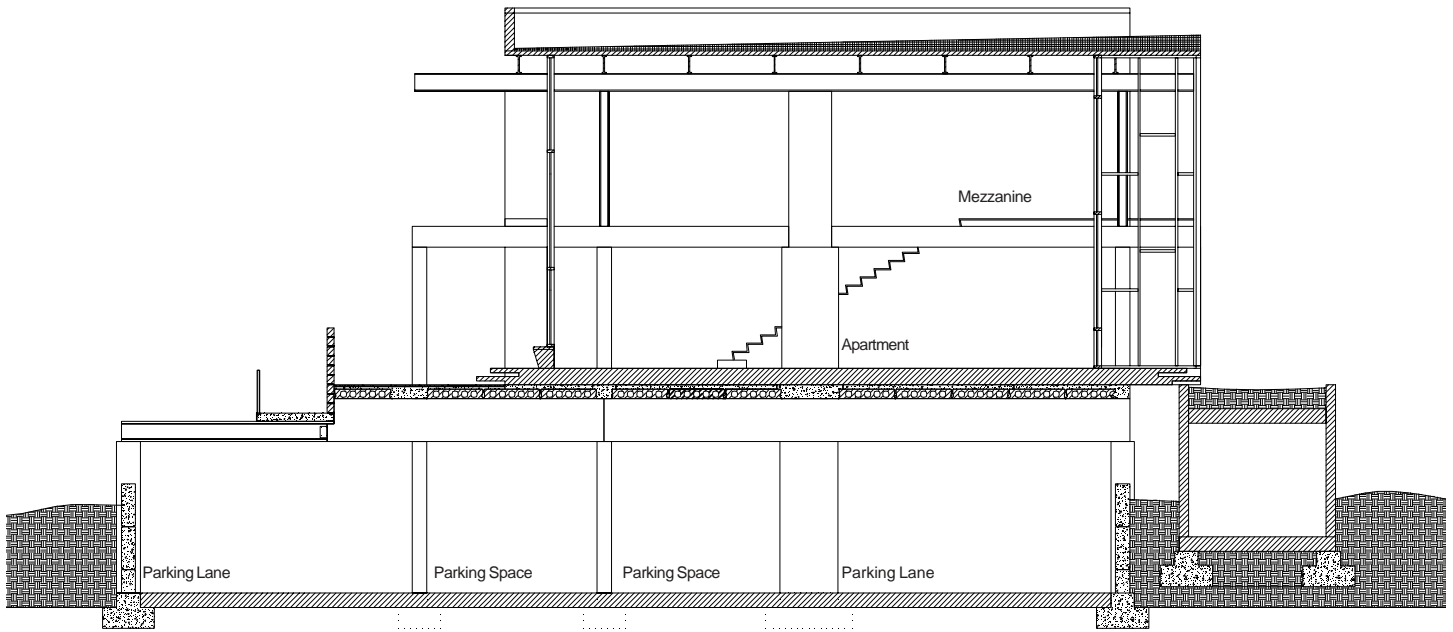

Section Through Garage and Apartment

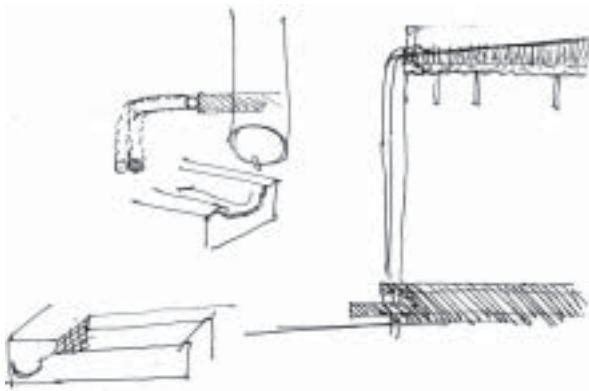

Drainage From Apartment Roof

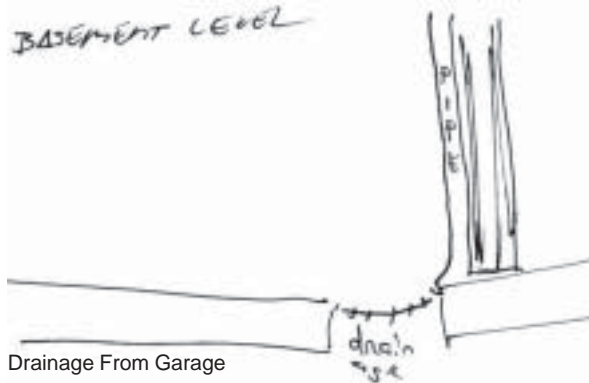

Drainage From Garage

The largest floor area supported by any one column is 352 square feet. Combined over three floors and roof, each column supports no more than 1406 square feet of area. Under normal circumstances, a 12-inch concrete column can support 2000 square feet. Sonotubes which leave residual banding, give the columns form. Concrete beams in the apartment have a depth of 18-inches to span the 23'6" between columns. The concrete beams in the garage are oversized, to 36-inches for extended fire protection from potential car fire. Precast hollow-core slabs span these beams which are set 19'3" on center. The hollow-core slabs are to be 4 feet wide and 8-inches in depth.

In the apartment, steel columns rest on the concrete beams to carry the roof load. The maximum roof area supported by a steel column is 352 feet. W8 columns, which support up to 3000 square feet are selected. The maximum span of the steel beams which run parallel to the concrete beams is 23'6". At 1/20 of span, the beam depth is estimated at 15-inches. The width of the steel beam is half this depth. Steel open-web joists span the steel beams at 19'3". The web joist depth is 1/24 of the span, about 10". Spacing for these roof joists is six feet on center. Corrugated steel roof decking is used to support the components of the roof. Insulation is layered to slope upward at 1/4-inch per foot from the northwest to southeast on the roof. This slope forces water runoff through drains located on the north end of the partition walls. To complete the roof, the roof membrane, base flashing, and ballast are installed respectively.

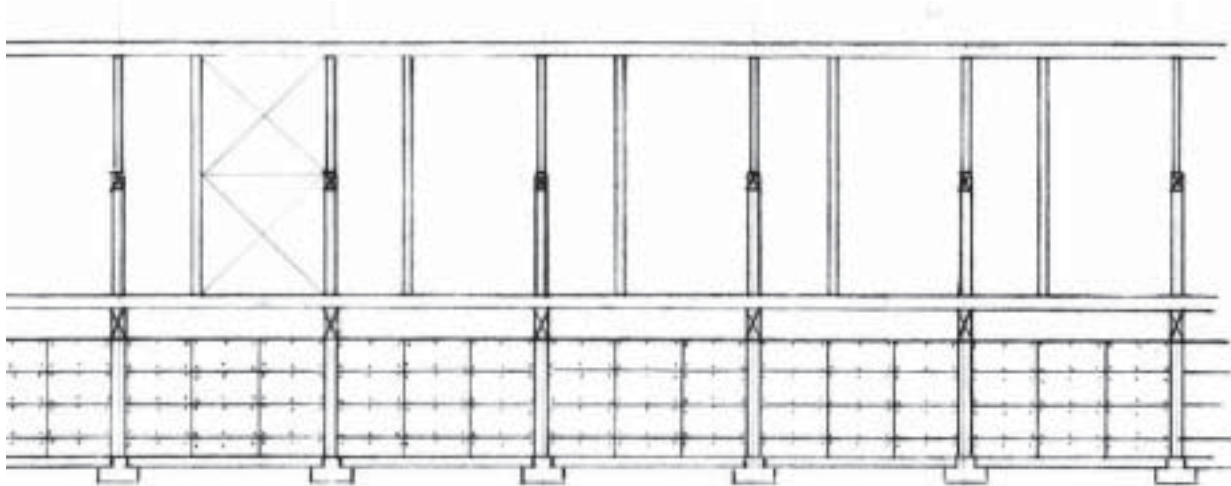

Articulation of Board-formed Retaining Wall

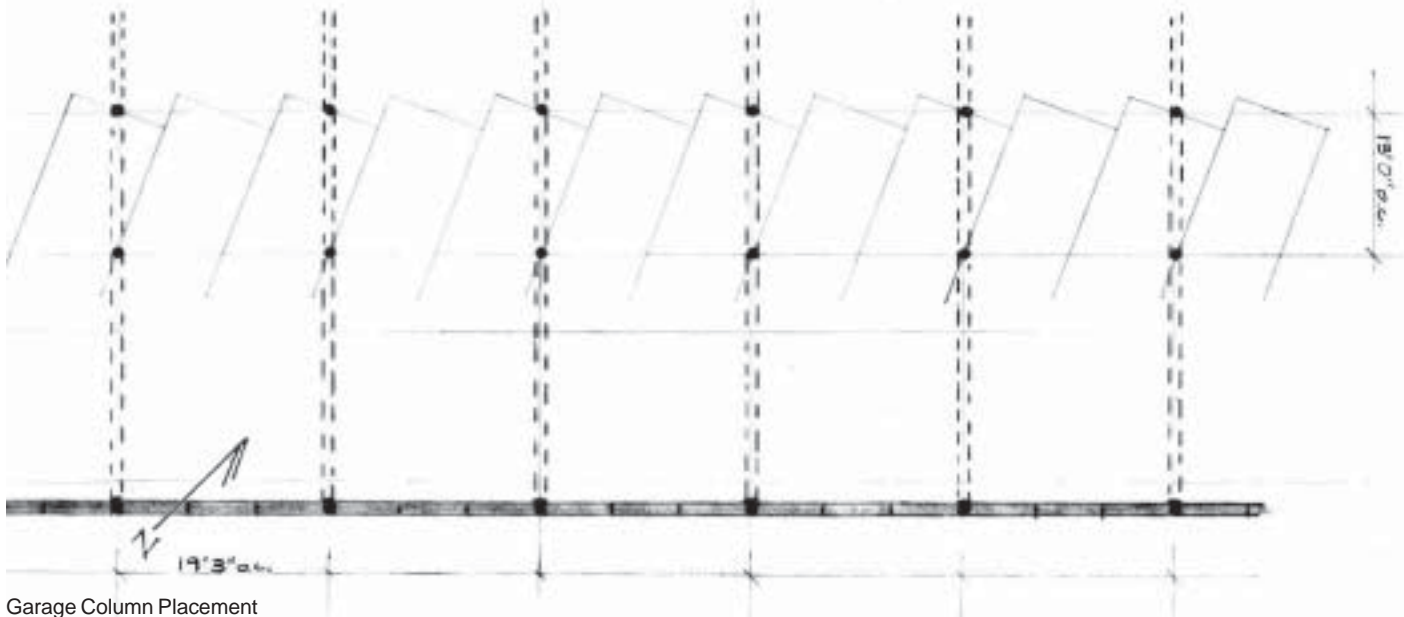

Garage Column Placement

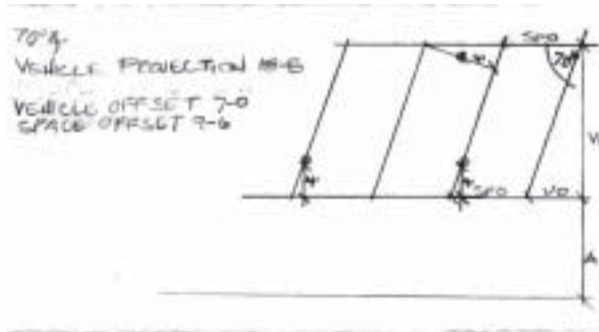

70 Degree Parking Test Parameter

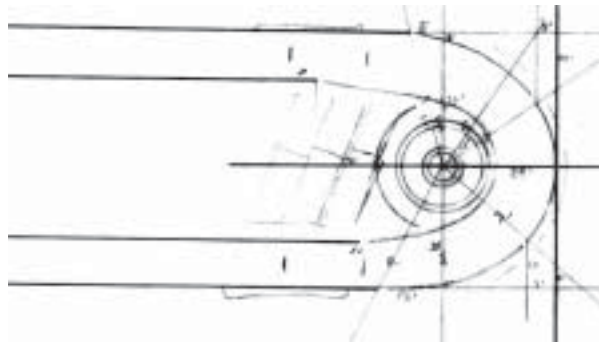

Parking Lane Turning Radius

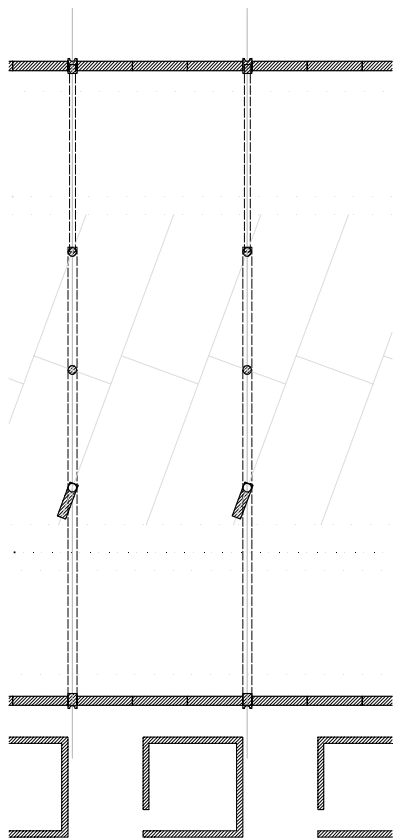

Column Rotation Detail

A full scale parking mock-up [top right] was used to test the relationship of aisle width to angle of parking space. The vehicle used for the test was a Chevrolet, K-5 Blazer, measuring approximately 6'8" wide and 17'8" long. The aisle width was fixed at 12'0". Space width was fixed at 9'0". The angles tested were 60 degree, 70 degree, and 80 degree. The space projections were 18'5", 18'8", and 18'0" respectively. The driver had no difficulty entering and exiting the parking space multiple times at the 60 degree angled space. When parking in the 70 degree angled space, the driver crossed the aisle line opposite the spaces on the first entry into the space. The driver had little difficulty entering and exiting the space multiple times in later attempts. At the 80 degree angled parking, the driver showed little sign of difficulty entering and exiting the space multiple times. The decision was made to widen the lanes in the parking garage to 15'0". Where the lane circles around the end of the spaces [middle right], the lane width increases to 20'0". The radius going into the curve is much sharper than the radius coming out of the curve. The straight lanes, not adjacent to parking spaces, are widened to 13'0".

In order for the columns to straddle the parking space divider lines [lower right], the angle of lines is set at 69.75 degrees. This angle allows columns, 13'0" on center, northwest to southeast, to be placed on center of the lines that delineate spaces. The widths of two parking spaces at 69.75 degree angles determine the column spacing to be 19'3" on center, northeast to southwest. The rectilinear columns in the garage [bottom right] are rotated consistently with the parking lines so that they intrude less into the parking spaces. As a result of column spacing [top left], spacing for the grid between columns on the retaining walls is 18'3". By using 3' X 6' panels as formwork for the walls, it is possible to have 3/4" shadow lines running vertically, as well as horizontally, between the panels and columns.

