

BOOKKEEPING PROCEDURES FOR THE APPLICATION OF THE CONCEPT OF PRE-ALLOCATION OF TOTAL FLOAT

By

Nikhil Ambani

Thesis submitted to the Faculty of Virginia Polytechnic Institute and
State University in partial fulfillment of the requirements for the degree of

Master of Science

In

Civil Engineering

Dr. Jesus M. de la Garza [Chair]

Dr. Michael C. Vorster

Prof. Jim Lefter

Prof. J. K. Lowe

November 5, 2004

Keywords: Pre-Allocation of Total Float, Bookkeeping Procedures, Total Float
Management, Allowable Total Float, Impact Analysis, Allocating
Delay Responsibilities, Start-Finish Database, Allowable Total Float
Database

Copyright © 2004, Nikhil M. Ambani

Bookkeeping Procedures for the Application of the Concept of Pre-Allocation of Total Float

Nikhil Ambani

Abstract

With the increasing complexity in construction projects, monitoring project schedule and managing projects effectively is becoming increasingly important. Most projects being deadline oriented, timely completion becomes a must. Like every industry, the construction industry too lays a lot of emphasis on timely completion which makes it necessary to monitor the project schedule very closely. A schedule overrun is never predicted at the start of the project but during the course of the project, even the slightest change can result in delays.

As per the current scheduling practices, float is considered free. It is an expiring resource and hence the party to the use the float first owns the float. The concept endorsed by the court for analyzing delay claims is the proximate cause concept. As per this concept, the party which is the immediate cause to a particular delay is held responsible for that delay irrespective of what has happened before in the project. Due the ambiguous nature of its interpretation, the present concept on float management has now become one the primary reasons for disputes amongst the participating parties. Parties in contract are always trying to appropriate float to suit their interests. This is why total float management has gained this level of importance in today's industry.

To handle this issue of total float management more efficiently, Dr. Prateapusanond (2003) proposes a new concept of total float management as an effort towards a more fair and equitable system. This concept respects the dynamic nature of construction projects and recognizes float to be an asset for both parties. The new concept proposes to allocate float in the ratio 50:50 between the parties at the start of the project. This pre-allocated float owned by each party is called the Allowable Total Float (ATF). The implementation of this concept ensures that the parties are now aware that

consumption of float in a way that it affects critical activities will expose them potential damages.

This concept is an effort towards a more fair and equitable system for total float management. It appears impressive on paper but its practicality and applicability remains a major concern. This research is aimed at testing the practicality of the proposed concept of pre-allocation of total float. It introduces bookkeeping procedures that will facilitate the application of the concept of Pre-allocation of total float. These procedures have been developed and tested on certain case studies to make sure that they are robust. Once their ability to handle scheduling issues is determined, the bookkeeping procedure along with the concept of pre-allocation of total float is applied to a real construction project. This research presents an in depth analysis of the nature of the proposed concept of pre-allocation of total float, the scheduling issues which this concept does not address to, and certain assumptions which could be used in conjunction with the present concept to make it robust in nature.

Acknowledgements

Graduate studies are a work of many. I would like to thank my parents, for their constant support and inculcating the importance of education in me, without which this work was impossible. I am thankful to my brother for his encouragement and all the lively discussions we've had.

Without proper motivation and advice this would not have been possible. I would like to take this opportunity to thank my academic and research advisor Dr. Jesus M. de la Garza for his valuable guidance through the course of this research. His advice, assistance and jokes have contributed to a most wonderful graduate experience. I would like to express my sincere appreciation to my committee, Dr. Michael Vorster, Prof. Jim Lefter and Prof. J. M. Lowe for their active participation, reviews and valuable comments during the course of this research which helped me refine the scope of my thesis and achieve my goal. Special thanks to Dr. Prateepusanond for having laid the foundation for this research. I am grateful to Mehmet Ozbek and Juan Pinero, who were perfect mentors and extended their fullest help and cooperation.

I would like to thank Branch & Associates, Inc. for their cooperation to facilitate this study. Special thanks to Rick Hall, Wayne Duckett and Bryan Majnich for providing me with the necessary information on regular basis. No amount of thanks is sufficient to thank my friends Priti Ganeshan, Mehul Gandhi, Nikhil Mehra, Rahul Shah, Ritesh Shah, Purva Gokhale and Ujval Gandhi for their constant support, help and providing the much needed distractions.

I am grateful to Virginia Tech and the Vecellio Construction Engineering and Management Program for giving me an opportunity to pursue graduate studies in one of the best institutions in the United States.

Go Hokies!!!

TABLE OF CONTENTS

ABSTRACT	...	ii
ACKNOWLEDGEMENTS	...	iv
TABLE OF CONTENTS	...	v
LIST OF FIGURES	...	vii
LIST OF TABLES	...	ix
CHAPTER 1 – Introduction		
1.1	The Critical Path Method (CPM)	3
1.2	The Current Scenario	4
1.3	The concept of “Pre-Allocation of Total Float” (Prateapusanond 2003)	5
1.3.1	The Delphi Survey	6
	1.3.1.1 Suggestions & Comments	7
1.3.2	Areas of Future Research suggested	8
CHAPTER 2 – Research Objectives & Scope		
2.1	Research Objective	9
2.2	Research Scope	11
CHAPTER 3 – Cases not addressed by the Concept of Pre-Allocation of Total Float		
3.1	Delays to a critical activity (Increase in float)	12
3.2	Delay to non-critical activity, in turn becomes critical	14
3.3	Acceleration to a critical activity (decrease in float)	15
3.4	Acceleration to a non-critical activity (increase in float)	17
3.5	Out of Sequence Progress	18
	3.5.1 Retained Logic	18
	3.5.2 Progress Override	19
3.6	Unethical Scheduling	21
3.7	Rescheduled Activities	23
3.8	Shared Responsibilities	25

TABLE OF CONTENTS (Cont...)

CHAPTER 4 – Applying bookkeeping procedures to factual examples of allocating delay responsibilities

4.1	The Bookkeeping Procedure	26
4.2	Applying concepts to factual examples of allocating delay responsibilities	29
4.2.1	Owner Delay < ATF, Contractor Delay < ATF; Project Delay = 0	30
4.2.2	Owner Delay > ATF, Contractor Delay < ATF; Project Delay = 0	32
4.2.3	Owner Delay =0, Contractor Delay > ATF; Project Delay = 0	34
4.2.4	Owner Delay < ATF, Contractor Delay > ATF; Project Delay = 10 days	36
4.2.5	Owner Delay > ATF, Contractor Delay > ATF; Project Delay = 30 days	38
4.2.6	Considers 2 non-critical paths which eventually become critical	40
4.2.7	Example showing multiple non-critical paths	48

CHAPTER 5 – Applying the concepts to a real construction project

5.1	Alumni Continuing Education Center Hotel Complex: Brief Overview	59
5.2	The As-Planned Schedule	62
5.3	The updating Procedure	63
5.4	The June Update	65
5.5	Insights and Chapter Conclusions	82

CHAPTER 6 – Conclusions and Recommendations

6.1	Conclusions	85
6.2	Areas of Future Research	86

REFERENCES	89
------------	----

APPENDICES

Appendix A	As-Planned Schedule	92
Appendix B	Start-Finish Database for June 2003	112
Appendix C	ATF Database for June 2003	132

LIST OF FIGURES

Figure 3-1.	Section of an As-Planned Schedule for Section 3.1	12
Figure 3-2.	Project Status as of Day 3 for Section 3.1	13
Figure 3-3.	Section of the As-Planned schedule for Section 3.2	14
Figure 3-4.	Project Status as of day 8 for Section 3.2	14
Figure 3-5.	Section of the As-Planned schedule for Section 3.3	15
Figure 3-6.	Project Status as of day 3 for Section 3.3	15
Figure 3-7.	Project Status after applying the new concept for Section 3.3	16
Figure 3-8.	Section of the As-Planned Schedule for Section 3.4	17
Figure 3-9.	Project Status as of Day 2 for Section 3.4	17
Figure 3-10.	Section of the As-Planned Schedule for Section 3.5	18
Figure 3-11.	Schedule status using Retained Logic for Section 3.5	19
Figure 3-12.	Schedule status using Progress Override for Section 3.5	19
Figure 3-13.	Section of an As Planned Schedule for Section 3.6	21
Figure 3-14.	Project Status as of Day 7 for Section 3.6	21
Figure 3-15.	Project Status as of Day 9 for Section 3.6	22
Figure 3-16.	Different version of the Project Status as of Day 7 for Section 3.6	22
Figure 3-17.	Section of an As Planned Schedule for Section 3.7	23
Figure 3-18.	Project Status as of Day 5 for Section 3.7	23
Figure 3-19.	Rescheduled Schedule Update for Section 3.7	24
Figure 4-1.	Section of the As-Planned Schedule for Section 4.1.1	26
Figure 4-2.	Project Status as of April 7, 2004 for Section 4.1.1	27
Figure 4-3.	As-Planned Schedule for Section 4.2.1 (Prateapusanond 2003, pp. 152)	30
Figure 4-4.	As Built Schedule for Section 4.2.1 (Prateapusanond 2003, pp. 153)	30
Figure 4-5.	As Built Schedule for Section 4.2.2 (Prateapusanond 2003, pp. 155)	32
Figure 4-6.	As Built Schedule for Section 4.2.3 (Prateapusanond 2003, pp. 156)	34
Figure 4-7.	As Built Schedule for Section 4.2.4 (Prateapusanond 2003, pp. 159)	36
Figure 4-8.	As Built Schedule for Section 4.2.5 (Prateapusanond 2003, pp. 162)	38
Figure 4-9.	As-Planned Schedule for Section 4.2.6 (Prateapusanond 2003, pp. 164)	40
Figure 4-10.	As Built Schedule for Section 4.2.6 (Prateapusanond 2003, pp. 167)	41
Figure 4-11.	Project Status as of Day 5 for Section 4.2.6	43

LIST OF FIGURES (Cont...)

Figure 4-12.	Project Status as of Day 10 for Section 4.2.6	43
Figure 4-13.	Project Status as of Day 18 for Section 4.2.6	44
Figure 4-14.	Project Status as of Day 19 for Section 4.2.6	46
Figure 4-15.	As Built Schedule for Section 4.2.6 (Prateapusanond 2003, pp. 167)	47
Figure 4-16.	As-Planned Schedule for Section 4.2.7 (Prateapusanond 2003, pp. 169)	48
Figure 4-17.	As Built Schedule for Section 4.2.7 (Prateapusanond 2003, pp. 171)	49
Figure 4-18.	Project Status as of Day 1 for Section 4.2.7	52
Figure 4-19.	Project Status as of Day 3 for Section 4.2.7	52
Figure 4-20.	Project Status as of Day 7 for Section 4.2.7	53
Figure 4-21.	Project Status as of Day 8 for Section 4.2.7	54
Figure 4-22.	Project Status as of Day 10 for Section 4.2.7	55
Figure 4-23.	Project Status as of Day 11 for Section 4.2.7	56
Figure 4-24.	Project Status as of Day 15 for Section 4.2.7	57
Figure 5-1.	Section of As Planned Schedule	66
Figure 5-2.	Section of Update as of April 21, 2003	66
Figure 5-3.	Status as of April 24, 2003	69
Figure 5-4.	Status as of April 25, 2003	70
Figure 5-5.	Project Status before start of activity 82	74
Figure 5-6.	Status after completion of Activity 82	74
Figure 5-7.	Section of the As-Planned schedule	75
Figure 5-8.	Status as of April 25, 2003	77
Figure 5-9.	Status as of April 29, 2003	79

LIST OF TABLES

Table 3-1.	Start-Finish database explaining newly created float (Section 3.1)	13
Table 3-2.	ATF database explaining newly created float (Section 3.1)	13
Table 4-1.	The Start-Finish database for Section 4.1.1	27
Table 4-2.	The ATF database for Section 3.1.1	28
Table 4-3.	Start-Finish database for Section 4.2.1	31
Table 4-4.	ATF database for Section 4.2.1	31
Table 4-5.	Start-Finish database for Section 4.2.2	32
Table 4-6:	ATF database for Section 4.2.2	33
Table 4-7:	Start-Finish database for Section 4.2.3	34
Table 4-8:	ATF database for Section 4.2.3	35
Table 4-9:	Start-Finish database for Section 4.2.4	36
Table 4-10:	ATF database for Section 4.2.4	37
Table 4-11:	Start-Finish database for Section 4.2.5	38
Table 4-12:	ATF database for Section 4.2.5	39
Table 4-13:	Start-Finish database for Section 4.2.6	42
Table 4-14:	ATF database for Section 4.2.6	42
Table 4-15:	Start-Finish database for Section 4.2.7	50
Table 4-16:	ATF database for Section 4.2.7	51
Table 5-1.	Section of Start-Finish database for the activities shown in Figures 5-1, 5-2	67
Table 5-2.	Section of ATF database for the activities shown in Figures 5-1, 5-2	68
Table 5-3.	Section of the Start-Finish database for the activities shown in Figures 5-3, 5-4	72
Table 5-4.	Section of the ATF database for the activities shown in Figures 5-3, 5-4	73

LIST OF TABLES (Cont...)

Table 5-5.	Section of Start-Finish database for activities shown in Figure 5-7	75
Table 5-6.	ATF database for activities shown in Figure 5-7	76
Table 5-7.	Start-Finish database after Activity 1 is delayed	76
Table 5-8.	Start-Finish database as of April 25, 2003	78
Table 5-9.	ATF database as of April 25, 2003	78
Table 5-10.	Start-Finish Database as of April 29, 2003	79
Table 5-11.	Corresponding ATF database as of April 29, 2003	80

Chapter 1

Introduction

Construction projects are becoming increasingly complex and cost intensive, necessitating the need to monitor the project schedule and cost very closely. Construction projects are initiated in complex and dynamic environments resulting in circumstances of high uncertainty and risk, which are compounded by demanding time constraints (Mulholland and Christian 1999). One of the most important issues in planning and executing any construction project is scheduling. The more complex projects are, greater is the need to monitor the project closely since even a slightest miscalculation during the planning phase could result in a major change in the project completion and project cost.

Many projects are deadline oriented and hence timely completion is essential. In the construction sector where conditions are always non-predictive, failure to meet deadlines usually results in either financial penalties or liquidated damages to one or more of the participating parties. On many projects, a schedule overrun does not seem probable at the beginning of the project. Schedule targets are sometimes missed sometimes because of unforeseen events, which even experienced construction managers, could not have anticipated (Mulholland and Christian 1999). However, schedule target dates are more often missed because of events, such as design problems and trade disputes, that were not wholly unforeseeable but their likelihood and effects are difficult to predict with any precision because no two-construction projects are the same (Mulholland and Christian 1999).

Selecting construction methods, scheduling activities and planning the use of the site over time are key to constructing a project efficiently (Zouein and Tommelein 2001). Miscalculation in any of these areas could ultimately also lead to project delays. Scheduling problems may occur whenever there is a choice as to the order in which a number of tasks can be performed using a limited number of resources (Karumanasseri and AbouRizk 2002). Another area, which adds to the present complications in a

construction project, is the number of parties involved. Most general contractors sublet a large percentage of their work to subcontractors for reasons including the need of specialized equipment and expertise, shortage in resources and limitation in finances (Elazouni and Metwally 2000).

Most of these situations cannot be avoided and have to be dealt with, as and when the need arises. However, one area that parties to the contract unquestionably need to concentrate is monitoring the project schedule closely. Scheduling of construction activities becomes the core planning of any construction project. Scheduling becomes necessary, not only for smooth operation, but also for maintaining the quality of construction in case of projects, that are deadline oriented. Scheduling in general involves the following two steps:

1. Identification of all major activities/tasks from start to finish
2. Sequential arrangement of all identified activities/tasks

These two steps help in developing the order of activities and, define the predecessors and successors for each activity.

Owners most always want the project to be completed as soon as possible and hence, failure to meet deadlines usually results in disputes between the participating parties, which more often than not result in financial penalties. Owners and contractors are generally at the risk of incurring additional and substantial costs when construction projects are finished beyond the contractual completion dates (Prateapusanond 2003; Schumacher 1996; Householder and Rutland 1990).

Any delay in the project whether due to natural causes or otherwise is frequently the primary cause of disputes between the participating parties because it is often difficult to determine the party responsible. Thus, it is important to determine the identity of the party responsible when delay occurs. Each day of delay may result in greater monetary losses, to one or more of the contracting parties. These conflicts are sorted out by negotiation, alternative dispute resolution proceedings, or by courts and usually result in further delays and loss of revenue to all parties concerned. Negotiating a fair and timely damage settlement is beneficial to all parties (Bubshait and Cunningham 1998) but, due to many sources and causes of construction delays, it is often difficult to analyze the ultimate liability in delay claims (Kraiem and Diekmann 1987). The construction industry

has a difficult time prospectively identifying with accuracy either the scope or magnitude of change-caused disruption at the activity level (Finke 1998).

Over the years, the industry has seen the use many scheduling practices to analyze the cause of these delays, to allocate responsibility, and thereby allocate responsibility. The Critical Path Method (CPM) is one of the techniques used in delay analysis. The uses of Critical Path Management concepts are valuable in analyzing delays in a claim context. This is primarily because CPM can help to identify the period of the delay event and determine the cause and effect of the delay, as well as pinpoint the responsible parties. (Householder and Rutland 1990; Wickwire et al 1991; Capuano Jr. 1995; Prateapusanond 2003)

1.1 The Critical Path Method (CPM)

The Critical Path Method (CPM) has been widely used as a project management tool to improve scheduling and project administration tasks, supporting project managers to facilitate project completion on time and on budget (Kim 2003). The CPM generates useful information about the project, such as shortest project duration, the critical path(s), and the Total Float (TF) and Free Float (FF) for each activity (Kim 2003). The availability of this information helps project manager's plan and control the project more efficiently. CPM facilitates management by exception (Kim 2003), which means that the managers know which activities are critical and near critical. This information helps them realize which activities need more management attention at that stage of the project. This feature is the one of the principal advantage of the critical path method.

In CPM schedules, activities are scheduled based on their start finish times and their sequence of operations. The main step in scheduling a project using CPM is to define the project and to develop a network by identifying all of the project's significant activities or tasks and the relationships between them. On identifying these relationships, each activity is assigned a cost and resource estimate. Based on these estimates, the activity durations are calculated. The longest time path in the network is computed and this path is known as the critical path.

Using these network characteristics, other information such as the total float of each activity can be calculated. The total float for a particular activity can be defined as the difference between the Late Start date/time and the Early Start date/time or the difference between the Late Finish date/time and the Early Finish date/time for that particular activity. This total float allows for the delays to the non-critical activities in the project. Ponce de Leon (1986) identifies the common scheduling interpretation of “total float” as the number of days an activity may be extended or delayed without delaying the completion date shown in the schedule. Total float can also be identified as a by-product of the critical-path-method calculation (de la Garza et al 1991). It represents the length of time that an activity’s finish date can be delayed without affecting the completion date of the project (de la Garza et al 1991). Using up this total float does not delay the project. Therefore, float usage becomes a key issue in the timely completion of the project.

1.2 The Current Scenario

The concept of total float allocation and ownership employed in construction scheduling over many years has become a major cause for concern, which can result in the potential for delay claims and litigation (Prateapusanond 2003). Disputes over the existence of total float and its ownership are at the core of most delay claims (De La Garza et al 1991). Under current scheduling practices, float time is considered “free” and does not belong to any party in the construction process (Wickwire et al 1991; Prateapusanond 2003). This concept, also endorsed by the courts, treats float as an expiring resource and hence the party to use the float first “owns” the float.

The nature of the present concept, due to its ambiguous nature, has made float ownership a key area of dispute between participating parties. Today’s construction project is a complex effort requiring the support of many design professionals along with a variety of construction talent. The rapid increase in the number of construction disputes in the past few years is startling and would lead one to believe that a construction claim is an inevitable ending for every major project (Wilson 1983). After looking at the increasing numbers of disputes between parties these days, the present concept seems biased towards the participating parties instead of the project; though some may not even

agree with this conclusion. The participating parties more often than not are always trying to appropriate float for their respective benefits. This nature of the present concept suggests the need for an improved concept to allocate float ownership between the participating parties to eliminate or at least minimize the possibility of potential disputes and litigation in the future. The increasing number of court cases in the recent past necessitates the need to come up with an entirely new set of scheduling specifications for float ownership in the contract documents. With every passing day, the need of developing an entirely new concept for analyzing delays and allocating float ownership is becoming stronger.

1.3 The Concept of “Pre-Allocation of Total Float” (Prateapusanond 2003)

Due to the ambiguous nature of its interpretation, float ownership has become one of the key areas of dispute between the participating parties. As per the current scheduling practices, float is an expiring resource and the party to use the float first owns the float. Prateapusanond (2003) proposes a new concept for total float management as an effort towards a more fair and equitable system for float allocation. This concept respects the dynamic nature of construction projects and hence recognizes total float to be an asset for both parties and hence for the project as a whole. Hence, the risk of unforeseen circumstances is shared equally between the participating parties.

The ambiguous nature of float ownership can be clarified by improving contract language with regard to scheduling specifications in the area of total float management (Prateapusanond 2003). The overall purpose of such research was to introduce a comprehensive practice of float pre-allocation and management terms for the application of scheduling specifications in the CPM based construction contract (Prateapusanond 2003).

The new concept proposes to pre-allocate a set amount of total float to participating parties on the same non-critical path. This pre-allocated float owned by each party before the start of the project is the Allowable Total Float (ATF). Allocating the

respective ATF values to each party ensures that the parties are now aware that any consumption of float in a way that affects the critical activities and hence delays project completion will expose them to potential damages.

For the sake of equity, the study proposes allocating the float equally (i.e. 50:50) between the participating parties. For the successful application of the concept, Prateapusanond (2003) also recommends the application of the “No Damage for Non-Critical Delay” clause, which would ensure that the parties are not exposed to damages until the delay is critical and affects project completion.

1.3.1 The Delphi Survey

As an effort to validate the proposed concept, Prateapusanond (2003) conducted a survey seeking opinions from industry professionals on the proposed concept. Some of the key findings of this survey are as given below:

- Total Float ownership and management has become a major source of conflict between participating parties whenever a delay occurs
- 50% of the panel members do not believe in the efficiency and feasibility of the present concept
- The proposed concept:
 - can significantly increase awareness that float consumption can play a role in creating potential project delays
 - can significantly resolve the total float ownership issue
 - is not costly to implement

There was a little concern amongst the panel members on the ease of implementation of the proposed concept. The major rationale of those who disagree with the proposed concept is due to the dynamic nature and complexity of construction schedules (Prateapusanond 2003).

1.3.1.1 Suggestions and Recommendations:

There were a number of observations and suggestions made by the panel members as listed below:

- The proposed concept is much fairer to the parties of a contract
- Some of the panel members believe the concept is not workable and will not respect the dynamic nature of construction schedules
- Scheduling issues and contractors' "scheduling games" should be addressed concurrently but separately with the proposed concept
- Some suggest the methodology should address the additional total float issues arising from the owners' change orders and contractors' actions
- The implementation of this concept would lead to higher bids to cover for contingencies
- It will be difficult to compute total float on monthly basis
- The acceptance of the proposed concept would require complete rethinking of an already accepted float ownership principle
- The proposed concept should be tried on a real project
- The 50:50 ratio should be reconsidered; higher float for the contractor will ensure contractor ingenuity

Overall, the results showed that most of the panel members agree with the proposed concept and believe the concept of total float pre-allocation would significantly increase the awareness of total float consumption by the two parties and resolve the total float ownership issue (Prateapusanond 2003)

1.3.2 Areas of Future Research as suggested by Prateapusanond (2003)

Although the concept has been shown to increase the awareness of total float utilization, one cannot know whether the concept is practical (Prateapusanond 2003). The author recommends the following areas for future research:

- Apply the concept on a real project to see if it is capable of handling scheduling problems which occur during construction
- Develop a criteria to determine the amount of float assigned to each party
- Develop contract clauses for scheduling changes which occur during a project
- Create a computer program or enhance a present scheduling program to keep track of the amount of float used and the amount remaining for each party during the course of the project

Chapter 2

Research Objectives & Scope

Over the past few years, the construction industry has seen a rapid increase in the number of disputes. The proposed concept of “Pre-Allocation of Total Float” is an effort towards a more fair and equitable system of float allocation. As discussed in Chapter 1, the concept is impressive on paper, but its practicality and applicability still remains a major concern amongst construction professionals. This research is aimed at testing the practicality of this concept and to see whether the concept is applicable to complex construction projects.

2.1 Research Objective

The proposed concept of “Pre-Allocation of Total Float” is appealing on paper and appears to solve the present problem of total float management, but the biggest challenge is to determine how to apply this concept on a real construction project effectively. A real project will involve a lot more complexities than the ones on which the concept has been based upon, and hence this would help us determine if this concept is applicable practically.

The first area of future research articulated by Prateapusanond (2003) while introducing the concept of “Pre-Allocation of Total Float” can be quoted as:

“To test the practicality of this concept, it should be implemented in a real construction project. Although the concept of total float is successfully developed in this research, it might not solve all other scheduling problems that occur during construction”

(Prateapusanond 2003, pp. 214)

This research is an extension of Dr. Prateapusanond's research and concentrates on the above-mentioned area. The main aim of this study is to develop bookkeeping procedures to keep track of the ATF owned by the parties, namely, the owner and the contractor, at the start of the project and then keep track of the amount of total float used by individual parties and the corresponding remaining ATF during the course of the project. The study will also show how to apply these bookkeeping procedures for the successful application of the proposed concept of "Pre-Allocation of Total Float." The methodology adopted can be broadly divided into three parts:

1. Introducing the bookkeeping procedures

This section will explain the logic used in developing the bookkeeping procedures. It concentrates on explaining how to read what the tables depict and then uses an example to show how these tables could be used to keep track of the total float for each activity.

2. Testing these bookkeeping procedures on the examples considered by Dr. Prateapusanond to validate the proposed concept

The bookkeeping procedures explained in the previous section might appear to be very basic and hence their capability to monitor complex projects like the Alumni Continuing Education Center Hotel Complex (ACECHC) is questionable. To validate the developed bookkeeping procedures and before applying them straight on the complex ACECHC schedule, these have been applied to the factual examples developed by Dr. Prateapusanond, which are relatively less complex in nature. This section addresses the application of the bookkeeping procedures to these examples as a test to determine how they actually serve their purpose.

3. Applying these developed concepts to a real construction project

Once the competence of the developed bookkeeping procedures with the factual examples is confirmed, they have been applied to the 993-activity ACECHC schedule. This section addresses two areas. Firstly, it shows how the proposed concept can be applied to an actual construction project schedule and hence the first area of future research articulated in Dr. Prateapusanond's study. Secondly, it also tests the competence of the bookkeeping procedures developed on complex project schedules.

2.2 Research Scope

The scope of this research is restricted to developing bookkeeping procedures, which would help keep track of the ATF for the respective parties, and to show how these bookkeeping procedures could actually be used to apply the proposed concept of “Pre-Allocation of Total Float”.

As predicted in the survey, the proposed concept does not address all the situations that are likely to occur during an actual, real-life construction project. During the course of this research, a number of such areas were identified. This research will highlight each situation in detail and present an example of the corresponding situation from the ACECHC schedule.

The successful application of any concept requires it to be fool-proof in nature. To continue with its application, necessary assumptions were made at each stage. The study will highlight the scheduling problem, present a real life example, explain the necessary assumptions, and show how the assumptions add value to the proposed concept. The decisions taken at each stage are merely assumptions and hence can vary from person to person. While going through this research it is very important to visualize the schedule. This research uses Fenced Bar Charts (Mellin and Whiteaker 1991) as a visualization tool. Hence, this research also addresses concern for scheduling problems and scheduling games.

Chapter 3

Cases not addressed by the concept of Pre-Allocation of Total Float

The basic rationale behind this research is to test the practicality and the applicability of the proposed concept of Pre-Allocation of Total Float. As previously predicted, the concept did not address all possible scheduling situations. While applying the concept to the ACECHC project schedule, a number of these areas were identified. Each of these areas is dealt with individually. To continue with the successful application of the proposed concept, assumptions were made as a solution to each of these problems. It should be noted that the solutions adopted are merely assumptions and hence can vary with a different perspective.

3.1 Delays to a Critical Activity (Increase in Float)

This situation occurs very often in an actual construction project. Consider the following example:

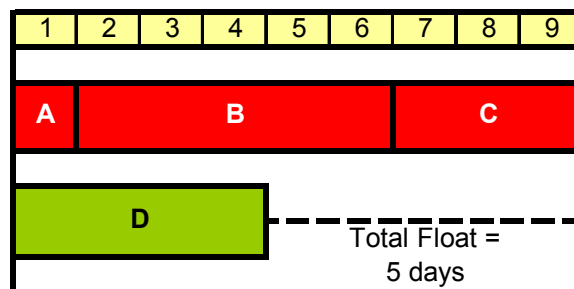

Figure 3-1. Section of an As-Planned Schedule

As illustrated in Figure 3-1, activities A, B, and C are critical, whereas activity D has a float of 5 days. As the project progresses, Activity A is delayed by 2 days. This

delays the project completion by 2 days and as a result, the float of activity D becomes 7 days.

The project status as of day 3 is as shown in the Figure 3-2.

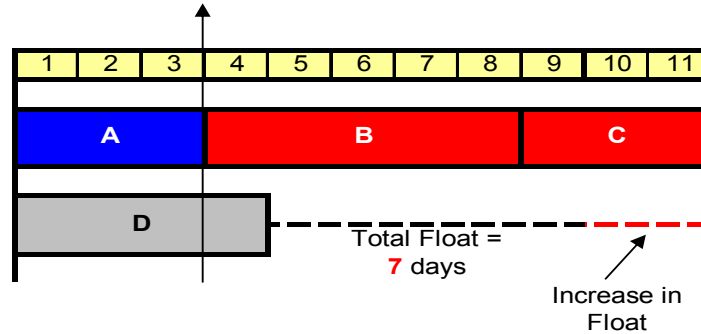

Figure 3-2. Project Status as of Day 3

This delay to a critical activity creates “newly created float” for activity D. The proposed concept does not consider this “newly created float” and hence it cannot be successfully applied unless it addresses this issue. Therefore, to apply the subject concept and to test the capability of the bookkeeping procedures developed, an assumption is made. For the purpose of this research, this newly created float is considered similar to the previously existing float. The same concept of equal allocation is applied again and hence this newly created float is distributed equally between the parties to the contract.

The Start – Finish database for the above example is as shown in Table 3-1.

Table 3-1. Start-Finish database explaining newly created float

ID	As Planned			Day 3		
	Start	Finish	TF	Start	Finish	TF
A	0	1	0	0	3	
B	1	6	0	3	8	0
C	6	9	0	8	11	0
D	0	4	5	0	4	7

The corresponding ATF database is as shown in Table 3-2.

Table 3-2. ATF database explaining newly created float

ID	As Planned			Day 3		
	TF	Owner	KR	TF	Owner	KR
A	0	0	0	0	0	0
B	0	0	0	0	0	0
C	0	0	0	0	0	0
D	5	2.5	2.5	7	3.5	3.5

3.2 Delay to a Non-Critical Activity, In turn becomes critical

Consider the schedule shown in Figure 3-3.

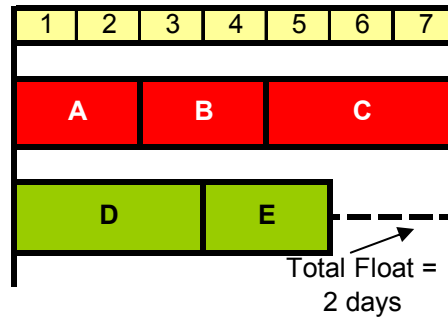

Figure 3-3. Section of the As-Planned Schedule

During the course of the project, activities A and B are completed as per schedule. The completion of activity D is delayed by 4 days. The status is as shown in the figure 3-4.

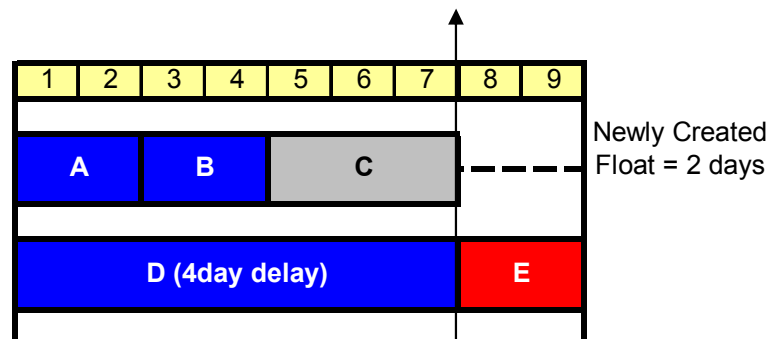

Figure 3-4. Project Status as of day 8

Initially activity C was critical, but due to the 4-day delay to activity D, is now no longer critical and has a float of 2 days. The concept does not consider the creation of any newly created float and to proceed with this application this situation must be addressed. This situation is similar to the situation discussed in 3.1, except that the delay is caused to a previously non-critical activity instead of a previous critical activity. This situation would be considered as another example of newly created float and this newly created float would be treated in the same way as 3.1 and hence would be distributed equally between the parties.

3.3 Acceleration to Critical Activity (Decrease in float)

Another situation, which occurs many times in construction projects, is acceleration. Consider the schedule as shown in the figure 3-5.

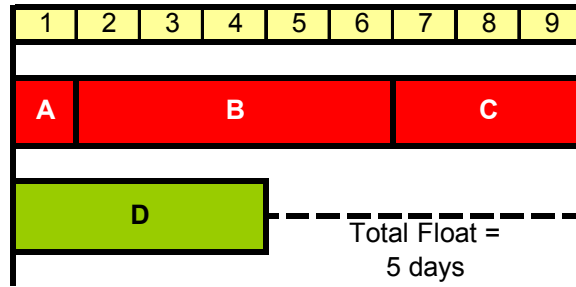

Figure 3-5. Section of the As-Planned Schedule

During the course of the project, activity B is accelerated. The completion of activity B is reduced to 2 days instead of the scheduled 5 days. This eventually decreases the float for activity D from 5 days to 2 days. The project status as of day 3 is as shown in figure 3-6.

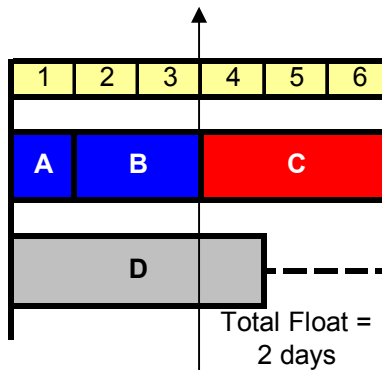

Figure 3-6. Project Status as of day 3

This situation has not been addressed by the concept of “Pre-Allocation of Total Float” and it was found to occur on more than one occasion when the ACECHC project was delayed due to weather and change orders. To continue with the successful application of this concept it was necessary to address this issue. Therefore, it was decided that the decrease in total float for the affected activities would be the deducted from the ATF of the party causing the acceleration. Nevertheless, to provide the party an incentive for the acceleration, the respective party is awarded an overall critical float of 3

days at the end of the project. This means that if this party delays the project completion sometime later during the course of the project by a period of three days or less, it is not penalized, unless the specifications are changed at the next contemporaneous update and the parties involved agree otherwise. “Critical Float” could be defined as the number of days the completion of the project could be delayed by a specific party without being penalized. It should be noted that only the responsible party could use this float. Therefore, the overall float for the non-critical activity will remain the same, but the calculations will show a reduction in the ATF value for the respective party for activity D. After considering this assumption, the project status would look as shown in Figure 3-11.

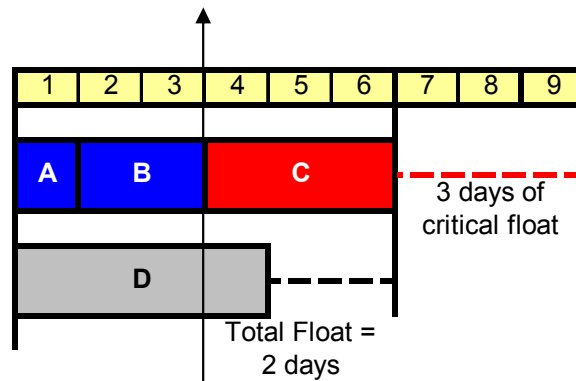

Figure 3-7. Project Status after applying the new concept

3.4 Acceleration to a non-critical activity (increase in float)

Acceleration is almost always in the best interests of the project. Another situation not addressed by the proposed concept is acceleration to a non-critical activity. Consider the following example:

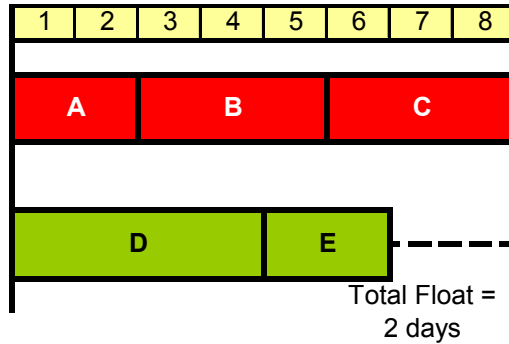

Figure 3-8. Section of the As-Planned Schedule

During the course of the project, activity D was accelerated to complete in 2 days. Completion of activity A was as per schedule. The status on day 2 is as shown in figure 3-9.

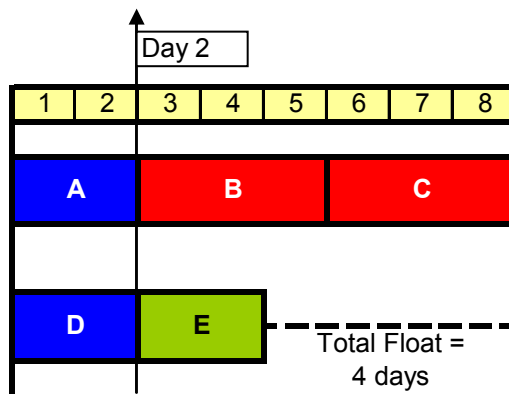

Figure 3-9. Project Status as of Day 2

An acceleration to activity D leads to newly created float for activity E. In such a situation it was assumed that this newly created float would be treated in the same way as it was treated in 3.1 and hence this additional 2 days of float for activity E would be divided equally between the parties.

3.5 Out of Sequence Progress

Until this point, we have considered examples in which the activities are completed in the order they were sequenced at the start of the project. Another situation, which is seen very often in a construction project, is out of sequence work. Consider the section of a schedule as shown in Figure 3-10.

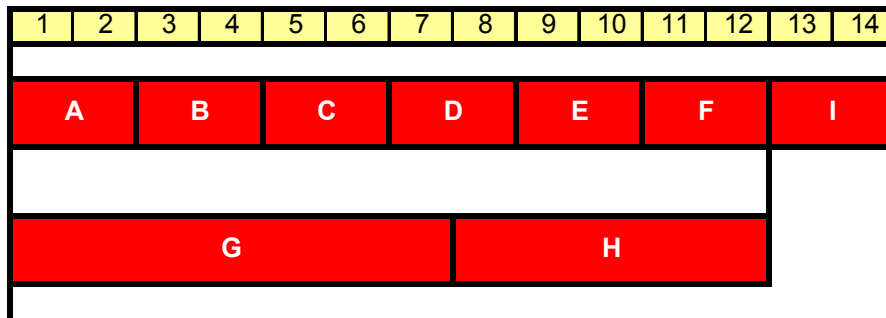

Figure 3-10. Section of the As-Planned Schedule

During the course of the project, activity C is completed before the start of activities A and B. Hence, it can be said that activity C is out of sequence. In the case of out of sequence work, the project schedule can be updated in two ways: using retained logic or progress override.

3.5.1 Retained Logic

When the project schedule is updated using the retained logic, activity C would be considered as a zero duration activity once it is completed. Therefore, the sequence of operations will remain the same and activity D will not start until activities A and B have completed (unless activity D is also completed out of sequence). The project schedule now would be as shown in figure 3-11.

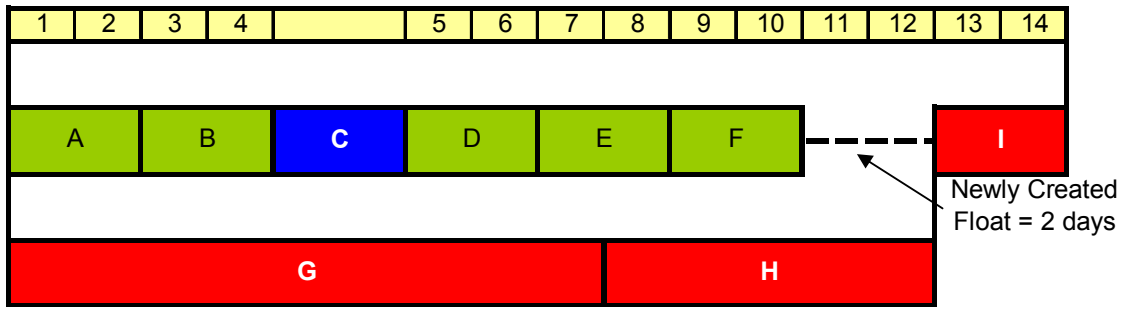

Figure 3-11. Schedule status using Retained Logic

The early completion of activity C makes activities A, B, D, E, and F non-critical. These activities now share a total float of 2 days. This is another example of newly created float and this would be dealt with in the same way as in 3.1. The schedule shown in the figure 3-11 shows how activities are updated using the concept of retained logic.

3.5.2 Progress Override

The other method adopted for scheduling out of sequence progress is using progress override. In this case, as soon as activity C starts before its preceding activities, these preceding activities no longer share the same path. The early start of activity C breaks the finish to start link between activities B and C. Hence, activities A and B are now no longer the predecessors for activities D, E, and F. Since there is no finish-start link between B and C, activities A and B no longer have a successor and are now linked to the last activity i.e. activity I in this case. This in turn makes them non-critical. The schedule is as shown in figure 3-12.

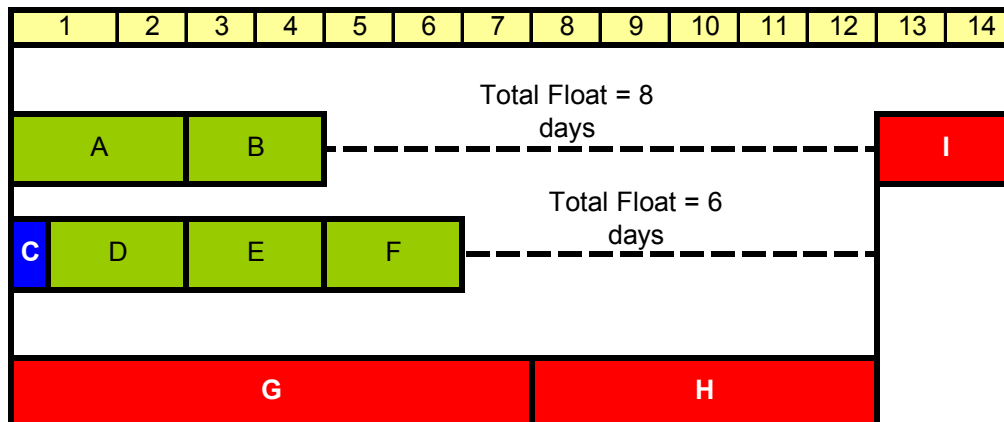

Figure 3-12. Schedule status using Progress Override for 3.5

In this case, the critical path breaks into two non-critical paths. Both paths have newly created float of 8 days and 6 days, respectively, and this float would be treated in the same way as 3.1.

The decision on which concept should be used to schedule out of sequence work is a management level decision. Usually, most contractors are not aware of which concept they wish to follow and hence the choice depends on the scheduling software used. Branch & Associates use Microsoft Project® for scheduling, which in turn uses the concept of progress override. Several cases were observed when the activities in the ACECHC project were completed out of sequence, which led to a sudden increase in the total float value of its preceding activities. This was because the project schedule was updated using progress override. The proposed concept does not address this issue of out of sequence progress. Since most of the time out of sequence progress leads to newly created float, some may just consider this issue to be another variation of the newly created float concept discussed in 3.1.

3.6 Unethical Scheduling

In these situations, the contractor manipulates the schedule in order to meet the needs of the project. Consider the example shown in Figure 3-19.

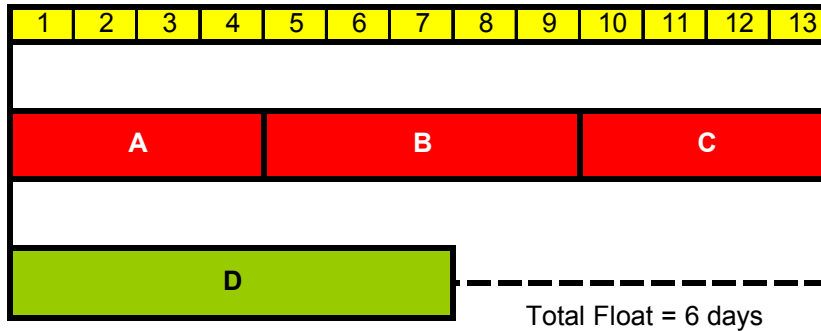

Figure 3-13. Section of an As Planned Schedule

The project status as of day 7 is as shown in figure 3-14.

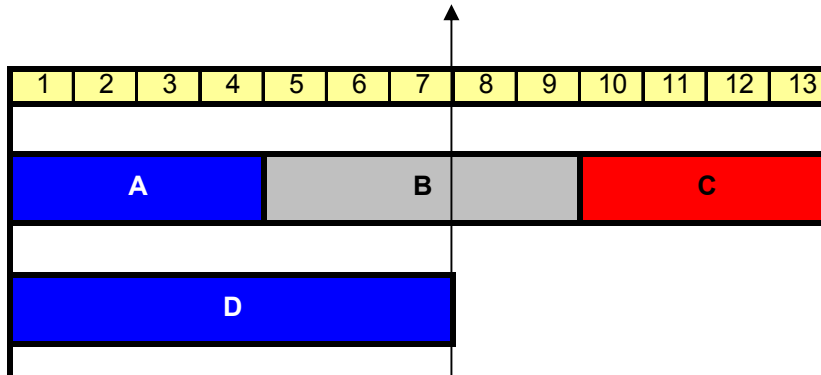

Figure 3-14. Project Status as of Day 7

As of day 7, activities A and D are completed as per schedule. Nevertheless, activity B has not even started. Eventually though, when the update on day 9 was carried out, Activity B is shown to complete as per schedule. Hence, the actual start for activity B is day 4 and the actual finish is day 9. The project status as of day 9 is as shown in figure 3-15.

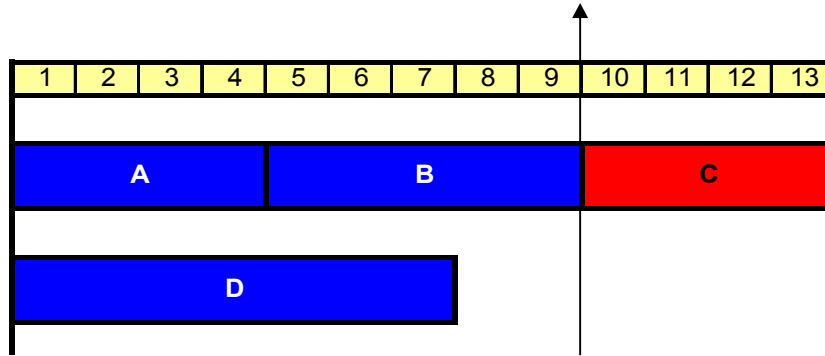

Figure 3-15. Project Status as of Day 9

The successful application of the proposed concept of “Pre-Allocation of Total Float” requires one to monitor the schedule closely. Hence, each intricate detail should be shown by the schedule as and when it occurs or else it might affect the process of monitoring the ATF values for each party. To explain this further, assume that activity B instead of being completed as per schedule was completed out of sequence. Consider the update as shown in Figure 3-16.

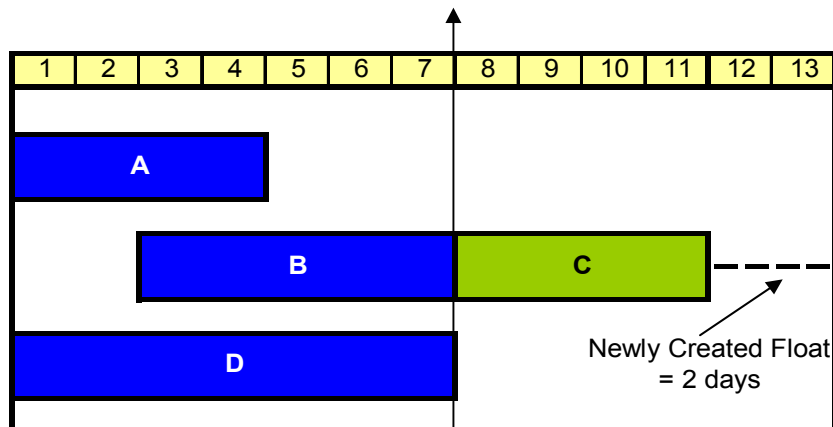

Figure 3-16. Different version of the Project Status as of Day 7

Instead of the status shown in Figure 3-15, had the update been as of Figure 3-16, becomes important to note the actual start date. The out of sequence progress for activity B due to its early start will affect the corresponding start and finish dates of all its successor activities. In complex schedules like the ACECHC project schedule, where one activity might be related to a number of other activities, the sooner one records any change in activity progress, the better it will be to monitor the progress of the successor activities.

3.7 Rescheduled Activities

When schedule updates are performed, not all activities are addressed to. Only the activities that have already started or have been completed are shown while updating. The activities that have not been performed at all are not reflected in the schedule updates. If the information of these activities is not made current, then the schedule gives a false impression of the present status. Consider the following example:

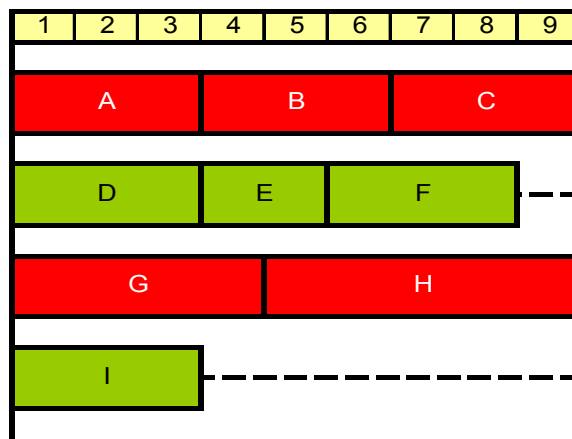

Figure 3-17. Section of an As Planned Schedule

It was decided to update this project at an interval of every 5 days. The project status as of day 5 is as shown in figure 3-18.

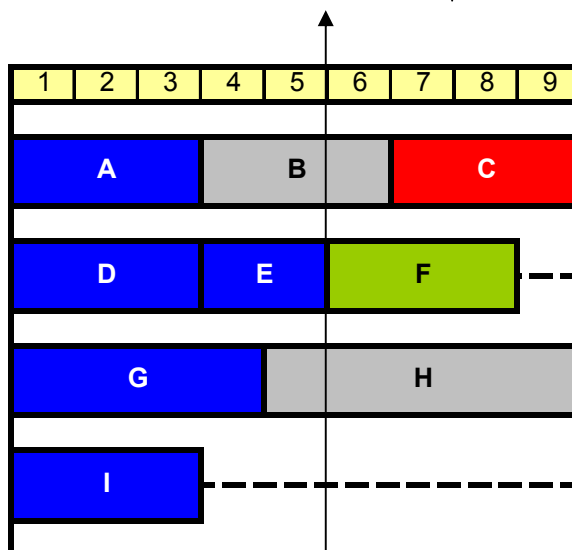

Figure 3-18. Project Status as of Day 5

As shown in Figure 3-18, activities B and H have not yet started. Even though the project status is day 5, these activities still have start and finish dates, which are the same as the As-Planned Schedule. To reflect the status of the project, these activities should be updated in such a way that they should start after day 5. The current project schedule would like:

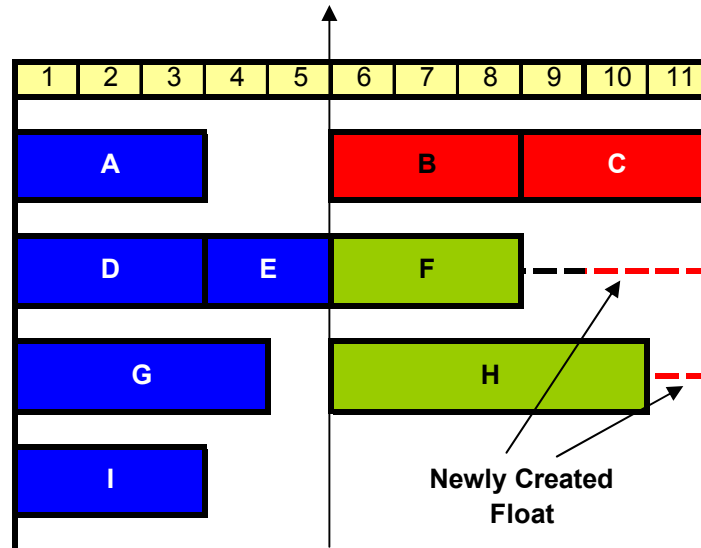

Figure 3-19. Rescheduled Schedule Update

This rescheduling of non-completed activities to start after the project status date will change the activity characteristics, i.e., their start and finish dates, and will result in a change in the total float values of many other activities in the schedule. This concept of rescheduling the updates has been adopted during the course of this research. The concept of “Pre-Allocation of Total Float” does not address this issue. To apply this concept successfully, another assumption needs to be made.

For the purpose of this research, each rescheduled update was treated as an As Planned Schedule for the next update. Any increase in total float value was distributed equally amongst the parties. Nevertheless, if there were a decrease in the total float value due to the activity being rescheduled, then the party responsible to complete that particular activity would be held responsible.

3.8 Shared Responsibility

The concept of “Pre-Allocation of Total Float” proposes to allocate the risk equally amongst parties and hence is a reasonable effort towards a more equitable system. Nevertheless, the concept assumes that any delay to an activity will be either a contractor delay or an owner delay. In construction, sometimes activities can be a responsibility of both the parties involved. For example, in the ACECHC project schedule, activity 993, i.e., SUBSTANTIAL COMPLETION, would be the responsibility of both parties. In cases such as these where it becomes difficult to allocate responsibility, the proposed concept does not hold true.

An assumption, for delays to shared responsibility activities, is to hold both the parties responsible and hence in case of any delay to such activities, the delay would be split equally and each party would see a decrease in its ATF value for the corresponding delay.

Chapter 4

Applying bookkeeping procedures to factual examples of allocating delay responsibilities

Dr. Prateapusanond proposed the concept of “Pre-Allocation of Total Float” as an effort towards a more fair and equitable system for float allocation (Prateapusanond 2003). The application of this concept would require both parties to the contract to monitor the schedule very closely.

4.1 The bookkeeping procedure

Monitoring the schedule in such detail would likely require maintaining two databases (Depending on their ability to deal with complex data, some may consider combining the two databases into a single database also). The first database records the start and the finish dates of each activity in the schedule, whereas the second database keeps track of the ATF value for each of the corresponding activities. Let us consider an example to see what the databases actually would do.

4.1.1 Example explaining the function of each database

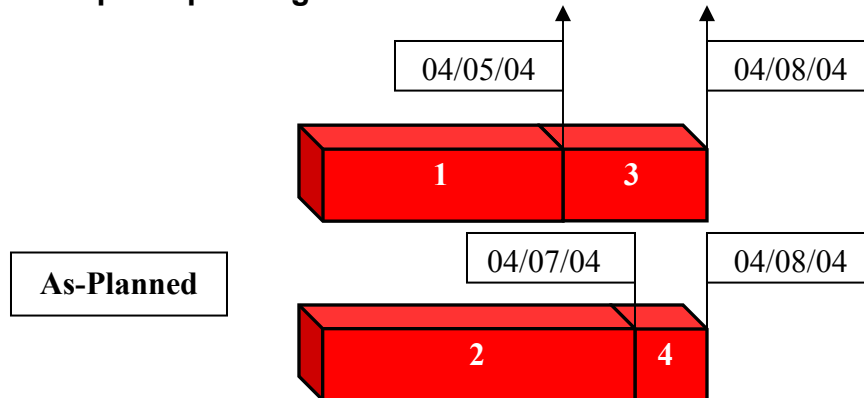

Figure 4-1. Section of the As-Planned Schedule

Figure 4-1 shows a section of the As-Planned Schedule wherein, both the paths are critical. The contemporaneous update carried out as of April 7, 2004, is as shown in Figure 4-2.

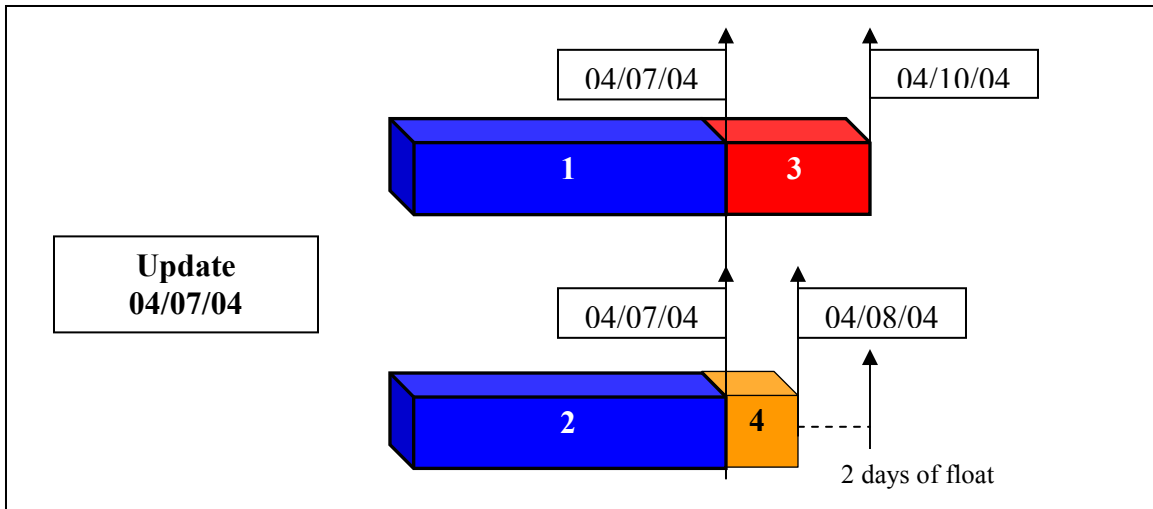

Figure 4-2. Project Status as of April 7, 2004

The activities shown in **red** are critical non-completed activities. Activities in **blue** are the completed activities [100% complete] and activities in **yellow** show the non-critical non-completed activities. The number shown in each bar is the activity ID and the dates shown in the respective flags are the respective completion or expected completion dates.

Table 4-1 shows the database that keeps track of the start and finish dates of each activity, and the total float associated with it. For the rest of the discussion to follow this database will be referred to as the “Start-Finish database.”

Table 4-1. Start-Finish database

ID	As Planned			Update 1 [April 7, 2004]		
	Start	Finish	TF	Start	Finish	TF
1	4/1/2004	4/5/2004	0	4/1/2004	4/7/2004	
2	4/1/2004	4/7/2004	0	4/1/2004	4/7/2004	
3	4/6/2004	4/8/2004	0	4/8/2004	4/10/2004	0
4	4/8/2004	4/8/2004	0	4/8/2004	4/10/2004	2

The dates showed in bold represent the completed activities (shown in blue in Figure 4-2). The values highlighted in yellow represent a change from the previous value. In the given example, there is a delay in the completion of activity 1, now scheduled to complete on April 7, 2004. This delays the start and hence the finish of activity 3. Since all these values have changed when compared to the initial baseline, these are highlighted in the database shown in Table 4-1. Due to this delay, activity 4 is no longer critical and has a float of 2 days. Hence, there is a change in the float value of activity 4, which is also highlighted. In this example, the first set of Start, Finish, and Total Float (TF) values are for the initial As-Planned Schedule. The next set of values is for Update 1 (the contemporaneous update carried out on April 7, 2004). As and when the project status is updated, this current table is appended with a new set of values. This helps the user to know the exact status of the project on each update and hence makes it easier to determine the cause of any change in the schedule.

The second database created keeps track of the Allowable Total Float. For the rest of the discussion this database will be referred to as the “ATF database” and is as shown in Table 4-2:

Table 4-2. ATF database

ID	As Planned			Update 1 [April 7, 2004]		
	TF	Owner	KR	TF	Owner	KR
1	0	0	0	0	0	0
2	0	0	0	0	0	0
3	0	0	0	0	0	0
4	0	0	0	2	1	1

The total float allocation database helps one to monitor the allowable total float values owned by both parties for every activity in the schedule. It also highlights any change in the value of the total float when compared to its previous update. This helps the user see any change in the total float value of one particular activity through a series of updates. Hence, this database keeps track of the total float for each activity and the allowable total float for that respective activity owned by the parties to the contract. Considering the same example, in the As-Planned Schedule, all the activities were critical

and hence the float associated with each activity is zero. The allowable total float for both parties too would be zero. On the first update carried out on April 7, 2004, activity 1 is delayed which in turn delays activity 3. Activity 4 is no longer critical and now has a float of 2 days. This change in float value is highlighted in the database. The zero values highlighted in grey depict completed activities.

These procedures may seem to appear very basic from the above explanation and hence their capability in keeping track of complex projects like the ACECHC project (993-activity schedule) is questionable.

To check whether these basic procedures comply with the complexity in a real project, they have been applied to the factual examples developed by Dr. Prateapusanond to explain the new concept of Pre-Allocation of Total Float. Once they were used for the case studies successfully, the same procedures were be used to monitor the ACECHC project schedule.

4.2 Applying concepts to factual examples of allocating delay responsibilities

To check whether these basic bookkeeping procedures are applicable to varying situations seen in the construction industry, these are first applied to the factual examples created by Prateapusanond (2003). The cases cover a variety of different scenarios in which delay can occur and how this delay can be allocated.

4.2.1 Owner delay < ATF, Contractor delay < ATF; Project Delay = 0

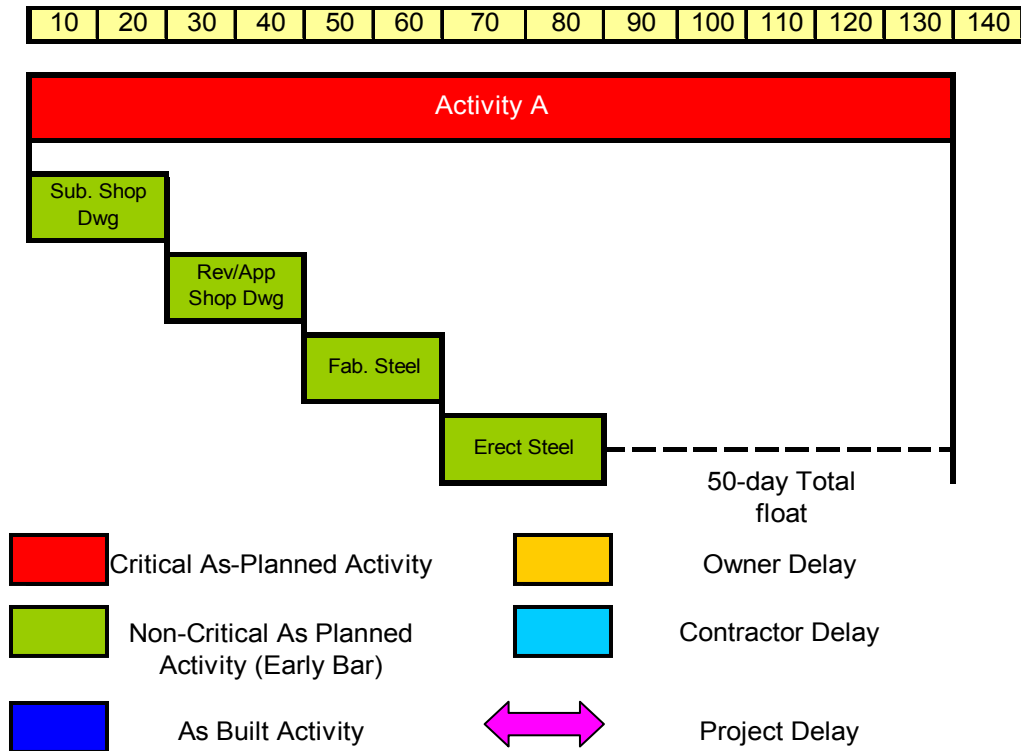
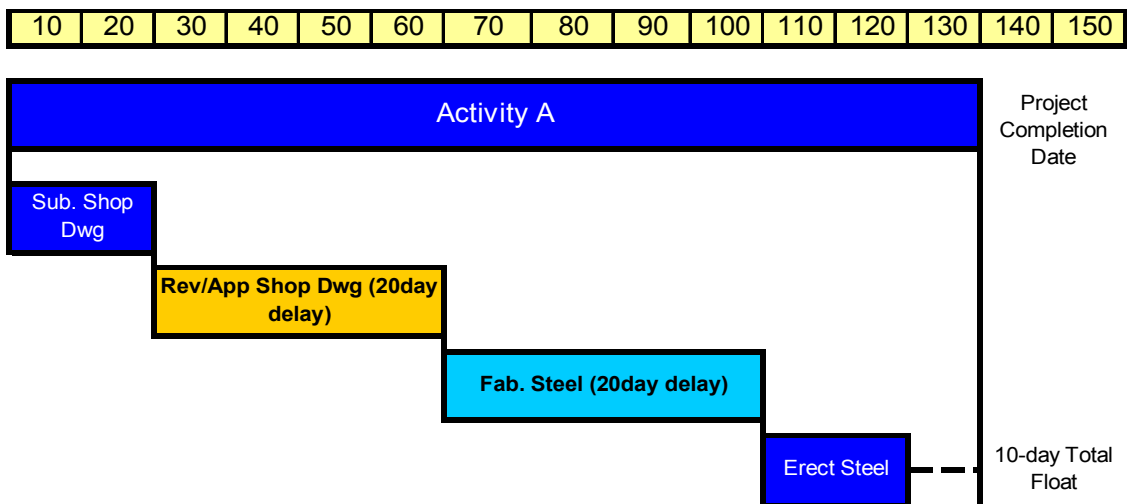

Figure 4-3. As-Planned Schedule (Prateapusanond 2003, pp. 152)



The owner delays in reviewing steel shop drawings for 20 days and the contractor later delays the steel fabrication for 20 days. The project completion date remains unchanged. Under this situation, the owner and the contractor do not have to respond for any delay because the amount of their accumulated delays does not affect the project completion date.

Figure 4-4. As Built Schedule (Prateapusanond 2003, pp. 153)

In this example, Figure 4-3 represents the As-Planned Schedule and Figure 4-4 represents the As Built Schedule. Let us assume that the activities in the non-critical path were all of 20-day duration and activity A has 130-day duration. Since these examples were not developed with respect to dates, we shall consider the Start of the project as “day 0” and hence the project completion is “day 130.” The Start-Finish database for this example is as shown in Table 4-3.

Table 4-3. Start-Finish database

ID	As Planned			Update1 [Day 20]			Update2 [Day 60]			Update3 [Day 100]			Update4 [Day120]			As Built		
	Start	Finish	TF	Start	Finish	TF	Start	Finish	TF	Start	Finish	TF	Start	Finish	TF	Start	Finish	TF
Activity A	0	130	0	0	130	0	0	130	0	0	130	0	0	130	0	0	130	
Sub. Shop Dwg	0	20	50	0	20		0	20		0	20		0	20		0	20	
Rev/App Shop Dwg	20	40	50	20	40	50	20	60		20	60		20	60		20	60	
Fab. Steel	40	60	50	40	60	50	60	80	30	60	100		60	100		60	100	
Erect Steel	60	80	50	60	80	50	80	100	30	100	120	10	100	120		100	120	

While carrying out the contemporaneous updates, any changes with respect to the previous update in the start/finish dates or total float values are highlighted in yellow. This helps the user monitor the schedule in detail and predict at the end of every stage which party was responsible for a delay to the project completion or an acceleration. The numbers showed in **bold** represents the completed activity.

The corresponding ATF database for this example is as shown in Table 4-4.

Table 4-4. ATF database

ID	As Planned			Update1 [Day 20]			Update2 [Day 60]			Update3 [Day 100]			Update4 [Day120]			As Built		
	TF	Owner	KR	TF	Owner	KR	TF	Owner	KR	TF	Owner	KR	TF	Owner	KR	TF	Owner	KR
Activity A	0	0	0	0	0	0	0	0	0	0	0	0	0	0	0	0	0	0
Sub. Shop Dwg	50	25	25	0	0	0	0	0	0	0	0	0	0	0	0	0	0	0
Rev/App Shop Dwg	50	25	25	50	25	25	0	5	25	0	0	0	0	0	0	0	0	0
Fab. Steel	50	25	25	50	25	25	30	5	25	0	5	5	0	0	0	0	0	0
Erect Steel	50	25	25	50	25	25	30	5	25	10	5	5	0	5	5	0	0	0
							20 day Owner delay			20 day Contractor delay								

Since the number of days used by each party is less than the ATF owned by the parties, the parties are not penalized for these delays.

4.2.2 Owner delay > ATF, Contractor delay < ATF; Project Delay = 0

Consider the same As Planned Schedule as shown in the previous example. This example considers a delay in which the owner uses more float than the ATF value. As shown in the figure 4-5, there is a 30-day owner delay followed by a 10-day contractor delay.

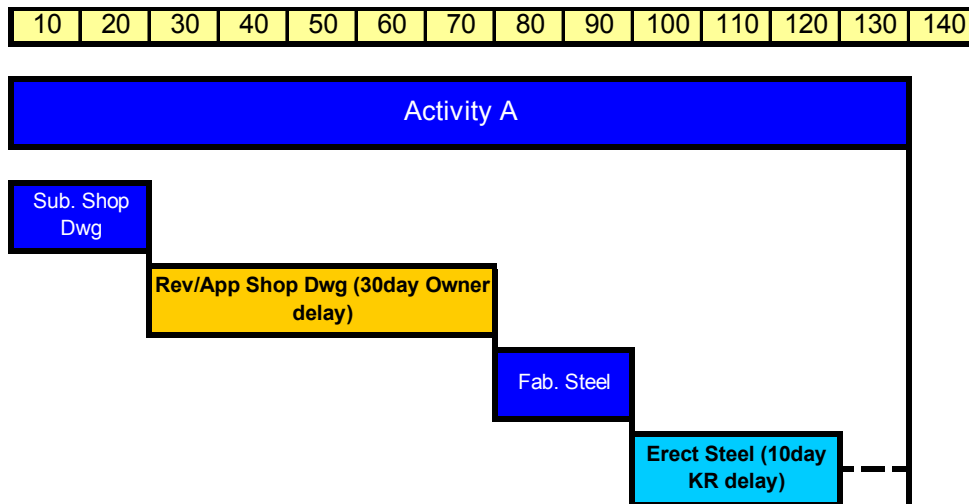

The owner delays the review of steel shop drawings for 30 days and later the contractor later delays the erection of steel for 10 days. An accumulation of total float consumption on the steel activity path is 40 days, which does not have an effect on the project completion date. The owner and the contractor in this case do not have to respond for any delay.

Figure 4-5. As Built Schedule (Prateapusanond 2003, pp. 155)

The Start-Finish Database for this example is shown in Table 4-5.

Table 4-5. Start-Finish database

ID	As Planned			Day 20			Day 70			Day 90			Day 120			As Built [day 130]		
	Start	Finish	TF	Start	Finish	TF	Start	Finish	TF	Start	Finish	TF	Start	Finish	TF	Start	Finish	TF
Activity A	0	130	0	0	130	0	0	130	0	0	130	0	0	130	0	0	130	
Sub. Shop Dwg	0	20	50	0	20		0	20		0	20		0	20		0	20	
Rev/App Shop Dwg	20	40	50	20	40	50	20	70		20	70		20	70		20	70	
Fab. Steel	40	60	50	40	60	50	70	90	20	70	90		70	90		70	90	
Erect Steel	60	80	50	60	80	50	90	110	20	90	110	20	90	120		90	120	

The corresponding ATF database is shown in Table 4-6.

Table 4-6: ATF database

ID	As Planned			Day 20			Day 70			Day 90			Day 120			As Built [day 130]		
	TF	Owner	KR	TF	Owner	KR	TF	Owner	KR	TF	Owner	KR	TF	Owner	KR	TF	Owner	KR
Activity A	0	0	0	0	0	0	0	0	0	0	0	0	0	0	0	0	0	0
Sub. Shop Dwg	50	25	25	0	0	0	0	0	0	0	0	0	0	0	0	0	0	0
Rev/App Shop Dwg	50	25	25	50	25	25	0	-5	25	0	0	0	0	0	0	0	0	0
Fab. Steel	50	25	25	50	25	25	20	-5	25	0	-5	25	0	0	0	0	0	0
Erect Steel	50	25	25	50	25	25	20	-5	25	20	-5	25	0	-5	15	0	0	0
							30 day Owner delay						10 day Contractor delay					

In this case the “-5” value in the owner’s column shows that the owner has used 5 days more than his allowable limit (ATF value = 25). Since the contractor has just used 10 days out of his 25 days, the remaining ATF of 15 days owned by the contractor compensates for the extra 5 days used by the owner. There is no delay to the project completion and hence none of the parties is penalized for the delay. Had there been a delay to the project completion due to the delays, then the owner would have been penalized for having used 5 days more than his allowable limit.

4.2.3 Owner delay = 0, Contractor delay > ATF; Project Delay = 0

In this case, the contractor first causes a 20-day delay, which is followed by another contractor responsible delay of 30 days. The As Built Schedule is as shown Figure 4-6.

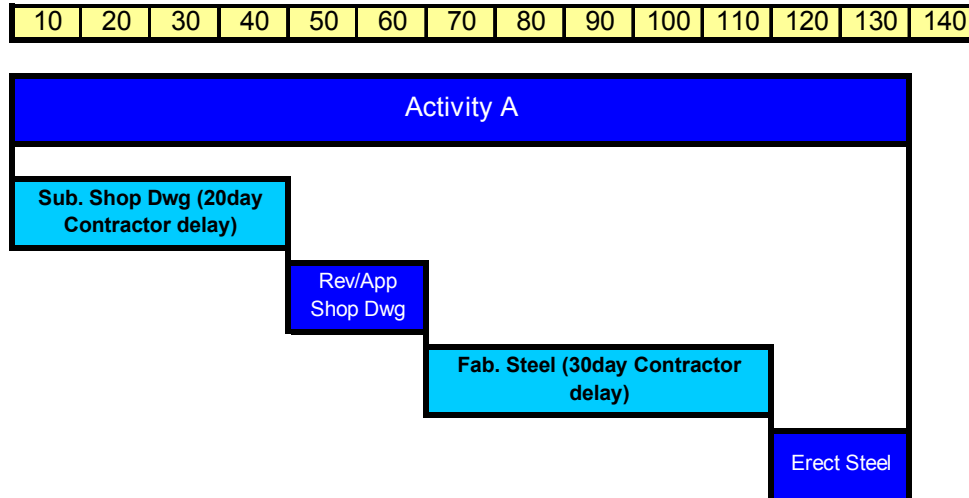

The contractor delays the submission of steel shop drawings for 20 days and later delays the steel fabrication for 30 days. In sum, the contractor consumes float times of the steel activities for 50 days. In this situation, the contractor does not have to respond for any delay because the accumulation of the contractor's delays does not affect the project completion date or the consumptions of total float does not exceed the total float.

Figure 4-6. As Built Schedule (Prateapusanond 2003, pp. 156)

The Start Finish database for the above case is as shown below:

Table 4-7: Start-Finish database

ID	As Planned			Day 40			Day 60			Day 110			As Built [day 130]		
	Start	Finish	TF	Start	Finish	TF	Start	Finish	TF	Start	Finish	TF	Start	Finish	TF
Activity A	0	130	0	0	130	0	0	130	0	0	130	0	0	130	
Sub. Shop Dwg	0	20	50	0	40		0	40		0	40		0	40	
Rev/App Shop Dwg	20	40	50	40	60	30	40	60		40	60		40	60	
Fab. Steel	40	60	50	60	80	30	60	80	30	60	110		60	110	
Erect Steel	60	80	50	80	100	30	80	100	30	110	130	0	110	130	

The corresponding ATF database is shown in Table 4-8.

Table 4-8: ATF database

ID	As Planned			Day 40			Day 60			Day 110			As Built [day 130]		
	TF	Owner	KR	TF	Owner	KR	TF	Owner	KR	TF	Owner	KR	TF	Owner	KR
Activity A	0	0	0	0	0	0	0	0	0	0	0	0	0	0	0
Sub. Shop Dwg	50	25	25	0	25	5	0	0	0	0	0	0	0	0	0
Rev/App Shop Dwg	50	25	25	30	25	5	0	25	5	0	0	0	0	0	0
Fab. Steel	50	25	25	30	25	5	30	25	5	0	25	-25	0	0	0
Erect Steel	50	25	25	30	25	5	30	25	5	0	25	-25	0	25	-25
						20 day Contractor delay			30 day Contractor delay						

At update 3, the contractor has used the entire 50 days of total float. The contractor owned just 25 days of float, whereas the owner owned the remaining 25 days. Hence, for activity “Erect Steel,” the float value shown under the KR column is -25. The owner does not cause any delay during the course of the project. This compensates for the additional days used by the contractor. Overall, there is no delay to the project and hence, the contractor is not penalized.

4.2.4 Owner delay < ATF, Contractor delay > ATF; Project Delay = 10 days

The As Built Schedule is as shown in Figure 4-7.

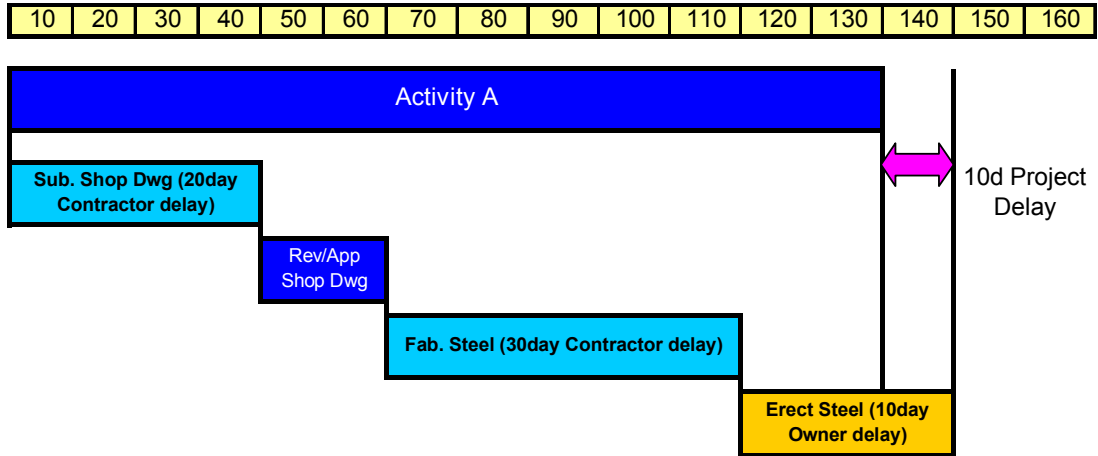

The contractor delays the submission of steel shop drawings for 20 days and delays the steel fabrication for 30 days; subsequently, the owner later delays the steel erection for 10 days. In sum, the contractor consumes steel activity float times for 50 days (25 days beyond the allowable amount) and the owner consumes float times for 10 days (within the allowable amount of 25 days). In this situation, the accumulation of all delays has affected the project completion date for 10 days. The owner who used float time within the allowable times does not have to respond for the project delay while the contractor is held responsible for the project delay of 10 days.

Figure 4-7. As Built Schedule (Prateapusanond 2003, pp. 159)

The Start Finish database for the above case is as shown in Table 4-9.

Table 4-9: Start-Finish database

ID	As Planned			Day 40			Day 60			Day 110			Day 130			As Built [day 140]		
	Start	Finish	TF	Start	Finish	TF	Start	Finish	TF	Start	Finish	TF	Start	Finish	TF	Start	Finish	TF
Activity A	0	130	0	0	130	0	0	130	0	0	130	0	0	130		0	130	
Sub. Shop Dwg	0	20	50	0	40		0	40		0	40		0	40		0	40	
Rev/App Shop Dwg	20	40	50	40	60	30	40	60		40	60		40	60		40	60	
Fab. Steel	40	60	50	60	80	30	60	80	30	60	110		60	110		60	110	
Erect Steel	60	80	50	80	100	30	80	100	30	110	130	0	110	130	0	110	140	-10

The corresponding ATF database is as shown in Table 4-10.

Table 4-10: ATF database

ID	As Planned			Day 40			Day 60			Day 110			Day 130			As Built [day 140]			
	TF	Owner	KR	TF	Owner	KR	TF	Owner	KR	TF	Owner	KR	TF	Owner	KR	TF	Owner	KR	
Activity A	0	0	0	0	0	0	0	0	0	0	0	0	0	0	0	0	0	0	
Sub. Shop Dwg	50	25	25	0	25	5	0	0	0	0	0	0	0	0	0	0	0	0	
Rev/App Shop Dwg	50	25	25	30	25	5	0	25	5	0	0	0	0	0	0	0	0	0	
Fab. Steel	50	25	25	30	25	5	30	25	5	0	25	-25	0	0	0	0	0	0	
Erect Steel	50	25	25	30	25	5	30	25	5	0	25	-25	0	25	-25	-10	15	-25	
				20 day Contractor delay							30 day Contractor delay								
														10 day Owner delay					

At update 3, the contractor delays the activity by 50 days of float, which is greater than the ATF value of 25 days. Until this point, though there is no delay to the project completion. The owner then delays Activity “Erect Steel” by 10 days which in turn, delays the completion of the project by 10 days. This activity is therefore the proximate cause of the delay and hence under the current scheduling practices, the owner is responsible for the delay.

According to the concept of “Pre-Allocation of Total Float,” the owner owns 25 days of float for that set of activities (since total float is shared by all the activities in that particular path) and uses 10 days from his allotted 25 days of total float. According to this new concept, it will be the contractor who has used 25 days more than his allotted ATF, and who will be penalized for the 10 days of delay.

4.2.5 Owner delay > ATF, Contractor delay > ATF; Project Delay = 30 days

In this example, we consider a combination of delays where both parties use more days than their allowable limit. The As Built Schedule is as shown in Figure 4-8.

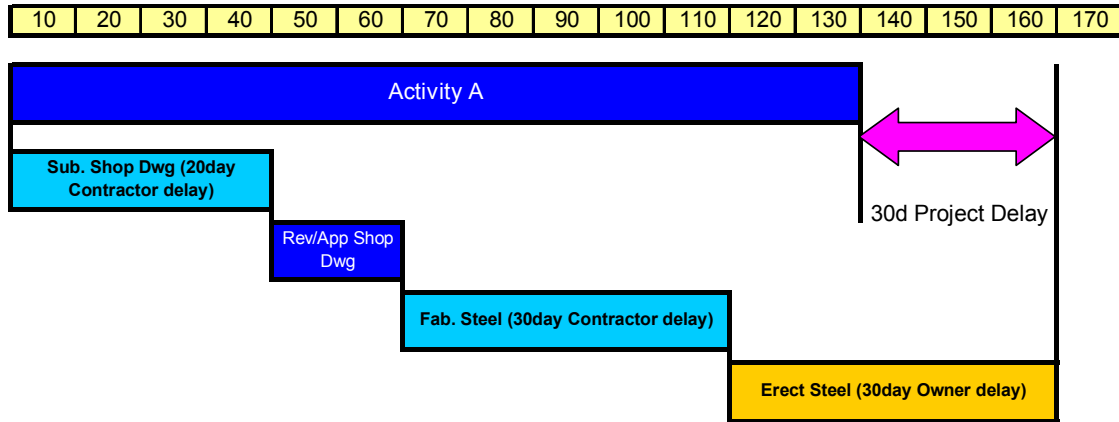

The contractor delays the submission of steel shop drawings for 20 days and delays the steel fabrication for 30 days; subsequently, the owner later delays the steel erection for 30 days. In sum, the contractor consumes float times of the steel activities for 50 days (25 days beyond the allowable amount) and the owner consumes float times for 30 days (5 days beyond the allowable amount). Under this situation, the accumulation of all delays has affected the project completion date for 30 days. The owner is held responsible for the project delay of 5 days while the contractor is held responsible for 25 days.

Figure 4-8. As Built Schedule (Prateapusanond 2003, pp. 162)

The Start-Finish database for the above case is as shown in Table 4-11.

Table 4-11: Start-Finish database

ID	As Planned			Day 40			Day 60			Day 110			Day 130			As Built [day 160]		
	Start	Finish	TF	Start	Finish	TF	Start	Finish	TF	Start	Finish	TF	Start	Finish	TF	Start	Finish	TF
Activity A	0	130	0	0	130	0	0	130	0	0	130	0	0	130		0	130	
Sub. Shop Dwg	0	20	50	0	40		0	40		0	40		0	40		0	40	
Rev/App Shop Dwg	20	40	50	40	60	30	40	60		40	60		40	60		40	60	
Fab. Steel	40	60	50	60	80	30	60	80	30	60	110		60	110		60	110	
Erect Steel	60	80	50	80	100	30	80	100	30	110	130	0	110	130	0	110	160	-30

The Concept of Pre-Allocation of Total Float: Bookkeeping Procedures

The corresponding ATF database is as shown in Table 4-12.

Table 4-12: ATF database

ID	As Planned			Day 40			Day 60			Day 110			Day 130			As Built [Day 160]		
	TF	Owner	KR	TF	Owner	KR	TF	Owner	KR	TF	Owner	KR	TF	Owner	KR	TF	Owner	KR
Activity A	0	0	0	0	0	0	0	0	0	0	0	0	0	0	0	0	0	0
Sub. Shop Dwg	50	25	25	0	25	5	0	0	0	0	0	0	0	0	0	0	0	0
Rev/App Shop Dwg	50	25	25	30	25	5	0	25	5	0	0	0	0	0	0	0	0	0
Fab. Steel	50	25	25	30	25	5	30	25	5	0	25	-25	0	0	0	0	0	0
Erect Steel	50	25	25	30	25	5	30	25	5	0	25	-25	0	25	-25	-30	-5	-25
				20 day Contractor delay						30 day Contractor delay						30 day Owner delay		

4.2.6 Considers 2 non-critical paths which eventually become critical

Legend:

	Activities awaiting completion, but on schedule
	As Built Owner delayed activities
	As Built Contractor delayed activities
	As Built activities completed on schedule
	Non-Critical non-started activities
	Critical Non-started activities
	Non-completed activities being delayed by owner
	Non-completed activities being delayed by contractor

The As-Planned Schedule is as shown in Figure 4-9.

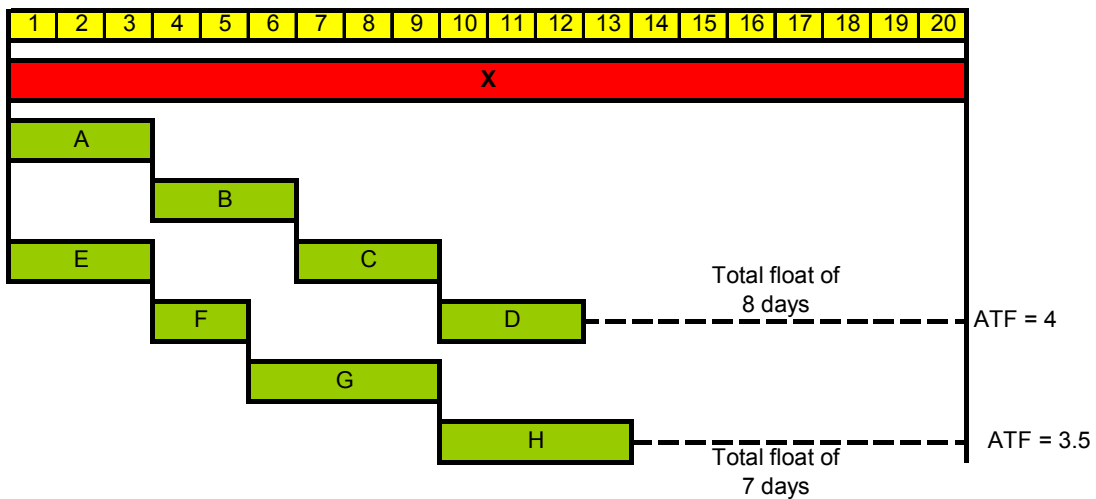
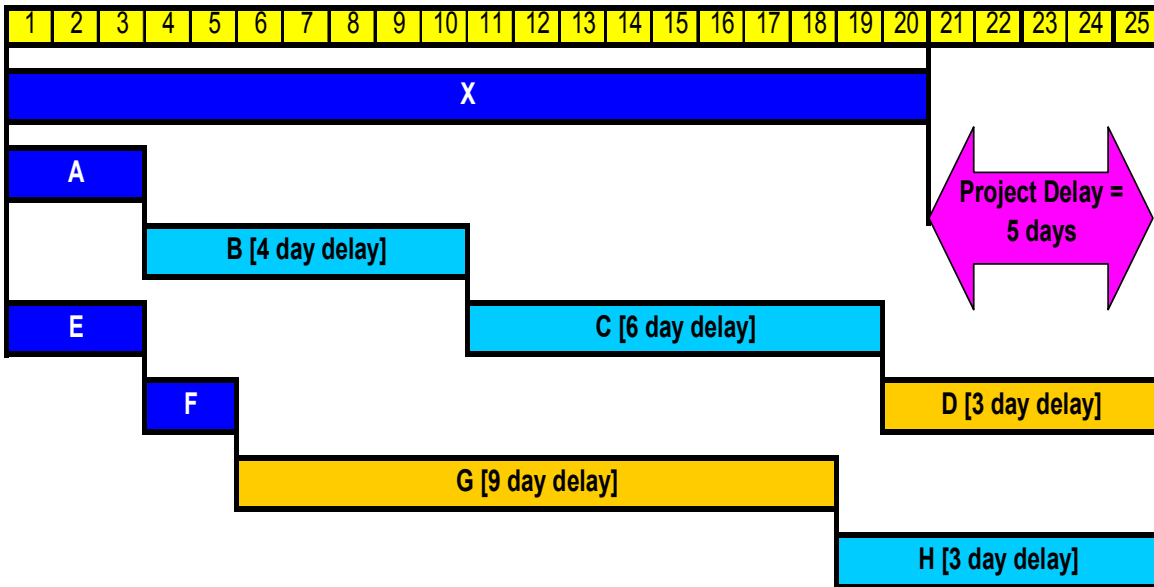

Figure 4-9. As-Planned Schedule (Prateapusanond 2003, pp. 164)

This example shows how the bookkeeping procedures can be used to keep track of concurrent delays. Activities A, B, C, D, and E have duration = 3 days. Activity F = 2 days and activities G and H have a 4 day duration each. Activity X represents the critical activity with duration of 20 days.

The As Built Schedule for the above example is as shown in Figure 4-10.



This case involves concurrent delays occurring on the two then-critical paths, an accumulation of which does change the project completion date for 5 days. Considering the first path of A – D, the contractor delays this path for 10 days in total which 6 days beyond its ATF while the owner delays this path for 3 days within its ATF. Therefore, the contractor is held responsible for 5 days of project delays on the activity path of A - D.

On the same token, the owner delays Activity G on the path of E – H for 9 days which 5.5 days beyond its ATF; and the contractor delays Activity H for 3 days within its ATF. On this path of E – H, the owner is held responsible for the 5-day project delay. In conclusion, since both parties are held responsible for the 5d project delay, the owner must give a 5d time extension to the contractor, but the 5 days of delay are not compensable.

Figure 4-10. As Built Schedule (Prateapusanond 2003, pp. 167)

The Start Finish database is as shown in Table 4-13.

Table 4-13: Start-Finish database

ID	As Planned			Day 3			Day 5			Day 10			Day 18			Day 19			Day 20			As Built [Day 25]				
	Start	Finish	TF	Start	Finish	TF	Start	Finish	TF	Start	Finish	TF	Start	Finish	TF	Start	Finish	TF	Start	Finish	TF	Start	Finish	TF		
X	0	20	0	0	20	0	0	20	0	0	20	0	0	20	2	0	20	2	0	20						
A	0	3	8	0	3		0	3		0	3		0	3		0	3		0	3		0	3			
B	3	6	8	3	6	8	3	6	8	3	10		3	10		3	10		3	10		3	10			
C	6	9	8	6	9	8	6	9	8	10	13	4	10	18	1	10	19		10	19		10	19			
D	9	12	8	9	12	8	9	12	8	13	16	4	19	21	1	19	22	0	19	22	0	19	25	-3		
E	0	3	7	0	3		0	3		0	3		0	3		0	3		0	3		0	3			
F	3	5	7	3	5	7	3	5	7	3	5		3	5		3	5		3	5		3	5			
G	5	9	7	5	9	7	5	9	7	5	10	6	5	18		5	18		5	18		5	18			
H	9	13	7	9	13	7	9	13	7	10	14	6	18	22	-2	18	22	-2	18	22	-2	18	25	-5		
												4d KR delay to activity B & 1d Owner delay to activity G			8d Owner delay to Activity G & 5d KR delay to activity C			1d KR delay to Activity C						3 day Owner and Contractor delay (Concurrent)		

The corresponding ATF database is as shown in Table 4-14.

Table 4-14: ATF database

ID	As Planned			Day 3			Day 5			Day 10			Day 18			Day 19			Day 20			As Built [Day25]				
	TF	Owner	KR	TF	Owner	KR	TF	Owner	KR	TF	Owner	KR	TF	Owner	KR	TF	Owner	KR	TF	Owner	KR	TF	Owner	KR		
X	0	0	0	0	0	0	0	0	0	0	0	0	2	1	1	2	1	1	0	1	1	0	0	0		
A	8	4	4	0	4	4	0	0	0	0	0	0	0	0	0	0	0	0	0	0	0	0	0	0		
B	8	4	4	8	4	4	8	4	4	0	4	0	0	0	0	0	0	0	0	0	0	0	0	0		
C	8	4	4	8	4	4	8	4	4	4	4	0	1	5	-4	0	5	-5	0	0	0	0	0	0		
D	8	4	4	8	4	4	8	4	4	4	4	0	1	5	-4	0	5	-5	0	5	-5	-3	2	-5		
E	7	3.5	3.5	0	3.5	3.5	0	0	0	0	0	0	0	0	0	0	0	0	0	0	0	0	0	0		
F	7	3.5	3.5	7	3.5	3.5	0	3.5	3.5	0	0	0	0	0	0	0	0	0	0	0	0	0	0	0		
G	7	3.5	3.5	7	3.5	3.5	7	3.5	3.5	6	2.5	3.5	0	-5.5	3.5	0	0	0	0	0	0	0	0	0		
H	7	3.5	3.5	7	3.5	3.5	7	3.5	3.5	6	2.5	3.5	-2	-5.5	3.5	-2	-5.5	3.5	-2	-5.5	3.5	-5	-5.5	0.5		
												4d KR delay to activity B & 1d Owner delay to activity G			8d Owner delay to Activity G & 5d KR delay to activity C			1d KR delay to Activity C						3 day Owner and Contractor delay (Concurrent)		

The Analysis:

The project status as of day 5 is as shown in Figure 4-11.

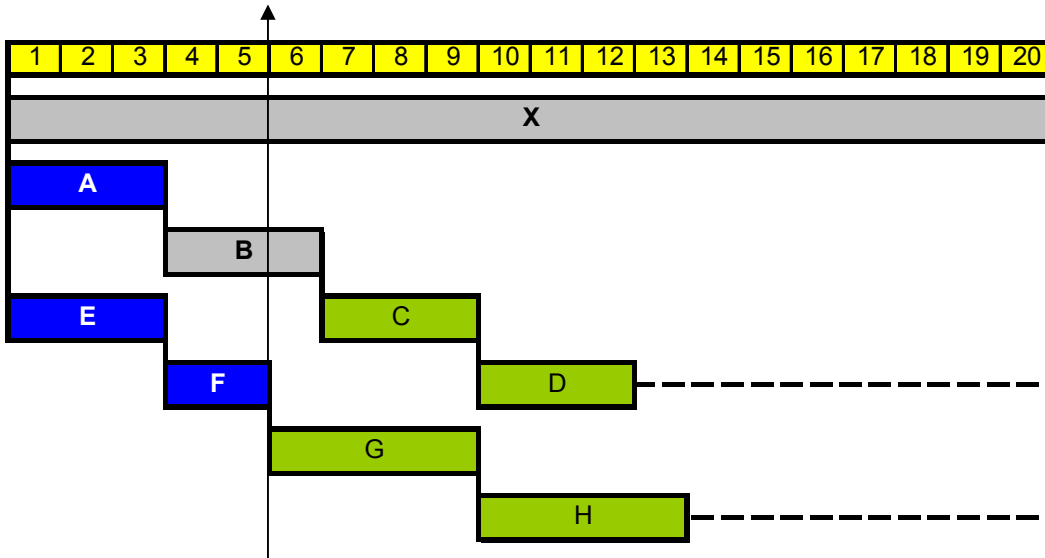

Figure 4-11. Project Status as of Day 5

As illustrated in Figure 4-11, activities A, E, and F are completed on schedule. Activity B has an actual start, but is not yet completed and hence is shown in **Grey**. The next update is carried out on day 10. The project status as of day 10 is as shown in Figure 4-12.

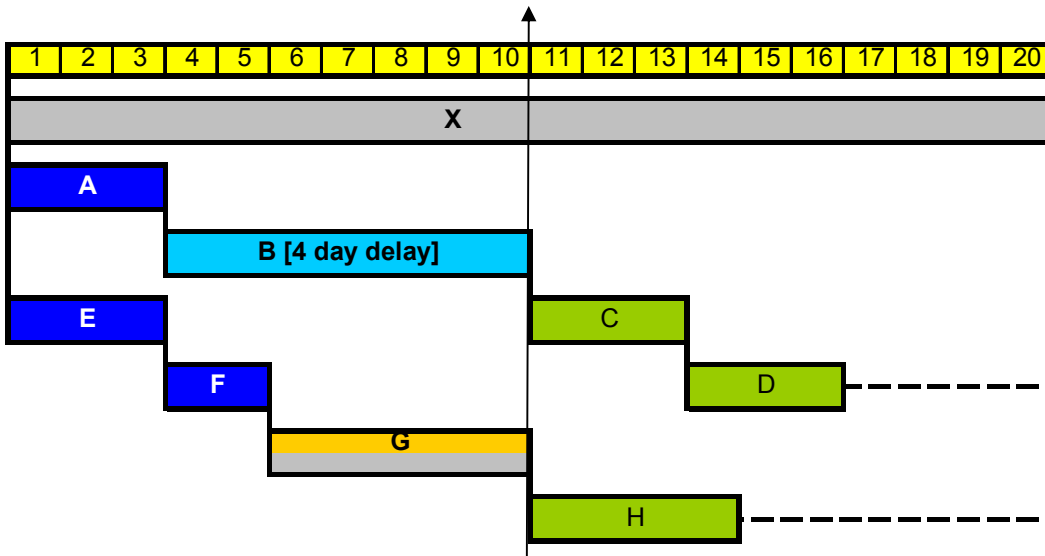

Figure 4-12. Project Status as of Day 10

As shown in Figure 4-12, the completion of activity B is delayed by 4 days. This decreases the total float on activities C and D by 4 days. The contractor is held responsible for this delay and the corresponding decrease in float. The owner will still own his 4 days ATF for this path [as shown in Table 4-12]

As of day 10, activity G has not yet been completed and its completion time is uncertain. Activity G is suffering from an owner responsible delay. As of day 10, this activity records a delay of 1 day, which shifts activity H by 1 day. It also reduces the float for activities G and H by 1 day for which the owner is held responsible, and the corresponding value is deducted from the owner's ATF [as shown in table 4-12].

This delay does not affect the project completion but the noticeable effects can be summarized as:

- Reduction in float for activities C and D; contractor held responsible
- Activity G still not completed
 - reduction in float for activities G and H; owner held responsible
 - Start of activity H delayed

The next update is carried out on day 18. The project status as of day 18 is as shown in Figure 4-13.

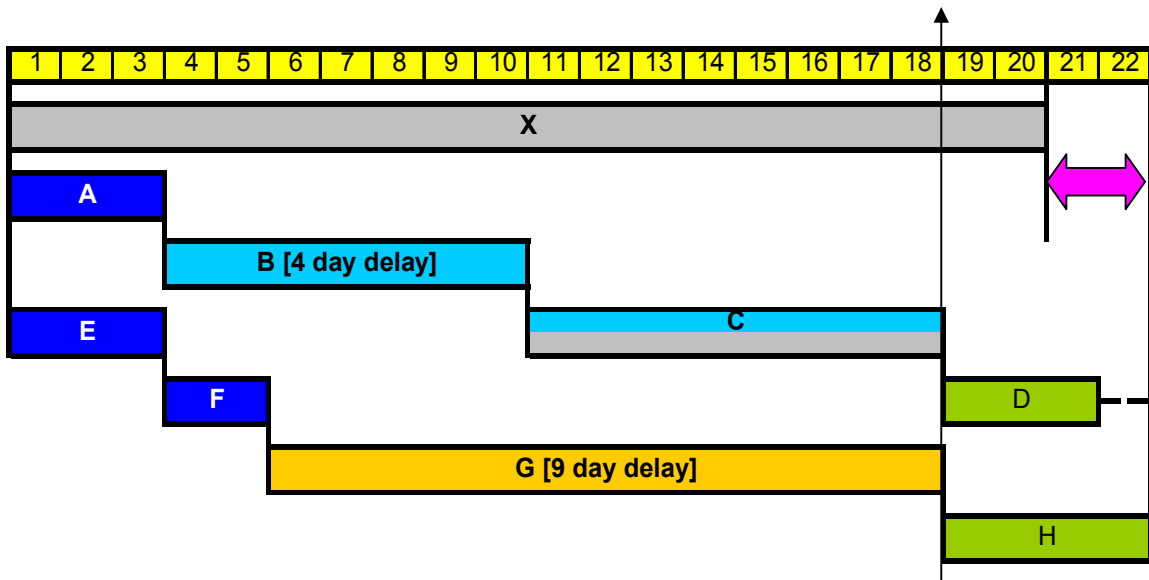

Figure 4-13. Project Status as of Day 18

As illustrated in Figure 4-13, the completion of activity G is delayed by 9 days. Until the last update, activities G and H had a float of 6 days out of which the owner owned 2.5 days [$3.5(\text{initial float}) - 1(\text{delay to activity G as of Day 10}) = 2.5 \text{ days}$]. An additional delay of 8 days to activity G delays the project by 2 days, because of which activity H now becomes critical. The owner is held responsible for this delay and its corresponding effect to the ATF values is seen in Table 4-14. The project delay of two days is represented by “-2” TF in Table 4-14.

The project delay of 2 days consequentially increases the float for activities C and D by 2 days. This newly created float is split equally between the parties and hence activities C and D now have a float of 6 days out which 5 days are owned by the owner and 1 day by the contractor.

The delay of 2 days to the project completion makes activity X non-critical. It now has newly created float of two days that is also split equally between the two parties.

As of day 18, activity C has not yet been completed. The contractor has delayed activity C and the activity completion time is uncertain. Hence, for this update, activity C is stretched to day 18, which delays the start of activity D. After the newly created float, the path had a total float of 6 days. Activity C has already used up 5 days of this float and now the activities C and D share a float of 1 day amongst themselves. The contractor is held responsible for this delay and hence this value of 5 days is subtracted from the contractor’s ATF value [as shown in Table 4-14].

The noticeable effects of the delay could be summarized as:

- Delay to project completion by 2 days
- Activity H is now critical
- Newly created float for activities C and D
- Activity C is stretched to day 18 since it has not yet been completed. Hence, the contractor has already delayed this activity by 5 days. The corresponding effect to float values is seen in Table 3-14.
- Activity X has newly created float of 2 days that is split equally between the parties.

The next update is carried out on day 19. Activity C has been delayed further by 1 day. This makes activity D critical. The project status as of day 19 is as shown in Figure 4-14.

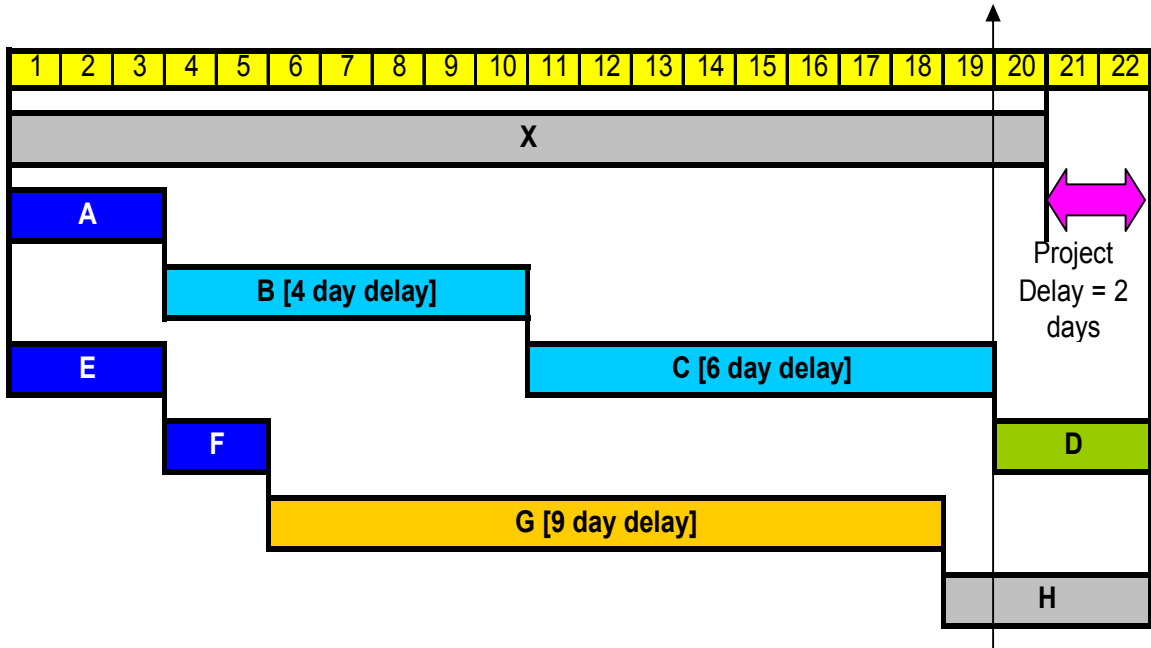

Figure 4-14. Project Status as of Day 19

As illustrated in Figure 4-14, activity D had a float of 1 day remaining at the end of the last update. This delay to activity C makes activity D critical. The contractor is held responsible for this delay.

Activity X is completed as per schedule. The final update is carried out on day 25. It is realized that the owner has delayed the completion of activity D by 3 days concurrently with the contractor's delay of 3 days to activity H. The As-Built Schedule is as shown in Figure 4-15.

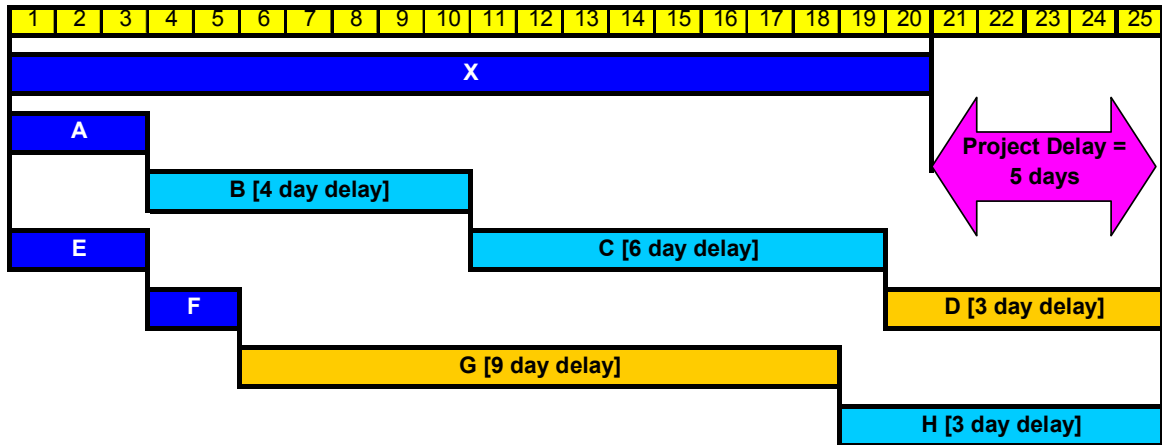

Figure 4-15. As Built Schedule (Prateapusanond 2003, pp. 167)

In this example, both the non-critical paths, i.e., A-B-C-D and E-F-G-H, become critical. The owner would be responsible for all 5 days of delay because path E-F-G-H produces the longest path and the longest delay, i.e., $-5.5 + 0.5 = -5$ [refer to Table 3-14]. The path A-B-C-D produces a 3-day delay i.e. $+2 - 5 = -3$ [refer to Table 3-14].

4.2.7 Example showing multiple non-critical paths

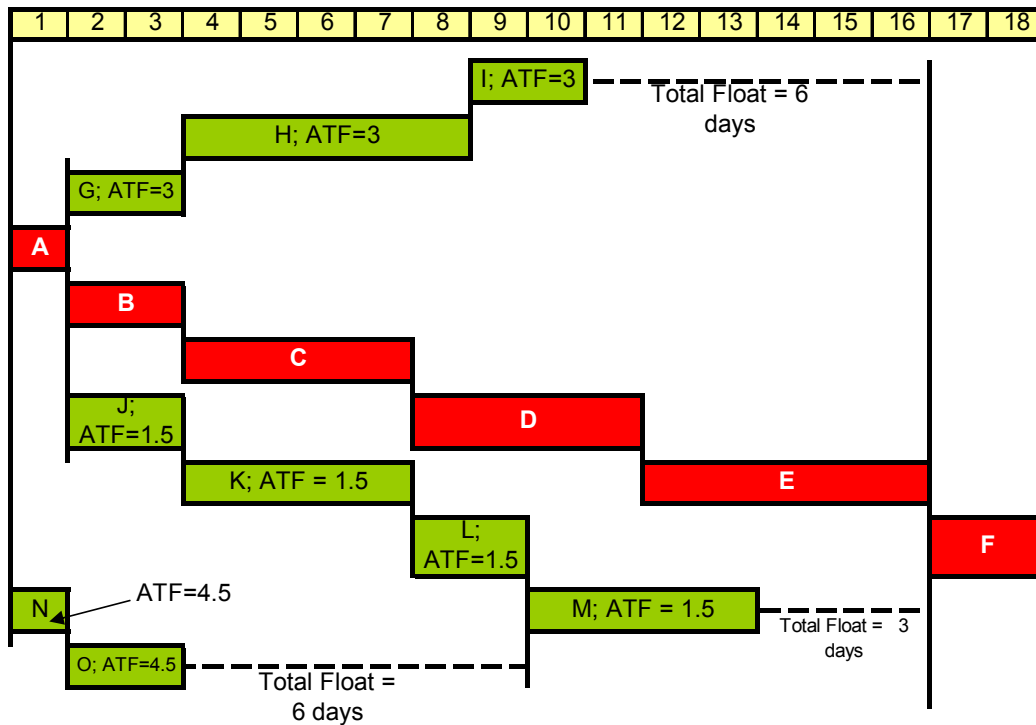

Figure 4-16. As-Planned Schedule (Prateapusanond 2003, pp. 169)

The durations of activities are:

- 1 day => Activity A and N
- 2 days => Activities B, F, G, I, J, L, and O
- 4 days => Activities C, D, K, and M
- 5 days => Activities E and H

The As Built Schedule is as shown in Figure 4-17.

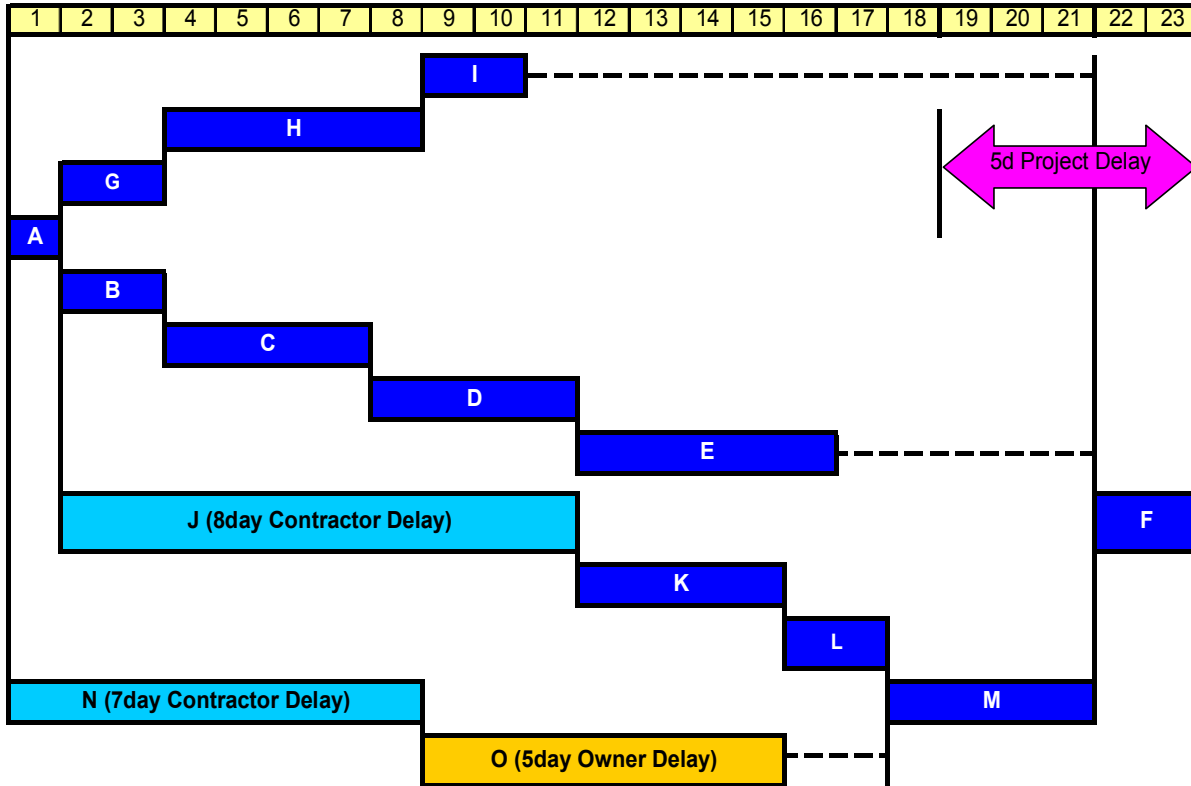

Figure 4-17. As Built Schedule (Prateapusanond 2003, pp. 171)

The contractor delays activity J and N by 8 days and 7 days, respectively. The owner delays activity O by 5 days. The net effect of these delays is a delay of 5 days to the project completion.

The corresponding Start Finish database is as shown in Table 4-15.

Table 4-15: Start-Finish database

ID	As Planned			Day 1			Day 3			Day 7			Day 8			Day 10			Day 11			Day 15			Day 16			Day 17			Day 21			As Built [day23]				
	Start	Finish	TF	Start	Finish	TF	Start	Finish	TF	Start	Finish	TF	Start	Finish	TF	Start	Finish	TF	Start	Finish	TF	Start	Finish	TF	Start	Finish	TF	Start	Finish	TF	Start	Finish	TF	Start	Finish	TF	Start	Finish
A	0	1	0	0	1		0	1		0	1		0	1		0	1		0	1		0	1		0	1		0	1		0	1		0	1			
B	1	3	0	1	3	0	1	3		1	3		1	3		1	3		1	3		1	3		1	3		1	3		1	3		1	3			
C	3	7	0	3	7	0	3	7	0	3	7		3	7		3	7		3	7		3	7		3	7		3	7		3	7		3	7			
D	7	11	0	7	11	0	7	11	0	7	11	1	7	11	2	7	11	4	7	11		7	11		7	11		7	11		7	11		7	11			
E	11	16	0	11	16	0	11	16	0	11	16	1	11	16	2	11	16	4	11	16	5	11	16	5	11	16		11	16		11	16		11	16			
F	16	18	0	16	18	0	16	18	0	17	19	-1	18	20	-2	20	22	-4	21	23	-5	21	23	-5	21	23	-5	21	23	-5	21	23	-5	21	23			
G	1	3	6	1	3	6	1	3		1	3		1	3		1	3		1	3		1	3		1	3		1	3		1	3		1	3			
H	3	8	6	3	8	6	3	8	6	3	8	7	3	8		3	8		3	8		3	8		3	8		3	8		3	8		3	8			
I	8	10	6	8	10	6	8	10	6	8	10	7	8	10	8	8	10		8	10		8	10		8	10		8	10		8	10		8	10			
J	1	3	3	1	3	3	1	3	3	1	7	-1	1	8	-2	1	10	-4	1	11		1	11		1	11		1	11		1	11		1	11			
K	3	7	3	3	7	3	3	7	3	7	11	-1	8	12	-2	10	14	-4	11	15	-5	11	15		11	15		11	15		11	15		11	15			
L	7	9	3	7	9	3	7	9	3	11	13	-1	12	14	-2	14	16	-4	15	17	-5	15	17	-5	15	17	-5	15	17		15	17		15	17			
M	9	13	3	9	13	3	9	13	3	13	17	-1	14	18	-2	16	20	-4	17	21	-5	17	21	-5	17	21	-5	17	21	-5	17	21		17	21			
N	0	1	9	0	1	9	0	3	7	0	7	4	0	8		0	8		0	8		0	8		0	8		0	8		0	8		0	8			
O	1	3	9	1	3	9	3	5	7	7	9	4	8	10	4	8	10	6	8	11	6	8	15		8	15		8	15		8	15		8	15			
							2d KR delay to Act. N			4d KR delays to Act. J & N			1d KR delay to Act. J & N			2d KR delay to Act. J			1d KR delay to Act. J; 1d Owner delay to Act. O			4d Owner delay to Act. O																

The Corresponding ATF database is as shown in Table 4-16.

Table 4-16: ATF database

ID	As Planned			Day 1			Day 3			Day 7			Day 8			Day 10			Day 11			Day 15			Day 16			Day 17			Day 21			As Built [day23]				
	TF	Owner	KR	TF	Owner	KR	TF	Owner	KR	TF	Owner	KR	TF	Owner	KR	TF	Owner	KR	TF	Owner	KR	TF	Owner	KR	TF	Owner	KR	TF	Owner	KR	TF	Owner	KR	TF	Owner	KR	TF	Owner
A	0	0	0	0	0	0	0	0	0	0	0	0	0	0	0	0	0	0	0	0	0	0	0	0	0	0	0	0	0	0	0	0	0	0	0	0		
B	0	0	0	0	0	0	0	0	0	0	0	0	0	0	0	0	0	0	0	0	0	0	0	0	0	0	0	0	0	0	0	0	0	0	0	0		
C	0	0	0	0	0	0	0	0	0	0	0	0	0	0	0	0	0	0	0	0	0	0	0	0	0	0	0	0	0	0	0	0	0	0	0	0		
D	0	0	0	0	0	0	0	0	0	1	0.5	0.5	2	1	1	4	2	2	0	2	2	0	0	0	0	0	0	0	0	0	0	0	0	0	0	0	0	
E	0	0	0	0	0	0	0	0	0	1	0.5	0.5	2	1	1	4	2	2	5	2.5	2.5	5	2.5	2.5	0	2.5	2.5	0	0	0	0	0	0	0	0	0		
F	0	0	0	0	0	0	0	0	0	-1	0	-1	-2	0	-2	-4	0	-4	-5	0	-5	-5	0	-5	-5	0	-5	-5	0	-5	-5	0	-5	-5	0	-5		
G	6	3	3	6	3	3	0	0	0	0	0	0	0	0	0	0	0	0	0	0	0	0	0	0	0	0	0	0	0	0	0	0	0	0	0	0		
H	6	3	3	6	3	3	6	3	3	7	3.5	3.5	0	3.5	3.5	0	0	0	0	0	0	0	0	0	0	0	0	0	0	0	0	0	0	0	0	0		
I	6	3	3	6	3	3	6	3	3	7	3.5	3.5	8	4	4	0	4	4	0	0	0	0	0	0	0	0	0	0	0	0	0	0	0	0	0	0		
J	3	1.5	1.5	3	1.5	1.5	3	1.5	1.5	-1	1.5	-2.5	-2	1.5	-3.5	-4	1.5	-5.5	0	1.5	-6.5	0	0	0	0	0	0	0	0	0	0	0	0	0	0	0		
K	3	1.5	1.5	3	1.5	1.5	3	1.5	1.5	-1	1.5	-2.5	-2	1.5	-3.5	-4	1.5	-5.5	-5	1.5	-6.5	0	1.5	-6.5	0	0	0	0	0	0	0	0	0	0	0	0		
L	3	1.5	1.5	3	1.5	1.5	3	1.5	1.5	-1	1.5	-2.5	-2	1.5	-3.5	-4	1.5	-5.5	-5	1.5	-6.5	-5	1.5	-6.5	-5	1.5	-6.5	0	1.5	-6.5	0	0	0	0	0	0		
M	3	1.5	1.5	3	1.5	1.5	3	1.5	1.5	-1	1.5	-2.5	-2	1.5	-3.5	-4	1.5	-5.5	-5	1.5	-6.5	-5	1.5	-6.5	-5	1.5	-6.5	-5	1.5	-6.5	-5	1.5	-6.5	0	0	0		
N	9	4.5	4.5	9	4.5	4.5	7	4.5	2.5	4	4.5	-0.5	0	4.5	-0.5	0	0	0	0	0	0	0	0	0	0	0	0	0	0	0	0	0	0	0	0	0		
O	9	4.5	4.5	9	4.5	4.5	7	4.5	2.5	4	4.5	-0.5	4	4.5	-0.5	6	5.5	0.5	6	5	1	0	1.5	0.5	0	0	0	0	0	0	0	0	0	0	0	0		
							2d KR delay to Act. N			4d KR delays to Act. J & N			1d KR delay to Act. J & N			2d KR delay to Act. J			1d KR delay to Act. J; 1d Owner delay to Act. O			4d Owner delay to Act. O																

The Analysis:

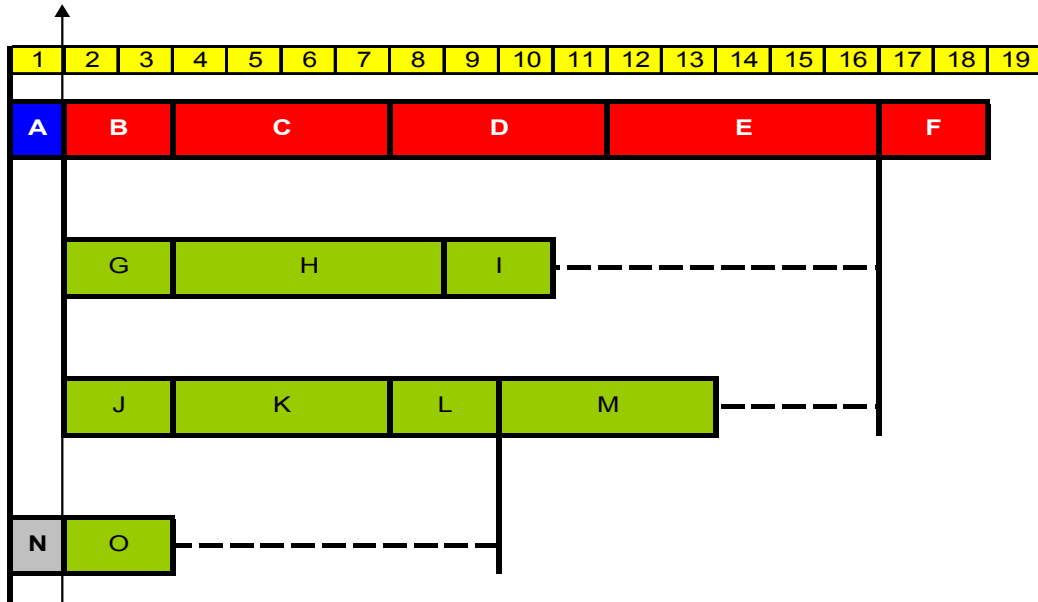

Figure 4-18. Project Status as of Day 1

The first update is carried out at day 1. Activity A is completed on schedule. Activity N has an actually start but its completion is uncertain. The project status as of day 1 is as shown in Figure 4-18.

The next update is carried out on day 3. The project status as of day 3 is as shown in figure 4-19.

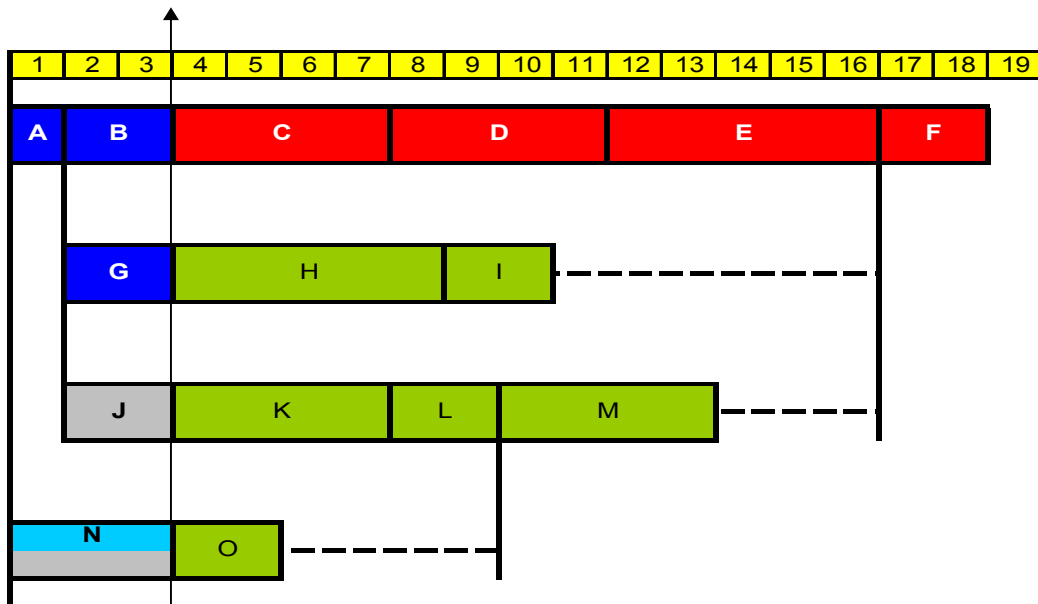

Figure 4-19. Project Status as of Day 3

As of day 3,

- Activity B is completed as per schedule
- The completion of activity N is still uncertain

Hence, for this update activity N is stretched to 3 days. This delays the start of activity O and reduces the float for activities N and O by 2 days. The contractor is delaying the completion of activity N and hence, the contractor is penalized for this reduction in float value. Thus, the value of TF for activities N and O reduce from 9 days to 7 days and the ATF value for the contractor for these activities reduces from 4.5 to 2.5, respectively (as shown in Table 3-16).

The next update is carried out on Day 7. The project status as of day 7 is as shown in the Figure 4-20.

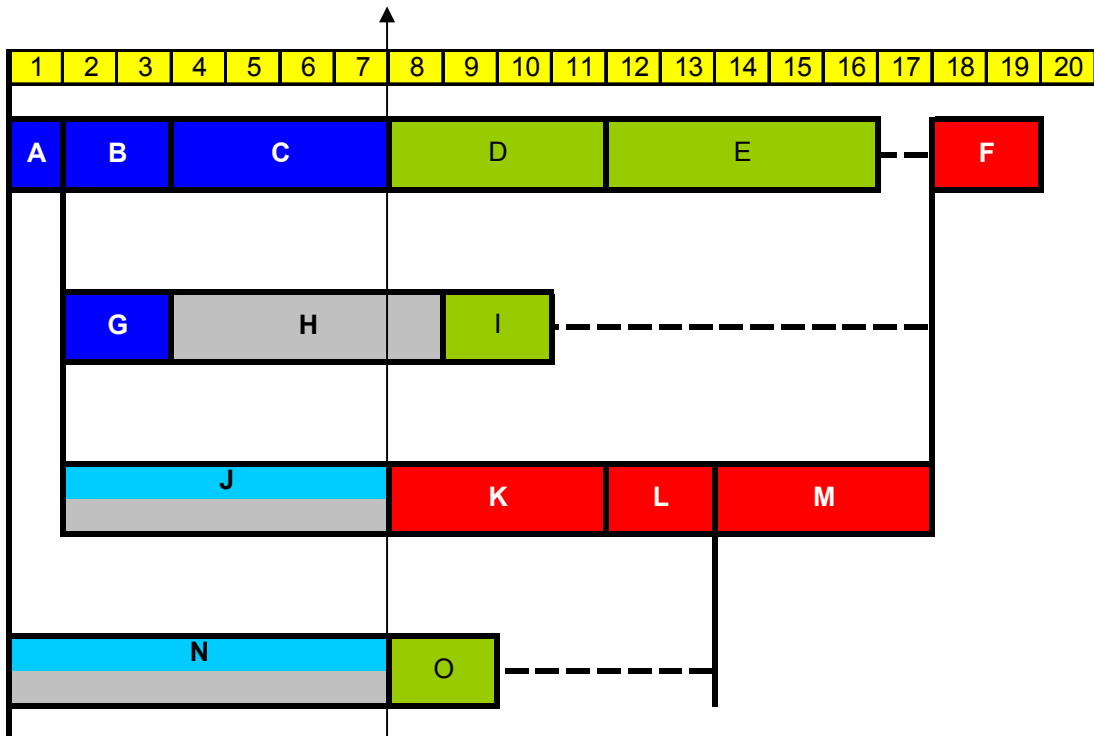

Figure 4-20. Project Status as of Day 7

As of Day 7,

- Activity C is completed as per schedule
- The completion of activities J and H is still uncertain
- Activity H has an actual start date and is progressing as per schedule

Hence, for this update, activities J and H are stretched to day 7. This delays the start of activities K and O respectively.

The contractor continues to delay the completion of activity N whereas the contractor also delays the completion of Activity J concurrently.

Path J-K-L-M

Activities J, K, L, and M shared a float of 3 days. This 4-day delay makes these activities critical. In fact, there is now a delay of 1 day to the project completion. This has three significant impacts:

- Activities D and E are no longer critical, and share a newly created float of 1 day
- Activities N and O lose the 3 days of float, which was shared with activity M since activity M is now critical.
- The total float for activities H and I also increases by 1 day due to this delay.

Path N-O

Activity N also experiences a delay of 4 days but this delay is concurrent with the delay to Activity J. Hence, this delay has no impact on the total float values for the activities in this path.

The next update is carried out on Day 8. The project status as of day 8 is as shown in figure 4-21.

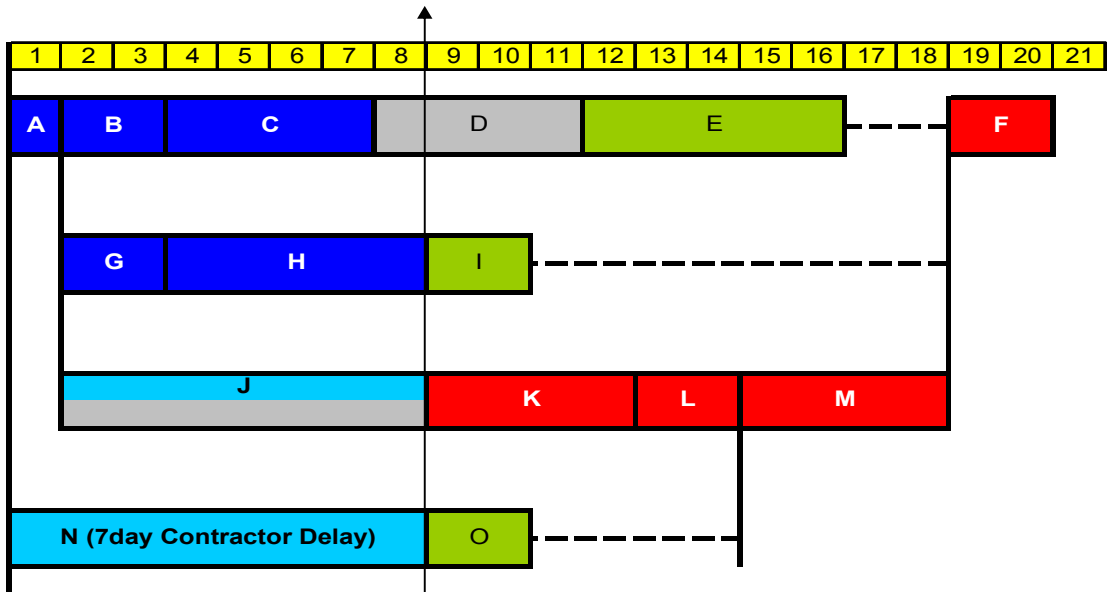

Figure 4-21. Project Status as of Day 8

As of Day 8, as illustrated in figure 4-21,

- Activity H is completed as per schedule
- Activity D has an actual start and progresses as per schedule
- Activity N is further delayed by one more day for its completion
- The completion of activity J is still uncertain and hence it records one more day of delay until the update that further delays the project by a day

The delays to activity J and N are concurrent and hence the delay to activity N does affect the project completion or the total float values for the activities in that path. Nevertheless, the delay to activity J delays the project completion by one more day and it increases the float for activities E and I by 1 day. This newly created float is split equally between the participating parties (as shown in Table 4-16).

The next update is carried out on day 10. The project status as of day 10 is as shown in figure 4-22.

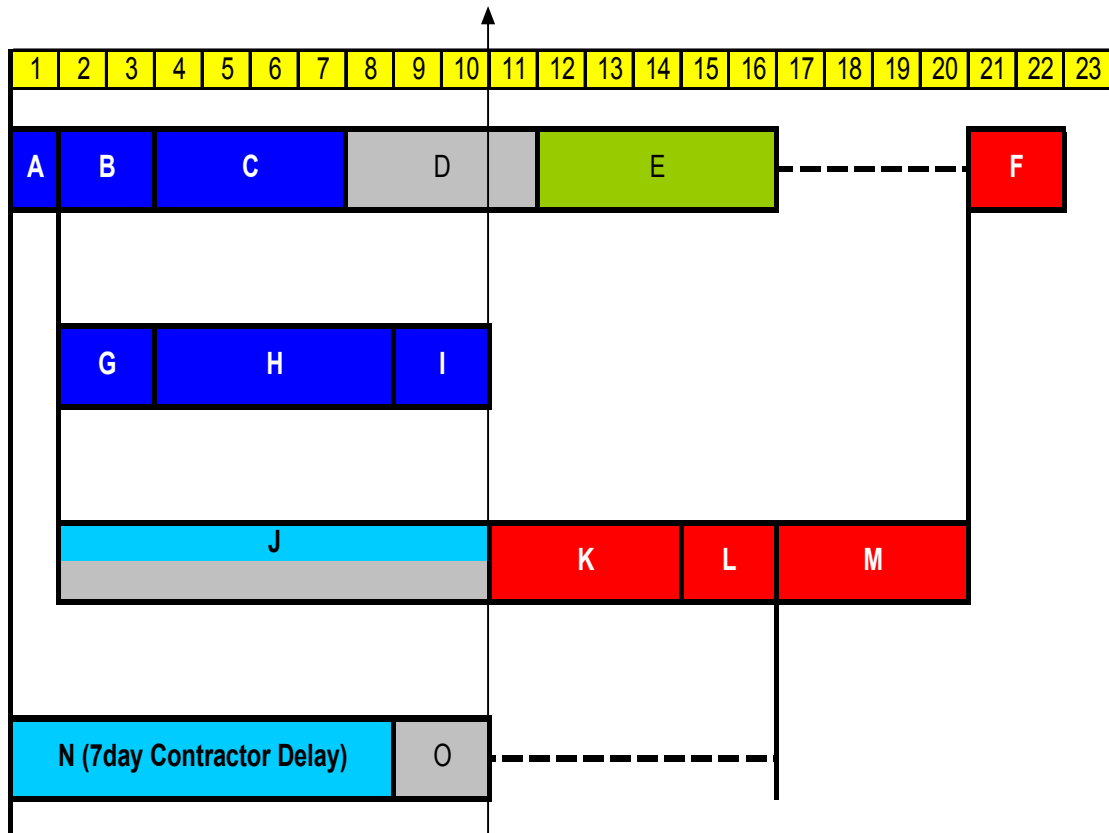

Figure 4-22. Project Status as of Day 10

As illustrated in Figure 4-22,

- Activity I is completed as per schedule
- Activity D that is progressing is on schedule as well
- Activity O has an actual start but its completion is uncertain
- The completion of activity J is still uncertain.

Hence, for this update, Activity J is stretched to day 10. This further delays the project by 2 days and as a result increases the float for activity E by 2 days. The participating parties share this newly created float. (As shown in Table 4-16)

The next update is carried out on day 11. The project status as of day 11 is as shown in the figure 4-23.

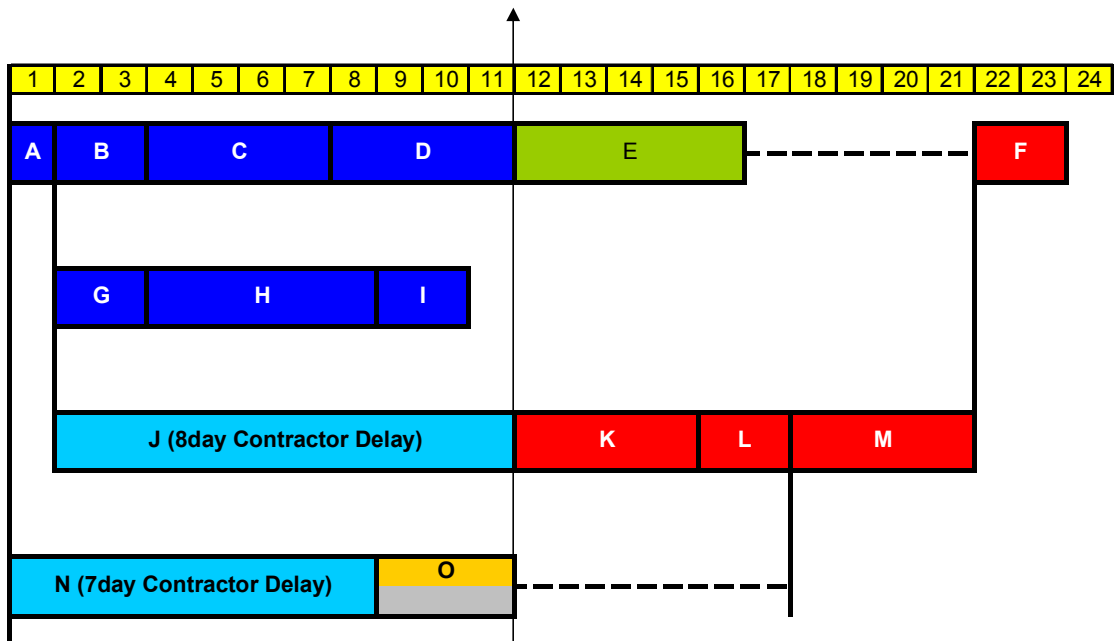

Figure 4-23. Project Status as of Day 11

As of Day 11,

- Activity D is completed on schedule
- Activity J is further delayed by 1 day and has now been completed. This delays the project by one more day and as a result increases the float on Activity E by one day.
- The completion of activity O is still uncertain

Hence, for this update, activity O is stretched to Day 11. The delay to Activity J increases the float for Activity O by 1 day. This one day of float is split equally between the owner and the contractor and hence the respective ATF values are 6 (5.5 + 0.5) and 1 (0.5 + 0.5). The delay to activity O is an owner responsible delay and hence the reduction in total float for activity O due to this delay is the owner's responsibility. Hence the final values of ATF for activity O are:

$$\text{Owner} = 6 - 1 = 5 \text{ days}$$

$$\text{Contractor} = 1 \text{ day} \quad (\text{as shown in Table 4-16})$$

The next update is carried out on Day 15. The project status as of day 15 is as shown in the Figure 4-24.

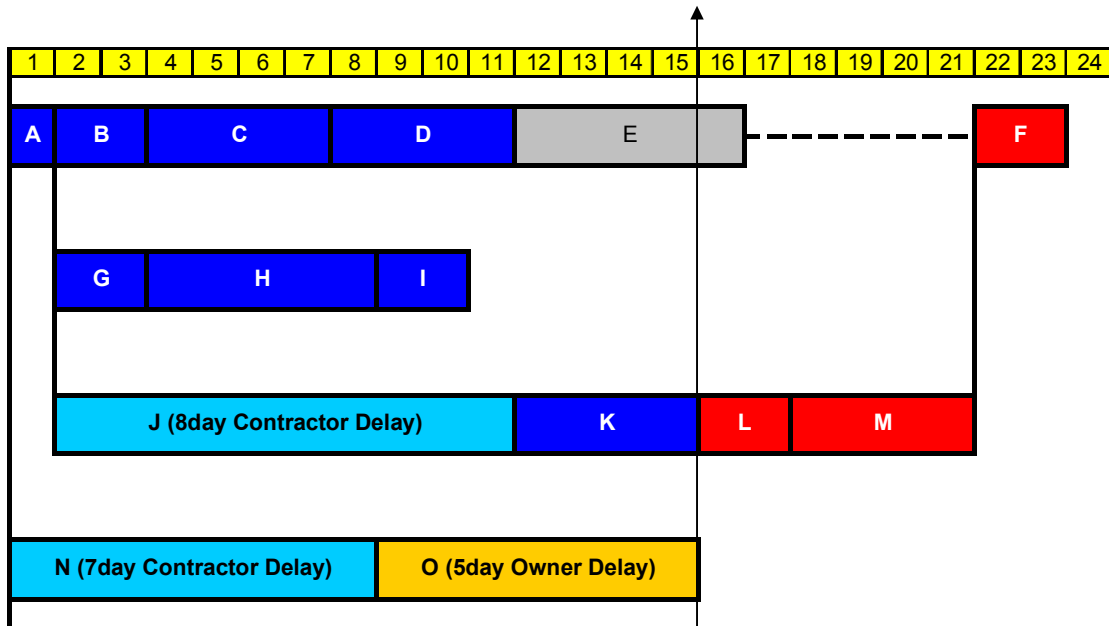

Figure 4-24. Project Status as of Day 15

As illustrated in Figure 4-24,

- Activity E is progressing as per schedule
- Activity K is completed on schedule
- Activity O is further delayed by 4 days for its completion

Activity O had a float of 6 days and hence this 4-day delay does not have any effect on the project completion. The delay is an owner responsible delay and hence the corresponding value is deducted from the owners ATF for activity O (as shown in Table 3-16).

The rest of the activities are completed as per schedule. Hence, in this example, the contractor is held responsible for the project delay.

Chapter 5

Applying the concepts to a real construction project

The bookkeeping procedures developed were successfully applied to the factual examples developed by Prateapusanond (2003) in Chapter 4. Even though the examples cover a number of different scenarios, the validity of the developed concepts could still be questioned with respect to its application on complex construction projects. To make sure that the concept and the bookkeeping procedures can be successfully applied to any project, it was decided to apply these concepts on a real construction project schedule. The project chosen for this purpose was the Alumni Continuing Education Center Hotel Complex (ACECHC) at Virginia Polytechnic Institute and State University (Virginia Tech), Blacksburg, Virginia.

5.1 Alumni Continuing Education Center Hotel Complex: Brief Overview

The construction of the ACECHC is currently being undertaken near the Duck Pond on the Virginia Tech golf course. This new project includes a state of the art conference center and hotel, as well as a museum dedicated to the Virginia Tech memorabilia.

Project Motive and Project Specifics

Virginia Tech is a senior land grant institution whose aim is to be amongst the top 30 research institutions by 2010. The ACECHC project was planned keeping in mind this motive and with the idea of replacing Donaldson Brown as the continuing education center.

The Concept of Pre-Allocation of Total Float: Bookkeeping Procedures

The main criteria during the project planning phase was for this facility to be close to the main campus, have scope for future expansion and most importantly, easy to locate on campus. A highly landscaped facility was another major requirement for this project. Keeping all these requirements in mind, the Virginia Tech Golf Course was chosen as the most appropriate location on campus for the ACECHC project. The contract amount for the project is \$31,490,700.00 with the entire facility expected to be costing around \$45,000,000.00. This requires an overall construction of approximately 184,000 sq. ft. on an area of 23 acres.

The parties involved are:

<i>Owner:</i>	Virginia Polytechnic Institute & State University
<i>Architect:</i>	Sherertz Franklin Crawford Shaffner, Inc.
<i>General Contractor:</i>	Branch & Associates, Inc.
<i>Project Start Date:</i>	April 14, 2003 (Notice to Proceed)
<i>Initial Project Completion Date:</i>	March 21, 2005

The entire project is divided into three parts:

The Alumni Hall:

Housing the museum dedicated to the Virginia Tech memorabilia, the Alumni Hall will be a three-level, 50,000 sq. ft. structure, which uses Hokie Stones mounted over concrete masonry units. The facility is designed with high-end castellan architecture with a collegiate gothic aesthetic.

The Continuing Education and Conference Center:

This is a three-level, 70,000 sq. ft. facility, expected to house the banquet room, meeting rooms and other administrative offices.

The Hotel Complex:

A four-level, 64,000 sq. ft. hotel complex housing 143 single guest rooms and 6 suites. Virginia Tech has issued revenue bonds worth \$20,000,000 to Hilton as the operating body.

Contractor Information

The general contractor chosen for this job is Branch & Associates, Inc. They have been general contractors since 41 years and are licensed to work in the states of North Carolina, Tennessee, Virginia, and West Virginia. Branch & Associates is a 100% employee owned company with a bonding capacity of around \$300,000,000 and has already done work worth \$275,000,000 in college and university construction. Being in this business for over 40 years now, Branch & Associates has successfully completed a total of 15 projects at Virginia Tech since 1989.

Project Schedule

Branch & Associates, Inc. developed a project schedule for this project. The contract had a notice to proceed of April 14, 2003, and the project was expected to finish by spring 2005. This As Planned Schedule had 993 activities with a completion date of March 21, 2005. During the course of the project, in the summer of 2003, the area experienced heavy rains because of which there was a delay to the project completion of 45 days. The project had also suffered an additional delay of 14 days due to change orders. After negotiations between the parties, the newly adjusted contract completion date for the project was set for May 19, 2005. There is no clause in the contract for liquidated damages, but the contract clearly specifies that the contractor would be held responsible for damages in case of any delay to the start of this facility.

Contract Enforcement

The contract on this project is enforced jointly by the Architects/Engineers (A/E) and the General Contractor (GC). The owner has also hired McDonough Bolyard Peck (MBP) as the construction manager, which approves the progress payments, change orders and the project schedule. The A/E and the GC meet the requirements of their respective contracts and advise the owner of the status of the project and MBP keeps a constant supervision.

5.2 The As-Planned Schedule

Branch & Associates has been generous in providing schedule updates every month to facilitate this research. The first schedule received from Branch & Associates was the June update, also the first resource loaded schedule for the project. This research is aimed at applying the concept of Pre-Allocation of Total Float to the ongoing ACECHC project schedule and then carrying out an impact analysis on the schedule updates. To achieve this purpose there was a need for an As-Planned Schedule. No As-Planned Schedule was provided during the course of this research. The June schedule provided was an updated schedule and hence, to go on with this research, there was a need to develop an As Planned Schedule.

To develop this As-Planned Schedule, the constraint type for all the activities in the June schedule was changed to “as soon as possible” and the corresponding updates of all the updated activities were removed, i.e., percentage complete for all activities was changed to 0%. This procedure did not provide the same result as an actual As-Planned schedule would have, so to carry on with this research, the following assumption was made. According to this newly developed As-Planned Schedule, the notice to proceed is April 15, 2003, and the project completion date is May 19, 2005

The Start-Finish database for the As-Planned Schedule was made using this schedule. The same schedule was then analyzed to find the respective total float values for each activity and to calculate the allowable total float owned by the parties for each corresponding activity and thereby create the ATF database. Appendix A shows the combined Start-Finish and the Allowable Total Float (ATF) database for the developed As-Planned Schedule. The activities highlighted in yellow are the hammocks that give us an overall picture of how long that particular section is going to take.

5.3 The Updating Procedure

Maintaining an up to date schedule is in the interests of all the parties involved. Every contractor has its own preference. Some prefer to update it on daily basis, some on a weekly basis and some may even consider producing monthly updates. For this project, the schedule was updated on a monthly basis. To facilitate this research, Branch & Associates provided an updated schedule every month. These monthly updates are carried out somewhere in between the 17th to the 24th of each month.

Once these updates were received, they were carefully studied to filter out the completed activities, and the activities, which had an actual start associated with them. Since this research does not use the As-Planned Schedule developed by Branch & Associates, Inc., it was not possible to use their updates directly. Hence, the activities which had progressed had to be updated on the as-planned schedule created for this project.

The activities are updated contemporaneously based on their start and finish dates. Whenever an activity was updated, the schedule was carefully studied to observe its effects on the remaining activities. Only after quantifying the effect of every activity updated in the project schedule was the next activity updated. Therefore, every time an activity is updated, a set of three operations are carried out:

- The corresponding effect on the rest of the activity and the project schedule is studied
- For each activity updated, the start-finish database is appended
- Once the total float for each activity is recorded in the start finish database, the ATF database is appended using the concept of Pre-Allocation of Total Float and the assumptions discussed in Chapter 3

The next activity is updated only after this set of operations is completed for the previous activity.

Once all the activities have been updated, the concept discussed in Section 3.7, which suggests rescheduling the remaining activities to start after the project status date, is used. All the activities, which have not yet started, are rescheduled to start after the project status date for that update. After rescheduling, the new project schedule is studied for its effects on the non-completed activities. Any changes in the Start-Finish dates or the float values are noted down and the corresponding changes are made in the start-finish database and the ATF database. Once these changes have been made, the update is complete and this update serves as a baseline for the next months update.

5.4 The June Update

The June schedule was considered the most appropriate to demonstrate how the concept of Pre-Allocation of Total Float and the bookkeeping procedures are applied to a real construction project. During the month of June 2003, 17 activities were completed and seven activities had an actual start associated with them. In all the other updates, the number of activities updated was so high that it was not feasible to include it in this study.

The first activity to be updated was the “Notice to Proceed.” This activity was delayed from April 15, 2003 by 6 days and was completed on April 21, 2003. Being the first activity, it was obviously critical and caused a delay to the project completion by 6 days. The delay to the notice to proceed causes an increase in float for some of the non-critical activities. As suggested in Section 3.1, this newly created float is treated in the same way as the previously existing float and hence is divided equally between the owner and the contractor. Figure 5-1 represents a section of As-Planned Schedule and Figure 5-2 shows the status as of April 21, 2003. It is not feasible to show all the activities in the figures shown to visualize the effects. Hence, in this chapter, only the figures in which the number of activities is feasible to be shown are presented. These figures show only the activity/activities causing the changes and the activities that are affected.

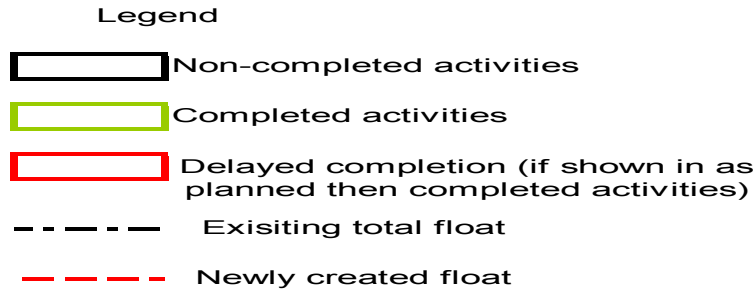

The numbers inside the boxes represent the activity ID and the numbers shown above the dashed lines are the respective float values. An attempt has been made to go through every type of scenario before presenting the result.

The Concept of Pre-Allocation of Total Float: Bookkeeping Procedures

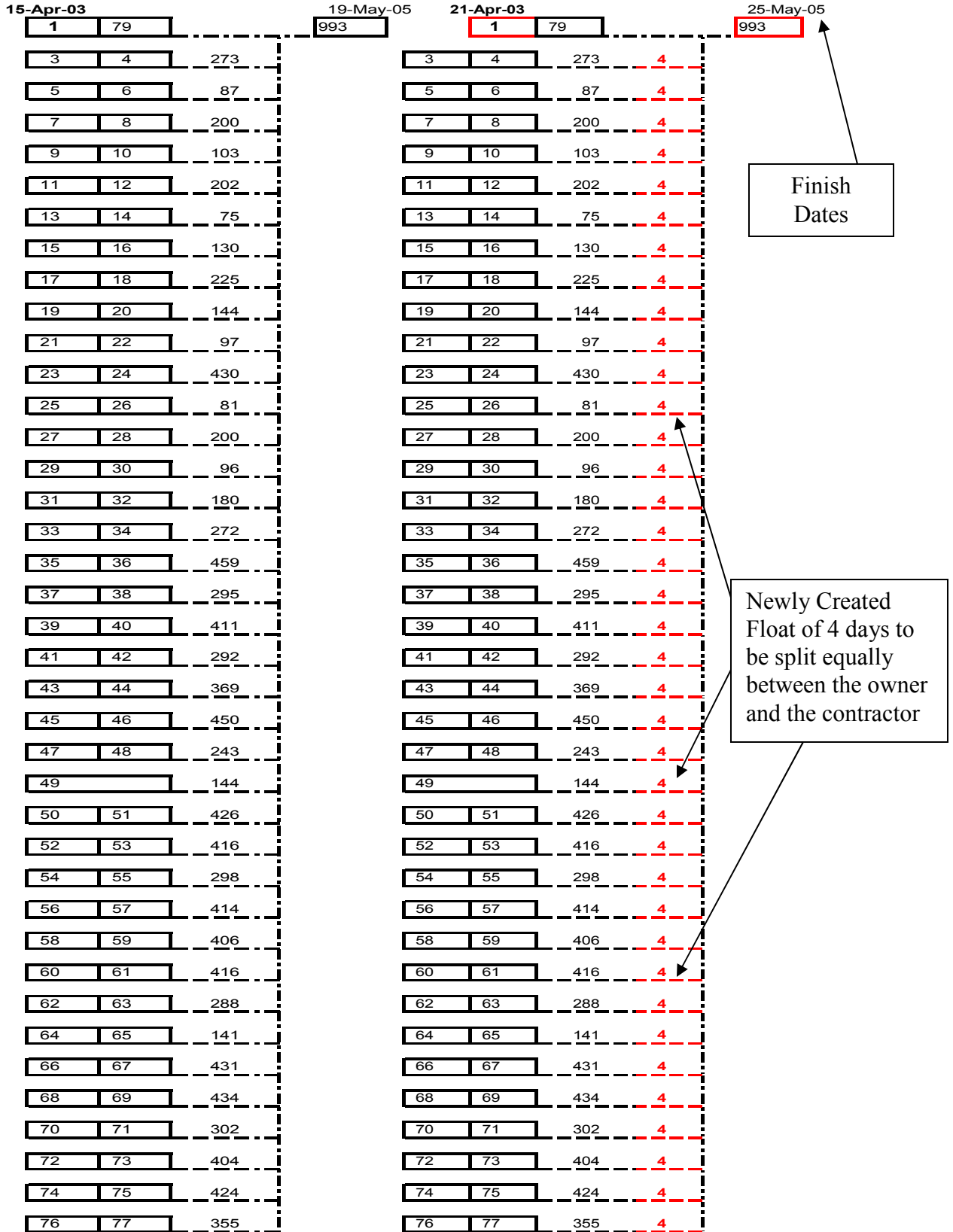

Figure 5-1. Section of As Planned Schedule

Figure 5-2. Section of Update as of April 21, 2003

The Concept of Pre-Allocation of Total Float: Bookkeeping Procedures

The change in the start-finish database can be seen in Table 5-1.

Table 5-1 Section of Start-Finish database for the activities shown in Figures 5-1, 5-2

As Planned			1 [April 21]			
ID	Start	Finish	TF	Start	Finish	TF
1	4/15/2003	4/15/2003	0	4/21/2003	4/21/2003	0
2	4/15/2003	5/29/2003	75	4/15/2003	5/29/2003	79
3	4/15/2003	4/24/2003	273	4/15/2003	4/24/2003	277
4	5/9/2003	5/9/2003	273	5/9/2003	5/9/2003	277
5	4/15/2003	4/15/2003	87	4/15/2003	4/15/2003	91
6	4/30/2003	4/30/2003	87	4/30/2003	4/30/2003	91
7	4/15/2003	4/15/2003	200	4/15/2003	4/15/2003	204
8	4/30/2003	4/30/2003	200	4/30/2003	4/30/2003	204
9	4/15/2003	4/15/2003	103	4/15/2003	4/15/2003	107
10	4/30/2003	4/30/2003	103	4/30/2003	4/30/2003	107
11	4/15/2003	4/15/2003	202	4/15/2003	4/15/2003	206
12	4/30/2003	4/30/2003	202	4/30/2003	4/30/2003	206
13	4/15/2003	4/17/2003	75	4/15/2003	4/17/2003	79
14	5/2/2003	5/2/2003	75	5/2/2003	5/2/2003	79
15	4/15/2003	4/15/2003	130	4/15/2003	4/15/2003	134
16	4/30/2003	4/30/2003	130	4/30/2003	4/30/2003	134
17	4/15/2003	4/15/2003	225	4/15/2003	4/15/2003	229
18	4/30/2003	4/30/2003	225	4/30/2003	4/30/2003	229
19	4/15/2003	4/23/2003	144	4/15/2003	4/23/2003	148
20	5/8/2003	5/8/2003	144	5/8/2003	5/8/2003	148
21	4/15/2003	5/1/2003	97	4/15/2003	5/1/2003	101
22	5/16/2003	5/16/2003	97	5/16/2003	5/16/2003	101
23	4/15/2003	4/15/2003	430	4/15/2003	4/15/2003	434
24	4/30/2003	4/30/2003	430	4/30/2003	4/30/2003	434
25	4/15/2003	4/22/2003	81	4/15/2003	4/22/2003	85
26	5/7/2003	5/7/2003	81	5/7/2003	5/7/2003	85
27	4/15/2003	4/15/2003	200	4/15/2003	4/15/2003	204
28	4/30/2003	4/30/2003	200	4/30/2003	4/30/2003	204
29	4/15/2003	4/17/2003	96	4/15/2003	4/17/2003	100
30	5/2/2003	5/2/2003	96	5/2/2003	5/2/2003	100
31	4/15/2003	4/22/2003	180	4/15/2003	4/22/2003	184
32	5/7/2003	5/7/2003	180	5/7/2003	5/7/2003	184
33	4/15/2003	4/22/2003	272	4/15/2003	4/22/2003	276
34	5/7/2003	5/7/2003	272	5/7/2003	5/7/2003	276
35	4/15/2003	4/15/2003	459	4/15/2003	4/15/2003	463
36	4/30/2003	4/30/2003	459	4/30/2003	4/30/2003	463
37	4/15/2003	4/15/2003	295	4/15/2003	4/15/2003	299
38	4/30/2003	4/30/2003	295	4/30/2003	4/30/2003	299
39	4/15/2003	4/22/2003	411	4/15/2003	4/22/2003	415
40	5/21/2003	5/21/2003	411	5/21/2003	5/21/2003	415
41	4/15/2003	4/15/2003	292	4/15/2003	4/15/2003	296
42	4/30/2003	4/30/2003	292	4/30/2003	4/30/2003	296
43	4/15/2003	4/15/2003	369	4/15/2003	4/15/2003	373
44	4/30/2003	4/30/2003	369	4/30/2003	4/30/2003	373
45	4/15/2003	4/15/2003	450	4/15/2003	4/15/2003	454
46	4/30/2003	4/30/2003	450	4/30/2003	4/30/2003	454
47	4/15/2003	4/15/2003	243	4/15/2003	4/15/2003	247
48	4/30/2003	4/30/2003	243	4/30/2003	4/30/2003	247
49	4/15/2003	4/15/2003	144	4/15/2003	4/15/2003	148
50	4/15/2003	4/15/2003	426	4/15/2003	4/15/2003	430
51	4/30/2003	4/30/2003	426	4/30/2003	4/30/2003	430
52	4/15/2003	4/15/2003	416	4/15/2003	4/15/2003	420
53	4/30/2003	4/30/2003	416	4/30/2003	4/30/2003	420
54	4/15/2003	4/15/2003	298	4/15/2003	4/15/2003	302
55	5/29/2003	5/29/2003	298	5/29/2003	5/29/2003	302
56	4/15/2003	4/15/2003	414	4/15/2003	4/15/2003	418
57	4/30/2003	4/30/2003	414	4/30/2003	4/30/2003	418
58	4/15/2003	4/25/2003	406	4/15/2003	4/25/2003	410
59	5/12/2003	5/12/2003	406	5/12/2003	5/12/2003	410
60	4/15/2003	4/15/2003	416	4/15/2003	4/15/2003	420
61	4/30/2003	4/30/2003	416	4/30/2003	4/30/2003	420
62	4/15/2003	4/15/2003	288	4/15/2003	4/15/2003	292
63	4/30/2003	4/30/2003	288	4/30/2003	4/30/2003	292
64	4/15/2003	4/15/2003	141	4/15/2003	4/15/2003	145
65	4/30/2003	4/30/2003	141	4/30/2003	4/30/2003	145
66	4/15/2003	4/15/2003	431	4/15/2003	4/15/2003	435
67	4/30/2003	4/30/2003	431	4/30/2003	4/30/2003	435
68	4/15/2003	4/15/2003	434	4/15/2003	4/15/2003	438
69	4/30/2003	4/30/2003	434	4/30/2003	4/30/2003	438
70	4/15/2003	4/15/2003	302	4/15/2003	4/15/2003	306
71	4/30/2003	4/30/2003	302	4/30/2003	4/30/2003	306
72	4/15/2003	4/15/2003	404	4/15/2003	4/15/2003	408
73	4/30/2003	4/30/2003	404	4/30/2003	4/30/2003	408
74	4/15/2003	4/15/2003	424	4/15/2003	4/15/2003	428
75	4/30/2003	4/30/2003	424	4/30/2003	4/30/2003	428
76	4/15/2003	4/15/2003	355	4/15/2003	4/15/2003	359
77	4/30/2003	4/30/2003	355	4/30/2003	4/30/2003	359

The numbers highlighted in **red** represent a delay to the activity completion.

The numbers highlighted in **blue** represent a change in the float values.

The numbers highlighted in **yellow** represent the hammock that summarizes all these activities

“1 [April 21]” represents the activity updated (shown in **bold**) and the project status

The corresponding changes in the ATF database can be seen in Table 5-2.

Table 5-2. Section of ATF database for the activities shown in Figures 5-1, 5-2

ID	As Planned			1 [April 21]		
	TF	Owner's ATF	KR's ATF	TF	Owner	KR
1	0	0	0	0	0	0
2	75			79		
3	273	136.5	136.5	277	138.5	138.5
4	273	136.5	136.5	277	138.5	138.5
5	87	43.5	43.5	91	45.5	45.5
6	87	43.5	43.5	91	45.5	45.5
7	200	100	100	204	102	102
8	200	100	100	204	102	102
9	103	51.5	51.5	107	53.5	53.5
10	103	51.5	51.5	107	53.5	53.5
11	202	101	101	206	103	103
12	202	101	101	206	103	103
13	75	37.5	37.5	79	39.5	39.5
14	75	37.5	37.5	79	39.5	39.5
15	130	65	65	134	67	67
16	130	65	65	134	67	67
17	225	112.5	112.5	229	114.5	114.5
18	225	112.5	112.5	229	114.5	114.5
19	144	72	72	148	74	74
20	144	72	72	148	74	74
21	97	48.5	48.5	101	50.5	50.5
22	97	48.5	48.5	101	50.5	50.5
23	430	215	215	434	217	217
24	430	215	215	434	217	217
25	81	40.5	40.5	85	42.5	42.5
26	81	40.5	40.5	85	42.5	42.5
27	200	100	100	204	102	102
28	200	100	100	204	102	102
29	96	48	48	100	50	50
30	96	48	48	100	50	50
31	180	90	90	184	92	92
32	180	90	90	184	92	92
33	272	136	136	276	138	138
34	272	136	136	276	138	138
35	459	229.5	229.5	463	231.5	231.5
36	459	229.5	229.5	463	231.5	231.5
37	295	147.5	147.5	299	149.5	149.5
38	295	147.5	147.5	299	149.5	149.5
39	411	205.5	205.5	415	207.5	207.5
40	411	205.5	205.5	415	207.5	207.5
41	292	146	146	296	148	148
42	292	146	146	296	148	148
43	369	184.5	184.5	373	186.5	186.5
44	369	184.5	184.5	373	186.5	186.5
45	450	225	225	454	227	227
46	450	225	225	454	227	227
47	243	121.5	121.5	247	123.5	123.5
48	243	121.5	121.5	247	123.5	123.5
49	144	72	72	148	74	74
50	426	213	213	430	215	215
51	426	213	213	430	215	215
52	416	208	208	420	210	210
53	416	208	208	420	210	210
54	298	149	149	302	151	151
55	298	149	149	302	151	151
56	414	207	207	418	209	209
57	414	207	207	418	209	209
58	406	203	203	410	205	205
59	406	203	203	410	205	205
60	416	208	208	420	210	210
61	416	208	208	420	210	210
62	288	144	144	292	146	146
63	288	144	144	292	146	146
64	141	70.5	70.5	145	72.5	72.5
65	141	70.5	70.5	145	72.5	72.5
66	431	215.5	215.5	435	217.5	217.5
67	431	215.5	215.5	435	217.5	217.5
68	434	217	217	438	219	219
69	434	217	217	438	219	219
70	302	151	151	306	153	153
71	302	151	151	306	153	153
72	404	202	202	408	204	204
73	404	202	202	408	204	204
74	424	212	212	428	214	214
75	424	212	212	428	214	214
76	355	177.5	177.5	359	179.5	179.5
77	355	177.5	177.5	359	179.5	179.5

The numbers highlighted in blue represent a change in the float values.

The numbers highlighted in yellow represent the hammock that summarizes all these activities

“1 [April 21]” represents the activity updated (shown in bold) and the project status

The Concept of Pre-Allocation of Total Float: Bookkeeping Procedures

The next two activities, i.e., Activities 79 and 86 were completed as per schedule. On April 25, 2003, activities 91 and 92 instead of starting on May 16, 2003, and June 2, 2003, respectively, were both started on April 25, 2003. The status before the start of activities 91 and 92 is as shown in Figure 5.3.

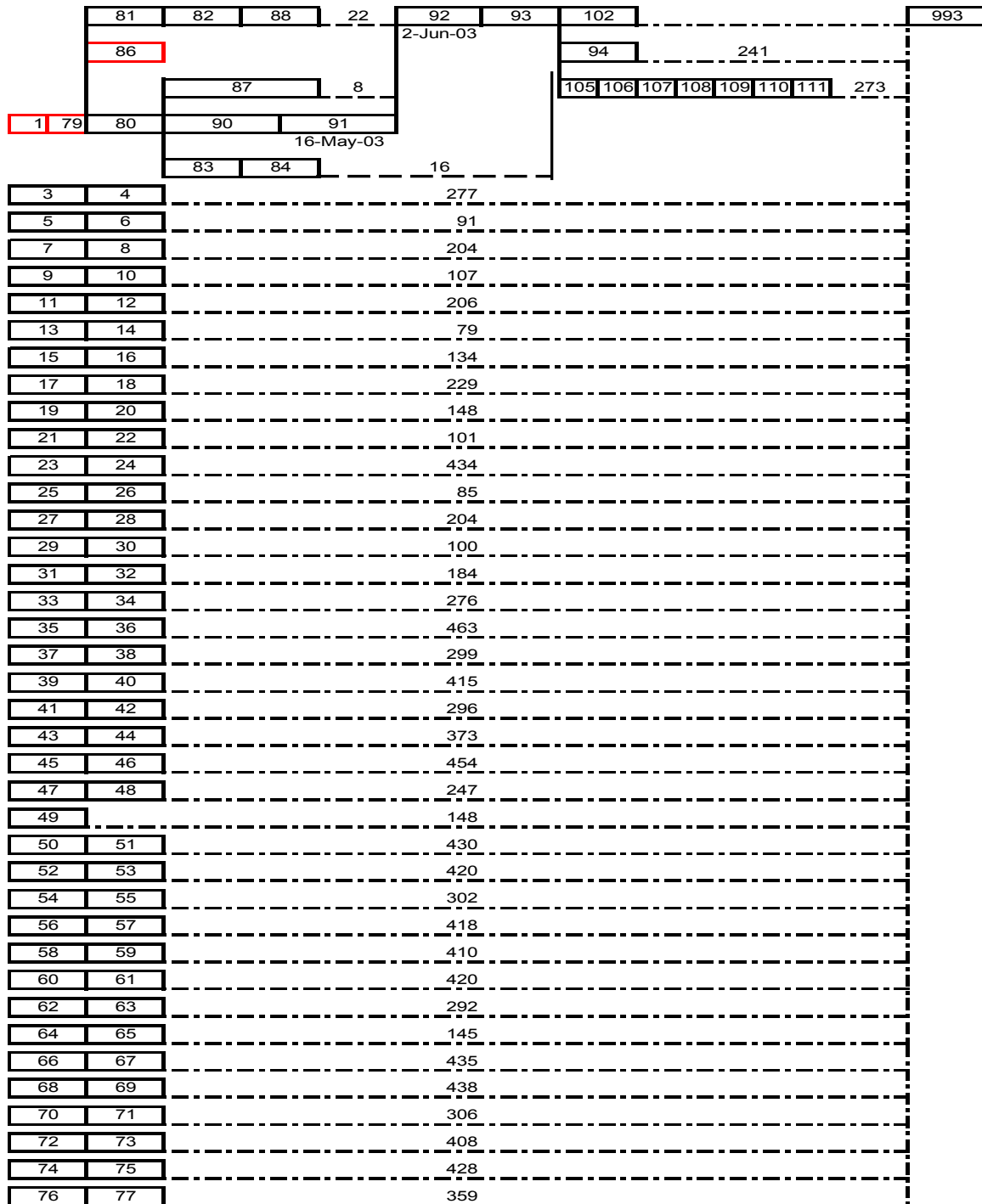

Figure 5-3. Status as of April 24, 2003

The Concept of Pre-Allocation of Total Float: Bookkeeping Procedures

The status as of April 25, 2003, is as shown in figure 5-4.

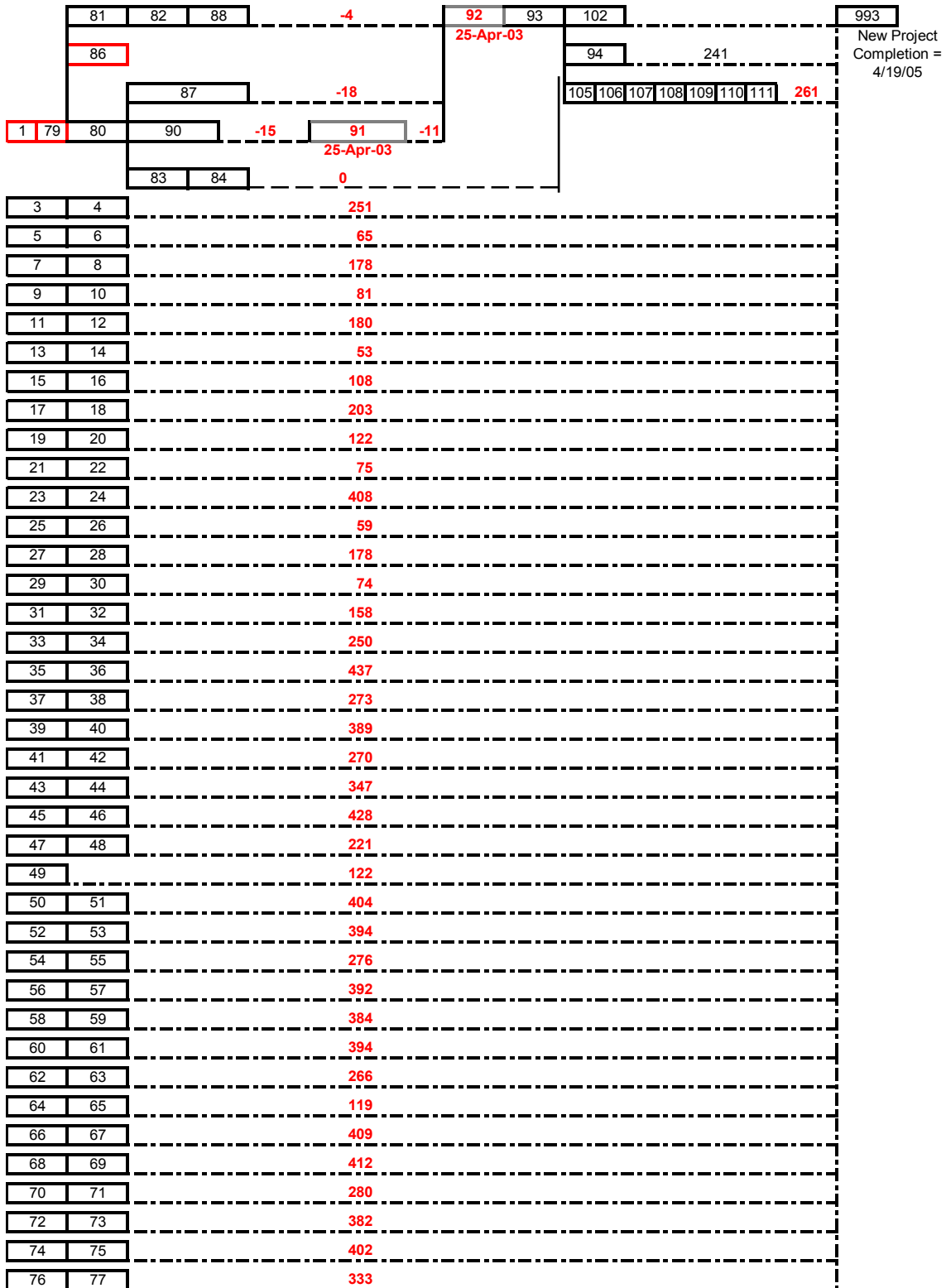

Figure 5-4. Status as of April 25, 2003

Both these activities are critical in nature and hence this acceleration was in the benefit of the project. The estimated project completion now shifts to an earlier date of April 19, 2005 instead of May 25, 2005. This situation of acceleration to a critical activity has already been discussed in Section 3.3. The acceleration causes a reduction in the float value for a number of activities. The new float values are highlighted in red in Figure 5-4. As discussed in Section 3.3, the contractor's ATF value would show a corresponding reduction for these activities. However, since the project is now going to finish early, the contractor is awarded a critical float of $11 + 25 = 36$ days (since the project completion is now April 19, 2005, instead of May 25, 2005) at the end of the project. Hence, at this stage, the contractor owns a critical float of 36 days.

The change in the Start-Finish database and the ATF database can be seen in Tables 5-3 and 5-4, respectively.

In Table 5-3, the numbers highlighted in **red** represent a change in the Start-Finish values of the respective activity. The numbers highlighted in **blue** represent a change to the total float value of the respective activity. The numbers shown in **blue** represent a completed activity.

In Table 5-4, the numbers highlighted in **blue** represent an increase in float. The numbers highlighted in **yellow** represent a decrease in float. The numbers shown in **blue** represent completed activities.

Table 5-3. Section of the Start-Finish database for the activities shown in Fig. 5-3, 5-4

ID	As-Planned			1 [april 21]			86 [April24]			91,92Start [April25]		
	Start	Finish	TF	Start	Finish	TF	Start	Finish	TF	Start	Finish	TF
1	4/15/2003	4/15/2003	0	4/21/2003	4/21/2003	0	4/21/2003	4/21/2003	0	4/21/2003	4/21/2003	0
3	4/15/2003	4/24/2003	273	4/15/2003	4/24/2003	277	4/15/2003	4/24/2003	277	4/15/2003	4/24/2003	251
4	5/9/2003	5/9/2003	273	5/9/2003	5/9/2003	277	5/9/2003	5/9/2003	277	5/9/2003	5/9/2003	251
5	4/15/2003	4/15/2003	87	4/15/2003	4/15/2003	91	4/15/2003	4/15/2003	91	4/15/2003	4/15/2003	65
6	4/30/2003	4/30/2003	87	4/30/2003	4/30/2003	91	4/30/2003	4/30/2003	91	4/30/2003	4/30/2003	65
7	4/15/2003	4/15/2003	200	4/15/2003	4/15/2003	204	4/15/2003	4/15/2003	204	4/15/2003	4/15/2003	178
8	4/30/2003	4/30/2003	200	4/30/2003	4/30/2003	204	4/30/2003	4/30/2003	204	4/30/2003	4/30/2003	178
9	4/15/2003	4/15/2003	103	4/15/2003	4/15/2003	107	4/15/2003	4/15/2003	107	4/15/2003	4/15/2003	81
10	4/30/2003	4/30/2003	103	4/30/2003	4/30/2003	107	4/30/2003	4/30/2003	107	4/30/2003	4/30/2003	81
11	4/15/2003	4/15/2003	202	4/15/2003	4/15/2003	206	4/15/2003	4/15/2003	206	4/15/2003	4/15/2003	180
12	4/30/2003	4/30/2003	202	4/30/2003	4/30/2003	206	4/30/2003	4/30/2003	206	4/30/2003	4/30/2003	180
13	4/15/2003	4/17/2003	75	4/15/2003	4/17/2003	79	4/15/2003	4/17/2003	79	4/15/2003	4/17/2003	53
14	5/2/2003	5/2/2003	75	5/2/2003	5/2/2003	79	5/2/2003	5/2/2003	79	5/2/2003	5/2/2003	53
15	4/15/2003	4/15/2003	130	4/15/2003	4/15/2003	134	4/15/2003	4/15/2003	134	4/15/2003	4/15/2003	108
16	4/30/2003	4/30/2003	130	4/30/2003	4/30/2003	134	4/30/2003	4/30/2003	134	4/30/2003	4/30/2003	108
17	4/15/2003	4/15/2003	225	4/15/2003	4/15/2003	229	4/15/2003	4/15/2003	229	4/15/2003	4/15/2003	203
18	4/30/2003	4/30/2003	225	4/30/2003	4/30/2003	229	4/30/2003	4/30/2003	229	4/30/2003	4/30/2003	203
19	4/15/2003	4/23/2003	144	4/15/2003	4/23/2003	148	4/15/2003	4/23/2003	148	4/15/2003	4/23/2003	122
20	5/8/2003	5/8/2003	144	5/8/2003	5/8/2003	148	5/8/2003	5/8/2003	148	5/8/2003	5/8/2003	122
21	4/15/2003	5/1/2003	97	4/15/2003	5/1/2003	101	4/15/2003	5/1/2003	101	4/15/2003	5/1/2003	75
22	5/16/2003	5/16/2003	97	5/16/2003	5/16/2003	101	5/16/2003	5/16/2003	101	5/16/2003	5/16/2003	75
23	4/15/2003	4/15/2003	430	4/15/2003	4/15/2003	434	4/15/2003	4/15/2003	434	4/15/2003	4/15/2003	408
24	4/30/2003	4/30/2003	430	4/30/2003	4/30/2003	434	4/30/2003	4/30/2003	434	4/30/2003	4/30/2003	408
25	4/15/2003	4/22/2003	81	4/15/2003	4/22/2003	85	4/15/2003	4/22/2003	85	4/15/2003	4/22/2003	59
26	5/7/2003	5/7/2003	81	5/7/2003	5/7/2003	85	5/7/2003	5/7/2003	85	5/7/2003	5/7/2003	59
27	4/15/2003	4/15/2003	200	4/15/2003	4/15/2003	204	4/15/2003	4/15/2003	204	4/15/2003	4/15/2003	178
28	4/30/2003	4/30/2003	200	4/30/2003	4/30/2003	204	4/30/2003	4/30/2003	204	4/30/2003	4/30/2003	178
29	4/15/2003	4/17/2003	96	4/15/2003	4/17/2003	100	4/15/2003	4/17/2003	100	4/15/2003	4/17/2003	74
30	5/2/2003	5/2/2003	96	5/2/2003	5/2/2003	100	5/2/2003	5/2/2003	100	5/2/2003	5/2/2003	74
31	4/15/2003	4/22/2003	180	4/15/2003	4/22/2003	184	4/15/2003	4/22/2003	184	4/15/2003	4/22/2003	158
32	5/7/2003	5/7/2003	180	5/7/2003	5/7/2003	184	5/7/2003	5/7/2003	184	5/7/2003	5/7/2003	158
33	4/15/2003	4/22/2003	272	4/15/2003	4/22/2003	276	4/15/2003	4/22/2003	276	4/15/2003	4/22/2003	250
34	5/7/2003	5/7/2003	272	5/7/2003	5/7/2003	276	5/7/2003	5/7/2003	276	5/7/2003	5/7/2003	250
35	4/15/2003	4/15/2003	459	4/15/2003	4/15/2003	463	4/15/2003	4/15/2003	463	4/15/2003	4/15/2003	437
36	4/30/2003	4/30/2003	459	4/30/2003	4/30/2003	463	4/30/2003	4/30/2003	463	4/30/2003	4/30/2003	437
37	4/15/2003	4/15/2003	295	4/15/2003	4/15/2003	299	4/15/2003	4/15/2003	299	4/15/2003	4/15/2003	273
38	4/30/2003	4/30/2003	295	4/30/2003	4/30/2003	299	4/30/2003	4/30/2003	299	4/30/2003	4/30/2003	273
39	4/15/2003	4/22/2003	411	4/15/2003	4/22/2003	415	4/15/2003	4/22/2003	415	4/15/2003	4/22/2003	389
40	5/21/2003	5/21/2003	411	5/21/2003	5/21/2003	415	5/21/2003	5/21/2003	415	5/21/2003	5/21/2003	389
41	4/15/2003	4/15/2003	292	4/15/2003	4/15/2003	296	4/15/2003	4/15/2003	296	4/15/2003	4/15/2003	270
42	4/30/2003	4/30/2003	292	4/30/2003	4/30/2003	296	4/30/2003	4/30/2003	296	4/30/2003	4/30/2003	270
43	4/15/2003	4/15/2003	369	4/15/2003	4/15/2003	373	4/15/2003	4/15/2003	373	4/15/2003	4/15/2003	347
44	4/30/2003	4/30/2003	369	4/30/2003	4/30/2003	373	4/30/2003	4/30/2003	373	4/30/2003	4/30/2003	347
45	4/15/2003	4/15/2003	450	4/15/2003	4/15/2003	454	4/15/2003	4/15/2003	454	4/15/2003	4/15/2003	428
46	4/30/2003	4/30/2003	450	4/30/2003	4/30/2003	454	4/30/2003	4/30/2003	454	4/30/2003	4/30/2003	428
47	4/15/2003	4/15/2003	243	4/15/2003	4/15/2003	247	4/15/2003	4/15/2003	247	4/15/2003	4/15/2003	221
48	4/30/2003	4/30/2003	243	4/30/2003	4/30/2003	247	4/30/2003	4/30/2003	247	4/30/2003	4/30/2003	221
49	4/15/2003	4/15/2003	144	4/15/2003	4/15/2003	148	4/15/2003	4/15/2003	148	4/15/2003	4/15/2003	122
50	4/15/2003	4/15/2003	426	4/15/2003	4/15/2003	430	4/15/2003	4/15/2003	430	4/15/2003	4/15/2003	404
51	4/30/2003	4/30/2003	426	4/30/2003	4/30/2003	430	4/30/2003	4/30/2003	430	4/30/2003	4/30/2003	404
52	4/15/2003	4/15/2003	416	4/15/2003	4/15/2003	420	4/15/2003	4/15/2003	420	4/15/2003	4/15/2003	394
53	4/30/2003	4/30/2003	416	4/30/2003	4/30/2003	420	4/30/2003	4/30/2003	420	4/30/2003	4/30/2003	394
54	4/15/2003	4/15/2003	298	4/15/2003	4/15/2003	302	4/15/2003	4/15/2003	302	4/15/2003	4/15/2003	276
55	5/29/2003	5/29/2003	298	5/29/2003	5/29/2003	302	5/29/2003	5/29/2003	302	5/29/2003	5/29/2003	276
56	4/15/2003	4/15/2003	414	4/15/2003	4/15/2003	418	4/15/2003	4/15/2003	418	4/15/2003	4/15/2003	392
57	4/30/2003	4/30/2003	414	4/30/2003	4/30/2003	418	4/30/2003	4/30/2003	418	4/30/2003	4/30/2003	392
58	4/15/2003	4/25/2003	406	4/15/2003	4/25/2003	410	4/15/2003	4/25/2003	410	4/15/2003	4/25/2003	384
59	5/12/2003	5/12/2003	406	5/12/2003	5/12/2003	410	5/12/2003	5/12/2003	410	5/12/2003	5/12/2003	384
60	4/15/2003	4/15/2003	416	4/15/2003	4/15/2003	420	4/15/2003	4/15/2003	420	4/15/2003	4/15/2003	394
61	4/30/2003	4/30/2003	416	4/30/2003	4/30/2003	420	4/30/2003	4/30/2003	420	4/30/2003	4/30/2003	394
62	4/15/2003	4/15/2003	288	4/15/2003	4/15/2003	292	4/15/2003	4/15/2003	292	4/15/2003	4/15/2003	266
63	4/30/2003	4/30/2003	288	4/30/2003	4/30/2003	292	4/30/2003	4/30/2003	292	4/30/2003	4/30/2003	266
64	4/15/2003	4/15/2003	141	4/15/2003	4/15/2003	145	4/15/2003	4/15/2003	145	4/15/2003	4/15/2003	119
65	4/30/2003	4/30/2003	141	4/30/2003	4/30/2003	145	4/30/2003	4/30/2003	145	4/30/2003	4/30/2003	119
66	4/15/2003	4/15/2003	431	4/15/2003	4/15/2003	435	4/15/2003	4/15/2003	435	4/15/2003	4/15/2003	409
67	4/30/2003	4/30/2003	431	4/30/2003	4/30/2003	435	4/30/2003	4/30/2003	435	4/30/2003	4/30/2003	409
68	4/15/2003	4/15/2003	434	4/15/2003	4/15/2003	438	4/15/2003	4/15/2003	438	4/15/2003	4/15/2003	412
69	4/30/2003	4/30/2003	434	4/30/2003	4/30/2003	438	4/30/2003	4/30/2003	438	4/30/2003	4/30/2003	412
70	4/15/2003	4/15/2003	302	4/15/2003	4/15/2003	306	4/15/2003	4/15/2003	306	4/15/2003	4/15/2003	280
71	4/30/2003	4/30/2003	302	4/30/2003	4/30/2003	306	4/30/2003	4/30/2003	306	4/30/2003	4/30/2003	280
72	4/15/2003	4/15/2003	404	4/15/2003	4/15/2003	408	4/15/2003	4/15/2003	408	4/15/2003	4/15/2003	382
73	4/30/2003	4/30/2003	404	4/30/2003	4/30/2003	408	4/30/2003	4/30/2003	408	4/30/2003	4/30/2003	382
74	4/15/2003	4/15/2003	424	4/15/2003	4/15/2003	428	4/15/2003	4/15/2003	428	4/15/2003	4/15/2003	402
75	4/30/2003	4/30/2003	424	4/30/2003	4/30/2003	428	4/30/2003	4/30/2003	428	4/30/2003	4/30/2003	402
76	4/15/2003	4/15/2003	355	4/15/2003	4/15/2003	359	4/15/2003	4/15/2003	359	4/15/2003	4/15/2003	333
77	4/30/2003	4/30/2003	355	4/30/2003	4/30/2003	359	4/30/2003	4/30/2003	359	4/30/2003	4/30/2003	333
79	4/16/2003	4/16/2003	0	4/22/2003	4/22/2003	0	4/22/2003	4/22/2003	0	4/22/2003	4/22/2003	0
80	4/17/2003	5/2/2003	0	4/23/2003	5/8/2003	0	4/23/2003	5/8/2003	0	4/23/2003	5/8/2003	-18
81	4/											

Table 5-4. Section of the ATF database for the activities shown in Fig. 5-3, 5-4

ID	As-Planned			1 [april 21]			86 [April24]			91,92Start [April25]		
	TF	Owner	KR	TF	Owner	KR	TF	Owner	KR	TF	Owner	KR
1	0	0	0	0	0	0	0	0	0	0	0	0
3	273	136.5	136.5	277	138.5	138.5	277	138.5	138.5	251	138.5	112.5
4	273	136.5	136.5	277	138.5	138.5	277	138.5	138.5	251	138.5	112.5
5	87	43.5	43.5	91	45.5	45.5	91	45.5	45.5	65	45.5	19.5
6	87	43.5	43.5	91	45.5	45.5	91	45.5	45.5	65	45.5	19.5
7	200	100	100	204	102	102	204	102	102	178	102	76
8	200	100	100	204	102	102	204	102	102	178	102	76
9	103	51.5	51.5	107	53.5	53.5	107	53.5	53.5	81	53.5	27.5
10	103	51.5	51.5	107	53.5	53.5	107	53.5	53.5	81	53.5	27.5
11	202	101	101	206	103	103	206	103	103	180	103	77
12	202	101	101	206	103	103	206	103	103	180	103	77
13	75	37.5	37.5	79	39.5	39.5	79	39.5	39.5	53	39.5	13.5
14	75	37.5	37.5	79	39.5	39.5	79	39.5	39.5	53	39.5	13.5
15	130	65	65	134	67	67	134	67	67	108	67	41
16	130	65	65	134	67	67	134	67	67	108	67	41
17	225	112.5	112.5	229	114.5	114.5	229	114.5	114.5	203	114.5	88.5
18	225	112.5	112.5	229	114.5	114.5	229	114.5	114.5	203	114.5	88.5
19	144	72	72	148	74	74	148	74	74	122	74	48
20	144	72	72	148	74	74	148	74	74	122	74	48
21	97	48.5	48.5	101	50.5	50.5	101	50.5	50.5	75	50.5	24.5
22	97	48.5	48.5	101	50.5	50.5	101	50.5	50.5	75	50.5	24.5
23	430	215	215	434	217	217	434	217	217	408	217	191
24	430	215	215	434	217	217	434	217	217	408	217	191
25	81	40.5	40.5	85	42.5	42.5	85	42.5	42.5	59	42.5	16.5
26	81	40.5	40.5	85	42.5	42.5	85	42.5	42.5	59	42.5	16.5
27	200	100	100	204	102	102	204	102	102	178	102	76
28	200	100	100	204	102	102	204	102	102	178	102	76
29	96	48	48	100	50	50	100	50	50	74	50	24
30	96	48	48	100	50	50	100	50	50	74	50	24
31	180	90	90	184	92	92	184	92	92	158	92	66
32	180	90	90	184	92	92	184	92	92	158	92	66
33	272	136	136	276	138	138	276	138	138	250	138	112
34	272	136	136	276	138	138	276	138	138	250	138	112
35	459	229.5	229.5	463	231.5	231.5	463	231.5	231.5	437	231.5	205.5
36	459	229.5	229.5	463	231.5	231.5	463	231.5	231.5	437	231.5	205.5
37	295	147.5	147.5	299	149.5	149.5	299	149.5	149.5	273	149.5	123.5
38	295	147.5	147.5	299	149.5	149.5	299	149.5	149.5	273	149.5	123.5
39	411	205.5	205.5	415	207.5	207.5	415	207.5	207.5	389	207.5	181.5
40	411	205.5	205.5	415	207.5	207.5	415	207.5	207.5	389	207.5	181.5
41	292	146	146	296	148	148	296	148	148	270	148	122
42	292	146	146	296	148	148	296	148	148	270	148	122
43	369	184.5	184.5	373	186.5	186.5	373	186.5	186.5	347	186.5	160.5
44	369	184.5	184.5	373	186.5	186.5	373	186.5	186.5	347	186.5	160.5
45	450	225	225	454	227	227	454	227	227	428	227	201
46	450	225	225	454	227	227	454	227	227	428	227	201
47	243	121.5	121.5	247	123.5	123.5	247	123.5	123.5	221	123.5	97.5
48	243	121.5	121.5	247	123.5	123.5	247	123.5	123.5	221	123.5	97.5
49	144	72	72	148	74	74	148	74	74	122	74	48
50	426	213	213	430	215	215	430	215	215	404	215	189
51	426	213	213	430	215	215	430	215	215	404	215	189
52	416	208	208	420	210	210	420	210	210	394	210	184
53	416	208	208	420	210	210	420	210	210	394	210	184
54	298	149	149	302	151	151	302	151	151	276	151	125
55	298	149	149	302	151	151	302	151	151	276	151	125
56	414	207	207	418	209	209	418	209	209	392	209	183
57	414	207	207	418	209	209	418	209	209	392	209	183
58	406	203	203	410	205	205	410	205	205	384	205	179
59	406	203	203	410	205	205	410	205	205	384	205	179
60	416	208	208	420	210	210	420	210	210	394	210	184
61	416	208	208	420	210	210	420	210	210	394	210	184
62	288	144	144	292	146	146	292	146	146	266	146	120
63	288	144	144	292	146	146	292	146	146	266	146	120
64	141	70.5	70.5	145	72.5	72.5	145	72.5	72.5	119	72.5	46.5
65	141	70.5	70.5	145	72.5	72.5	145	72.5	72.5	119	72.5	46.5
66	431	215.5	215.5	435	217.5	217.5	435	217.5	217.5	409	217.5	191.5
67	431	215.5	215.5	435	217.5	217.5	435	217.5	217.5	409	217.5	191.5
68	434	217	217	438	219	219	438	219	219	412	219	193
69	434	217	217	438	219	219	438	219	219	412	219	193
70	302	151	151	306	153	153	306	153	153	280	153	127
71	302	151	151	306	153	153	306	153	153	280	153	127
72	404	202	202	408	204	204	408	204	204	382	204	178
73	404	202	202	408	204	204	408	204	204	382	204	178
74	424	212	212	428	214	214	428	214	214	402	214	188
75	424	212	212	428	214	214	428	214	214	402	214	188
76	355	177.5	177.5	359	179.5	179.5	359	179.5	179.5	333	179.5	153.5
77	355	177.5	177.5	359	179.5	179.5	359	179.5	179.5	333	179.5	153.5
79	0	0	0	0	0	0	0	0	0	0	0	0
80	0	0	0	0	0	0	0	0	0	-18	0	-18
81	22	11	11	22	11	11	22	11	11	-4	11	-15
82	22	11	11	22	11	11	22	11	11	-4	11	-15
83	287	143.5	143.5	287	143.5	143.5	287	143.5	143.5	261	143.5	117.5
84	287	143.5	143.5	287	143.5	143.5	287	143.5	143.5	261	143.5	117.5
86	26	13	13	26	13	13	0	0	0	0	0	0
87	8	4	4	8	4	4	8	4	4	-18	4	-22
88	22	11	11	22	11	11	22	11	11	-4	11	-15
90	0	0	0	0	0	0	0	0	0	-15	0	-15
91	0	0	0	0	0	0	0	0	0	-11	0	-11
92	0	0	0	0	0	0	0	0	0	0	0	0
93	0	0	0	0	0	0	0	0	0	0	0	0
94	241	120.5	120.5	241	120.5	120.5	241	120.5	120.5	241	120.5	120.5
102	0	0	0	0	0	0	0	0	0	0	0	0
105	273	136.5	136.5	273	136.5	136.5	273	136.5	136.5	261	136.5	124.5
106	273	136.5	136.5	273	136.5	136.5	273	136.5	136.5	261	136.5	124.5
107	273	136.5	136.5	273	136.5	136.5	273	136.5	136.5	261	136.5	124.5
108	273	136.5	136.5	273	136.5	136.5	273	136.5	136.5	261	136.5	124.5
109	273	136.5	136.5	273	136.5	136.5	273	136.5	136.5	261	136.5	124.5
110	273	136.5	136.5	273	136.5	136.5	273	136.5	136.5	261	136.5	124.5
111	273	136.5	136.5	273	136.5	136.5	273	136.5	136.5	261	136.5	124.5

The next significant update was the completion of activity 82. This activity was initially scheduled to start on April 24, 2003 but was delayed. The early start of activities 91 and 92 as discussed in the previous case, has already made activity 82 critical. In fact, as can be seen in Tables 5-3 and 5-4, the total float on this activity as of April 25, 2003 is “-4” which means that it is already delayed by 4 days. Activity 82 is now completed on May 7, 2003. The status before the start of activity 82 is as shown in the figure 5-5.

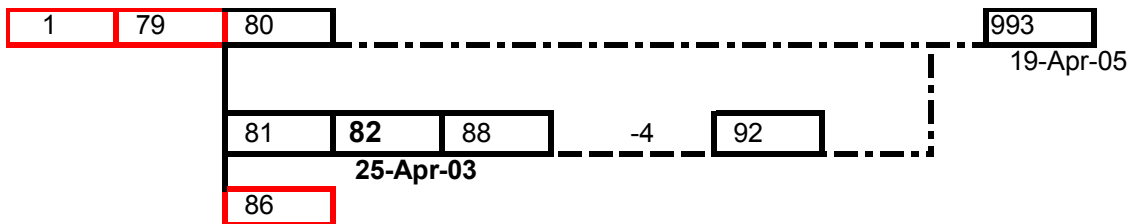

Figure 5-5. Project Status before start of activity 82

Activity 81 has a finish-to-start relationship with activity 82. Activity 82 is completed out-of-sequence before activity 81. This situation of out of sequence progress has been discussed in Section 3.5. Branch and Associates uses Microsoft Project® to maintain their project schedule. For out of sequence progress, this software adopts the concept of progress override (discussed in Section 3.5.2). The status is as shown in Figure 5-6.

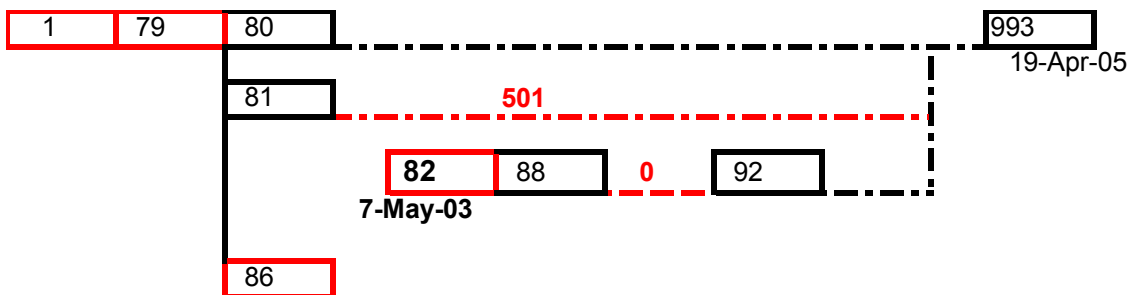

Figure 5-6. Status after completion of Activity 82

Since activity 82 was completed before activity 81, the start of activities 88, 92, and the rest of the activities in that path is no longer linked to the completion of activity 81. The finish to start link between activity 81 and 82 is broken and now activity 81 no longer has an immediate successor. Hence, it suddenly has a total float of 501 days. This is newly created float and is allocated equally between the owner and the contractor.

The rest of the updates in the June schedule were similar to the cases discussed above. For each case, the party responsible was determined and the respective party was held responsible for whatever effects an activity had on the following activities, if any. It is not feasible to show the variations in the Start-Finish database and the ATF databases for each activity. Hence, to explain how these changes are shown in the respective databases, a fragnet of activities is selected and their behavior is presented. Consider the fragnet shown in Figure 5-7.

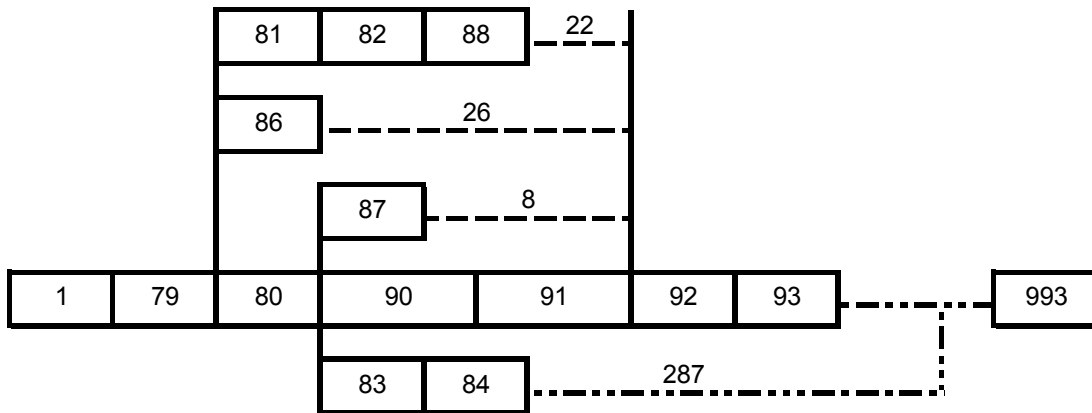

Figure 5-7. Section of the As-Planned Schedule

The section of the Start-Finish database representing the activities in Figure 5-7 is as shown in Table 5-5.

Table 5-5: Section of Start-Finish database for activities shown in Figure 5-7

ID	Start	Finish	TF
1	4/15/2003	4/15/2003	0
78	4/16/2003	5/19/2003	0
79	4/16/2003	4/16/2003	0
80	4/17/2003	5/2/2003	0
81	4/17/2003	4/17/2003	22
82	4/18/2003	4/21/2003	22
83	5/5/2003	5/19/2003	287
84	5/19/2003	5/19/2003	287
85	4/17/2003	5/14/2003	8
86	4/17/2003	4/18/2003	26
87	5/5/2003	5/14/2003	8
88	4/22/2003	4/24/2003	22
89	5/5/2003	7/29/2003	0
90	5/5/2003	5/9/2003	0
91	5/12/2003	5/27/2003	0
92	5/27/2003	5/27/2003	0
93	5/28/2003	6/9/2003	0
993	5/19/2005	5/19/2005	0

The corresponding ATF database is as shown in Table 5-6.

Table 5-6: ATF database for activities shown in Figure 5-7

ID	TF	Owner	KR
1	0	0	0
78	0		
79	0	0	0
80	0	0	0
81	22	11	11
82	22	11	11
83	287	143.5	143.5
84	287	143.5	143.5
85	8		
86	26	13	13
87	8	4	4
88	22	11	11
89	0		
90	0	0	0
91	0	0	0
92	0	0	0
93	0	0	0
993	0	0	0

The delay to activity 1 delays the start of all the activities. There is no change in the float values. The Start-Finish database is as shown in Table 5-7.

Table 5-7. Start-Finish database after Activity 1 is delayed

As Planned				1 [April 21]		
ID	Start	Finish	TF	Start	Finish	TF
1	4/15/2003	4/15/2003	0	4/21/2003	4/21/2003	0
78	4/16/2003	5/19/2003	0	4/22/2003	5/23/2003	0
79	4/16/2003	4/16/2003	0	4/22/2003	4/22/2003	0
80	4/17/2003	5/2/2003	0	4/23/2003	5/8/2003	0
81	4/17/2003	4/17/2003	22	4/23/2003	4/23/2003	22
82	4/18/2003	4/21/2003	22	4/24/2003	4/25/2003	22
83	5/5/2003	5/19/2003	287	5/9/2003	5/23/2003	287
84	5/19/2003	5/19/2003	287	5/23/2003	5/23/2003	287
85	4/17/2003	5/14/2003	8	4/23/2003	5/20/2003	8
86	4/17/2003	4/18/2003	26	4/23/2003	4/24/2003	26
87	5/5/2003	5/14/2003	8	5/9/2003	5/20/2003	8
88	4/22/2003	4/24/2003	22	4/28/2003	4/30/2003	22
89	5/5/2003	7/29/2003	0	5/9/2003	8/4/2003	0
90	5/5/2003	5/9/2003	0	5/9/2003	5/15/2003	0
91	5/12/2003	5/27/2003	0	5/16/2003	6/2/2003	0
92	5/27/2003	5/27/2003	0	6/2/2003	6/2/2003	0
93	5/28/2003	6/9/2003	0	6/3/2003	6/13/2003	0
993	5/19/2005	5/19/2005	0	5/25/2005	5/25/2005	0

Table 5-8: Start-Finish database as of April 25, 2003

ID	As Planned			1 [April 21, 2003]			91,92Start [April 25, 2003]		
	Start	Finish	TF	Start	Finish	TF	Start	Finish	TF
1	4/15/2003	4/15/2003	0	4/21/2003	4/21/2003	0	4/21/2003	4/21/2003	0
78	4/16/2003	5/19/2003	0	4/22/2003	5/23/2003	0	4/22/2003	5/23/2003	261
79	4/16/2003	4/16/2003	0	4/22/2003	4/22/2003	0	4/22/2003	4/22/2003	0
80	4/17/2003	5/2/2003	0	4/23/2003	5/8/2003	0	4/23/2003	5/8/2003	-18
81	4/17/2003	4/17/2003	22	4/23/2003	4/23/2003	22	4/23/2003	4/23/2003	-4
82	4/18/2003	4/21/2003	22	4/24/2003	4/25/2003	22	4/24/2003	4/25/2003	-4
83	5/5/2003	5/19/2003	287	5/9/2003	5/23/2003	287	5/9/2003	5/23/2003	261
84	5/19/2003	5/19/2003	287	5/23/2003	5/23/2003	287	5/23/2003	5/23/2003	261
85	4/17/2003	5/14/2003	8	4/23/2003	5/20/2003	8	4/23/2003	5/20/2003	-18
86	4/17/2003	4/18/2003	26	4/23/2003	4/24/2003	26	4/23/2003	4/24/2003	0
87	5/5/2003	5/14/2003	8	5/9/2003	5/20/2003	8	5/9/2003	5/20/2003	-18
88	4/22/2003	4/24/2003	22	4/28/2003	4/30/2003	22	4/28/2003	4/30/2003	-4
89	5/5/2003	7/29/2003	0	5/9/2003	8/4/2003	0	4/25/2003	6/26/2003	241
90	5/5/2003	5/9/2003	0	5/9/2003	5/15/2003	0	5/9/2003	5/15/2003	-15
91	5/12/2003	5/27/2003	0	5/16/2003	6/2/2003	0	4/25/2003	5/9/2003	-11
92	5/27/2003	5/27/2003	0	6/2/2003	6/2/2003	0	4/25/2003	4/25/2003	0
93	5/28/2003	6/9/2003	0	6/3/2003	6/13/2003	0	4/25/2003	5/7/2003	0
993	5/19/2005	5/19/2005	0	5/25/2005	5/25/2005	0	4/19/2005	4/19/2005	0

The corresponding ATF database is as shown in Table 5-9.

Table 5-9: ATF database as of April 25, 2003

ID	As Planned			1 [April 21, 2003]			91,92Start [April 25, 2003]		
	TF	Owner	KR	TF	Owner	KR	TF	Owner	KR
1	0	0	0	0	0	0	0	0	0
78	0			0			261		
79	0	0	0	0	0	0	0	0	0
80	0	0	0	0	0	0	-18	0	-18
81	22	11	11	22	11	11	-4	11	-15
82	22	11	11	22	11	11	-4	11	-15
83	287	143.5	143.5	287	143.5	143.5	261	143.5	117.5
84	287	143.5	143.5	287	143.5	143.5	261	143.5	117.5
85	8			8			-18		
86	26	13	13	26	13	13	0	0	0
87	8	4	4	8	4	4	-18	4	-22
88	22	11	11	22	11	11	-4	11	-15
89	0			0			241		
90	0	0	0	0	0	0	-15	0	-15
91	0	0	0	0	0	0	-11	0	-11
92	0	0	0	0	0	0	0	0	0
93	0	0	0	0	0	0	0	0	0
993	0	0	0	0	0	0	0	0	0

The numbers highlighted in blue in Table 5-7 indicate an increase in the float value whereas the numbers in yellow indicate a decrease in the float value. The contractor had accelerated the start of activities 91 and 92. This led to a decrease in total float values for the respective activities shown in Table 5-7. The contractor is held responsible for this reduction and hence the negative values in the contractor (KR)

column. The owners ATF remain the same. Since this delay causes the projected completion date to be before schedule, the contractor is also awarded critical float for the project as shown in Figure 5-8. This critical float is not shown in the ATF database but is kept track of separately.

The next update is on April 29, 2003, when Activity 87 is started before schedule. The status is as shown in Figure 5-9.

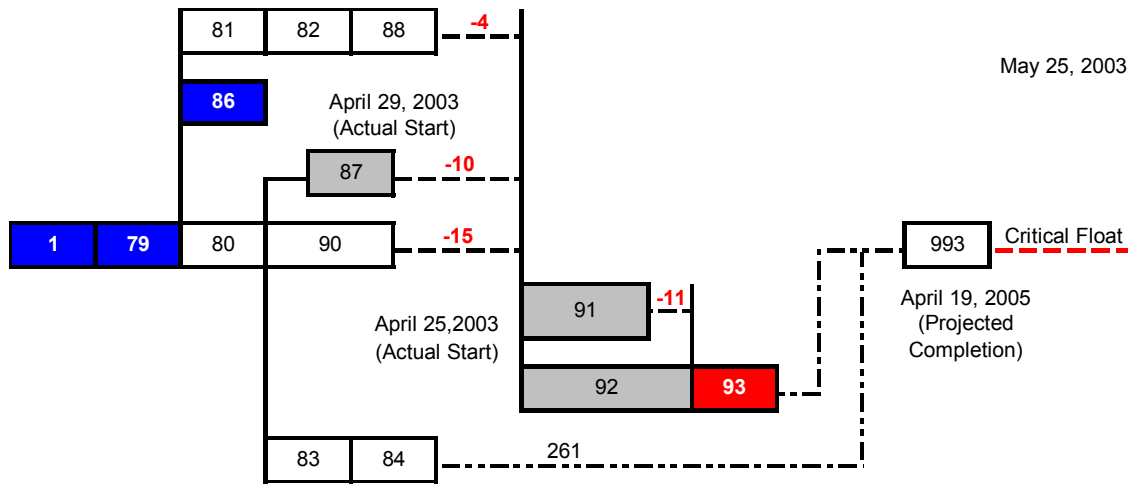

Figure 5-9. Status as of April 29, 2003

Table 5-10: Start-Finish Database as of April 29, 2003

ID	As Planned			1 [April 21, 2003]			91,92Start [April 25, 2003]			87Start [April 29]		
	Start	Finish	TF	Start	Finish	TF	Start	Finish	TF	Start	Finish	TF
1	4/15/2003	4/15/2003	0	4/21/2003	4/21/2003	0	4/21/2003	4/21/2003	0	4/21/2003	4/21/2003	0
78	4/16/2003	5/19/2003	0	4/22/2003	5/23/2003	0	4/22/2003	5/23/2003	261	4/22/2003	5/23/2003	261
79	4/16/2003	4/16/2003	0	4/22/2003	4/22/2003	0	4/22/2003	4/22/2003	0	4/22/2003	4/22/2003	0
80	4/17/2003	5/2/2003	0	4/23/2003	5/8/2003	0	4/23/2003	5/8/2003	-18	4/23/2003	5/8/2003	-15
81	4/17/2003	4/17/2003	22	4/23/2003	4/23/2003	22	4/23/2003	4/23/2003	-4	4/23/2003	4/23/2003	-4
82	4/18/2003	4/21/2003	22	4/24/2003	4/25/2003	22	4/24/2003	4/25/2003	-4	4/24/2003	4/25/2003	-4
83	5/5/2003	5/19/2003	287	5/9/2003	5/23/2003	287	5/9/2003	5/23/2003	261	5/9/2003	5/23/2003	261
84	5/19/2003	5/19/2003	287	5/23/2003	5/23/2003	287	5/23/2003	5/23/2003	261	5/23/2003	5/23/2003	261
85	4/17/2003	5/14/2003	8	4/23/2003	5/20/2003	8	4/23/2003	5/20/2003	-18	4/23/2003	5/8/2003	0
86	4/17/2003	4/18/2003	26	4/23/2003	4/24/2003	26	4/23/2003	4/24/2003	0	4/23/2003	4/24/2003	0
87	5/5/2003	5/14/2003	8	5/9/2003	5/20/2003	8	5/9/2003	5/20/2003	-18	4/29/2003	5/8/2003	-10
88	4/22/2003	4/24/2003	22	4/28/2003	4/30/2003	22	4/28/2003	4/30/2003	-4	4/28/2003	4/30/2003	-4
89	5/5/2003	7/29/2003	0	5/9/2003	8/4/2003	0	4/25/2003	6/26/2003	241	4/25/2003	6/26/2003	241
90	5/5/2003	5/9/2003	0	5/9/2003	5/15/2003	0	5/9/2003	5/15/2003	-15	5/9/2003	5/15/2003	-15
91	5/12/2003	5/27/2003	0	5/16/2003	6/2/2003	0	4/25/2003	5/9/2003	-11	4/25/2003	5/9/2003	-11
92	5/27/2003	5/27/2003	0	6/2/2003	6/2/2003	0	4/25/2003	4/25/2003	0	4/25/2003	4/25/2003	0
93	5/28/2003	6/9/2003	0	6/3/2003	6/13/2003	0	4/25/2003	5/7/2003	0	4/25/2003	5/7/2003	0
993	5/19/2005	5/19/2005	0	5/25/2005	5/25/2005	0	4/19/2005	4/19/2005	0	4/19/2005	4/19/2005	0

Table 5-11: Corresponding ATF database as of April 29, 2003

ID	As Planned			1 [April 21, 2003]			91,92Start [April 25, 2003]			87Start [April29]		
	TF	Owner	KR	TF	Owner	KR	TF	Owner	KR	TF	Owner	KR
1	0	0	0	0	0	0	0	0	0	0	0	0
78	0			0			261			261		
79	0	0	0	0	0	0	0	0	0	0	0	0
80	0	0	0	0	0	0	-18	0	-18	-15	0	-15
81	22	11	11	22	11	11	-4	11	-15	-4	11	-15
82	22	11	11	22	11	11	-4	11	-15	-4	11	-15
83	287	143.5	143.5	287	143.5	143.5	261	143.5	117.5	261	143.5	117.5
84	287	143.5	143.5	287	143.5	143.5	261	143.5	117.5	261	143.5	117.5
85	8			8			-18			0		
86	26	13	13	26	13	13	0	0	0	0	0	0
87	8	4	4	8	4	4	-18	4	-22	-10	4	-14
88	22	11	11	22	11	11	-4	11	-15	-4	11	-15
89	0			0			241			241		
90	0	0	0	0	0	0	-15	0	-15	-15	0	-15
91	0	0	0	0	0	0	-11	0	-11	-11	0	-11
92	0	0	0	0	0	0	0	0	0	0	0	0
93	0	0	0	0	0	0	0	0	0	0	0	0
993	0	0	0	0	0	0	0	0	0	0	0	0

Since, activity 87 is started before schedule its float increases from -18 to -10. This increase in float could be considered as newly created float and should have been divided equally between the owner and contractor as discussed in Section 3.3. Nevertheless, for the sake of simplicity, in case of negative floats it is assumed that any newly created float would be awarded to the party causing it. Hence, in this case the owner's ATF still remains the same even though there is an increase in total float for some associated activities.

The project schedule is updated in a similar fashion until all the activities have been addressed. Once all the activities have been addressed, the remaining activities that were supposed to start in this month, but were not started, are rescheduled to start after the project status date, i.e., June 24, 2003 in this case. The Start-Finish database showing the initial As-Planned schedule, status as of June 20, 2003, and the status after rescheduling the remaining activities is as shown in Appendix B. The corresponding ATF database is as shown in Appendix C.

Summarizing the major occurrences in the June update, the contractor accelerated the start of activities 91 and 92, which provided the contractor with a critical float of 36 days (instead of May 25, 2005 → April 19, 2005). The contractor then delayed the completion of activities 81 and 92, which delayed the project completion from April 19, 2005 to May 6, 2005. Hence, the contractor still has critical float of $36 - 17 = 19$ days. The contractor then delayed the start of activities 93 and 114, which further delayed the project by 6 days. The project is scheduled to complete on May 12, 2005. The contractor still has a critical float of $19 - 6 = 13$ days. The contractor then accelerates the completion of Activity 237, which results in a critical float of 17 days (project completion becomes April 25, 2005 instead of May 12, 2005). Hence, total critical float owned by the contractor is $13 + 17 = 30$ days. The contractor then delays the start of activity 238, which delays the project completion to April 29, 2005. The contractor now has a critical float of $30 - 4 = 26$ days. Until June 20, 2003, the project completion was scheduled as April 29, 2005. Once the remaining activities were rescheduled to start on June 24, 2003 (the project status date, i.e., date when the update was carried out), the completion is delayed and is now scheduled to May 9, 2005. The rescheduled activities are identified to be the responsibility of the contractor. Hence, the contractor loses 10 more days and is now left with 20 days of critical float.

The updated Start-Finish database and the ATF database are as shown in Appendix B and Appendix C, respectively. It is not feasible to show the individual updates and corresponding effects for each activity. Therefore, only the As-Planned status as of June 20, 2003 (just before rescheduling), and the status after rescheduling have been presented.

5.5 Insights and Chapter Conclusions

Chapter 4 presented a generic methodology to apply the concept of Pre-Allocation of Total Float. This procedure applies to any project schedule to monitor the ATF values for the corresponding parties. With a few modifications to incorporate the contractor's style of scheduling, this method can be used effectively as a bookkeeping procedure to implement the concept of Pre-Allocation of Total Float. Chapter 5 shows how this concept of Pre-Allocation of Total Float applies to the contractor – specific (in this case-Branch & Associates, Inc.) method of scheduling.

As can be seen from its application and results, this concept of Pre-Allocation of Total float respects the dynamic nature of construction projects and recognizes total float to be an asset to both parties. The concept makes sure that the parties realize that if they use float in a project, they can be exposed to potential damages. The benefits of this concept are summarized as follows:

- Pre allocates a specific amount of total float at the start of the project for each party. The parties are hence aware of the number of days of float they own at the start of the project and therefore can plan and implement their activities in a corresponding manner.
- Easier to allocate responsibilities to parties causing delays. This will reduce the chances of disputes and claims.
- Equitable and fair to the parties to the contract
- Necessitates need to monitor schedule closely, and hence facilitates better project management.

The bookkeeping procedures developed in this research facilitate the application of the concept of Pre-Allocation of Total Float. Even after developing the bookkeeping procedures and demonstrating how these can be used to apply the concept of Pre-Allocation of Total Float, the ease of implementation and the associated costs remains a concern.

Without computer support, the parties to the contract would need to assign one personnel to carry out the updating process manually. This process becomes very cumbersome and at times unmanageable when it comes to complex projects like the ACECHC project. The cost of keeping track of the project schedule manually would be quite large and hence this is not at all practical for the construction industry. Hence, implementing the concept of Pre-Allocation of Total Float under the current circumstances is not only difficult to implement, but can also be deemed as very expensive.

The only way this can be made feasible is by automating the process of updating the Start-Finish database and the ATF database. The solution to the above problem would be to develop an independent computer program or an add-in to existing scheduling software, which can filter out the required information on real time basis from the project schedule, update the Start-Finish database and the ATF database automatically and then keep track of the respective ATF values. The program can be customized to the needs of the user as well.

An easy implementation of the concept of Pre-Allocation of Total Float might save the industry from the constantly increasing costs of delay claims and court cases. Automating the process would not be too difficult and in the future would prove to be cost effective. This will definitely require some initial investment in developing a computer program. Once this is developed, the implementation of this concept will effectively be similar to carrying out regular updates.

Once this process of bookkeeping is automated, the application of the concept of Pre-Allocation of Total Float will pay for itself as the additional costs of disputes and delayed project completion can be avoided or minimized.

Chapter 6

Conclusions and Recommendations

Due to the ambiguous nature of its interpretation, float ownership has become one of the key areas of disputes between the parties in the contract. The concept of Pre-Allocation of Total Float (Prateapusanond 2003) is an effort towards a fair and equitable system for float allocation. This concept respects the dynamic nature of construction projects and recognizes total float to be an asset to both parties. Therefore, the participating parties share the risk of unforeseen circumstances equally. The concept pre-allocates a set amount of total float on the same non-critical path of activities to two contractual parties – the owner and the contractor. Under this plan, equal allocation of total float ensures that the owner and the contractor each own one-half of the total float available on any non-critical path activity of the project (Prateapusanond 2003).

This research aimed at testing the practicality of the concept of Pre-Allocation of Total Float.” The concept appears to be very appealing on paper, but necessitates the need to monitor the schedule closely, keep track of the float used by each party, and the ATF owned by each party. Hence, the main objective of this research was to develop bookkeeping procedures that would facilitate keeping track of the ATF values for each activity and help us monitor the schedule closely. Scheduling can pose different situations and each situation poses a different challenge. Construction being a diversified industry, the nature of schedules varies with every project. Therefore, it is important to see whether the concept of Pre-Allocation of Total Float has the capability to handle the scheduling games and problems, which are very common to this industry.

6.1 Conclusions

The main aim of this thesis was to develop bookkeeping procedures that would facilitate monitoring a project schedule closely as well as help in keeping track of the allowable total float for the owner and the contractor. The objectives achieved by this research can be summarized as below:

- This research highlights the different scheduling problems that occur during complex scheduling which are not addressed to, by the concept of Pre-Allocation of Total Float. Specific assumptions have been made for each problem, which were discussed in detail in Chapter 3. The combination of the concept of Pre-Allocation of Total Float and these assumptions makes this concept robust in nature. The solutions are merely logical assumptions and hence can vary with a different perspective.
- The bookkeeping procedures required to apply the concept of Pre-Allocation of Total Float have been successfully developed. This research recommends the use of two databases; namely, the Start-Finish database and the Allowable Total Float (ATF) database. Again, with a different perspective some may also consider combining the two databases into one single database.
- The bookkeeping procedures used in this research can be used as an algorithm to develop a computer program.
- Demonstrates the applicability of the concept of Pre-Allocation of Total Float on a complex project schedule.

6.2 Areas of Future Research

The concept of Pre-Allocation of Total Float is an effort towards a more fair and equitable system of float allocation. The successful application of this concept requires the user to monitor the schedule closely and keep track of the ATF of each party for each activity in the schedule. The bookkeeping procedures developed can successfully be used to achieve this purpose, even for complex schedules. During the course of this research, several scheduling problems were encountered, which the concept of Pre-Allocation of Total Float did not address. To continue with developing bookkeeping procedures and to test its applicability on schedules, appropriate logical assumptions were made. These assumptions seem to address all the scheduling problems faced and ensured complete applicability of the concept of Pre-Allocation of Total Float to the ACECHC project schedule. Nevertheless, with different assumptions, other solutions are also possible. Therefore, one of the areas for future research would be to identify and develop generic solutions, which are based on concrete data so that their applicability cannot be questioned.

The concept of Pre-Allocation of Total Float recommends an equal allocation of total float amongst the parties. Total float can never be a fraction and therefore the ATF value should not be a fraction as well. In case an activity has a total float, which is an odd number, an equal allocation would mean that the ATF value would be a decimal value. This is against the scheduling norms followed by the industry and is not endorsed by the courts. The application of the concept of Pre-Allocation of Total Float is not possible unless this area is addressed. Future research is recommended to resolve this issue of fractional float values.

The bookkeeping procedures developed require the user to append the Start-Finish database and the ATF database for each activity updated. In the case of complex schedules like the ACECHC project schedule, which consists of over 900 activities, appending the database for each activity becomes very cumbersome. The concept of Pre-Allocating Total Float refutes the proximate cause concept, which is endorsed by the courts. The proximate cause concept considers the party that was the proximate cause for

the delay to be responsible for the delay. Hence, it would require a complete rethinking of an already accepted float ownership principle. The success of the concept of Pre-Allocating Total Float thus most importantly depends on its ease of implementation. If the cycle of operations as discussed in Section 5.3 were to be done for each activity manually, then it would be very difficult to implement the concept of Pre-Allocation of Total Float. This research thus recommends the need to develop a computer program, which could filter out the updated activities and the relevant data from the project schedule itself on real time basis. It could be either an independent program or an add-in for the existing scheduling packages. The development of such a program would make the process of keeping track of the schedule and ATF values more convenient. The program could also be customized to the needs of the parties using it.

During the application of Pre-Allocation of Total Float to the ACECHC project, a major assumption had to be made during the start of the study and that was to develop an As-Planned Schedule. The other aspect to be considered is that the concept was applied on an ongoing project. The actual implementation of this concept should begin during contract preparation, prior to the project's starting date (Prateapusanond 2003). Hence, it would be a good idea to simultaneously apply the current definition of total float as endorsed by the courts along with the new concept of Pre-Allocation of Total Float and compare the results. This would highlight the advantages and disadvantages of this new concept over the existing one.

If the required computer support and automated bookkeeping procedures are available, the advantages of implementing this concept are significant. Some of the owners and contractors in the industry who were asked for their opinion on this new concept were concerned only about its cost of implementation and ease. Both parties felt that pre-allocating the float at the start of the project and then monitoring this float carefully would solve most of the problems, which would have otherwise resulted in disputes. This concept will not eliminate all the claims and disputes in the industry but will provide a strong ground to judge these disputes and find amicable solutions. It can also serve as a decision making tool for most parties and in the future may be widely used by courts as well.

Overall, the areas of future research are summarized as:

- Developing criteria's for the various scheduling problems occurring during any construction project, which are not addressed to, by the concept of Pre-Allocation of Total Float.
- Solutions must be developed to resolve the issue of fractional total floats
- Develop computer programs or enhance existing scheduling packages to filter out the relevant data from project schedules to keep track of the project schedules and the ATF values closely.
- Develop criteria to determine the amount of float that must be allocated to each party.
- Applying the concept in conjunction with the current concept of float ownership on a project, right from the contract preparation stage

References

- Bubshait, Abdulaziz. A., and Cunningham, Michael. J., (1998) “Determining Schedule Impact: Working Practice” *Practice Periodical on Structural Design and Construction*, Vol. 3, No. 4, November, pp. 176-179
- Capuano, Don Jr. (1995). “Required CPM (Critical Path Method) for Lawsuits; Around the Corner?”,
<http://www/wings.buffalo.edu/Complaw/CompLawPapers/capuano.html>
- De La Garza, Jesus, Vorster, Michael C., and Parvin, Cordell M. (1991). “Total Float Traded as Commodity”, *Journal of Construction Engineering and Management*, 117 (4), December, 716-727.
- Elazouni, A. M., and Metwally, F. G., (2000) “D-SUB: Decision Support System for Subcontracting Construction Works” *Journal of Construction Engineering and Management*, Vol. 126, No. 3, May/June 2000, pp. 191-200
- Finke, Michael. R., (1998) “Better Way to Estimate and Mitigate Disruption” *Journal of Construction Engineering and Management*, Vol. 124, No. 6, November/December, pp. 490-497
- Householder, Jerry L. and Rutland, Hulan E. (1990). “Who Owns Floats”, *Journal of Construction Engineering and Management*, 116 (1), March, 130-133.
- Karumanasseri, G., and AbouRizk, S., (2002) “Decision Support System for Scheduling Steel Fabrication Projects” *Journal of Construction Engineering and Management*, Vol. 128, No. 5, September/October 2002, pp. 392-399

- Kyunghwan, Kim., and De La Garza, Jesus., (2003) “Phantom Float” *Journal of Construction Engineering and Management*, Vol 129, No. 5, September/October 2003, pp. 507-517
- Kraiem, Zaki I. and Diekmann, James E., (1987) “Concurrent delays in Construction Projects” *Journal of Construction Engineering and Management*, Vol 113, No. 4, December 1987, pp. 591-602
- Mellin, J. W., and Whiteaker, B., (1981). “Fencing a Bar Chart” *J. of Construction Division*, ASCE, 107, 497-507.
- Mulholland, B., and Christian, J., (1999). “Risk Assessment in Construction Schedules” *Journal of Construction Engineering and Management*, Vol. 125, No. 1, January/February 1999, pp. 8-15
- Ponce de Leon, Gui. (1986). “Float Ownership Specs Treatment”, *Cost Engineering*, 28 (10), October, 12-15.
- Prateapusanond, A. (2003), “A Comprehensive Practice of Pre-Allocation of Total Float in the Application of A CPM-Based Construction Contract”, *PhD Dissertation*, Construction Engineering and Management, Department of Civil Engineering, Virginia Polytechnic and State University, Blacksburg, Virginia, USA
- Schumacher, Lee. (1996). “An Integrated and Proactive Approach for Avoiding Delay Claims on Major Capital Projects”, *Cost Engineering*, 38 (6), 37-39
- Wickwire, Jon M., Driscoll, Thomas J., and Hurlbut, Stephen B. (1991). “Construction Scheduling: Preparation, Liability, and Claims”, Wiley Law Publication, New York, NY.

- Zouein, P. P., and Tommelein, I. D., (2001). “Improvement Algorithm for Limited Space Scheduling” *Journal of Construction Engineering and Management*, Vol. 127, No. 2, March/April 2001, pp. 116-124

Appendix A

The As-Planned Schedule

Table A-1: the Start-Finish database & the ATF database for the As-Planned Schedule

ID	Description	Start-Finish Database		ATF Database		
		Start	Finish	TF	Owner	Contractor
1	Notice to Proceed	4/15/2003	4/15/2003	0	0	0
2	Submittals	4/15/2003	5/29/2003	75	37.5	37.5
3	02630 Storm Drainage Submittal	4/15/2003	4/24/2003	273	136.5	136.5
4	02630 Storm Drainage Delivery	5/9/2003	5/9/2003	273	136.5	136.5
5	03300 Reinforcing Steel Submittal Conf	4/15/2003	4/15/2003	87	43.5	43.5
6	03300 Reinforcing Steel Delivery Conf	4/30/2003	4/30/2003	87	43.5	43.5
7	03300 Reinforcing Steel Submittal Alumni	4/15/2003	4/15/2003	200	100	100
8	03300 Reinforcing Steel Delivery Alumni	4/30/2003	4/30/2003	200	100	100
9	03415 Precast Slab Submittal	4/15/2003	4/15/2003	103	51.5	51.5
10	03415 Precast Slab Delivery	4/30/2003	4/30/2003	103	51.5	51.5
11	03450 Arch Precast Hotel Submittal	4/15/2003	4/15/2003	202	101	101
12	03450 Arch Precast Hotel Delivery	4/30/2003	4/30/2003	202	101	101
13	04200 Masonry Submittal	4/15/2003	4/17/2003	75	37.5	37.5
14	04200 Masonry Submittal Delivery	5/2/2003	5/2/2003	75	37.5	37.5
15	05120 Structural Steel Conference Submittal	4/15/2003	4/15/2003	130	65	65
16	05120 Structural Steel Conference Delivery	4/30/2003	4/30/2003	130	65	65
17	05120 Structural Steel Alumni Submittal	4/15/2003	4/15/2003	225	112.5	112.5
18	05120 Structural Steel Alumni Delivery	4/30/2003	4/30/2003	225	112.5	112.5
19	05210/05300 Joist/Deck Submittal	4/15/2003	4/23/2003	144	72	72
20	05120/05300 Joist/Deck Delivery	5/8/2003	5/8/2003	144	72	72
21	05500 Metal Fabrication Hotel Submittal	4/15/2003	5/1/2003	97	48.5	48.5
22	05500 Metal Fabrication Hotel Delivery	5/16/2003	5/16/2003	97	48.5	48.5
23	06400 Arch Woodwork Submittal	4/15/2003	4/15/2003	430	215	215
24	06400 Arch Woodwork Delivery	4/30/2003	4/30/2003	430	215	215
25	07115 Waterproofing Submittal	4/15/2003	4/22/2003	81	40.5	40.5
26	07115 Waterproofing Delivery	5/7/2003	5/7/2003	81	40.5	40.5
27	07530/07600 Roofing Submittal	4/15/2003	4/15/2003	200	100	100
28	07530/07600 Roofing Delivery	4/30/2003	4/30/2003	200	100	100
29	08110 Door & Frame Submittal Hotel	4/15/2003	4/17/2003	96	48	48
30	08110 Door & Frame Delivery Hotel	5/2/2003	5/2/2003	96	48	48
31	08110 Door & Frame Submittal Conf	4/15/2003	4/22/2003	180	90	90
32	08110 Door & Frame Delivery Conf	5/7/2003	5/7/2003	180	90	90
33	08110 Door & Frame Submittal Alumni	4/15/2003	4/22/2003	272	136	136
34	08110 Door & Frame Delivery Alumni	5/7/2003	5/7/2003	272	136	136
35	08410 Storefront Submittal	4/15/2003	4/15/2003	459	229.5	229.5
36	08410 Storefront Delivery	4/30/2003	4/30/2003	459	229.5	229.5
37	08520 Window Submittal	4/15/2003	4/15/2003	295	147.5	147.5
38	08520 Window Delivery	4/30/2003	4/30/2003	295	147.5	147.5
39	08710 Finish Hardware Submittal	4/15/2003	4/22/2003	411	205.5	205.5
40	08710 Finish Hardware Delivery	5/21/2003	5/21/2003	411	205.5	205.5
41	09100/09250 Stud & Drywall Submittal	4/15/2003	4/15/2003	292	146	146
42	09100/09250 Stud & Drywall Delivery	4/30/2003	4/30/2003	292	146	146
43	09680 Carpet Submittal	4/15/2003	4/15/2003	369	184.5	184.5
44	09680 Carpet Delivery	4/30/2003	4/30/2003	369	184.5	184.5
45	09900 Paint Submittal	4/15/2003	4/15/2003	450	225	225
46	09900 Paint Delivery	4/30/2003	4/30/2003	450	225	225
47	10650 Operable Partition Submittal	4/15/2003	4/15/2003	243	121.5	121.5
48	10650 Operable Partition Delivery	4/30/2003	4/30/2003	243	121.5	121.5
49	11400 Food Service Rough In Submittal	4/15/2003	4/15/2003	144	72	72
50	11400 Food Service Submittal	4/15/2003	4/15/2003	426	213	213

Table A-1: Continued [pg. 2 of 20]

ID	Description	Start-Finish Database			ATF Database	
		Start	Finish	TF	Owner	Contractor
51	11400 Food Service Delivery	4/30/2003	4/30/2003	426	213	213
52	14240 Elevator Submittal	4/15/2003	4/15/2003	416	208	208
53	14240 Elevator Delivery	4/30/2003	4/30/2003	416	208	208
54	15500 Fire Protection Submittal	4/15/2003	4/15/2003	298	149	149
55	15500 Fire Protection Delivery	5/29/2003	5/29/2003	298	149	149
56	15556 Boiler Submittal	4/15/2003	4/15/2003	414	207	207
57	15556 Boiler Delivery	4/30/2003	4/30/2003	414	207	207
58	15685 Chiller Submittal	4/15/2003	4/25/2003	406	203	203
59	15685 Chiller Delivery	5/12/2003	5/12/2003	406	203	203
60	15711 Cooling Tower Submittal	4/15/2003	4/15/2003	416	208	208
61	15711 Cooling Tower Delivery	4/30/2003	4/30/2003	416	208	208
62	15830 Hydronic Terminal Units Submittal	4/15/2003	4/15/2003	288	144	144
63	15830 Hydronic Terminal Units Delivery	4/30/2003	4/30/2003	288	144	144
64	15856 Rooftop AHU Submittal	4/15/2003	4/15/2003	141	70.5	70.5
65	15886 Rooftop AHU Delivery	4/30/2003	4/30/2003	141	70.5	70.5
66	16425 Switchboard Submittal	4/15/2003	4/15/2003	431	215.5	215.5
67	16425 Switchboard Delivery	4/30/2003	4/30/2003	431	215.5	215.5
68	16460 Transformers Submittal	4/15/2003	4/15/2003	434	217	217
69	16460 Transformers Delivery	4/30/2003	4/30/2003	434	217	217
70	16470 Panelboards Submittal	4/15/2003	4/15/2003	302	151	151
71	16470 Panelboards Delivery	4/30/2003	4/30/2003	302	151	151
72	16511 Luminaires Submittal	4/15/2003	4/15/2003	404	202	202
73	16511 Luminaires Delivery	4/30/2003	4/30/2003	404	202	202
74	16722 Fire Alarm System Submittal	4/15/2003	4/15/2003	424	212	212
75	16722 Fire Alarm Delivery	4/30/2003	4/30/2003	424	212	212
76	17100 Auto Temp Controls Submittal	4/15/2003	4/15/2003	355	177.5	177.5
77	17100 Auto Temperature Controls Delivery	4/30/2003	4/30/2003	355	177.5	177.5
78	MOBILIZATION	4/16/2003	5/19/2003	0	0	0
79	Engineer Layout - Limits of Construction	4/16/2003	4/16/2003	0	0	0
80	Site Fence	4/17/2003	5/2/2003	0	0	0
81	Barricade at Walk Paths - Prices Fork & West Campus	4/17/2003	4/17/2003	22	11	11
82	Install Job Entrances	4/18/2003	4/21/2003	22	11	11
83	Grade & Stone Pad for Site Offices	5/5/2003	5/19/2003	287	143.5	143.5
84	Mobilize Trailers	5/19/2003	5/19/2003	287	143.5	143.5
85	SITE DEMOLITION	4/17/2003	5/14/2003	8	4	4
86	Irrigation System	4/17/2003	4/18/2003	26	13	13
87	Trees / Shrubs	5/5/2003	5/14/2003	8	4	4
88	Signs	4/22/2003	4/24/2003	22	11	11
89	STORM MANAGEMENT / EROSION CONTROL	5/5/2003	7/29/2003	0	0	0
90	Silt Fence & Diversion Dikes	5/5/2003	5/9/2003	0	0	0
91	Temp Entrance at Road H	5/12/2003	5/27/2003	0	0	0
92	Sediment Trap No. 1 & 2 - Pond	5/27/2003	5/27/2003	0	0	0
93	Install Temporary Sediment Basin - No. 1	5/28/2003	6/9/2003	0	0	0
94	Install Storm Line At TSB #1	6/10/2003	6/12/2003	241	120.5	120.5
95	Install Temporary Sediment Basin - No. 2	6/13/2003	6/17/2003	241	120.5	120.5
96	Construct Sediment Basin - #2	6/18/2003	7/16/2003	241	120.5	120.5
97	Install Storm Line at TSB #2	7/17/2003	7/23/2003	241	120.5	120.5
98	Topsoil & Seed Sediment Basin - 2	7/24/2003	7/29/2003	241	120.5	120.5
99	Excavate & Pour Footings at Retaining Wall	6/18/2003	6/20/2003	242	121	121
100	Form & Pour Retaining Wall	6/23/2003	6/25/2003	242	121	121

Table A-1: Continued [pg. 3 of 20]

ID	Description	Start-Finish Database		ATF Database		
		Start	Finish	TF	Owner	Contractor
101	Lay Hokie Stone on Retaining Wall	6/26/2003	7/17/2003	242	121	121
102	Strip Topsoil & Stockpile	6/10/2003	6/25/2003	0	0	0
103	Rough Grade for Road H	7/18/2003	7/28/2003	242	121	121
104	TEMPORARY ROADS	6/10/2003	7/31/2003	273	136.5	136.5
105	Demo for Turning Lane - West Campus	6/10/2003	6/10/2003	273	136.5	136.5
106	Grading for Turning Lane - West Campus	6/11/2003	6/11/2003	273	136.5	136.5
107	Curb Inlet & Pipe Turning Lane -West Campus	6/12/2003	6/13/2003	273	136.5	136.5
108	Curb & Gutter Turning Lane - West Campus	6/16/2003	6/18/2003	273	136.5	136.5
109	Stone Base at Turning Lane - West Campus	6/19/2003	6/19/2003	273	136.5	136.5
110	Asphalt Base at Turning Lane - West Campus	6/20/2003	6/20/2003	273	136.5	136.5
111	Pave Asphalt Walk at West Campus	6/23/2003	6/23/2003	273	136.5	136.5
112	Install Guardrail	7/29/2003	7/31/2003	276	138	138
113	GRADE BUILDING PADS	6/13/2003	7/9/2003	0	0	0
114	Grade Hotel Area	6/13/2003	6/13/2003	0	0	0
115	Grade Conference Center Area	6/16/2003	6/27/2003	0	0	0
116	Grade Alumni Center Area	6/30/2003	7/9/2003	0	0	0
117	GRADE SITE	7/10/2003	8/15/2003	235	117.5	117.5
118	North Hotel Side of Building	7/10/2003	7/30/2003	235	117.5	117.5
119	East Conference Front Side of Building	7/31/2003	8/6/2003	235	117.5	117.5
120	South Alumni Side of Building	8/7/2003	8/15/2003	235	117.5	117.5
121	INSTALL SITE UTILITIES	8/7/2003	2/2/2004	242	121	121
122	Install Underground Electrical Service (NIC)	8/7/2003	8/13/2003	373	186.5	186.5
123	Install Storm Line 02 to 06	8/18/2003	8/29/2003	235	117.5	117.5
124	Install Storm Line 06 to 11	9/2/2003	9/11/2003	235	117.5	117.5
125	Install Storm Line 11 to 27	9/12/2003	10/9/2003	235	117.5	117.5
126	Complete Storm Lines at North Parking	10/10/2003	11/6/2003	235	117.5	117.5
127	Install Sanitary Sewer	11/7/2003	11/20/2003	235	117.5	117.5
128	Start Water Line B (under Road B)	9/12/2003	9/18/2003	266	133	133
129	Install Water Line A (Hotel North)	10/10/2003	10/22/2003	251	125.5	125.5
130	Complete Water Line B(Alumni)	10/23/2003	10/28/2003	251	125.5	125.5
131	Install Water Line C (Hotel South)	10/29/2003	11/4/2003	251	125.5	125.5
132	Secondary Storm Piping Connect to Hotel	11/21/2003	12/8/2003	235	117.5	117.5
133	Secondary Storm Piping Connect to Conf.	12/9/2003	12/16/2003	235	117.5	117.5
134	Secondary Storm Piping Connect to Alumni	12/17/2003	12/18/2003	235	117.5	117.5
135	Install Fire Hydrant Along Prices Fork	11/5/2003	11/6/2003	381	190.5	190.5
136	Pour Light Pole Bases	12/19/2003	1/7/2004	235	117.5	117.5
137	Start Site Lighting UG, C Road&North Parking	1/8/2004	1/15/2004	235	117.5	117.5
138	Complete UG Site Lighting, B Road	1/16/2004	1/21/2004	235	117.5	117.5
139	Install UG Site Lighting, East of Conference	1/22/2004	2/2/2004	235	117.5	117.5
140	PAVING START NORTH PARKING AREA	11/7/2003	8/5/2004	121	60.5	60.5
141	Fine Grade North Parking & at B, C Road	11/7/2003	11/12/2003	272	136	136
142	Owner Install UG Control Access - Road A/B	11/13/2003	11/17/2003	272	136	136
143	Install Curb&Gutter at B,C Road & West 5 Lots	11/18/2003	12/3/2003	272	136	136
144	Install Curb&Gutter at B,C Road & East 5 Lots	12/4/2003	12/17/2003	272	136	136
145	Base Stone North B,C Road & 10 Parking Lot	12/18/2003	12/31/2003	272	136	136
146	Install Fire Road at Hotel	7/27/2004	8/5/2004	72	36	36
147	PAVING START EAST/SOUTH PARKING AREA	2/3/2004	3/4/2004	235	117.5	117.5
148	Stone and Base Pave H Road	2/3/2004	2/12/2004	235	117.5	117.5
149	Fine Grade East Parking from D to G parking	2/13/2004	2/17/2004	235	117.5	117.5
150	Curb&Gutter East Parking from D to G parking	2/18/2004	2/24/2004	235	117.5	117.5

Table A-1: Continued [pg. 4 of 20]

ID	Description	Start-Finish Database			ATF Database	
		Start	Finish	TF	Owner	Contractor
151	Base Stone East Parking from D to G parking	2/25/2004	3/2/2004	235	117.5	117.5
152	Base Pave Road from D to G	3/3/2004	3/4/2004	235	117.5	117.5
153	SERVICE YARD WORK	8/12/2004	10/14/2004	124	62	62
154	Install Footings Service Court Wall	8/12/2004	8/18/2004	124	62	62
155	Forn & Pour Service Court Wall	8/19/2004	9/1/2004	124	62	62
156	CMU Service Court Wall	9/2/2004	9/16/2004	124	62	62
157	Install Grease Traps & Lines	9/17/2004	9/21/2004	124	62	62
158	Install Removable Bollards in Service Road	9/22/2004	9/23/2004	124	62	62
159	Form & Pour Service Court Equipment Pads	9/24/2004	9/30/2004	124	62	62
160	Prep & Pour Concrete Service Yard Slab	10/1/2004	10/12/2004	124	62	62
161	Set Transformer	10/13/2004	10/14/2004	124	62	62
162	COMPLETE BASE PAVING	6/16/2004	8/27/2004	57	28.5	28.5
163	Fine Grade Road A from Prices Fork to E	6/16/2004	6/23/2004	57	28.5	28.5
164	Curb & Gutter Road A from Prices Fork to E	6/24/2004	7/9/2004	57	28.5	28.5
165	Base Stone Road A from Prices Fork to E	7/12/2004	7/19/2004	57	28.5	28.5
166	Base Pave Road A from Prices Fork to E	7/20/2004	7/21/2004	57	28.5	28.5
167	Fine Grade E Loop and Road D	7/22/2004	7/28/2004	57	28.5	28.5
168	C & G Road E Loop and Road D	7/29/2004	8/11/2004	57	28.5	28.5
169	Base Stone E Loop and Road D	8/12/2004	8/20/2004	57	28.5	28.5
170	Base Pave E Loop and Road D	8/23/2004	8/24/2004	57	28.5	28.5
171	Install Road H Stone Parking Spaces	8/25/2004	8/27/2004	100	50	50
172	PRICES FORK ENTRANCE	7/22/2004	8/19/2004	188	94	94
173	Demolition	7/22/2004	7/26/2004	188	94	94
174	Install New Traffic Signals	7/27/2004	7/30/2004	188	94	94
175	Install Curb & Gutter	8/2/2004	8/6/2004	188	94	94
176	Install New Paving	8/9/2004	8/11/2004	188	94	94
177	Install New Sidewalk	8/12/2004	8/17/2004	188	94	94
178	Fine Grade & Seed	8/18/2004	8/19/2004	188	94	94
179	HOTEL CANOPY & ENTRANCE	8/25/2004	11/3/2004	135	67.5	67.5
180	Dig & Pour Canopy Foundations	8/25/2004	8/30/2004	135	67.5	67.5
181	Erect Canopy Structure	8/31/2004	9/10/2004	135	67.5	67.5
182	Complete Canopy Column Veneer	9/13/2004	9/22/2004	135	67.5	67.5
183	Install Hotel Entrance Roofing	9/23/2004	9/30/2004	135	67.5	67.5
184	Pour Concrete Strips at Hotel Entrance	10/1/2004	10/7/2004	135	67.5	67.5
185	Install Paver Base at Hotel Entrance	10/8/2004	10/14/2004	135	67.5	67.5
186	Install Hotel Entrance Bollards	10/15/2004	10/18/2004	135	67.5	67.5
187	Install Hotel Entrance Pavers	10/19/2004	11/1/2004	135	67.5	67.5
188	Install Site Furniture at Hotel Entrance	11/2/2004	11/3/2004	135	67.5	67.5
189	ALUMNI FOUNTAIN	11/23/2004	3/1/2005	40	20	20
190	Install UG Plumbing to Fountain	11/23/2004	12/1/2004	40	20	20
191	Install UG Electrical to Fountain	12/2/2004	12/3/2004	40	20	20
192	Install Fountain Concrete	12/6/2004	12/17/2004	40	20	20
193	Install Fountain Hokie Stone	12/20/2004	1/4/2005	40	20	20
194	Install Pumps & Equipment	1/5/2005	1/11/2005	40	20	20
195	Install Base Under Pavers	1/12/2005	1/25/2005	40	20	20
196	Install Sidewalk Pavers	1/26/2005	2/8/2005	40	20	20
197	Install Fountain Pavers	2/9/2005	3/1/2005	40	20	20
198	ALUMNI TERRACE	1/5/2005	3/22/2005	40	20	20
199	Construct Retaining Wall	1/5/2005	1/11/2005	65	32.5	32.5
200	Install Base Under Terrace Pavers	1/26/2005	2/8/2005	55	27.5	27.5

Table A-1: Continued [pg. 5 of 20]

ID	Description	Start-Finish Database			ATF Database	
		Start	Finish	TF	Owner	Contractor
201	Install Terrace Pavers	3/2/2005	3/22/2005	40	20	20
202	COMPLETE SITEWORK	8/25/2004	2/25/2005	57	28.5	28.5
203	Install Flag Pole Bases at Road A / E Loop	8/25/2004	8/26/2004	57	28.5	28.5
204	Spread Topsoil Next To Building	8/27/2004	9/2/2004	57	28.5	28.5
205	Install Sidewalk North Parking to D	9/3/2004	9/24/2004	57	28.5	28.5
206	Install West Hotel Pavers	9/27/2004	9/30/2004	57	28.5	28.5
207	Install Sidewalk at Hotel Front	10/1/2004	10/14/2004	57	28.5	28.5
208	Install Mulch Walk	10/15/2004	10/18/2004	57	28.5	28.5
209	Install Sidewalk Between Conf & D Road	10/19/2004	11/1/2004	57	28.5	28.5
210	Install Alumni Entrance Sidewalk from WCD	11/2/2004	11/8/2004	57	28.5	28.5
211	Install Sidewalk at H road	11/9/2004	11/15/2004	57	28.5	28.5
212	Install Sidewalk at Conference West Side	11/16/2004	11/29/2004	57	28.5	28.5
213	Install Sidewalk Around Alumni	11/30/2004	12/13/2004	57	28.5	28.5
214	Install Road H Pavilions	8/30/2004	9/27/2004	111	55.5	55.5
215	Spread Topsoil North Parking Area	10/15/2004	10/28/2004	77	38.5	38.5
216	Spread Topsoil East Side Building	10/29/2004	11/4/2004	77	38.5	38.5
217	Spread Topsoil West Side of Building	12/7/2004	12/14/2004	57	28.5	28.5
218	Spread Topsoil South of Building	12/15/2004	12/22/2004	57	28.5	28.5
219	Install Site Light Poles & Fixtures	12/16/2004	12/22/2004	57	28.5	28.5
220	Seed at A from Prices Fork to Loop of Road E	12/23/2004	1/7/2005	57	28.5	28.5
221	Seed at E Loop & Island to Road D	1/10/2005	1/14/2005	57	28.5	28.5
222	Seed East of Conference	1/17/2005	1/20/2005	57	28.5	28.5
223	Seed West of Conference	1/21/2005	1/28/2005	57	28.5	28.5
224	Seed South of Alumni	1/31/2005	2/4/2005	57	28.5	28.5
225	Install Landscaping at Sediment Basin - 2	12/23/2004	12/29/2004	78	39	39
226	Install Landscaping	12/23/2004	1/21/2005	76	38	38
227	Install Site Signage	1/24/2005	1/27/2005	76	38	38
228	Remove Erosion Control Devices	2/24/2005	2/25/2005	57	28.5	28.5
229	FINAL ASPHALT PAVING	1/17/2005	2/7/2005	71	35.5	35.5
230	Surface Asphalt Road A & E Loop	1/17/2005	1/18/2005	71	35.5	35.5
231	Surface Asphalt North Parking, Road B to D, & C	1/19/2005	1/21/2005	71	35.5	35.5
232	Surface Asphalt Road D	1/24/2005	1/25/2005	71	35.5	35.5
233	Surface Asphalt Road B, F, G	1/26/2005	1/28/2005	71	35.5	35.5
234	Surface Asphalt Road H	1/31/2005	1/31/2005	71	35.5	35.5
235	Install Stripping	2/1/2005	2/7/2005	71	35.5	35.5
236	BUILDING FOUNDATION - WEST HOTEL	7/8/2003	10/30/2003	0	0	0
237	Establish Major Axis Lines- WH	7/10/2003	7/10/2003	0	0	0
238	Layout Footings - WH	7/8/2003	8/6/2003	0	0	0
239	Excavate Footings - WH	8/1/2003	8/26/2003	0	0	0
240	Layout / Drill Elevator Jack Hole - WH	8/7/2003	9/2/2003	8	4	4
241	Form and Place Footings - WH	8/14/2003	9/8/2003	0	0	0
242	Form & Place Concrete Wall - WH	8/26/2003	9/5/2003	0	0	0
243	Waterproof Walls - WH	9/8/2003	9/9/2003	0	0	0
244	CMU to Finish Floor - WH	9/3/2003	9/10/2003	1	0.5	0.5
245	Backfill & Compact - WH	9/10/2003	9/16/2003	0	0	0
246	U.G. Plumbing - WH	9/11/2003	9/26/2003	0	0	0
247	Slab Stone Base - WH	9/25/2003	9/30/2003	0	0	0
248	U.G. Electrical - WH	9/30/2003	10/3/2003	0	0	0
249	Termite Treatment - WH	10/6/2003	10/6/2003	0	0	0
250	Prep and Place Slab-on-Grade - WH	10/7/2003	10/8/2003	0	0	0

Table A-1: Continued [pg. 6 of 20]

ID	Description	Start-Finish Database			ATF Database	
		Start	Finish	TF	Owner	Contractor
251	Set Tube Steel / Misc at Windows - WH	10/9/2003	10/20/2003	0	0	0
252	1st FI Set Hollow Metal Frames - WH	10/9/2003	10/14/2003	1	0.5	0.5
253	CMU to 2nd Floor - WH	10/14/2003	10/30/2003	0	0	0
254	BUILDING FOUNDATION - EAST HOTEL	7/11/2003	11/12/2003	6	3	3
255	Establish Major Axis Lines - EH	7/11/2003	7/14/2003	37	18.5	18.5
256	Layout Footings - EH	8/14/2003	8/20/2003	15	7.5	7.5
257	Excavate Footings - EH	8/15/2003	8/26/2003	19	9.5	9.5
258	Layout / Drill Elevator Jack Holes - EH	9/3/2003	9/8/2003	8	4	4
259	Form and Place Footings - EH	8/15/2003	8/26/2003	19	9.5	9.5
260	Form and Place Concrete Walls - EH	9/9/2003	9/22/2003	8	4	4
261	Waterproof Walls - EH	9/23/2003	9/24/2003	8	4	4
262	CMU to Finish Floor - EH	8/27/2003	9/2/2003	24	12	12
263	Backfill & Compact - EH	9/25/2003	9/29/2003	8	4	4
264	U.G. Plumbing - EH	9/29/2003	10/20/2003	6	3	3
265	Slab Stone Base - EH	10/17/2003	10/20/2003	6	3	3
266	U.G. Electrical - EH	10/21/2003	10/23/2003	6	3	3
267	Termite Treatment - EH	10/24/2003	10/24/2003	6	3	3
268	Prep and Place Slab-on-Grade - EH	10/27/2003	10/27/2003	6	3	3
269	Set Tube Steel / Misc at Windows - EH	10/28/2003	11/3/2003	9	4.5	4.5
270	1st FI Set Hollow Metal Frames - EH	10/28/2003	10/30/2003	6	3	3
271	CMU to 2nd Floor - EH	10/31/2003	11/12/2003	6	3	3
272	STRUCTURE - WEST HOTEL - 2nd FLOOR	10/31/2003	12/2/2003	0	0	0
273	2nd FI Set / Grout Concrete Planks - WH	10/31/2003	11/6/2003	0	0	0
274	2nd FI Set Hollow Metal Frames - WH	11/7/2003	11/12/2003	0	0	0
275	2nd FI Lay CMU to 3rd Floor - WH	11/10/2003	12/2/2003	0	0	0
276	2nd FI Set Tube & Metals at Windows - WH	11/14/2003	11/25/2003	3	1.5	1.5
277	2nd FI Set Lintels - WH	11/20/2003	11/25/2003	3	1.5	1.5
278	STRUCTURE - EAST HOTEL - 2nd FLOOR	11/13/2003	12/8/2003	6	3	3
279	2nd FI Set / Grout Concrete Planks - EH	11/13/2003	11/17/2003	6	3	3
280	2nd FI Set Hollow Metal Frames - EH	11/18/2003	11/20/2003	6	3	3
281	2nd FI Lay CMU to 3rd Floor - EH	11/21/2003	12/8/2003	6	3	3
282	2nd FI Set Tube & Metals at Windows - EH	11/24/2003	12/3/2003	9	4.5	4.5
283	2nd FI Set Lintels - EH	12/1/2003	12/3/2003	9	4.5	4.5
284	STRUCTURE - WEST HOTEL - 3rd FLOOR	12/3/2003	1/7/2004	0	0	0
285	3rd FI Set / Grout Concrete Planks - WH	12/3/2003	12/9/2003	0	0	0
286	3rd FI Set Hollow Metal Frames - WH	12/10/2003	12/15/2003	0	0	0
287	3rd FI Lay CMU to 4th Floor - WH	12/11/2003	1/7/2004	0	0	0
288	3rd FI Set Tube & Metals at Windows - WH	12/17/2003	12/31/2003	3	1.5	1.5
289	3rd FI Set Lintels - WH	12/23/2003	12/31/2003	3	1.5	1.5
290	STRUCTURE - EAST HOTEL - 3rd FLOOR	12/10/2003	1/7/2004	5	2.5	2.5
291	3rd FI Set / Grout Concrete Planks - EH	12/10/2003	12/12/2003	5	2.5	2.5
292	3rd FI Set Hollow Metal Frames - EH	12/15/2003	12/17/2003	5	2.5	2.5
293	3rd FI Lay CMU to 4th Floor - EH	12/18/2003	1/7/2004	5	2.5	2.5
294	3rd FI Set Tube & Metals at Windows - EH	12/19/2003	12/31/2003	8	4	4
295	3rd FI Set Lintels - EH	12/29/2003	12/31/2003	8	4	4
296	STRUCTURE - WEST HOTEL - 4th FLOOR	1/8/2004	2/5/2004	0	0	0
297	4th FI Set / Grout Concrete Planks - WH	1/8/2004	1/14/2004	0	0	0
298	4th FI Set Hollow Metal Frames - WH	1/15/2004	1/20/2004	3	1.5	1.5
299	4th FI Lay CMU to Roof - WH	1/16/2004	2/5/2004	3	1.5	1.5
300	4th FI Set Tube & Metals at Windows - WH	1/22/2004	2/2/2004	3	1.5	1.5

Table A-1: Continued [pg. 7 of 20]

ID	Description	Start-Finish Database			ATF Database	
		Start	Finish	TF	Owner	Contractor
301	4th FI Set Lintels - WH	1/28/2004	2/2/2004	3	1.5	1.5
302	STRUCTURE - EAST HOTEL - 4th FLOOR	1/15/2004	2/5/2004	0	0	0
303	4th FI Set / Grout Concrete Planks - EH	1/15/2004	1/19/2004	0	0	0
304	4th FI Set Hollow Metal Frames - EH	1/20/2004	1/22/2004	0	0	0
305	4th FI Lay CMU to Roof - EH	1/23/2004	2/5/2004	0	0	0
306	4th FI Set Tube & Metals at Windows - EH	1/26/2004	2/2/2004	3	1.5	1.5
307	4th FI Set Lintels - EH	1/29/2004	2/2/2004	3	1.5	1.5
308	Set Lobby Structural Steel/Deck - EH	1/20/2004	1/29/2004	25	12.5	12.5
309	STRUCTURE - HOTEL ROOF LEVEL	2/6/2004	3/11/2004	0	0	0
310	Roof Set / Grout Concrete Planks - H	2/6/2004	2/19/2004	0	0	0
311	Form & Place CRU #3 Slab on Roof - H	2/20/2004	2/24/2004	0	0	0
312	Set CRU #3 Mech Eqpt On Roof - H	2/25/2004	3/1/2004	0	0	0
313	Roof Build Parapet Walls - H	3/2/2004	3/11/2004	0	0	0
314	ROOFING - WEST HOTEL	3/12/2004	5/27/2004	0	0	0
315	Wood Blocking - WH	3/12/2004	3/17/2004	0	0	0
316	Coping / Misc. Metal Flashing - WH	3/18/2004	3/24/2004	0	0	0
317	Roof Insulation - WH	3/25/2004	3/31/2004	5	2.5	2.5
318	Roof Membrane - WH	4/1/2004	4/7/2004	5	2.5	2.5
319	Roof Scuppers - WH	4/8/2004	4/15/2004	250	125	125
320	Gutter and Downspout - WH	5/14/2004	5/27/2004	240	120	120
321	ROOFING - EAST HOTEL	1/30/2004	5/13/2004	25	12.5	12.5
322	Metal Roofing at Lobby - EH	1/30/2004	2/12/2004	25	12.5	12.5
323	Wood Blocking - EH	2/13/2004	2/18/2004	25	12.5	12.5
324	Coping / Misc. Metal Flashing - EH	3/25/2004	4/7/2004	0	0	0
325	Roof Insulation - EH	4/8/2004	4/14/2004	0	0	0
326	Roof Membrane - EH	4/15/2004	4/21/2004	0	0	0
327	Roof Scuppers - EH	4/22/2004	4/29/2004	240	120	120
328	Gutter and Downspout - EH	4/30/2004	5/13/2004	240	120	120
329	VENEER - HOTEL EAST	2/6/2004	7/26/2004	40	20	20
330	Precast Concrete at North Side - EH	2/6/2004	2/19/2004	40	20	20
331	Precast Concrete at South Side - EH	4/12/2004	4/21/2004	46	23	23
332	Dampproof & Set Hokie Stone - North - EH	2/12/2004	3/10/2004	40	20	20
333	Dampproof & Set Hokie Stone - South - EH	4/30/2004	5/27/2004	40	20	20
334	Install Windows North Side - EH	2/20/2004	3/9/2004	134	67	67
335	Install Windows South Side - EH	4/22/2004	5/7/2004	103	51.5	51.5
336	Precast Concrete Coping - EH	5/28/2004	6/11/2004	93	46.5	46.5
337	Set Exterior Door Frames - EH	5/28/2004	6/2/2004	100	50	50
338	Metal Stud Framing at Roof - EH	6/2/2004	6/22/2004	72	36	36
339	Gypsum Sheathing at Roof - EH	6/23/2004	6/30/2004	72	36	36
340	Metal Roofing - EH	7/1/2004	7/14/2004	72	36	36
341	Sealants - EH	7/15/2004	7/19/2004	72	36	36
342	Clean Veneer Stone - EH	7/20/2004	7/26/2004	72	36	36
343	VENEER - HOTEL WEST	2/20/2004	8/4/2004	45	22.5	22.5
344	Precast Concrete at North Side - WH	2/20/2004	3/16/2004	45	22.5	22.5
345	Precast Concrete at South Side - WH	3/17/2004	4/9/2004	46	23	23
346	Dampproof & Set Hokie Stone North - WH	3/11/2004	4/7/2004	40	20	20
347	Dampproof & Set Hokie Stone South - WH	4/8/2004	5/5/2004	40	20	20
348	Install Windows North Side - WH	3/17/2004	4/2/2004	256	128	128
349	Install Windows South Side - WH	4/12/2004	4/27/2004	251	125.5	125.5
350	Precast Concrete Coping - WH	5/6/2004	5/19/2004	235	117.5	117.5

Table A-1: Continued [pg. 8 of 20]

ID	Description	Start-Finish Database			ATF Database	
		Start	Finish	TF	Owner	Contractor
351	Set Exterior Door Frames - WH	5/6/2004	5/6/2004	244	122	122
352	Metal Stud Framing at Roof - WH	5/6/2004	5/21/2004	57	28.5	28.5
353	Gypsum Sheathing at Roof - WH	5/24/2004	6/1/2004	57	28.5	28.5
354	Metal Roofing - WH	6/2/2004	6/15/2004	57	28.5	28.5
355	Sealants - WH	7/20/2004	7/23/2004	195	97.5	97.5
356	Clean Veneer Stone - WH	7/27/2004	8/4/2004	194	97	97
357	INTERIOR FINISH HOTEL 4th Floor	4/22/2004	10/13/2004	0	0	0
358	Spray Fireproof - 4H	4/22/2004	4/27/2004	0	0	0
359	Gypsum Concrete - 4H	4/28/2004	5/3/2004	0	0	0
360	Install Stairs H1- 4H	4/22/2004	5/5/2004	113	56.5	56.5
361	Install Stairs H2 - 4H	5/6/2004	5/19/2004	113	56.5	56.5
362	Pour Stair Pans - 4H	5/20/2004	5/25/2004	113	56.5	56.5
363	Install HM Frames - 4H	5/4/2004	5/7/2004	0	0	0
364	Start Int Studs & Drywall 1 Side - 4H	5/6/2004	5/19/2004	0	0	0
365	Rough-In Plumbing - 4H	5/13/2004	6/10/2004	68	34	34
366	Rough-In HVAC Piping - 4H	5/13/2004	6/10/2004	68	34	34
367	Rough-In Ductwork - 4H	5/14/2004	6/3/2004	0	0	0
368	Rough-In Sprinkler - 4H	5/20/2004	6/7/2004	83	41.5	41.5
369	Rough-In Electrical - 4H	5/13/2004	6/8/2004	82	41	41
370	Insulate Plumbing Pipe - 4H	6/11/2004	6/28/2004	68	34	34
371	Insulate HVAC Pipe - 4H	6/11/2004	6/28/2004	68	34	34
372	Insulate Duct - 4H	6/4/2004	6/15/2004	77	38.5	38.5
373	Install Interior Wall Blocking - 4H	5/20/2004	5/25/2004	80	40	40
374	Install Tubs - 4H	5/26/2004	6/7/2004	80	40	40
375	Install Bath Door Frames & Complete Wall - 4H	6/8/2004	6/15/2004	80	40	40
376	Pull Electric Wire to Panels - 4H	6/9/2004	6/22/2004	176	88	88
377	Install Unit Drywall Ceilings - 4H	6/29/2004	7/13/2004	68	34	34
378	Complete & Finish Unit Drywall - 4H	7/7/2004	8/3/2004	72	36	36
379	Install Corridor Drywall Ceilings - 4H	7/14/2004	7/20/2004	68	34	34
380	Furr & Drywall Corridor - 4H	7/21/2004	8/5/2004	68	34	34
381	Paint Base & 1st Coat - 4H	8/2/2004	8/13/2004	68	34	34
382	Install Window Sills - 4H	8/4/2004	8/11/2004	72	36	36
383	Install Acoustical Tile Ceiling Grid - 4H	8/16/2004	8/18/2004	68	34	34
384	Install Control Rough-Ins - 4H	8/19/2004	8/25/2004	68	34	34
385	Install Ceramic Tile in Toilets - 4H	7/14/2004	7/27/2004	171	85.5	85.5
386	Install Lights - 4H	6/23/2004	6/30/2004	176	88	88
387	Finish Paint - 4H	8/12/2004	8/19/2004	148	74	74
388	Install Counter Tops - 4H	8/20/2004	8/27/2004	148	74	74
389	Set Plumbing Fixtures - 4H	8/30/2004	9/13/2004	148	74	74
390	Install Sprinkler Heads - 4H	8/19/2004	8/24/2004	69	34.5	34.5
391	Install Vinyl Wall Cover in Units - 4H	8/12/2004	8/23/2004	72	36	36
392	Install Toilet Accessories - 4H	9/14/2004	9/17/2004	148	74	74
393	Install Mech Diffusers - 4H	8/19/2004	8/24/2004	72	36	36
394	Trim Electric - 4H	8/20/2004	9/1/2004	159	79.5	79.5
395	Install Closet Shelves - 4H	8/24/2004	8/26/2004	163	81.5	81.5
396	Install Doors/Hardware - 4H	8/24/2004	9/7/2004	156	78	78
397	Install FEC - 4H	8/24/2004	8/24/2004	72	36	36
398	Install Ceiling Tile - 4H	8/26/2004	8/30/2004	68	34	34
399	Install Corridor VWC - 4H	8/31/2004	9/10/2004	68	34	34
400	Trim Controls - 4H	9/13/2004	9/14/2004	136	68	68

Table A-1: Continued [pg. 9 of 20]

ID	Description	Start-Finish Database			ATF Database	
		Start	Finish	TF	Owner	Contractor
401	Install Carpet - 4H	9/9/2004	9/22/2004	68	34	34
402	Install Wood Base - 4H	9/23/2004	10/6/2004	135	67.5	67.5
403	Install Rubber Base - 4H	9/23/2004	9/30/2004	139	69.5	69.5
404	Final Clean - 4H	10/7/2004	10/13/2004	135	67.5	67.5
405	INTERIOR FINISH HOTEL 3rd Floor	4/28/2004	10/27/2004	7	3.5	3.5
406	Spray Fireproof - 3H	4/28/2004	5/3/2004	7	3.5	3.5
407	Gypsum Concrete - 3H	5/4/2004	5/7/2004	7	3.5	3.5
408	Install HM Frames - 3H	5/10/2004	5/13/2004	7	3.5	3.5
409	Start Int Studs & Drywall 1 Side - 3H	5/14/2004	5/27/2004	7	3.5	3.5
410	Rough-In Plumbing - 3H	5/21/2004	6/11/2004	79	39.5	39.5
411	Rough-In HVAC Piping - 3H	5/21/2004	6/11/2004	79	39.5	39.5
412	Rough-In Ductwork - 3H	6/4/2004	6/17/2004	0	0	0
413	Rough-In Sprinkler - 3H	5/25/2004	6/10/2004	90	45	45
414	Rough-In Electrical - 3H	5/21/2004	6/11/2004	89	44.5	44.5
415	Insulate Plumbing Pipe - 3H	6/14/2004	6/25/2004	79	39.5	39.5
416	Insulate HVAC Pipe - 3H	6/14/2004	6/25/2004	79	39.5	39.5
417	Insulate Duct - 3H	6/18/2004	6/29/2004	77	38.5	38.5
418	Install Interior Wall Blocking - 3H	5/28/2004	6/3/2004	84	42	42
419	Install Tubs - 3H	6/4/2004	6/15/2004	84	42	42
420	Install Bath Door Frames & Complete Wall - 3H	6/16/2004	6/23/2004	84	42	42
421	Install Unit Drywall Ceilings - 3H	6/30/2004	7/14/2004	77	38.5	38.5
422	Pull Electric Wire to Panels - 3H	6/14/2004	6/25/2004	178	89	89
423	Complete & Finish Unit Drywall - 3H	7/8/2004	8/4/2004	81	40.5	40.5
424	Install Corridor Drywall Ceilings - 3H	7/15/2004	7/21/2004	77	38.5	38.5
425	Furr & Drywall Corridor - 3H	7/22/2004	8/6/2004	77	38.5	38.5
426	Paint Base & 1st Coat - 3H	8/3/2004	8/16/2004	77	38.5	38.5
427	Install Window Sills - 3H	8/5/2004	8/12/2004	81	40.5	40.5
428	Install Acoustical Tile Ceiling Grid - 3H	8/17/2004	8/19/2004	77	38.5	38.5
429	Install Control Rough-Ins - 3H	8/20/2004	8/26/2004	77	38.5	38.5
430	Install Ceramic Tile in Toilets - 3H	7/15/2004	7/28/2004	175	87.5	87.5
431	Install Lights - 3H	6/28/2004	7/7/2004	178	89	89
432	Finish Paint - 3H	8/13/2004	8/20/2004	152	76	76
433	Install Counter Tops - 3H	8/23/2004	8/30/2004	152	76	76
434	Set Plumbing Fixtures - 3H	8/31/2004	9/14/2004	152	76	76
435	Install Sprinkler Heads - 3H	8/20/2004	8/25/2004	78	39	39
436	Install Vinyl Wall Cover in Units - 3H	8/13/2004	8/24/2004	81	40.5	40.5
437	Install Toilet Accessories - 3H	9/15/2004	9/20/2004	152	76	76
438	Install Mech Diffusers - 3H	8/20/2004	8/25/2004	78	39	39
439	Trim Electric - 3H	8/23/2004	9/2/2004	163	81.5	81.5
440	Install Closet Shelves - 3H	8/25/2004	8/27/2004	167	83.5	83.5
441	Install Doors/Hardware - 3H	8/25/2004	9/8/2004	160	80	80
442	Install FEC - 3H	8/25/2004	8/25/2004	81	40.5	40.5
443	Install Ceiling Tile - 3H	8/27/2004	8/31/2004	77	38.5	38.5
444	Install Corridor VWC - 3H	9/1/2004	9/13/2004	77	38.5	38.5
445	Trim Controls - 3H	9/15/2004	9/16/2004	136	68	68
446	Install Carpet - 3H	9/23/2004	10/6/2004	68	34	34
447	Install Wood Base - 3H	10/7/2004	10/20/2004	130	65	65
448	Install Rubber Base - 3H	10/7/2004	10/14/2004	134	67	67
449	Final Clean - 3H	10/21/2004	10/27/2004	130	65	65

Table A-1: Continued [pg. 10 of 20]

ID	Description	Start-Finish Database			ATF Database	
		Start	Finish	TF	Owner	Contractor
450	INTERIOR FINISH HOTEL 2nd Floor	5/4/2004	11/10/2004	10	5	5
451	Spray Fireproof - 2H	5/4/2004	5/7/2004	10	5	5
452	Gypsum Concrete - 2H	5/10/2004	5/13/2004	10	5	5
453	Install HM Frames - 2H	5/14/2004	5/19/2004	10	5	5
454	Start Int Studs & Drywall 1 Side - 2H	5/20/2004	6/3/2004	10	5	5
455	Rough-In Plumbing - 2H	6/11/2004	7/1/2004	75	37.5	37.5
456	Rough-In HVAC Piping - 2H	6/11/2004	7/1/2004	75	37.5	37.5
457	Rough-In Ductwork - 2H	6/18/2004	7/1/2004	0	0	0
458	Rough-In Sprinkler - 2H	6/8/2004	6/23/2004	91	45.5	45.5
459	Rough-In Electrical - 2H	6/9/2004	6/29/2004	84	42	42
460	Insulate Plumbing Pipe - 2H	7/6/2004	7/19/2004	75	37.5	37.5
461	Insulate HVAC Pipe - 2H	7/6/2004	7/19/2004	75	37.5	37.5
462	Insulate Duct - 2H	7/6/2004	7/15/2004	77	38.5	38.5
463	Install Interior Wall Blocking - 2H	6/4/2004	6/9/2004	90	45	45
464	Install Tubs - 2H	6/10/2004	6/21/2004	90	45	45
465	Install Bath Door Frames & Complete Wall - 2H	6/22/2004	6/29/2004	90	45	45
466	Pull Electric Wire to Panels - 2H	6/30/2004	7/15/2004	171	85.5	85.5
467	Install Unit Drywall Ceilings - 2H	7/20/2004	7/30/2004	75	37.5	37.5
468	Complete & Finish Unit Drywall - 2H	7/26/2004	8/20/2004	79	39.5	39.5
469	Install Corridor Drywall Ceilings - 2H	8/2/2004	8/6/2004	75	37.5	37.5
470	Furr & Drywall Corridor - 2H	8/9/2004	8/24/2004	75	37.5	37.5
471	Paint Base & 1st Coat - 2H	8/19/2004	9/1/2004	75	37.5	37.5
472	Install Window Sills - 2H	8/23/2004	8/30/2004	79	39.5	39.5
473	Install Acoustical Tile Ceiling Grid - 2H	9/2/2004	9/7/2004	75	37.5	37.5
474	Install Control Rough-Ins - 2H	9/8/2004	9/14/2004	75	37.5	37.5
475	Install Ceramic Tile in Toilets - 2H	8/2/2004	8/13/2004	168	84	84
476	Install Lights - 2H	7/16/2004	7/23/2004	171	85.5	85.5
477	Finish Paint - 2H	8/31/2004	9/8/2004	145	72.5	72.5
478	Install Counter Tops - 2H	9/9/2004	9/16/2004	145	72.5	72.5
479	Set Plumbing Fixtures - 2H	9/17/2004	9/30/2004	145	72.5	72.5
480	Install Sprinkler Heads - 2H	9/8/2004	9/13/2004	76	38	38
481	Install Vinyl Wall Cover in Units - 2H	8/31/2004	9/10/2004	79	39.5	39.5
482	Install Toilet Accessories - 2H	10/1/2004	10/6/2004	145	72.5	72.5
483	Install Mech Diffusers - 2H	9/8/2004	9/13/2004	76	38	38
484	Trim Electric - 2H	9/9/2004	9/21/2004	156	78	78
485	Install Closet Shelves - 2H	9/13/2004	9/15/2004	160	80	80
486	Install Doors/Hardware - 2H	9/13/2004	9/24/2004	153	76.5	76.5
487	Install FEC - 2H	9/13/2004	9/13/2004	79	39.5	39.5
488	Install Ceiling Tile - 2H	9/15/2004	9/17/2004	75	37.5	37.5
489	Install Corridor VWC - 2H	9/20/2004	9/29/2004	75	37.5	37.5
490	Trim Controls - 2H	9/30/2004	10/4/2004	127	63.5	63.5
491	Install Carpet - 2H	10/7/2004	10/20/2004	68	34	34
492	Install Wood Base - 2H	10/21/2004	11/3/2004	125	62.5	62.5
493	Install Rubber Base - 2H	10/21/2004	10/28/2004	129	64.5	64.5
494	Final Clean - 2H	11/4/2004	11/10/2004	125	62.5	62.5
495	INTERIOR FINISH HOTEL 1st Floor	5/10/2004	11/30/2004	16	8	8
496	Spray Fireproof - 1H	5/10/2004	5/13/2004	16	8	8
497	Gypsum Concrete -1H	5/14/2004	5/19/2004	16	8	8
498	Install HM Frames - 1H	5/20/2004	5/25/2004	16	8	8
499	Start Int Studs & Drywall 1 Side - 1H	5/28/2004	6/11/2004	14	7	7
500	Rough-In Plumbing - 1H	6/14/2004	7/6/2004	86	43	43

Table A-1: Continued [pg. 11 of 20]

ID	Description	Start-Finish Database			ATF Database	
		Start	Finish	TF	Owner	Contractor
501	Rough-In HVAC Piping - 1H	6/14/2004	7/6/2004	86	43	43
502	Rough-In Ductwork - 1H	7/6/2004	7/21/2004	0	0	0
503	Rough-In Sprinkler - 1H	6/24/2004	7/13/2004	91	45.5	45.5
504	Rough-In Electrical - 1H	6/30/2004	7/22/2004	84	42	42
505	Insulate Plumbing Pipe - 1H	7/7/2004	7/20/2004	86	43	43
506	Insulate HVAC Pipe - 1H	7/7/2004	7/20/2004	86	43	43
507	Insulate Duct - 1H	7/22/2004	8/2/2004	77	38.5	38.5
508	Install Elevators, #1 - HOTEL	7/23/2004	8/12/2004	168	84	84
509	Install Elevators #2 - HOTEL	8/6/2004	8/26/2004	168	84	84
510	Install Elevators #3 - HOTEL	8/20/2004	9/10/2004	168	84	84
511	Install Lobby Studs & DW 1 Side - 1H	6/14/2004	6/23/2004	96	48	48
512	Install Wall RI Electric - 1H	6/24/2004	6/28/2004	108	54	54
513	Complete Lobby Drywall Walls - 1H	6/29/2004	7/9/2004	108	54	54
514	Build Lobby Fireplace - 1H	5/14/2004	6/1/2004	134	67	67
515	Install Lobby Ceiling - 1H	6/24/2004	7/9/2004	96	48	48
516	Install Lobby Tube Steel - 1H	7/12/2004	7/21/2004	96	48	48
517	Install Lobby Upper Handrails - 1H	7/22/2004	7/27/2004	96	48	48
518	Paint Lobby Base & 1st Coat - 1H	7/28/2004	8/3/2004	96	48	48
519	Install Lobby VWC - 1H	8/4/2004	8/9/2004	96	48	48
520	Install Lobby Ceramic Tile - 1H	8/10/2004	8/18/2004	96	48	48
521	Install Lobby Wood Trim - 1H	8/19/2004	8/26/2004	96	48	48
522	Install Lobby Expansion Joint Covers - 1H	8/27/2004	8/30/2004	96	48	48
523	Finish Paint Lobby - 1H	8/31/2004	9/7/2004	96	48	48
524	Install Lobby Front Desk - 1H	9/8/2004	9/10/2004	96	48	48
525	Install Lobby Carpet - 1H	10/21/2004	10/22/2004	68	34	34
526	Install Interior Wall Blocking - 1H	6/14/2004	6/17/2004	96	48	48
527	Install Tubs - 1H	6/18/2004	6/29/2004	96	48	48
528	Install Door Frames & Complete Wall - 1H	6/30/2004	7/9/2004	96	48	48
529	Pull Electric Wire to Panels - 1H	7/23/2004	8/9/2004	157	78.5	78.5
530	Install Unit Drywall Ceilings - 1H	8/3/2004	8/13/2004	77	38.5	38.5
531	Complete & Finish Unit Drywall - 1H	8/9/2004	9/3/2004	81	40.5	40.5
532	Install Corridor Drywall Ceilings - 1H	8/16/2004	8/20/2004	77	38.5	38.5
533	Furr & Drywall Corridor - 1H	8/23/2004	9/8/2004	77	38.5	38.5
534	Paint Base & 1st Coat - 1H	9/2/2004	9/16/2004	77	38.5	38.5
535	Install Window Sills - 1H	9/7/2004	9/14/2004	81	40.5	40.5
536	Install Acoustical Tile Ceiling Grid - 1H	9/17/2004	9/21/2004	77	38.5	38.5
537	Install Control Rough-Ins - 1H	9/22/2004	9/28/2004	77	38.5	38.5
538	Install Ceramic Tile in Toilets - 1H	9/7/2004	9/20/2004	148	74	74
539	Install Lights - 1H	8/10/2004	8/19/2004	157	78.5	78.5
540	Finish Paint - 1H	8/20/2004	8/27/2004	157	78.5	78.5
541	Install Counter Tops - 1H	8/30/2004	9/7/2004	157	78.5	78.5
542	Set Plumbing Fixtures - 1H	9/21/2004	10/4/2004	148	74	74
543	Install Sprinkler Heads - 1H	9/22/2004	9/27/2004	78	39	39
544	Install Vinyl Wall Cover in Units - 1H	9/15/2004	9/24/2004	81	40.5	40.5
545	Install Toilet Accessories - 1H	10/5/2004	10/8/2004	148	74	74
546	Install Mech Diffusers - 1H	9/22/2004	9/27/2004	78	39	39
547	Trim Electric - 1H	9/22/2004	10/4/2004	152	76	76
548	Install Closet Shelves - 1H	9/27/2004	9/29/2004	155	77.5	77.5
549	Install Doors/Hardware - 1H	9/27/2004	10/8/2004	148	74	74
550	Install FEC - 1H	9/27/2004	9/27/2004	81	40.5	40.5

Table A-1: Continued [pg. 12 of 20]

ID	Description	Start-Finish Database			ATF Database	
		Start	Finish	TF	Owner	Contractor
551	Install Ceiling Tile - 1H	9/29/2004	10/1/2004	77	38.5	38.5
552	Install Corridor VWC - 1H	10/4/2004	10/13/2004	77	38.5	38.5
553	Trim Controls - 1H	10/14/2004	10/18/2004	120	60	60
554	Install Carpet - 1H	10/25/2004	11/5/2004	68	34	34
555	Install Wood Base - 1H	11/8/2004	11/19/2004	118	59	59
556	Install Rubber Base - 1H	11/8/2004	11/15/2004	122	61	61
557	Final Clean - 1H	11/22/2004	11/30/2004	118	59	59
558	FOUNDATION - LOWER CONF. CENTER - 1st F	7/15/2003	11/10/2003	35	17.5	17.5
559	Establish Major Axis Lines - C	7/15/2003	7/15/2003	41	20.5	20.5
560	Layout Footings (North & South)- C	8/21/2003	9/2/2003	15	7.5	7.5
561	Drill Elevator Jack Hole - C	7/16/2003	7/18/2003	41	20.5	20.5
562	Excavate Footings - C	8/26/2003	9/5/2003	15	7.5	7.5
563	Form and Place Footings - C	8/27/2003	9/8/2003	15	7.5	7.5
564	Form and Place Concrete Walls - C	9/3/2003	9/23/2003	15	7.5	7.5
565	Waterproof Walls - C	9/24/2003	10/1/2003	15	7.5	7.5
566	Backfill and Compact - C	10/2/2003	10/15/2003	15	7.5	7.5
567	CMU to Finish SOG Floor - C	9/24/2003	9/30/2003	35	17.5	17.5
568	Stub Up Incoming Water Main Line - C	10/1/2003	10/2/2003	35	17.5	17.5
569	U.G. Plumbing - C	10/3/2003	10/15/2003	35	17.5	17.5
570	Slab Stone and Base 1st Floor - C	10/16/2003	10/22/2003	35	17.5	17.5
571	U.G. Electrical - C	10/23/2003	11/5/2003	35	17.5	17.5
572	Termite Treatment - C	11/6/2003	11/6/2003	35	17.5	17.5
573	Prep and Place Slab-on-Grade 1st Fl - C	11/7/2003	11/10/2003	35	17.5	17.5
574	FOUNDATION-MAIN LEVEL CONF.CENTER-2ndF	10/9/2003	12/10/2003	15	7.5	7.5
575	Layout Footings - C	10/10/2003	10/15/2003	15	7.5	7.5
576	Excavate Footings	10/10/2003	10/23/2003	15	7.5	7.5
577	Form and Place Footings - C	10/9/2003	10/22/2003	15	7.5	7.5
578	Prep & Place Loading Dock - C	10/23/2003	10/28/2003	44	22	22
579	CMU to Finish Floor - C	10/15/2003	11/4/2003	15	7.5	7.5
580	U.G. Plumbing - C	10/24/2003	11/10/2003	15	7.5	7.5
581	Install Kitchen UG Plumbing - C	11/11/2003	11/24/2003	15	7.5	7.5
582	Slab Stone and Base 2nd Floor - C	11/20/2003	11/25/2003	15	7.5	7.5
583	U.G. Electrical - C	11/20/2003	12/3/2003	15	7.5	7.5
584	Termite Treatment - C	12/4/2003	12/4/2003	15	7.5	7.5
585	Prep and Place SOG 2nd Fl - C	12/5/2003	12/10/2003	15	7.5	7.5
586	STRUCTURE CONFERENCE CENTER	12/11/2003	3/17/2004	15	7.5	7.5
587	Set Building Structural Steel - C	12/11/2003	1/14/2004	15	7.5	7.5
588	2nd Fl Lay Composite Metal Deck - C	1/15/2004	1/19/2004	15	7.5	7.5
589	2nd Fl Install Beam Studs - C	1/20/2004	1/22/2004	28	14	14
590	2nd Fl Prep and Place Slab-on-Deck - C	1/23/2004	1/26/2004	28	14	14
591	3rd Fl Lay Composite Metal Deck - C	1/20/2004	1/29/2004	15	7.5	7.5
592	3rd Fl Install Beam Studs - C	1/30/2004	2/9/2004	18	9	9
593	3rd Fl Prep and Place Slab-on-Deck - C	2/10/2004	2/13/2004	18	9	9
594	Roof Lay Composite Metal Deck - C	1/30/2004	2/10/2004	15	7.5	7.5
595	Roof Install Beam Studs - C	2/11/2004	2/13/2004	15	7.5	7.5
596	Roof Prep and Place Slab-on-Deck - C	2/16/2004	2/18/2004	15	7.5	7.5
597	Set HM Frames with CMU - C	2/19/2004	2/23/2004	15	7.5	7.5
598	Build CMU Elevator Towers 4&5 - C	2/24/2004	3/8/2004	15	7.5	7.5
599	Build CMU Stair Tower C1, C2, C3	2/26/2004	3/12/2004	15	7.5	7.5
600	Build CMU Clock Tower - C	2/26/2004	3/17/2004	15	7.5	7.5

Table A-1: Continued [pg. 13 of 20]

ID	Description	Start-Finish Database			ATF Database	
		Start	Finish	TF	Owner	Contractor
601	ROOF STRUCTURE - CONFERENCE CENTER	2/19/2004	4/12/2004	35	17.5	17.5
602	Set Bar Joists at Tower Roofs - C	3/18/2004	3/29/2004	15	7.5	7.5
603	Metal Deck at Tower Roofs - C	3/25/2004	4/1/2004	29	14.5	14.5
604	Place Slab-on Deck at CRU #1 Mech Units - C	2/19/2004	2/24/2004	98	49	49
605	Set CRU #1 Mech Eqpt On Roof - C	2/25/2004	3/1/2004	98	49	49
606	Set Hokie Stone at CRU #1 - C	3/2/2004	3/8/2004	98	49	49
607	Set Steel Stairs at Clock Tower - C	4/2/2004	4/12/2004	37	18.5	18.5
608	ROOFING - CONFERENCE CENTER	4/2/2004	6/18/2004	29	14.5	14.5
609	Metal Roofing - C	4/2/2004	4/15/2004	29	14.5	14.5
610	Wood Blocking - C	4/16/2004	4/22/2004	29	14.5	14.5
611	Roof Insulation - C	4/23/2004	5/13/2004	29	14.5	14.5
612	Roof Membrane - C	4/28/2004	5/18/2004	29	14.5	14.5
613	Miscellaneous Metal Flashing - C	5/13/2004	5/24/2004	220	110	110
614	Roof Scuppers - C	5/25/2004	6/2/2004	220	110	110
615	Gutter and Downspout - C	6/3/2004	6/18/2004	220	110	110
616	VENEER - CONFERENCE CENTER	3/30/2004	10/12/2004	15	7.5	7.5
617	Complete CMU 2nd FI Ext Walls North Side - C	3/30/2004	4/6/2004	15	7.5	7.5
618	Complete CMU 3rd FI Ext Walls North Side - C	4/7/2004	4/14/2004	15	7.5	7.5
619	Complete CMU 2nd FI Ext Walls West Side - C	4/15/2004	4/26/2004	15	7.5	7.5
620	Complete CMU 3rd FI Ext Walls West Side - C	4/27/2004	5/6/2004	15	7.5	7.5
621	Complete CMU 2nd FI Ext Walls East Side - C	5/7/2004	5/17/2004	15	7.5	7.5
622	Complete CMU 3rd FI Ext Walls East Side - C	5/18/2004	5/26/2004	15	7.5	7.5
623	Complete CMU 2nd FI Ext Walls South Side - C	5/27/2004	6/4/2004	15	7.5	7.5
624	Complete CMU 3rd FI Ext Walls South Side - C	6/7/2004	6/14/2004	15	7.5	7.5
625	Precast Concrete at North Windows - C	4/22/2004	5/5/2004	56	28	28
626	Precast Concrete at West Windows - C	5/6/2004	5/17/2004	63	31.5	31.5
627	Precast Concrete at East Windows - C	5/18/2004	5/24/2004	76	38	38
628	Precast Concrete at South Windows - C	6/15/2004	6/24/2004	72	36	36
629	Dampproof & Set Hokie Stone North - C	5/28/2004	6/18/2004	40	20	20
630	Dampproof & Set Hokie Stone West - C	6/21/2004	7/16/2004	40	20	20
631	Dampproof & Set Hokie Stone East - C	7/19/2004	8/11/2004	40	20	20
632	Dampproof & Set Hokie Stone South - C	8/12/2004	9/1/2004	40	20	20
633	Dampproof&Set Hokie Stone Clock Tower - C	9/2/2004	9/14/2004	147	73.5	73.5
634	Install Windows - C	8/12/2004	9/9/2004	160	80	80
635	Install Aluminum Ext Doors - C	9/2/2004	9/13/2004	158	79	79
636	Precast Concrete Coping - C	8/19/2004	9/9/2004	160	80	80
637	Set Exterior Door Frames - C	8/12/2004	8/13/2004	178	89	89
638	Sealants - C	9/15/2004	9/28/2004	147	73.5	73.5
639	Clean Veneer Stone - C	9/29/2004	10/12/2004	147	73.5	73.5
640	INTERIOR FINISH CONF CENTER - 3rd Floor	3/18/2004	3/21/2005	34	17	17
641	Install Operable Partition Supports&Tracks-3C	5/19/2004	5/24/2004	29	14.5	14.5
642	Spray Fireproof -3C	6/15/2004	6/24/2004	15	7.5	7.5
643	Install Metal Stairs - 3C	3/18/2004	3/31/2004	108	54	54
644	Pour Stair Pans - 3C	4/1/2004	4/6/2004	108	54	54
645	Install Drywall HM Frames - 3C	6/25/2004	6/30/2004	31	15.5	15.5
646	Install Studs & Drywall 1 Side - 3C	7/1/2004	7/23/2004	31	15.5	15.5
647	Rough-In Plumbing - 3C	6/25/2004	7/14/2004	18	9	9
648	Rough-In HVAC Piping - 3C	6/25/2004	7/19/2004	15	7.5	7.5
649	Rough-In Ductwork - 3C	7/22/2004	8/18/2004	0	0	0
650	Rough-In Sprinkler - 3C	6/25/2004	7/26/2004	43	21.5	21.5

Table A-1: Continued [pg. 14 of 20]

ID	Description	Start-Finish Database			ATF Database	
		Start	Finish	TF	Owner	Contractor
651	Rough-In Electrical - 3C	6/25/2004	7/26/2004	28	14	14
652	Insulate Plumbing Pipe - 3C	7/15/2004	8/4/2004	28	14	14
653	Insulate HVAC Pipe - 3C	7/20/2004	8/9/2004	25	12.5	12.5
654	Insulate Duct - 3C	8/19/2004	9/9/2004	18	9	9
655	Install Wall Blocking - 3C	7/26/2004	8/2/2004	33	16.5	16.5
656	Pull Electric Wire to Panels - 3C	7/27/2004	8/16/2004	132	66	66
657	Install Elevators #4 - CONFERENCE	8/17/2004	9/7/2004	132	66	66
658	Install Elevators #5 - CONFERENCE	9/8/2004	9/28/2004	132	66	66
659	Install Elevators #6 - CONFERENCE	9/29/2004	10/19/2004	132	66	66
660	Complete Drywall Walls - 3C	8/10/2004	8/25/2004	28	14	14
661	Install Toilet Drywall Ceilings - 3C	9/10/2004	9/17/2004	41	20.5	20.5
662	Install Drywall Bulkheads & Ceilings - 3C	8/26/2004	9/16/2004	28	14	14
663	Paint Base & 1st Coat - 3C	9/17/2004	10/4/2004	59	29.5	29.5
664	Install Toilet Ceramic Tile - 3C	9/20/2004	10/1/2004	41	20.5	20.5
665	Install Ballroom Drywall Bulkheads - 3C	9/10/2004	9/30/2004	18	9	9
666	Install Acoustic Ceiling Grids - 3C	10/1/2004	10/12/2004	18	9	9
667	Install Control Rough-Ins - 3C	10/13/2004	10/26/2004	114	57	57
668	Trim Above Ceiling Mechanical - 3C	10/13/2004	10/26/2004	114	57	57
669	Install Lights - 3C	10/13/2004	11/2/2004	18	9	9
670	Install Sprinkler Heads - 3C	10/13/2004	10/26/2004	66	33	33
671	Install Plumbing Fixtures - 3C	10/4/2004	10/15/2004	41	20.5	20.5
672	Install Toilet Partitions - 3C	10/18/2004	10/25/2004	41	20.5	20.5
673	Install Toilet Accessories - 3C	10/26/2004	10/28/2004	41	20.5	20.5
674	Install Wood Trim - 3C	11/3/2004	11/23/2004	18	9	9
675	Install Acoustical Wall Panels	11/24/2004	12/2/2004	18	9	9
676	Finish Paint - 3C	12/3/2004	12/16/2004	18	9	9
677	Install Wood Paneling - 3C	12/17/2004	12/28/2004	70	35	35
678	Install VWC - 3C	12/10/2004	1/10/2005	18	9	9
679	Trim Controls - 3C	1/11/2005	1/24/2005	64	32	32
680	Install VCT - 3C	1/11/2005	1/17/2005	18	9	9
681	Install Operable Walls - 3C	12/3/2004	12/8/2004	47	23.5	23.5
682	Install Projection Screens - 3C	10/13/2004	10/18/2004	72	36	36
683	Install Casework - 3C	1/18/2005	1/27/2005	18	9	9
684	Install Ceiling Tile - 3C	11/3/2004	11/16/2004	61	30.5	30.5
685	Trim Electric - 3C	1/11/2005	1/17/2005	72	36	36
686	Install Doors & Hardware - 3C	1/28/2005	2/17/2005	34	17	17
687	Install Carpet - 3C	1/21/2005	2/10/2005	18	9	9
688	Install FEC - 3C	1/18/2005	1/18/2005	71	35.5	35.5
689	Install Wood Base - 3C	2/18/2005	3/10/2005	34	17	17
690	Install Rubber Base - 3C	1/18/2005	1/26/2005	65	32.5	32.5
691	Final Clean - 3C	3/11/2005	3/21/2005	34	17	17
692	INTERIOR FINISH CONF CENTER - 2nd Floor	5/25/2004	4/25/2005	16	8	8
693	Install Operable Partition Supports&Tracks-2C	5/25/2004	6/15/2004	32	16	16
694	Spray Fireproof -2C	6/25/2004	7/12/2004	20	10	10
695	Install CMU HM Frames -2C	7/13/2004	7/16/2004	46	23	23
696	Complete Interior CMU Walls - 2C	7/19/2004	8/6/2004	148	74	74
697	Install Drywall HM Frames - 2C	7/19/2004	7/22/2004	46	23	23
698	Install Studs & Drywall 1 Side - 2C	7/26/2004	8/10/2004	31	15.5	15.5
699	Rough-In Plumbing - 2C	7/15/2004	8/11/2004	18	9	9
700	Rough-In HVAC Piping - 2C	7/20/2004	8/16/2004	15	7.5	7.5

Table A-1: Continued [pg. 15 of 20]

ID	Description	Start-Finish Database			ATF Database	
		Start	Finish	TF	Owner	Contractor
701	Rough-In Ductwork - 2C	8/19/2004	9/14/2004	0	0	0
702	Rough-In Sprinkler - 2C	7/27/2004	8/16/2004	43	21.5	21.5
703	Rough-In Electrical - 2C	7/27/2004	8/16/2004	28	14	14
704	Insulate Plumbing Pipe - 2C	8/5/2004	8/25/2004	28	14	14
705	Insulate HVAC Pipe - 2C	8/10/2004	8/30/2004	25	12.5	12.5
706	Insulate Duct - 2C	9/15/2004	10/5/2004	15	7.5	7.5
707	Install Wall Blocking - 2C	7/23/2004	7/30/2004	46	23	23
708	Pull Electric Wire to Panels - 2C	8/17/2004	9/7/2004	72	36	36
709	Complete Drywall Walls - 2C	8/31/2004	9/22/2004	25	12.5	12.5
710	Install Toilet Drywall Ceilings - 2C	10/6/2004	10/13/2004	16	8	8
711	Install Drywall Bulkheads & Ceilings - 2C	10/14/2004	11/3/2004	16	8	8
712	Paint Base & 1st Coat - 2C	11/4/2004	11/24/2004	16	8	8
713	Install Cold Storage Units - 2C	8/9/2004	8/12/2004	148	74	74
714	Install Kitchen Exhaust Hoods - 2C	9/15/2004	9/17/2004	123	61.5	61.5
715	Install Kitchen Quarry Tile - 2C	9/20/2004	10/5/2004	123	61.5	61.5
716	Install Toilet Ceramic Tile - 2C	10/14/2004	10/27/2004	65	32.5	32.5
717	Install Acoustic Ceiling Grids - 2C	11/29/2004	12/10/2004	16	8	8
718	Install Control Rough-Ins - 2C	12/13/2004	12/27/2004	83	41.5	41.5
719	Trim Above Ceiling Mechanical - 2C	12/13/2004	12/27/2004	83	41.5	41.5
720	Install Lights - 2C	12/13/2004	1/4/2005	16	8	8
721	install Sprinkler Heads - 2C	12/13/2004	12/27/2004	61	30.5	30.5
722	Install C122 Wood Frame Window - 2C	11/29/2004	12/1/2004	60	30	30
723	Finish Paint Kitchen - 2C	1/5/2005	1/7/2005	62	31	31
724	Install Kitchen Equipment - 2C	1/10/2005	1/28/2005	62	31	31
725	Connect Plumbing to Kitchen Eqpt - 2C	1/20/2005	1/31/2005	62	31	31
726	Connect Electrical to Kitchen Eqpt - 2C	1/20/2005	1/31/2005	62	31	31
727	Install Plumbing Fixtures - 2C	10/28/2004	11/8/2004	65	32.5	32.5
728	Install Toilet Partitions - 2C	11/9/2004	11/16/2004	65	32.5	32.5
729	Install Toilet Accessories - 2C	11/17/2004	11/22/2004	65	32.5	32.5
730	Install Wood Trim - 2C	12/20/2004	1/18/2005	16	8	8
731	Install Ballroom Acoustic Wall Panels - 2C	1/19/2005	2/3/2005	16	8	8
732	Finish Paint - 2C	2/4/2005	2/24/2005	16	8	8
733	Install Wood Paneling - 2C	2/25/2005	3/3/2005	16	8	8
734	Install VWC - 2C	3/4/2005	3/31/2005	16	8	8
735	Trim Controls - 2C	4/1/2005	4/14/2005	16	8	8
736	Install VCT - 2C	2/25/2005	3/3/2005	39	19.5	19.5
737	Install Lockers - 2C	2/25/2005	3/2/2005	47	23.5	23.5
738	Install Ballroom Operable Walls - 2C	2/4/2005	2/25/2005	25	12.5	12.5
739	Install Ballroom Projection Screens - 2C	12/13/2004	12/20/2004	68	34	34
740	Install Casework - 2C	2/25/2005	3/14/2005	27	13.5	13.5
741	Install Ceiling Tile - 2C	1/5/2005	1/18/2005	56	28	28
742	Trim Electric - 2C	4/1/2005	4/11/2005	19	9.5	9.5
743	Install Ballroom Ceiling Tile - 2C	2/22/2005	3/2/2005	25	12.5	12.5
744	Install Doors & Hardware - 2C	1/5/2005	1/25/2005	61	30.5	30.5
745	Install Carpet - 2C	3/4/2005	3/24/2005	24	12	12
746	Install FEC - 2C	3/4/2005	3/4/2005	45	22.5	22.5
747	Install Wood Base - 2C	3/18/2005	4/4/2005	24	12	12
748	Install Rubber Base - 2C	3/4/2005	3/14/2005	39	19.5	19.5
749	Final Clean - 2C	4/15/2005	4/25/2005	16	8	8

Table A-1: Continued [pg. 16 of 20]

ID	Description	Start-Finish Database			ATF Database	
		Start	Finish	TF	Owner	Contractor
750	INTERIOR FINISH CONF CENTER - 1st Floor	7/13/2004	11/29/2004	35	17.5	17.5
751	Spray Fireproof -1C	7/13/2004	7/16/2004	35	17.5	17.5
752	Install CMU HM Frames -1C	7/19/2004	7/20/2004	35	17.5	17.5
753	Complete Interior CMU Walls - 1C	7/21/2004	8/10/2004	35	17.5	17.5
754	Install Boiler/Chiller Room Drywall Ceiling	8/11/2004	8/18/2004	119	59.5	59.5
755	Install Mechanical Support Structure Grid	8/19/2004	8/24/2004	119	59.5	59.5
756	Pour Equipment Pads	8/25/2004	8/30/2004	119	59.5	59.5
757	Set Boiler	8/31/2004	9/1/2004	119	59.5	59.5
758	Set Chiller	8/31/2004	9/1/2004	119	59.5	59.5
759	Set AHU	8/31/2004	8/31/2004	120	60	60
760	Set Pumps	8/31/2004	9/1/2004	119	59.5	59.5
761	Set Control Air Compressor	8/31/2004	8/31/2004	120	60	60
762	Set Water Heaters	8/25/2004	8/25/2004	124	62	62
763	Complete Masonry MR Exterior Wall - C	9/2/2004	9/16/2004	119	59.5	59.5
764	Install MR Domestic Water Piping	8/26/2004	8/31/2004	166	83	83
765	Install MR HVAC Piping	9/17/2004	10/4/2004	119	59.5	59.5
766	Install MR Ductwork	10/5/2004	10/25/2004	119	59.5	59.5
767	Install MR Sprinkler Piping	10/26/2004	10/29/2004	119	59.5	59.5
768	Install MR Electrical Roughin	9/10/2004	9/23/2004	152	76	76
769	Install MR Controls	9/10/2004	9/23/2004	157	78.5	78.5
770	Install MR Duct/Pipe Insulation	10/26/2004	11/8/2004	128	64	64
771	Install MR Lights	9/24/2004	9/30/2004	152	76	76
772	Set Switchgear	10/15/2004	10/22/2004	124	62	62
773	Complete Electrical Connections to Equipment	11/1/2004	11/12/2004	119	59.5	59.5
774	Install Permanent Electric Power	11/15/2004	11/16/2004	119	59.5	59.5
775	Complete MR Pipe Identification	11/9/2004	11/10/2004	128	64	64
776	Equipment Startup	11/17/2004	11/23/2004	119	59.5	59.5
777	Rough-In Plumbing - 1C	8/12/2004	8/25/2004	18	9	9
778	Rough-In HVAC Piping - 1C	8/17/2004	8/30/2004	15	7.5	7.5
779	Rough-In Ductwork - 1C	9/15/2004	9/28/2004	0	0	0
780	Rough-In Sprinkler - 1C	8/17/2004	8/24/2004	43	21.5	21.5
781	Rough-In Electrical - 1C	8/17/2004	8/30/2004	28	14	14
782	Insulate Plumbing Pipe - 1C	8/26/2004	9/2/2004	29	14.5	14.5
783	Insulate HVAC Pipe - 1C	8/31/2004	9/8/2004	26	13	13
784	Insulate Duct - 1C	10/6/2004	10/15/2004	15	7.5	7.5
785	Pull Electric Wire to Panels - 1C	8/31/2004	9/3/2004	160	80	80
786	Paint Base & 1st Coat - 1C	8/11/2004	8/20/2004	163	81.5	81.5
787	Install Drywall Ceilings - 1C	10/18/2004	10/21/2004	124	62	62
788	Install Acoustic Ceiling Grids - 1C	10/22/2004	10/26/2004	124	62	62
789	Install Control Rough-Ins - 1C	10/27/2004	11/4/2004	131	65.5	65.5
790	Trim Above Ceiling Mechanical - 1C	10/27/2004	11/1/2004	129	64.5	64.5
791	Install Lights - 1C	10/27/2004	11/1/2004	124	62	62
792	install Sprinkler Heads - 1C	10/27/2004	10/28/2004	131	65.5	65.5
793	Finish Paint - 1C	11/2/2004	11/8/2004	124	62	62
794	Trim Controls - 1C	11/5/2004	11/5/2004	131	65.5	65.5
795	Install VCT - 1C	11/9/2004	11/11/2004	124	62	62
796	Install Ceiling Tile - 1C	11/12/2004	11/15/2004	125	62.5	62.5
797	Trim Electric - 1C	11/9/2004	11/15/2004	125	62.5	62.5
798	Install Doors & Hardware - 1C	11/12/2004	11/15/2004	124	62	62
799	Install FEC - 1C	11/16/2004	11/16/2004	124	62	62
800	Install Rubber Base - 1C	11/12/2004	11/15/2004	125	62.5	62.5

Table A-1: Continued [pg. 17 of 20]

ID	Description	Start-Finish Database			ATF Database	
		Start	Finish	TF	Owner	Contractor
801	Final Clean - 1C	11/24/2004	11/29/2004	119	59.5	59.5
802	FOUNDATION - ALUMNI CENTER	7/16/2003	11/24/2003	143	71.5	71.5
803	Layout Major Axis Lines - A	7/16/2003	7/16/2003	143	71.5	71.5
804	Probe Holes	7/17/2003	7/30/2003	143	71.5	71.5
805	Layout Footings - A	9/3/2003	9/5/2003	120	60	60
806	Excavate Footings - A	9/8/2003	9/25/2003	120	60	60
807	Form and Place Footings - A	9/9/2003	9/26/2003	120	60	60
808	Form and Place Concrete Walls - A	9/15/2003	9/24/2003	123	61.5	61.5
809	Waterproof Walls - A	9/25/2003	9/26/2003	133	66.5	66.5
810	CMU to Finish Floor - A	9/23/2003	9/29/2003	120	60	60
811	U.G. Plumbing - A	9/30/2003	10/15/2003	120	60	60
812	Slab Stone Base - A	10/16/2003	10/17/2003	120	60	60
813	U.G. Electrical - A	10/20/2003	10/28/2003	120	60	60
814	Termite Treatment - A	10/29/2003	10/29/2003	120	60	60
815	Prep and Place Slab-on-Grade - A	10/30/2003	10/31/2003	120	60	60
816	Prep and Place Concrete at Auditorium Steps - A	11/3/2003	11/21/2003	204	102	102
817	Set HM Frames - A	11/3/2003	11/4/2003	120	60	60
818	CMU to Bearing - 2nd floor - A	11/5/2003	11/24/2003	120	60	60
819	STRUCTURE ALUMNI CENTER	1/15/2004	4/5/2004	90	45	45
820	Set Structural Steel - A	1/15/2004	2/4/2004	90	45	45
821	Set Bar Joists - A	2/5/2004	2/13/2004	90	45	45
822	2nd FI Lay Composite Metal Floor Deck - A	2/16/2004	2/19/2004	90	45	45
823	2nd FI Install Beam Studs - A	2/20/2004	2/25/2004	90	45	45
824	2nd FI Prep and Place Slab-on-Deck - A	2/26/2004	2/27/2004	94	47	47
825	3rd FI Lay Composite Metal Floor Deck - A	2/20/2004	2/25/2004	90	45	45
826	3rd FI Install Beam Studs - A	2/26/2004	3/2/2004	90	45	45
827	3rd FI Prep and Place Slab-on-Deck - A	3/1/2004	3/2/2004	94	47	47
828	Set Bar Joists - Roof - A	2/16/2004	2/25/2004	90	45	45
829	Install Metal Roof Deck - A	2/26/2004	3/2/2004	90	45	45
830	Roof Install Beam Studs - A	3/3/2004	3/3/2004	90	45	45
831	Form & Pour CRU #2 Mech Slab on Roof	3/4/2004	3/8/2004	90	45	45
832	Set CRU #2 Mech Eqpt On Roof	3/9/2004	3/12/2004	90	45	45
833	Metal Stud Framing at Roof - A	3/15/2004	3/30/2004	91	45.5	45.5
834	Install Attic Walkway	3/31/2004	4/5/2004	110	55	55
835	ROOF ALUMNI CENTER	3/31/2004	7/6/2004	91	45.5	45.5
836	Metal Roofing - A	3/31/2004	4/27/2004	91	45.5	45.5
837	Wood Blocking - A	3/31/2004	4/9/2004	109	54.5	54.5
838	Roof Insulation - A	4/28/2004	5/5/2004	91	45.5	45.5
839	Roof Membrane - A	5/6/2004	5/13/2004	91	45.5	45.5
840	Miscellaneous Metal Flashing - A	5/14/2004	5/25/2004	233	116.5	116.5
841	Roof Scuppers - A	5/26/2004	6/1/2004	233	116.5	116.5
842	Gutter and Downspouts - A	6/21/2004	7/6/2004	220	110	110
843	EXTERIOR VENEER ALUMNI CENTER	6/15/2004	12/21/2004	25	12.5	12.5
844	Install East CMU Exterior Walls - A	6/15/2004	6/25/2004	25	12.5	12.5
845	Install South CMU Exterior Walls - A	6/28/2004	7/12/2004	25	12.5	12.5
846	Install West CMU Exterior Walls - A	7/13/2004	7/23/2004	25	12.5	12.5
847	Install North CMU Exterior Walls - A	7/26/2004	8/5/2004	25	12.5	12.5
848	Install Precast Windows East Side - A	6/28/2004	7/8/2004	79	39.5	39.5
849	Install Precast Windows South Side- A	7/13/2004	7/23/2004	81	40.5	40.5
850	Install Precast Windows West Side - A	7/26/2004	8/2/2004	90	45	45

Table A-1: Continued [pg. 18 of 20]

ID	Description	Start-Finish Database			ATF Database	
		Start	Finish	TF	Owner	Contractor
851	Install Precast Windows North Side - A	8/6/2004	8/16/2004	93	46.5	46.5
852	Dampproof & Set Hokie Stone East - A	9/2/2004	9/21/2004	40	20	20
853	Dampproof & Set Hokie Stone South - A	9/22/2004	10/12/2004	40	20	20
854	Dampproof & Set Hokie Stone West - A	10/13/2004	10/29/2004	40	20	20
855	Dampproof & Set Hokie Stone North - A	11/1/2004	11/15/2004	40	20	20
856	Install Windows - A	11/2/2004	11/22/2004	40	20	20
857	Precast Concrete Coping - A	11/9/2004	11/22/2004	108	54	54
858	Set Exterior Door Frames - A	11/16/2004	12/1/2004	103	51.5	51.5
859	Sealants - A	12/2/2004	12/15/2004	103	51.5	51.5
860	Clean Veneer Stone - A	12/16/2004	12/21/2004	103	51.5	51.5
861	INTERIOR FINISH ALUMNI CENTER - 3RD FLOOR	8/6/2004	3/23/2005	25	12.5	12.5
862	Install Spray Fireproofing - 3A	8/6/2004	8/12/2004	25	12.5	12.5
863	Install Stairs - A	8/13/2004	8/26/2004	90	45	45
864	Pour Pan Stairs - A	8/27/2004	8/31/2004	90	45	45
865	Rough-In Plumbing - 3A	8/26/2004	9/7/2004	18	9	9
866	Rough-In HVAC Piping - 3A	8/27/2004	9/10/2004	15	7.5	7.5
867	Rough-In Ductwork - 3A	9/29/2004	10/19/2004	0	0	0
868	Rough-In Sprinkler - 3A	8/25/2004	9/3/2004	43	21.5	21.5
869	Rough-In Electrical - 3A	8/31/2004	9/16/2004	28	14	14
870	Insulate Plumbing Pipe - 3A	9/8/2004	9/15/2004	27	13.5	13.5
871	Insulate HVAC Pipe - 3A	9/13/2004	9/20/2004	24	12	12
872	Insulate Duct - 3A	10/20/2004	10/29/2004	13	6.5	6.5
873	Install Drywall HM Frames - 3A	8/13/2004	8/18/2004	25	12.5	12.5
874	Install Studs & Drywall 1 Side - 3A	8/19/2004	9/3/2004	25	12.5	12.5
875	Pull Electric Wire to Panels - 3A	9/7/2004	9/16/2004	95	47.5	47.5
876	Install Wall Blocking - 3A	9/7/2004	9/9/2004	54	27	27
877	Complete Drywall Walls - 3A	9/21/2004	10/18/2004	47	23.5	23.5
878	Install Toilet Drywall Ceilings - 3A	11/1/2004	11/4/2004	44	22	22
879	Install Drywall Bulkhead Ceilings - 3A	10/19/2004	11/1/2004	47	23.5	23.5
880	Paint Base & 1st Coat - 3A	11/5/2004	11/18/2004	44	22	22
881	Install Toilet Ceramic Tile - 3A	11/19/2004	11/30/2004	47	23.5	23.5
882	Install Acoustical Grid - 3A	11/19/2004	12/2/2004	50	25	25
883	Rough-in Controls - 3A	12/3/2004	12/13/2004	92	46	46
884	Trim Mechanical Above Ceiling - 3A	12/3/2004	12/14/2004	50	25	25
885	Install Sprinkler Heads - 3A	12/3/2004	12/9/2004	53	26.5	26.5
886	Install Electrical Lights - 3A	12/3/2004	12/14/2004	50	25	25
887	Install Wood Trim - 3A	11/19/2004	12/8/2004	44	22	22
888	Install Casework - 3A	12/9/2004	12/22/2004	44	22	22
889	Install Plumbing Fixtures - 3A	12/1/2004	12/7/2004	47	23.5	23.5
890	Install Toilet Partitions - 3A	12/8/2004	12/13/2004	47	23.5	23.5
891	Install Toilet Accessories - 3A	12/14/2004	12/17/2004	47	23.5	23.5
892	Finish Paint - 3A	12/23/2004	1/5/2005	44	22	22
893	Trim Controls - 3A	1/6/2005	1/10/2005	77	38.5	38.5
894	Install VCT - 3A	1/6/2005	1/10/2005	70	35	35
895	Install Ceiling Tile - 3A	12/15/2004	12/17/2004	55	27.5	27.5
896	Install Projection Screens - 3A	12/15/2004	12/17/2004	91	45.5	45.5
897	Trim Electric - 3A	1/6/2005	1/11/2005	76	38	38
898	Install Doors & Hardware - 3A	1/11/2005	1/19/2005	70	35	35
899	Install Carpet - 3A	2/11/2005	3/3/2005	18	9	9
900	Install Wood Base - 3A	3/4/2005	3/17/2005	29	14.5	14.5

Table A-1: Continued [pg. 19 of 20]

ID	Description	Start-Finish Database			ATF Database	
		Start	Finish	TF	Owner	Contractor
901	Install Rubber Base - 3A	1/6/2005	1/12/2005	75	37.5	37.5
902	Final Clean - 3A	3/18/2005	3/23/2005	29	14.5	14.5
903	INTERIOR FINISH ALUMNI CENTER - 2ND FLOOR	8/13/2004	4/13/2005	19	9.5	9.5
904	Install Spray Fireproofing - 2A	8/13/2004	8/19/2004	30	15	15
905	Rough-In Plumbing - 2A	9/8/2004	9/28/2004	18	9	9
906	Rough-In HVAC Piping - 2A	9/13/2004	10/1/2004	15	7.5	7.5
907	Rough-In Ductwork - 2A	10/20/2004	11/9/2004	0	0	0
908	Rough-In Sprinkler - 2A	9/7/2004	9/22/2004	43	21.5	21.5
909	Rough-In Electrical - 2A	9/17/2004	10/7/2004	28	14	14
910	Insulate Plumbing Pipe - 2A	9/29/2004	10/12/2004	18	9	9
911	Insulate HVAC Pipe - 2A	10/4/2004	10/15/2004	15	7.5	7.5
912	Insulate Duct - 2A	11/4/2004	11/17/2004	10	5	5
913	Install Drywall HM Frames - 2A	8/20/2004	8/24/2004	33	16.5	16.5
914	Install Studs & Drywall 1 Side - 2A	9/7/2004	9/24/2004	25	12.5	12.5
915	Pull Electric Wire to Panels - 2A	10/8/2004	10/19/2004	63	31.5	31.5
916	Install Wall Blocking - 2A	9/27/2004	9/30/2004	26	13	13
917	Complete Drywall Walls - 2C	10/18/2004	11/10/2004	15	7.5	7.5
918	Install Toilet Drywall Ceilings - 2A	11/18/2004	11/23/2004	18	9	9
919	Install Drywall Bulkhead Ceilings - 2A	11/18/2004	12/7/2004	10	5	5
920	Paint Base & 1st Coat - 2A	12/8/2004	12/21/2004	10	5	5
921	Install Toilet Ceramic Tile - 2A	11/24/2004	12/3/2004	55	27.5	27.5
922	Install Acoustical Grid - 2A	12/22/2004	1/6/2005	10	5	5
923	Rough-in Controls - 2A	1/7/2005	1/18/2005	76	38	38
924	Trim Mechanical Above Ceiling - 2A	1/7/2005	1/17/2005	39	19.5	19.5
925	Install Sprinkler Heads - 2A	1/7/2005	1/13/2005	41	20.5	20.5
926	Install Electrical Lights - 2A	1/7/2005	1/20/2005	10	5	5
927	Install Wall Paneling - 2A	1/21/2005	1/28/2005	10	5	5
928	Install Wood Trim - 2A	1/31/2005	2/15/2005	10	5	5
929	Install Casework - 2A	2/16/2005	2/25/2005	10	5	5
930	Install Plumbing Fixtures - 2A	12/6/2004	12/10/2004	55	27.5	27.5
931	Install Toilet Partitions - 2A	12/13/2004	12/16/2004	55	27.5	27.5
932	Install Toilet Accessories - 2A	12/17/2004	12/22/2004	55	27.5	27.5
933	Finish Paint - 2A	2/28/2005	3/15/2005	10	5	5
934	Trim Controls - 2A	3/16/2005	3/17/2005	36	18	18
935	Install VCT - 2A	3/16/2005	3/29/2005	19	9.5	9.5
936	Install Ceiling Tile - 2A	1/21/2005	1/25/2005	45	22.5	22.5
937	Install Projection Screens - 2A	1/26/2005	2/1/2005	65	32.5	32.5
938	Trim Electric - 2A	3/16/2005	3/21/2005	31	15.5	15.5
939	Install Doors & Hardware - 2A	3/30/2005	4/6/2005	19	9.5	9.5
940	Install Carpet - 2A	3/16/2005	3/29/2005	10	5	5
941	Install Wood Base - 2A	3/23/2005	4/5/2005	20	10	10
942	Install Rubber Base - 2A	3/30/2005	4/5/2005	20	10	10
943	Final Clean - 2A	4/7/2005	4/13/2005	19	9.5	9.5
944	INTERIOR FINISH ALUMNI CENTER - 1st FLOOR	8/20/2004	5/18/2005	0	0	0
945	Install Spray Fireproofing - 1A	8/20/2004	8/27/2004	37	18.5	18.5
946	Rough-In Plumbing - 1A	9/29/2004	10/14/2004	23	11.5	11.5
947	Rough-In HVAC Piping - 1A	10/4/2004	10/19/2004	20	10	10
948	Rough-In Ductwork - 1A	11/10/2004	11/29/2004	0	0	0
949	Rough-In Sprinkler - 1A	9/23/2004	10/4/2004	43	21.5	21.5
950	Rough-In Electrical - 1A	10/8/2004	10/25/2004	28	14	14

Table A-1: Continued [pg. 20 of 20]

ID	Description	Start-Finish Database			ATF Database	
		Start	Finish	TF	Owner	Contractor
951	Insulate Plumbing Pipe - 1A	10/15/2004	10/26/2004	23	11.5	11.5
952	Insulate HVAC Pipe - 1A	10/20/2004	10/29/2004	20	10	10
953	Insulate Duct - 1A	11/22/2004	12/3/2004	0	0	0
954	Install Drywall HM Frames - 1A	8/30/2004	9/8/2004	37	18.5	18.5
955	Install Studs & Drywall 1 Side - 1A	9/27/2004	10/15/2004	25	12.5	12.5
956	Pull Electric Wire to Panels - 1A	10/18/2004	10/29/2004	61	30.5	30.5
957	Install Wall Blocking - 1A	10/18/2004	10/22/2004	25	12.5	12.5
958	Paint Black Auditorium Ceiling - 1A	11/1/2004	11/5/2004	24	12	12
959	Install Auditorium Clouds - 1A	12/6/2004	12/16/2004	6	3	3
960	Complete Drywall Walls - 1C	11/1/2004	11/24/2004	20	10	10
961	Install Toilet Drywall Ceilings - 1A	12/6/2004	12/13/2004	9	4.5	4.5
962	Install Drywall Bulkhead Ceilings - 1A	12/6/2004	12/27/2004	0	0	0
963	Install Terrazzo Floor - 1A	12/28/2004	1/13/2005	23	11.5	11.5
964	Paint Base & 1st Coat - 1A	12/28/2004	1/11/2005	0	0	0
965	Install Toilet Ceramic Tile - 1A	12/14/2004	12/23/2004	45	22.5	22.5
966	Install Acoustical Grid - 1A	1/12/2005	1/25/2005	0	0	0
967	Rough-in Controls - 1A	1/26/2005	2/4/2005	0	0	0
968	Trim Mechanical Above Ceiling - 1A	1/26/2005	2/4/2005	0	0	0
969	Install Sprinkler Heads - 1A	1/26/2005	2/2/2005	2	1	1
970	Install Electrical Lights - 1A	1/26/2005	2/8/2005	3	1.5	1.5
971	Install Auditorium Fibreglas Wall Panels - 1A	1/26/2005	2/1/2005	3	1.5	1.5
972	Install Wood Paneling - 1A	2/7/2005	2/22/2005	0	0	0
973	Install Wood Trim - 1A	2/16/2005	3/1/2005	0	0	0
974	Install Casework - 1A	3/2/2005	3/17/2005	0	0	0
975	Install Plumbing Fixtures - 1A	12/27/2004	1/3/2005	45	22.5	22.5
976	Install Toilet Partitions - 1A	1/4/2005	1/7/2005	45	22.5	22.5
977	Install Toilet Accessories - 1A	1/10/2005	1/13/2005	45	22.5	22.5
978	Finish Paint - 1A	3/18/2005	3/31/2005	0	0	0
979	Trim Controls - 1A	4/1/2005	4/4/2005	26	13	13
980	Install VCT - 1A	4/1/2005	4/4/2005	0	0	0
981	Install Ceiling Tile - 1A	2/9/2005	2/11/2005	42	21	21
982	Install Projection Screens - 1A	4/1/2005	4/5/2005	25	12.5	12.5
983	Trim Electric - 1A	4/1/2005	4/7/2005	23	11.5	11.5
984	Install Doors and Hardware - 1A	4/5/2005	4/14/2005	0	0	0
985	Install Carpet - 1A	4/1/2005	4/14/2005	8	4	4
986	Install Cork Floor - 1A	4/15/2005	4/26/2005	0	0	0
987	Install Wood Base - 1A	4/20/2005	5/3/2005	5	2.5	2.5
988	Owner Installed Casework - 1A	4/27/2005	5/2/2005	6	3	3
989	Install Wood/Glass Casework - 1A	4/27/2005	5/10/2005	0	0	0
990	Install Rubber Base - 1A	4/5/2005	4/7/2005	23	11.5	11.5
991	Final Clean - 1A	5/11/2005	5/17/2005	0	0	0
992	Project Finish	5/18/2005	5/18/2005	0	0	0
993	SUBSTANTIAL COMPLETION	5/19/2005	5/19/2005	0	0	0

Appendix B

Start-Finish Database for June 2003

Table B-1: The Start-Finish database for the June 2003 Update

ID	As-Planned Schedule			20-Jun-03			June 24, 2003 (Rescheduled)		
	Start	Finish	TF	Start	Finish	TF	Start	Finish	TF
1	4/15/2003	4/15/2003	0	4/21/2003	4/21/2003	0	4/21/2003	4/21/2003	0
2	4/15/2003	5/29/2003	75	4/15/2003	7/24/2003	386	5/7/2003	8/8/2003	381
3	4/15/2003	4/24/2003	273	4/15/2003	4/24/2003	259	6/25/2003	7/7/2003	215
4	5/9/2003	5/9/2003	273	5/9/2003	5/9/2003	259	7/22/2003	7/22/2003	215
5	4/15/2003	4/15/2003	87	6/20/2003	6/20/2003	26	6/20/2003	6/25/2003	29
6	4/30/2003	4/30/2003	87	7/8/2003	7/8/2003	26	7/11/2003	7/11/2003	29
7	4/15/2003	4/15/2003	200	4/15/2003	4/15/2003	186	6/25/2003	6/25/2003	142
8	4/30/2003	4/30/2003	200	4/30/2003	4/30/2003	186	7/11/2003	7/11/2003	142
9	4/15/2003	4/15/2003	103	4/15/2003	4/15/2003	89	6/25/2003	6/25/2003	45
10	4/30/2003	4/30/2003	103	4/30/2003	4/30/2003	89	7/11/2003	7/11/2003	45
11	4/15/2003	4/15/2003	202	4/15/2003	4/15/2003	188	6/25/2003	6/25/2003	144
12	4/30/2003	4/30/2003	202	4/30/2003	4/30/2003	188	7/11/2003	7/11/2003	144
13	4/15/2003	4/17/2003	75	6/9/2003	6/11/2003	0	6/9/2003	6/11/2003	0
14	5/2/2003	5/2/2003	75	6/26/2003	6/26/2003	23	6/26/2003	6/26/2003	29
15	4/15/2003	4/15/2003	130	4/15/2003	4/15/2003	116	6/25/2003	6/25/2003	72
16	4/30/2003	4/30/2003	130	4/30/2003	4/30/2003	116	7/11/2003	7/11/2003	72
17	4/15/2003	4/15/2003	225	4/15/2003	4/15/2003	211	6/25/2003	6/25/2003	167
18	4/30/2003	4/30/2003	225	4/30/2003	4/30/2003	211	7/11/2003	7/11/2003	167
19	4/15/2003	4/23/2003	144	4/15/2003	4/23/2003	130	6/25/2003	7/3/2003	86
20	5/8/2003	5/8/2003	144	5/8/2003	5/8/2003	130	7/21/2003	7/21/2003	86
21	4/15/2003	5/1/2003	97	6/20/2003	7/9/2003	36	6/20/2003	7/9/2003	42
22	5/16/2003	5/16/2003	97	7/24/2003	7/24/2003	36	7/24/2003	7/24/2003	42
23	4/15/2003	4/15/2003	430	4/15/2003	4/15/2003	416	6/25/2003	6/25/2003	372
24	4/30/2003	4/30/2003	430	4/30/2003	4/30/2003	416	7/11/2003	7/11/2003	372
25	4/15/2003	4/22/2003	81	6/11/2003	6/18/2003	0	6/11/2003	6/18/2003	0
26	5/7/2003	5/7/2003	81	7/3/2003	7/3/2003	27	7/3/2003	7/3/2003	33
27	4/15/2003	4/15/2003	200	4/15/2003	4/15/2003	186	6/25/2003	6/25/2003	142
28	4/30/2003	4/30/2003	200	4/30/2003	4/30/2003	186	7/11/2003	7/11/2003	142
29	4/15/2003	4/17/2003	96	6/3/2003	6/5/2003	0	6/3/2003	6/5/2003	0
30	5/2/2003	5/2/2003	96	6/20/2003	6/20/2003	48	6/25/2003	6/25/2003	51
31	4/15/2003	4/22/2003	180	4/15/2003	4/22/2003	166	6/25/2003	7/2/2003	122
32	5/7/2003	5/7/2003	180	5/7/2003	5/7/2003	166	7/18/2003	7/18/2003	122
33	4/15/2003	4/22/2003	272	4/15/2003	4/22/2003	258	6/25/2003	7/2/2003	214
34	5/7/2003	5/7/2003	272	5/7/2003	5/7/2003	258	7/18/2003	7/18/2003	214
35	4/15/2003	4/15/2003	459	4/15/2003	4/15/2003	445	6/25/2003	6/25/2003	401
36	4/30/2003	4/30/2003	459	4/30/2003	4/30/2003	445	7/11/2003	7/11/2003	401
37	4/15/2003	4/15/2003	295	4/15/2003	4/15/2003	281	6/25/2003	6/25/2003	237
38	4/30/2003	4/30/2003	295	4/30/2003	4/30/2003	281	7/11/2003	7/11/2003	237
39	4/15/2003	4/22/2003	411	4/15/2003	4/22/2003	397	6/25/2003	7/2/2003	353
40	5/21/2003	5/21/2003	411	5/21/2003	5/21/2003	397	8/1/2003	8/1/2003	353
41	4/15/2003	4/15/2003	292	4/15/2003	4/15/2003	278	6/25/2003	6/25/2003	234
42	4/30/2003	4/30/2003	292	4/30/2003	4/30/2003	278	7/11/2003	7/11/2003	234
43	4/15/2003	4/15/2003	369	4/15/2003	4/15/2003	355	6/25/2003	6/25/2003	311
44	4/30/2003	4/30/2003	369	4/30/2003	4/30/2003	355	7/11/2003	7/11/2003	311
45	4/15/2003	4/15/2003	450	4/15/2003	4/15/2003	436	6/25/2003	6/25/2003	392
46	4/30/2003	4/30/2003	450	4/30/2003	4/30/2003	436	7/11/2003	7/11/2003	392
47	4/15/2003	4/15/2003	243	4/15/2003	4/15/2003	229	6/25/2003	6/25/2003	185
48	4/30/2003	4/30/2003	243	4/30/2003	4/30/2003	229	7/11/2003	7/11/2003	185
49	4/15/2003	4/15/2003	144	4/15/2003	4/15/2003	130	6/25/2003	6/25/2003	86
50	4/15/2003	4/15/2003	426	4/15/2003	4/15/2003	412	6/25/2003	6/25/2003	368

Table B-1: Continued [pg. 2 of 20]

ID	As-Planned Schedule			20-Jun-03			June 24, 2003 (Rescheduled)		
	Start	Finish	TF	Start	Finish	TF	Start	Finish	TF
51	4/30/2003	4/30/2003	426	4/30/2003	4/30/2003	412	7/11/2003	7/11/2003	368
52	4/15/2003	4/15/2003	416	6/16/2003	6/16/2003	359	6/16/2003	6/25/2003	358
53	4/30/2003	4/30/2003	416	7/1/2003	7/1/2003	359	7/11/2003	7/11/2003	358
54	4/15/2003	4/15/2003	298	4/15/2003	4/15/2003	284	6/25/2003	6/25/2003	240
55	5/29/2003	5/29/2003	298	5/29/2003	5/29/2003	284	8/8/2003	8/8/2003	240
56	4/15/2003	4/15/2003	414	4/15/2003	4/15/2003	400	6/25/2003	6/25/2003	356
57	4/30/2003	4/30/2003	414	4/30/2003	4/30/2003	400	7/11/2003	7/11/2003	356
58	4/15/2003	4/25/2003	406	5/7/2003	5/19/2003	0	5/7/2003	5/19/2003	0
59	5/12/2003	5/12/2003	406	6/4/2003	6/4/2003	376	6/25/2003	6/25/2003	367
60	4/15/2003	4/15/2003	416	4/15/2003	4/15/2003	402	6/25/2003	6/25/2003	358
61	4/30/2003	4/30/2003	416	4/30/2003	4/30/2003	402	7/11/2003	7/11/2003	358
62	4/15/2003	4/15/2003	288	4/15/2003	4/15/2003	274	6/25/2003	6/25/2003	230
63	4/30/2003	4/30/2003	288	4/30/2003	4/30/2003	274	7/11/2003	7/11/2003	230
64	4/15/2003	4/15/2003	141	4/15/2003	4/15/2003	127	6/25/2003	6/25/2003	83
65	4/30/2003	4/30/2003	141	4/30/2003	4/30/2003	127	7/11/2003	7/11/2003	83
66	4/15/2003	4/15/2003	431	4/15/2003	4/15/2003	417	6/25/2003	6/25/2003	373
67	4/30/2003	4/30/2003	431	4/30/2003	4/30/2003	417	7/11/2003	7/11/2003	373
68	4/15/2003	4/15/2003	434	4/15/2003	4/15/2003	420	6/25/2003	6/25/2003	376
69	4/30/2003	4/30/2003	434	4/30/2003	4/30/2003	420	7/11/2003	7/11/2003	376
70	4/15/2003	4/15/2003	302	4/15/2003	4/15/2003	288	6/25/2003	6/25/2003	244
71	4/30/2003	4/30/2003	302	4/30/2003	4/30/2003	288	7/11/2003	7/11/2003	244
72	4/15/2003	4/15/2003	404	4/15/2003	4/15/2003	390	6/25/2003	6/25/2003	346
73	4/30/2003	4/30/2003	404	4/30/2003	4/30/2003	390	7/11/2003	7/11/2003	346
74	4/15/2003	4/15/2003	424	4/15/2003	4/15/2003	410	6/25/2003	6/25/2003	366
75	4/30/2003	4/30/2003	424	4/30/2003	4/30/2003	410	7/11/2003	7/11/2003	366
76	4/15/2003	4/15/2003	355	4/15/2003	4/15/2003	341	6/25/2003	6/25/2003	297
77	4/30/2003	4/30/2003	355	4/30/2003	4/30/2003	341	7/11/2003	7/11/2003	297
78	4/16/2003	5/19/2003	0	4/22/2003	5/28/2003	0	4/22/2003	5/28/2003	0
79	4/16/2003	4/16/2003	0	4/22/2003	4/22/2003	0	4/22/2003	4/22/2003	0
80	4/17/2003	5/2/2003	0	4/23/2003	5/8/2003	0	4/23/2003	5/8/2003	0
81	4/17/2003	4/17/2003	22	5/13/2003	5/13/2003	0	5/13/2003	5/13/2003	0
82	4/18/2003	4/21/2003	22	5/6/2003	5/7/2003	0	5/6/2003	5/7/2003	0
83	5/5/2003	5/19/2003	287	5/12/2003	5/27/2003	0	5/12/2003	5/27/2003	0
84	5/19/2003	5/19/2003	287	5/27/2003	5/28/2003	0	5/27/2003	5/28/2003	0
85	4/17/2003	5/14/2003	8	4/23/2003	5/8/2003	0	4/23/2003	5/8/2003	0
86	4/17/2003	4/18/2003	26	4/23/2003	4/24/2003	0	4/23/2003	4/24/2003	0
87	5/5/2003	5/14/2003	8	4/29/2003	5/8/2003	0	4/29/2003	5/8/2003	0
88	4/22/2003	4/24/2003	22	5/6/2003	5/8/2003	0	5/6/2003	5/8/2003	0
89	5/5/2003	7/29/2003	0	4/25/2003	8/7/2003	435	4/25/2003	8/26/2003	428
90	5/5/2003	5/9/2003	0	4/30/2003	5/6/2003	500	4/30/2003	7/1/2003	467
91	5/12/2003	5/27/2003	0	4/25/2003	5/9/2003	0	4/25/2003	5/9/2003	0
92	5/27/2003	5/27/2003	0	4/25/2003	5/13/2003	0	4/25/2003	5/13/2003	0
93	5/28/2003	6/9/2003	0	6/6/2003	6/18/2003	-12	6/6/2003	7/8/2003	207
94	6/10/2003	6/12/2003	241	6/19/2003	6/23/2003	220	7/9/2003	7/11/2003	213
95	6/13/2003	6/17/2003	241	6/24/2003	6/26/2003	220	7/14/2003	7/16/2003	213
96	6/18/2003	7/16/2003	241	6/27/2003	7/25/2003	220	7/17/2003	8/13/2003	213
97	7/17/2003	7/23/2003	241	7/28/2003	8/1/2003	220	8/14/2003	8/20/2003	213
98	7/24/2003	7/29/2003	241	8/4/2003	8/7/2003	220	8/21/2003	8/26/2003	213
99	6/18/2003	6/20/2003	242	6/27/2003	7/1/2003	221	7/17/2003	7/21/2003	214
100	6/23/2003	6/25/2003	242	7/2/2003	7/7/2003	221	7/22/2003	7/24/2003	214

Table B-1: Continued [pg. 3 of 20]

ID	As-Planned Schedule			20-Jun-03			June 24, 2003 (Rescheduled)		
	Start	Finish	TF	Start	Finish	TF	Start	Finish	TF
101	6/26/2003	7/17/2003	242	7/8/2003	7/28/2003	221	7/25/2003	8/14/2003	214
102	6/10/2003	6/25/2003	0	6/19/2003	7/7/2003	-12	7/9/2003	7/24/2003	207
103	7/18/2003	7/28/2003	242	7/29/2003	8/6/2003	221	8/15/2003	8/25/2003	214
104	6/10/2003	7/31/2003	273	6/19/2003	8/11/2003	252	7/9/2003	8/28/2003	245
105	6/10/2003	6/10/2003	273	6/19/2003	6/19/2003	252	7/9/2003	7/9/2003	245
106	6/11/2003	6/11/2003	273	6/20/2003	6/20/2003	252	7/10/2003	7/10/2003	245
107	6/12/2003	6/13/2003	273	6/23/2003	6/24/2003	252	7/11/2003	7/14/2003	245
108	6/16/2003	6/18/2003	273	6/25/2003	6/27/2003	252	7/15/2003	7/17/2003	245
109	6/19/2003	6/19/2003	273	6/30/2003	6/30/2003	252	7/18/2003	7/18/2003	245
110	6/20/2003	6/20/2003	273	7/1/2003	7/1/2003	252	7/21/2003	7/21/2003	245
111	6/23/2003	6/23/2003	273	7/2/2003	7/2/2003	252	7/22/2003	7/22/2003	245
112	7/29/2003	7/31/2003	276	8/7/2003	8/11/2003	255	8/26/2003	8/28/2003	248
113	6/13/2003	7/9/2003	0	6/6/2003	7/1/2003	226	6/6/2003	7/21/2003	219
114	6/13/2003	6/13/2003	0	6/6/2003	6/6/2003	226	6/6/2003	6/25/2003	219
115	6/16/2003	6/27/2003	0	6/9/2003	6/20/2003	226	6/26/2003	7/10/2003	219
116	6/30/2003	7/9/2003	0	6/23/2003	7/1/2003	226	7/11/2003	7/21/2003	219
117	7/10/2003	8/15/2003	235	7/2/2003	8/18/2003	220	7/22/2003	9/5/2003	213
118	7/10/2003	7/30/2003	235	7/2/2003	7/23/2003	226	7/22/2003	8/11/2003	219
119	7/31/2003	8/6/2003	235	7/24/2003	7/30/2003	226	8/12/2003	8/18/2003	219
120	8/7/2003	8/15/2003	235	8/8/2003	8/18/2003	220	8/27/2003	9/5/2003	213
121	8/7/2003	2/2/2004	242	7/31/2003	2/3/2004	233	8/19/2003	2/20/2004	226
122	8/7/2003	8/13/2003	373	7/31/2003	8/6/2003	364	8/19/2003	8/25/2003	357
123	8/18/2003	8/29/2003	235	8/19/2003	9/2/2003	220	9/8/2003	9/19/2003	213
124	9/2/2003	9/11/2003	235	9/3/2003	9/12/2003	220	9/22/2003	10/1/2003	213
125	9/12/2003	10/9/2003	235	9/15/2003	10/10/2003	220	10/2/2003	10/29/2003	213
126	10/10/2003	11/6/2003	235	10/13/2003	11/7/2003	220	10/30/2003	11/26/2003	213
127	11/7/2003	11/20/2003	235	11/10/2003	11/21/2003	220	12/1/2003	12/12/2003	213
128	9/12/2003	9/18/2003	266	9/15/2003	9/19/2003	251	10/2/2003	10/8/2003	244
129	10/10/2003	10/22/2003	251	10/13/2003	10/23/2003	236	10/30/2003	11/11/2003	229
130	10/23/2003	10/28/2003	251	10/24/2003	10/29/2003	236	11/12/2003	11/17/2003	229
131	10/29/2003	11/4/2003	251	10/30/2003	11/5/2003	236	11/18/2003	11/24/2003	229
132	11/21/2003	12/8/2003	235	11/24/2003	12/9/2003	220	12/15/2003	12/31/2003	213
133	12/9/2003	12/16/2003	235	12/10/2003	12/17/2003	220	1/5/2004	1/12/2004	213
134	12/17/2003	12/18/2003	235	12/18/2003	12/19/2003	220	1/13/2004	1/14/2004	213
135	11/5/2003	11/6/2003	381	11/6/2003	11/7/2003	366	11/25/2003	11/26/2003	359
136	12/19/2003	1/7/2004	235	12/22/2003	1/8/2004	220	1/15/2004	1/27/2004	213
137	1/8/2004	1/15/2004	235	1/9/2004	1/16/2004	220	1/28/2004	2/4/2004	213
138	1/16/2004	1/21/2004	235	1/19/2004	1/22/2004	220	2/5/2004	2/10/2004	213
139	1/22/2004	2/2/2004	235	1/23/2004	2/3/2004	220	2/11/2004	2/20/2004	213
140	11/7/2003	8/5/2004	121	11/10/2003	7/16/2004	121	12/1/2003	7/26/2004	121
141	11/7/2003	11/12/2003	272	11/10/2003	11/13/2003	257	12/1/2003	12/4/2003	250
142	11/13/2003	11/17/2003	272	11/14/2003	11/18/2003	257	12/5/2003	12/9/2003	250
143	11/18/2003	12/3/2003	272	11/19/2003	12/4/2003	257	12/10/2003	12/23/2003	250
144	12/4/2003	12/17/2003	272	12/5/2003	12/18/2003	257	12/29/2003	1/13/2004	250
145	12/18/2003	12/31/2003	272	12/19/2003	1/5/2004	257	1/14/2004	1/22/2004	250
146	7/27/2004	8/5/2004	72	7/7/2004	7/16/2004	72	7/15/2004	7/26/2004	72
147	2/3/2004	3/4/2004	235	2/4/2004	3/5/2004	220	2/23/2004	3/24/2004	213
148	2/3/2004	2/12/2004	235	2/4/2004	2/13/2004	220	2/23/2004	3/3/2004	213
149	2/13/2004	2/17/2004	235	2/16/2004	2/18/2004	220	3/4/2004	3/8/2004	213
150	2/18/2004	2/24/2004	235	2/19/2004	2/25/2004	220	3/9/2004	3/15/2004	213

Table B-1: Continued [pg. 4 of 20]

ID	As-Planned Schedule			20-Jun-03			June 24, 2003 (Rescheduled)		
	Start	Finish	TF	Start	Finish	TF	Start	Finish	TF
151	2/25/2004	3/2/2004	235	2/26/2004	3/3/2004	220	3/16/2004	3/22/2004	213
152	3/3/2004	3/4/2004	235	3/4/2004	3/5/2004	220	3/23/2004	3/24/2004	213
153	8/12/2004	10/14/2004	124	7/23/2004	9/24/2004	124	8/2/2004	10/4/2004	124
154	8/12/2004	8/18/2004	124	7/23/2004	7/29/2004	124	8/2/2004	8/6/2004	124
155	8/19/2004	9/1/2004	124	7/30/2004	8/12/2004	124	8/9/2004	8/20/2004	124
156	9/2/2004	9/16/2004	124	8/13/2004	8/26/2004	124	8/23/2004	9/3/2004	124
157	9/17/2004	9/21/2004	124	8/27/2004	8/31/2004	124	9/7/2004	9/9/2004	124
158	9/22/2004	9/23/2004	124	9/1/2004	9/2/2004	124	9/10/2004	9/13/2004	124
159	9/24/2004	9/30/2004	124	9/3/2004	9/10/2004	124	9/14/2004	9/20/2004	124
160	10/1/2004	10/12/2004	124	9/13/2004	9/22/2004	124	9/21/2004	9/30/2004	124
161	10/13/2004	10/14/2004	124	9/23/2004	9/24/2004	124	10/1/2004	10/4/2004	124
162	6/16/2004	8/27/2004	57	5/26/2004	8/9/2004	57	6/4/2004	8/17/2004	57
163	6/16/2004	6/23/2004	57	5/26/2004	6/3/2004	57	6/4/2004	6/11/2004	57
164	6/24/2004	7/9/2004	57	6/4/2004	6/17/2004	57	6/14/2004	6/25/2004	57
165	7/12/2004	7/19/2004	57	6/18/2004	6/25/2004	57	6/28/2004	7/7/2004	57
166	7/20/2004	7/21/2004	57	6/28/2004	6/29/2004	57	7/8/2004	7/9/2004	57
167	7/22/2004	7/28/2004	57	6/30/2004	7/8/2004	57	7/12/2004	7/16/2004	57
168	7/29/2004	8/11/2004	57	7/9/2004	7/22/2004	57	7/19/2004	7/30/2004	57
169	8/12/2004	8/20/2004	57	7/23/2004	8/2/2004	57	8/2/2004	8/10/2004	57
170	8/23/2004	8/24/2004	57	8/3/2004	8/4/2004	57	8/11/2004	8/12/2004	57
171	8/25/2004	8/27/2004	100	8/5/2004	8/9/2004	100	8/13/2004	8/17/2004	100
172	7/22/2004	8/19/2004	188	6/30/2004	7/30/2004	188	7/12/2004	8/9/2004	188
173	7/22/2004	7/26/2004	188	6/30/2004	7/6/2004	188	7/12/2004	7/14/2004	188
174	7/27/2004	7/30/2004	188	7/7/2004	7/12/2004	188	7/15/2004	7/20/2004	188
175	8/2/2004	8/6/2004	188	7/13/2004	7/19/2004	188	7/21/2004	7/27/2004	188
176	8/9/2004	8/11/2004	188	7/20/2004	7/22/2004	188	7/28/2004	7/30/2004	188
177	8/12/2004	8/17/2004	188	7/23/2004	7/28/2004	188	8/2/2004	8/5/2004	188
178	8/18/2004	8/19/2004	188	7/29/2004	7/30/2004	188	8/6/2004	8/9/2004	188
179	8/25/2004	11/3/2004	135	8/5/2004	10/14/2004	135	8/13/2004	10/22/2004	135
180	8/25/2004	8/30/2004	135	8/5/2004	8/10/2004	135	8/13/2004	8/18/2004	135
181	8/31/2004	9/10/2004	135	8/11/2004	8/20/2004	135	8/19/2004	8/30/2004	135
182	9/13/2004	9/22/2004	135	8/23/2004	9/1/2004	135	8/31/2004	9/10/2004	135
183	9/23/2004	9/30/2004	135	9/2/2004	9/10/2004	135	9/13/2004	9/20/2004	135
184	10/1/2004	10/7/2004	135	9/13/2004	9/17/2004	135	9/21/2004	9/27/2004	135
185	10/8/2004	10/14/2004	135	9/20/2004	9/24/2004	135	9/28/2004	10/4/2004	135
186	10/15/2004	10/18/2004	135	9/27/2004	9/28/2004	135	10/5/2004	10/6/2004	135
187	10/19/2004	11/1/2004	135	9/29/2004	10/12/2004	135	10/7/2004	10/20/2004	135
188	11/2/2004	11/3/2004	135	10/13/2004	10/14/2004	135	10/21/2004	10/22/2004	135
189	11/23/2004	3/1/2005	40	11/3/2004	2/9/2005	40	11/11/2004	2/17/2005	40
190	11/23/2004	12/1/2004	40	11/3/2004	11/9/2004	40	11/11/2004	11/17/2004	40
191	12/2/2004	12/3/2004	40	11/10/2004	11/11/2004	40	11/18/2004	11/19/2004	40
192	12/6/2004	12/17/2004	40	11/12/2004	11/29/2004	40	11/22/2004	12/7/2004	40
193	12/20/2004	1/4/2005	40	11/30/2004	12/13/2004	40	12/8/2004	12/21/2004	40
194	1/5/2005	1/11/2005	40	12/14/2004	12/20/2004	40	12/22/2004	12/29/2004	40
195	1/12/2005	1/25/2005	40	12/21/2004	1/5/2005	40	12/30/2004	1/13/2005	40
196	1/26/2005	2/8/2005	40	1/6/2005	1/19/2005	40	1/14/2005	1/27/2005	40
197	2/9/2005	3/1/2005	40	1/20/2005	2/9/2005	40	1/28/2005	2/17/2005	40
198	1/5/2005	3/22/2005	40	12/14/2004	3/2/2005	40	12/22/2004	3/10/2005	40
199	1/5/2005	1/11/2005	65	12/14/2004	12/20/2004	65	12/22/2004	12/29/2004	65
200	1/26/2005	2/8/2005	55	1/6/2005	1/19/2005	55	1/14/2005	1/27/2005	55
201	3/2/2005	3/22/2005	40	2/10/2005	3/2/2005	40	2/18/2005	3/10/2005	40

Table B-1: Continued [pg. 5 of 20]

ID	As-Planned Schedule			20-Jun-03			June 24, 2003 (Rescheduled)		
	Start	Finish	TF	Start	Finish	TF	Start	Finish	TF
202	8/25/2004	2/25/2005	57	8/5/2004	2/7/2005	57	8/13/2004	2/15/2005	57
203	8/25/2004	8/26/2004	57	8/5/2004	8/6/2004	57	8/13/2004	8/16/2004	57
204	8/27/2004	9/2/2004	57	8/9/2004	8/13/2004	57	8/17/2004	8/23/2004	57
205	9/3/2004	9/24/2004	57	8/16/2004	9/3/2004	57	8/24/2004	9/14/2004	57
206	9/27/2004	9/30/2004	57	9/7/2004	9/10/2004	57	9/15/2004	9/20/2004	57
207	10/1/2004	10/14/2004	57	9/13/2004	9/24/2004	57	9/21/2004	10/4/2004	57
208	10/15/2004	10/18/2004	57	9/27/2004	9/28/2004	57	10/5/2004	10/6/2004	57
209	10/19/2004	11/1/2004	57	9/29/2004	10/12/2004	57	10/7/2004	10/20/2004	57
210	11/2/2004	11/8/2004	57	10/13/2004	10/19/2004	57	10/21/2004	10/27/2004	57
211	11/9/2004	11/15/2004	57	10/20/2004	10/26/2004	57	10/28/2004	11/3/2004	57
212	11/16/2004	11/29/2004	57	10/27/2004	11/5/2004	57	11/4/2004	11/15/2004	57
213	11/30/2004	12/13/2004	57	11/8/2004	11/19/2004	57	11/16/2004	12/1/2004	57
214	8/30/2004	9/27/2004	111	8/10/2004	9/7/2004	111	8/18/2004	9/15/2004	111
215	10/15/2004	10/28/2004	77	9/27/2004	10/8/2004	77	10/5/2004	10/18/2004	77
216	10/29/2004	11/4/2004	77	10/11/2004	10/15/2004	77	10/19/2004	10/25/2004	77
217	12/7/2004	12/14/2004	57	11/15/2004	11/22/2004	57	11/23/2004	12/2/2004	57
218	12/15/2004	12/22/2004	57	11/23/2004	12/2/2004	57	12/3/2004	12/10/2004	57
219	12/16/2004	12/22/2004	57	11/24/2004	12/2/2004	57	12/6/2004	12/10/2004	57
220	12/23/2004	1/7/2005	57	12/3/2004	12/16/2004	57	12/13/2004	12/27/2004	57
221	1/10/2005	1/14/2005	57	12/17/2004	12/23/2004	57	12/28/2004	1/4/2005	57
222	1/17/2005	1/20/2005	57	12/27/2004	12/30/2004	57	1/5/2005	1/10/2005	57
223	1/21/2005	1/28/2005	57	1/3/2005	1/10/2005	57	1/11/2005	1/18/2005	57
224	1/31/2005	2/4/2005	57	1/11/2005	1/17/2005	57	1/19/2005	1/25/2005	57
225	12/23/2004	12/29/2004	78	12/3/2004	12/8/2004	78	12/13/2004	12/16/2004	78
226	12/23/2004	1/21/2005	76	12/3/2004	1/3/2005	76	12/13/2004	1/11/2005	76
227	1/24/2005	1/27/2005	76	1/4/2005	1/7/2005	76	1/12/2005	1/17/2005	76
228	2/24/2005	2/25/2005	57	2/4/2005	2/7/2005	57	2/14/2005	2/15/2005	57
229	1/17/2005	2/7/2005	71	12/27/2004	1/18/2005	71	1/5/2005	1/26/2005	71
230	1/17/2005	1/18/2005	71	12/27/2004	12/28/2004	71	1/5/2005	1/6/2005	71
231	1/19/2005	1/21/2005	71	12/29/2004	1/3/2005	71	1/7/2005	1/11/2005	71
232	1/24/2005	1/25/2005	71	1/4/2005	1/5/2005	71	1/12/2005	1/13/2005	71
233	1/26/2005	1/28/2005	71	1/6/2005	1/10/2005	71	1/14/2005	1/18/2005	71
234	1/31/2005	1/31/2005	71	1/11/2005	1/11/2005	71	1/19/2005	1/19/2005	71
235	2/1/2005	2/7/2005	71	1/12/2005	1/18/2005	71	1/20/2005	1/26/2005	71
236	7/8/2003	10/30/2003	0	6/13/2003	10/10/2003	0	6/13/2003	10/20/2003	0
237	7/10/2003	7/10/2003	0	6/13/2003	6/13/2003	0	6/13/2003	6/13/2003	0
238	7/8/2003	8/6/2003	0	6/17/2003	7/17/2003	0	6/17/2003	7/25/2003	0
239	8/1/2003	8/26/2003	0	7/14/2003	8/6/2003	0	7/22/2003	8/14/2003	0
240	8/7/2003	9/2/2003	8	7/18/2003	8/12/2003	8	7/28/2003	8/20/2003	8
241	8/14/2003	9/8/2003	0	7/25/2003	8/18/2003	0	8/4/2003	8/26/2003	0
242	8/26/2003	9/5/2003	0	8/6/2003	8/15/2003	0	8/14/2003	8/25/2003	0
243	9/8/2003	9/9/2003	0	8/18/2003	8/19/2003	0	8/26/2003	8/27/2003	0
244	9/3/2003	9/10/2003	1	8/13/2003	8/20/2003	1	8/21/2003	8/28/2003	1
245	9/10/2003	9/16/2003	0	8/20/2003	8/26/2003	0	8/28/2003	9/4/2003	0
246	9/11/2003	9/26/2003	0	8/21/2003	9/8/2003	0	8/29/2003	9/16/2003	0
247	9/25/2003	9/30/2003	0	9/5/2003	9/10/2003	0	9/15/2003	9/18/2003	0
248	9/30/2003	10/3/2003	0	9/10/2003	9/15/2003	0	9/18/2003	9/23/2003	0
249	10/6/2003	10/6/2003	0	9/16/2003	9/16/2003	0	9/24/2003	9/24/2003	0
250	10/7/2003	10/8/2003	0	9/17/2003	9/18/2003	0	9/25/2003	9/26/2003	0

Table B-1: Continued [pg. 6 of 20]

ID	As-Planned Schedule			20-Jun-03			June 24, 2003 (Rescheduled)		
	Start	Finish	TF	Start	Finish	TF	Start	Finish	TF
251	10/9/2003	10/20/2003	0	9/19/2003	9/30/2003	0	9/29/2003	10/8/2003	0
252	10/9/2003	10/14/2003	1	9/19/2003	9/24/2003	1	9/29/2003	10/2/2003	1
253	10/14/2003	10/30/2003	0	9/24/2003	10/10/2003	0	10/2/2003	10/20/2003	0
254	7/11/2003	11/12/2003	6	6/16/2003	10/23/2003	6	6/25/2003	10/31/2003	6
255	7/11/2003	7/14/2003	37	6/16/2003	6/17/2003	41	6/25/2003	6/26/2003	40
256	8/14/2003	8/20/2003	15	7/25/2003	7/31/2003	15	8/4/2003	8/8/2003	15
257	8/15/2003	8/26/2003	19	7/28/2003	8/6/2003	19	8/5/2003	8/14/2003	19
258	9/3/2003	9/8/2003	8	8/13/2003	8/18/2003	8	8/21/2003	8/26/2003	8
259	8/15/2003	8/26/2003	19	7/28/2003	8/6/2003	19	8/5/2003	8/14/2003	19
260	9/9/2003	9/22/2003	8	8/19/2003	9/2/2003	8	8/27/2003	9/10/2003	8
261	9/23/2003	9/24/2003	8	9/3/2003	9/4/2003	8	9/11/2003	9/12/2003	8
262	8/27/2003	9/2/2003	24	8/7/2003	8/12/2003	24	8/15/2003	8/20/2003	24
263	9/25/2003	9/29/2003	8	9/5/2003	9/9/2003	8	9/15/2003	9/17/2003	8
264	9/29/2003	10/20/2003	6	9/9/2003	9/30/2003	6	9/17/2003	10/8/2003	6
265	10/17/2003	10/20/2003	6	9/29/2003	9/30/2003	6	10/7/2003	10/8/2003	6
266	10/21/2003	10/23/2003	6	10/1/2003	10/3/2003	6	10/9/2003	10/13/2003	6
267	10/24/2003	10/24/2003	6	10/6/2003	10/6/2003	6	10/14/2003	10/14/2003	6
268	10/27/2003	10/27/2003	6	10/7/2003	10/7/2003	6	10/15/2003	10/15/2003	6
269	10/28/2003	11/3/2003	9	10/8/2003	10/14/2003	9	10/16/2003	10/22/2003	9
270	10/28/2003	10/30/2003	6	10/8/2003	10/10/2003	6	10/16/2003	10/20/2003	6
271	10/31/2003	11/12/2003	6	10/13/2003	10/23/2003	6	10/21/2003	10/31/2003	6
272	10/31/2003	12/2/2003	0	10/13/2003	11/10/2003	0	10/21/2003	11/18/2003	0
273	10/31/2003	11/6/2003	0	10/13/2003	10/17/2003	0	10/21/2003	10/27/2003	0
274	11/7/2003	11/12/2003	0	10/20/2003	10/23/2003	0	10/28/2003	10/31/2003	0
275	11/10/2003	12/2/2003	0	10/21/2003	11/10/2003	0	10/29/2003	11/18/2003	0
276	11/14/2003	11/25/2003	3	10/27/2003	11/5/2003	3	11/4/2003	11/13/2003	3
277	11/20/2003	11/25/2003	3	10/31/2003	11/5/2003	3	11/10/2003	11/13/2003	3
278	11/13/2003	12/8/2003	6	10/24/2003	11/14/2003	6	11/3/2003	11/24/2003	6
279	11/13/2003	11/17/2003	6	10/24/2003	10/28/2003	6	11/3/2003	11/5/2003	6
280	11/18/2003	11/20/2003	6	10/29/2003	10/31/2003	6	11/6/2003	11/10/2003	6
281	11/21/2003	12/8/2003	6	11/3/2003	11/14/2003	6	11/11/2003	11/24/2003	6
282	11/24/2003	12/3/2003	9	11/4/2003	11/11/2003	9	11/12/2003	11/19/2003	9
283	12/1/2003	12/3/2003	9	11/7/2003	11/11/2003	9	11/17/2003	11/19/2003	9
284	12/3/2003	1/7/2004	0	11/11/2003	12/11/2003	0	11/19/2003	12/19/2003	0
285	12/3/2003	12/9/2003	0	11/11/2003	11/17/2003	0	11/19/2003	11/25/2003	0
286	12/10/2003	12/15/2003	0	11/18/2003	11/21/2003	0	11/26/2003	12/3/2003	0
287	12/11/2003	1/7/2004	0	11/19/2003	12/11/2003	0	12/1/2003	12/19/2003	0
288	12/17/2003	12/31/2003	3	11/25/2003	12/8/2003	3	12/5/2003	12/16/2003	3
289	12/23/2003	12/31/2003	3	12/3/2003	12/8/2003	3	12/11/2003	12/16/2003	3
290	12/10/2003	1/7/2004	5	11/18/2003	12/11/2003	5	11/26/2003	12/19/2003	5
291	12/10/2003	12/12/2003	5	11/18/2003	11/20/2003	5	11/26/2003	12/2/2003	5
292	12/15/2003	12/17/2003	5	11/21/2003	11/25/2003	5	12/3/2003	12/5/2003	5
293	12/18/2003	1/7/2004	5	11/26/2003	12/11/2003	5	12/8/2003	12/19/2003	5
294	12/19/2003	12/31/2003	8	12/1/2003	12/8/2003	8	12/9/2003	12/16/2003	8
295	12/29/2003	12/31/2003	8	12/4/2003	12/8/2003	8	12/12/2003	12/16/2003	8
296	1/8/2004	2/5/2004	0	12/12/2003	1/16/2004	0	12/22/2003	1/26/2004	0
297	1/8/2004	1/14/2004	0	12/12/2003	12/18/2003	0	12/22/2003	12/31/2003	0
298	1/15/2004	1/20/2004	3	12/19/2003	12/29/2003	3	1/5/2004	1/8/2004	3
299	1/16/2004	2/5/2004	3	12/22/2003	1/16/2004	3	1/6/2004	1/26/2004	3
300	1/22/2004	2/2/2004	3	12/31/2003	1/13/2004	3	1/12/2004	1/21/2004	3
301	1/28/2004	2/2/2004	3	1/8/2004	1/13/2004	3	1/16/2004	1/21/2004	3

Table B-1: Continued [pg. 7 of 20]

ID	As-Planned Schedule			20-Jun-03			June 24, 2003 (Rescheduled)		
	Start	Finish	TF	Start	Finish	TF	Start	Finish	TF
302	1/15/2004	2/5/2004	0	12/19/2003	1/16/2004	0	1/5/2004	1/26/2004	0
303	1/15/2004	1/19/2004	0	12/19/2003	12/23/2003	0	1/5/2004	1/7/2004	0
304	1/20/2004	1/22/2004	0	12/29/2003	12/31/2003	0	1/8/2004	1/12/2004	0
305	1/23/2004	2/5/2004	0	1/5/2004	1/16/2004	0	1/13/2004	1/26/2004	0
306	1/26/2004	2/2/2004	3	1/6/2004	1/13/2004	3	1/14/2004	1/21/2004	3
307	1/29/2004	2/2/2004	3	1/9/2004	1/13/2004	3	1/19/2004	1/21/2004	3
308	1/20/2004	1/29/2004	25	12/29/2003	1/9/2004	25	1/8/2004	1/19/2004	25
309	2/6/2004	3/11/2004	0	1/19/2004	2/20/2004	0	1/27/2004	3/1/2004	0
310	2/6/2004	2/19/2004	0	1/19/2004	1/30/2004	0	1/27/2004	2/9/2004	0
311	2/20/2004	2/24/2004	0	2/2/2004	2/4/2004	0	2/10/2004	2/12/2004	0
312	2/25/2004	3/1/2004	0	2/5/2004	2/10/2004	0	2/13/2004	2/18/2004	0
313	3/2/2004	3/11/2004	0	2/11/2004	2/20/2004	0	2/19/2004	3/1/2004	0
314	3/12/2004	5/27/2004	0	2/23/2004	5/7/2004	0	3/2/2004	5/17/2004	0
315	3/12/2004	3/17/2004	0	2/23/2004	2/26/2004	0	3/2/2004	3/5/2004	0
316	3/18/2004	3/24/2004	0	2/27/2004	3/4/2004	0	3/8/2004	3/12/2004	0
317	3/25/2004	3/31/2004	5	3/5/2004	3/11/2004	5	3/15/2004	3/19/2004	5
318	4/1/2004	4/7/2004	5	3/12/2004	3/18/2004	5	3/22/2004	3/26/2004	5
319	4/8/2004	4/15/2004	250	3/19/2004	3/26/2004	250	3/29/2004	4/5/2004	250
320	5/14/2004	5/27/2004	240	4/26/2004	5/7/2004	240	5/4/2004	5/17/2004	240
321	1/30/2004	5/13/2004	25	1/12/2004	4/23/2004	25	1/20/2004	5/3/2004	25
322	1/30/2004	2/12/2004	25	1/12/2004	1/23/2004	25	1/20/2004	2/2/2004	25
323	2/13/2004	2/18/2004	25	1/26/2004	1/29/2004	25	2/3/2004	2/6/2004	25
324	3/25/2004	4/7/2004	0	3/5/2004	3/18/2004	0	3/15/2004	3/26/2004	0
325	4/8/2004	4/14/2004	0	3/19/2004	3/25/2004	0	3/29/2004	4/2/2004	0
326	4/15/2004	4/21/2004	0	3/26/2004	4/1/2004	0	4/5/2004	4/9/2004	0
327	4/22/2004	4/29/2004	240	4/2/2004	4/9/2004	240	4/12/2004	4/19/2004	240
328	4/30/2004	5/13/2004	240	4/12/2004	4/23/2004	240	4/20/2004	5/3/2004	240
329	2/6/2004	7/26/2004	40	1/19/2004	7/6/2004	40	1/27/2004	7/14/2004	40
330	2/6/2004	2/19/2004	40	1/19/2004	1/30/2004	40	1/27/2004	2/9/2004	40
331	4/12/2004	4/21/2004	46	3/23/2004	4/1/2004	46	3/31/2004	4/9/2004	46
332	2/12/2004	3/10/2004	40	1/23/2004	2/19/2004	40	2/2/2004	2/27/2004	40
333	4/30/2004	5/27/2004	40	4/12/2004	5/7/2004	40	4/20/2004	5/17/2004	40
334	2/20/2004	3/9/2004	134	2/2/2004	2/18/2004	134	2/10/2004	2/26/2004	134
335	4/22/2004	5/7/2004	103	4/2/2004	4/19/2004	103	4/12/2004	4/27/2004	103
336	5/28/2004	6/11/2004	93	5/10/2004	5/21/2004	93	5/18/2004	6/1/2004	93
337	5/28/2004	6/2/2004	100	5/10/2004	5/12/2004	100	5/18/2004	5/20/2004	100
338	6/2/2004	6/22/2004	72	5/12/2004	6/2/2004	72	5/20/2004	6/10/2004	72
339	6/23/2004	6/30/2004	72	6/3/2004	6/10/2004	72	6/11/2004	6/18/2004	72
340	7/1/2004	7/14/2004	72	6/11/2004	6/22/2004	72	6/21/2004	6/30/2004	72
341	7/15/2004	7/19/2004	72	6/23/2004	6/25/2004	72	7/1/2004	7/7/2004	72
342	7/20/2004	7/26/2004	72	6/28/2004	7/6/2004	72	7/8/2004	7/14/2004	72
343	2/20/2004	8/4/2004	45	2/2/2004	7/15/2004	45	2/10/2004	7/23/2004	45
344	2/20/2004	3/16/2004	45	2/2/2004	2/25/2004	45	2/10/2004	3/4/2004	45
345	3/17/2004	4/9/2004	46	2/26/2004	3/22/2004	46	3/5/2004	3/30/2004	46
346	3/11/2004	4/7/2004	40	2/20/2004	3/18/2004	40	3/1/2004	3/26/2004	40
347	4/8/2004	5/5/2004	40	3/19/2004	4/15/2004	40	3/29/2004	4/23/2004	40
348	3/17/2004	4/2/2004	256	2/26/2004	3/15/2004	256	3/5/2004	3/23/2004	256
349	4/12/2004	4/27/2004	251	3/23/2004	4/7/2004	251	3/31/2004	4/15/2004	251
350	5/6/2004	5/19/2004	235	4/16/2004	4/29/2004	235	4/26/2004	5/7/2004	235

Table B-1: Continued [pg. 8 of 20]

ID	As-Planned Schedule			20-Jun-03			June 24, 2003 (Rescheduled)		
	Start	Finish	TF	Start	Finish	TF	Start	Finish	TF
351	5/6/2004	5/6/2004	244	4/16/2004	4/16/2004	244	4/26/2004	4/26/2004	244
352	5/6/2004	5/21/2004	57	4/16/2004	5/3/2004	57	4/26/2004	5/11/2004	57
353	5/24/2004	6/1/2004	57	5/4/2004	5/11/2004	57	5/12/2004	5/19/2004	57
354	6/2/2004	6/15/2004	57	5/12/2004	5/25/2004	57	5/20/2004	6/3/2004	57
355	7/20/2004	7/23/2004	195	6/28/2004	7/1/2004	195	7/8/2004	7/13/2004	195
356	7/27/2004	8/4/2004	194	7/7/2004	7/15/2004	194	7/15/2004	7/23/2004	194
357	4/22/2004	10/13/2004	0	4/2/2004	9/23/2004	0	4/12/2004	10/1/2004	0
358	4/22/2004	4/27/2004	0	4/2/2004	4/7/2004	0	4/12/2004	4/15/2004	0
359	4/28/2004	5/3/2004	0	4/8/2004	4/13/2004	0	4/16/2004	4/21/2004	0
360	4/22/2004	5/5/2004	113	4/2/2004	4/15/2004	113	4/12/2004	4/23/2004	113
361	5/6/2004	5/19/2004	113	4/16/2004	4/29/2004	113	4/26/2004	5/7/2004	113
362	5/20/2004	5/25/2004	113	4/30/2004	5/5/2004	113	5/10/2004	5/13/2004	113
363	5/4/2004	5/7/2004	0	4/14/2004	4/19/2004	0	4/22/2004	4/27/2004	0
364	5/6/2004	5/19/2004	0	4/16/2004	4/29/2004	0	4/26/2004	5/7/2004	0
365	5/13/2004	6/10/2004	68	4/23/2004	5/20/2004	68	5/3/2004	5/28/2004	68
366	5/13/2004	6/10/2004	68	4/23/2004	5/20/2004	68	5/3/2004	5/28/2004	68
367	5/14/2004	6/3/2004	0	4/26/2004	5/13/2004	0	5/4/2004	5/21/2004	0
368	5/20/2004	6/7/2004	83	4/30/2004	5/17/2004	83	5/10/2004	5/25/2004	83
369	5/13/2004	6/8/2004	82	4/23/2004	5/18/2004	82	5/3/2004	5/26/2004	82
370	6/11/2004	6/28/2004	68	5/21/2004	6/8/2004	68	6/1/2004	6/16/2004	68
371	6/11/2004	6/28/2004	68	5/21/2004	6/8/2004	68	6/1/2004	6/16/2004	68
372	6/4/2004	6/15/2004	77	5/14/2004	5/25/2004	77	5/24/2004	6/3/2004	77
373	5/20/2004	5/25/2004	80	4/30/2004	5/5/2004	80	5/10/2004	5/13/2004	80
374	5/26/2004	6/7/2004	80	5/6/2004	5/17/2004	80	5/14/2004	5/25/2004	80
375	6/8/2004	6/15/2004	80	5/18/2004	5/25/2004	80	5/26/2004	6/3/2004	80
376	6/9/2004	6/22/2004	176	5/19/2004	6/2/2004	176	5/27/2004	6/10/2004	176
377	6/29/2004	7/13/2004	68	6/9/2004	6/21/2004	68	6/17/2004	6/29/2004	68
378	7/7/2004	8/3/2004	72	6/15/2004	7/14/2004	72	6/23/2004	7/22/2004	72
379	7/14/2004	7/20/2004	68	6/22/2004	6/28/2004	68	6/30/2004	7/8/2004	68
380	7/21/2004	8/5/2004	68	6/29/2004	7/16/2004	68	7/9/2004	7/26/2004	68
381	8/2/2004	8/13/2004	68	7/13/2004	7/26/2004	68	7/21/2004	8/3/2004	68
382	8/4/2004	8/11/2004	72	7/15/2004	7/22/2004	72	7/23/2004	7/30/2004	72
383	8/16/2004	8/18/2004	68	7/27/2004	7/29/2004	68	8/4/2004	8/6/2004	68
384	8/19/2004	8/25/2004	68	7/30/2004	8/5/2004	68	8/9/2004	8/13/2004	68
385	7/14/2004	7/27/2004	171	6/22/2004	7/7/2004	171	6/30/2004	7/15/2004	171
386	6/23/2004	6/30/2004	176	6/3/2004	6/10/2004	176	6/11/2004	6/18/2004	176
387	8/12/2004	8/19/2004	148	7/23/2004	7/30/2004	148	8/2/2004	8/9/2004	148
388	8/20/2004	8/27/2004	148	8/2/2004	8/9/2004	148	8/10/2004	8/17/2004	148
389	8/30/2004	9/13/2004	148	8/10/2004	8/23/2004	148	8/18/2004	8/31/2004	148
390	8/19/2004	8/24/2004	69	7/30/2004	8/4/2004	69	8/9/2004	8/12/2004	69
391	8/12/2004	8/23/2004	72	7/23/2004	8/3/2004	72	8/2/2004	8/11/2004	72
392	9/14/2004	9/17/2004	148	8/24/2004	8/27/2004	148	9/1/2004	9/7/2004	148
393	8/19/2004	8/24/2004	72	7/30/2004	8/4/2004	72	8/9/2004	8/12/2004	72
394	8/20/2004	9/1/2004	159	8/2/2004	8/12/2004	159	8/10/2004	8/20/2004	159
395	8/24/2004	8/26/2004	163	8/4/2004	8/6/2004	163	8/12/2004	8/16/2004	163
396	8/24/2004	9/7/2004	156	8/4/2004	8/17/2004	156	8/12/2004	8/25/2004	156
397	8/24/2004	8/24/2004	72	8/4/2004	8/4/2004	72	8/12/2004	8/12/2004	72
398	8/26/2004	8/30/2004	68	8/6/2004	8/10/2004	68	8/16/2004	8/18/2004	68
399	8/31/2004	9/10/2004	68	8/11/2004	8/20/2004	68	8/19/2004	8/30/2004	68
400	9/13/2004	9/14/2004	136	8/23/2004	8/24/2004	136	8/31/2004	9/1/2004	136

Table B-1: Continued [pg. 9 of 20]

ID	As-Planned Schedule			20-Jun-03			June 24, 2003 (Rescheduled)		
	Start	Finish	TF	Start	Finish	TF	Start	Finish	TF
401	9/9/2004	9/22/2004	68	8/19/2004	9/1/2004	68	8/27/2004	9/10/2004	68
402	9/23/2004	10/6/2004	135	9/2/2004	9/16/2004	135	9/13/2004	9/24/2004	135
403	9/23/2004	9/30/2004	139	9/2/2004	9/10/2004	139	9/13/2004	9/20/2004	139
404	10/7/2004	10/13/2004	135	9/17/2004	9/23/2004	135	9/27/2004	10/1/2004	135
405	4/28/2004	10/27/2004	7	4/8/2004	10/7/2004	7	4/16/2004	10/15/2004	7
406	4/28/2004	5/3/2004	7	4/8/2004	4/13/2004	7	4/16/2004	4/21/2004	7
407	5/4/2004	5/7/2004	7	4/14/2004	4/19/2004	7	4/22/2004	4/27/2004	7
408	5/10/2004	5/13/2004	7	4/20/2004	4/23/2004	7	4/28/2004	5/3/2004	7
409	5/14/2004	5/27/2004	7	4/26/2004	5/7/2004	7	5/4/2004	5/17/2004	7
410	5/21/2004	6/11/2004	79	5/3/2004	5/21/2004	79	5/11/2004	6/1/2004	79
411	5/21/2004	6/11/2004	79	5/3/2004	5/21/2004	79	5/11/2004	6/1/2004	79
412	6/4/2004	6/17/2004	0	5/14/2004	5/27/2004	0	5/24/2004	6/7/2004	0
413	5/25/2004	6/10/2004	90	5/5/2004	5/20/2004	90	5/13/2004	5/28/2004	90
414	5/21/2004	6/11/2004	89	5/3/2004	5/21/2004	89	5/11/2004	6/1/2004	89
415	6/14/2004	6/25/2004	79	5/24/2004	6/7/2004	79	6/2/2004	6/15/2004	79
416	6/14/2004	6/25/2004	79	5/24/2004	6/7/2004	79	6/2/2004	6/15/2004	79
417	6/18/2004	6/29/2004	77	5/28/2004	6/9/2004	77	6/8/2004	6/17/2004	77
418	5/28/2004	6/3/2004	84	5/10/2004	5/13/2004	84	5/18/2004	5/21/2004	84
419	6/4/2004	6/15/2004	84	5/14/2004	5/25/2004	84	5/24/2004	6/3/2004	84
420	6/16/2004	6/23/2004	84	5/26/2004	6/3/2004	84	6/4/2004	6/11/2004	84
421	6/30/2004	7/14/2004	77	6/10/2004	6/22/2004	77	6/18/2004	6/30/2004	77
422	6/14/2004	6/25/2004	178	5/24/2004	6/7/2004	178	6/2/2004	6/15/2004	178
423	7/8/2004	8/4/2004	81	6/16/2004	7/15/2004	81	6/24/2004	7/23/2004	81
424	7/15/2004	7/21/2004	77	6/23/2004	6/29/2004	77	7/1/2004	7/9/2004	77
425	7/22/2004	8/6/2004	77	6/30/2004	7/19/2004	77	7/12/2004	7/27/2004	77
426	8/3/2004	8/16/2004	77	7/14/2004	7/27/2004	77	7/22/2004	8/4/2004	77
427	8/5/2004	8/12/2004	81	7/16/2004	7/23/2004	81	7/26/2004	8/2/2004	81
428	8/17/2004	8/19/2004	77	7/28/2004	7/30/2004	77	8/5/2004	8/9/2004	77
429	8/20/2004	8/26/2004	77	8/2/2004	8/6/2004	77	8/10/2004	8/16/2004	77
430	7/15/2004	7/28/2004	175	6/23/2004	7/8/2004	175	7/1/2004	7/16/2004	175
431	6/28/2004	7/7/2004	178	6/8/2004	6/15/2004	178	6/16/2004	6/23/2004	178
432	8/13/2004	8/20/2004	152	7/26/2004	8/2/2004	152	8/3/2004	8/10/2004	152
433	8/23/2004	8/30/2004	152	8/3/2004	8/10/2004	152	8/11/2004	8/18/2004	152
434	8/31/2004	9/14/2004	152	8/11/2004	8/24/2004	152	8/19/2004	9/1/2004	152
435	8/20/2004	8/25/2004	78	8/2/2004	8/5/2004	78	8/10/2004	8/13/2004	78
436	8/13/2004	8/24/2004	81	7/26/2004	8/4/2004	81	8/3/2004	8/12/2004	81
437	9/15/2004	9/20/2004	152	8/25/2004	8/30/2004	152	9/2/2004	9/8/2004	152
438	8/20/2004	8/25/2004	78	8/2/2004	8/5/2004	78	8/10/2004	8/13/2004	78
439	8/23/2004	9/2/2004	163	8/3/2004	8/13/2004	163	8/11/2004	8/23/2004	163
440	8/25/2004	8/27/2004	167	8/5/2004	8/9/2004	167	8/13/2004	8/17/2004	167
441	8/25/2004	9/8/2004	160	8/5/2004	8/18/2004	160	8/13/2004	8/26/2004	160
442	8/25/2004	8/25/2004	81	8/5/2004	8/5/2004	81	8/13/2004	8/13/2004	81
443	8/27/2004	8/31/2004	77	8/9/2004	8/11/2004	77	8/17/2004	8/19/2004	77
444	9/1/2004	9/13/2004	77	8/12/2004	8/23/2004	77	8/20/2004	8/31/2004	77
445	9/15/2004	9/16/2004	136	8/25/2004	8/26/2004	136	9/2/2004	9/3/2004	136
446	9/23/2004	10/6/2004	68	9/2/2004	9/16/2004	68	9/13/2004	9/24/2004	68
447	10/7/2004	10/20/2004	130	9/17/2004	9/30/2004	130	9/27/2004	10/8/2004	130
448	10/7/2004	10/14/2004	134	9/17/2004	9/24/2004	134	9/27/2004	10/4/2004	134
449	10/21/2004	10/27/2004	130	10/1/2004	10/7/2004	130	10/11/2004	10/15/2004	130

Table B-1: Continued [pg. 10 of 20]

ID	As-Planned Schedule			20-Jun-03			June 24, 2003 (Rescheduled)		
	Start	Finish	TF	Start	Finish	TF	Start	Finish	TF
450	5/4/2004	11/10/2004	10	4/14/2004	10/21/2004	10	4/22/2004	10/29/2004	10
451	5/4/2004	5/7/2004	10	4/14/2004	4/19/2004	10	4/22/2004	4/27/2004	10
452	5/10/2004	5/13/2004	10	4/20/2004	4/23/2004	10	4/28/2004	5/3/2004	10
453	5/14/2004	5/19/2004	10	4/26/2004	4/29/2004	10	5/4/2004	5/7/2004	10
454	5/20/2004	6/3/2004	10	4/30/2004	5/13/2004	10	5/10/2004	5/21/2004	10
455	6/11/2004	7/1/2004	75	5/21/2004	6/11/2004	75	6/1/2004	6/21/2004	75
456	6/11/2004	7/1/2004	75	5/21/2004	6/11/2004	75	6/1/2004	6/21/2004	75
457	6/18/2004	7/1/2004	0	5/28/2004	6/11/2004	0	6/8/2004	6/21/2004	0
458	6/8/2004	6/23/2004	91	5/18/2004	6/3/2004	91	5/26/2004	6/11/2004	91
459	6/9/2004	6/29/2004	84	5/19/2004	6/9/2004	84	5/27/2004	6/17/2004	84
460	7/6/2004	7/19/2004	75	6/14/2004	6/25/2004	75	6/22/2004	7/7/2004	75
461	7/6/2004	7/19/2004	75	6/14/2004	6/25/2004	75	6/22/2004	7/7/2004	75
462	7/6/2004	7/15/2004	77	6/14/2004	6/23/2004	77	6/22/2004	7/1/2004	77
463	6/4/2004	6/9/2004	90	5/14/2004	5/19/2004	90	5/24/2004	5/27/2004	90
464	6/10/2004	6/21/2004	90	5/20/2004	6/1/2004	90	5/28/2004	6/9/2004	90
465	6/22/2004	6/29/2004	90	6/2/2004	6/9/2004	90	6/10/2004	6/17/2004	90
466	6/30/2004	7/15/2004	171	6/10/2004	6/23/2004	171	6/18/2004	7/1/2004	171
467	7/20/2004	7/30/2004	75	6/28/2004	7/12/2004	75	7/8/2004	7/20/2004	75
468	7/26/2004	8/20/2004	79	7/6/2004	8/2/2004	79	7/14/2004	8/10/2004	79
469	8/2/2004	8/6/2004	75	7/13/2004	7/19/2004	75	7/21/2004	7/27/2004	75
470	8/9/2004	8/24/2004	75	7/20/2004	8/4/2004	75	7/28/2004	8/12/2004	75
471	8/19/2004	9/1/2004	75	7/30/2004	8/12/2004	75	8/9/2004	8/20/2004	75
472	8/23/2004	8/30/2004	79	8/3/2004	8/10/2004	79	8/11/2004	8/18/2004	79
473	9/2/2004	9/7/2004	75	8/13/2004	8/17/2004	75	8/23/2004	8/25/2004	75
474	9/8/2004	9/14/2004	75	8/18/2004	8/24/2004	75	8/26/2004	9/1/2004	75
475	8/2/2004	8/13/2004	168	7/13/2004	7/26/2004	168	7/21/2004	8/3/2004	168
476	7/16/2004	7/23/2004	171	6/24/2004	7/1/2004	171	7/6/2004	7/13/2004	171
477	8/31/2004	9/8/2004	145	8/11/2004	8/18/2004	145	8/19/2004	8/26/2004	145
478	9/9/2004	9/16/2004	145	8/19/2004	8/26/2004	145	8/27/2004	9/3/2004	145
479	9/17/2004	9/30/2004	145	8/27/2004	9/10/2004	145	9/7/2004	9/20/2004	145
480	9/8/2004	9/13/2004	76	8/18/2004	8/23/2004	76	8/26/2004	8/31/2004	76
481	8/31/2004	9/10/2004	79	8/11/2004	8/20/2004	79	8/19/2004	8/30/2004	79
482	10/1/2004	10/6/2004	145	9/13/2004	9/16/2004	145	9/21/2004	9/24/2004	145
483	9/8/2004	9/13/2004	76	8/18/2004	8/23/2004	76	8/26/2004	8/31/2004	76
484	9/9/2004	9/21/2004	156	8/19/2004	8/31/2004	156	8/27/2004	9/9/2004	156
485	9/13/2004	9/15/2004	160	8/23/2004	8/25/2004	160	8/31/2004	9/2/2004	160
486	9/13/2004	9/24/2004	153	8/23/2004	9/3/2004	153	8/31/2004	9/14/2004	153
487	9/13/2004	9/13/2004	79	8/23/2004	8/23/2004	79	8/31/2004	8/31/2004	79
488	9/15/2004	9/17/2004	75	8/25/2004	8/27/2004	75	9/2/2004	9/7/2004	75
489	9/20/2004	9/29/2004	75	8/30/2004	9/9/2004	75	9/8/2004	9/17/2004	75
490	9/30/2004	10/4/2004	127	9/10/2004	9/14/2004	127	9/20/2004	9/22/2004	127
491	10/7/2004	10/20/2004	68	9/17/2004	9/30/2004	68	9/27/2004	10/8/2004	68
492	10/21/2004	11/3/2004	125	10/1/2004	10/14/2004	125	10/11/2004	10/22/2004	125
493	10/21/2004	10/28/2004	129	10/1/2004	10/8/2004	129	10/11/2004	10/18/2004	129
494	11/4/2004	11/10/2004	125	10/15/2004	10/21/2004	125	10/25/2004	10/29/2004	125
495	5/10/2004	11/30/2004	16	4/20/2004	11/8/2004	16	4/28/2004	11/16/2004	16
496	5/10/2004	5/13/2004	16	4/20/2004	4/23/2004	16	4/28/2004	5/3/2004	16
497	5/14/2004	5/19/2004	16	4/26/2004	4/29/2004	16	5/4/2004	5/7/2004	16
498	5/20/2004	5/25/2004	16	4/30/2004	5/5/2004	16	5/10/2004	5/13/2004	16
499	5/28/2004	6/11/2004	14	5/10/2004	5/21/2004	14	5/18/2004	6/1/2004	14
500	6/14/2004	7/6/2004	86	5/24/2004	6/14/2004	86	6/2/2004	6/22/2004	86

Table B-1: Continued [pg. 11 of 20]

ID	As-Planned Schedule			20-Jun-03			June 24, 2003 (Rescheduled)		
	Start	Finish	TF	Start	Finish	TF	Start	Finish	TF
501	6/14/2004	7/6/2004	86	5/24/2004	6/14/2004	86	6/2/2004	6/22/2004	86
502	7/6/2004	7/21/2004	0	6/14/2004	6/29/2004	0	6/22/2004	7/9/2004	0
503	6/24/2004	7/13/2004	91	6/4/2004	6/21/2004	91	6/14/2004	6/29/2004	91
504	6/30/2004	7/22/2004	84	6/10/2004	6/30/2004	84	6/18/2004	7/12/2004	84
505	7/17/2004	7/20/2004	86	6/15/2004	6/28/2004	86	6/23/2004	7/8/2004	86
506	7/17/2004	7/20/2004	86	6/15/2004	6/28/2004	86	6/23/2004	7/8/2004	86
507	7/22/2004	8/2/2004	77	6/30/2004	7/13/2004	77	7/12/2004	7/21/2004	77
508	7/23/2004	8/12/2004	168	7/1/2004	7/23/2004	168	7/13/2004	8/2/2004	168
509	8/6/2004	8/26/2004	168	7/19/2004	8/6/2004	168	7/27/2004	8/16/2004	168
510	8/20/2004	9/10/2004	168	8/2/2004	8/20/2004	168	8/10/2004	8/30/2004	168
511	6/14/2004	6/23/2004	96	5/24/2004	6/3/2004	96	6/2/2004	6/11/2004	96
512	6/24/2004	6/28/2004	108	6/4/2004	6/8/2004	108	6/14/2004	6/16/2004	108
513	6/29/2004	7/9/2004	108	6/9/2004	6/17/2004	108	6/17/2004	6/25/2004	108
514	5/14/2004	6/1/2004	134	4/26/2004	5/11/2004	134	5/4/2004	5/19/2004	134
515	6/24/2004	7/9/2004	96	6/4/2004	6/17/2004	96	6/14/2004	6/25/2004	96
516	7/12/2004	7/21/2004	96	6/18/2004	6/29/2004	96	6/28/2004	7/9/2004	96
517	7/22/2004	7/27/2004	96	6/30/2004	7/7/2004	96	7/12/2004	7/15/2004	96
518	7/28/2004	8/3/2004	96	7/8/2004	7/14/2004	96	7/16/2004	7/22/2004	96
519	8/4/2004	8/9/2004	96	7/15/2004	7/20/2004	96	7/23/2004	7/28/2004	96
520	8/10/2004	8/18/2004	96	7/21/2004	7/29/2004	96	7/29/2004	8/6/2004	96
521	8/19/2004	8/26/2004	96	7/30/2004	8/6/2004	96	8/9/2004	8/16/2004	96
522	8/27/2004	8/30/2004	96	8/9/2004	8/10/2004	96	8/17/2004	8/18/2004	96
523	8/31/2004	9/7/2004	96	8/11/2004	8/17/2004	96	8/19/2004	8/25/2004	96
524	9/8/2004	9/10/2004	96	8/18/2004	8/20/2004	96	8/26/2004	8/30/2004	96
525	10/21/2004	10/22/2004	68	10/1/2004	10/4/2004	68	10/11/2004	10/12/2004	68
526	6/14/2004	6/17/2004	96	5/24/2004	5/27/2004	96	6/2/2004	6/7/2004	96
527	6/18/2004	6/29/2004	96	5/28/2004	6/9/2004	96	6/8/2004	6/17/2004	96
528	6/30/2004	7/9/2004	96	6/10/2004	6/17/2004	96	6/18/2004	6/25/2004	96
529	7/23/2004	8/9/2004	157	7/1/2004	7/20/2004	157	7/13/2004	7/28/2004	157
530	8/3/2004	8/13/2004	77	7/14/2004	7/26/2004	77	7/22/2004	8/3/2004	77
531	8/9/2004	9/3/2004	81	7/20/2004	8/16/2004	81	7/28/2004	8/24/2004	81
532	8/16/2004	8/20/2004	77	7/27/2004	8/2/2004	77	8/4/2004	8/10/2004	77
533	8/23/2004	9/8/2004	77	8/3/2004	8/18/2004	77	8/11/2004	8/26/2004	77
534	9/2/2004	9/16/2004	77	8/13/2004	8/26/2004	77	8/23/2004	9/3/2004	77
535	9/7/2004	9/14/2004	81	8/17/2004	8/24/2004	81	8/25/2004	9/1/2004	81
536	9/17/2004	9/21/2004	77	8/27/2004	8/31/2004	77	9/7/2004	9/9/2004	77
537	9/22/2004	9/28/2004	77	9/1/2004	9/8/2004	77	9/10/2004	9/16/2004	77
538	9/7/2004	9/20/2004	148	8/17/2004	8/30/2004	148	8/25/2004	9/8/2004	148
539	8/10/2004	8/19/2004	157	7/21/2004	7/30/2004	157	7/29/2004	8/9/2004	157
540	8/20/2004	8/27/2004	157	8/2/2004	8/9/2004	157	8/10/2004	8/17/2004	157
541	8/30/2004	9/7/2004	157	8/10/2004	8/17/2004	157	8/18/2004	8/25/2004	157
542	9/21/2004	10/4/2004	148	8/31/2004	9/14/2004	148	9/9/2004	9/22/2004	148
543	9/22/2004	9/27/2004	78	9/1/2004	9/7/2004	78	9/10/2004	9/15/2004	78
544	9/15/2004	9/24/2004	81	8/25/2004	9/3/2004	81	9/2/2004	9/14/2004	81
545	10/5/2004	10/8/2004	148	9/15/2004	9/20/2004	148	9/23/2004	9/28/2004	148
546	9/22/2004	9/27/2004	78	9/1/2004	9/7/2004	78	9/10/2004	9/15/2004	78
547	9/22/2004	10/4/2004	152	9/1/2004	9/14/2004	152	9/10/2004	9/22/2004	152
548	9/27/2004	9/29/2004	155	9/7/2004	9/9/2004	155	9/15/2004	9/17/2004	155
549	9/27/2004	10/8/2004	148	9/7/2004	9/20/2004	148	9/15/2004	9/28/2004	148
550	9/27/2004	9/27/2004	81	9/7/2004	9/7/2004	81	9/15/2004	9/15/2004	81

Table B-1: Continued [pg. 12 of 20]

ID	As-Planned Schedule			20-Jun-03			June 24, 2003 (Rescheduled)		
	Start	Finish	TF	Start	Finish	TF	Start	Finish	TF
551	9/29/2004	10/1/2004	77	9/9/2004	9/13/2004	77	9/17/2004	9/21/2004	77
552	10/4/2004	10/13/2004	77	9/14/2004	9/23/2004	77	9/22/2004	10/1/2004	77
553	10/14/2004	10/18/2004	120	9/24/2004	9/28/2004	120	10/4/2004	10/6/2004	120
554	10/25/2004	11/5/2004	68	10/5/2004	10/18/2004	68	10/13/2004	10/26/2004	68
555	11/8/2004	11/19/2004	118	10/19/2004	11/1/2004	118	10/27/2004	11/9/2004	118
556	11/8/2004	11/15/2004	122	10/19/2004	10/26/2004	122	10/27/2004	11/3/2004	122
557	11/22/2004	11/30/2004	118	11/2/2004	11/8/2004	118	11/10/2004	11/16/2004	118
558	7/15/2003	11/10/2003	35	6/18/2003	10/21/2003	35	6/27/2003	10/29/2003	35
559	7/15/2003	7/15/2003	41	6/18/2003	6/18/2003	45	6/27/2003	6/27/2003	44
560	8/21/2003	9/2/2003	15	8/1/2003	8/12/2003	15	8/11/2003	8/20/2003	15
561	7/16/2003	7/18/2003	41	6/19/2003	6/23/2003	45	6/30/2003	7/2/2003	44
562	8/26/2003	9/5/2003	15	8/6/2003	8/15/2003	15	8/14/2003	8/25/2003	15
563	8/27/2003	9/8/2003	15	8/7/2003	8/18/2003	15	8/15/2003	8/26/2003	15
564	9/3/2003	9/23/2003	15	8/13/2003	9/3/2003	15	8/21/2003	9/11/2003	15
565	9/24/2003	10/1/2003	15	9/4/2003	9/11/2003	15	9/12/2003	9/19/2003	15
566	10/2/2003	10/15/2003	15	9/12/2003	9/25/2003	15	9/22/2003	10/3/2003	15
567	9/24/2003	9/30/2003	35	9/4/2003	9/10/2003	35	9/12/2003	9/18/2003	35
568	10/1/2003	10/2/2003	35	9/11/2003	9/12/2003	35	9/19/2003	9/22/2003	35
569	10/3/2003	10/15/2003	35	9/15/2003	9/25/2003	35	9/23/2003	10/3/2003	35
570	10/16/2003	10/22/2003	35	9/26/2003	10/2/2003	35	10/6/2003	10/10/2003	35
571	10/23/2003	11/5/2003	35	10/3/2003	10/16/2003	35	10/13/2003	10/24/2003	35
572	11/6/2003	11/6/2003	35	10/17/2003	10/17/2003	35	10/27/2003	10/27/2003	35
573	11/7/2003	11/10/2003	35	10/20/2003	10/21/2003	35	10/28/2003	10/29/2003	35
574	10/9/2003	12/10/2003	15	9/19/2003	11/18/2003	15	9/29/2003	11/26/2003	15
575	10/10/2003	10/15/2003	15	9/22/2003	9/25/2003	15	9/30/2003	10/3/2003	15
576	10/10/2003	10/23/2003	15	9/22/2003	10/3/2003	15	9/30/2003	10/13/2003	15
577	10/9/2003	10/22/2003	15	9/19/2003	10/2/2003	15	9/29/2003	10/10/2003	15
578	10/23/2003	10/28/2003	44	10/3/2003	10/8/2003	44	10/13/2003	10/16/2003	44
579	10/15/2003	11/4/2003	15	9/25/2003	10/15/2003	15	10/3/2003	10/23/2003	15
580	10/24/2003	11/10/2003	15	10/6/2003	10/21/2003	15	10/14/2003	10/29/2003	15
581	11/11/2003	11/24/2003	15	10/22/2003	11/4/2003	15	10/30/2003	11/12/2003	15
582	11/20/2003	11/25/2003	15	10/31/2003	11/5/2003	15	11/10/2003	11/13/2003	15
583	11/20/2003	12/3/2003	15	10/31/2003	11/11/2003	15	11/10/2003	11/19/2003	15
584	12/4/2003	12/4/2003	15	11/12/2003	11/12/2003	15	11/20/2003	11/20/2003	15
585	12/5/2003	12/10/2003	15	11/13/2003	11/18/2003	15	11/21/2003	11/26/2003	15
586	12/11/2003	3/17/2004	15	11/19/2003	2/26/2004	15	12/1/2003	3/5/2004	15
587	12/11/2003	1/14/2004	15	11/19/2003	12/18/2003	15	12/1/2003	12/31/2003	15
588	1/15/2004	1/19/2004	15	12/19/2003	12/23/2003	15	1/5/2004	1/7/2004	15
589	1/20/2004	1/22/2004	28	12/29/2003	12/31/2003	28	1/8/2004	1/12/2004	28
590	1/23/2004	1/26/2004	28	1/5/2004	1/6/2004	28	1/13/2004	1/14/2004	28
591	1/20/2004	1/29/2004	15	12/29/2003	1/9/2004	15	1/8/2004	1/19/2004	15
592	1/30/2004	2/9/2004	18	1/12/2004	1/20/2004	18	1/20/2004	1/28/2004	18
593	2/10/2004	2/13/2004	18	1/21/2004	1/26/2004	18	1/29/2004	2/3/2004	18
594	1/30/2004	2/10/2004	15	1/12/2004	1/21/2004	15	1/20/2004	1/29/2004	15
595	2/11/2004	2/13/2004	15	1/22/2004	1/26/2004	15	1/30/2004	2/3/2004	15
596	2/16/2004	2/18/2004	15	1/27/2004	1/29/2004	15	2/4/2004	2/6/2004	15
597	2/19/2004	2/23/2004	15	1/30/2004	2/3/2004	15	2/9/2004	2/11/2004	15
598	2/24/2004	3/8/2004	15	2/4/2004	2/17/2004	15	2/12/2004	2/25/2004	15
599	2/26/2004	3/12/2004	15	2/6/2004	2/23/2004	15	2/16/2004	3/2/2004	15
600	2/26/2004	3/17/2004	15	2/6/2004	2/26/2004	15	2/16/2004	3/5/2004	15

Table B-1: Continued [pg. 13 of 20]

ID	As-Planned Schedule			20-Jun-03			June 24, 2003 (Rescheduled)		
	Start	Finish	TF	Start	Finish	TF	Start	Finish	TF
601	2/19/2004	4/12/2004	35	1/30/2004	3/23/2004	35	2/9/2004	3/31/2004	35
602	3/18/2004	3/29/2004	15	2/27/2004	3/9/2004	15	3/8/2004	3/17/2004	15
603	3/25/2004	4/1/2004	29	3/5/2004	3/12/2004	29	3/15/2004	3/22/2004	29
604	2/19/2004	2/24/2004	98	1/30/2004	2/4/2004	98	2/9/2004	2/12/2004	98
605	2/25/2004	3/1/2004	98	2/5/2004	2/10/2004	98	2/13/2004	2/18/2004	98
606	3/2/2004	3/8/2004	98	2/11/2004	2/17/2004	98	2/19/2004	2/25/2004	98
607	4/2/2004	4/12/2004	37	3/15/2004	3/23/2004	37	3/23/2004	3/31/2004	37
608	4/2/2004	6/18/2004	29	3/15/2004	5/28/2004	29	3/23/2004	6/8/2004	29
609	4/2/2004	4/15/2004	29	3/15/2004	3/26/2004	29	3/23/2004	4/5/2004	29
610	4/16/2004	4/22/2004	29	3/29/2004	4/2/2004	29	4/6/2004	4/12/2004	29
611	4/23/2004	5/13/2004	29	4/5/2004	4/23/2004	29	4/13/2004	5/3/2004	29
612	4/28/2004	5/18/2004	29	4/8/2004	4/28/2004	29	4/16/2004	5/6/2004	29
613	5/13/2004	5/24/2004	220	4/23/2004	5/4/2004	220	5/3/2004	5/12/2004	220
614	5/25/2004	6/2/2004	220	5/5/2004	5/12/2004	220	5/13/2004	5/20/2004	220
615	6/3/2004	6/18/2004	220	5/13/2004	5/28/2004	220	5/21/2004	6/8/2004	220
616	3/30/2004	10/12/2004	15	3/10/2004	9/22/2004	15	3/18/2004	9/30/2004	15
617	3/30/2004	4/6/2004	15	3/10/2004	3/17/2004	15	3/18/2004	3/25/2004	15
618	4/7/2004	4/14/2004	15	3/18/2004	3/25/2004	15	3/26/2004	4/2/2004	15
619	4/15/2004	4/26/2004	15	3/26/2004	4/6/2004	15	4/5/2004	4/14/2004	15
620	4/27/2004	5/6/2004	15	4/7/2004	4/16/2004	15	4/15/2004	4/26/2004	15
621	5/7/2004	5/17/2004	15	4/19/2004	4/27/2004	15	4/27/2004	5/5/2004	15
622	5/18/2004	5/26/2004	15	4/28/2004	5/6/2004	15	5/6/2004	5/14/2004	15
623	5/27/2004	6/4/2004	15	5/7/2004	5/14/2004	15	5/17/2004	5/24/2004	15
624	6/7/2004	6/14/2004	15	5/17/2004	5/24/2004	15	5/25/2004	6/2/2004	15
625	4/22/2004	5/5/2004	56	4/2/2004	4/15/2004	56	4/12/2004	4/23/2004	56
626	5/6/2004	5/17/2004	63	4/16/2004	4/27/2004	63	4/26/2004	5/5/2004	63
627	5/18/2004	5/24/2004	76	4/28/2004	5/4/2004	76	5/6/2004	5/12/2004	76
628	6/15/2004	6/24/2004	72	5/25/2004	6/4/2004	72	6/3/2004	6/14/2004	72
629	5/28/2004	6/18/2004	40	5/10/2004	5/28/2004	40	5/18/2004	6/8/2004	40
630	6/21/2004	7/16/2004	40	6/1/2004	6/24/2004	40	6/9/2004	7/6/2004	40
631	7/19/2004	8/11/2004	40	6/25/2004	7/22/2004	40	7/7/2004	7/30/2004	40
632	8/12/2004	9/1/2004	40	7/23/2004	8/12/2004	40	8/2/2004	8/20/2004	40
633	9/2/2004	9/14/2004	147	8/13/2004	8/24/2004	147	8/23/2004	9/1/2004	147
634	8/12/2004	9/9/2004	160	7/23/2004	8/19/2004	160	8/2/2004	8/27/2004	160
635	9/2/2004	9/13/2004	158	8/13/2004	8/23/2004	158	8/23/2004	8/31/2004	158
636	8/19/2004	9/9/2004	160	7/30/2004	8/19/2004	160	8/9/2004	8/27/2004	160
637	8/12/2004	8/13/2004	178	7/23/2004	7/26/2004	178	8/2/2004	8/3/2004	178
638	9/15/2004	9/28/2004	147	8/25/2004	9/8/2004	147	9/2/2004	9/16/2004	147
639	9/29/2004	10/12/2004	147	9/9/2004	9/22/2004	147	9/17/2004	9/30/2004	147
640	3/18/2004	3/21/2005	34	2/27/2004	3/1/2005	34	3/8/2004	3/9/2005	34
641	5/19/2004	5/24/2004	29	4/29/2004	5/4/2004	29	5/7/2004	5/12/2004	29
642	6/15/2004	6/24/2004	15	5/25/2004	6/4/2004	15	6/3/2004	6/14/2004	15
643	3/18/2004	3/31/2004	108	2/27/2004	3/11/2004	108	3/8/2004	3/19/2004	108
644	4/1/2004	4/6/2004	108	3/12/2004	3/17/2004	108	3/22/2004	3/25/2004	108
645	6/25/2004	6/30/2004	31	6/7/2004	6/10/2004	31	6/15/2004	6/18/2004	31
646	7/1/2004	7/23/2004	31	6/11/2004	7/1/2004	31	6/21/2004	7/13/2004	31
647	6/25/2004	7/14/2004	18	6/7/2004	6/22/2004	18	6/15/2004	6/30/2004	18
648	6/25/2004	7/19/2004	15	6/7/2004	6/25/2004	15	6/15/2004	7/7/2004	15
649	7/22/2004	8/18/2004	0	6/30/2004	7/29/2004	0	7/12/2004	8/6/2004	0
650	6/25/2004	7/26/2004	43	6/7/2004	7/6/2004	43	6/15/2004	7/14/2004	43

Table B-1: Continued [pg. 14 of 20]

ID	As-Planned Schedule			20-Jun-03			June 24, 2003 (Rescheduled)		
	Start	Finish	TF	Start	Finish	TF	Start	Finish	TF
651	6/25/2004	7/26/2004	28	6/7/2004	7/6/2004	28	6/15/2004	7/14/2004	28
652	7/15/2004	8/4/2004	28	6/23/2004	7/15/2004	28	7/1/2004	7/23/2004	28
653	7/20/2004	8/9/2004	25	6/28/2004	7/20/2004	25	7/8/2004	7/28/2004	25
654	8/19/2004	9/9/2004	18	7/30/2004	8/19/2004	18	8/9/2004	8/27/2004	18
655	7/26/2004	8/2/2004	33	7/6/2004	7/13/2004	33	7/14/2004	7/21/2004	33
656	7/27/2004	8/16/2004	132	7/7/2004	7/27/2004	132	7/15/2004	8/4/2004	132
657	8/17/2004	9/7/2004	132	7/28/2004	8/17/2004	132	8/5/2004	8/25/2004	132
658	9/8/2004	9/28/2004	132	8/18/2004	9/8/2004	132	8/26/2004	9/16/2004	132
659	9/29/2004	10/19/2004	132	9/9/2004	9/29/2004	132	9/17/2004	10/7/2004	132
660	8/10/2004	8/25/2004	28	7/21/2004	8/5/2004	28	7/29/2004	8/13/2004	28
661	9/10/2004	9/17/2004	41	8/20/2004	8/27/2004	41	8/30/2004	9/7/2004	41
662	8/26/2004	9/16/2004	28	8/6/2004	8/26/2004	28	8/16/2004	9/3/2004	28
663	9/17/2004	10/4/2004	59	8/27/2004	9/14/2004	59	9/7/2004	9/22/2004	59
664	9/20/2004	10/1/2004	41	8/30/2004	9/13/2004	41	9/8/2004	9/21/2004	41
665	9/10/2004	9/30/2004	18	8/20/2004	9/10/2004	18	8/30/2004	9/20/2004	18
666	10/1/2004	10/12/2004	18	9/13/2004	9/22/2004	18	9/21/2004	9/30/2004	18
667	10/13/2004	10/26/2004	114	9/23/2004	10/6/2004	114	10/1/2004	10/14/2004	114
668	10/13/2004	10/26/2004	114	9/23/2004	10/6/2004	114	10/1/2004	10/14/2004	114
669	10/13/2004	11/2/2004	18	9/23/2004	10/13/2004	18	10/1/2004	10/21/2004	18
670	10/13/2004	10/26/2004	66	9/23/2004	10/6/2004	66	10/1/2004	10/14/2004	66
671	10/4/2004	10/15/2004	41	9/14/2004	9/27/2004	41	9/22/2004	10/5/2004	41
672	10/18/2004	10/25/2004	41	9/28/2004	10/5/2004	41	10/6/2004	10/13/2004	41
673	10/26/2004	10/28/2004	41	10/6/2004	10/8/2004	41	10/14/2004	10/18/2004	41
674	11/3/2004	11/23/2004	18	10/14/2004	11/3/2004	18	10/22/2004	11/11/2004	18
675	11/24/2004	12/2/2004	18	11/4/2004	11/10/2004	18	11/12/2004	11/18/2004	18
676	12/3/2004	12/16/2004	18	11/11/2004	11/24/2004	18	11/19/2004	12/6/2004	18
677	12/17/2004	12/28/2004	70	11/29/2004	12/7/2004	70	12/7/2004	12/15/2004	70
678	12/10/2004	1/10/2005	18	11/18/2004	12/17/2004	18	11/30/2004	12/28/2004	18
679	1/11/2005	1/24/2005	64	12/20/2004	1/4/2005	64	12/29/2004	1/12/2005	64
680	1/11/2005	1/17/2005	18	12/20/2004	12/27/2004	18	12/29/2004	1/5/2005	18
681	12/3/2004	12/8/2004	47	11/11/2004	11/16/2004	47	11/19/2004	11/24/2004	47
682	10/13/2004	10/18/2004	72	9/23/2004	9/28/2004	72	10/1/2004	10/6/2004	72
683	1/18/2005	1/27/2005	18	12/28/2004	1/7/2005	18	1/6/2005	1/17/2005	18
684	11/3/2004	11/16/2004	61	10/14/2004	10/27/2004	61	10/22/2004	11/4/2004	61
685	1/11/2005	1/17/2005	72	12/20/2004	12/27/2004	72	12/29/2004	1/5/2005	72
686	1/28/2005	2/17/2005	34	1/10/2005	1/28/2005	34	1/18/2005	2/7/2005	34
687	1/21/2005	2/10/2005	18	1/3/2005	1/21/2005	18	1/11/2005	1/31/2005	18
688	1/18/2005	1/18/2005	71	12/28/2004	12/28/2004	71	1/6/2005	1/6/2005	71
689	2/18/2005	3/10/2005	34	1/31/2005	2/18/2005	34	2/8/2005	2/28/2005	34
690	1/18/2005	1/26/2005	65	12/28/2004	1/6/2005	65	1/6/2005	1/14/2005	65
691	3/11/2005	3/21/2005	34	2/21/2005	3/1/2005	34	3/1/2005	3/9/2005	34
692	5/25/2004	4/25/2005	16	5/5/2004	4/5/2005	16	5/13/2004	4/13/2005	16
693	5/25/2004	6/15/2004	32	5/5/2004	5/25/2004	32	5/13/2004	6/3/2004	32
694	6/25/2004	7/12/2004	20	6/7/2004	6/18/2004	20	6/15/2004	6/28/2004	20
695	7/13/2004	7/16/2004	46	6/21/2004	6/24/2004	46	6/29/2004	7/6/2004	46
696	7/19/2004	8/6/2004	148	6/25/2004	7/19/2004	148	7/7/2004	7/27/2004	148
697	7/19/2004	7/22/2004	46	6/25/2004	6/30/2004	46	7/7/2004	7/12/2004	46
698	7/26/2004	8/10/2004	31	7/6/2004	7/21/2004	31	7/14/2004	7/29/2004	31
699	7/15/2004	8/11/2004	18	6/23/2004	7/22/2004	18	7/1/2004	7/30/2004	18
700	7/20/2004	8/16/2004	15	6/28/2004	7/27/2004	15	7/8/2004	8/4/2004	15

Table B-1: Continued [pg. 15 of 20]

ID	As-Planned Schedule			20-Jun-03			June 24, 2003 (Rescheduled)		
	Start	Finish	TF	Start	Finish	TF	Start	Finish	TF
701	8/19/2004	9/14/2004	0	7/30/2004	8/24/2004	0	8/9/2004	9/1/2004	0
702	7/27/2004	8/16/2004	43	7/7/2004	7/27/2004	43	7/15/2004	8/4/2004	43
703	7/27/2004	8/16/2004	28	7/7/2004	7/27/2004	28	7/15/2004	8/4/2004	28
704	8/5/2004	8/25/2004	28	7/16/2004	8/5/2004	28	7/26/2004	8/13/2004	28
705	8/10/2004	8/30/2004	25	7/21/2004	8/10/2004	25	7/29/2004	8/18/2004	25
706	9/15/2004	10/5/2004	15	8/25/2004	9/15/2004	15	9/2/2004	9/23/2004	15
707	7/23/2004	7/30/2004	46	7/11/2004	7/12/2004	46	7/13/2004	7/20/2004	46
708	8/17/2004	9/7/2004	72	7/28/2004	8/17/2004	72	8/5/2004	8/25/2004	72
709	8/31/2004	9/22/2004	25	8/11/2004	9/1/2004	25	8/19/2004	9/10/2004	25
710	10/6/2004	10/13/2004	16	9/16/2004	9/23/2004	16	9/24/2004	10/1/2004	16
711	10/14/2004	11/3/2004	16	9/24/2004	10/14/2004	16	10/4/2004	10/22/2004	16
712	11/4/2004	11/24/2004	16	10/15/2004	11/4/2004	16	10/25/2004	11/12/2004	16
713	8/9/2004	8/12/2004	148	7/20/2004	7/23/2004	148	7/28/2004	8/2/2004	148
714	9/15/2004	9/17/2004	123	8/25/2004	8/27/2004	123	9/2/2004	9/7/2004	123
715	9/20/2004	10/5/2004	123	8/30/2004	9/15/2004	123	9/8/2004	9/23/2004	123
716	10/14/2004	10/27/2004	65	9/24/2004	10/7/2004	65	10/4/2004	10/15/2004	65
717	11/29/2004	12/10/2004	16	11/5/2004	11/18/2004	16	11/15/2004	11/30/2004	16
718	12/13/2004	12/27/2004	83	11/19/2004	12/6/2004	83	12/1/2004	12/14/2004	83
719	12/13/2004	12/27/2004	83	11/19/2004	12/6/2004	83	12/1/2004	12/14/2004	83
720	12/13/2004	1/4/2005	16	11/19/2004	12/13/2004	16	12/1/2004	12/21/2004	16
721	12/13/2004	12/27/2004	61	11/19/2004	12/6/2004	61	12/1/2004	12/14/2004	61
722	11/29/2004	12/1/2004	60	11/5/2004	11/9/2004	60	11/15/2004	11/17/2004	60
723	1/5/2005	1/7/2005	62	12/14/2004	12/16/2004	62	12/22/2004	12/27/2004	62
724	1/10/2005	1/28/2005	62	12/17/2004	1/10/2005	62	12/28/2004	1/18/2005	62
725	1/20/2005	1/31/2005	62	12/30/2004	1/11/2005	62	1/10/2005	1/19/2005	62
726	1/20/2005	1/31/2005	62	12/30/2004	1/11/2005	62	1/10/2005	1/19/2005	62
727	10/28/2004	11/8/2004	65	10/8/2004	10/19/2004	65	10/18/2004	10/27/2004	65
728	11/9/2004	11/16/2004	65	10/20/2004	10/27/2004	65	10/28/2004	11/4/2004	65
729	11/17/2004	11/22/2004	65	10/28/2004	11/2/2004	65	11/5/2004	11/10/2004	65
730	12/20/2004	1/18/2005	16	11/30/2004	12/28/2004	16	12/8/2004	1/6/2005	16
731	1/19/2005	2/3/2005	16	12/29/2004	1/14/2005	16	1/7/2005	1/24/2005	16
732	2/4/2005	2/24/2005	16	1/17/2005	2/4/2005	16	1/25/2005	2/14/2005	16
733	2/25/2005	3/3/2005	16	2/7/2005	2/11/2005	16	2/15/2005	2/21/2005	16
734	3/4/2005	3/31/2005	16	2/14/2005	3/11/2005	16	2/22/2005	3/21/2005	16
735	4/1/2005	4/14/2005	16	3/14/2005	3/25/2005	16	3/22/2005	4/4/2005	16
736	2/25/2005	3/3/2005	39	2/7/2005	2/11/2005	39	2/15/2005	2/21/2005	39
737	2/25/2005	3/2/2005	47	2/7/2005	2/10/2005	47	2/15/2005	2/18/2005	47
738	2/4/2005	2/25/2005	25	1/17/2005	2/7/2005	25	1/25/2005	2/15/2005	25
739	12/13/2004	12/20/2004	68	11/19/2004	11/30/2004	68	12/1/2004	12/8/2004	68
740	2/25/2005	3/14/2005	27	2/7/2005	2/22/2005	27	2/15/2005	3/2/2005	27
741	1/5/2005	1/18/2005	56	12/14/2004	12/28/2004	56	12/22/2004	1/6/2005	56
742	4/1/2005	4/11/2005	19	3/14/2005	3/22/2005	19	3/22/2005	3/30/2005	19
743	2/22/2005	3/2/2005	25	2/2/2005	2/10/2005	25	2/10/2005	2/18/2005	25
744	1/5/2005	1/25/2005	61	12/14/2004	1/5/2005	61	12/22/2004	1/13/2005	61
745	3/4/2005	3/24/2005	24	2/14/2005	3/4/2005	24	2/22/2005	3/14/2005	24
746	3/4/2005	3/4/2005	45	2/14/2005	2/14/2005	45	2/22/2005	2/22/2005	45
747	3/18/2005	4/4/2005	24	2/28/2005	3/15/2005	24	3/8/2005	3/23/2005	24
748	3/4/2005	3/14/2005	39	2/14/2005	2/22/2005	39	2/22/2005	3/2/2005	39
749	4/15/2005	4/25/2005	16	3/28/2005	4/5/2005	16	4/5/2005	4/13/2005	16

Table B-1: Continued [pg. 16 of 20]

ID	As-Planned Schedule			20-Jun-03			June 24, 2003 (Rescheduled)		
	Start	Finish	TF	Start	Finish	TF	Start	Finish	TF
750	7/13/2004	11/29/2004	35	6/21/2004	11/5/2004	35	6/29/2004	11/15/2004	35
751	7/13/2004	7/16/2004	35	6/21/2004	6/24/2004	35	6/29/2004	7/6/2004	35
752	7/19/2004	7/20/2004	35	6/25/2004	6/28/2004	35	7/7/2004	7/8/2004	35
753	7/21/2004	8/10/2004	35	6/29/2004	7/21/2004	35	7/9/2004	7/29/2004	35
754	8/11/2004	8/18/2004	119	7/22/2004	7/29/2004	119	7/30/2004	8/6/2004	119
755	8/19/2004	8/24/2004	119	7/30/2004	8/4/2004	119	8/9/2004	8/12/2004	119
756	8/25/2004	8/30/2004	119	8/5/2004	8/10/2004	119	8/13/2004	8/18/2004	119
757	8/31/2004	9/1/2004	119	8/11/2004	8/12/2004	119	8/19/2004	8/20/2004	119
758	8/31/2004	9/1/2004	119	8/11/2004	8/12/2004	119	8/19/2004	8/20/2004	119
759	8/31/2004	8/31/2004	120	8/11/2004	8/11/2004	120	8/19/2004	8/19/2004	120
760	8/31/2004	9/1/2004	119	8/11/2004	8/12/2004	119	8/19/2004	8/20/2004	119
761	8/31/2004	8/31/2004	120	8/11/2004	8/11/2004	120	8/19/2004	8/19/2004	120
762	8/25/2004	8/25/2004	124	8/5/2004	8/5/2004	124	8/13/2004	8/13/2004	124
763	9/2/2004	9/16/2004	119	8/13/2004	8/26/2004	119	8/23/2004	9/3/2004	119
764	8/26/2004	8/31/2004	166	8/6/2004	8/11/2004	166	8/16/2004	8/19/2004	166
765	9/17/2004	10/4/2004	119	8/27/2004	9/14/2004	119	9/7/2004	9/22/2004	119
766	10/5/2004	10/25/2004	119	9/15/2004	10/5/2004	119	9/23/2004	10/13/2004	119
767	10/26/2004	10/29/2004	119	10/6/2004	10/11/2004	119	10/14/2004	10/19/2004	119
768	9/10/2004	9/23/2004	152	8/20/2004	9/2/2004	152	8/30/2004	9/13/2004	152
769	9/10/2004	9/23/2004	157	8/20/2004	9/2/2004	157	8/30/2004	9/13/2004	157
770	10/26/2004	11/8/2004	128	10/6/2004	10/19/2004	128	10/14/2004	10/27/2004	128
771	9/24/2004	9/30/2004	152	9/3/2004	9/10/2004	152	9/14/2004	9/20/2004	152
772	10/15/2004	10/22/2004	124	9/27/2004	10/4/2004	124	10/5/2004	10/12/2004	124
773	11/1/2004	11/12/2004	119	10/12/2004	10/25/2004	119	10/20/2004	11/2/2004	119
774	11/15/2004	11/16/2004	119	10/26/2004	10/27/2004	119	11/3/2004	11/4/2004	119
775	11/9/2004	11/10/2004	128	10/20/2004	10/21/2004	128	10/28/2004	10/29/2004	128
776	11/17/2004	11/23/2004	119	10/28/2004	11/3/2004	119	11/5/2004	11/11/2004	119
777	8/12/2004	8/25/2004	18	7/23/2004	8/5/2004	18	8/2/2004	8/13/2004	18
778	8/17/2004	8/30/2004	15	7/28/2004	8/10/2004	15	8/5/2004	8/18/2004	15
779	9/15/2004	9/28/2004	0	8/25/2004	9/8/2004	0	9/2/2004	9/16/2004	0
780	8/17/2004	8/24/2004	43	7/28/2004	8/4/2004	43	8/5/2004	8/12/2004	43
781	8/17/2004	8/30/2004	28	7/28/2004	8/10/2004	28	8/5/2004	8/18/2004	28
782	8/26/2004	9/2/2004	29	8/6/2004	8/13/2004	29	8/16/2004	8/23/2004	29
783	8/31/2004	9/8/2004	26	8/11/2004	8/18/2004	26	8/19/2004	8/26/2004	26
784	10/6/2004	10/15/2004	15	9/16/2004	9/27/2004	15	9/24/2004	10/5/2004	15
785	8/31/2004	9/3/2004	160	8/11/2004	8/16/2004	160	8/19/2004	8/24/2004	160
786	8/11/2004	8/20/2004	163	7/22/2004	8/2/2004	163	7/30/2004	8/10/2004	163
787	10/18/2004	10/21/2004	124	9/28/2004	10/1/2004	124	10/6/2004	10/11/2004	124
788	10/22/2004	10/26/2004	124	10/4/2004	10/6/2004	124	10/12/2004	10/14/2004	124
789	10/27/2004	11/4/2004	131	10/7/2004	10/15/2004	131	10/15/2004	10/25/2004	131
790	10/27/2004	11/1/2004	129	10/7/2004	10/12/2004	129	10/15/2004	10/20/2004	129
791	10/27/2004	11/1/2004	124	10/7/2004	10/12/2004	124	10/15/2004	10/20/2004	124
792	10/27/2004	10/28/2004	131	10/7/2004	10/8/2004	131	10/15/2004	10/18/2004	131
793	11/2/2004	11/8/2004	124	10/13/2004	10/19/2004	124	10/21/2004	10/27/2004	124
794	11/5/2004	11/5/2004	131	10/18/2004	10/18/2004	131	10/26/2004	10/26/2004	131
795	11/9/2004	11/11/2004	124	10/20/2004	10/22/2004	124	10/28/2004	11/1/2004	124
796	11/12/2004	11/15/2004	125	10/25/2004	10/26/2004	125	11/2/2004	11/3/2004	125
797	11/9/2004	11/15/2004	125	10/20/2004	10/26/2004	125	10/28/2004	11/3/2004	125
798	11/12/2004	11/15/2004	124	10/25/2004	10/26/2004	124	11/2/2004	11/3/2004	124
799	11/16/2004	11/16/2004	124	10/27/2004	10/27/2004	124	11/4/2004	11/4/2004	124
800	11/12/2004	11/15/2004	125	10/25/2004	10/26/2004	125	11/2/2004	11/3/2004	125
801	11/24/2004	11/29/2004	119	11/4/2004	11/5/2004	119	11/12/2004	11/15/2004	119

Table B-1: Continued [pg. 17 of 20]

ID	As-Planned Schedule			20-Jun-03			June 24, 2003 (Rescheduled)		
	Start	Finish	TF	Start	Finish	TF	Start	Finish	TF
802	7/16/2003	11/24/2003	143	6/19/2003	11/4/2003	147	6/30/2003	11/12/2003	146
803	7/16/2003	7/16/2003	143	6/19/2003	6/19/2003	147	6/30/2003	6/30/2003	146
804	7/17/2003	7/30/2003	143	6/20/2003	7/3/2003	147	7/1/2003	7/15/2003	146
805	9/3/2003	9/5/2003	120	8/13/2003	8/15/2003	120	8/21/2003	8/25/2003	120
806	9/8/2003	9/25/2003	120	8/18/2003	9/5/2003	120	8/26/2003	9/15/2003	120
807	9/9/2003	9/26/2003	120	8/19/2003	9/8/2003	120	8/27/2003	9/16/2003	120
808	9/15/2003	9/24/2003	123	8/25/2003	9/4/2003	123	9/3/2003	9/12/2003	123
809	9/25/2003	9/26/2003	133	9/5/2003	9/8/2003	133	9/15/2003	9/16/2003	133
810	9/23/2003	9/29/2003	120	9/3/2003	9/9/2003	120	9/11/2003	9/17/2003	120
811	9/30/2003	10/15/2003	120	9/10/2003	9/25/2003	120	9/18/2003	10/3/2003	120
812	10/16/2003	10/17/2003	120	9/26/2003	9/29/2003	120	10/6/2003	10/7/2003	120
813	10/20/2003	10/28/2003	120	9/30/2003	10/8/2003	120	10/8/2003	10/16/2003	120
814	10/29/2003	10/29/2003	120	10/9/2003	10/9/2003	120	10/17/2003	10/17/2003	120
815	10/30/2003	10/31/2003	120	10/10/2003	10/13/2003	120	10/20/2003	10/21/2003	120
816	11/3/2003	11/21/2003	204	10/14/2003	11/3/2003	204	10/22/2003	11/11/2003	204
817	11/3/2003	11/4/2003	120	10/14/2003	10/15/2003	120	10/22/2003	10/23/2003	120
818	11/5/2003	11/24/2003	120	10/16/2003	11/4/2003	120	10/24/2003	11/12/2003	120
819	1/15/2004	4/5/2004	90	12/19/2003	3/16/2004	90	1/5/2004	3/24/2004	90
820	1/15/2004	2/4/2004	90	12/19/2003	1/15/2004	90	1/5/2004	1/23/2004	90
821	2/5/2004	2/13/2004	90	1/16/2004	1/26/2004	90	1/26/2004	2/3/2004	90
822	2/16/2004	2/19/2004	90	1/27/2004	1/30/2004	90	2/4/2004	2/9/2004	90
823	2/20/2004	2/25/2004	90	2/2/2004	2/5/2004	90	2/10/2004	2/13/2004	90
824	2/26/2004	2/27/2004	94	2/6/2004	2/9/2004	94	2/16/2004	2/17/2004	94
825	2/20/2004	2/25/2004	90	2/2/2004	2/5/2004	90	2/10/2004	2/13/2004	90
826	2/26/2004	3/2/2004	90	2/6/2004	2/11/2004	90	2/16/2004	2/19/2004	90
827	3/1/2004	3/2/2004	94	2/10/2004	2/11/2004	94	2/18/2004	2/19/2004	94
828	2/16/2004	2/25/2004	90	1/27/2004	2/5/2004	90	2/4/2004	2/13/2004	90
829	2/26/2004	3/2/2004	90	2/6/2004	2/11/2004	90	2/16/2004	2/19/2004	90
830	3/3/2004	3/3/2004	90	2/12/2004	2/12/2004	90	2/20/2004	2/20/2004	90
831	3/4/2004	3/8/2004	90	2/13/2004	2/17/2004	90	2/23/2004	2/25/2004	90
832	3/9/2004	3/12/2004	90	2/18/2004	2/23/2004	90	2/26/2004	3/2/2004	90
833	3/15/2004	3/30/2004	91	2/24/2004	3/10/2004	91	3/3/2004	3/18/2004	91
834	3/31/2004	4/5/2004	110	3/11/2004	3/16/2004	110	3/19/2004	3/24/2004	110
835	3/31/2004	7/6/2004	91	3/11/2004	6/14/2004	91	3/19/2004	6/22/2004	91
836	3/31/2004	4/27/2004	91	3/11/2004	4/7/2004	91	3/19/2004	4/15/2004	91
837	3/31/2004	4/9/2004	109	3/11/2004	3/22/2004	109	3/19/2004	3/30/2004	109
838	4/28/2004	5/5/2004	91	4/8/2004	4/15/2004	91	4/16/2004	4/23/2004	91
839	5/6/2004	5/13/2004	91	4/16/2004	4/23/2004	91	4/26/2004	5/3/2004	91
840	5/14/2004	5/25/2004	233	4/26/2004	5/5/2004	233	5/4/2004	5/13/2004	233
841	5/26/2004	6/1/2004	233	5/6/2004	5/11/2004	233	5/14/2004	5/19/2004	233
842	6/21/2004	7/6/2004	220	6/1/2004	6/14/2004	220	6/9/2004	6/22/2004	220
843	6/15/2004	12/21/2004	25	5/25/2004	12/1/2004	25	6/3/2004	12/9/2004	25
844	6/15/2004	6/25/2004	25	5/25/2004	6/7/2004	25	6/3/2004	6/15/2004	25
845	6/28/2004	7/12/2004	25	6/8/2004	6/18/2004	25	6/16/2004	6/28/2004	25
846	7/13/2004	7/23/2004	25	6/21/2004	7/1/2004	25	6/29/2004	7/13/2004	25
847	7/26/2004	8/5/2004	25	7/6/2004	7/16/2004	25	7/14/2004	7/26/2004	25
848	6/28/2004	7/8/2004	79	6/8/2004	6/16/2004	79	6/16/2004	6/24/2004	79
849	7/13/2004	7/23/2004	81	6/21/2004	7/1/2004	81	6/29/2004	7/13/2004	81
850	7/26/2004	8/2/2004	90	7/6/2004	7/13/2004	90	7/14/2004	7/21/2004	90
851	8/6/2004	8/16/2004	93	7/19/2004	7/27/2004	93	7/27/2004	8/4/2004	93
852	9/2/2004	9/21/2004	40	8/13/2004	8/31/2004	40	8/23/2004	9/9/2004	40
853	9/22/2004	10/12/2004	40	9/1/2004	9/22/2004	40	9/10/2004	9/30/2004	40
854	10/13/2004	10/29/2004	40	9/23/2004	10/11/2004	40	10/1/2004	10/19/2004	40
855	11/1/2004	11/15/2004	40	10/12/2004	10/26/2004	40	10/20/2004	11/3/2004	40
856	11/2/2004	11/22/2004	40	10/13/2004	11/2/2004	40	10/21/2004	11/10/2004	40
857	11/9/2004	11/22/2004	108	10/20/2004	11/2/2004	108	10/28/2004	11/10/2004	108
858	11/16/2004	12/1/2004	103	10/27/2004	11/9/2004	103	11/4/2004	11/17/2004	103
859	12/2/2004	12/15/2004	103	11/10/2004	11/23/2004	103	11/18/2004	12/3/2004	103
860	12/16/2004	12/21/2004	103	11/24/2004	12/1/2004	103	12/6/2004	12/9/2004	103

Table B-1: Continued [pg. 18 of 20]

ID	As-Planned Schedule			20-Jun-03			June 24, 2003 (Rescheduled)		
	Start	Finish	TF	Start	Finish	TF	Start	Finish	TF
861	8/6/2004	3/23/2005	25	7/19/2004	3/3/2005	25	7/27/2004	3/11/2005	25
862	8/6/2004	8/12/2004	25	7/19/2004	7/23/2004	25	7/27/2004	8/2/2004	25
863	8/13/2004	8/26/2004	90	7/26/2004	8/6/2004	90	8/3/2004	8/16/2004	90
864	8/27/2004	8/31/2004	90	8/9/2004	8/11/2004	90	8/17/2004	8/19/2004	90
865	8/26/2004	9/7/2004	18	8/6/2004	8/17/2004	18	8/16/2004	8/25/2004	18
866	8/27/2004	9/10/2004	15	8/9/2004	8/20/2004	15	8/17/2004	8/30/2004	15
867	9/29/2004	10/19/2004	0	9/9/2004	9/29/2004	0	9/17/2004	10/7/2004	0
868	8/25/2004	9/3/2004	43	8/5/2004	8/16/2004	43	8/13/2004	8/24/2004	43
869	8/31/2004	9/16/2004	28	8/11/2004	8/26/2004	28	8/19/2004	9/3/2004	28
870	9/8/2004	9/15/2004	27	8/18/2004	8/25/2004	27	8/26/2004	9/2/2004	27
871	9/13/2004	9/20/2004	24	8/23/2004	8/30/2004	24	8/31/2004	9/8/2004	24
872	10/20/2004	10/29/2004	13	9/30/2004	10/11/2004	13	10/8/2004	10/19/2004	13
873	8/13/2004	8/18/2004	25	7/26/2004	7/29/2004	25	8/3/2004	8/6/2004	25
874	8/19/2004	9/3/2004	25	7/30/2004	8/16/2004	25	8/9/2004	8/24/2004	25
875	9/7/2004	9/16/2004	95	8/17/2004	8/26/2004	95	8/25/2004	9/3/2004	95
876	9/7/2004	9/9/2004	54	8/17/2004	8/19/2004	54	8/25/2004	8/27/2004	54
877	9/21/2004	10/18/2004	47	8/31/2004	9/28/2004	47	9/9/2004	10/6/2004	47
878	11/1/2004	11/4/2004	44	10/12/2004	10/15/2004	44	10/20/2004	10/25/2004	44
879	10/19/2004	11/1/2004	47	9/29/2004	10/12/2004	47	10/7/2004	10/20/2004	47
880	11/5/2004	11/18/2004	44	10/18/2004	10/29/2004	44	10/26/2004	11/8/2004	44
881	11/19/2004	11/30/2004	47	11/1/2004	11/8/2004	47	11/9/2004	11/16/2004	47
882	11/19/2004	12/2/2004	50	11/1/2004	11/10/2004	50	11/9/2004	11/18/2004	50
883	12/3/2004	12/13/2004	92	11/11/2004	11/19/2004	92	11/19/2004	12/1/2004	92
884	12/3/2004	12/14/2004	50	11/11/2004	11/22/2004	50	11/19/2004	12/2/2004	50
885	12/3/2004	12/9/2004	53	11/11/2004	11/17/2004	53	11/19/2004	11/29/2004	53
886	12/3/2004	12/14/2004	50	11/11/2004	11/22/2004	50	11/19/2004	12/2/2004	50
887	11/19/2004	12/8/2004	44	11/1/2004	11/16/2004	44	11/9/2004	11/24/2004	44
888	12/9/2004	12/22/2004	44	11/17/2004	12/2/2004	44	11/29/2004	12/10/2004	44
889	12/1/2004	12/7/2004	47	11/9/2004	11/15/2004	47	11/17/2004	11/23/2004	47
890	12/8/2004	12/13/2004	47	11/16/2004	11/19/2004	47	11/24/2004	12/1/2004	47
891	12/14/2004	12/17/2004	47	11/22/2004	11/29/2004	47	12/2/2004	12/7/2004	47
892	12/23/2004	1/5/2005	44	12/3/2004	12/14/2004	44	12/13/2004	12/22/2004	44
893	1/6/2005	1/10/2005	77	12/15/2004	12/17/2004	77	12/23/2004	12/28/2004	77
894	1/6/2005	1/10/2005	70	12/15/2004	12/17/2004	70	12/23/2004	12/28/2004	70
895	12/15/2004	12/17/2004	55	11/23/2004	11/29/2004	55	12/3/2004	12/7/2004	55
896	12/15/2004	12/17/2004	91	11/23/2004	11/29/2004	91	12/3/2004	12/7/2004	91
897	1/6/2005	1/11/2005	76	12/15/2004	12/20/2004	76	12/23/2004	12/29/2004	76
898	1/11/2005	1/19/2005	70	12/20/2004	12/29/2004	70	12/29/2004	1/7/2005	70
899	2/11/2005	3/3/2005	18	1/24/2005	2/11/2005	18	2/1/2005	2/21/2005	18
900	3/4/2005	3/17/2005	29	2/14/2005	2/25/2005	29	2/22/2005	3/7/2005	29

Table B-1: Continued [pg. 19 of 20]

ID	As-Planned Schedule			20-Jun-03			June 24, 2003 (Rescheduled)		
	Start	Finish	TF	Start	Finish	TF	Start	Finish	TF
901	1/6/2005	1/12/2005	75	12/15/2004	12/21/2004	75	12/23/2004	12/30/2004	75
902	3/18/2005	3/23/2005	29	2/28/2005	3/3/2005	29	3/8/2005	3/11/2005	29
903	8/13/2004	4/13/2005	19	7/26/2004	3/24/2005	19	8/3/2004	4/1/2005	19
904	8/13/2004	8/19/2004	30	7/26/2004	7/30/2004	30	8/3/2004	8/9/2004	30
905	9/8/2004	9/28/2004	18	8/18/2004	9/8/2004	18	8/26/2004	9/16/2004	18
906	9/13/2004	10/1/2004	15	8/23/2004	9/13/2004	15	8/31/2004	9/21/2004	15
907	10/20/2004	11/9/2004	0	9/30/2004	10/20/2004	0	10/8/2004	10/28/2004	0
908	9/7/2004	9/22/2004	43	8/17/2004	9/1/2004	43	8/25/2004	9/10/2004	43
909	9/17/2004	10/7/2004	28	8/27/2004	9/17/2004	28	9/7/2004	9/27/2004	28
910	9/29/2004	10/12/2004	18	9/9/2004	9/22/2004	18	9/17/2004	9/30/2004	18
911	10/4/2004	10/15/2004	15	9/14/2004	9/27/2004	15	9/22/2004	10/5/2004	15
912	11/4/2004	11/17/2004	10	10/15/2004	10/28/2004	10	10/25/2004	11/5/2004	10
913	8/20/2004	8/24/2004	33	8/2/2004	8/4/2004	33	8/10/2004	8/12/2004	33
914	9/7/2004	9/24/2004	25	8/17/2004	9/3/2004	25	8/25/2004	9/14/2004	25
915	10/8/2004	10/19/2004	63	9/20/2004	9/29/2004	63	9/28/2004	10/7/2004	63
916	9/27/2004	9/30/2004	26	9/7/2004	9/10/2004	26	9/15/2004	9/20/2004	26
917	10/18/2004	11/10/2004	15	9/28/2004	10/21/2004	15	10/6/2004	10/29/2004	15
918	11/18/2004	11/23/2004	18	10/29/2004	11/3/2004	18	11/8/2004	11/11/2004	18
919	11/18/2004	12/7/2004	10	10/29/2004	11/15/2004	10	11/8/2004	11/23/2004	10
920	12/8/2004	12/21/2004	10	11/16/2004	12/1/2004	10	11/24/2004	12/9/2004	10
921	11/24/2004	12/3/2004	55	11/4/2004	11/11/2004	55	11/12/2004	11/19/2004	55
922	12/22/2004	1/6/2005	10	12/2/2004	12/15/2004	10	12/10/2004	12/23/2004	10
923	1/7/2005	1/18/2005	76	12/16/2004	12/28/2004	76	12/27/2004	1/6/2005	76
924	1/7/2005	1/17/2005	39	12/16/2004	12/27/2004	39	12/27/2004	1/5/2005	39
925	1/7/2005	1/13/2005	41	12/16/2004	12/22/2004	41	12/27/2004	1/3/2005	41
926	1/7/2005	1/20/2005	10	12/16/2004	12/30/2004	10	12/27/2004	1/10/2005	10
927	1/21/2005	1/28/2005	10	1/3/2005	1/10/2005	10	1/11/2005	1/18/2005	10
928	1/31/2005	2/15/2005	10	1/11/2005	1/26/2005	10	1/19/2005	2/3/2005	10
929	2/16/2005	2/25/2005	10	1/27/2005	2/7/2005	10	2/4/2005	2/15/2005	10
930	12/6/2004	12/10/2004	55	11/12/2004	11/18/2004	55	11/22/2004	11/30/2004	55
931	12/13/2004	12/16/2004	55	11/19/2004	11/24/2004	55	12/1/2004	12/6/2004	55
932	12/17/2004	12/22/2004	55	11/29/2004	12/2/2004	55	12/7/2004	12/10/2004	55
933	2/28/2005	3/15/2005	10	2/8/2005	2/23/2005	10	2/16/2005	3/3/2005	10
934	3/16/2005	3/17/2005	36	2/24/2005	2/25/2005	36	3/4/2005	3/7/2005	36
935	3/16/2005	3/29/2005	19	2/24/2005	3/9/2005	19	3/4/2005	3/17/2005	19
936	1/21/2005	1/25/2005	45	1/3/2005	1/5/2005	45	1/11/2005	1/13/2005	45
937	1/26/2005	2/1/2005	65	1/6/2005	1/12/2005	65	1/14/2005	1/20/2005	65
938	3/16/2005	3/21/2005	31	2/24/2005	3/1/2005	31	3/4/2005	3/9/2005	31
939	3/30/2005	4/6/2005	19	3/10/2005	3/17/2005	19	3/18/2005	3/25/2005	19
940	3/16/2005	3/29/2005	10	2/24/2005	3/9/2005	10	3/4/2005	3/17/2005	10
941	3/23/2005	4/5/2005	20	3/3/2005	3/16/2005	20	3/11/2005	3/24/2005	20
942	3/30/2005	4/5/2005	20	3/10/2005	3/16/2005	20	3/18/2005	3/24/2005	20
943	4/7/2005	4/13/2005	19	3/18/2005	3/24/2005	19	3/28/2005	4/1/2005	19
944	8/20/2004	5/18/2005	0	8/2/2004	4/28/2005	0	8/10/2004	5/6/2005	0
945	8/20/2004	8/27/2004	37	8/2/2004	8/9/2004	37	8/10/2004	8/17/2004	37
946	9/29/2004	10/14/2004	23	9/9/2004	9/24/2004	23	9/17/2004	10/4/2004	23
947	10/4/2004	10/19/2004	20	9/14/2004	9/29/2004	20	9/22/2004	10/7/2004	20
948	11/10/2004	11/29/2004	0	10/21/2004	11/5/2004	0	10/29/2004	11/15/2004	0
949	9/23/2004	10/4/2004	43	9/2/2004	9/14/2004	43	9/13/2004	9/22/2004	43
950	10/8/2004	10/25/2004	28	9/20/2004	10/5/2004	28	9/28/2004	10/13/2004	28

Table B-1: Continued [pg. 20 of 20]

ID	As-Planned Schedule			20-Jun-03			June 24, 2003 (Rescheduled)		
	Start	Finish	TF	Start	Finish	TF	Start	Finish	TF
951	10/15/2004	10/26/2004	23	9/27/2004	10/6/2004	23	10/5/2004	10/14/2004	23
952	10/20/2004	10/29/2004	20	9/30/2004	10/11/2004	20	10/8/2004	10/19/2004	20
953	11/22/2004	12/3/2004	0	11/2/2004	11/11/2004	0	11/10/2004	11/19/2004	0
954	8/30/2004	9/8/2004	37	8/10/2004	8/18/2004	37	8/18/2004	8/26/2004	37
955	9/27/2004	10/15/2004	25	9/7/2004	9/27/2004	25	9/15/2004	10/5/2004	25
956	10/18/2004	10/29/2004	61	9/28/2004	10/11/2004	61	10/6/2004	10/19/2004	61
957	10/18/2004	10/22/2004	25	9/28/2004	10/4/2004	25	10/6/2004	10/12/2004	25
958	11/1/2004	11/5/2004	24	10/12/2004	10/18/2004	24	10/20/2004	10/26/2004	24
959	12/6/2004	12/16/2004	6	11/12/2004	11/24/2004	6	11/22/2004	12/6/2004	6
960	11/1/2004	11/24/2004	20	10/12/2004	11/4/2004	20	10/20/2004	11/12/2004	20
961	12/6/2004	12/13/2004	9	11/12/2004	11/19/2004	9	11/22/2004	12/1/2004	9
962	12/6/2004	12/27/2004	0	11/12/2004	12/6/2004	0	11/22/2004	12/14/2004	0
963	12/28/2004	1/13/2005	23	12/7/2004	12/22/2004	23	12/15/2004	1/3/2005	23
964	12/28/2004	1/11/2005	0	12/7/2004	12/20/2004	0	12/15/2004	12/29/2004	0
965	12/14/2004	12/23/2004	45	11/22/2004	12/3/2004	45	12/2/2004	12/13/2004	45
966	1/12/2005	1/25/2005	0	12/21/2004	1/5/2005	0	12/30/2004	1/13/2005	0
967	1/26/2005	2/4/2005	0	1/6/2005	1/17/2005	0	1/14/2005	1/25/2005	0
968	1/26/2005	2/4/2005	0	1/6/2005	1/17/2005	0	1/14/2005	1/25/2005	0
969	1/26/2005	2/2/2005	2	1/6/2005	1/13/2005	2	1/14/2005	1/21/2005	2
970	1/26/2005	2/8/2005	3	1/6/2005	1/19/2005	3	1/14/2005	1/27/2005	3
971	1/26/2005	2/1/2005	3	1/6/2005	1/12/2005	3	1/14/2005	1/20/2005	3
972	2/7/2005	2/22/2005	0	1/18/2005	2/2/2005	0	1/26/2005	2/10/2005	0
973	2/16/2005	3/1/2005	0	1/27/2005	2/9/2005	0	2/4/2005	2/17/2005	0
974	3/2/2005	3/17/2005	0	2/10/2005	2/25/2005	0	2/18/2005	3/7/2005	0
975	12/27/2004	1/3/2005	45	12/6/2004	12/10/2004	45	12/14/2004	12/20/2004	45
976	1/4/2005	1/7/2005	45	12/13/2004	12/16/2004	45	12/21/2004	12/27/2004	45
977	1/10/2005	1/13/2005	45	12/17/2004	12/22/2004	45	12/28/2004	1/3/2005	45
978	3/18/2005	3/31/2005	0	2/28/2005	3/11/2005	0	3/8/2005	3/21/2005	0
979	4/1/2005	4/4/2005	26	3/14/2005	3/15/2005	26	3/22/2005	3/23/2005	26
980	4/1/2005	4/4/2005	0	3/14/2005	3/15/2005	0	3/22/2005	3/23/2005	0
981	2/9/2005	2/11/2005	42	1/20/2005	1/24/2005	42	1/28/2005	2/1/2005	42
982	4/1/2005	4/5/2005	25	3/14/2005	3/16/2005	25	3/22/2005	3/24/2005	25
983	4/1/2005	4/7/2005	23	3/14/2005	3/18/2005	23	3/22/2005	3/28/2005	23
984	4/5/2005	4/14/2005	0	3/16/2005	3/25/2005	0	3/24/2005	4/4/2005	0
985	4/1/2005	4/14/2005	8	3/14/2005	3/25/2005	8	3/22/2005	4/4/2005	8
986	4/15/2005	4/26/2005	0	3/28/2005	4/6/2005	0	4/5/2005	4/14/2005	0
987	4/20/2005	5/3/2005	5	3/31/2005	4/13/2005	5	4/8/2005	4/21/2005	5
988	4/27/2005	5/2/2005	6	4/7/2005	4/12/2005	6	4/15/2005	4/20/2005	6
989	4/27/2005	5/10/2005	0	4/7/2005	4/20/2005	0	4/15/2005	4/28/2005	0
990	4/5/2005	4/7/2005	23	3/16/2005	3/18/2005	23	3/24/2005	3/28/2005	23
991	5/11/2005	5/17/2005	0	4/21/2005	4/27/2005	0	4/29/2005	5/5/2005	0
992	5/18/2005	5/18/2005	0	4/28/2005	4/28/2005	0	5/6/2005	5/6/2005	0
993	5/19/2005	5/19/2005	0	4/29/2005	4/29/2005	0	5/9/2005	5/9/2005	0

Appendix C

ATF Database for June 2003

Table C-1: ATF database for the June 2003 Update

ID	As Planned Schedule			20-Jun-03			June 24, 2003 (Rescheduled)		
	TF	Owner	KR	TF	Owner	KR	TF	Owner	KR
1	0	0	0	0	0	0	0		
2	75	37.5	37.5	386			381		
3	273	136.5	136.5	259	142.5	116.5	215	142.5	72.5
4	273	136.5	136.5	259	142.5	116.5	215	142.5	72.5
5	87	43.5	43.5	26	49.5	-23.5	29	51	-22
6	87	43.5	43.5	26	49.5	-23.5	29	51	-22
7	200	100	100	186	106	80	142	106	36
8	200	100	100	186	106	80	142	106	36
9	103	51.5	51.5	89	57.5	31.5	45	57.5	-12.5
10	103	51.5	51.5	89	57.5	31.5	45	57.5	-12.5
11	202	101	101	188	107	81	144	107	37
12	202	101	101	188	107	81	144	107	37
13	75	37.5	37.5	0	0	0	0	0	0
14	75	37.5	37.5	23	43.5	-20.5	29	46.5	-17.5
15	130	65	65	116	71	45	72	71	1
16	130	65	65	116	71	45	72	71	1
17	225	112.5	112.5	211	118.5	92.5	167	118.5	48.5
18	225	112.5	112.5	211	118.5	92.5	167	118.5	48.5
19	144	72	72	130	78	52	86	78	8
20	144	72	72	130	78	52	86	78	8
21	97	48.5	48.5	36	54.5	-18.5	42	57.5	-15.5
22	97	48.5	48.5	36	54.5	-18.5	42	57.5	-15.5
23	430	215	215	416	221	195	372	221	151
24	430	215	215	416	221	195	372	221	151
25	81	40.5	40.5	0	0	0	0	0	0
26	81	40.5	40.5	27	46.5	-19.5	33	49.5	-16.5
27	200	100	100	186	106	80	142	106	36
28	200	100	100	186	106	80	142	106	36
29	96	48	48	0	0	0	0	0	0
30	96	48	48	48	54	-6	51	55.5	-4.5
31	180	90	90	166	96	70	122	96	26
32	180	90	90	166	96	70	122	96	26
33	272	136	136	258	142	116	214	142	72
34	272	136	136	258	142	116	214	142	72
35	459	229.5	229.5	445	235.5	209.5	401	235.5	165.5
36	459	229.5	229.5	445	235.5	209.5	401	235.5	165.5
37	295	147.5	147.5	281	153.5	127.5	237	153.5	83.5
38	295	147.5	147.5	281	153.5	127.5	237	153.5	83.5
39	411	205.5	205.5	397	211.5	185.5	353	211.5	141.5
40	411	205.5	205.5	397	211.5	185.5	353	211.5	141.5
41	292	146	146	278	152	126	234	152	82
42	292	146	146	278	152	126	234	152	82
43	369	184.5	184.5	355	190.5	164.5	311	190.5	120.5
44	369	184.5	184.5	355	190.5	164.5	311	190.5	120.5
45	450	225	225	436	231	205	392	231	161
46	450	225	225	436	231	205	392	231	161
47	243	121.5	121.5	229	127.5	101.5	185	127.5	57.5
48	243	121.5	121.5	229	127.5	101.5	185	127.5	57.5
49	144	72	72	130	78	52	86	78	8
50	426	213	213	412	219	193	368	219	149

Table C-1: Continued [pg. 2 of 20]

ID	As Planned Schedule			20-Jun-03			June 24, 2003 (Rescheduled)		
	TF	Owner	KR	TF	Owner	KR	TF	Owner	KR
51	426	213	213	412	219	193	368	219	149
52	416	208	208	359	171	188	358	171	187
53	416	208	208	359	171	188	358	171	187
54	298	149	149	284	155	129	240	155	85
55	298	149	149	284	155	129	240	155	85
56	414	207	207	400	213	187	356	213	143
57	414	207	207	400	213	187	356	213	143
58	406	203	203	0	0	0	0	0	0
59	406	203	203	376	193	183	367	193	174
60	416	208	208	402	214	188	358	214	144
61	416	208	208	402	214	188	358	214	144
62	288	144	144	274	150	124	230	150	80
63	288	144	144	274	150	124	230	150	80
64	141	70.5	70.5	127	76.5	50.5	83	76.5	6.5
65	141	70.5	70.5	127	76.5	50.5	83	76.5	6.5
66	431	215.5	215.5	417	221.5	195.5	373	221.5	151.5
67	431	215.5	215.5	417	221.5	195.5	373	221.5	151.5
68	434	217	217	420	223	197	376	223	153
69	434	217	217	420	223	197	376	223	153
70	302	151	151	288	157	131	244	157	87
71	302	151	151	288	157	131	244	157	87
72	404	202	202	390	208	182	346	208	138
73	404	202	202	390	208	182	346	208	138
74	424	212	212	410	218	192	366	218	148
75	424	212	212	410	218	192	366	218	148
76	355	177.5	177.5	341	183.5	157.5	297	183.5	113.5
77	355	177.5	177.5	341	183.5	157.5	297	183.5	113.5
78	0			0			0		
79	0	0	0	0	0	0	0	0	0
80	0	0	0	0	0	0	0	0	0
81	22	11	11	0	0	0	0	0	0
82	22	11	11	0	13	-13	0	13	-13
83	287	143.5	143.5	0	0	0	0	0	0
84	287	143.5	143.5	0	0	0	0	0	0
85	8			0	4	-4	0	4	-4
86	26	13	13	0	0	0	0	0	0
87	8	4	4	0	0	0	0	0	0
88	22	11	11	0	0	0	0	0	0
89	0			435			428		
90	0	0	0	500	256.5	243.5	467	256.5	210.5
91	0	0	0	0	0	0	0	0	0
92	0	0	0	0	0	0	0	0	0
93	0	0	0	-12	0	-12	207	109.5	97.5
94	241	120.5	120.5	220	122.5	97.5	213	122.5	90.5
95	241	120.5	120.5	220	122.5	97.5	213	122.5	90.5
96	241	120.5	120.5	220	122.5	97.5	213	122.5	90.5
97	241	120.5	120.5	220	122.5	97.5	213	122.5	90.5
98	241	120.5	120.5	220	122.5	97.5	213	122.5	90.5
99	242	121	121	221	123	98	214	123	91
100	242	121	121	221	123	98	214	123	91

Table C-1: Continued [pg. 3 of 20]

ID	As Planned Schedule			20-Jun-03			June 24, 2003 (Rescheduled)		
	TF	Owner	KR	TF	Owner	KR	TF	Owner	KR
101	242	121	121	221	123	98	214	123	91
102	0	0	0	-12	0	-12	207	109.5	97.5
103	242	121	121	221	123	98	214	123	91
104	273			252			245		
105	273	136.5	136.5	252	138.5	113.5	245	138.5	106.5
106	273	136.5	136.5	252	138.5	113.5	245	138.5	106.5
107	273	136.5	136.5	252	138.5	113.5	245	138.5	106.5
108	273	136.5	136.5	252	138.5	113.5	245	138.5	106.5
109	273	136.5	136.5	252	138.5	113.5	245	138.5	106.5
110	273	136.5	136.5	252	138.5	113.5	245	138.5	106.5
111	273	136.5	136.5	252	138.5	113.5	245	138.5	106.5
112	276	138	138	255	140	115	248	140	108
113	0			226			219		
114	0	0	0	226	113	113	219	113	106
115	0	0	0	226	113	113	219	113	106
116	0	0	0	226	113	113	219	113	106
117	235			220			213		
118	235	117.5	117.5	226	119.5	106.5	219	119.5	99.5
119	235	117.5	117.5	226	119.5	106.5	219	119.5	99.5
120	235	117.5	117.5	220	119.5	100.5	213	119.5	93.5
121	242			233			226		
122	373	186.5	186.5	364	188.5	175.5	357	188.5	168.5
123	235	117.5	117.5	220	119.5	100.5	213	119.5	93.5
124	235	117.5	117.5	220	119.5	100.5	213	119.5	93.5
125	235	117.5	117.5	220	119.5	100.5	213	119.5	93.5
126	235	117.5	117.5	220	119.5	100.5	213	119.5	93.5
127	235	117.5	117.5	220	119.5	100.5	213	119.5	93.5
128	266	133	133	251	135	116	244	135	109
129	251	125.5	125.5	236	127.5	108.5	229	127.5	101.5
130	251	125.5	125.5	236	127.5	108.5	229	127.5	101.5
131	251	125.5	125.5	236	127.5	108.5	229	127.5	101.5
132	235	117.5	117.5	220	119.5	100.5	213	119.5	93.5
133	235	117.5	117.5	220	119.5	100.5	213	119.5	93.5
134	235	117.5	117.5	220	119.5	100.5	213	119.5	93.5
135	381	190.5	190.5	366	192.5	173.5	359	192.5	166.5
136	235	117.5	117.5	220	119.5	100.5	213	119.5	93.5
137	235	117.5	117.5	220	119.5	100.5	213	119.5	93.5
138	235	117.5	117.5	220	119.5	100.5	213	119.5	93.5
139	235	117.5	117.5	220	119.5	100.5	213	119.5	93.5
140	121			121			121		
141	272	136	136	257	138	119	250	138	112
142	272	136	136	257	138	119	250	138	112
143	272	136	136	257	138	119	250	138	112
144	272	136	136	257	138	119	250	138	112
145	272	136	136	257	138	119	250	138	112
146	72	36	36	72	36	36	72	36	36
147	235			220			213		
148	235	117.5	117.5	220	119.5	100.5	213	119.5	93.5
149	235	117.5	117.5	220	119.5	100.5	213	119.5	93.5
150	235	117.5	117.5	220	119.5	100.5	213	119.5	93.5

Table C-1: Continued [pg. 4 of 20]

ID	As Planned Schedule			20-Jun-03			June 24, 2003 (Rescheduled)		
	TF	Owner	KR	TF	Owner	KR	TF	Owner	KR
151	235	117.5	117.5	220	119.5	100.5	213	119.5	93.5
152	235	117.5	117.5	220	119.5	100.5	213	119.5	93.5
153	124			124			124		
154	124	62	62	124	62	62	124	62	62
155	124	62	62	124	62	62	124	62	62
156	124	62	62	124	62	62	124	62	62
157	124	62	62	124	62	62	124	62	62
158	124	62	62	124	62	62	124	62	62
159	124	62	62	124	62	62	124	62	62
160	124	62	62	124	62	62	124	62	62
161	124	62	62	124	62	62	124	62	62
162	57			57			57		
163	57	28.5	28.5	57	28.5	28.5	57	28.5	28.5
164	57	28.5	28.5	57	28.5	28.5	57	28.5	28.5
165	57	28.5	28.5	57	28.5	28.5	57	28.5	28.5
166	57	28.5	28.5	57	28.5	28.5	57	28.5	28.5
167	57	28.5	28.5	57	28.5	28.5	57	28.5	28.5
168	57	28.5	28.5	57	28.5	28.5	57	28.5	28.5
169	57	28.5	28.5	57	28.5	28.5	57	28.5	28.5
170	57	28.5	28.5	57	28.5	28.5	57	28.5	28.5
171	100	50	50	100	50	50	100	50	50
172	188			188			188		
173	188	94	94	188	94	94	188	94	94
174	188	94	94	188	94	94	188	94	94
175	188	94	94	188	94	94	188	94	94
176	188	94	94	188	94	94	188	94	94
177	188	94	94	188	94	94	188	94	94
178	188	94	94	188	94	94	188	94	94
179	135			135			135		
180	135	67.5	67.5	135	67.5	67.5	135	67.5	67.5
181	135	67.5	67.5	135	67.5	67.5	135	67.5	67.5
182	135	67.5	67.5	135	67.5	67.5	135	67.5	67.5
183	135	67.5	67.5	135	67.5	67.5	135	67.5	67.5
184	135	67.5	67.5	135	67.5	67.5	135	67.5	67.5
185	135	67.5	67.5	135	67.5	67.5	135	67.5	67.5
186	135	67.5	67.5	135	67.5	67.5	135	67.5	67.5
187	135	67.5	67.5	135	67.5	67.5	135	67.5	67.5
188	135	67.5	67.5	135	67.5	67.5	135	67.5	67.5
189	40			40			40		
190	40	20	20	40	20	20	40	20	20
191	40	20	20	40	20	20	40	20	20
192	40	20	20	40	20	20	40	20	20
193	40	20	20	40	20	20	40	20	20
194	40	20	20	40	20	20	40	20	20
195	40	20	20	40	20	20	40	20	20
196	40	20	20	40	20	20	40	20	20
197	40	20	20	40	20	20	40	20	20
198	40			40			40		
199	65	32.5	32.5	65	32.5	32.5	65	32.5	32.5
200	55	27.5	27.5	55	27.5	27.5	55	27.5	27.5
201	40	20	20	40	20	20	40	20	20

Table C-1: Continued [pg. 5 of 20]

ID	As Planned Schedule			20-Jun-03			June 24, 2003 (Rescheduled)		
	TF	Owner	KR	TF	Owner	KR	TF	Owner	KR
202	57			57			57		
203	57	28.5	28.5	57	28.5	28.5	57	28.5	28.5
204	57	28.5	28.5	57	28.5	28.5	57	28.5	28.5
205	57	28.5	28.5	57	28.5	28.5	57	28.5	28.5
206	57	28.5	28.5	57	28.5	28.5	57	28.5	28.5
207	57	28.5	28.5	57	28.5	28.5	57	28.5	28.5
208	57	28.5	28.5	57	28.5	28.5	57	28.5	28.5
209	57	28.5	28.5	57	28.5	28.5	57	28.5	28.5
210	57	28.5	28.5	57	28.5	28.5	57	28.5	28.5
211	57	28.5	28.5	57	28.5	28.5	57	28.5	28.5
212	57	28.5	28.5	57	28.5	28.5	57	28.5	28.5
213	57	28.5	28.5	57	28.5	28.5	57	28.5	28.5
214	111	55.5	55.5	111	55.5	55.5	111	55.5	55.5
215	77	38.5	38.5	77	38.5	38.5	77	38.5	38.5
216	77	38.5	38.5	77	38.5	38.5	77	38.5	38.5
217	57	28.5	28.5	57	28.5	28.5	57	28.5	28.5
218	57	28.5	28.5	57	28.5	28.5	57	28.5	28.5
219	57	28.5	28.5	57	28.5	28.5	57	28.5	28.5
220	57	28.5	28.5	57	28.5	28.5	57	28.5	28.5
221	57	28.5	28.5	57	28.5	28.5	57	28.5	28.5
222	57	28.5	28.5	57	28.5	28.5	57	28.5	28.5
223	57	28.5	28.5	57	28.5	28.5	57	28.5	28.5
224	57	28.5	28.5	57	28.5	28.5	57	28.5	28.5
225	78	39	39	78	39	39	78	39	39
226	76	38	38	76	38	38	76	38	38
227	76	38	38	76	38	38	76	38	38
228	57	28.5	28.5	57	28.5	28.5	57	28.5	28.5
229	71			71			71		
230	71	35.5	35.5	71	35.5	35.5	71	35.5	35.5
231	71	35.5	35.5	71	35.5	35.5	71	35.5	35.5
232	71	35.5	35.5	71	35.5	35.5	71	35.5	35.5
233	71	35.5	35.5	71	35.5	35.5	71	35.5	35.5
234	71	35.5	35.5	71	35.5	35.5	71	35.5	35.5
235	71	35.5	35.5	71	35.5	35.5	71	35.5	35.5
236	0			0			0		
237	0	0	0	0	0	0	0	0	0
238	0	0	0	0	0	0	0	0	0
239	0	0	0	0	0	0	0	0	0
240	8	4	4	8	4	4	8	4	4
241	0	0	0	0	0	0	0	0	0
242	0	0	0	0	0	0	0	0	0
243	0	0	0	0	0	0	0	0	0
244	1	0.5	0.5	1	0.5	0.5	1	0.5	0.5
245	0	0	0	0	0	0	0	0	0
246	0	0	0	0	0	0	0	0	0
247	0	0	0	0	0	0	0	0	0
248	0	0	0	0	0	0	0	0	0
249	0	0	0	0	0	0	0	0	0
250	0	0	0	0	0	0	0	0	0

Table C-1: Continued [pg. 6 of 20]

ID	As Planned Schedule			20-Jun-03			June 24, 2003 (Rescheduled)		
	TF	Owner	KR	TF	Owner	KR	TF	Owner	KR
251	0	0	0	0	0	0	0	0	0
252	1	0.5	0.5	1	0.5	0.5	1	0.5	0.5
253	0	0	0	0	0	0	0	0	0
254	6			6			6		
255	37	18.5	18.5	41	20.5	20.5	40	20.5	19.5
256	15	7.5	7.5	15	7.5	7.5	15	7.5	7.5
257	19	9.5	9.5	19	9.5	9.5	19	9.5	9.5
258	8	4	4	8	4	4	8	4	4
259	19	9.5	9.5	19	9.5	9.5	19	9.5	9.5
260	8	4	4	8	4	4	8	4	4
261	8	4	4	8	4	4	8	4	4
262	24	12	12	24	12	12	24	12	12
263	8	4	4	8	4	4	8	4	4
264	6	3	3	6	3	3	6	3	3
265	6	3	3	6	3	3	6	3	3
266	6	3	3	6	3	3	6	3	3
267	6	3	3	6	3	3	6	3	3
268	6	3	3	6	3	3	6	3	3
269	9	4.5	4.5	9	4.5	4.5	9	4.5	4.5
270	6	3	3	6	3	3	6	3	3
271	6	3	3	6	3	3	6	3	3
272	0			0			0		
273	0	0	0	0	0	0	0	0	0
274	0	0	0	0	0	0	0	0	0
275	0	0	0	0	0	0	0	0	0
276	3	1.5	1.5	3	1.5	1.5	3	1.5	1.5
277	3	1.5	1.5	3	1.5	1.5	3	1.5	1.5
278	6			6			6		
279	6	3	3	6	3	3	6	3	3
280	6	3	3	6	3	3	6	3	3
281	6	3	3	6	3	3	6	3	3
282	9	4.5	4.5	9	4.5	4.5	9	4.5	4.5
283	9	4.5	4.5	9	4.5	4.5	9	4.5	4.5
284	0			0			0		
285	0	0	0	0	0	0	0	0	0
286	0	0	0	0	0	0	0	0	0
287	0	0	0	0	0	0	0	0	0
288	3	1.5	1.5	3	1.5	1.5	3	1.5	1.5
289	3	1.5	1.5	3	1.5	1.5	3	1.5	1.5
290	5			5			5		
291	5	2.5	2.5	5	2.5	2.5	5	2.5	2.5
292	5	2.5	2.5	5	2.5	2.5	5	2.5	2.5
293	5	2.5	2.5	5	2.5	2.5	5	2.5	2.5
294	8	4	4	8	4	4	8	4	4
295	8	4	4	8	4	4	8	4	4
296	0			0			0		
297	0	0	0	0	0	0	0	0	0
298	3	1.5	1.5	3	1.5	1.5	3	1.5	1.5
299	3	1.5	1.5	3	1.5	1.5	3	1.5	1.5
300	3	1.5	1.5	3	1.5	1.5	3	1.5	1.5
301	3	1.5	1.5	3	1.5	1.5	3	1.5	1.5

Table C-1: Continued [pg. 7 of 20]

ID	As Planned Schedule			20-Jun-03			June 24, 2003 (Rescheduled)		
	TF	Owner	KR	TF	Owner	KR	TF	Owner	KR
302	0			0			0		
303	0	0	0	0	0	0	0	0	0
304	0	0	0	0	0	0	0	0	0
305	0	0	0	0	0	0	0	0	0
306	3	1.5	1.5	3	1.5	1.5	3	1.5	1.5
307	3	1.5	1.5	3	1.5	1.5	3	1.5	1.5
308	25	12.5	12.5	25	12.5	12.5	25	12.5	12.5
309	0			0			0		
310	0	0	0	0	0	0	0	0	0
311	0	0	0	0	0	0	0	0	0
312	0	0	0	0	0	0	0	0	0
313	0	0	0	0	0	0	0	0	0
314	0			0			0		
315	0	0	0	0	0	0	0	0	0
316	0	0	0	0	0	0	0	0	0
317	5	2.5	2.5	5	2.5	2.5	5	2.5	2.5
318	5	2.5	2.5	5	2.5	2.5	5	2.5	2.5
319	250	125	125	250	125	125	250	125	125
320	240	120	120	240	120	120	240	120	120
321	25			25			25		
322	25	12.5	12.5	25	12.5	12.5	25	12.5	12.5
323	25	12.5	12.5	25	12.5	12.5	25	12.5	12.5
324	0	0	0	0	0	0	0	0	0
325	0	0	0	0	0	0	0	0	0
326	0	0	0	0	0	0	0	0	0
327	240	120	120	240	120	120	240	120	120
328	240	120	120	240	120	120	240	120	120
329	40			40			40		
330	40	20	20	40	20	20	40	20	20
331	46	23	23	46	23	23	46	23	23
332	40	20	20	40	20	20	40	20	20
333	40	20	20	40	20	20	40	20	20
334	134	67	67	134	67	67	134	67	67
335	103	51.5	51.5	103	51.5	51.5	103	51.5	51.5
336	93	46.5	46.5	93	46.5	46.5	93	46.5	46.5
337	100	50	50	100	50	50	100	50	50
338	72	36	36	72	36	36	72	36	36
339	72	36	36	72	36	36	72	36	36
340	72	36	36	72	36	36	72	36	36
341	72	36	36	72	36	36	72	36	36
342	72	36	36	72	36	36	72	36	36
343	45			45			45		
344	45	22.5	22.5	45	22.5	22.5	45	22.5	22.5
345	46	23	23	46	23	23	46	23	23
346	40	20	20	40	20	20	40	20	20
347	40	20	20	40	20	20	40	20	20
348	256	128	128	256	128	128	256	128	128
349	251	125.5	125.5	251	125.5	125.5	251	125.5	125.5
350	235	117.5	117.5	235	117.5	117.5	235	117.5	117.5

Table C-1: Continued [pg. 8 of 20]

ID	As Planned Schedule			20-Jun-03			June 24, 2003 (Rescheduled)		
	TF	Owner	KR	TF	Owner	KR	TF	Owner	KR
351	244	122	122	244	122	122	244	122	122
352	57	28.5	28.5	57	28.5	28.5	57	28.5	28.5
353	57	28.5	28.5	57	28.5	28.5	57	28.5	28.5
354	57	28.5	28.5	57	28.5	28.5	57	28.5	28.5
355	195	97.5	97.5	195	97.5	97.5	195	97.5	97.5
356	194	97	97	194	97	97	194	97	97
357	0			0			0		
358	0	0	0	0	0	0	0	0	0
359	0	0	0	0	0	0	0	0	0
360	113	56.5	56.5	113	56.5	56.5	113	56.5	56.5
361	113	56.5	56.5	113	56.5	56.5	113	56.5	56.5
362	113	56.5	56.5	113	56.5	56.5	113	56.5	56.5
363	0	0	0	0	0	0	0	0	0
364	0	0	0	0	0	0	0	0	0
365	68	34	34	68	34	34	68	34	34
366	68	34	34	68	34	34	68	34	34
367	0	0	0	0	0	0	0	0	0
368	83	41.5	41.5	83	41.5	41.5	83	41.5	41.5
369	82	41	41	82	41	41	82	41	41
370	68	34	34	68	34	34	68	34	34
371	68	34	34	68	34	34	68	34	34
372	77	38.5	38.5	77	38.5	38.5	77	38.5	38.5
373	80	40	40	80	40	40	80	40	40
374	80	40	40	80	40	40	80	40	40
375	80	40	40	80	40	40	80	40	40
376	176	88	88	176	88	88	176	88	88
377	68	34	34	68	34	34	68	34	34
378	72	36	36	72	36	36	72	36	36
379	68	34	34	68	34	34	68	34	34
380	68	34	34	68	34	34	68	34	34
381	68	34	34	68	34	34	68	34	34
382	72	36	36	72	36	36	72	36	36
383	68	34	34	68	34	34	68	34	34
384	68	34	34	68	34	34	68	34	34
385	171	85.5	85.5	171	85.5	85.5	171	85.5	85.5
386	176	88	88	176	88	88	176	88	88
387	148	74	74	148	74	74	148	74	74
388	148	74	74	148	74	74	148	74	74
389	148	74	74	148	74	74	148	74	74
390	69	34.5	34.5	69	34.5	34.5	69	34.5	34.5
391	72	36	36	72	36	36	72	36	36
392	148	74	74	148	74	74	148	74	74
393	72	36	36	72	36	36	72	36	36
394	159	79.5	79.5	159	79.5	79.5	159	79.5	79.5
395	163	81.5	81.5	163	81.5	81.5	163	81.5	81.5
396	156	78	78	156	78	78	156	78	78
397	72	36	36	72	36	36	72	36	36
398	68	34	34	68	34	34	68	34	34
399	68	34	34	68	34	34	68	34	34
400	136	68	68	136	68	68	136	68	68

Table C-1: Continued [pg. 9 of 20]

ID	As Planned Schedule			20-Jun-03			June 24, 2003 (Rescheduled)		
	TF	Owner	KR	TF	Owner	KR	TF	Owner	KR
401	68	34	34	68	34	34	68	34	34
402	135	67.5	67.5	135	67.5	67.5	135	67.5	67.5
403	139	69.5	69.5	139	69.5	69.5	139	69.5	69.5
404	135	67.5	67.5	135	67.5	67.5	135	67.5	67.5
405	7			7			7		
406	7	3.5	3.5	7	3.5	3.5	7	3.5	3.5
407	7	3.5	3.5	7	3.5	3.5	7	3.5	3.5
408	7	3.5	3.5	7	3.5	3.5	7	3.5	3.5
409	7	3.5	3.5	7	3.5	3.5	7	3.5	3.5
410	79	39.5	39.5	79	39.5	39.5	79	39.5	39.5
411	79	39.5	39.5	79	39.5	39.5	79	39.5	39.5
412	0	0	0	0	0	0	0	0	0
413	90	45	45	90	45	45	90	45	45
414	89	44.5	44.5	89	44.5	44.5	89	44.5	44.5
415	79	39.5	39.5	79	39.5	39.5	79	39.5	39.5
416	79	39.5	39.5	79	39.5	39.5	79	39.5	39.5
417	77	38.5	38.5	77	38.5	38.5	77	38.5	38.5
418	84	42	42	84	42	42	84	42	42
419	84	42	42	84	42	42	84	42	42
420	84	42	42	84	42	42	84	42	42
421	77	38.5	38.5	77	38.5	38.5	77	38.5	38.5
422	178	89	89	178	89	89	178	89	89
423	81	40.5	40.5	81	40.5	40.5	81	40.5	40.5
424	77	38.5	38.5	77	38.5	38.5	77	38.5	38.5
425	77	38.5	38.5	77	38.5	38.5	77	38.5	38.5
426	77	38.5	38.5	77	38.5	38.5	77	38.5	38.5
427	81	40.5	40.5	81	40.5	40.5	81	40.5	40.5
428	77	38.5	38.5	77	38.5	38.5	77	38.5	38.5
429	77	38.5	38.5	77	38.5	38.5	77	38.5	38.5
430	175	87.5	87.5	175	87.5	87.5	175	87.5	87.5
431	178	89	89	178	89	89	178	89	89
432	152	76	76	152	76	76	152	76	76
433	152	76	76	152	76	76	152	76	76
434	152	76	76	152	76	76	152	76	76
435	78	39	39	78	39	39	78	39	39
436	81	40.5	40.5	81	40.5	40.5	81	40.5	40.5
437	152	76	76	152	76	76	152	76	76
438	78	39	39	78	39	39	78	39	39
439	163	81.5	81.5	163	81.5	81.5	163	81.5	81.5
440	167	83.5	83.5	167	83.5	83.5	167	83.5	83.5
441	160	80	80	160	80	80	160	80	80
442	81	40.5	40.5	81	40.5	40.5	81	40.5	40.5
443	77	38.5	38.5	77	38.5	38.5	77	38.5	38.5
444	77	38.5	38.5	77	38.5	38.5	77	38.5	38.5
445	136	68	68	136	68	68	136	68	68
446	68	34	34	68	34	34	68	34	34
447	130	65	65	130	65	65	130	65	65
448	134	67	67	134	67	67	134	67	67
449	130	65	65	130	65	65	130	65	65

Table C-1: Continued [pg. 10 of 20]

ID	As Planned Schedule			20-Jun-03			June 24, 2003 (Rescheduled)		
	TF	Owner	KR	TF	Owner	KR	TF	Owner	KR
450	10			10			10		
451	10	5	5	10	5	5	10	5	5
452	10	5	5	10	5	5	10	5	5
453	10	5	5	10	5	5	10	5	5
454	10	5	5	10	5	5	10	5	5
455	75	37.5	37.5	75	37.5	37.5	75	37.5	37.5
456	75	37.5	37.5	75	37.5	37.5	75	37.5	37.5
457	0	0	0	0	0	0	0	0	0
458	91	45.5	45.5	91	45.5	45.5	91	45.5	45.5
459	84	42	42	84	42	42	84	42	42
460	75	37.5	37.5	75	37.5	37.5	75	37.5	37.5
461	75	37.5	37.5	75	37.5	37.5	75	37.5	37.5
462	77	38.5	38.5	77	38.5	38.5	77	38.5	38.5
463	90	45	45	90	45	45	90	45	45
464	90	45	45	90	45	45	90	45	45
465	90	45	45	90	45	45	90	45	45
466	171	85.5	85.5	171	85.5	85.5	171	85.5	85.5
467	75	37.5	37.5	75	37.5	37.5	75	37.5	37.5
468	79	39.5	39.5	79	39.5	39.5	79	39.5	39.5
469	75	37.5	37.5	75	37.5	37.5	75	37.5	37.5
470	75	37.5	37.5	75	37.5	37.5	75	37.5	37.5
471	75	37.5	37.5	75	37.5	37.5	75	37.5	37.5
472	79	39.5	39.5	79	39.5	39.5	79	39.5	39.5
473	75	37.5	37.5	75	37.5	37.5	75	37.5	37.5
474	75	37.5	37.5	75	37.5	37.5	75	37.5	37.5
475	168	84	84	168	84	84	168	84	84
476	171	85.5	85.5	171	85.5	85.5	171	85.5	85.5
477	145	72.5	72.5	145	72.5	72.5	145	72.5	72.5
478	145	72.5	72.5	145	72.5	72.5	145	72.5	72.5
479	145	72.5	72.5	145	72.5	72.5	145	72.5	72.5
480	76	38	38	76	38	38	76	38	38
481	79	39.5	39.5	79	39.5	39.5	79	39.5	39.5
482	145	72.5	72.5	145	72.5	72.5	145	72.5	72.5
483	76	38	38	76	38	38	76	38	38
484	156	78	78	156	78	78	156	78	78
485	160	80	80	160	80	80	160	80	80
486	153	76.5	76.5	153	76.5	76.5	153	76.5	76.5
487	79	39.5	39.5	79	39.5	39.5	79	39.5	39.5
488	75	37.5	37.5	75	37.5	37.5	75	37.5	37.5
489	75	37.5	37.5	75	37.5	37.5	75	37.5	37.5
490	127	63.5	63.5	127	63.5	63.5	127	63.5	63.5
491	68	34	34	68	34	34	68	34	34
492	125	62.5	62.5	125	62.5	62.5	125	62.5	62.5
493	129	64.5	64.5	129	64.5	64.5	129	64.5	64.5
494	125	62.5	62.5	125	62.5	62.5	125	62.5	62.5
495	16			16			16		
496	16	8	8	16	8	8	16	8	8
497	16	8	8	16	8	8	16	8	8
498	16	8	8	16	8	8	16	8	8
499	14	7	7	14	7	7	14	7	7
500	86	43	43	86	43	43	86	43	43

Table C-1: Continued [pg. 11 of 20]

ID	As Planned Schedule			20-Jun-03			June 24, 2003 (Rescheduled)		
	TF	Owner	KR	TF	Owner	KR	TF	Owner	KR
501	86	43	43	86	43	43	86	43	43
502	0	0	0	0	0	0	0	0	0
503	91	45.5	45.5	91	45.5	45.5	91	45.5	45.5
504	84	42	42	84	42	42	84	42	42
505	86	43	43	86	43	43	86	43	43
506	86	43	43	86	43	43	86	43	43
507	77	38.5	38.5	77	38.5	38.5	77	38.5	38.5
508	168	84	84	168	84	84	168	84	84
509	168	84	84	168	84	84	168	84	84
510	168	84	84	168	84	84	168	84	84
511	96	48	48	96	48	48	96	48	48
512	108	54	54	108	54	54	108	54	54
513	108	54	54	108	54	54	108	54	54
514	134	67	67	134	67	67	134	67	67
515	96	48	48	96	48	48	96	48	48
516	96	48	48	96	48	48	96	48	48
517	96	48	48	96	48	48	96	48	48
518	96	48	48	96	48	48	96	48	48
519	96	48	48	96	48	48	96	48	48
520	96	48	48	96	48	48	96	48	48
521	96	48	48	96	48	48	96	48	48
522	96	48	48	96	48	48	96	48	48
523	96	48	48	96	48	48	96	48	48
524	96	48	48	96	48	48	96	48	48
525	68	34	34	68	34	34	68	34	34
526	96	48	48	96	48	48	96	48	48
527	96	48	48	96	48	48	96	48	48
528	96	48	48	96	48	48	96	48	48
529	157	78.5	78.5	157	78.5	78.5	157	78.5	78.5
530	77	38.5	38.5	77	38.5	38.5	77	38.5	38.5
531	81	40.5	40.5	81	40.5	40.5	81	40.5	40.5
532	77	38.5	38.5	77	38.5	38.5	77	38.5	38.5
533	77	38.5	38.5	77	38.5	38.5	77	38.5	38.5
534	77	38.5	38.5	77	38.5	38.5	77	38.5	38.5
535	81	40.5	40.5	81	40.5	40.5	81	40.5	40.5
536	77	38.5	38.5	77	38.5	38.5	77	38.5	38.5
537	77	38.5	38.5	77	38.5	38.5	77	38.5	38.5
538	148	74	74	148	74	74	148	74	74
539	157	78.5	78.5	157	78.5	78.5	157	78.5	78.5
540	157	78.5	78.5	157	78.5	78.5	157	78.5	78.5
541	157	78.5	78.5	157	78.5	78.5	157	78.5	78.5
542	148	74	74	148	74	74	148	74	74
543	78	39	39	78	39	39	78	39	39
544	81	40.5	40.5	81	40.5	40.5	81	40.5	40.5
545	148	74	74	148	74	74	148	74	74
546	78	39	39	78	39	39	78	39	39
547	152	76	76	152	76	76	152	76	76
548	155	77.5	77.5	155	77.5	77.5	155	77.5	77.5
549	148	74	74	148	74	74	148	74	74
550	81	40.5	40.5	81	40.5	40.5	81	40.5	40.5

Table C-1: Continued [pg. 12 of 20]

ID	As Planned Schedule			20-Jun-03			June 24, 2003 (Rescheduled)		
	TF	Owner	KR	TF	Owner	KR	TF	Owner	KR
551	77	38.5	38.5	77	38.5	38.5	77	38.5	38.5
552	77	38.5	38.5	77	38.5	38.5	77	38.5	38.5
553	120	60	60	120	60	60	120	60	60
554	68	34	34	68	34	34	68	34	34
555	118	59	59	118	59	59	118	59	59
556	122	61	61	122	61	61	122	61	61
557	118	59	59	118	59	59	118	59	59
558	35			35			35		
559	41	20.5	20.5	45	22.5	22.5	44	22.5	21.5
560	15	7.5	7.5	15	7.5	7.5	15	7.5	7.5
561	41	20.5	20.5	45	22.5	22.5	44	22.5	21.5
562	15	7.5	7.5	15	7.5	7.5	15	7.5	7.5
563	15	7.5	7.5	15	7.5	7.5	15	7.5	7.5
564	15	7.5	7.5	15	7.5	7.5	15	7.5	7.5
565	15	7.5	7.5	15	7.5	7.5	15	7.5	7.5
566	15	7.5	7.5	15	7.5	7.5	15	7.5	7.5
567	35	17.5	17.5	35	17.5	17.5	35	17.5	17.5
568	35	17.5	17.5	35	17.5	17.5	35	17.5	17.5
569	35	17.5	17.5	35	17.5	17.5	35	17.5	17.5
570	35	17.5	17.5	35	17.5	17.5	35	17.5	17.5
571	35	17.5	17.5	35	17.5	17.5	35	17.5	17.5
572	35	17.5	17.5	35	17.5	17.5	35	17.5	17.5
573	35	17.5	17.5	35	17.5	17.5	35	17.5	17.5
574	15			15			15		
575	15	7.5	7.5	15	7.5	7.5	15	7.5	7.5
576	15	7.5	7.5	15	7.5	7.5	15	7.5	7.5
577	15	7.5	7.5	15	7.5	7.5	15	7.5	7.5
578	44	22	22	44	22	22	44	22	22
579	15	7.5	7.5	15	7.5	7.5	15	7.5	7.5
580	15	7.5	7.5	15	7.5	7.5	15	7.5	7.5
581	15	7.5	7.5	15	7.5	7.5	15	7.5	7.5
582	15	7.5	7.5	15	7.5	7.5	15	7.5	7.5
583	15	7.5	7.5	15	7.5	7.5	15	7.5	7.5
584	15	7.5	7.5	15	7.5	7.5	15	7.5	7.5
585	15	7.5	7.5	15	7.5	7.5	15	7.5	7.5
586	15			15			15		
587	15	7.5	7.5	15	7.5	7.5	15	7.5	7.5
588	15	7.5	7.5	15	7.5	7.5	15	7.5	7.5
589	28	14	14	28	14	14	28	14	14
590	28	14	14	28	14	14	28	14	14
591	15	7.5	7.5	15	7.5	7.5	15	7.5	7.5
592	18	9	9	18	9	9	18	9	9
593	18	9	9	18	9	9	18	9	9
594	15	7.5	7.5	15	7.5	7.5	15	7.5	7.5
595	15	7.5	7.5	15	7.5	7.5	15	7.5	7.5
596	15	7.5	7.5	15	7.5	7.5	15	7.5	7.5
597	15	7.5	7.5	15	7.5	7.5	15	7.5	7.5
598	15	7.5	7.5	15	7.5	7.5	15	7.5	7.5
599	15	7.5	7.5	15	7.5	7.5	15	7.5	7.5
600	15	7.5	7.5	15	7.5	7.5	15	7.5	7.5

Table C-1: Continued [pg. 13 of 20]

ID	As Planned Schedule			20-Jun-03			June 24, 2003 (Rescheduled)		
	TF	Owner	KR	TF	Owner	KR	TF	Owner	KR
601	35			35			35		
602	15	7.5	7.5	15	7.5	7.5	15	7.5	7.5
603	29	14.5	14.5	29	14.5	14.5	29	14.5	14.5
604	98	49	49	98	49	49	98	49	49
605	98	49	49	98	49	49	98	49	49
606	98	49	49	98	49	49	98	49	49
607	37	18.5	18.5	37	18.5	18.5	37	18.5	18.5
608	29			29			29		
609	29	14.5	14.5	29	14.5	14.5	29	14.5	14.5
610	29	14.5	14.5	29	14.5	14.5	29	14.5	14.5
611	29	14.5	14.5	29	14.5	14.5	29	14.5	14.5
612	29	14.5	14.5	29	14.5	14.5	29	14.5	14.5
613	220	110	110	220	110	110	220	110	110
614	220	110	110	220	110	110	220	110	110
615	220	110	110	220	110	110	220	110	110
616	15			15			15		
617	15	7.5	7.5	15	7.5	7.5	15	7.5	7.5
618	15	7.5	7.5	15	7.5	7.5	15	7.5	7.5
619	15	7.5	7.5	15	7.5	7.5	15	7.5	7.5
620	15	7.5	7.5	15	7.5	7.5	15	7.5	7.5
621	15	7.5	7.5	15	7.5	7.5	15	7.5	7.5
622	15	7.5	7.5	15	7.5	7.5	15	7.5	7.5
623	15	7.5	7.5	15	7.5	7.5	15	7.5	7.5
624	15	7.5	7.5	15	7.5	7.5	15	7.5	7.5
625	56	28	28	56	28	28	56	28	28
626	63	31.5	31.5	63	31.5	31.5	63	31.5	31.5
627	76	38	38	76	38	38	76	38	38
628	72	36	36	72	36	36	72	36	36
629	40	20	20	40	20	20	40	20	20
630	40	20	20	40	20	20	40	20	20
631	40	20	20	40	20	20	40	20	20
632	40	20	20	40	20	20	40	20	20
633	147	73.5	73.5	147	73.5	73.5	147	73.5	73.5
634	160	80	80	160	80	80	160	80	80
635	158	79	79	158	79	79	158	79	79
636	160	80	80	160	80	80	160	80	80
637	178	89	89	178	89	89	178	89	89
638	147	73.5	73.5	147	73.5	73.5	147	73.5	73.5
639	147	73.5	73.5	147	73.5	73.5	147	73.5	73.5
640	34			34			34		
641	29	14.5	14.5	29	14.5	14.5	29	14.5	14.5
642	15	7.5	7.5	15	7.5	7.5	15	7.5	7.5
643	108	54	54	108	54	54	108	54	54
644	108	54	54	108	54	54	108	54	54
645	31	15.5	15.5	31	15.5	15.5	31	15.5	15.5
646	31	15.5	15.5	31	15.5	15.5	31	15.5	15.5
647	18	9	9	18	9	9	18	9	9
648	15	7.5	7.5	15	7.5	7.5	15	7.5	7.5
649	0	0	0	0	0	0	0	0	0
650	43	21.5	21.5	43	21.5	21.5	43	21.5	21.5

Table C-1: Continued [pg. 14 of 20]

ID	As Planned Schedule			20-Jun-03			June 24, 2003 (Rescheduled)		
	TF	Owner	KR	TF	Owner	KR	TF	Owner	KR
651	28	14	14	28	14	14	28	14	14
652	28	14	14	28	14	14	28	14	14
653	25	12.5	12.5	25	12.5	12.5	25	12.5	12.5
654	18	9	9	18	9	9	18	9	9
655	33	16.5	16.5	33	16.5	16.5	33	16.5	16.5
656	132	66	66	132	66	66	132	66	66
657	132	66	66	132	66	66	132	66	66
658	132	66	66	132	66	66	132	66	66
659	132	66	66	132	66	66	132	66	66
660	28	14	14	28	14	14	28	14	14
661	41	20.5	20.5	41	20.5	20.5	41	20.5	20.5
662	28	14	14	28	14	14	28	14	14
663	59	29.5	29.5	59	29.5	29.5	59	29.5	29.5
664	41	20.5	20.5	41	20.5	20.5	41	20.5	20.5
665	18	9	9	18	9	9	18	9	9
666	18	9	9	18	9	9	18	9	9
667	114	57	57	114	57	57	114	57	57
668	114	57	57	114	57	57	114	57	57
669	18	9	9	18	9	9	18	9	9
670	66	33	33	66	33	33	66	33	33
671	41	20.5	20.5	41	20.5	20.5	41	20.5	20.5
672	41	20.5	20.5	41	20.5	20.5	41	20.5	20.5
673	41	20.5	20.5	41	20.5	20.5	41	20.5	20.5
674	18	9	9	18	9	9	18	9	9
675	18	9	9	18	9	9	18	9	9
676	18	9	9	18	9	9	18	9	9
677	70	35	35	70	35	35	70	35	35
678	18	9	9	18	9	9	18	9	9
679	64	32	32	64	32	32	64	32	32
680	18	9	9	18	9	9	18	9	9
681	47	23.5	23.5	47	23.5	23.5	47	23.5	23.5
682	72	36	36	72	36	36	72	36	36
683	18	9	9	18	9	9	18	9	9
684	61	30.5	30.5	61	30.5	30.5	61	30.5	30.5
685	72	36	36	72	36	36	72	36	36
686	34	17	17	34	17	17	34	17	17
687	18	9	9	18	9	9	18	9	9
688	71	35.5	35.5	71	35.5	35.5	71	35.5	35.5
689	34	17	17	34	17	17	34	17	17
690	65	32.5	32.5	65	32.5	32.5	65	32.5	32.5
691	34	17	17	34	17	17	34	17	17
692	16			16			16		
693	32	16	16	32	16	16	32	16	16
694	20	10	10	20	10	10	20	10	10
695	46	23	23	46	23	23	46	23	23
696	148	74	74	148	74	74	148	74	74
697	46	23	23	46	23	23	46	23	23
698	31	15.5	15.5	31	15.5	15.5	31	15.5	15.5
699	18	9	9	18	9	9	18	9	9
700	15	7.5	7.5	15	7.5	7.5	15	7.5	7.5

Table C-1: Continued [pg. 15 of 20]

ID	As Planned Schedule			20-Jun-03			June 24, 2003 (Rescheduled)		
	TF	Owner	KR	TF	Owner	KR	TF	Owner	KR
701	0	0	0	0	0	0	0	0	0
702	43	21.5	21.5	43	21.5	21.5	43	21.5	21.5
703	28	14	14	28	14	14	28	14	14
704	28	14	14	28	14	14	28	14	14
705	25	12.5	12.5	25	12.5	12.5	25	12.5	12.5
706	15	7.5	7.5	15	7.5	7.5	15	7.5	7.5
707	46	23	23	46	23	23	46	23	23
708	72	36	36	72	36	36	72	36	36
709	25	12.5	12.5	25	12.5	12.5	25	12.5	12.5
710	16	8	8	16	8	8	16	8	8
711	16	8	8	16	8	8	16	8	8
712	16	8	8	16	8	8	16	8	8
713	148	74	74	148	74	74	148	74	74
714	123	61.5	61.5	123	61.5	61.5	123	61.5	61.5
715	123	61.5	61.5	123	61.5	61.5	123	61.5	61.5
716	65	32.5	32.5	65	32.5	32.5	65	32.5	32.5
717	16	8	8	16	8	8	16	8	8
718	83	41.5	41.5	83	41.5	41.5	83	41.5	41.5
719	83	41.5	41.5	83	41.5	41.5	83	41.5	41.5
720	16	8	8	16	8	8	16	8	8
721	61	30.5	30.5	61	30.5	30.5	61	30.5	30.5
722	60	30	30	60	30	30	60	30	30
723	62	31	31	62	31	31	62	31	31
724	62	31	31	62	31	31	62	31	31
725	62	31	31	62	31	31	62	31	31
726	62	31	31	62	31	31	62	31	31
727	65	32.5	32.5	65	32.5	32.5	65	32.5	32.5
728	65	32.5	32.5	65	32.5	32.5	65	32.5	32.5
729	65	32.5	32.5	65	32.5	32.5	65	32.5	32.5
730	16	8	8	16	8	8	16	8	8
731	16	8	8	16	8	8	16	8	8
732	16	8	8	16	8	8	16	8	8
733	16	8	8	16	8	8	16	8	8
734	16	8	8	16	8	8	16	8	8
735	16	8	8	16	8	8	16	8	8
736	39	19.5	19.5	39	19.5	19.5	39	19.5	19.5
737	47	23.5	23.5	47	23.5	23.5	47	23.5	23.5
738	25	12.5	12.5	25	12.5	12.5	25	12.5	12.5
739	68	34	34	68	34	34	68	34	34
740	27	13.5	13.5	27	13.5	13.5	27	13.5	13.5
741	56	28	28	56	28	28	56	28	28
742	19	9.5	9.5	19	9.5	9.5	19	9.5	9.5
743	25	12.5	12.5	25	12.5	12.5	25	12.5	12.5
744	61	30.5	30.5	61	30.5	30.5	61	30.5	30.5
745	24	12	12	24	12	12	24	12	12
746	45	22.5	22.5	45	22.5	22.5	45	22.5	22.5
747	24	12	12	24	12	12	24	12	12
748	39	19.5	19.5	39	19.5	19.5	39	19.5	19.5
749	16	8	8	16	8	8	16	8	8

Table C-1: Continued [pg. 16 of 20]

ID	As Planned Schedule			20-Jun-03			June 24, 2003 (Rescheduled)		
	TF	Owner	KR	TF	Owner	KR	TF	Owner	KR
750	35			35			35		
751	35	17.5	17.5	35	17.5	17.5	35	17.5	17.5
752	35	17.5	17.5	35	17.5	17.5	35	17.5	17.5
753	35	17.5	17.5	35	17.5	17.5	35	17.5	17.5
754	119	59.5	59.5	119	59.5	59.5	119	59.5	59.5
755	119	59.5	59.5	119	59.5	59.5	119	59.5	59.5
756	119	59.5	59.5	119	59.5	59.5	119	59.5	59.5
757	119	59.5	59.5	119	59.5	59.5	119	59.5	59.5
758	119	59.5	59.5	119	59.5	59.5	119	59.5	59.5
759	120	60	60	120	60	60	120	60	60
760	119	59.5	59.5	119	59.5	59.5	119	59.5	59.5
761	120	60	60	120	60	60	120	60	60
762	124	62	62	124	62	62	124	62	62
763	119	59.5	59.5	119	59.5	59.5	119	59.5	59.5
764	166	83	83	166	83	83	166	83	83
765	119	59.5	59.5	119	59.5	59.5	119	59.5	59.5
766	119	59.5	59.5	119	59.5	59.5	119	59.5	59.5
767	119	59.5	59.5	119	59.5	59.5	119	59.5	59.5
768	152	76	76	152	76	76	152	76	76
769	157	78.5	78.5	157	78.5	78.5	157	78.5	78.5
770	128	64	64	128	64	64	128	64	64
771	152	76	76	152	76	76	152	76	76
772	124	62	62	124	62	62	124	62	62
773	119	59.5	59.5	119	59.5	59.5	119	59.5	59.5
774	119	59.5	59.5	119	59.5	59.5	119	59.5	59.5
775	128	64	64	128	64	64	128	64	64
776	119	59.5	59.5	119	59.5	59.5	119	59.5	59.5
777	18	9	9	18	9	9	18	9	9
778	15	7.5	7.5	15	7.5	7.5	15	7.5	7.5
779	0	0	0	0	0	0	0	0	0
780	43	21.5	21.5	43	21.5	21.5	43	21.5	21.5
781	28	14	14	28	14	14	28	14	14
782	29	14.5	14.5	29	14.5	14.5	29	14.5	14.5
783	26	13	13	26	13	13	26	13	13
784	15	7.5	7.5	15	7.5	7.5	15	7.5	7.5
785	160	80	80	160	80	80	160	80	80
786	163	81.5	81.5	163	81.5	81.5	163	81.5	81.5
787	124	62	62	124	62	62	124	62	62
788	124	62	62	124	62	62	124	62	62
789	131	65.5	65.5	131	65.5	65.5	131	65.5	65.5
790	129	64.5	64.5	129	64.5	64.5	129	64.5	64.5
791	124	62	62	124	62	62	124	62	62
792	131	65.5	65.5	131	65.5	65.5	131	65.5	65.5
793	124	62	62	124	62	62	124	62	62
794	131	65.5	65.5	131	65.5	65.5	131	65.5	65.5
795	124	62	62	124	62	62	124	62	62
796	125	62.5	62.5	125	62.5	62.5	125	62.5	62.5
797	125	62.5	62.5	125	62.5	62.5	125	62.5	62.5
798	124	62	62	124	62	62	124	62	62
799	124	62	62	124	62	62	124	62	62
800	125	62.5	62.5	125	62.5	62.5	125	62.5	62.5
801	119	59.5	59.5	119	59.5	59.5	119	59.5	59.5

Table C-1: Continued [pg. 17 of 20]

ID	As Planned Schedule			20-Jun-03			June 24, 2003 (Rescheduled)		
	TF	Owner	KR	TF	Owner	KR	TF	Owner	KR
802	143			147			146		
803	143	71.5	71.5	147	73.5	73.5	146	73.5	72.5
804	143	71.5	71.5	147	73.5	73.5	146	73.5	72.5
805	120	60	60	120	60	60	120	60	60
806	120	60	60	120	60	60	120	60	60
807	120	60	60	120	60	60	120	60	60
808	123	61.5	61.5	123	61.5	61.5	123	61.5	61.5
809	133	66.5	66.5	133	66.5	66.5	133	66.5	66.5
810	120	60	60	120	60	60	120	60	60
811	120	60	60	120	60	60	120	60	60
812	120	60	60	120	60	60	120	60	60
813	120	60	60	120	60	60	120	60	60
814	120	60	60	120	60	60	120	60	60
815	120	60	60	120	60	60	120	60	60
816	204	102	102	204	102	102	204	102	102
817	120	60	60	120	60	60	120	60	60
818	120	60	60	120	60	60	120	60	60
819	90			90			90		
820	90	45	45	90	45	45	90	45	45
821	90	45	45	90	45	45	90	45	45
822	90	45	45	90	45	45	90	45	45
823	90	45	45	90	45	45	90	45	45
824	94	47	47	94	47	47	94	47	47
825	90	45	45	90	45	45	90	45	45
826	90	45	45	90	45	45	90	45	45
827	94	47	47	94	47	47	94	47	47
828	90	45	45	90	45	45	90	45	45
829	90	45	45	90	45	45	90	45	45
830	90	45	45	90	45	45	90	45	45
831	90	45	45	90	45	45	90	45	45
832	90	45	45	90	45	45	90	45	45
833	91	45.5	45.5	91	45.5	45.5	91	45.5	45.5
834	110	55	55	110	55	55	110	55	55
835	91			91			91		
836	91	45.5	45.5	91	45.5	45.5	91	45.5	45.5
837	109	54.5	54.5	109	54.5	54.5	109	54.5	54.5
838	91	45.5	45.5	91	45.5	45.5	91	45.5	45.5
839	91	45.5	45.5	91	45.5	45.5	91	45.5	45.5
840	233	116.5	116.5	233	116.5	116.5	233	116.5	116.5
841	233	116.5	116.5	233	116.5	116.5	233	116.5	116.5
842	220	110	110	220	110	110	220	110	110
843	25			25			25		
844	25	12.5	12.5	25	12.5	12.5	25	12.5	12.5
845	25	12.5	12.5	25	12.5	12.5	25	12.5	12.5
846	25	12.5	12.5	25	12.5	12.5	25	12.5	12.5
847	25	12.5	12.5	25	12.5	12.5	25	12.5	12.5
848	79	39.5	39.5	79	39.5	39.5	79	39.5	39.5
849	81	40.5	40.5	81	40.5	40.5	81	40.5	40.5
850	90	45	45	90	45	45	90	45	45

Table C-1: Continued [pg. 18 of 20]

ID	As Planned Schedule			20-Jun-03			June 24, 2003 (Rescheduled)		
	TF	Owner	KR	TF	Owner	KR	TF	Owner	KR
851	93	46.5	46.5	93	46.5	46.5	93	46.5	46.5
852	40	20	20	40	20	20	40	20	20
853	40	20	20	40	20	20	40	20	20
854	40	20	20	40	20	20	40	20	20
855	40	20	20	40	20	20	40	20	20
856	40	20	20	40	20	20	40	20	20
857	108	54	54	108	54	54	108	54	54
858	103	51.5	51.5	103	51.5	51.5	103	51.5	51.5
859	103	51.5	51.5	103	51.5	51.5	103	51.5	51.5
860	103	51.5	51.5	103	51.5	51.5	103	51.5	51.5
861	25			25			25		
862	25	12.5	12.5	25	12.5	12.5	25	12.5	12.5
863	90	45	45	90	45	45	90	45	45
864	90	45	45	90	45	45	90	45	45
865	18	9	9	18	9	9	18	9	9
866	15	7.5	7.5	15	7.5	7.5	15	7.5	7.5
867	0	0	0	0	0	0	0	0	0
868	43	21.5	21.5	43	21.5	21.5	43	21.5	21.5
869	28	14	14	28	14	14	28	14	14
870	27	13.5	13.5	27	13.5	13.5	27	13.5	13.5
871	24	12	12	24	12	12	24	12	12
872	13	6.5	6.5	13	6.5	6.5	13	6.5	6.5
873	25	12.5	12.5	25	12.5	12.5	25	12.5	12.5
874	25	12.5	12.5	25	12.5	12.5	25	12.5	12.5
875	95	47.5	47.5	95	47.5	47.5	95	47.5	47.5
876	54	27	27	54	27	27	54	27	27
877	47	23.5	23.5	47	23.5	23.5	47	23.5	23.5
878	44	22	22	44	22	22	44	22	22
879	47	23.5	23.5	47	23.5	23.5	47	23.5	23.5
880	44	22	22	44	22	22	44	22	22
881	47	23.5	23.5	47	23.5	23.5	47	23.5	23.5
882	50	25	25	50	25	25	50	25	25
883	92	46	46	92	46	46	92	46	46
884	50	25	25	50	25	25	50	25	25
885	53	26.5	26.5	53	26.5	26.5	53	26.5	26.5
886	50	25	25	50	25	25	50	25	25
887	44	22	22	44	22	22	44	22	22
888	44	22	22	44	22	22	44	22	22
889	47	23.5	23.5	47	23.5	23.5	47	23.5	23.5
890	47	23.5	23.5	47	23.5	23.5	47	23.5	23.5
891	47	23.5	23.5	47	23.5	23.5	47	23.5	23.5
892	44	22	22	44	22	22	44	22	22
893	77	38.5	38.5	77	38.5	38.5	77	38.5	38.5
894	70	35	35	70	35	35	70	35	35
895	55	27.5	27.5	55	27.5	27.5	55	27.5	27.5
896	91	45.5	45.5	91	45.5	45.5	91	45.5	45.5
897	76	38	38	76	38	38	76	38	38
898	70	35	35	70	35	35	70	35	35
899	18	9	9	18	9	9	18	9	9
900	29	14.5	14.5	29	14.5	14.5	29	14.5	14.5

Table C-1: Continued [pg. 19 of 20]

ID	As Planned Schedule			20-Jun-03			June 24, 2003 (Rescheduled)		
	TF	Owner	KR	TF	Owner	KR	TF	Owner	KR
901	75	37.5	37.5	75	37.5	37.5	75	37.5	37.5
902	29	14.5	14.5	29	14.5	14.5	29	14.5	14.5
903	19			19			19		
904	30	15	15	30	15	15	30	15	15
905	18	9	9	18	9	9	18	9	9
906	15	7.5	7.5	15	7.5	7.5	15	7.5	7.5
907	0	0	0	0	0	0	0	0	0
908	43	21.5	21.5	43	21.5	21.5	43	21.5	21.5
909	28	14	14	28	14	14	28	14	14
910	18	9	9	18	9	9	18	9	9
911	15	7.5	7.5	15	7.5	7.5	15	7.5	7.5
912	10	5	5	10	5	5	10	5	5
913	33	16.5	16.5	33	16.5	16.5	33	16.5	16.5
914	25	12.5	12.5	25	12.5	12.5	25	12.5	12.5
915	63	31.5	31.5	63	31.5	31.5	63	31.5	31.5
916	26	13	13	26	13	13	26	13	13
917	15	7.5	7.5	15	7.5	7.5	15	7.5	7.5
918	18	9	9	18	9	9	18	9	9
919	10	5	5	10	5	5	10	5	5
920	10	5	5	10	5	5	10	5	5
921	55	27.5	27.5	55	27.5	27.5	55	27.5	27.5
922	10	5	5	10	5	5	10	5	5
923	76	38	38	76	38	38	76	38	38
924	39	19.5	19.5	39	19.5	19.5	39	19.5	19.5
925	41	20.5	20.5	41	20.5	20.5	41	20.5	20.5
926	10	5	5	10	5	5	10	5	5
927	10	5	5	10	5	5	10	5	5
928	10	5	5	10	5	5	10	5	5
929	10	5	5	10	5	5	10	5	5
930	55	27.5	27.5	55	27.5	27.5	55	27.5	27.5
931	55	27.5	27.5	55	27.5	27.5	55	27.5	27.5
932	55	27.5	27.5	55	27.5	27.5	55	27.5	27.5
933	10	5	5	10	5	5	10	5	5
934	36	18	18	36	18	18	36	18	18
935	19	9.5	9.5	19	9.5	9.5	19	9.5	9.5
936	45	22.5	22.5	45	22.5	22.5	45	22.5	22.5
937	65	32.5	32.5	65	32.5	32.5	65	32.5	32.5
938	31	15.5	15.5	31	15.5	15.5	31	15.5	15.5
939	19	9.5	9.5	19	9.5	9.5	19	9.5	9.5
940	10	5	5	10	5	5	10	5	5
941	20	10	10	20	10	10	20	10	10
942	20	10	10	20	10	10	20	10	10
943	19	9.5	9.5	19	9.5	9.5	19	9.5	9.5
944	0			0			0		
945	37	18.5	18.5	37	18.5	18.5	37	18.5	18.5
946	23	11.5	11.5	23	11.5	11.5	23	11.5	11.5
947	20	10	10	20	10	10	20	10	10
948	0	0	0	0	0	0	0	0	0
949	43	21.5	21.5	43	21.5	21.5	43	21.5	21.5
950	28	14	14	28	14	14	28	14	14

Table C-1: Continued [pg. 20 of 20]

ID	As Planned Schedule			20-Jun-03			June 24, 2003 (Rescheduled)		
	TF	Owner	KR	TF	Owner	KR	TF	Owner	KR
951	23	11.5	11.5	23	11.5	11.5	23	11.5	11.5
952	20	10	10	20	10	10	20	10	10
953	0	0	0	0	0	0	0	0	0
954	37	18.5	18.5	37	18.5	18.5	37	18.5	18.5
955	25	12.5	12.5	25	12.5	12.5	25	12.5	12.5
956	61	30.5	30.5	61	30.5	30.5	61	30.5	30.5
957	25	12.5	12.5	25	12.5	12.5	25	12.5	12.5
958	24	12	12	24	12	12	24	12	12
959	6	3	3	6	3	3	6	3	3
960	20	10	10	20	10	10	20	10	10
961	9	4.5	4.5	9	4.5	4.5	9	4.5	4.5
962	0	0	0	0	0	0	0	0	0
963	23	11.5	11.5	23	11.5	11.5	23	11.5	11.5
964	0	0	0	0	0	0	0	0	0
965	45	22.5	22.5	45	22.5	22.5	45	22.5	22.5
966	0	0	0	0	0	0	0	0	0
967	0	0	0	0	0	0	0	0	0
968	0	0	0	0	0	0	0	0	0
969	2	1	1	2	1	1	2	1	1
970	3	1.5	1.5	3	1.5	1.5	3	1.5	1.5
971	3	1.5	1.5	3	1.5	1.5	3	1.5	1.5
972	0	0	0	0	0	0	0	0	0
973	0	0	0	0	0	0	0	0	0
974	0	0	0	0	0	0	0	0	0
975	45	22.5	22.5	45	22.5	22.5	45	22.5	22.5
976	45	22.5	22.5	45	22.5	22.5	45	22.5	22.5
977	45	22.5	22.5	45	22.5	22.5	45	22.5	22.5
978	0	0	0	0	0	0	0	0	0
979	26	13	13	26	13	13	26	13	13
980	0	0	0	0	0	0	0	0	0
981	42	21	21	42	21	21	42	21	21
982	25	12.5	12.5	25	12.5	12.5	25	12.5	12.5
983	23	11.5	11.5	23	11.5	11.5	23	11.5	11.5
984	0	0	0	0	0	0	0	0	0
985	8	4	4	8	4	4	8	4	4
986	0	0	0	0	0	0	0	0	0
987	5	2.5	2.5	5	2.5	2.5	5	2.5	2.5
988	6	3	3	6	3	3	6	3	3
989	0	0	0	0	0	0	0	0	0
990	23	11.5	11.5	23	11.5	11.5	23	11.5	11.5
991	0	0	0	0	0	0	0	0	0
992	0	0	0	0	0	0	0	0	0
993	0	0	0	0	0	0	0	0	0