

COSMOGRAPHIC ORIGINS FOR A NEW CLASSICISM

This thesis submitted to the graduate faculty of the Virginia Polytechnic Institute and State University in partial fulfillment of the requirements for the degree of

Master of Architecture

Steven L. Pliam

Approved by:

Dr. Humberto Rodriguez-Camilloni

Frank Weiner

William Galloway

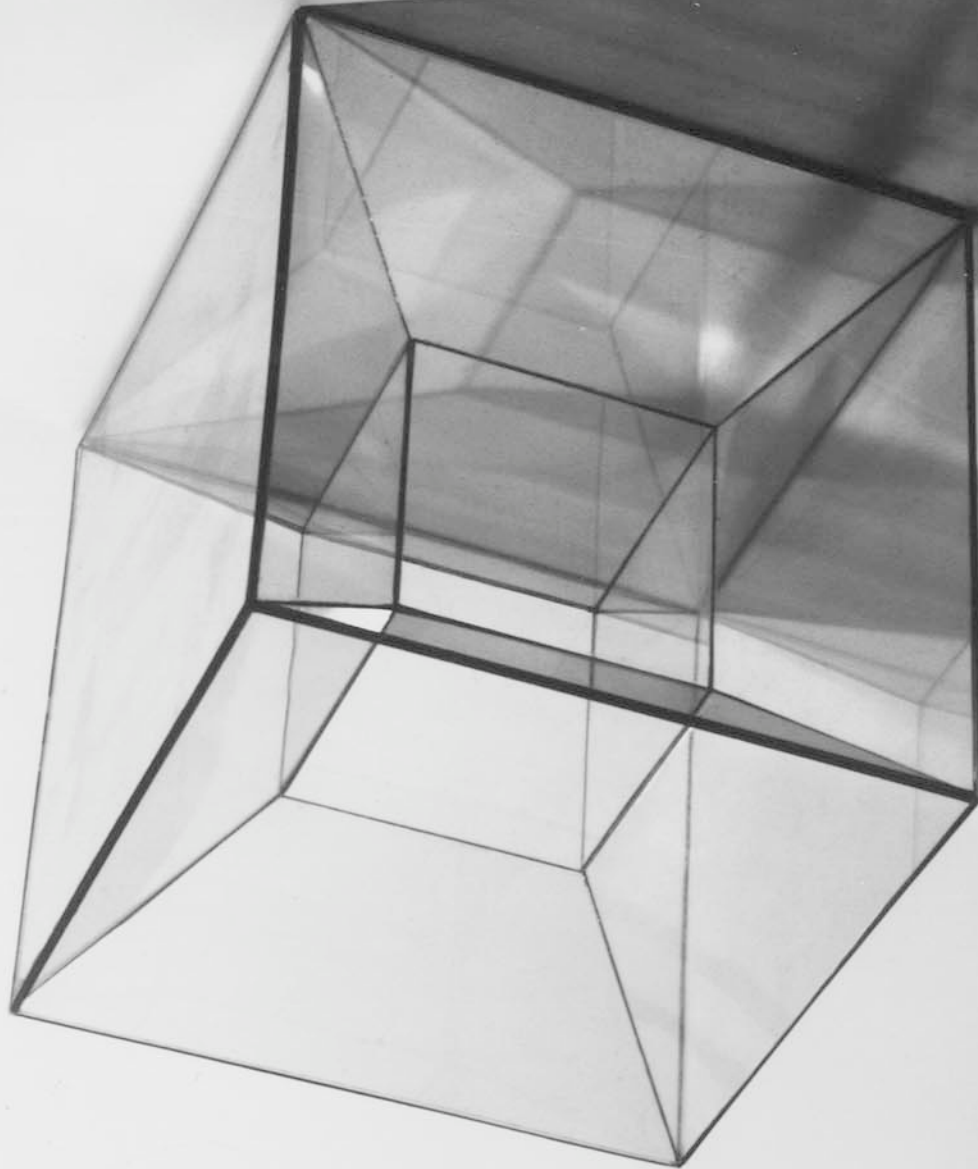

COSMOGRAPHIC ORIGINS FOR A NEW CLASSICISM
Steven L. Pliam

ABSTRACT

The spirit of the Latin 'classicus' as a broad ideology has in one sense existed through every age of modern human history. It could begin to be described as an attitude that is resistant to sudden change and is not interested in dramatic breaks with tradition or the avant garde. It embraces the methodical evolution of aesthetic and artistic values that are connected at their origin to a cosmography which is conceived within every given age. This large-scale conception of existence which encompasses all of what is known in the cosmos is a primary manifestation of every culture.

Several systems of ideas are given by 20th century theoretical physics. They are the foundation of our science and provide an explicit basis for all branches of scientific endeavor. Taken as a whole, they constitute the current understanding of our universe—our world. What emerges from the ideas given by relativity theory, quantum physics, string theory, and the mathematics of astro-physics is a profound and far reaching cosmography resembling nothing like that of the Renaissance or of classical Greece. Non-Euclidean geometry and the math of higher dimensional space begin to break free of their abstract character as these symbolic disciplines now inform and reconcile the reality of cosmic space.

It is therefore appropriate to understand the cosmography of today in relation to the new science paradigm. As cosmic space and conceptual space have always been intimately connected in architecture of the classical spirit, this new cosmography then becomes a viable basis for reestablishing a classical expression.

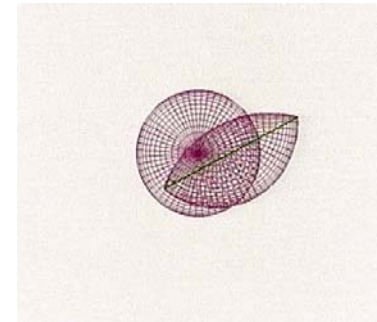
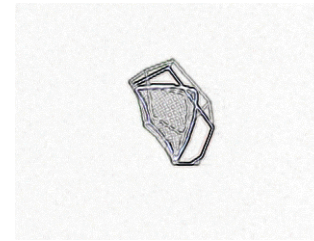

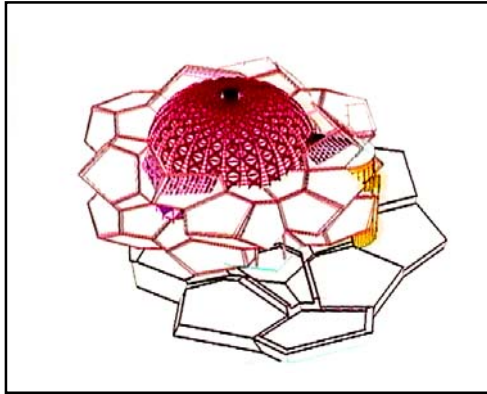

Acknowledgments

I wish to give the greatest acknowledgment and unfeigning gratitude to my beloved mother
Podi Ann Blatherwick-Pliam-Stockberger
for her consistent and tenacious lifetime commitment to my happiness and success.

My sincere gratitude and thanks to

My father
Michael Brian Pliam
for his encouragement and wisdom

My significant one
Anjali Bollamma Ganapathy
for being a constant sounding board without sounding bored and her foot to give the last kick

My friend
Henry Brawner
for his input and output and astounding devotion to assisting my development and defense

and finally to

My committee:
Dr. Humberto Rodriguez-Camilloni
Professor Frank Weiner
Professor William Galloway
for their patience, support, and criticism

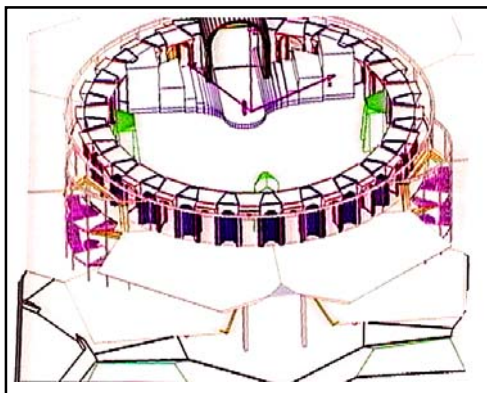
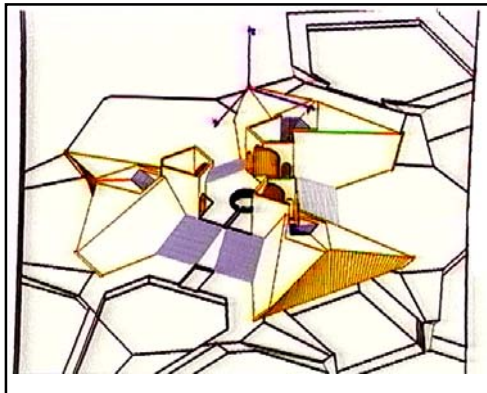

CONTENTS

- 1 **Historical Chronology in Context**
 - Middle Ages
 - Renaissance
 - Baroque
 - Modern

- 13 **Theoretical Foundations**
 - Architecture
 - Platonic Bodies
 - The Hypercube
 - The Hyperdodecahedron
 - Spherical Space

- 31 **Lyceum Project**

- 49 **Bibliography**

HISTORICAL CHRONOLOGY IN CONTEXT



Bayeux Tapestry. Detail. c.1073-83

The etymology of the word "classical," and even "classic" for that matter, reveals that these words stem from the Latin word "classicus" which means: of or relating to the classes of people, and especially most often to the first class or the highest echelon of society. While at first that might smack of elitism, it is vital to understand that when the Romans referred to the Greek 'classici' (the members of the classicus), they were specifically referring to the literati, poets, and philosophers, those who were involved with and formed the first academy, the Aristotelian lyceum. They were not necessarily referring to those with political power or wealth as might be inferred in current times. As much as language and particular terms evolve, this important connection with academia is carried through the centuries in the evolving traditions of classical form. In the Middle Ages, a member of the classicus seems to have been almost exclusively taken to mean an academic or learned writer or artist. Thus, without a doubt, this has been one of the most important defining characteristics of works of music, architecture, and art belonging to the classical canon through the ages to the present time.

Concepts of space, in a given culture, are inherent in its artistic expressions. From the Egyptian pyramids to the Greek temples the designs are strongly linked to the deities. Vitruvius outlines the principles for how an architect should design the temples in his treatise: "The temples of Minerva, Mars, and Hercules, will be Doric, since the virile strength of these gods makes daintiness entirely inappropriate to their houses. In temples to Venus, Flora, Proserpine, Spring-Water, and the Nymphs, the Corinthian order will be found to have peculiar significance, because these are delicate divinities and so its rather slender outlines, its flowers, leaves, and ornamental volutes will lend propriety where it is due." The viewpoint of the omnipresent Deity in the Byzantine world-view is expressed in the flattened space of drawings and paintings of the time. Even the comet up in the sky, observed by the English soldiers in the middle-aged tapestry (opposite), is given an extremely two-dimensional treatment.

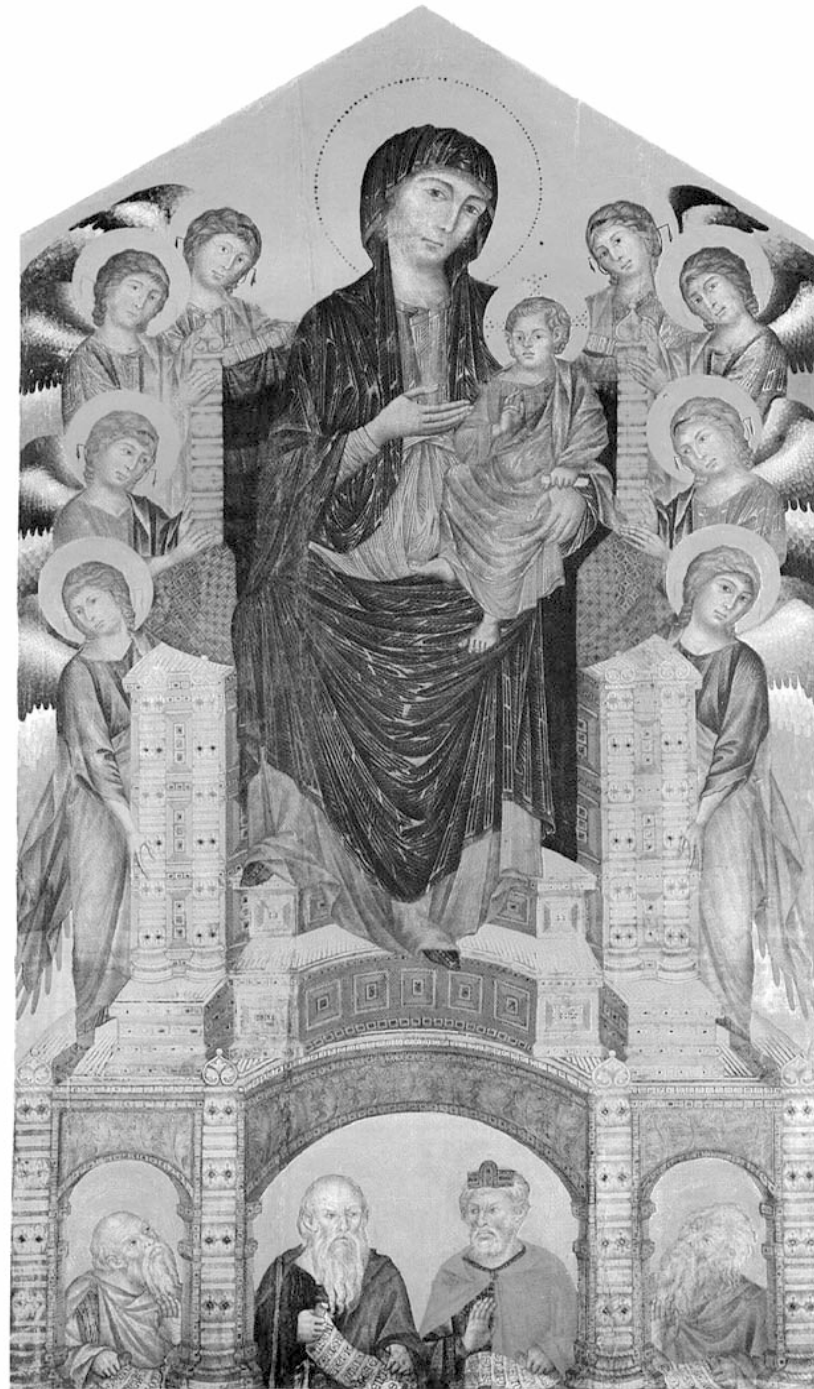

CIMABUE. Enthroned Madonna and Child. C.1280

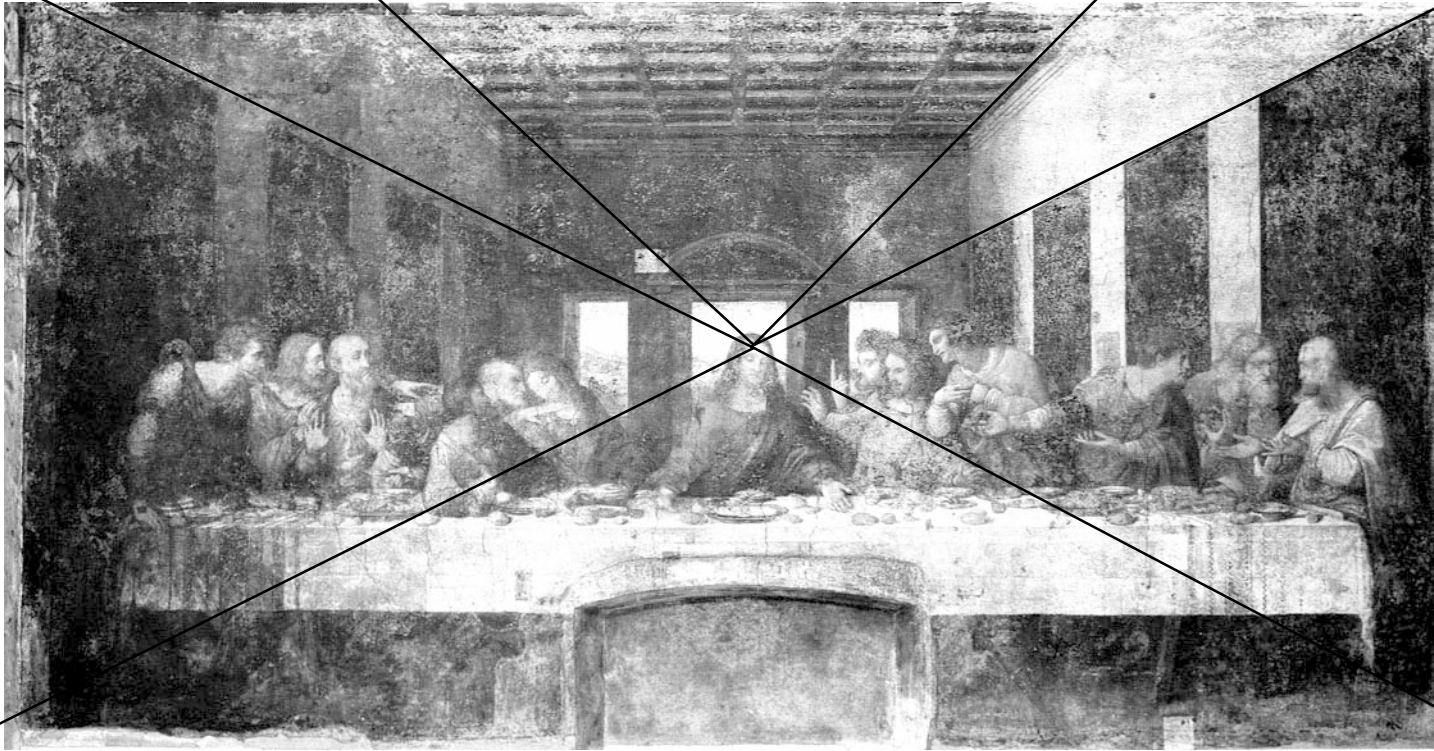

LEONARDO DA VINCI. The Last Supper. c.1495-98



GIORGIO VASARI. Uffizi, Florence. c.1560-80

The gothic cathedrals of Europe with the advent of buttresses, thus allowing the walls to open up and let the light of the heavens penetrate to the inside, establishes that canonical link between the cosmography of the time and the architectural design. The Renaissance brought the inception of the modern notion of space into the cosmological picture. As Sigfried Giedion points out, the "new perspective" provided a new conception of space which greatly influenced architectural space. Suddenly, depth "into" the two-dimensional page imparts a larger more sophisticated sense of space.

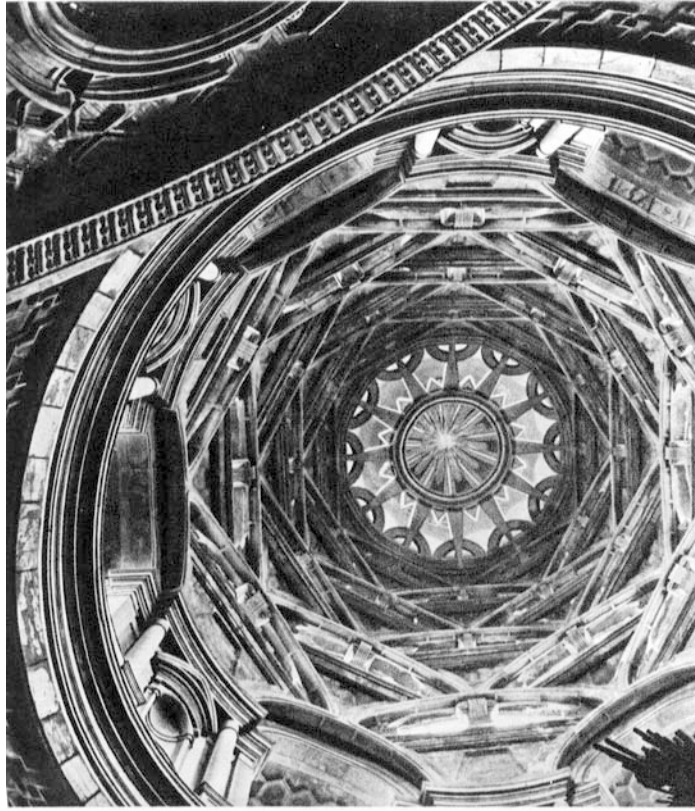

GUARINO GUARINI. Chapel of the Holy Shroud.. c.1668-94

Conceptual space eventually evolves beyond the Renaissance perspective as cosmography begins to assume a more pervasive role in the expression and design of architectural space. With the baroque conception of infinity and infinite space, conceptual space becomes embodied in architectural space with such examples as the great axis of Versailles, the ceiling frescos and domes of baroque churches, and other architecture of that time.



GIOVANNI BATTISTA GAULLI. Triumph of the Name of Jesus. Fresco. c.1672-85

The Medici Chapel in Florence is a most illustrative example of the profound influence of a new spatial concept on the design of architecture. Michelangelo's cupola has four windows just below the cupola which are exactly like the other windows in the chapel except for one peculiar feature: they are slightly tapered so that the distortion gives an exaggerated sense of perspective and spatial depth. This is literally form following, and completely following through, an intellectualized spatial concept.



MICHELANGELO. Dome of the Medici Chapel at San Lorenzo. c.1519-34

The scientist does not study Nature because it is useful; he studies it because he delights in it, and he delights in it because it is beautiful. If Nature were not beautiful, it would not be worth knowing, and if Nature were not worth knowing, life would not be worth living.

--Henri Poincaré

If architecture must be oriented to nature and culture, then it also must have a larger orientation: the universe as a whole. Architecture has always had some cosmic dimension in traditional cultures. In India, Egypt, Greece, Japan, and in the West throughout the Renaissance, architects inscribed the cosmos in their buildings, oriented their structures to the propitious points of the universe and represented it in the details. Today architecture must also do these things, as well as go beyond this to our contemporary view; that is, cosmogenesis...Why should one look to the new sciences for a lead? Partly because they are leading in a better direction—towards a more creative world view than that of Modernism—and partly because they are true. Furthermore, architecture, whether ancient Egyptian, Christian or Modern, has always represented a prevailing world view, and to be credible today must be engaged with science at its most advanced level.

--Charles Jencks

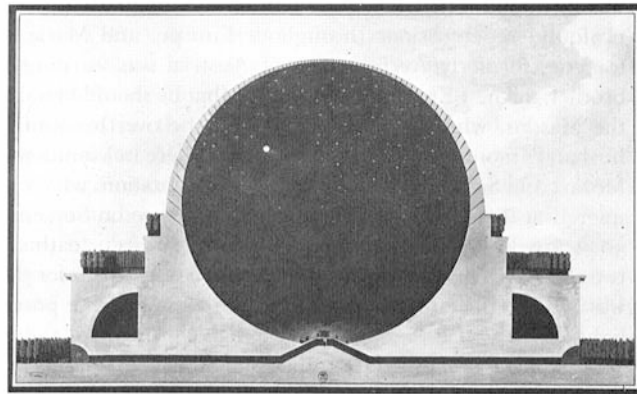
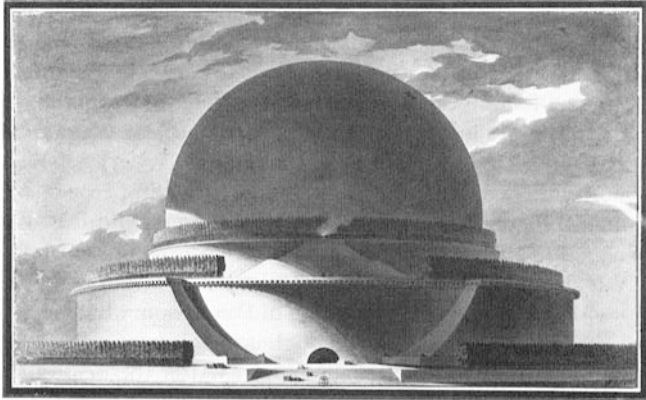

ETIENNE-LOUIS BOULLEE, Cenotaph for Isaac Newton. c.1784



CHARLES CORREA, Inter-University Center of Astronomy and Astrophysics, Pune, India, c.1993

...the natural laws satisfying the demands of the theory of relativity assume mathematical forms, in which the time coordinate plays exactly the same role as the three space coordinates. Formally, these four coordinates correspond exactly to the three space coordinates in Euclidean geometry. It must be clear even to the non-mathematician that, as a consequence of this purely formal addition to our knowledge, the theory perforce gained clearness in no mean measure.

Since there exist in this four-dimensional structure no longer any sections which represent "now" objectively, the concepts of happening and becoming are indeed not completely suspended, but yet complicated. It appears therefore more natural to think of physical reality as a four-dimensional existence, instead of, as hitherto, the evolution of a three-dimensional existence.

A four-dimensional continuum described by the coordinates x_1, x_2, x_3, x_4 , was called "world" by Minkowski, who also termed a point-event a "world-point." From a "happening" in three-dimensional space, physics becomes, as it were, an "existence" in the four-dimensional "world." ...We can regard Minkowski's "world" in a formal manner as a four-dimensional Euclidean space.

Albert Einstein, Relativity: the special and the general theory, 1916

In the 20th century, complexity science is a cornerstone of our culture. It gives a new and higher understanding of space. The influence on art can already be observed in the cubist works of the early part of the century. Picasso shows a multiple view of a woman's face in the following painting. Conceptually, the viewpoint of the observer is changing. The idea of all possible views of an object being experienced at once is proposed by relativity theory and is a consequence of a higher-dimensional space. Analogously, as we can see all sides of a square from up above it, so can all sides of a cube be seen from "up above" it in the fourth dimension.

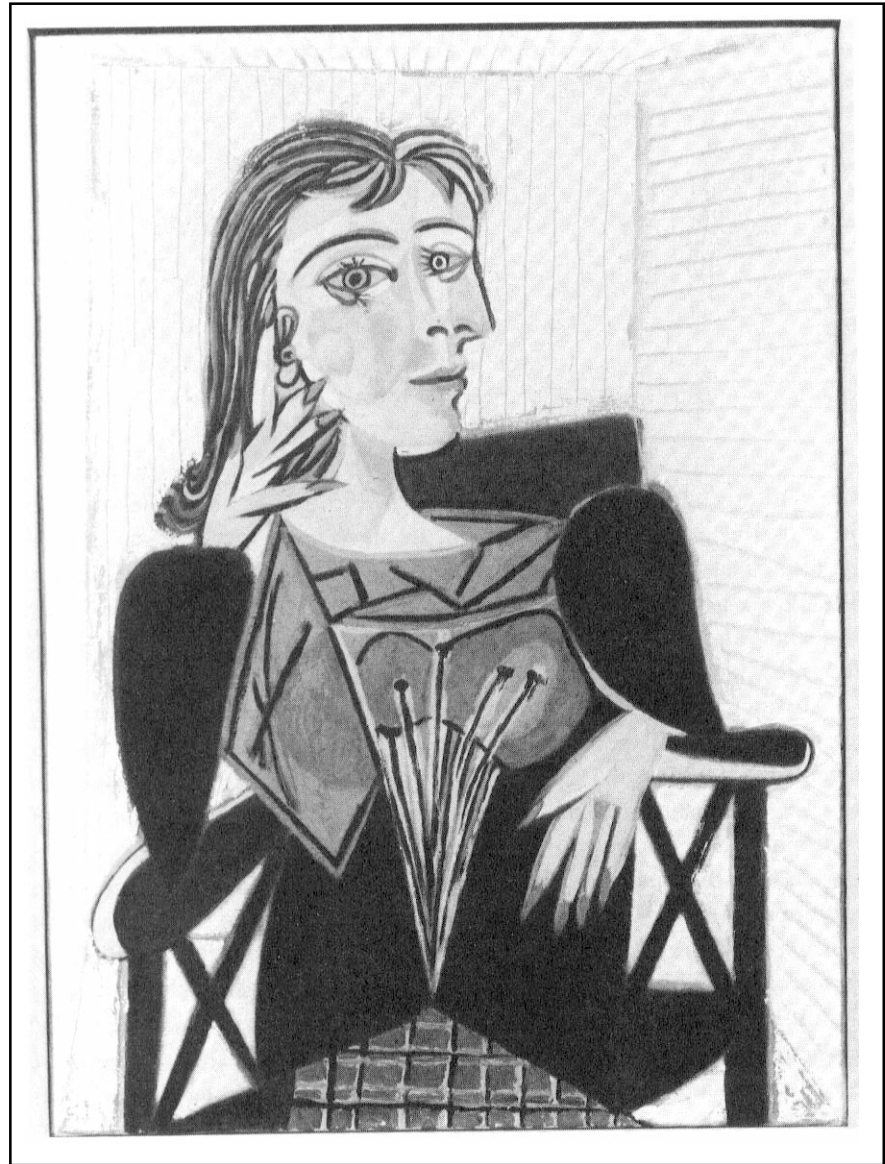

PABLO PICASSO. Woman in an Armchair. c.1913

THEORETICAL FOUNDATIONS

Scientific Space as a cosmography
for a new classicism

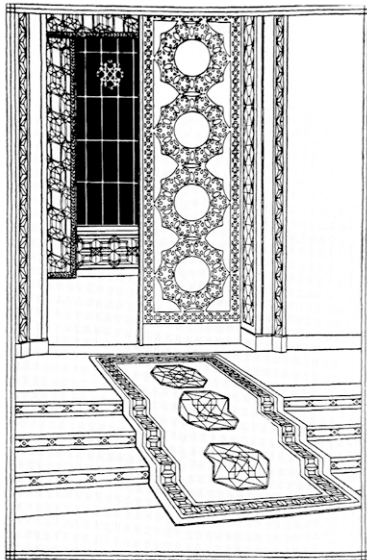

CLAUDE BRAGDON. Projective Ornament. c.1915

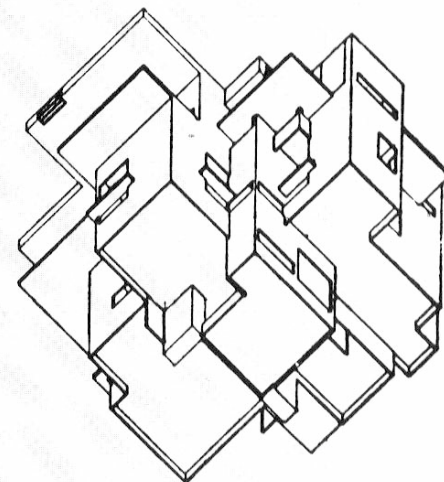
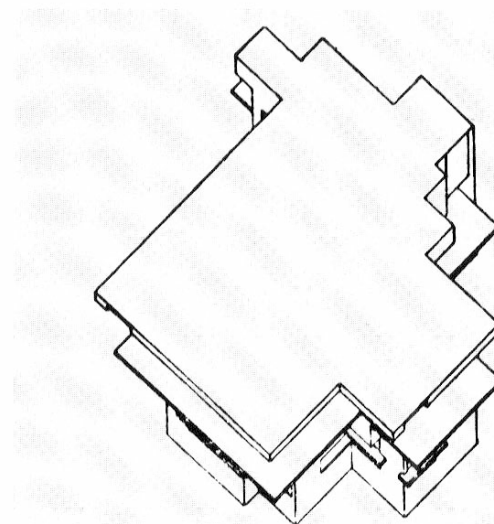
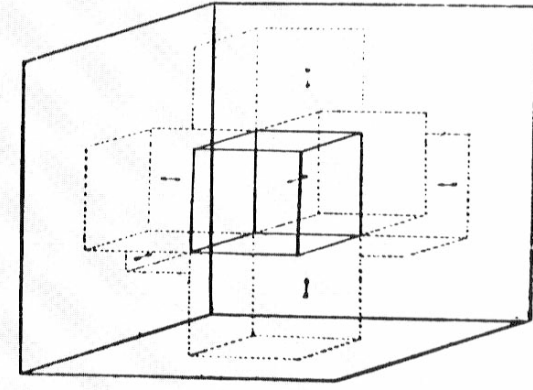
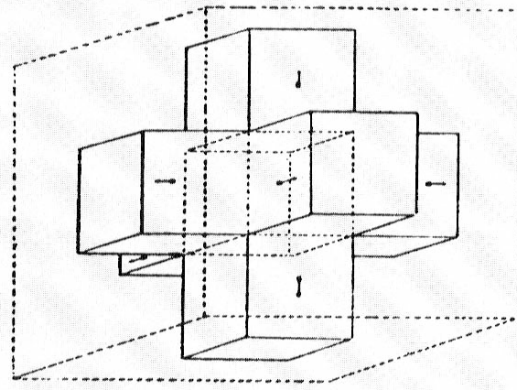
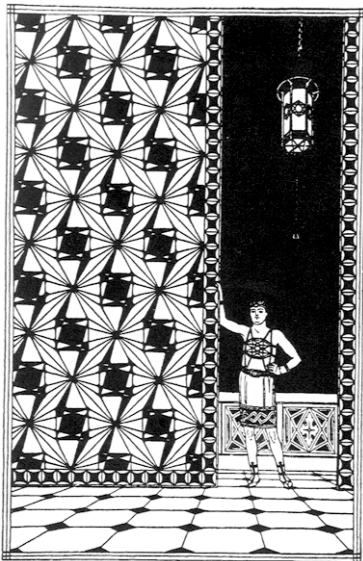

THEO VAN DOESBURG. Hypercube House. c.1923. from Van Doesburg, "L'Evolution de l'architecture moderne en Hollande," L'Architecture Vivante, 1925, p.19.

Higher spatial concepts have had some influence in the architecture of the early 20th century. While this influence is not nearly as widespread as can be observed in the fine arts, Buckminster Fuller, Claude Bragdon, and Theo van Doesburg among few others have worked with higher dimensional concepts in their designs.

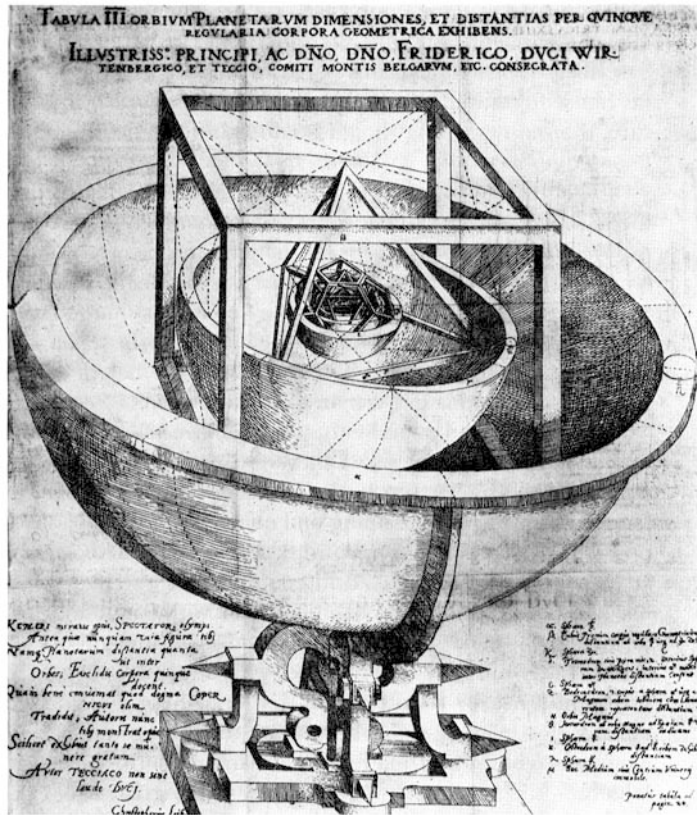

JOHANNES KEPLER. *Mysterium Cosmographicum*. Frontpiece. c.1596

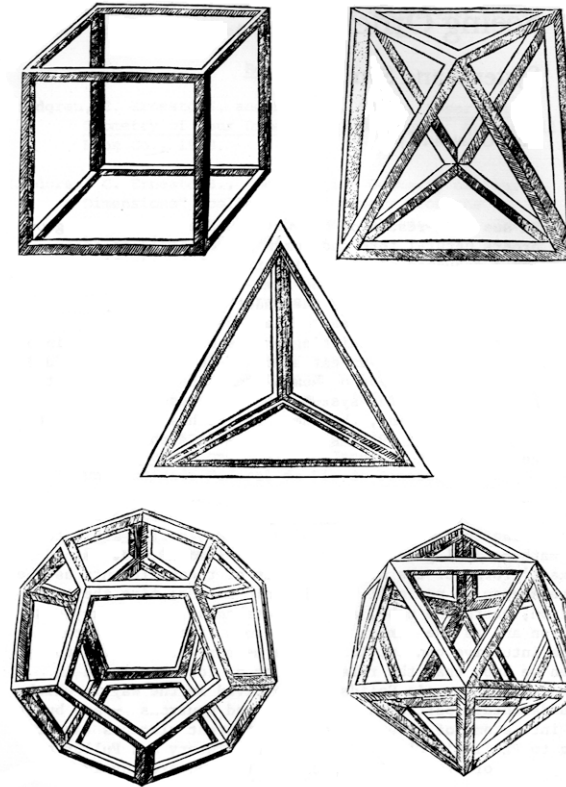

JOHANNES KEPLER. *Mysterium Cosmographicum*. Platonic Solids. c.1596

The Platonic solids have retained an almost sacred status through the centuries. Fifteen centuries after Pythagoras, Kepler devised an entire system of orbits and structure for the universe based on the regular solids as the fundamental components of that system. A logical starting point for the study of higher-dimensional space would be the study of the polytopes, that is, the higher-dimensional regular solids.

...Let us assign the cube to earth; for it is the most immobile of the four bodies... while similarly we assign the least mobile of the other figures [the icosahedron] to water, the most mobile [the tetrahedron] to fire, and the intermediate [the octahedron] to air. And again we assign the smallest figure to fire, the largest to water, the intermediate to air; the sharpest to fire, the next sharpest to air, and the least sharp to water.... We must of course think of the individual units of all four bodies as being too small to be visible, and only becoming visible when massed together in large numbers; and we must assume that the god duly adjusted the proportions between their numbers, their movements, and their other qualities and brought them in every way to exactest perfection permitted by the willing consent of necessity.

There still remained a fifth construction [the dodecahedron], which the god used for embroidering the constellations on the whole heaven.

--Plato, *Timaeus*

Pythagoras, seeing that there are 5 solid figures... said that the Sphere of the Universe arose from the dodecahedron.

--Aetius, *Placita* (Scholium on Euclid's Fourth book)

To "see" is to integrate thought with visual input to the mind. One cannot see without imparting an interpretation or a conceptual bias to what is seen. This idea is very important in the apprehension of higher spatial conceptions. The stereogram illustrates this point very well. A viewer can look upon the two cubes to the right as a simple 2-dimensional drawing. An alternative way of seeing these two cubes is to cross the eyes so that they merge together to form a single 3-dimensional cube. The viewer can actually see a 3-dimensional cube as if it exists in a virtual 3-dimensional space, because the viewer's horopter (a surface formed by the set of all points at a given focal distance) can scan through this virtual object to give us a sense of parallax which is how we perceive depth. Similarly, the viewer can cross the eyes to fuse the 2 hypercubes to form not only a 3-dimensional object, but a 4-dimensional hypercube. It can literally be "seen" as an object existing in 4-dimensional space, because as the viewer rotates the page right and left while having fused the 2 drawings with the eyes, there is another dimension of parallax which allows the viewer to experience a 3-dimensional horopter scanning through 4-dimensional space. Thus, how one sees a phenomena largely depends on their conceptual knowledge of it.

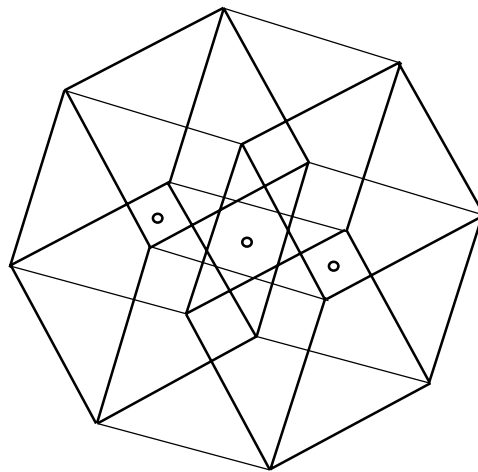
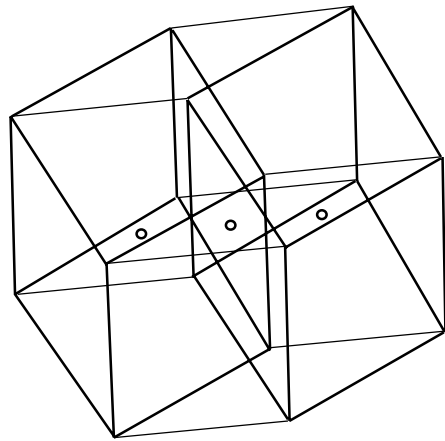
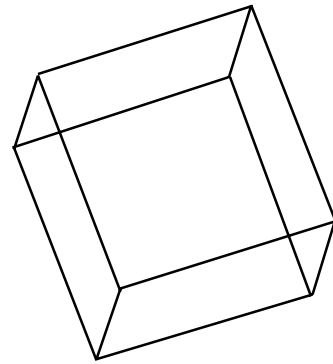
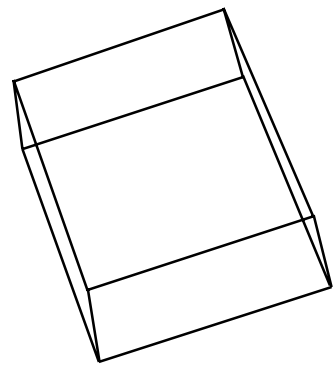

The new computer modeling technology is a great and powerful tool for exploring the structure and properties of the regular polytopes. It also allows one to perform boolean operations on the various components of these hyper-solids. The following series is a study of the hypercube as it is decomposed and its interiors are investigated through the various boolean manipulations of union, subtraction, and intersection.

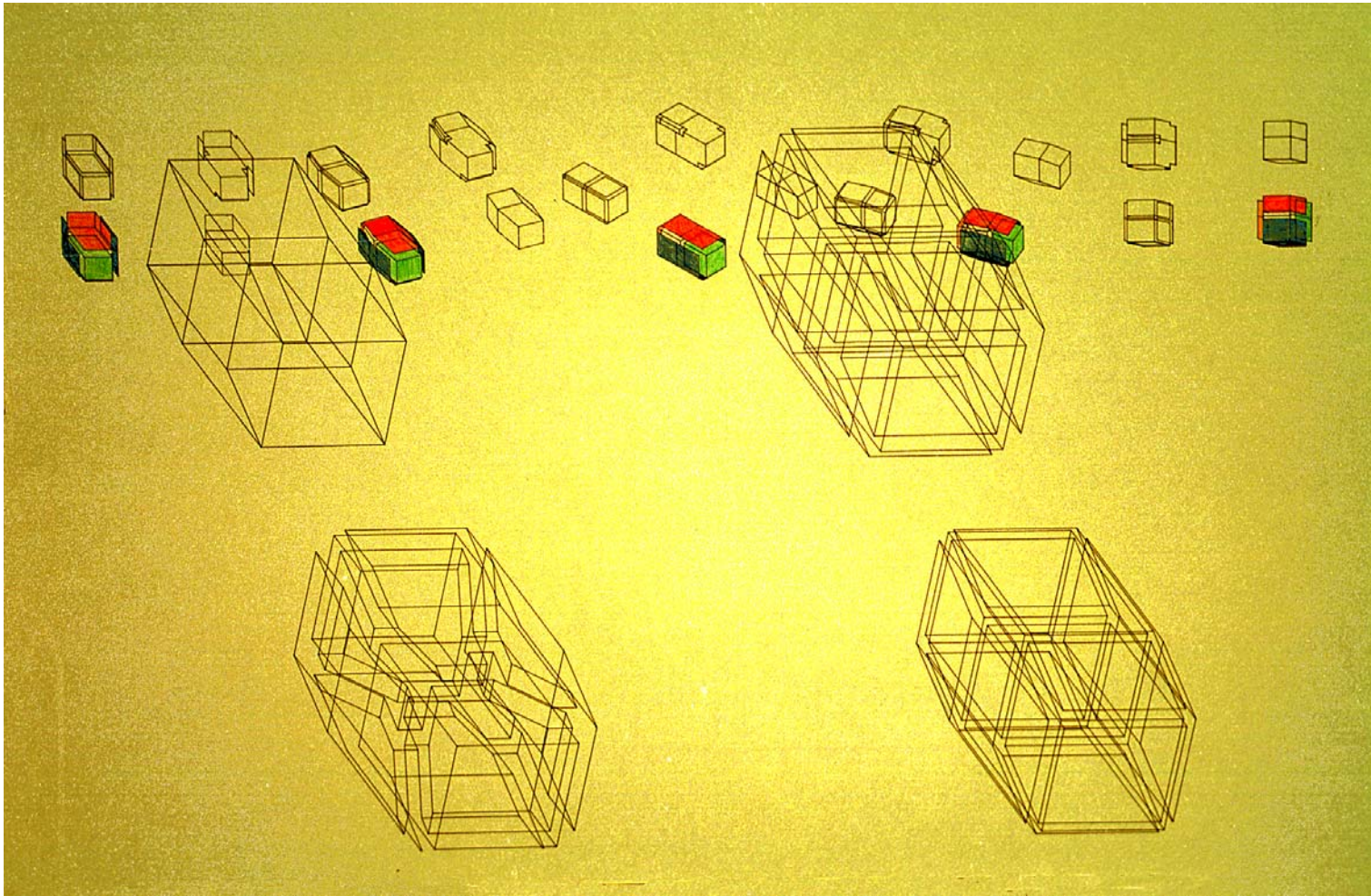

The decomposition of the hypercube to the right shows all eight of the cubes that form boundries between the interior hyperspace and the exterior hyperspace just as the six squares of a cube enclose an interior 3-dimensional space. The accompanying drawings are of a partially exploded hypercube which is then fused together by a succession of boolean union operations.

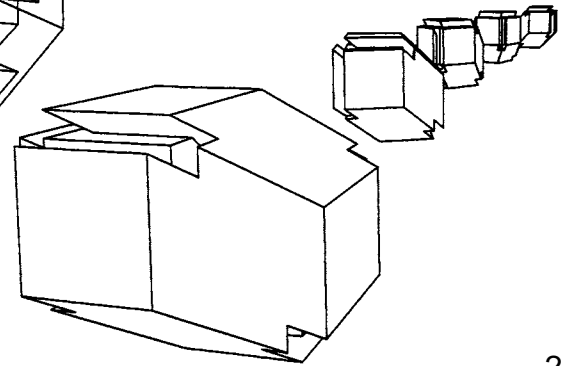
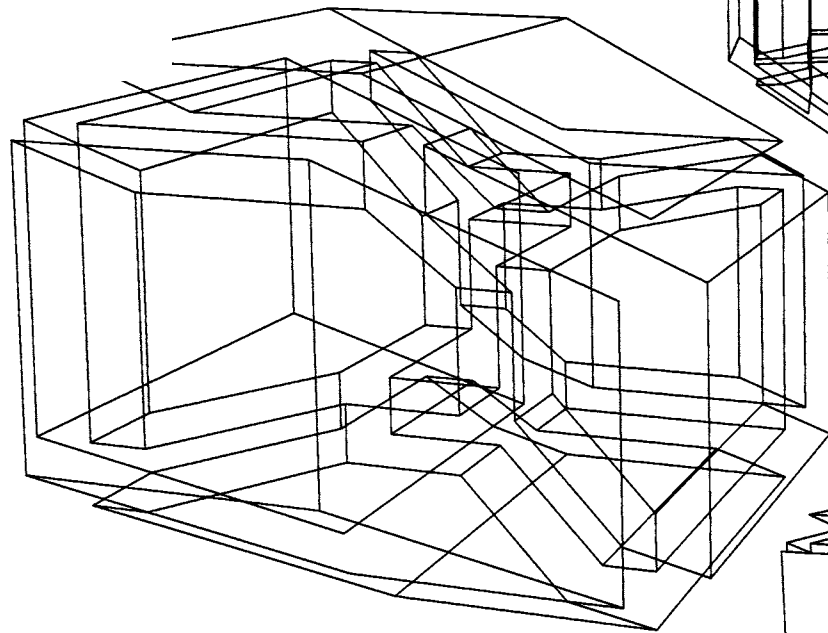
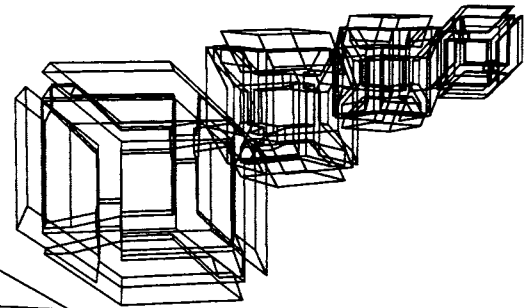
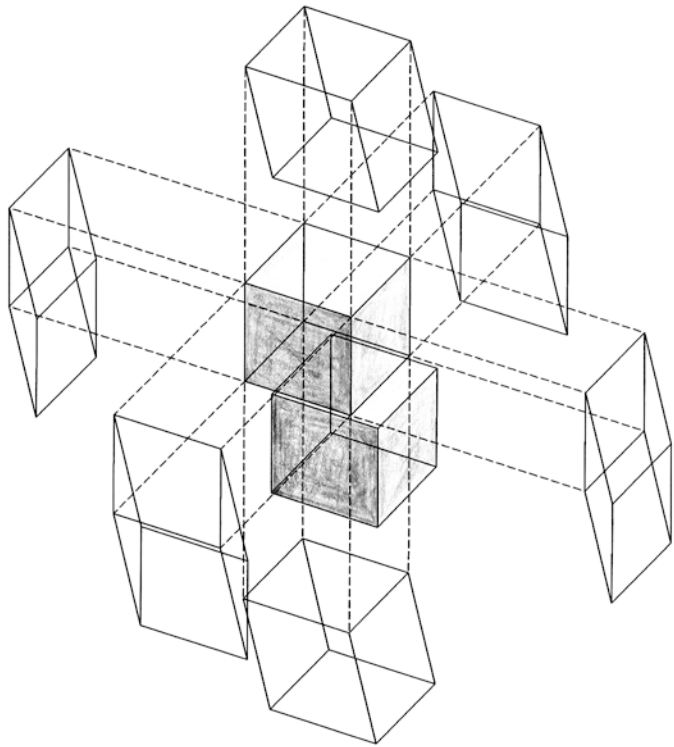

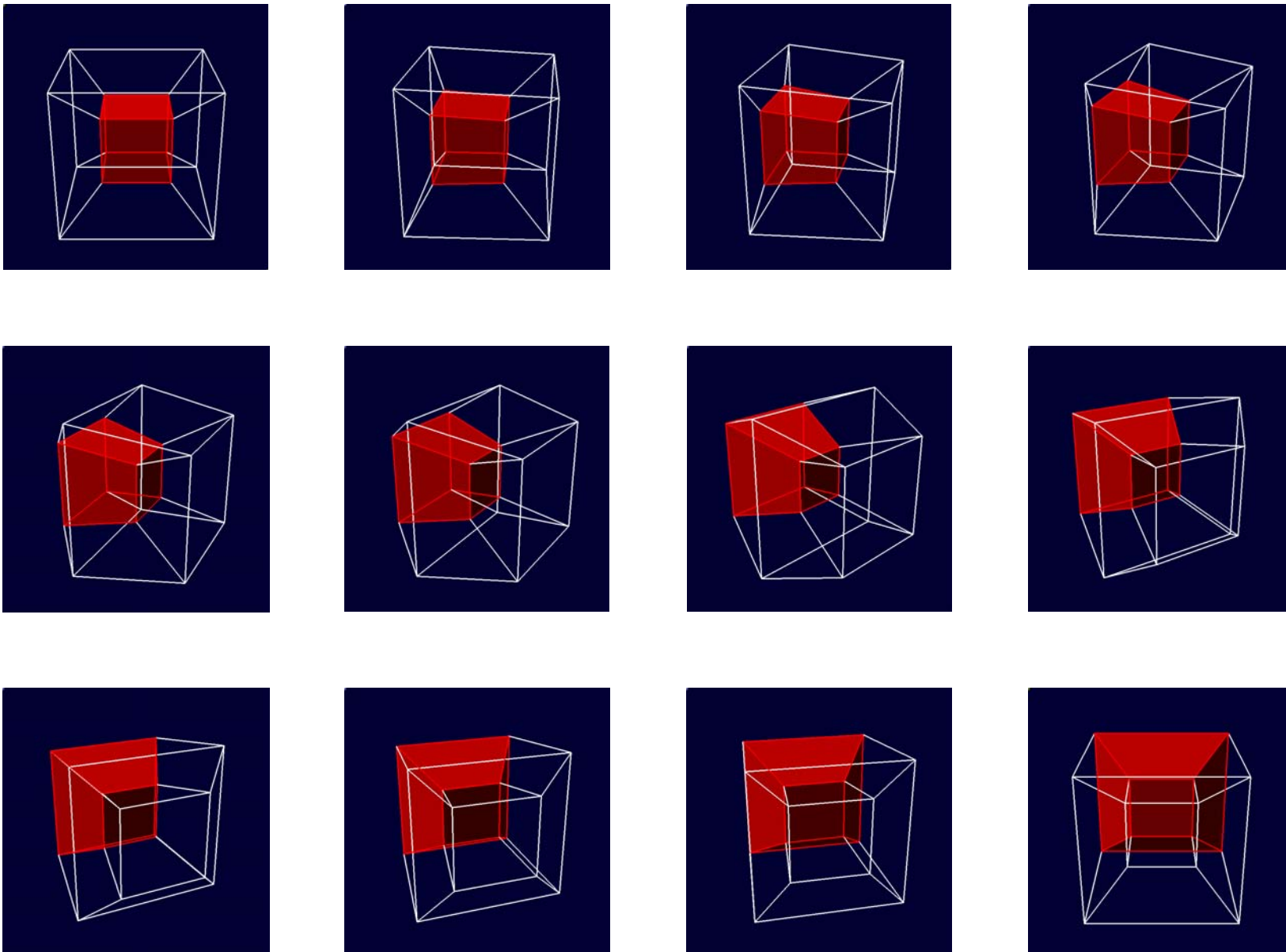

Sequential images of the simultaneous 3-dimensional rotation and 4-dimensional rotation of a hyper-cube

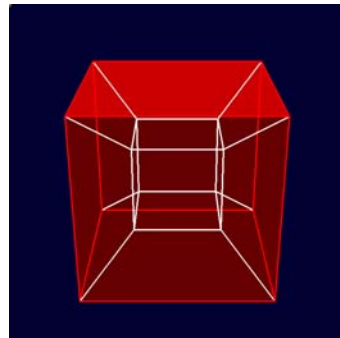
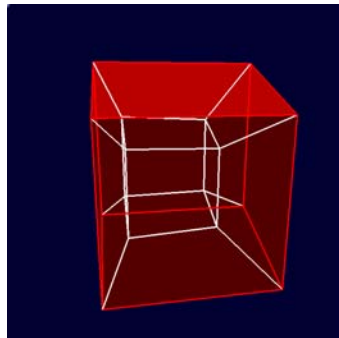
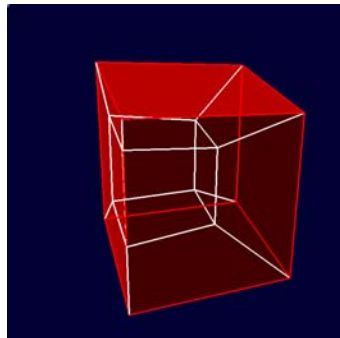
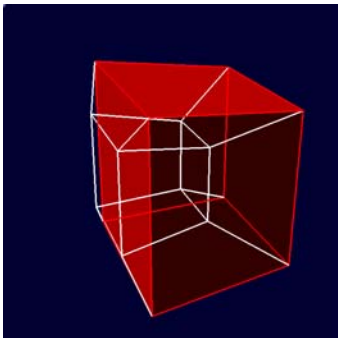
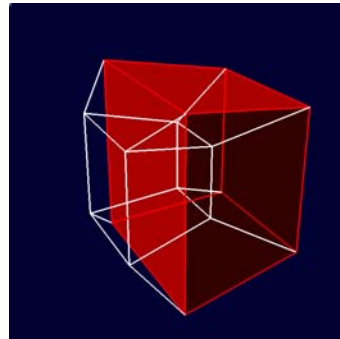
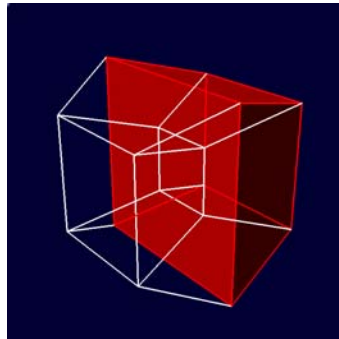
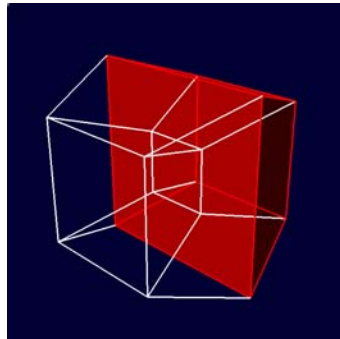
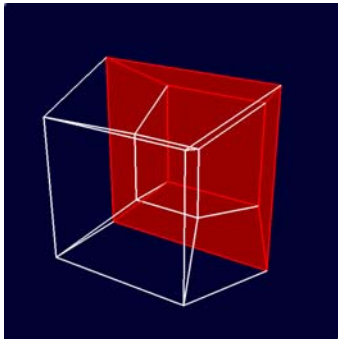
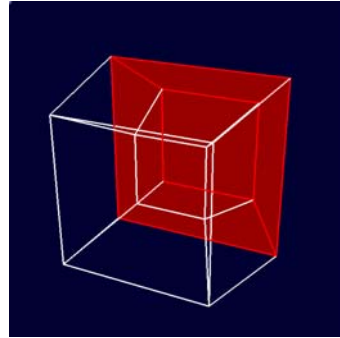
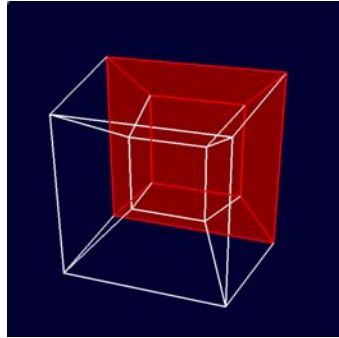
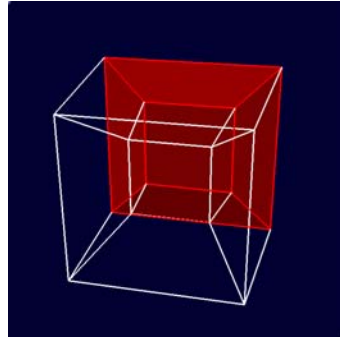
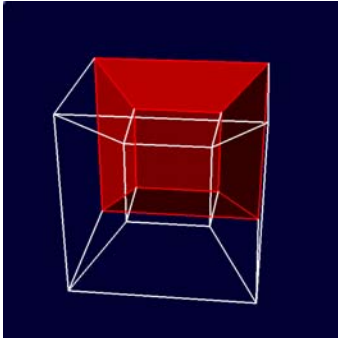

Form, whatever the means of expression, always must be understood in connection with space. And this so-called embracing “concavity”—and why not embraced “convexity” as well—is nothing else than the sphere of light, shadow, and atmospheric effects within which form must be conceived, and within which form exerts its influence.

Eliel Saarinen, Search for Form in Art and Architecture, 1948

...it is certain that mathematics generally, and particularly geometry, owes its existence to the need which was felt of learning something about the behavior of real objects. The very word geometry, which, of course, means earth-measuring, proves this. ...geometry [mathematics] must be stripped of its merely logical-formal character by the coordination of real objects of experience with the empty conceptual schemata of axiomatic geometry.

Albert Einstein, Geometry and Experience: lecture before the Prussian Academy of Sciences, 1921

It is remarkable that the vertices of $\{5,3,3\}$ [hyper-dodecahedron] include the vertices of all the other fifteen regular polytopes in four dimensions. The dodecahedron $\{5,3\}$ does not have the analogous property in three dimensions; for, although we can inscribe a tetrahedron or a cube in it, we cannot inscribe an octahedron or an icosahedron, nor any of the Kepler-Poinsot polyhedra save $\{5/2,3\}$.

H.S.M. Coxeter, Regular Polytopes, 1963

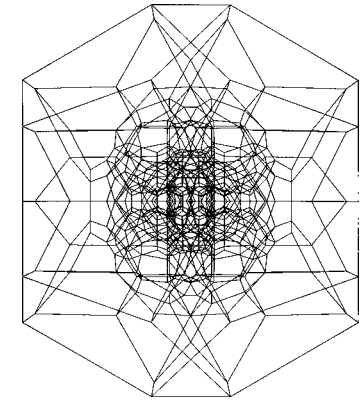
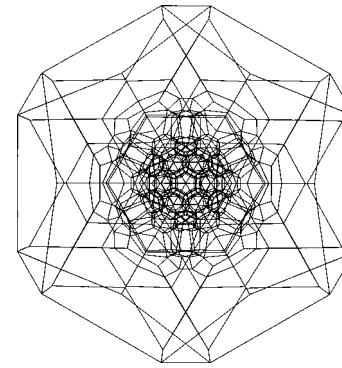
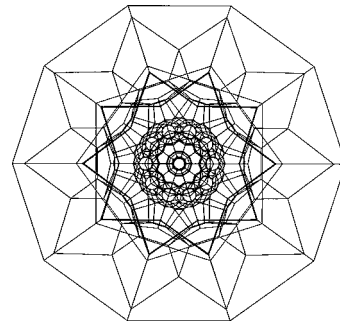
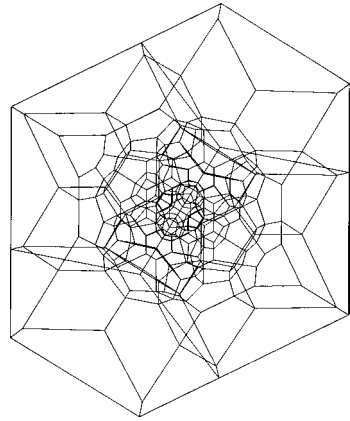

The Hyper-dodecahedron contains 120 dodecahedra mutually connected like the cubes of a hypercube. The following study explores the structure of the connective relations of this beautiful multi-celled polytope. The 20th century geometer H.S.M. Coxeter describes an historically significant property of this polytope, and this has profound implications for the author's Thesis. This unique hypersolid contains, in a purely mathematical sense, all of the other regular polytopes in 4 dimensions. Thus, it would appear that the poetic and intuitive notions of Pythagoras and Plato are vindicated in a most astounding way 2000 years after their time. As higher space has become an important element of our 20th century cosmography, the classical idea of the all-encompassing nature of the dodecahedron has now gained a special validity by the new scientific conception of the universe.

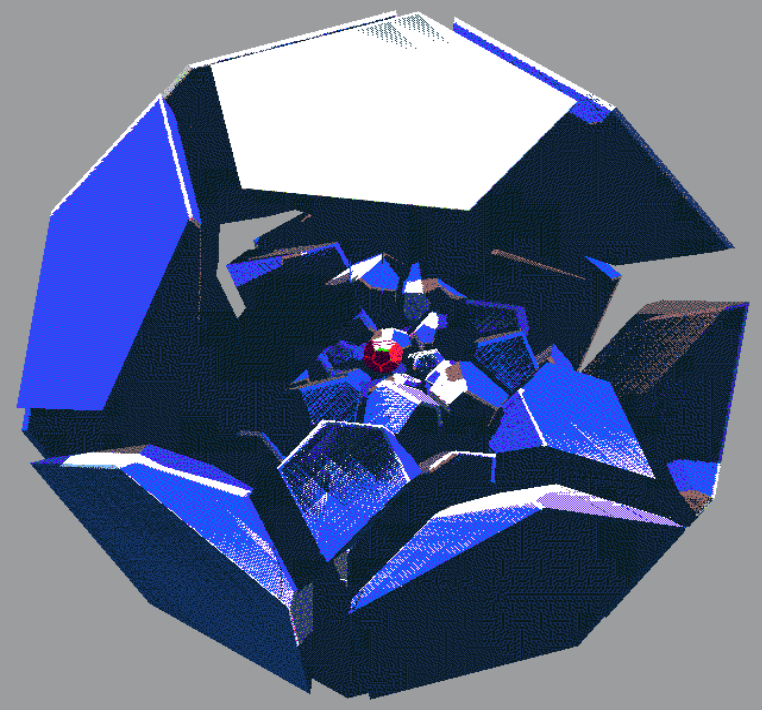

Decomposition Studies of the Hyper-Dodecahedron

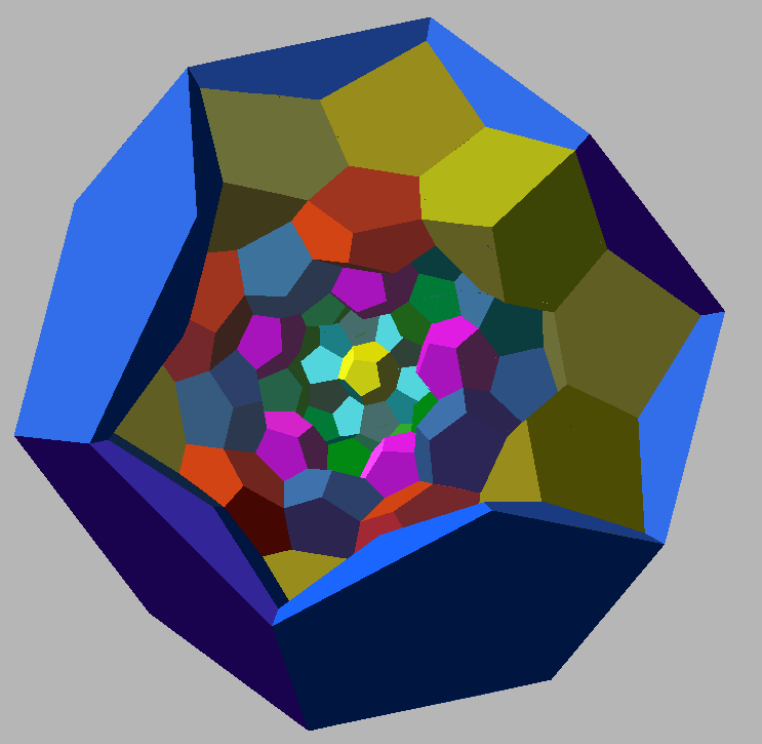

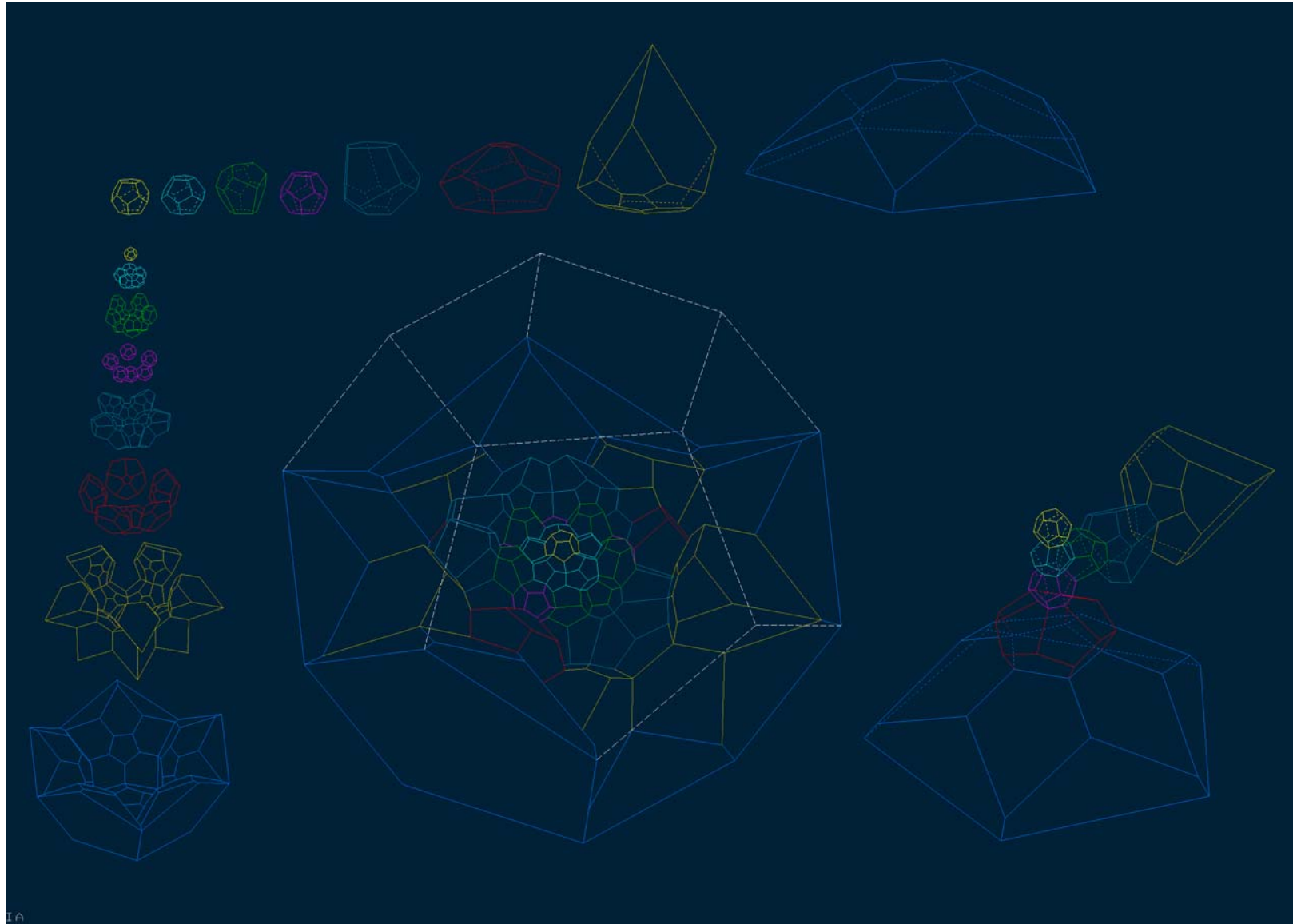

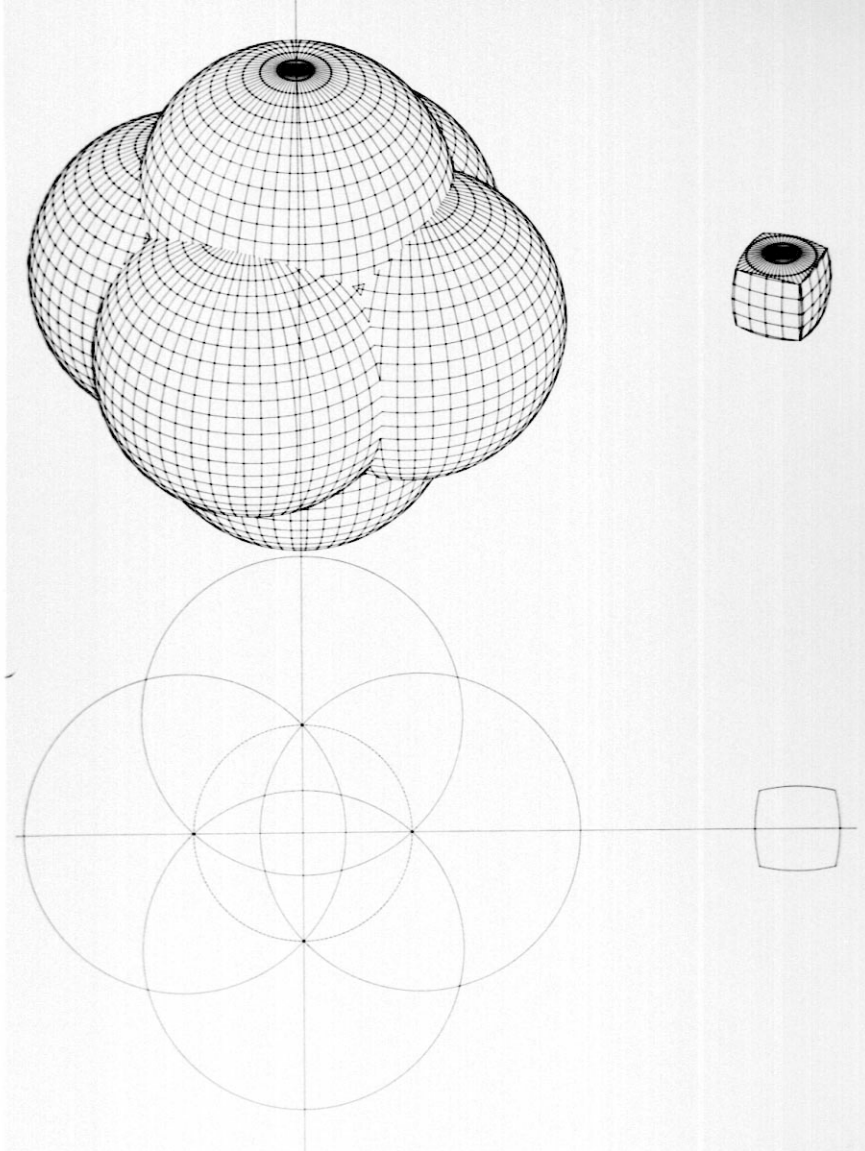

A cube modeled and drawn in spherical space

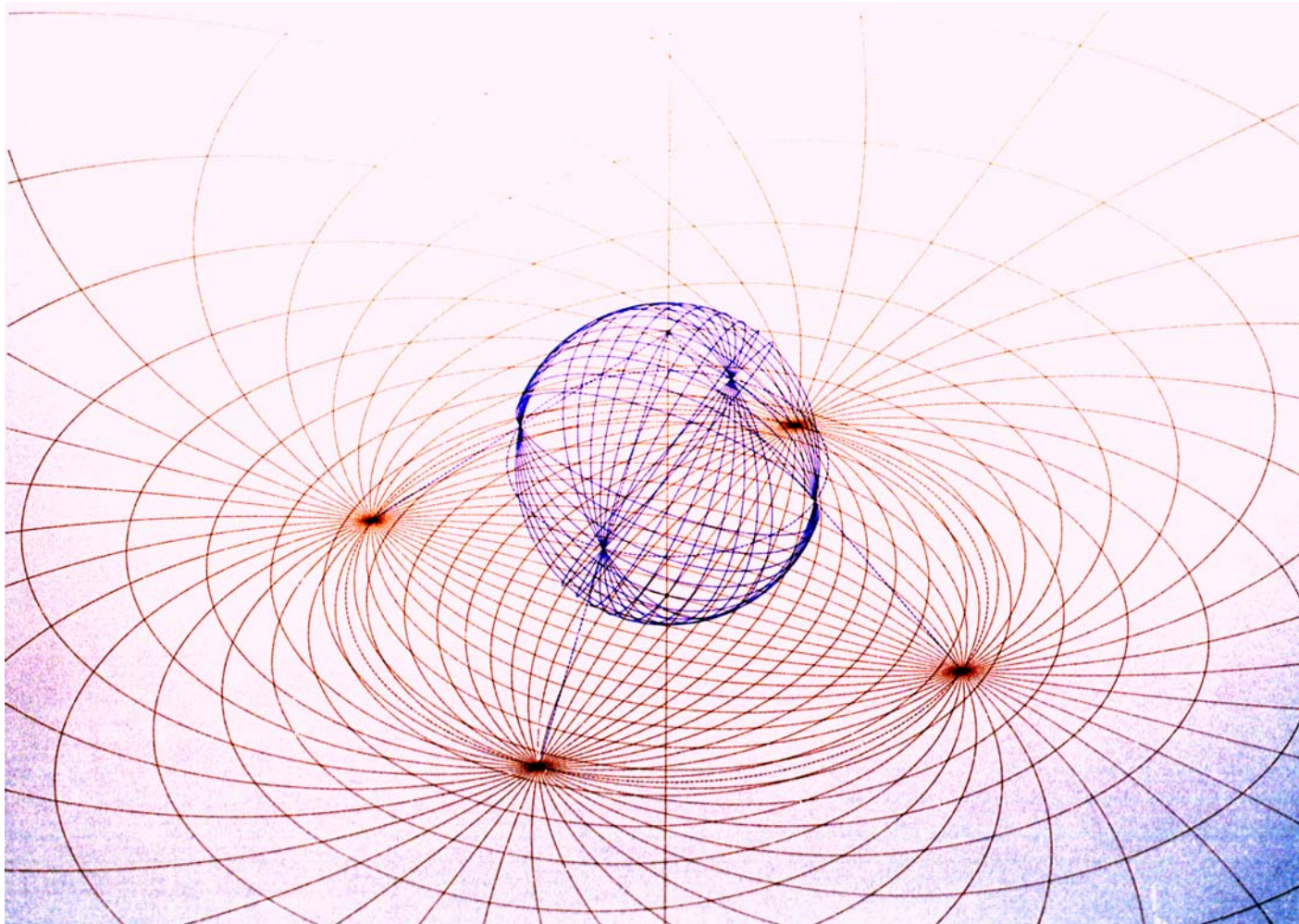

The scientifically derived conception of spherical space relates to a spatial geometry that departs from the Euclidian postulates which have been completely accepted for almost 20 centuries. This may explain why it is so difficult to comprehend the spherical deformation of our space. Higher dimensional space is, of course, implicit in this idea, because in order for space to deform there must be a "greater" domain into which the deformation can move. The drawing above is a study of the stereographic projection of a grid. This projection system allows a way of mapping back onto a Euclidian plane a spherical space or simply the distortions of that spherical space. Thus, it is then possible to understand deformed space from our Euclidean perspective.

THE LYCEUM PROJECT

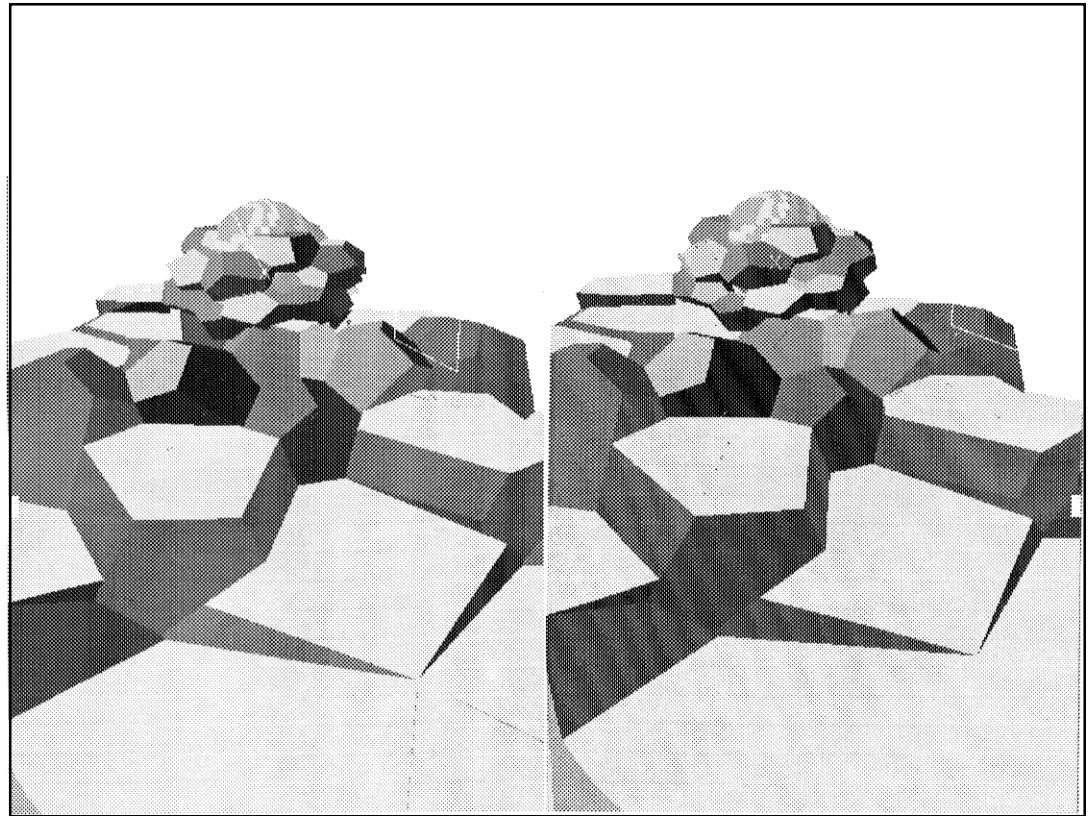
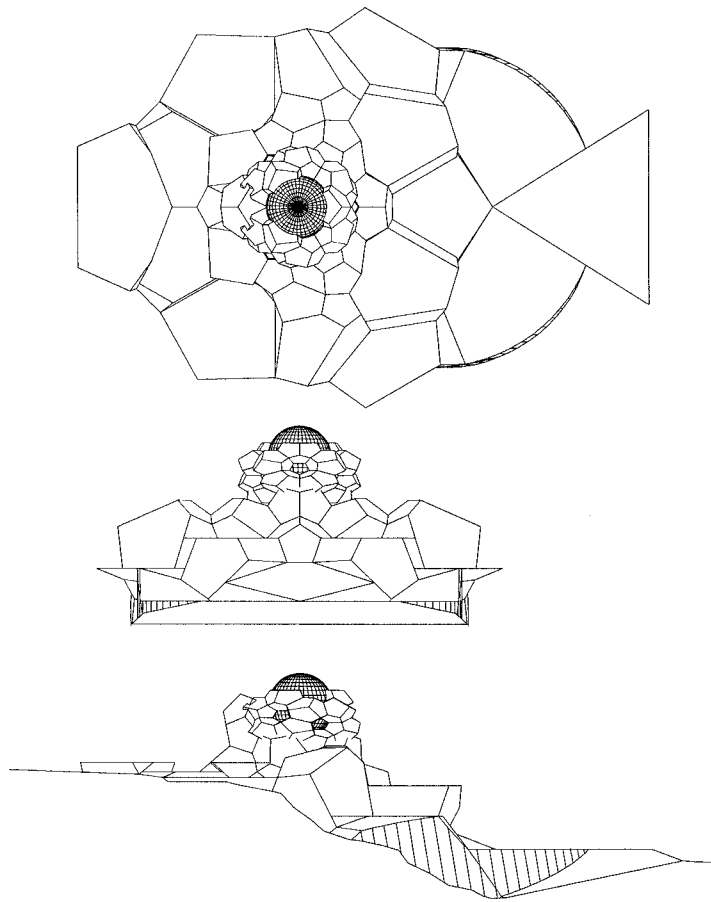

Stereogram of an early massing model

The beginnings of a conceptual geometry explored in architectural terms

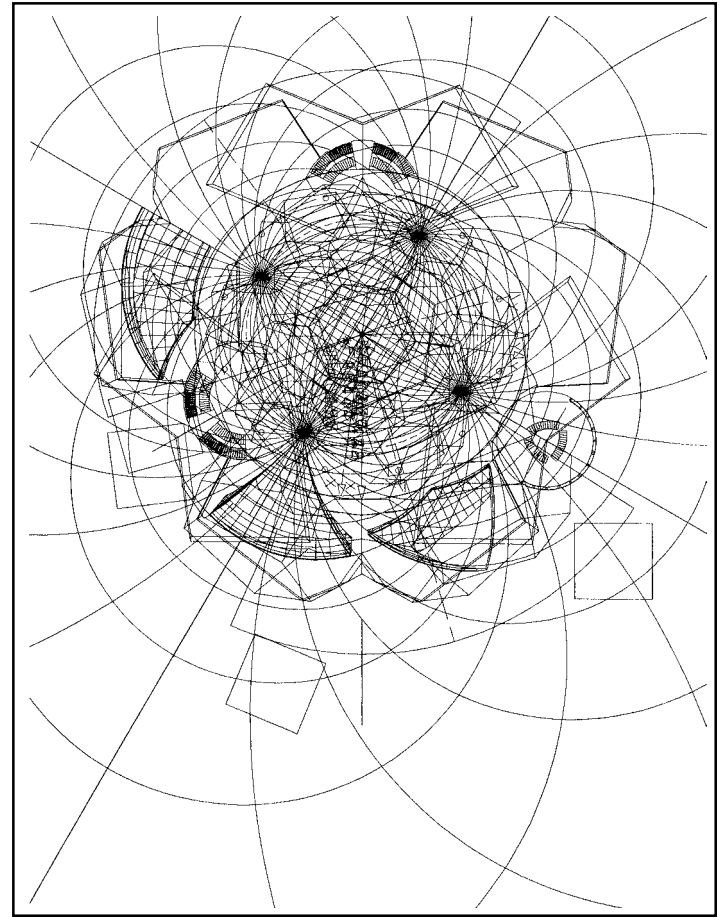
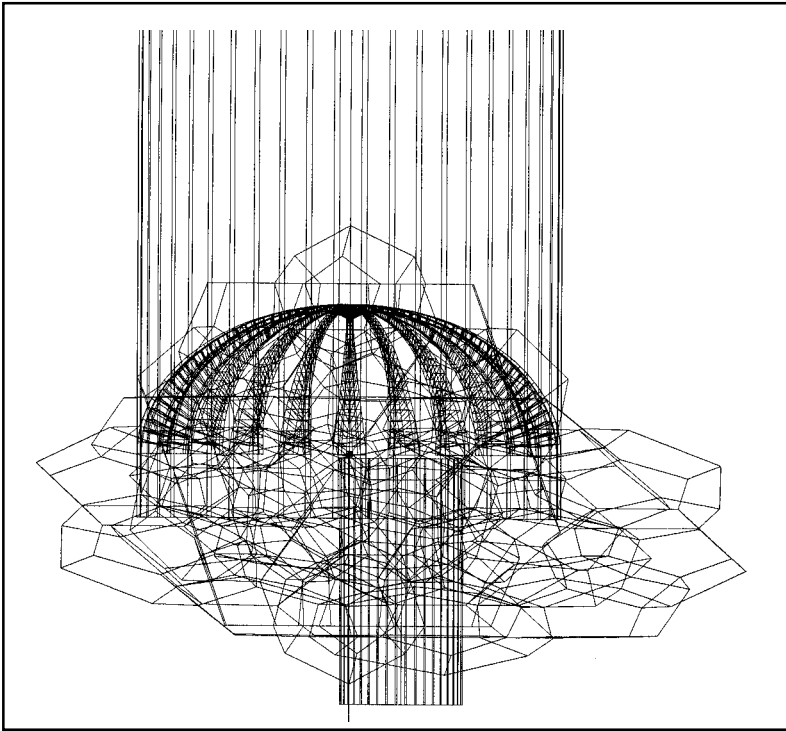

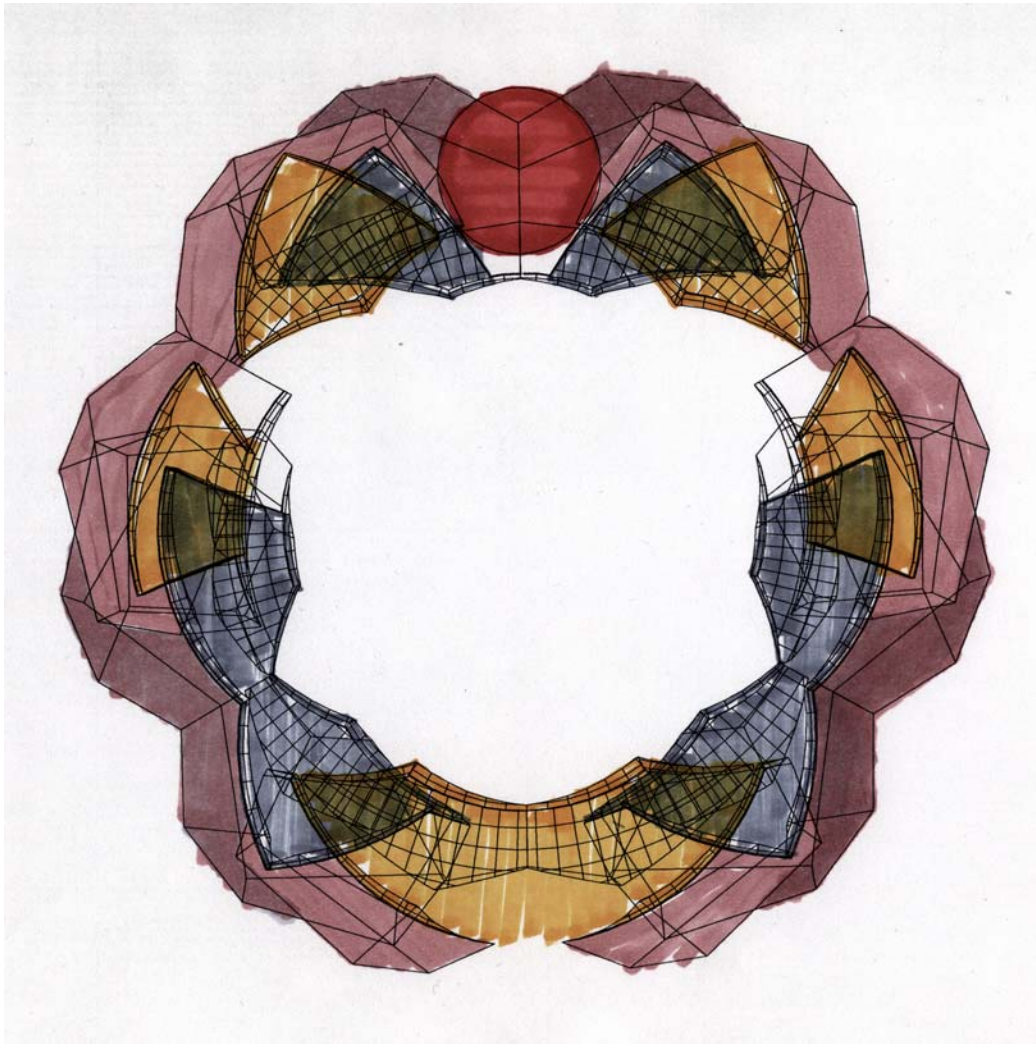

The basic part of the project is developed. Two different geometric schemes are brought together to embody a cosmographic model. The highly symbolic geometry of the hyper-dodecahedron which is connected with the 'classical' universe embraces or surrounds the interior confines of the spherical geometry which, in simple terms, constitutes an orthogonal grid that is distorted by the gravitational effects of spherical space. Such a grid geometry then becomes non-Euclidian and is used as a formal principle to order the composition and shape of the interior spaces of the project. Conceptual space echoes cosmic space.

Spherical room computer constructions of the lyceum

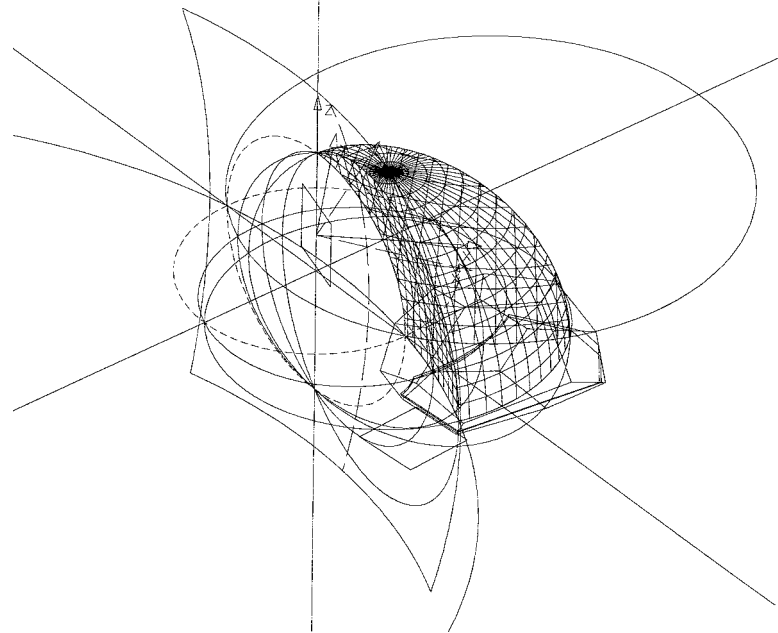
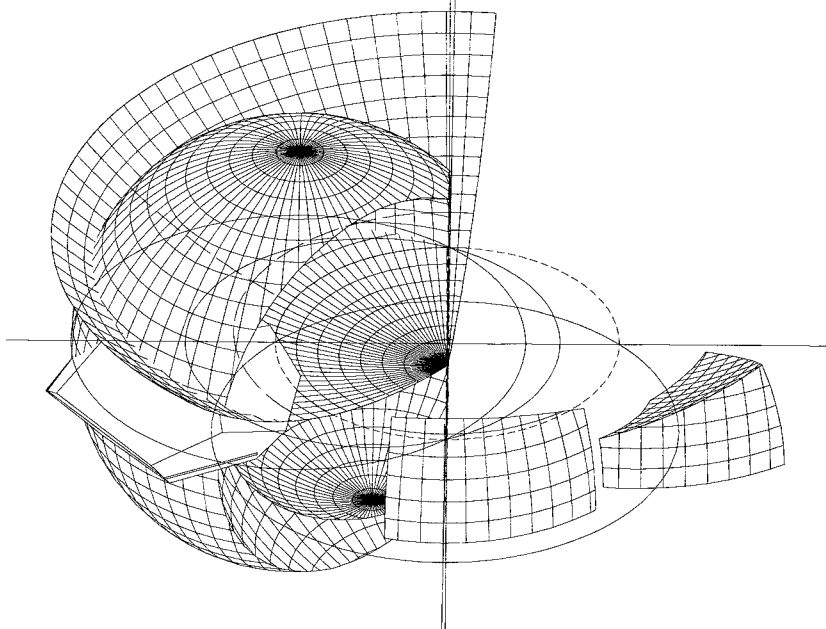
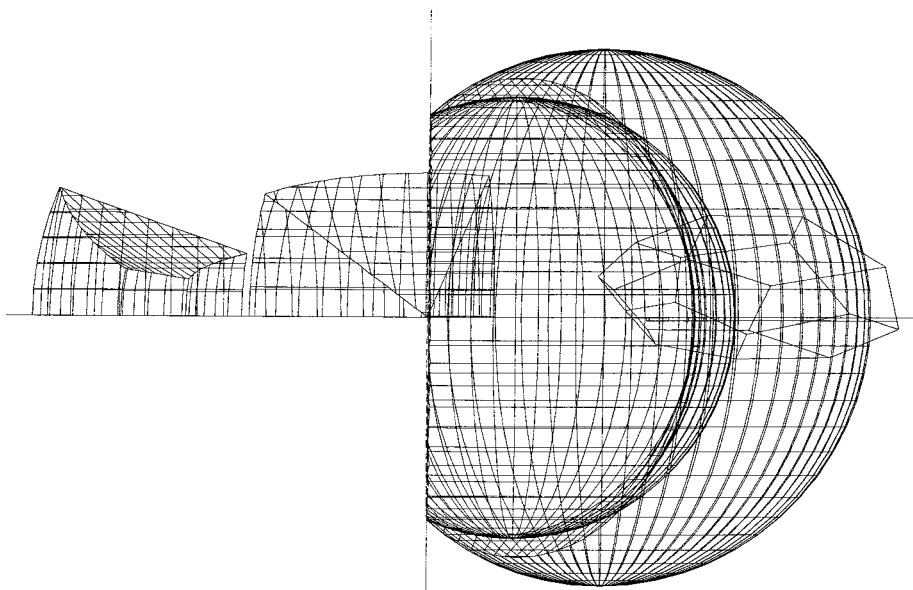
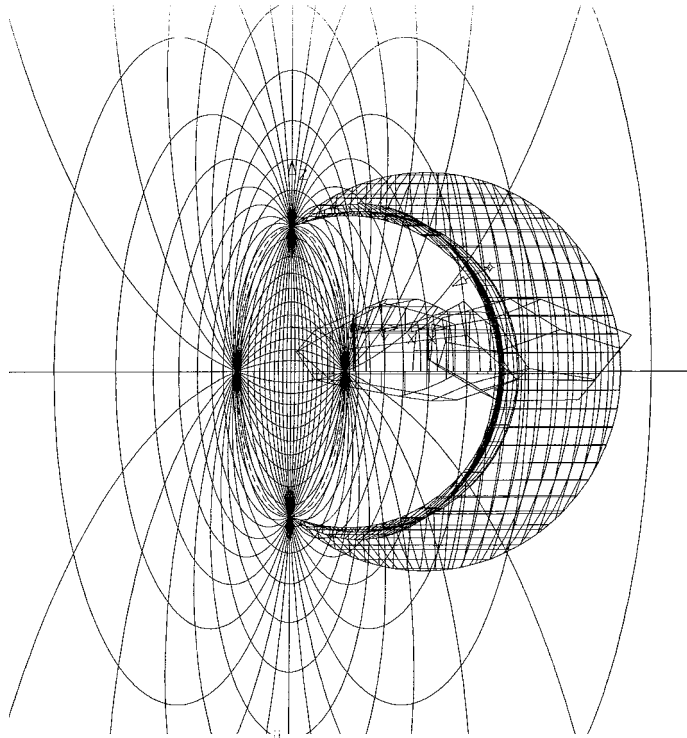

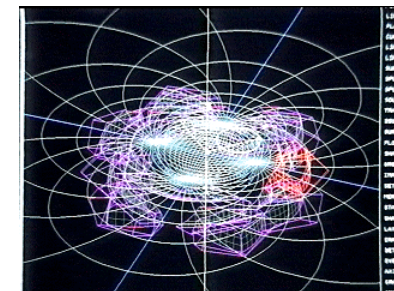
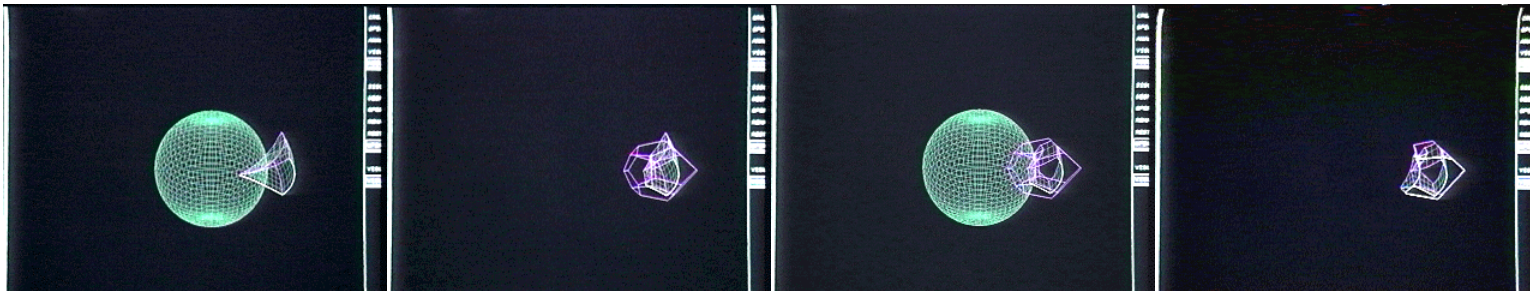
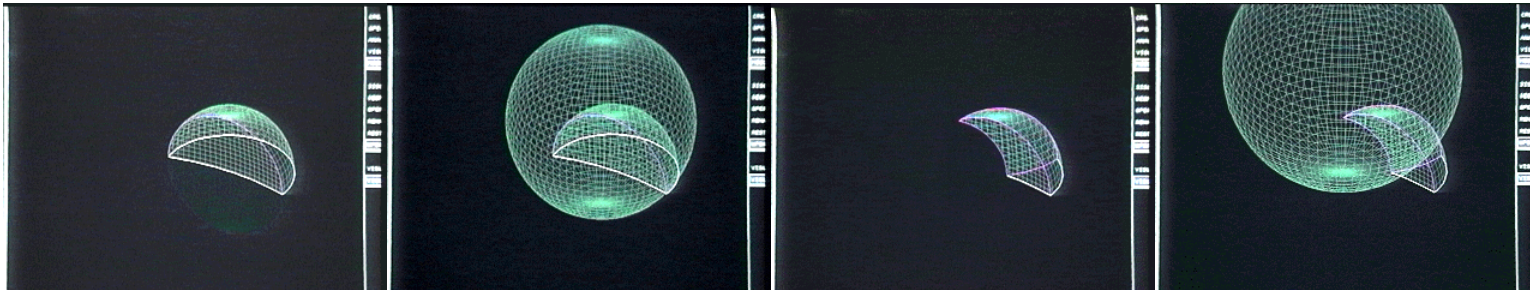
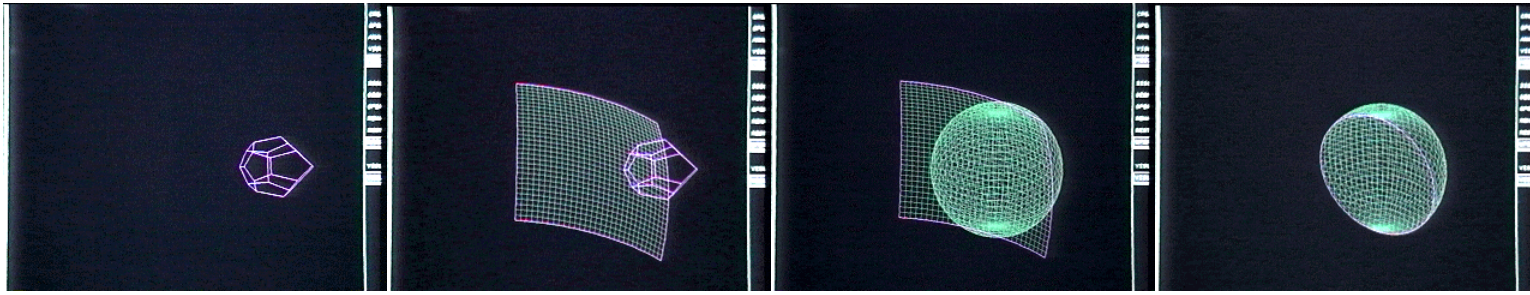

Sequential development of a spherical room

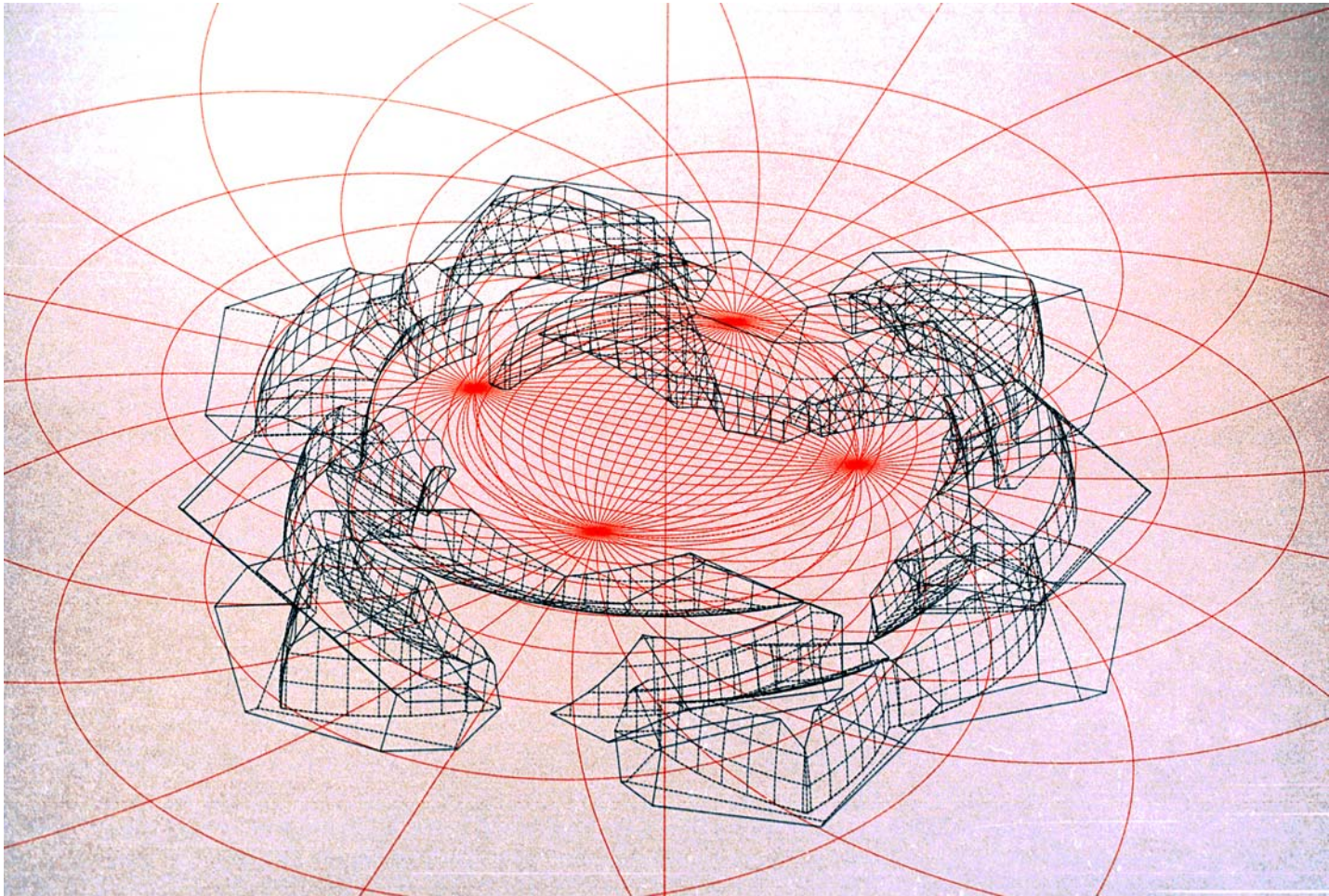

Layout of the relationships of all spherical rooms

LYCEUM PROJECT PLATES

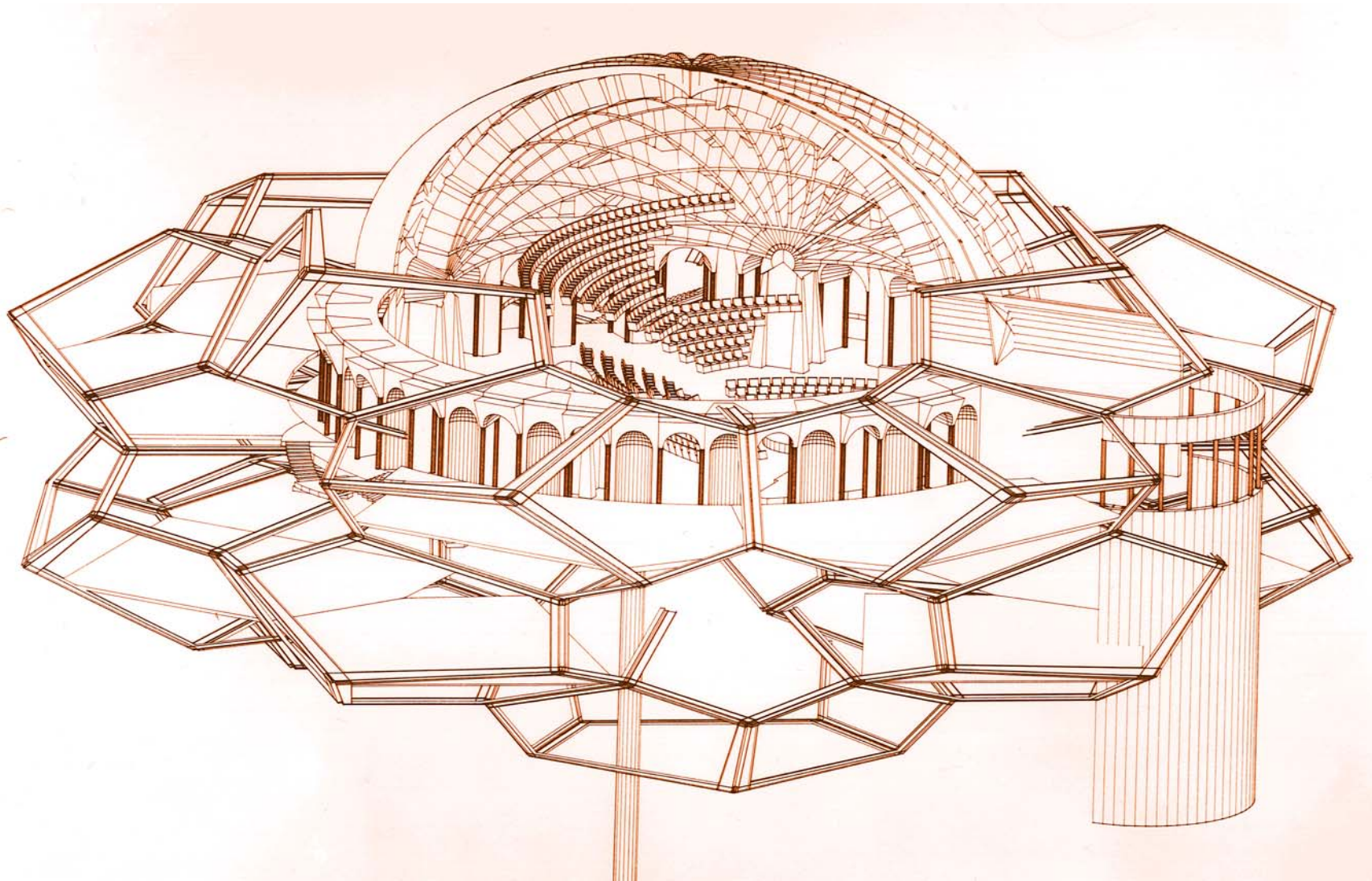

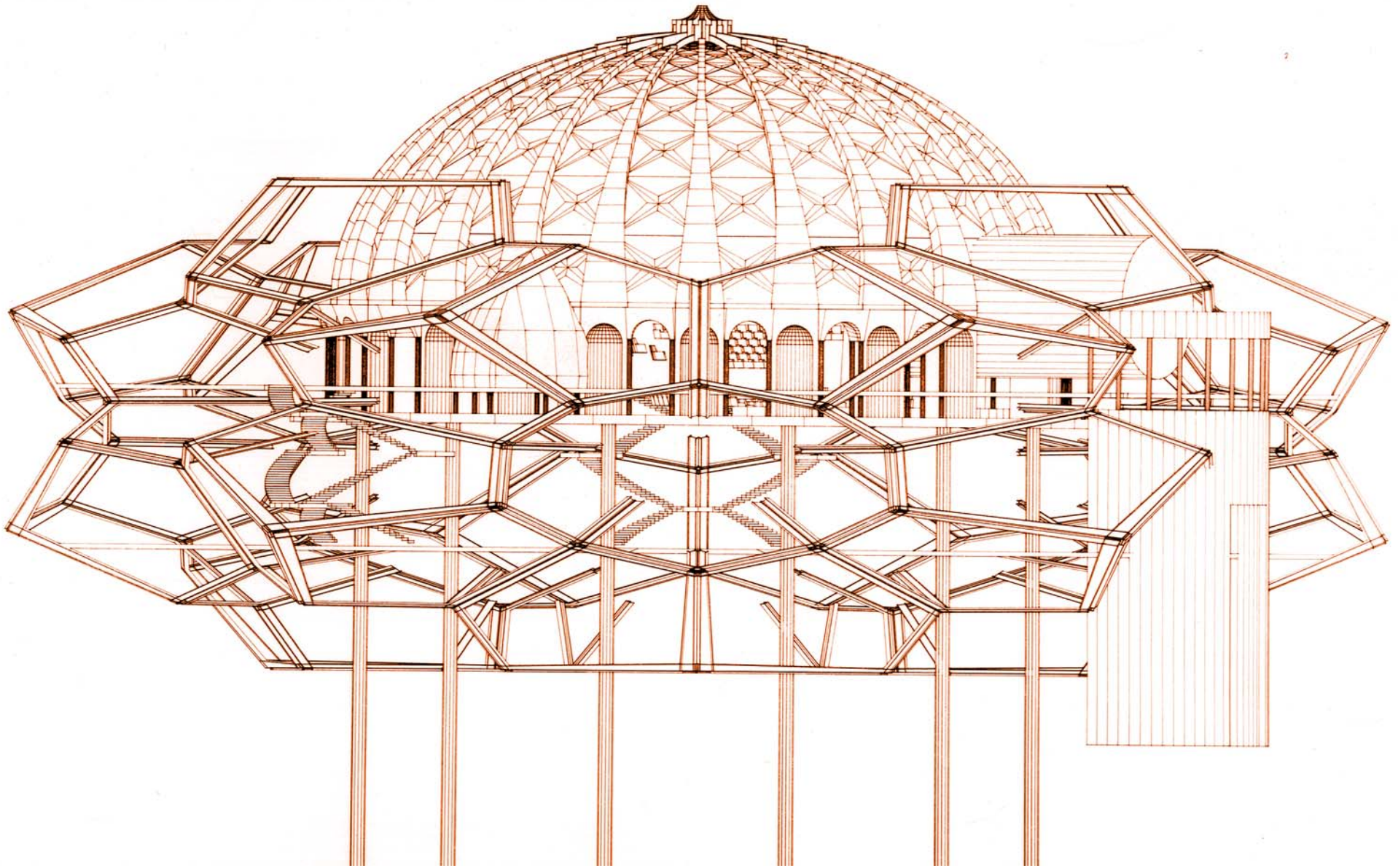

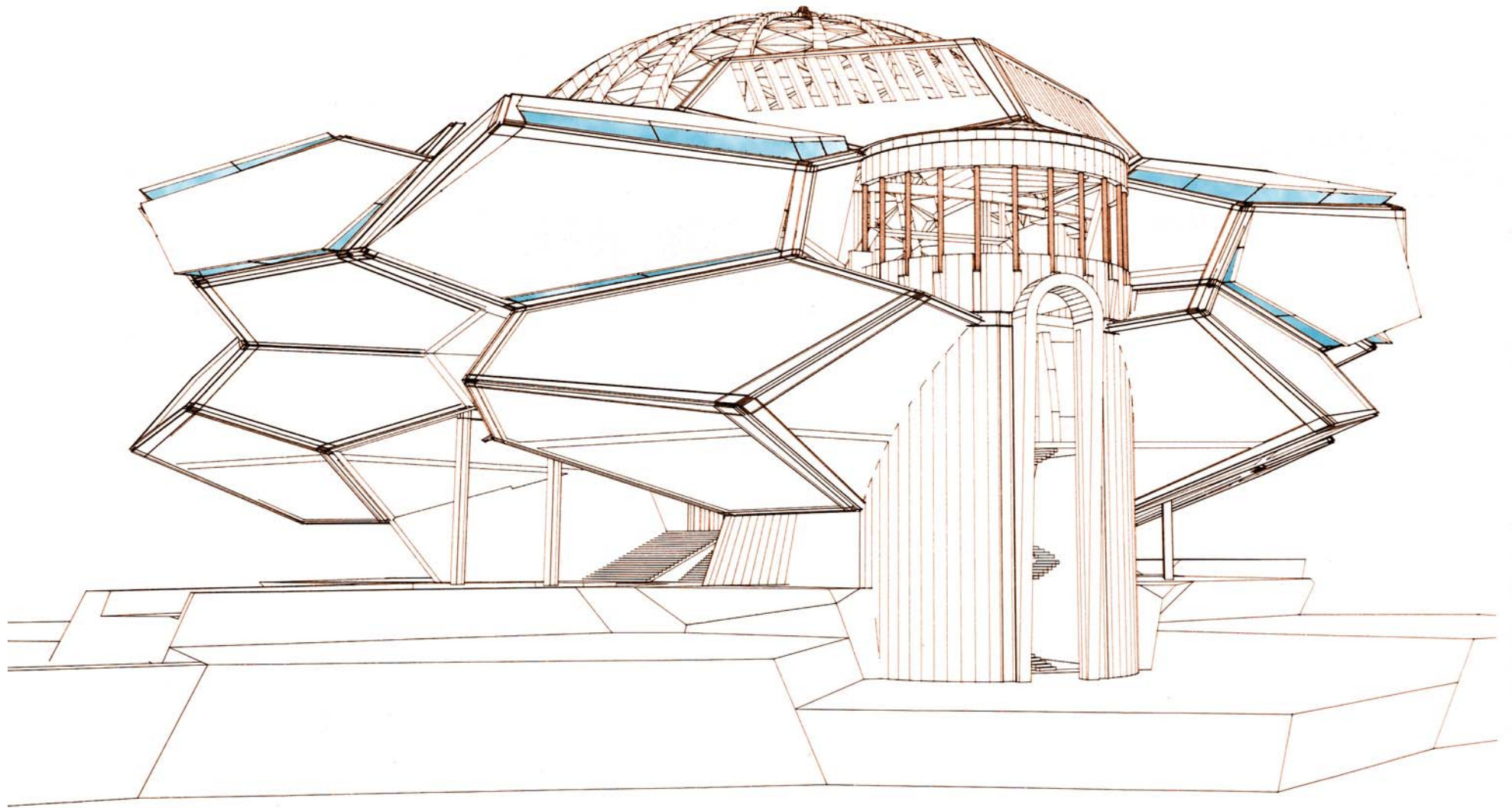

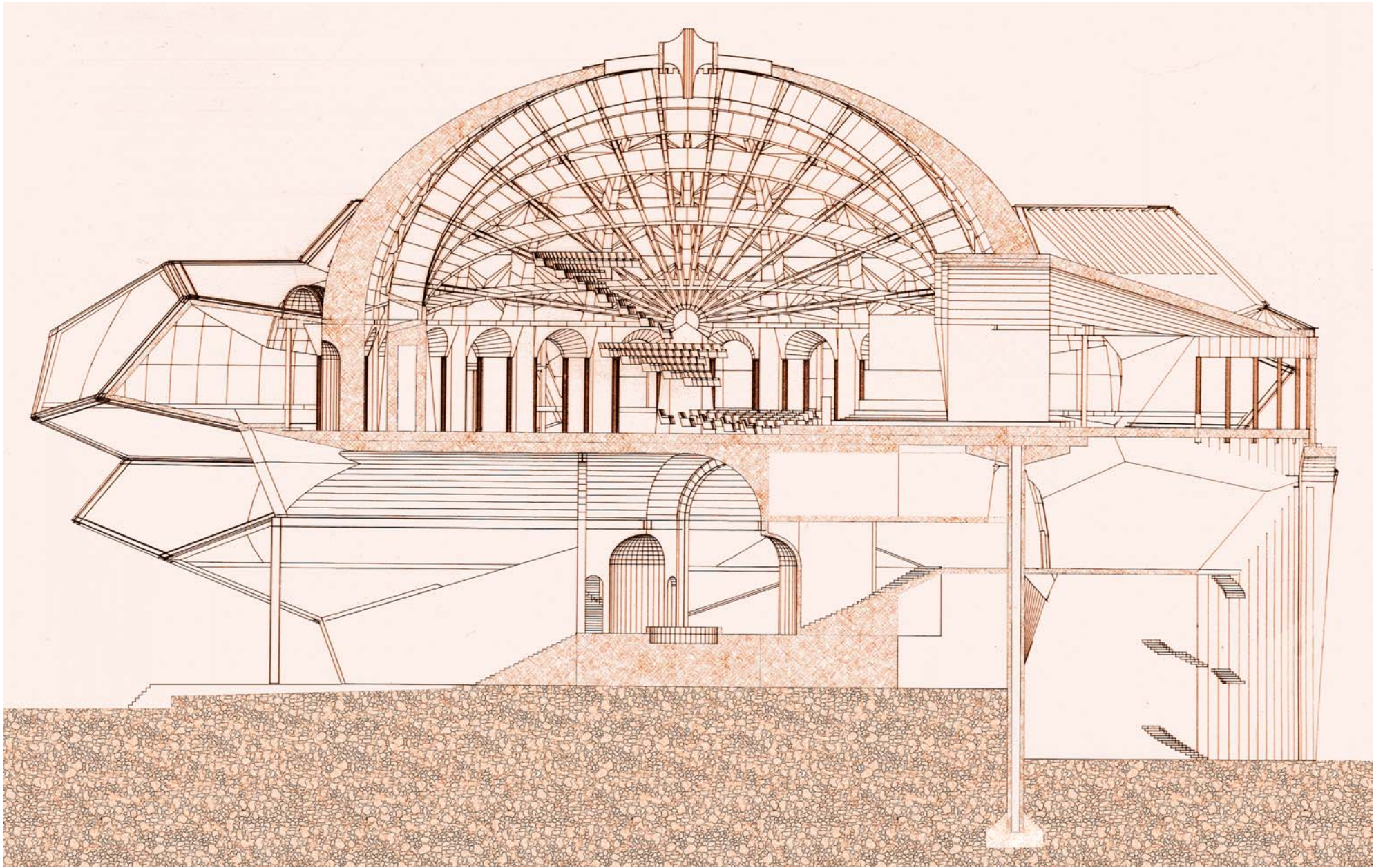

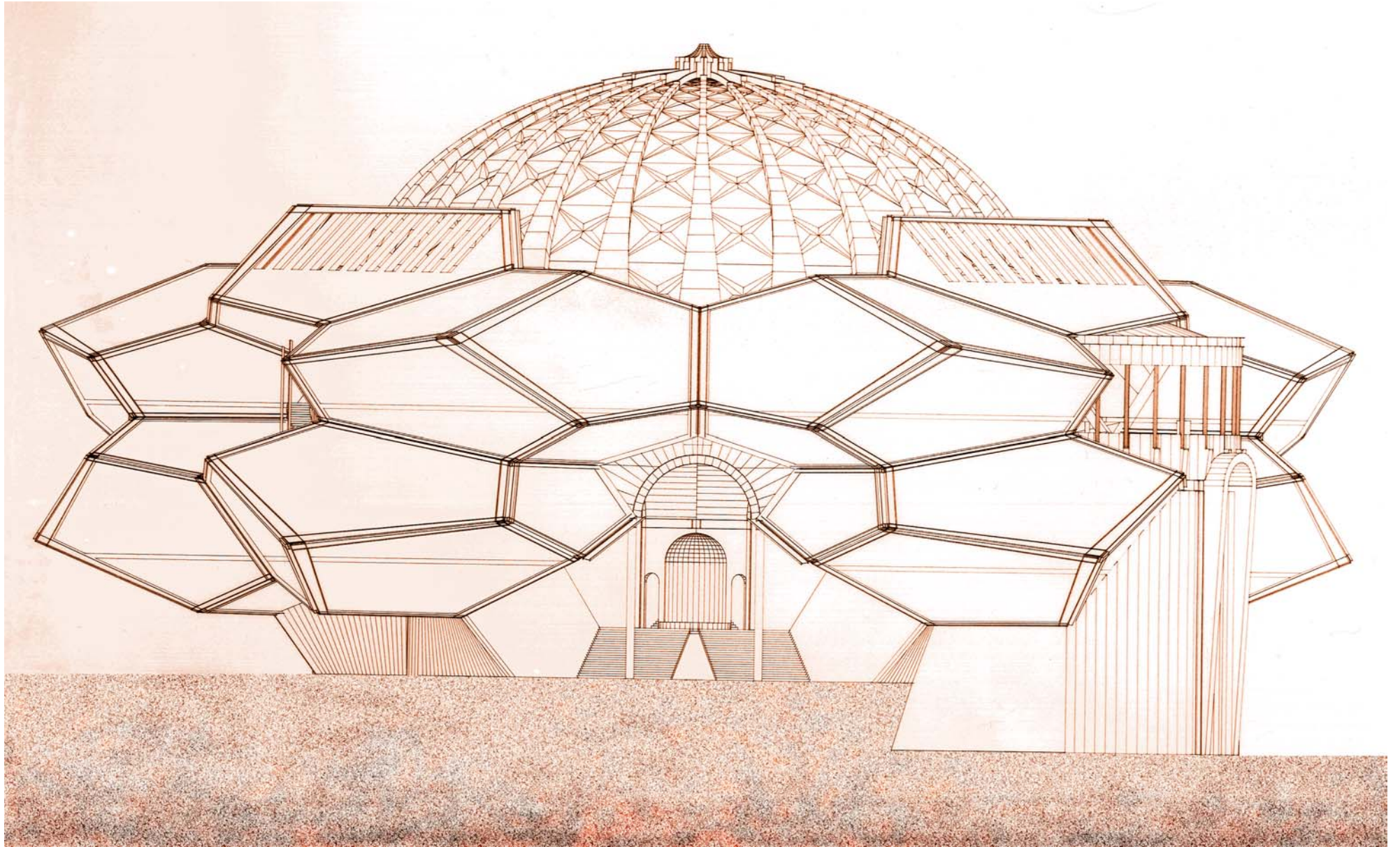

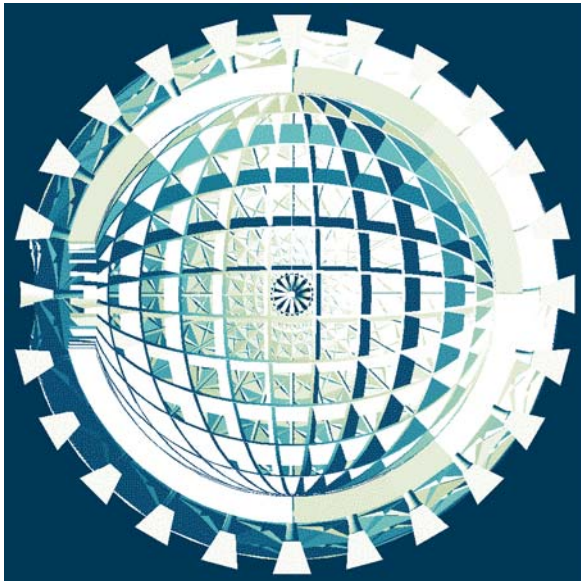
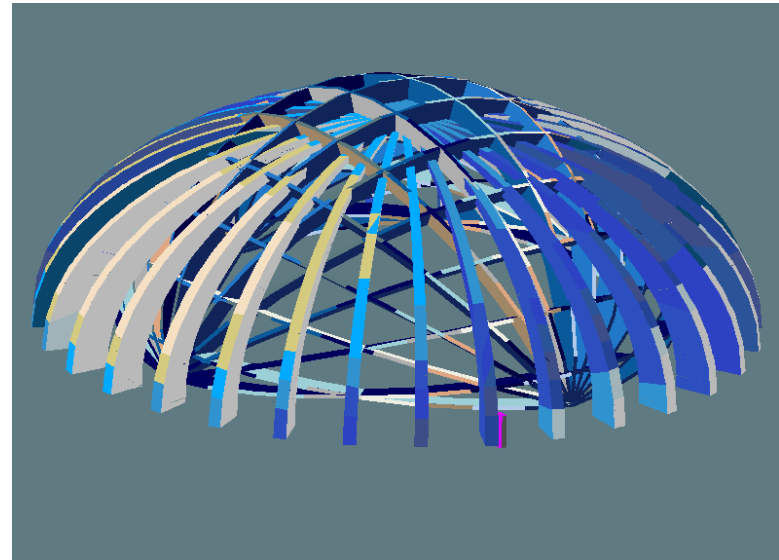
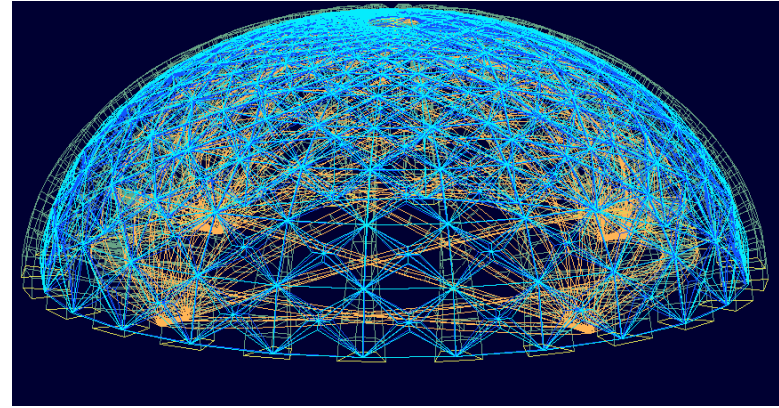
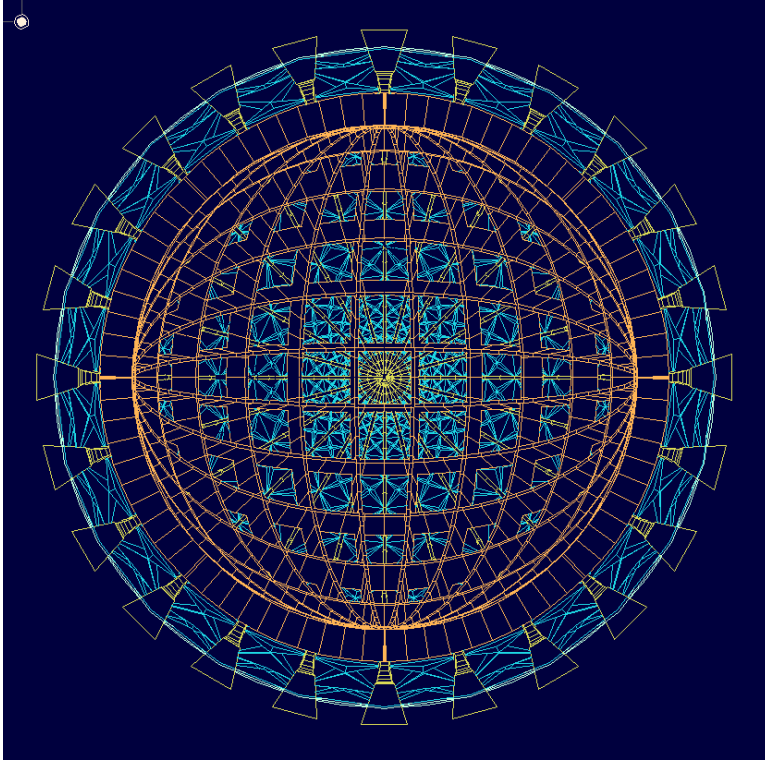

Progressive Study of the Rotunda CAD Model

Bibliography

- Brisson, David W. (Editor) *Hypergraphics: Visualizing Complex Relationships in Art, Science and Technology*. published for the American Association for the Advancement of Science by Westview Press, Boulder, Colorado. 1978.
- Colquhoun, Alan. *Modernity and the Classical Tradition: Architectural Essays 1980-1987*. MIT Press, Cambridge, Massachusetts. 1989.
- Coxeter, H.S.M. *Regular Polytopes*. Princeton University Press, Princeton. 1963.
- Damisch, Hubert. *The Origin of Perspective*. trans. by John Goodman. MIT Press, Cambridge, Massachusetts. 1994.
- Einstein, Albert. *Relativity: The Special and the General Theory*. Authorized trans. by Robert W. Lawson. Crown Publishers Inc. London. 1952.
- . *Geometry and Experience*: lecture before the Prussian Academy of Sciences. Reprinted by Springer, Berlin. 1921.
- Feynman, Richard P. *The Feynman Lectures on Physics*. California Institute of Technology, Addison-Wesley Publishing, Palo Alto, California. 1963.
- . *QED: The Strange Theory of Light and Matter*. Princeton University Press, Princeton, New Jersey. 1985.
- Ghyka, Matila. *The Geometry of Art and Life*. Sheed and Ward, New York. 1946.
- Henderson, Linda Dalrymple. *The Fourth Dimension and Non-Euclidean Geometry in Modern Art*. Princeton University Press, Princeton, New Jersey. 1983.
- James, Jamie. *The Music of the Spheres: Music, Science, and the Natural Order of the Universe*. Grove Press. New York. 1993.
- Jencks, Charles. *The Architecture of the Jumping Universe*. Academy Editions, London, England. 1995.
- Kaku, Michio. *Hyperspace: A Scientific Odyssey Through Parallel Universes, Time Warps, and the 10th Dimension*. Oxford University Press, New York. 1994.
- Kaufmann, William J. III. *Relativity and Cosmology*. Harper & Row Publishers, London. 1973.
- Kuhn, Thomas S. *The Structure of Scientific Revolutions*. University of Chicago Press, Chicago. 1962.
- Loeb, Arthur. *Space Structures-Their Harmony and Counterpoint*. Harvard University Press, Cambridge. 1976.
- Minkowski. *Space and Time*: paper interpreting special relativity as a theory about the geometry of space-time. 1908.
- Norberg-Schulz, Christian. *Genius Loci, Towards a Phenomenology of Architecture*. Rizzoli Publications, New York, 1979.
- Osserman, Robert. *Poetry of the Universe, A Mathematical Exploration of the Cosmos*. Anchor Books, Doubleday, New York. 1995.
- Penrose, Roger. *The Emperor's New Mind; Concerning Computers, Minds, and the Laws of Physics*. Oxford University Press, Oxford, England. 1989.
- Plato. *Timaeus*: from The Dialogues of Plato. Translated by Benjamin Jowett. Vol. 7 of *Great Books of the Western World*, Encyclopedia Britannica, Chicago. 1952.
- Reichenbach, Hans. Trans by Maria Reichenbach. *The Philosophy of Space & Time*. Dover Publications, New York. 1958.
- Rowe, Colin. *The Mathematics of the Ideal Villa and Other Essays*. MIT Press, Cambridge, Massachusetts. 1976.
- Rucker, Rudolf v. B. *Geometry, Relativity, and the Fourth Dimension*. Dover Publications, New York. 1977.
- Saarinen, Eliel. *The Search for Form in Art and Architecture*. Dover Publications, Inc., New York. 1985. original date of publication: 1948.
- Tzonis, Alexander; Lefaivre, Liane. *Classical Architecture, The Poetics of Order*. MIT Press, Cambridge, Massachusetts. 1986.
- Vitruvius; translated by Morris Hicky Morgan, PH.D. *The Ten Books on Architecture*. Harvard University Press, Cambridge, Massachusetts. 1914.

