

The Design of Linearized Power Amplifier for Wireless Communications

Khaled A. Fayed

Thesis submitted to the faculty of the
Virginia Polytechnic Institute and State University
in partial fulfillment of the requirements for the degree of

Master of Science
in
Electrical Engineering

Amir I. Zaghloul, Chair

William A. Davis

Sedki M. Riad

Amin K. Ezzeddine

11/16/2009

Falls Church, VA

Keywords:

Power Amplifier, Linearization, Predistortion, Intermodulation

The Design of Linearized Power Amplifier for Wireless Communications

Khaled A. Fayed

ABSTRACT

The interest in higher data rate systems is rising very quickly in the area of wireless communications. High data rates mean high Peak to Average Ratio, *PAR*. This imposes big challenge on the linearity requirement of Power Amplifiers, *PAs*. The simplest technique that has been used is backing off the PA. However, this leads to very inefficient performance. A lot of more complex techniques were suggested in the literatures to trick the tradeoff between linearity and efficiency. So we discuss the advantages and disadvantages of those techniques. In addition we suggest a new technique called *Power Amplifier Linearization using a Mirror Predistorter*. This technique is based on the use of a mirror PA that generates a copy of the main PA nonlinearity, and then feeds it in the proper phase and magnitude into the input in order to cancel the intermodulation terms at the output. Simulation and on the bench lab results validate the suggested technique. Also a hybrid PA module was designed and tested based on the suggested technique, and showed an improvement of 23 dB in the Third Order Intermodulation to Carrier ratio, *IMD3* of the PA at 7.5 dB back off.

Acknowledgments

I thank Allah, GOD, for providing me with all the tools and resources that I need to get this degree.

I would like to thank my Advisor, Dr. Amir Zaghloul, and my committee members, Dr. William Davis and Dr. Sedki Riad, for supporting me in my research and in writing this thesis with valuable suggestions and comments.

A special thanks for Dr. Ho Huang and Dr. Amin Ezzedine, president and vice president of AMCOM Communications, for their support throughout my research hosted by their company, for their valuable technical discussions, and for facilitating all the necessary resources for me to get this work done.

I would like to express my gratitude to my parents who supported me in every step of my life with their love and encouragement. My very special thanks goes to my wife Heba for her love, support, and patience.

My final thanks goes to my newborn daughter Jana for being a great source of joy in my life.

Khaled Fayed
November 16th, 2009

Table of Contents

1	Introduction.....	1
1.1	Power Amplifier Performance Metrics.....	2
1.1.1	Power.....	2
1.1.2	Efficiency.....	2
1.1.3	Linearity.....	3
1.2	Intermodulation Distortion.....	5
1.3	Linearization Techniques.....	8
1.3.1	Feedback.....	9
1.3.2	Feedforward.....	11
1.3.3	Predistortion.....	12
1.4	Thesis Outline.....	17
2	Mirror Predistortion Linearization.....	18
2.1	Method Description.....	19
2.2	Simulation Results.....	23
2.3	Lab Implementation.....	28
2.4	Summary.....	31
3	Hybrid Module.....	32
3.1	Specifications.....	33
3.2	Implementation.....	33
3.2.1	Components Selection.....	33
3.3	Layout.....	41
3.4	Tuning.....	44
3.5	Summary.....	46
4	Measurement Results.....	47
4.1	Lab Setup.....	47
4.2	Results.....	49
5	Conclusion & Future Work.....	56
5.1	Conclusion.....	57
5.2	Future Work.....	58
	References.....	59

List of Figures

Figure 1: AM-AM & AM-PM curves for a representative PA.....	3
Figure 2: Error Vector Magnitude.....	4
Figure 3: Pout vs. Pin of a representative PA.....	5
Figure 4: PA output spectrum when excited by two tones at f_1 and f_2	6
Figure 5: Pout of Fundamental and IM3 vs. Pin.....	7
Figure 6: Polar Loop Linearization.....	10
Figure 7: Cartesian Loop Linearization.....	11
Figure 8: Feedforward Linearization.....	12
Figure 9: Predistortion Linearization.....	13
Figure 10: Simple series diode predistorter.....	14
Figure 11: Cubic Predistorter.....	14
Figure 12: Predistorter used in [7] to cancel both IM3 and IM5 simultaneously.....	15
Figure 13: Predistorter suggested in [10].....	16
Figure 14: Digital Predistortion Linearization.....	17
Figure 15: Mirror Predistortion Linearization.....	20
Figure 16: Intermodulation cancellation concept by using a Predistorter.....	21
Figure 17: Realizing a Mirror PA that has the same nonlinear characteristics as the main PA.....	22
Figure 18: ADS Mirror PD linearized PA Schematic.....	24
Figure 19: Intermodulation and Efficiency testing schematic on ADS.....	25
Figure 20: Simulated IMD3 vs. Pout with & without linearization.....	25
Figure 21: Simulated IMD5 vs. Pout with & without linearization.....	26
Figure 22: Simulated Efficiency & Pout vs. IMD3 with & without linearization.....	26
Figure 23: Lab setup for the Mirror PD linearized PA. Photo by author, 2009.....	29
Figure 24: Lab implementation measured IMD3 vs. Pout with & without linearization.....	30
Figure 25: Lab implementation measured IMD5 vs. Pout with & without linearization.....	30
Figure 26: Lab implementation measured Efficiency & Pout vs. IMD3 with & without linearization.....	31
Figure 27: Schematic of the Hybrid module Mirror PD Linearized PA.....	34
Figure 28: Pi Attenuator.....	37
Figure 29: Delay Tuning on PCB.....	38
Figure 30: Reflective Topology of a 3dB 90° Hybrid coupler.....	39
Figure 31: Variable attenuator by using the Reflective Topology of a 3dB 90° hybrid coupler.....	40
Figure 32: Variable phase shifter by using the Reflective Topology of a 3dB 90° hybrid coupler.....	41
Figure 33: Layout of the Mirror PD Linearized PA.....	42
Figure 34: The built Module for the Mirror PD Linearized PA. Photo by author, 2009..	43
Figure 35: Lab Measurement Setup.....	48
Figure 36: Nonlinear measurement lab setup. Photo by author, 2009.....	49
Figure 37: Hybrid Module measured IMD3 with and without linearization.....	50

Figure 38: Hybrid Module measured IMD5 with and without linearization.....	50
Figure 39: Hybrid Module measured Efficiency & Pout vs. IMD3 with and without linearization.....	52
Figure 40: Hybrid Module measured IMD3 at different two tone frequency spacing.	53
Figure 41: Hybrid Module measured IMD3 at different frequencies.	53
Figure 42: Hybrid Module measured IMD3 at different temperatures.....	54
Figure 43: Hybrid Module measured IMD3 vs. Pout when tuned at different Back Off (BO) values.	55
Figure 44: Suggested Modification to the Mirror PD Linearization.....	58

List of Abbreviations

ACPR	Adjacent Channel Power Ratio
BO	Back Off
DAC	Digital to Analog Converter
EA	Error Amplifier
EVM	Error Vector Magnitude
G	Gain
IMD	Intermodulation to carrier power ratio
IMD3	Third order IMD
IMD5	Fifth order IMD
LUT	Look Up Table
MC	Micro Controller
MMIC	Monolithic Microwave Integrated Circuit
P1dB	Output power when gain is compressed by 1 dB
PA	Power Amplifier
PAE	Power Added Efficiency
PAR	Peak to Average Ratio
PCB	Printed Circuit Board
PD	Predistorter

Chapter 1

Introduction

Power Amplifiers, PAs, are widely used in Communications Systems. Their basic function is to amplify the signal power to a level that is high enough to withstand the transmission loss between transmitter and receiver.

PA is usually implemented using a power device which usually has a nonlinear behavior, i.e., the output power does not increase linearly with the input power especially at high driving power levels. The demand for faster communication systems requires the use of more complex modulation schemes. This results in high PAR signals that could reach more than 15 dB, and consequently imposing tougher requirements on the linearity performance of PAs.

In this chapter, we introduce the major PA design requirements. Then we investigate some of the linearization techniques that were suggested in the literature.

1.1 Power Amplifier Performance Metrics

There are three major tradeoffs that make the design of PA challenging: power, efficiency and linearity.

1.1.1 Power

The power capability of a PA is defined as the 1 dB compression output power, P_{1dB} , at which the gain of the amplifier compresses by 1 dB as compared to the small signal gain. This compression is due to the nonlinearities that are generated as the output signal starts clipping, and is governed by the nonlinear behavior of the power device that is used in the PA and on the input and output matching circuits.

1.1.2 Efficiency

There are two definitions for the efficiency: *Drain Efficiency*, or η , and *Power Added Efficiency*, or *PAE*. The *Drain Efficiency* is defined as the ratio between the output power delivered by the PA to the total consumed DC power:

$$\eta = \frac{P_{out}}{P_{dc}} \cdot 100\% \quad (1.1)$$

Whereas the *Power Added Efficiency* is defined as the ratio between the difference between the output and input powers and the DC power as follows :

$$PAE = \frac{P_{out} - P_{in}}{P_{dc}} = \frac{P_{out} - P_{out}/G}{P_{dc}} = \eta(1 - 1/G) \quad (1.2)$$

The *PAE* is more representative of the performance of PA since it incorporates the gain of the amplifier, G , by introducing the input power in its calculation. So the *PAE* is always smaller than η , while it approaches it as the gain increases. Since the power amplifiers used throughout this thesis have high enough gain that makes the difference

between the two efficiency definitions very small, we will always use the first definition of the *Drain Efficiency* and we will just refer to it by the word *Efficiency*.

As the amplifier is pushed more and more into compression, the output power increases while the DC consumed power stays relatively constant, consequently the Efficiency increases. High efficiency is crucial for any Wireless systems. For instance in the case of a the Downlink of a Cellular System, lower efficiency means higher power dissipation, and consequently higher system cost at the base stations. Whereas for the Up Link, lower efficiency means shorter Mobile Station battery life; because the PA is usually the most power eater in any wireless system.

1.1.3 Linearity

An ideal PA would have constant gain and phase shift from input to output at different input power levels. However, real PAs are usually nonlinear in the sense that their gain and phase shifts change with input power. This is usually described by two curves for every PA: AM-AM (Amplitude to Amplitude) and AM-PM (Amplitude to Phase) Distortion curves. Representative Power Amplifier AM-AM and AM-PM curves are shown in Figure 1. In these curves we notice that the PA is very linear for low input power levels (usually more than 10 dB below P1dB), however it suffers from strong nonlinear behavior as it approaches the 1 dB compression point.

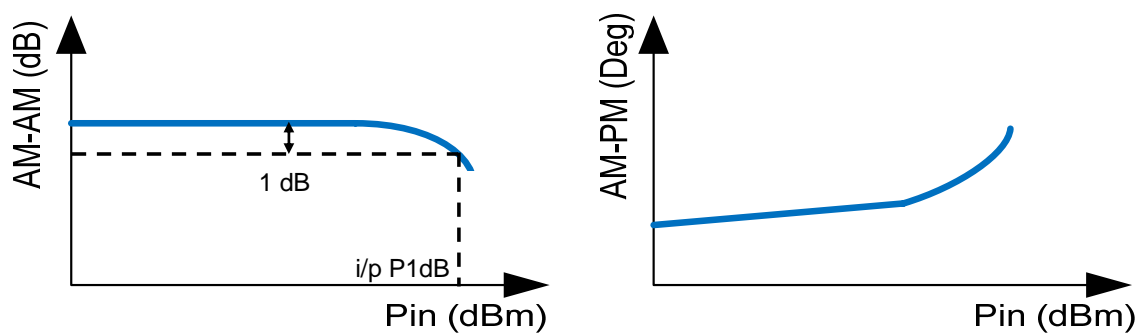

Figure 1: AM-AM & AM-PM curves for a representative PA.

In modern Communication systems information is carried in both amplitude and phase and has, for higher data rate systems, a denser constellation diagrams to the point that any small phase or amplitude error can cause wrong symbol reception at the receiver. When a modulated carrier is passed through a nonlinear PA , in-band frequencies interact and give rise to in-band and out-band intermodulation terms as will be discussed in detail in the next section. The in-band intermodulation terms coincide with the main signal resulting in amplitude and phase errors, while the out-band ones cause unwanted interference into adjacent channels. So the nonlinearity of PA is usually characterized by two specifications:

1. Intermodulation to carrier Power Ratio, *IMD*, or the Error Vector Magnitude, *EVM*, for newer Wireless Communication Systems standards.
2. Adjacent Channel Power Ratio, *ACPR*.

In modern Wireless Communication Standards, where higher data rates are used, the linearity is specified by *EVM* instead of *IMD*. Due to the nonlinearity of the PA, intermodulation terms will be produced and will coincide with the main signal causing deviation in magnitude and phase. The deviation vector that is drawn on the constellation diagram of the data points at the output of the PA is what is known as the *EVM* (see Figure 2). The *ACPR* is also important and is measured as the ratio between the Power leakage into the adjacent Channels to the useful signal power at the output of the PA.

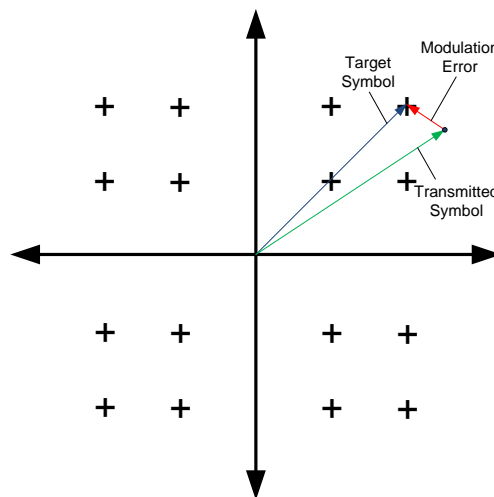

Figure 2: Error Vector Magnitude.

1.2 Intermodulation Distortion

In order to be able to model and consequently linearize a PA, it is important to understand how intermodulation nonlinearities are generated at its output. The Pin-Pout transfer function of PA is usually linear for low input power levels and then starts saturating for power levels higher than the P1dB as shown in Figure 3. This is another representation of the AM-AM curve that was shown in Figure 1.

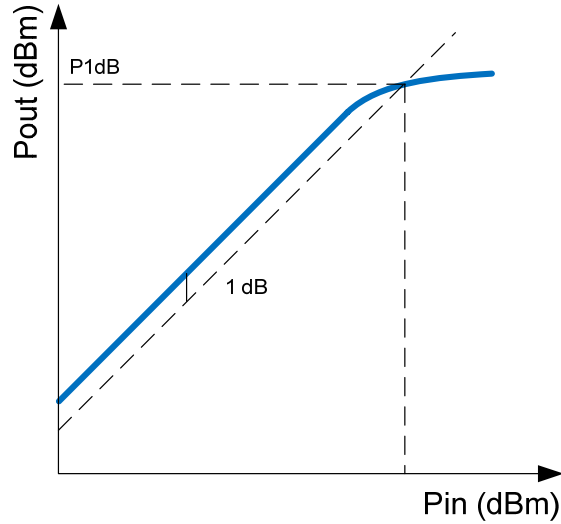

Figure 3: Pout vs. Pin of a representative PA.

Mathematically this nonlinear transfer function could be modeled as series expansion of power terms forming what is called a Power Series [1]:

$$v_{out} = a_1 v_{in} + a_2 v_{in}^2 + a_3 v_{in}^3 + \dots \quad (1.3)$$

In order to characterize the nonlinearity of the PA we use two tone test where we apply two input tones with relatively small frequency separation and we measure the output. So the input signal will be in the form of:

$$v_{in} = v \cos(\omega_1 t) + v \cos(\omega_2 t) \quad (1.4)$$

Then the output will be:

$$\begin{aligned} v_{out} = & a_1 [v \cos(\omega_1 t) + v \cos(\omega_2 t)] \\ & + a_2 [v \cos(\omega_1 t) + v \cos(\omega_2 t)]^2 \\ & + a_3 [v \cos(\omega_1 t) + v \cos(\omega_2 t)]^3 + \dots \end{aligned} \quad (1.5)$$

The first term is the main signal or the zero order term, the second one is the second order term, the third one is the third order term, and so on.

Now, for simplicity, We will consider only the first three terms of (1.5), and by applying some of the basic trigonometric relationships we could easily find out that the output will consist of different components as shown in Figure 4.

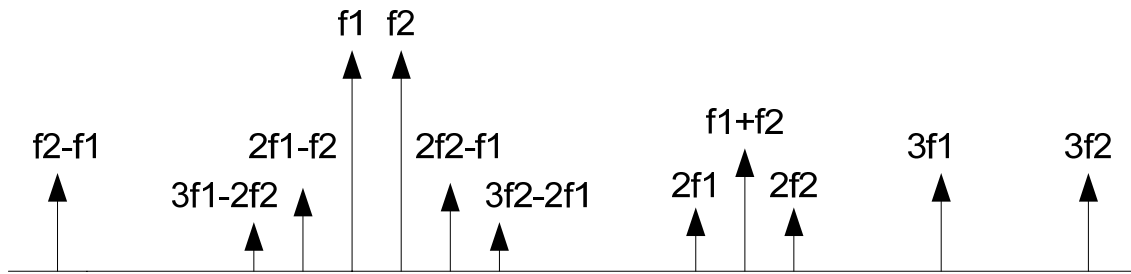

Figure 4: PA output spectrum when excited by two tones at f_1 and f_2 .

So all of the terms could be easily filtered out except for $2\omega_1-\omega_2$, $2\omega_2-\omega_1$, $3\omega_1-2\omega_2$ and $3\omega_2-2\omega_1$ which will fall in band very close to the main signal and cannot be filtered out. The first two terms are referred to as the third order intermodulation terms, IM_3 , and result from the interaction or the mixing of the second harmonic of one frequency with the other one. Whereas the second two terms are referred to as the fifth order intermodulation terms, IM_5 and result from the mixing of the third harmonic of one frequency with the second harmonic of the other one: $3\omega_2-2\omega_1$ and $3\omega_1-2\omega_2$.

For moderate nonlinearities the higher order terms are usually of smaller contribution than the lower order ones, and consequently IM_3 will have a more significant contribution to the total nonlinearities generated at the output of the PA than IM_5 , IM_7 and so on. That is why most of the PA are characterized by its IMD_3 level rather than IMD_5 or IMD_7 , where the IMD_3 is the ratio between the IM_3 and the output power at a certain output power value:

$$IMD3 = 10 \log \left[\frac{IM3 @ P_{out}}{P_{out}} \right] \quad (1.6)$$

Now, it is important to understand the relationship between amplitude of the IM terms (IM3, IM5, IM7, ...) and the main output power. The IM3 is generated due to the third term of (1.5), so in a dB scale vs. the input power, it will have a slope of 30 dB/decade. In the same way the IM5 will have a slope of 50 dB/decade, the IM7 will have a slope of 70 dB/decade and so on. However the Pout-Pin relation has a slope of 10 dB/decade as shown in Figure 5. So, at low input power levels the PA is very linear and the second and higher terms of (1.5) could be neglected, and that is why the IM terms start at a very low power level as compared to Pout. But since the IM3 for instance has a three times higher slope than the output power the difference between the two curves will decrease when Pin increases resulting in lower IMD3 for higher input powers. In addition if we extend the Pout and the IM3 lines linearly beyond the compression point they intersect at a power level known as the output Third order intercept point or OIP3 (if it is referred to the input it is called IIP3).

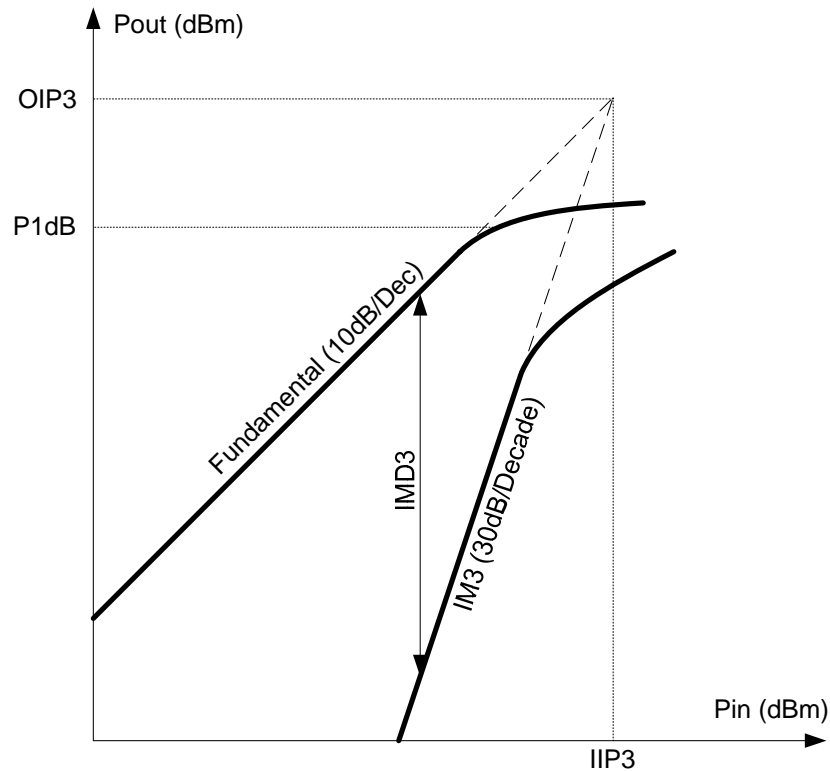

Figure 5: Pout of Fundamental and IM3 vs. Pin.

Once the OIP3 is known for a PA the IMD3 could be calculated at each power level as follows:

$$\begin{aligned} IMD3 &= 2[P_{out} - OIP3] \\ &= 2[P_{in} - IIP3] \end{aligned} \quad (1.7)$$

Note that this relation is only correct for low power where both the Pout and IM3 curves are linear.

The above Power Series analysis is very important to understand the nonlinearities of a PA. However since it assumes magnitude only for each degree of nonlinearity in (1.5), i.e. a_1, a_2, a_3, \dots etc. have a phase of either 0 or π only, it cannot predict AM-PM behavior. So a more general analysis that assumes general phase angles for the different coefficients is the Volterra Series [2]. In this case both the AM-AM and the AM-PM curves of a PA could be predicted.

1.3 Linearization Techniques

The major tradeoff in PA design is between Linearity and Efficiency. Without applying any of the Linearization technique, a *Backoff (BO)* is required to achieve higher linearity. To backoff means to operate the PA at a power level lower enough than its 1 dB compression point to achieve the required linearity:

$$BO = P_{1dB} - P_{out} \quad (in \text{ dB}) \quad (1.8)$$

This concept could be easily understood by looking at (1.7) where we notice that a lower Pout, resulting from higher BO, will result in higher magnitude of IMD3 and consequently more linear operation of the PA.

However for a simple Class A PA, where the DC power is assumed to be almost constant at different power levels, and by looking at (1.1), we can see that lower Pout means lower efficiency. This is also true in general for other PA classes.

So it is important to apply smarter ways of linearization other than Backoff in order to operate the PA at higher Pout for higher efficiency without sacrificing Linearity. Different linearization techniques have been suggested and used to achieve that. All of these techniques could be classified into three main categories:

- Feedback
- Feedforward
- Predistortion

Different design factors should be evaluated in order to decide what linearization technique to use. These factors include: Complexity, Cost, Reliability, Linearity, Bandwidth, Efficiency, ...etc.

1.3.1 Feedback

In a typical amplifier with a negative feedback, the output signal is compared to the input to calculate the error, then this error is fed back to the input in order to minimize the difference between the input and the output. So if we consider the intermodulation terms generated at the output of a PA as an error, then the same technique could be applied to linearize its performance. However, at microwave frequencies, the stability of a PA with negative feedback becomes a great challenge. In order to have a PA with low intermodulation levels, a feedback loop that has high enough gain but low enough phase shift is required to ensure stability. This is very difficult to be achieved at such high frequencies over adequate bandwidth because the phase changes very fast.

Since the PA input signal is composed of a high frequency carrier modulated by low frequency envelope, a solution to the stability problem is to apply the feedback to the envelope of the signal rather than the signal itself. This is implemented in the Polar loop linearization technique [2] shown in Figure 6, where the output is first down converted to IF frequency, then both the amplitude and phase are compared to correct for AM-AM and AM-PM errors respectively. The error in amplitude is simply accounted for by using an

Automatic Gain Control circuit (AGC), whereas the error in phase is accounted for by using a Voltage Controlled Oscillator (VCO).

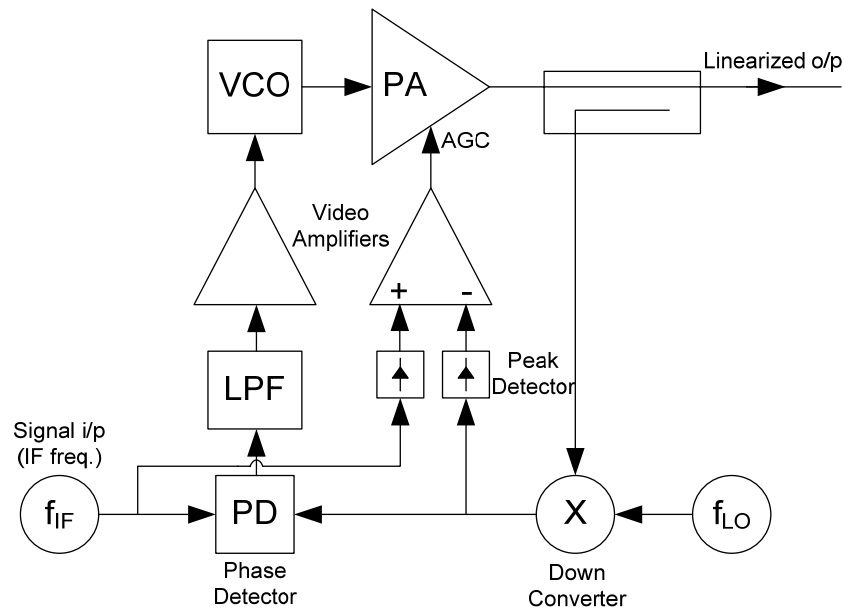

Figure 6: Polar Loop Linearization.

Although great linearity could be achieved with Polar Loop systems, the bandwidth requirement of the amplitude and phase error amplifiers limits its use for low bandwidth applications. Also the correction for the phase by using a VCO in a feedback loop makes the design very complex as it becomes more like the design of a Phase Locked Loop (PLL) system.

Another approach that has some advantages over the Polar Loop systems is the Cartesian Loop shown in Figure 7. In this technique, the amplitude and phase errors are accounted for by correcting two Quadrature channels I and Q. This makes life much easier since the I and Q signals are already available in most of the modern digital systems in the IF frequency. So the I and Q portions of the signals are up converted, and then a portion of the output signal is down converted back to IF, and compared to the input using two video amplifiers.

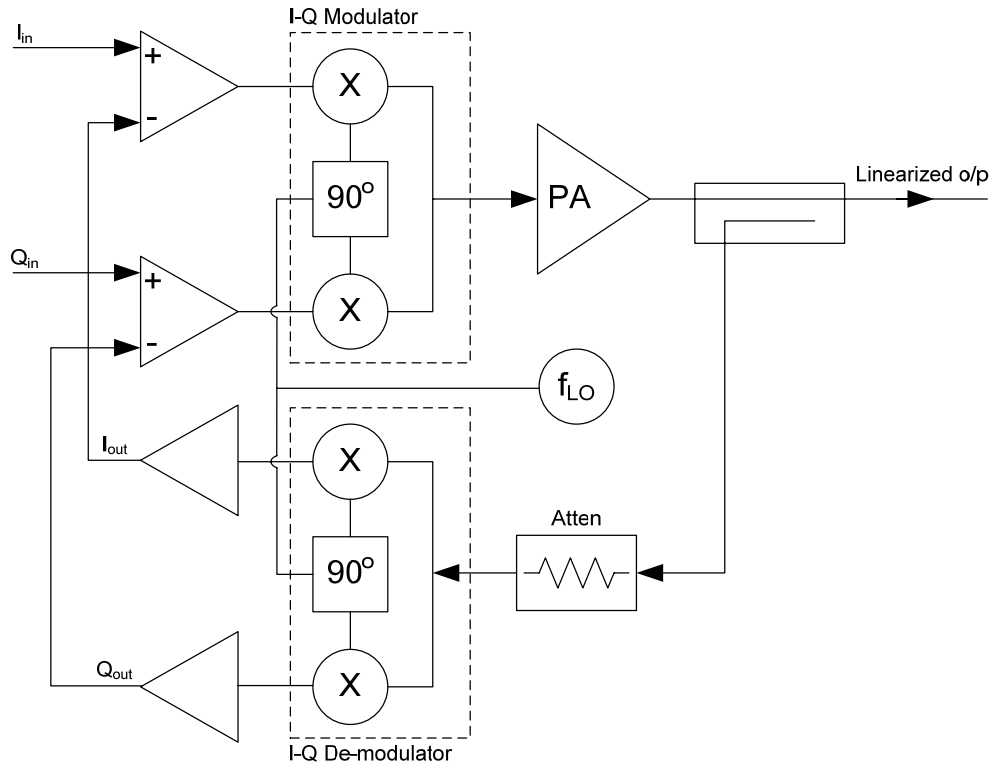

Figure 7: Cartesian Loop Linearization.

So in Polar and Cartesian Loop systems high linearity could be achieved over different temperatures and process variations, which is the beauty of Feedback systems, however the system complexity is high and consequently the cost is high too. Also the bandwidth limitation makes it not suitable to high data rate communication systems.

1.3.2 Feedforward

Feedforward has the same concept of operation as Feedback except that the error signal, resulting from comparing the output to the input, is applied to the output rather than to the input of the amplifier. This solves the problems of instability and low bandwidth associated with Feedback systems.

Figure 8 shows a basic configuration of a Feedforward system [3]. The way it works is that a portion of the output signal is compared against a delayed input using a 180

degrees combiner, where the delay is necessary to compensate for the delay from the main PA on the other signal path. Then this error is amplified to the proper level and fed to the output in the proper phase so as to obtain an intermodulation or Error free output. Again another delay is required to compensate for the delay from the Error Amplifier.

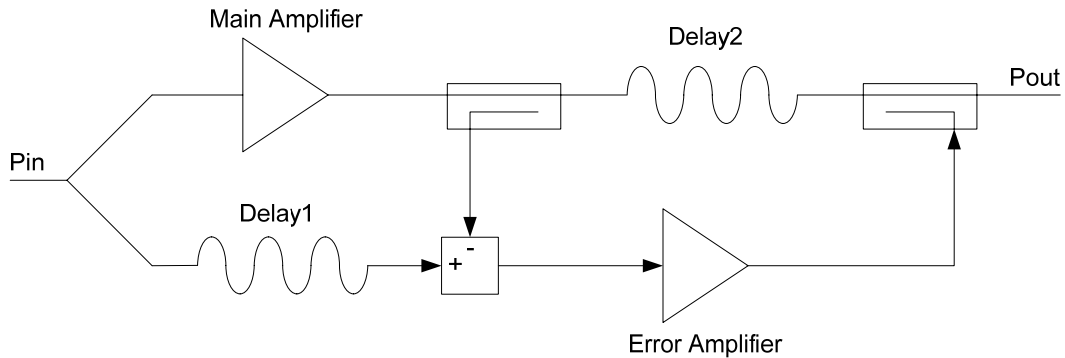

Figure 8: Feedforward Linearization.

Since Feedforward is an open loop system, it is vulnerable to temperature and process variations. So additional compensation and monitoring circuits are required to maintain good linearity over different conditions. This leads to a complex and costly system. Moreover Since the Error Amplifier is required to amplify the error signal to be subtracted from the output, it is very important for this amplifier to be very linear, otherwise unwanted nonlinearities will be added to the output. This makes the EA very inefficient degrading the whole efficiency of the Feedforward system.

1.3.3 Predistortion

The basic concept of Predistortion Linearization, as its name implies, is to predistort the input of a PA in an opposite way to its distortion in order to get a linear output. This is shown in Figure 9, where an ideal predistorter should have an AM-AM and AM-PM characteristics opposite to those of the PA being linearized.

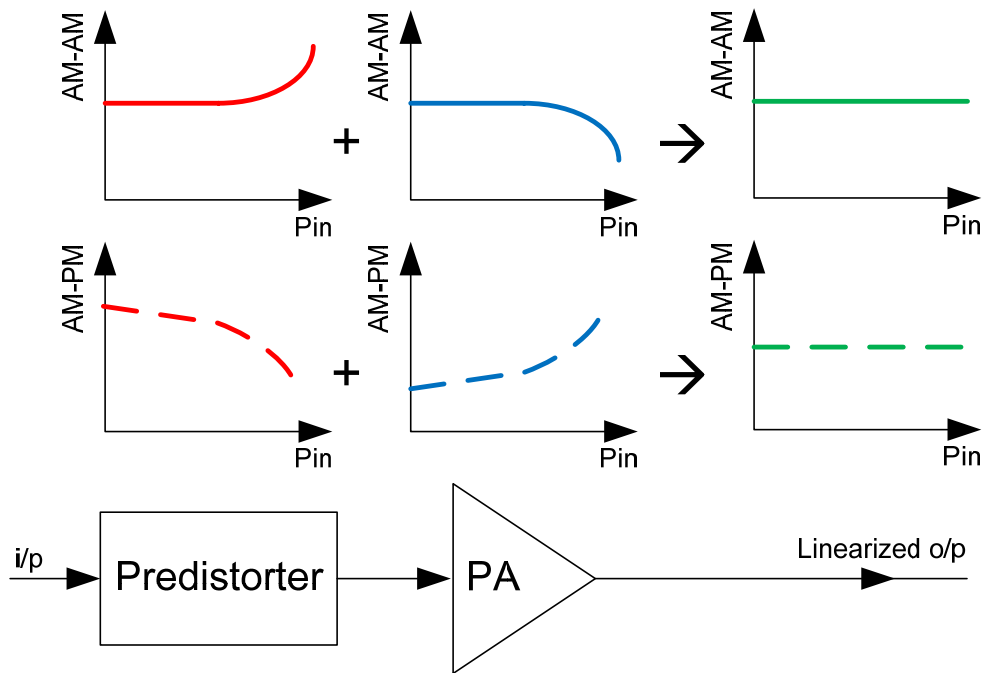

Figure 9: Predistortion Linearization.

The realization of that ideal predistorter is impossible, however the more accurate it is required to be, the more complex design it will have. The simplest designs use a series diode [4] as shown in Figure 10. Since the diode could be modeled as a resistor that has a lower value with higher input derive levels, it will have a gain expansion curve that could compensate for the gain compression of the PA being used. In addition it will have a phase compression that can partially cancels that of the PA. The design parameters of this configuration are the diode bias and size. The problem with this configuration is that it is very difficult to compensate for both AM-AM and AM-PM on the same time, also it is very hard to have this compensation over the entire input power range, and that is why the linearity enhancement that was reported is very limited.

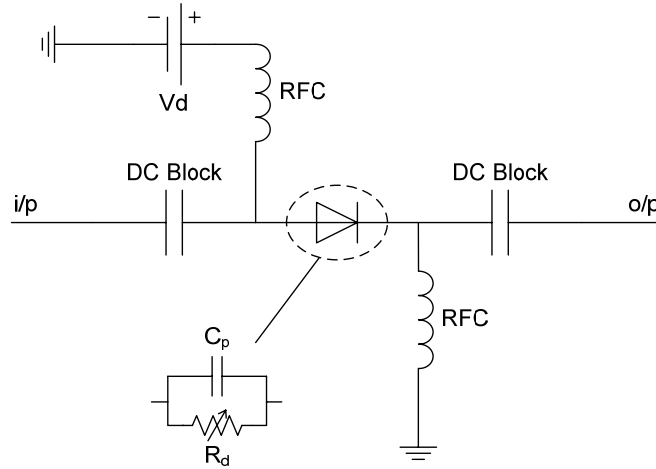

Figure 10: Simple series diode predistorter.

Another predistortion technique is to use what is called a cubic predistorter circuit [5]-[6], where third intermodulation is being generated at the input of a PA and then fed in the proper phase so that it cancels the third intermodulation at the output as shown in Figure 11. The problem with that technique is that by feeding more nonlinearities (third intermodulation component) at the input of an already nonlinear PA, it will generate more fifth intermodulation terms at the output. This results in a PA that has nonlinearities dominated by the fifth and higher intermodulation terms that limit the linearization that could be achieved with this technique.

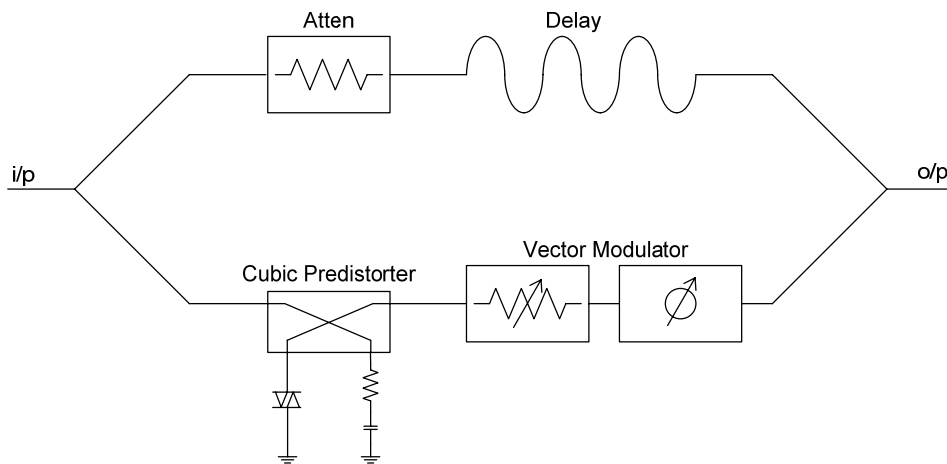

Figure 11: Cubic Predistorter.

As a solution to the increased fifth and higher intermodulation terms in the cubic predistorter technique, it was suggested in [7]-[9] to use another cubic predistorter circuit that can cancel the fifth intermodulation independently as shown in Figure 12. So again the same problem will be an increased seventh and higher nonlinearities, but this time with less effect on the overall enhancement in linearity.

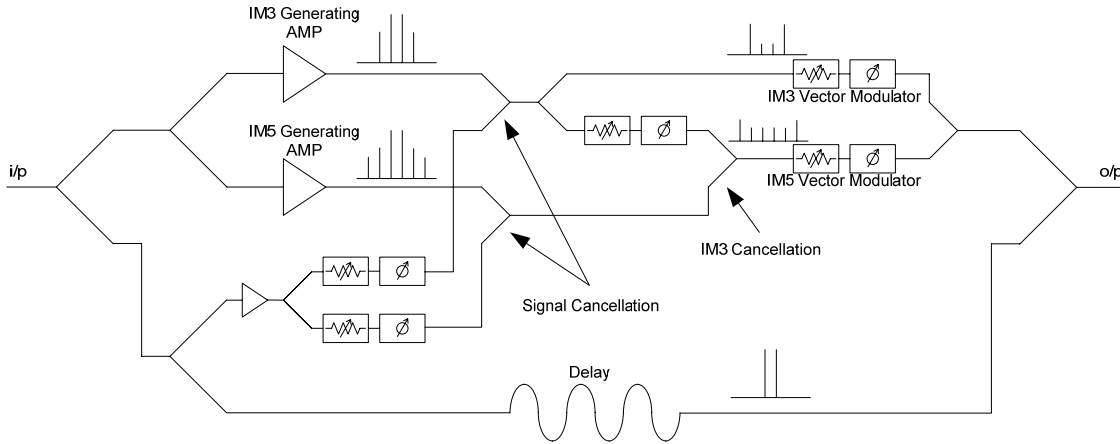

Figure 12: Predistorter used in [7] to cancel both IM3 and IM5 simultaneously.

Moving from using one cubic predistorter circuit to two, the complexity of the design becomes an overkill. Moreover, in order to cancel the fifth and higher intermodulation terms at the output of a PA, a precise measurement of their amplitude and phase is needed in advance in order to set initial values for the vector modulators used in the design, otherwise tweaking all these different design parameters to cancel the nonlinearities will be a nightmare. In addition to the complexity and tuning difficulties, the dependency on temperature and power is a bigger problem. Since the cubic predistorter is an independent circuit from the PA, it will have different variations with temperature and input power level. This will significantly limit the temperature range of operation and will also degrade the enhancement in linearity as the PA being driven harder into compression.

In the work done in [10], it was suggested to use an additional capacitor in the cubic predistorter circuit to reduce the complexity. By tuning this capacitor the phase difference

between the third and fifth IM's could be adjusted to reduce both the IM3 and IM5 at the output of the PA without using an additional cubic predistorter circuit as shown in Figure 13. So the problem of complexity has been resolved in this configuration, however the dependency on temperature and power is still unresolved.

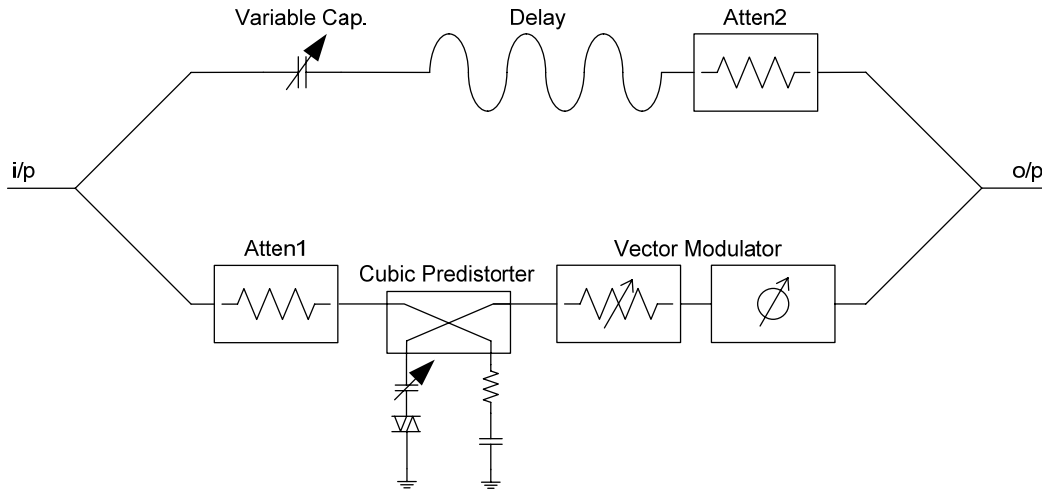

Figure 13: Predistorter suggested in [10].

All the techniques discussed above fall under the category of Analog predistortion techniques, where analog circuits are used at the RF frequency to correct for the AM-AM and AM-PM nonlinearities of a PA. Although those techniques are very fast, precise tuning and temperature and power dependency issues limit their use. Digital predistortion offers good solution for those two issues.

First of all, since the AM-AM and AM-PM of a PA could be measured and recorded at different input power levels, they could be compensated for by using a power detector and a Look Up Table (LUT) as shown in Figure 14. The power detector detects the input power level and based on the recorded PA performance a LUT will select the proper phase and amplitude adjustments at the input of the PA.

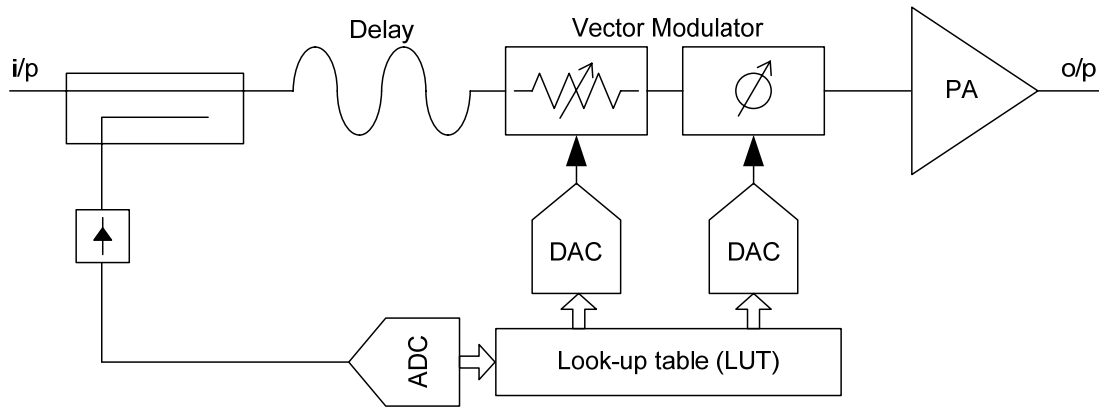

Figure 14: Digital Predistortion Linearization.

However the dependency on temperature and power remains a problem. So a possible solution is to use Adaptive digital predistortion technique [3] where a Feedback, Digital Signal Processing (DSP), and up and down conversions are used to control the signal at the baseband rather than at the RF with higher precision and with less dependency on temperature and power. All those benefits comes unfortunately at the cost of complexity and cost.

1.4 Thesis Outline

Different linearization techniques were presented and discussed in this chapter. So based on that a new linearization technique called “Mirror Predistortion Linearization” will be presented and described in the second chapter along with simulation results and a lab implementation that proofs that the concept works properly. After that in the third chapter a hybrid module implementation of the proposed technique is presented and all the implementation details and the difference between this implementation and the first lab implementation will be addressed. In the fourth chapter measurement results will be presented and discussed. Finally we will conclude the work in Chapter five along with suggestions for future work.

Chapter 2

Mirror Predistortion Linearization

One of the most powerful linearization techniques that was discussed in the previous chapter is Feedforward linearization. However the main problems with that technique are: efficiency degradation due to a use of a big Error Amplifier that could be as big as the main PA, and the need for an automatic control circuitry to correct for temperature and process variations.

In order to improve the efficiency predistortion techniques could be used instead where a low power predistorter circuit is added before the PA to correct for both AM-AM and AM-PM nonlinearities. To be able to achieve that a priori full characterization of the main PA is required. In other words both the phase and magnitude of the IM3, IM5 and all the higher nonlinearities need to be measured. There are full papers written on that subject since it is an issue by itself [11]-[12].

As a compromise between the Feedforward and the Predistortion linearization technique, we propose a new linearization technique called: “Mirror Predistortion” linearization. The description, simulation and lab verification of this new method will be discussed in details in this chapter.

2.1 Method Description

A new linearization technique is proposed in this thesis. It aims to mitigate the deficiencies of both the Predistortion and the Feedforward by compromising between the advantages and disadvantages of both techniques. The new technique uses a low power mirror PA in front of the main high power PA. Therefore, it has the same distortion characteristics as the main PA, but at a much lower power level. Because this low power PA nonlinear characteristics “mirrors” the main amplifier nonlinear characteristics, we call this low power amplifier a “Mirror PA”. The third and higher intermodulation generated by the mirror amplifier (with proper phase and amplitude adjustments) is fed into main PA. This results in the intermodulation cancellation at the output of the PA. Because the mirror PA distortion characteristics is identical to the main PA, the intermodulation cancellation tends to be broad with power level, temperature and frequency .

Figure 15 shows the block diagram of the proposed Mirror Predistortion linearization technique. It is required to feed the intermodulation terms coming from the mirror PA to the main signal at the input of the main PA so that they cancel the intermodulation generated at the output. So the magnitudes of paths $ABDFHIK$ and $ACJK$ have to be equal whereas the phases have to be 180° shifted. Both the magnitude and the phase are controlled by *Vector Modulator 2*. Also we need to ensure that this phase shift of 180° is achieved across a broad bandwidth , and that is why *Delay 2* is used to make sure both paths have the same delay.

Moreover it is required to cancel the carrier coming out from the mirror PA. This is done by adding path EG to path DF with the same delay and magnitude but 180° out of phase. Again this is controlled by using *Vector Modulator 1* and *Delay 1* to get broadband cancellation. Any carrier leakage at point H will result in reduced gain since paths $ABDFHIK$ and $ACJK$ are 180° out of phase, and also will result in non optimum predistorter tracking to the AM-AM and AM-PM of the main PA.

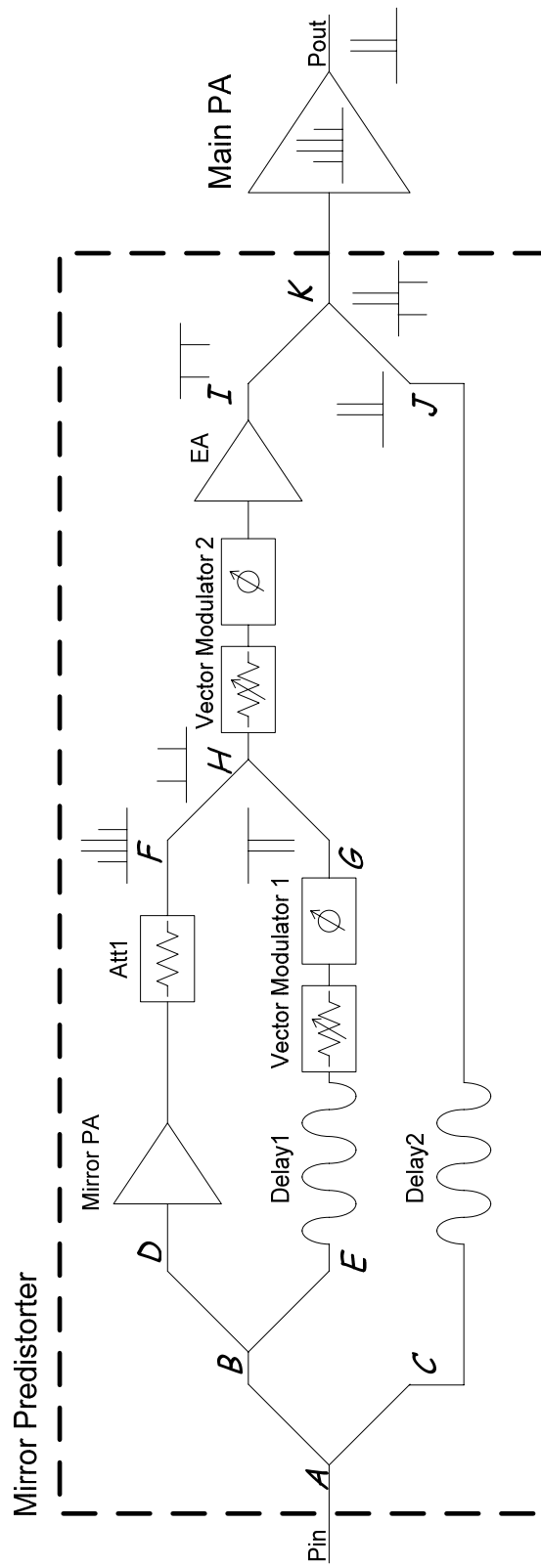

Figure 15: Mirror Predistortion Linearization.

By feeding the third and higher intermodulation terms at the input of the PA in the proper magnitude and phase, they will be amplified and appear at the output with the same magnitude but out of phase with the already generated intermodulation terms resulting in cancelling it. This is demonstrated in Figure 16 and is another way of looking into the same concept of AM-AM and AM-PM correction that was shown in Figure 9.

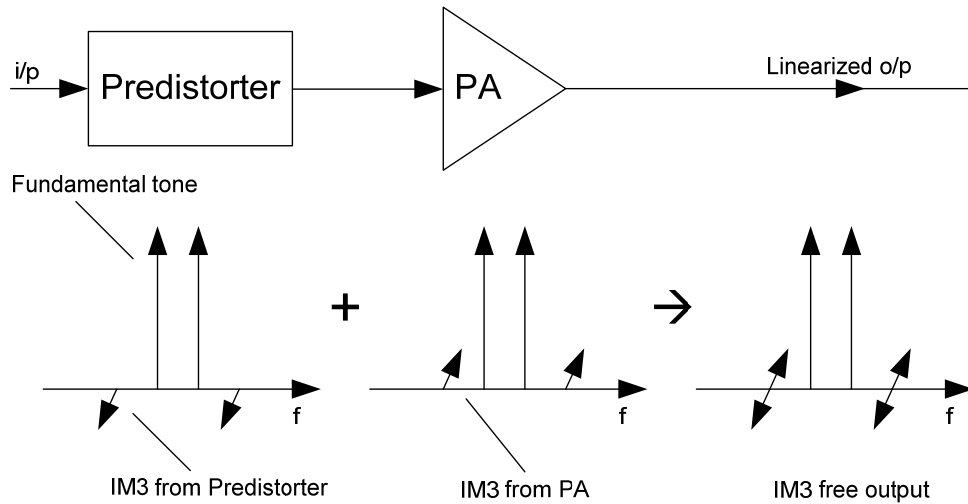

Figure 16: Intermodulation cancellation concept by using a Predistorter.

The main advantage of the Mirror Predistortion over Feedforward linearization is that the size of the Error Amplifier (EA) could be much smaller in terms of size and power consumption. This is accomplished by feeding the intermodulation terms at the input of the PA rather than its output. So the power requirement of the EA is simply less by the gain of the main PA. Moreover by designing the coupling ratio of coupler *IKJ* shown in Figure 15 we can farther decrease the requirement on the output power of the EA. By doing so, however, the total loss of the predistorter will increase. For instance if we are using a 10 dB coupler instead of a 3 dB coupler, we will get 7 dB higher in the total loss of the predistorter. Fortunately the total gain of the PA with the predistorter could be boosted by using a low power driver amplifier before the predistorter.

In addition by comparing the Mirror Predistorter to the other predistorter configurations discussed in the previous chapter as the one shown in Figure 12, we notice that it is much simpler and easier to tune and implement. This is noticeable in using two vector modulators only and much fewer number of couplers in the Mirror Predistorter as compared to the other methods. Also on the other methods a full nonlinear characterization of both the PA and the predistorter is required in order to get good cancellation of the IM products at the output while in the Mirror Predistorter this is not needed. Moreover we get better tracking and linearization for higher output power levels as compared to the other techniques.

Now we need to get a mirror PA that has the same nonlinear characteristics of the main PA but with smaller size and power. This could be achieved by building the main PA from smaller PAs combined together by power dividers and combiners and use one of those small PAs as a mirror PA. This is shown in Figure 17 for a special case where 4 PAs are combined to act as the main PA. In that example the wasted power in the mirror PA will be only $\frac{1}{4}$ of the total dissipated power in the main PA. Relatively lower wasted power in the mirror PA could be achieved by combining more PAs and consequently will improve the overall efficiency of the PA.

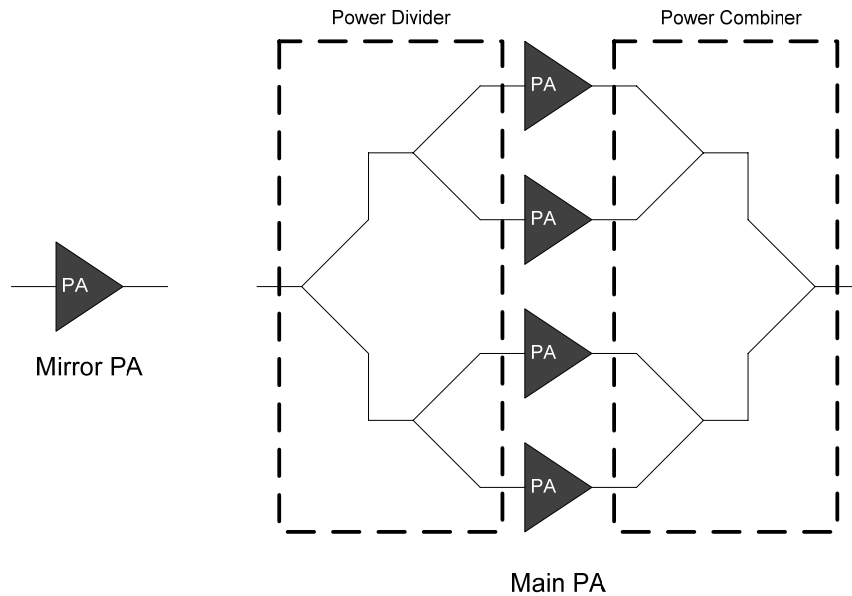

Figure 17: Realizing a Mirror PA that has the same nonlinear characteristics as the main PA.

2.2 Simulation Results

Agilent ADS 2008 Update1 was used to simulate the performance of the suggested Mirror PD linearized PA. The schematic is shown in Figure 18. Ideal components were used for the attenuators and phase shifters to speed up nonlinear simulations. *ATTN_1* is used to make the input power level of the mirror PA equal to that of the main PA. *PS_A* and *ATTN_A* are used as the phase shifter and the variable attenuators of *Vector Modulator 1*; while *PS_B* was used for *Vector Modulator 2* along with the gain of the ideal EA: *AMP_1*. A nonlinear model was used for the AMCOM AM204437WM-BM MMIC and S-parameter files were used for the Anaren 3-dB and 10-dB couplers.

Four AM204437WM-BM MMIC's were used to construct the main PA, while one more was used as the mirror PA. The simulated P1dB of the PA is 40 dBm which is lower than the expected value of 42 dBm. This is because of inaccuracy in the ADS converted model. However the model could still be used to compare the nonlinear PA performance with and without linearization. *ATTN_3* was used after the EA to turn OFF (100 dB attenuation) and ON (0 dB attenuation) the linearization. Since no delay components were used to speed up the simulation time, the spacing between the two tones input was limited to 1 MHz. Figure 19 shows the main nonlinear schematic that was used to test the nonlinear performance of the PA.

Figure 20 shows the simulated IMD3 vs. output power (Pout) with and without linearization. An improvement of 38 dB in the IMD3 is achieved at 10 dB Back Off (BO), whereas an improvement of 8 dB is achieved at 4 dB BO. An improvement in the IMD5 of 10 dB was also achieved at different Pout values but it degrades at higher power levels with no improvement at 1.5 dB BO. Since the main goal of linearization is to be able to operate the PA at higher power levels with the same linearity to increase the efficiency, the efficiency vs. linearity (IMD3) is plotted in Figure 22 with and without linearization. We notice in this curve an improvement in efficiency of 4 times and higher for IMD3 level of -50 dBc and lower. However at higher IMD3 values the improvement in efficiency degrades and becomes zero at an IMD3 level of -30 dBc.

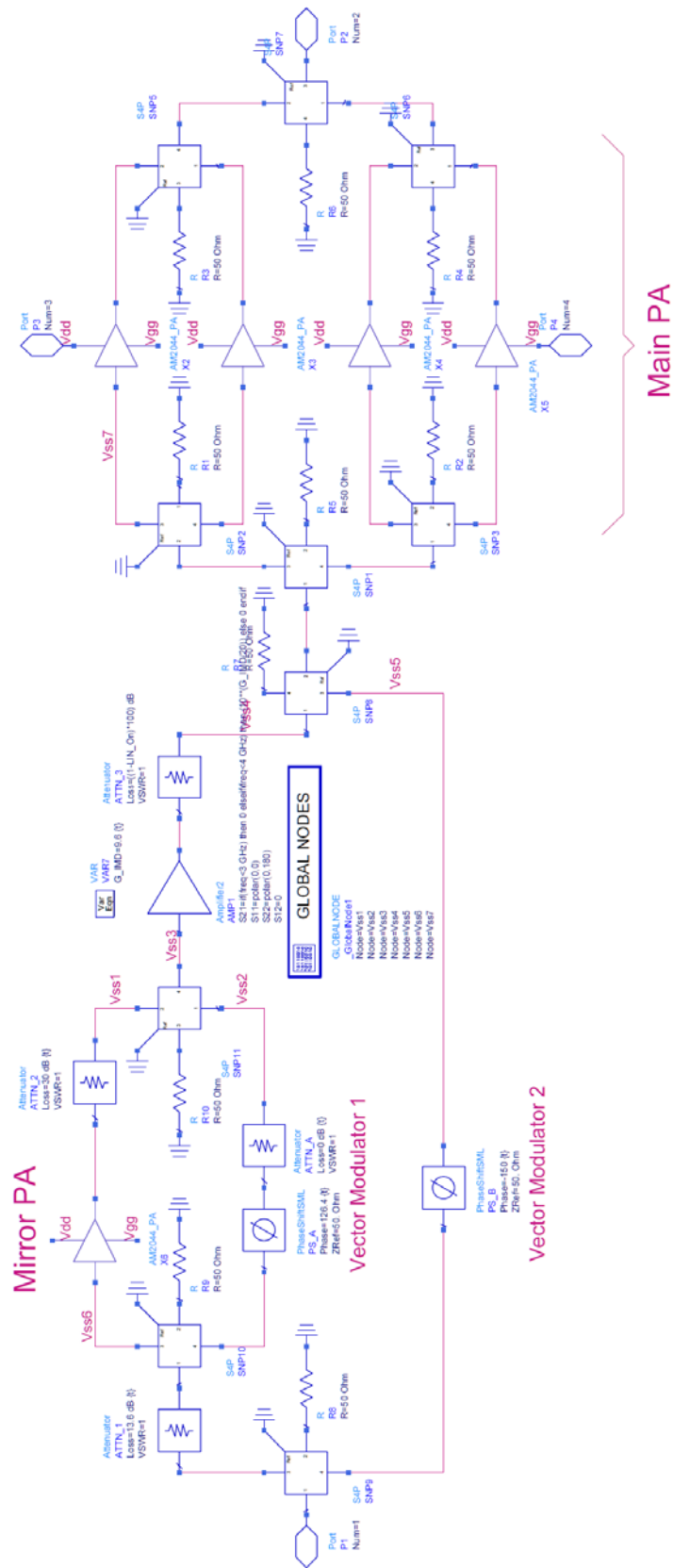

Figure 18: ADS Mirror PD linearized PA Schematic.

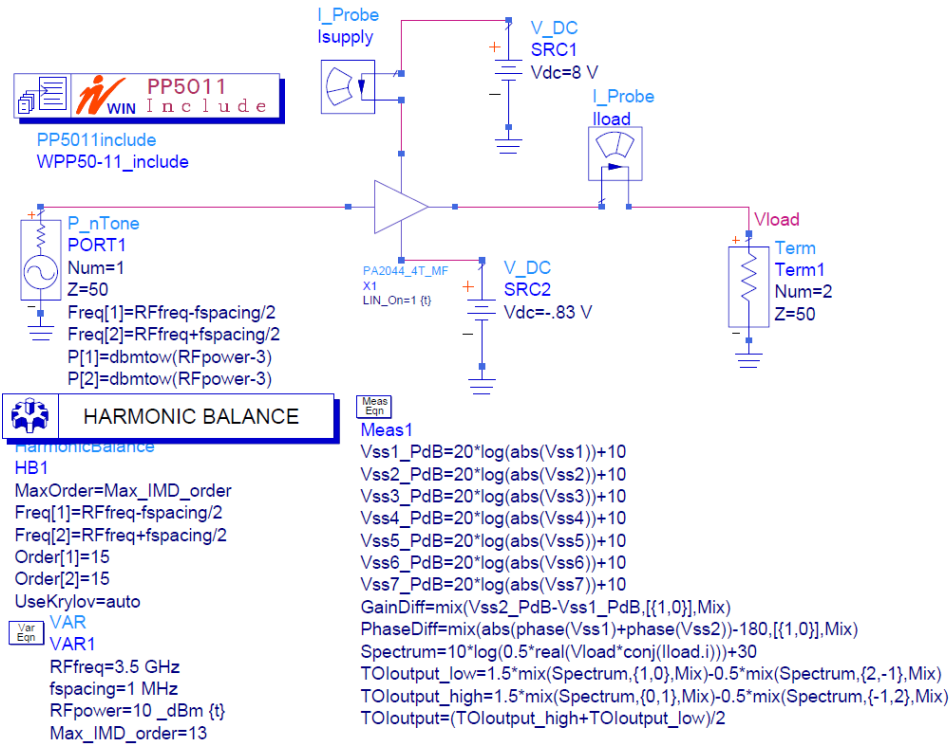

Figure 19: Intermodulation and Efficiency testing schematic on ADS.

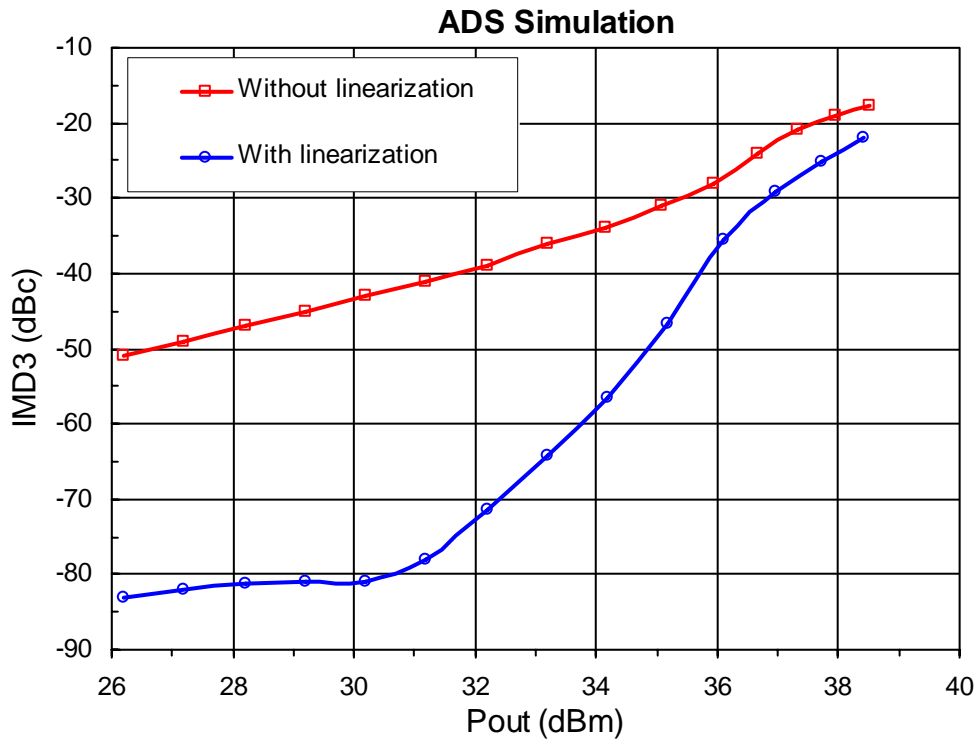

Figure 20: Simulated IMD3 vs. Pout with & without linearization.

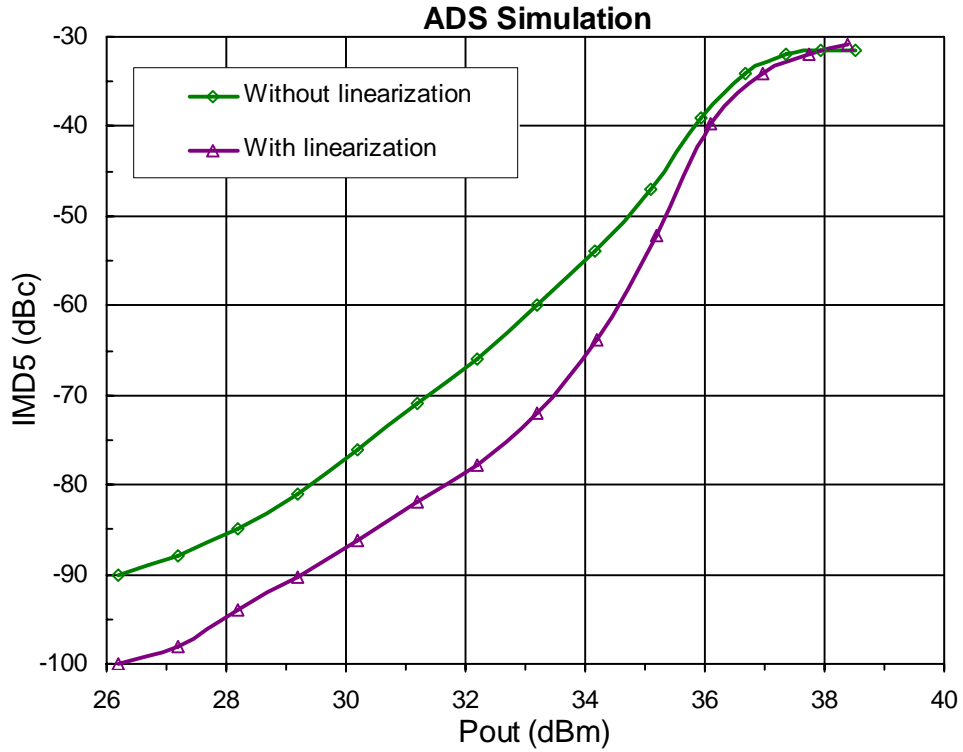

Figure 21: Simulated IMD5 vs. Pout with & without linearization.

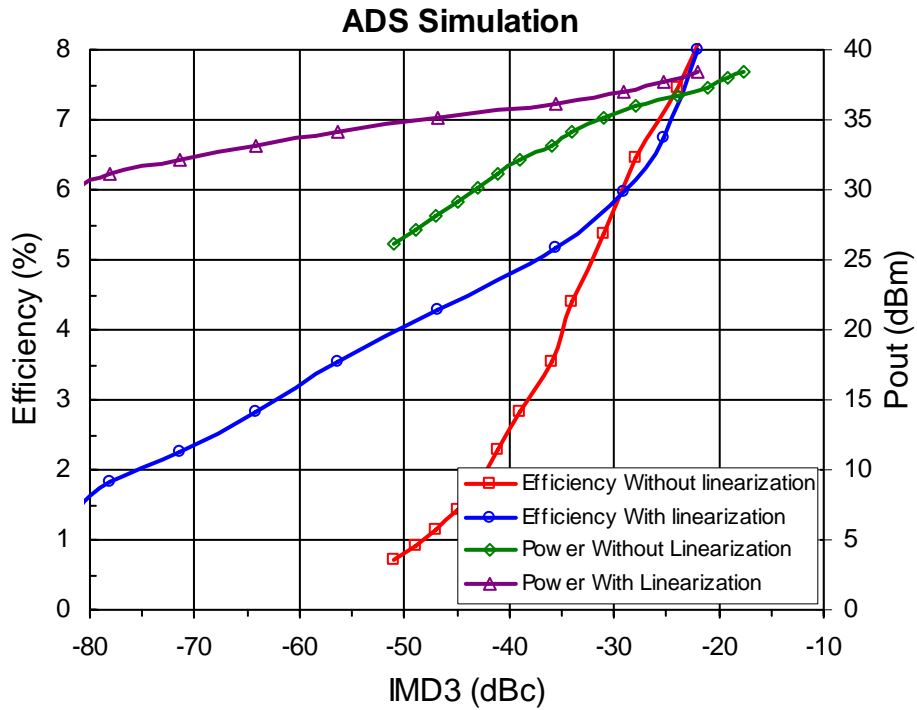

Figure 22: Simulated Efficiency & Pout vs. IMD3 with & without linearization.

The reason for the efficiency with linearization to become lower than the efficiency without linearization at IMD3 levels higher than -30 dBc is that the improvement achieved at those levels does not justify for wasting power in an extra PA for the mirror.

So the question now is: Why does the performance of the linearized PA degrades at higher power levels?. There are two reasons for that degradation: First, when the power level is high the mirror PA starts compressing resulting in imperfect cancellation of the carrier in the PD circuit (Gain mismatch between paths DF and EG in Figure 15). This results in carrier leakage to the input of the PA and makes the AM-AM and AM-PM compensation non optimal. Second, it was assumed that the intermodulation terms (third and higher) being fed at the input of the PA will be amplified linearly and appear at the output of the PA in the proper magnitude and phase to cancel the intermodulation generated from the main PA internally. This assumption is true for low power levels, however at higher power levels the PA starts compressing in magnitude and expanding in phase making the compensation non optimal. Moreover the level of the intermodulation terms being fed at the input increase to a level that they start interacting with themselves and with the main input carrier generating more nonlinearities at the output.

Also we can notice that the improvement in the IMD5 is much lower than the improvement in IMD3 (approximately 10 dB vs. 30 dB and more for the IMD3). This is again due to the same reason that the IMD3 fed to the input of the PA will interact with the main carrier and with itself generating more IMD5 and higher nonlinearities making the IMD5 compensation non optimal. However we should not worry about that since the level of the IMD3 after linearization remains higher than the IMD5 at all P_{out} levels as we can see from Figure 20 and Figure 21.

2.3 Lab Implementation

The ultimate goal of the thesis is to build a hybrid module linearized PA using the new proposed concept of Mirror Predistortion where AMCOM MMIC's could be used for that purpose. Since doing so costs a lot of money and time, it is important to do a quick experiment in the lab and take some measurements for the linearity and efficiency to verify the proposed linearization concept. This could be done using connectorized components as shown in Figure 23. Vector modulators 1 and 2 are implemented by using variable phase shifters and attenuators that could be varied with a screw driver. AMCOM Module AM204437SF-3H is used as the mirror and main PAs. Although a smaller PA could be used for the EA, the same high power AM204437SF-3H module was used to make sure that it is not generating any additional nonlinearities into the input of the main PA.

Since it is hard to equalize the delays of the different paths by using the available SMA cables in the lab, the implementation was limited to a very narrow bandwidth. So in the two tone test a separation of 100 KHz only was used between the tones. Moreover, for simplicity, a ratio in size between the mirror and main PA of 1:1 was used. So since we are using the same module also for the EA, we have an overhead in power of 3:1, i.e. we are wasting three times as much DC power when the linearization is ON.

The measurement shows an improvement in the IMD3 of 30 dB at 29 dBm output power which is 7 dB BO from the P1dB power of 36 dBm (see Figure 24). However this improvement degrades at lower and higher power levels. In addition to the degradation reasons discussed before in the simulation results, the mismatch between the main and mirror PAs, that was not considered in simulation, is another reason for bad tracking of the linearization with different power levels. Also this mismatch is obvious in the low improvement obtained in IMD5 (approximately 5 dB as compared to 10 dB in simulation) as shown in Figure 25. Note that below 30 dBm output power, the level of the IM5 was below the sensitivity of the spectrum analyzer making the measurement of IMD5 in that range not reliable. The efficiency vs. IMD3 is plotted in Figure 26 where an

improvement in efficiency is obtained (although three times the main PA power is used) up to an IMD3 level of -40 dBc.



Figure 23: Lab setup for the Mirror PD linearized PA. Photo by author, 2009.

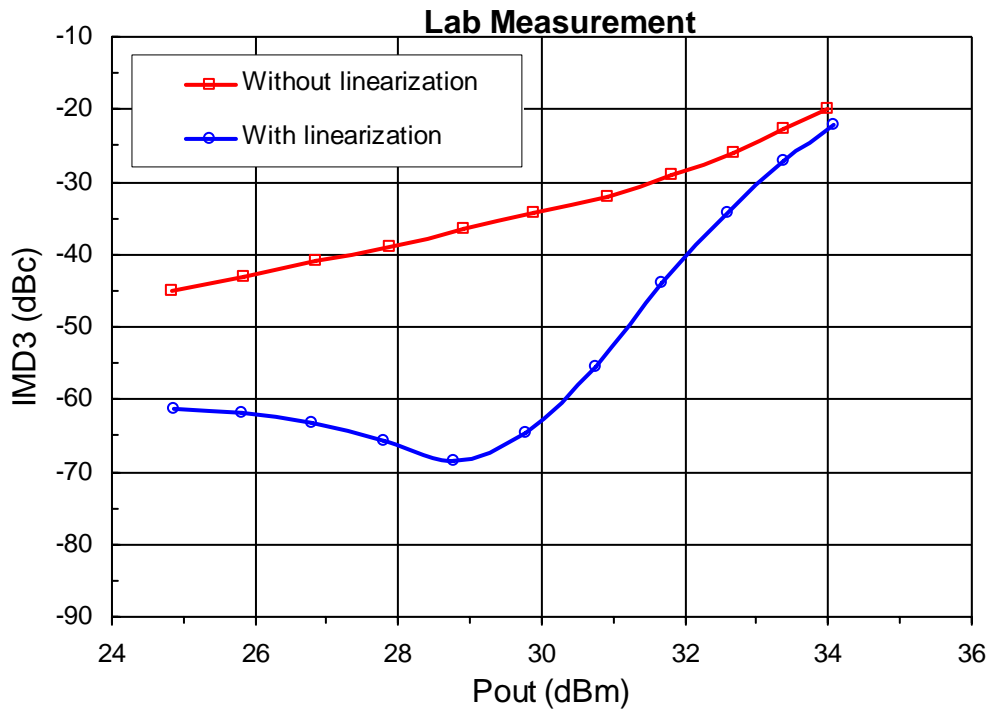

Figure 24: Lab implementation measured IMD3 vs. Pout with & without linearization.

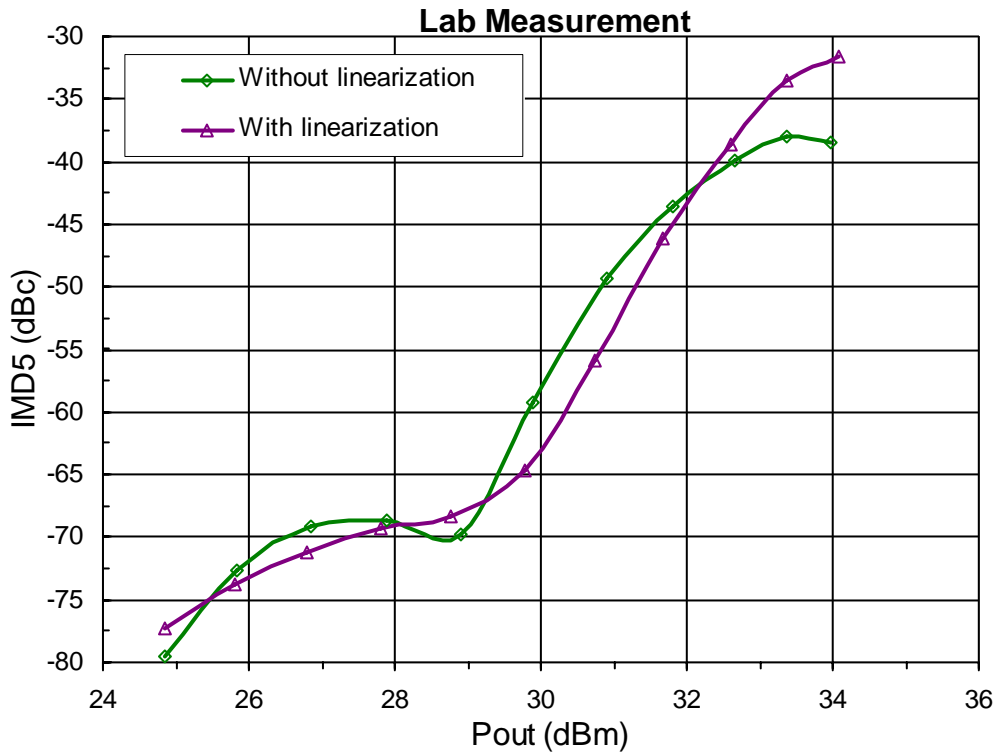

Figure 25: Lab implementation measured IMD5 vs. Pout with & without linearization.

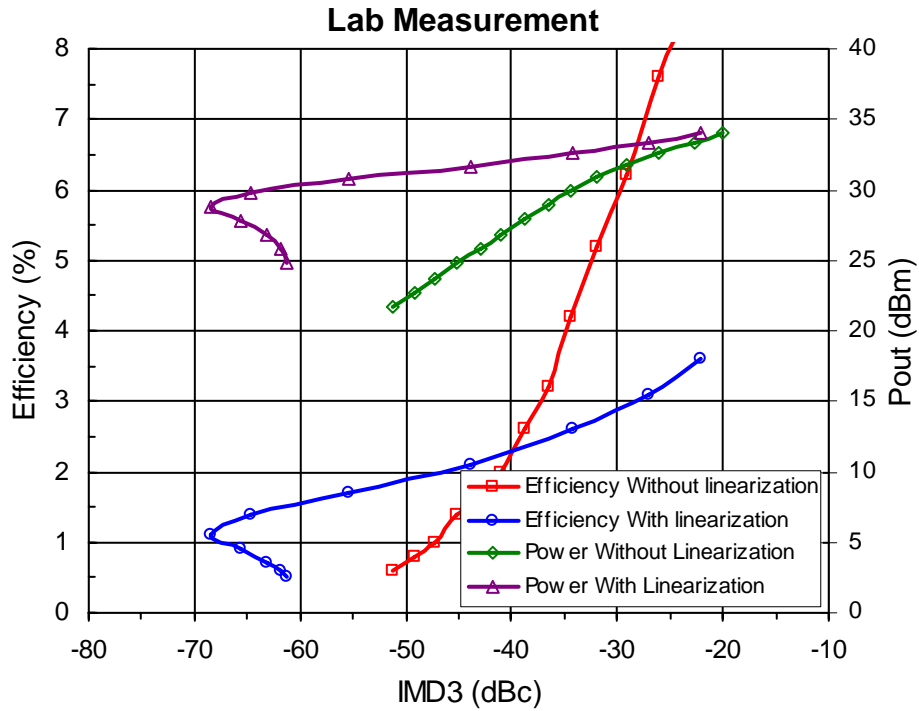

Figure 26: Lab implementation measured Efficiency & Pout vs. IMD3 with & without linearization.

2.4 Summary

In this chapter a new linearization technique, “Mirror Predistortion Linearization”, was proposed. The concept was verified using ADS simulations and a quick lab implementation and measurements. For the ADS simulation, improvements of 38 dB in the IMD3 and 10 dB in the IMD5 were obtained at 10 dB BO, whereas for the lab implementation improvements of 30 dB in the IMD3 and 5 dB in the IMD5 were obtained at 7dB BO. In the next chapter a hybrid module that applies the new linearization technique will be designed.

Chapter 3

Hybrid Module

After trying the new “Mirror PD Linearization” technique in simulation and in the quick lab setup, it is time to integrate the whole linearized PA into one hybrid module. In this hybrid module, all the different components could be assembled on one Printed Circuit Board (PCB) that uses high frequency dielectric material that could work for RF applications. The PCB could be mounted inside an aluminum box for heat dissipation and protection, with the connection to the input and output done by using RF SMA connectors.

The importance of this integration is to reduce the new technique into practice and make it easy for integration with other elements of wireless systems. In order to so, small size Surface Mount (SMT) components have to be used along with small packaged MMIC's for the EA and the mirror and main PAs. This means that no connectorized components, like those used for the variable attenuators and phase shifters or the couplers in the lab experiment, could be used anymore. So the main challenges now are how to find the right components, how to integrate all that into a reasonably sized module with no coupling between components, and how to design it so that it is easy to tune to give the best possible linearity performance over a broad band of frequencies and power range.

3.1 Specifications

The WiMax wireless communications system standard uses OFDM for its signal modulation. OFDM modulation is known for its high PAR (can reach up to 15 dB), so it requires a very linear PA. So it will be very useful to design a linear PA that targets one of the WiMax frequency bands. We choose the 3.5 GHz frequency band for our design. Also we try to achieve an output power greater than 10 watts with the minimum possible nonlinearities at the output and the minimum possible size for the module housing with the SMA connectors for the RF input and output. A standard 8V regulated DC power supply will be assumed to be available for biasing.

3.2 Implementation

3.2.1 Components Selection

▪ Mirror and Main PAs

The AMCOM MMIC AM204437WM-BM works from 2 GHz to 4.4 GHz with a gain of 30 dB and output power of 36 dBm (4 Watts). So it is suitable for the WiMax 3.5 GHz band where the main PA could be built by combining four of these PAs for a total output power of 42 dBm (16 Watts). Then one more MMIC of the same kind could be used for the Mirror PA as shown in Figure 27. Keeping in mind that the output combiners (3-dB couplers: Cplr_8, Cplr_9, Cplr_10) may add some loss (1-2 dB), then the total output power will be greater than 40 dBm (10 Watts) which is sufficient to satisfy the required specifications. By doing so the ratio in size between the main PA and the mirror PA will be 4:1 making the overhead in power only 25% extra of the originally consumed power without the linearization.

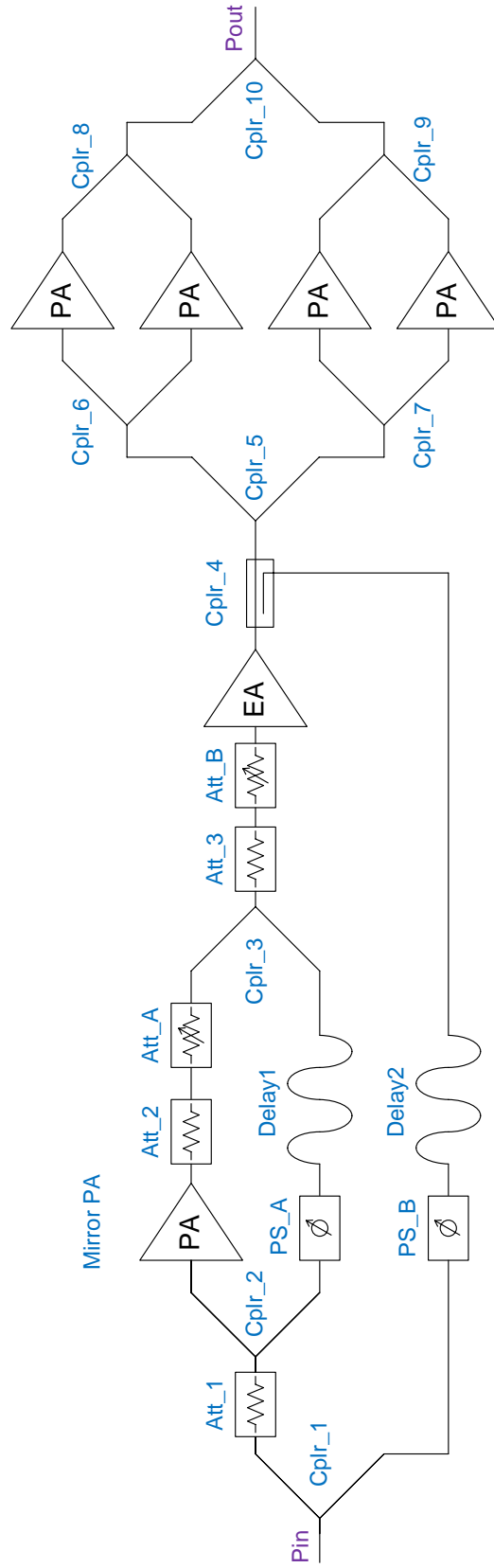

Figure 27: Schematic of the Hybrid module Mirror PD Linearized PA.

- **Error Amplifier (EA)**

The selection of the right EA is very important in the performance of the PD. This is because it has to be very low in power consumption in order not to degrade the efficiency of the whole PA, but at the same time has to have high enough output power capability to avoid extra generated intermodulation terms at its output when it is close to compression. So the power requirement of the EA could be calculated as follows: Based on the AM204437SF-3H Module performance that was measured in the lab experiment in the previous chapter (see Figure 24), the IM3 level at 2 dB BO (34 dBm) is $34-20 = 14$ dBm. The same AM204437SF-3H module MMIC is used in our design. So at the output of any of the PA MMIC's in the above schematic the max IM3 at the 1dB compression will be approximately 10 dB more than 14 dBm: $IM3@P1dB = 10+14 = 24$ dBm. By referencing this value to the input of the MMIC the value will be: $IM3 = 24-Gain = 24-30 = -6$. Then by referencing this value back to the input of *cplr_5* the IM3 level will be: $-6 + 3 + 3 = 0$ dBm. Note that we are using 3 dB couplers for couplers: *cplr_5-7*. Since we want to minimize the output power from the EA, we use a 10 dB coupler (*cplr_4*) with the output of the EA going through the direct port whereas the main signal input going through the 10 dB coupled port. And assuming that the loss of the coupler is approximately zero, the IM3 level at the output of the EA will be 0 dBm. Since no additional nonlinearities are accepted from the EA, we need to have its 1dB compression point to be 20 dB higher than the required output power of 0dBm. So the P1dB compression of the EA should be greater than 20dBm.

Now we need to calculate the required gain for the EA: The generated intermodulation terms at the output of the mirror PA has to arrive with the same magnitude at the output of each of the four PAs of the main PA. Then we have:

$$\begin{aligned}
 & -Att_2 - Att_A - 3dB \text{ (for } cplr_3) - Att_3 - Att_B \\
 & + Gain_{EA} - 3dB \text{ (for } cplr_5) - 3dB \text{ (for } cplr_6) \\
 & + 30dB \text{ (gain of PA)} = 0
 \end{aligned} \tag{1.9}$$

Since we need to cancel the carrier at the output of *Cplr_3*, the total gain of the mirror PA, *Att_2*, *Att_A* has to be equal to the total gain of *PS_A* and the *Delay 1*. Assuming that *PS_A* and *Delay 1* will have zero loss, then:

$$Att_2 + Att_A = Gain_{PA} = 30dB \quad (1.10)$$

Substituting from (1.10) in (1.9) we get:

$$Gain_{EA} = 9dB + Att_3 + Att_B \quad (1.11)$$

The purpose of *Att_3* is to serve as a fixed attenuator for coarse tuning, whereas *Att_B* is a variable attenuator for fine tuning. So assuming the loss of the variable attenuator to be around 2 dB and that of the fixed attenuator to be another 2 dB, then the gain of the EA should be greater than 13 dB.

AMCOM MMIC AM304031WM-BM has an output P1dB of 30 dBm and a gain of 30 dB. So it satisfies the requirements of the EA power and gain. It consumes a DC current of 700 mA from an 8 V supply. This is close to one half the current consumption of the PA unit cells (AM204437WM-BM) of 1.8 A. Although it is a little bit high, the MMIC could be operated at much lower current since the power requirement of the EA (20 dBm) is much lower than the MMIC capability (30 dBm). So the MMIC could actually be operated at half its DC current, i.e. at 350 mA only, in order to enhance the overall efficiency.

▪ Couplers

We need 3 dB couplers for all of the couplers except for *Cplr_4* that need to be a 10 dB coupler. So we choose the right couplers that can work in the WiMax frequency band, surface mountable (SMT) with the smallest possible size, and in the same time satisfy the power requirements especially for the three power combining couplers at the output of the main PA: *Cplr_8-10*.

- **Fixed Attenuators**

The fixed attenuators could be easily implemented using Pi-Attenuators as shown in Figure 28. The three resistors should have values that satisfy the required loss value and in the same time maintain 50 ohms input and output impedances for the good return loss. This could be accomplished if we choose the resistor values from the following equations that could be found in the literatures:

$$R_3 = \frac{25[10^{L/10} - 1]}{\sqrt{10^{L/10}}} \quad \text{ohms}$$

$$R_1 = R_2 = \frac{50[10^{L/10} - 1] - 1/R_3}{10^{L/10} + 1} \quad \text{ohms} \quad (1.12)$$

Where L is the required loss in dB.

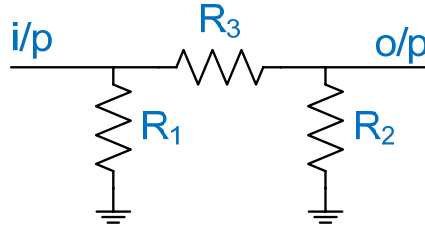

Figure 28: Pi Attenuator.

Note that for *Att_2* a special kind of attenuator that can handle high power (4 Watts) has to be used at the output of the mirror PA.

- **Delay Lines**

We are going to choose the Microstrip transmission lines for the different RF connections since it is very popular and easy to implement on a high frequency PCB. The delay lines could be easily implemented as long transmission lines that can take a snake shape in order to save PCB space. However the problem is that once the PCB is manufactured the delay value could not be modified for coarse tuning. This coarse tuning is important since the simulation of the delay of different components may not be accurate enough to calculate the required values for *Delay 1* and *Delay 2* before building the circuit. So in

order to solve this problems, the delay lines could be built from different sections as shown in Figure 29, and then we can either connect these sections or disconnect them by using zero ohm resistors for tuning.

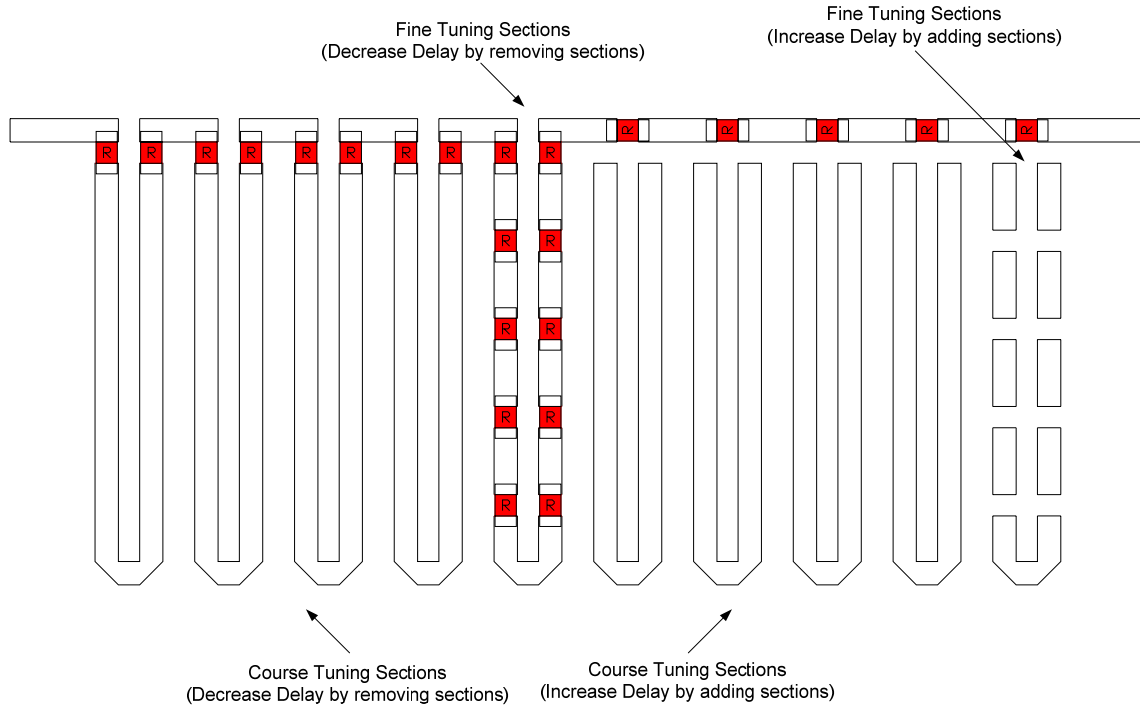

Figure 29: Delay Tuning on PCB.

▪ Vector Modulators

The vector modulators are very important because they are used to fine tune the magnitude and phase in order to achieve:

1. Carrier cancellation at the output of *Cplr_3*, where *Vector Modulator 1* is used and consists of *Att_A* and *PS_A*.
2. The correct phase and magnitude feeding of the intermodulation terms to the input of the main PA, where *Vector Modulator 2* is used and consists of *Att_B* and *PS_B*.

The simplest way for tuning is to have an analog variable attenuator and phase shifter where the magnitude and phase could be controlled based on an analog DC input voltage. It was hard to find analog variable attenuator or phase shifter in the market that works in

the desired frequency band while being surface mountable. So the only solution was to build a variable attenuator and a variable phase shifter. This could be implemented in different ways usually by using PIN diodes and varactors. The PIN diodes change their RF resistance with DC bias so they could be used to build variable attenuators, whereas the varactors change their capacitance with DC bias so they could be used as variable phase shifters. The main challenge with any of the implementation techniques available in the literature is the maximum frequency of operation. There are no accurate high frequency nonlinear models available for any of the PIN diodes or varactors available in the market. So, an implementation technique that has the minimum count of pin diodes or varactors will have higher chances to work at the frequency of operation (3.5 GHz). Based on that the best implementation technique would be to use the Reflective Topology [13]. In this topology a 3dB 90° Hybrid coupler is used along with two bias controlled PIN diodes for variable attenuators or varactors for phase shifter. The main theory of operation of Reflective Topology is described in Figure 30. When an RF signal is incident on port 1 it divides and appears at the two output ports, ports 3 & 4, with equal magnitude but 90° out of phase. If ports 3 & 4 are not perfectly matched to 50 Ω there will be some signal that reflect back to the coupler. If the magnitude and phase of these reflections are equal, there will be two signals that have equal magnitude and 90° out of phase, i.e. the reflected signals, being applied to ports 3 & 4 as inputs. These reflected signals will combine at the isolated port and will cancel at the input port. So, terminations with the same mismatch placed at the outputs of the 3dB coupler will not reflect back to the input port and therefore will not affect input return loss.

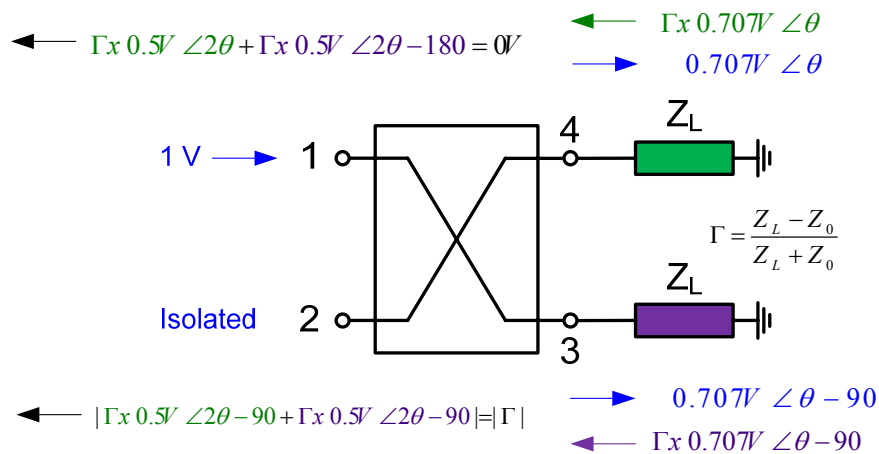

Figure 30: Reflective Topology of a 3dB 90° Hybrid coupler.

The voltage variable attenuator is illustrated in Figure 31 where two identical PIN diodes are used as the load impedances for the hybrid coupler. When the bias of the diodes is adjusted so that their RF resistance is 50Ω , the reflection coefficient Γ will be zero and no signal output will be received at port 2 (Maximum attenuation), whereas when the RF resistance of the diodes are adjusted to a very small or a very large value, Γ will approach its maximum value of 1 resulting in minimum attenuation. So in any of the RF resistance ranges ($0-50\ \Omega$) or ($50 - \infty\ \Omega$) the attenuation will change from minimum to maximum or from maximum to minimum while the phase will ideally remain constant.

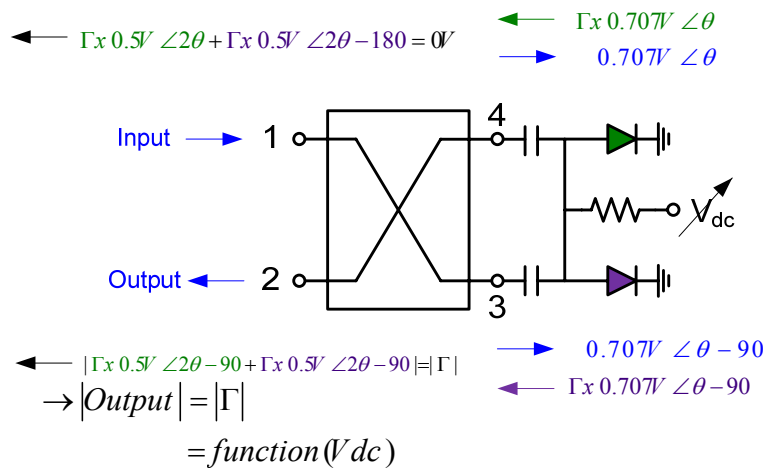

Figure 31: Variable attenuator by using the Reflective Topology of a 3dB 90° hybrid coupler.

The same idea used in the variable attenuator could be used to build a variable phase shifter by using two identical varactor diodes as the load impedances as shown in Figure 32. Ideally the varactors will act as variable capacitors with the voltage bias where all the signal will be reflected so that the magnitude of Γ will be one, whereas its phase will change depending on the value of the capacitance. The beauty of this topology is that the delay and magnitude from port 1 to 2 will remain constant while the phase is changing. It is very important in building a vector modulator to have two independent controls: one for phase and one for magnitude, where the phase shift of the variable attenuator will remain constant when it is tuned, whereas the magnitude of the phase shifter will remain constant when it is tuned. If these two conditions are not satisfied, tuning will be very difficult and a lot of successive iterations have to be done to achieve the required performance.

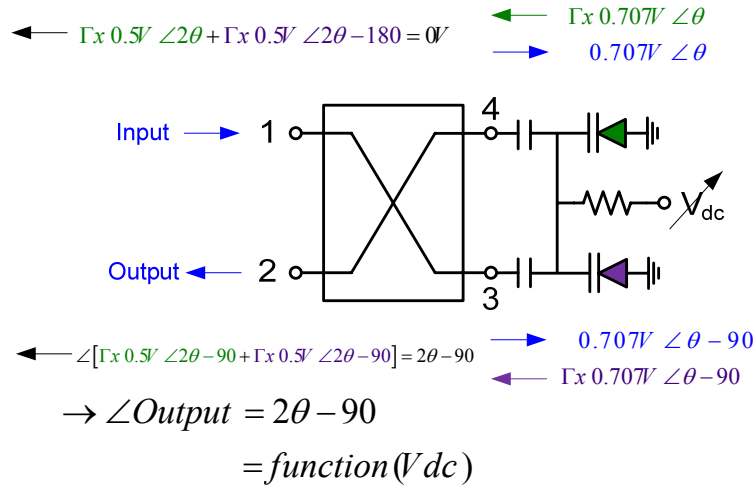

Figure 32: Variable phase shifter by using the Reflective Topology of a 3dB 90° hybrid coupler.

So now since we have selected the reflective topology, the same 3dB couplers used in different parts of the circuit (couplers: *Cplr_1-3* and *Cplr_5-10*) could be used to build the variable attenuators and phase Shifters.

3.3 Layout

The final Layout drawing of the PCB inside the housing (the Aluminum enclosure with the two RF input and output and the DC connectors) is shown in Figure 33. The dimensions of the housing are: W 2.9 , L 6.1, H 0.6 inches. A photo of the built module is shown in Figure 34. The layout was done in a way that makes it as compact as possible, but in the same time sufficient distances between different components were left to avoid coupling.

The module has to be supplied with a regulated 8V DC supply through the DC connector. A voltage inverter circuit was included to provide negative supply that is necessary for the gate supplies of the FET's in different MMIC's inside the module (the EA and the 5 MMIC's of the mirror and the main PAs). RF bypass capacitors were added in lots of places along the positive and negative supply lines to avoid coupling. Coupling is very undesirable because it could cause unpredictable magnitude and phase shifts, or a positive feedback that can lead to oscillations.

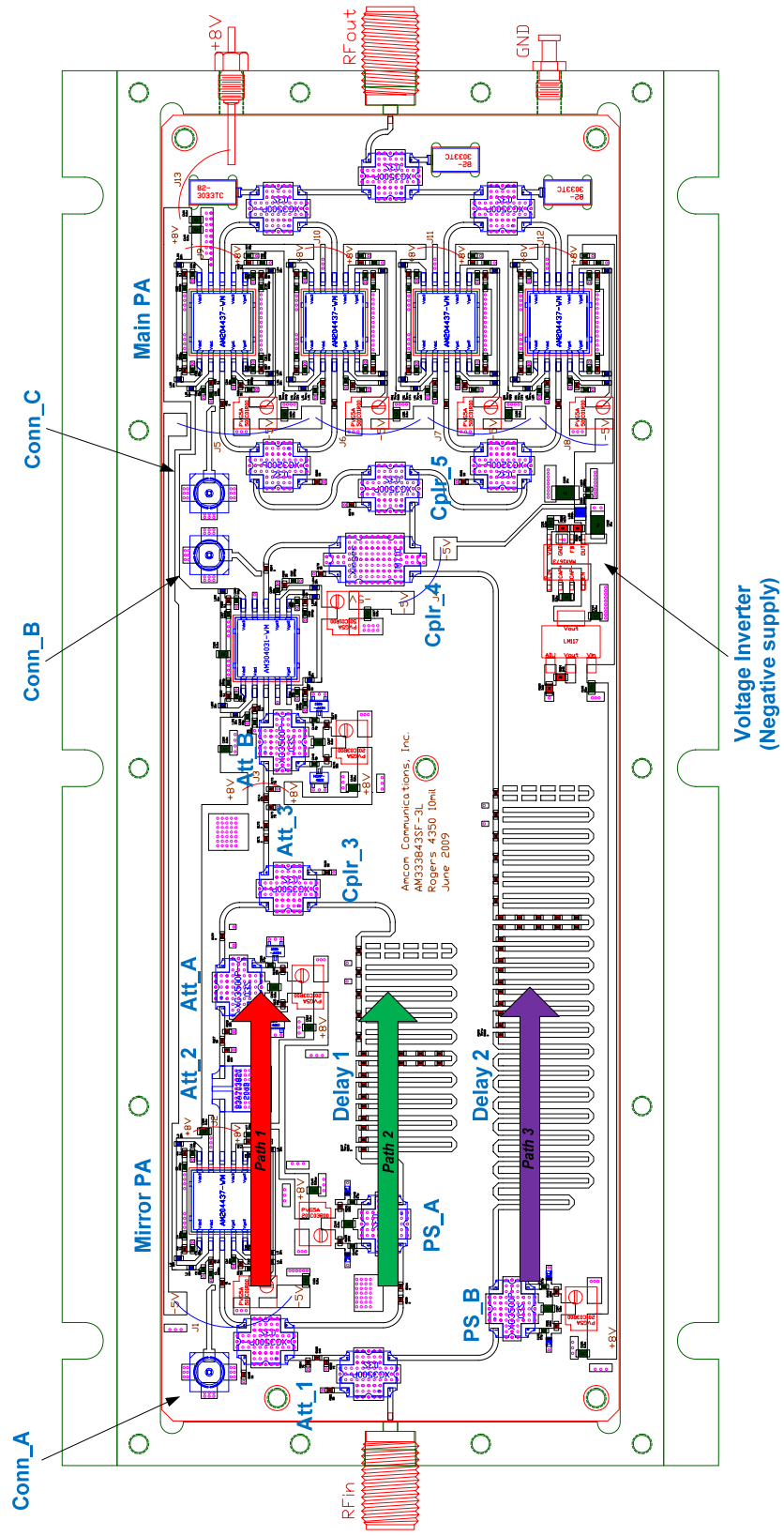

Figure 33: Layout of the Mirror PD Linearized PA.



Figure 34: The built Module for the Mirror PD Linearized PA. Photo by author, 2009.

The same 8V supply was used to bias the variable attenuators and phase shifters with a resistor potentiometer that allows the control of the magnitude or the phase by using a screw driver. Connectors *Conn_A*, *Conn_B*, and *Conn_C* are RF SMT connectors that are added to help in tuning as will be described in the following section.

3.4 Tuning

Earlier in Chapter 2 we discussed that the main advantage of the Mirror PD linearization technique, as compared to the other predistortion techniques, is that no measurement of the nonlinear AM-AM and AM-PM of the PA and the PD circuits is necessary. Instead we follow a straight forward procedure to tune the circuit to the best linearization performance. This is done by the use of variable attenuators and phase shifters, variable delay lines *Delay 1* and *Delay 2*, and SMT connectors *Conn_A*, *Conn_B* and *Conn_C*.

So first of all we want to start with a close estimate of the values for the fixed attenuators and the delay lines. This is done by running linear S-parameter simulation of the module before we build it. In this simulation S-parameter files for the different components were used to simulate the magnitude, phase, and delay of different paths in order to determine the values of different components (delays and attenuators).

Then after the module was built, a vector network analyzer (VNA) was used, before doing any nonlinear measurement, to tune the performance by measuring the S-parameters of different sections. Note that each path from paths 1, 2, & 3 shown in Figure 33 could be disconnected or connected by using a zero ohm resistor in series in each path. To disconnect a path we remove that resistor and connect two 50 ohms resistors at each end to avoid reflections from either ends. The following tuning steps were followed:

1. While disconnecting paths 2 & 3, measure and record S21 for path 1 from the input to *Conn_B*.

2. While disconnecting paths 1 & 3, measure and record S21 for path 2 from the input to *Conn_B*.
3. Compensate for the difference in delay by tuning *Delay 1* making sure that the phase difference between paths 1 & 2 should be 180° in order to cancel the carrier, Also compensate for the magnitude difference by changing *Att_2*.
4. Now while path 3 is disconnected, measure S21 again between the input and *Conn_B* to make sure that the compensation of the carrier is now working, where the magnitude of S21 should now be smaller than any of paths 1 or 2 by at least 30 dB over the band of operation.
5. Measure S21 between the input and *Conn_A*. Then do the same thing between the input and *Conn_C* through path 3 (paths 1 & 2 disconnected) and make sure that both magnitudes are equal to ensure that both the mirror PA and every unit of the main PA are operating at the same input power level. Change the attenuation of *Att_1* if necessary to compensate for any difference in magnitude.
6. The last thing we need to do is to make sure that the intermodulation terms arrive at the correct magnitude, phase and delay at the input of the main PA. This is done by repeating steps 1-4 but by doing the measurement between the input and *Conn_C* and for paths 1 and 3 while path 2 is disconnected. Any necessary tuning could be done by changing *Att_3* and *Delay 2*.

Note that in all the previous steps we try to keep any fine tuning elements in the middle of their tuning ranges for the final tweaking of the nonlinearities during the nonlinear measurements.

3.5 Summary

In this chapter we have shown how to select the different components based on the required specifications. Also the final layout of the PCB was shown and the different issues and details were discussed. The main challenge in that layout was how to make the size as compact as possible but in the same time avoid any coupling or feedback that could have caused oscillations. Also a step by step tuning procedure of different attenuators and delay lines was presented, making the design of the Mirror PD linearizer very systematic and straight forward as compared to other PD techniques that requires a full nonlinear measurements of the main PA and the PD circuits. In the next chapter the intermodulation and power measurements setup will be presented along with the final results and comments.

Chapter 4

Measurement Results

After building the amplifier, and using the step by step procedure outlined in the previous chapter to do the initial linear tuning, now it is time for the nonlinear measurements of power and intermodulation products (IMD3 and IMD5) and for fine tuning to achieve the best performance.

4.1 Lab Setup

Figure 35 shows the lab setup used for measurement. The measurement is done at the 3.5 GHz WiMax band. Two RF generators are used for the two tone intermodulation measurement where they are separated by a relatively small frequency (Δf). Two driver amplifiers are used to increase the generators power level to the required level to drive the PA. A computer program is used to sweep the input power and read and communicate with the different equipments for automatic measurements of Pin-Pout, Efficiency, Gain, and intermodulation levels for the IMD3 and IMD5 measurements. Also the power generators and the spectrum analyzer are tied together with a reference line for synchronization. Attenuators are used before the power meters for protection. The PA could be tested with or without linearization. In order to turn off the linearization the EA is turned off by pinching off its pHEMT FET's. This is done by applying high negative voltage by changing a potentiometer at their gates. Figure 36 shows a photo of the lab setup. Heat sinks and fans are used with the Driver PAs and with the PA under test to protect the devices from any damage that could result from excessive heat generation. A temperature sensor is tied to the PA to monitor its temperature.

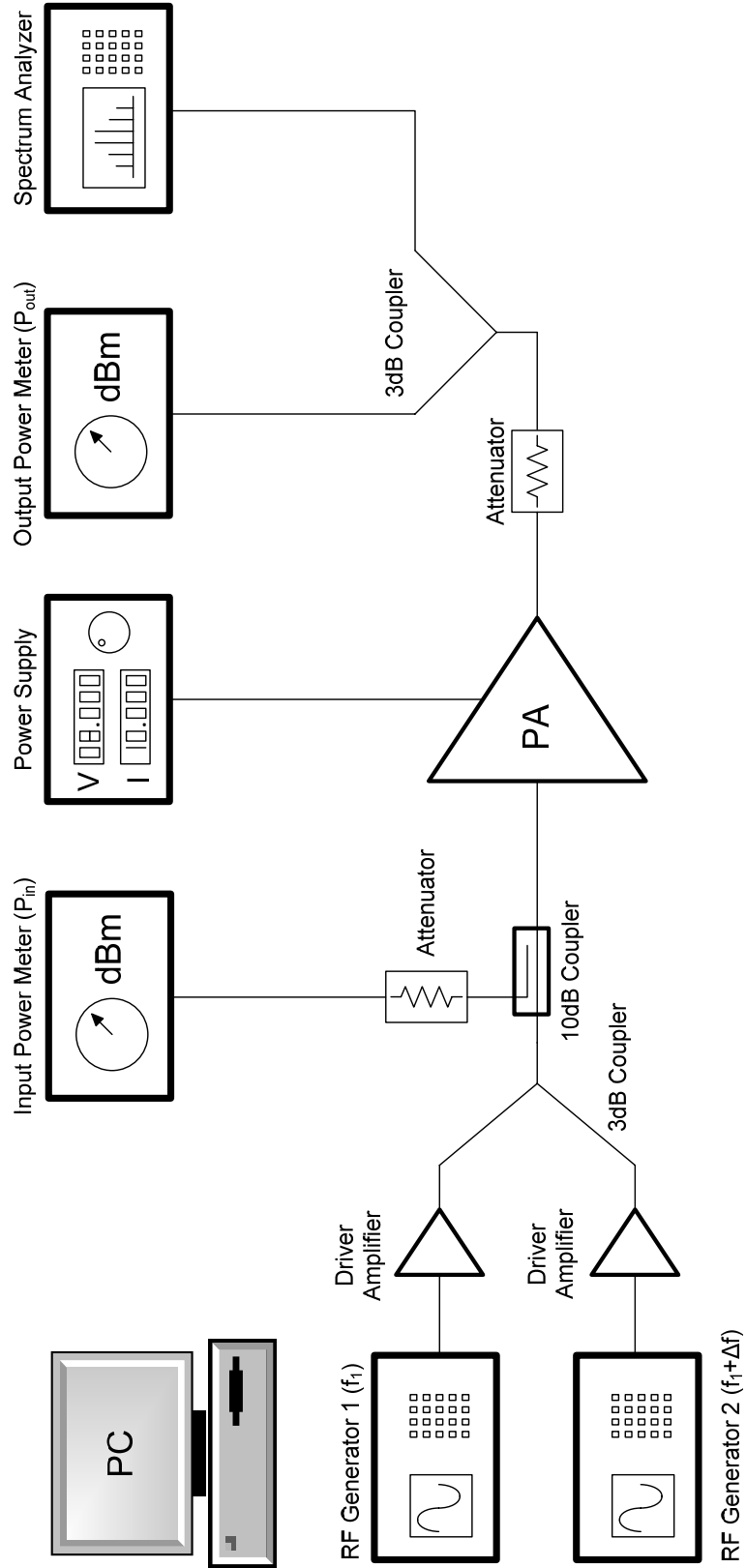

Figure 35: Lab Measurement Setup.

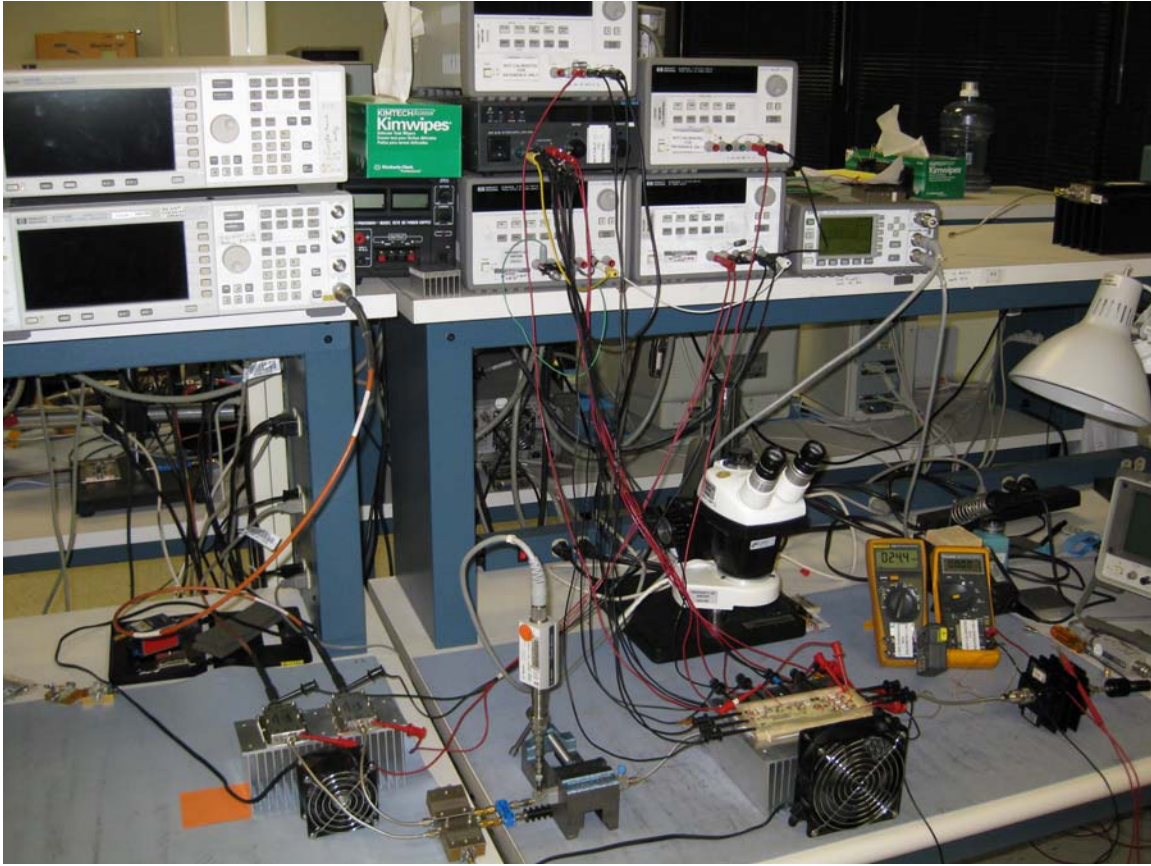

Figure 36: Nonlinear measurement lab setup. Photo by author, 2009.

4.2 Results

First of all, while turning off the linearization, we measured P1dB of 41.5 dBm and a gain is 14 dB. The gain is lower than the original 30 dB gain of the MMIC used because of feeding the main signal from a 10 dB coupler through path 3 as described in the previous chapter (see Figure 33), and because of the 3 dB loss in *Cplr_1* and the loss in *PS_B* and in the delay line *Delay_2*. So now for the fine tuning of the PA, we set the power generators to give a total output power of 34 dBm (7.5 dB BO from the P1dB), we turn ON the linearization, and we fine tune the variable attenuators and phase shifters to achieve the best performance (lowest power of the IM3 and IM5 monitored on the spectrum analyzer). The resulting IMD3 and IMD5 vs. Pout are shown in Figure 37 and Figure 38 respectively. So a 23 dB improvement in IMD3 is achieved at a 7.5 dB BO (34 dBm), and a 5 dB improvement in IMD5 is achieved at 8.5 dB BO.

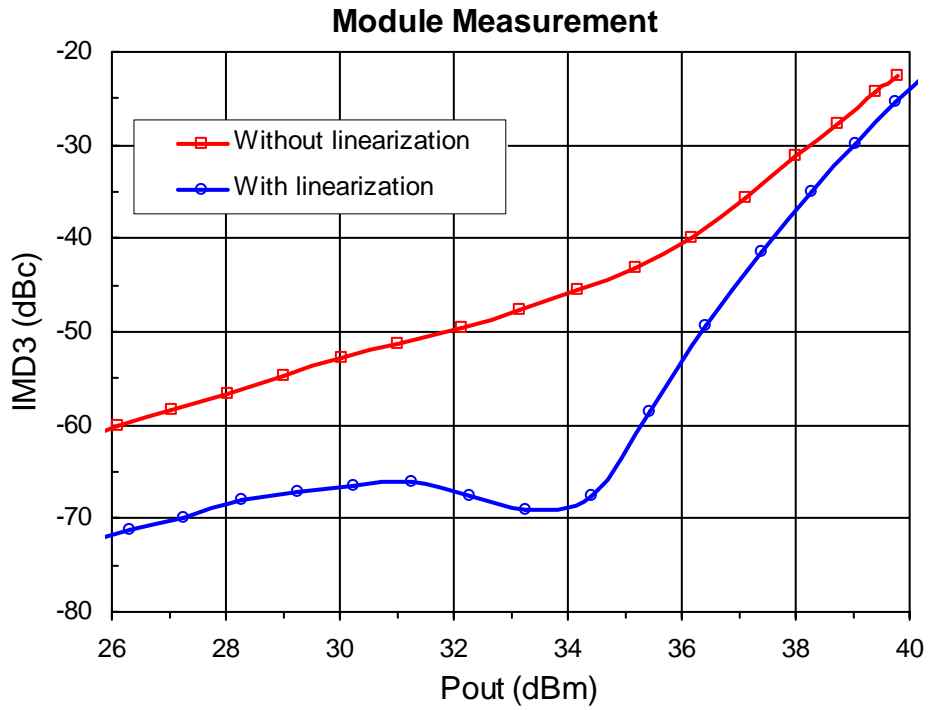

Figure 37: Hybrid Module measured IMD3 with and without linearization.

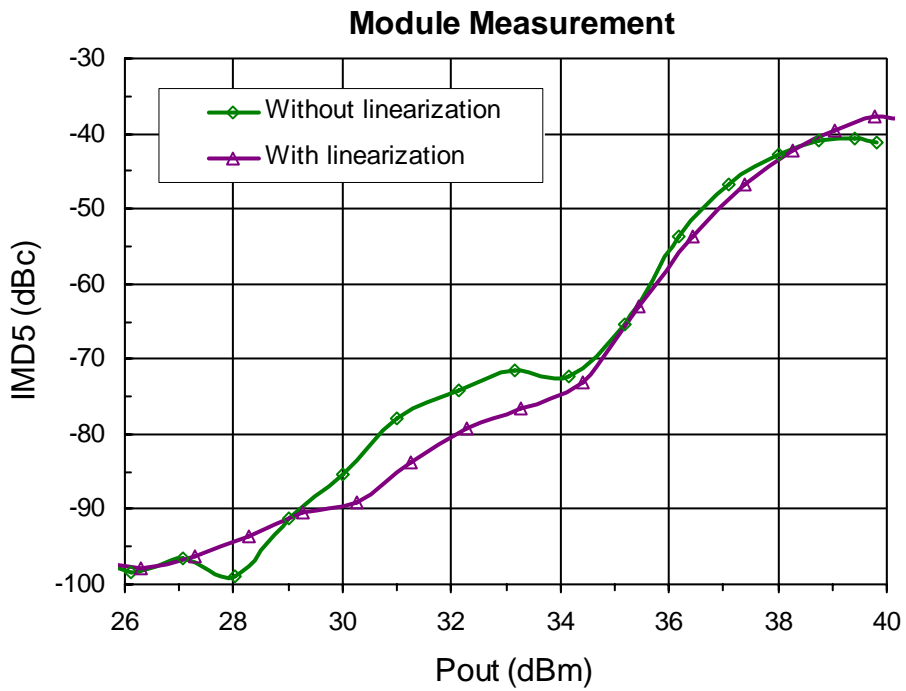

Figure 38: Hybrid Module measured IMD5 with and without linearization.

Again, we notice, as discussed and explained in the simulation results, that the improvement in IMD3 and IMD5 degrades at higher power levels. However the linearization is still working even close to the PA compression where an improvement of 5 dB is achieved at 3.5 dB BO. Also because of the linearization the measured P1dB of the PA has increased by about 0.8 dB from 41.5 dBm to 42.3 dB. In addition, the performance degrades also at lower power levels (only 10 dB improvement in IMD3 is achieved at a BO value of 13.5 dB), a possible reason for that could be the process mismatch between the Mirror and the Main PA MMIC's. However at that low power range the IM3 and IM5 levels are very low and the PA is already very linear.

The degradation in IMD5 below 29dBm of output power could be because the IM5 level measured has fallen below the sensitivity of the spectrum analyzer so that its reading is not accurate at that very low level. Moreover for higher power levels we can notice that there is no further improvement in the IMD5 but it does not degrade at least where the IM5 level remains lower than IM3 in that range. As long as the IM3 level is higher than the IM5 level, the nonlinearities of the PA could be specified by its third order nonlinear performance, or the IP3, however if the IM3 level becomes lower than the IM5 that will not be valid any more, and the IP5 will become of more importance.

Also the Efficiency of the PA with and without linearization is plotted against the IMD3 in Figure 39. In this plot we can notice an increase in the Efficiency for the same IMD3 of -60 dBc from 1% to 4% which is equivalent to increasing the power capability of the PA four times. However for IMD3 levels higher than -38 dBc we can see degradation in Efficiency. This is because the use of additional power consumption in the mirror PA MMIC does not justify for the improvement in the IMD3 at that range.

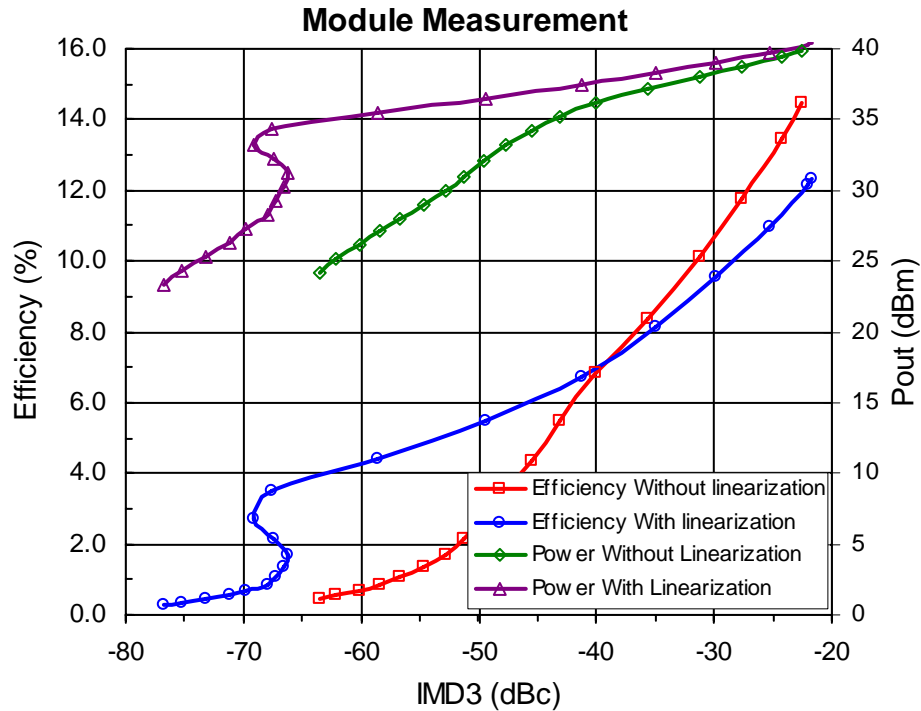

Figure 39: Hybrid Module measured Efficiency & Pout vs. IMD3 with and without linearization.

In order to check the broad band performance of the PA we plot IMD3 at different frequency spacing between the two testing frequency tones as shown in Figure 40. We can see from this plot that the performance is approximately the same for the frequency spacing of 1MHz, 10 MHz, and 20 MHz (Note that the previous plots were done at a frequency spacing of 10 MHz).

Moreover while fixing the spacing between the first and second frequency tones, we vary the frequency of the first frequency tone by ± 100 MHz from its main center frequency of 3.5 GHz. The resulting IMD3 is plotted vs. the output power in Figure 41. The average degradation in the IMD3 improvement is about 10 dB at 3.4 GHz and 3.6 GHz. However we still get some improvement (around 10 dB) at those frequencies which shows that the linearization is still working. A better performance could be achieved if we can get rid of the zero ohm resistors used in *Delay 1* and *Delay 2* which make the gain of path 2 and path 3 non flat with frequency.

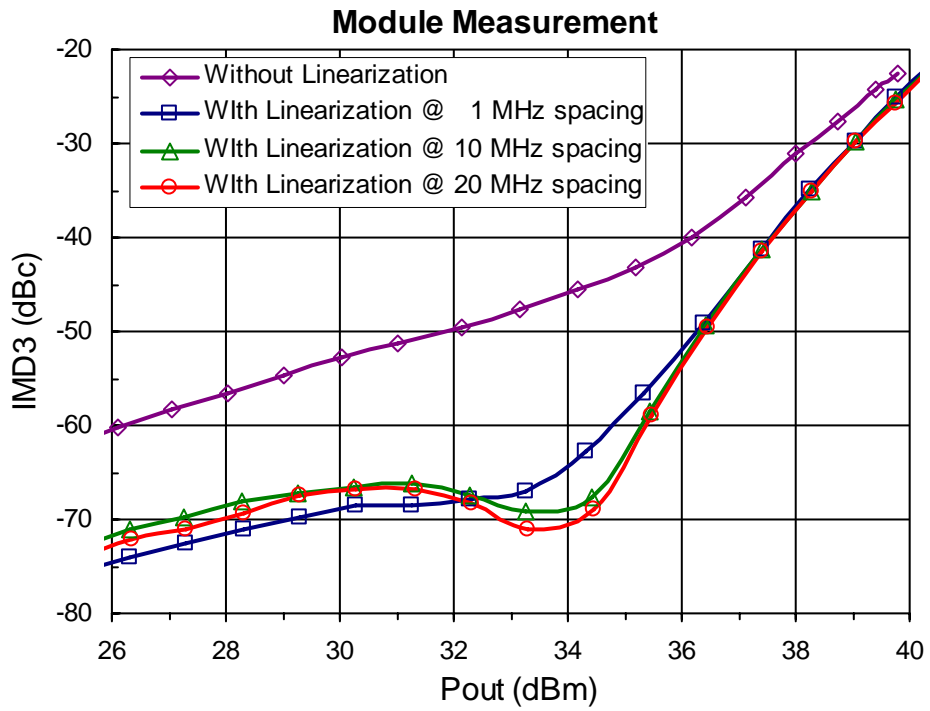

Figure 40: Hybrid Module measured IMD3 at different two tone frequency spacing.

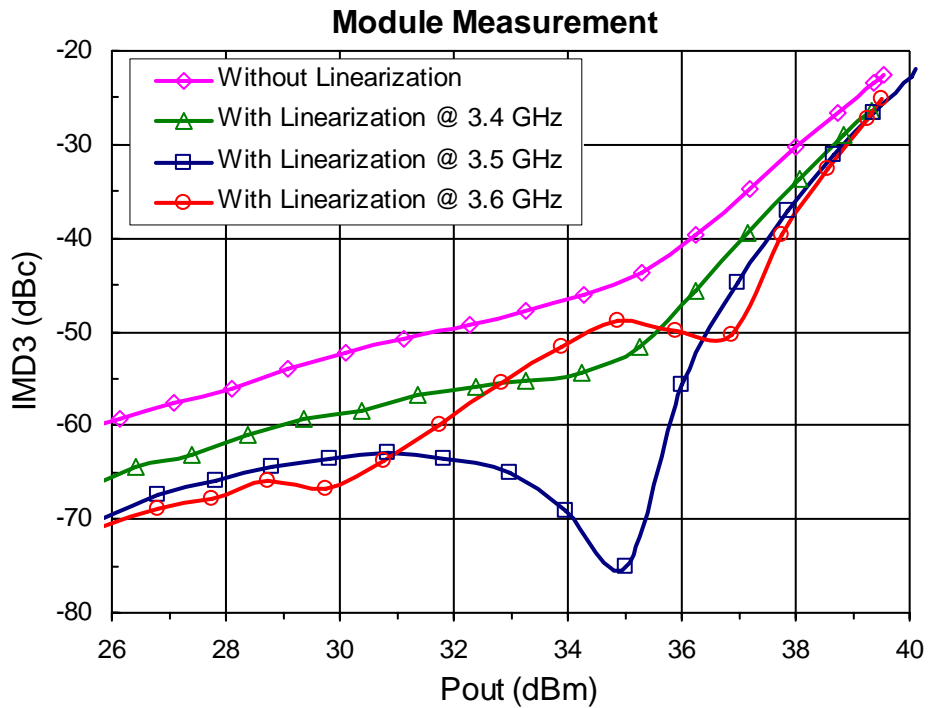

Figure 41: Hybrid Module measured IMD3 at different frequencies.

Also we want to examine is the linearization affected with the variation of temperature. So while the fan applied to the heat sink under the PA is on, we fine tune the PA for the minimum IMD3 level. Then after recording IMD3 vs. Pout, we turn off the fan and let the module run for a while until its temperature is 10° C higher where we repeat the measurement. The resulting plot is shown in Figure 42. We notice an average degradation of about 10 dB. The reason for that degradation could be explained as follow: Although the mirror PA is tracking the main PA with temperature since they are mounted on the same heat sink, the other components especially the EA are not. This results in gain and phase mismatches between paths 1 & 2 (see Figure 33) which leads to carrier leakage, and also to gain and phase mismatches between paths 1 and 3 resulting in non optimum nonlinearities cancellation at the output of the PA.

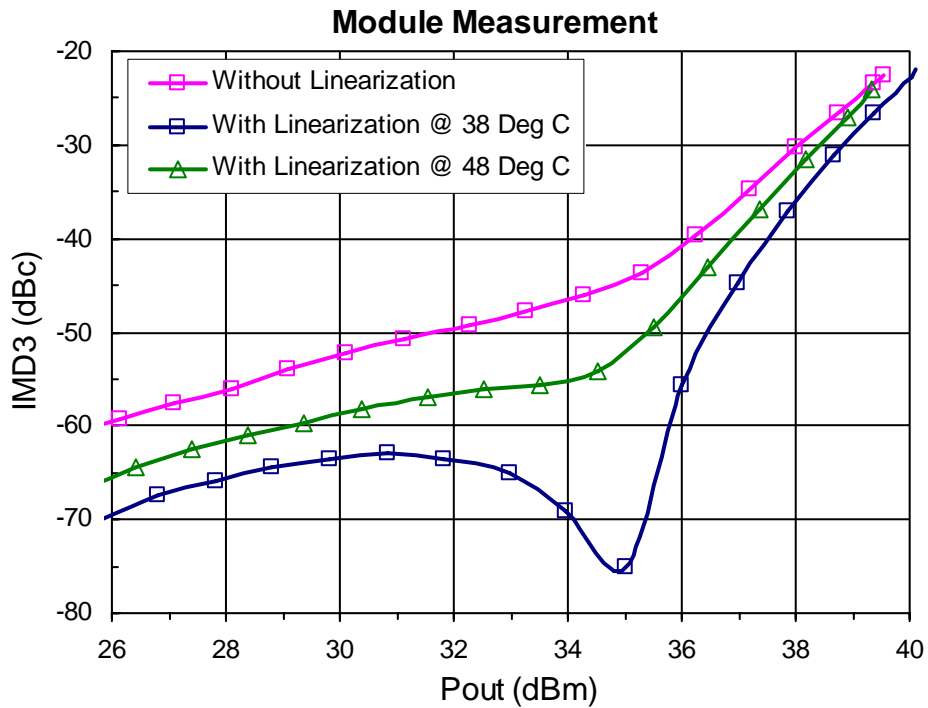

Figure 42: Hybrid Module measured IMD3 at different temperatures.

We tuned the PA for the best linearity performance at a BO value of 7.5 dB. Now we tune it at different BO values and see whether we can achieve better performance especially at higher power levels where linearization is more important. The result is plotted in Figure 43 where the PA is tuned at 3.5 dB and at 5.5 dB in addition to the original value of 7.5 dB. Although the 3.5 and 7.5 dB tuning achieved better linearization at higher power levels, their performance is very narrow with power, where their linearity performance deteriorate very quickly outside that range. So based on this plot, the 7.5 dB tuning is the best where it gives very broad performance with power. However if we design an additional control circuit that can change the tuning element automatically based on sensing the power level, much better linearity performance could be achieved for a broader range of power levels. But of coarse the price paid for that will be additional cost and complexity.

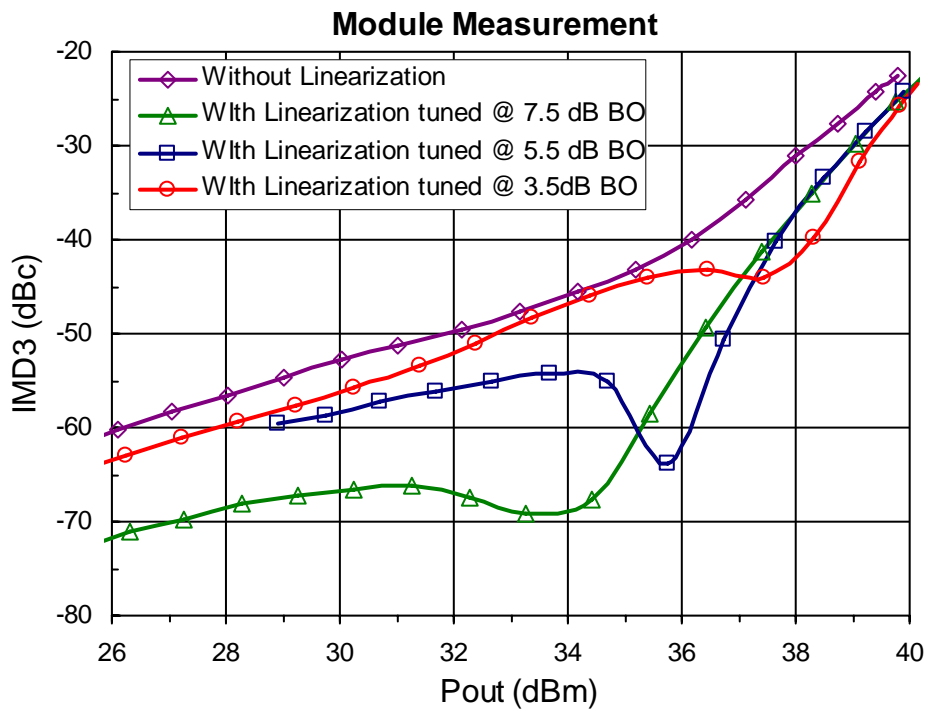

Figure 43: Hybrid Module measured IMD3 vs. Pout when tuned at different Back Off (BO) values.

Chapter 5

Conclusion & Future Work

The main focus of this thesis was how to address the problem of increasing data rates in wireless communications systems in terms of the linearity requirements of Power Amplifiers. PAs are very power hungry devices and one of the most challenging components in any wireless system. In order to increase the efficiency of PA a linearization technique that is more sophisticated than Backing off has to be applied. So in the first chapter we presented different linearization techniques that could be used to achieve that. Every one of them has its own advantages and disadvantages. However we focused on Predistortion because it has moderate linearization, cost and complexity. We presented different Predistortion techniques where again each of them has its own pros and cons.

In the second chapter we proposed a new linearization technique that we called “Mirror Predistortion Linearization” technique. In this technique a predistorter that mirrors the performance of the main PA is used. So it is a predistortion technique but in the same time it looks very similar to Feedforward linearization with the difference that the nonlinearities is generated by using a mirror PA instead of using the main PA itself, and those nonlinearities are being fed to the input instead of the output of the PA; which reduces the power requirements of the Error Amplifier. In order to verify the concept both simulations and a quick lab setup were used.

In the third chapter we assumed certain specifications for the PA and based on those specification we selected different SMT components that could fit inside a relatively small and compact Hybrid Module PA that utilizes the proposed technique making it easy to use and more practical to be integrated in a wireless communications system. Then in

Chapter 4 we presented the results of the measurement of that Hybrid Module and compared it to both the simulation and the quick lab setup.

5.1 Conclusion

In this thesis work we presented a new linearization technique: “Mirror Predistortion Linearization”. We proved that the concept works by simulation, quick lab setup and by building and measuring a Hybrid Module version that makes the new technique easy to integrate within any wireless communication system.

The results of the Hybrid Module measurement showed an IMD3 improvement of 23 dB at a BO value of 7.5 dB and 5 dB at a BO value of 3.5 dB. The improvement that was achieved even at high output power is a direct result of the tracking between the mirror and the main PAs which also results in an increase in the P1dB of the implemented module by 0.7 dB. As a result of the linearization the efficiency of the PA increased by four times at IMD3 level of -60 dBc. The enhancement in the efficiency was achieved up to IMD3 level of -38 dBc. At IMD3 levels higher than -38 dBc, the small improvement in the IMD3 did not justify for consuming power in an additional MMIC for the mirror PA. The IMD5 improved also by 5 dB at BO value of 8.5 dB but no improvement was achieved at higher power levels.

The module performance was not affected by a two tone frequency spacing of 20 MHz which is enough for a WiMax channel. However for higher testing frequencies (± 100 MHz) the improvement in the IMD3 degraded by about 10 dB. The performance of the module also degraded about 10 dB with a temperature change of 10° C which shows that it is sensitive for temperature variations.

5.2 Future Work

Although the overall results of the implemented module showed good performance, it did not track well with temperature variations. The reason for that is that the Error Amplifier adds gain variations that result in non-optimum performance for the predistorter. A suggested solution for correcting the temperature tracking is to add a temperature sensor that controls the variable attenuator of *Vector Modulator 2* as shown in Figure 44

Moreover the achieved bandwidth was lower than expected. This is because the zero-ohm resistors used to connect the variable delay lines, as shown Figure 29, had loss with a frequency slope that resulted in non-flat gain and phase of paths *EG* and *CJ* (see Figure 44). So after knowing the right delay values, those resistors have to be removed and replaced with continuous delay lines that have fixed lengths.

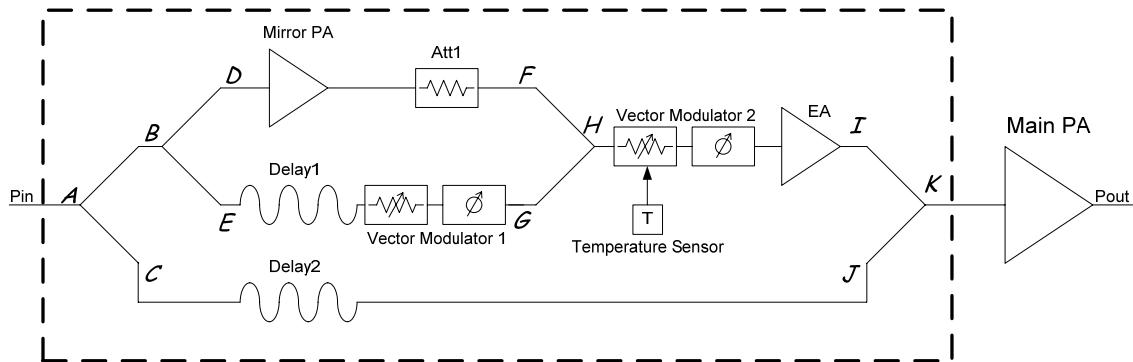

Figure 44: Suggested Modification to the Mirror PD Linearization.

References

- [1] J. Rogers and C. Plett, *Radio frequency integrated circuit design*. Chapter 2. Boston: Artech House, 2003.
- [2] S. C. Cripps, *RF power amplifiers for wireless communications*. Boston: Artech House, 1999.
- [3] S. C. Cripps, *Advanced techniques in RF power amplifier design*. Boston: Artech House, 2002.
- [4] K. Yamauchi, K. Mori, M. Nakayama, Y. Itoh, Y. Mitsui, and O. Ishida, "A novel series diode linearizer for mobile radio power amplifiers," *IEEE MTT-S Int. Microwave Symp. Dig.*, Vol. 3, pp. 831-834, June 1996.
- [5] T. Nojima and T. Konno, "Cuber Predistortion Linearizer for Relay Equipment in 800 MHz Band Land Mobile Telephone System," *IEEE Transactions on Vehicular Technology*, VT-34, n 4, pp. 169-177, November 1985.
- [6] K. Morris and P. Kenington, "Power amplifier linearisation using predistortion techniques," *IEE Colloquium on RF and Microwave Components for Communication Systems*, Bradford UK, 1997.
- [7] J. Yi, Y. Yang, M. Park, W. Kang, and B. Kim, "Analog predistortion linearizer for high-power RF amplifiers," *IEEE Trans. Microwave Theory & Tech.*, Vol. 48, no. 12, pp. 2709-2713, 2000.
- [8] Y. S. Lee, K. I. Jeon, and Y. H. Jeong "Linearity Improvement of RF Power Amplifiers Using a Simple High-Order Predistorter for WCDMA Applications". *Proceeding of 2006 Asia-Pacific Microwave Conference*, vol. 2, pp. 887-890, 2006

- [9] S. Y. Lee, Y. S. Lee, S. H. Hong, H. S. Choi, and Y. H. Jeong "Independently controllable 3rd- and 5th-order analog predistortion linearizer for RF power amplifier in GSM," *Proceedings of 2004 IEEE Asia-Pacific Conference on Advanced System Integrated Circuits*, pp. 146-149, 2004 .
- [10] Y. S. Lee, S. Y. Lee, K. I. Jeon, and Y. H. Jeong "Highly linear predistortion power amplifiers with phase-controlled error generator," *IEEE Microwave & Wireless Components Letters*, vol. 16, no. 12, pp. 690-692, December 2006.
- [11] S. Y. Lee, Y. S. Lee, and Y. H. Jeong, "A novel phase measurement Technique for IM3 Components in RF Power Amplifiers," *IEEE Trans. Microwave Theory & Tech*, vol. 54, no. 1, pp. 451–457, January 2006.
- [12] J. Dunsmore, and D. Goldberg, "Novel Two-Tone Intermodulation Phase Measurement for Evaluating Amplifier Memory Effects," 33rd *European Microwave Conference*, pp. 235-238, October 2003.
- [13] M. Mtimat and A.B. Kouki, "Design and characterization of variable attenuators and phase shifters with linearized bias control voltages," *IEEE Canadian Conference on Electrical & Computer Engineering*, pp. 1085-1088, 2004.