

CHAPTER 2

**GENERAL STUDY OF INTEGRATED SINGLE-STAGE POWER FACTOR
CORRECTION CONVERTERS**

2.1 Introduction

Conventional diode rectifiers have rich input harmonic current and cannot meet the IEC PFC regulation, therefore the power factor correction techniques have been developed to shape the input current and improve the input power factor. In the applications requiring a good input power factor and a high quality tightly regulated dc output voltage, the two-stage approach is widely used in industry. Figure 2.1(a) shows the block structure of the two-stage PFC converter. There is a PFC front-end rectifier and a tightly regulated DC/DC output converter. However, the two-stage approach requires an additional PFC component and increases the cost. This is very undesirable in low power consumer electronic products. In this case, several single-stage PFC approaches have been proposed recently.

Figure 2.1 (b) shows the block structure of the single-stage PFC converters. Normally, the integrated S^2 -PFC converter combines the current-shaping PFC switch and the DC/DC converter switch into one switch to simplify the circuit topology and reduce the total cost. The combined single-stage still has input inductor, the main switch, the bulk capacitor and the isolation transformer. The PFC function is achieved automatically based on the circuit operation instead of the additional PFC control.

So far, there are several interesting integrated single-stage PFC techniques. It is very necessary to find out the generalized structure and the basic PFC condition of these single-stage

PFC converters. In this chapter, the general structures of single-stage PFC converter are derived first. Then, based on the general structure, the necessary condition of a PFC converter is derived and verified by the present single-stage PFC circuits.

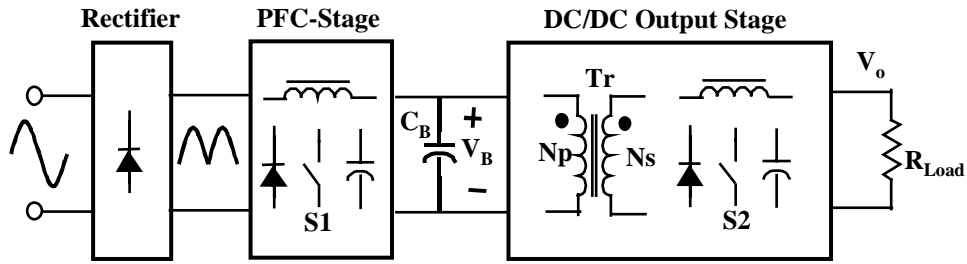

(a)

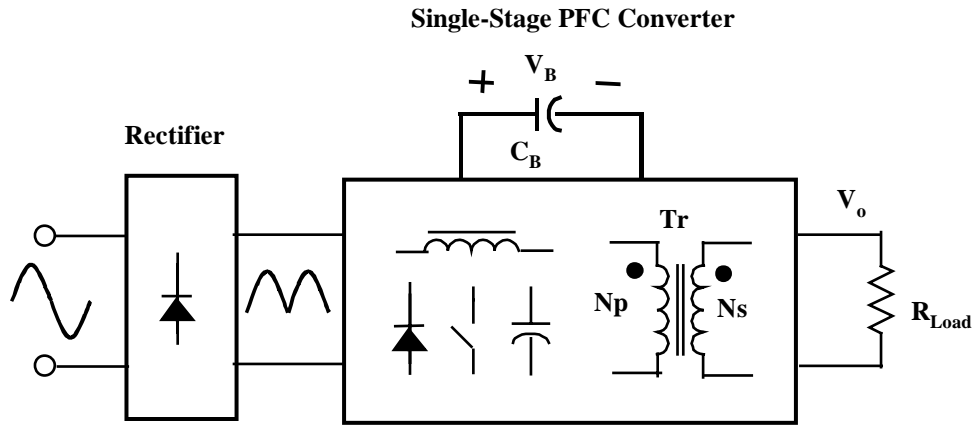

(b)

Fig. 2.1. Block structure of active PFC converters

(a) Two-stage approach

(b) single-stage approach

2.2 General structure of integrated single-stage PFC converter

In order to further understand the general principle of S^2 -PFC converters, it is necessary to first generate the basic structure of single-stage PFC converters. Also, the general structure will help to develop new single-stage PFC topologies.

From topology point of view, most of the integrated PWM single-stage PFC converter can be divided into two groups: the two-terminal S^2 -PFC converter and the three-terminal S^2 -PFC converters. As shown later, the difference between these two groups is the different topology structures of the PFC-cell.

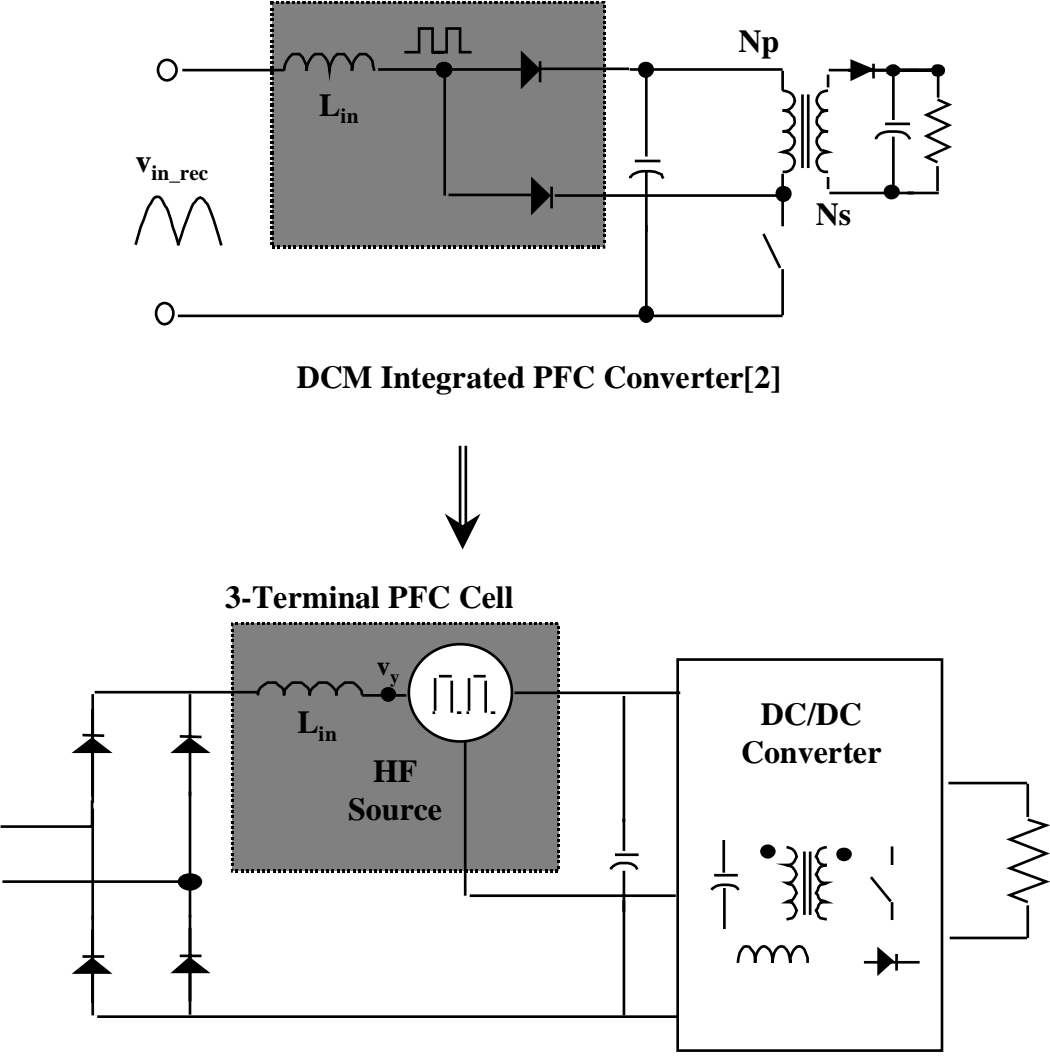

Fig. 2.2 General structure of three-terminal single-stage PFC converters

Figure 2.2 shows how to derive the general structure of the three-terminal S^2 -PFC

converter from the basic DCM integrated PFC converter presented in [B1, B4]. The PFC function is achieved by the three-terminal PFC cell in the shadowed block and the output stage can be any DC/DC converter with PWM constant duty-cycle control. The three-terminal PFC cell normally has a PFC inductor and a high frequency source. The high frequency source can be a combination of many passive components, such as inductor, high-frequency capacitor, high-frequency diode and coupled transformer windings. In this source, there is a switching frequency signal abstracted from the DC/DC output stage converter. The function of the high frequency source will be discussed in section 2.3.

Figure 2.3 shows some example circuits of three-terminal PFC converters. Figure 2.3(a) is the DCM S^2 -PFC converter with a feedback winding to limit the bus voltage

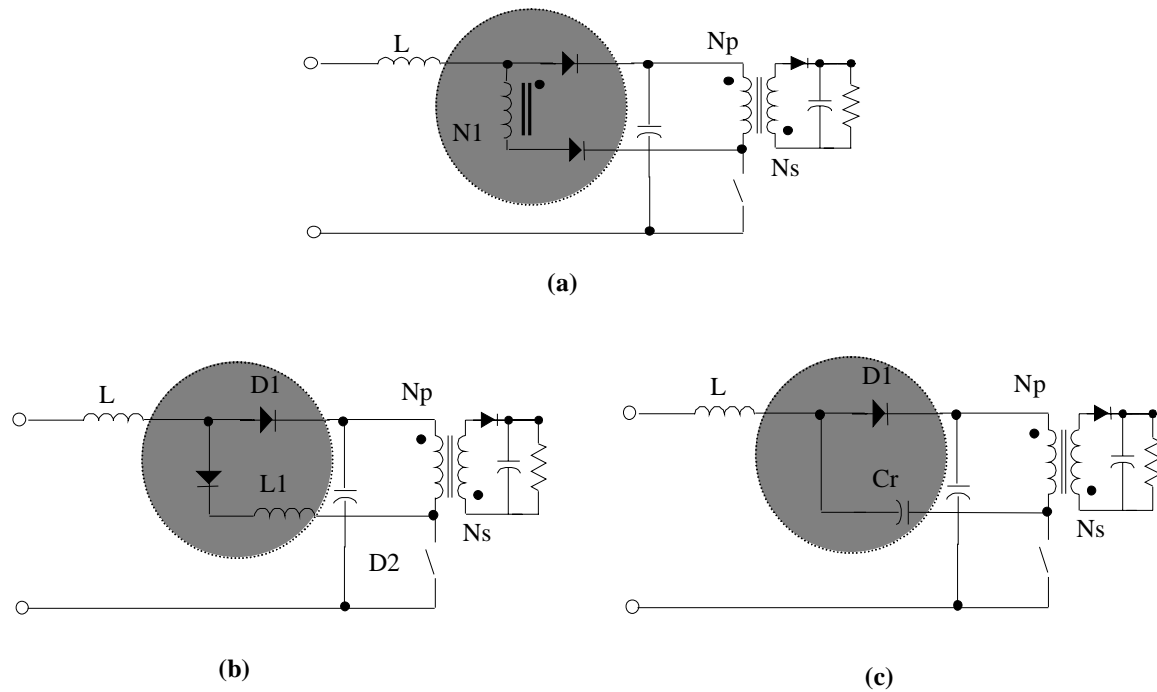

Fig. 2.3 Three terminal integrated single-stage PFC converters

(a) DCM S^2 -PFC converter with N_1 feedback .

(b) CCM current source S^2 -PFC converter .

(c) CCM voltage source S^2 -PFC converter.

stress

and improve the efficiency [B10]. Figure 2.3(b) is the CCM S^2 -PFC converter with an additional

high frequency inductor L_1 to achieve input current shaping [B6, B7]. Because normally the inductor path can be regarded as a current source, in the following section we call it Current Source (CS) S^2 -PFC converter. Figure 2.3(c) is the CCM S^2 -PFC converter with an additional high frequency capacitor C_r to shape the input current [B13]. Because normally the capacitor path can be regarded as a voltage source, in the following section we call it the Voltage Source (VS) S^2 -PFC converter. The function of the high frequency current/voltage source will be discussed also in section 2.3.

The conclusion here is that all these S^2 -PFC converters in Fig. 2.3 have the similar three-terminal PFC cell structure from the circuit topology point of view. Based on the general structure, other combinations of the high frequency sources are also able to be derived to develop new S^2 -PFC topologies. For example, the capacitor C_r in Fig. 2.3(c) can be replaced by a resonant tank, which is a capacitor in series with a inductor. It will also have input current shaping function.

Figure 2.4 shows how to derive the general structure of the two-terminal single-stage PFC converters from the DCM magnetic switch (MS) S^2 -PFC topology. Like the three-terminal PFC cell, the two-terminal PFC cell also has an input inductor and a high frequency source. The difference here is that the PFC-cell here only has two terminals. Same as the high frequency source in three-terminal PFC cell, the high frequency source in the two-terminal PFC cell also can be the different combinations of some passive components.

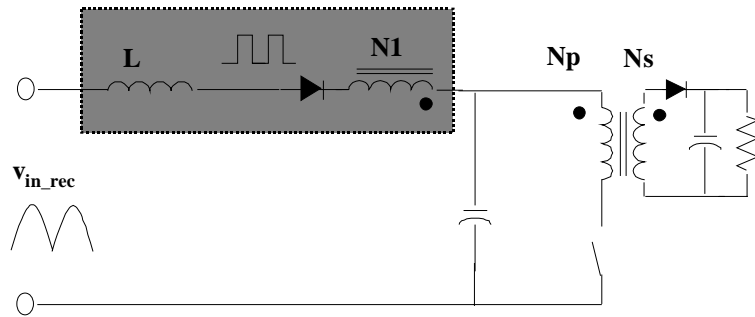

DCM Magnetic Switch PFC Converter [1]

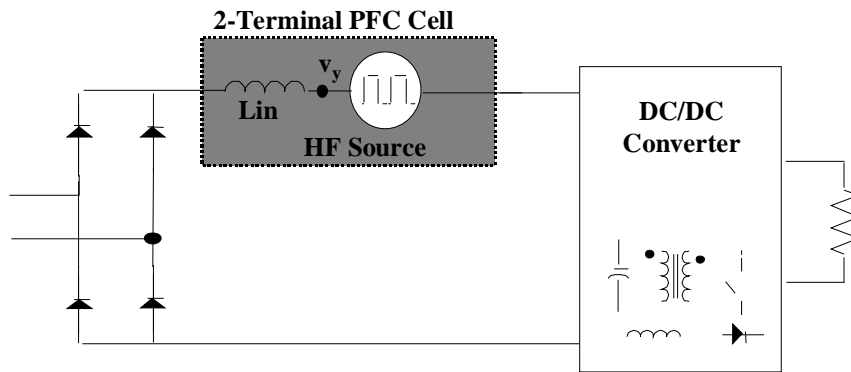
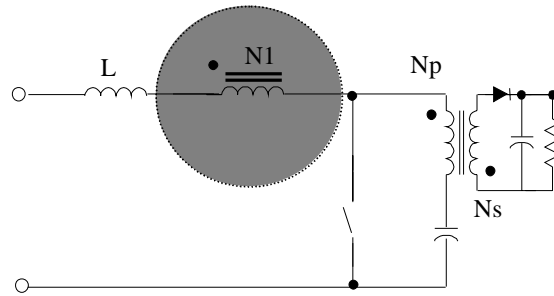
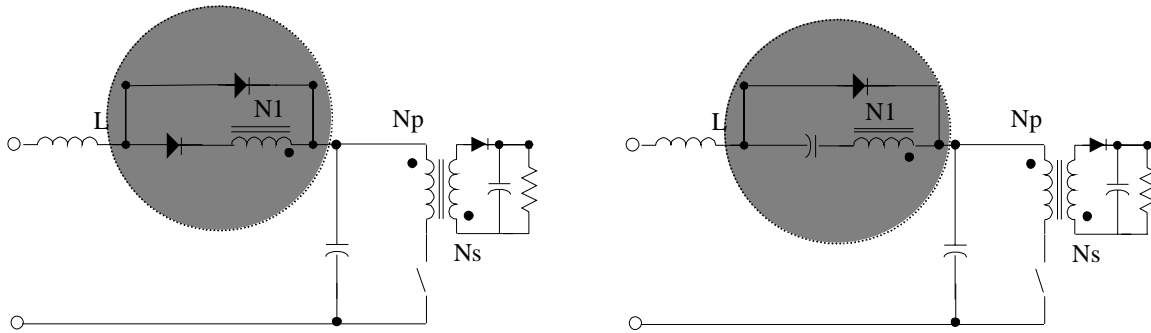

Fig. 2.4 General structure of 2-terminal single-stage PFC converters

Figure 2.5 shows some other S^2 -PFC converters, which have the structure of two-terminal PFC topology. Figure 2.5(a) is the DCM BIFRED S^2 -PFC converter with a feedback winding $N1$. The function of $N1$ is same as the winding $N1$ in the circuit in Fig. 2.3(a). Figure 2.5(b) shows the DCM MS S^2 -PFC converter [B12]. $N1$ in this circuit should be equal or less than the primary side winding Np . If $N1$ is less than Np , it has the same bus voltage feedback effect as the circuit in Fig. 2.5(a). Figure 2.5(b) shows the CCM MS VS S^2 -PFC converter [B12].



(a) BIFRED DCM S^4 -PFC converters with feedback winding N_1



(a) DCM MS single-stage PFC

(b) CCM MS single-stage PFC

Fig. 2.5 Examples of two-terminal single-stage PFC converters

In fact, the two-terminal single-stage PFC topology and three-terminal single-stage PFC topology has a strong relationship. Figure 2.6 shows that the basic two-terminal MS DCM S^2 -PFC converter is the equivalent circuit of the basic three-terminal integrated DCM S^2 -PFC converter if $N_1=N_p$. The circuit operations and the performances of these two circuits are identical except the circuit topologies are different. Figure 2.7 further discloses the equivalence between the two-terminal high-frequency sources and three-terminal high-frequency sources.

Figure 2.8 shows some new circuit topologies based on the equivalent relationship and the two-terminal general structure. Figure 2.8(a) is a new CCM MS CS S^2 -PFC converter, which is the equivalent circuit of the circuit in Fig. 2.3(b). Figure 2.8(b) is just a varied circuit of the circuit in Fig. 2.8(a). Figure 2.8(c) is the combined circuit of Fig. 2.8(a) and Fig. 2.5(c).

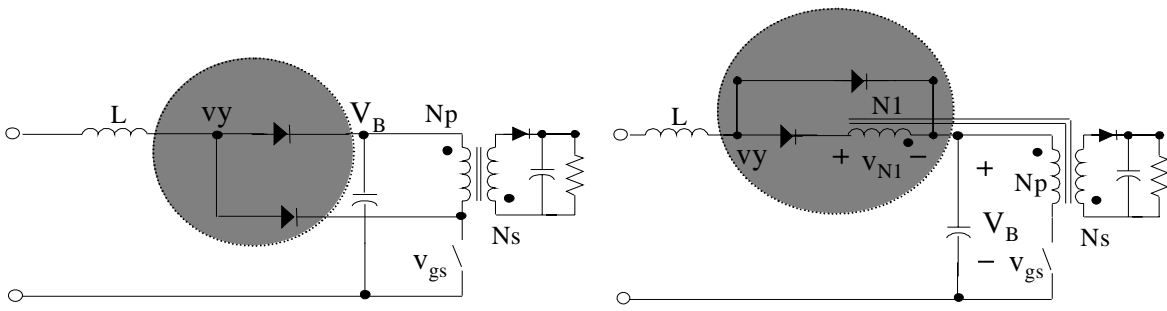

DCM integrated single-stage PFC

DCM MS single-stage PFC ($N_1=N_p$)

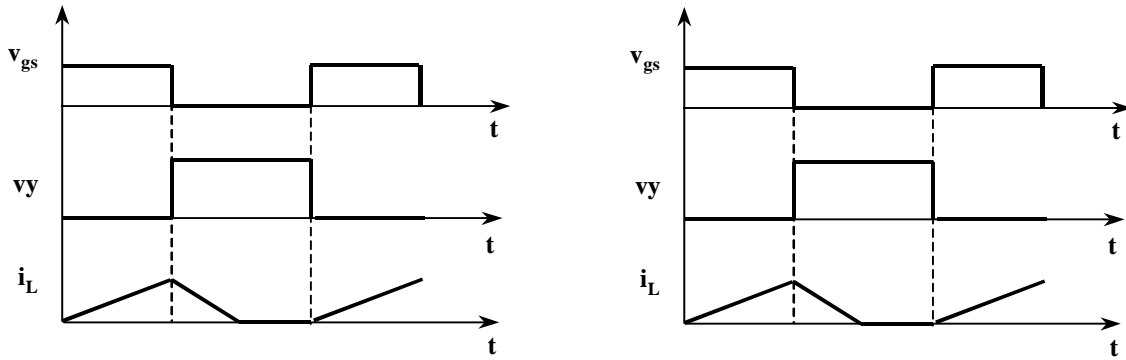

Fig. 2.6 Equivalent relationship between three-terminal and two-terminal S^2 -PFC converters

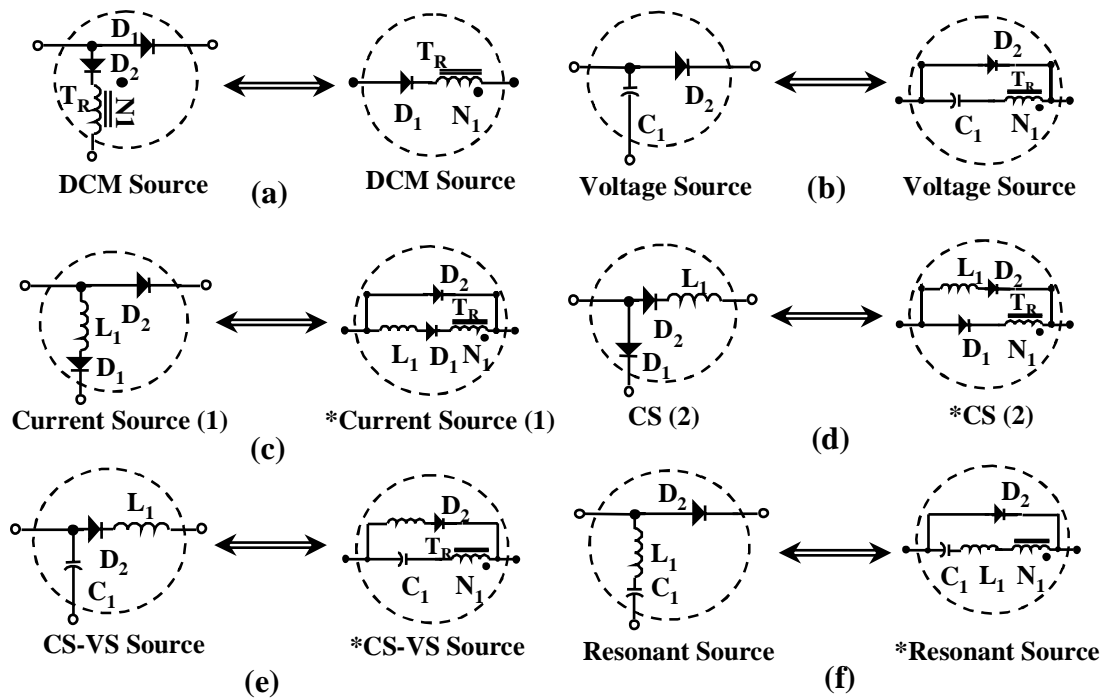

Fig. 2.7 The equivalent relationship between two families of high frequency sources (* High frequency sources for new topologies)

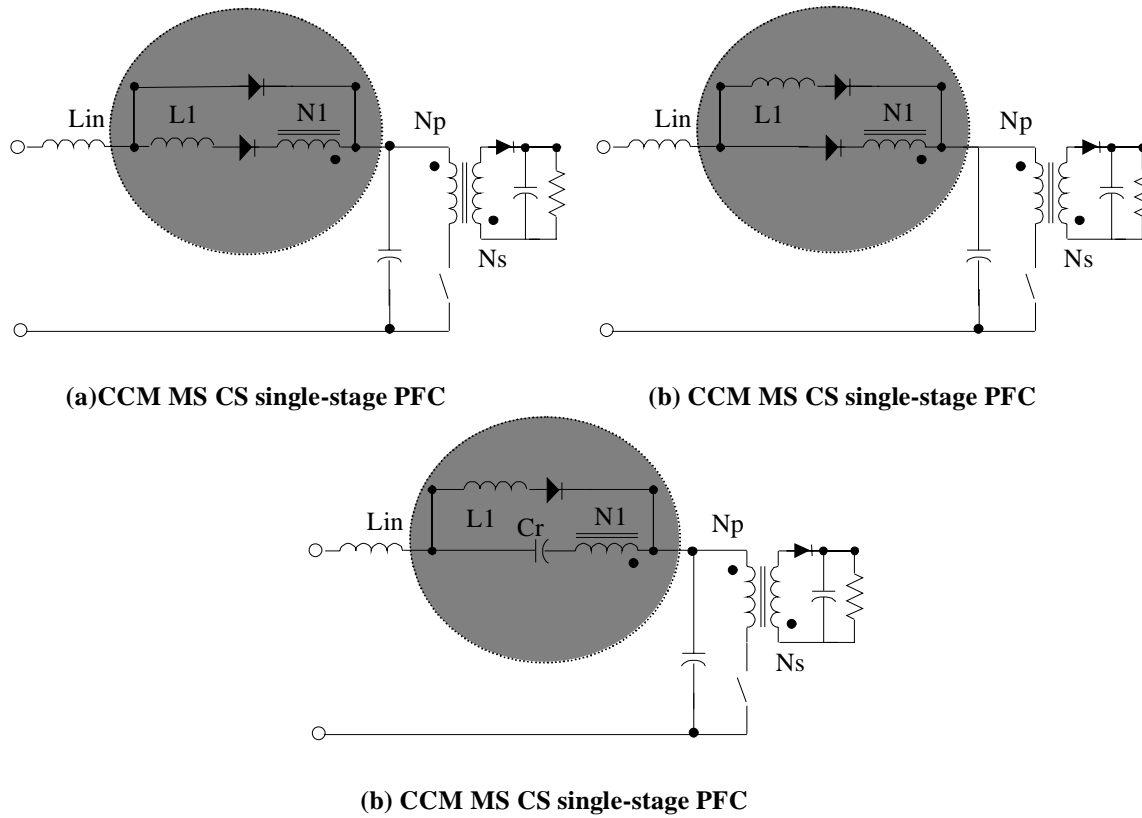

Fig. 2.8 Novel CCM Two-terminal single-stage PFC converters

Fig. 2.9 shows the input inductor current waveforms of two equivalent CCM CS single-stage PFC converters with two-terminal and three-terminal high-frequency sources, respectively. If the circuit parameters and specifications are same, as can be seen from Fig. 2.9, the input inductor current waveforms of these two circuit are identical. The S^2 -PFC converters with these two equivalent high-frequency sources are also equivalent if $N_1=N_p$, where N_p is the primary side transformer winding.

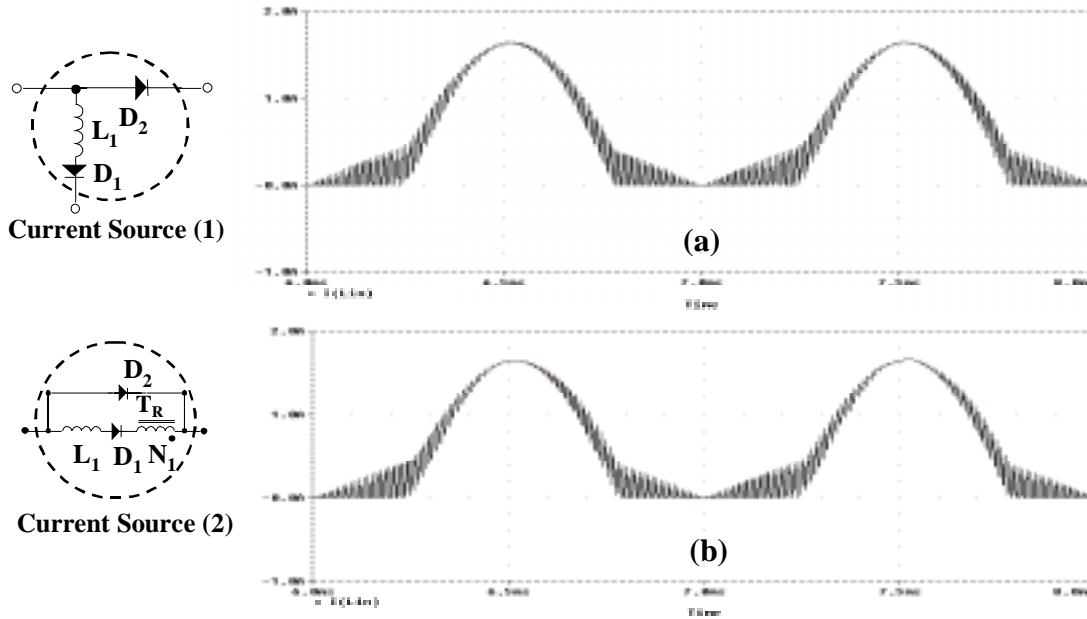

Fig. 2.9 The input inductor current waveforms
(a) Three-terminal current source single-stage PFC converter
(b) Two-terminal current source single-stage PFC converter.

So far, the general structures of integrated PWM single-stage PFC converters are identified. The common structure of the PFC cell is an input-current-shaping inductor followed by a two-terminal or three-terminal high frequency source. Based on this structure, we can discover the basic principle of single-stage PFC converters.

2.3. Necessary condition of single-stage PFC converters

2.3.1. Dither concept

As shown in Fig. 2.10, the diode rectifier has high distorted input current because the converter only absorbs current when the instantaneous input voltage v_{in_rec} is higher than the dc capacitor voltage V_{Cb} . Because the impedance of L_k is small and the conduction angle of L_k is very narrow, the input current has rich harmonic current and cannot meet the PFC regulation. Even if the parasitic inductor L_k is replaced with a larger value passive inductor, the conduction

angle is still not large enough to provide good input current until the inductor is a bulk high cost low frequency filter inductor, which has large size and high cost.

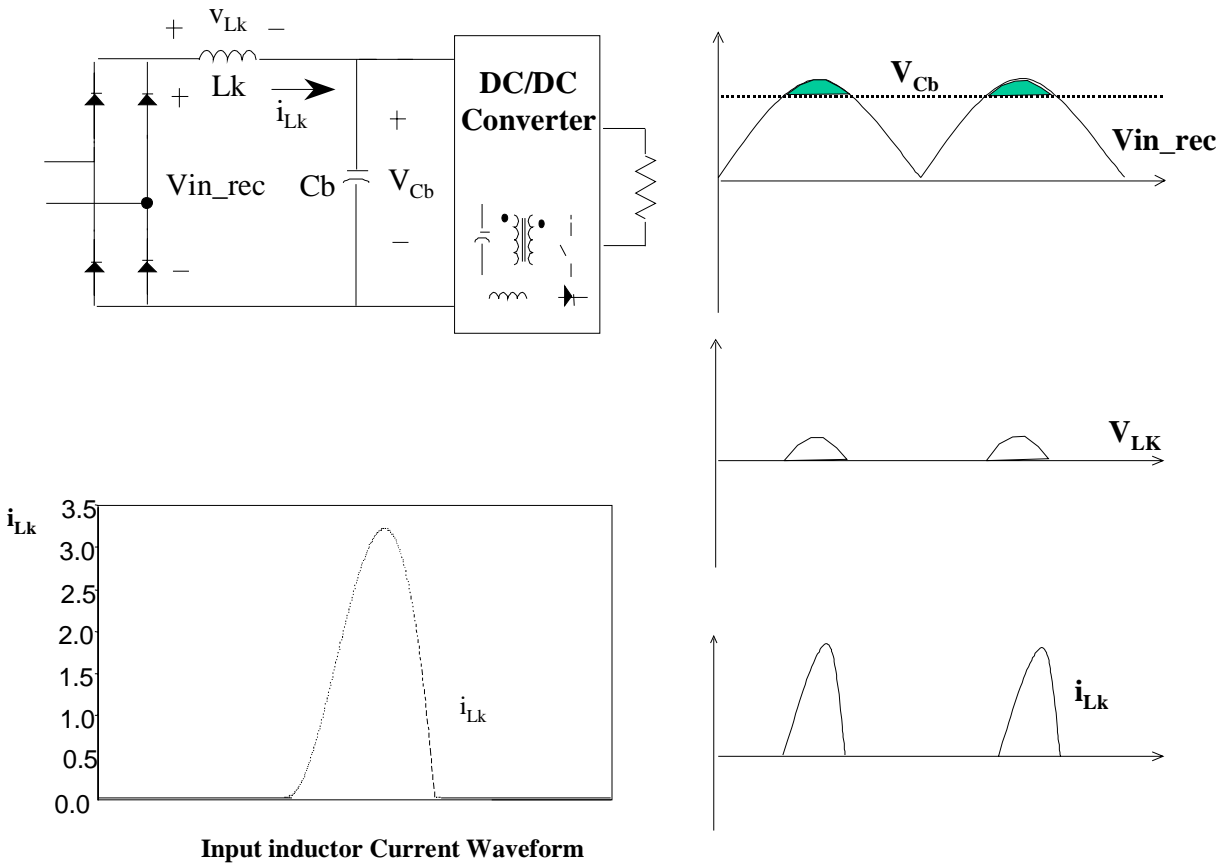

Fig. 2.10 The circuit waveforms of conventional diode rectifier

However, for single-stage PFC topologies in Fig. 2.3 and Fig. 2.5, because of the existence of the high frequency source, the input current waveform is much better with a small size high-frequency inductor. The reason for this is that the high frequency source changes the instantaneous voltage v_y from a constant dc voltage into a pulsating high frequency voltage. It helps the rectifier to get better input current waveform than the conventional diode rectifier.

From enlarge the input current conduction angle point of view, the dither concept is introduced by [B14] to explain the principle of DCM single-stage PFC converter. Figure 2.11 can be used to explain the input current shaping function of DCM S^2 -PFC converters.

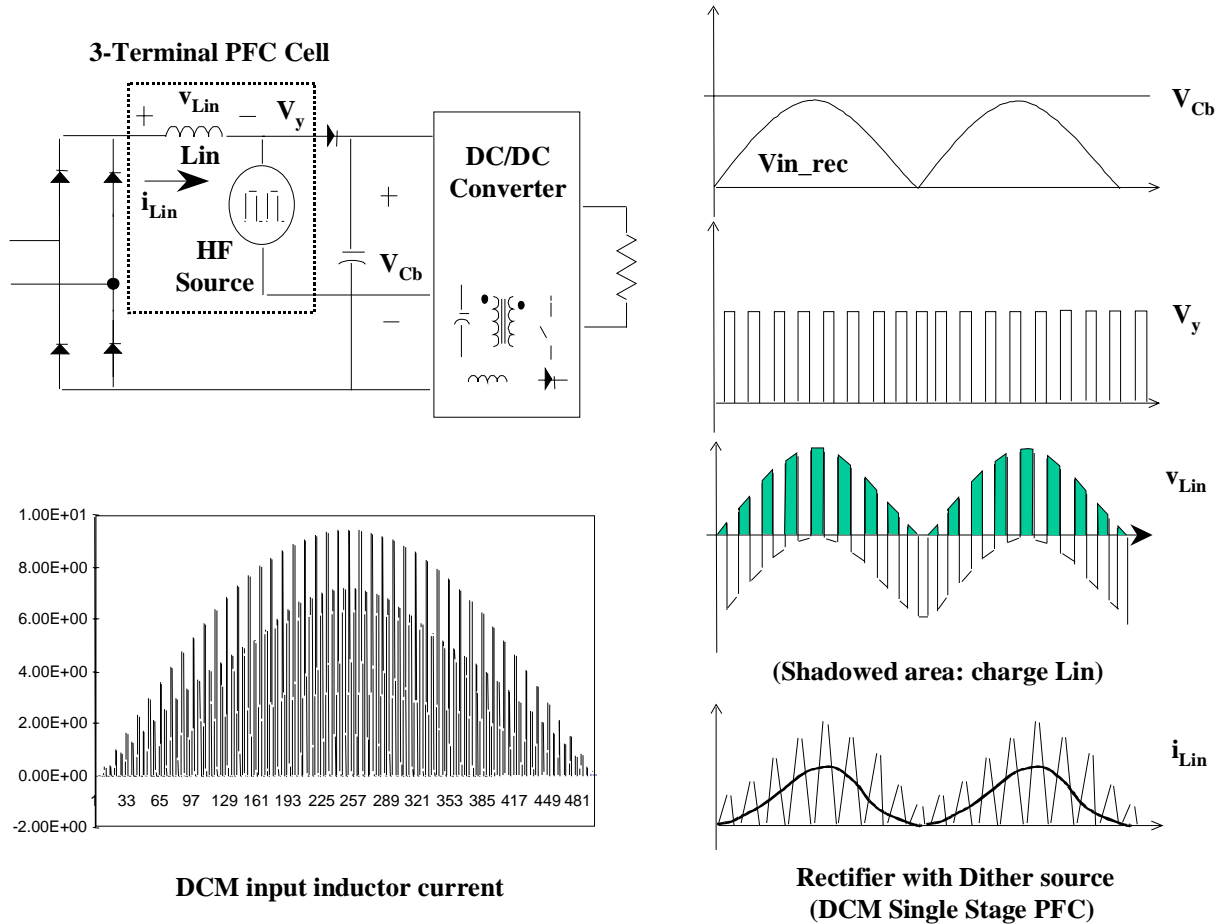
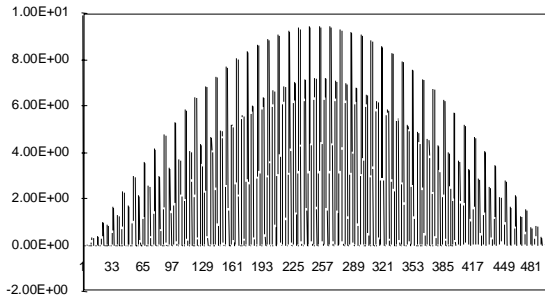
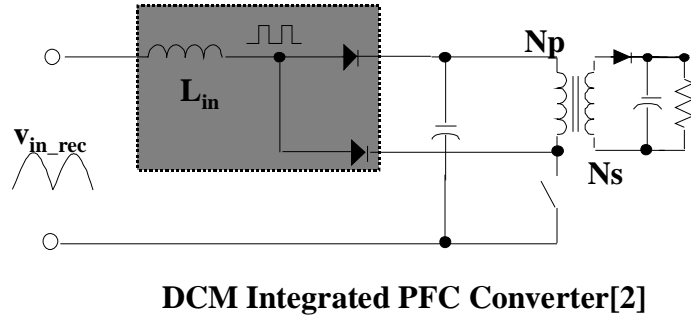

Fig. 2.11 The circuit waveforms of DCM single-stage PFC converter with high frequency dither source concept

In the two/three-terminal PFC cell, the high frequency source is called dither source as in [B14]. The circuit waveforms show that the input current dead conduction angle in Fig. 2.10 is eliminated with the help of dither source. As a result, the input conduction angle is enlarged and the input current peak is reduced. Therefore, comparing the inductor current waveforms in Fig.

2.10 and Fig. 2.11, the latter one has a much nicer waveform and results in a lower THD and a better input power factor.



DCM Operation

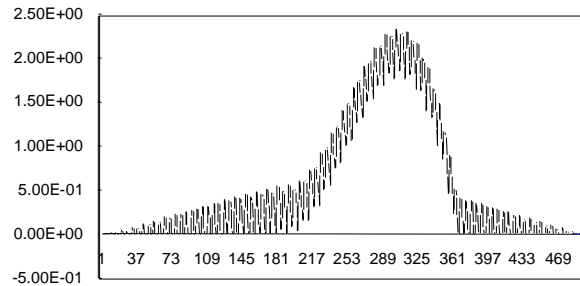

CCM Operation

Fig. 2.12 Different input inductor currents for DCM and CCM operations

As presented before, the CCM S^2 -PFC converters are very desirable for many applications because they have better efficiency and smaller EMI filter compared to DCM S^2 -PFC converters. Therefore, it is necessary to understand the PFC function of the CCM S^2 -PFC converters. Figure 2.12 shows the same converter has very nice input inductor current waveform in DCM operation but distorted input inductor current if it is operated in CCM mode. Of course, with the help of the dither source, the input current is already much better than the input current of the diode rectifier. However, this current still has high peak and high distortion and cannot

meet the PFC regulation. The dither concept can be used to explain why the DCM S^2 -PFC converter has better power factor than a diode rectifier. But it cannot further explain why when this circuit is running in CCM, the input current waveform is not good. Also, the dither concept cannot help us to find and explain new CCM single-stage PFC circuit. Therefore, a new concept must be introduced to explain the principle of CCM single-stage PFC converters.

2.3.2 Derive the necessary PFC condition from ideal CCM boost converter

The existence of a high frequency source changes the voltage v_y , therefore, the input current shaping is automatically achieved with constant duty-cycle control. In order to further understand the PFC principle of the PFC cell, one direction of research is to focus on the average value of pulsating signal v_y to find out what kind of $\langle v_y \rangle$ will help the input inductor get good input current. Figure 2.13 shows that it is possible to find out the inside principle if the study focuses on the common point v_y in all the integrated single-stage PFC converters.

Because CCM boost PFC converter has an ideal sinusoidal input current, it will be simple if we start to find what kind of $\langle v_y \rangle$ waveform is in an ideal CCM PFC converter. The large signal average model of CCM boost converter is derived for this study. Figure 2.14 (a) shows the CCM boost PFC converter. R_{load} represent the load converter and the equivalent resistance can be get from Eq. 2.1. Based on the three-terminal PWM switching cell model, the average circuit model is given in Fig. 2.14 (b). The switch and diode are replaced by continuous current and voltage sources. Based on this continuous average model, the equation of v_y can be derived.

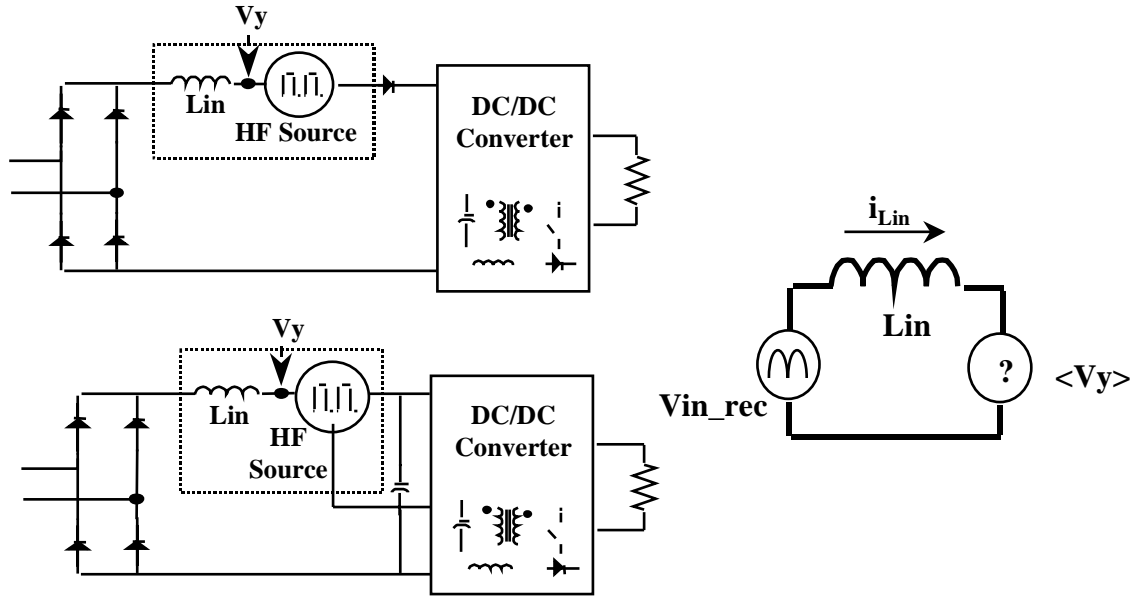

Fig. 2.13 Focus on $\langle v_y \rangle$ to study the principle of PFC cell

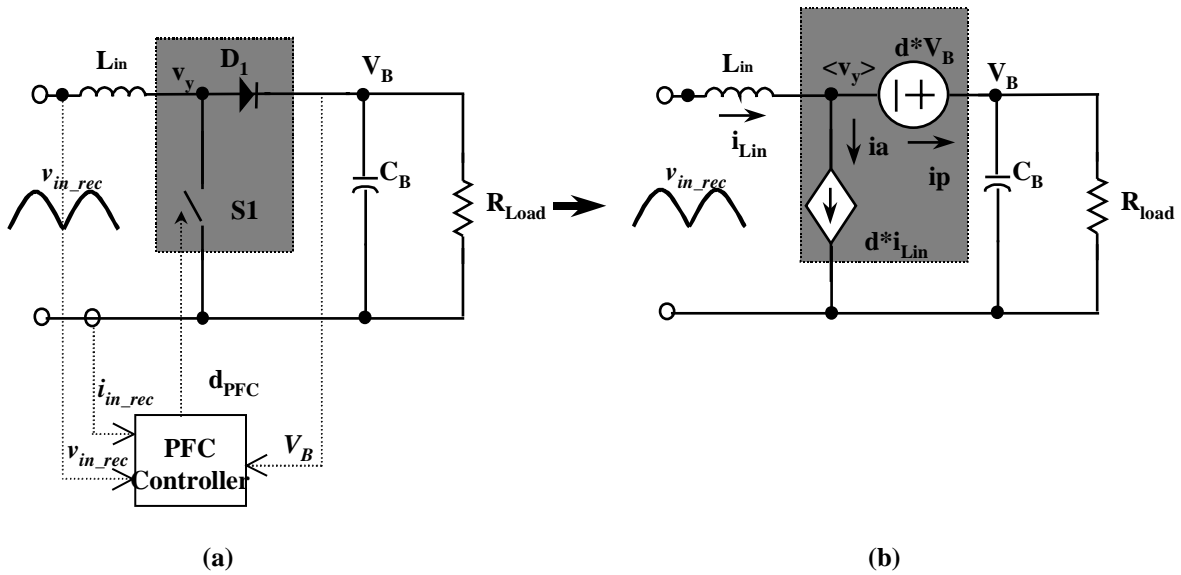

Fig. 2.14 CCM boost PFC converter and its average model

If the converter loss is ignored, then, Eq. 2.1 is given based on the input and output power balance relationship. In this equation, the P_o is the output voltage, and V_{in} and I_{in} are the peak

$$P_o = \frac{1}{2} \cdot V_{in} \cdot I_{in} = \frac{V_B^2}{R_{Load}} \quad (2.1)$$

values of input voltage and current respectively. V_B is the output bus capacitor voltage.

For an ideal PFC converter, the input voltage and current should be pure sinusoidal waveforms. Therefore, the following equations are given:

$$v_{in_rec} = Vin \cdot |\sin wt| \quad (2.2)$$

$$i_{Lin} = Iin \cdot |\sin wt| \quad (2.3)$$

In Eq. 2.2, v_{in_rec} is the rectified input voltage and ω is the line frequency.

From the average circuit model in Fig. 2.14, Eq. 2.4 and 2.5 are also derived as:

$$\langle v_y \rangle = (1 - d) \cdot V_B \quad (2.4)$$

$$v_{in_rec} - \langle v_y \rangle = L_{in} \cdot d(i_{Lin})/dt \quad (2.5)$$

From Eq. 2.1 to Eq. 2.5, the equation of duty cycle $d(t)$ is derived as shown in Eq. 2.6 and the equation of $\langle v_y \rangle$ is given in Eq. 2.6.

$$d(t) = 1 - \frac{\langle v_y \rangle}{V_B} = 1 + \frac{2L_{in}P_o}{Vin} \cdot \frac{d(|\sin wt|)}{dt} - Vin \cdot |\sin wt| \quad (2.6)$$

$$\langle v_y \rangle = v_{in_rec} - \langle v_{Lin} \rangle = Vin |\sin wt| - \frac{2L_{in}P_o}{Vin} \cdot \frac{d(|\sin wt|)}{dt} \quad (2.7)$$

Equation 2.6 shows the $\langle v_y \rangle$ equation of an ideal CCM boost converter. It shows that $\langle v_y \rangle$ has two terms; the first one is the rectified input voltage v_{in_rec} and the second one is the average inductor voltage $\langle v_{Lin} \rangle$. To get a clear idea about which term is dominant, we can give some practical numbers for all the circuit parameters and specification. Assuming the input rms voltage is 230 Vac, the peak value of the first term is 325 V. Also assuming the output power P_o

= 1 KW, the input inductor $L_{in} = 2$ mH and the line frequency is 60 Hz, then the peak value of the second term is 4.9 V. It is clear that the peak value of the second term is much less than the peak value of the first term. So the first term is the dominant term. Figure 2.15 shows the waveform of the first term v_{in_rec} and the second $\langle v_{Lin} \rangle$ with the previous assumption. In Fig. 2.15 (a), there are two very close curves; one is the v_{in_rec} and the other is $\langle v_y \rangle$. They are so close that it looks like there is only one curve. Figure 2.15(b) is the voltage difference between v_{in_rec} and $\langle v_y \rangle$, i.e., the inductor voltage $\langle v_{Lin} \rangle$. The magnitude of this curve is just less than 5 V.

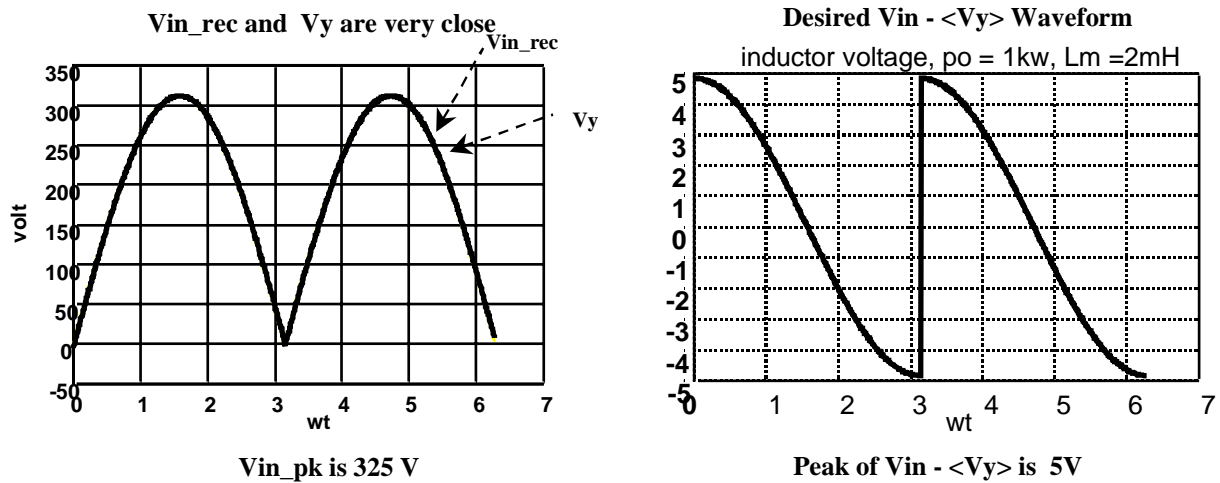

Fig. 2.15 Circuit waveforms of the CCM boost PFC average model

One fact is shown in the previous calculation: the rectified sinusoidal voltage waveform is the dominant term in the equation of v_y in the ideal CCM PFC converter. This is reasonable because the PFC inductor is a high frequency inductor, which has a small inductance. It should not have a large low frequency voltage on it. However, although the second term $\langle v_{Lin} \rangle$ is a small value, it determines the perfect sinusoidal input current waveform.

The study of the ideal CCM boost PFC shows that during the line cycle, $\langle v_y \rangle$ follows v_{in_rec} with just a very small difference. As the single-stage PFC converters are concerned, normally it is hard to derive the mathematical equations of $\langle v_y \rangle$ and identify the first and second terms. However, according to the study of ideal boost PFC converter, it is reasonable to assume that any single-stage PFC converter with an input inductor also has the similar relationship between $\langle v_y \rangle$ and v_{in_rec} .

Based on the observation of the CCM boost PFC converter, a **necessary PFC condition** is generated as: **any good PFC converter, the average voltage $\langle v_y \rangle$ must roughly follow the rectified input voltage v_{in_rec} .**

Of course there will be a small difference between v_{in_rec} and $\langle v_y \rangle$. In Eq. 2.6, the second term shows this difference. For most CCM single-stage PFC converters, it is impossible to derive the mathematical circuit equations. It is also impossible to get the $\langle v_y \rangle$ equation and identified the first and second terms then find out how good the input current is. Therefore, we only get the previous necessary PFC condition. Even so, it is already stronger than the dither concept for us to understand present CCM PFC converters.

2.3.3 Verifications of the necessary PFC condition

The necessary PFC condition can be verified with several current single-stage PFC converters.

Figure 2.16 shows the circuit operating waveforms of DCM integrated single-stage PFC converter. It has good input power factor and it meets the necessary PFC condition. Because of

the DCM operation of input inductor current, every switching cycle, inductor current is always discharged back to zero. It means $\langle v_y \rangle = v_{in_rec}$.

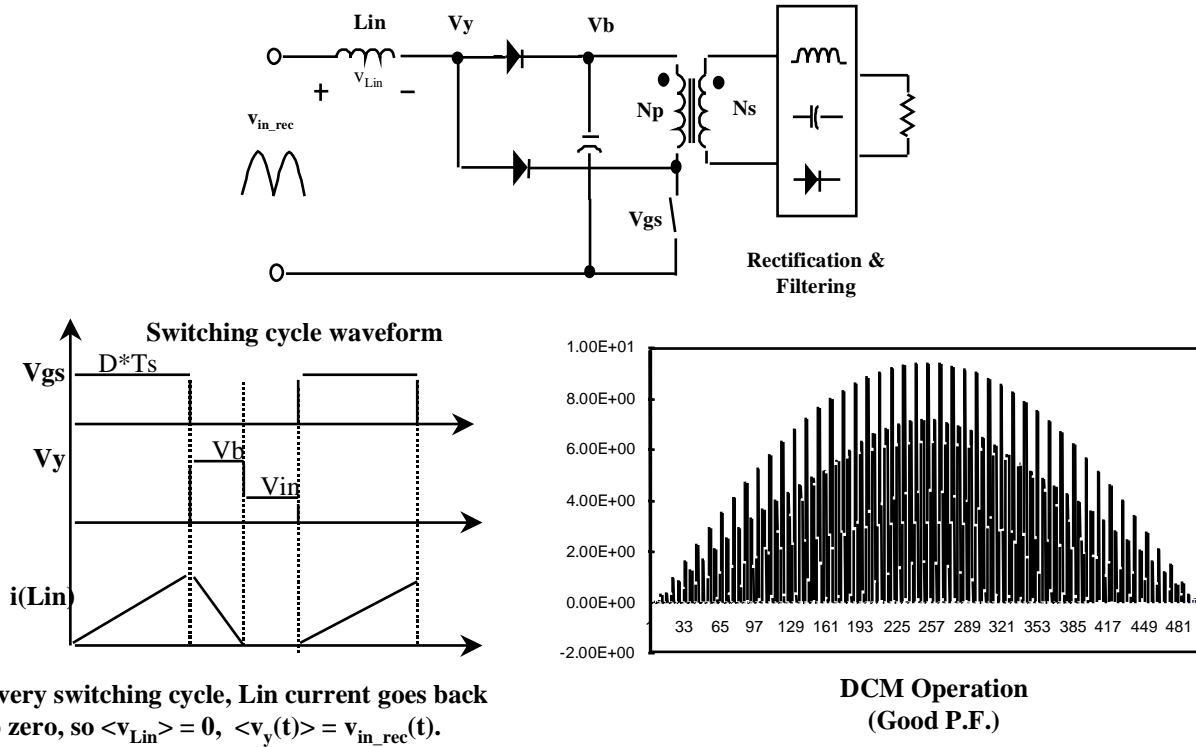

Fig. 2.16 DCM integrated single-stage PFC waveforms

However, if this circuit is pushed into CCM mode, Fig. 2.17(a) shows how the switching cycle waveforms will be different. When the switch is turned on, the instantaneous v_y value is zero. When the switch is turned off, the instantaneous v_y value is equal to V_B . Because the duty-cycle is constant during a line cycle, so the average value of v_y over a switching cycle is also a constant value: $\langle v_y \rangle = D \cdot V_B$. D is the steady state duty cycle here. So it no longer meets the necessary PFC condition and Fig. 2.17(b) shows the input current waveform will have high peak and high distortion. It can not meet the IEC PFC regulation any longer.

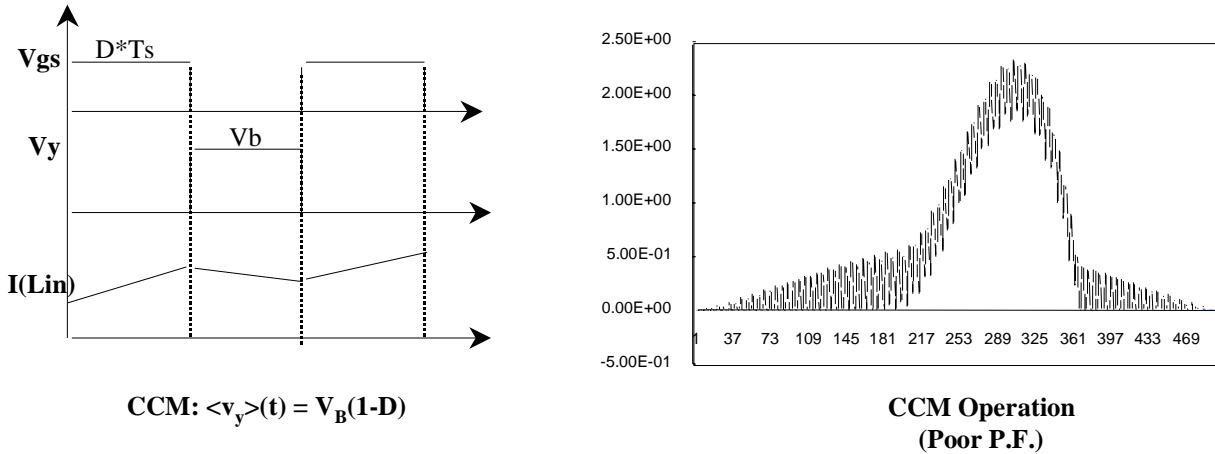

Fig. 2.17 Operate the DCM single-stage PFC converter in CCM mode

To make $\langle v_y \rangle$ follow the rectifier input voltage waveform to meet the necessary PFC condition, one approach is to replace the bottom diode in the DCM single-stage PFC converter with a high frequency capacitor. It is the CCM VS S2-PFC converter as shown in Fig. 2.18 (a). Figure 2.18 (c) and (d) show the switching cycle waveforms while the input current is at a different value. The shadowed area of the v_y is the additional part due to the capacitor C_r . When the input voltage increases instantaneously, the input current also increases as shown in Fig. 2.18(b). Figure 2.18(c) and (d) show that when the input current increases from $t = t_a$ to $t = t_b$, the positive part of the shadowed area also increases and therefore the average value $\langle v_y \rangle$ increases. So with the help of the capacitor C_r , $\langle v_y \rangle$ can roughly follow v_{in_rec} and meet the necessary PFC condition. It explains why this circuit has fair input current shaping function. Figure 2.19(a) and (b) shows the input inductor current waveform without and with C_r , respectively.

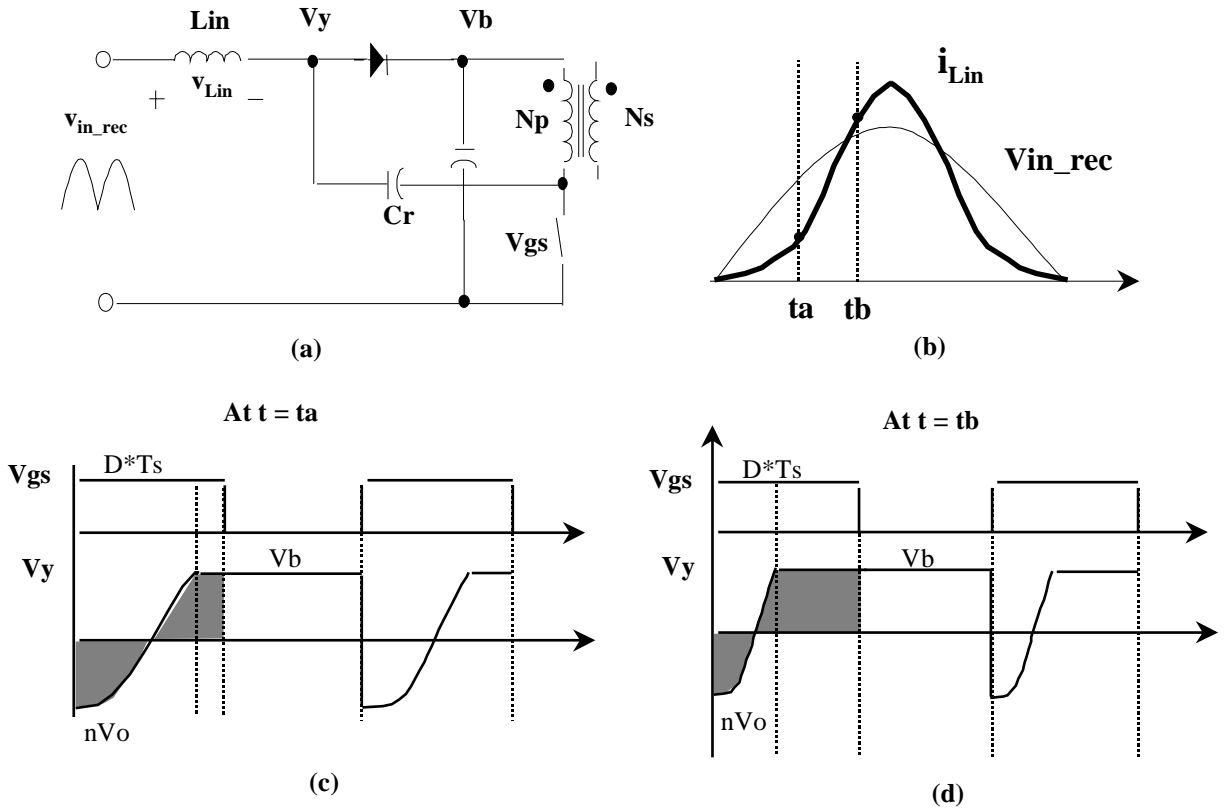

Fig. 2.18 Circuit waveforms of VS CCM S²-PFC converter

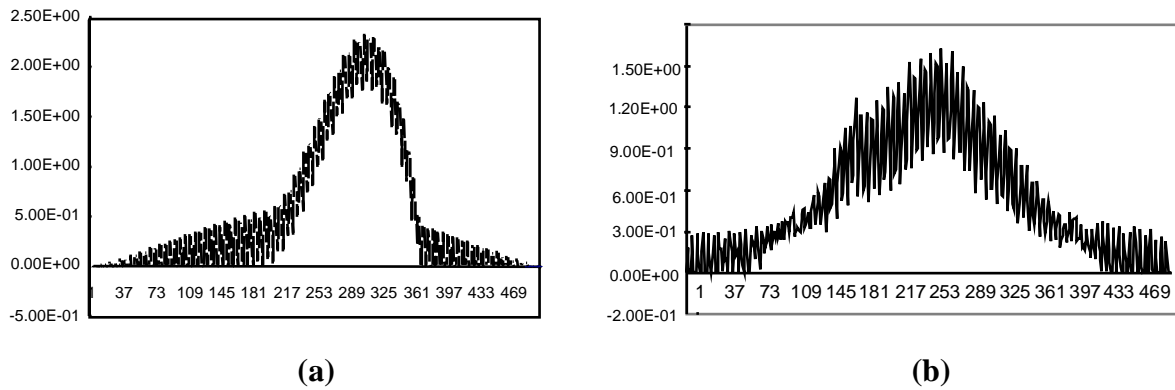

Fig. 2.19 Input inductor current waveforms
 (a) Push DCM S²-PFC into CCM
 (b) VS CCM S²-PFC converter

Another typical CCM S²-PFC converter is the CS CCM S²-PFC converter. In this converter, an additional inductor L_1 is added in series of the bottom diode in the DCM S²-PFC

converter to help $\langle v_y \rangle$ follow the input voltage waveform to meet the necessary PFC condition. Figure 2.20 (a) shows the circuit of CS CCM S^2 -PFC converter. Figure 2.20(c) and (d) show the switching cycle waveforms. The shadowed area of v_y is the additional area due to the additional inductor L_1 .

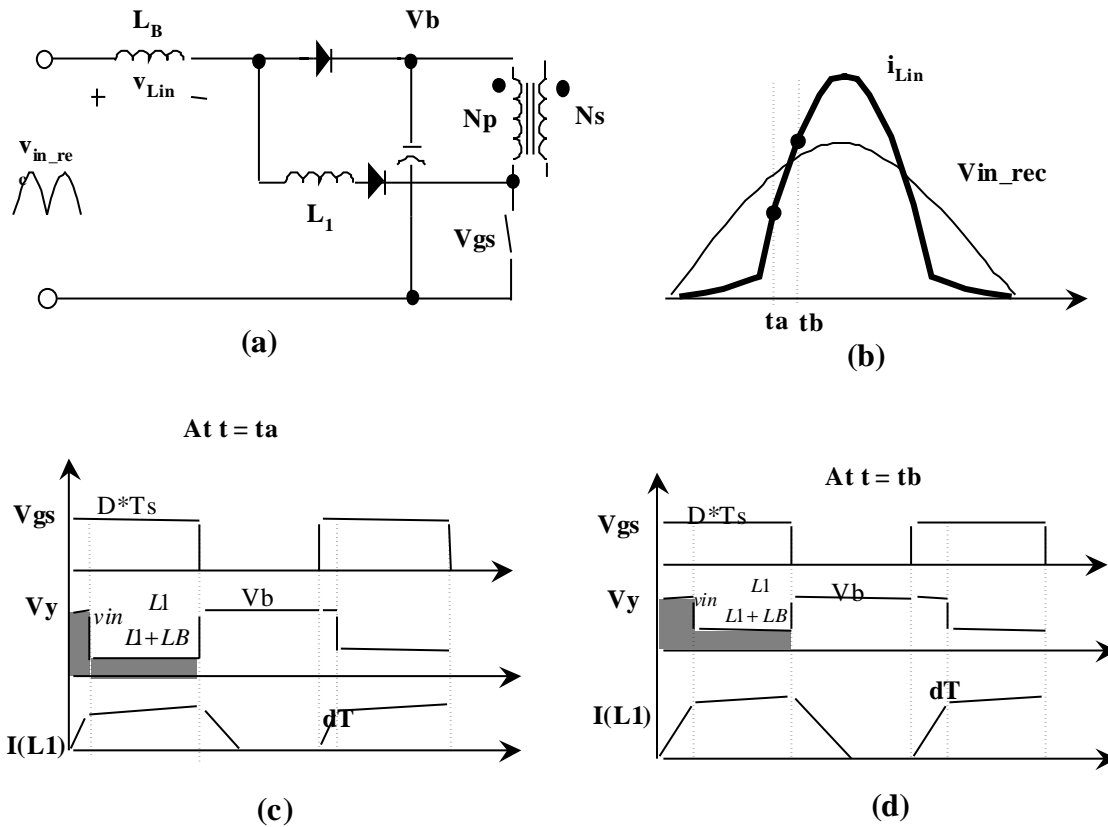

Fig. 2.20 Circuit waveforms of CS CCM S^2 -PFC converter

When the input instantaneous voltage increases, as shown in Fig. 2.20(b), the input current also increases. The additional shadowed area in v_y also increases with the increase of the input current. Therefore, the average continuous value $\langle v_y \rangle$ increases. So with the help of L_1 , $\langle v_y \rangle$ can roughly follow the rectified input voltage and meet the necessary PFC condition. It explains why this converter has better CCM input current waveforms than the previous circuit

does without L1. Again, Fig. 2.21 (a) and (b) shows the input inductor current waveform without and with L1, respectively.

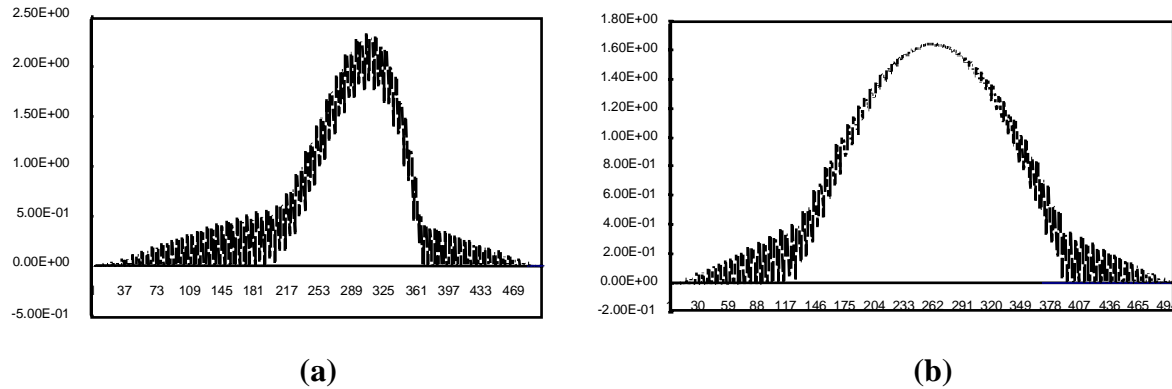

Fig. 2.21 Input inductor current waveforms
(a) Push DCM S^2 -PFC into CCM
(b) CS CCM S^2 -PFC converter

In conclusion, three typical existing single-stage PFC converters verified the necessary PFC condition.

2.4 Summary

In this chapter, the generalized structures of integrated single-stage PFC converters have been derived. The basic PFC cells are identified and classified. New integrated single-stage PFC topologies are also developed.

Based on the generalized structure, the basic principle of single-stage PFC converter has been studied. It shows the current dither concept is not good enough to explain the input current shaping function of the existing CCM single-stage PFC converters. Therefore, the ideal CCM boost converter is studied and the necessary PFC condition is generated. It shows that for a good

PFC converter with input inductor, the voltage after the inductor must have an average value, which can roughly follow the rectified input voltage. It is verified with the three typical single-stage PFC converters. This condition can be used not only to explain why the present CCM single-stage PFC converter can have good input power factor, but also to check the possibility if any new topology has the PFC function.