

Chapter 1: Introduction and Literature Review

1.1 Introduction to Bearing Technology

Ball bearing technology has evolved from the earliest time of pyramid construction. Ancient wall carvings show the use of bearings created by successively laying roller-type barrels or trees one after the other, across which heavy items could be rolled [Harris]. Since then, mechanical evolution has increased the need to reduce friction and improve bearing technology.

Ball bearings and roller bearings can both be classified as “rolling bearings”. All forms of bearings utilize the rolling action of balls and/or rollers to minimize friction and to constrain motion of one body relative to another. Even though there are many different type of rolling bearings, they all consist of the same general components:

1. A complement of balls and/or rollers which maintain the shaft and a usually stationary structure in a radially spaced relationship,
2. Two usually steel rings each of which has a hardened raceway on which hardened steel balls or rollers roll
3. A cage or separator (retainer) which holds rolling elements in an angularly spaced relationship.

Prior to the extensive use of rolling bearings, hydrodynamic bearings were used. Hydrodynamic bearings make use of a lubricant between the interacting surfaces, which, when in operation, forms a fluid gap. In comparison, rolling bearings have several benefits over hydrodynamic bearings, which are [Harris]:

1. Lower friction torque
2. Static friction torque is only slightly higher than kinetic friction torque
3. Rolling bearing deflection is less sensitive to load fluctuations than is deflection in a conventional hydrodynamic bearing.
4. Rolling bearing only need a small quantity of lubrication for satisfactory operation.
5. Rolling bearings occupy a shorter axial length than conventional hydrodynamic bearings.

6. Within reasonable limits, changes in load, speed and operating temperature have only slight effect on satisfactory performance of a rolling bearing.
7. Most rolling bearings are designed to support combination of radial and thrust load simultaneously.
8. There is a fairly wide range of load and speed that rolling bearings may be subjected and still yield excellent performance.

Even though rolling bearings have the aforementioned advantages, there exists one principal shortcoming of rolling bearings, “...even if rolling bearings are properly lubricated, properly mounted, protected from dirt and moisture, and otherwise properly operated, they will eventually fail because of fatigue of the surfaces in rolling contact” [Harris].

1.2 Double Row Ball Bearings

Even though in many cases single row ball bearings may be used, double row ball bearings were developed because, in some applications, they have advantages over single row bearings. Double row ball bearings can carry an increased radial load in comparison to that of its single counterpart. According to the AFBMA (Anti-Friction Bearing Manufacturers Association) capacity formula, the number of rows of balls increases the bearing capacity by the factor $(i \cos(\alpha))^{0.7}$ where i is the number of rows and α is the internal contact angle. Double row bearings also limit the axial motion of the shaft to which it is attached. Axial movement can be reduced to values approximately 0.001 to 0.004 inches depending on the bearing size [Morton].

1.2.1 Early and Modern Examples of Double Row Bearing

Morton, [1965] cites the following references to the use of double row bearings in the literature:

- A. F. Mannon, under a patent for a wheel hub that contained a double row ball bearing. His bearing was adjusted for preload by screwing the outer rings closer to each other.
- W. Clark patented a double row bearing with small balls in a third row which acted as separators to prevent the balls from rubbing against each other (Figure 1.1).
- Figure 1.2 shows four early successful, patented double row ball bearings. All have filling slots.

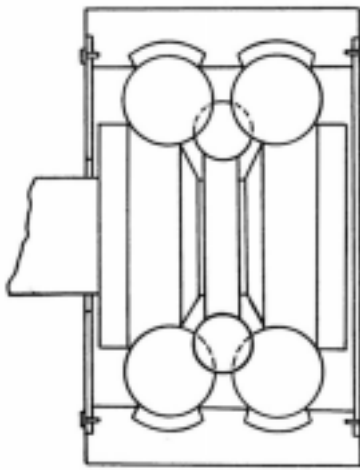

Figure 1.1 W. Clark's double row bearing with separator balls.

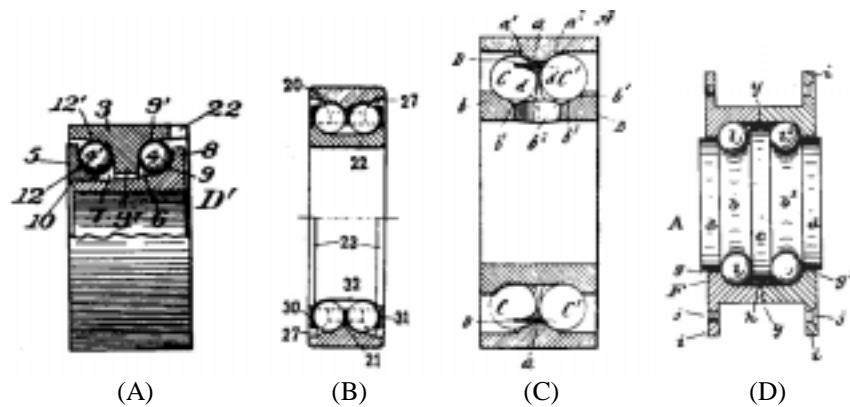

Figure 1.2 Early double row ball bearings. (A) USA patent 537,152, April 9 1895 M.J. Herbert, (B) DRP patent 210,156, August 14 1906 E. Sachs, (C) English patent 19,470, June 11, 1909 F.E. Bright, (D) USA patent 921,464 May 11, 1909 A.F. Rockwell

These early double row ball bearings have proceeded through technological advancements into many different forms and uses, a few of which are illustrated in Figure 1.3.

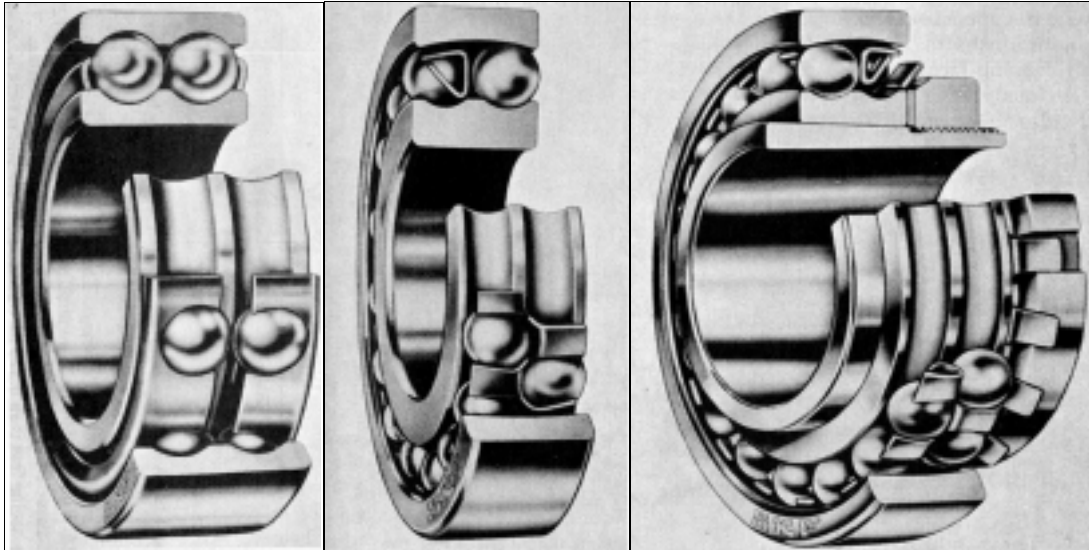

Figure 1.3 A few examples of modern double row bearing technology. (left) double row, deep groove ball bearing, (middle) a double row internally self-aligning ball bearing assembly and (right) a double row internally self-aligning ball bearing assembly with a tapered sleeve and locknut adapted for simplified mounting on a shaft of uniform diameter [Harris].

1.3 Bearing Assembly

There are a variety of methods to assemble ball bearings, both single and double row, and there are two basic bearing configurations that aid in the assembly process, namely, slotted and unslotted. Slotted assembly type bearings have filling slots cut axially through the shoulder on one side of each ring, Figure 1.4. This slot allows the introduction of as many balls as permitted by the retainer and the pitch circle. The increased number of balls adds to the radial load carrying capacity of the bearing. Even though the filling slot may aid in the assembly process, under axial loading the balls will contact the filling slot, causing noise and poor performance. The unslotted, or Conrad, bearing is the bearing assembly type to be addressed in this thesis. The Conrad bearing is

probably the most commonly used. The inner and outer races have deep uninterrupted grooves with circular cross sections whose radii are only slightly larger than that of the balls. The Conrad method of assembly for single row ball bearings is illustrated in Figure 1.5 and 1.6. The inner ring is initially offset inside the outer ring. In most cases, including the double row bearing, the outer ring is slightly distorted to increase the clearance for ball insertion. With the inner ring offset, balls are inserted (Figure 1.5a and Figure 1.6). After the balls are inserted the inner ring is snapped to a position concentric with the outer ring (Figure 1.5b), the balls are separated uniformly (Figure 1.5c) and a cage is inserted to maintain the ball separation. Note that this method limits the number of balls that can be inserted, which limits the bearings radial load carrying capacity.

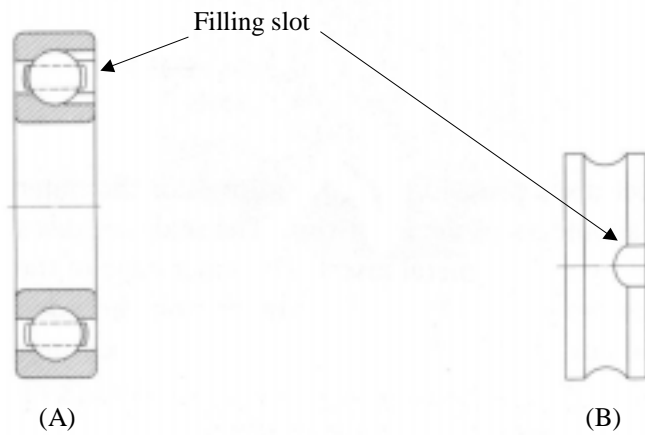

Figure 1.4 (A) Deep groove ball bearing with filling slot, (B) Inner ring of a deep groove ball bearing with filling slot [Eschmann].

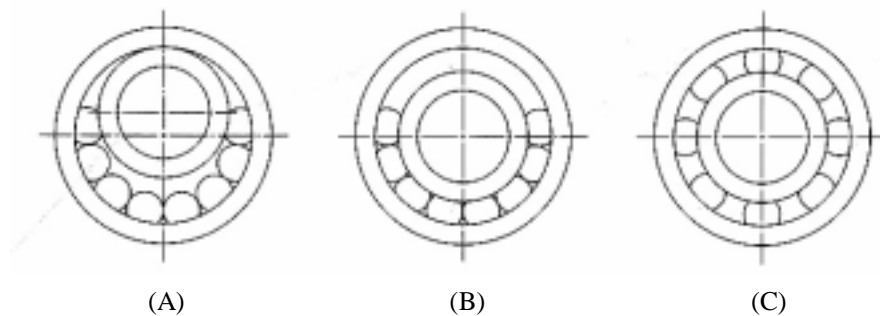

Figure 1.5 Filling balls into bearing without filling slot – Conrad Method [Eschmann]

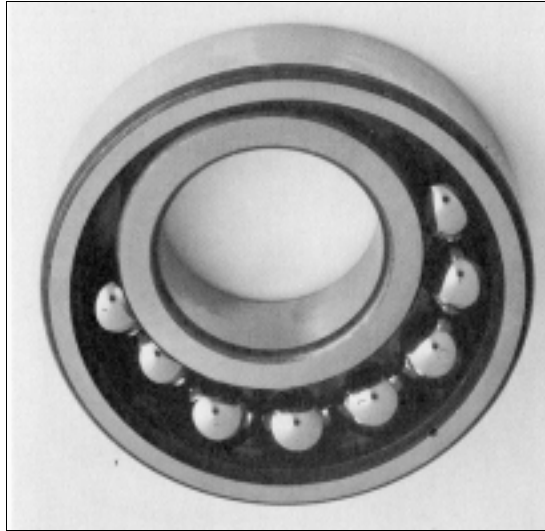

Figure 1.6 Photograph showing Conrad-type bearing components just prior to snapping the inner ring to the position concentric with the outer ring [Harris].

1.4 Torrington 5203 Double Row Ball Bearing

This thesis attempts to present a general approach for creating an optimal assembly process for double row ball bearings. However, the Torrington 5203 double row ball bearing will be used as an application example. The Torrington double row ball bearing is currently being assembled in Calhoun, Georgia. By the end of 1998, it will be manufactured in Pulaski, Tennessee. For Torrington, this bearing is a medium to high volume product and serves such clients as John Deere and other farm machine applications.

Double row ball bearings have the same four general components as all typical single-row bearings, namely, an inner ring, and outer ring, rolling elements, which in this case are balls and a cage or retainer to keep the balls separated. Due to its use in agricultural machinery the bearing is grease packed and double sealed to prevent the intrusion of foreign matter during operation. The Torrington 5203 bearing contains an additional component, a rubber O-ring and its seating groove, used solely for bearing assembly. The main components of the 5203 bearing, excluding seals and retainers are illustrated in Figure 1.7.



Bearing Inner Ring

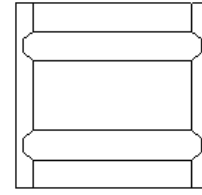

Bearing Outer Ring

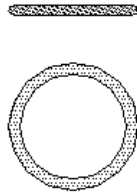

Ball support ring



Ball Bearings

Figure 1.7 Major components of the 5203 Double Row Ball bearing

1.4.1 Assembly Station Components

The Torrington 5203 double row ball bearing is assembled on a station designed specifically for that purpose. The majority of the process is accomplished manually with pneumatic assistance for bearing restraint and outer ring distortion. The assembly station sits atop a workbench, which is illustrated in Figure 1.8. The pneumatic cylinders and lever arms used to distort the outer ring of the bearing are located underneath the workbench and can also be seen in Figure 1.8. Figures 1.9a and 1.9b illustrate the individual components of the workstation.

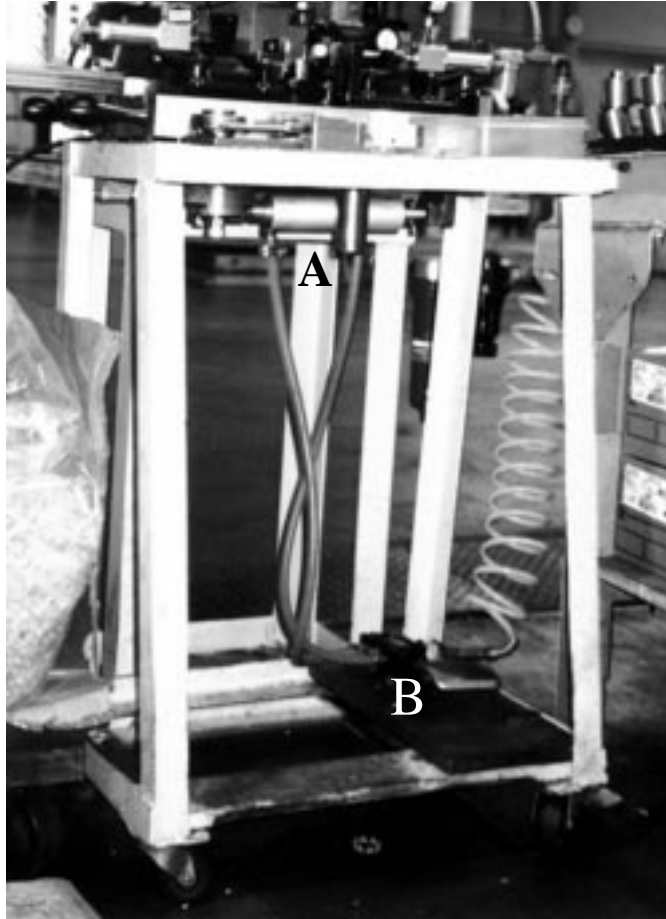

Figure 1.8 Assembly workbench with workstation, notice pneumatic cylinders underneath for distortion of bearing outer ring.

Assembly station and bench components:

- A. Large pneumatic cylinder for outer ring deformation
- B. Foot pedal for pneumatic system control
- C. Cam for outer ring deformation, radial displacement
- D. Spring-actuated plunger for center ring support
- E. Bearing support plate with lower ball support edge
- F. Bearing deformation anvil
- G. Bearing deformation chuck

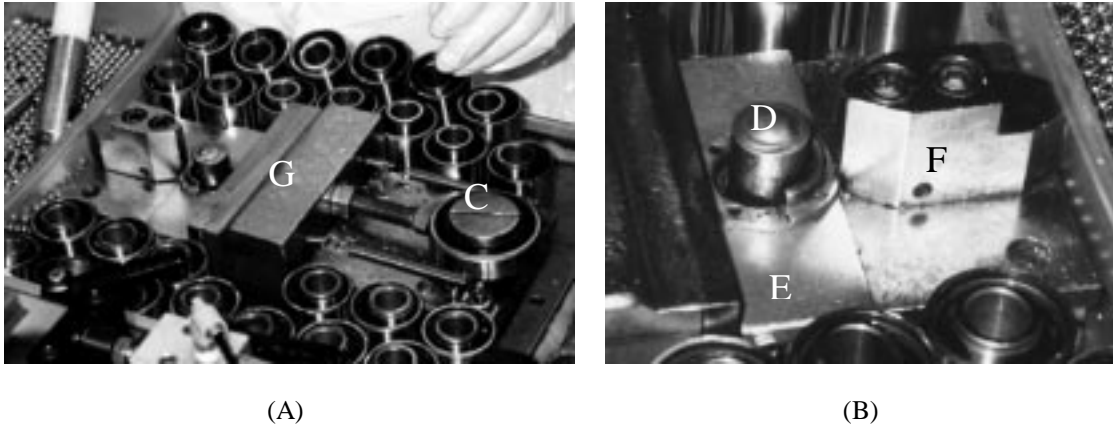

Figure 1.9 Figure (A) shows the full assembly station with larger square deformation chuck and anvil. The bearing sits on bearing support plate and its inner ring supported by a spring-actuated plunger, Figure (B).

1.4.2 5203 Double Row Ball Bearing Assembly Procedure

The 5203 double row ball bearings is assembled using a modified Conrad assembly method. As mentioned in the description of the general Conrad assembly method, the outer race of the bearing is distorted. This distortion allows clearance for the balls to fall into the lower race. The inner ring is initially tilted and supported by a spring-loaded plunger to a height such that the lower race of the inner ring is nearly aligned with the upper race of the outer ring. The first (lower) eight balls inserted rest along the lower race of the inner ring and the upper race of the outer ring (Figure 1.10a). The inner race is then depressed so that the lower races, inner and outer are aligned (Figure 1.10b). A support edge prevents the lower balls from falling completely out of the bearing during the assembly (Figure 1.10). A tilting post, best illustrated in Figure 1.11d and e, used to maintain the inner race in its tilted position has a flat edge on its opposite end that is used to verify that the balls are properly seated into the lower race. With the inner ring again tilted, allowance is made for the upper race to be filled with eight balls. This step can only be accomplished with the aid of a rubber O-ring around the inner ring just below the upper race, seated in a machined groove (Figure 1.10). Without the O-ring, the tilted inner ring permits sufficient clearance for the inserted balls to pass through to the lower race of the bearing. With the balls resting on the O-ring they are aligned with the upper race of both rings (Figure 1.10c). Once all eight balls are

properly seated in the race, the inner ring is positioned upright and concentric with the outer race, which snaps all balls into the upper and lower races (Figure 1.10d). The assembled bearing is removed from the pneumatic device that originally distorted the outer ring and should spin freely with little effort, thus verifying proper assembly.

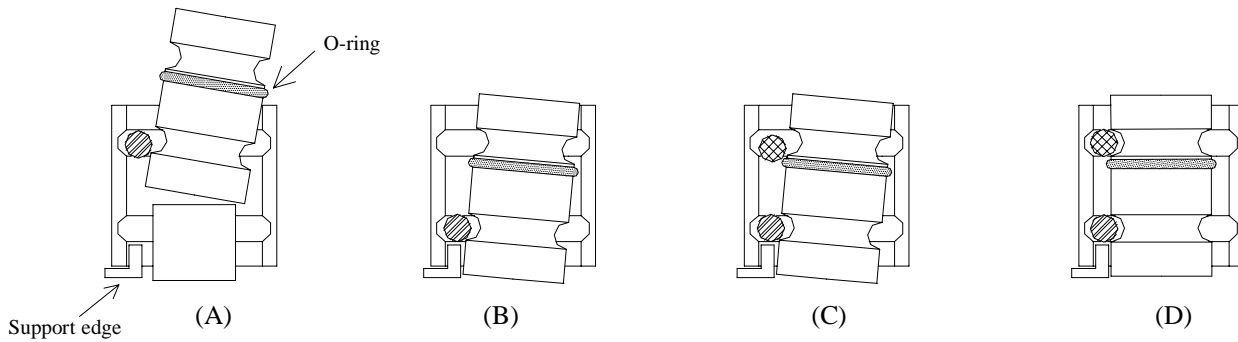





Figure 1.10A-D Illustrations of double row ball bearing assembly process, modified Conrad method

1.4.3 Problems with Current Assembly Procedure

This thesis seeks to improve upon an assembly process that has many problems. The assembly steps are simplified in Figure 1.10a-d. Although they appear simple in concept, they can become arduous when executed as a manual assembly process. As a manual process, human factors complicate the difficulties of assembly. The physical design of the bearing may also effect the assembly efficiency. All the assembly steps of the Torrington 5203 double row ball bearing have problems that need to be addressed. A few are illustrated here in attempt to show the general difficulty of the double row bearing process and to put in perspective the problem solution addressed in this thesis.

Photographs of Main Assembly Steps (Torrington 5203 double-row bearing)	Step Description	Problems with Assembly Step
 <p style="text-align: center;">(A)</p>	<p>Bearing inner ring supported by spring actuated plunger, lower eight balls inserted using filling sleeve.</p>	<p>Inner ring must be maintained at tilted angle for ball clearance.</p>
 <p style="text-align: center;">(B)</p>	<p>Inner ring depressed to align balls in lower races. A hand tool is used to verify that balls are properly seated.</p>	<p>Force must be maintained with thumb until balls are seated properly. Balls often fail to seat properly without significant operator effort.</p>
 <p style="text-align: center;">(C)</p>	<p>Collecting balls with hand tool to anvil side of bearing to allow sufficient tilting of inner ring and insertion of next eight balls.</p>	<p>Tedious task due to visual and spatial clearance. If not done properly, the next assembly procedure can not be accomplished.</p>



 <p>(D)</p>	<p>Balls have been snapped into lower race, inner ring again tilted using tilting hand tool to allow clearance for top eight balls.</p>	<p>Tilting force needed to maintain clearance for insertion of balls.</p>
 <p>(E)</p>	<p>With inner ring tilted, upper eight balls can be inserted, proper seating check with hand tool.</p>	<p>Tilting force continuously needed to allow entrance of balls, balls only retained at upper race due to rubber O-ring and seating groove.</p>

Figure 1.11A-E Illustration of the a few major assembly step for Torrington’s 5203 double row bearing.

Not only do the problems within the assembly steps make the process difficult they have the potential to cause ergonomic problems. Such problems are the result of repetitive motion and awkward positioning of the hands and arms, often known as Repetitive Motion Syndrome, Occupational Overuse Syndrome or Repetitive Strain Injuries (RSI). General causes of RSI, all of which can be seen in this assembly process, include repetitive tasks, awkward or fixed posture, forced movements, and insufficient rest time. Common RSI include Tendinitis, Tenosynovitis, Ganglionic Cysts and Carpal Tunnel Syndrome (CTS). According to the MIT web page, <http://web.mit.edu/is/pubs/is-13/rsi.html>, these RSI are described as follows:

Tendinitis - the inflammation of tendons that occur when muscles and tendons are repeatedly tensed. Symptoms may include pain and swelling. Eventually, the tendon becomes bumpy and fibers may fray. Or the tendons may thicken, making movement of the fingers, hands or arms difficult. Without sufficient time to heal, the tendon may be permanently weakened.

Tenosynovitis – the inflammation of the synovial sheath (tubes in which tendons glide back and forth) caused by repetitive motion. It usually occurs in the hands and wrists. This injury can be quite painful and tendon movement may become restricted due to the swelling of the sheath. If the sheath or tendon becomes scarred, tenosynovitis can cause permanent damage.

Ganglionic Cysts – another tendon sheath condition. The sheath swells up with synovial fluid and causes a bump under the skin, often on the wrist. Ganglionic cysts may be symptoms of tenosynovitis.

Carpal Tunnel Syndrome (CTS) – the most potentially disabling RSI. Nine tendons for flexing the fingers, along with the median nerve, pass from the forearm to the hand through a passage in the wrist called the carpal tunnel. The tunnel is made up of bone and ligament. CTS results when the median nerve is compressed, either from the swelling of tendons and sheaths or from repeated bending of the wrist. Symptoms include numbness, tingling, and pain in the side of the hand that goes from the thumb to the inside of the ring finger. Often the pain is worse when sleeping. Advance symptoms include weakness, especially in the thumb muscle, and clumsiness in the hands.

1.5 Secondary Problem Focus: Tilting Force

The main problems that exist in the current assembly process, aside from the ball support device, are the forces required to assemble the bearing. In particular, the tilting force has the potential to cause the ergonomic problems and substantially effect the assembly process. While a detailed study of this force is beyond the scope of this thesis a foundation for its study can be established through a simple experimental procedure. The goal is to determine how the resisting force is applied (i.e., which elements are in contact) and the magnitude of the force.

1.5.1 Force Measurement Setup and Assumptions

The force measurements were made by applying a known force to tilt the inner ring of a partially assembled bearing and measuring displacement. This setup was intended to answer two questions: 1) about what point (balls) is the inner ring tilting and 2) what can be said about the resisting force within the bearing during assembly. A load

was applied to a steel post inserted into the inner ring of the bearing as illustrated in Figure 1.12. Displacements were measured at point labeled X(top) and X(bottom).

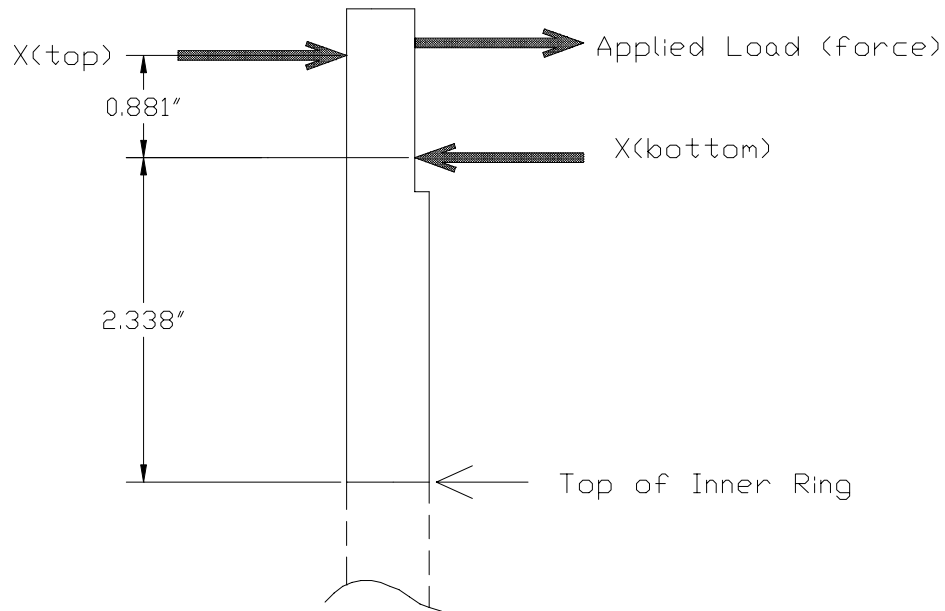

Figure 1.12 Experimental setup for applying a tilting force to the inner ring of the bearing assembly.

1.5.2 Force Measurement Results

The results of the force test data are listed in Table 1.1. The first x values indicate the initial position of the tilting post before any load was applied. Figure 1.13 is a plot showing force versus displacement. It illustrates a nearly linear relationship between the two. Line functions were formed from the measured displacement data and plotted against each other to determine the pivot point of the inner ring rotation. Prior to testing it was unclear whether the inner ring pivoted about a constant point or shifted between different balls. As illustrated in figure 1.14, the inner ring pivots about one point.

Table 1.1 Force Test Data

Measured Disp.(in)		Delta x		Forces		
x top	x bottom	x top	x bottom	added force(oz)	total force(oz)	total force(lb)
0.800	0.100	-	-	-	-	-
0.793	0.105	0.007	0.005	7.335	7.335	0.458
0.783	0.112	0.017	0.012	7.335	14.670	0.917
0.775	0.119	0.025	0.019	7.350	22.020	1.376
0.760	0.130	0.040	0.030	14.685	36.705	2.294
0.743	0.142	0.057	0.042	14.705	51.410	3.213
0.727	0.153	0.073	0.053	15.215	66.625	4.164
0.696	0.177	0.104	0.077	24.780	91.405	5.713
0.661	0.203	0.139	0.103	26.650	118.055	7.378
0.631	0.223	0.169	0.123	22.765	140.820	8.801

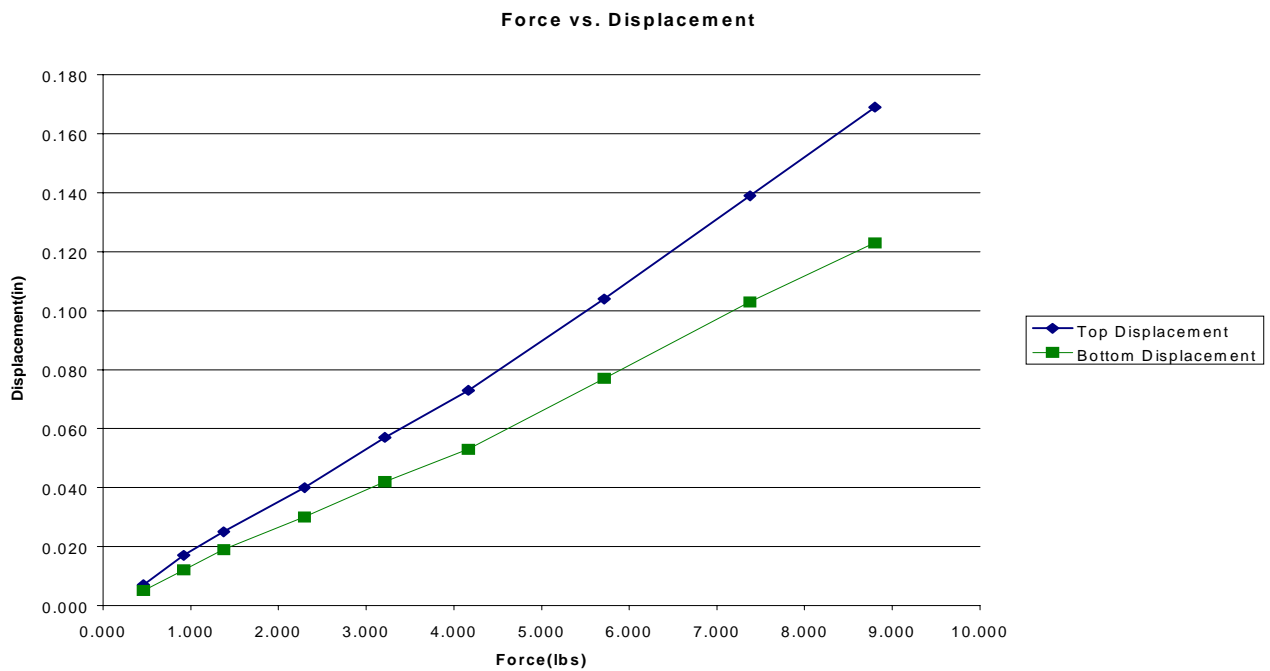

Figure 1.13 Force versus displacement of bearing inner ring tilt.

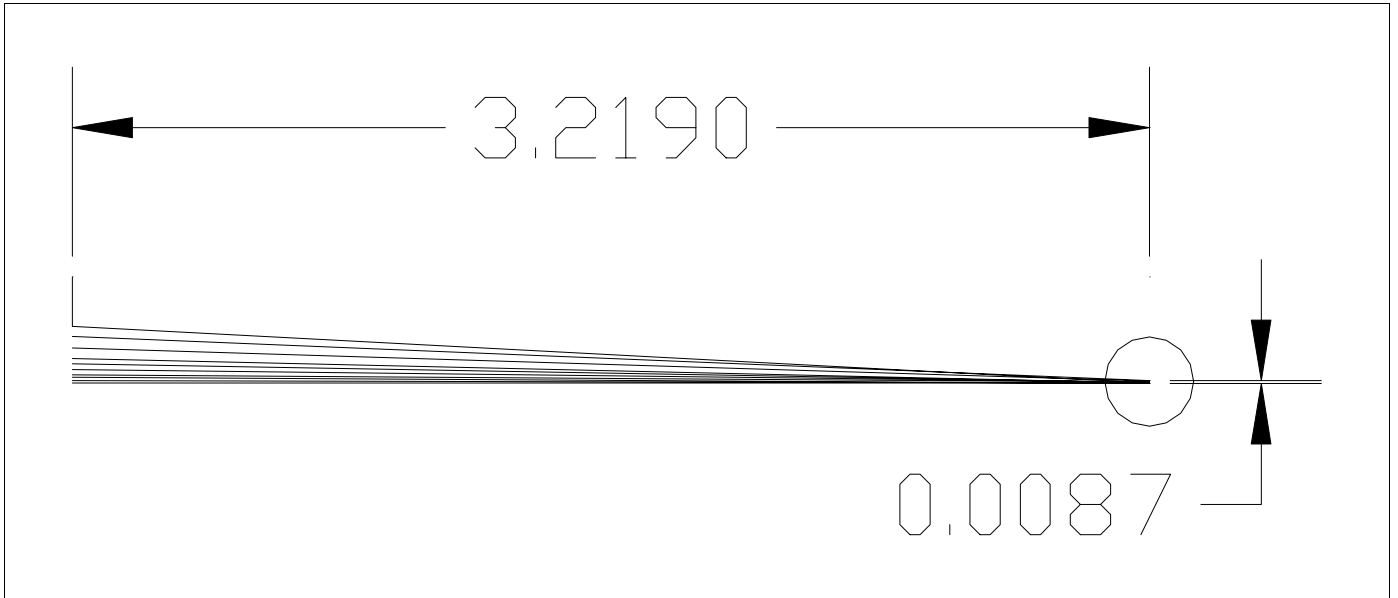

Figure 1.14 Displacement line plot to illustrate inner ring tilting (pivot) point.

These force measurements produce several valuable results. It can be observed that a substantial force is required to tilt the inner ring during the bearing assembly, nearly 9lbs. Repeated application of this force has the potential to cause ergonomic problems for the bearing assembler. It is also demonstrated that the pivot point for the inner ring of the bearing during assembly is stationary and occurs on balls 1 and 8 of the lower eight ball, see figure 1.15.

This initial investigation into the applied force on the bearing during assembly, specifically the tilting force, serves as a foundation and direction for future analysis. Such analysis may be necessary for further assembly modifications or reevaluation of the bearing design. The ideal assembly condition, if maintained as a manual process, would be the elimination of this tilting force.

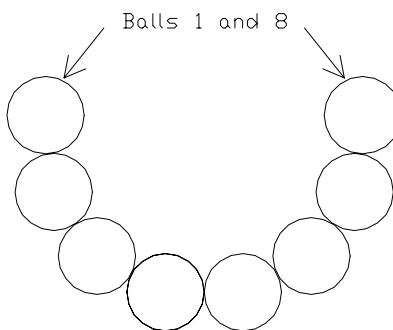

Figure 1.15 Pivot point about lower balls 1 and 8.

1.6 Existing Assembly Alternatives

Double row ball bearing assembly is a unique task in the bearing industry. It is such a unique process that little information is disclosed about existing assembly methods. Researches into other bearing manufacturer's assembly methods for double row bearings only showed that both Conrad and filling slot techniques are currently used. Other techniques include the use of two inner rings with a single outer ring as well as Conrad method with special tools for bearing assembly, very similar to the challenge of this thesis. Thus, the goal of this thesis not only serves as a useful solution to Torrington's double row ball bearing assembly but also may provide a foundation for further optimization of double row bearing assembly techniques in general.