

**THE EFFECTS OF PRIMING ON VIGOR AND VIABILITY OF
BROCCOLI (*Brassica oleracea* var. *italica* Plenck) SEEDS**

by

Lewis W. Jett

**Dissertation submitted to the Faculty of the Virginia Polytechnic
Institute and State University in partial fulfillment of the
requirements for the degree of
Doctor of Philosophy
in
Horticulture**

APPROVED:



Ronald D. Morse

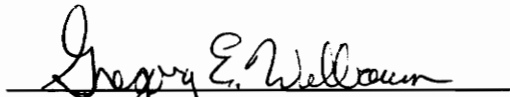

Gregory E. Welbaum

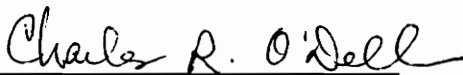

Charles R. O'Dell

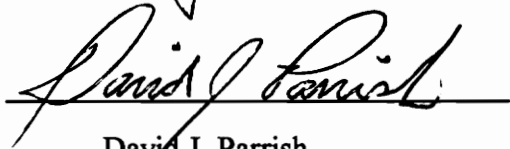

David J. Parrish

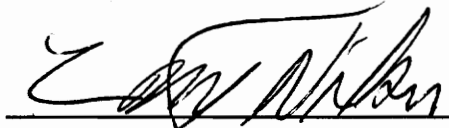

Erik Nilsen

December 15, 1994

Blacksburg, VA

C.2

LD
5655
V856
1994
J488
C.2

The Effects of Priming on Vigor and Viability of Broccoli (*Brassica oleracea* var. *italica* Plenck) Seeds

by

Lewis W. Jett

Gregory E. Welbaum, Chairman

Horticulture

(ABSTRACT)

Seed priming is a controlled hydration process, followed by dehydration, that allows pregerminative metabolic activity to proceed without germination. The objective of this research was to investigate the effects of priming on intrinsic characteristics of seed germination including temperature, water, and development, in order to understand how priming affects the germination of broccoli (*Brassica oleracea* var. *italica* Plenck) seeds. Priming of broccoli seeds consistently improved germination and emergence rate in the laboratory and field and was related to the accumulation of a specific level of hydropriming units expressed in MPa·h. Priming reduced the sensitivity of seed germination to temperature and increased the temperature range of germination but did not lower the minimum temperature for germination. Primed seeds leaked less electrolytes at supraoptimal temperatures ($\geq 35^{\circ}\text{C}$) compared to nonprimed seeds. In the field, primed seeds produced a greater plant stand and yield under stressful emergence conditions. Under optimal conditions in the field for stand establishment, the advancement in emergence of primed seeds did not carry over to earlier, greater yields. Matric priming, using calcium silicate as the carrier in the ratio 1.0:0.8:1.8 (seed:carrier:water; by weight) for 7 d at 20°C , was superior to osmotic priming using polyethylene glycol (PEG 8000) at

-1.2 MPa in nearly all variables examined. This may be attributed to reduced respiration during priming of seeds in PEG or nutrient uptake by seeds in calcium silicate.

The testa was observed to be a barrier to broccoli seed germination. Priming-induced changes to the physical characteristics of broccoli seeds included increased volume (32%) and an irreversibly expanded, and weakened testa with some minute cracking near the area where the radicle emerges. Primed seeds germinated faster, in part by maintaining a lower hydrotime constant, and thus exhibited a greater progression towards germination per unit water potential at a constant temperature compared with nonprimed seeds. It was hypothesized that, since the testa threshold was reduced after priming by expansion and formation of free spaces, the reversibly expanded embryo of primed seeds does not become immediately appressed to the testa upon rehydration. Thus the yield threshold component controlling the rate of germination of primed seeds is lower by the amount of the testa threshold. The priming effect is more than just reducing the yield threshold as indicated by a significant invigoration of seeds with split testae. Despite the increased volume as a result of the formation of free spaces, primed broccoli seeds did not imbibe more water or have a greater turgor at full hydration. Priming did not lower the minimum water potential allowing germination, and primed seeds did not plateau in water uptake but, instead, moved immediately from imbibition to expansive growth. Priming improved the germination rate of broccoli seeds at all stages of maturity with the most significant effects at stages before attainment of maximum dry weight. Dry storage of broccoli seeds at harvestable maturity (≥ 56 days after pollination) did not improve germination, indicating a lack of postharvest dormancy.

He causeth the grass to grow for the cattle, and herb for the service of man: that he may bring forth food out of the earth;

Psalms 104:14

Acknowledgements

I would like to thank Drs. David J. Parrish and Erik Nilsen for agreeing to serve on my committee. I am thankful to Dr. Gregory Welbaum for his patience, respect, advice, and the willingness to give me independence in my research. Dr. Ronald Morse has always been a good friend and advisor from the first day I arrived at Saunders Hall. I have learned a lot through our lengthy hours of conversation. As a fellow strawberry grower and native West Virginian, Mr. Charlie O'Dell has earned my ineffable respect. If I have a fraction of Charlie's knowledge, I will have a successful career.

There are some people that have passed through Saunders Hall that stand out in my mind as unique. Mr. Tom Dyson was such a person. I would like to thank Tom for encouraging me as a Christian. I would also like to thank the members of Bible Baptist Temple in Stonewood, West Virginia for their unceasing prayers. Finally, I thank my entire family for their infinite love and support.

Dedication

To my parents William and Pauline Jett. I could not have completed this phase of my education without their constant prayers and support.

Table of Contents

Chapter 1. Introduction.	1
Chapter 2. Examination of Priming Treatments for Broccoli Seeds.	
Abstract.	21
Introduction.	22
Materials and Methods.	23
Results and Discussion.	26
Chapter 3. Laboratory and Field Performance of Primed and Nonprimed Broccoli Seeds.	
Abstract.	41
Introduction.	42
Materials and Methods.	44
Results and Discussion.	48
Chapter 4. The Effects of Seed Priming on Physical Characteristics of Broccoli Seeds.	
Abstract.	69
Introduction.	70
Materials and Methods.	74
Results and Discussion.	79
Summary.	93
Chapter 5. Water Relations of Primed Broccoli Seeds.	
Abstract.	98
Introduction.	99
Materials and Methods.	100
Results and Discussion.	103
Chapter 6. Effects of Priming on Developing Broccoli Seeds.	
Abstract.	117
Introduction.	117
Materials and Methods.	119
Results and Discussion.	121
Chapter 7. Effects of Seed Size and Position Within the Silique on Germination and Vigor of Broccoli.	
Abstract.	133
Introduction.	133
Materials and Methods.	135
Results and Discussion.	137
Chapter 8. The Effects of Priming on Storage and Repair of Broccoli Seeds.	
Abstract.	144
Introduction.	144
Materials and Methods.	146
Results and Discussion.	148
Chapter 9. Summary	158

Appendix

161

Vita

170

List of Tables

Table 2.1. Characteristics of carriers used to prime broccoli seeds.	27
Table 2.2. Percent moisture content (dw. basis) of seeds and carriers used to prime broccoli seeds.	30
Table 2.3. Respiration rate, germination rate, and final germination percentage of matric-primed and osmotic-primed broccoli seeds.	33
Table 2.4. Determination of an effective Ψ for priming broccoli seeds.	38
Table 2.5. Laboratory and field evaluation of liquid and solid used to prime broccoli seeds	39
Table 3.1. Liquid and solid carriers used, ratios of seed:carrier:water (by weight), moisture content of seeds and carriers, and the measured Ψ of the seeds.	49
Table 3.2. Summary of field and lab. performance of matric- and osmotic-primed broccoli seeds.	51
Table 3.3. Seed germination and root growth characteristics of broccoli in response to priming.	54
Table 3.4. Sequential harvest of primed and nonprimed broccoli seedlings in a greenhouse.	58
Table 3.5. Emergence of primed and nonprimed broccoli seeds in crusted soils.	61
Table 3.6. Field evaluation of matric- and osmotic- primed broccoli seeds.	63
Table 3.7. Harvest variables of matric- and osmotic- primed broccoli seeds.	64
Table 4.1. Observations of germination behavior of primed and nonprimed broccoli seeds.	81
Table 4.2. Characteristics of broccoli seeds before and after priming.	84
Table 4.3. Base water potential, hydrotime constant, and yield threshold of primed and nonprimed broccoli seeds.	89
Table 5.1. Change in water relations in response to priming of broccoli seed.	111
Table 6.1. Effects of developmental age, drying, and priming on vigor and viability of broccoli seeds.	125
Table 7.1. Effect of seed position within the silique on germination of broccoli seeds.	138
Table 7.2. Effects of seed size and priming on germination of broccoli seeds.	139
Table 7.3. Seedling evaluation of large and small broccoli seeds at 32°C.	141

Table 8.1. Effects of osmotic priming broccoli seeds and long-term storage.	149
Table 8.2. The effects of accelerated aging at 45°C for 48 h on primed broccoli seeds	152
Table 8.3. Mean time to germination of split seeds as a function of temperature.	153
Table 8.4. Effect of seed coat splitting on MTG and percentage germination.	154
Table A.1. Percent germination of broccoli seeds primed in two molar (M) concentrations of KNO ₃ .	162
Table A.2. Micro and macro nutrient content of calcium silicate (Micro-Cel E) used to matric prime broccoli seeds.	163
Table A.3. Emergence of matric-primed and osmotic-primed broccoli seeds in the greenhouse.	164
Table A.4. Summary of harvest data using cv. 'Earlidawn' in southern VA (1990).	165

List of Figures

Figure 2.1. Moisture release curve for calcium silicate (Micro-Cel E) (A) and vermiculite (B).	28
Figure 2.2. Cumulative germination of nonprimed broccoli seeds over time (A), and as a function of water potential (Ψ) (B).	31
Figure 2.3. Mean germination rate of matric-primed (1.0:0.8:1.8) and osmotic-primed broccoli seeds for varying durations.	41
Figure 3.1. Germination percent (A), germination rate (B), and root length (C), of matric-primed, osmotic primed, and nonprimed broccoli seeds as a function of temperature.	52
Figure 3.2. Electrolyte leakage of primed and nonprimed broccoli seeds at 35 and 38°C.	56
Figure 3.3. Relative growth rate of shoots and roots of matric-primed, osmotic-primed, and nonprimed seedlings in the greenhouse.	59
Figure 4.1. Schematic of mature <i>Brassica</i> spp. seed.	73
Figure 4.2. The Instron Universal Testing Machine.	78
Figure 4.3. Chronology of broccoli seed germination.	80
Figure 4.4. External and internal changes of broccoli seeds after priming.	82
Figure 4.5. Environmental scanning electron micrograph of the testa of nonprimed (A) and primed (B) broccoli seeds.	85
Figure 4.6. Imbibition time course for intact and decoated, primed and nonprimed broccoli	86
Figure 4.7. Cumulative germination versus water potential for primed and nonprimed, intact and decoated broccoli	84
Figure 4.8. Mean germination rate versus water potential.	85
Figure 4.9. Representative Instron load-deflection curve.	91
Figure 4.10. Penetration force (N) required to puncture the testae of primed and nonprimed broccoli seeds.	94
Figure 5.1. A characteristic water potential isotherm.	104
Figure 5.2 Imbibition time course of primed and nonprimed broccoli seeds at 25°C.	105

Figure 5.3. Germination rate as a function of hydropriming time (MPa·h) at Ψ s ranging from -2.5 MPa to -1.0 MPa and at a fixed duration of priming (t_p).	107
Figure 5.4. Relationship between germination rate and percent moisture content of seeds after priming in Ψ s of -2.5 to -1.0 MPa.	109
Figure 5.5. Representative Ψ isotherms of nonprimed (A), and primed (B) broccoli seeds.	112
Figure 6.1. Dry and fresh weight changes of broccoli seeds and hulls (empty siliques).	122
Figure 6.2. Relative growth rate of siliques and seeds.	124
Figure 6.3. Effects of drying and priming on the germination of developing broccoli seeds.	126
Figure 8.1. Radicle length, hypocotyl length, and percentage of abnormal seedlings of primed and nonprimed broccoli seedlings from split seeds.	155
Figure A.1. Bulk modulus of elasticity (ϵ) of nonprimed broccoli seeds.	166
Figure A.2. Representative water potential isotherm for matric-primed broccoli seeds.	167
Figure A.3. Representative water potential isotherm for water-imbibed broccoli seeds (6h, 20°C).	168
Figure A.4. Characteristic severe splitting of broccoli seeds (cv. 'Arcadia').	169

Abbreviations Used

T_b	base temperature
Ψ_b	base water potential
°C	degree celsius
cm	centimeter
d	day
DAP	days after pollination
DAS	days after seeding
dw	dry weight
ESEM	Environmental Scanning Electron Microscopy
g	gram
≥	greater than or equal to
ha	hectare
h	hour
θ_H	hydroporosity constant
θ_T	thermal time constant
kg	kilogram
≤	less than or equal to
l	liter
LSD	least significant difference
m	meter
MGR	mean germination rate
min	minute
mm	millimeter
μmol	micromoles
M	molar
MPa	megapascal
MTG	mean time to germination
MTH	mean time to harvest
N	newton
Ψ_π	osmotic potential
RGR	relative growth rate
RWC	relative water content
T	temperature
T₅₀	MTG or time to 50% germination
t	metric ton
Ψ_p	turgor pressure
Y_t	testa yield threshold
Ψ₅₀	water potential that inhibits germination 50%
Ψ	water potential

Chapter 1

Introduction

The critical first step in successful production of vegetable crops is establishment of a suitable plant stand. Uniformity and emergence percentage of direct-seeded crops has a major impact on final yield and quality of vegetable crops (Wurr and Fellows, 1983).

Stand failures result from stresses in the seedbed such as temperature extremes, excess or deficit of water, salinity, and soil crusting combined with biological stresses such as pathogen and insect attack. Often, these stresses interact in a negative way to adversely affect germination and seedling growth (Bradford, 1986).

In the southeastern United States, fresh market bunching broccoli (*Brassica oleracea* var. *italica* Plenck) is routinely field established by direct-seeding. In bunching broccoli production, several heads are bunched together to make a single marketable unit. Because relatively high plant densities are required for profitable production of bunching broccoli, direct seeding is normally practiced to minimize plant establishment costs (Jett et al., 1995). In the relatively hot, humid climates of Virginia, production of fall bunching broccoli requires seeding during stressful summer climatic and edaphic conditions that routinely reduce seedling emergence and yield (Elson et al., 1992; Jett and Welbaum, 1992).

Seed vigor is defined as those properties which determine the potential for rapid, uniform emergence and development of normal seedlings under a wide range of field conditions (AOSA, 1983). Thus, a pre-sowing treatment for broccoli seeds that would enhance seed performance by improving seed vigor could possibly translate into improved stand establishment of fall bunching broccoli in the southeastern United States. Crops harvested during vegetative growth (e.g. lettuce, cabbage, etc.) are harvested on an individual-plant or area basis as vegetative mass. The effects of seed vigor on emergence

and stands can be very critical in these crops, where delayed emergence or missing plants reduce yield and plant uniformity at harvest (Tekrony and Egli, 1991). The correlation of area yield and seed vigor is low with crops in which the fruit is harvested (e.g. tomato) (Tekrony and Egli, 1991). Since broccoli is harvested between a vegetative and reproductive stage, the effects of seed vigor may be important in improving yield.

A pre-sowing technique that can be used to improve seed vigor is termed priming or conditioning. The term "priming" was coined by Malanassy (1971) and reported by Heydecker (1974) to describe a treatment to improve germination at low temperatures. The term specifically indicates a controlled hydration technique that brings seeds to a water content which permits pre-germinative metabolic activity to proceed but prevents radicle emergence (Heydecker and Coolbear, 1977). Seed priming allows the seed to achieve many of the biochemical and physiological changes associated with germination without expansive growth. Primed seeds can be dried, and, upon subsequent rehydration, consistently exhibit a more rapid onset of germination, more uniform emergence, better plant stands, and sometimes increased yields.

Two distinct techniques may be used to prime seeds. When seeds are hydrated in low water potential (Ψ) osmotica, the technique is called osmotic priming or conditioning. A number of osmotica, including polyethylene glycol (PEG), KNO_3 , K_3PO_4 , KH_2PO_4 , MgSO_4 , NaCl , glycerol, and mannitol have been used to osmotically prime seeds of many plant species (Ells, 1963; Powell and Matthews, 1978; Bodsworth and Bewley, 1981). Polyethylene glycol is the most frequently used solute for osmotic priming. PEG with a molecular weight greater than 8000 is excluded from plant cell walls and cannot be taken up by the seed (Tarkow et al., 1966; Carpita et al., 1979). Generally, osmotic priming requires 2 to 21 days (depending on the species), a Ψ of the osmoticum ranging from -0.8 to -1.6 MPa, and a temperature maintained at 15 to 20°C (Khan, 1992).

Osmotic priming has proven to be a very effective pre-sowing seed treatment for a number of species including asparagus (Owen and Pill, 1994); carrot (Szafirowska et al., 1981; Brocklehurst and Dearman 1983b; Haigh et al., 1986), beet (Khan et al., 1980), sugarbeet (Durrant et al., 1983), celery (Rennick and Tiernan 1978), parsley (Heydecker and Coolbear, 1977; Pill, 1986; Rabin et al., 1988), parsnip (Gray et al., 1984), leek (Brocklehurst et al., 1984; Dearman et al., 1987), onion (Brocklehurst and Dearman, 1983b, 1984; Haigh et al., 1986), pepper (Rivas et al., 1984), tomato (Wolfe and Sims 1982; Haigh et al., 1986; Alvarado et al., 1987; Barlow and Haigh 1987; Argerich et al., 1990; Owen and Pill, 1994), Brussels sprouts (Khan et al., 1980), cabbage (Khan et al., 1981), kale (Rao et al., 1987), turnip (Rao et al., 1987), lettuce (Cantliffe et al., 1981; Valdes et al., 1985), spinach (Atherton and Farooque, 1983), muskmelon (Bradford et al., 1988), and watermelon (Sachs, 1977). However, seeds of certain species have not responded positively to osmotic priming. Germination and emergence of large seeded species such as sweet corn and soybean seeds have not been improved with osmotic priming (Bennett and Waters, 1987; Khan, 1992).

Another priming technique is referred to as matric priming or conditioning. A matric seed priming effect was first demonstrated by Wallace (1960), who observed that germination could be stimulated by pre-equilibration in unsaturated soil. Matric priming employs the matric properties of solid carrier materials to control the hydration status of the seed. The carrier and added water create a "matrix" for seed priming, and the matric water potential is derived from adsorptive, interfacial tension, attraction and adhesion between carrier matrix, matrix-air and matrix-water (Hadas, 1981). A carrier material that is suitable for matric priming should have the following characteristics: 1) a high matric potential; 2) negligible water solubility; 3) low chemical reactivity; 4) high water holding capacity; 5) high flowability, capacity to remain a dry, free flowing powder; 6) variable

particle size, structure and porosity; 7) high surface area; 8) high bulk value and low bulk density, providing results at very low levels of addition; and 9) the ability to adhere to the seed surface (Khan, 1992). Some of the materials that can be commonly used as solid carrier for matrix priming include the various grades of Celite (diatomaceous silica), vermiculite, and calcium silicate (Micro-Cel E). Micro-Cel E is produced by a hydrothermal reaction of diatomaceous silica, hydrated lime and water. Matrix priming using calcium silicate and vermiculite (horticultural grade no. 2) as carriers has been successfully used to prime red beets, sugarbeets, onions, tomatoes, pepper, carrot, celery, lettuce, snap beans, and soybean seeds (Khan, 1992). When compared with osmotic priming using polyethylene glycol (PEG), matrix priming consistently results in a significantly greater seed vigor (Khan, 1992).

As a result of the disadvantages associated with using liquid solutions to prime seeds, research has focused on developing more effective seed priming treatments. Seeds, such as broccoli, that lack heterogeneous or protective tissue surrounding the embryo are not able to be primed in salt solutions, and therefore polyethylene glycol (PEG) is routinely used as the priming agent. Polyethylene glycol, however possesses negative characteristics such as low oxygen solubility and high viscosity, which reduce its performance as a seed priming agent. Moreover, PEG has been reported to be toxic to some seed species (Mobayen and Milthorpe, 1978).

An obstacle to commercial application of seed priming in general is the variability of results observed among species, cultivars, and seed lots (Heydecker, 1974). Ultimately, the most effective seed priming treatment will be determined through better understanding of how seed priming enhances subsequent germination. More information is needed about the physiology of primed seeds. The paucity of information indicates that the effects of priming differ with individual seed species. Therefore, specific priming conditions must be

developed by trial and error for each species (Bradford, 1986). Akers and Holley (1986) outlined a screening procedure for osmotic priming of carrot, pepper, celery, parsley, broccoli, tomato, and lettuce seeds. However, no research has been conducted to develop a similar procedure using matric priming. Moreover, there have been no studies to date comparing laboratory and field performance of osmotic and matric primed broccoli seeds. Plant stand establishment is the most difficult cultural practice for obtaining profitable fall broccoli yields in Virginia and the Southeast (Welbaum and O'Dell, 1990). Therefore, development of an effective seed priming treatment for broccoli seeds would be important for improving stand establishment of broccoli in the Southeast.

Germination enhancement of primed seeds has been hypothesized to be related to metabolic repair processes (Burgass and Powell, 1984; Bray et al., 1989), a build-up of germination metabolites (Khan et al., 1978), and osmotic adjustment during imbibition (Bradford, 1986). In addition to these attributes, it has been postulated that seed priming improves seed vigor by 1) decreasing electrolyte leakage with a concomitant reduction in growth of pathogenic organisms; 2) enhances mobilization of seed proteins, lipids and starch as a result of activation of key enzymes; and 3) increases the potential for oxidative phosphorylation and adenosine triphosphate accumulation (Pill, 1994). Priming treatments have been shown to advance developmental processes in some species such as celery and remove thermodormancy in lettuce (Heydecker and Coolbear, 1977; Wiebe and Tiessen, 1979; Perkins-Veazie and Cantliffe, 1984; Valdes and Bradford, 1987; van der Toorne, 1989). Welbaum and Bradford (1991) reported that the positive effects of priming are more noticeable with seeds of a younger developmental age, indicating that priming substitutes for an after-ripening requirement of muskmelon seeds. Physiological and biochemical changes occur during priming that allow seeds to develop a high germination potential (radical thrust) or the ability to remove the seed coat restraint (Khan, 1992).

Priming may decrease the sensitivity of germinating broccoli seeds to temperature. The thermal time model proposed by Garcia-Huidobro et al. (1982) can be used to explain how priming affects the germination of broccoli seeds at different constant temperatures. According to this model, the rate of germination is a function of the product of the difference between the imbibition temperature and the base temperature (T_b) (minimum temperature for germination) and the thermal time constant (θ_T) expressed in °h. Priming may either lower the T_b or decrease the θ_T (or both) of broccoli seeds.

Gummerson (1986) proposed a model for analyzing seed germination response to water potential (Ψ). Based on the thermal time model, the basic assumption was that the rate of germination is related to the minimum Ψ allowing germination of a particular percentage referred to as the base Ψ (Ψ_b) and the hydrotime constant (θ_H), expressed in MPa·h. The hydrotime constant is defined by the equation

$$\theta_H = (\Psi - \Psi_{b(g)})t_g$$

where Ψ is the water potential of the imbibition medium, $\Psi_{b(g)}$ is the base water potential of percentage g , and t_g is the time to radical emergence of percentage g (used in this dissertation as T_{50}). Therefore, priming may affect germination performance by altering (lowering) $\Psi_{b(g)}$ and (or) by maintaining a lower θ_H .

Mechanical barriers, such as the endosperm, persiperm, or seed coat tissues, limit radicle emergence in many types of seeds (Hegarty and Ross, 1978; Liptay and Schopfer, 1983; Watkins and Cantliffe, 1983; Groot and Karssen, 1987; and Bradford, 1990). Groot and Karssen (1987) reported that weakening of the endosperm is a normal prerequisite for germination of tomato seeds. Priming may act by weakening the integrity of covering tissue. Haigh (1988) found that the break strength of isolated tomato endosperm tissue decreased during priming, but that the restraining force exceeded the force that could be generated by the embryo. He proposed that a second weakening of the

endosperm occurred coincident with radical growth for germination to proceed. Dahal and Bradford (1990) discovered that priming of tomato seeds which have an embryo encased by endosperm, did not lower the minimum Ψ allowing germination. The base Ψ (Ψ_b) is the Ψ that inhibits germination by 50%. Removal of the endosperm seed coat cap, however, increased the germination rate at all Ψ s above the base water potential (Ψ_b).

Bradford (1990) proposed adapting the Lockhart model describing cell growth to the initiation of radical growth during germination. The Lockhart model describes cell growth by the empirical equation $dV/Vdt = m(\psi_p - Y)$ where dV/Vdt is the rate of volume increase relative to total volume, m is the extensibility coefficient relating growth to ψ_p (turgor pressure), and Y is the minimum or threshold turgor that must be exceeded for growth to occur. Rewritten in terms of the rate of germination (GR) at a constant temperature, it is $GR = 1/\theta_H(\Psi - \Psi_b)$, where θ_H is the hydrotime constant (MPa·h), Ψ is the water potential during imbibition, and Ψ_b is the base water potential or the minimum water potential for germination. Thus, priming can increase the rate of germination by decreasing θ_H or the Ψ_b . If a restraining tissue (e.g. endosperm, persisperm, or testa) affects germination, removing it will lower the Ψ_b .

The largest portion of the broccoli seed is the embryo. As the embryo develops, it fills the large vacuole of the embryo sac and absorbs the cytoplasmic contents of the sac as well as the endosperm. Surrounding the embryo is the testa, or seed coat, derived from the two integuments and nucellar tissue. The outer coat of the seed consists of an epidermis and two layers of subepidermal tissue which is derived from the outer integuments. The inner seed coat consists of two layers, a thick-walled supporting tissue one-cell thick and an irregular layer of pigmented cells originating in the inner integument (Thompson, 1933). Liou (1987), examining cabbage (*Brassica oleracea* L. var. *capitata*), reported that the faster rate of imbibition and radical growth observed with osmotically

primed seeds was believed to be related to a priming-modified change in external or internal factors such as the testa. However, Schopfer and Plachy (1987) reported that the testa of rape (*Brassica napus* L.) seeds split during imbibition and thus is not likely to be a barrier to germination. McCormac and Keefe (1990) observed that the intact testae of cauliflower (*Brassica oleracea* L.) seeds are capable of limiting the rate of water influx into the seed. Research with radish (*Raphanus sativus* L.), a related Brassicaceae member, revealed that the testa interacted additively with far red light to limit the germination potential of radish seeds (Schopfer and Plachy, 1993).

Although priming is based on controlling the water status of the seed, very little research has focused on the water relations of priming seeds. Most seeds exhibit a triphasic pattern of water uptake. The first phase is characterized by a rapid initial uptake of water into the dry seed followed by a plateau phase (lag phase) with little change in water content, and a subsequent increase in water coincident with radical growth (Bradford, 1990). Factors which promote germination, such as priming, do so by shortening the lag phase. Bradford (1986) reported that radical emergence is related to the attainment of a threshold seed water content rather than a specific Ψ . Seed germination rates were shown to be directly related to changes in turgor of the embryo. In seeds where tissue restrains expansion of the embryo, germination occurs when the embryo turgor exceeds the threshold for both the embryo and the restraining tissue (Bradford, 1990). Hegarty (1977) showed that seed water content increased with duration at Ψ 's greater than -2.2 MPa, while at lower Ψ 's it stayed essentially the same. Liou (1987) concluded that the beneficial effects of priming on the rate of germination and vigor of cabbage seeds was not mediated by changes in the basic water relations of the seeds. Osmotic priming for 14 days at -1.5 MPa PEG did not cause a change in the base

water potential (Ψ_b). Also, the Ψ and osmotic potential (ψ_π) of primed and nonprimed seeds at full hydration did not differ.

The flowers of *B. oleracea* are borne in racemes on the main stem and its axillary branches. Cross-pollination must be performed with other plants, since most plants are self-incompatible. Pollination in the field is accomplished primarily by insects, because the pollen is sticky and is not windblown. After fertilization, the endosperm develops rapidly, while embryo growth does not start for several days. The embryo fills most of the seed after approximately three to five weeks, as the endosperm is almost completely absorbed. Nutrient reserves for germination are stored in the cotyledons, which are folded together with the radicle lying between them (Dickson and Wallace, 1987).

The fruits of *Brassica* spp. are glabrous siliques, 4 to 5 mm wide and approximately 10 cm long, with two rows of seeds lying along the edges of the replum (false septum, an outgrowth of the placenta). A silique will contain approximately 10 to 30 seeds. Three to four weeks after the opening of its flower, the silique reaches its full length and diameter. When the fruit is ripe, the two valves of the silique will dehisce or "shatter." Separation begins at the attached base and works towards the unattached ends, leaving the seeds attached to the placentas (Dickson and Wallace, 1987).

Brassica spp. have an extended flowering period. At the time of harvest, seeds of different physiological age are harvested (Still and Bradford, 1994). The effects of developmental age on vigor is not known with *B. oleracea*. Moreover, certain *Brassica* spp. seeds exhibit postharvest dormancy. *Brassica oleracea* seeds exhibit a wide range of dormancy ranging from no dormancy to deep dormancy that may be prolonged or removed by dry storage, indicating a potential dry after-ripening requirement (Tokumasu, 1970). *Crambe* (*Crambe abyssinica* Hochst. ex. R. E. Fries), a cool-season annual member of the family Brassicaceae, possesses primary dormancy related to the physical

restrictions of the seed coat (Gutormson et al., 1993). One of the effects of priming may be to relieve postharvest dormancy by substituting for an after-ripening requirement.

Seed size is an often used criterion to classify the quality of seeds (Liou, 1987).

Tomato, pimento, and broccoli seeds have shown a positive correlation of seed size with seedling growth (Tomkins, 1966; Cochrane, 1974; Jacobsohn and Globerson, 1980). Also seedling stand, seedling dry weight, and final yield of broccoli in crusted soils have been increased as seed size increased (Heather and Sieczka, 1991). Little is known about how position of the developing seed within the silique affects its subsequent germination and vigor. Egli and Wood (1978) reported that position of soybean seeds within the pod significantly affected seed size but not the effective seed filling period. It is not known if the difference in seed size correlates with differences in vigor. If there is a significant difference in seed vigor between large and small seeds, priming could be of greater benefit to a seedlot of relatively smaller seeds compared to a seedlot with larger seeds.

A critical component of seed vigor is resistance to deterioration during storage. A reduction in storage life is characteristic of seed deterioration. Reports on the storage of primed seeds have been conflicting. Some researchers have found that the attributes of primed seeds were retained (Heydecker et al., 1974; Dearman et al., 1987; Haigh et al., 1986; Akers et al., 1987; Oluoch and Welbaum, 1994; Owen and Pill, 1994). On the other hand, a reduction in the storage life of primed seeds has also been reported (Alvarado and Bradford, 1988a; Nath et al., 1991; Odell and Cantliffe, 1986; Weges, 1987). Priming has been reported to repair damage during seed storage. Burgass and Powell (1984) and Liou (1987) observed that osmotic priming of Brussels sprouts (*Brassica oleracea* var. *gemmifera*) and cabbage (*Brassica oleracea* var. *capitata*) seeds, respectively, significantly improved seed vigor, with the most significant enhancement of low-vigor seedlots.

The overall objective of this research was to examine the effects of priming on broccoli seed vigor. This was performed in a logical, step-wise fashion by 1) developing the most effective (i.e. increased vigor) seed priming treatment for broccoli seeds; 2) testing performance of the most effective treatment under controlled conditions in the laboratory, greenhouse, and field over a three year period; 3) understanding how priming affects the physical properties of the seed; 4) understanding how priming affects the water relations of the seed; 5) determining how priming affects developmental seed vigor; 6) determining how priming affects germination performance of various seed sizes of broccoli; and 7) observing how primed seeds perform after storage.

Literature Cited

- Akers, S. W. and K. E. Holley. 1986. SPS: A system for priming seeds using aerated polyethylene glycol or salt solutions. *HortScience* 21:529-531.
- Akers, S. W., G. A. Berkowitz, and J. Rabin. 1987. Germination of parsley seed primed in aerated solutions of polyethylene glycol. *HortScience* 22:250-252.
- Alvarado, A. D., K. J. Bradford, and J. D. Hewitt. 1987. Osmotic priming of tomato seeds: effects on germination, field emergence, seedling growth, and fruit yield. *J. Amer. Soc. Hort. Sci.* 112:427-432.
- Alvarado, A. D. and K. J. Bradford. 1988. Priming and storage of tomato (*Lycopersicon lycopersicum*) seeds. 1. Effects of storage temperature on germination rate and viability. *Seed Sci. Technol.* 16:601-612.
- Anon., 1983. Seed vigor testing handbook. *Association of Official Seed Analysts*, Springfield, Illinois, USA.
- Argerich, C. A., K. J. Bradford, and F. M. Ashton. 1990. Influence of seed vigor and preplant herbicides on emergence, growth and yield of tomato. *HortScience* 25:288-291.
- Atherton, J. G. and A. M. Farooque. 1983. High temperature and germination in spinach *Spinacia oleracea*. 2. Effects of osmotic priming. *Scientia Hort.* 19:221-228.
- Barlow, E. W. R. and A. M. Haigh. 1987. Effect of seed priming on the emergence, growth and yield of UC82B tomatoes in the field. *Acta Hort.* 200:153-164.
- Bennett, M. A. and L. Waters, Jr. 1987. Seed hydration treatments for improved sweet corn germination and stand establishment. *J. Am. Soc. Hort. Sci.* 112:45-49.

- Bodsworth, S., and J. D. Bewley. 1981. Osmotic priming of seeds of crop species with polyethylene glycol as a means of enhancing early and synchronous germination in cool temperatures *Can. J. Bot.* 59:672-676.
- Bradford, K. J. 1986. Manipulation of seed water relations via osmotic priming to improve germination under stress conditions. *HortScience* 21:1105-1112.
- Bradford, K. J., D. M. May, B. J. Hoyle, Z. S. Skibinski, S. J. Scott, and K. B. Tyler. 1988. Seed and soil treatments to improve emergence of muskmelon from cold or crusted soils. *Crop Sci.* 28:1001-1005.
- Bradford, K. J. 1990. A water relations analysis of seed germination rates. *Plant Physiol.* 94:840-849.
- Bray, C. M., P. A. Davison, M. Ashraf, and R. M. Taylor. 1989. Biochemical changes during osmopriming of leek seeds. *Ann. Bot.*:185-193.
- Brocklehurst, P. A. and J. Dearman. 1983b. Interactions between seed priming treatments and 9 seed lots of carrot, celery, and onion: I. Laboratory germination. *Ann. Appl. Biol.* 102:585-593.
- Brocklehurst, P. A. 1984. A comparison of different chemicals for osmotic treatment of vegetable seed. *Ann. Appl. Biol.* 105:391-398.
- Burgass, R. W. and A. A. Powell. 1984. Evidence for repair processes in the invigoration of seeds by hydration. *Ann. Bot.* 53:753-757.
- Cantliffe, D. J., K. D. Schuler and A. C. Guedes. 1981. Overcoming seed dormancy in heat sensitive romaine lettuce by seed priming. *HortScience* 16:196-198.
- Carpita, N. C., M. W. Nabors, C. W. Ross and N. L. Petretic. 1979. The growth physics and water relations of red light-induced germination in lettuce seeds. IV. Biochemical changes in the embryonic axes of red- and far-red treated seeds. *Planta* 144:225-233.

- Cochran, H. L. 1974. Effect of seed size on uniformity of pimento transplants (*Capiscum annum* L.) at harvest time. *J. Amer. Soc. Hort. Sci.* 99:234-235.
- Dahal, P. and K. J. Bradford. 1990. Effects of priming and endosperm integrity on seed germination rates of tomato genotypes. II. Germination at reduced water potential. *J. Exp. Bot.* 41:1441-1453.
- Durrant, M. J., P. A. Payne, and J. M. Maclaren. 1983. The use of water and some inorganic salt solutions to advance sugar beet seed: II. Experiments under controlled and field conditions. *Ann. Appl. Biol.* 103:517-526.
- Dearman, J., P. A. Brocklehurst, and R. L. K. Drew. 1987. Effects of osmotic priming and ageing on the germination and emergence of carrot and leek seeds. *Ann. Appl. Biol.* 111:717-722.
- Dickson, M. H. and D. H. Wallace. 1987. Cabbage breeding. pp. 395-432. In: *Breeding Vegetable Crops* (Mark Bassett, ed.), AVI Publishing, Co., Inc. Westport, Conn.
- Egli, D. B. and J. M. Wood. 1978. Influence of soybean seed size and position on the rate and duration of filling. *Agron. J.* 70:127-130.
- Ells, J. E. 1963. The influence of treatments with nutrient solutions on emergence and seedling growth. *Proc. Amer. Soc. Hort. Sci.* 83:684-689.
- Elson, M. K., R. D. Morse, D. D. Wolfe, and D. H. Vaughn. 1992. High temperature inhibition of seed germination and seedling emergence of broccoli. *HortTechnol.* 2:417-419.
- Garcia-Huidobro, J., J. L. Monteith, and G. R. Squire. 1982. Time, temperature and germination of pearl millet (*Pennisetum typhoides* S. & H.). I. Constant temperature. *J. Exp. Bot.* 33:288-296.

- Gray, D., P. A. Brocklehurst, J. R. A. Steckel, and J. Dearman. 1984. Priming and pregermination of parsnip (*Pastinaca sativa* L.) seed. *J. Hort Sci.* 59:101-108.
- Groot, S. P. C. and C. M. Karssen, 1987. Gibberellins regulate seed germination in tomato by endosperm weakening: a study with gibberellin-deficient mutants. *Planta* 171:525-531.
- Gummerson, R. J. 1986. Effect of constant temperatures and osmotic potentials on the germination of sugar beet. *J. Exp. Bot.* 37:729-741.
- Gutormson, T. J., K. L. Larson, and T. Waqar. 1993. Germination of freshly-harvested and after-ripened crambe (*Crambe abyssinica* Hochst. Ex. R. E. Fries) seed. *J. Seed Technol.* 16:17-23.
- Hadas, A. 1981. Seed-soil contact and germination. p. 507-527. In: *The Physiology and Biochemistry of Seed Development, Dormancy and Germination*. (A. A. Khan, ed.), Elsevier, Amsterdam.
- Haigh, A. H., W. R. Barlow, F. L. Milthorpe, and P. J. Sinclair. 1986. Field emergence of tomato (*Lycopersicon esculentum*) carrot (*Daucus carota*) and onion (*Allium cepa*) seeds primed in an aerated salt solution. *J. Amer. Soc. Hort. Sci.* 111:660-665.
- Haigh, A. H. 1988. Why do tomato seeds prime? Physiological investigations into the control of tomato seed germination and priming. *Ph.D. Dissertation*, Macquarie University, Sydney, Australia. 121 pp.
- Heather, D. W. and J. B. Sieczka. 1991. Effect of seed size and cultivar on emergence and stand establishment of broccoli in crusted soils. *J. Amer. Soc. Hort. Sci.* 116:946-949.
- Hegarty, T. W. 1977. Seed activation and seed germination under moisture stress. *New Phytol.* 78:349-359.

- Hegarty, T. W. and H. A. Ross. 1978. Differential sensitivity to moisture stress of seed germination and seedling radicle growth. *Ann. Bot.* 42:1003-1005.
- Heydecker, W. and P. Coolbear. 1977. Seed treatments for improved performance-survey and attempted prognosis. *Seed Sci. Technol.* 5:353-425.
- Heydecker, W. 1974. Germination of an idea: The priming of seeds. *University of Nottingham School of Agriculture Report.* pp. 50-67.
- Jacobsohn, R. and D. Globerson. 1980. *Daucus carota* (carrot) seed quality: I. Effects of seed size on germination, emergence, and plant growth under subtropical conditions and, II. The importance of the primary umbel in carrot seed production. In: *Seed Production* (P. D. Hebblethwaite ed.), pp. 637-646. Bitterworths, London.
- Jett, L. W. and G. E. Welbaum. 1992. Osmotic and solid phase priming of broccoli seed. pp. 73-81. In: *Proceedings Natl. Symp. Stand Estab. Hortic. Crops*, Ft. Myers, Fla.
- Jett, L. W., R. D. Morse, and C. R. O'Dell. 1995. Plant density effects on the production of single-head broccoli. *HortScience* 30(2).
- Khan, A. A. 1978. Incorporation of bioactive chemicals into seeds to alleviate environmental stress. *Acta. Hort.* 83:225-234.
- Khan, A. A., N. H. Peck and C. Samimy. 1980. Seed osmoconditioning: physiological and biochemical changes. *Isr. J. Bot.* 29:133-144.
- Khan, A. A. 1992. Preplant physiological seed conditioning. *Hort. Rev.* 14:131-181.
- Liou, T. D. 1987. Studies on germination and vigour of cabbage seeds. *Ph.D Dissertation*, Wageningen, The Netherlands. 101 pp.
- Liptay, A., and P. Schopfer. 1983. Effect of water stress, seed coat restraint, and abscisic acid upon different germination capabilities of two tomato lines at low temperature. *Plant Physiol.* 73:935-938.

- Malanassy, T. G. 1971. Physiological and biochemical studies on a treatment hastening the germination of seeds at low temperature. *Ph.D. Dissertation*, Rutgers University, New Jersey.
- McCormack A. C. and P. D. Keefe. 1990. Cauliflower (*Brassica oleracea* L.) seed vigour: imbibition effects. *J. Exp. Bot.* 41:893-899.
- Mobayen, R. G. and F. L. Milthorpe. 1978. Citrus seed germination as influenced by water potential and salinity. *Proc. Intl. Soc. Citriculture* 1:247-249.
- Nath, S., P. Coolbear, and J. G. Hampton. 1991. Hydration-dehydration treatments to protect or repair stored 'Karamu' wheat seeds. *Crop Sci.* 31:822-826.
- Oluoch, M. and G. E. Welbaum. 1994. Effects of priming on muskmelon seed storability. *Crop Sci* (submitted).
- O'Dell, G. B. and D. J. Cantliffe. 1986. Seed priming procedures and the effect of subsequent storage on germination of fresh market tomato seeds. *Proc. Fla. State Hortic. Soc.* 99:303-306.
- Owen, P. L. and W. G. Pill. 1994. Germination of osmotically primed asparagus and tomato seeds after storage for up to three months. *J. Amer. Soc. Hort. Sci.* 119:636-641.
- Perkins-Veazie, P. and D. J. Cantliffe. 1984. Need for high quality seed for effective priming to overcome thermodormancy. *J. Amer. Soc. Hort. Sci.* 109:368-372.
- Pill, W. G. 1986. Parsley emergence and seedling growth from raw, osmoconditioned and pregerminated seeds. *HortScience* 21:1134-1136.
- Pill, W. G., T. A. Evans and P. Krishan. 1994. Priming improves germination and emergence of combine-harvested *amaranthus cruentus* L. seeds. *HortScience* 29:655-658.

- Powell, A. A. and S. Matthews. 1978. The damaging effect of water on dry pea embryos during imbibition. *J. Exp. Bot.* 29:1215-1229.
- Rao, S. C., S. W. Akers and R. M. Ahring. 1987. Priming Brassica seed to improve emergence under different temperatures and soil moisture conditions. *Crop Sci.* 27:1050-1053.
- Rennick, G. A. and P. I. Tiernan. 1978. Some effects of osmopriming on germination, growth and yield of celery. *Seed Sci. Technol.* 6:695-700.
- Rivas, M., F. J. Sundstrom, and R. L. Edwards. 1984. Germination and crop development of hot pepper after seed priming. *HortScience* 19:279-281.
- Sachs, M. 1977. Priming of watermelon seeds for low-temperature germination. *J. Am. Soc. Hort. Sci.* 102:175-178.
- Schopfer, P. and C. Plachy. 1984. Control of seed germination by abscisic acid. II. Effect of embryo water uptake in *Brassica napus* L. *Plant Physiol.* 76:155-160.
- Schopfer, P. and C. Plachy. 1993. Photoinhibition of radish (*Raphanus sativus* L.) seed germination: control of growth potential by cell-wall yielding in the embryo. *Plant, Cell and Environment* 16:223-229.
- Still, D. W. and K. J. Bradford. 1994. Development of seed quality in red cabbage. *HortScience* 29:552.
- Tarkow, H., W. C. Feist, and C. F. Southerland. 1966. Interaction of wood with polymeric materials. Penetration versus molecular size. *For. Prod. J.* 16:61-65.
- Tekrony, D. and K. Egli. 1991. Review of seed vigor and crop yield. *Crop Sci.* 31:816-822.
- Thompson, R. C. 1933. A morphological study of flower and seed development in cabbage. *J. Agric. Res.* 47:215-232.

- Tokumasu, S. 1970. Effect of dry and wet storage upon seed dormancy in cruciferous vegetables. *J. Jpn. Soc. Hort. Sci.* 40:23-27.
- Tompkins, D. R. 1965. Broccoli maturity and production as influenced by seed size. *J. Amer. Soc. Hort. Sci.* 88:400-405.
- Valdes, V. M. and K. J. Bradford. 1987. Effects of seed coating and osmotic priming on the germination of lettuce seeds. *J. Amer. Soc. Hort. Sci.* 112:153-156.
- van der Toorne P. 1989. Embryo growth in mature celery seeds. *Ph.D. Dissertation*, Agricultural University, Wageningen, The Netherlands.
- Wallace, H. A. H. 1960. Factors affecting subsequent germination of cereal seeds sown in soils of subgermination moisture content. *Can. J. Bot.* 38:287-306.
- Watkins, J. R. and D. J. Cantliffe. 1983. Mechanical resistance of the seed coat and endosperm during germination of *capsicum annuum* at low temperature. *Plant Physiol.* 72:146-150.
- Weges. R. 1987. Physiological analysis of methods to relieve dormancy of lettuce seeds. *Ph.D. Dissertation*, Agricultural University, Wageningen, The Netherlands. pp. 122.
- Welbaum, G. E. and C. R. O'Dell. 1991. Effects of priming on broccoli seed germination at high temperature. *HortScience* 26:691.
- Welbaum, G. E. and K. J. Bradford. 1991. Water relations of seed development and germination of muskmelon (*Cucumis melo* L.). VI. Influence of priming on germination responses to temperature and water potential during seed development. *J. Exp. Bot.* 42:393-399.
- Weibe, H. J. and T. H. Tiessen. 1979. Effects of different seed treatments on embryo growth and emergence of carrot seeds. *Gartenbauwissenschaft* 44:280-284.
- Wolfe, D. W. and W. L. Sims. 1982. Effects of osmoconditioning and fluid drilling of tomato seeds on emergence rate and final yield. *HortScience* 17:936-937.

Wurr, D. C. E. and J. R. Fellows. 1984. The effect of grading and priming seeds of crisp lettuce cv. Saladin, on germination at high temperature, seed vigour, and crop uniformity. *Ann. Appl. Biol.* 105:345-352.

Chapter 2

Examination of Priming Treatments for Broccoli Seeds

Abstract. Priming (controlled hydration followed by redrying) improves the germination performance of broccoli (*Brassica oleracea* var. *italica* Plenck) seeds. Information on the most effective priming treatment for broccoli seeds is needed. The objective of this research was to compare liquid solutions (polyethylene glycol (PEG 8000), mannitol, and KNO_3) and solid carriers (calcium silicate and vermiculite) to osmotic- and matric-primed broccoli seeds, respectively. In addition, the most effective water potentials (Ψ s) and durations of priming were determined. Properties of the solid carriers were examined. A standard ratio of 1.0:0.8:0.8 (seed:carrier:water; by weight) was used for matric priming, and the ratio of water was increased while maintaining a fixed ratio of seeds and carrier. Respiration was measured 1 and 7 d after the seeds were placed in either calcium silicate or PEG. The most effective Ψ and priming duration were determined to be -1.2 MPa and 7 d, respectively. Polyethylene glycol was the most effective liquid osmoticum as measured by a mean time to germination (MTG) of 11.8 h. Both calcium silicate and vermiculite contain nutrients that may be taken up during the priming process. Calcium silicate was a more effective solid carrier than vermiculite. Seven days after the initiation of priming, the respiration rate of seeds primed in PEG was significantly lower than seeds primed in calcium silicate. Moreover, seeds primed in calcium silicate (1.0:0.8:1.8) for 7 d outperformed all priming treatments in the laboratory and the field as indexed by a faster rate of germination and emergence. The Ψ of seeds primed in calcium silicate was similar to the measured Ψ of seeds primed in PEG. Thus the increased performance of matric-primed seeds may be independent of Ψ alone.

Introduction

Seed priming is a controlled hydration procedure followed by redrying that permits pregerminative metabolic activities to proceed, but not radicle emergence (Heydecker and Coolbear, 1977). Primed seeds germinate faster, produce greater plant stands, and in some instances, greater yields (Khan et al., 1980). The specific priming conditions must be optimized for each species by trial and error since the invigorating effects of priming seem to be quite species specific (Bradford, 1986). Priming may improve seed vigor by one or several of the following: cellular repair and improved membrane integrity; decreased seed exudation (electrolyte leakage) and concomitant decreased growth of pathogenic organisms; enhanced mobilization of seed protein, lipid, and starch as a result of activation or synthesis of key enzymes; osmotic adjustment and increase in radical turgor; advanced embryo development; weakened restraining tissue around the embryo or radicle; and increased potential for oxidative phosphorylation and adenosine triphosphate accumulation (Pill, 1994).

Osmotic priming using liquid solutions (e.g. KNO_3 , mannitol, NaCl, and polyethylene glycol) at various water potentials (Ψ) to control seed hydration has been used successfully to prime many vegetable seeds (Heydecker et al., 1975; Bradford, 1984; Khan, 1992). However, several studies have shown phytotoxicity symptoms by using liquid solutions to control plant water relations (Jackson, 1962; Leshem, 1966; Michel, 1970). Osmotic solutions such as salt and sugars may be absorbed by plant cells resulting in nutritional, osmotic, or toxic effects (Mexal et al., 1975) Polyethylene glycol is chemically inert but may injure plants by substantially reducing oxygen availability (Mexal et al., 1975). In recent years, however, matric priming using moistened, solid carriers to

control seed hydration has often produced results superior to osmotic priming seeds (Khan, 1992).

Very little research has been conducted to devise or screen an effective priming treatment for *Brassica* spp. seeds. Akers and Holley (1984), developed a screening test for priming carrot (*Daucus carota* L.), pepper (*Capsicum annuum* L.), celery (*Apium graveolens* L.), lettuce (*Lactuca sativa* L.), tomato (*Lycopersicon esculentum* Mill.), parsley (*Petroselinum hortense* Hoffm.), and broccoli (*Brassica oleracea* var. *italica* Plenck) seeds using liquid solutions, but they did not examine matric priming.

A better understanding of which priming treatments are most effective will help determine the physiological basis of seed priming and explain why certain priming treatments are more effective than others. Since very little research is available concerning the physiology of priming, it is necessary to identify an effective priming treatment first, and then try to understand how this treatment improves germination performance. The objective of this research was to screen suitable priming agents (liquid and solid), Ψ s, and priming durations, for the purpose of devising an effective seed priming treatment for broccoli seeds.

Materials and Methods

Plant material, priming agents, and controlled hydration treatments. Broccoli seeds cvs. 'Brigadier', 'Pinnacle' (PetoSeed Co., Saticoy, CA), 'Arcadia', and 'Marathon' (Sakata Seeds America, Inc., Salinas, CA) were osmotically primed in 8.5-cm² petri dishes saturated ($\approx 7 \text{ ml} \cdot \text{g}^{-1}$ seed) with either polyethylene glycol (Carbowax, PEG 8000, Fisher Scientific Co., Fairlawn, NJ), mannitol, or potassium nitrate (KNO₃) (Fisher Scientific Co.) on two layers of filter paper (Whatman no. 1). Each dish was sealed with parafilm (American National Can, Greenwich, Conn.) to prevent evaporation. The Ψ of the PEG

solution was verified 2 h after equilibration by placing filter paper discs on the filter paper, and was ≈ 0.09 MPa lower than the initial measured value.. Seeds were matrix-primed by placing the seeds in 100 cm³ jars containing either calcium silicate (Micro-Cel E, Manville Corp., Denver, CO) or vermiculite (horticultural grade no. 2; medium grade) in varying ratios of seed:carrier:water (by weight). The appropriate amount of carrier was added to each jar, misted with distilled water, mixed using a spatula, and sealed with parafilm to prevent evaporation. After 24 h equilibration in a dark incubator at 20°C, the seeds were added to the moistened carrier and the top sealed with parafilm to prevent evaporation. Each day, the jars were rotated to mix the seeds and carrier. Moisture release curves (MRC) for hydrated calcium silicate and vermiculite were derived by drying samples in an incubator at 35°C for ≈ 15 min between Ψ readings with a thermocouple psychrometer (model no. 85, J. R. D. Merrill Inc., Logan UT). Broccoli seeds were also hydrated in water (6 h; 20°C) and redried to their initial moisture content. After priming or hydration, the Ψ of the solid carriers was determined and the water content of the seeds and carriers was determined by drying in an oven at 102°C for 17 h (ISTA, 1985).

Effective Ψ and priming duration. The time required for the cumulative germination percentage of a seed lot to plateau is the duration used for priming. The most effective Ψ for priming is the least negative Ψ that inhibits germination (Akers and Holley, 1984). Nonprimed seeds from the same lot were germinated at Ψ s ranging from 0 to -1.2 MPa in 0.2 MPa increments of PEG to determine the Ψ that just inhibited (i.e. no visible radical protrusion) germination. Three replications of 50 nonprimed seeds each (cv. 'Brigadier') were germinated at 20°C to determine the time for the seedlot to reach maximum germination. Elson et al. (1992) reported that broccoli seed germination decreased significantly at temperatures $> 30^\circ\text{C}$. Therefore, 20°C was chosen for all priming treatments.

Effective liquid and solid carrier. After suitable Ψ s were identified, germination performance of seeds osmotically primed at each Ψ was examined. For priming, PEG was prepared from -1.0 to -1.2 MPa according to Michel (1983) and verified with a vapor pressure osmometer (model 5100C, Wescor Inc., Logan, UT). For priming using mannitol, solutions were prepared from Ψ 's -1.6 to -2.4 MPa in 0.2 MPa increments and -2.5 MPa. Solutions of KNO_3 were prepared to produce Ψ s = -1.4 and -1.6 MPa, which were determined to be the least concentrated solutions that inhibited germination based on preliminary experiments. The osmotic potential of different strength molar solutions of mannitol and KNO_3 were calculated according to van't Hoff's equation and verified by psychrometry. Seeds (cv. 'Pinnacle') were primed in the most effective priming treatment for 1, 3.5, 7, and 10 days at 20°C .

Starting with a ratio of 1.0:0.8:0.8 (seed:carrier:water) by weight, the most effective matric priming treatment was developed by increasing the water content while the ratio of seed:carrier was held constant.

Respiration measurement. Seeds (cv. 'Pinnacle') were matric- and osmotic-primed as above, and respiration measured 24 h and 168 h after the treatment was begun using a Clark type O_2 electrode (model LD2, Hansatech Ltd., Norfolk, UK). A 0.01% (w/v) streptomycin sulfate solution was added to the distilled water applied to moisten the calcium silicate and formulate the PEG solution in order to reduce microbial activity. Respiration rate was measured for three replications of 100 seeds maintained at 25°C by a controlled temperature water bath (Lauda RM-6, Brinkman Instruments Inc., Westbury, NY). After measurement, the seeds were removed from the chamber, weighed, and dried at 105°C for 17 h (ISTA, 1986). Equilibrium seed moisture content (42 %) was similar for both treatments, and thus, seed respiration is expressed as $\mu\text{mol O}_2 / \text{min}/100$ seeds.

Field emergence. The most effective (as determined by germination rate) matrix and osmotic priming treatments were then screened for emergence performance in the field. Four replications of 100 seeds each were hand-sown in plots at the Virginia Tech Horticultural Research Farm in Christiansburg, VA on 5 August 1992, 15 mm deep in twin rows 15 m long and 30 cm apart with guard rows planted on either side. Seedlings were counted as emerged when the cotyledons were horizontal to the soil surface. Emergence was recorded three times per day until emergence was complete.

Statistical analysis. Mean time to germination (MTG), expressed as T_{50} , and mean time to emergence (MTE) was determined by converting cumulative germination or emergence to probits and plotting versus log time (base 10). Mean germination rate (MGR) was calculated as the inverse of the MTG. Analysis of variance was performed on the antilog values.

Results and Discussion

Characteristics of the solid carriers. Calcium silicate has a greater water holding capacity than vermiculite (Khan, 1992) (Table 2.1). This attribute, coupled with a larger particle surface area, permits the calcium silicate to attain a more uniform moisture content compared to vermiculite. The calcium silicate carrier is produced by a hydrothermal reaction of diatomaceous silica, hydrated lime, and water, resulting in a high pH (8.5). Nutrient analysis of calcium silicate performed at the Virginia Tech Soil Testing Laboratory revealed high levels of calcium (1200 ppm) and medium levels of phosphorus (15.5 ppm) (cf. Appendix Table A.1). Vermiculite contains potassium, calcium, and magnesium and has a pH = 7.0 (Nelson, 1986.).

In the range of hydration used for priming, a small decrease in the water content of both calcium silicate and vermiculite had a negligible impact on the measured Ψ (Figure 2.1 A and B). Calcium silicate, however, as reflected by a greater water holding capacity

Table 2.1 Characteristics of carriers used to prime broccoli seeds^z.

	Calcium silicate	Vermiculite no. 2
Water absorption (% by wt.)	550	410
Bulk density (kg·m ⁻³)	88	162
Surface area (m ² ·g ⁻¹)	95	11.4
pH	8.5	7.0

^z Adapted and reprinted from Khan et al., (1992).

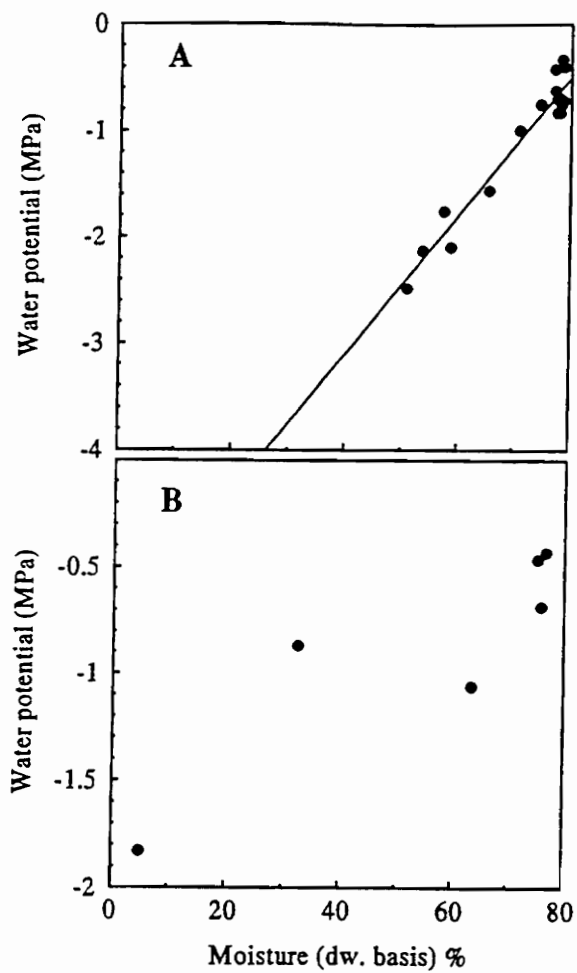

Figure 2.1. Moisture release curve for calcium silicate (Micro-Cel E) (A), and vermiculite no. 2 (B). The regression equations is: (calcium silicate), $y = -5.7 + 0.065x$ ($r^2 = 0.94$). Each point is the mean of four replications.

exhibited a relatively smaller change in Ψ with each incremental change in the water content compared with vermiculite.

Three ratios of seed:carrier:water were examined using calcium silicate as the carrier while only one ratio was examined using vermiculite. Starting with 1.0:0.8:0.8, increasing the ratio of water by two resulted in a significant amount of seeds germinating ($\geq 50\%$) in the vermiculite (data not shown). With calcium silicate, doubling the amount of water did not result in seed germination; but increasing the ratio (1.0:0.8:0.8) by 2.5 and 3.0 did. Therefore, an intermediate value (2.3x) was used as a potential treatment.

The water content of the calcium silicate at the end of priming treatment ranged from 54 to 72% (dw. basis) (Table 2.2). This corresponded with Ψ values derived from the MRC of -2.2 to -1.2 MPa for the least and most effective calcium silicate priming treatments, respectively. The vermiculite treatment had a 50% moisture content, and the Ψ from the MRC, was ≈ -0.8 MPa.

Effective Ψ for priming. An examination of the germination response of broccoli seeds to different Ψ s indicated that germination was completely suppressed at -1.2 MPa, but slight germination ($\leq 10\%$) of seeds was observed after 4 d at -1.0 MPa (Figure 2.2 B). Thus, both Ψ s were used to prime broccoli seeds. Broccoli seeds (cvs. 'Arcadia', 'Brigadier', and 'Marathon'), were primed in PEG at -1.2 MPa for 7 d and at -1.0 MPa for 3.5 d. The 'Arcadia' seedlot contained a large number of seeds with split testae and had a lower vigor compared to the other two seedlots. Nonprimed 'Arcadia' seeds exhibited a MTG of 44 h compared with ≈ 33 h for the other two cultivars. Seeds ('Arcadia' and 'Marathon') primed in PEG for 7 d at -1.2 MPa exhibited a significantly lower MTG compared with either control, nonprimed seeds or seeds primed at -1.0 for 3.5 d. Only with the 'Brigadier' seed lot, was there no significant difference between the two Ψ s. Since priming at -1.0 for longer than 3.5 d resulted in significant "overpriming" (i.e. expansive growth occurred),

Table 2.2. Percent moisture content (dw. basis) of seeds and carriers used to prime broccoli seeds.

Treatment ^z	Carrier	% moisture (carrier)	% moisture (seeds)	Ψ (carrier) (MPa)	T ₅₀ (h)	Germination (%)
1.0:0.8:0.8	calcium silicate	54	32	-2.2	24.6	97
1.0:0.8:1.6	calcium silicate	68	37	-1.3	17.8	92
1.0:0.8:1.8	calcium silicate	72	43	-1.2	6.0	90
1.0:0.8:0.8	vermiculite no.2	50	42	-0.8	14.5	94
Water-imbibed	water (0.25 h)	100	42	0.0	25.7	94
0.5 M ^y	PEG	-	39	-1.2	11.8	95
0.9 M	mannitol	-	47	-1.6	235.5	45
1.1 M	mannitol	-	46	-1.8	826.7	29
1.2 M	mannitol	-	44	-2.0	813.3	24
1.4 M	mannitol	-	45	-2.2	1921.0	18

^zAll treatments primed for 7 d at 20°C except water-imbibed seeds which were hydrated for 0.25 h at 20°C.

^yPEG was prepared as 362 g·kg⁻¹ water.

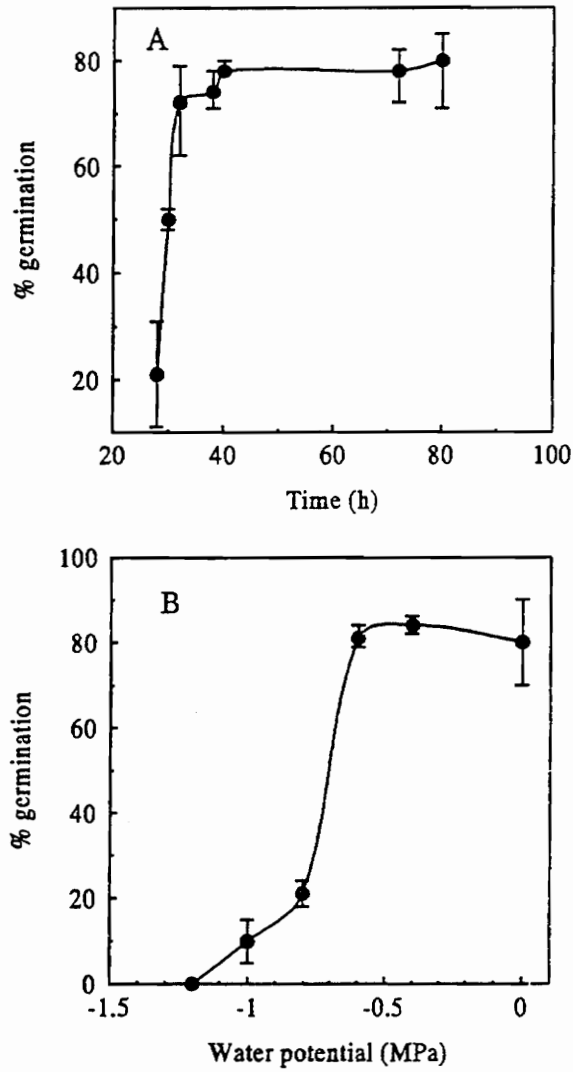

Figure 2.2. Cumulative germination of nonprimed broccoli seeds over time (**A**), and as a function of water potential (**B**).

the next lowest Ψ (-1.2 MPa) that inhibited germination was the more effective Ψ for priming broccoli seeds.

When compared with mannitol, seeds (cv. 'Brigadier') primed in PEG performed significantly better. All concentrations of mannitol had a deleterious effect on broccoli seed vigor and viability (Table 2.2) and thus should not be considered a viable liquid osmoticum for priming broccoli seeds. Mannitol, unlike PEG 8000, can penetrate the testa (Manohar, 1966). Perhaps mannitol in direct contact with the embryo was damaging and adversely affected seed vigor. Parera and Cantliffe (1992) reported that priming of leek (*Allium porum* L.) seeds in mannitol was as effective as priming in PEG. Scarascia et al. (1979), however, found that mannitol was not as effective for priming sorghum (*Sorghum bicolor* L.) seeds as PEG or NaCl.

Potassium nitrate was toxic to broccoli seeds at concentrations that inhibited germination during priming (Appendix Table A.2). Haigh and Barlow (1987) reported that priming of tomato and carrot seeds in KNO_3 had a much shorter time spread of germination than those primed in solutions without KNO_3 . It was hypothesized that the presence of nitrate during priming may provide substrate for amino acid and protein synthesis that results in enhanced germination. Since broccoli seeds are nonendospermic (i.e. the embryo is not encased by heterogenous tissue), the salt solution was perhaps more likely to have a damaging effect on the embryo, and thus the positive effects (if any) of using KNO_3 could not be realized.

Respiration rate of osmotic and matric primed seeds. Twenty-four hours after placement of seeds in calcium silicate and PEG there was no significant difference in the respiration rate (Table 2.3). However, respiration after priming for 7 d indicated that seeds primed in PEG had a relatively lower respiration rate than matric-primed seeds. This could explain the difference in germination performance between the two treatments despite maintaining

Table 2.3 Respiration rate, germination rate, and final germination percentage of matric- and osmotic-primed broccoli seeds.

Treatment	Priming duration (d)	Respiration rate ($\mu\text{mol O}_2/\text{h}/100$ seeds)	Mean germination rate (h^{-1})	Germination (%)
Matric-Primed	1	2.29	0.05	88.7
Osmotic-Primed		1.96	0.04	89.3
<i>LSD</i> _(0.05)		0.75	0.01	13.6
Matric-Primed	7	1.92	0.11	96.7
Osmotic-Primed		1.65	0.06	84.0
<i>LSD</i> _(0.05)		0.18	0.01	14.8

a similar priming duration and Ψ . At 24 h after priming, there was a slight increase in germination rate of matric-primed seeds relative to osmotic-primed seeds. At 7 d, however, the difference in germination rate between the two treatments was highly significant (Table 2.3).

The most effective matric priming treatment was determined to be calcium silicate in the ratio of 1.0:0.8:1.8. (Table 2.2). This treatment proved to be the most effective seed priming treatment for broccoli seeds, because it reduced the MTG by $\approx 50\%$ compared to the priming treatments using either PEG or vermiculite. Moreover, compared with control (nonprimed) seeds, the 1.0:0.8:1.8 treatment reduced the MTG by 83% (Table 2.2).

A short hydration in water followed by redrying of broccoli seeds was observed to result in more rapid subsequent germination (Table 2.5). Seeds primed in water germinated ≈ 10 h earlier than control, nonprimed seeds. Nath et al. (1991) reported a short (2 h) hydration of 'Karamu' wheat seeds invigorated seeds after storage. Tarquis and Bradford (1992) reported that a short hydration treatment (1 h) of lettuce seeds had little effect on germination rate but did improve root growth rate.

Duration of priming. Between 42 and 80 h after imbibition at 20°C, nonprimed broccoli seeds reached maximum germination percentage (Figure 2.2A). Therefore, durations of 24 h (1 d), 84 h (3.5 d), 168 h (7 d) and 240 h (10 d) were tested with the most effective matric and osmotic priming treatments.

Between 1 and 3.5 d, there was very little improvement in MGR of matric-primed seeds (Figure 2.3). Osmotic-primed seeds, however, exhibited a significant improvement in MGR from 1 to 3.5 d. The maximal MGR for both types of priming treatments were observed at 7 d, with the matric-primed treatment (1.0:0.8:1.8) having a much larger MGR than the osmotic-primed treatment. Priming of seeds for longer than 7 d had no

effect on seeds primed osmotically, but resulted in a significant reduction in MGR with matric-primed seeds, perhaps as a result of overpriming. Hegarty (1973) noted a significant improvement in the germination rate of onion seeds primed in -1.25 MPa PEG at 20°C as the priming duration increased to 15 d. Beyond 15 d, there was a decline in germination rate.

Field performance. In addition to being the most effective priming treatment for germination of broccoli seeds under controlled laboratory conditions, seeds primed with calcium silicate performed significantly better in the field compared with all other priming treatments and nonprimed control seeds. Matric primed seeds reduced the time to emergence by 22 h compared with nonprimed controls (Table 2.5).

In conclusion, the most effective Ψ and duration for priming broccoli seeds was determined to be -1.2 MPa and 7 d, respectively. Polyethylene glycol (PEG 8000) is more effective than KNO_3 and mannitol for priming broccoli seeds. Calcium silicate, in addition to being the most effective matric priming treatment, also performed significantly better than all priming treatments in the controlled environment of the laboratory and the often unpredictable field environment. Since the measured Ψ of the calcium silicate was equivalent to the Ψ of the most effective osmotic priming treatment (-1.2 MPa), the enhanced priming effect may be independent of Ψ alone. The reduced respiration rate of seeds primed in PEG relative to calcium silicate may indicate O_2 was limiting and account for the decreased seed vigor. Moreover, since PEG is a nonionic osmoticum, the stimulatory effect observed with matric priming may be related to nutrient uptake during the priming process. Traverse and Riekels (1973) reported that soaking of tomato seeds in 1 M MnSO_4 was sufficient to supply the Mn requirement of tomato plants grown in Mn deficient solutions. However, a substantial amount of the nutrient was located on the seed coat and was removed by washing the seeds. If nutrients are retained by seeds during

priming, it is likely that there will be substantial differences in seed structure. Tomato seeds, which are endospermic, are not likely to hold ions in proximity to the embryo. Broccoli seeds, however, are nonendospermic which may allow the ions to be more accessible to the embryo.

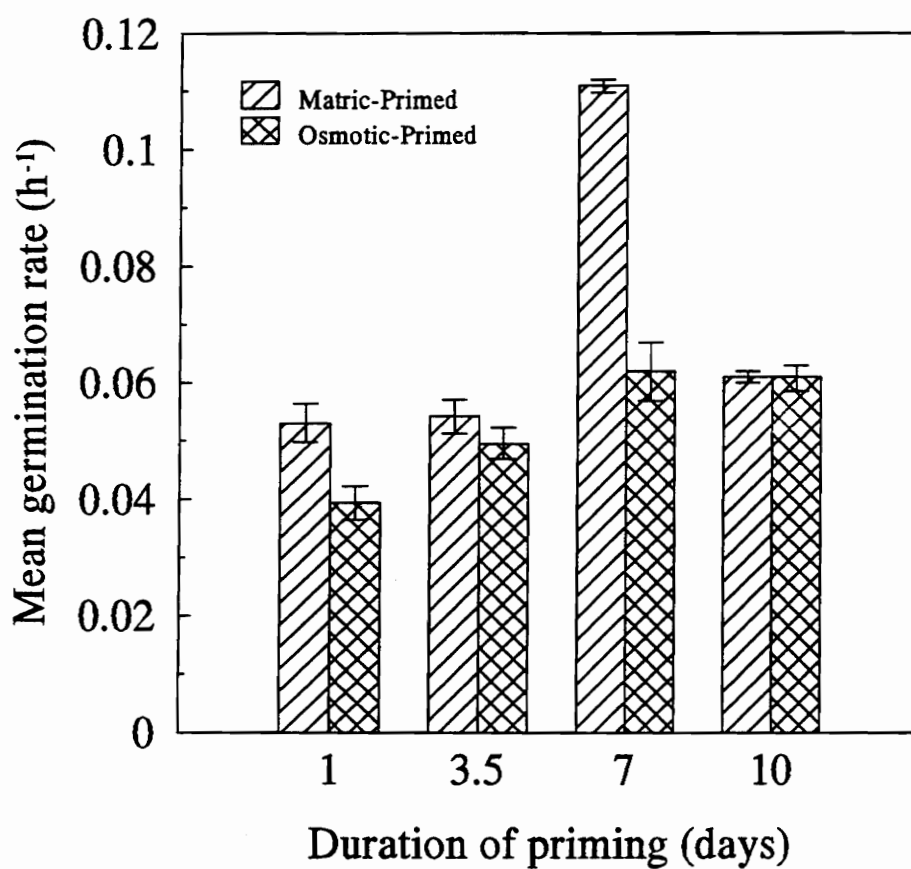

Figure 2.3. Mean germination rate of matric-primed (1.0:0.8:1.8) and osmotic-primed (PEG) broccoli seeds primed for varying durations. Vertical bars are standard errors are the means of 3 replications.

Table 2.4. Determination of an effective Ψ for PEG priming broccoli seeds.

Cultivar	Ψ^z	Duration	T₅₀	Germination
	(MPa)	(d)	(h)	(%)
<i>Arcadia</i>	-1.2	7.0	16.8	80
	-1.0	3.5	30.7	67
Nonprimed	0	0	43.7	41
	<i>LSD</i> (0.05)		13.4	16
<i>Brigadier</i>	-1.2	7.0	13.4	95
	-1.0	3.5	8.4	99
Nonprimed	0	0	31.3	99
	<i>LSD</i> (0.05)		7.5	8
<i>Marathon</i>	-1.2	7.0	12.3	94
	-1.0	3.5	14.8	90
Nonprimed	0	0	32.3	84
	<i>LSD</i> (0.05)		2.1	8

^z Ψ of polyethylene glycol (PEG 8000)

Literature Cited

- Akers, S. W. and K. E. Holley. 1984. A screening process to establish effective priming treatments for vegetable seed. *HortScience* 19:211.
- Bradford, K. J. 1986. Manipulation of seed water relations via osmotic priming to improve germination under stress conditions. *HortScience* 21:1105-1102.
- Elson, M. K., R. D. Morse, D.D. Wolf, and D. H. Vaughn. 1992. High temperature inhibition of seed germination and seedling emergence of broccoli. *HortTechnol.* 2:417-419
- Haigh, A. M. and E. W. R. Barlow. 1987. Germination and priming of tomato, carrot, onion, and sorghum seeds in a range of osmotica. *J. Amer. Soc. Hort. Sci.* 112:202-208.
- Hegarty, T. 1973. A new idea for improving seed germination. *Nature* 246:42-44.
- Heydecker, W., J. Higgins, and Y. J. Turner. 1975. Invigoration of seeds? *Seed Sci. Technol.* 3:881-888.
- Heydecker, W. and P. Coolbear. 1977. Seed treatments for improved performance. Survey and attempted prognosis. *Seed Sci. Technol.* 5:353-425.
- International Seed Testing Association. 1985. International rules for seed testing. *Seed Sci. Technol.* 13:299-520.
- Jackson, W. T. 1962. Use of carbowaxes (polyethylene glycols) as osmotic agents. *Plant Physiol.* 37:513-519.
- Khan, A. A., N. H. Peck, and C. Samimy. 1980. Seed osmoconditioning: physiological and biochemical changes. *Israel J. Bot.* 29:133-144.
- Khan, A. A. 1992. Preplant physiological seed conditioning. *Hortic. Rev.* 51:53-76.
- Leshem, B. 1966. Toxic effects of carbowaxes (polyethylene glycols) on *Pinus halepensis* Mill. seedlings. *Plant Soil* 24:322-324.

- Manohar, M. S. 1966. Effects of "osmotic" systems on germination of peas (*Pisum sativum* L.). *Planta* (Berlin) 71:81-86.
- Michel, B. E. 1983. Evaluation of the water potentials of solutions of polyethylene glycol 8000 both in the absence and presence of other solutes. *Plant Physiol.* 72:66-70.
- Nath, S., P. Coolbear, and J. G. Hampton. 1991. Hydration-dehydration treatments to protect or repair stored 'karamu' wheat seeds. *Crop Sci.* 31:822-826.
- Nelson P. V. 1986. Root media. In: *Greenhouse Operation and Management.* p 185-187. Reston Publishing Co. Inc., Reston, VA
- Parera, C. A. and D. J. Cantliffe. 1992. Priming of leek seed for improved germination and emergence at high temperature. *HortScience* 27:1077-1079.
- Scarascia, M. E. V. M. de Lucia, and M. Mastorilli. 1979. Germinazione di semi di sorgo in condizioni di stress idrico simulato. *Ann. Inst. Sper. Agron.* 10:119-133.
- Tarquis, A. A. and K. J. Bradford. 1992. Prehydration and priming treatments that advance germination also increase the rate of deterioration of lettuce seeds. *J. Exp. Bot.* 43:307-317.
- Traverse, R. J. and J. W. Riekels. 1973. Manganese enrichment of tomato and onion seed. *J. Amer. Soc. Hort. Sci.* 98:120-123.

Chapter 3

Laboratory and Field Performance of Primed and Nonprimed Broccoli Seeds

Abstract. Priming (controlled imbibition of seeds followed by redrying) improves germination and emergence of several species of vegetable seeds. More information is needed concerning the effects of priming on seeds of *Brassica* spp. Laboratory and field performance of broccoli (*Brassica oleracea* var. *italica* Plenck) seeds were compared after osmotic priming in polyethylene glycol (PEG) at -1.2 MPa or matric priming in moistened, calcium silicate (Micro-Cel E) or vermiculite no. 2. Germination rate and root length were recorded from 10 to 40°C and 10 to 35°C, respectively. Electrolyte leakage was measured at 35 and 38°C. Emergence and seedling growth were evaluated in a greenhouse and the field. Matric priming using calcium silicate (1.0 g seed:0.8 g carrier:1.8 ml water) improved germination and root growth of broccoli seeds at stressful temperatures more than the other treatments. Root length was significantly reduced at $> 30^{\circ}\text{C}$ and was more sensitive to high temperature than germination. Primed seeds leaked less electrolytes at both 35 and 38°C compared to nonprimed seeds. Matric-primed seeds consistently emerged earlier in the greenhouse and field through crusted and noncrusted soils, although there were no significant differences in shoot or root relative growth rates. The advantages of earlier emergence (36 h) of matric-primed seeds did not result in an earlier harvest. In the Southeast, where temperature extremes and soil crusting are problems in stand establishment, matric priming of broccoli seeds using calcium silicate is an effective seed treatment for improving plant stands of direct-seeded broccoli.

Introduction

Bunching broccoli (*Brassica oleracea* var. *italica* Plenck) is often direct-seeded at double the final spacing and then thinned to 10.8 plants/m² (O'Dell, 1990). When seedling stands are optimized, a greater concentration of harvest may be achieved, which in turn, results in increased harvest efficiency and decreased harvesting costs (Heather and Sieczka, 1991). Successful stand establishment of direct-seeded, fall broccoli in the southeastern United States is complicated by supraoptimal soil temperature and soil crusting which cause erratic germination and emergence and reduced yields (Sterrett et al., 1990; Elson et al., 1992; Jett et al., 1995;). Improving germination performance at high temperatures and in crusted soils could improve broccoli stands, reduce the need for thinning, and increase yields.

One technique for improving broccoli seed germination is priming or conditioning. Priming is a controlled hydration process followed by dehydration that presumably allows pregermination metabolic activities to proceed, but not radical emergence (Heydecker and Coolbear, 1977). For osmotic priming, seeds are incubated in solutions of salt (e.g. KNO₃, NaCl, and K₃PO₄) or high molecular weight non-penetrating organic solutes (e.g. polyethylene glycol) at a water potential (Ψ) low enough to inhibit germination (Khan, 1990). Osmotic priming improves seed vigor in a wide range of vegetable species including many *Brassica* spp. such as Brussels sprouts (*Brassica oleracea* var. *gemmifera*), cabbage (*Brassica oleracea* var. *capitata*) (Khan et al., 1981; Bradford, 1986), and kale (*Brassica napa* L.) (Rao et al., 1987). Moreover, osmotic priming of *Brassica* spp. seeds increases seed vigor in cold, moist soils (Rao et al., 1987).

Broccoli seeds do not possess endosperm tissue surrounding the embryo (nonendospermic). Salt solutions can damage embryo tissue and are generally not used for priming nonendospermic seeds (Bradford, 1986). Polyethylene glycol is an effective

osmoticum for priming *Brassica* spp. seeds; however, the high cost of PEG, its high viscosity, the difficulties associated with handling large volumes of liquid, and the fact that PEG can be damaging to certain seeds (Mexal et al., 1975; Mobayen and Milthorpe, 1978) have led to the development of alternative methods of priming (Khan, 1992).

Matric priming uses moistened, solid carriers instead of liquid osmotica to prime seeds. Matric priming is superior to osmotic priming in several species of vegetable seeds and is being more widely used commercially (Khan, 1992). No research examining matric priming as a method to enhance vigor of *Brassica* spp. seeds has been conducted.

The effects of priming on germination at sub and supraoptimal temperatures has not been investigated. Røeggen (1986) reported that the minimum temperature allowing germination of *B. oleracea* was 0.1 to 2.9°C. Elson et al. (1992) observed that final germination percent of broccoli seeds decreased linearly above 30°C. Priming may reduce the minimum and increase the maximum temperatures for broccoli seed germination. Intrinsic characteristics govern the way seeds germinate under various conditions of temperature and Ψ . The thermal time model proposed by Garcia-Huidobro et al. (1982) can be used to explain how priming affects the germination of broccoli seeds at different constant temperatures. According to this theory, germination rate is a function of the product of the difference between the imbibition temperature and the base temperature (minimum temperature for germination) and the mean time to germination (MTG). The objectives of this research were to determine the optimum priming treatment for broccoli seeds and to determine how priming affects germination performance at high and low temperatures in the laboratory and the field.

Materials and Methods

Plant material and priming treatments. Broccoli seeds cvs. 'Brigadier' and 'Earlidawn' (Petoseed Co., Saticoy, CA) were osmotically primed in polyethylene glycol (Carbowax, PEG 8000, Fisher Scientific Co., Fairlawn, NJ) solutions of -1.1 MPa ($30.6 \text{ g}\cdot\text{kg}^{-1}$), prepared according to Michel (1983) and verified by osmometry (model 5100C, Wescor Inc., Logan, UT). Seeds were incubated in the dark on two thicknesses of germination blotter paper (Anchor Paper Co., St. Paul, Minn.) saturated with PEG ($\approx 7 \text{ ml}\cdot\text{g}^{-1}\text{seed}$) in 8.5 cm^2 petri dishes sealed with parafilm (American National Can, Greenwich, Conn.) to prevent evaporation. For matric priming, broccoli seeds were placed in 100 cm^3 jars containing either vermiculite (medium grade no. 2) or moistened Micro-Cel E (Manville Corp., Denver, CO). Micro-Cel E is a synthetic calcium silicate, produced by a hydrothermal reaction of diatomaceous silica, hydrated lime and water. vermiculite (medium grade; no. 2). 'Earlidawn' seeds were matric primed for field experiments in 1990 to 1993 with vermiculite (1.0 g seed:0.8 g carrier:0.8 ml water). 'Brigadier' seeds were primed with both calcium silicate (1.0:0.8:1.8) and vermiculite (1.0:0.8:0.8) after screening of varying ratios of seed:carrier:water (cf. chapter 2). The precise amount of water and carrier were mixed thoroughly. Twenty-four hours later, the seeds were mixed to give a uniform mixture of seeds, carrier, and water. The jars were sealed with parafilm and incubated in darkness. Each day the jars were rotated one complete turn to ensure mixing of seeds, solid carrier, and water. Since broccoli seeds may exhibit thermoinhibition at temperatures $> 30^\circ\text{C}$ (Elson et al., 1992), all priming was performed at 20°C for 7 d. The equilibrium Ψ of the seeds primed in calcium silicate was measured using a thermocouple psychrometer (model 85, J. R. D. Merrill, Logan, UT) calibrated using NaCl solutions of known Ψ verified by osmometry.

After priming, seeds were removed either from solid or liquid carriers, vigorously rinsed in tap water for 2 min and briefly rinsed in 200 ml of distilled water. The seeds were blotted dry and forced-air dried (37°C) for 20 min. Seeds were then dehydrated in a silica gel desiccator (45% RH) to a final moisture content of 5 to 6% (dw. basis) determined by oven drying at 102°C for 17 h (ISTA, 1985). The seeds were recoated with thiram (tetramethylthiuram disulfide), sealed in plastic bottles, and stored at 4°C. The moisture content of the solid carriers was determined after the seeds were removed by drying at 102°C for 17 h.

Laboratory germination and root growth evaluation. To analyze germination performance across a range of temperatures, a 110x136 cm one-dimensional thermogradient table was used to test germination at 5, 10, 15, 20, 25, 30, 35, 36, 38, and 40°C. Temperatures on the table were logged hourly using a digital data recorder (Omnidata Intl. Inc., Logan, UT), and the maximum temperature fluctuation during the course of the germination experiments was less than 1°C. Twenty seeds (primed and nonprimed) were placed on two thicknesses of germination blotter paper in 4.5-cm-diameter petri dishes and wetted with 4 ml of distilled water. The dishes were randomized within each temperature (block) on the table in a randomized complete block design with three replications. Germination (visible radical protrusion) was scored at 2-h intervals for the first 3 d after imbibition and 6 h thereafter. Mean time to germination (denoted either as t_{50} or MTG), mean time to emergence (MTE), and mean time to harvest (MTH), were calculated by plotting cumulative germination, emergence, or heads harvested on a probit scale versus log (base 10) time. Mean thermal time to germination (θ_T ; °h) was calculated by the equation

$$\theta_T = (T - T_b)t \quad (1)$$

where T is the germination temperature, T_b is the minimum or base temperature for germination, and t is the mean time to germination. Rearranging in terms of mean germination rate (MGR) gives

$$MGR = (T - T_b)t/\theta_T \quad (2)$$

The mean germination rate (MGR) was calculated as the inverse of the MTG. MGR was plotted as a function of temperature, and linear regression was used to calculate the base temperature (T_b) for germination and root growth and the maximal temperature for root growth (T_{max}) where $MTG^{-1} = 0$ on the abscissa. The thermal time constant (θ_T) was calculated as the inverse slope of the regression of germination rate versus log (base 10) time from 10 to 25°C (Gummerson, 1986; Argerich and Bradford, 1989).

Root growth was evaluated at 10, 15, 20, 25, 30, and 35°C. Three replications containing 50 seeds were incubated on moist blotters wetted with 15 ml of distilled water. When radical protrusion was observed to ≈ 1 mm, 10 germinated seeds were transferred to rows 4 cm from the top of 12x15 cm germination blotters (Anchor Paper Co.). The blotter and seedlings were covered with another water-saturated blotter, placed on plexiglass slant boards (45° angle) in a dark incubator and covered with plastic bags to prevent evaporation (McCormack and Keefe, 1990). At 48 h after transfer, root lengths were measured using calipers (digimatic; Mitutoyo Corp., Tokyo, Japan).

Leachate conductivity. Five replications of 10 seeds each of primed (osmotic) and nonprimed seeds were examined with a dissecting microscope, and seeds with split seed coats were removed, leaving only visibly intact seeds for analysis. The nonprimed seeds were washed in tap water duplicating the treatment used to remove PEG from seeds after priming. Five batches (primed and nonprimed) of 10 seeds each were soaked in 2 ml of double distilled water at 35 and 38°C. Leachate conductivity was measured every 30 min

up to 120 min by a conductivity meter (CDM 83, Radiometer, Copenhagen, Denmark) and expressed as $\mu\text{S}\cdot\text{seed}^{-1}$.

Emergence experiments. To evaluate emergence under controlled conditions, seeds were sown 15 mm deep in 11-cm-diameter pots filled with Pro-mix BX media (Fisons Horticultural Inc., Ontario, Can.) in a greenhouse in which the average day/night temperatures were 25/20C. Supplemental lighting (1000 watt, 60HZ, Sylvania Corp.) was used to deliver a 14-h photoperiod. Seedlings were hand-watered daily until harvest. Three replications of 10 seeds each were arranged in a randomized complete block design on a greenhouse bench. Emergence was considered complete when the cotyledons were horizontally oriented. The seedlings were cut at the soil line 16, 30, and 44 days after sowing (DAS). The roots were isolated by washing away the media with tap water. Roots and shoots were weighed fresh and dried at 70°C. Relative growth rates were calculated for shoots and roots according to Radford (1967).

Priming of broccoli seeds increases seed volume (unpublished results). To test if this increase in volume affected the ability to mechanically sow primed seeds, four replications of primed and nonprimed seeds were metered through a Stanhay S-870 Precision-Seeder (Stanhay Corp., Dixon, CA). Seeds were collected after movement through the seeder and examined for mechanical damage.

Field emergence of primed and nonprimed 'Brigadier' seeds was evaluated at the Virginia Tech Horticultural Research Farms in Christiansburg and Blacksburg, VA. Matric (using vermiculite and calcium silicate)-primed seeds were evaluated for emergence in the field in 1992. Four replications of 100 seeds each were hand-sown on 5 August 15 mm deep in twin rows 15 m long and 30 cm apart with guard rows planted on either side. The same year, the matric primed seed treatment that performed significantly better in the previous experiment was evaluated for emergence under crusted soil conditions by

applying ≈ 1.7 cm of sprinkler irrigation water after seeding. Emergence was recorded three times per day until no further emergence was observed. In 1993, emergence was again evaluated in crusted soils using four replications of 40 seeds each of 'Brigadier'. Soil temperatures were recorded during the emergence period by placing thermocouples at seeding depth.

Matric-primed, osmotic-primed, and nonprimed 'Earlidawn' seed emergence was also examined in the field over a three year period. In 1990, only osmotic-primed and nonprimed seeds were evaluated on a commercial broccoli farm in southern Virginia. Four replications of one hundred seeds each were seeded as above. In 1991 and 1992, emergence of both matric and osmotic primed seeds was evaluated at the Virginia Tech Horticultural Research Farm in Christiansburg, VA. The soil was a Groseclose silt loam with a pH of 6.2. In 1991 and 1992, head yields were determined. In 1991, an early freeze prevented collection of harvest data for the entire season. Heads were harvested daily when a minimum head diameter of 14 cm was attained. The entire plant was cut at the soil line and weighed followed by removing the peripheral leaves of the stalk and weighing each head cut to a length of 19 cm (USDA, 1943).

Results and Discussion

Seed moisture content. The equilibrium seed moisture content (dw. basis) of seeds primed in PEG, calcium silicate, or vermiculite ranged from 39% to 43% (dw. basis) (Table 3.1). The equilibrium seed Ψ was similar for seeds primed in calcium silicate and PEG. The vermiculite seemed to have moist and dry areas despite daily rotation of the mixture. The Ψ of the seeds primed in vermiculite was higher, which resulted in premature germination of 1 to 5% of the seeds. No premature germination was observed in the calcium silicate

Table 3.1. Liquid and solid carriers used, ratios of seed:carrier:water (by weight), moisture content of seeds and carriers, and the measured water potential (Ψ) of the seeds.

Treatment ^z	Carrier/Osmoticum	Water content (%)		Ψ (MPa)
		Seed ^y	Carrier ^x	
1.0:0.8:1.8	Calcium silicate	43	62	-1.2
1.0:0.8:0.8	Vermiculite	42	50	-1.0
(0.5 M)	PEG	39	64	-1.2
<i>Significance</i> ^w		<i>NS</i>	**	<i>NS</i>

^zRatio of seed:carrier:water ratio (by weight). Osmotic-primed treatment expressed as w/w basis of PEG (362 g·kg⁻¹ water).

^yInitial moisture content of seeds, 6%.

^xInitial moisture content of carriers, 6 to 10%.

^{w**} Significant at P = 0.05.

treatment. The higher surface area of calcium silicate ($95 \text{ m}^2 \text{ g}^{-1}$) versus vermiculite no. 2 ($11.4 \text{ m}^2 \cdot \text{g}^{-1}$) seems to provide better carrier:water equilibrium (Khan et al., 1992).

Comparison of carriers. In a standard laboratory germination test, seeds primed in calcium silicate (1.0:0.8:1.8) had a significantly lower MTG than nonprimed or seeds primed in vermiculite or PEG (Table 3.2). This performance was also observed in the field, where seeds primed in calcium silicate had a significantly lower MTE. Therefore, given the problems associated with moisture equilibration of vermiculite-primed seeds, only seeds primed in calcium silicate were evaluated further.

Laboratory performance. The optimal range of temperatures for maximum final germination of primed and nonprimed seeds was 20 to 35°C (Figure 3.1 A). Wilson et al. (1992) reported that the optimal germination temperature for several forage species of *Brassica* occurred between 10 and 35°C. In our study, at temperatures greater than 35°C, both primed and nonprimed seeds exhibited a decline in germination percentage. The maximum germination temperature for nonprimed seeds was 36°C. However, both matrix and osmotic-primed seeds germinated at 38°C and ($\leq 10\%$) at 40°C. Thus, priming did not increase seed viability over the temperature range of 5 to 35°C, but at high ($\geq 36^\circ\text{C}$) temperatures, priming significantly increased the final germination percent compared to nonprimed seeds.

Contrary to what was reported by Elson et al. (1992), there was no reduction in final percentage germination beyond 30°C observed with either primed or nonprimed broccoli seeds. Gray (1978) identified the stages of germination when lettuce (*Lactuca sativa* L.) seeds were most sensitive to high temperature and discovered that priming alleviated thermoinhibition by allowing sensitive stages to be completed under more optimal temperature conditions. The higher germination percent of primed broccoli seeds at temperatures $> 35^\circ\text{C}$ supports the hypothesis that certain rate-limiting steps may be

Table 3.2. Summary of field and lab performance of matrix- and osmotic-primed broccoli seeds.

Treatment ^z	Carrier/osmoticum ^y	Laboratory performance ^x		Field performance	
		T ₅₀ (h)	Germination (%)	T ₅₀ (d)	Emergence (%)
1.0:0.8:1.8	Calcium silicate	5.4	72.8	6.2	73.8
1.0:0.8:0.8	Vermiculite	12.4	80.8	7.1	63.5
362 g kg ⁻¹	PEG	12.0	77.1	6.8	64.5
Nonprimed		22.4	78.5	7.1	53.0
<i>LSD</i> (0.05)		6.6	24.9	0.5	12.5

^zMatrix primed seed treatments expressed as seed:carrier:water.

^yOsmotic primed treatment expressed as w/w basis of PEG and water.

^xGermination performed at 25°C. T₅₀ is the time to 50% germination or emergence.

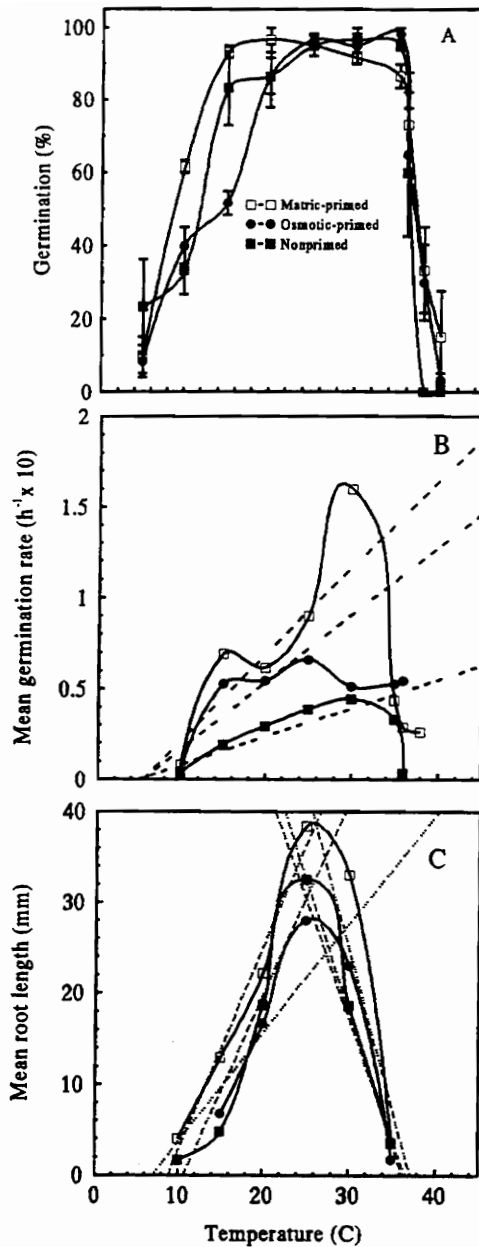

Figure 3.1. Germination percent (A), germination rate (B), and root length (C), of matric-primed, osmotic-primed, and nonprimed broccoli seeds as a function of temperature. The vertical bars in panel A represent the standard error of the mean of three replications. In panel B, the dashed lines are the least squares regression lines, and the regression equations (10 to 25 °C) are: (matric-primed), $y = -0.300 + 0.049x$ ($r^2 = 0.77$); (osmotic-primed), $y = -0.204 + 0.037x$ ($r^2 = 0.78$); (nonprimed), $y = -0.181 + 0.024x$ ($r^2 = 0.94$). For panel C, the dashed lines are the least squares regression lines, and the regression equations (10 to 25 °C) are: (matric-primed), $y = -8.394 + 1.20x$ ($r^2 = 0.72$); (osmotic-primed), $y = -22.8 + 2.1x$ ($r^2 = 0.94$); (nonprimed), $y = -19.9 + 2.3x$ ($r^2 = 0.98$); 25 to 35 °C; (matric-primed) $y = 96.3 - 2.625x$ ($r^2 = 0.89$); (osmotic-primed), $y = 105.2 - 2.9x$ ($r^2 = 0.99$); (nonprimed), $y = 129.4 - 3.5x$ ($r^2 = 0.86$).

completed during the priming process, thus allowing germination at higher temperatures than nonprimed seeds.

The MGR of nonprimed seeds peaked at 30°C and declined sharply with higher temperatures (Figure 3.1 B). Priming significantly increased the germination rate at most temperatures, but the increase was greater at higher temperatures. The highest MGR of osmotic primed seeds was observed at 25°C, while seeds primed in calcium silicate had the highest MGR at 30°C. The maximum MGR of matric primed seeds was observed between 25 and 30°C.

Calculation of the maximal temperature for germination was hampered by non-linear responses of primed and nonprimed seeds at high (> 30°C) temperatures (Figure 3.1 B). Priming (both matric and osmotic) had no significant effect on the base temperature (T_b) for germination, but allowed seeds to germinate at higher temperatures than nonprimed seeds, thus increasing the maximal germination temperature (T_{max}) as determined by final percent germination (Figure 3.1). Welbaum and Bradford (1991) reported that priming lowered T_b as a result of physiological maturation that occurred during priming. In contrast, researchers working with tomato seeds (Argerich and Bradford, 1989; Dahal, 1990) and onion (Ellis and Butcher, 1988) reported that priming did not lower T_b but decreased the thermal time required for germination. In the absence of dormancy T_b is genotypically controlled (Ellis et al., 1987). Priming, unless it removes dormancy, is not likely to affect T_b . Matric priming of broccoli seeds lowered the thermal time constant (θ_T) required for germination by 50 and 21% compared to nonprimed and osmotic-primed seeds, respectively (Figure 3.1). Thus, according to the thermal time model, priming allowed seeds to make a greater progression towards germination per unit temperature while maintaining a constant T_b .

Table 3.3. Seed germination and root growth characteristics of broccoli in response to priming.

Treatment	T_b (°C)	T_{max} (°C)	θ_T (° h)
<u>Germination</u>			
Matric primed	4.9	39.9	210
Osmotic primed	5.2	N/A	267
Nonprimed	7.3	38.4	423
<i>Significance^z</i>	<i>NS</i>	<i>NS</i>	*
<u>Root Growth</u>			
Matric primed	8.4	37.3	N/A
Osmotic primed	11.9	36.9	N/A
Nonprimed	11.3	37.3	N/A
<i>Significance</i>	*	<i>NS</i>	

* NS Significant or nonsignificant at P = 0.05 respectively. N/A indicates not applicable.

Leachate conductivity. Solute leakage is used as a vigor test with several seed species (AOSA, 1983). Primed seeds leaked less electrolytes at 35 and 38°C compared to nonprimed seeds (Figure 3.2). Increasing the temperature from 35 to 38°C did not significantly affect the amount of electrolytes lost from primed seeds but did increase the amount lost from nonprimed seeds. Substances leaking into the soil from seeds can stimulate the growth of fungal pathogens (Schoth and Cook, 1964). The majority of nonprimed seeds imbibed at temperatures >36°C were eventually colonized by pathogenic organisms. Parera and Cantliffe (1992) reported that leakage of electrolytes from *sh-2* sweet corn (*Zea mays* L.) was significantly reduced after priming and resulted in a greater plant stand than nonprimed seeds. The reduced leakage of electrolytes from primed broccoli seeds at supraoptimal temperatures may be the result of electrolyte leakage during priming so that, upon reimbibition, less were leaked. However, nonprimed seeds were also washed, which might at least partially remove electrolytes from the apoplast prior to measurement. In addition, when the imbibition temperature was increased from 35 to 38°C, electrolyte leakage increased significantly in nonprimed seeds but primed seeds exhibited little change. Cell membranes play a key role in modulating the effect of high temperature on plant growth (Raison, 1984). Priming perhaps confers some degree of membrane stability to germinating broccoli seeds at supraoptimal temperatures, thus expanding the temperature range of germination.

Root growth. Root length increased over the temperature range 10 to 25°C for both primed and nonprimed seeds (Figure 3.1 C). At temperatures exceeding 25°C, there was a significant decline in mean root length of osmotic-primed and nonprimed seeds. The root lengths of matric-primed seeds did not differ at 25 and 30°C, reflecting the temperature range at which maximal vigor was observed. At low (15°C) and high (30°C) temperatures, osmotic primed seedlings had a significantly greater root length than

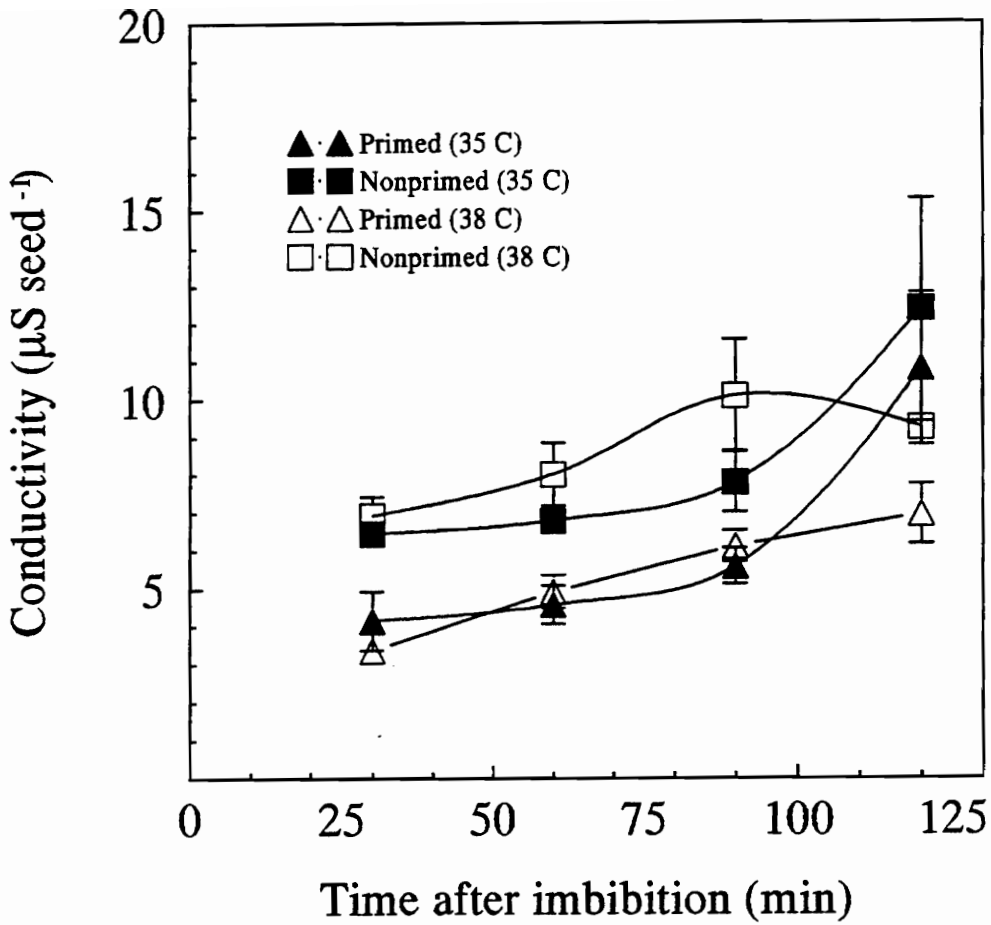

Figure 3.2. Electrolyte leakage of primed and nonprimed broccoli seeds at 35 and 38°C. Vertical bars represent standard errors of the means of five replications.

nonprimed seedlings. At supraoptimal temperatures ($\geq 30^{\circ}\text{C}$), root growth of all treatments decreased dramatically, culminating at 35°C with no significant difference among treatments. Thus, priming of broccoli seeds increased the germination rate from sub to supraoptimal temperatures, but root growth or the events associated with emergence were more sensitive to temperature than germination. Priming improved seed germinability above 35°C , however, root growth was so markedly inhibited that the seedling was not likely to emerge.

Argerich and Bradford (1989) found no significant difference in mean root length of osmotic-primed and nonprimed tomato (*Lycopersicon esculentum* Mill.) seedlings after 48 h at 25°C . In my study, matric-primed seeds demonstrated significantly greater root growth at all temperatures, which agrees with data on germination rate and subsequent seedling performance (Finch-Savage, 1986).

Matric-primed seeds had a lower T_b for root growth than either osmotic-primed or nonprimed seeds (Table 3.3). The T_b for germination was significantly lower than the T_b for root growth for osmotic-primed and nonprimed seeds, but not for matric-primed seeds. There was no significant difference in T_{max} for root growth for either the matric-primed or nonprimed seeds.

Emergence. Priming significantly reduced the mean time to emergence (MTE) compared with control, nonprimed seeds in the greenhouse. Matric-primed seeds emerged 36 h earlier than nonprimed seeds and 13.7 h earlier than osmotic-primed seeds (cf. Appendix, Table A.3). Moreover, matric-primed seeds had a significantly greater final emergence compared with osmotic-primed and nonprimed seeds. Sixteen days after seeding (DAS), matric-primed seedlings had significantly greater shoot weight (both fresh and dry) than either osmotic-primed or nonprimed seeds (Table 3.4). This significant increase (as a result of earlier emergence), was not retained by 30 and 40 DAS, however, as observed by

Table 3.4. Sequential harvest of primed and nonprimed broccoli seedlings in a greenhouse.

Treatment	Fresh wt. (g/plant)						Dry wt. (g/plant)												
	16			30			44 ^a			16			30			44			
	Shoot	Root	Shoot	Root	Shoot	Root	Shoot	Root	Shoot	Root	Shoot	Root	Shoot	Root	Shoot	Root	Shoot	Root	
Matric-Primed	3.52	0.73	43.6	81.3	90.4	0.34	0.05	6.7	5.6	16.6									
Osmotic-Primed	2.95	0.57	38.0	75.5	90.1	0.29	0.04	6.0	5.4	16.2									
Nonprimed	2.50	0.46	36.0	60.9	89.5	0.15	0.13	5.5	4.3	15.9									
LSD (0.05)	0.86	0.16	12.4	55.5	10.3	0.16	0.22	1.6	3.4	3.3									

^aAt 44 DAS, it was not possible to accurately separate roots from media,

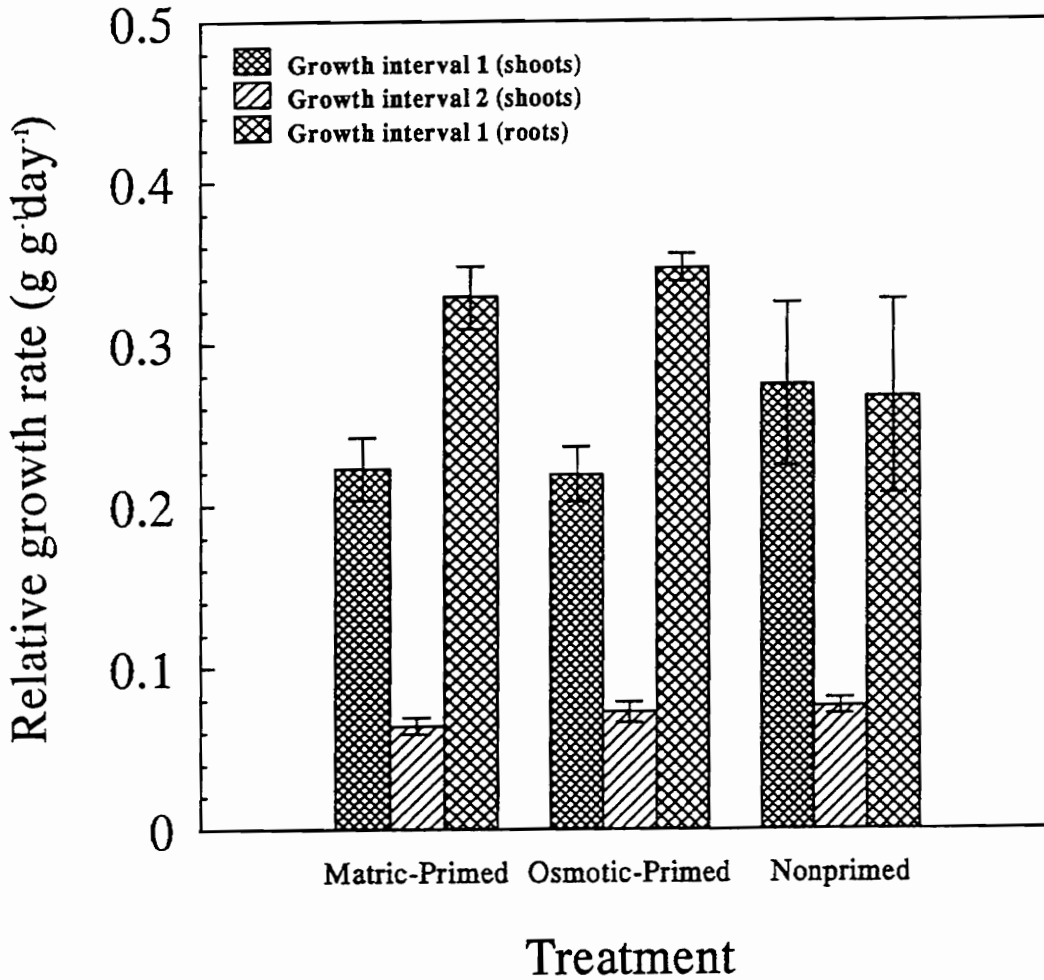

Figure 3.3. Relative growth rate of shoots and roots of matric-primed, osmotic-primed, and nonprimed seedlings in the greenhouse. Growth interval 1: day 16 to day 30; Growth interval 2: day 30 to day 44. Vertical bars represent the standard error of the mean of four replications.

the lack of significant difference in shoot and root relative growth rate (Figure 3.3). Between 16 and 30 DAS, the relative growth rate of the roots was significantly greater than for the shoots, which declined for all treatments with time. Root length is not a sensitive indicator of growth or field performance and can underestimate seedling performance (Argerich and Bradford, 1989). The metabolic events that control seedling growth are quite different from the events that control germination rate (Scott and Jones, 1985a). Thus, matric priming's advantage of earlier germination and emergence coupled with attributes associated with the solid carrier itself, does not impart a long-lasting advantage on seedling growth (cf. chapter 2). Khan (1980) discovered that osmotic priming of cabbage and Brussels sprouts seeds reduced the MTE by 2 to 4 d, and that translated into a significant increase in fresh weight of the plants at harvest. Alvarado et al. (1987) determined that the advantage in earlier emergence (4 d) of tomato was maintained through early leaf development (26 days after planting) but was eventually lost later in the growth cycle. In this study, the difference in MTE was observed to be less than 2 d. Thus, the benefits of early emergence would not be long-lived throughout the growth of the seedling.

Increasing the rate of emergence through priming may also allow seedlings to escape adverse environmental conditions, (Gray, 1976; Salter et al., 1981; Wurr and Fellows, 1983; TeKrony and Egli, 1992;). Soil crusting could result in late-emerging seedlings that could be at a competitive disadvantage that could also affect yield (TeKrony and Egli, 1992).

Precision seeding of broccoli seeds resulted in no visible mechanical damage to primed seeds. In the field, matric-primed seeds consistently had a lower MTE in crusted soils both years of the study (Table 3.5). Also, in 1993, final stand percentages were higher with matric primed seeds compared to both nonprimed and osmotic-primed seeds because the

Table 3.5. Emergence of primed and nonprimed broccoli seeds in crusted soils.

Year	Treatment	T ₅₀ (emergence)	Emergence
		(h)	%
1992	Matric-primed	95.0	74.3
	Osmotic-primed	117.8	66.3
	Nonprimed	136.0	64.3
	<i>LSD</i> _(0.05)	10.7	16.1
1993	Matric-primed	85.3	75.6
	Osmotic-primed	126.0	61.3
	Nonprimed	159.7	54.4
	<i>LSD</i> _(0.05)	30.5	11.6

increased the germination rate allowed seedlings to escape the stress of soil crusting. In 1990, under severe crusted soil conditions, priming (osmotic) did not reduce the MTE or increase final stand percentage. Yet, primed seeds produced a more uniform stand, which resulted in a greater percentage of plants being harvested and yield (cf. Appendix, Table A.4), and a significantly reduced mean time to harvest (MTH) (Table 3.6). In 1992 and 1993, matric primed seeds exhibited greater vigor than either osmotic-primed or nonprimed seeds. In 1992, matric-primed 'Earlidawn' seeds emerged \approx 14 h earlier than nonprimed seeds and produced a 10% increase in plant stand, but this advancement in emergence did not translate into a significantly reduced MTH compared to nonprimed seeds.

Nonprimed seeds produced fewer plants per unit area than primed seeds (Table 3.5). This decrease in plant density resulted in a significantly larger plant and head weight. The effectiveness of the priming treatments are indexed to yields per unit area rather than each individual plant. The ability of the nonprimed seedlings to compensate for gaps, and thus "exploit" the reduced competition, coupled with a 14 h reduction in the MTE, and the lack of an impediment to emergence interacted to produce no significant difference in both the MTH and marketable yields (Table 3.7). Under suboptimal conditions such as temperature and soil crusting, however, the positive effects of seed priming will be observed.

Table 3.6. Field evaluation of matric- and osmotic-primed broccoli seeds.

Year	Treatment	T ₅₀ (emergence) (d)	Emergence (%)	T ₅₀ (harvest) (d)
1990	Osmotic primed	8.5	43.3	86
	Nonprimed	8.8	27.3	90
	<i>LSD</i> _(0.05)	9.9	17.9	2.2
1991	Matric primed	5.3	62.5	-
	Osmotic primed	5.5	64.3	-
	Nonprimed	6.2	65.5	-
	<i>LSD</i> _(0.05)	0.1	13.6	
1992	Matric Primed	5.1	77.0	88.2
	Osmotic Primed	5.3	76.8	88.9
	Nonprimed	5.7	66.8	95.3
	<i>LSD</i> _(0.05)	0.5	8.8	9.2

Table 3.7 Harvest variables of matric- and osmotic-primed broccoli seeds (1992).

Treatment	Head weight	Plant weight	Marketable	Yield
	(g)	(g)	(%)	(t·ha⁻¹)
Matric primed	161.7	448.2	60.9	7.8
Osmotic primed	160.5	438.8	61.5	7.9
Nonprimed	179.6	514.8	53.0	6.7
<i>LSD</i> _(0.05)	17.4	79.7	9.7	1.6

Literature Cited

- AOSA. 1983. Seed vigor testing handbook. *Association of Official Seed Analysts*, Springfield, Illinois, USA.
- Akers, S. W. and K. E. Holley and P. Ager. 1984. A screening process to establish effective priming treatments for vegetable seed. *HortScience* 19:211.
- Argerich, C. A. and K. J. Bradford. 1989. The effects of priming and ageing on seed vigour in tomato. *J. Exp. Bot.* 40:599-607.
- Alvarado, A. D., K. J. Bradford, and J. D. Hewitt. 1987. Osmotic priming of tomato seeds: effects on germination, field emergence, seedling growth, and fruit yield. *J. Amer. Soc. Hort. Sci.* 112:427-432.
- Bradford, K. J. 1986. Manipulation of seed water relations via osmotic priming to improve germination under stress conditions. *HortScience* 21:1105-1112.
- Dahal, P. and K. J. Bradford. 1990. Effects of priming and endosperm integrity on seed germination rates of tomato genotypes. II. Germination at reduced water potential. *J. Exp. Bot.* 41:1431-1439.
- Ellis, R. H. and P. D. Butcher. 1988. The effects of priming and 'natural' differences in quality amongst onion seed lots on the response of the rate of germination to temperature and the identification of the characteristics under genotypic control. *J. Exp. Bot.* 39:935-950.
- Ellis, R. H., S. Covell, E. H. Roberts and R. J. Summerfield. 1986. The influence of temperature on seed germination rate in grain legumes. II. Intraspecific variation in chickpea (*Cicer arietinum* L.) at constant temperatures. *J. Exp. Bot.* 39:935-950.

- Elson, M. K., R. D. Morse, D. D. Wolf, and D. H. Vaughn. 1992. High temperature inhibition of seed germination and seedling emergence of broccoli. *HortTechnol.* 3:417-419.
- Finch-Savage, W. E. 1986. A study of the relationship between seedling characters and rate of germination within a seedlot. *Ann. Appl. Biol.* 108:441-444.
- Gray, D. 1978. The establishment of lettuce at high soil temperatures. *Acta Horticultrae* 72:33-37.
- Gray, D. 1976. The effect of time to emergence on head weight and variation in head weight at maturity in lettuce (*Lactuca sativa*). *Ann. Appl. Biol.* 82:569-575.
- Heather, D. W. and J. B. Sieczka. 1991. Effect of seed size and cultivar on emergence and stand establishment of broccoli in crusted soil. *J. Amer. Soc. Hort. Sci.* 116:946-949.
- Heydecker, W. and P. Coolbear. 1977. Seed treatments for improved performance. Survey and attempted prognosis. *Seed Sci. Technol.* 5:353-425.
- International Seed Testing Association. 1985. International rules for seed testing. *Seed Sci. Technol.* 13:299-520.
- Jett, L. W., R. D. Morse and C. R. O'Dell. 1995. Plant density effects on production of single-head broccoli. *HortScience* 30(2).
- Khan, A. A., N. H. Peck, and C. Samimy. 1981. Seed osmoconditioning: physiological and biochemical changes. *Israel J. Bot.* 29:133-144.
- Khan, A. A., H. Miura, J. Prusinska, and S. Ilyas. 1990. Matricconditioning of seeds to improve performance. pp. 19-40. In: *Proc. Natl. Symp. Stand Establishment. Hort. Crops*, Minneapolis, MN.
- Khan, A. A. 1992. Preplant physiological seed conditioning. *Hortic. Rev.* 51:53-76.

- Mexal, J., J. T. Fisher, J. Osteryoung, and C. P. Patrick Reid. 1975. Oxygen availability in polyethylene glycol solutions and its implications in plant-water relations. *Plant Physiol.* 55:20-24.
- Michel, B. E. 1983. Evaluation of the water potentials of solutions of polyethylene glycol 8000 both in the absence and presence of other solutes. *Plant Physiol.* 72:66-70.
- McCormack, A. C. and P. D. Keefe. 1990. A modified slant board test for vigour testing *Brassicas*. *Plants, Varieties, and Seeds* 3:81-87.
- Mobayen, R. G. and F. L. Milthorpe. 1978. Citrus seed germination as influenced by water potential and salinity. *Proc. Intl. Soc. Citriculture* 1:247-249.
- Parera, C. A. and D. J. Cantliffe. 1992. Enhanced emergence and seedling vigor in *shrunken-2* sweet corn via seed disinfection and solid matrix priming. *J. Amer. Soc. Hort. Sci.* 117:400-403.
- Pill, W. G., T. A. Evans and P. Krishnan. 1994. Priming improves germination and emergence of combine-harvested *Amaranthus cruentus* L. seeds. *HortScience* 29:655-658.
- Radford, P. J. 1967. Growth analysis formulae- their use and abuse. *Crop Sci.* 7:171-175.
- Rao, S. C., S. W. Akers and R. M. Ahring. 1987. Priming *Brassica* seed to improve emergence under different temperatures and soil moisture conditions. *Crop Sci.* 27:1050-1053.
- Røeggen, O. 1986. Calculation of the minimum germination temperature of vegetable species in the brassicaceae. *Meldinger fra Norgews landbrukshøgskole* 65:1-6.

- Raison, J. K. 1985. Alterations in the physical properties and thermal response of membrane lipids: correlations with acclimation to chilling and high temperature. In: *Frontiers of Membrane Research in Agriculture*. pp. 383-401. (J. B. St. John, E. Berlin, and P. C. Jackson, eds.), Rowman & Allanheld Totowa, NJ.
- Salter, P. J., I. E. Currah, and J. R. Fellows. 1981. Studies on some sources of variation in carrot root weight. *J. Agr. Sci. (Cambridge)* 96:549-555.
- Schroth, M. N. and R. J. Cook. 1964. Electrolyte leakage and damping-off of bean. *Phytopathology* 12:33-37.
- Scott, S. J. and R. A. Jones, 1985a. Cold tolerance in tomato. 1. Seed germination and early seedling growth of *Lycopersicon esculentum*. *Physiologia Plantarum* 65:487-492.
- Sterrett, S. B., J. W. Mapp and C. W. Coale. 1990. Feasibility of broccóli as a new enterprise - a systems approach. *HortScience* 25:638-641.
- TeKrony D. and K. Egli. 1991. Review of seed vigor and crop yield. *Crop Sci.* 31:816-822.
- Welbaum, G. E. and K. J. Bradford. 1991. Water relations of seed development and germination in muskmelon (*Cucumis melo* L.). VI. Influence of priming on germination responses to temperature and water potential during seed development. *J. Exp. Bot.* 42:393-399.
- Wilson, R. E., E. H. Jensen, and G. C. J. Fernandez. 1992. Seed germination response for eleven forage cultivars of *Brassica* to temperature. *Agron. J.* 84:200-202.
- Wurr J. and J. R. Fellows 1983. The effect of the time of seedling emergence of crisp lettuce on the time of maturity and head weight at maturity. *J. Hortic. Sci.* 58:561-566.

Chapter 4

The Effects of Seed Priming on Physical Characteristics of Broccoli Seeds

Abstract. Priming (controlled hydration followed by redrying) increases the vigor of broccoli seeds. The physiology of the priming mechanism is not well understood. The physical characteristics of broccoli seeds were examined using both light and environmental scanning electron microscopy (ESEM) after priming and during germination to determine how the radicle emerges from the intact seed. An Instron Universal Testing Machine was used to measure the restrictive force of the testa. The majority of broccoli seeds germinated by direct penetration through the testa (i.e. no prehydration splitting $\approx 23^\circ$ from the funiculus). Priming increased seed volume (32%) without increasing embryo size resulting in free spaces between the embryo and testa, and ESEM revealed that priming stretched the testa resulting in a marked increase in cell size. Also, with some seeds, minute cracking was observed after priming in proximity to the area where the radicle emerges. The testa of broccoli seeds was a barrier to germination and represented a restrictive force, expressed as the testa yield threshold (Y_T) of 0.5 MPa. Primed seeds, however, did not germinate at a lower water potential (Ψ), indicating that at the time of radical protrusion, there may be no difference in the restrictive force of the testa between primed and nonprimed seeds. The Instron analysis indicated that dry (6% moisture content, dw. basis) primed seeds had weaker testae than dry, nonprimed seeds; but immediately before radicle protrusion, there was no detectable difference in testa integrity. The major effect of priming was to maintain a lower hydrotime constant (θ_H) at each Ψ relative to nonprimed seeds, without lowering the base Ψ (Ψ_b) which allowed

primed seeds to make a greater progression towards germination per unit MPa. It was further hypothesized that the yield threshold (Y) of primed seeds is reduced by Y_T , perhaps explaining the increased germination rate of primed seeds.

Introduction

Seed priming is a controlled hydration procedure followed by redrying in which seeds go through the initial phases of germination without radical growth. Primed seeds, when reimbibed, exhibit significantly enhanced seed vigor compared to nonprimed seeds. The physiology of the priming mechanism that produces enhanced seed vigor of *Brassica* spp. is not known. The most effective priming treatment is determined empirically for each seed species, and the reported effects of priming on seeds seem to parallel the diversity of priming treatments (Bradford, 1986). Germination enhancement of several primed vegetable seeds has been shown to be related to metabolic repair processes (Bray et al., 1989; Burgass and Powell, 1984), a buildup of germination metabolites (Khan et al., 1978; Coolbear et al., 1980), and even osmotic adjustment (Bradford, 1986). Haigh (1988), however, found only a small decrease in the osmotic potential and no increase in the turgor of the embryo during priming of tomato (*Lycopersicon esculentum* Mill.) seeds.

Priming treatments have been shown to advance developmental processes in some seed species such as celery (*Apium graveolens* L.) and muskmelon (*Cucumis melo* L.) and remove thermodormancy in lettuce (*Lactuca sativa* L.) seeds (Heydecker and Coolbear, 1977; Perkins-Veazie and Cantliffe, 1984; Weibe and Tiessen, 1979; van der Toorn, 1989; Welbaum and Bradford, 1991). Physiological and biochemical changes that occur during priming allow seeds to develop a high germination potential (i.e. increased turgor) or the ability of the emerging radicle to overcome a possible testa restraint (Khan, 1992). The

length of time required for germination of *Brassica* spp. seeds may be related to the time it takes a possible mechanical barrier yield threshold to fall below embryo turgor (Bradford, 1990). Mechanical barriers such as the endosperm, perisperm, or testa limit radicle emergence in many types of seeds (Bradford, 1990; Groot and Karssen, 1987; Hegarty and Ross, 1980; Ikuma and Thimann, 1963; Liptay and Schopfer, 1983; Watkins and Cantliffe, 1983). Dahal and Bradford (1990) discovered that removing the endosperm or testa cap of tomato seeds which have an embryo encased by an endosperm, increased the germination rate and lowered the Ψ required to inhibit germination by 0.7 to 0.9 MPa. Furthermore, priming increased the rate of germination at all Ψ 's above the base water potential (Ψ_b), defined as the minimum Ψ allowing germination, but did not lower the Ψ_b .

Gummerson (1986) developed a model to describe seed germination response to Ψ . It was proposed that the time to germination of a given percentage of seeds imbibed at a particular Ψ is related to two parameters, the base water potential of the seeds in the population (Ψ_b), and the hydrotime constant (θ_H) expressed in MPa·h (Bradford, 1990; Dahal and Bradford, 1990; Gummerson, 1986). These parameters are defined by the equation:

$$\theta_H = (\Psi - \Psi_b)t_g \quad (1)$$

where Ψ is the water potential of the imbibition medium, Ψ_b is the base water potential, and t_g is the time to germination (Ni and Bradford, 1992). The equation states that if θ_H is constant, the increase in the time to germination as the Ψ is reduced is inversely proportional to the difference between Ψ and Ψ_b .

Bradford (1990) extended this model and adapted it to the Lockhart model for plant cell growth which is written as $dV/Vdt = m(\psi_p - Y)$ where dV/Vdt is the rate of volume

increase relative to the total volume, m is the extensibility coefficient relating growth rate to ψ_p (turgor pressure), and Y is the minimum or threshold turgor that must be exceeded for growth to occur. Expressed in terms of germination rate, the model becomes $GR = 1/t = (\Psi - \Psi_b)/\theta_H$, where t is time to germination of a certain percentage of the seed lot, Ψ is the water potential of the imbibition medium, Ψ_b is the minimum water potential allowing germination, and θ_H is the hydrotime constant expressed in MPa·h. A plot of $1/t_g$ versus Ψ should be linear, with the intercept at $1/t_g = 0$ equal to Ψ_b and a slope of $1/\theta_H$. The variable $1/\theta_H$ is equivalent to the extensibility coefficient m in the Lockhart model, while the Ψ_b is related to the yield threshold (Y). In seeds that possess constraining tissue, the yield threshold is the sum of the yield threshold of the embryonic axes cells (Y_e) and the restraining tissue. Germination rate would be increased if the θ_H and (or) if the Ψ_b is lowered.

Broccoli (*Brassica oleracea* var. *italica* Plenck) seeds consist of an embryo and the surrounding testa (Figure 4.1). The testa is derived from two integuments and a layer of cells next to the embryo which are all that remain of the nucellar tissue. The outer coat of the seed consists of an epidermis and two layers of subepidermal tissue which is derived from the outer integuments (Thompson, 1933). The testa of *B. oleracea* is reticulated and composed of thick-walled epidermal cells (Vaughn and Whitehouse, 1971). Since the testa absorbs a fixed amount of expansive force from the embryo, modifications in the integrity of the testa could alter germination performance. Removal of the testa of a related member of the family Brassicaceae, radish (*Raphanus sativus* L.), resulted in a significant increase in the germination rate (Schopfer and Plachy, 1993). Liou (1987), working with cabbage (*Brassica oleracea* L. var. *capitata*) seeds, hypothesized that the faster rate of imbibition and radical growth observed with osmotically-primed seeds was related to a priming-induced change in some internal or external seed structures such as

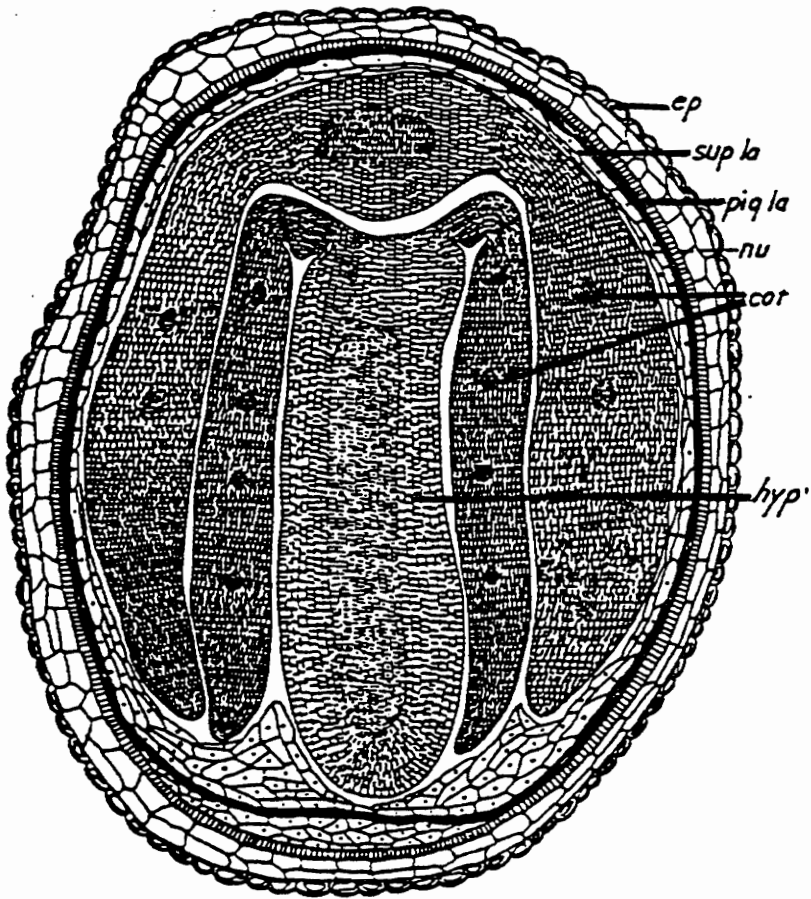

Figure 4.1. Schematic of mature *Brassica* spp. seed. *ep*: epidermis; *sup la*: sub-epidermal layer; *pig la*: pigmented layer; *nu*: nucellar layer; *cor*: cotyledons; *hyp*: hypocotyl. Adapted and reprinted from Thompson (1933).

the testa. Schopfer and Plachy (1987), reported that the testa of rape (*Brassica napus* L.) seeds splits during imbibition and thus is not a barrier to germination, which was defined as protrusion of the radicle by ≥ 2 mm. McCormac and Keefe (1990) observed that intact testa of cauliflower (*Brassica oleracea* L. var. *botrytis*) seeds are capable of limiting the rate of water influx into the seed. It was hypothesized that one of the positive effects of priming was to allow germination of *Brassica* spp. seeds at low temperatures of imbibition, since priming allowed imbibition to occur under more optimal conditions.

Argerich and Bradford (1989) observed a 36% increase in volume of dried, primed tomato seeds compared to nonprimed seeds as a result of "free spaces" that formed around the embryo. It was hypothesized that the free spaces allowed greater water uptake by the embryo and higher turgor pressure, resulting in more rapid growth and penetration of the endosperm by the radicle.

Primed broccoli seeds consistently germinate and emerge faster under a wide range of laboratory and field conditions (cf. chapters 1 and 2). There is no prior research that attempts to explain how and why priming accelerates broccoli seed germination. The objective of this research was to investigate the effects of priming on physical characteristics of broccoli seeds to determine if such changes are responsible for the improved seed vigor that is consistently observed with primed broccoli seeds.

Materials and Methods

Seed material and priming treatments. Seeds of cvs. 'Brigadier' and 'Packman' (PetoSeed Co., Saticoy, CA) were primed by an osmotic technique with polyethylene glycol 8000 (PEG; Fisher Scientific Co., Fair Lawn, NJ). For osmotic priming, PEG ($7 \text{ ml}\cdot\text{g}^{-1}$ seed) was added to two thicknesses of filter paper (Whatman no. 1) in covered 8.5 cm^2 petri dishes and sealed with parafilm (American National Can, Greenwich, Conn.) to prevent

evaporation. The PEG solutions had a $\Psi = -1.2$ MPa (0.45 M) (Michel, 1980) verified with a vapor pressure osmometer (model 5500, Wescor Inc., Logan, UT) calibrated with salt solutions of known Ψ s. Priming was performed at 20°C in a dark incubator. After 7 d, the primed seeds were removed from the osmoticum, vigorously rinsed for 2 min in tap water, and forced-air dried (37°C) for ≈ 20 min, and placed in a silica gel desiccator (40% RH) for 7 to 10 d until a final moisture content of 5 to 6% (dw. basis) was reached (ISTA, 1986).

Characterization of germination events. Three replications containing ten seeds of primed and nonprimed seeds each were placed on germination blotters (Anchor Paper Co. Minneapolis, MN) and wetted with 12 ml of distilled water in petri dishes (8.5 cm² diameter) at 25°C. Seeds were examined under a dissecting microscope at 25-min intervals prior to radical protrusion to observe changes in the testa during germination.

Physical characteristics. After primed seeds were redried to their initial moisture content, changes in physical characteristics of primed and nonprimed seeds were examined. To determine if priming changed seed dry weight, embryos and testae were weighed before and after priming from 3 replications of 10 seeds each. The testae were softened by suspending seeds over 500 ml of distilled water for ≈ 4 h in a dark incubator at 20°C, and the testae were carefully removed with forceps. Seed diameter (intact seeds) was determined by using calipers (digimatic, Mitutoyo Corp., Tokyo, Japan) and measuring the seeds longitudinally from the point of vascular detachment, the funicular scar, before and after priming. Seed volume was determined by placing three replications of 100 seeds each, dried to a constant moisture content of 5 to 6%, in a 1 cm³ transparent tube, 6.5 mm in diameter. The height of the seeds in the column was recorded before and after priming. Transverse sections of primed and nonprimed seeds were prepared and stained with

toluidine blue prior to light microscopy to more accurately observe the specific seed tissues.

In another experiment, primed and nonprimed seeds were hydrated with 12 ml of distilled water, and at 15 min intervals, placed in a beaker filled with 250 ml of distilled water at room temperature (25°C). The number of floating and submerged seeds each time period was recorded to determine if altered physical characteristics changed seed density.

Environmental scanning electron microscopy (ESEM) (model E-3, Electroscan Corp., Wilmington, MA) was used to examine the testae of broccoli seeds before and after priming. ESEM, unlike conventional scanning, requires no sample preparation, and thus, seeds can be examined under a partial vacuum of 5 torr in water vapor before and after priming (Danilatos, 1983). Three replications of 4 seeds each were viewed before and after priming at $\times 150$ using the area near the funicular scar as a reference point for observation.

Effects of the testa on germination. Three replications of 10 primed and nonprimed broccoli seeds (cv. 'Brigadier') were decoated to directly determine if the testa is an impediment to germination of broccoli seeds. The seeds were examined for visible cracking before experimentation by viewing each replication under a dissecting microscope ($\times 10$). After removing the testae, all seeds were dried in a silica-gel desiccator (45% RH) for 7 d to 5 to 6% moisture content (dw. basis).

Imbibition time courses of intact and decoated primed and nonprimed seeds were determined by hydrating three replications of 10 seeds placed on germination blotters in 5-cm petri dishes and wetted with 4 ml of distilled water. At 1-h intervals, seeds were removed from dishes and immediately transferred to a humidified box (100% RH), where

surface moisture was removed by rolling the seeds on a semi-moist piece of filter paper and the seeds weighed.

Osmotic solutions using PEG were prepared in 0.2 MPa increments from 0 to -1.2 MPa. Decoated and intact, primed and nonprimed seeds were placed on blotter paper in 5-cm petri dishes saturated with 4 ml of PEG at 25°C, and germination (visible radical protrusion) was recorded at 2-h intervals. Fresh osmotica (1 ml) was added daily to maintain a constant Ψ .

Instron analysis. Instron analysis was performed using an Instron Universal Testing Machine (model 1123, Instron Engineering Corp., Canton, MA) to measure the force and energy required to penetrate the testa of primed and nonprimed broccoli seeds (Figure 4.2). Primed and nonprimed seeds were tested at 0, 1.5, and 14.5 h after imbibition, which correlated in time with dry seeds and 1 h prior to germination of primed and nonprimed seeds, respectively. Seeds were hydrated on two thicknesses of blotter paper saturated with 12 ml distilled water in 8.5-cm petri dishes at 25°C.

Broccoli seeds were mounted in a wooden holder placed on a 20 N load cell of the Instron Universal Testing Machine. A tapered steel needle with a tip diameter approximating the size of the radical (0.23 mm) was attached to the crosshead of the Instron. The needle was aligned near the area where the radicle had been observed to penetrate the testa, and allowed to penetrate the entire seed. A hole through the center of the sample holder allowed the needle to advance through the seed at a rate of 5 mm min⁻¹ without any further resistance.

Statistical analysis. Mean time to germination (MTG) was calculated by plotting cumulative germination probit versus log (base 10) time. Mean germination rate (MGR) was calculated as the inverse of MTG. The Ψ that inhibited 50% germination (Ψ_{50}), was calculated by plotting cumulative germination percentage versus Ψ , and the base Ψ (Ψ_b),

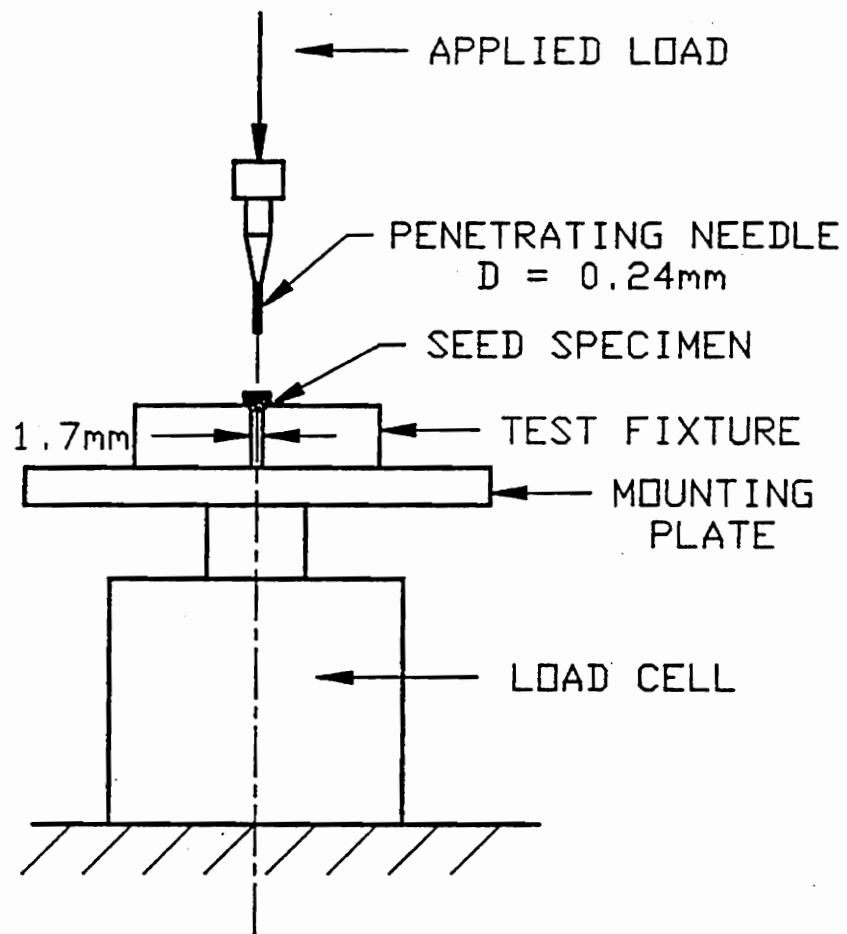

Figure 4.2. The Instron Universal Testing Machine. The load cell sensed the force applied as a 0.23 mm needle penetrated the intact broccoli seed which was immobilized in a wooden sample holder.

was determined by plotting MGR versus Ψ according to Gummerson's hydrotime model. Analysis of variance was performed on the antilog MTG values and physical attributes to determine significant differences among treatments (Costat, CoHort Software, Berkeley, CA).

Results and Discussion

Characteristics of broccoli seed germination. The radicle was observed to consistently emerge $\approx 23^\circ$ from the funicular scar in most broccoli seeds examined. In the majority of broccoli seeds (both primed and nonprimed), the radical protruded abruptly through the testa without any visible testa splitting (Figure 4.3). In primed seeds, there was no visible splitting of the testa before radical protrusion. Approximately 35% of nonprimed seeds did exhibit some degree of splitting before radicle emergence. The longest length of time observed between splitting and radicle protrusion was 60 min.

During the initial phase of germination (≈ 2 h), imbibition of water occurs, and the broccoli seed swells (Figure 4.3 A). After approximately 5 h (for primed seeds) and 16 h (for nonprimed seeds), abrupt testa splitting was observed immediately in front of the expanding radical (Figure 4.3 B), followed by immediate penetration (Table 4.1; Figure 4.3 C).

Physical changes induced by priming. Priming induced ostensible changes to the external and internal appearance of broccoli seeds. Priming enlarged seeds and created a wrinkled exterior with crevices (Figure 4.4 A). Visual comparison of the interior anatomy of primed seeds indicated a significant change in the internal anatomy as a result of priming. In nonprimed seeds, the embryo and testa are tightly appressed with no significant crevices or spaces between tissues (Figure 4.4 B). After priming, the seeds were larger due to the formation of voids or "free spaces" which occurred near the radicle and the cotyledons

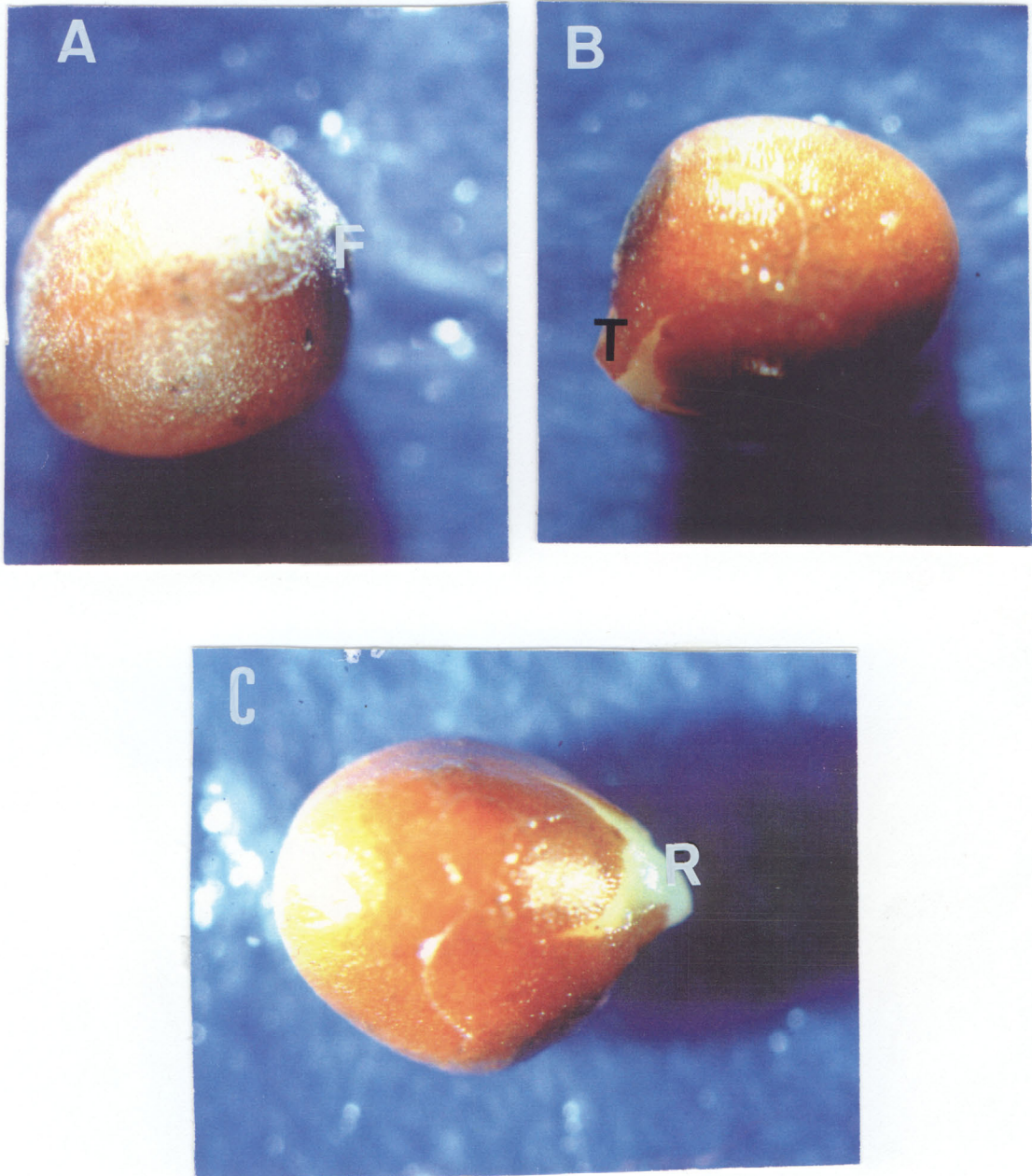

Figure 4.3. Chronology of broccoli seed germination (x25): **A).** Fully-hydrated seed. **B).** Splitting of the testa immediately in front of the radicle. **C).** Radicle protruding and abrupt (i.e. no prior splitting of testa) penetration of the radicle through the testa. Abbreviations: **F**=funicular scar; **R**=radicle **T**=testa.

Table 4.1. Observations of germination behavior of primed and nonprimed broccoli seeds.

Treatment	Observed abrupt penetration^z (%)	Observed splitting (within 15 minutes)^y %	Observed splitting (≥ 30 minutes) (%)
Control, nonprimed	65	24	11
Osmotic-Primed	100	-	-

^zAbrupt penetration of radicle without any prior splitting.

^yTime in which radical emerges after testa splits.

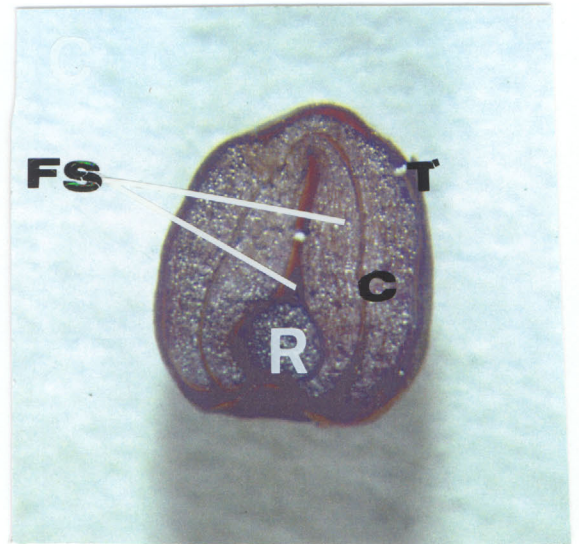
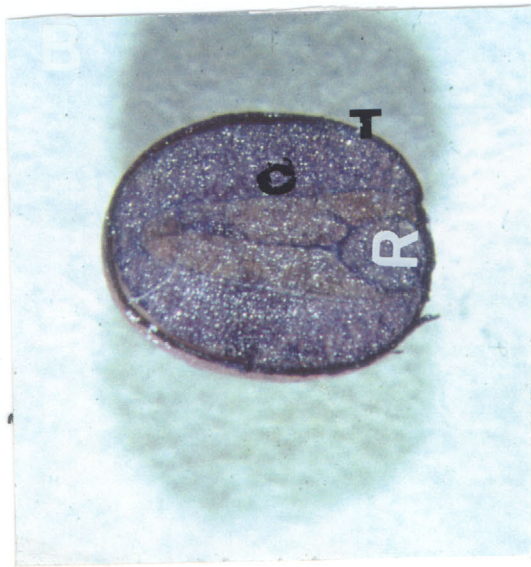
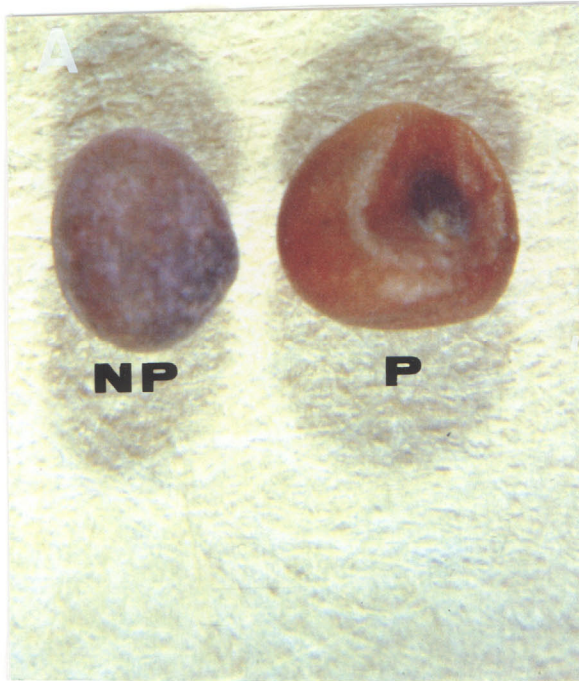

Figure 4.4. External and internal changes of broccoli seeds after priming (x25). **A).** Nonprimed and primed broccoli seeds. Exterior of broccoli seed shows a wrinkled testa with crevices after priming. Section of nonprimed **B)** and primed **C)** broccoli seed. Abbreviations: **P**=primed; **NP**=nonprimed; **R**=radicle; **C**=cotyledon(s); **FS**= free space(s); **T**=testa.

(Figure 4.4 C). The testa of primed seeds was not tightly appressed around the embryo as observed with the nonprimed seeds (Figure 4.4C). Priming significantly increased seed volume by 32% and significantly increased the physical diameter of broccoli seeds at the same dry weight. (Table 4.2). Priming did not change embryo or testae dry weight. Leopold (1983) observed that soybean (*Glycine max* L.) seeds did not return to their initial volume after hydration and redrying to their initial weight. Argerich and Bradford (1989) observed that priming did not result in any significant change in embryo diameter or dry weight.

The increase in seed diameter without a significant change in dry weight indicates that priming decreases seed density. This was supported by suspending primed and nonprimed seeds at 15 min intervals in distilled water. Nonprimed seeds, because of the lack of free spaces and, hence greater density, immediately sank to the bottom of the beaker. Primed seeds, however, continued to float for as long as 1 h before finally sinking to the bottom. It is unlikely that the free spaces retain trapped air. Since there is no significant difference in moisture content of primed and nonprimed seeds at full hydration, it is likely that the free spaces are eventually filled by the reexpanding and growing embryo.

Environmental scanning electron micrographs taken after priming showed discernible cracks, crevices, and separation of cells near the area where the radicle emerges that were not seen in nonprimed seeds (Figure 4.5 A and B). In addition to splitting, priming increased testa epidermal cell size (Figure 4.5). During the extended hydration period associated with priming, the testa swells in concert with the swelling embryo. The marked expansion in cell size indicates irreversible testa expansion.

Effects of the testa on germination. Removing the testa of primed and nonprimed seeds significantly increased the amount of water imbibed by the seed per unit time (Figure 4.6). Priming, however, did not result in a significant increase in the amount of water imbibed

Table 4.2. Characteristics of broccoli seeds before and after priming.

Treatment	Embryo dr. wt. (%)	Testa dr. wt (%)	Seed Diameter (mm)
Nonprimed	87.2	12.8	2.14
Primed	87.4	12.6	2.02
<i>LSD</i> _(0.05)	<i>NS</i>	<i>NS</i>	<i>0.09</i>

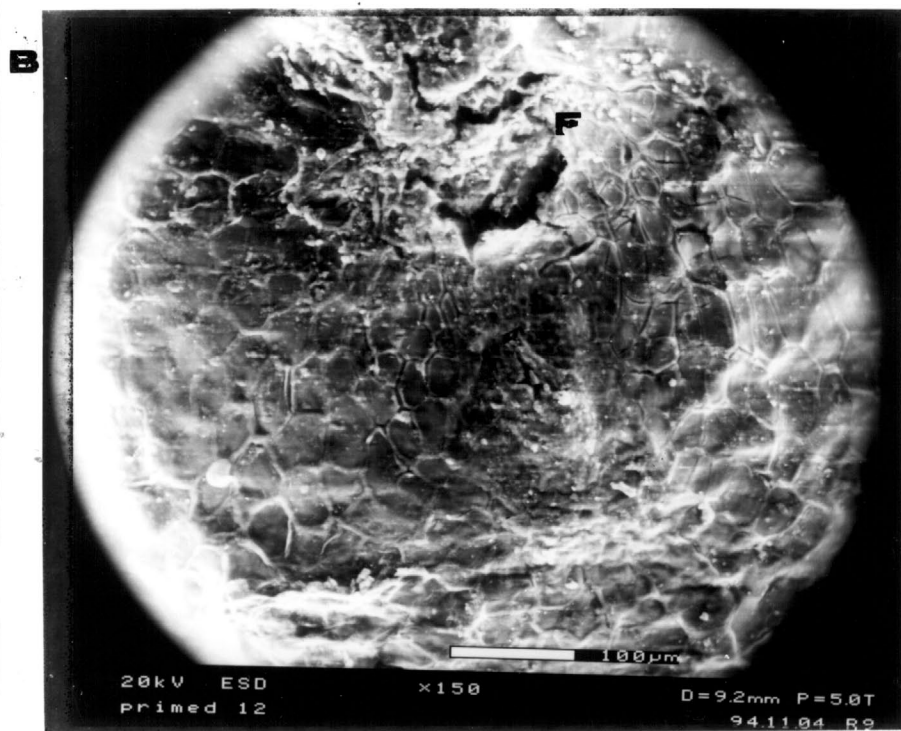
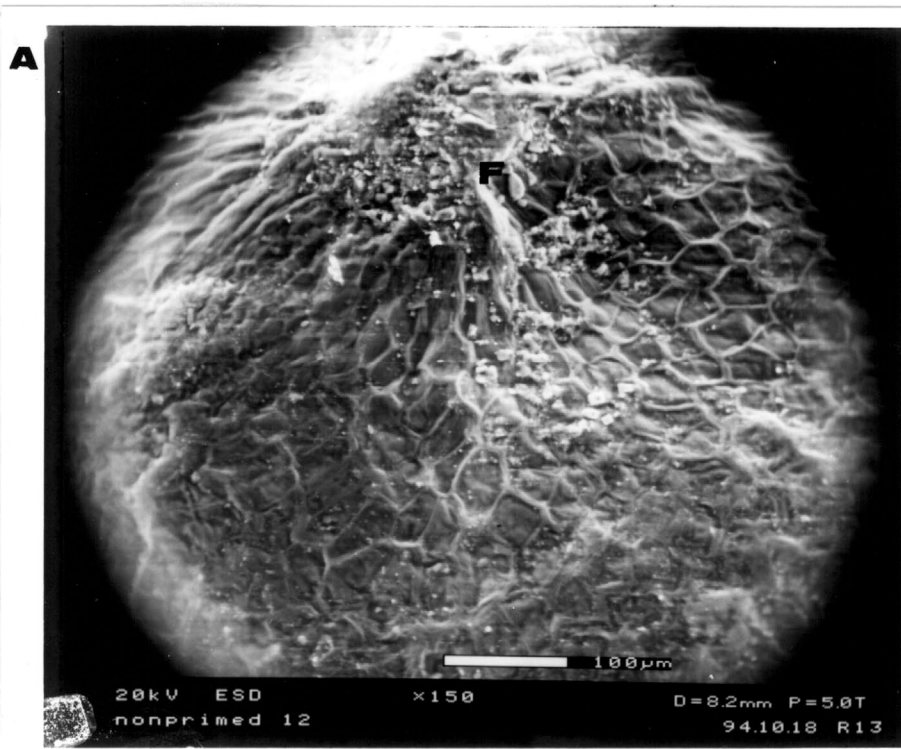

Figure 4.5. Environmental scanning electron micrograph of the testa of (A). nonprimed and (B). primed broccoli seeds (x150). F= funicular scar; E=epidermal cell. **Note:** Separation between epidermal cells.

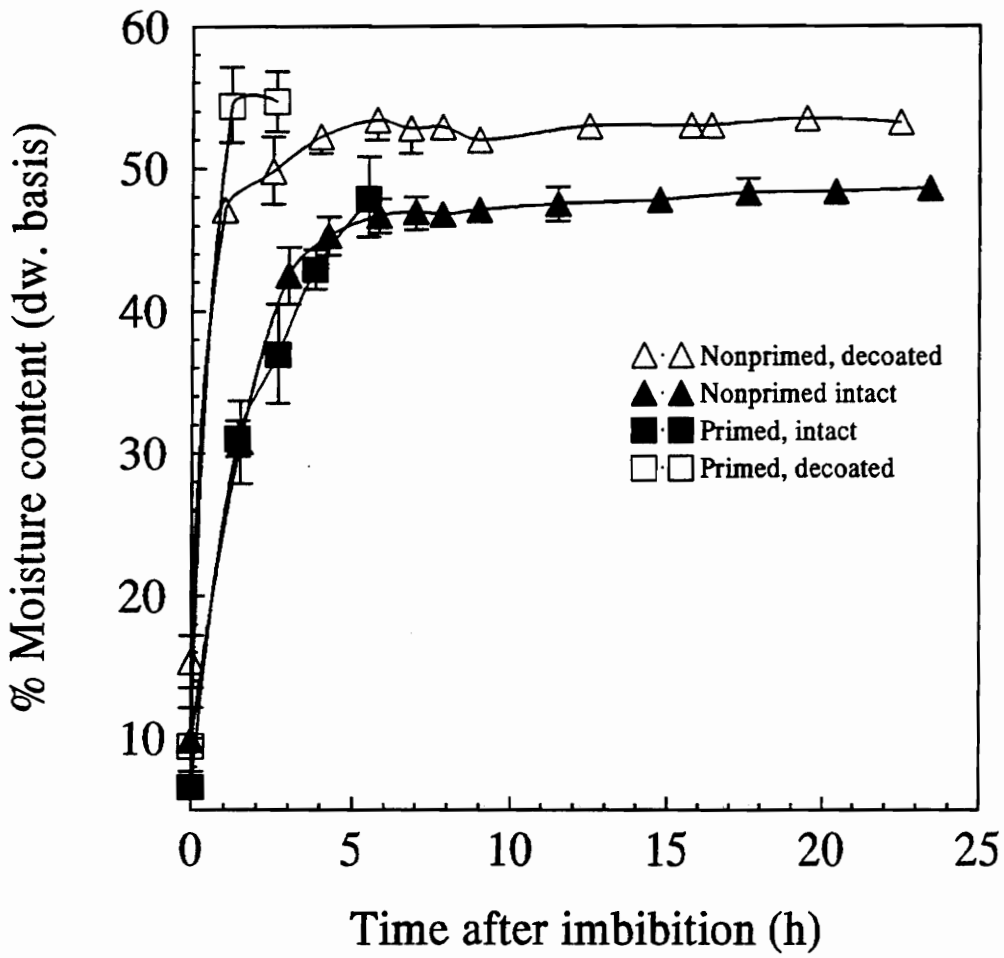

Figure 4.6. Imbibition time course for intact and decoated, primed and nonprimed seeds. Vertical bars represent the standard error of the means of 3 replications.

by the seed per unit time relative to nonprimed seeds. Primed seeds never exhibited any plateau in hydration, indicating that the seeds moved from imbibition immediately to expansive growth. At full hydration, the moisture content of both primed and nonprimed seeds was $\approx 46\%$ (dw. basis). Of the total moisture (% dw.) absorbed by the seed, the testa absorbs 7%, while the embryo accounts for the remaining 39%. Liou (1987) reported that 2 h after imbibition of primed cabbage seeds, the Ψ was equal to zero, but a period of transition between imbibition and expansive growth was not observed.

The water content of primed intact seeds, despite the observed significant increase in seed volume, was never significantly greater than nonprimed intact seeds. Mugnisjah (1987) reported a direct correlation between testa/embryo weight and final water uptake levels. Since no significant change in embryo/testa dry weight after priming was recorded, the embryos of intact seeds were not able to imbibe more water than the control nonprimed seeds. Liou (1987) also reported that there was no significant difference in seed moisture content at full hydration between osmotically primed and nonprimed cabbage seeds, but he did observe a faster rate of water uptake by primed seeds. In my study, the decoated primed and nonprimed seeds exhibited a significantly greater moisture content than intact primed and nonprimed seeds (Figure 4.6). The testa may function as a barrier that constrains embryo expansion or water influx.

Germination at reduced Ψ . Primed seeds had a significantly greater germination rate at all Ψ s examined compared to nonprimed seeds (Figure 4.7). In water, primed, intact seeds had a 60% higher MGR compared to nonprimed intact seeds (Table 4.3).

Removing the testa from primed seeds had a greater effect on MGR of primed seeds than on nonprimed seeds. At Ψ s less than -0.6 MPa, the percentage germination of decoated seeds was significantly greater than intact seeds (Figure 4.7). Intact, primed and decoated seeds failed to germinate at Ψ s less than -1.0 MPa. However, decoated, primed and

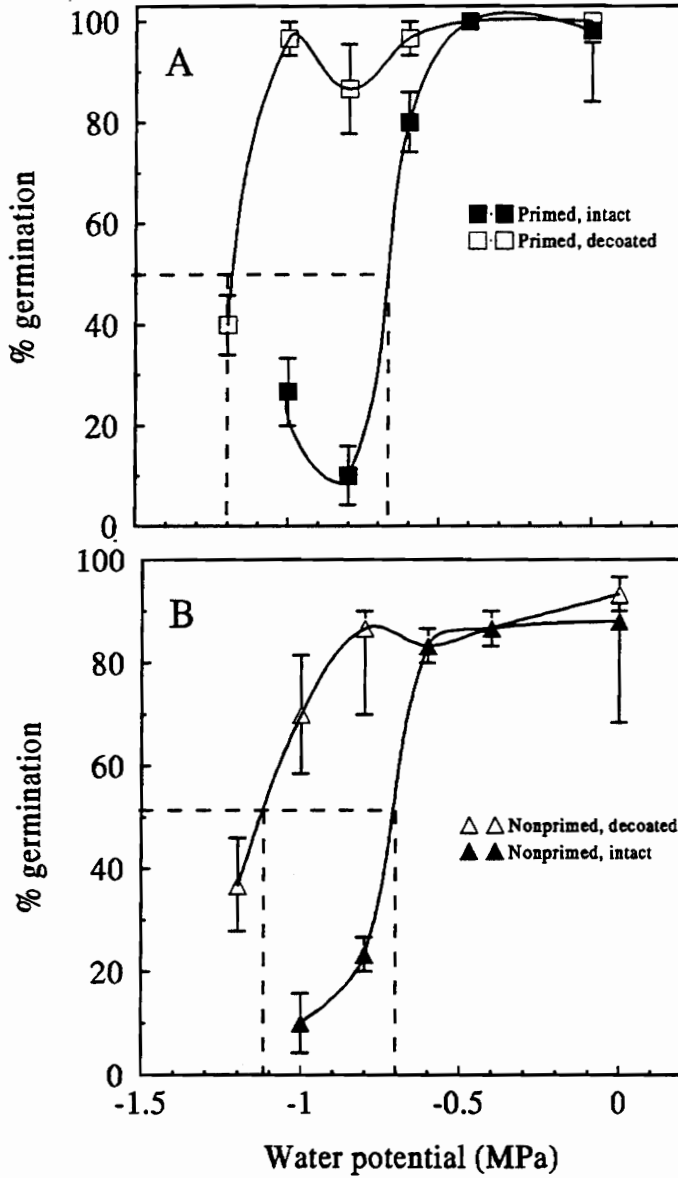

Figure 4.7. Cumulative germination versus water potential for (A). Primed, intact and decoated, and (B). Nonprimed, intact and decoated seeds. Dashed lines indicate the Ψ that inhibits 50% germination (Ψ_{50}).

Table 4.3. Base Ψ , hydrotime constant, and yield threshold of primed and nonprimed broccoli seeds.

The base Ψ (Ψ_b) is the Ψ where $GR = 0$. The Ψ_{50} is the Ψ that inhibits germination by 50%. The hydrotime constant (θ_H) is the progression towards germination per unit hydrotime, and the testa yield threshold (Y_t) is the difference in Ψ_{50} between intact and decoated seeds.

Treatment	Intact ^z	MGR (h ⁻¹ x 10)	θ_H (MPa.h)	Ψ_b (MPa)	Ψ_{50} (MPa)	Y_t (MPa)
Primed	+	0.99	11.6	-0.95	-0.65	-0.55
	-	2.05	10.9	-1.20	-1.20	
Nonprimed	+	0.39	27.1	-1.10	-0.70	-0.45
	-	0.43	22.9	-1.37	-1.15	

^z Intact and decoated seeds are represented by the symbol + and -, respectively.

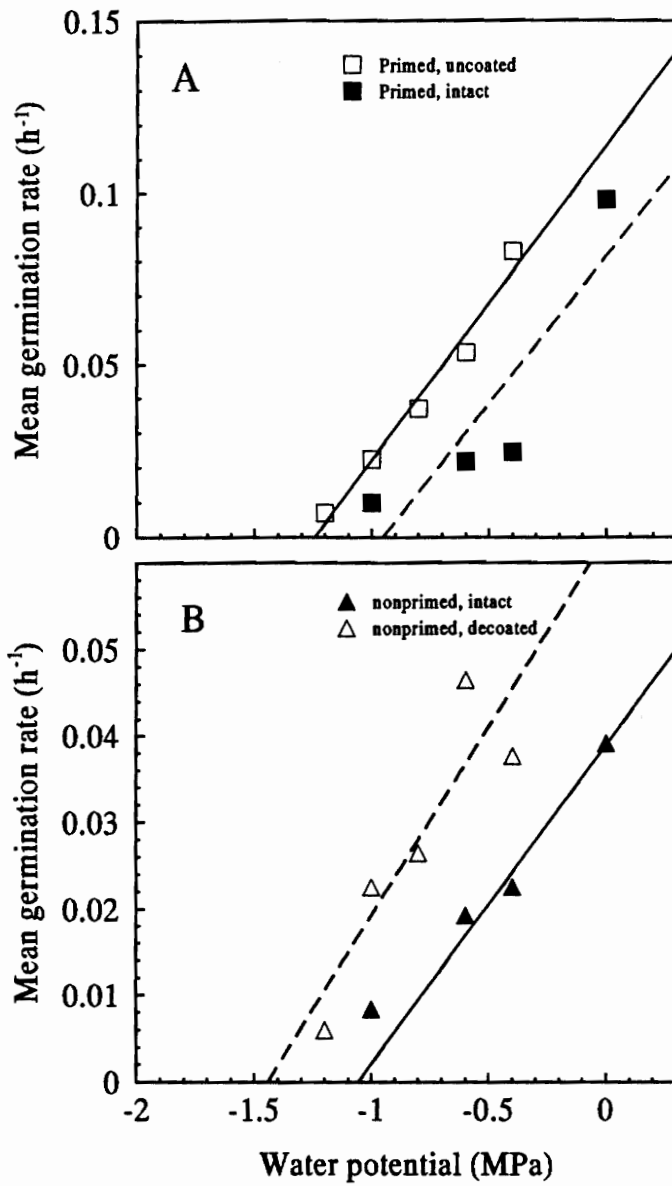

Figure 4.8. Mean germination rate versus water potential. The regression equations here are: primed, decoated: $y = -1.05 + 5.64x$ ($r^2=0.88$); primed, intact: $y = -0.85 + .1x$ ($r^2=0.78$); nonprimed decoated: $y = -1.04 + 26.5x$ ($r^2 = 0.98$); nonprimed, intact $y = -1.4 + 24.1x$ ($r^2 = 0.71$).

nonprimed seeds germinated at -1.2 MPa. The Ψ s required to inhibit germination by 50% (Ψ_{50}) were -0.65 and -0.70 MPa for intact, primed and nonprimed seeds, respectively (Table 4.3). The MGR model for calculating Ψ_b estimated the Ψ_b to equal -0.95 and -1.1 for primed and nonprimed seeds, respectively (Figure 4.8). The testa yield threshold (Y_t), as determined by subtracting the Ψ_{50} of intact and decoated seeds, was determined to be 0.55 and 0.45 MPa for primed and nonprimed seeds, respectively. Schopfer and Plachy (1993) reported the seed coat constraint of three radish cultivars to range from 0.31 to 0.61 MPa. The lack of a significant difference between the Ψ_{50} of intact and decoated seeds suggests that the testae were not an impediment to germination of primed seeds or nonprimed seeds.

The Instron load-deflection curve exhibited two peaks. The first (1) and second (2) peak represented the force required to penetrate the testa, and the entire seed, respectively (Figure 4.9). The penetration force was determined from the peak of the load-deflection curve (Welbaum et al., 1995).

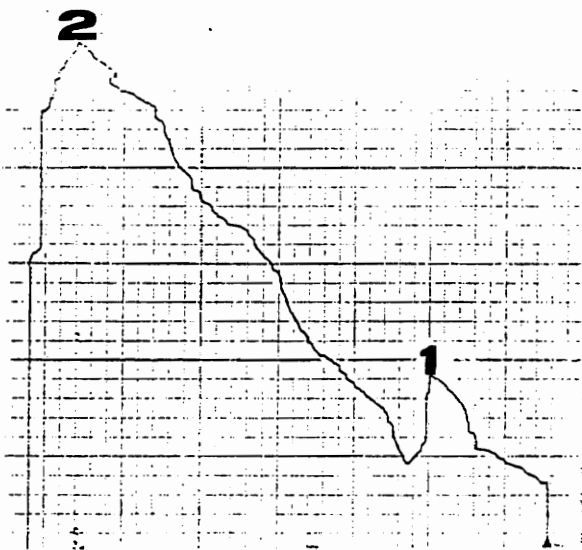

Figure 4.9. Representative Instron load-deflection curve.

Penetration of the seed with the Instron indicated that, at a seed moisture content of 5 to 6%, dried primed seeds had a weaker testa than nonprimed seeds (Figure 4.10).

However, as imbibition proceeded, the difference in testa resistance between primed and nonprimed seeds diminished. Just before germination (at 5 h for primed seeds and 14 h for nonprimed seeds), there was no significant difference in the force required to puncture the testa. This indicates that the testa is likely to be a barrier, but as observed with the decoated studies, there was no significant difference in the Ψ_b and hence, force between primed and nonprimed at the time of radicle protrusion. Dahal and Bradford (1990) reported no difference in the Ψ_b between primed and nonprimed tomato seeds; and, at the time of germination, no difference in the pressure required to push the embryos from the seeds was measured. It was concluded that priming increased the rate of endosperm weakening. In broccoli seeds, expansive growth commences immediately after imbibition. Since the testa constrains embryo expansion in broccoli seeds, the effect of priming may be to reduce the intensity of this external force, allowing greater embryo expansion per unit time.

The θ_H , represented by the inverse slope of GR versus Ψ , was constantly lower at all Ψ 's for primed versus nonprimed seeds (Table 4.3). Thus, priming did not increase the germination rate of broccoli seeds by lowering the Ψ_b , but rather by increasing the progression towards germination per unit MPa. Interestingly, removal of the testa of nonprimed seeds had a more significant impact on θ_H . Since primed seeds move from rapid imbibition to expansive growth, removal of the testa barrier allows greater embryo growth per unit time than removing the testa of nonprimed seeds. Nonprimed, decoated seeds still have to pass through a lag phase of water uptake that could last as long as 8 to 10 h at 25°C. Thus, removing the testa stimulates faster germination but does not increase the rate comparable to primed seeds.

Summary

Priming of broccoli seeds increases the rate of germination by decreasing the hydrotime constant (θ_H) and the testa yield threshold (Y_t) at a constant temperature. Since the hydrotime constant can be related to the extensibility coefficient of the Lockhart model of cell growth, this implies that primed broccoli seeds are able to make greater progress towards expansive growth at Ψ s above the Ψ_b relative to nonprimed seeds. Also, since the testa restrains embryo expansion and priming weakens the testa threshold, the total yield threshold (Y) for embryo growth may be lessened upon rehydration of primed seeds. Primed seeds would likely encounter less of an impediment per unit time, since the larger volume delays the time in which the embryo would become appressed to the testa.

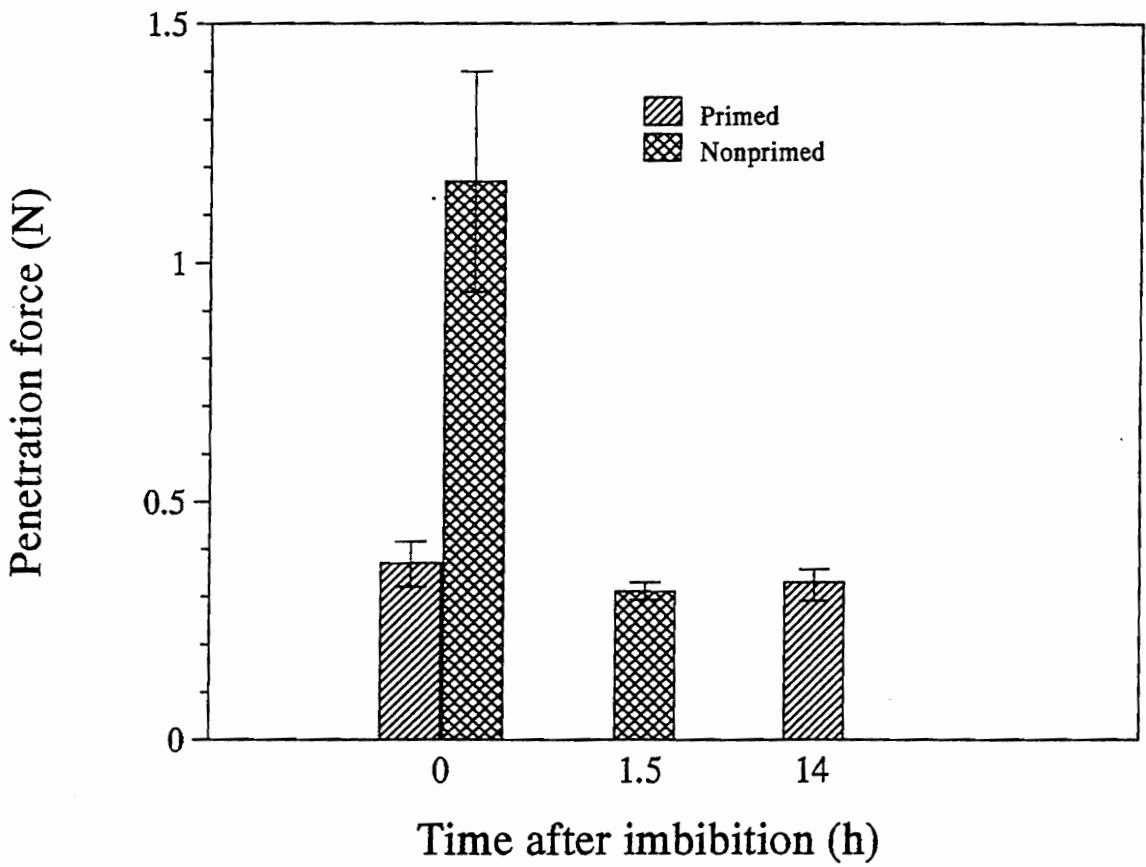

Figure 4.10. Penetration force (N) required to puncture the testa of primed and nonprimed broccoli seeds. Vertical bars represent the standard error of the means of 10 replications.

Literature Cited

- Argerich, C. A. and K. J. Bradford. 1989. The effects of priming and ageing on seed vigour in tomato. *J. Exp. Bot.* 40:599-607.
- Bradford, K. J. 1986. Manipulation of seed water relations via osmotic priming to improve germination under stress conditions. *HortScience* 21:1105-1112.
- Bray, C. M., P. A. Davison, M. Ashraf, and R. M. Taylor. Biochemical changes during osmopriming of leek seeds. *Ann. of Bot.* 63:185-193.
- Burgass, R. W. and A. A. Powell. 1984. Evidence for repair processes in the invigoration of seeds by hydration. *Ann. of Bot.* 53:75-757.
- Danilatos, G. D. 1983. A gaseous detector device for an environmental SEM. *Micron Microscopica Acta.* 14:307-319.
- Groot, S. P. C. and C. M. Karssen, 1987. Gibberellins regulate seed germination in tomato by endosperm weakening: a study with gibberellin-deficient mutants. *Planta* 171:525-531.
- Gummerson, R. J. 1986. The effect of constant temperatures and osmotic potential on the germination of sugar beet. *J. Exp. Bot.* 37:729-741.
- Haigh, A. H. 1988. Why do tomato seeds prime? Physiological investigations into the control of tomato seed germination and priming. *Ph.D. Dissertation*, Agricultural University, Wageningen, The Netherlands. 107 pp.
- Heydecker, W. and P. Coolbear. 1977. Seed treatments for improved performance-survey and attempted prognosis. *Seed Sci. Technol.* 5:353-425.
- International Seed Testing Association. 1986. International rules for seed testing. *Seed Sci. Technol.* 4:1-177.
- Liou, T. D. 1987. Studies on germination and vigour of cabbage seeds. *Ph.D. Dissertation*, Agricultural University, Wageningen, The Netherlands, pp 101.

- Liptay, A. and P. Schopfer. 1983. Effect of water stress, seed coat restraint, and abscisic acid upon different germination capabilities of two tomato lines at low temperature. *Plant Physiol.* 73:935-938.
- Michel, B. E., 1983. Evaluation of the water potentials of solutions of polyethylene glycol 8000 both in the absence and presence of other solutes *Plant Physiol.* 72:66-70.
- Ni, B. and K. J. Bradford. 1992. Quantitative models characterizing seed germination responses to abscisic acid and osmoticum. *Plant Physiol.* 98:1057-1068.
- Perkins-Veazie, P. and D. J. Cantliffe. 1984. Need for high-quality seed for effective priming to overcome thermodormancy in lettuce. *J. Amer. Soc. Hort. Sci.* 109:368-372.
- Schopfer, P. and C. Plachy. 1984. Control of seed germination by abscisic acid. II. Effect of embryo water uptake in *Brassica napus* L. *Plant Physiol.* 76:155-160.
- Schopfer, P. and C. Plachy. 1993. Photoinhibition of radish (*Raphanus sativus* L.) seed germination control of growth potential by cell-wall yielding in the embryo. *Plant, Cell and Environ.* 16:223-229.
- Thompson, R. C. 1933. A morphological study of flower and seed development in cabbage. *J. Agric. Res.* 47:215-232.
- van der Toorn, P. 1989. Embryo growth in mature celery seeds. *Ph.D. Dissertation*, Agricultural University, Wageningen, The Netherlands.
- Vaughan, J. G. and J. M. Whitehouse 1971. Seed structure and the taxonomy of the cruciferae. *Bot. J. Linn. Soc.* 64:383-409.
- Watkins J. R. and D. J. Cantliffe. 1983. Mechanical resistance of the seed coat and endosperm during germination of *Capsicum annuum* L. at low temperature. *Plant Physiol.* 72:146-150.

- Welbaum, G. E. and K. J. Bradford. 1991. Water relations of seed development and germination of muskmelon (*Cucumis melo* L.). VI. Influence of priming on germination responses to temperature and water potential during seed development. *J. Exp. Bot.* 42:393-399.
- Welbaum G. E., W. J. Muthui, J. H. Wilson, R. G. Grayson, and R. D. Fell. 1995. Weakening of muskmelon perisperm envelope tissue during germination. *J. Exp. Bot.* (submitted).
- Weibe, H. J. and T. H. Tiessen. 1979. Effects of different seed treatments on embryo growth and emergence of carrot seeds. *Gartenbauwissenschaft* 44:280-284.

Chapter 5

Water Relations of Primed Broccoli Seeds

Abstract. Reducing the time required for seed germination is desirable for production of many horticultural crops. Priming (controlled hydration followed by redrying) consistently improves the vigor of broccoli (*Brassica oleracea* var. *italica* Plenck) seeds as indexed by a faster rate of germination. The water relations associated with priming may provide information detailing how and why priming accelerates the germination of broccoli seeds. This research quantified the effect of priming by examining germination rate of seeds primed in polyethylene glycol (PEG 8000) at various water potentials (Ψ 's) ranging from -2.5 to -1.0 MPa. for 7 d at 20°C . Hydropriming time ($\text{MPa}\cdot\text{h}$) was derived by multiplying the duration of priming by the difference in Ψ between the priming osmoticum and the minimum Ψ that produced no priming effect (i.e. no enhancement in the rate of germination) (-2.5 MPa). Water uptake patterns of primed and nonprimed seeds were examined. Water potential isotherms of primed and nonprimed seeds were constructed to determine if priming altered basic seed water relations. Maximum germination rate was equated with the accumulation of ≈ 218 $\text{MPa}\cdot\text{h}$ (-1.2 MPa) and declined with decreasing Ψ . Priming of broccoli seeds eliminated the plateau phase of germination. There was a linear relationship between seed moisture content during priming and germination rate. The water potential isotherms indicated that priming did not induce any significant change in turgor of germinating broccoli seeds. The events that occur during the plateau phase of germination are fully conserved in primed broccoli seeds and are likely to be related exclusively to favorable changes in seed structural anatomy.

Introduction

Germination commences with the uptake of water. Germinating seeds typically exhibit a triphasic pattern of water uptake that starts with rapid imbibition (phase I), followed by a plateau phase in which there is little change in water content (phase II), and finally, an increase in water content coinciding with radical growth (phase III) (Bradford, 1986). During phase II, metabolic events and anatomical changes occur that prepare the seed for expansive growth, and thus, is the major control point for germination of nondormant seeds (Bradford, 1990). Factors which promote germination act by shortening phase II (Bradford, 1990).

Priming is a controlled hydration process followed by redrying that accelerates the rate of germination of many seed species (Khan, 1992). Priming entails incubating seeds at Ψ 's that are too low to permit expansive growth, or the duration of priming is shortened at a higher Ψ and concluded before phase III begins (Bradford, 1986). When primed seeds are reimbibed, they exhibit faster germination rates due in part to a significantly reduced phase II (Copeland and McDonald, 1985; Bewley and Black, 1994).

Despite the fact that priming controls the water status of seeds, very little is known about the water relations associated with priming. Bradford (1990) developed an alternative approach to applying growth models to seed germination by an extension of the hydrotime model proposed by Gummerson (1986) for analyzing seed germination in response to Ψ . One of the basic assumptions of Gummerson's model is that the rate of germination is proportional to the difference between the imbibition Ψ and the minimum Ψ allowing germination of a prescribed percentage (usually 50%) of a seed lot. The time required to achieve a "priming effect" can be expressed in terms of a hydrotime concept analogous to the thermal time or degree-days analysis of temperature responses (Bradford, 1990; Gummerson, 1986). Thus, the effectiveness of a given priming treatment is related

to the difference between the actual Ψ of the seed and a minimum Ψ required for [germination] to occur (Tarquis and Bradford, 1993).

In previous research (cf. chapter 4), I have observed anatomical and physical changes that were conserved upon redrying primed broccoli (*Brassica oleracea* var. *italica* Plenck) seeds. Primed broccoli seeds were observed to increase in volume by 32% with noticeable "free spaces" between the cotyledons and the radicle. Moreover, environmental scanning electron microscopy (ESEM) of the testa revealed marked separation and expansion of cells on the surface of the testa of primed seeds redried to their initial moisture content (cf. chapter 4). Argerich and Bradford (1989) also observed that priming and drying resulted in the development of free spaces between the embryo and endosperm that were not evident in primed seeds. Primed tomato seeds have a 20 to 25% greater volume than nonprimed seeds. Based on this physical change, it was hypothesized that the presence of free spaces might allow greater water uptake and greater turgor by the expanding embryo which is constrained by the endosperm, thus explaining the faster rate of germination of primed seeds.

The objectives of this research were to investigate the effectiveness of priming broccoli seeds at various Ψ 's for a fixed duration, and to determine if primed broccoli seeds exhibit altered water relations characteristics that may explain why priming accelerates the rate of germination.

Materials and Methods

Plant material and priming conditions. Broccoli (*Brassica oleracea* var. *italica* Plenck) seeds cv. 'Brigadier' (PetoSeed Co., Saticoy, CA) were osmotically primed in polyethylene glycol (Carbowax, PEG 8000, Fisher Scientific Co., Fairlawn, NJ) solutions of various osmolarities prepared according to Michel (1983) and verified with a vapor pressure

osmometer (model 5100C, Wescor Inc., Logan, UT). Seeds were placed on two thicknesses of germination blotter paper (Anchor Paper Co., St. Paul, Minn.) saturated with PEG ($\approx 7 \text{ ml}\cdot\text{g}^{-1}$) in 8.5 cm^2 petri dishes sealed with parafilm (American National Can, Greenwich, Conn.) to prevent evaporation and placed in a dark incubator at 20°C for 7 d.

Hydropriming time (θ), expressed as $\text{MPa}\cdot\text{h}$, was calculated as: $\text{MPa}\cdot\text{h} = (\Psi - \Psi_{min})t_p$ where Ψ is the Ψ of the priming medium, Ψ_{min} is the minimum Ψ at which a priming effect (improvement in germination rate) can be observed, and t_p is the priming duration (Tarquis and Bradford, 1993).

To test the effects of changing t_p , an experiment was conducted in which seeds were primed at a constant Ψ (-1.2 MPa) while t_p was varied from 0 to 240 h at 20°C .

To examine the effects of varying Ψ on the priming response of broccoli seeds, solutions of PEG were prepared as above in Ψ 's ranging from -2.6 to -1.0 MPa in 0.2 MPa increments and -2.5 MPa for 7 d at 20°C . To ensure that the Ψ values remained unchanged, fresh PEG solution (1 ml) was applied daily to the petri dishes for the first 3 d of the priming treatment. After priming, the seeds were removed from the PEG solutions by vigorously rinsing in tap water for 2 min followed by a 30 s rinse in 200 ml of distilled water. The seeds were blotted dry and forced-air dried (37°C) for 20 min. The seeds at each Ψ were sampled for moisture content after priming at 102°C for 17 h (ISTA, 1985). After initial drying, the primed seeds were dehydrated to 5 to 6% moisture content in a silica gel desiccator.

Imbibition rate. Three replications of 20 primed and nonprimed seeds were placed on germination blotters and wetted with 15 ml of distilled water in 8.5 cm^2 petri dishes. At 45-min intervals, seeds were removed from dishes, immediately transferred to a humidified box (100% RH), surface dried using semi-dry blotter paper, and weighed.

Germination tests. Germination was defined as visible radicle protrusion (≈ 1 mm). Three replications of 50 seeds each were placed on two germination blotters in 8.5 cm² diameter petri dishes saturated with 15 ml of distilled water at 25°C in a dark incubator. The petri dishes were wrapped in plastic to prevent evaporative water loss, and germination was scored every 4 h until no further germination was observed. Mean time to germination (MTG) was used to characterize the germination of broccoli seeds.

Statistical analysis. Cumulative germination percentages were plotted on a probit scale versus log time (t). Straight lines of approximately equal slope were produced for different Ψ 's, indicating a normal distribution of germination events with log time (data not shown). The log mean time to 50% germination (log t) was determined graphically as the intersection of the least squares regression line of the log (base 10) time versus probit germination percentage and 50% germination. The mean germination rate (MGR) was calculated as the inverse of log t. Germination percentages were arcsin transformed to normalize the variances of binomial data before ANOVA (CoStat, CoHort Software, Berkeley, CA) (Scott et al., 1984).

Water potential isotherms. Water potential isotherms were constructed by plotting measured Ψ versus relative water content (RWC) (Gross and Koch, 1991; Tyree and Jarvis, 1982; Welbaum and Meinzer, 1990). Water potential was calculated using a thermocouple psychrometer (model 85, J. R. D. Merrill, Logan, UT) calibrated with NaCl standards of known Ψ verified by osmometry. Four replications of 50 primed and nonprimed seeds each were hydrated on two blotters saturated with distilled water in 8.5 cm² petri dishes at 25°C. Primed seeds were hydrated for 4 h while nonprimed seeds were hydrated for 6 h to ensure both were fully hydrated. After the attainment of full hydration (i.e. $\Psi=0$), the seeds were transferred from the petri dishes to 1.1 cm³ psychrometer cups in a humidified box (100% RH) to prevent evaporative loss. The sample cups were

equilibrated for 4 h at 27°C in a water bath prior to taking the first measurement. After each reading, samples were weighed and dried on the lab bench for 15 min at room temperature (25°C) before incubation for an additional 4 h period. This procedure was done repeatedly over ≈ 72 h until an average of 10 to 11 Ψ values were obtained. The experiment was replicated twice with four replications per treatment. RWC was calculated by the equation:

$$RWC = \frac{\text{water content (dry wt. basis) of the sample} \times 100}{\text{water content (dry wt. basis) at full imbibition}} \quad (\text{Bradford, 1986})$$

One of the advantages of using a water potential isotherm is that it yields a weight-averaged value of the osmotic potential (ψ_{π}) of the undiluted cell sap (Tyree and Jarvis, 1982). The inverse of Ψ is plotted versus RWC. Where the data are linear, ψ_{π} is the only component of Ψ (Figure 5.1). Extrapolation of this line to RWC = 100 gives the value $1/\psi_{\pi}$ at full turgor. The difference between this extrapolated line at high Ψ and the actual value of $1/\Psi$ is equivalent to the turgor (ψ_p). When the osmotic line is extrapolated to RWC = 100, the RWC of the nonsymplastic water is calculated (Kramer, 1983; Tyree and Jarvis, 1983; Welbaum and Meinzer, 1990).

Results and Discussion

Changes in seed moisture. Nonprimed seeds exhibited a characteristic biphasic pattern of water uptake (Figure 5.2). Primed seeds, however, passed from phase I to phase III without a distinguishable plateau phase. There was no significant difference in water uptake per unit time or water content (dw. basis) between primed and nonprimed seeds, so the hydraulic conductivity of the seed tissue was not changed by priming. The length of the plateau phase of nonprimed seeds was ≈ 10 h at 25°C, which was two-thirds of the time required for germination to be completed. Primed seeds germinate ≈ 10 h earlier than

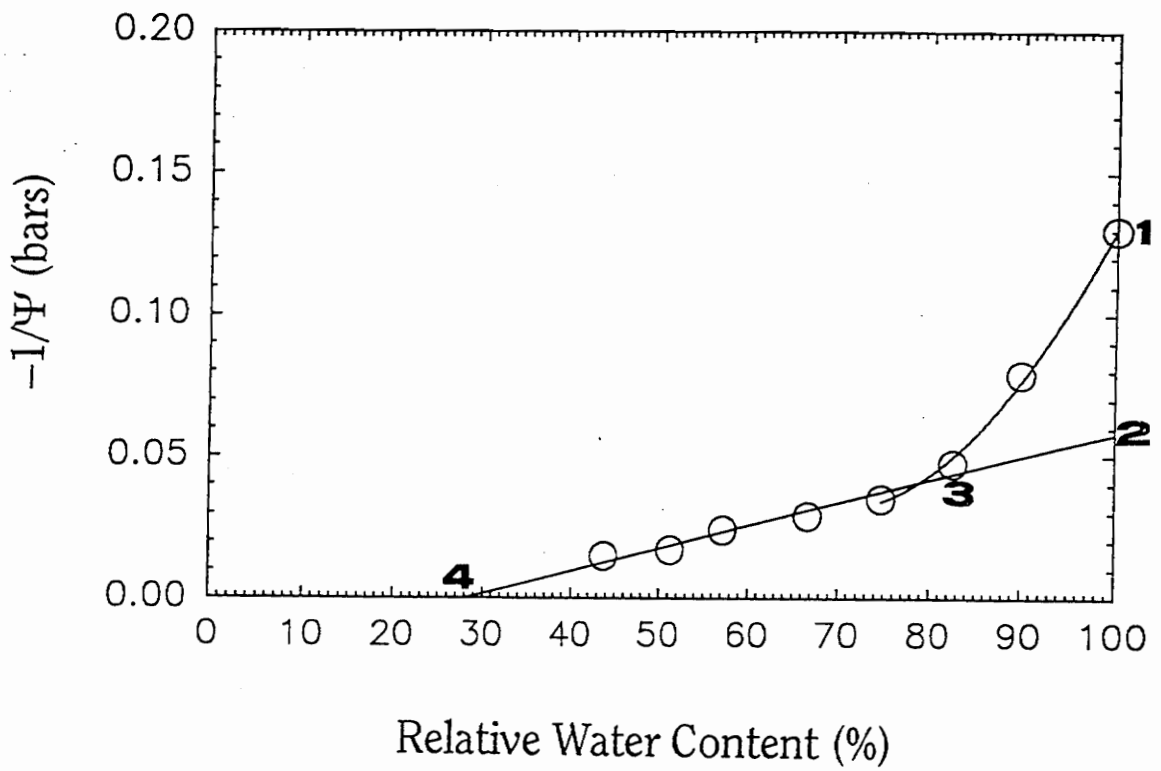

Figure 5.1. A characteristic water potential isotherm. Notation: 1) Ψ : Water potential at full hydration 2) ψ_{π} : Osmotic potential at full hydration; 3) Turgor loss point; 4) Apoplastic water content

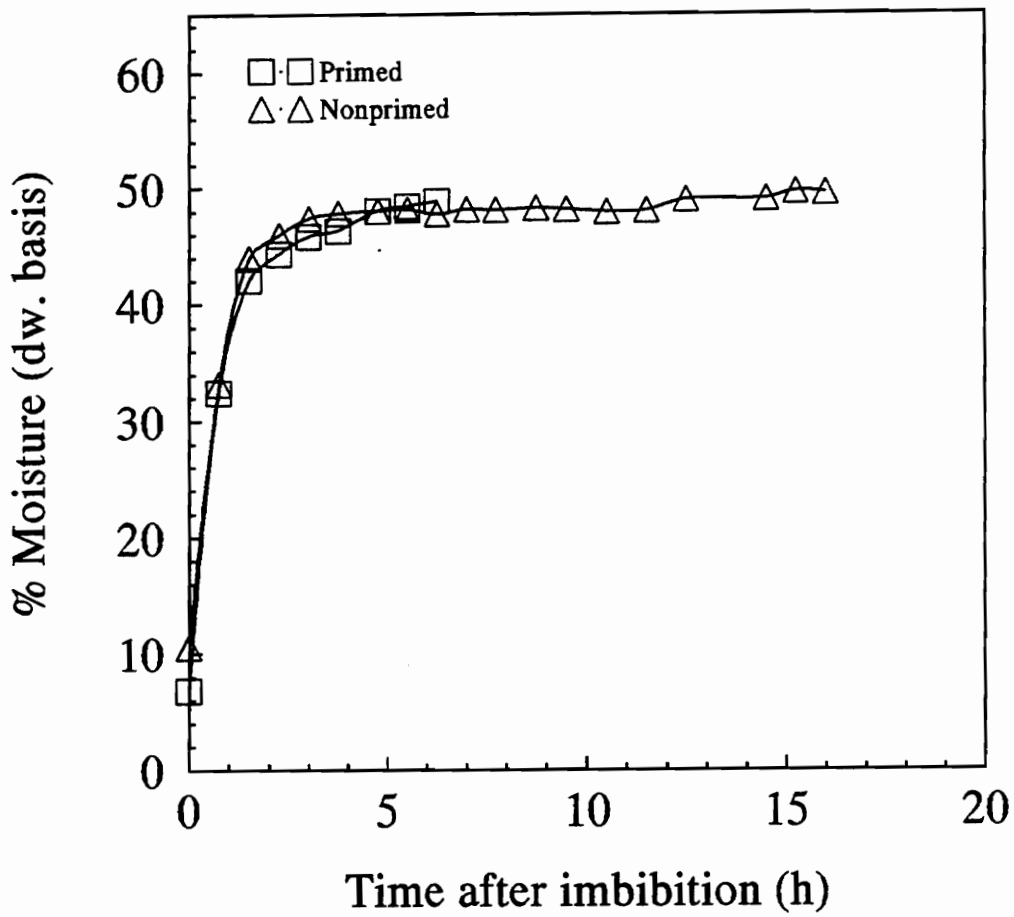

Figure 5.2. Imbibition time course of primed and nonprimed broccoli seeds at 25°C.

nonprimed seeds. Apparently, the metabolic and physical changes that occur during phase II are wholly conserved upon redrying and result in faster germination. The time lag between imbibition and radicle protrusion of primed seeds is limited by the time it takes for the seed (seed lot) to complete phase I.

Ψ effects on the priming response of seeds. At -1.0 MPa, germination was observed ($< 50\%$) after 4 d of priming, but no germination occurred at lower Ψ s. A significant enhancement in the germination rate was observed with seeds primed in Ψ s ranging from -2.4 to -1.0 MPa (Figure 5.3). Seeds primed at -2.5 MPa, however, did not significantly differ in germination rate with nonprimed seeds and seeds primed at -2.6 MPa had a lower germination rate than nonprimed seeds (0.013 versus 0.014 seeds \cdot h $^{-1}$, respectively).

Bradford (1986) observed no significant change in lettuce seed water content at Ψ s less than -2.0 MPa. Hegarty (1977) noted that calabrese (*Brassica oleracea* var. *italica*) seeds primed at -1.5 and -2.0 MPa reached a static equilibrium water content of 57 and 51%, respectively, and that level of hydration changed little during the priming treatment. Parera et al., (1992) reported that seed moisturizing (soaking in water followed by drying) could be used on celery (*Apium graveolens* L.) seeds to improve germination performance. Thus, a priming effect could be observed just by exposing seeds to the appropriate amount of water to reach a threshold moisture content.

The thermal time theory of seed germination states that germination rate of a seed lot is linear over a certain temperature range and is represented by the equation:

$1/t = (T - T_b) / \theta$, where t is the time to germination, θ is the thermal time to germination (expressed as $^{\circ}$ h), T is temperature during germination, and T_b is the intercept on the T axis. This theory can be modified to explain the effectiveness of a priming treatment (indexed by MGR) by substituting $(T - T_b)$ with $(\Psi - \Psi_{\min})$ and θ with t_p the duration the seeds are primed.

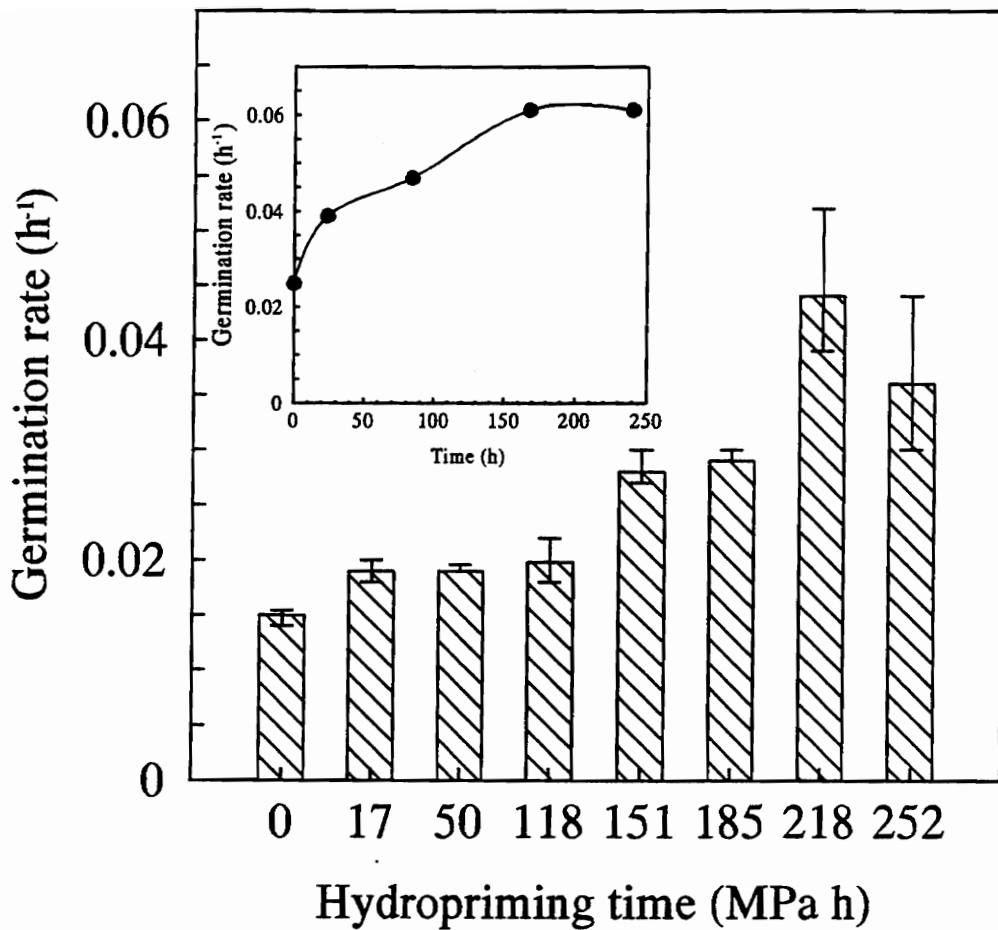

Figure 5.3. Germination rate as a function of hydropriming time (MPa·h) at Ψ 's ranging from -2.5 to -1.0 MPa and a fixed duration of priming (t_p). Vertical bars represent \pm standard error of three means per treatment. **Inset:** Germination rate of seeds primed at a constant Ψ while varying t_p .

The maximum MGR of broccoli seeds was attained after accumulation of 218 to 252 MPa·h, which correlated with Ψ s equal to -1.0 and -1.2 MPa, respectively. At -1.4 MPa (185 MPa·h), there was a significant reduction in the MGR which indicates that the metabolic or physical changes that occur during phase II are affected by Ψ (Figure 5.3). In order to observe any priming effect, a minimum of 17 MPa·h must be accumulated by broccoli seeds at 20°C . A short soak (6 to 7 h) of broccoli seeds at 0 Ψ results in the accumulation of ≈ 17 MPa·h and does improve the germination rate relative to nonprimed control seeds (0.019 versus 0.016 seeds h^{-1} , respectively). Increasing the duration of priming (t_p), increased the germination rate at a constant Ψ (Figure 5.3, inset). This further supports the hypothesis that the maximal priming effect is related to the accumulation of 218 MPa·h by broccoli seeds at 20°C . Accumulation of > 218 MPa·h resulted in no further priming enhancement. As seed moisture during priming decreased linearly from a high of 43% at -1.0 MPa, which resulted in partial germination, to 35.9% at -2.5 MPa, germination rate also declined (Figure 5.4). The threshold seed moisture content at Ψ_{\min} for a priming effect are $\approx 36\%$ and -2.5 MPa, respectively. Below this priming moisture content, there is no significant increase in the rate of germination. Welbaum (1993) observed a significant reduction in vigor of muskmelon seeds hydrated at Ψ s < -2.5 MPa, which was believed to be attributed to aging of the seeds at low Ψ s. Seeds age rapidly below a certain water content presumably because enzymatic repair processes cannot occur (Leopold and Vertucci, 1989). Thus -2.5 MPa may be the threshold Ψ , below which seed vigor declines or below which phase II processes cannot occur.

Changes in water relations of primed seeds. Analysis of Ψ isotherms of whole, primed and nonprimed broccoli seeds indicated that priming did not result in significant differences in the water relations of whole seeds. Primed seeds exhibited a larger

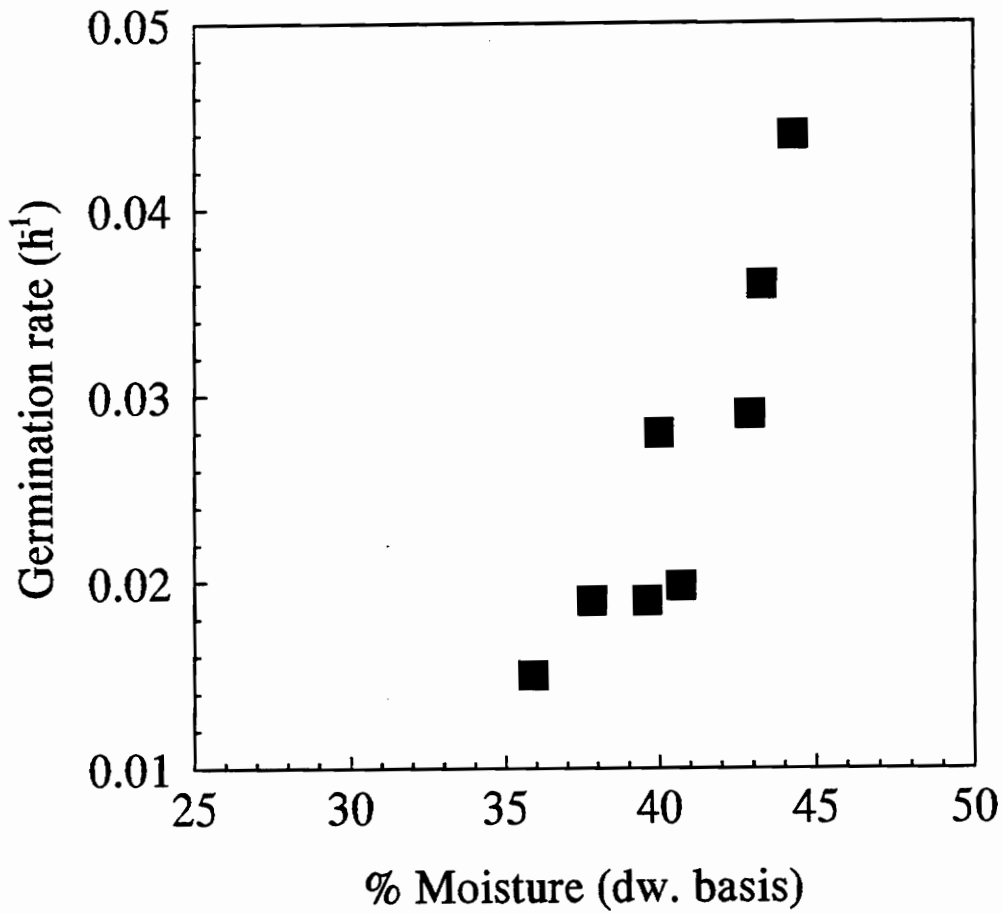

Figure 5.4. Relationship between germination rate and percent moisture content of seeds after priming in Ψ s of -1.0 to -2.5 MPa. Above 45% moisture content, germination occurs.

nonsymplastic (apoplastic) volume compared with nonprimed seeds (Table 5.1; Figure 5.5 A and B). This increase could be the result of the significant and irreversible increase in volume associated with priming. Primed seeds had a lower osmotic potential at full hydration relative to nonprimed seeds. However, there was no statistically significant difference in the ψ_{π} or ψ_p at full hydration between primed and nonprimed broccoli seeds. Liou (1987) measured the water relations characteristics of primed cabbage (*Brassica oleracea* L. var. *capitata*) seeds, and reported that primed seeds also did not have a significantly greater ψ_p . At full hydration, the ψ_{π} of primed and nonprimed cabbage seeds was ≈ -3.0 MPa. My data show that primed, intact, broccoli seeds had an $\psi_{\pi} = -1.95$ MPa and -1.54 MPa for primed and nonprimed seeds, respectively (Table 5.1). Bradford (1986) initially hypothesized that the ψ_{π} changed significantly during priming of tomato (*Lycopersicon esculentum* Mill.) seeds, but further experimentation by Dahal and Bradford (1990) and Haigh (1988) revealed that the embryo ψ_{π} changed little during priming.

Further experimental evidence supports the lack of difference in water relations between primed and nonprimed seeds. As initially reported, primed seeds do not exhibit a significantly greater water content at full hydration relative to nonprimed seeds. The free spaces that are conserved upon redrying primed seeds do not allow the seed to hold a greater quantity of water. It is likely that the free spaces are filled with the rapidly expanding embryo upon reimbibition of primed seeds. In previous research (cf. chapter 4) I observed no difference in the minimum Ψ allowing germination. If priming induces greater turgor, primed seeds should, in theory, germinate at a lower Ψ than nonprimed seeds.

The effects of seed priming on individual species are quite diverse. The length of phase II determines the time spread between initial water uptake and radical protrusion. The

Table 5.1 Change in water relations in response to priming.

Treatment	Ψ_{π}^z (MPa)	Nonsymplastic water content (%)	Symplastic water content (%)	Bulk turgor loss point (MPa)
Primed	-1.95	24	76	-2.1
Nonprimed	-1.54	17	83	-2.3
<i>Significance^y</i>	<i>NS</i>	*	*	<i>NS</i>

^zOsmotic potential at full hydration (100% RWC).

^y* Significant at $P \leq 0.05$; Mean of two experiments, four replications each.

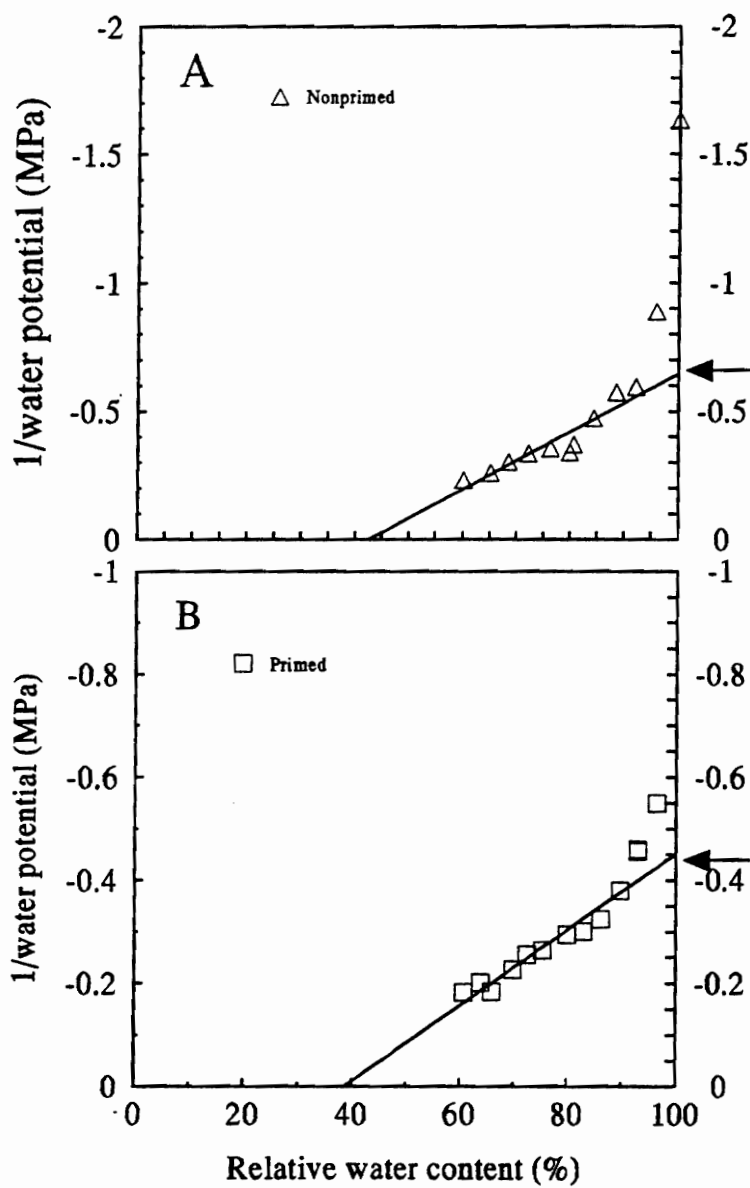

Figure 5.5. Representative Ψ isotherms of (A) nonprimed, and (B) primed seeds. Arrows mark the ψ_{π} at full hydration (100% RWC).

length of the plateau phase of broccoli seeds may be controlled by the length of time it takes for the restraining force of the testa to fall below the turgor of the expanding embryo.

Literature Cited

- Argerich, C. A. and K. J. Bradford. 1989. The effects of priming and ageing on seed vigour in tomato. *J. Exp. Bot.* 40:599-607.
- Bewley, J. D. and M. Black. 1994. *Seeds: Physiology of development and germination*. 2nd ed. Plenum Press, New York, NY.
- Bradford, K. J. 1986. Manipulation of seed water relations via osmotic priming to improve germination under stress conditions. *HortScience* 21:1105-1112.
- Bradford, K. J. 1990. Water relations of seed germination. *Plant Physiol.* 94:840-849.
- Copeland, L. O. and M. B. McDonald. 1985. *Principles of seed science and technology*. 2nd ed. Macmillan Publishing Co., New York, NY.
- Dahal, P. and K. J. Bradford. 1990. Effects of priming and endosperm integrity on seed germination rates of tomato genotypes. II. Germination at reduced water potential. *J. Exp. Bot.* 41:1441-1453.
- Gross, K. and W. Koch. 1991. Water relations of *Picea abies*. II. Determination of the apoplastic water content and other water relations parameters of needles by means of capillary microcryoscopy and the pressure-volume analysis. *Physiol. Plant.* 83:296-303.
- Gummerson, R. J. 1986. The effect of constant temperatures and osmotic potential on the germination of sugarbeet. *J. Exp. Bot.* 37:729-741.
- Haigh, A. M. Why do tomato seeds prime? Physiological investigations into the control of tomato seed germination and priming. *Ph.D. Dissertation*, Macquarie University, Sydney, Australia.
- Hegarty, T. W. 1977. Seed activation and germination under moisture stress. *New Phytol.* 78:349-359.
- ISTA 1985. International rules for seed testing. 1985. *Seed Sci. Technol.* 13:299-355.

- Khan, A. A. 1992. Preplant physiological seed conditioning. *Hort. Rev.* 14:131-181.
- Kramer, P. J. 1982. *Water relations of plants*. Academic Press, Inc., San Diego, CA.
- Leopold, A. C. and C. W. Vertucci. 1989. Moisture as a regulator of physiological reaction in seeds. In: *Seed Moisture*. (P. C. Stanwood and M. B. McDonald, eds.). CSSA Special Publication Number 14. Crop Science Society of America, Madison, Wisconsin.
- Liou, T. D. 1987. Studies on germination and vigour of cabbage seeds. *Ph.D. Dissertation*, Agricultural University, Wageningen, The Netherlands pp.101.
- Michel, B. E. 1983. Evaluation of water potentials of solutions of polyethylene glycol 8000 both in the absence and presence of other solutes. *Plant Physiol.* 72:66-70.
- Parera, C. A. and D. J. Cantliffe. 1992. Enhanced emergence and seedling vigor in shrunken-2 sweet corn via seed disinfection and solid matrix priming. *J. Amer. Soc. Hort. Sci.* 117:400-403.
- Scott, S. J., R. A. Jones, and W. W. Williams. 1984. Review of data analysis methods for seed germination. *Crop Sci.* 24:1172-1174.
- Tarquis, A. A. and K. J. Bradford. 1992. Prehydration and priming treatments that advance germination also increase the rate of deterioration of lettuce seeds. *J. Exp. Bot.* 43:307-317.
- Tyree, M. T. and P. J. Jarvis. 1982. Water in tissue and cells, p. 35-77. In: *Encyclopedia of plant physiology. New Series*, (O. L. Lang, P. S. Nobel, C. B. Osmond, and H. Ziegler eds.). Vol 2B. Springer-Verlag, Berlin.
- Welbaum, G. E. 1993. Water relations of seed development and germination in muskmelon (*Cucumis melo* L.). VIII. Development of osmotically distended seeds. *J. Exp. Bot.* 44:1245-1252.

Welbaum, G. E. and F. G. Meinzer. 1990. Compartmentation of solutes and water in developing sugarcane stalk tissue. *Plant Physiol.* 93:1147-1153.

Chapter 6

Effects of Priming on Developing Broccoli Seeds

Abstract. Seed development in broccoli (*Brassica oleracea* var. *italica* Plenck) was studied to gain a greater understanding of how seed vigor and viability change with development, how drying affects seed vigor and viability, and how priming affects vigor during seed development. Germination rate was used to measure vigor of seeds harvested from 14 days after pollination (DAP) until ≥ 56 DAP. Maximum seed dry weight was attained at 42 DAP, with maximum germination rate and viability observed at ≥ 49 DAP. The hulls (empty siliques) had a significantly higher relative growth rate from 14 to 28 DAP and reached maximum dry weight two weeks earlier than the seeds. Drying over silica gel improved germination performance at stages < 49 DAP. Dry storage of mature seeds did not improve vigor or viability indicating no after-ripening occurred. Priming significantly improved germination rate and viability of seeds at all stages of development, with the most significant effects observed before attainment of maximum dry weight.

Introduction

Studies of seed development in the family Brassicaceae have concentrated on seeds of the oil-bearing *Brassica* spp. such as *B. napus* and *B. juncea* (Canvin, 1963; Gupta, 1962; Fowler and Downy, 1970; Gurr et al., 1972; Norton and Harris, 1975). Little information is available detailing seed development of *Brassica oleracea*, a group of economically important vegetable crops. Mustard (*Sinapis alba* L.), a related species, has been studied for development of desiccation tolerance and precocious germination and is reported to reach maturity 60 days after pollination (DAP) (Fischer et al., 1988). Immature mustard

seeds, as young as 14 DAP however, germinate without dehydration, indicating that desiccation does not serve as an environmental signal for switching the seed from a developmental to a germination mode. Drying before the attainment of maximum dry weight decreased germination capacity. Seeds of *Phaseolus vulgaris* L. achieve maximum dry weight 50 to 55 DAP but germinate as early as 25 DAP when dried (Kermode et al., 1986).

Certain *Brassica* spp. seeds exhibit postharvest dormancy. Specifically, *Brassica oleracea* seeds have been observed to exhibit a wide spectrum of dormancy ranging from no dormancy to deep dormancy that may be prolonged or removed (depending on the species) by dry storage, which suggests an after-ripening requirement (Tokumasu, 1970). In addition, mustard seeds at the developmental stage ≤ 38 DAP exhibit a lag phase in germination, and are believed to require a further period of development during which the embryo continues to accumulate storage protein and lipids at the expense of the surrounding tissue (Fischer et al., 1988). Crambe (*Crambe abyssinica* Hochst. ex. R.E. Fries) possesses primary dormancy related to physical restrictions of the seed coat (Gutormson et al., 1993).

Brassica spp. crops have an extended flowering period as a result of both progressive development within a given raceme and variability among multiple racemes (Still and Bradford, 1994). Harvesting too early results in poor seed quality due to immaturity, and harvesting too late will reduce seed yields as a result of shattering. Therefore, at harvest, a given raceme can yield seeds at different stages of maturity and vigor.

Seed priming (imbibition in osmotic solution followed by redrying) consistently increases the vigor of broccoli (*Brassica oleracea* var. *italica* Plenck) seeds (cf. chapter 2). Priming is thought to increase seed vigor by advancing the physiological and morphological development of some seeds (van der Toorn, 1989; Wiebe and Tiessen,

1979). Thus, if broccoli seeds require a period of after-ripening, one of the beneficial effects of priming may be to substitute for an after-ripening requirement by allowing further physiological development (Welbaum and Bradford, 1992). The objectives of this research were to examine seed development of broccoli, coordinate vigor and viability changes with development, study the effects of drying on viability and vigor, and examine the effects of priming on seed vigor at each stage of development.

Materials and Methods

Plant material. Broccoli seeds (the open pollinated cv. 'Waltham-29') were seeded in no.128 plug trays on 16 September 1993 in a greenhouse. Five weeks after seeding, twenty plants each were transplanted into 0.5 l pots filled with Pro-mix BX media (Fisons Horticulture Inc., Mississauga, Ontario, Canada). Sixteen plants were randomly grouped into four replications of four plants each. Supplemental lighting (1000 watt, 60HZ, Sylvania Corp.) provided a 14-h photoperiod, and the temperature of the greenhouse was maintained at $\approx 25^{\circ}\text{C} \pm 5^{\circ}\text{C}$ and 30% relative humidity (RH). Plants were hand-watered once per day, and 20N-2.2P-25K liquid fertilizer (W.R. Grace and Co., Fogelsville, PA) was applied once every two weeks to enhance vegetative growth, and once per week after flowering commenced through harvest. Flowering was first observed on 28 December 1993, and flowers were bud-pollinated before flowering by carefully removing petals 1 to 3 d before flowering, and, using forceps to hold the filament, brushing the stamen from an adjacent plant on the stigmatic surface ≈ 16 to 20 times. Pollinated flowers were tagged to indicate the date of pollination, and approximately 200 flowers per plant were pollinated.

Germination testing. Immature seeds and siliques were harvested at 7-d intervals beginning 14 DAP. Using forceps sterilized with a 0.1 v/v NaOCl solution, the seeds were

aseptically removed from siliques within 15 min after harvest in a humidified box (100% RH) using a dissecting microscope ($\times 25$). For determination of dry weight and fresh weight changes, 25 seeds were removed from the siliques at each stage of development, weighed fresh, and dried for 17 h at 102°C (ISTA, 1985). For germination testing, 20 seeds were removed from siliques at each stage of development (fresh) and immediately transferred to a germination petri dish or dried over silica gel in a desiccator maintained at 30% RH and room temperature ($22 \pm 3^\circ\text{C}$) for 7 d. After 7 d, the moisture content of the seeds (≥ 42 DAP) equilibrated to $\leq 10\%$ (dw. basis), while seeds < 42 DAP attained the same moisture content in only 3 d. The fresh or dried seeds at each stage of development were germinated in 8.5 cm-petri dishes on two thicknesses of germination blotter paper (Ahlstrom Filtration, Mount Holly Springs, PA) saturated with 12 ml of distilled water and misted with a 0.02% thiram (tetramethylthiuram disulfide) solution to protect the seeds against pathogens. All germination testing was performed at 25°C in a dark incubator. Seeds were scored for germination (visual radical emergence) at approximately 6-h intervals. To test the effects of dry storage, some broccoli seeds were stored for 30 d in a desiccator (30% RH) at 25°C prior to testing.

Priming conditions. Both fresh and dry seeds were primed in -1.2 MPa polyethylene glycol (PEG 8000; 12 ml·g⁻¹ seed) verified with a vapor pressure osmometer (model 5100C, Wescor Inc., Logan, UT) calibrated with NaCl solutions of known water potentials (Ψ). Seeds were primed for 7 d at 20°C in a dark incubator, then removed from the PEG solutions, vigorously rinsed in tap water for 2 min, and forced-air dried (35°C) for 5 min. After initial drying, seeds were stored in a silica gel desiccator (30% RH) for 7 d prior to germination testing. After removing the seeds from the siliques, three replications of four hulls each were weighed and dried at 70°C for 72 h to determine fresh

weight and dry weight. Relative growth rates (RGR) of the seeds and hulls were calculated according to Radford (1967).

Statistical analysis. Cumulative germination percentages were plotted on a probit scale versus log time (t). Straight lines of approximately equal slope were produced for different Ψ s, indicating a normal distribution of germination events with log time (data not shown). The log mean time to 50% germination (log t) was determined graphically as the intersection of the least squares regression line of the log (base 10) time versus probit germination percentage and 50% germination. The germination rate was calculated as inverse log t. Germination percentages were arcsin transformed to normalize the variances of binomial data before ANOVA (CoStat, CoHort Software, Berkeley, CA).

Results and Discussion

Dry and fresh weight changes with development. Seed fresh weight (mg/seed) increased linearly from 14 to 28 DAP due to the formation of the liquid endosperm which occupied \approx 50% of the seed volume as early as 14 DAP (Figure 6.1 A). The liquid endosperm occupies the entire interior of the seed by 21 DAP and was subsequently resorbed by the developing cotyledons and replaced by the expanding embryo (Fischer et al., 1988). Between 28 and 49 DAP, broccoli seed fresh weight remained constant. Seed dry weight plateaued at 42 DAP indicating the attainment of physiological maturity. The funiculus degenerated 49 DAP, causing the seed to abscise. After abscission, the fresh weight declined until 56 DAP when the fresh weight and dry weight were essentially equal.

Coinciding with the attainment of physiological maturity at 42 DAP, seed coats changed color from green to brown. Changes in seed coat color at the time of maximum dry weight or physiological maturity is commonly observed with many seed species. For example, reddening of wheat (*Triticum aestivum* L. em Thell.) seeds marks the

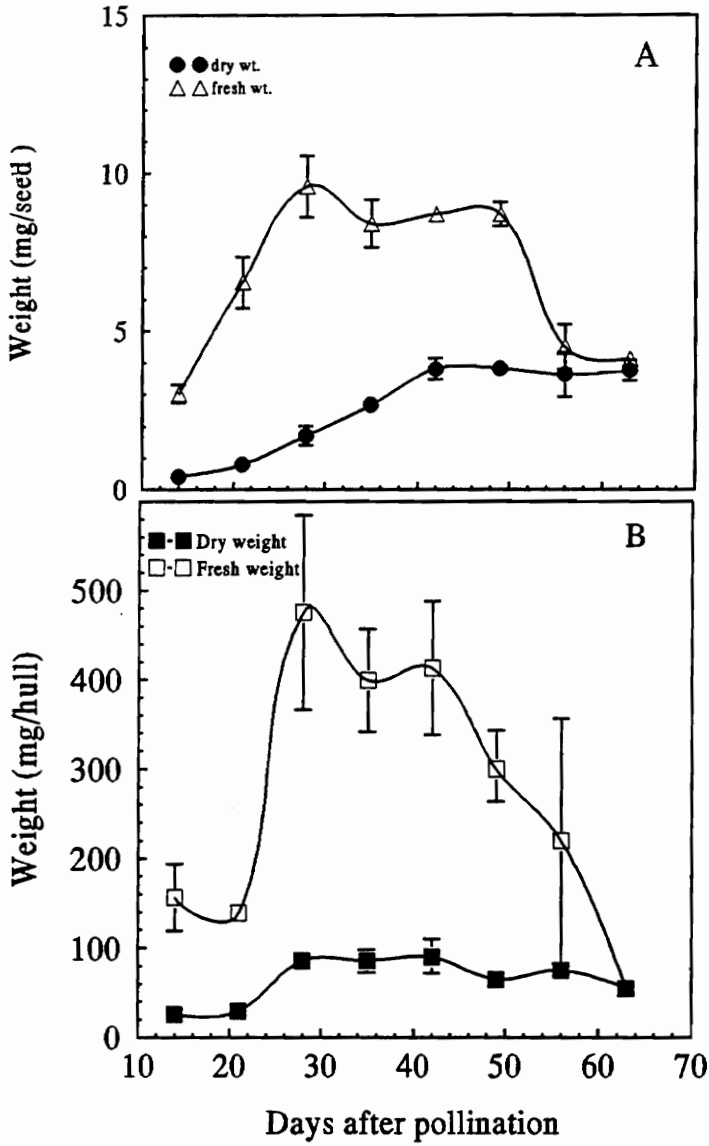

Figure 6.1. Dry and fresh weight changes of broccoli seeds (A) and hulls (empty siliques) (B). Vertical bars represent \pm standard errors of the means of six replications.

termination of dry matter accumulation (Housely et al., 1982). Also, Fischer et al. (1988) reported a complete loss of chlorophyll content in mustard seed coats by 42 DAP.

Hull fresh weight, like the enclosed seeds, increased from 21 to 42 DAP and subsequently declined (Figure 6.1 B). Dry weight of the hulls followed a similar sigmoidal pattern as the seeds and increased significantly from 21 to 35 DAP. Maximum dry weight of the hulls occurred at 28 DAP, two weeks earlier than attainment of seed maximum dry weight. The faster rate of growth of hulls is represented by a higher RGR from 14 to 28 DAP compared to the developing seeds (Figure 6.2). Beyond 49 DAP developmental stage, there was a rapid decline in fresh weight of the hulls. At 56 DAP, the hulls had a dry, brown texture, and began to shatter \approx 84 DAP.

Changes in viability and vigor. At 14 and 21 DAP, all fresh seeds failed to germinate and were eventually destroyed by pathogens. Precocious germination (germination before maximum dry weight is attained) was first observed 28 DAP with \approx 5% of the fresh seeds germinating. Thus, the broccoli seeds were competent to germinate even as development was proceeding before the accumulation of maximum dry weight. Viability (germination percentage) of developing seeds continued to increase with maximum viability observed at between 49 and 56 DAP.

Still and Bradford (1994) reported that maximum vigor (germination rate) of red cabbage (*Brassica oleracea* var. *capitata*) seeds was attained at 48 DAP. Maximum vigor of broccoli seeds was reached at \geq 49 DAP, coinciding with attainment of maximum dry weight (Table 6.1; Figure 6.3 A).

Effects of drying on viability and vigor. Drying 21 and 28 DAP seeds to \leq 10% moisture content resulted in no germination, indicating desiccation intolerance or the failure of the young seeds to survive the drying regime used. The beneficial effects of drying treatment on germination depends on the age of the seeds at harvest time and the rate of drying

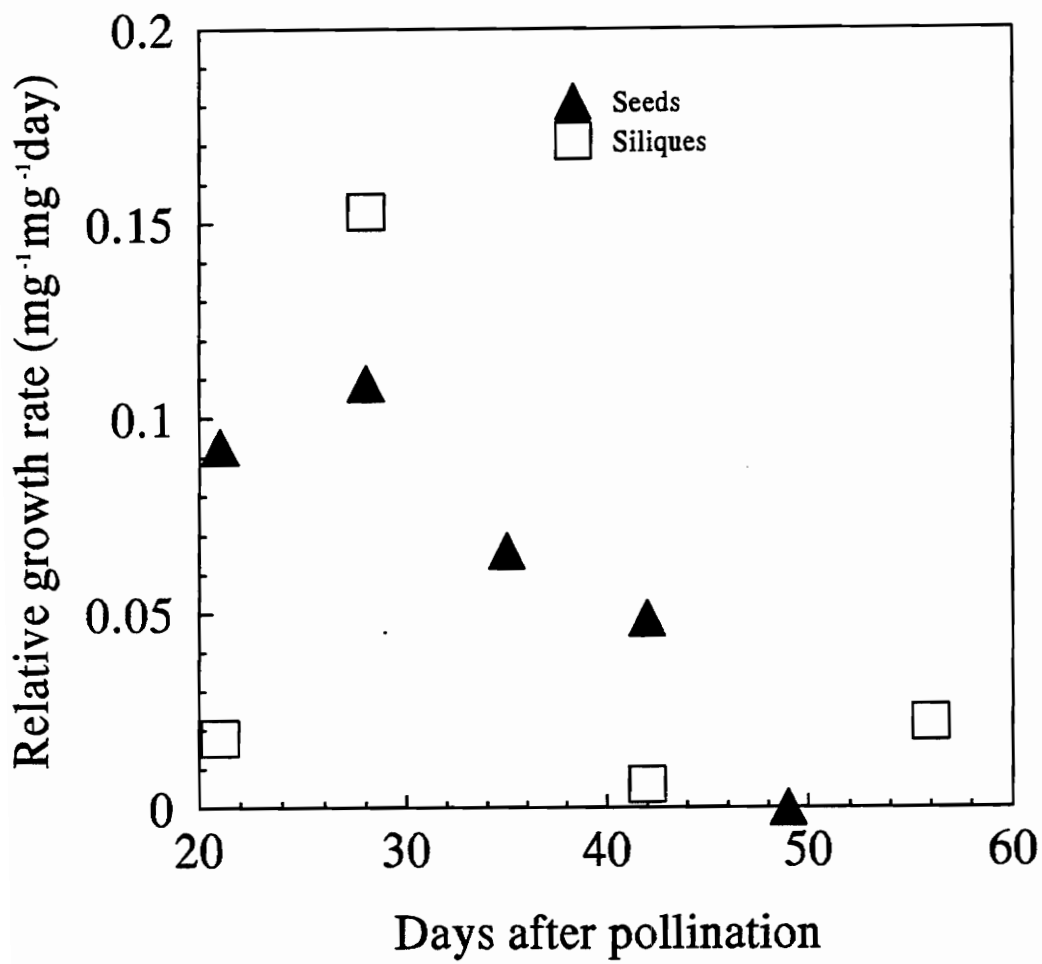

Figure 6.2. Relative growth rate of siliques and seeds.

Table 6.1. Effects of developmental age, drying and priming on vigor and viability of broccoli seed.

Days after pollination	Fresh or Dried	Primed	Mean time to germination (h)	Germination ^Z (%)
28	F	-	-	5
35	D	-	149.8	48
	D	+	68.3	43
	F	-	207.3	38
	F	+	-	3
42	F	-	116.0	73
	F	+	52.1	87
	D	-	72.0	85
	D	+	29.0	95
49	F	-	28.7	85
	F	+	31.3	77
	D	-	29.3	63
	D	+	86.1	78
56	F	-	39.7	92
	F	+	27.7	75
	D	-	46.3	68
	D	+	24.4	80
>56 ^Y			43.6	52
<i>F</i> significance				
Developmental age			***	***
Priming			***	***
Drying			NS	***
Developmental age x Priming			***	**
Drying x Priming			*	***
Drying x Developmental age			NS	**
Developmental age x Priming x Drying			NS	NS

^ZPercentage data arcsin transformed prior to analysis. D= dried; F= Fresh; + and - denotes yes and no, respectively.

^YStorage for 30 days.

*, **, *** Significant at P < 0.05, 0.01, or 0.001, respectively.

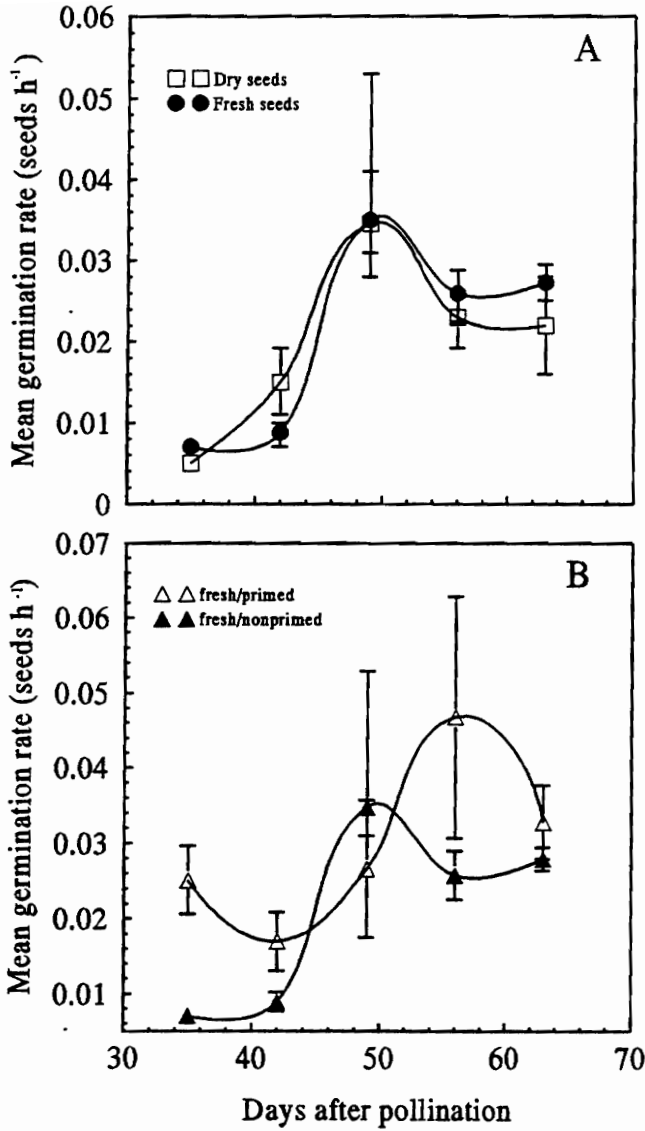

Figure 6.3. Effects of drying (A) and priming (B) on the germination rate of developing broccoli seeds.

termination of dry matter accumulation (Houseley et al., 1982). Also, Fischer et al. (1988) reported a complete loss of chlorophyll content in mustard seed coats by 42 DAP.

Hull fresh weight, like the enclosed seeds, increased from 21 to 42 DAP and subsequently declined (Figure 6.1 B). Dry weight of the hulls followed a similar sigmoidal pattern as the seeds and increased significantly from 21 to 35 DAP. Maximum dry weight of the hulls occurred at 28 DAP, two weeks earlier than attainment of seed maximum dry weight. The faster rate of growth of hulls is represented by a higher RGR from 14 to 28 DAP compared to the developing seeds (Figure 6.2). Beyond 49 DAP developmental stage, there was a rapid decline in fresh weight of the hulls. At 56 DAP, the hulls had a dry, brown texture, and began to shatter \approx 84 DAP.

Changes in viability and vigor. At 14 and 21 DAP, all fresh seeds failed to germinate and were eventually destroyed by pathogens. Precocious germination (germination before maximum dry weight is attained) was first observed 28 DAP with \approx 5% of the fresh seeds germinating. Thus, the broccoli seeds were competent to germinate even as development was proceeding before the accumulation of maximum dry weight. Viability (germination percentage) of developing seeds continued to increase with maximum viability observed at between 49 and 56 DAP.

Still and Bradford (1994) reported that maximum vigor (germination rate) of red cabbage (*Brassica oleracea* var. *capitata*) seeds was attained at 48 DAP. Maximum vigor of broccoli seeds was reached at \geq 49 DAP, coinciding with attainment of maximum dry weight (Table 6.1; Figure 6.3 A).

Effects of drying on viability and vigor. Drying 21 and 28 DAP seeds to \leq 10% moisture content resulted in no germination, indicating desiccation intolerance or the failure of the young seeds to survive the drying regime used. The beneficial effects of drying treatment on germination depends on the age of the seeds at harvest time and the rate of drying

(Kermode et al., 1989). Seeds of legumes (Ellis et al., 1987) and maize (*Zea mays* L.) (Kermode et al., 1989) for example, are unable to withstand rapidly imposed drying (over silica gel) at early stages of development. Although not entirely understood, it is believed that rapid drying damages cellular membranes (Crowe et al., 1989). At 35 DAP, broccoli seeds showed the first signs of surviving desiccation. At 42 DAP, all seeds were desiccation tolerant (Table 6.1). Drying did not effectively improve viability at any developmental stage. Since broccoli seeds are capable of germinating at 21 and 28 DAP immediately after removal from the silique, drying is not an inductive signal for switching from development to germination.

When full desiccation tolerance was reached at 42 DAP, drying improved the germination rate relative to fresh, nondried seeds of the same developmental age (Table 6.1). However, drying 49 DAP seeds that had reached maximal dry weight did not significantly improve vigor. Drying of the physiologically immature seeds that are desiccation tolerant over silica gel for 7 d possibly allowed further seed development to occur. However, since the vigor level of dried 42 DAP seeds was significantly less than fresh 49 DAP seeds, it is unlikely that full development occurred during dry storage. Tokumasu (1970) reported that dormancy of *Brassica napus* was removed by dry storage in a desiccator for 30 d, but *Brassica pekinensis* and *Brassica rapa* showed no signs of dormancy. In my study, dry storage of seeds > 56 DAP did not significantly improve seed vigor or viability (Table 6.1). The lack of any improvement with storage suggests no need for after-ripening of fully mature (> 56 DAP) broccoli seeds.

Effects of priming. Priming, by definition, entails redrying the seed to its initial moisture content after a period of controlled hydration. Thus, priming (either of fresh or dried seeds) is likely to manifest a beneficial effect to developing seeds perhaps as a result of drying alone or by prolonged hydration which allows development to continue in

immature seeds. In general, priming significantly improved vigor and viability at all stages of development, with the exception of 35 DAP dried seeds, which were not fully desiccation tolerant (Table 6.1; Figure 6.3 B). Priming did more than allow immature seeds to develop. For example, priming 35 DAP fresh seeds improved the germination rate significantly more than 42 DAP fresh seeds.

At 35 DAP, primed, fresh seeds had a significantly greater vigor than both fresh or dried, nonprimed seeds. The most significant effects of priming on vigor were observed with younger (i.e. 35 DAP to 49 DAP; primarily fresh) seeds (Figure 6.3 B) resulting in a significant interaction between developmental age and priming (Table 6.1). Since priming has been observed to result in advancement of seed development of some vegetable species, it is plausible that priming seeds before physiological maturity has positive effects related to developmental or morphological advancement. However, once physiological maturity was reached at ≥ 42 DAP, priming (both fresh and dried) continued to significantly improve the MGR.

One of the effects hypothesized to explain increased vigor of primed seeds is cellular repair. Priming of broccoli seeds does not act solely as a repair mechanism since undamaged, immature seeds exhibited increased vigor after priming. Furthermore, attainment of maximum vigor at 49 DAP and the lack of enhancement of seeds in dry storage indicate that broccoli seeds do not require a period of after-ripening after maximum dry weight is attained. All of these facts suggest the enhancement in broccoli seed vigor routinely associated with priming is related to a morphological or physiological development requirement before physiological maturity (42 DAP) but not substituting for final ripening stages of mature (> 56 DAP) broccoli seeds.

Literature Cited

- Canvin, D. T. 1963. Formation of oil in the seed of *Ricinus communis* L. *Can. J. Biochem. Physiol.* 41:1879-1885.
- Crowe, J. H., L. M. Crowe, F. S. Hoekstra, and C. A. Wistrom. 1989. Effects of water on the stability of phospholipid bilayers: the problem of imbibition damage in dry organisms. In: *Seed Moisture*. (P. C. Stanwood and M. B. McDonald (eds.)) Crop Science Society of America, Madison, WI.
- Dasgupta, J., J. D. Bewley and E. C. Yeung. 1982. Desiccation-tolerant and desiccation-intolerant stages during the development and germination of *Phaseolus vulgaris* seeds. *J. Exp. Bot.* 33:1045-1057.
- Ellis, R. H., T. D. Hong, and E. H. Roberts. 1987. The development of desiccation-tolerance and maximum seed quality during seed maturation in six grain legumes. *Ann. Bot.* 59:23-29.
- Finkelstein, R. R. and M. L. Crouch. 1984. Precociously germinating rapeseed embryos retain characteristics of embryogeny. *Planta* 162:125-131.
- Fischer, W., R. Bergfield, C. Plachy, R. Schäfer, and P. Schopfer. 1988. Accumulation of storage materials, precocious germination and development of desiccation tolerance during seed maturation in mustard (*Sinapis alba* L.). *Bot. Acta* 101:344-354.
- Fowler, D. B. and R. K. Downey. 1970. Lipid and morphological changes in developing rape seed, *Brassica napus*. *Can. J. Plant Sci.* 50:233-247.
- Gupta, G. P. 1962. Synthesis of oil at various stages of seed development in linseed. *Indian Oilseeds J.* 4:205-210.

- Gurr, M. I., J. Blades, R. S. Appleby. 1972. Studies on seed-oil triglycerides. The composition of *Crambe abyssinica* triglycerides during seed maturation. *Europ. J. Biochem.* 29:362-368.
- Gutormson, T. J., K. L. Larson, and T Waqar. 1993. Germination of freshly-harvested and after-ripened crambe (*Crambe abyssinica* Hochst. Ex. R.E. Fries) seed. *J. Seed Technol.* 16:17-23.
- Housley, T. L., A. W. Kirleis, H. Ohm, and F. L. Patterson. 1982. Dry matter accumulation in soft red winter wheat seeds. *Crop Sci.* 22:290-294.
- Kermode, A. R., M. Y. Oishi, and J. D. Bewley. 1989. Regulatory roles for desiccation and abscisic acid in seed development: a comparison of the evidence from whole seeds and isolated embryos. In: *Seed Moisture*. (P. C. Stanwood and M. B. McDonald eds.). p. 23-50, Crop Science Society of America, Madison, WI.
- Michel, B. E. 1983. Evaluation of the water potentials of solutions of polyethylene glycol 8000 both in the absence and presence of other solutes. *Plant Physiol.* 72:66- 70.
- Norton, G. and J. F. Harris. 1975. Compositional changes in developing rape seed (*Brassica napus* L.). *Planta* 123:163-174.
- Radford P. J. 1967. Growth analysis formulae - their use and abuse. *Crop Sci.* 7:171-175.
- Still, D. W. and K. J. Bradford. 1994. Development of seed quality in red cabbage. *HortScience* 29:552 (Abstr.).
- Tokumasu, S. 1970. Effect of dry and wet storage upon seed dormancy in cruciferous vegetables. *J. Jpn. Soc. Hort. Sci.* 40:23-27.
- van der Toorn, P. 1989. Embryo growth in mature celery seeds. *Ph.D. Dissertation*, Agricultural University, Wageningen, The Netherlands.

- Welbaum G. E. and K. J. Bradford. 1991. Water relations of seed development and germination of muskmelon (*Cucumis melo* L.). VI. Influence of priming on germination responses to temperature and water potential during seed development. *J. Exp. Bot.* 42:393-399.
- Wiebe, H. J. and T. H. Tiessen 1979. Effects of different seed treatments on embryo growth and emergence of carrot seeds. *Gartenbauwissenschaft* 44:280-284.

Chapter 7

Effects of Seed Size and Position Within the Silique on Germination and Vigor of Broccoli

Abstract. This study examined the vigor and germination of broccoli seeds at apical and basal positions within the silique, seed and seedling vigor of large and small seeds, and the effects of priming (imbibition followed by redrying) on large and small broccoli seeds. Seeds were harvested from plants grown in a greenhouse and separated by position in the silique at 42 (physiological maturity) and 56 days after pollination (DAP) (harvestable maturity). To evaluate the effects of seed size, large and small seeds were visually sorted after harvest. Vigor was assessed by the mean time to germination (MTG). There was no significant difference in MTG, germination percentage, or fresh weight between apical and basal seeds. Seeds collected at harvestable maturity (≥ 56 DAP) germinated faster and to higher percentages than seeds harvested at physiological maturity (42 DAP). Large seeds did not germinate faster than small seeds. Priming significantly reduced the MTG of all seeds regardless of their size but did not significantly increase the vigor of small relative to large seeds. Large seeds produced seedlings with a significantly greater dry weight per seedling.

Introduction

Much of the research on seed development in *Brassica* spp. has concentrated on measurement of dry matter and oil accumulation within the oil-bearing seeds *Brassica* spp. (e.g. *B. napus*) (Canvin, 1963; Fowler and Downey, 1970; Gurr et al., 1972; Norton and Harris, 1975). Very little research has been conducted on the development of germinability and vigor of *B. oleracea* seeds, an important species of food crops.

Little is known about how position of the developing seed within the silique affects germination and vigor. Egli et al., (1978) reported that position of soybean (*Glycine max* L.) seeds within the pod significantly affected seed size but did not affect the seed filling period. Whether this difference in seed size translated into differences in vigor is not known.

Seed size is often used to classify the quality of seeds (Liou, 1987). The effects of seed size on emergence, growth, and yield of many vegetable species is well documented. Tomato (*Lycopersicon esculentum* var. *esculentum*), pimento (*Capsicum annuum* L.), and broccoli (*Brassica oleracea* var. *italica* Plenck) seeds have shown a positive correlation of seed size with seedling growth (Cochrane, 1974; Jacobsohn and Globerson, 1980; Tomkins, 1966). Moreover, seedling stand, dry weight, and final yield of broccoli in crusted soils has been increased as seed size increased (Heather and Sieczka, 1991). Liou (1987) and Mian et al. (1994), however, reported that seed size had no effect on germination percentage and vigor (rate of germination) of cabbage (*Brassica oleracea* var. *capitata*) and wheat (*Triticum aestivum* L.) seeds, respectively, but did result in larger seedlings. The advantage of heavy seeds presumably lies in their higher cotyledonary reserves and in their ability to provide energy more rapidly to the growing seedlings (Smith et al., 1973).

If there is a significant difference in seed vigor between large and small broccoli seeds, seed enhancement techniques such as priming (imbibition followed by redrying) may be more beneficial to a seed lot of relatively smaller seeds compared to a seedlot with larger seeds. In this study, we investigated seed development within the silique, germination and seedling growth of large versus small seeds, and the effects of priming small and large seeds on germination percentage and vigor.

Materials and Methods

Plant material. Broccoli seeds from the open-pollinated cultivar 'Waltham-29' were seeded in no. 128 plug trays on 16 September 1993 in a greenhouse. Five weeks after seeding, 16 plants were transplanted into 0.5-liter pots filled with Pro-mix BX media (Fisons Horticulture Inc., Mississauga, Ontario, Canada). Sixteen plants were randomly grouped into 4 replications containing 4 plants each. Supplemental lighting (1000 watt, 60HZ, Sylvania Corp.) was used to deliver a 14-h photoperiod, and the temperature of the greenhouse was maintained at $\approx 25 \pm 5^\circ\text{C}$ and 30% relative humidity (RH) throughout the experiment. Plants were hand-watered once per day, and 20N-2.2P-25K liquid fertilizer (W. R. Grace and Co., Fogelsville, PA) was applied once every two weeks to enhance vegetative growth, and once per week after flowering commenced through harvest. Flowering was first observed on 28 December 1993, and flowers were bud-pollinated by carefully opening the flower petals from flowers that were expected to open within 1 to 3 d, and brushing the stamen from an adjacent plant on the stigmatic surface ≈ 16 to 20 times with forceps. Pollinated flowers were tagged to indicate the date of pollination, and approximately 200 flowers per plant were pollinated.

Based on a previous study (cf. chapter 6), it was determined that maximum dry weight of broccoli seeds occurred at 42 days after pollination (DAP), (physiological maturity), and maximum germination and vigor was observed at 56 DAP (harvestable maturity). Therefore, to determine the effect of position of the seed within the silique on germination and vigor, siliques were harvested at 42 and 56 DAP and taken to the laboratory. One to two seeds from the apical and basal ends of the silique (average of 10 seeds/silique) were removed in a humidified box under a dissecting microscope ($\times 25$). The siliques had an average of 10 seeds. After removal, three replications of 20 seeds were weighed and transferred to petri dishes for germination testing.

To determine the effects of seed size on germination and vigor, seeds were harvested from siliques that reached harvestable maturity (dry, brown siliques), then taken immediately to the laboratory and separated from the hulls. The seeds were separated from the siliques in a laboratory and placed in a silica gel desiccator at 30% RH and 20°C for 7 d to reduce the seed moisture content to $\leq 10\%$. After 7 d, the seeds were removed from the desiccator and subjectively sorted into large and small fractions and stored in sealed plastic bottles at 4°C until needed..

Priming conditions. Seeds were primed in -1.2 MPa polyethylene glycol (PEG 8000; 12 ml·g⁻¹ seed) verified with a vapor pressure osmometer (model 5100C, Wescor Inc., Logan UT) calibrated with NaCl solutions of known Ψ s. Seeds were primed for 7 d at 20°C in a dark incubator, then removed from the PEG solutions, vigorously rinsed in tap water for 2 min, and forced-air dried (35°C) for 5 min. After initial drying, seeds were stored in a silica gel desiccator (30% RH) for 7 d prior to germination testing.

Germination and seedling growth. Three replications of twenty seeds (both large and small) were dusted with tetramethylthiuram disulfide (thiram), and transferred to 8.5 cm² petri dishes containing two layers of germination blotter paper (Ahlstrom Filtration Inc., Mount Holly Springs, PA) moistened with 12 ml distilled water for germination testing. All germination tests were performed at 25°C in a dark incubator. Seeds were scored for germination (visual radical protrusion) at 6-h intervals. Mean time to germination (MTG or T₅₀) was calculated graphically by converting cumulative germination percent to probits and plotting the probit values versus log (base 10) time. The point of 50% germination (probit=5) on the least square regression line is the log T₅₀. Analysis of variance was performed on the antilog T₅₀.

For determination of seedling growth, large and small nonprimed seeds were germinated as above at 32°C. Three replications of eight germinated seeds were

transferred to 12x15 cm germination blotters that were thoroughly saturated with distilled water. The blotters with the seeds were placed on plexiglass slant boards oriented at a 45° angle, covered with plastic bags, and placed in a darkened growth chamber at 32°C. After 48 h, the seedlings were evaluated for abnormalities using ISTA (1986) standards, and the root length was measured with calipers (digimatic; Mitutoyo Corp., Tokyo, Japan). Dry weight per seedling was determined by weighing the seedlings after measurement and drying at 70°C for 72 h.

Results and Discussion

Position of the seed within the silique did not significantly affect either the MTG or the final germination percent at either 42 or 56 DAP (Table 7.1). Developmental age affected final germination percentage and germination rate. At harvestable maturity, the MTG was \approx 66% less than that observed with seeds at physiological maturity. Moreover, the final germination percentage increased 50% between the two developmental stages. The lack of difference in seed weight with position may indicate that the supply of photosynthates to the seed was not limiting. Research conducted with corn (*Zea mays* L.) and soybean suggests that the seed growth rate is largely controlled by mechanisms in the seed and not simply by the supply of photosynthates to the seed (Carter and Poneleit, 1973; Egli et al., 1978).

The average weight of the large and small seeds (dried to 5 to 6% moisture content), determined by weighing batches of 100 seeds each was 4.8 and 2.8 mg·seed⁻¹, respectively. Large broccoli seeds did not germinate faster than small seeds (Table 7.2). At *Brassica* spp. seed maturity, the cotyledons and hypocotyl of the embryo constitute the largest portion of the seed (Thompson, 1933). Therefore, large seeds have significantly larger embryos. Germination, however, is defined as culminating in radicle emergence

Table 7.1. Effect of seed position within the silique on germination of broccoli seed.

Days after pollination	Position	T₅₀^z (h)	Germination %	Fresh wt.·seed⁻¹ (mg)
42	Apical	124	42	6.2
	Basal	162	45	6.5
≥56	Apical	54.7	82	3.3
	Basal	37.9	87	3.3
<i>F Significance^y</i>				
Developmental age		**	***	***
Position		NS	NS	NS
Developmental age x Position		NS	NS	NS

^zT₅₀ is the mean time to germination (MTG).

^y*, **, *** significant at P = 0.05, 0.01, 0.001, respectively.

Table 7.2. Effects of seed size and priming on germination of broccoli seed.

Seed size ^z	Primed ^y	T ₅₀ ^x	Germination
		(h)	%
Small	+	13.1	95
Large	+	14.4	97
Small	-	19.3	92
Large	-	16.1	87
<i>F Significance</i> ^w			
Size		NS	NS
Primed		**	NS
Size x Primed		NS	NS

^z Large seeds weighed 0.48 g/100 seeds and small seeds weighed 0.28 g/100 seeds.

^y + and - represent primed and nonprimed, respectively.

^xT₅₀ is the mean time to germination.

^w *, **, *** significant at P = 0.05, 0.01, and 0.001, respectively.

without an increase in cell numbers (Bewley and Black, 1985). Thus the ability of a seed to germinate rapidly is not likely to be well correlated with seed size.

Priming significantly reduced the MTG of all seeds regardless of size by 22%, but it did not affect final germination percentage (Table 7.2).

Seed vigor and seedling vigor are often erroneously linked. For example, priming improves seed vigor, but does not increase the seedling growth rate (Jett and Welbaum, unpublished results; Argerich and Bradford, 1989). The metabolic processes that control germination rate are quite distinct from those that control seedling growth rate (Argerich and Bradford, 1989). Liou (1987) discovered that cabbage seed size did not affect seed vigor but did correlate well with seedling vigor as measured by larger seedlings.

The growth rate of the radicle as measured by root length 48 h after germination at 32° C indicated no significant difference between large and small seeds (Table 7.3). Also, the number of normal seedlings did not differ with either of the two seed sizes. The major advantage of large seeds was to produce significantly larger seedlings. Thus, even though large seeds lack a significant difference in root growth rate compared with small seeds, a larger cotyledonary area allowed the seedlings from large seeds to have greater seedling vigor that can potentially translate into earlier and greater yields of broccoli.

Table 7.3. Seedling evaluation of large and small seeds at 32°C.

Seed size	Dry wt.·seedling ⁻¹ (mg)	Root length (mm)	% Normal (seedlings)
Large	3.8	18.4	84.8
Small	2.5	21.2	92.6
<i>Significance</i> ^z	*	NS	NS

^z *, **, *** significant at P = 0.05, 0.01, and 0.001, respectively.

Literature Cited

- Argerich, C. A. and K. J. Bradford. 1989. The effects of priming and ageing on seed vigour in tomato. *J. Exp. Bot.* 40:599-607.
- Bewley, J. D. and M. Black. 1985. *Seeds: physiology of development and germination*. Plenum Press, New York.
- Canvin, D. T. 1963. Formation of oil in the seed of *Ricinus communis* L. *Canad. J. Biochem. Physiol.* 41:1879-1885.
- Carter, M. W. and C. G. Poneleit. 1973. Black layer maturity and filling period variation among inbred lines of corn (*Zea mays* L.). *Crop Sci.* 13:436-439.
- Cochran, H. L. 1974. Effect of seed size on uniformity of pimento transplants (*Capiscum annum* L.) at harvest time. *J. Amer. Soc. Hort. Sci.* 99:234-235.
- Egli, D. B. and J. M. Wood. 1978b. Influence of soybean seed size and position on the rate and duration of filling. *Agron. J.* 70:127-130.
- Fowler, D. B. and R. K. Downey. 1970. Lipid and morphological changes in developing rape seed, *Brassica napus*. *Canad. J. Plant Sci.* 50:233-247.
- Gurr, M. I., J. Blades, and R. S. Appleby. Studies on seed oil triglycerides. The composition of *Crambe abyssinca* triglycerides during seed maturation. *Europ. J. Biochem.* 29:362-368.
- Heather, D. W. and J. B. Sieczka. 1991. Effect of seed size and cultivar on emergence and stand establishment of broccoli in crusted soils. *J. Amer. Soc. Hort. Sci.* 116:946-49.
- Jacobsohn, R. and D. Globerson. 1980. *Daucus carota* (carrot) seed quality: I. Effects of seed size on germination, emergence and plant growth under subtropical conditions and II. The importance of the primary umbel in carrot seed production. In: *Seed Production* (P. D. Hebblethwaite ed.), p:637-646. Butterworths, London.

- Liou, T. D. 1987. Studies on germination and vigour of cabbage seeds. *Ph.D Dissertation*, Wageningen, The Netherlands. pp. 101.
- Mian, M. A. R. and E. D. Nafziger. 1994. Seed size and water potential effects on germination and seedling growth of winter wheat. *Crop Sci.* 34:169-171.
- Norton, G. and J. F. Harris. 1975. Compositional changes in developing rape seed (*Brassica napus* L.). *Planta* 123:163-174.
- Smith, O. E., N. C. Welch, and T. M. Little. 1973. Studies on lettuce seed quality. I. Effect of seed size and weight on vigor. *J. Amer. Soc. Hort. Sci.* 98:529-551.
- Thompson, R. C. 1933. A morphological study of flower and seed development in cabbage. *J. Agric. Res.* 47:215-232.
- Tompkins, D. R. 1965. Broccoli maturity and production as influenced by seed size. *J. Amer. Soc. Hort. Sci.* 88:400-405.

Chapter 8

The Effects of Priming on Storage and Repair of Broccoli Seeds

Abstract. Priming (controlled hydration followed by a dehydration treatment) invigorates broccoli seeds, and thus improves seed quality. The retention of vigor during storage is an important characteristic of seed quality. The objective of this research was to investigate the protective effects of priming by priming broccoli seeds prior to storage and aging, and the repair effects of priming on stored and poor quality seeds. Seeds (primed and nonprimed) were stored at 4°C for 4 years and germinated at 35°C. After storage, the nonprimed seeds were primed. Accelerated aging was used to reduce the vigor level of primed and nonprimed seeds. A seed lot with a high percentage of split seeds was primed, and seedlings were evaluated for growth and abnormalities. Priming caused seeds to retain vigor throughout storage, but nonprimed seeds exhibited a significant reduction in vigor as indexed by a greater mean time to germination (MTG). Priming protected both vigor and viability after aging. Priming invigorated damaged seeds, but did not reverse the effects of damage.

Introduction

Priming (controlled hydration followed by redrying) of broccoli (*Brassica oleracea* var. *italica* Plenck) seeds has consistently increased seed vigor as indexed by a faster rate of germination and emergence (cf. chapter 3). The ability of primed seeds to retain vigor after storage is of paramount interest to both growers and handlers of seeds. Loss of seed

vigor is associated with several symptoms which include reduced rate of germination and emergence, reduced seedling quality, and resistance to stress conditions (Liou, 1987).

One important assessment of vigor is the longevity of seeds in storage (Roberts, 1986). A reduction in storage life is characteristic of seed deterioration. Research regarding the effects of storing primed seeds has been conflicting with some observations that storage does not affect the increased vigor associated with priming (Oluoch and Welbaum, 1994; Dearman et al., 1986; Atherton and Farooque, 1983) while other researchers report that primed seeds are more susceptible to deterioration during storage (Tarquis and Bradford, 1992; Argerich et al., 1989; Dearman et al., 1986). A theory has been advanced, referred to as the "metabolic repair hypothesis" that claims that the advancement in germination associated with priming is due to repair of previously sustained deterioration (Dearman et al., 1986; Ellis and Butcher, 1988). Burgass and Powell (1984), and Liou (1987), reported that priming improved seed quality of Brussels sprouts (*Brassica oleracea* var. *gemmifera*) and cabbage (*Brassica oleracea* var. *capitata*), respectively, after aging particularly with low vigor seeds. If primed seeds deteriorate more rapidly in storage, this would contradict the metabolic repair hypothesis.

Another critical component of seed vigor is seed quality. An ostensible characteristic of poor seed quality is split or damaged seed coats. Seed coat damage is a potential source of poor quality in *Brassica* spp. seeds (McCormac and Keefe, 1990). Seed coat splitting is caused by either mechanical impact during harvesting and handling, which usually results in complete rupture of the seed coat, or alternate wetting and drying of the mature seed while it is still in the field which creates growth cracks (Wolfe et al., 1979). Pill et al., (1994) discovered that the invigorating effect of priming *Amaranthus cruentus* L. seeds was most pronounced on the lower vigor, mechanically damaged seeds than high vigor seeds.

The objectives of this research were to investigate the protective capacity (priming seeds prior to storage) and the repair capacity (effects of priming on stored and damaged seeds) associated with priming of broccoli seeds.

Materials and Methods

Seed material and priming conditions. Seeds of cvs. 'Brigadier', 'Packman' (PetoSeed Co., Saticoy, CA) and 'Arcadia' (Sakata Seeds America, Salinas, CA) were used for this research. Seeds were primed osmotically using polyethylene glycol (PEG) solutions of -1.2 MPa, prepared according to Michel (1983) and verified with a vapor pressure osmometer (model 5100C, Wescor Inc., Logan, UT). Seeds (5 to 6 % moisture content, dw. basis) were placed on two thicknesses filter paper (Whatman no. 1) saturated with 7 ml·g⁻¹ seed in 8.5-cm² petri dishes. The petri dishes were sealed with parafilm (American National Can, Greenwich, Conn.) to prevent evaporation and placed in a dark incubator at 20°C for 7 d. After priming, the seeds were vigorously rinsed in tap water for 2 min followed by forced-air drying at 36°C for 20 min. The seeds were placed in a silica gel desiccator at room temperature (22°C; 45% RH) for 7 to 10 d until a final moisture content of 5 to 6% was reached (ISTA, 1986).

Effects of long-term storage on primed seeds. To test the effects of extended storage on primed broccoli seeds, seeds (cv. 'Packman') from a high vigor seed lot (>90% germination) were osmotically primed on 2 May 1990 as above. The seeds were redried to their initial moisture content of 5 to 6% and germinated at a stressful temperature (35°C). After drying, both primed and nonprimed seeds were placed in plastic bottles, tightly sealed, and placed in a cold storage room (4 ±1°C). After 4 years, the seeds were removed from storage, percent moisture content remeasured, and germinated again at 35°C.

Aging effects. The vigor of primed and nonprimed broccoli seeds was reduced by a accelerated aging. The initial moisture content of the seeds was determined by oven-drying at 102°C for approximately 17 h (ISTA, 1986). Three replications of 1 g each were raised to a final moisture content of 20% according to Matthews (1980). The equation:

$$\frac{(\text{Final Water Content (\% dry wt. basis)} \times \text{Initial Fresh Weight (g)})}{(100 - \text{Final-Water Content (\%)})} = \text{Water added} \quad (1)$$

was used to determine the amount of water required to raise the moisture content of each sample to 20% (A. G. Taylor, personal communication). The moisture content of the samples was verified by the oven method. The hydrated seeds were placed in 10x74 cm plastic tubes, wrapped in aluminum foil, and placed overnight in an incubator (5°C) to allow for moisture equilibration of all seeds. The following morning, the samples were placed in an isothermal water bath (45°C) for 48 h, and a standard germination test was performed at 25°C (Matthews, 1980). The germinated seedlings were transferred to 12x15 cm germination blotters saturated with distilled water on plexiglass slant boards, covered with plastic in a dark incubator (25°C). After 5 d, the number of abnormal seedlings, according to ISTA (1986) standards were counted.

Effects of priming on low quality seeds. Two separate experiments were performed to assess the effect of priming on germination performance of damaged or low quality seeds (Appendix Figure A.4). Three replications of 25 seeds each of cv. 'Packman' were divided into split and nonsplit seeds primed as above, and germinated at 25, 30 and 35°C. In another experiment, a seed lot of known low vigor (cv. 'Arcadia') determined from preliminary experiments, was selected for experimentation. Three replications of ten seed each with split seed coats were selected and removed from each seed lot and primed. 'Arcadia' were subjectively categorized as "moderately" and "severely" split. The

percentage of split seeds within each seed lot was determined. After germination, the seeds were transferred to blotters on plexiglass slant boards and seedlings evaluated for normal seedlings, hypocotyl and radicle length after 5 d at 25°C (ISTA, 1986).

Statistical analysis. Mean time to germination (MTG or T_{50}) was determined by converting cumulative germination to probits and plotting versus log (base 10) time. Final germination percentage and percent abnormal seedlings were arcsin transformed prior to statistical analysis.

Results and Discussion

After 4 years storage, the percent moisture content of primed and nonprimed seeds was 5.8% versus 6.9%, respectively. Primed seeds retained high vigor after storage for 4 years at 4°C even when germinated at supraoptimal temperatures (Table 8.1). Control, nonprimed seeds, however, exhibited a significant reduction in vigor after storage as shown by a 66% increase in the MTG of nonprimed seeds was observed. Storage or priming had no effect on final germination percentage. As observed with prairie grass spp., asparagus, tomato, spinach, muskmelon and onion seeds, storage at 4°C did not affect the enhanced vigor associated with priming (Atherton and Farooque, 1983; Burgass et al., 1986; Hardegree, 1994; Owen and Pill, 1994; Oluoch and Welbaum, 1994). Argerich et al., (1989) reported similar results for primed tomato seeds stored at 4°C, but seeds stored at 30°C, the positive attributes of priming were lost. Priming of stored, nonprimed seeds increased seed vigor to the same initial level as when they were primed 4 years earlier. Thus, any deterioration that occurred during storage of nonprimed seeds was seemingly reversed by priming. However, the effect of priming is more than just repair of any previously sustained damage. Priming of the high vigor seed lot before storage increased vigor more than that observed with the nonprimed, high vigor seeds (Table 8.1).

Table 8.1. Effects of osmotic priming broccoli seeds and long-term storage.

Treatment	Time^z	T₅₀ (h)	Germination (%)
Primed	1990	13.4	94
Primed	1994	10.1	89
Nonprimed	1990	26.7	87
Nonprimed	1994	66.7	94
Primed*	1994	19.2	94
<i>Significance</i>		<i>10.1</i>	<i>7.0</i>

^zTime (year) seeds were tested.

* Denotes priming 4-yr-old seed.

Similar to what was observed with stored, primed seeds, priming also increased the resistance to deterioration after accelerated aging (Table 8.2). Aging of primed seed increased the MTG by 31 h compared to 71 h for nonprimed, control seeds. The major effect of priming was to maintain viability and vigor of aged broccoli seeds. Aging significantly increased the number of abnormal seedlings (data not shown). Priming did not reduce the number of abnormal seedlings relative to nonprimed seeds. This suggests that priming may protect seed vigor after aging, but may have no significant effect on subsequent seedling growth.

All of the split seeds used in this study exhibited some degree of complete seed coat rupture. 'Packman' and 'Arcadia' had an average of 21% and 17% split seeds, respectively, within each seed lot. Split 'Packman' seeds had a significantly lower MTG compared with nonsplit seeds of the same lot without a concomitant reduction in viability or vigor indicating perhaps the damage did not extend to the embryo (Table 8.3). Priming of split seeds increased the germination rate more than priming nonsplit seeds at all temperatures.

The seed coat is a barrier to germination of broccoli seeds (cf. chapter 4). Priming results in irreversible expansion of the seed coat of broccoli seeds and also exacerbates the degree of splitting, perhaps making the seed coat less of a restraining force to the expanding embryo. McCormac and Keefe (1990) noted that split cauliflower (*Brassica oleracea* L. var. *botrytis*) seeds exhibited imbibition damage when imbibed at 20°C which reduced the rate of germination and subsequent seedling growth. Priming, by lowering the rate of influx of water into split seeds, may also act by reducing imbibition injury.

Nonsplit, nonprimed 'Arcadia' seeds had a 50% lower MTG compared to severely split seeds indicating possible embryo damage (Table 8.4). Priming severely split seeds resulted in a significantly lower MTG compared to nonprimed, nonsplit seeds. The invigoration enhancement may be the result of repair during priming or reducing the rate

of imbibition damage. Priming, regardless of the degree of splitting, did not affect final germination percentage. Split seeds, regardless of priming, had a large percentage of abnormal seedlings. Priming of moderately and severely split seeds did not decrease the percentage of abnormal seedlings, since priming cannot reverse the effects of damage (Figure 8.1).

Table 8.2. The effects of accelerated aging at 45°C for 48 h on primed broccoli seeds.

Treatment	Aged^z	T₅₀ (h)	Germination (%)
Primed	+	39.2	81
Primed	-	8.1	99
Nonprimed	+	99.4	67
Nonprimed	-	28.5	89
<i>F Significance</i>			
<i>Aging</i>		***	***
<i>Priming</i>		***	*
<i>Aging x Priming</i>		***	NS

^z+ presence or absence (-) of accelerated aging.

Table 8.3. Mean time to germination(T_{50}) of split seeds as a function of temperature.

Treatment	T_{50} (h)		
	25°C	30°C	35°C
Split, nonprimed	22.7	17.2	20.3
Split, primed	8.4	6.7	9.9
Nonsplit, nonprimed	21.3	20.1	23.6
Nonsplit, primed	10.9	10.8	15.2
<i>F Significance</i>			
<i>Temperature</i>	*	*	*
<i>Splitting</i>	*	*	*
<i>Priming</i>	***	***	***

Table 8.4. Effect of seed coat splitting on MTG (T_{50}) and % germination.

Treatment	T_{50} (h)	Germination (%)
Severely split, nonprimed	64.2	72.5
Severely split, primed	23.9	57.5
Moderately split, nonprimed	68.9	62.5
Moderately split, primed	39.9	70.0
Nonsplit, nonprimed	39.6	85.0
Nonsplit, primed	40.8	92.5
<i>F Significance</i>		
<i>Splitting</i>	NS	**
<i>Priming</i>	*	NS

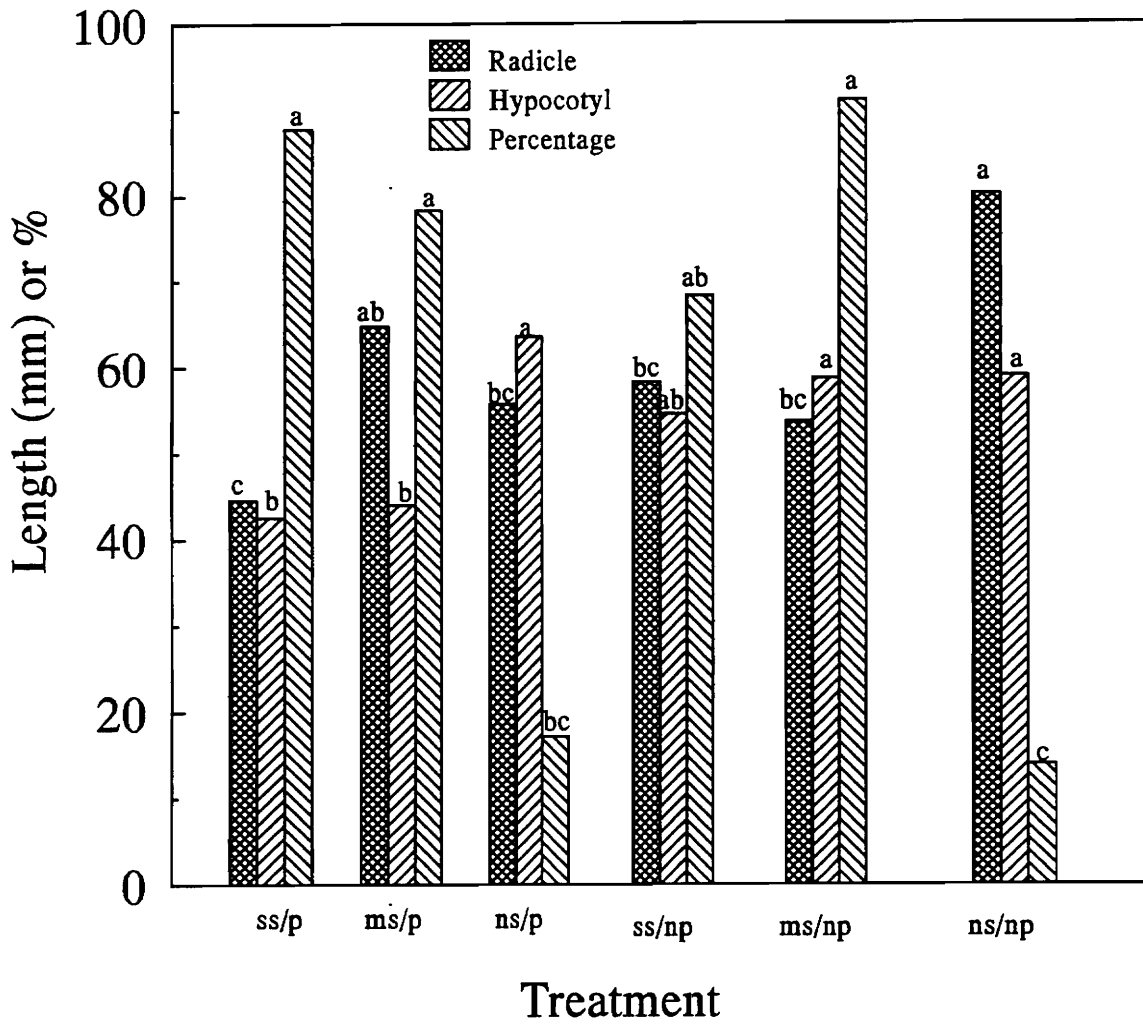

Figure 8.1. Radicle length, hypocotyl length, and percentage of abnormal seedlings of primed and nonprimed broccoli seedlings from split seeds. Bars with the same letter are not significantly different at $P \leq 0.05$. Abbreviations: **p**=primed; **np**=nonprimed; **ss**=severely split; **ms**=marginally split; **ns**=nonsplit.

Literature Cited

- Argerich, C. A., K. J. Bradford and A. M. Tarquis. 1989. The effects of priming and aging on resistance to deterioration of tomato seeds. *J. Exp. Bot.* 40:593-598.
- Atherton, J. G. and A. M. Farooque. 1983. High temperature and germination in spinach. II. Effects of osmotic priming. *Sci. Hort.* 19:221-227.
- Burgass, R. W. and A. A. Powell. 1984. Evidence for repair processes in the invigoration of seeds by hydration. *Ann. of Bot.* 53:753-757.
- Dearman, J., P. A. Brocklehurst, and R. L. K. Drew. 1986. Effects of osmotic priming and aging in onion seed germination. *Ann. Appl. Biol.* 111:717-722.
- Ellis, R. H. and P. D. Butcher. 1988. The effects of priming and natural differences in quality amongst onion seed lots on the response of germination to temperature and the identification of the characteristics under genotypic control. *J. Exp. Bot.* 39:950-953.
- Liou, T. D. 1987. Studies on germination and vigour of cabbage seeds. *Ph.D. Dissertation*, Agricultural University, Wageningen, The Netherlands pp 101.
- Matthews, S., 1980. Controlled deterioration: a new vigour test for crop seeds, pp. 647-660. In: *Seed Production* (P. D. Hebblethwaite, ed.) Butterworths, London.
- Michel, B. E. 1983. Evaluation of the water potentials of solutions of polyethylene glycol 8000 both in the absence and presence of other solutes. *Plant Physiol.* 72:66-70.
- Oluoch, M. and G. E. Welbaum. 1994. Effects of priming on muskmelon seed storability. *HortScience* 29:553 (Abstract).
- McCormac, A. C. and P. D. Keefe. 1990. Cauliflower (*Brassica oleracea* L.) seed vigour: imbibition effects. *J. Exp. Bot.* 41:893-899.
- Pill. W. G., T. A. Evans, and P. Krishnan. 1994. Priming improves germination and emergence of combine-harvested *Amaranthus cruentus* L. seeds. *HortScience* 29:655-658.

Roberts, E. H. 1986. Quantifying seed deterioration. *Physiology of seed deterioration*. (M. B. McDonald, and C. J. Nelson, eds.) C.S.S.A. Special Publication # 11. Crop Science Society of America, Inc., Madison, Wisconsin. pp. 101-123.

Chapter 9

Summary

Priming is a seed enhancement technique that improves the germination and emergence performance of broccoli (*Brassica oleracea* var. *italica* Plenck) seeds. Priming reduced the sensitivity of germinating seeds to temperature but did not lower the minimum temperature of germination (T_b). Priming maintained a constant, lower thermal time constant (θ_T) expressed as $^{\circ}\text{h}$, which means primed seeds make (or have already made) a greater progression towards at each temperature. Primed broccoli seeds germinated at higher temperatures than nonprimed seeds and thus expanded the temperature range for broccoli seed germination. Priming may act by stabilizing membranes at high temperature, since primed seeds leaked less electrolytes relative to nonprimed seeds at supraoptimal ($\geq 35^{\circ}\text{C}$) temperatures.

The positive effects of priming were preserved after storage for 4 years at 4°C while nonprimed seeds lost more vigor. Priming maintained viability and vigor after accelerated aging. Moreover, priming of stored (4°C) nonprimed broccoli seed increased the seed vigor to the same level as when they were primed 4 years earlier.

In the field, primed seeds emerged earlier and produced a greater stand of plants than nonprimed seeds. Under stressful seedbed conditions primed seeds resulted in earlier, larger yields, but under optimal conditions the advantages of primed seeds did not carry-over to earlier larger yields. Priming did not have an effect on seedling root or shoot growth beyond the initial advantage of earlier germination.

Matric priming of broccoli seeds using calcium silicate (Micro-cel E) in the ratio 1.0:0.8:1.8 (seed:carrier:water; by weight) for 7 d at 20°C was a more effective in improving germination rate than osmotic priming in polyethylene glycol (PEG 8000) at

-1.2 MPa. Seeds primed in calcium silicate had a higher rate of respiration during priming than seeds primed in polyethylene glycol which may account for the significantly greater germination performance of matric-primed seeds.

Priming altered the physical structure of broccoli seeds resulting in reversible and irreversible expansion of the embryo and testa, respectively. After primed seeds were dried to their initial moisture content, distinct free spaces were observed near the radicle and between the cotyledons which resulted in a 32 % increase in seed volume. The testa is a barrier to broccoli seed germination representing a restraining force of ≈ 0.45 MPa. Most broccoli seeds germinated by abrupt penetration of the radicle through the testa. The expansion of the testa during priming is preserved when the seed is redried. Environmental scanning electron microscopy of dried primed and nonprimed seeds revealed that priming resulted in an enlargement of testa epidermal cells. Also, minute cracking was observed with some seeds in the vicinity where the radicle emerges. Priming did not lower the minimum Ψ for germination (Ψ_b). In the absence of dormancy, it is not likely that a seed treatment such as priming would lower the minimum Ψ for germination.

Instron analysis indicated that dry primed seeds had a weaker testa than dry nonprimed seeds. However, at 1 h before germination, the restraining force did not differ between primed and nonprimed seeds. Primed seeds make a greater progression towards germination per unit MPa, as observed by a constant, lower hydrotime constant (θ_H) possibly as a result of an already weakened and irreversibly expanded testa.

Despite the reduced integrity of the testa and greater volume of primed seeds, priming did not result in a greater rate of imbibition or water content at full hydration. Primed seeds moved from imbibition to expansive growth with no detectable lag phase. At full hydration, primed seeds did not have a greater turgor than nonprimed seeds; but they did

have a significantly greater nonsymplastic (apoplastic) volume, possibly as a result of the increased volume that is preserved upon redrying.

The enhancement in germination rate by priming can be quantified by accumulation of hydropriming units expressed as MPa·h. The minimum Ψ that produced a priming effect was -2.5 MPa. Priming at -1.2 MPa for 7 d resulted in the accumulation of 218 MPa·h, which resulted in the largest increase in germination rate. Thus, a priming effect can be attained if 218 MPa·h are accumulated by broccoli seeds at 20°C .

Maximum broccoli seed dry weight was attained at 42 d after pollination (DAP), with maximum germination rate and viability observed at ≥ 49 DAP. Priming significantly improved germination rate and viability at all stages of seed development, with the most significant effects observed before attainment of maximum dry weight. This indicates that priming does not solely act as a repair mechanism, since undamaged, immature seeds exhibited increased vigor after priming. Large seeds did not germinate faster than small seeds. Priming of small seeds did not result in a significantly greater vigor relative to large seeds, but large seeds produced larger seedlings. Dry storage of seeds at harvestable maturity (≥ 56 DAP) did not significantly improve the germination rate. These facts suggest that the enhancement in vigor associated with priming is related to morphological or physiological development before physiological maturity (42 DAP) but not substituting for an after-ripening requirement of mature (≥ 56 DAP) broccoli seeds.

Appendix

Table A.1. Micro and macro nutrient content of calcium silicate used to prime broccoli seeds.

<u>Macronutrients</u>				<u>Micronutrients</u>				
(ppm)				(ppm)				
P	K	Ca	Mg	Zn	Mn	Cu	Fe	B
15.5	33	1200	31	0.3	1.4	0.1	0.7	0.5

Table A.2. Percent germination of broccoli seeds primed in two molar (M) concentrations of KNO_3

Treatment	Germination (%)
0.45M	0
0.49M	0

Table A.3. Emergence of matric primed and osmotic primed seeds in the greenhouse.

Treatment	MTE	Emergence
	(h)	(%)^z
Matric primed	61.6	98
Osmotic primed	75.3	92
Nonprimed	97.9	87
<i>LSD</i> (0.05)	5.9	5

^zPercentage data arcsin transformed prior to analysis.

Table A.4. Summary of harvest data using cv. 'Earlidawn' in southern VA (1990).

Treatment ^z	Harvests (number harvested/date) ^y				% of total in first two harvests	% harvested by 11/26 ^x
	11/5	11/13	11/20	11/26		
Primed	3	13	13	8	54.3	100
Nonprimed	1	4	7	7	21.6	81.6
<i>Significance</i>					**	**

^zMeans of three replications.

^yOne-hundred seeds sown.

^xProjected date for lethal freeze in southern VA.

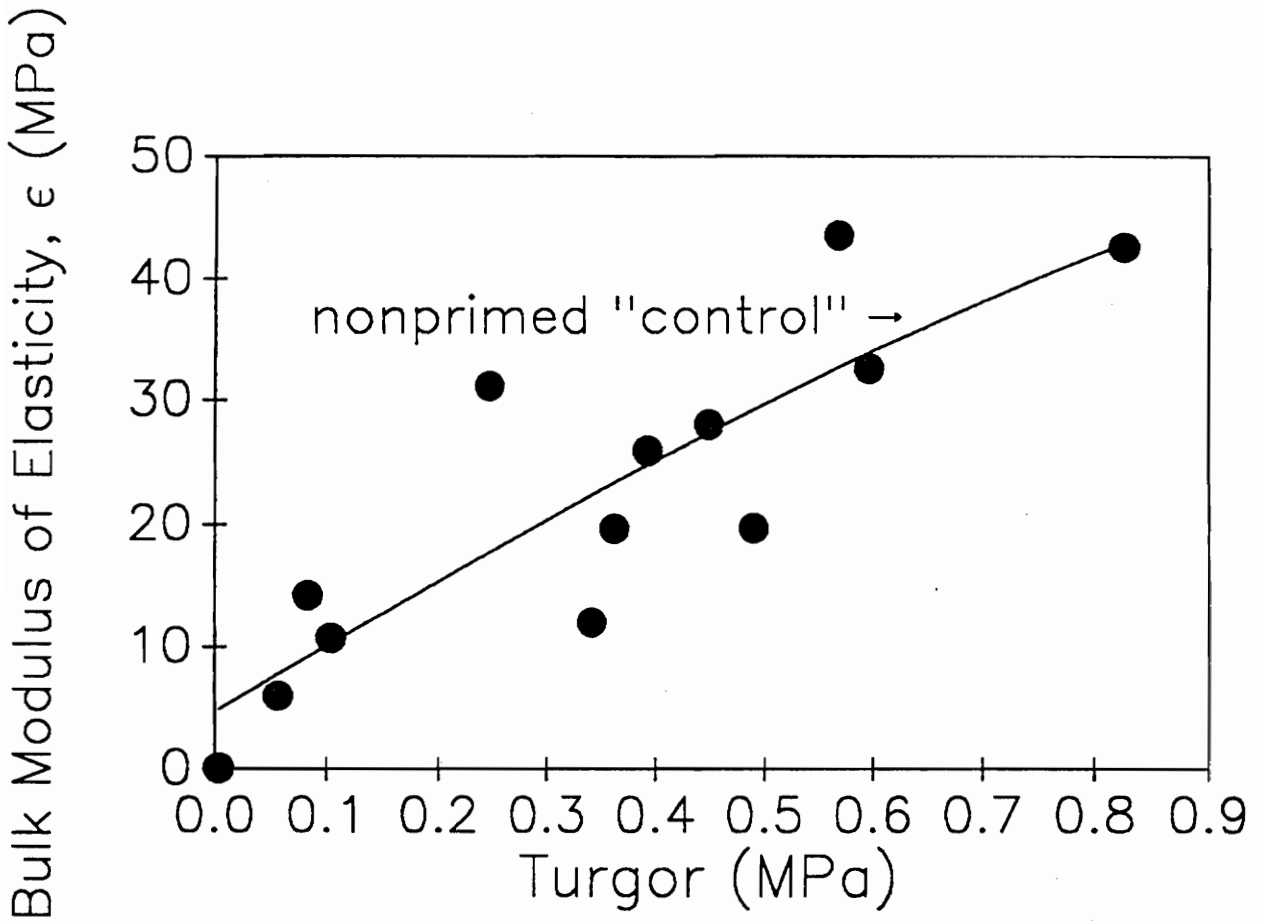

Figure A.1. Bulk modulus of elasticity (ϵ) of nonprimed broccoli seeds. The value ϵ is calculated as $\epsilon = (dP/dv) \cdot v$, where P is turgor and v is cell volume. The more elastic the cell wall, the smaller the value of ϵ (Tyree and Jarvis, 1982). The elastic modulus of nonprimed seeds appeared linear with maximum values of 50 MPa at 0.8 MPa turgor. The regression equation here is: $y = 55.95 - 11.58x$ ($r^2 = 0.75$).

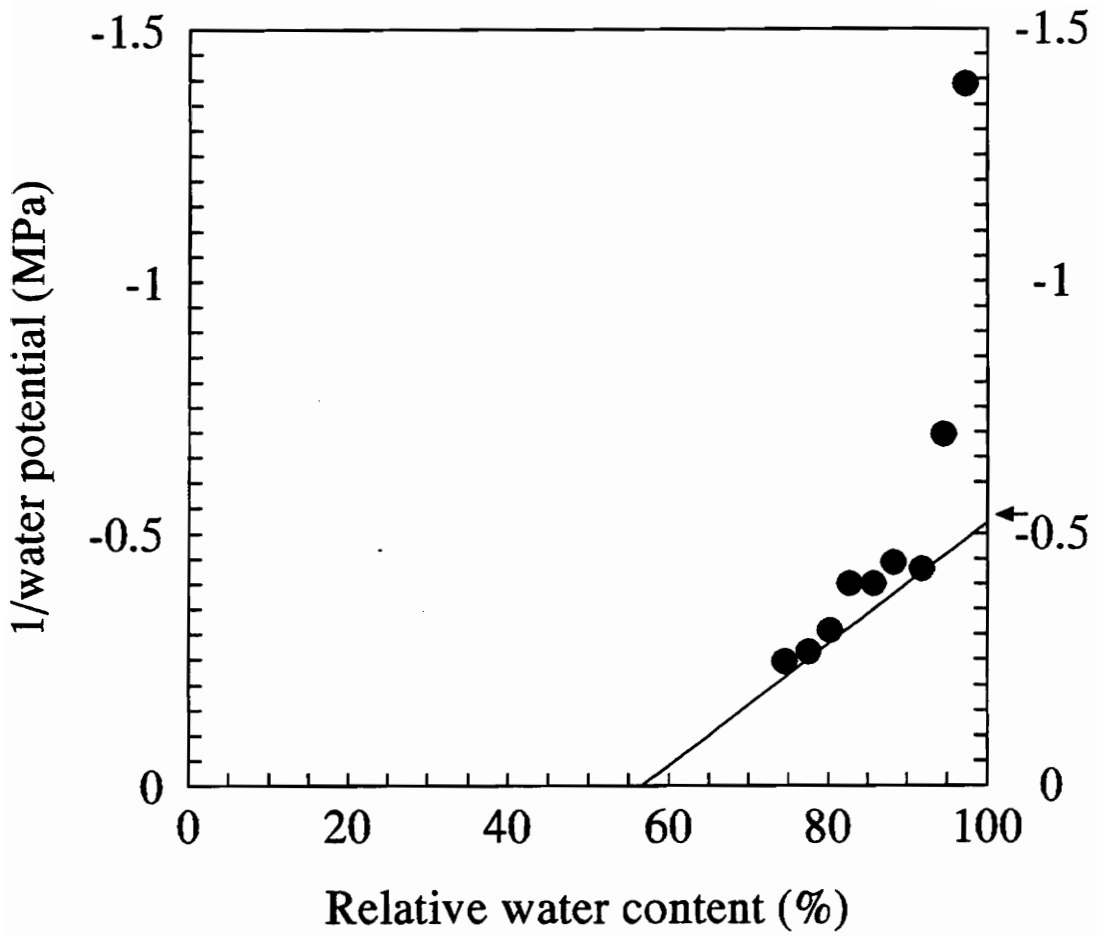

Figure A.2. Representative water potential isotherm for matric-primed broccoli seeds. Arrow indicates osmotic potential at full hydration.

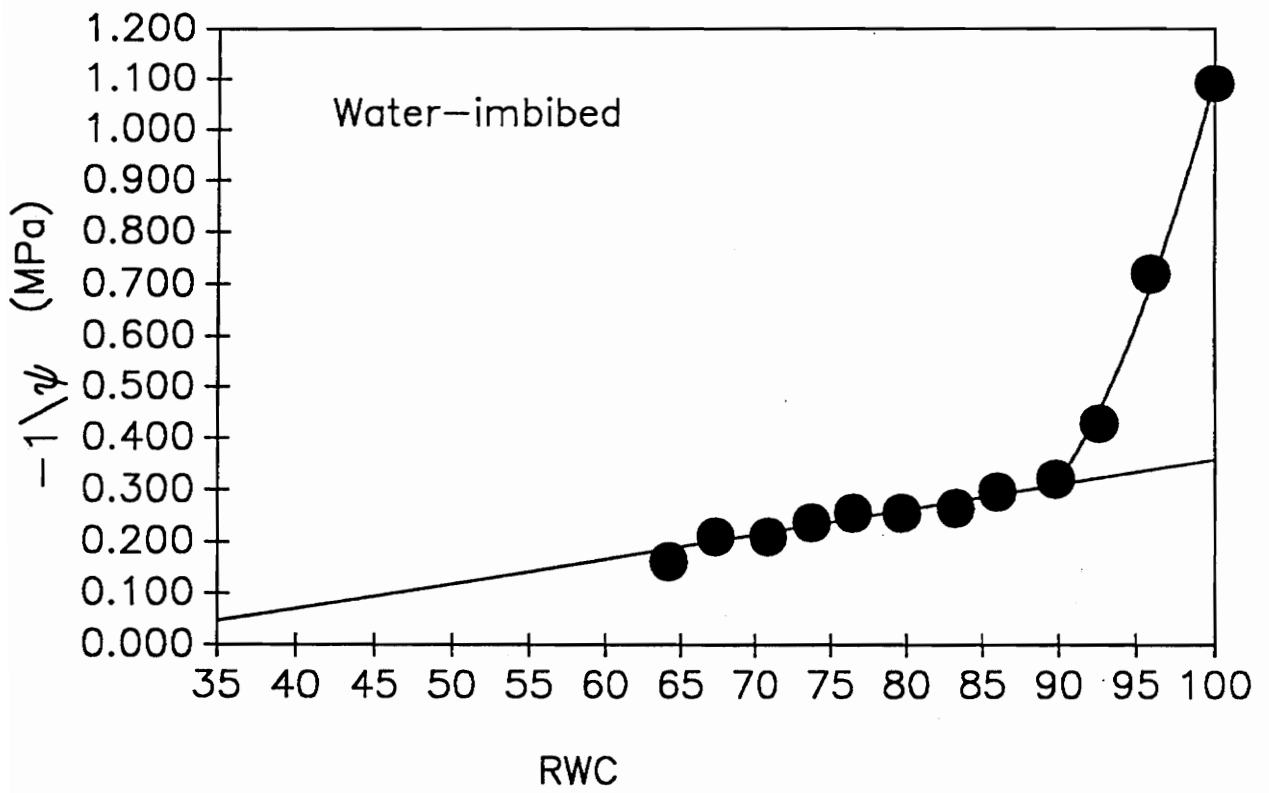

Figure A.3. Water potential isotherm for water-imbibed (6 h at 20°C) broccoli seeds.



Figure A.4. Characteristic severe splitting of broccoli seeds (cv. 'Arcadia').

Vita

Lewis Jett was born and raised on a farm in Lost Creek, West Virginia, the son of William and Pauline Jett. He has a sister, Martha and a brother, William. He has been a commercial grower of small fruits (strawberries) and vegetables since 1982. He completed his Bachelor of Science in Agricultural Economics from West Virginia University in 1987, a Master's of Science in Horticulture from Virginia Tech in 1990, and a Ph.D. in Horticulture from Virginia Tech in 1994.

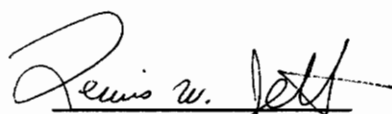

Lewis W. Jett