

The Age-Related Effects of Visual Input on Multi-Sensory Weighting  
Process During Locomotion and Unexpected Slip Perturbations

Manutchanok Jongprasithporn

Dissertation submitted to the faculty of the Virginia Polytechnic Institute  
and State University in partial fulfillment of the requirements for the degree  
of

Doctor of Philosophy

In

Industrial and Systems Engineering

Thurmon E. Lockhart, Chair

Brian M. Kleiner

Karen A. Roberto

Robert H. Sturges

September 9, 2011

Blacksburg, VA

Keywords: Age, Slips and Falls, Temporary loss of visual input, Walking

# The Age-Related Effects of Visual Input on Multi-Sensory Weighting Process During Locomotion and Unexpected Slip Perturbations

Manutchanok Jongprasithporn

## ABSTRACT

Falls are the leading cause of fatal and non-fatal injuries among older adults. Age-related sensory degradation may increase instability and increase the risk of slips and falls in older adults. The integration of three sensory systems (visual, proprioceptive, and vestibular systems) and the respective weighting of each are needed to maintaining balance during unexpected slip-induced falls. The visual system is often thought of as the most important sensory system in playing a major role in stabilizing posture, guiding locomotion and controlling slip response. However, previous studies have focused on the age-related effects of visual input on static postural stability. The age-related effects of visual input associated with locomotion and unexpected slip perturbations (i.e., dynamic tasks) remains unclear.

The purpose of this study is to investigate the age-related effects of visual input on multi-sensory processing during locomotion and unexpected slip perturbations. Fifteen young and fifteen old adults were recruited to participate in this study. Motion capture system, force plate, and EMG data were collected during the experiments. Various biomechanical and neuromuscular characteristics were identified to quantify the age-related effects of visual input during locomotion and unexpected slip perturbations. The results indicate that temporary loss of visual input during walking could cause individuals to adopt a more cautious gait strategy to compensate for their physical and neuronal changes as shown in increased double support time and higher co-contraction (i.e., stiffness) of the knee and ankle joints. Older adults also have higher co-contraction at the ankle joint during walking as compared with young adults.

Regarding slip-induced falls, temporary loss of visual input causes increased slip distances and response times of upper and lower limbs in both younger and older groups. In terms of kinematics, the combination of age and temporary loss of visual input influenced the perturbed limb. In terms of muscle activation patterns, temporary loss of visual input may increase the proprioceptive gain as shown in early muscle activity onset, increased muscle activation duration, and increased co-contraction at the knee joint. However, stiffness may increase the difficulty to detect a slip event and reduce flexibility and increase slip-induced falls

Although the human body cannot fully compensate for the temporary loss of visual input, the results in this study suggest that the reweighting process increases proprioceptive gain while visual input is unavailable. These findings support the implication of future research in order to understand the potential hazards which could occur while walking and slipping with temporary loss of visual input. The results may also contribute to the design of effective interventions to improve motor learning by applied visual occlusion in slips/falls training to reduce fall risk and enhance safety. The visual occlusion paradigm may assist to increase learning encoded in intrinsic coordination, related to motor performance skill, providing the flexibility required to adapt to complex environments such as slip-induced falls.

## ACKNOWLEDGEMENTS

I am extremely thankful to my major advisor, Dr. Thurmon E. Lockhart, for his guidance throughout this research, and the freedom to conduct this research in a way that allowed me to further my development both academically and professionally. I am grateful to him for sharing his knowledge, expertise and skills with me, and I really appreciate his patience, confidence and optimism that I needed and looked for during the past few years. It is my great pleasure to also acknowledge and thank my committee members, Dr. Brian M. Kleiner, Dr. Karen A. Roberto and Dr. Robert H. Sturges, for their comments, criticism, and varied perspectives.

Special thanks go to my fiancé, Dr. Nantakrit Yodpijit, for believing in me. Thanks for never letting me give up and always encouraging me. I cannot make it without his greatest support. When I am weak, he makes me strong. Thank you again to be with me and help me get through the hard times in my life. Many thanks also go to my locomotion lab friends, Xiaoyue Zhang, Rahul Soangra, Xuefang Wu, and Han Teik Yeoh for data collection and my great friends at Virginia Tech, Courtney A. Haynes and Jay E. Clasing for his time on proofreading. I also would like to thank you Mr. Will Vest for your technical support throughout my research. I would like to extend a very special thank you to my Blacksburg family, Prof. Clifford and Phyllis Randall, for their love, hugs, and support. Thank you to Associate Prof. Pornsak Attavanich and Dr. Sunpasit Limnararat from KMITL, Thailand for giving me an opportunity to study in the U.S. and their great support throughout my journey. I could not have completed this dissertation without financial support from the Royal Thai Government.

Finally, I owe thanks to my parents and family. Thank you Mom, Srisomporn and Dad, Associate Prof. Somkiat Jongprasithporn for your unconditional love, support, and encouraging me to pursue my dream. Dad, thank you for being a great role model for me. Mom, your believing in me has allowed me to be a better person I am today. Mom always said that “I believe in you and you can do it, my daughter”. Although mom could not be with me anymore, her belief and her unconditional love will be with me forever. I love you Mom and Dad.

# TABLE OF CONTENTS

<b>List of Figures</b> .....	viii
<b>List of Tables</b> .....	xi
<b>Chapter 1 Introduction</b> .....	<b>1</b>
1.1 Rationale.....	1
1.2 Specific Aims and Hypotheses.....	2
1.3 Relevance for the Study .....	4
<b>Chapter 2 Background and Significance</b> .....	<b>5</b>
2.1 Epidemiology of Falls in Older Adults .....	5
2.2 Mechanics of Slips and Falls.....	6
2.2.1 Before Initial slip.....	6
2.2.1.1 Coefficient of Friction.....	6
2.2.1.2 Gait Characteristics .....	7
2.2.2. After Initial Slip .....	8
2.2.2.1 Age-Related Declines of the Nervous Systems.....	8
2.3.2.2 Age-Related Declines of the Sensorimotor Integration .....	13
2.3.2.3 Age-Related Declines of the Skeletal Muscles .....	14
2.4 Occurrence of Critical Slip Events and Response Time of Sensory Systems....	15
2.5 Slip Recovery Processes.....	16
2.5.1 Muscle Activation .....	17
2.5.2 Muscle Co-Contraction . .....	18
<b>Chapter 3 STUDY I – The Age-related effects of Visual Input on Automatic Postural Muscle Response During Human Locomotion</b> .....	<b>20</b>
3.1 Objective .....	20
3.2 Participants.....	20
3.2.1 Sample Size Estimates .....	20
3.2.2 Screening Test .....	21
3.3 Apparatus .....	22
3.4 Protocol Study I .....	26

3.5	Data Analyses.....	27
3.6	Experimental Design.....	27
3.6.1	Independent Variables.....	28
3.6.2	Dependent Variables.....	29
3.6.2.1	Friction Demand.....	29
3.6.2.2	Gait Parameters.....	30
3.6.2.3	Postural Adjustments.....	31
3.6.2.4	Muscle Co-Contraction.....	34
3.7	Statistical Analyses.....	36
3.8	Results.....	36
3.8.1	Required Coefficient of Friction (RCOF) and walking velocity.....	36
3.8.2	Gait Parameters.....	37
3.8.3	Postural Adjustments.....	41
3.8.4	Muscle Co-Contraction.....	44
3.9	Discussion.....	46
<b>Chapter 4 STUDY II – The Age-related effects of Visual Input on Biomechanical Changes During Unexpected Slip Perturbations.....</b>		<b>52</b>
4.1	Objective.....	52
4.2	Participants.....	52
4.2.1	Sample Size Estimates.....	52
4.3	Apparatus.....	53
4.4	Protocol Study II.....	54
4.5	Data Analyses.....	55
4.6	Experimental Design.....	55
4.6.1	Independent Variables.....	56
4.6.2	Dependent Variables.....	57
4.6.2.1	Slip Severity.....	57
4.6.2.2	Postural Adjustments.....	59
4.6.2.3	EMG Measures.....	60
4.6.2.4	Response Time associated with Slip Events.....	63
4.7	Statistical Analyses.....	66

4.8	Results .....	66
4.8.1	Required Coefficient of Friction (RCOF) and walking velocity.....	66
4.8.2	Slip Severity.....	67
4.8.3	Response Time associated with Slip Events .....	70
4.8.4	Postural Adjustments.....	79
4.8.5	EMG Muscle Activation Patterns .....	83
4.8.6	Frequency of actual Falls .....	88
4.9	Discussion .....	93
<b>Chapter 5 – Summary and Conclusion.....</b>		<b>101</b>
5.1	Summary .....	101
5.2	Limitations and Future Recommendations .....	104
5.3	Conclusion.....	105
REFERENCES .....		107
Appendix A- PALTO Connection and Location Diagram .....		115
Appendix B- Medical History Form.....		116
Appendix C- Vision Screening Tests.....		119
Appendix D- Consent Form.....		120

## LIST OF FIGURE

Figure 2.1 The process of initiation, detection, and recovery of inadvertent slips and falls with possible causes and effects .....	6
Figure 2.2 The RCOF during the heel-contact phase in normal level walking .....	7
Figure 2.3 The multiple impairments associated with slips and falls in older adult.....	8
Figure 2.4 Visual information associated with locomotion.....	10
Figure 2.5 Occurrence of critical slip events and response time of visual, proprioceptive, and vestibular systems .....	15
Figure 3.1 The Bausch & Lomb Vision Tester.....	22
Figure 3.2 Experimental set up including two force plates, motion capture system, and glasses controller set .....	23
Figure 3.3 The glasses controller set and PLATO: Portable Liquid-crystal Apparatus for Tachistoscopic Occlusion .....	24
Figure 3.4 The trigger detects right lower limb swing before heel-contact event .....	24
Figure 3.5 Example of the association of signal profile from the controller set (volts) and vertical force profile during heel-contact event ... ..	25
Figure 3.6 A participant with completed markers, EMG electrodes, and PLATO .....	26
Figure 3.7 Gait associated with the first step and next step after visual occlusion .....	30
Figure 3.8 A person's footprints associated with Step width (SW) and Step length (SL) ... ..	31
Figure 3.9 Timing of single and double support during one gait cycle .....	31
Figure 3.10 The posture model describes the position of the body segments with the following angles on the sagittal plane.....	32
Figure 3.11 Mean and S.D. of (a) first step length (FSL), (b) first step width (FSW), (c) first step duration (FSD), and (d) first double support time (FDST) between age groups.....	38
Figure 3.12 Mean and S.D. of (a) first step length (FSL), (b) first step width (FSW), (c) first step duration (FSD), and (d) first double support time (FDST) between NWV and NWOV .....	38
Figure 3.13 Mean and S.D. of (a) next step length (NSL), (b) next step width (NSW), (c) next step duration (NSD), and (d) next double support time (NDST) between age groups .....	39



Figure 3.14 Mean and S.D. of (a) next step length (NSL), (b) next step width (NSW), (c) next step duration (NSD), and (d) next double support time (NDST) between NWV and NWOV.....	39
Figure 3.15 Mean plot of next double support time between age groups (Young vs. Old) and visual conditions (NWOV vs. NWV) during normal walking.....	40
Figure 3.16 Mean and SD of next double support time between age groups (Young vs. Old) and visual conditions (NWOV vs. NWV) during normal walking .....	40
Figure 3.17 Joint angles at heel-contact during NWV vs. NWOV.....	42
Figure 3.18 Example of joint angles normalized from HC to TO .....	43
Figure 3.19 Integrated CCI of the knee and ankle joints at HC, MS, and TO for (a) age groups and (b) visual conditions.....	44
Figure 3.20 Integrated CCI of the knee and ankle joints at HC, MS, and TO for Young NWV, Young NWOV, Old NWV, and Old NWOV.....	45
Figure 3.21 A foot position diagram associated with the concept of ballistic strategy ....	47
Figure 3.22 Schematic diagram of the basic human control associated with adaptive and strategic controller during walking.....	48
Figure 4.1 Composite view of the heel dynamics during a slip response on the slippery floor.....	58
Figure 4.2 The posture model describes the position of the body segments with the following angles on the sagittal plane.....	59
Figure 4.3 Example of muscle EMG activity during normal walking and normal ensemble average profile during stance phase (HC to TO).....	61
Figure 4.4 Example of perturbed foot response time during slip. ....	64
Figure 4.5 Example of unperturbed foot response time during slip .....	65
Figure 4.6 Example of arm response time during slip.....	65
Figure 4.7 Slip distances (SDI, SDII and SDIII) for (a) age groups and (b) visual conditions.....	68
Figure 4.8 Means and standard deviations of SHV and PSHV for Young SWV, Young SWOV, Old SWV, and Old SWOV .....	68
Figure 4.9 Relationship between walking velocity and SDI of each participant.....	69
Figure 4.10 Relationship between walking velocity and SHV of each participant .....	69
Figure 4.11 Relationship between walking velocity and PSHV of each participant.....	70
Figure 4.12 Perturbed foot response time (slip-start, slip-middle, slip-peak and slip-stop) for (a) between age groups and (b) between visual conditions.....	71

Figure 4.13 Example of perturbed (a) heel acceleration and (b) heel velocity during SWV and SWOV .....	73
Figure 4.14 Unperturbed foot response time (slip toe-off, foot-onset, and foot-down) (a) for younger and older groups and (b) for four groups (Young SWV, Young SWOV, Old SWV, and Old SWOV).....	74
Figure 4.15 Example unperturbed (a) toe position and (b) toe velocity during SWV and SWOV .....	75
Figure 4.16 Means and standard deviations of arm response time for Young SWV, Young SWOV, Old SWV, and Old SWOV .....	77
Figure 4.17 Example of (a) jerk and (b) velocity of perturbed arm and unperturbed arm (perturbed arm SWV, unperturbed arm SWV, unperturbed arm SWOV and unperturbed arm SWOV) during unexpected slip perturbation.....	78
Figure 4.18 Peak joint angles (ankle, knee, hip, and trunk) (a) for younger and older groups and (b) for visual condition .....	80
Figure 4.19 Mean plot of peak hip flexion between age groups (Young vs. Old) and visual conditions (SWOV vs. SWV) .....	80
Figure 4.20 Mean and S.D. of peak hip flexion for four conditions (Young SWV, Young SWOV, Old SWV, and Old SWOV).....	80
Figure 4.21 Joint angular velocities during slip with (a) SWV vs. SWOV and (b) Young vs. Old.....	81
Figure 4.22 Example of (a) ankle, (b) knee, (c) hip and (d) trunk joint angle during slip with visual input (SWV) and slip without visual input (SWOV).....	83
Figure 4.23 Muscle activation onset (a) between Young vs. Old and (b) during slip with visual input (SWV) and slip without visual input (SWOV).....	84
Figure 4.24 Duration of muscle activity (a) between Young vs. Old and (b) during slip with visual input (SWV) and slip without visual input (SWOV).....	85
Figure 4.25 Example of EMG activities (onset and offset) during slip with visual input (SWV) and slip without visual input .....	86
Figure 4.26 Integral muscle co-contraction index (CCI) at the knee and ankle joints (a) age groups and (b) during SWV and SWOV.....	87
Figure 4.27 Occurrence of critical events after slip-start (Time at zero indicates heel-contact).....	89
Figure 4.28 Kinematics and muscle activation composite profile after slip initiation .....	92
Figure 4.29 Schematic diagram of the basic human control associated with adaptive and strategic controller during unexpected slip perturbations.....	94

## LIST OF TABLES

Table 3.1 Summarizes the required sample size for detecting significant differences between walking with visual input and without visual input, given $\alpha = 0.05$ and $\beta = 0.20$ .....	21
Table 3.2 Mean and S.D. of participants' age, weight and height .....	21
Table 3.3 Mean and S.D. of gait parameters during walking with and without PLATO .	25
Table 3.4 The experimental design matrix for study I.....	28
Table 3.5 Source and Error terms for mixed-factor ANOVA .....	29
Table 3.6 Mean $\pm$ S.D. of gait parameters during NWV and NWOV trials between young and old groups.....	37
Table 3.7 Mean $\pm$ S.D. of gait parameters during NWV and NWOV trials between young and old groups.....	41
Table 3.8 Mean $\pm$ S.D. of joint angles and angular velocities during SWV and SWOV between younger and older groups .....	42
Table 3.9 Mean $\pm$ S.D. of muscle co-contraction during NWV and NWOV trials between young and old groups.....	45
Table 4.1 Summarizes the required sample size for detecting significant differences between slip with visual input and without visual input given $\alpha = 0.05$ and $\beta = 0.30$ . .....	53
Table 4.2 The experimental design matrix for study II .....	55
Table 4.3 Source and Error terms for mixed-factor ANOVA .....	57
Table 4.4 Mean $\pm$ S.D. of gait parameters during SWV and SWOV trials between young and old groups.....	67
Table 4.5 Mean $\pm$ S.D. of slip parameters during SWV and SWOV trials between young and old groups.....	70
Table 4.6 Mean $\pm$ S.D. of perturbed foot response time during SWV and SWOV trials between age groups.....	72
Table 4.7 Mean $\pm$ S.D. of unperturbed foot response time during SWV and SWOV trials between age groups.....	74
Table 4.8 Mean $\pm$ S.D. of unperturbed foot response time during SWV and SWOV trials between age groups.....	77
Table 4.9 Mean $\pm$ S.D. of joint angles and angular velocities during SWV and SWOV between younger and older groups .....	82

Table 4.10 Mean $\pm$ S.D. of onset and duration of muscle activity during SWV and SWOV between younger and older groups .....	86
Table 4.11 Mean $\pm$ S.D. of integral CCI during SWV and SWOV between younger and older groups .....	88

## CHAPTER 1

### Introduction

#### 1.1 Rationale

Falls are one of the most serious accidents leading to increased unintentional injuries and mortality (CDC, 2010). In 2007, there were 23,443 fatal and 8.06 million non-fatal fall related injuries for all age groups. The fatal falls in older adults account for 81 percent of fatal falls for all ages. In 2009, there were 2.2 million nonfatal fall injuries among older adults, treated in emergency department and over 581,000 of these patients were hospitalized. Falls are not only the cause of suffering and functional impairments to the individuals, but also the cause of increasing medical cost and days away from work (Leamon & Murphy, 1995; Roudsari, Ebel, Corso, Molinari, & Koepsell, 2005; Stevens, Corso, Finkelstein, & Miller, 2006). As such, falls are a significant problem to our society both in terms of human suffering and economic losses.

Falls are a result of a complex interaction of various risk factors which are modified by age, pathology, and environmental hazards (Fleming & Pendergast, 1993). Sensory inputs, including the visual, proprioceptive, and vestibular systems are redundant and relevant for balance maintenance (Lockhart, Smith, & Woldstad, 2005; Woollacott, Shumway-Cook, & Nashner, 1986). Decreasing stability with increasing age is due to sensory degradation (Lockhart, 2008; Lockhart, et al., 2005). The postural control system uses each sensory system separately as well as integrative manner whereby sensory systems are reweighted to maintain stability in challenging conditions (e.g., slippery surfaces) (Nashner, 1976; Oie, Kiemel, & Jeka, 2002). Weighting refers to the process by which the central nervous system relies on a particular sensory system in a given situation (Bent, McFadyen, & Inglis, 2005). The unexpected loss of visual input during locomotion and slip events may cause sensory weighting process to adjust toward available yet limited input, and may cause postural instability (as measured by change in muscle activation pattern, and reaction/response times) and increase the likelihood of falls.

There are several circumstances that may influence visual input in everyday life. For instance, visual dependent behavior among older individuals may cause them to rely on visual input that may be inaccurate or unreliable to use in regaining balance (Allison, Kiemel, & Jeka,

2006; Simoneau et al., 1999; Sundermier, Woollacott, Jensen, & Moore, 1996; Wade, Lindquist, Taylor, & Treat-Jacobson, 1995). Additionally, from a clinical perspective, multifocal glasses may pose inaccurate lower visual field during locomotion (Lord, 2006; Lord, Dayhew, Sc, & Howland, 2002). Finally, periodic absence of visual input during locomotion is a common and challenging activity that can occur during working and daily tasks, for example, carrying loads (C. J. Perry et al., 2010).

In summary, the sensory degradation in older adults may increase the time taken to reweight the multi-sensory systems during slip-induced falls, and increase the risk of falls (Teasdale & Simoneau, 2001). The proposed research is to investigate the age-related effects of visual input on multi-sensory process during locomotion and unexpected slip perturbations to ascertain the influence of sensory-weighting mechanism associated with slip induced falls in elderly persons.

## 1.2 Specific Aims and Hypotheses

**Specific Aim 1:** To determine the effects of age on gait parameters, postural control and muscle activation patterns associated with a visual perturbation at the heel-contact during normal walking. Two visual conditions include: 1) continuous visual input and 2) unexpected visual perturbation (loss of visual input) at the heel-contact phase of the gait cycle.

*Hypothesis 1a:* The gait parameters, joint angles, and integrated co-contraction index (Int CCI) will be different when exposed to unexpected loss of visual input at the heel-contact during normal walking as compared to normal walking with continuous visual input.

*Hypothesis 1b:* The gait parameters, joint angles, and integrated co-contraction index (Int CCI) for older adults when exposed to unexpected loss of visual input the heel-contact will be different as compared to their younger counterparts.

In this study, normal walking with continuous visual input and unexpected visual perturbation at the heel-contact were constrained respectively. The specific methods are further elaborated in the Chapter 3. Four categories of parameters were assessed in this study. Gait

parameters include step length (SL), step width (SW), walking speed (WS) and double support time (DST) at the first step and at the next step. Joint angles include perturbed shoulder, unperturbed shoulder, trunk, hip, knee, and ankle angles. Additionally, friction demand was represented by the required coefficient of friction (RCOF). Finally, integrated co-contraction index (Int CCI) of the antagonist/agonist (Tibialis Anterior, TA/ Medial Gastrocnemius, MG and Vastus Lateralis, VL/ Medial Hamstring, MH) muscle pairs represents the stiffness at the knee and ankle joints.

**Specific Aim 2:** To evaluate the effect of age on the slip severity, postural adjustments, muscle activation patterns, and response time(s) changes associated with visual perturbation while undergoing a slip-induced fall. Two visual conditions include: 1) continuous visual input and 2) unexpected visual perturbation (loss of visual input) at the heel-contact.

*Hypothesis 2a:* The slip severity, joint angles, muscle activation patterns, integrated co-contraction index (Int CCI), and response time(s) when exposed to an unexpected slip perturbation with continuous visual input as compared to that with unexpected loss of visual input will be significantly different within individuals.

*Hypothesis 2b:* The slip severity, joint angles, muscle activation patterns, integrated co-contraction index (Int CCI), and response time(s) for older adults when exposed to an unexpected slip perturbation with continuous visual input and unexpected loss of visual input will be different as compared to their younger counterparts.

In this study, slip perturbation with continuous visual input and unexpected visual perturbation at the heel-contact were further evaluated. The specific methods are discussed in the Chapter 4. Five categories of parameters were assessed in this study. Slip severities include slip distance I (SDI), slip distance II (SDII), slip distance III (SDIII), sliding heel velocity (SHV), and peak slide heel velocity (PSHV). Joint angles were included perturbed shoulder, unperturbed shoulder, trunk, hip, knee, and ankle angles. Muscle activation patterns included muscle onset and offset time at Vastus Lateralis (VL), Medial Hamstring (MH), Tibialis Anterior (TA) and Medial Gastrocnemius (MG). Integrated co-contraction index (Int CCI) of the antagonist/agonist (TA/MG and VL/MH) muscle pairs represents stiffness at the knee and ankle joints during slip

perturbation. Finally, response time(s) included perturbed foot, unperturbed foot, perturbed side arm, and unperturbed side arm response time(s).

### **1.3 Relevance for the Study**

This study is to provide a better understanding of the mechanism of age-related effects on postural control strategies, muscle activation patterns and response time(s) associated with visual perturbations during locomotion and slip-induced falls. The results from this study are expected to be beneficial in understanding human behavior to reduce falls during temporary loss of visual input and designing effective interventions to reduce fall risk and enhance safety. The interventions can be applied to older and younger adults who rely heavily on visual input to enhance occupational safety during walking and carrying loads. The training program which occludes visual input during slip perturbations, may assist to enhance the weighting process to available inputs (proprioceptive and vestibular systems).



## CHAPTER 2

### Background and Significance

#### 2.1 Epidemiology of Falls in Older Adults

Falls are the leading cause of mortality among older adults. Non-fatal falls also result in reduced function and poor quality of life among older adults (CDC, 2010). In 2007, there were 23,443 fatal and 8.06 million non-fatal fall related injuries for all age group. In regard to the aging population (65 years and over), there were 18,444 fatal and 1.93 million non-fatal fall injuries. With the aging of the Baby Boomers, the number of persons aged 65 and older is expected to more than double, from 38.7 million to 88.5 million between 2008 and 2050 (U.S. Census Bureau, 2008). Slipperiness contributes to between 40 and 50 percent of fall-related injuries (Courtney, Sorock, Manning, Collins, & Holbein-Jenny, 2001). Among older adults, slip-induced falls account for 87 percent of all hip fractures which cause functional impairments and admissions to nursing home facilities (Sterling, O'Connor, & Bonadies, 2001). Older individuals recover slowly from hip fractures and are vulnerable to postoperative complications. Moreover, the total cost of fall injuries was \$19.2 billion in 2000 (Stevens, et al., 2006) and is expected to increase to \$54.9 billion by 2020 (CDC, 2010). Reducing the risk of falls in the elderly can help to improve the lives of older adults and control health care cost.

Falls among older adults are a result of complex interactions of various risk factors (Fleming & Pendergast, 1993). There are multiple mechanisms including environment, initiation, detection, and recovery are involved in slip and fall accidents (Lockhart, 2008; Lockhart, et al., 2005; Woollacott, 2000; Woollacott, et al., 1986). The risk factors that predispose older adults to falling can be classified as either intrinsic or extrinsic (Gauchard, Chau, Mur, & Perrin, 2001; Kenny, Rubenstein, Martin, & Tinetti, 2001). Extrinsic factors are represented by adverse drug interactions, prostheses, use of constraints and the environmental factors (Fleming & Pendergast,

1993). Intrinsic factors are identified as degradation of the sensory and motor systems (Cesari et al., 2002; Lockhart, 2008; Lockhart, et al., 2005; Woollacott, 2000; Woollacott, et al., 1986).

## 2.2 Mechanics of Slips and Falls

Four processes associated with slips and falls, shown in Figure 2.1, include environment, initiation, detection, and recovery (i.e., intrinsic or extrinsic factors) (Lockhart, et al., 2005). The mechanics of slips and falls can be separated as before and after a slip-induce fall.

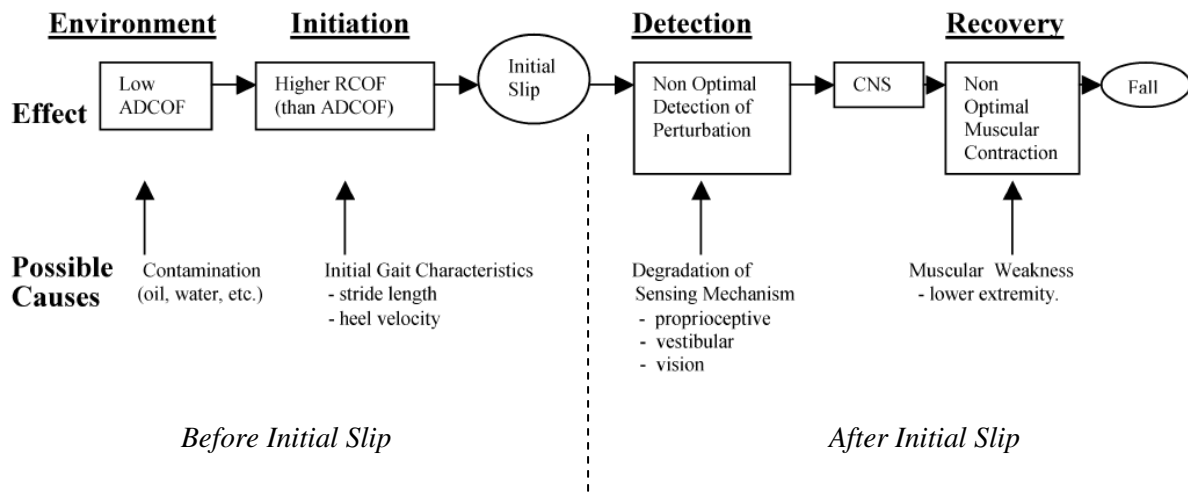

Figure 2.1 The process of initiation, detection, and recovery of inadvertent slips and falls with possible causes and effects (Lockhart, et al., 2005).

### 2.2.1 Before Initial Slip

The mechanics of slips and falls before initial slip are related to environment and initiation processes. In this session, the important knowledge about coefficient of friction and gait characteristics associated to slips and falls is discussed following.

#### 2.2.1.1 Coefficient of Friction

Slipping is defined as “a sudden loss of grip, resulting in sliding of the foot on a surface due to a lower coefficient of friction than that required for the momentary activity, often in the presence of liquid or solid contaminants” (Grönqvist, 1995). The presence of contamination

(e.g., water, oil, etc) on the surface will reduce the dynamic coefficient of friction (DCOF) (Chaffin, Woldstad, & Trujillo, 1992). When the frictional force ( $F_{\mu}$ ) opposing the direction of foot movement is less than the shear force ( $F_h$ ) of the foot immediately after the heel-contact on the floor, slip-induced falls occur (Perkins & Wilson, 1983).

The required coefficient of friction (RCOF) is the minimum COF between the shoe and floor interface to prevent slipping. The RCOF, shown in Figure 2.2, is defined as the ratio of horizontal ground reaction force to vertical ground reaction force,  $F_h/F_v$  ratio (Perkins, 1978). Thus, the combination of lower DCOF and higher RCOF can create slip-induced falls. Perkins (1978) reported dangerous forward slips that lead to falls are most likely to occur 70-120 ms after the heel-contacts the ground.

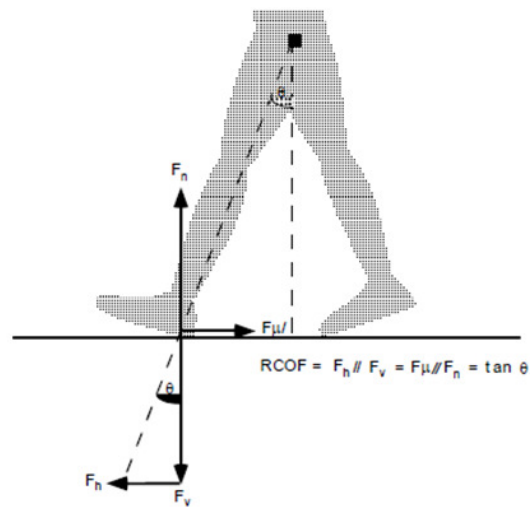

Figure 2.2 The RCOF during the heel-contact phase in normal level walking (Grönqvist, Roine, Järvinen, & Korhonen, 1989).

### 2.2.1.2 Gait Characteristics

There are significant differences in gait between older and younger individuals (Lockhart, et al., 2005). Older individuals tend to have slower walking speed, shorter step length, and less accuracy of foot placement (Menz, Lord, & Fitzpatrick, 2003; Woollacott & Tang, 1997). Therefore, older adults require longer locomotion time because they have a gait cycle with a longer stance or double support time, a period of time between initial contact on the right foot and toe-off of the left foot (Winter, Patla, Frank, & Walt, 1990).

Although gait adjustments in older adults are believed to be beneficial in reducing horizontal foot force to improve gait stability, older adults still undergo slips and falls more than younger adults. It was hypothesized that these gait adjustments may relate to the initiation of slip-induced falls (Lockhart, 2000). However, Lockhart and colleagues (2005) found that the likelihood of slip initiations is similar across all age groups. Thus, slips and falls in older adults may be associated with the mechanics after initial slip (i.e., detection of slips and recovery from falls).

### 2.2.2 After Initial Slip

After initial slip, the mechanics include age-related decline of the nervous system, the sensorimotor integration, and the skeletal muscles (motor systems), as shown in Figure 2.3.

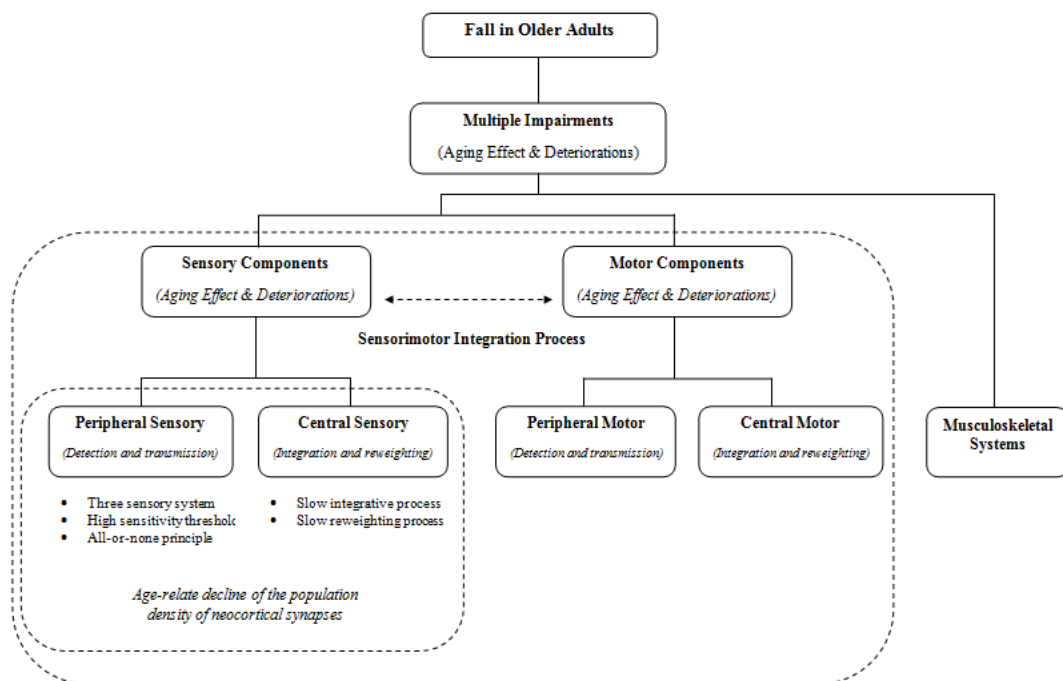

Figure 2.3 The multiple impairments associated with slips and falls in older adults

#### 2.2.2.1 Age-Related Declines of the Nervous Systems

Human balance depends on the interaction of multiple sensory, motor, and integrative systems. These systems decline significantly with advancing age; and these degradations are associated with falling in the elderly. The nervous system has two components, the central

nervous system (CNS) and the peripheral nervous system (PNS). Although both systems are separated anatomically, they are interconnected and interactive (Kandel, Schwartz, & Jessell, 1991). The CNS plays significant roles in integrating the sensory inputs from multisensory neurons from more than one sensory system, and adapting output to a continuously changing internal and external environment (Kandel, et al., 1991). The functions of the CNS and the ability to coordinate complex movements gradually declines with age (Spirduso, 1995). Clearly, age-related slowing in the CNS processing affects integrating goal-related sensory information, selecting a motor program, and executing motor responses.

The function of sensory receptors plays a critical role in providing information from the external environment to create effective movements (Spirduso, 1995). Several researchers have reported that the visual, vestibular, and proprioceptive systems are the sensory systems relevant to motor control and balance maintenance (Lockhart, et al., 2005; Shumway-Cook & Horak, 1986; D. A. Winter, 1995). The accuracy of information from these sensory systems is necessary for the accurate decision making of the CNS regarding any condition (Spirduso, 1995). These sensory systems have redundant and different operating frequency ranges that affect their influence on postural control in different situations (Redfern, Yardley, & Bronstein, 2001).

The performance of these systems are reduced in the elderly; and these systems also degrade at different rates (Kenshalo 1986). Age-related sensory loss is well-documented and is hypothesized by researchers to be the primary reason why older adults lose their orientation sense (Woollacott, 1993; Woollacott, et al., 1986). Thus, decreases in the effectiveness of sensory systems with age could decrease the redundancy of sensory inputs which ensure stability when one or two inputs are lost.

### Vision

The visual system plays a major role in stabilizing posture, guiding locomotion and controlling slip response by providing continually updated information to the CNS (Lee & Lishman, 1975; Lockhart, et al., 2005; Tinetti & Speechley, 1989). Humans utilize optic flow to control their locomotion including steering, accelerating and decelerating walking speed (Warren, Kay, Zosh, Duchon, & Sahuc, 2001). The optical flow is the pattern of apparent motion of objects in a visual scene caused by the relative motion between an observer's eye and the scene (Gibson, 1958; Horn & Schunck, 1981). The flow of optical stimulation affords two types

of information including exteroceptive information (i.e., environmental characteristics) and exproprioceptive information (i.e., movements of the observer) (Gibson & Gibson, 1955; Patla, 1997). Visual information is used in two types of visual control mode including feedforward (e.g., to plan step during approaching the slippery surface) and online (e.g., to immediately change step during avoiding the slippery surface) control modes as shown in Figure 2.4.

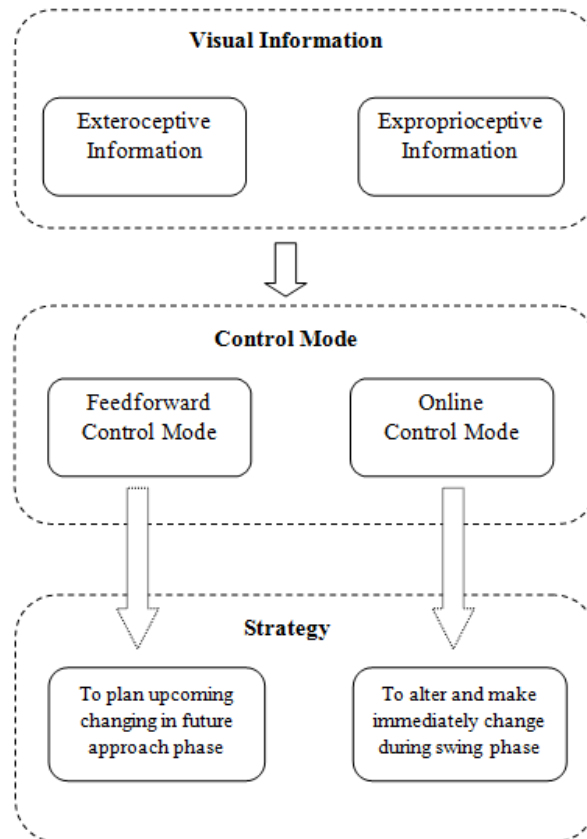

Figure 2.4 Visual information associated with locomotion

Numerous researchers studied the influence of age-related changes on visual input during static stability during standing (Collins & Luca, 1995; Onambélé, Narici, Rejc, & Maganaris, 2007; Pyykko et al., 1988; Teasdale, Stelmach, Breunig, & Meeuwssen, 1991). During static stability, older individuals tend to rely more on visual cues (e.g., the locations of stable surroundings) (Onambélé, et al., 2007; Pyykko, et al., 1988), whereas younger individuals rely more on proprioceptive and vestibular cues (Sheldon, 1963). The elderly may place greater

reliance on the spatial framework provided by vision in an attempt to compensate for reduced vestibular and peripheral sensation (Lord, et al., 2002).

The deterioration in the ability to maintain postural balance with age is claimed to be significantly associated with reduction in tendon stiffness and the absence of visual input (Onambélé, et al., 2007). Visual input may serve to decrease the stiffness of the level of muscular activity across the joints of the lower limb by reducing the gains of proprioceptive and vestibular systems (Collins & Luca, 1995; Collins, Luca, Burrows, & Lipsitz, 1995). Declining visual performance is generally associated with increasing age, and the visual deficits from common eye pathologies such as cataracts, macular degeneration, or glaucoma are also associated with slips and falls in later life. The average of age about 65.8 is a group people who have corrected Visual Acuity 20/40 or better (Ivers et al., 2003).

### Proprioception

Proprioception is the perception of joint and body movements as well as the position of the body, or body segments in space (Sherrington, 1906). Proprioceptive system is claimed to be the quickest and/or the most accurate sensory system that detects changing surfaces (e.g., slippery or uneven surfaces) without visual input (Ghez, 1991). Moreover, the proprioceptive system informs the rate and timing of movement, the amount of force muscles are exerting, and how much and how fast a muscle is being stretched (Ghez, 1991; Hasan & Stuart, 1988). The proprioceptive input also plays a role in motor control by planning and modifying the internally generated motor commands. Disruption of muscle proprioceptive inputs is associated with the increased in postural sway during quiet stance with open eyes. This evidence suggests that proprioceptors must be critical for triggering rapid postural response to a balance perturbation (Diener, Dichgans, Guschlbauer, & Mau, 1984; Mauritz, Dietz, & Haller, 1980).

Studies have indicated a decline in the proprioceptive function in the elderly. The decline of the proprioceptive system correlates with an increased incidence of falls in the elderly (Brocklehurst, Robertson, & James-Groom, 1982). There is a mild increase in the thickness of spindle capsule and diminishes the number of intrafusal fibers per spindle with advancing age (Swash & Fox, 1972). Similarly, the diameter of the muscle spindle also reduces with age (Kararizou, Manta, Kalfakis, & Vassilopoulos, 2005). The declining of proprioceptive is linear with age (Swash & Fox, 1972) however there is no report of specific start declining age of

proprioceptive. These morphological changes may affect static and dynamic muscle spindle sensitivity (Miwa, Miwa, & Kanda, 1995) and decrease the speed and accuracy of movements (Swash & Fox, 1972). The older adults age 72 and older start to show a doubling detection threshold for vibration testing (S. Perry, 2006). Moreover, the acuity of joint position sense in old individuals (age 65+ yrs) shows significant age-related declines than young and middle aged individuals (Hurley, Rees, & Newham, 1998; Skinner, Barrack, & Cook, 1984).

### Vestibular

The vestibular system provides reference information necessary to control postural sway and dynamic balance. Receptors located in the inner ear provide a static vertical reference by comparing the position of the head with respect to gravity. The vestibular system contributes to adjusting activity of the fast postural movements (Inglis, Shupert, Hlavacka, & Horak, 1995; Petersen, Magnusson, Fransson, & Johansson, 1994). This system also responds to sudden weightlessness (e.g., slips and falls) and assists in setting the timing and degree of activity of the motor control system for recovery adjustments (Melvill & Watt, 1971). Additionally, vestibular signals are important for modulating the amplitude of automatic postural response and scaling the magnitude of the postural disturbance (Horak, Nashner, & Diener, 1990).

Several researchers have studied age-related changes in vestibular system (Bergström, 1973; Bruner & Norris, 1971; Mulch & Petermann, 1979; Rosenhall, 1973; Rosenhall & Rubin, 1975). The reduction of sensory cells within the vestibular system is associated with advancing age (Rosenhall, 1973; Rosenhall & Rubin, 1975). This degradation also cause loss of sensitivity in vestibular function in later life (Droller & Pemberton, 1953). Beginning at about 40 years of age, the vestibular neurons decrease in both number and in the size of nerve fibers (Bergström, 1973). Rosenhall (1973, 1975) suggested that there was a moderate but significant reduction of the hair cell population of individual over 70 years of age. Age-related changes of vestibular system bring the potential for the individual to feel insecure in moving around or stopping, particularly under conditions that are less than ideal, such as steep or uneven surfaces. Vestibular loss can create experiences of dizziness as well as excessive sway due to decreased balance in the elderly. Therefore, older adults' degraded vestibular system may reduce their optimum ability



of balance recovery during slip-induced perturbations and increase the risk of slips and falls (Kristinsdottir, Jarnlo, & Magnusson, 2000).

#### 2.3.2.2 Age-Related Declines of the Sensorimotor Integration

Sensorimotor integration is another important mechanism associated with controlling balance. The postural control system during static and dynamic tasks does not utilize each sensory separately, however, it is related to multi-sensory integration (Nashner, 1976; Oie, et al., 2002). Nashner (1976) indicated that the integrative process is not only integrating multi-sensory (visual, vestibular, and proprioceptive) inputs but also dynamically weighting (up-weighting or down-weighting) to maintain while sensory condition changes. Weighting refers to the important process that the central nervous system relies on a particular sensory system in a given situation (Bent, et al., 2005).

Age-related changes in the postural control system are relative to the higher level of the CNS hierarchy that integrates multisensory information. The postural control system is related to the multiple sensory inputs, which are dynamically reweighted to maintain an upright posture while sensory condition changes (Oie, et al., 2002). The CNS has the ability to integrate multisensory information adaptively to solve the ambiguity produced by physical stimuli and to establish a coherent internal perception (Peterka, 2002). During redundancy loss of sensory inputs, the integrative mechanisms will automatically cause sensory reweighting process to adjust toward available inputs (Nashner, 1976).

Studies have shown that older adults are visually dependent during balance maintenances (Pyykko, Jantti, & Aalto, 1990; Sundermier, et al., 1996). Visual dependence is conceived as an over-reliance on visual cues that may be inaccurate or unreliable in the presence of stable and reliable proprioceptive and vestibular cues. Perturbing visual information forces subjects to reorganize the sensory information hierarchy, because vestibular and proprioceptive information become the only sources of sensory information available for the continuous maintenance of balance (Teasdale, et al., 1991). However, multisensory reweighting deficit in older adults causes a failure to switch from inaccurate visual information to accurate proprioceptive and vestibular information, for example, to down-weight vision and up-weight proprioceptive and vestibular

inputs. Moreover, the speed and accuracy of postural adaptation are dependent on the efficiency of the central integrative mechanisms and the sensitivity threshold of sensory systems (Nougier, Bard, Fleury, & Teasdale, 1997; Teasdale & Simoneau, 2001). This reweighting mechanism is time dependent, and it can be delayed or absent when the sensory systems are stressed.

In dynamic tasks such as walking, the relative weighting of these sensory sources may change across lower body responses during locomotion (swing and stance phases) (Bent, Inglis, & McFadyen, 2004). At heel-contact (beginning of double support phase), a moment has been indicated as a critical time for planning of both the current and subsequent steps during locomotion (Hollands & Marple-Horvat, 1996). Visual input is utilized to plan for the next foot placement by the time the foot leaves the ground at toe-off (Hollands & Marple-Horvat, 1996; Hollands, Patla, & Vickers, 2002). Proprioceptive and vestibular inputs need to be integrated to generate an accurate internal representation of the body in space at this particular phase of the gait cycle (Pozzo, Levik, & Berthoz, 1995).

### 2.3.2.3 Age-Related Declines of the Skeletal Muscles

Although the CNS and PNS integrate successfully, the ability to regain balance and recover from slip-induced falls also depends on strength of skeletal muscles. Skeletal muscle comprises 40-50 % of the human body. Aging leads to a decrease in the total skeletal muscle mass. The cross-sectional area of skeletal muscle is reduced by 30-40% by the age of 70. This reduction in muscle mass is one of the main causes of the age-related decrease in muscle strength and power (Porter, Vandervoort, & Lexell, 2007). According to performance and biochemical characteristics of individual muscle cells, muscle fibers have been grouped into two types: type I (slow-twitch) and type II (intermediate or fast-twitch).

The reduction of fast twitch muscle fiber (type II) is greater than the reduction of slow twitch (type I) muscle fibers (Lexell, Taylor, & Sjöström, 1988). Age-related change in muscle function to create fast recovery from falling may be explained by the reduction of the size of type II muscle with age. Especially, leg extensor power appears to decline at an even greater rate with age (Skelton, Greig, Davies, & Young, 1994). Studies have reported that fallers have weaker lower limb muscles than non-fallers; and the lower limb muscle weakness is a major risk

factor for falling in older adults (Lord, Rogers, Howland, & Fitzpatrick, 1999). Thus, the ability to generate stabilizing torques about the hip, knee and ankle joint to recovery from falling declined with age.

## 2.4 Occurrence of Critical Slip Events and Response Time of Sensory Systems

The occurrence of critical slip events and response time of each sensory system is shown in Figure 2.5. The occurrence of critical events between slip-start to slip-stop interval is about 500ms (Lockhart, 2008). The visual processing requires about 150 ms (Schmidt & Lee, 2005; Thorpe, Fize, & Marlot, 1996). However, this short amount of time does not include the required time for response execution to create motor output. Thorpe et al. (1996) reported the median reaction time, including visual processing and response execution time, is about 445 ms (varied between subjects from 382 to 567ms) for study participants aged between 22 to 45 years of age.

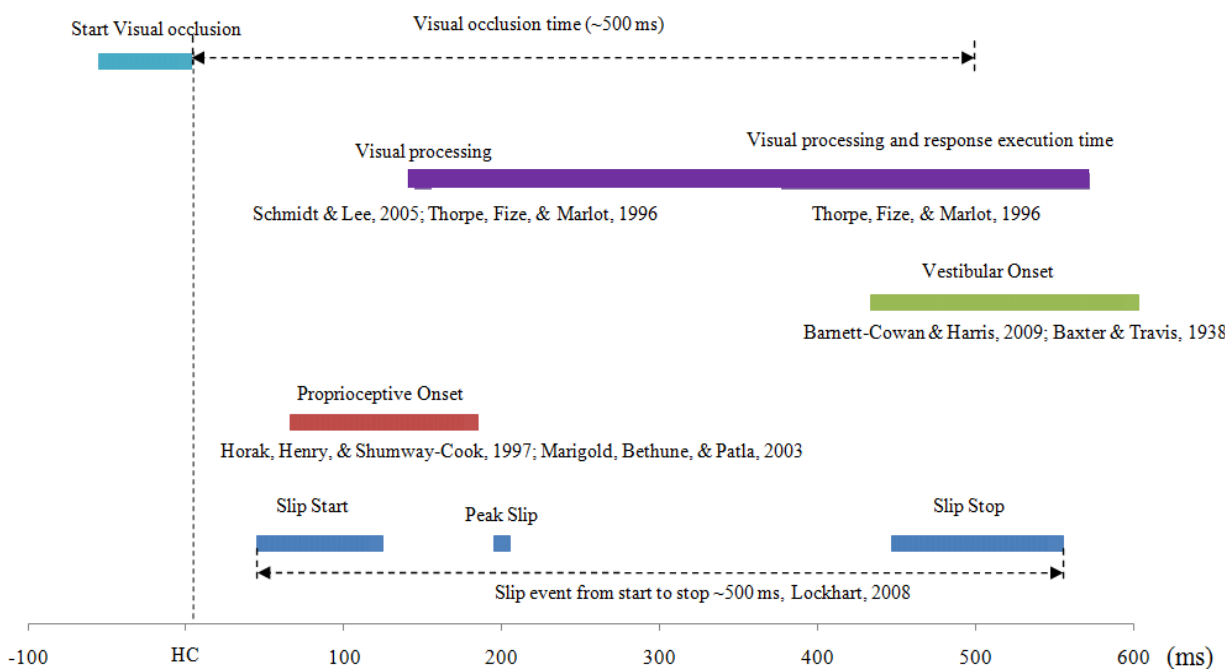

Figure 2.5 Occurrence of critical slip events and response time of visual, proprioceptive, and vestibular systems.

The average vestibular reaction time to passive body motion and head movement is about 438 to 598 ms (Barnett-Cowan & Harris, 2009; Baxter & Travis, 1938). A long-loop stretch reflex, which creates a rapid movement and requires 70-180 ms, may be necessary in avoiding slip-induced falls (Horak, Henry, & Shumway-Cook, 1997; Marigold, Bethune, & Patla, 2003). The time required for visual and response execution processing is approximately the same as the time interval from slip-start to slip-stop. The visual system alone may be too slow to create response execution to avoid slip-induced falls.

At heel-contact (beginning of double support phase), this moment has been indicated as a critical time for planning of both the current and subsequent steps during locomotion (Hollands & Marple-Horvat, 1996). First, visual input is utilized to plan stepping in the last 100 ms of the stance phase of gait (Hollands & Marple-Horvat, 1996; Hollands, et al., 2002). In other words, the program for the next foot placement is complete by the time the foot leaves the ground at toe-off. Second, proprioceptive and vestibular inputs are weighted more heavily during double support than during the swing phase (Bent, et al., 2004). There is an increase in the proprioceptive input because both feet are on the ground. Additionally, the proprioceptive input needs to be integrated with vestibular input to generate an accurate internal representation of the body in space (Pozzo, et al., 1995).

## **2.5 Slip Recovery Processes**

Recovering from a slip-induced fall is a challenging balancing task that requires complex neural and motor control mechanisms. The forward slip starts slightly after heel-contact about 50 – 120 ms (Cham & Redfern, 2001; Perkins, 1978). The time available to achieve adequate frictional forces to avoid a dangerous forward slip is very short after the heel-contact phase of the gait cycle (Lockhart, 2008). In order to avoid a fall after an unexpected slip, the human body must generate a quick response to regain dynamic balance while continuing locomotion.

From a theoretical standpoint, loss of balance is defined as the occurrence of the motion relative to the body center of mass (COM) with respect to the base of support (BOS) exceeds certain stability limits (Pai, 2003). Thus, the ability to restore stability from unexpected slipping is associated with the relationship between the COM and the BOS (Pai & Iqbal, 1999; Pavol,

Owings, Foley, & Grabiner, 2000). The BOS is defined as mean center of pressure (COP) location, measured by a force platform (King, Judge, & Wolfson, 1994). The most hazardous phase for slips is immediately after heel-contact. At the onset of slip-induced falls, if stability cannot be recovered, the fall accidents will occur. Shortly, after heel-contact, the COM moves from behind to ahead of the BOS. Simultaneously, the area of the BOS changes from the heel to flat foot and then the forefoot (C. J. Perry, 1992). Thus, the major goal of recovery from slip-induced falls is to control and bring the COM back within the BOS.

### ***2.5.1 Muscle Activation***

Muscle activation is one of the most important characteristics that provides understanding for automatic postural muscle responses during locomotion and fall recovery. The visual conditions (with and without visual input) cause increased muscle activation in children during treadmill locomotion (Sundermier & Woollacott, 1998). Nashner and Cordo (1981) described that long latency responses activate the shortening (rather than lengthening) of leg muscles in order to maintain the load carried by each leg during surface perturbations. The long-loop reflexes, which are organized at a lower hierarchical level of the CNS, take less time to respond (70-180 ms) (Horak, et al., 1997). The reflexes are triggered by muscle proprioceptive inputs and the complete loop involves the spinal cord, brain stem, and cortical pathway (Al-Zamil, 1998). Muscles of the unperturbed limb are shown to rapidly activate (140– 246 ms) after initiation of an unexpected slip during locomotion (Marigold, et al., 2003). Studies reported these muscle onset latencies during unexpected slip perturbations are suggestive of polysynaptic long-loop reflexes (Marigold, et al., 2003; Marigold & Patla, 2002; Tang, Woollacott, & Chong, 1998).

During slip-induced falls, young and old adults increase the amplitude of muscle activation at medial hamstring and tibialis anterior (Chambers & Cham, 2007). Increase in the amplitude of muscle activation of the lower extremity is an important mechanism to reduce the displacement of the perturbed limb. Due to muscle degradation, onset latencies of postural responses are slower, and burst magnitudes of the responses are smaller in older adults (Tang & Woollacott, 1998). Research has linked slower muscle activation rates as an indicator of increased risk to slip-induced falls. Lockhart & Kim (2006) found a decreased hamstring activation rate in older adults aged +65 and related it to higher risks of slip-induced falls.

Therefore, older adults tend to activate the primary postural muscles for a longer period of time to compensate for muscle degradation.

### ***2.5.2 Muscle Co-Contraction***

Co-contraction of agonist and antagonist muscles is a task independent strategy that is believed to be used to stiffen the joint and enhance stability (Benjuya, Melzer, & Kaplanski, 2004). Studies reported that the co-contraction is modified within the CNS related to task difficulty and abilities of the individual (Carson & Riek, 2001; Enoka, 1997). Co-contraction increases during learning a new motor skill (Falconer & Winter, 1985; Vereijken, van Emmerik, Whiting, & Newell, 1992) and while challenging postural stability tasks (Lamontagne, Richards, & Malouin, 2000).

Regarding static stability, visual input does not show significant contribution to shorter-latency (90-100 ms) automatic postural muscle response during quiet stance with and without vision (Keshner, Woollacott, & Debu, 1988). On the other hand, a study supports that visual input activates slow postural response pathways with latencies of more than 200 ms (Sundermier & Woollacott, 1998). In term of stiffness, several researchers have studied the association between the stiffness of the level of muscular activity across the joints and visual input. Studies reported that joint stiffness is reduced while visual input is available, and visual input may serve to reduce the gains of proprioceptive and vestibular systems (Collins & Luca, 1995; Collins, et al., 1995; Onambélé, et al., 2007).

The muscle activity and the co-ordination between the two lower extremities were found to be the keys to reactive recovery balance control (Tang, et al., 1998). On the other hand, excessive co-contraction or stiffness may cause extreme instability and impair movement (Horak, Nutt, & Nashner, 1992). Increasing compressive loading of the joints may result in reducing flexibility and adaptability during slip perturbations. Task-specific training has been suggested in a reduction in levels of co-contraction (Macaluso & Vito, 2004).

Age related muscle declines are also associated with higher levels of co-contraction (Ferri et al., 2003; Psek & Cafarelli, 1993). Chambers & Cham (2007) reported ankle and knee muscle co-contraction increased with expected slip perturbations in both age groups (younger and older adults). Longer agonist/antagonist co-contraction of muscles around the leg joints was found in older adults (Tang & Woollacott, 1998). Increasing ankle muscle co-contraction may result in

controlling foot position and avoiding slip-induced falls (Hof, Elzinga, Grimmius, & Halbertsma, 2005). However, an increase in knee muscle co-contraction is still unclear in fall recovery. Therefore, the study investigating the association between visual input and joint stiffness during slip-induced falls is warranted.

In summary, falls are a leading cause of injury and death in older adults. The age-related sensory degradation may influence the likelihood of slips and falls. Age-related decline in sensory processing influences multi-sensory weighting in older adults. Among three sensory systems, vision is known as an important sensory system for balance maintenances, especially in older adults who have visual dependent behavior. Although, numerous studies have reported the influence of visual input on static postural stability, loss of balance during quiet stance is barely representative of loss of balance in real world situations as such, a more realistic dynamic fall testing paradigm is needed.

In everyday life, several situations can influence temporary vision loss during locomotion (e.g., multifocal glasses, carrying loads, etc), and the inaccurate visual input during dynamic tasks may increase the risk of slips and falls. However, the effect of visual input associated with locomotion and unexpected slip perturbations (i.e., dynamic tasks) remains unclear. The time required for visual and response execution processing is approximately the same as the time interval from slip-start to slip-stop (approximately 500 ms). Therefore, the visual system alone may be too slow to execute a response to avoid slip-induced falls. The purpose of this study is to investigate the age-related effects of visual input on multi-sensory process during locomotion and unexpected slip perturbations.

## CHAPTER 3

### **STUDY I– The Age-Related Effects of Visual Input on Automatic Postural Muscle Response During Human Locomotion.**

#### **3.1 Objective**

The objective of this study is to determine the effects of age on gait characteristics, postural control and muscle activation patterns associated with a visual perturbation at the heel-contact during normal walking. Two visual conditions include: 1) continuous visual input and 2) unexpected visual perturbation (i.e., temporary loss of visual input) at the heel-contact (HC) phase of the gait cycle.

#### **3.2 Participants**

##### *3.2.1 Sample Size Estimates*

The sample size was estimated by using power analysis. To estimate sample size, a power analysis was performed on results of the pilot study by focusing on sample sizes that were large enough to determine differences between the co-contraction index (CCI) during normal walking with visual input and unexpected loss of visual input. The general test statistic for two populations was the standard two-sided t test, for which the power of the test (Neter, 1996) is given by:

$$\text{Power} = P \{ |t^*| > t(1 - \alpha/2; n-2 \mid \delta) \}$$

$$\delta = |A - B| / \sigma\sqrt{(2/n)}$$

where:

$\delta$  is the noncentrality parameter, or a measure of the difference between the means of A and B (co-contraction index, CCI)

$\sigma$  is the standard deviation of the distribution of CCI and  $n$  is the number of participants



Therefore, means and standard deviations of CCI in the pilot study were used to compute the required sample size respectively. Table 3.1 summarizes the required sample size for detecting significant differences in knee CCI and ankle CCI, given  $\alpha = 0.05$  and  $\beta = 0.20$ . The final sample size was determined as  $n = 15$ , using the maximum number of sample size from ankle CCI.

Table 3.1 The required sample size for detecting significant differences between walking with visual input and without visual input, given  $\alpha = 0.05$  and  $\beta = 0.20$ .

	Knee CCI	Ankle CCI
$\delta$	0.60	0.40
$\sigma$	0.47	0.37
n	11	15

### 3.2.2 Screening Test

Participants were recruited from flyers placed around the Virginia Tech campus and the community (Blacksburg, VA). Fifteen young adults (age between 18-30 year old) and fifteen older adults (age 65 -84 year old) were recruited to participant in this study. The mean and standard deviation of participants' age, weight and height are shown in Table 3.2. Each age group consisted of equal number of male and female (7 males and 8 females per group). The oldest age was 84 year old because the rate of falls increased exponentially with age for both elderly men and women, reaching a high for those aged 85+ years ("National Council on Ageing," 2005; Sattin et al., 1990).

Table 3.2 Mean and S.D. of participants' age, weight and height

Age Group	Gender	Age	Weight	Height
Young	Male	21.00 $\pm$ 2.08	160.00 $\pm$ 29.58	179.19 $\pm$ 6.09
	Female	23.50 $\pm$ 3.46	132.13 $\pm$ 35.04	164.34 $\pm$ 6.51
Old	Male	73.29 $\pm$ 4.68	190.29 $\pm$ 27.38	173.31 $\pm$ 6.07
	Female	74.88 $\pm$ 5.72	145.56 $\pm$ 42.33	159.29 $\pm$ 7.50

The recruited participants reported to be in generally good health, with no cardiovascular, respiratory, neurological, and musculoskeletal abnormalities. Participants were tested for ankle, knee, and hip range of motion and any balance related problems such as Romberg, light touch test to exclude individuals with any kind of neurological, musculoskeletal or balance problems (Bohannon, Larkin, Cook, Gear, & Singer, 1984).

All participants performed static visual acuity and color vision test, using the Bausch & Lomb Vision Tester, shown in Figure 3.1, to ensure that participants have normal vision. Visual acuity impairment was defined according to the trichotomy of "normal vision" (20/40 or better) commonly used in the American medical-legal system (Rubin et al., 1997). Therefore, 20/40 was required for visual acuity test of both eyes of interested participants in both age groups (Hunter & Hoffman, 2001).



Figure 3.1 The Bausch & Lomb Vision Tester

### 3.3 Apparatus

The experiment was conducted on a 15-meter linear walking track, embedded with two force plates (BERTEC #K80102, Type 45550-08, Bertec Corporation, OH 43212, USA). A six-camera ProReflex system (Qualysis) was used to collect three-dimensional posture data of participants as they walked over the test floor surface. Kinematic data were sampled and recorded at 120 Hz. Ground reaction forces of participants walking over the test surfaces was measured using two force plates and sampled at a rate of 1200 Hz. The experimental set up is showed in Figure 3.2. An eight-channel EMG telemetry Myosystem 900 (Noraxon, USA), was used to record the temporal activations of four muscle groups in the both lower extremity during

normal walking. The EMG system is composed of one transmitter, one receiver and surface electrodes. The transmitter is portable and powered by a battery (9 V), and the receiver telecommunicates to the transmitter. Raw EMG signals were monitored, sampled and stored by the National Instrument hardware and the LabVIEW system with sampling rate of 1200 Hz.

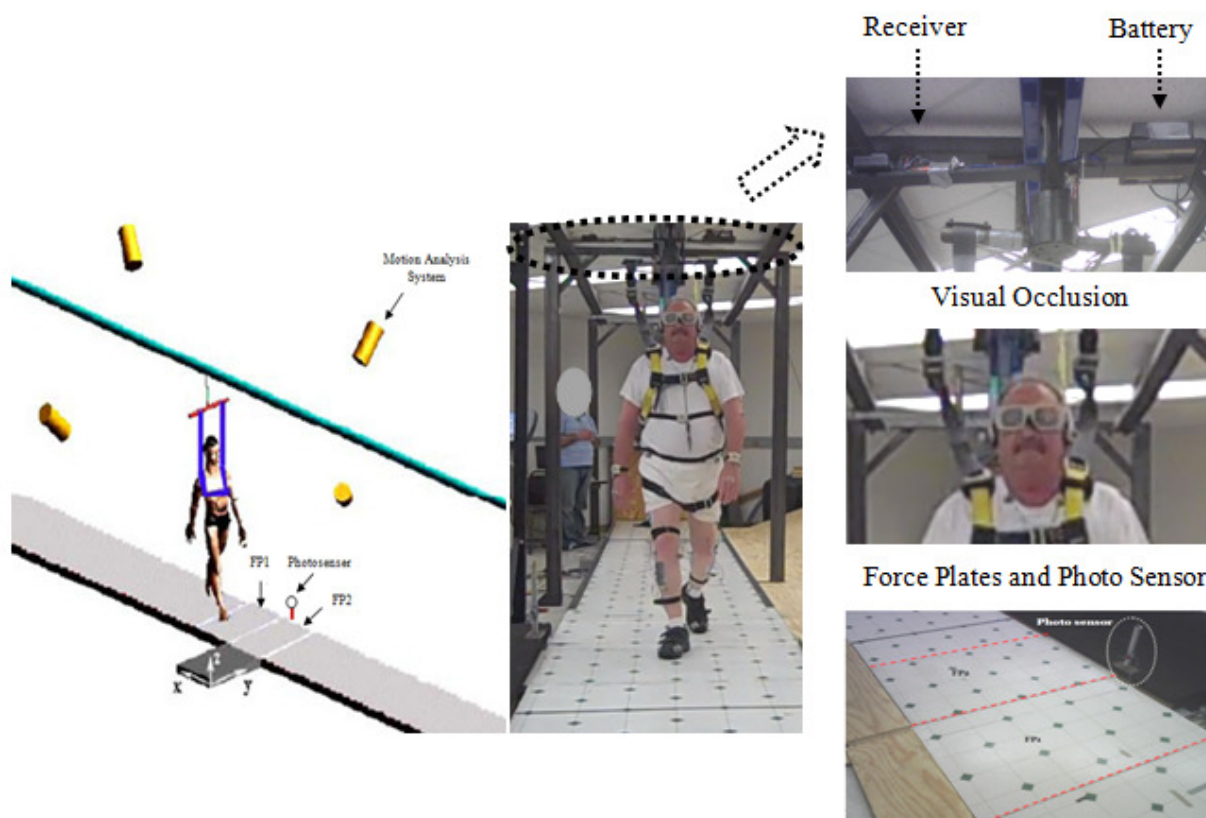

Figure 3.2 Experimental set up including two force plates, motion capture system, and glasses controller set

Additionally, portable liquid crystal display glasses (PLATO: Portable Liquid-crystal Apparatus for Tachistoscopic Occlusion) were used to introduce the visual occlusion. A glasses controller set, shown in Figure 3.3, includes a photoelectric reflective sensor, timer relay (Timer), two relays (R1 and R2), and power supply.

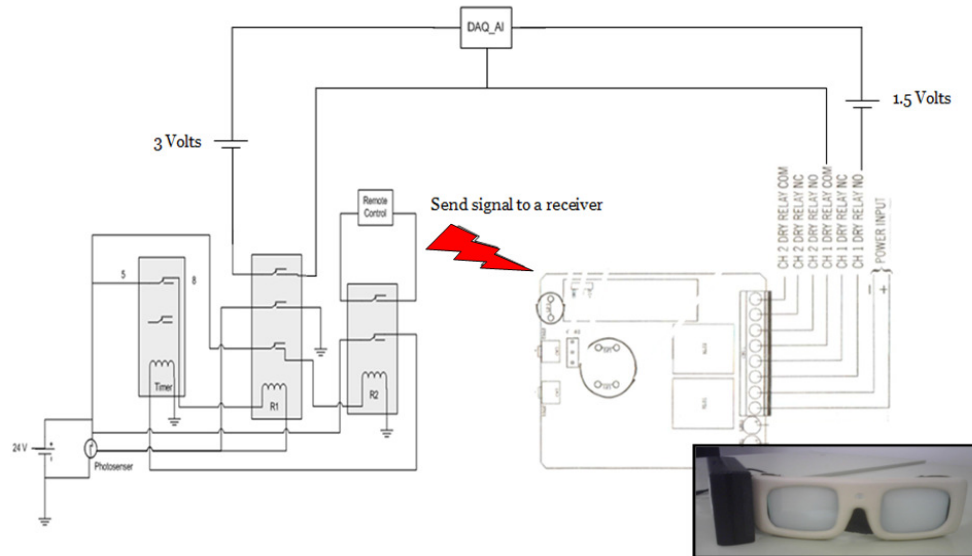

Figure 3.3 The glasses controller set and PLATO: Portable Liquid-crystal Apparatus for Tachistoscopic Occlusion

The photo sensor was used to detect the right heel before contacting to the walking surface (force plate 2) as shown in Figure 3.4 and sent a signal to the glasses controller.

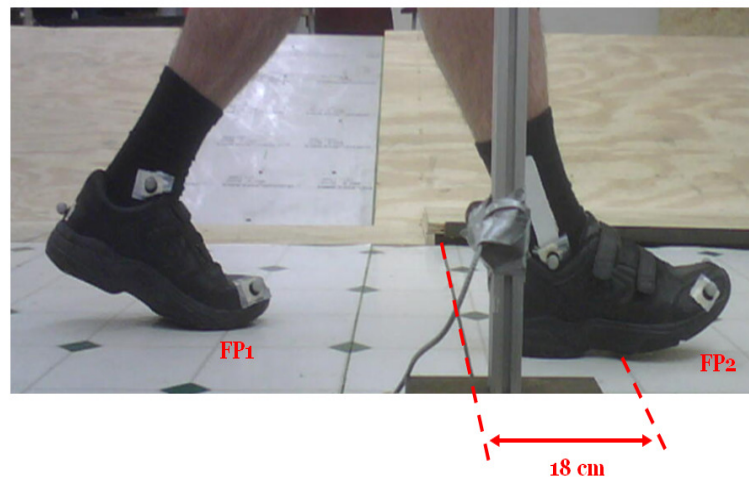

Figure 3.4 The trigger detects right lower limb swing before heel-contact event

The controller set sent the signal to a wireless receiver and sent 3 volts to the National Instrument hardware to detect the initiated occlusion time. A signal from the glasses controller was sent to the wireless receiver to change the status of the glasses from transparent to opaque to occlude visual input for approximately a half of second ( $573 \pm 2.15$  ms), as shown in Figure 3.5.

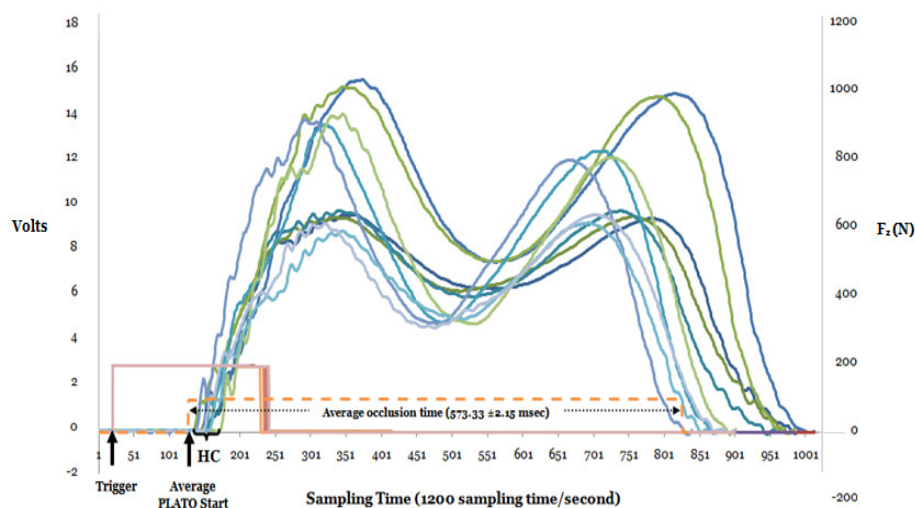

Figure 3.5 Example of the association of signal profile from the controller set (volts) and vertical force profile during heel-contact event

A LabView program was designed to synchronize the data collection from the motion analysis system, force plates, and glasses controller. To verify the effect of wearing PLATO, the gait parameters during walking with and without PLATO were analyzed and shown in Table 3.3. The results suggested that both conditions did not have statistically significant different on gait parameters. Thus, wearing PLATO does not influence gait characteristics.

Table 3.3 Mean and S.D. of gait parameters during walking with and without PLATO

Gait Parameters	Walking without PLATO	Walking with PLATO	P-Value
Step length (cm)	73.00 (4.90)	74.10(3.10)	0.7674
Step width (cm)	12.10 (2.60)	12.20(2.60)	0.9582
Walking velocity (m/s)	1.390(0.064)	1.416(0.042)	0.5943
Double Support Time (s)	0.128 (0.009)	0.134(0.017)	0.5687
RCOF	0.196(0.003)	0.208(0.012)	0.1367

### 3.4 Protocol Study I

Participants were asked to wear the liquid crystal display glasses (PLATO) and outfit of laboratory clothing and shoes. The PLATO provides complete occlusion of both central and peripheral vision when the PLATO is activated ("closed", opaque). Twenty-six markers were attached to anatomical landmarks of the lower extremities, trunk, arms, and head (head, ears, acromioclavicular joint, acromion, lateral humeral condyle, ulnar styloid, head of the third metacarpal, anterior superior iliac spine (ASIS), lateral femoral condyle, calcaneus, malleolus, and base of the second metatarsal). The marker configuration was adopted from previous studies including the most recent publications (Liu & Lockhart, 2006; Lockhart, et al., 2005). Bipolar Ag-AgCl surface electrodes were placed over Vastus Lateralis (VL), Medial Hamstring (MH), Tibialis Anterior (TA) and Medial Gastrocnemius (MG) muscles of the lower extremity (Chambers & Cham, 2007; Parijat, 2009). Another reflective marker was attached above the right ankle. Figure 3.6 shows an example of participant with completed markers, EMG electrodes, and PLATO



Figure 3.6 A participant with completed markers, EMG electrodes, and PLATO

A photoelectric reflective sensor was used to detect the swing phase before the right heel-contact. A signal from the glasses controller was sent to the wireless receiver to change the status of the glasses from transparent to opaque to occlude visual input. When the PLATO was

deactivated (“open”, transparent), near-complete field-of-view was provided. During the experiment, participants were asked to wear an overhead safety harness at all time to protect them from potential injury. Each participant experienced two visual input conditions (within subject, visual input factor) during normal walking. Participants were instructed to look straight ahead and walk naturally at a self-selected pace. Next, participants were asked to practice walking as the experimenters varied the starting point to ensure proper foot contact. Five normal walking trials were conducted as normal walking with visual input (NWV) trials. Another gait trial was conducted as normal walking with unexpected loss of visual input (without visual input, NWOV). Visual input was occluded during normal walking without the participant’s prior knowledge.

### **3.5 Data Analyses**

The coordinate force plates and markers data were filtered by low-pass filter using fourth order, zero lag, Butterworth filter at a cut of frequency of 6 Hz (Liu & Lockhart, 2006). The EMG data were collected at 1200 Hz using a Noraxon Telemetry 8-channel electromyography system with a hardware band pass filter, 10–500 Hz (Chambers & Cham, 2007). The band pass filtered data were rectified and low-pass filtered using a fourth order, zero lag, Butterworth filter with a 10 Hz cut-off frequency to create a linear envelope (Marigold, et al., 2003). Heel-contact (HC) and Toe-off (TO) of the right limb were identified from the ground reaction forces. The analyses were performed during the stance phase from HC to TO as in previous studies (Chambers & Cham, 2007; Marigold, et al., 2003; Parijat, 2009).

### **3.6 Experimental Design**

The experimental design matrix is shown in Table 3.4. Two independent variables include age groups (i.e., young and old individuals) and visual input conditions (i.e., with and without visual input).

Table 3.4 The experimental design matrix for study I

	Walking with visual input (NWV)	Walking without visual input (NWOV)
Young Individuals	P1-P15	P1-P15
Old Individuals	P16-P30	P16-P30

### 3.6.1 Independent Variables

Based on the study I experiment design as shown in Table 3.2, a mixed-factor multivariate analysis of variance (MANOVA) was conducted where age was a between-subjects factor and visual conditions was within-subject factors. Using the Wilks' Lambda test, the MANOVA allowed for determination of which factors and relevant interactions had significant effects on the multiple dependent variables as a whole (i.e., gait parameters, kinematic angular, muscle co-contraction). Since a global effect did not contain information about how each of the dependent variables was affected, a statistically significant main effect or interaction effect found in the MANOVA test triggered subsequent univariate analysis of variance (ANOVA) to elucidate the effect on each of the dependent variables. Thus, following the MANOVA test, subsequent univariate ANOVAs (mixed factor design) were conducted separately for each dependent variable. The statistical model of a two-way mixed-factor ANOVA is shown below:

ANOVA table is provided in Table 3.5. The structural model for *the mixed factor ANOVA design* is given below (A-between subjects and B-within subject):

$$Y_{ijkl} = \mu + \alpha_i + \beta_j + \gamma_{k(i)} + \alpha\beta_{ij} + \beta\gamma_{jk(i)} + \varepsilon_{l(ijk)}$$

where:

$Y$  is observation

$\mu$  is population mean

A is a between-subjects variable (age group:  $i = 2$ )

B is a within-subject variable (visual input:  $j = 2$ )

S is the number of the subject in each group ( $k = 15$ ) and

$\varepsilon$  is random error.



Table 3.5 Source and Error terms for mixed-factor ANOVA

Source	df	SS	MS	E{MS}	F
<u>Between</u>					
A	a-1	SSA	MSA	$bn\sigma_{\alpha}^2 + b\sigma_{\gamma}^2 + \sigma_{\epsilon}^2$	MSA/ MSS(A)
S(A)	a(n-1)	SSS(A)	MSS(A)	$b\sigma_{\gamma}^2 + \sigma_{\epsilon}^2$	
<u>Within</u>					
B	b-1	SSB	MSB	$an\sigma_{\beta}^2 + \sigma_{\beta\gamma}^2 + \sigma_{\epsilon}^2$	MSB/ MSBS(A)
BxA	(a-1)(b-1)	SSBA	MSBA	$n\sigma_{\alpha\beta}^2 + \sigma_{\beta\gamma}^2 + \sigma_{\epsilon}^2$	MSBA/ MSBS(A)
BxS(A)	a(b-1)(n-1)	SSBS(A)	MSBS(A)	$\sigma_{\beta\gamma}^2 + \sigma_{\epsilon}^2$	
<u>Total</u>	abn-1	SS <sub>Total</sub>			

### 3.6.2 Dependent Variables

In this study, normal walking with continuous visual input and unexpected visual perturbation at the heel-contact were constrained respectively. Data from walking without visual input (NWOV) trial were time normalized using the stance duration of the walking with visual input (NWV) trial. The time normalized was computed with respect to the stance leg with 0% being HC and 100% as TO.

#### 3.6.2.1 Friction Demand

The presence of contamination (e.g., water, oil, etc) on the surface reduces the dynamic coefficient of friction (DCOF) (Chaffin, et al., 1992). The required coefficient of friction (RCOF) is the minimum required coefficient of friction between the shoe and floor interface to prevent slipping. The RCOF is defined as the ratio of horizontal ground reaction force to vertical ground reaction force,  $F_h/F_v$  ratio (Perkins, 1978). When the frictional force ( $F_{\mu}$ ) opposing the direction of foot movement is less than the shear force ( $F_h$ ) of the foot immediately after the heel-contact on the floor, slip-induced falls occur (Perkins & Wilson, 1983). If the actual friction demand (as quantified by the RCOF) is greater than the DCOF of a certain shoe-floor interface, a slip is likely to occur.

### 3.6.2.2 Gait Parameters

All gait parameters were measured from two steps including first step and the next step (i.e., subsequent step). Figure 3.7 shows the first step and the next step related to the location of force plates and a glasses trigger.

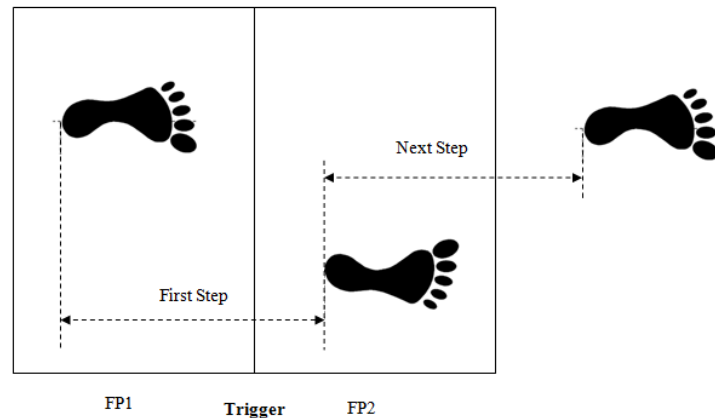

Figure 3.7 Gait associated with the first step and next step after visual occlusion

Walking Velocity (WV): Walking velocity is the distance covered by the whole body in a given time (Whittle, 2002). Walking speed was calculated by the following equation:

$$\text{Walking velocity (m/s)} = \text{Distance of one walking cycle (m)} / \text{cycle time (s)}$$

Step Length (SL): Step length, shown in Figure 3.8, is the distance travelled by a person during one step and can be measured as the length between the right heel and left heel.

Step Width (SW): Step Width is the mediolateral distance between feet, shown in Figure 3.8 (Vaughan, Davis, & Jeremy, 1992).

Step Duration (SD): Step duration time, shown in Figure 3.9, is a period of time between initial contact on the right foot and initial contact on the left foot.

Double Support Time (DST): Double support time, shown in Figure 3.9, is a period of time between initial contact on the right foot and toe-off of the left foot.

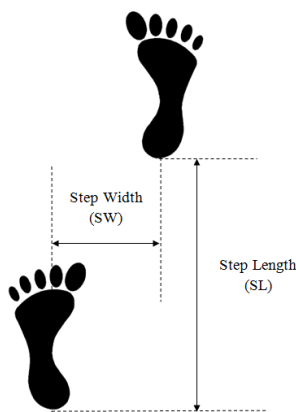

Figure 3.8 A person's footprints associated with Step width (SW) and Step length (SL)

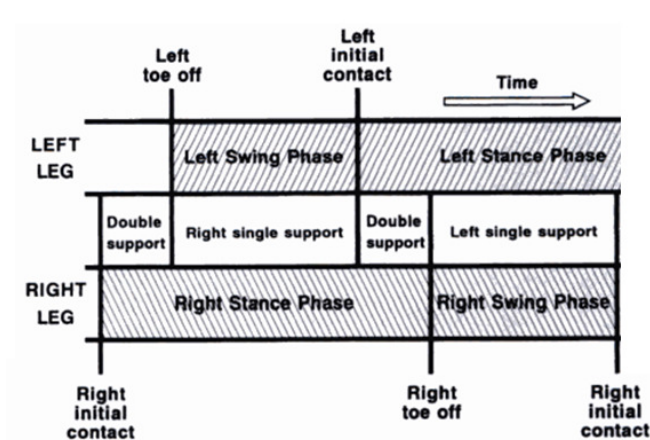

Figure 3.9 Timing of single and double support during one gait cycle (Whittle, 2002)

### 3.6.2.3 Postural Adjustments

Joint angles (hip, knee, and ankle joint angle) of the right limb were calculated to determine the influence of visual perturbation on angular kinematics. Figure 3.10 shows the posture model with the joint angles on the sagittal plane. Trunk flexion angle is the angle between trunk and vertical. Hip flexion angle is the angle between pelvis and thigh. Knee flexion angle is the angle between the thigh and shank segments of the leg. The ankle dorsiflexion angle is defined by the angles of the shank and foot segments. The lower extremity 2D joint angles (trunk, hip, knee, and ankle) were calculated using methods described previously (Lockhart & Liu, 2006; Parijat, 2009). Heel-contact (HC) and Toe-off (TO) of the right limb were identified

from the ground reaction forces. The analyses were performed during the stance phase from HC to TO as previous studies (Chambers & Cham, 2007; Marigold, et al., 2003; Parijat, 2009).

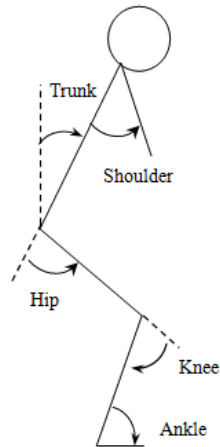

Figure 3.10 The posture model describes the position of the body segments with the following angles on the sagittal plane: shoulder flexion angle, trunk flexion angle, hip flexion angle, knee flexion angle, and ankle dorsiflexion angle.

Shoulder flexion angle: Shoulder flexion angle is the angle between the trunk (acromion and anterior superior iliac spine (ASIS)) and upper arm segments. The sagittal shoulder flexion angle,  $\theta_{shoulder}$ , was computed by the following equation:

$$\theta_{shoulder} = \theta_{trunk} - \theta_{upper\ arm}$$

The sagittal angle of trunk (acromion and anterior superior iliac spine (ASIS)) segment,  $\theta_{trunk}$ , was analyzed by calculating the inverse tangent of the difference between the anterior superior iliac spine (ASIS) and acromion markers. The sagittal angle of the upper arm segment,  $\theta_{upper\ arm}$ , was analyzed by calculating the inverse tangent of the difference between the acromion and lateral humeral condyle markers.  $\theta_{trunk}$  and  $\theta_{upper\ arm}$  was computed by the following equations:

$$\theta_{trunk} = \text{atan} \left( \frac{Z_{acromion} - Z_{ASIS}}{X_{acromion} - X_{ASIS}} \right)$$

$$\theta_{thigh} = \text{atan} \left( \frac{Z_{acromion} - Z_{lateral\ humeral\ condyle}}{X_{acromion} - X_{lateral\ humeral\ condyle}} \right)$$

Trunk flexion angle: Trunk flexion angle is the angle between the trunk and the vertical axis. The sagittal trunk flexion angle,  $\theta_{trunk}$ , was calculated by the inverse tangent of the difference between the middle of both anterior superior iliac spines (ASISs) and middle of both acromioclavicular joints.

$$\theta_{trunk} = - \text{atan} \left( \frac{Z_{mid\_clav} - Z_{mid\_ASIS}}{X_{mid\_clav} - X_{mid\_ASIS}} \right) + 90^\circ$$

Hip flexion angle: Hip flexion angle is the angle between the HAT (hand, arm, and trunk) and thigh segments. The sagittal hip flexion angle,  $\theta_{hip}$ , was computed by the following equation:

$$\theta_{hip} = \theta_{HAT} - \theta_{thigh}$$

The sagittal angle of HAT segment,  $\theta_{HAT}$ , was analyzed by calculating the inverse tangent of the difference between the anterior superior iliac spine (ASIS) and acromion midpoint markers. The sagittal angle of the thigh segment,  $\theta_{thigh}$ , was analyzed by calculating the inverse tangent of the difference between the anterior superior iliac spine (ASIS) and condyle markers.  $\theta_{HAT}$  and  $\theta_{thigh}$  was computed by the following equations:

$$\theta_{HAT} = \text{atan} \left( \frac{Z_{acro} - Z_{ASIS}}{X_{acro} - X_{ASIS}} \right)$$

$$\theta_{thigh} = \text{atan} \left( \frac{Z_{ASIS} - Z_{condyle}}{X_{ASIS} - X_{condyle}} \right)$$

Knee flexion angle: Knee flexion angle is the angle between the thigh and shank segments of the leg. The sagittal knee flexion angle,  $\theta_{knee}$ , was computed by the following equation:

$$\theta_{knee} = \theta_{thigh} - \theta_{shank}$$

The sagittal angle of the shank segment,  $\theta_{shank}$ , was analyzed by calculating the inverse tangent of the difference between the condyle and lateral malleolus markers as shown in the following equation:

$$\theta_{shank} = \text{atan} \left( \frac{Z_{\text{condyle}} - Z_{\text{lateral malleolus}}}{X_{\text{condyle}} - X_{\text{lateral malleolus}}} \right)$$

Ankle dorsiflexion angle: Ankle dorsiflexion angle is the angle between the shank and foot segments angles minus an additional 90 degrees to correct for the natural orientation of the foot with respect to the shank. The sagittal ankle dorsiflexion flexion angle,  $\theta_{ankle}$ , was computed by the following equation:

$$\theta_{ankle} = \theta_{foot} - \theta_{shank} - 90^\circ$$

The sagittal angle of the foot segment,  $\theta_{foot}$ , was analyzed by calculating the inverse tangent of the difference between the heel and toe markers, shown in the following equation:

$$\theta_{foot} = \text{atan} \left( \frac{Z_{\text{toe}} - Z_{\text{heel}}}{X_{\text{toe}} - X_{\text{heel}}} \right)$$

#### 3.6.2.4 Muscle Co-Contraction

EMG data were normalized within subject with respect to the average maximum calculated across the normal walking with continuous visual input condition during gait cycle by creating the normal ensemble average profile (Chambers & Cham, 2007). A three-step process was applied to create the ensemble average profile for a number of strides (Frigo & Shiavi, 2004). First, scanning the time of heel-contact (HC) to toe-off (TO) because of the stride

duration varies from stride to stride. Heel-contact was determined from the vertical ground reaction force traces using a 10 N threshold. The second step was normalizing the time scales of each linear envelop to at least 256 points which is a sufficient number. Finally, averaging all of linear envelop together in an ensemble manner. This normalized method was performed to reduce the variability in muscle activity due to variations in electrode position and electrode excitation voltage and possible fluctuations between trials (Kadaba et al., 1989; Yang & Winter, 1984).

Then, co-contraction index (CCI) was calculated by the following equation (Rudolph, Axe, Buchanan, Scholz, & Snyder-Mackler, 2001):

$$CCI = \frac{LowerEMG_i}{HigherEMG_i} \times (LowerEMG_i + HigherEMG_i)$$

where  $LowerEMG_i$  refers to the less active muscle at time  $i$

$HigherEMG_i$  refers to the more active muscle at time  $i$

Gait cycle events in this analysis including heel-contact (HC), midstance (MS), and toe-off (TO) were determined via force plate activation (10N force) and motion analysis system accordingly within the data to identify gait cycles. CCI was analyzed based on the ratio of the EMG activity of the antagonist/agonist muscle pairs of TA/MG and VL/MH by calculating based on the integrated ratio of the EMG activity (from -20% to 20% into stance, with HC being 0%; from 30% to 70% into stance, with MS being 50%; from 80% to 120% into stance, with TO being 100%) (Chambers & Cham, 2007; Garner, Wade, MacDonald, & Lamont, 2011).  $LowerEMG_i$  is the level of activity in the less active muscle and  $HigherEMG_i$  is the level of activity in the more active muscle to avoid division by zero errors. Integrated CCI was calculated by integrating area under CCI curve from previous equation. This method does not identify which muscle is more active; rather it provides an estimate of relative activation of the pairs of muscles as well as the magnitude of co-contraction (Rudolph, et al., 2001).

### 3.7 Statistical Analyses

To determine the effect of age (young vs. old) and visual input during normal walking (NWV vs. NWOV) on several dependent variables were measured and calculated in terms of gait parameters, kinematic adjustments, and muscle activity. A mixed-factor multivariate analysis of variance (MANOVA) was conducted where age was a between-subjects factor and visual conditions were within-subject factors. Using the Wilks' Lambda test, the MANOVA allowed for determination of which factors and relevant interactions had significant effects on each group of dependent variables. The purpose of conducting a MANOVA was to have a global assessment of the effects of the independent variables on all dependent variables as a whole.

If a statistically significant main effect of age and/or visual conditions were found, univariate analysis of variance (ANOVA) was conducted to elucidate the effect of main effect on the dependent measures. Post-hoc comparisons were performed to identify differences in the effects of different levels of the independent variables. To determine if both age groups had similar gait characteristics during both walking trials, a one-way ANOVA was conducted on gait measures (step length, walking velocity and RCOF at heel-contact). All statistical analyses were conducted using JMP 9.0 (SAS Institute, Cary, NC, USA). In order to verify the assumptions of MANOVA and ANOVA, all of the data were evaluated for normality (using Shapiro-Wilk W test), homogeneity of variance (using Hartley F-Max Test), and sphericity (using Bartlett's sphericity test). Logarithmic transformation was used to transform data which were not normally distributed. Non-parametric statistics was used with the values obtained were not normally distributed after logarithmic transformation (Altman, 1991).

### 3.8 Results

#### *3.8.1 Required Coefficient of Friction (RCOF) and walking velocity*

A one-way ANOVA was conducted on walking velocity and RCOF between NWV and NWOV trials to ensure that participants had similar gait characteristics during the experimental session. ANOVA results showed no significant difference of walking velocity and RCOF between NWV and NWOV trials. The mean and standard deviation gait parameters during NWV and NWOV trials between young and old groups are shown in Table 3.6.



Table 3.6 Mean  $\pm$  S.D. of gait parameters during NWV and NWOV trials between young and old groups

Dependent Variables	Young	Old
RCOF during NWV trial	0.20 $\pm$ 0.24	0.16 $\pm$ 0.02
RCOF during NWOV trial	0.20 $\pm$ 0.03	0.18 $\pm$ 0.03
Walking velocity during NWV trial (m/s)	1.44 $\pm$ 0.15	1.23 $\pm$ 0.14
Walking velocity during NWOV trial (m/s)	1.44 $\pm$ 0.17	1.26 $\pm$ 0.13

### 3.8.2 Gait Parameters

A mixed-factor MANOVA was conducted between age groups (between-subjects) and visual conditions (within-subject) with the gait parameters (first step length (FSL), first step width (FSW), first step duration (FSD), first double support time (FDST), next step length (NSL), next step width (NSW), next step duration (NSD), and next double support time (NDST)). Logarithmic transformation was used to transform FSL data which were not normally distributed before conducting MANOVA test. The MANOVA indicated that gait parameters was significantly affected by age groups ( $F_{(8,49)} = 14.1172$ ,  $P < 0.0001^*$ ) with Wilks' Lambda ( $P < 0.0001^*$ ).

As such, subsequent univariate ANOVAs were conducted to provide better understanding of how gait parameters were influenced by age groups and visual conditions on each dependent variable. For the first step, older adults had a significantly shorter step length ( $F_{(1,56)} = 50.4512$ ,  $P < 0.0001^*$ ), narrower step width ( $F_{(1,56)} = 50.4512$ ,  $P < 0.0001^*$ ), and longer double support time ( $F_{(1,56)} = 19.3103$ ,  $P < 0.0001^*$ ) than their younger counterparts, as shown in Figure 3.11. The results also showed that older adults had longer step durations compared to the younger adults, but no significant difference between age groups was identified. There was no significant difference of the first step gait characteristics between NWV and NWOV, as shown in Figure 3.12.

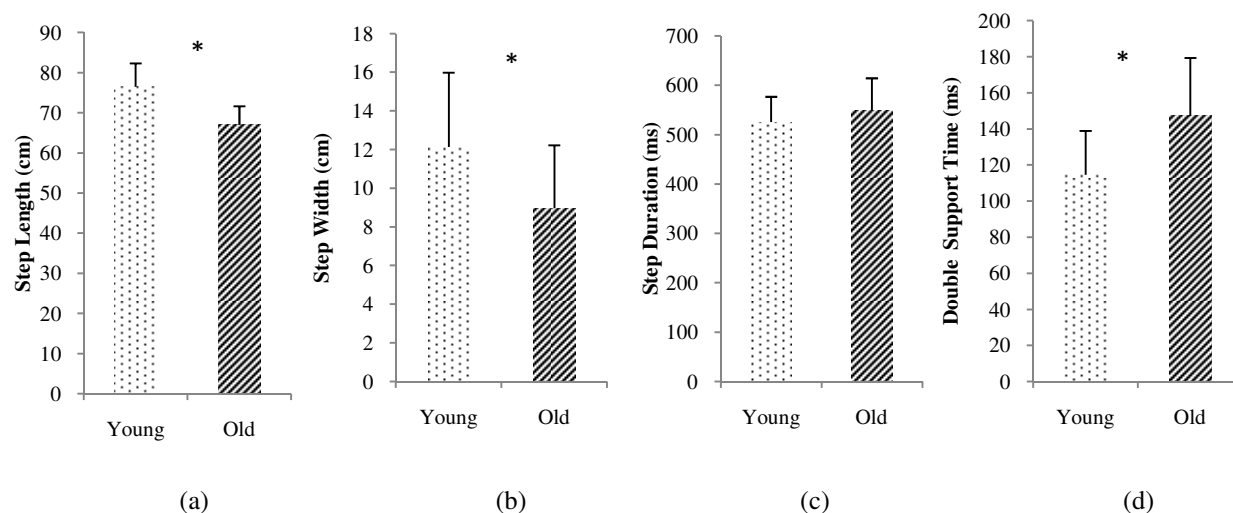

Figure 3.11 Mean and S.D. of (a) first step length (FSL), (b) first step width (FSW), (c) first step duration (FSD), and (d) first double support time (FDST) between age groups

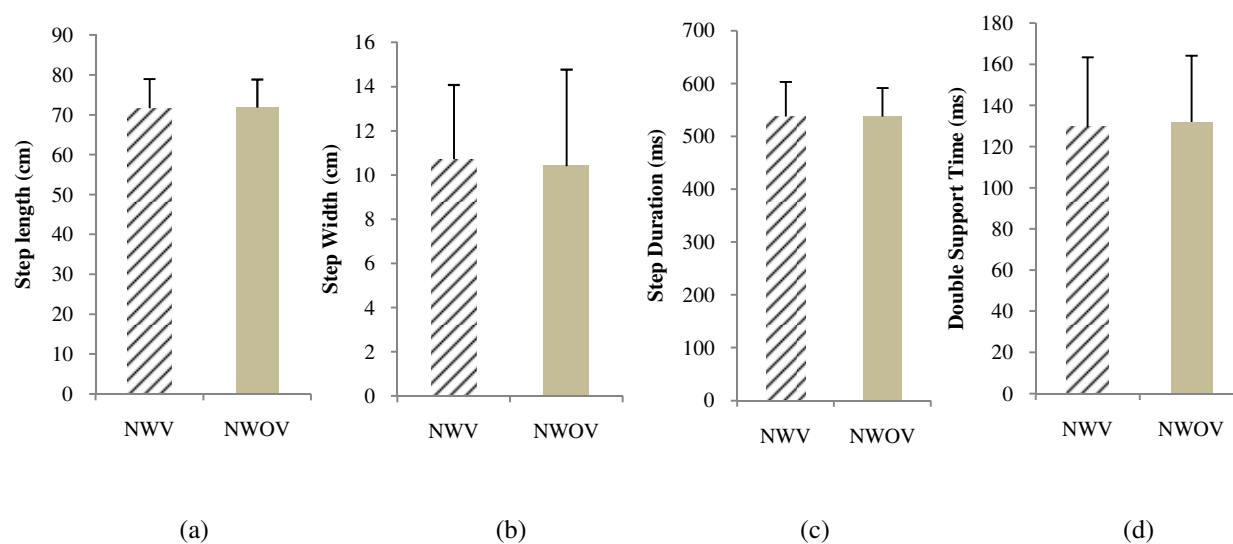

Figure 3.12 Mean and S.D. of (a) first step length (FSL), (b) first step width (FSW), (c) first step duration (FSD), and (d) first double support time (FDST) between NWV and NWOV

For the next step, older adults had a significantly shorter step length ( $F_{(1, 56)} = 44.4352$ ,  $P < 0.0001^*$ ) than younger counterparts, as shown in Figure 3.13. The results also show that older adults had narrower step width, longer step duration and longer double support time than younger adults, but no significant difference between age groups. There was no significant difference of the subsequent step gait characteristics between NWV and NWOV, as shown in

Figure 3.14. However, ANOVA results indicated significant interaction between age groups and visual conditions on next double support time ( $F_{(1, 56)} = 4.0440, P < 0.0492^*$ ), as shown in Figure 3.15.

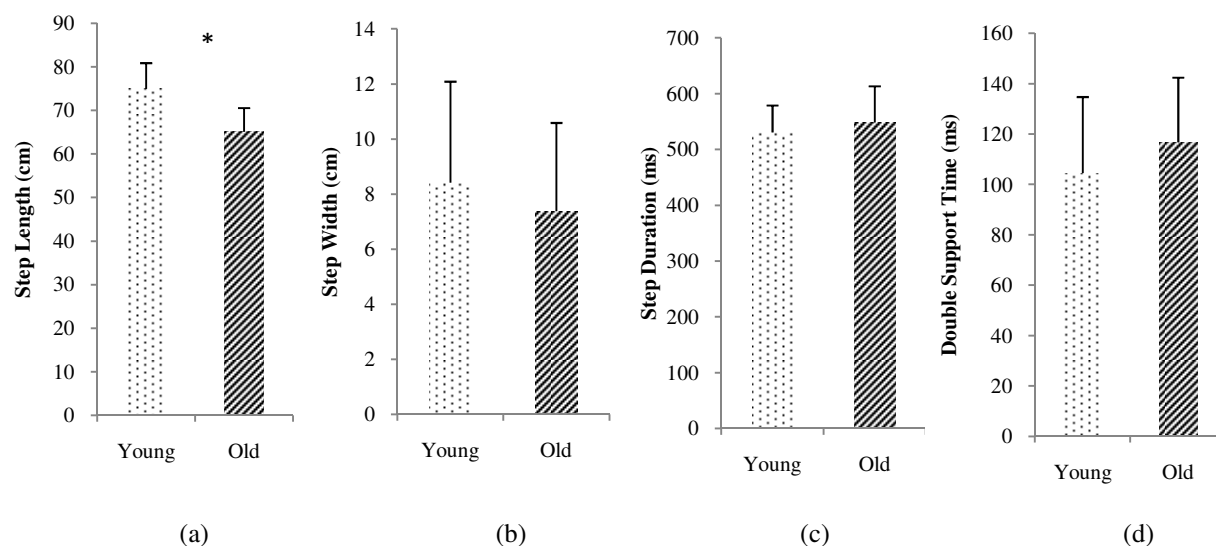

Figure 3.13 Mean and S.D. of (a) next step length (NSL), (b) next step width (NSW), (c) next step duration (NSD), and (d) next double support time (NDST) between age groups

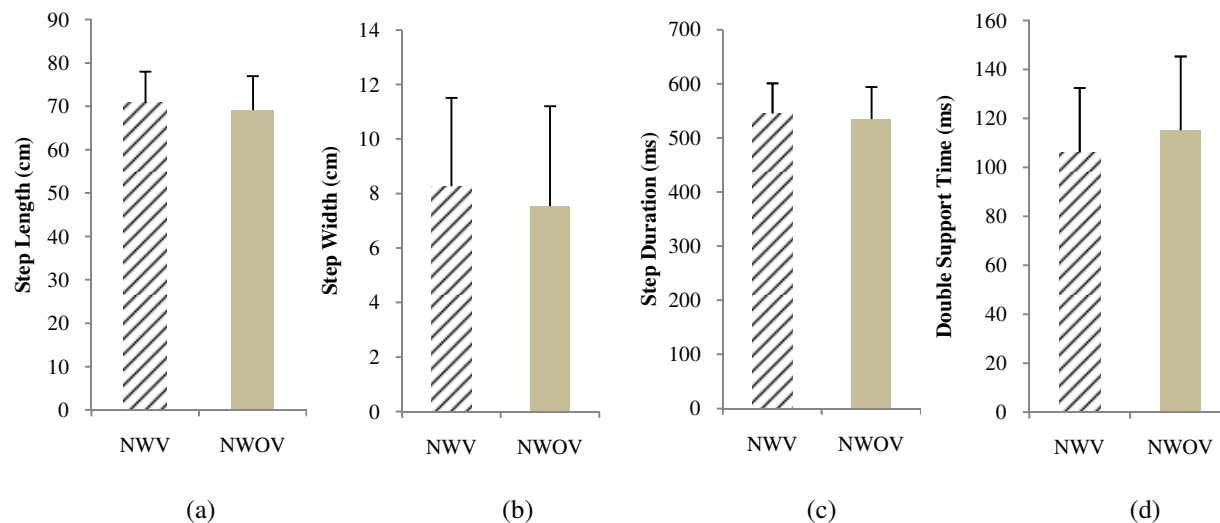

Figure 3.14 Mean and S.D. of (a) next step length (NSL), (b) next step width (NSW), (c) next step duration (NSD), and (d) next double support time (NDST) between NWV and NWOV

Pair-wise comparisons of means were performed to identify differences in next double support time, as shown in Figure 3.16. Next double support time of Old NWOV was significant difference from next double support time of Young NWV, Young NWOV, and Old NWV.

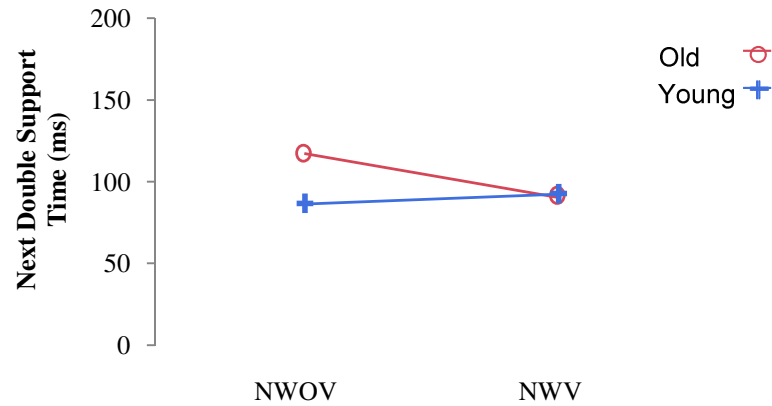

Figure 3.15 Mean plot of next double support time between age groups (Young vs. Old) and visual conditions (NWOV vs. NWV) during normal walking

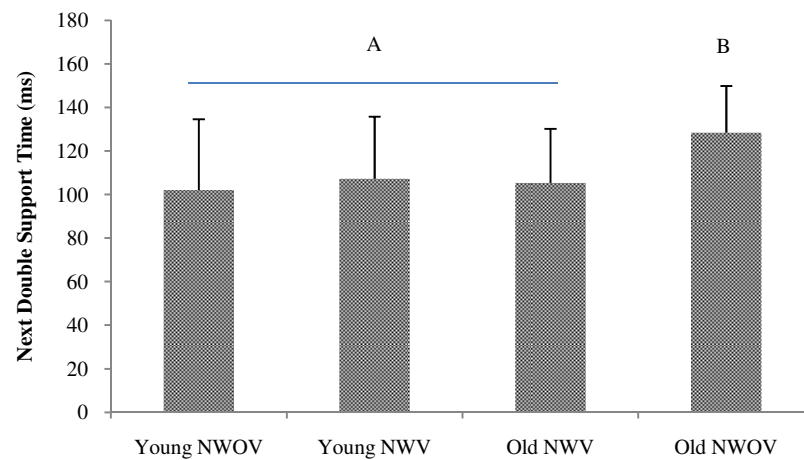

Figure 3.16 Mean and S.D. of next double support time between age groups (Young vs. Old) and visual conditions (NWOV vs. NWV) during normal walking

The means and standard deviations of gait parameters for two age groups (younger and older adults) are reported in Table 3.7.

Table 3.7 Mean  $\pm$  S.D. of gait parameters during NWV and NWOV trials between young and old groups

Gait Parameter	Young		Old	
	NWV	NWOV	NWV	NWOV
First Step Length (cm)	76.50 $\pm$ 5.72	76.59 $\pm$ 6.01	67.00 $\pm$ 5.33	67.15 $\pm$ 4.11
First Step Width (cm)	11.99 $\pm$ 3.48	12.29 $\pm$ 4.29	9.45 $\pm$ 2.79	8.53 $\pm$ 3.67
First Step Duration (ms)	522.59 $\pm$ 59.04	529.07 $\pm$ 43.92	552.96 $\pm$ 69.67	546.67 $\pm$ 61.95
First Double Support Time (ms)	117.41 $\pm$ 26.76	112.04 $\pm$ 21.91	125.74 $\pm$ 26.32	126.67 $\pm$ 26.58
Next Step Length (cm)	75.30 $\pm$ 6.03	74.56 $\pm$ 6.03	66.43 $\pm$ 5.37	63.75 $\pm$ 5.40
Next Step Width (cm)	8.30 $\pm$ 3.26	8.53 $\pm$ 4.15	8.23 $\pm$ 3.35	6.55 $\pm$ 2.90
Next Step Duration (ms)	532.96 $\pm$ 45.06	529.07 $\pm$ 52.59	556.67 $\pm$ 64.42	541.11 $\pm$ 65.58
Next Double Support Time (ms)	107.22 $\pm$ 28.54	102.04 $\pm$ 32.47	105.37 $\pm$ 24.72	128.36 $\pm$ 21.53

### 3.8.3 Postural Adjustments

Two-ways MANOVA between age groups (between-subjects) and visual conditions (within-subject) was performed with ankle, knee, hip, trunk, perturbed and unperturbed shoulder angles at heel-contact. An initial MANOVA indicated no significant difference ankle, knee, hip, trunk, perturbed and unperturbed shoulder angles at heel-contact during NWV and NWOV in both age groups. The means and standard deviations of kinematic angle for the four groups (Young NWV, Young NWOV, Old NWV, and Old NWOV) are shown in Figure 3.17 and listed in Table 3.8. The example of kinematic angles during NWV (solid line) and NWOV (dashed line) normalized from HC to TO shows in Figure 3.18.

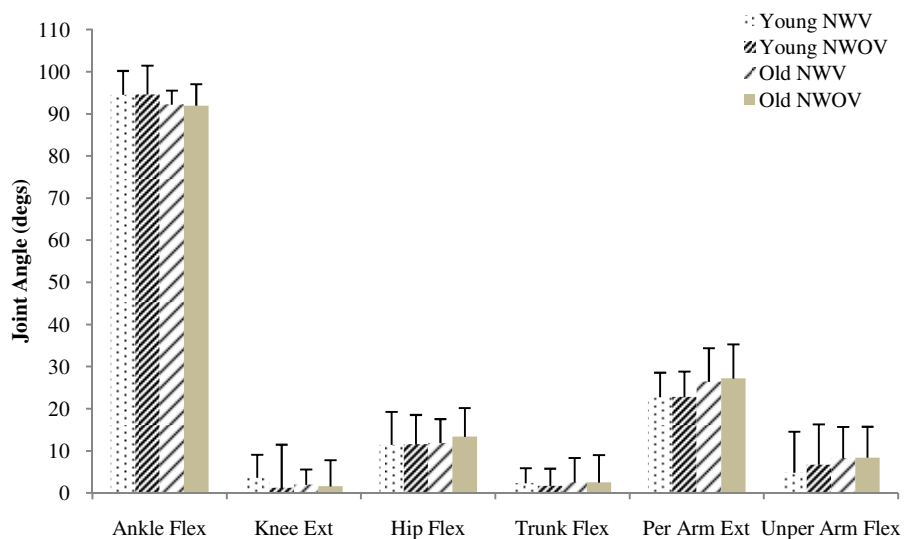

Figure 3.17 Joint angles at heel-contact during NWV vs. NWOV

Table 3.8 Mean  $\pm$  S.D. of joint angles and angular velocities during SWV and SWOV between younger and older groups

Variables	Younger		Older	
	NWV	NWOV	NWV	NWOV
Joint angles (deg)				
Ankle angle at HC (+ = plantar)	94.56 $\pm$ 5.67	94.63 $\pm$ 6.84	92.24 $\pm$ 3.30	91.96 $\pm$ 5.13
Knee angle at HC (+ = flex)	-3.62 $\pm$ 5.45	-1.20 $\pm$ 10.27	-1.96 $\pm$ 3.63	-1.60 $\pm$ 6.19
Hip angle at HC (+ = flex)	11.41 $\pm$ 7.87	11.55 $\pm$ 7.00	11.89 $\pm$ 5.67	13.37 $\pm$ 6.79
Trunk angle at HC (+ = flex)	2.35 $\pm$ 3.57	1.68 $\pm$ 4.11	2.52 $\pm$ 5.80	2.49 $\pm$ 6.52
Per shoulder angle (+ = flex)	-22.76 $\pm$ 5.82	-22.78 $\pm$ 6.04	-26.42 $\pm$ 7.94	-27.20 $\pm$ 8.12
Unper shoulder angle (+ = flex)	4.82 $\pm$ 9.72	6.73 $\pm$ 9.58	8.29 $\pm$ 7.43	8.37 $\pm$ 7.37

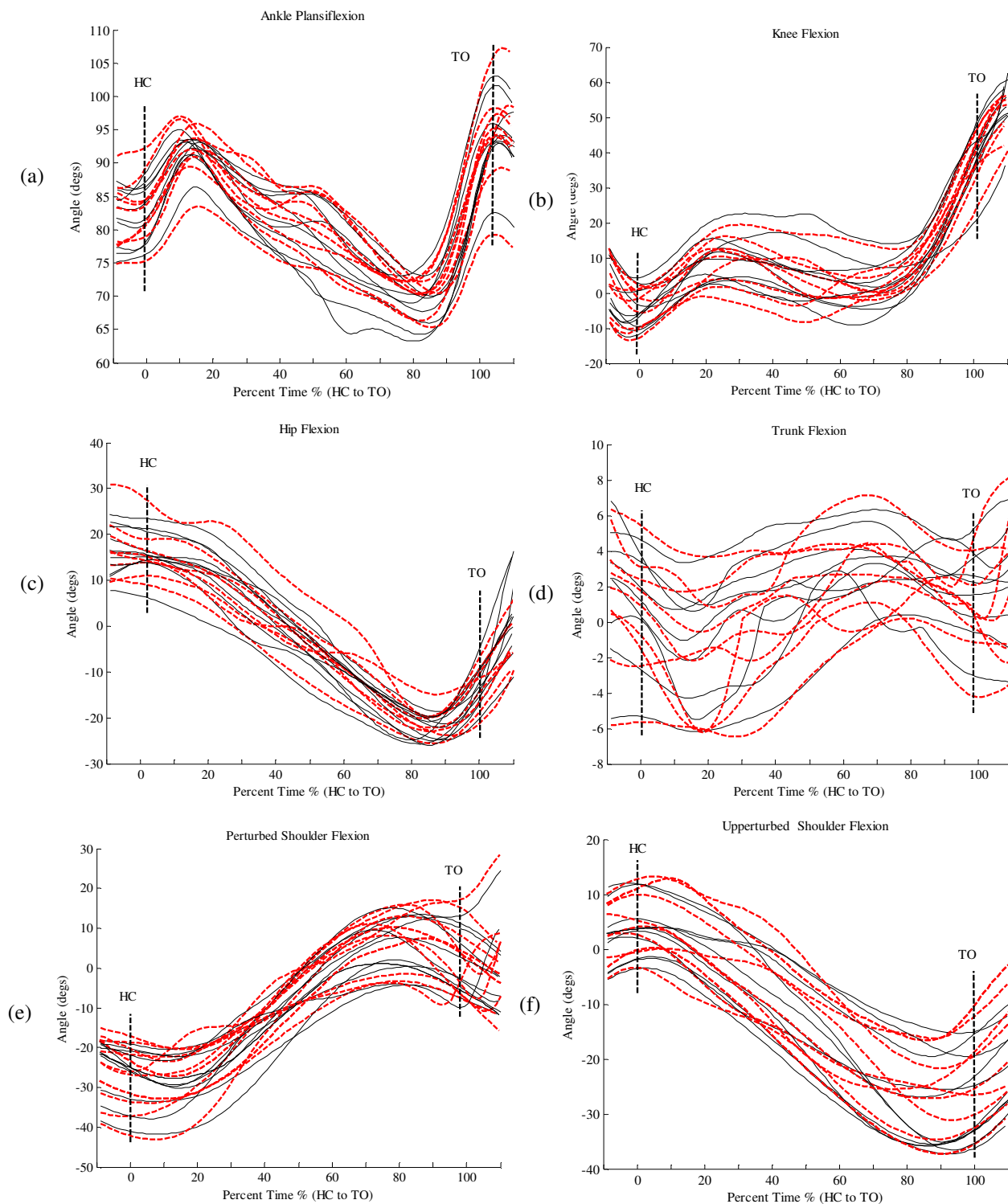

Figure 3.18 Example of joint angles normalized from HC to TO (a) ankle flexion, (b) knee flexion, (c) hip flexion, (d) trunk flexion, (e) perturbed shoulder flexion, and (f) unperturbed shoulder flexion during NWV (solid line) and NWOV (dashed line)

### 3.8.4 Muscle Co-Contraction

To understand the overall effects of age and visual input on muscle co-contraction during walking, MANOVA conducted between age groups and visual conditions with integrated CCI of knee (Vastus Lateralis (VL) and Medial Hamstring (MH)) and ankle (Tibialis Anterior (TA) and Medial Gastrocnemius (MG)) joints at heel contract (HC), mid stance (MS) and toe-off (TO). Logarithmic transformation was used to transform data which were not normally distributed before conducting the MANOVA test. The MANOVA indicated that integrated CCI of the knee and ankle joints was significantly affected by age groups ( $F_{(6, 45)} = 6.4441$ ,  $P < 0.0001^*$ ) with Wilks' Lambda ( $P < 0.0042^*$ ). As such, subsequent univariate ANOVAs were conducted to provide better understanding of how integrated CCI of the knee and ankle joints were influenced by age groups and visual conditions on each dependent variable. Older groups had significant higher integrated ankle CCI at HC ( $F_{(1, 50)} = 27.4572$ ,  $P < 0.0001^*$ ), at MS ( $F_{(1, 50)} = 5.0169$ ,  $P < 0.0296^*$ ), and at TO ( $F_{(1, 50)} = 19.5855$ ,  $P < 0.0001^*$ ) than younger groups, as show in Figure 3.19 (a). The results also indicated significant difference of integrated CCI of the knee at HC ( $F_{(1, 50)} = 3.3403$ ,  $P < 0.0736^\dagger$ ) by visual conditions with  $\alpha = 0.1$ . This finding may suggest that the potential effect of visual input during human locomotion on muscle co-contraction (i.e., stiffness) at the knee joint, as shown in Figure 3.19 (b).

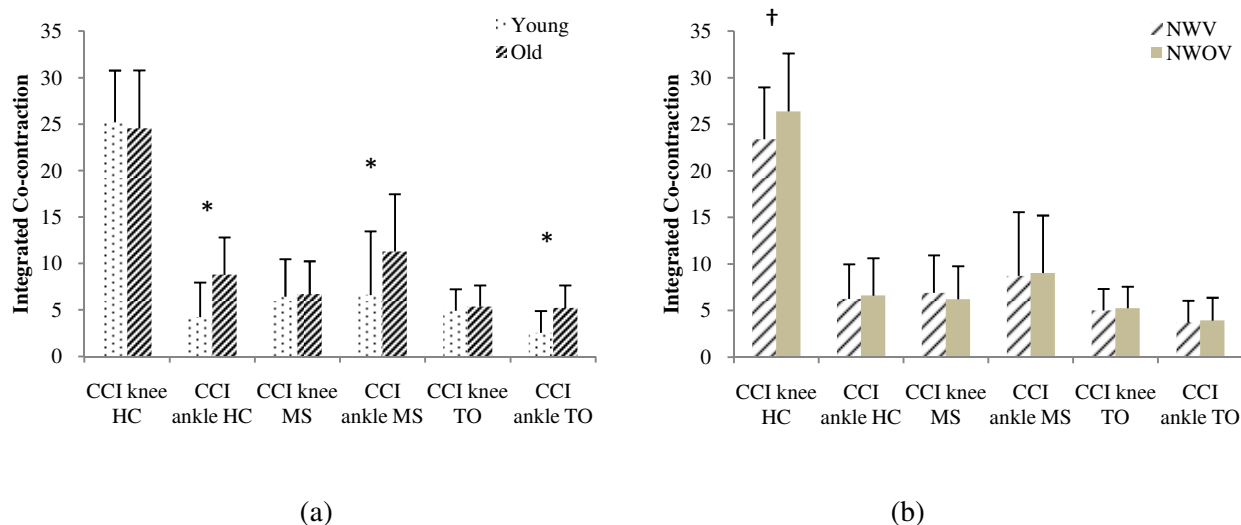

Figure 3.19 Integrated CCI of the knee and ankle joints at HC, MS, and TO for (a) age groups and (b) visual conditions (\*  $p < 0.05$ ,  $^\dagger p < 0.1$ ).



The means and standard deviations of muscle co-contraction for the four groups (Young NWV, Young NWOV, Old NWV, and Old NWOV) are shown in Figure 3.20 and listed in Table 3.9.

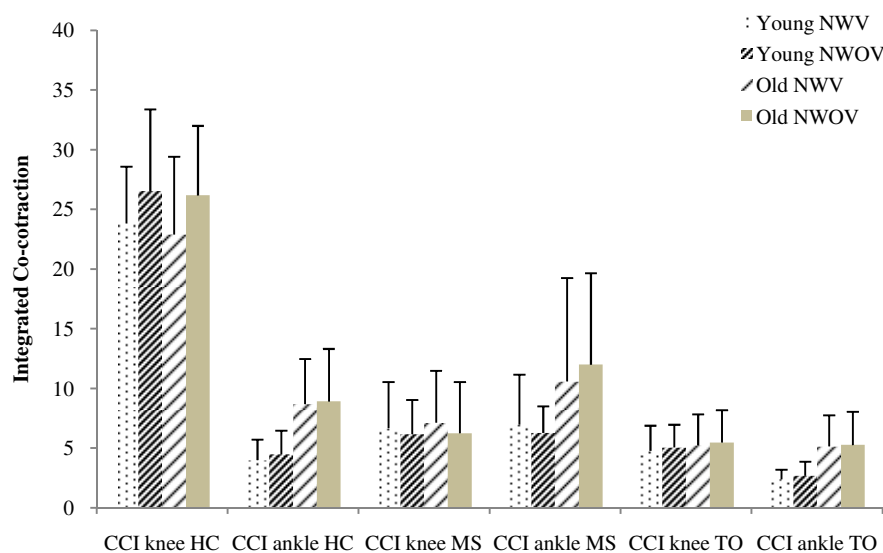

Figure 3.20 Integrated CCI of the knee and ankle joints at HC, MS, and TO for Young NWV, Young NWOV, Old NWV, and Old NWOV

Table 3.9 Mean ± S.D. of muscle co-contraction during NWV and NWOV trials between young and old groups

Integrated co-contraction	Young		Old	
	NWV	NWOV	NWV	NWOV
Knee CCI at HC	23.85 ± 4.76	26.57 ± 6.83	22.91 ± 6.50	26.19 ± 5.82
Ankle CCI at HC	4.00 ± 1.73	4.48 ± 1.98	8.69 ± 3.79	8.91 ± 4.42
Knee CCI at MS	6.67 ± 3.87	6.18 ± 2.88	7.13 ± 4.36	6.25 ± 4.30
Ankle CCI at MS	6.97 ± 4.19	6.28 ± 2.24	10.59 ± 8.67	11.99 ± 7.67
Knee CCI at TO	4.79 ± 2.09	5.07 ± 1.90	5.25 ± 2.59	5.47 ± 52.73
Ankle CCI at TO	2.41 ± 0.80	2.69 ± 1.17	5.15 ± 2.61	5.27 ± 2.78

### 3.9 Discussion

This study examined the effects of age and visual perturbation on gait, posture, and co-contraction at the knee and ankle joints associated with walking on normal floor surfaces. First, the results indicate that age causes changing gait parameters during walking. Temporal loss of visual input (~500 ms) does not affect step length, step width or step duration within age group. However, the loss of visual input increased the subsequent double support time after visual occlusion in the older age group. Second, age and the temporal loss of visual input does not affect posture adjustments (i.e., joint angles) at heel-contact. Finally, older adults increased stiffness at the ankle joint while walking, and loss of visual input increased stiffness at the knee joint at the heel-contact phase of the gait cycle.

The goal of this investigation was to assess the effect of the temporary loss of visual input at the heel-contact could affect the walking pattern of the next step (i.e., subsequence step). The results indicate that next step length, step width, and step duration were not affected by temporally loss of visual input at heel-contact. The results are in agreement with the study of Halleman et al. (2009) which indicated no difference of spatial parameter of gait between open-eyes and closed-eyes walking in short distance. No significant difference of the spatial parameters (step length and step width) of gait can be explained by the concept of a ballistic strategy. The ballistic strategy is adopted during locomotion when the central nervous system anticipates the direction of the future position before the toe-off (Foot A, in Figure 3.21). Roberts (1978) described behavior during locomotion that the body mass is thrown upward and forward at toe-off phase; and it will be caught again during heel-contact. In other words, the gait characteristics of the future foot step (Next Foot A) depends on the pre-structured motor commands before toe-off of the rear foot (Foot A) (Brenière & Do, 1991; Patla, 1997; Roberts & Roberts, 1978). Therefore, visual occlusion before the toe-off does not affect gait characteristics of the subsequent step.

The results also indicate a significant interaction between age and visual condition on the subsequent double support time (i.e., temporal parameter of gait). Halleman et al. (2009) also observed increased double support time during closed-eyes walking without the changing of step length and step width. After the current step is completed (i.e., the mass of body is caught at the heel-contact), the adaptive controller could be applied for the future step as shown in the delay of

Foot B toe-off. However, in this study, the next double support time of Foot B increased the most with older adults during walking without vision. Without visual input, the central nervous system may attempt to gain information from other sensory systems (i.e., reweight process) to predict the direction and position of the subsequent step.

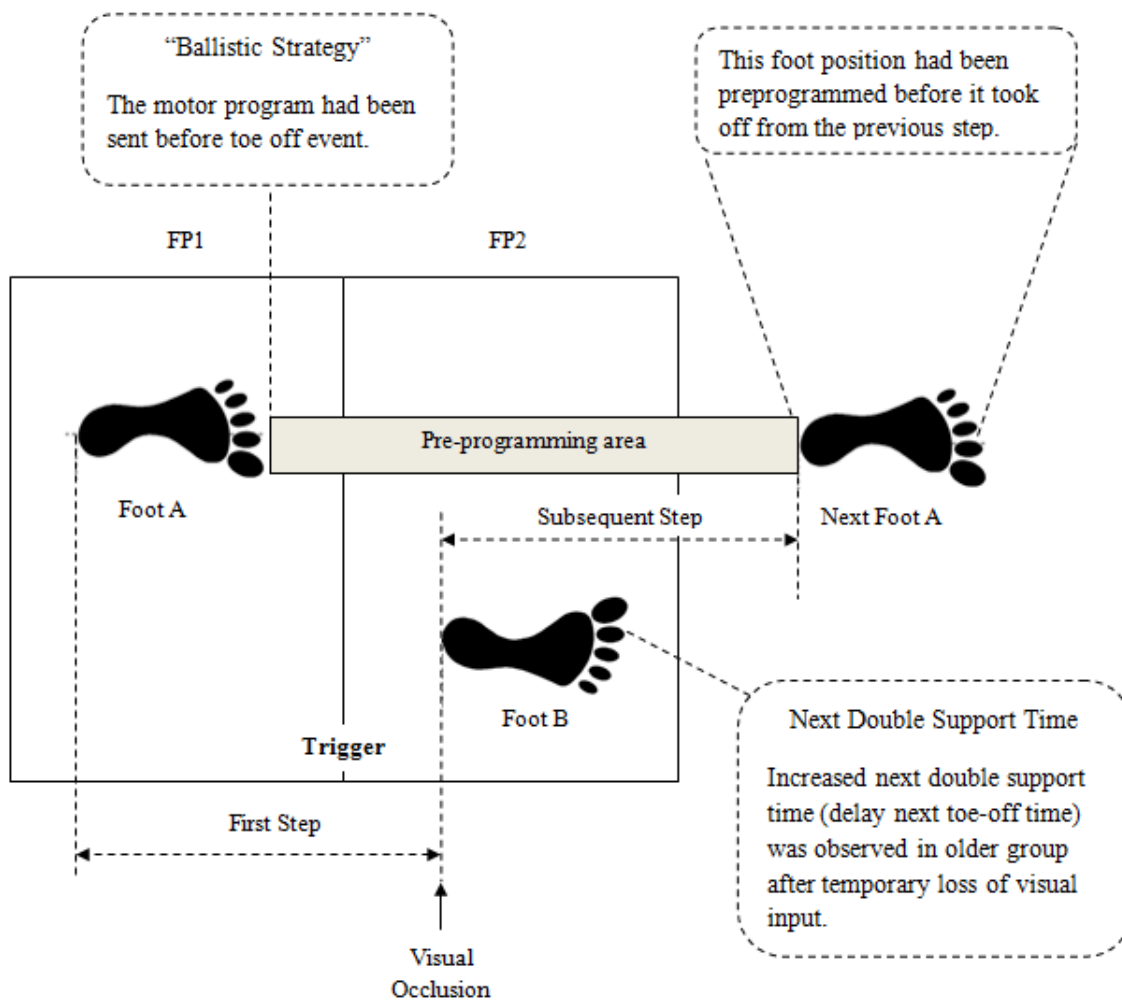

Figure 3.21 A foot position diagram associated with the concept of ballistic strategy

Age-related degradation may cause older adults taking longer time to pre-program the future step by using vestibular and proprioceptive systems. Older adults took longer double support time (i.e., delay Foot B toe-off) during a temporary loss of visual input, which indicated that older adults adopt a more cautious strategy than younger adults. The temporary loss of visual input may cause more challenges for older adults. The cautious strategy, as shown in Figure 3.22, tends to play an important role in an older adults compensation for their physical and

neuronal decline (Guimaraes & Isaacs, 1980). Prokop and colleagues (1997) indicated that the spatial parameters are influenced by the changing of optic flow, whereas the temporal parameters are stable. In this study, visual input has been perturbed by temporary occlusion (not influence optic flow during walking). This may be why no significant differences were found on the spatial parameters. The results associated with perturbed limb joint angles also supports the concept of ballistic strategy as discussed in the spatial parameters of gait. No differences between walking with or without visual input were observed in joint angles (ankle, knee, hip, trunk, and shoulder).

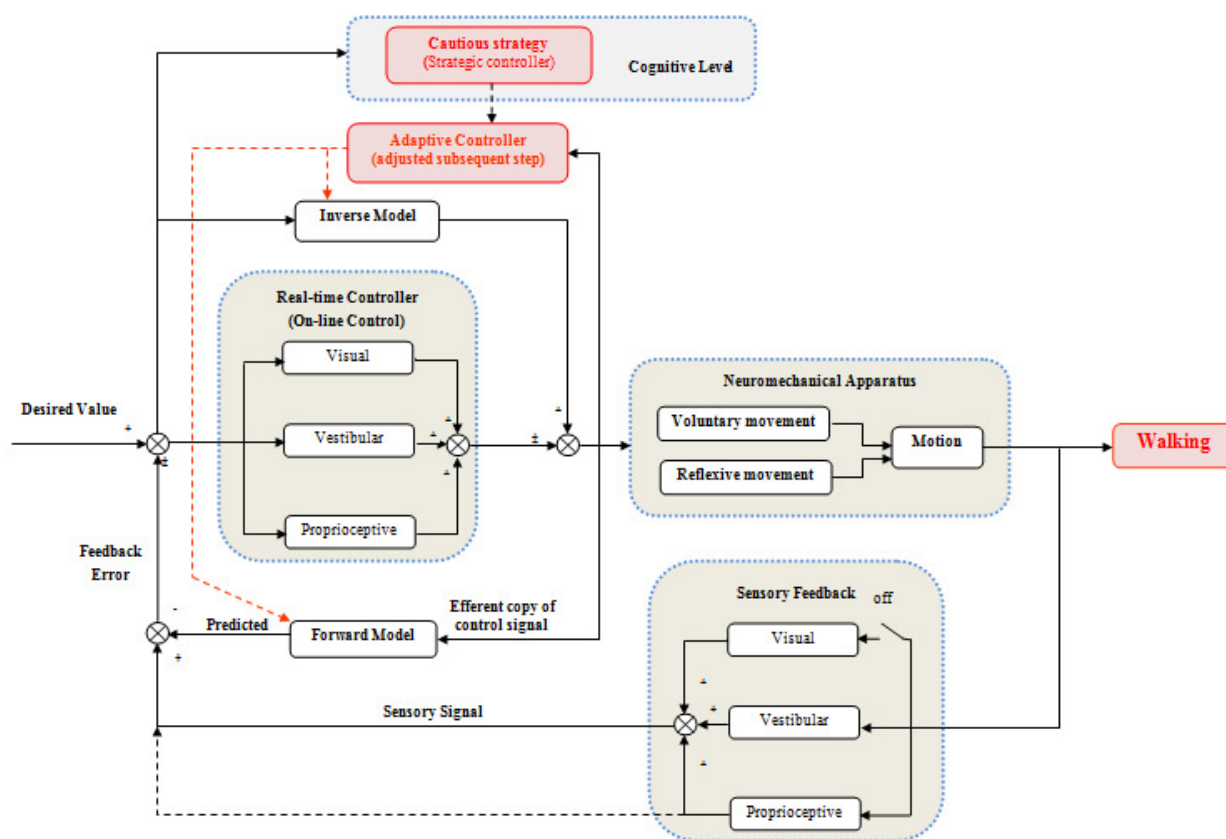

Figure 3.22 Schematic diagram of the basic human control associated with adaptive and strategic controller during walking (adopted from Sicre et al., 2008)

However, the results showed that temporary loss of visual input causes increased muscle co-contraction at the knee joint during the heel-contact event (from -20% to 20% into stance, with HC being 0%). Increased muscle co-contraction indicated the influence of temporary loss of visual input on the joint stiffness. This finding is in agreement with previous studies (Collins &

Luca, 1995; Collins, et al., 1995; Onambélé, et al., 2007). Joint stiffness is reduced while visual input is available; and visual input may serve to reduce the gains of proprioceptive and vestibular systems. The adaptive controller has been used when the perturbation (i.e., temporary loss of visual input) was perceived during locomotion. Increased muscle stiffness may result in reducing flexibility and adaptability during unexpected loss of visual input. Normally, humans utilize visual information to plan and update the motor output during walking.

Figure 3.22 illustrates the internal model during human locomotion with temporary loss of visual input. The inverse model creates the motor command considering the desired state (i.e., as walking forward). Real-time controller (i.e., visual, vestibular, and proprioceptive systems) is integrated to function as an on-line control to perceive changing environmental information. The adjusted motor command from the inverse model and the real-time controller is sent to create movements and to the forward model. This forward model acts as a predictor to anticipate the consequences of the future step of walking from a copy of the motor command (i.e., efference copy). If the motor commands from the forward model (i.e., predicted) and sensory feedback are different, the central nervous system will reprogram the motor output by sending the error signal to the adaptive controller to correct the effect of perturbation (Sicre, et al., 2008). The temporary loss of visual input during human locomotion may influence the reweighting process of sensory feedback controller as well as strategic (cautious strategy) and adaptive controllers in order to create motor command of the future event. Thus increased double support time and co-contraction at the knee joint may be a part of adaptive and strategic controls to prevent the body from potential accidents from temporary loss of visual input (e.g., dark/light adaptation).

And this temporary loss of visual input was more evident among older adults. The results indicated that older adults had significant shorter step length, narrower step width, longer step duration and slower walking velocity than their younger counterparts. Consistent with previous findings (Lockhart, 1997; Lockhart, et al., 2005; D. A. Winter, 1991), a reduction in step length was observed in older groups. No differences between age groups were observed in joint angles (ankle, knee, hip, trunk, and shoulder) neither during walking with or without visual input. Older adults had higher co-contraction at the ankle joint as compared to the younger group. This finding is in agreement with a previous study which indicated that older adults have higher co-contraction at the ankle joint (pair of TA and MG) than younger adults (Okada, Hirakawa, Takada, & Kinoshita, 2001). Higher ankle co-contraction among older adults is not only effect to

ability to detect changing surface (i.e., slippery surface) but also reduce flexibility used in postural adjustments while experiencing perturbations (Chambers & Cham, 2007). Increased muscle co-contraction may be explained by the adaptive control which older adults may use to compensate for the weakness of muscle strength (Tang & Woollacott, 1998). Furthermore, this finding implies that older adults adopt more cautious strategy during walking with in agreement with previous studies (Lockhart, Woldstad, & Smith, 2003; Menz, et al., 2003; Winter, et al., 1990).

The temporary loss of visual input may happen in real world situations, for example, in the moment that we walk from bright sun light outside into the shade area. Our eyes may have difficulty perceiving information from their surroundings. This cautious strategy and adaptive controller may play a role in the increase of double support time to delay toe-off for the subsequent step. Moreover, the knee joint becomes stiff at the heel-contact to prevent the body from a potential accident that may occur from temporary loss of visual input. However, the pros and cons of co-contraction or stiffness are still in controversial. The co-contraction between two pair of muscle groups was found to be the key to reactive recovery during lost balance (Tang, et al., 1998). In contrast, excessive co-contraction may cause reduced flexibility and adaptability in order to regain balance (Horak, et al., 1992). If we walk in a shaded area and step on to a contaminated surface (e.g., water, oil, ice, etc.), the stiffness which occurs as the body response to maintain balance from temporary loss of visual input may cause the poor performance in recover for slip-induced falls. As mentioned earlier, the physical and sensory degradation in older adults may influence the potential hazards in the previous situation. Moreover, older individuals tend to have higher stiffness than younger adults. This stiffness may cause the elderly people to have less flexibility to adjust the body momentum to recover from slips and falls.

In summary, this study provided fundamental knowledge related to the temporary loss of visual input during walking. The human body is able to utilize the adaptive controller and strategies controllers to cope with the temporary loss of visual input. Even after losing visual input, humans have remaining sensory systems (vestibular and proprioceptive systems) to interact with environment changes and maintain balance during unexpected perturbations. Consistently with Torres-Oviedo & Bastian (2010) that the proprioceptive gain increase while walking with temporary loss of visual input. A combination of the temporal loss of visual input

and age-related degradation can increase the potential accidents to the aging population, especially in the situation where hazards are presented at the same time of diminished visual input. Human responses such as increased stiffness may be a positive response to assist us to regain balance. On the other hand, stiffness may be a negative response by restricting human movement and reducing flexibility during recovery from a loss of balance. The investigation concerning the effect of temporal visual loss and unexpected slip perturbation on human responses is presented in Chapter 4.

## CHAPTER 4

### **STUDY II – The Age-Related Effects of Visual Input on Biomechanical Changes During Unexpected Slip Perturbations**

#### **4.1 Objective**

The objective of this study is to investigate the age-related effects of visual input on biomechanical changes during unexpected slip perturbations (dynamic stability). Slip severity, postural adjustments, and muscle activation patterns during two visual input conditions were determined by using the combination of standard methodological approaches. These parameters have been used to explain the effect of visual input on how well individuals can detect a slip and recover from a fall.

#### **4.2 Participants**

##### ***4.2.1 Sample Size Estimates***

To estimate sample size, power analysis was performed using the results of the pilot study by focusing on sample sizes that are large enough to determine differences between slip distance during slip with visual input and without the visual input. The general test statistic for the two populations is the standard two-sided t test, for which the power of the test (Neter, 1996) is given by:

$$\text{Power} = P \{ |t^*| > t(1 - \alpha/2; n-2 \mid \delta) \}$$

$$\delta = |A - B| / \sigma\sqrt{2/n}$$

where:

$\delta$  is the noncentrality parameter, or a measure of the difference between the means of A and B (slip distance difference).



$\sigma$  is the standard deviation of the distribution of slip distance, and  $n$  is the number of participants.

Means and standard deviations of slip distances obtained from the pilot study were used to compute the required sample sizes, respectively. Table 4.1 summarizes the required sample size for detecting significant differences in slip distance I and II (SDI and SDII) given  $\alpha = 0.05$  and  $\beta = 0.30$ . The final sample size was determined as  $n = 15$ , as the maximum number of sample size from SDII.

Table 4.1 Summary of the required sample size for detecting significant differences between slip with visual input and without visual input given  $\alpha = 0.05$  and  $\beta = 0.30$ .

	SDI	SDII
$\delta(\text{cm})$	1.65	3.03
$\sigma(\text{cm})$	1.45	3.20
n	13	15

### 4.3 Apparatus

The apparatus for study II is similar to Study I. One additional apparatus was added to Study II to create slip perturbation. The entire walking track was covered with vinyl tile (the dynamic coefficient of friction (DCOF) of the dry vinyl floor surface is 1.80). The slippery surface was prepared by applying a water and jelly mixture (1:1) to reduce the dynamic coefficient of friction (dynamic COF) to about  $0.11 \pm 0.04$  (Grönqvist, Hirvonen, & Tuusa, 1993; Lockhart, et al., 2003). The DCOF was measured using a standard 4.54 kg (10 lb) horizontal pull slip-meter with a rubber sole material on the force plates (Perkins, 1978).

## 4.4 Protocol Study II

Participants were asked to wear the liquid crystal display glasses (PLATO) and an outfit of laboratory clothing and shoes. When the PLATO was deactivated (“open”, transparent), near-complete field-of-view was provided. Then, twenty-six markers were attached to anatomical landmarks of the lower extremities, trunk, arms, and head (head, ears, acromioclavicular joint, acromion, lateral humeral condyle, ulnar styloid, head of the third metacarpal, anterior superior iliac spine (ASIS), lateral femoral condyle, calcaneus, malleolus, and base of the second metatarsal). The marker configuration was adopted from previous studies including the most recent publications (Liu & Lockhart, 2006; Lockhart, et al., 2005). Bipolar Ag-AgCl surface electrodes were placed over Vastus Lateralis (VL), Medial Hamstring (MH), Tibialis Anterior (TA) and Medial Gastrocnemius (MG) muscles of the both lower extremities.

Another reflective marker was attached at the right ankle as described in Study I. A photoelectric reflective sensor was used to detect the swing phase before the right heel-contacted the slippery surface. A signal from the glass controller was sent to the wireless receiver to change the status of the glasses from transparent to opaque to occlude visual input for approximately a half of second ( $\sim 573 \pm 2.15$  ms). This period of time is matched to an approximated time of slip-stop from previous studies (Lockhart, 2008; Parijat, 2009). The PLATO provided complete occlusion of both central and peripheral vision when the PLATO was activated (“closed”, opaque). A LabView program was designed to synchronize the data collection from the motion analysis system, force plates, and glasses controller. The participants were unaware of the position of this surface as the force plates were covered with the same vinyl as the walkway. This is an approach used in several previous slip and fall studies (Liu & Lockhart, 2006; Lockhart, et al., 2005).

During the experiment, participants were required to wear an overhead safety harness at all times to protect them from potential injury. Participants were instructed to look straight ahead and walk naturally at a self-selected pace. Next, participants were asked to practice walking as the experimenters varied the starting point to ensure proper foot contact. Five normal walking trials were conducted as baseline trials. Then, another gait trial was conducted with an unexpected slip perturbation with visual input (SWV) or an unexpected slip perturbation without visual input (SWOV).

In this study, each participant experienced two slip perturbations (within subject, visual input conditions). After undergoing the first unexpected slip perturbation with or without visual input, participants might become aware of the slip perturbation in the same session. To minimize potential learning effects, the study was divided into two sessions. Each session was performed on separate days. After the first slip session, participants were brought back to perform the second slip session after a gap of at least two weeks.

#### 4.5 Data Analyses

The coordinated force plates and markers data were filtered by low-pass filter using fourth order, zero lag, Butterworth filter at a cut of frequency of 6 Hz (Liu & Lockhart, 2006). The EMG data were filtered by band pass filter at frequency between 10-500 Hz (Chambers & Cham, 2007). The band pass filtered data rectified and low-pass filtered using a fourth order, zero lag, Butterworth filter with a 10 Hz cut-off frequency to create a linear envelope (Marigold, et al., 2003). Heel-contact (HC) and Toe-off (TO) of the perturbation limb were identified from the ground reaction forces. The analyses were performed during the stance phase from HC to TO, as previous studies (Chambers & Cham, 2007; Marigold, et al., 2003; Parijat, 2009).

#### 4.6 Experimental Design

The experimental design matrix shows in Table 4.2. Two independent variables include age groups (young and old individuals) and visual input conditions (with and without visual input).

Table 4.2 The experimental design matrix for study II

	Slip with visual input (SWV)	Slip without visual input (SWOV)
Young Individuals	P1-P15	P1-P15
Old Individuals	P16-P30	P16-P30

#### 4.6.1 Independent Variables

Based on the study I experiment design as shown in Table 4.2, a mixed-factor multivariate analysis of variance (MANOVA) was conducted where age was a between-subjects factor and visual conditions was within-subject factors. Using the Wilks' Lambda test, the MANOVA allowed for determination of which factors and relevant interactions had significant effects on the multiple dependent variables as a whole (i.e., slip severity, kinematic angular, EMG activity, and response time). Since a global effect did not contain information about how each of the dependent variables was affected, a statistically significant main effect or interaction effect found in the MANOVA test triggered subsequent univariate analysis of variance (ANOVA) to elucidate the effect on each of the dependent variables. Thus, following the MANOVA test, subsequent univariate ANOVAs (mixed factor design) were conducted separately for each dependent variable. The statistical model of a two-way mixed-factor ANOVA is shown below:

ANOVA table is provided in Table 4.3. The structural model for *the mixed factor ANOVA design* is given below (A-between subjects and B-within subject).

$$Y_{ijkl} = \mu + \alpha_i + \beta_j + \gamma_{k(i)} + \alpha\beta_{ij} + \beta\gamma_{jk(i)} + \varepsilon_{l(ijk)}$$

where:

$Y$  is observation

$\mu$  is population mean

A is a between-subjects variable (age group:  $i = 2$ )

B is a within-subject variable (visual input:  $j = 2$ )

S is the number of the subject in each group ( $k = 15$ ) and

$\varepsilon$  is random error.

Table 4.3 Source and Error terms for mixed-factor ANOVA

Source	df	SS	MS	E{MS}	F
<u>Between</u>					
A	a-1	SSA	MSA	$bn\sigma_{\alpha}^2 + b\sigma_{\gamma}^2 + \sigma_{\epsilon}^2$	MSA/ MSS(A)
S(A)	a(n-1)	SSS(A)	MSS(A)	$b\sigma_{\gamma}^2 + \sigma_{\epsilon}^2$	
<u>Within</u>					
B	b-1	SSB	MSB	$an\sigma_{\beta}^2 + \sigma_{\beta\gamma}^2 + \sigma_{\epsilon}^2$	MSB/ MSBS(A)
BxA	(a-1)(b-1)	SSBA	MSBA	$n\sigma_{\alpha\beta}^2 + \sigma_{\beta\gamma}^2 + \sigma_{\epsilon}^2$	MSBA/ MSBS(A)
BxS(A)	a(b-1)(n-1)	SSBS(A)	MSBS(A)	$\sigma_{\beta\gamma}^2 + \sigma_{\epsilon}^2$	
<u>Total</u>	abn-1	SS <sub>Total</sub>			

*Note:* The error terms are grouped with the effects being tested. Based on the E(MS), the S(A) error term is grouped with A as a between-subjects effect, and the BxS(A) error term is grouped with both B and BxA as a within-subjects effect.

## 4.6.2 Dependent Variables

### 4.6.2.1 Slip Severity

The vertical ground reaction force, exceeding 10 N and minimum position of heel marker position was used to verify the instant of heel-contact in this experiment. Slip distances have been used as a measure of slip severity in numerous studies (Brady, J. Pavol, Owings, & Grabiner, 2000; Lockhart, et al., 2003). Slip distances, shown in Figure 4.3, are divided into SDI, SDII, and SDIII. The relative sliding heel velocity along with the slip distances is used to predict the severity of a slip leading to a fall.

*SDI*: Slip-start point of SDI begins after heel-contact when the first non-rearward positive acceleration of the foot is identified. This SDI is then the distance traveled by the heel from this point of non-rearward positive acceleration to the time of the first peak in heel acceleration, slip-stop point of SDI. The SDI was calculated using the general distance formula shown in following equation:

$$SDI = [(X_2 - X_1)^2 + (Y_2 - Y_1)^2]^{1/2}$$

SDII: Slip-start point of SDII begins at the slip-stop point of SDI. Slip-stop for SDII is the point at which the first maximum horizontal heel velocity occurs after the start of SDII. The SDII distance was calculated using the distance formula as SDI.

SDIII: Slip-start point of SDIII begins at the slip-stop point of SDII. Slip-stop for SDIII is the point when horizontal heel velocity reduced to zero after the first maximum horizontal heel velocity. The SDIII distance was calculated using the distance formula as SDI.

SHV: Sliding heel velocity of the heel after heel-contact was calculated by mean of the instantaneous heel velocity from the slip-start point to peak heel slide velocity (PSHV) points. The horizontal heel velocity was obtained from the heel marker position data. PSHV is defined as the peak heel velocity after the slip-start point, shown in Figure 4.1.

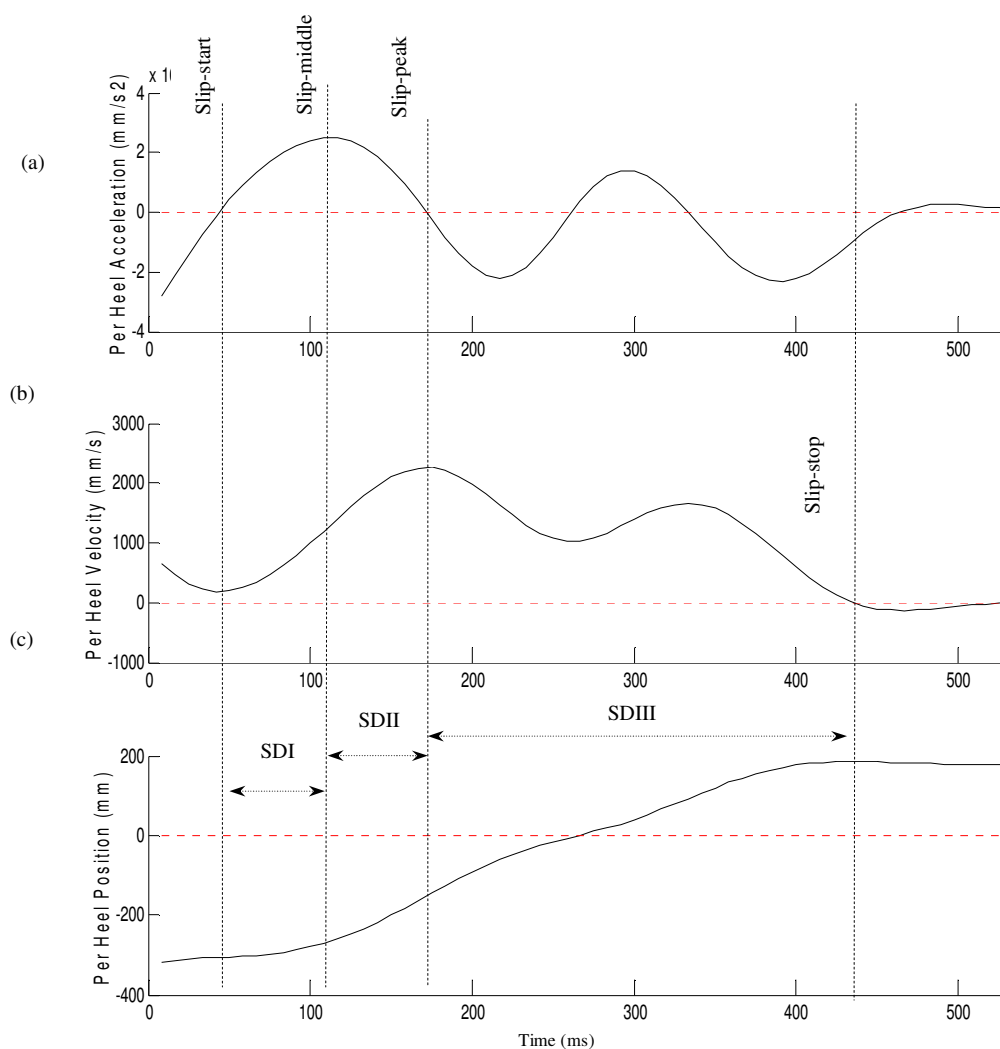

Figure 4.1 Composite views of the heel dynamics during a slip response on the slippery floor

#### 4.6.2.2 Postural Adjustments

Joint angles (trunk, hip, knee, and ankle joint angle) of the slipping limb were calculated to quantify the effect of visual input on angular kinematics. Figure 4.2 shows the posture model with the joint angles on the sagittal plane. Trunk flexion angle was defined by the angle between trunk and vertical. Hip flexion angle was defined by the angle between pelvis and thigh. Knee flexion angle is the angle between the thigh and shank segments of the leg. The ankle dorsiflexion angle was defined by the angles of the shank and foot segments. The lower extremity 2D joint angles (trunk, hip, knee, and ankle) were calculated using methods described previously (Lockhart & Liu, 2006; Parijat, 2009). Heel-contact (HC) and Toe-off (TO) of the perturbation limb were identified from the ground reaction forces. The analyses were performed during the stance phase from HC to slip-stop. All joint angles were calculated as described in Study I.

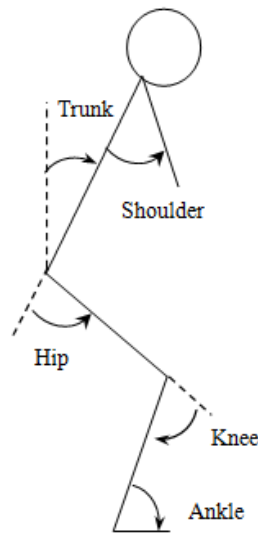

Figure 4.2 The posture model describes the position of the body segments with the following angles on the sagittal plane: shoulder flexion angle, trunk flexion angle, hip flexion angle, knee flexion angle, and ankle dorsiflexion angle.

#### Angular Velocity:

The joint angular velocity was calculated by using each joint angle described above. The angular velocity utilized the linear finite difference equation during a successful step (from HC to slip-stop). The rotational velocity formula is as followed:

$$\omega = \Delta\theta / \Delta t$$

$$\omega_i = (\theta_{i+1} - \theta_{i-1}) / 2\Delta t$$

where  $\theta$  is a joint angle at frame  $i$ ,  $\omega$  is an angular velocity, and  $t$  is 1/120 second per frame.

#### 4.6.2.3 EMG Measures

EMG analysis has been used to study the neuromuscular characteristics of reactions elicited in response to a slip perturbation. Studies reported that during slip event the lower leg and thigh muscles in both the perturbed and unperturbed limbs demonstrated earlier onset, higher magnitude, and longer activations compared to normal gait (Tang & Woollacott, 1998; Tang, et al., 1998). These neuromuscular reactive responses were observed about 140-246 ms after the heel-contact to a slippery surface (Marigold, et al., 2003).

Moreover, ankle and knee muscle co-contraction increased with expected slip perturbations (Marigold, et al., 2003). These co-contractions especially at the ankle may be beneficial to decrease the risk of a hazardous slip. Increased co-contraction at the ankle may play a role in controlling foot positioning (Hof, et al., 2005). Data from slip trials (SWV and SWOV) were time normalized using the stance duration of the baseline trial. The normalized time was computed with respect to the stance leg with 0% being HC and 100% at TO. EMG data were normalized within subject with respect to calculated average maximum value across the normal walking during gait cycle (Chambers & Cham, 2007). In this study, four muscles were assessed Vastus Lateralis (VL), Medial Hamstring (MH), Tibialis Anterior (TA) and Medial Gastrocnemius (MG) muscles of the lower extremities. These muscles were selected because of their agonist/antagonist relationship; and they were based on previous slip studies (Chambers & Cham, 2007; Parijat, 2009). The following dependent variables were utilized to evaluate the neuromuscular changes in the lower extremities of young and old individuals during SWV and SWOV:

#### Onset and duration time

Five control normal walking trials prior to the first slip trial were used to create the normal ensemble average profile (Chambers & Cham, 2007; Marigold, et al., 2003). A three-step process were applied to create the ensemble average profile for a number of stance (Frigo &



Shiavi, 2004). First, the interval time from heel-contact (HC) to toe-off (TO) was scanned because of the stance duration varies. Heel-contact was determined from the vertical ground reaction force traces using a 10 N threshold. The second step was to normalize the time scales of each linear envelop at least 256 points which is a sufficient number (Frigo & Shiavi, 2004). Finally, all of linear envelops were averaged together in an ensemble manner, as shown in Figure 4.3.

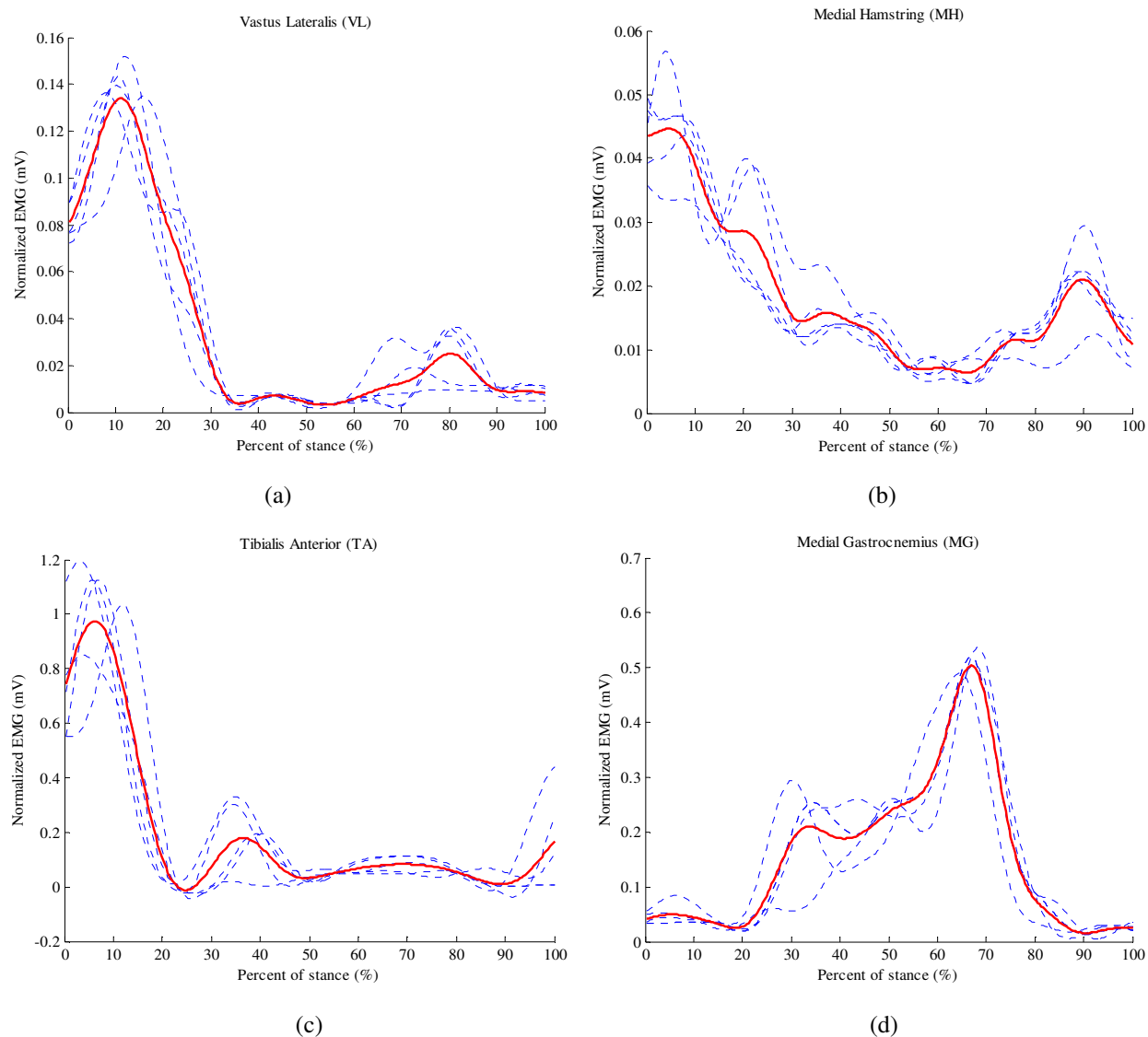

Figure 4.3 Example of muscle EMG activity during normal walking (dashed line) and normal ensemble average profile (solid line) of (a) Vastus Lateralis (VL), (b) Medial Hamstring (MH), (c) Tibialis Anterior (TA) and (d) Medial Gastrocnemius (MG) during stance phase (HC to TO)

Muscle activity onset and duration were determined using a threshold of two standard deviations ( $\pm 2S.D.$ ) above the difference activity in between normal walking and each slip trial (SWV and SWOV) before HC (onto the slippery surface) (Chambers & Cham, 2007). Each muscle response profile for a slip trial was determined by subtracting the ensemble average profile of the normal walking trials from the slip trials. The onset and duration of each muscle burst for 2 seconds (Marigold, et al., 2003; Marigold & Patla, 2002) following the heel-contact were calculated using a custom built program in MATLAB 7.0.1.

### Muscle co-contraction

Each EMG activity was peak normalized within subject using the ensemble average during the gait cycle (Kadaba, et al., 1989). Then, co-contraction index (CCI) was calculated by the following equation (Rudolph, et al., 2001; Rudolph, Schmitt, & Lewek, 2007):

$$CCI = \frac{LowerEMG_i}{HigherEMG_i} \times (LowerEMG_i + HigherEMG_i)$$

where  $LowerEMG_i$  refers to the less active muscle at time  $i$

$HigherEMG$  refers to the more active muscle at time  $i$

The ratio of the EMG activity of TA/MG and VL/MH was considered in this study. The ratio is multiplied by the sum of activity found in the two muscles. Integrated CCI was calculated by integrating area under CCI curve from previous equation. This method does not identify which muscle is more active; rather it provides an estimate of relative activation of the pairs of muscles as well as the magnitude of the co-contraction.

#### 4.6.2.4 Response Time associated with Slip Events

The rapid response of the unperturbed foot and arms after slip-start assists in recovering from slip-induced falls by increasing the base of support and bring the COM back within the base of support respectively (Lockhart, 2008; Marigold, et al., 2003). The following variables will be utilized to measure the response time of the unperturbed foot and arms after the slip is initiated.

##### Perturbed foot measures

Slip-start point was defined after heel-contact when the first non-rearward positive acceleration of the foot is identified. Slip-peak point was defined by the peak sliding heel velocity (Lockhart, et al., 2005). Slip-stop point was defined as the instant when the forward heel velocity decreases to zero after slip-peak point (Lockhart, 2008). Figure 4.4 illustrates foot response time associated with the perturbed foot.

##### Unperturbed foot measures

Toe-off was defined as a minimum of the toe vertical position after slip-start point. Foot-onset provides timing to explain how fast the unperturbed foot responded to the slip perturbation. Foot-onset was defined as the instant when the toe of the unperturbed foot reached peak vertical velocity after toe-off (Lockhart, 2008). Foot-down provides timing information when the unperturbed foot started to establish a wider base of support in order to maintain balance. Unperturbed foot reaction time was defined as time between foot-onset and foot-down (Lockhart, 2008). Foot-down was defined as the instant when the toe vertical velocity reduces to its first minimum after foot-onset. Figure 4.5 illustrates foot response time associated with the unperturbed foot.

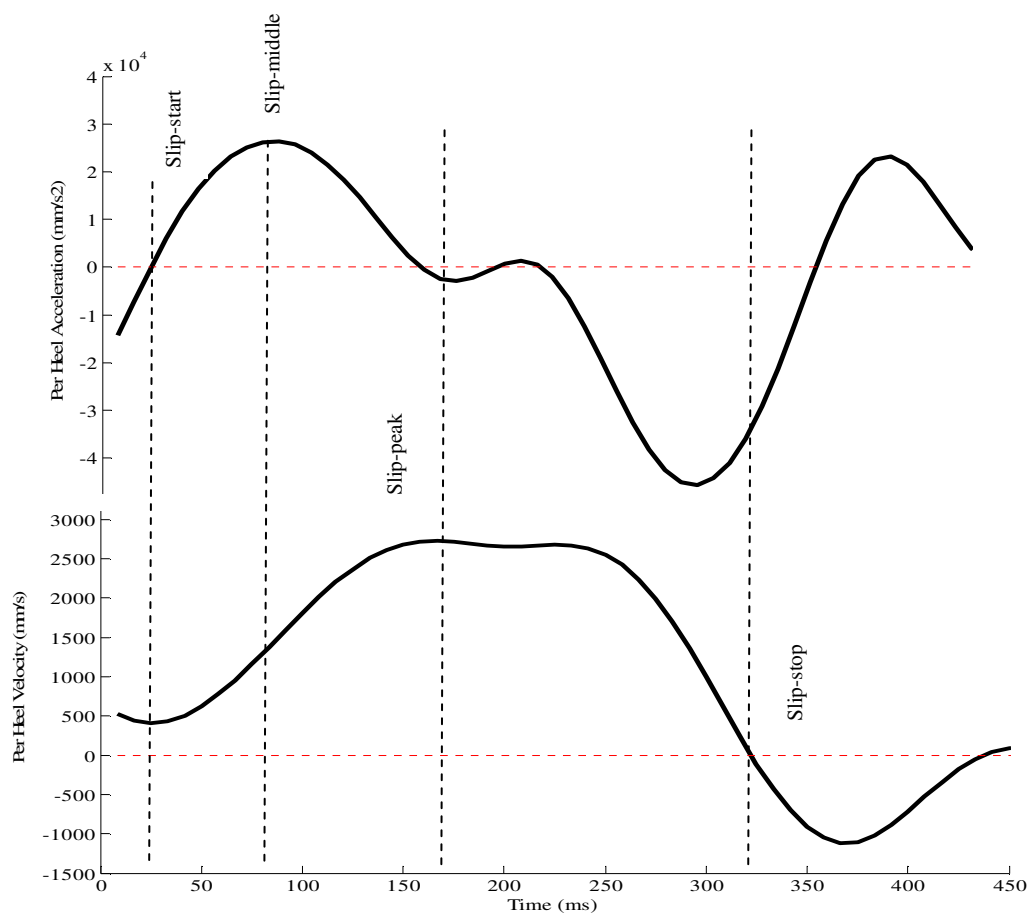

Figure 4.4 Example of perturbed foot response time during slip

#### Perturbed and unperturbed arm measures

Perturbed arm and unperturbed arm-onset was defined as increasing in peak jerk to elevate both the arm upward and forward after slip-start point (Lockhart, 2008; Marigold, et al., 2003). Perturbed arm and unperturbed arm-offset was defined as the instant when the arm velocity decreases to zero after arm-onset point and the wrist vertical position travels to a maximum position. Figure 4.6 illustrates response time associated with arm movements.

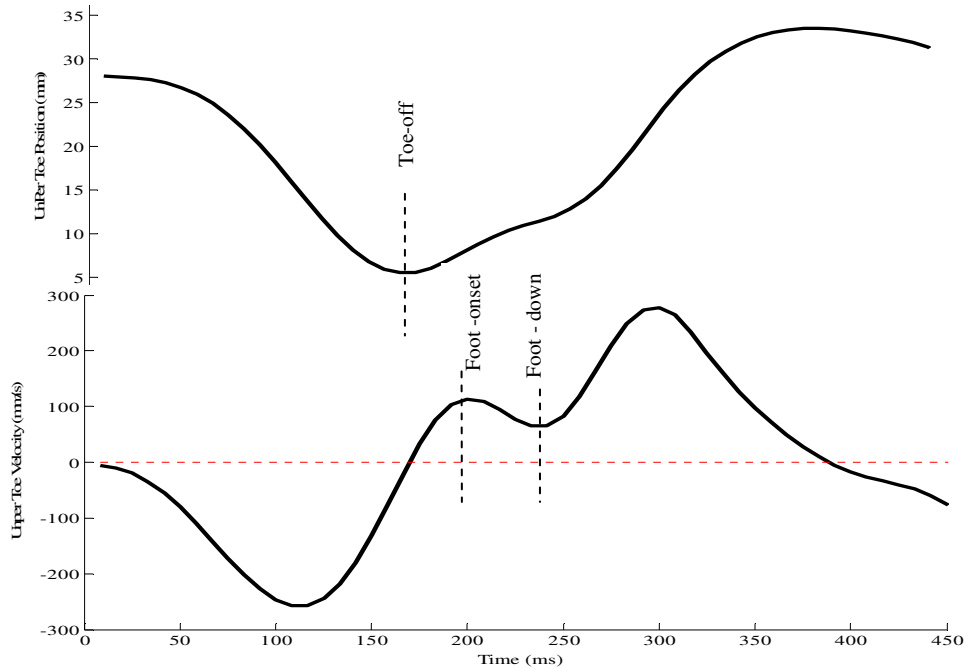

Figure 4.5 Example of unperturbed foot response time during slip

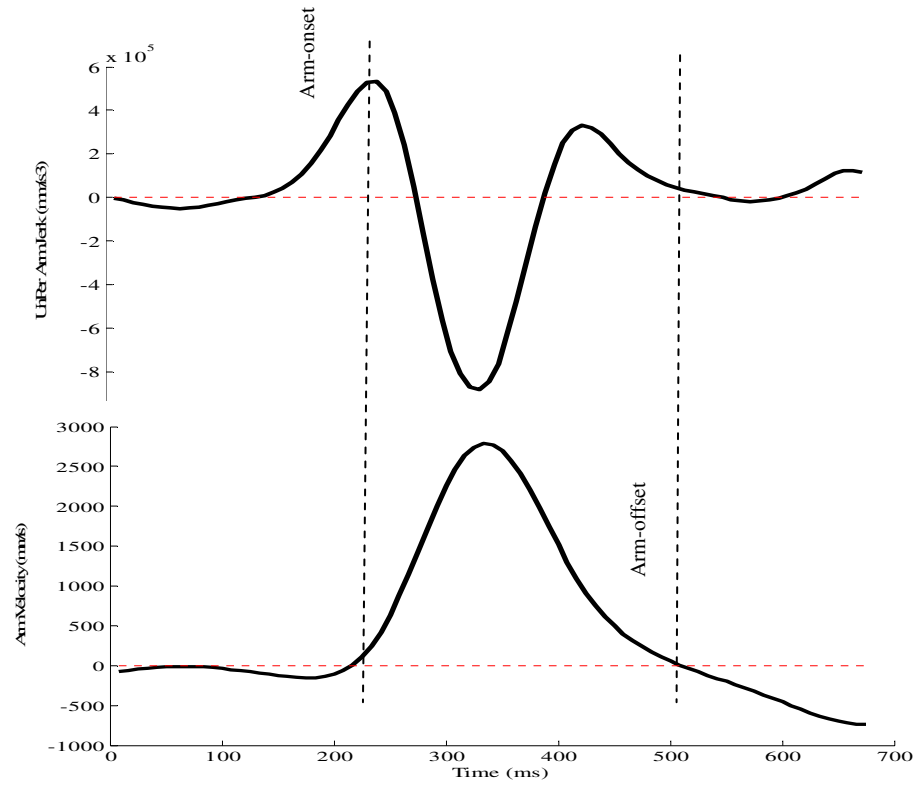

Figure 4.6 Example of arm response time during slip

## 4.7 Statistical Analyses

To determine the effect of age (young vs. old) and visual input during unexpected slip perturbations (SWV vs. SWOV), several dependent variables were measured and calculated in terms of slip severity, reaction time, kinematic adjustments, and muscle activation patterns. A mixed-factor multivariate analysis of variance (MANOVA) was conducted where age was a between-subjects factor and visual conditions were within-subject factors.

Using the Wilks' Lambda test, the MANOVA allowed for determination of which factors and relevant interactions had significant effects on the group of dependent variables (i.e., slip distance measures, lower and upper extremities response times, joint angles, muscle activation times and muscle co-contraction index). The purpose of conducting a MANOVA was to have a global assessment of the effects of the independent variables on all dependent variables as a whole. If a statistically significant main effect of age and/or visual conditions were found, subsequent univariate analysis of variances (ANOVAs) were conducted to elucidate the effect of main effect on the dependent measures. Post-hoc comparisons were performed to identify differences in the effects of different levels of the independent variables. All statistical analyses were conducted using JMP 9.0 (SAS Institute, Cary, NC, USA). In order to verify the assumptions of MANOVA and ANOVA, all of the data were evaluated for normality (using Shapiro-Wilk W test), homogeneity of variance (using Hartley F-Max Test), and sphericity (using Bartlett's sphericity test). Logarithmic transformation was used to transform data which were not normally distributed. Non-parametric statistics were used when the values obtained were not normally distributed after logarithmic transformation (Altman, 1991).

## 4.8 Results

### *4.8.1 Required Coefficient of Friction (RCOF) and walking velocity*

To determine if both age groups had similar gait and slipping characteristics during both slip trials, a one-way ANOVA was conducted on gait measures (walking velocity and RCOF at heel-contact). The ANOVA results showed no significant difference of walking velocity and RCOF at between normal walking (NW) and slip trials. The mean and standard deviation of gait

parameters during SWV and SWOV trials between young and old groups are shown in Table 4.4.

Table 4.4 Mean  $\pm$  S.D. of gait parameters during SWV and SWOV trials between young and old groups

Gait Parameter	Young		Old	
	SWV	SWOV	SWV	SWOV
RCOF during NW trial	0.20 $\pm$ 0.03	0.20 $\pm$ 0.02	0.17 $\pm$ 0.02	0.16 $\pm$ 0.02
RCOF during slip trial	0.19 $\pm$ 0.03	0.20 $\pm$ 0.03	0.17 $\pm$ 0.02	0.17 $\pm$ 0.03
Walking velocity during NW trial (m/s)	1.42 $\pm$ 0.15	1.41 $\pm$ 0.13	1.23 $\pm$ 0.13	1.23 $\pm$ 0.15
Walking velocity during slip trial (m/s)	1.46 $\pm$ 0.14	1.47 $\pm$ 0.10	1.28 $\pm$ 0.12	1.24 $\pm$ 0.15

#### 4.8.2 Slip Severity

A mixed-factor MANOVA was conducted between age groups (between-subjects) and visual conditions (within-subject) including slip distance I (SDI), slip distance II (SDII), and slip distance III (SDIII). Logarithmic transformations were used to transform SDI data, which were not normally distributed, before conducting MANOVA test. The MANOVA indicated that slip distance was significantly affected by age groups ( $F_{(3, 54)} = 3.7982, P < 0.0152^*$ ) with Wilks' Lambda ( $P < 0.0194^*$ ).

As such, subsequent univariate ANOVAs were conducted to provide better understanding of how slip distances were influenced by age groups and visual conditions on each dependent variable. Younger adults had significantly longer SDI ( $F_{(1, 56)} = 4.6986, P < 0.0345^*$ ) than older adults, as show in Figure 4.7 (a). Overall, SWOV resulted in increased SDII and SDIII in both age groups. SDII ( $F_{(1, 56)} = 4.2936, P < 0.0429^*$ ) and SDIII ( $F_{(1, 56)} = 4.1064, P < 0.0348^*$ ) during SWOV were significantly longer than those sip distances during SWV, as illustrated in Figure 4.7 (b). MANOVA showed that slide heel velocity (SHV) and peak slide heel velocity (PSHV) were not significantly affected by age groups and visual conditions, as shown in Figure 4.8. Mean and standard deviation of slip parameters during SWV and SWOV trials between young and old groups report in Table 4.5.

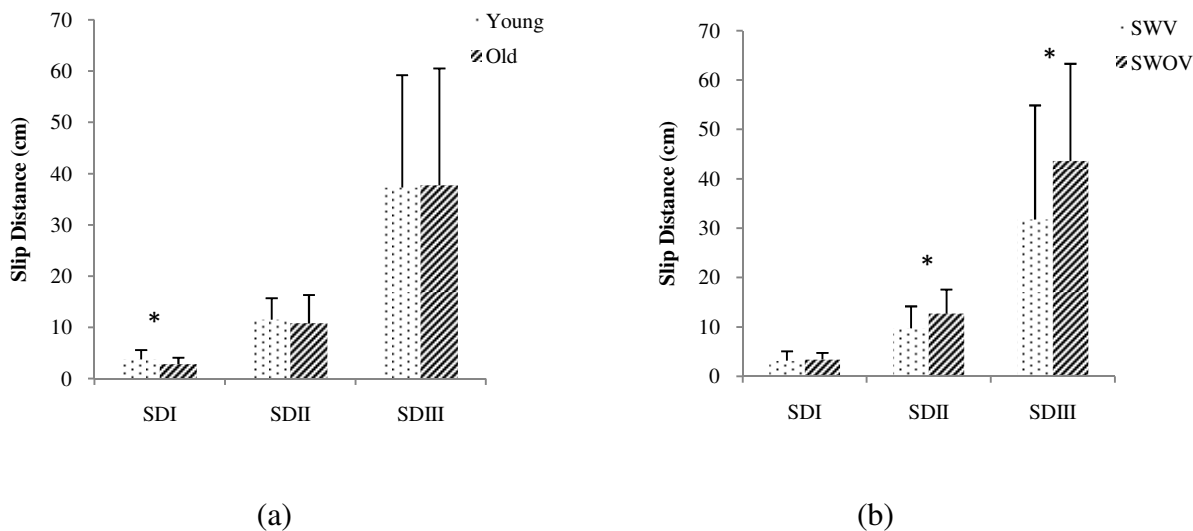

Figure 4.7 Slip distances (SDI, SDII and SDIII) for (a) age groups and (b) visual conditions

(\*  $p < 0.05$ ).

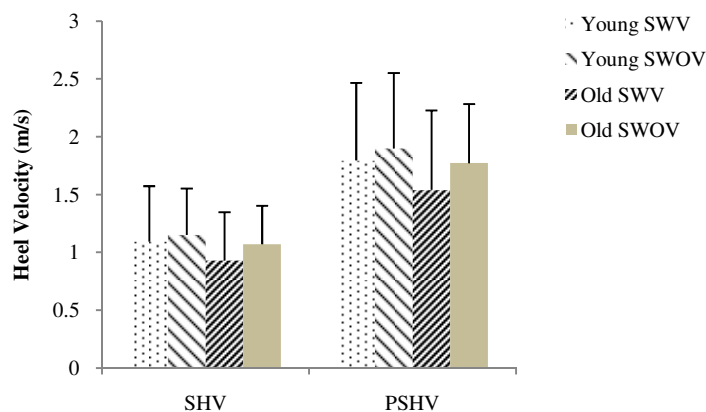

Figure 4.8 Means and standard deviations of SHV and PSHV for Young SWV, Young SWOV, Old SWV, and Old SWOV

In order to provide the relationship between walking velocity and slip severity (SDI, SDII, SDIII, SHV, and PSHV), bivariate correlation analysis was performed. The relationship between walking velocity and SDI indicated that individuals with faster walking velocity had longer SDI (Figure 4.9,  $r = .3331$ ,  $p \approx .0099^*$ ). However, there was no relationship between walking velocity and SDII or SDIII. The relationship between walking velocity and SHV indicated that individuals with faster walking velocity had faster SHV (Figure 4.10,  $r = .3562$ ,  $p$



$\approx .0052^*$ ); and walking velocity and PSHV indicated that individuals with faster walking velocity had higher PSHV (Figure 4.11,  $r = .2644$ ,  $p \approx .0412^*$ ).

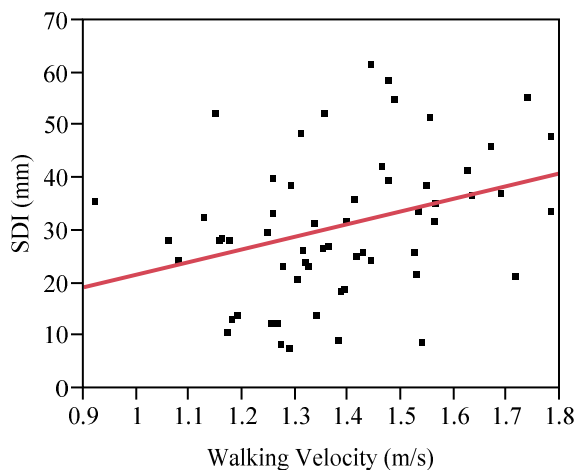

Figure 4.9 Relationship between walking velocity and SDI of each participant ( $r = .3331$ ).

In general, individuals with higher walking velocity slipped farther.

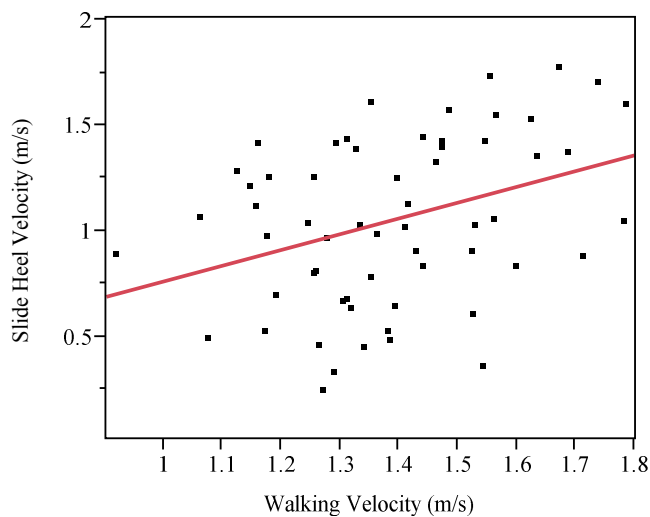

Figure 4.10 Relationship between walking velocity and SHV of each participant ( $r = .3562$ ).

In general, individuals with higher walking velocity have faster slip heel velocity.

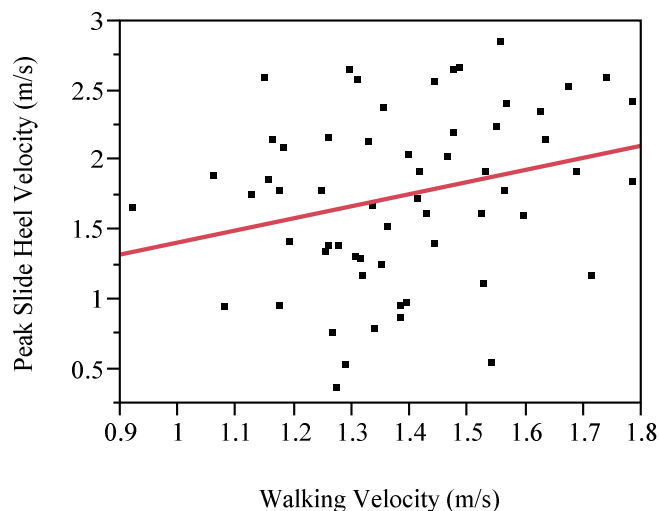

Figure 4.11 Relationship between walking velocity and PSHV of each participant ( $r = .2644$ ).

In general, individuals with higher walking velocity have faster peak slip heel velocity.

Table 4.5 Mean  $\pm$  S.D. of slip parameters during SWV and SWOV trials between young and old groups

Slip severity	Young		Old	
	SWV	SWOV	SWV	SWOV
Slip distance I (cm)	3.88 $\pm$ 2.16	3.403 $\pm$ 1.42	2.40 $\pm$ 1.10	3.10 $\pm$ 1.28
Slip distance II (cm)	10.54 $\pm$ 3.69	11.39 $\pm$ 4.09	9.40 $\pm$ 5.00	13.73 $\pm$ 6.19
Slip distance III (cm)	32.05 $\pm$ 18.35	38.35 $\pm$ 21.22	29.39 $\pm$ 22.16	45.39 $\pm$ 18.27
Slide heel velocity (m/s)	1.05 $\pm$ 0.46	1.14 $\pm$ 0.39	0.92 $\pm$ 0.41	1.08 $\pm$ 0.32
Peak slide heel velocity (m/s)	1.78 $\pm$ 0.66	1.88 $\pm$ 0.63	1.53 $\pm$ 0.68	1.79 $\pm$ 0.50

### 4.8.3 Response Time associated with Slip Events

#### Perturbed foot response time measures

A mixed-factor MANOVA was conducted between age groups (between-subjects) and visual conditions (within-subject) including slip-start, slip-middle, slip-peak and slip-stop. The MANOVA indicated that perturbed foot response time was significantly affected by age groups ( $F_{(4, 53)} = 3.3458, P < 0.0163^*$ ) with Wilks' Lambda ( $P < 0.0332$ ). Univariate ANOVA was

conducted to follow up MANOVA to provide better understanding of how perturbed foot response times were influenced by age groups and visual conditions on each dependent variable.

Overall, slip without visual input resulted in delaying slip-stop time; and young adults were able to stop slip faster than older adults. There was statistically ( $F_{(1, 56)} = 4.2723, P < 0.0434^*$ ) of age effects and ( $F_{(1, 56)} = 4.8748, P < 0.0314^*$ ) of visual condition effects on slip-stop time, as illustrated in Figure 4.12 (a) and (b), respectively. The means and standard deviations of slip-start, slip-middle, slip-peak, and slip-stop for the four groups (Young SWV, Young SWOV, Old SWV, and Old SWOV) are listed in Table 4.6. Figure 4.13 indicates the example of (a) heel velocity and (b) heel acceleration associated with slip-start, slip-middle, slip-peak and slip-stop of perturbed foot during SWV (solid line) and SWOV (dashed line), respectively.

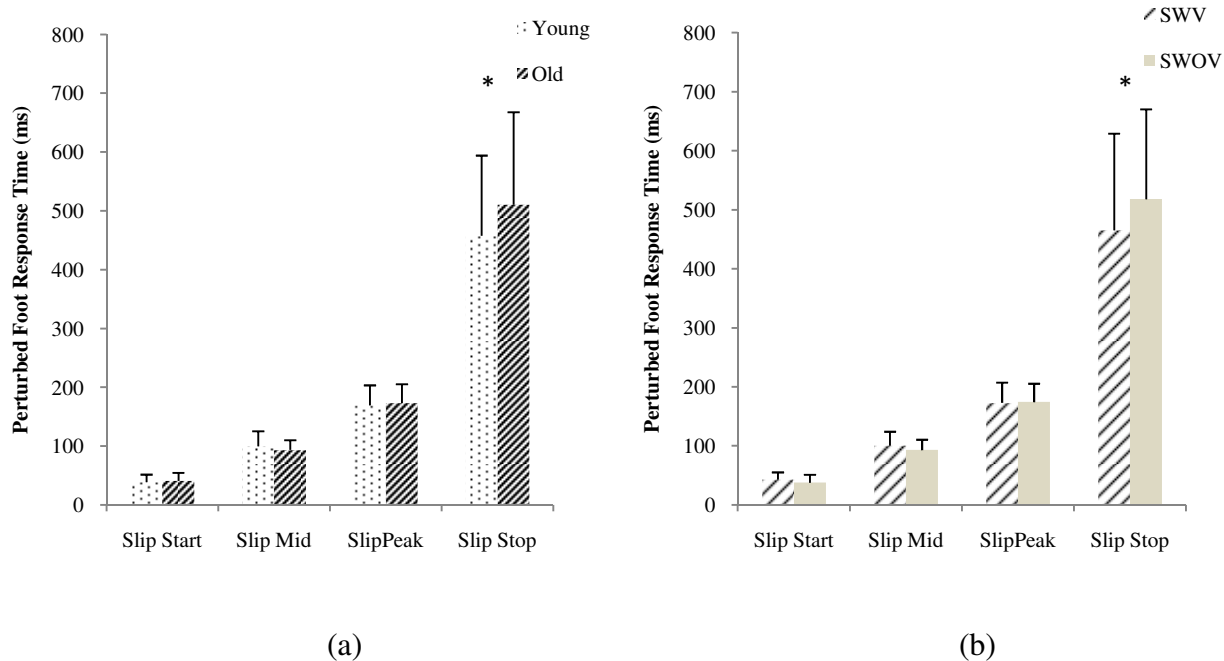
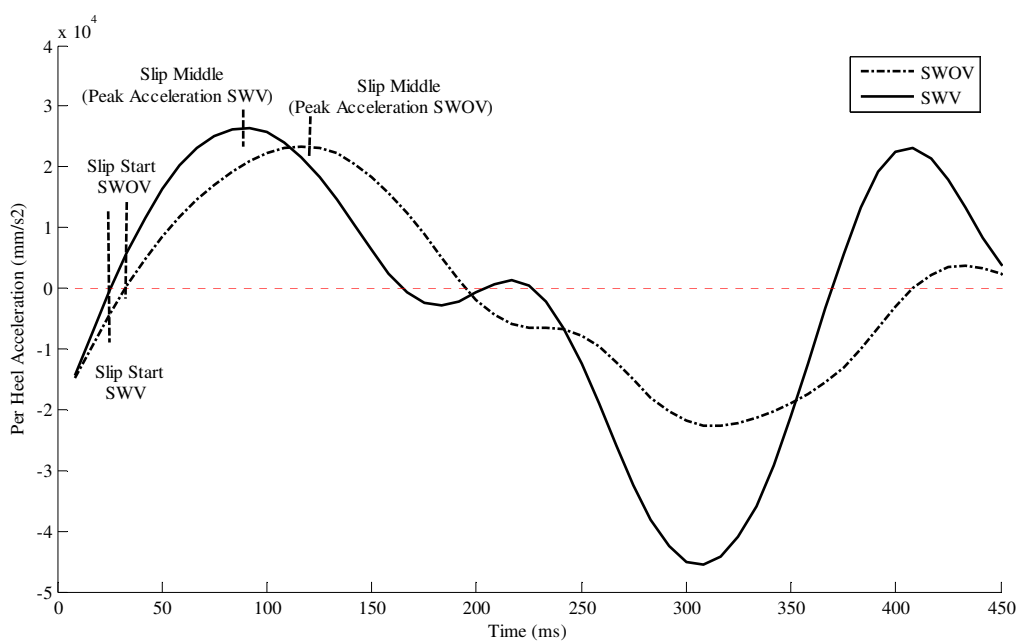

Figure 4.12 Perturbed foot response time (slip-start, slip-middle, slip-peak and slip-stop) for (a) between age groups and (b) between visual conditions (\*  $p < 0.05$ ).

Table 4.6 Mean  $\pm$  S.D. of perturbed foot response time during SWV and SWOV trials between age groups

Perturbed Foot Response Time	Young		Old	
	SWV	SWOV	SWV	SWOV
Slip-start (ms)	40.55 $\pm$ 12.94	37.50 $\pm$ 12.55	45.55 $\pm$ 12.55	37.78 $\pm$ 15.06
Slip-middle (ms)	105.56 $\pm$ 30.48	93.45 $\pm$ 18.83	95.55 $\pm$ 13.68	92.78 $\pm$ 20.62
Slip-peak(ms)	176.11 $\pm$ 42.94	163.33 $\pm$ 18.22	170.00 $\pm$ 31.94	185.00 $\pm$ 36.62
Slip-stop (ms)	445.00 $\pm$ 147.89	472.78 $\pm$ 102.81	467.77 $\pm$ 173.31	596.67 $\pm$ 114.21



(a)

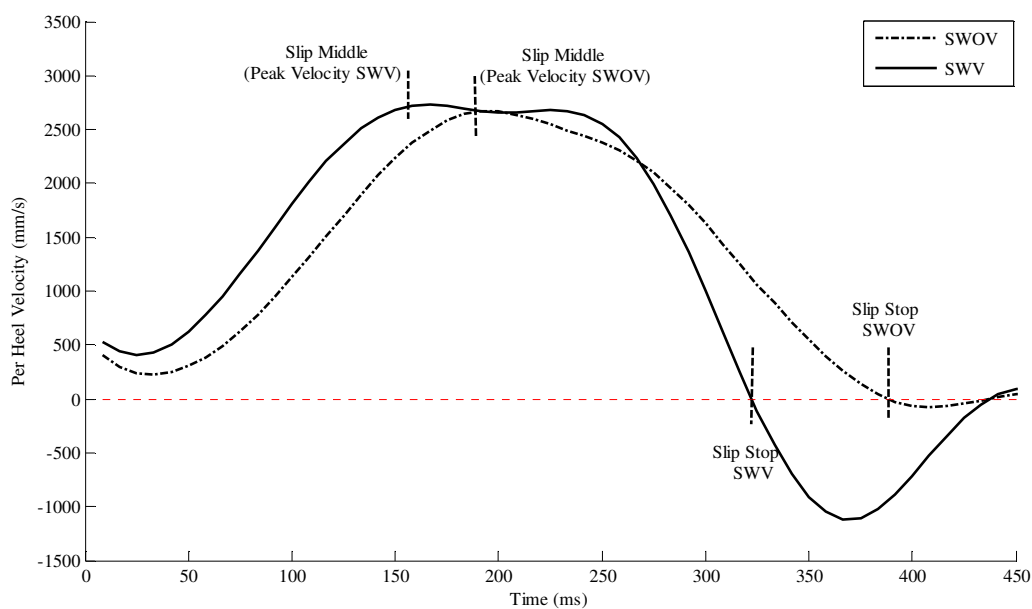

(b)

Figure 4.13 Example of perturbed (a) heel acceleration and (b) heel velocity during SWV (solid line) and SWOV (dotted line)

#### Unperturbed foot response time measures

A mixed-factor MANOVA was conducted between age groups (between-subjects) and visual conditions (within-subject) including toe-off, foot-onset, and foot-down. The MANOVA indicated that unperturbed foot response time was significantly affected by age ( $F_{(3, 50)} = 7.8780$ ,  $P < 0.0002^*$ ) with Wilks' Lambda ( $P < 0.0022^*$ ). A follow-up univariate ANOVA was conducted to provide better understanding of how unperturbed foot response times were influenced by age groups and visual conditions on each dependent variable.

The results associated with toe-off ( $F_{(1, 52)} = 17.3380$ ,  $P < 0.0001^*$ ), foot-onset ( $F_{(1, 52)} = 15.4199$ ,  $P < 0.0003^*$ ) and foot-down ( $F_{(1, 52)} = 20.3978$ ,  $P < 0.0001^*$ ) in between age groups showed significant differences. The means and standard deviations of slip toe-off, foot-onset, and foot-down for two age groups (younger and older adults) are illustrated in Figure 4.14 (a). The means and standard deviations of slip toe-off, foot-onset, and foot offset for the four groups (Young SWV, Young SWOV, Old SWV, and Old SWOV) are illustrated in Figure 4.14 (b) and listed in Table 4.7. Overall, SWOV caused delayed unperturbed foot response time in older

groups. In contrast, younger groups had early foot-onset and foot-down during SWOV. However, there were no statistically significant different unperturbed foot response time between SWV and SWOV. Figure 4.15 indicates the example of unperturbed (a) toe position and (b) velocity associated with toe-off, foot-onset, and foot-down during SWV (solid line) and SWOV (dotted line), respectively.

Table 4.7 Mean  $\pm$  S.D. of unperturbed foot response time during SWV and SWOV trials between age groups

Unperturbed Foot Response Time	Young		Old	
	SWV	SWOV	SWV	SWOV
Toe-off (ms)	116.67 $\pm$ 30.69	117.86 $\pm$ 25.91	141.07 $\pm$ 36.90	162.18 $\pm$ 38.58
Foot-onset (ms)	173.89 $\pm$ 46.81	160.12 $\pm$ 23.38	197.62 $\pm$ 42.79	217.31 $\pm$ 41.17
Foot-down (ms)	237.22 $\pm$ 32.25	227.38 $\pm$ 34.81	284.52 $\pm$ 58.46	291.67 $\pm$ 50.35

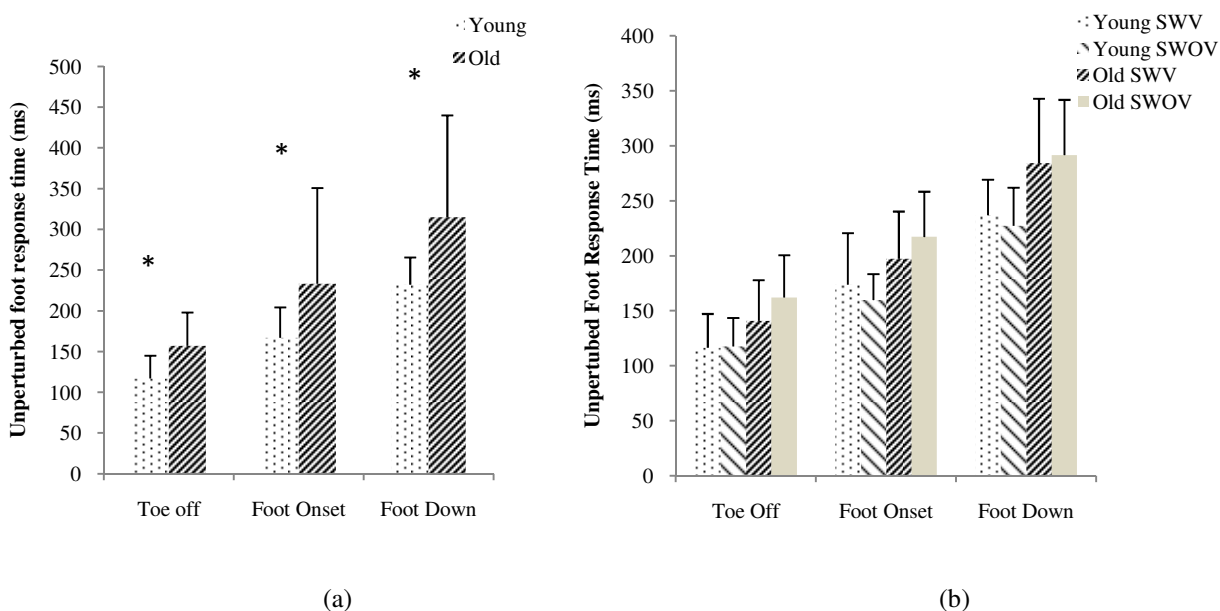
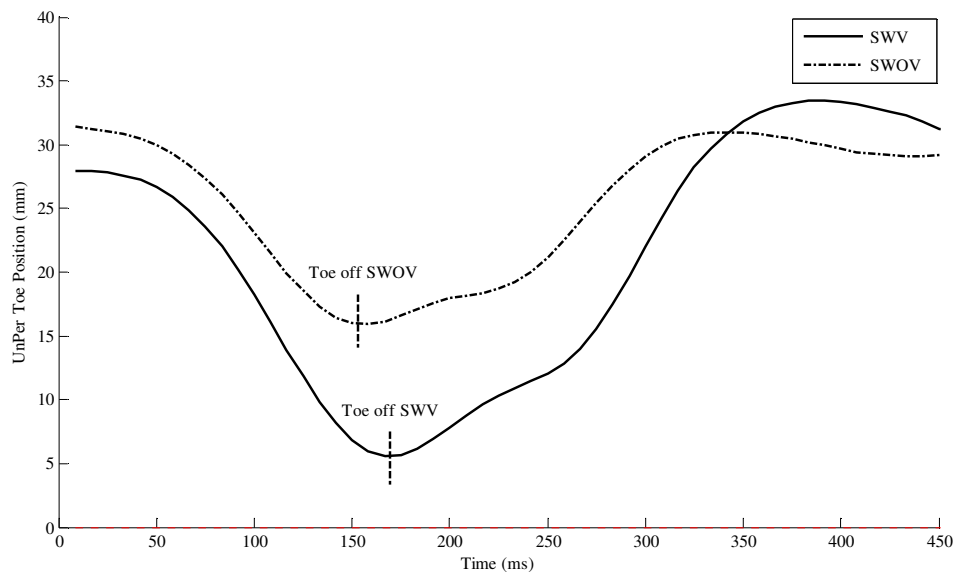
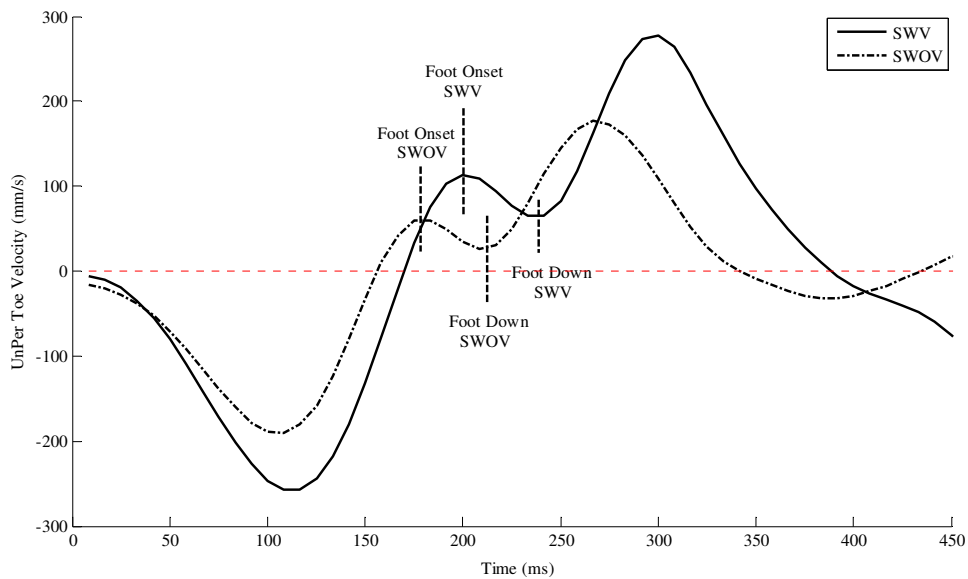

Figure 4.14 Unperturbed foot response time (slip toe-off, foot-onset, and foot-down) (a) for younger and older groups (\*  $p < 0.05$ ) and (b) for four groups (Young SWV, Young SWOV, Old SWV, and Old SWOV)



(a)



(b)

Figure 4.15 Example unperturbed (a) toe position and (b) toe velocity during SWV (solid line) and SWOV (dotted line)

*Perturbed and unperturbed arm response time measures*

A mix-factor MANOVA was conducted between age groups (between-subjects) and visual conditions (within-subject) including perturbed arm-onset, perturbed arm-offset, unperturbed arm-onset, and unperturbed arm-offset. Overall, younger adults swung their arms during slip either with or without visual input. In contrast, several older adults did not swing their arms during slip. There were three older adults who dropped (not swing) their perturbed arms during slip with visual input. During slip without visual input, five older adults dropped their perturbed arms. Moreover, among those five elderly, one of them also dropped his/her unperturbed arm. Thus in this session, data from participants who did not swing their arms were excluded to reduce high variability of arm response time.

The MANOVA indicated that arm response time was not significantly affected by age groups and visual conditions. Although MANOVA showed no significant difference on arm response times, the small p-value of visual conditions ( $P < 0.1032$ ) indicated the potential effect of visual inputs on arm reaction. In young adults, perturbed arm-onset time during SWV was closed to the perturbed arm-onset during SWOV. In contrast, older groups had earlier perturbed arm-onset during SWOV than the onset during SWV. The early onset of perturbed arm might occur from losing control of the arm during SWOV. For unperturbed arm, an early onset and offset were observed in both age groups. The means and standard deviations of perturbed arm-onset, perturbed arm-offset, unperturbed arm-onset, and unperturbed arm-offset for the four conditions (Young SWV, Young SWOV, Old SWV, and Old SWOV) are listed in Table 4.8 and illustrated in Figure 4.16. Figure 4.17 indicates the example of (a) time to peak jerk (as arm-onset) and (b) time to zero velocity (as arm-offset) of perturbed arm SWV, unperturbed arm SWV, unperturbed arm SWOV, and unperturbed arm SWOV.



Table 4.8 Mean  $\pm$  S.D. of unperturbed foot response time during SWV and SWOV trials between age groups

Arm response time (ms)	Young		Old	
	SWV	SWOV	SWV	SWOV
Per arm-onset	201.92 $\pm$ 35.87	204.76 $\pm$ 39.73	245.83 $\pm$ 67.65	190.00 $\pm$ 29.08
Pert arm-offset	486.54 $\pm$ 140.00	558.33 $\pm$ 171.35	561.80 $\pm$ 175.75	499.99 $\pm$ 261.55
Unper arm-onset	229.17 $\pm$ 52.68	213.10 $\pm$ 32.47	232.78 $\pm$ 32.96	223.81 $\pm$ 42.85
Unper arm-offset	572.02 $\pm$ 105.70	551.19 $\pm$ 79.25	571.67 $\pm$ 104.31	522.62 $\pm$ 111.35

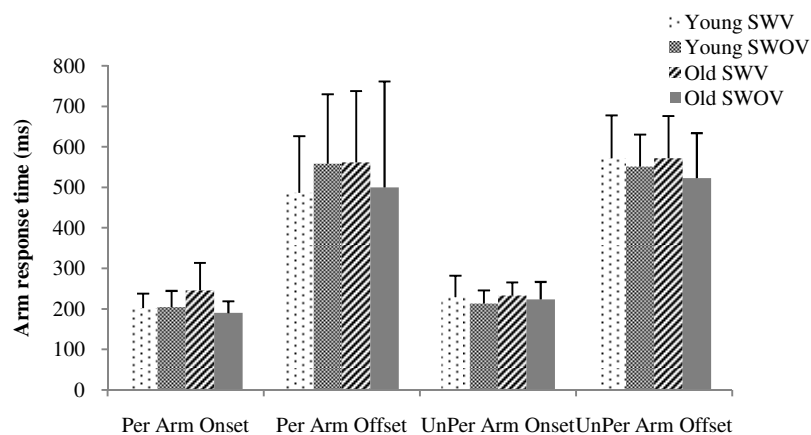
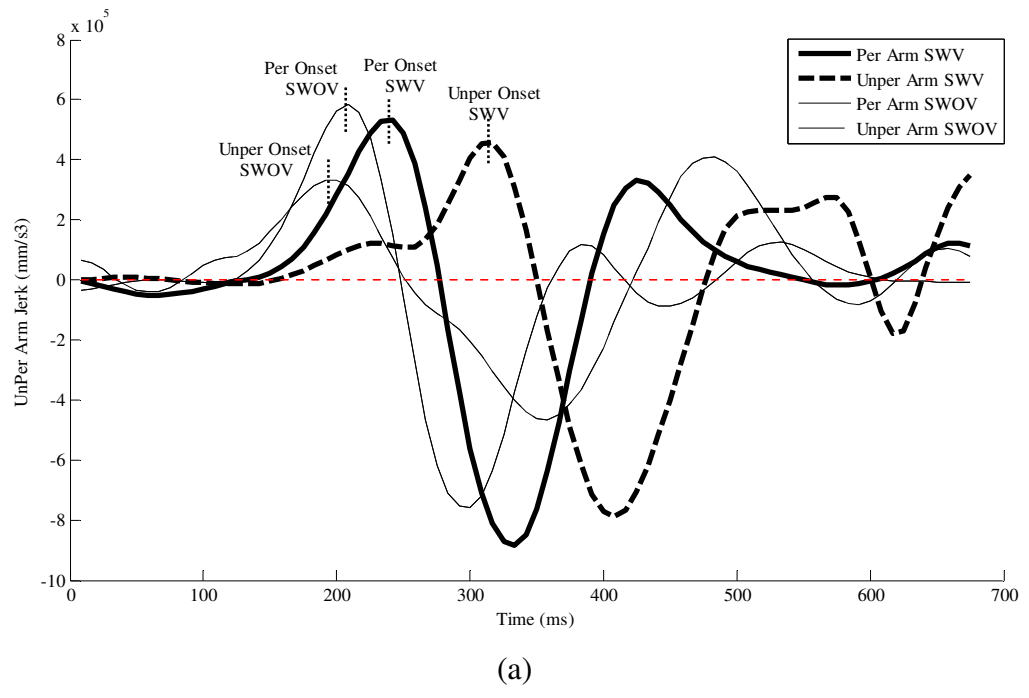
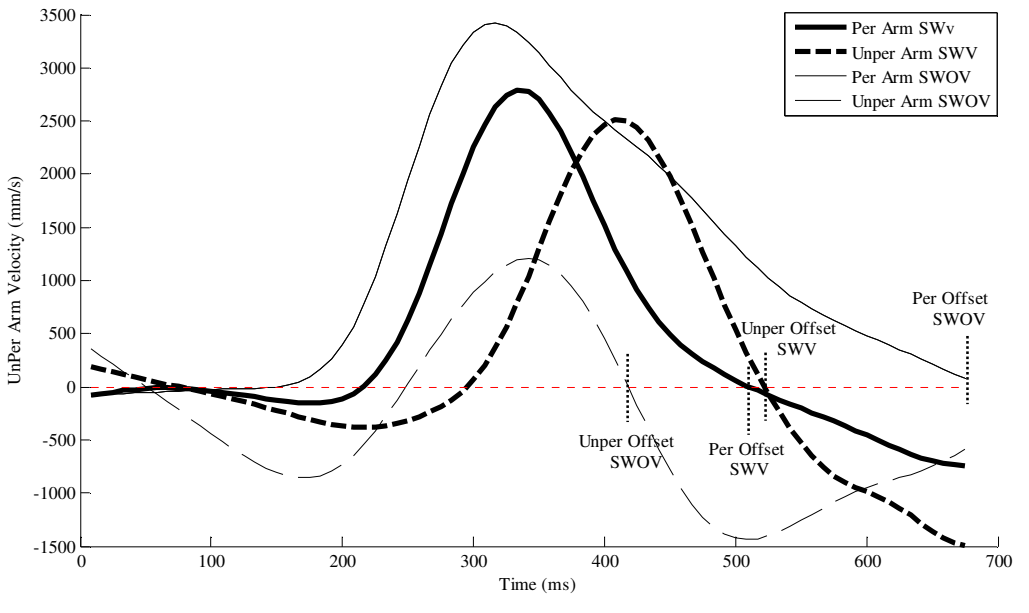

Figure 4.16 Means and standard deviations of arm response time for Young SWV, Young SWOV, Old SWV, and Old SWOV



(a)



(b)

Figure 4.17 Example of (a) jerk and (b) velocity of perturbed arm and unperturbed arm (perturbed arm SWV (thick solid line), unperturbed arm SWV (thick dotted line), unperturbed arm SWOV (thin solid line) and unperturbed arm SWOV (thin dotted line)) during unexpected slip perturbation

#### 4.8.4 Postural Adjustments

There are four groups of variables in this session including 1) ankle, knee, hip, trunk, perturbed and unperturbed shoulder angles at heel-contact, 2) peak ankle, knee, hip, and trunk angles during slip, 3) peak perturbed and unperturbed shoulder angles during slip, and 4) peak ankle, knee, hip, trunk, perturbed and unperturbed shoulder angular velocity during slip. Two-ways MANOVA between age groups (between-subjects) and visual conditions (within-subject) was performed with each dependent variable group. For the first group of dependent variables, an initial MANOVA indicated no significant differences with ankle, knee, hip, trunk, perturbed and unperturbed shoulder angles at heel-contact in both age groups.

Before conducting MANOVA with the second group of dependent variables, a logarithmic transformation was used to transform peak hip flexion angle which were not normally distributed. The MANOVA results showed that peak joint angles during slipping were significantly affected by visual conditions ( $F_{(4, 49)} = 2.8328, P < 0.0334^*$ ) with Wilks' Lambda ( $P < 0.0418^*$ ). Then a follow-up univariate ANOVA was conducted to provide better understanding of how peak joint angles were influenced by age groups and visual conditions on each dependent variable. Older adults had significantly larger ankle peak plantarflexion ( $F_{(1, 52)} = 5.0887, P < 0.0283^*$ ) and peak hip flexion ( $F_{(1, 52)} = 6.1644, P < 0.0163^*$ ) than their younger counterparts, as shown in Figure 4.18 (a). The results also showed significantly larger peak knee flexion ( $F_{(1, 52)} = 4.7651, P < 0.0336^*$ ) and peak hip flexion ( $F_{(1, 52)} = 9.3091, P < 0.0036^*$ ) during SWOV than those angle during SWV, as shown in Figure 4.18 (b). Moreover, ANOVA showed interaction between age groups and visual conditions on peak hip flexion ( $F_{(1, 52)} = 3.0379, P < 0.0873^\dagger$ ) at  $\alpha = 0.1$ . Figure 4.19 illustrates mean plot of peak hip flexion between age groups (Young vs. Old) and visual conditions (SWOV vs. SWV). Tukey pair-wise comparisons of means were performed to identify differences on peak hip flexion. Peak hip flexion of old SWOV was significantly different from other groups, as shown in Figure 4.20.

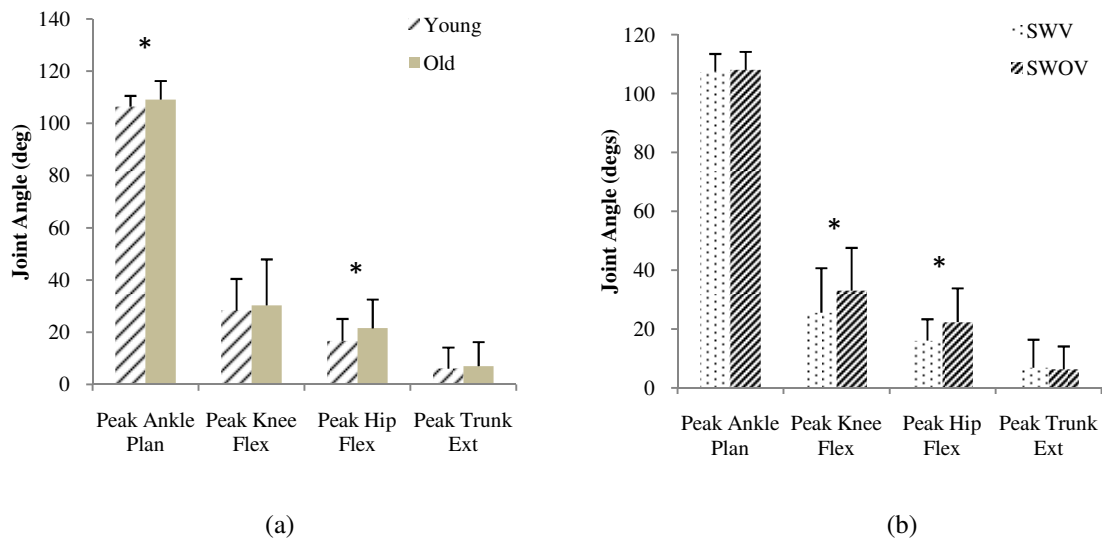

Figure 4.18 Peak joint angles (ankle, knee, hip, and trunk) (a) for younger and older groups and (b) for visual condition (\*  $p < 0.05$ )

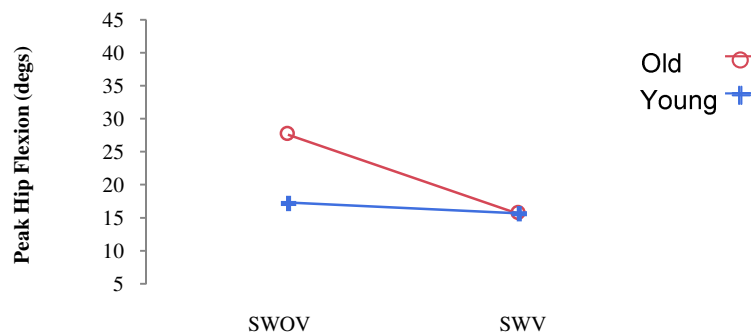

Figure 4.19 Mean plot of peak hip flexion between age groups (Young vs. Old) and visual conditions (SWOV vs. SWV)

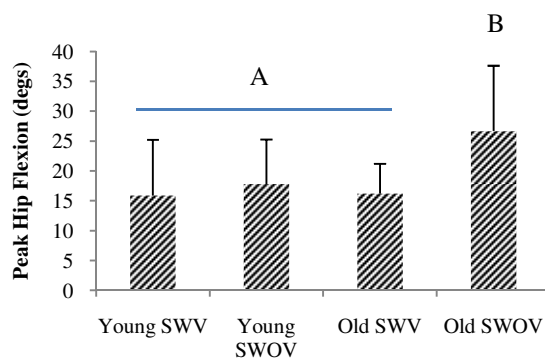

Figure 4.20 Mean and S.D. of peak hip flexion between four conditions (Young SWV, Young SWOV, Old SWV, and Old SWOV)

For peak shoulder flexion, the MANOVA indicated no significant effects on perturbed and unperturbed shoulder angles by age or visual conditions. MANOVA testing also indicated no significant effects of age and visual conditions on joint angular velocity. Although the differences of angular velocity between age groups and visual conditions were not significant, joint angular velocity during SWOV was faster than angular velocity during SWV as shown in Figure 4.21 (a). Younger adults had faster shoulder angular velocity on both sides than their older counterparts, as shown in Figure 4.21(b).

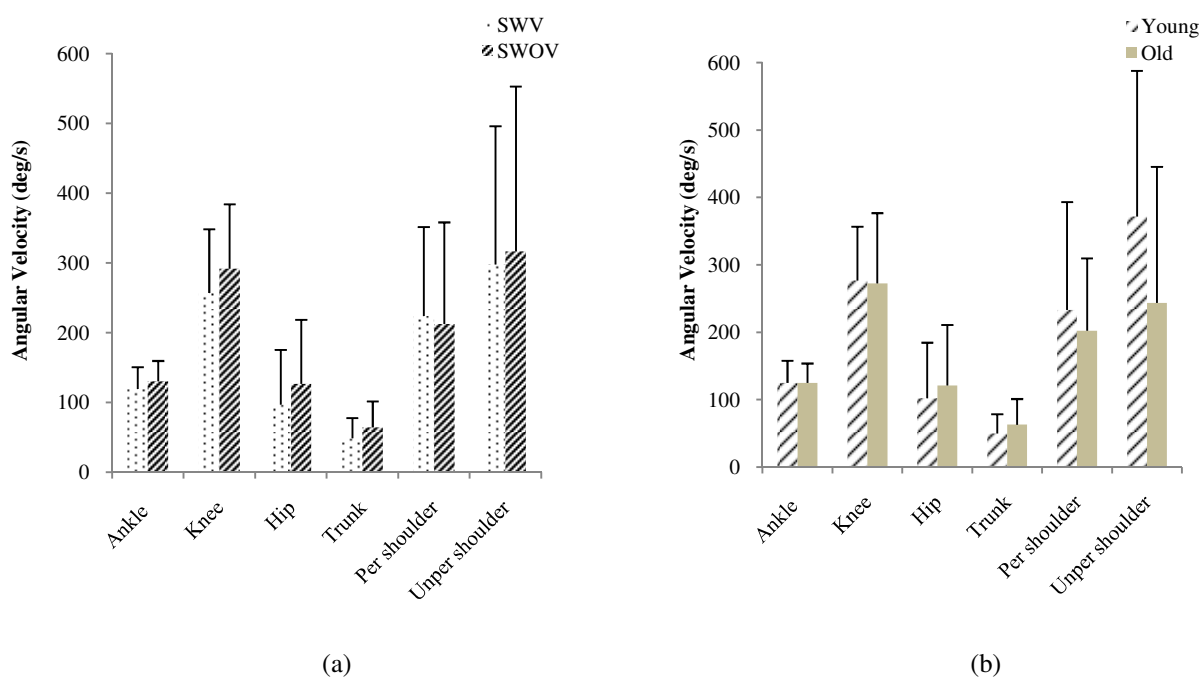

Figure 4.21 Joint angular velocities during slip with (a) SWV vs. SWOV and (b) Young vs. Old

The means and standard deviations of joint angles and angular velocities for the four groups (Young SWV, Young SWOV, Old SWV, and Old SWOV) are listed in Table 4.9. Figure 4.22 shows the example of joint angles during slip with visual input (SWV) (solid line) and slip without visual input (SWOV) (dashed line).

Table 4.9 Mean  $\pm$  S.D. of joint angles and angular velocities during SWV and SWOV between younger and older groups

Variables	Young		Old	
	SWV	SWOV	SWV	SWOV
<b>Joint angles (degs)</b>				
Ankle angle at HC (+ = plantar)	96.69 $\pm$ 2.30	96.25 $\pm$ 2.54	95.44 $\pm$ 3.00	95.54 $\pm$ 2.69
Knee angle at HC (+ = flex)	-4.32 $\pm$ 2.55	-3.68 $\pm$ 1.42	-4.63 $\pm$ 1.46	-3.33 $\pm$ 1.97
Hip angle at HC (+ = flex)	10.00 $\pm$ 4.79	9.11 $\pm$ 5.27	12.40 $\pm$ 2.76	11.23 $\pm$ 2.52
Trunk angle at HC (+ = flex)	4.92 $\pm$ 1.70	4.14 $\pm$ 2.85	6.11 $\pm$ 2.47	5.47 $\pm$ 2.41
Per shoulder angle (+ = flex)	-31.14 $\pm$ 5.78	-28.39 $\pm$ 7.31	-24.48 $\pm$ 12.71	-27.42 $\pm$ 9.78
Unper shoulder angle (+ = flex)	9.18 $\pm$ 9.64	7.76 $\pm$ 13.22	11.77 $\pm$ 10.72	7.03 $\pm$ 9.69
<b>Peak joint angles (degs)</b>				
Peak Ankle angle (+ = plantar)	106.16 $\pm$ 4.15	106.62 $\pm$ 4.27	108.59 $\pm$ 7.40	109.58 $\pm$ 7.17
Peak Knee angle (+ = flex)	24.41 $\pm$ 10.98	32.18 $\pm$ 12.43	26.77 $\pm$ 18.41	33.90 $\pm$ 16.63
Peak Hip angle (+ = flex)	15.94 $\pm$ 9.33	17.57 $\pm$ 7.63	16.23 $\pm$ 4.98	26.92 $\pm$ 12.74
Peak Trunk angle (+ = flex)	-5.56 $\pm$ 7.87	-6.67 $\pm$ 8.57	-8.08 $\pm$ 10.98	-6.07 $\pm$ 7.16
Peak Per shoulder angle (+ = flex)	3.28 $\pm$ 46.57	11.98 $\pm$ 39.42	4.32 $\pm$ 25.84	0.70 $\pm$ 41.99
Peak Un shoulder angle (+ = flex)	59.93 $\pm$ 50.48	63.98 $\pm$ 69.38	33.12 $\pm$ 75.70	32.01 $\pm$ 75.55
<b>Joint angular velocity (deg/s)</b>				
Peak Ankle velocity	125.72 $\pm$ 32.11	124.26 $\pm$ 34.23	113.76 $\pm$ 29.72	136.07 $\pm$ 23.29
Peak Knee velocity	251.46 $\pm$ 54.66	301.64 $\pm$ 94.79	261.85 $\pm$ 117.80	282.70 $\pm$ 92.20
Peak Hip velocity	88.17 $\pm$ 65.95	115.75 $\pm$ 96.67	104.93 $\pm$ 90.44	136.65 $\pm$ 89.30
Peak Trunk velocity	47.80 $\pm$ 25.63	51.91 $\pm$ 31.50	49.33 $\pm$ 32.67	76.27 $\pm$ 39.20
Peak Per shoulder velocity	234.18 $\pm$ 161.26	231.82 $\pm$ 165.50	212.34 $\pm$ 76.98	194.93 $\pm$ 127.31
Peak Unper shoulder velocity	335.35 $\pm$ 177.74	387.89 $\pm$ 255.61	217.72 $\pm$ 209.20	250.23 $\pm$ 204.42

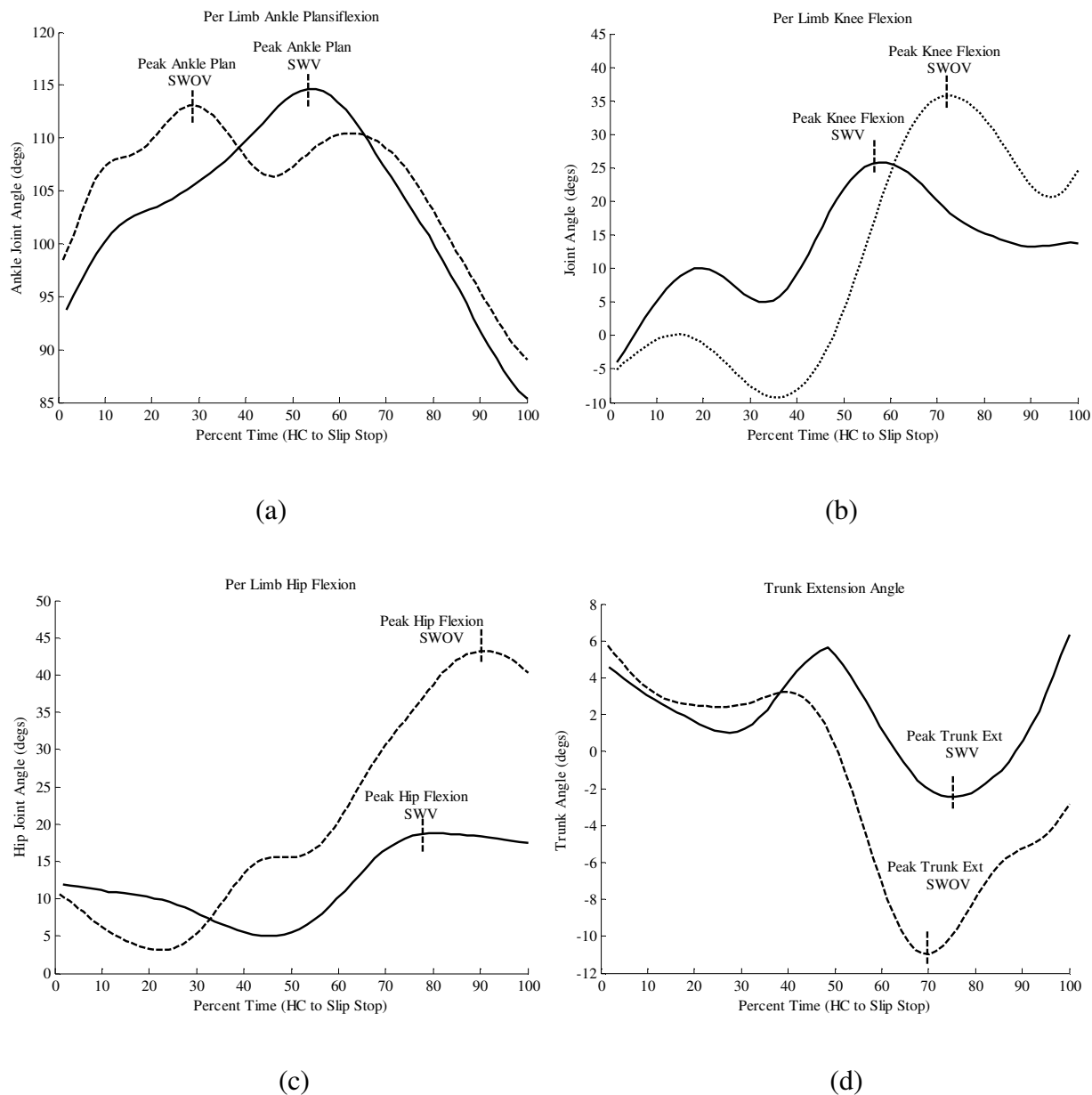

Figure 4.22 Example of (a) ankle, (b) knee, (c) hip and (d) trunk joint angle during slip with visual input (SWV) (solid line) and slip without visual input (SWOV) (dashed line)

#### 4.8.5 EMG Muscle Activation Patterns

##### Muscle Activation Onset

A mixed-factor MANOVA was conducted between age groups (between-subjects) and visual conditions (within-subject) including muscle activation onset of four muscle groups

(medial gastrocnemius (MG), tibialis anterior (TA), medial hamstrings (MH) and vastus lateralis (VL)). Logarithmic transformation was used to transform MG, TA, MH and VL onset data which were not normally distributed before conducting MANOVA test. The MANOVA indicated that muscle activation onset was significantly affected by age ( $F_{(4, 48)} = 3.3277$ ,  $P < 0.0175^*$ ) with Wilks' Lambda ( $P < 0.0294^*$ ).

A follow-up univariate ANOVA was conducted to provide better understanding of how muscle activation onset was influenced by age groups and visual conditions. In general, older adults demonstrated a slower muscle activation onset than younger adults in four muscle groups, as shown in Figure 4.23 (a). ANOVA results showed significant differences in that older participants have slower onset of MH ( $F_{(1, 51)} = 5.8948$ ,  $P < 0.0188^*$ ) and onset of VL ( $F_{(1, 51)} = 6.4111$ ,  $P < 0.0145^*$ ) than their younger counterparts. The delay onset of MG and TA muscles were also observed in the older group, but the differences between the groups were not significant. An early TA onset was also observed during SWOV in both age groups. This effect was statistically significant ( $F_{(1, 51)} = 6.3091$ ,  $P < 0.0152^*$ ), as illustrated in Figure 4.23 (b). An early onset of MG, MH, and VL muscles were also observed during SWOV, but the differences between the visual conditions were not significant.

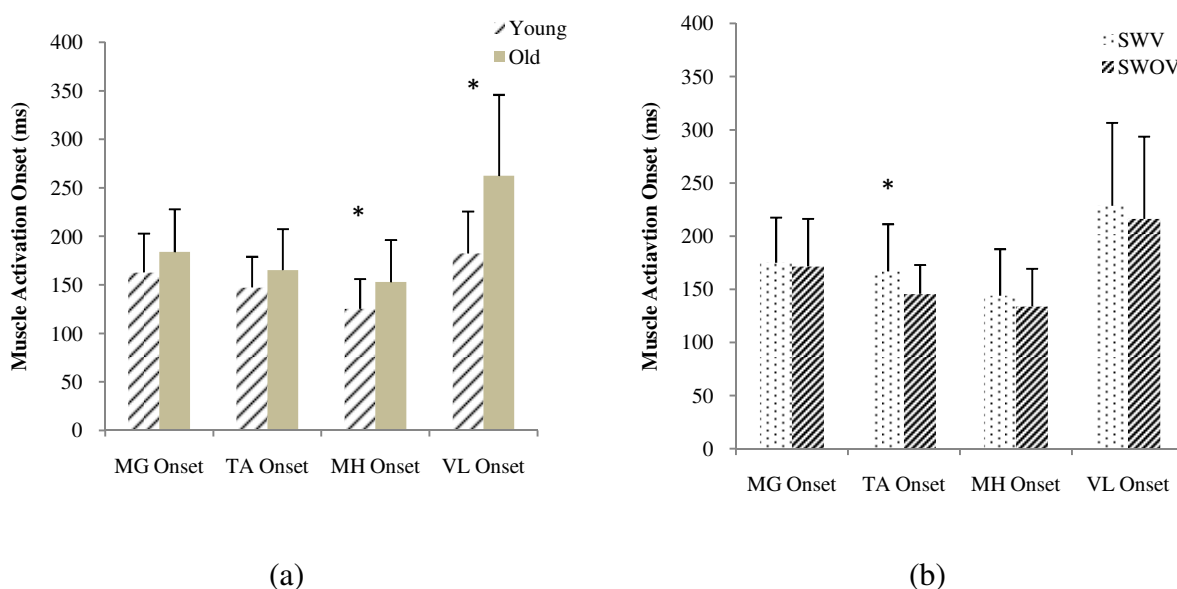

Figure 4.23 Muscle activation onset (a) between Young vs. Old and (b) during slip with visual input (SWV) and slip without visual input (SWOV) (\*  $p < 0.05$ )



### Duration of Muscle Activity

A mixed-factor MANOVA was conducted between age groups (between-subjects) and visual conditions (within-subject) including duration of four muscle activities (medial gastrocnemius (MG), tibialis anterior (TA), medial hamstrings (MH) and vastus lateralis (VL)). Logarithmic transformation was used to transform MG and TA duration data which were not normally distributed before conducting MANOVA test. The MANOVA indicated that muscle activity duration was significantly affected\* by age ( $F_{(4, 51)} = 18.9862, P < 0.0001^*$ ) and by visual conditions ( $F_{(4, 51)} = 2.6627, P < 0.0429^*$ ) with Wilks' Lambda ( $P < 0.0001^*$ ).

A follow-up univariate ANOVA was conducted to provide better understanding of how duration of muscle activity was influenced by age groups and visual conditions. In general, older adults demonstrated longer duration of muscle activity than the younger adults, as shown in Figure 4.24 (a). ANOVA results showed significant differences that the older participants have longer duration of MG ( $F_{(1, 54)} = 70.4561, P < 0.0001^*$ ) and longer duration of TA ( $F_{(1, 54)} = 5.2073, P < 0.0265^*$ ) than their younger counterparts. Duration of muscle activity was also longer during SWOV in both age groups. However, the follow-up indicated duration of MH during SWOV was longer duration ( $F_{(1, 54)} = 6.6453, P < 0.0127^*$ ), as illustrated in Figure 4.24 (b). Duration of MG, TA, and VL muscles were also longer during SWOV, but the differences between the visual conditions were not significant.

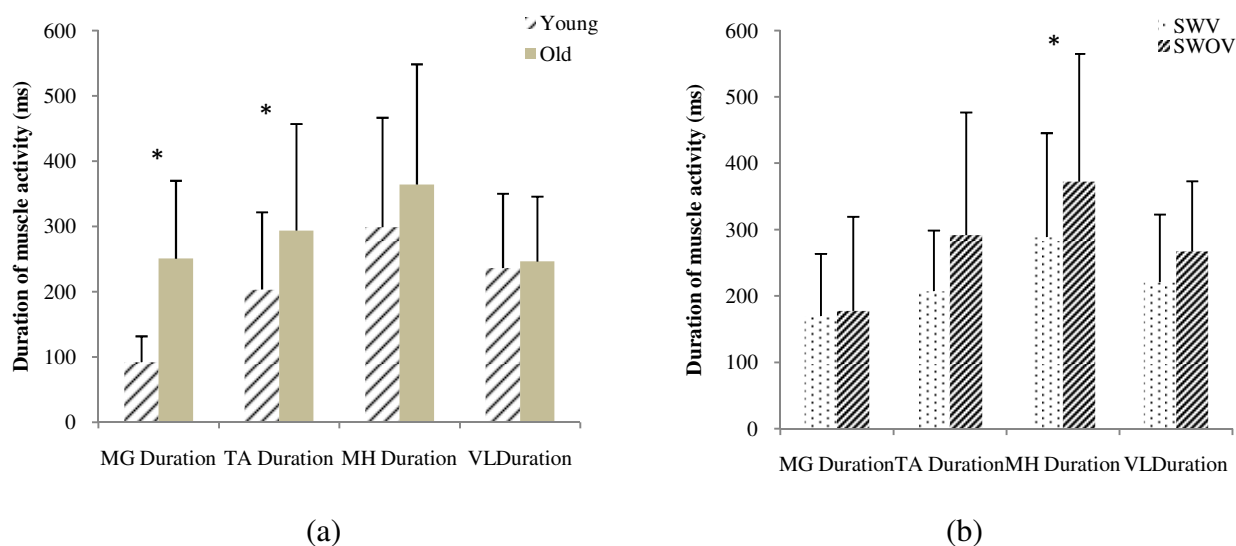

Figure 4.24 Duration of muscle activity (a) between Young vs. Old and (b) during slip with visual input (SWV) and slip without visual input (SWOV) (\*  $p < 0.05$ ).

The means and standard deviations of onset and duration of muscle activity for the four groups (Young SWV, Young SWOV, Old SWV, and Old SWOV) are listed in Table 4.10. Figure 4.25 shows the example of EMG activity (onset and offset) during slip with visual input (SWV) and slip without visual input (SWOV).

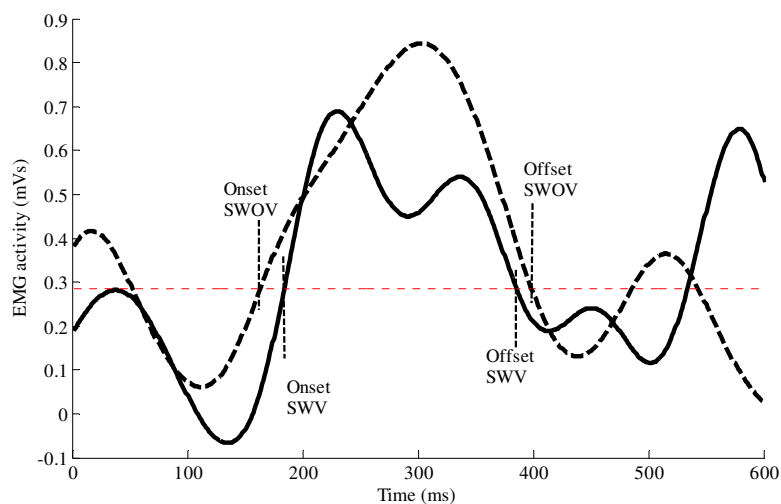

Figure 4.25 Example of EMG activities (onset and offset) during slip with visual input (SWV) and slip without visual input

Table 4.10 Mean  $\pm$  S.D. of onset and duration of muscle activity during SWV and SWOV between younger and older groups

Variables	Young		Old	
	SWV	SWOV	SWV	SWOV
<b>Medial Gastrocnemius (MG)</b>				
Onset (ms)	158.17 $\pm$ 37.06	167.68 $\pm$ 39.61	184.67 $\pm$ 42.25	173.27 $\pm$ 49.03
Duration (ms)	92.17 $\pm$ 39.90	92.50 $\pm$ 40.36	74.40 $\pm$ 74.40	262.98 $\pm$ 156.26
<b>Tibialis Anterior (TA)</b>				
Onset (ms)	153.89 $\pm$ 39.61	142.68 $\pm$ 19.25	179.45 $\pm$ 43.63	149.52 $\pm$ 30.80
Duration (ms)	182.89 $\pm$ 100.24	225.18 $\pm$ 135.54	232.56 $\pm$ 73.09	358.81 $\pm$ 207.12
<b>Medial Hamstrings (MH)</b>				
Onset (ms)	129.17 $\pm$ 31.35	121.85 $\pm$ 29.36	156.74 $\pm$ 48.52	146.37 $\pm$ 37.53
Duration (ms)	263.44 $\pm$ 139.75	334.89 $\pm$ 189.07	317.70 $\pm$ 167.69	410.61 $\pm$ 193.90
<b>Vastus Lateralis (VL)</b>				
Onset (ms)	196.72 $\pm$ 55.05	211.37 $\pm$ 90.80	269.00 $\pm$ 84.93	254.88 $\pm$ 81.46
Duration (ms)	197.11 $\pm$ 108.81	278.87 $\pm$ 106.66	237.67 $\pm$ 94.17	255.83 $\pm$ 107.42

### Muscle Co-Contraction

An initial MANOVA was performed between age groups (between-subjects) and visual conditions (within-subject) with muscle co-contraction at the knee (CCI Knee) and ankle (CCI Ankle) joints during slipping. Logarithmic transformations were used to transform CCI Knee and CCI Ankle data which were not normally distributed before conducting the MANOVA tests. The MANOVA tests indicated that muscle co-contraction was significantly affected by age ( $F_{(2, 52)} = 5.5781, P < 0.0064^*$ ) and by visual conditions ( $F_{(2, 52)} = 4.9759, P < 0.0105^*$ ) with Wilks' Lambda ( $P < 0.0035^*$ ). Follow-up univariate testing was conducted to provide a better understanding of how CCI at the knee and ankle joints were influenced by age groups and visual conditions. Overall, the older group had higher muscle co-contraction at both joints as compared to the younger group. However, univariate testing indicated significant differences by age group only at the ankle joint ( $F_{(1, 53)} = 10.2435, P < 0.0023^*$ ), as shown in Figure 4.26 (a). For visual conditions, the results showed significant differences at the knee joint ( $F_{(1, 53)} = 10.0974, P < 0.0025^*$ ), as shown in Figure 4.26 (b). During SWOV, ankle co-contraction was observed higher than co-contraction during SWV, but no significance was found. The means and standard deviations of integral CCI for the four groups (Young SWV, Young SWOV, Old SWV, and Old SWOV) are listed in Table 4.11.

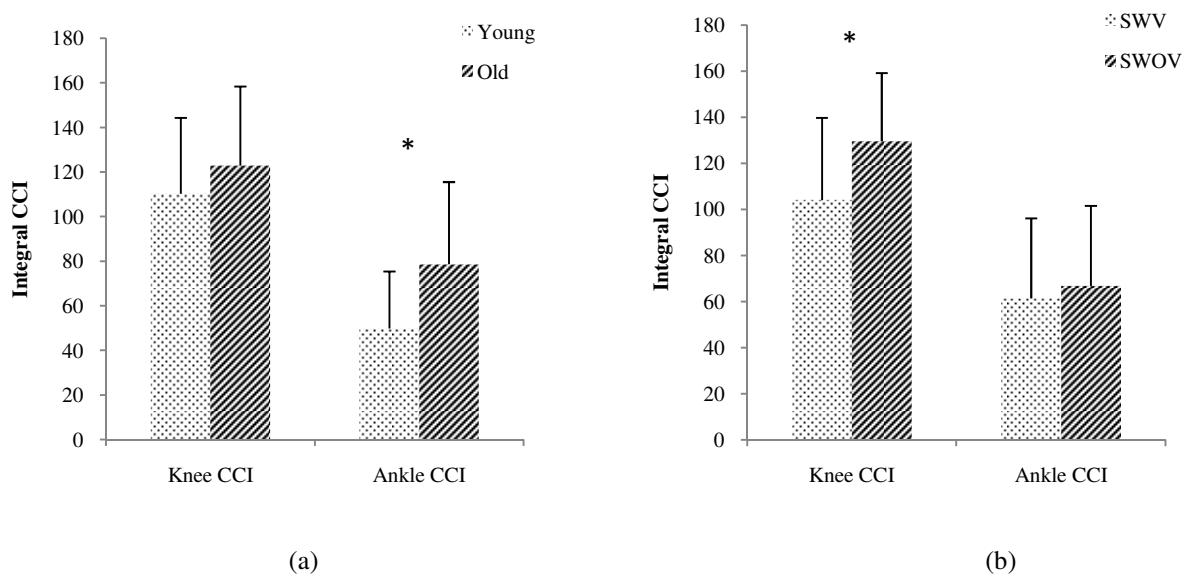

Figure 4.26 Integral muscle co-contraction index (Int CCI) at the knee and ankle joints (a) age groups and (b) during SWV and SWOV (\*  $p < 0.05$ )

Table 4.11 Mean  $\pm$  S.D. of integral CCI during SWV and SWOV between younger and older groups

Variables	Younger		Older	
	SWV	SWOV	SWV	SWOV
Int CCI Knee Joint	97.12 $\pm$ 28.39	124.70 $\pm$ 34.63	111.62 $\pm$ 41.76	134.43 $\pm$ 24.02
Int CCI Ankle Joint	49.48 $\pm$ 30.11	50.40 $\pm$ 20.66	74.12 $\pm$ 35.86	83.34 $\pm$ 38.64

#### 4.8.6 Frequency of actual falls (Fall Index)

A Fall Index was obtained by comparing sliding heel velocity (*SHV*) of the individuals during the period of slipping with slip recovery threshold. The sliding heel velocity threshold for younger adults is 144.45 cm/s and for older adults is 107.63 cm/s (Lockhart, et al., 2003). In order to objectively assess an actual fall, a fall was identified as when the *SHV* was greater than the *SHV threshold* during slipping. In addition, visual inspections of video recordings of the actual fall trials (as defined by Fall Index) were made to ensure that actual falls occurred. The result of the Fall Index indicated that 4 younger individuals (out of total of 15 participants) fell during unexpected slip perturbations. Three subjects fell one during SWV and two subjects fell once during SWOV. One of them fell twice during SWV and SWOV. Nine older individuals (out of total of 15 participants) fell during the experimental sessions. Four of them fell twice during SWV and SWOV, and the other five older participants fell during SWOV. The fall frequency was analyzed within age groups (i.e., young and old) and within visual condition (i.e., SWV and SWOV) using the Chi square ( $\chi^2$ ) test statistic. Age-related decline in sensory system may have influence recovery characteristics and increase the frequency of falls ( $\chi^2 = 6.431$ ,  $df = 1$ ,  $p=0.0112^*$ ). Although, the frequency of falls during slip with temporary loss of visual input were higher as compared with slip with visual input, the results were not statistically significant ( $\chi^2 = 0.695$ ,  $df=1$ ,  $p=0.4043$ ).

Corresponding composite initial response times of perturbed foot, unperturbed foot, arms, and muscle activity during slip with and without visual input are illustrated in Figure 4.27

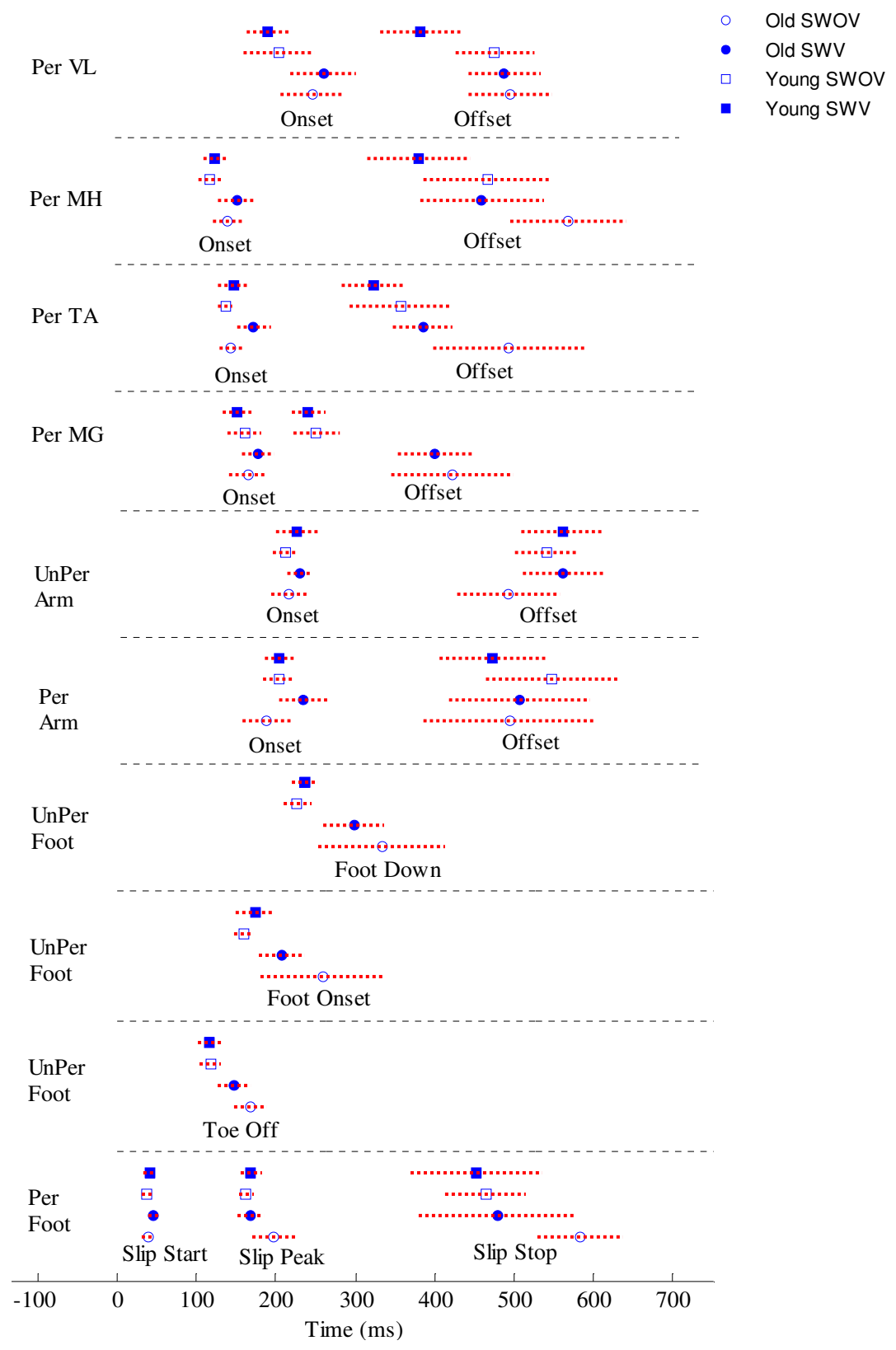
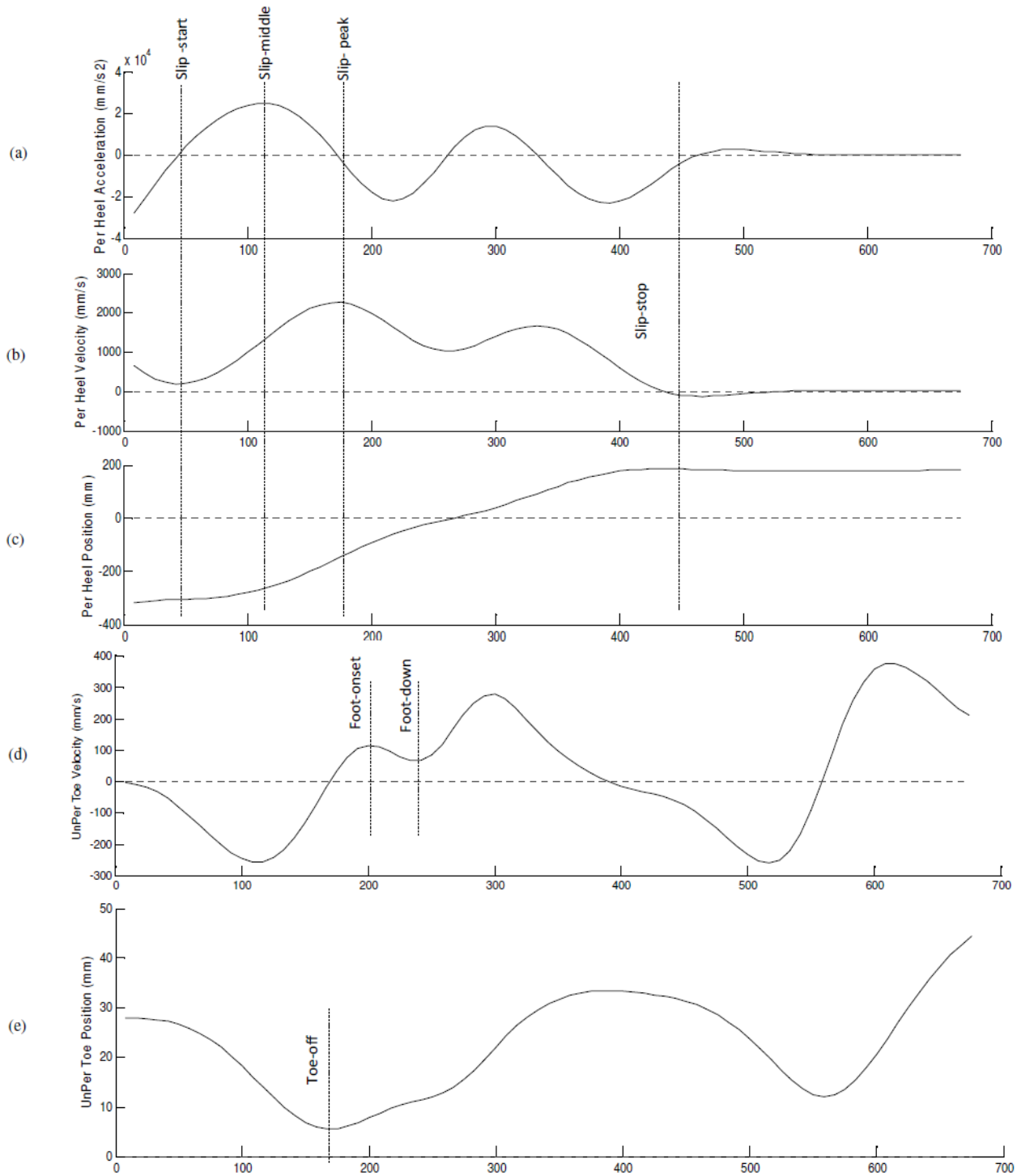
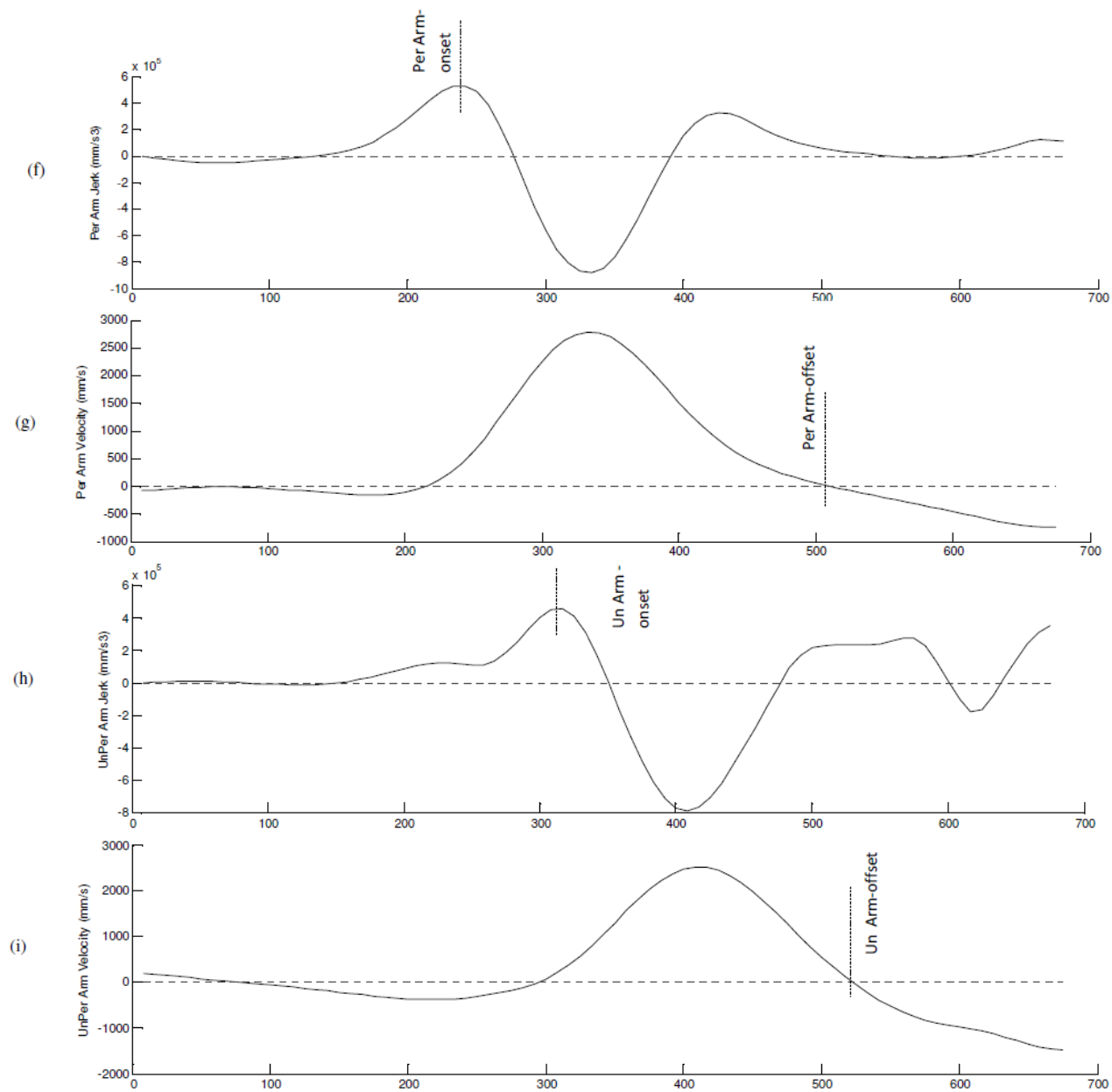

Figure 4.27 Occurrence of critical events after slip-start (Time at zero indicates heel-contact)





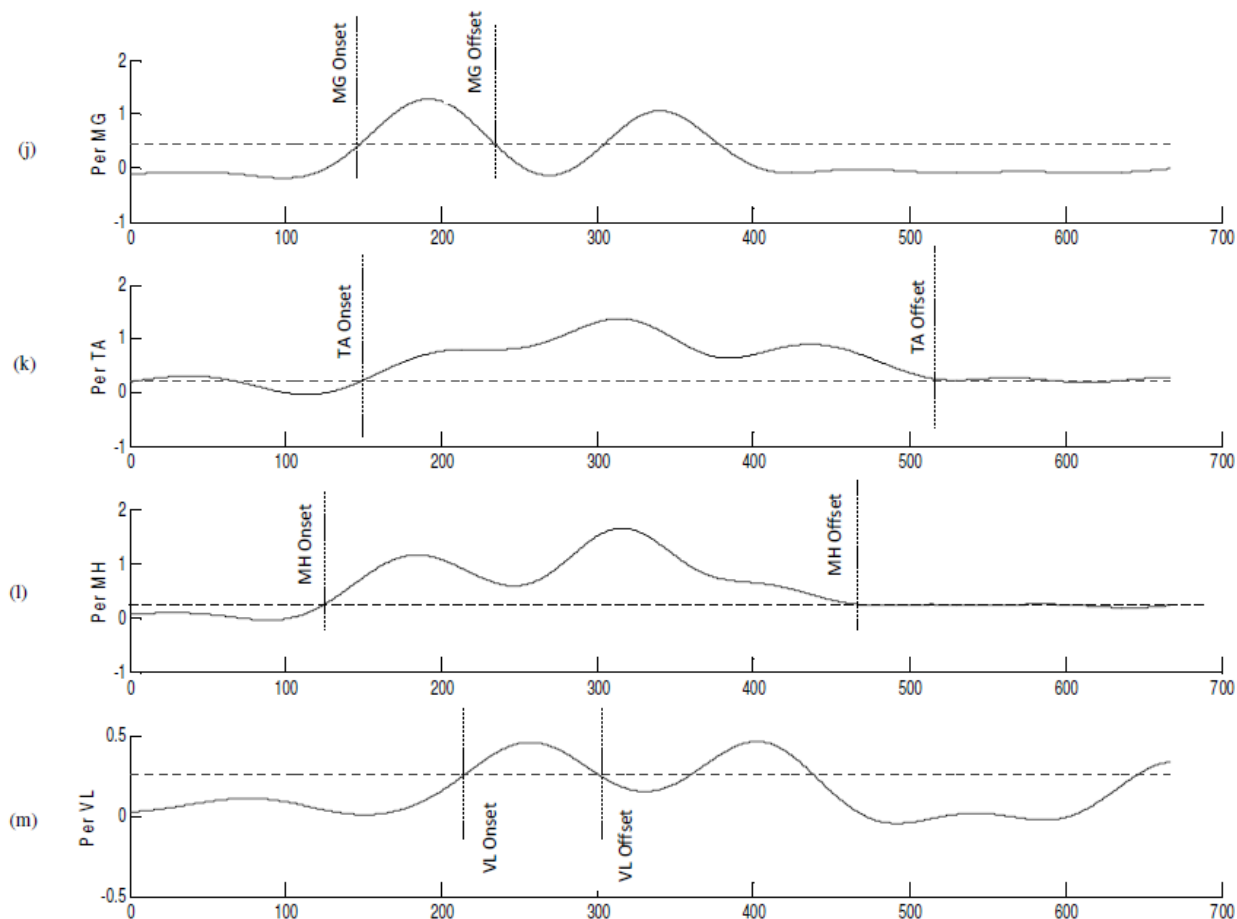

Figure 4.28 Kinematics and muscle activation composite profile after slip initiation

(a) horizontal heel acceleration on the perturbed side; (b) horizontal heel velocity on the perturbed side; (c) horizontal heel position on the perturbed side; (d) vertical toe velocity on the unperturbed side, with positive representing upward direction; (e) vertical toe position on the unperturbed side, with positive representing upward direction; (f) vertical wrist jerk on the perturbed side, with positive representing upward direction; (g) vertical wrist velocity on the perturbed side, with positive representing upward direction; (h) vertical wrist jerk on the unperturbed side, with positive representing upward direction; (i) vertical wrist velocity on the unperturbed side, with positive representing upward direction; (j~m) muscle EMG RMS on perturbed side



## 4.9 Discussion

This study examined the effects of age and visual input on gait characteristics, postural adjustments, muscle activation patterns, and muscle co-contractions during unexpected slip perturbations. The effects of temporal loss of visual input has influence slip distance, delay in slip-stop time, increase peak hip and knee flexion, cause early tibialis anterior (TA) onset, increase duration of medial hamstring (MH) activity, and increase co-contraction at the knee joint. This temporary loss of visual input during unexpected slip perturbation was more evident among older adults. The results indicated that older adults had significantly delayed slip-stop time, delayed unperturbed foot response time, increased peak ankle plantflexion and hip flexion, delayed muscle activation onset, increased muscle activity duration, and increased co-contraction at the ankle joint.

The first aim of this study was to assess the effect of the temporary loss of visual input during an unexpected slip perturbation could affect on slip distances, postural adjustments, muscle activation patterns, and muscle co-contractions. The results indicated that SDI was not influenced by the temporary loss of visual input. Regarding the mechanics of slips and falls, Lockhart, et al. (2005) described that SDI is used to provide information associated with the severity of slip initiation. The slip initiation distance (i.e., SDI) is influenced by the individuals' gait characteristics such as walking velocity. The results of this study also indicated a strong relationship between walking velocity and SDI. On the other hand, the temporal loss of visual input may cause increased slip distance II (SDII) and slip distance III (SDIII). These findings are in agreement with the study by Lockhart et al. (2005) which indicated that vision is one of the most important factors in predicting slip distance. The influence of temporal loss of visual input on slip distances can be explained by the mechanics of slips and falls, as shown in Figure 2.1. SDII is used to provide information concerning slip behavior during the detection and recovery processes (i.e., after the initiation of slips) which utilizes the integration of three sensory systems (i.e., visual, vestibular, and proprioceptive systems) (Lockhart, et al., 2005; Lockhart, et al., 2003). The temporary loss of visual input may contribute to delayed slip detection and fall recovery processes.

In term of the response times, the temporary loss of visual input may influence delayed perturbed and unperturbed foot response time. However, only the slip-stop time was significantly

delayed during the loss of visual input. Two possible causes could equally account for all of the observed response time changes associated with the temporary loss of visual input.

First, the temporary loss of visual input may delay reweighting processes to the remaining sensory systems. The motor command (i.e., desired state) from the inverse model and the real-time commands from the online controller are sent to the neuromechanical apparatus to create motor responses using fall recovery processes. During slip perturbations, visual input was used as a part of online controller in order to make real-time adjustments and provide sensory feedback to update feedback errors, as shown in Figure 4.29. Although visual input is available, it is impossible to make motor responses in a continuous way associated with the on-line controller. There is always a lag between the information from the sensory systems and the corresponding motor execution (Thomson, 1980). The reweighting process during temporary loss of visual input combined with the natural lag response in execution may cause delays in real-time and sensory feedback controls in order to create the appropriate motor response during the recovery process.

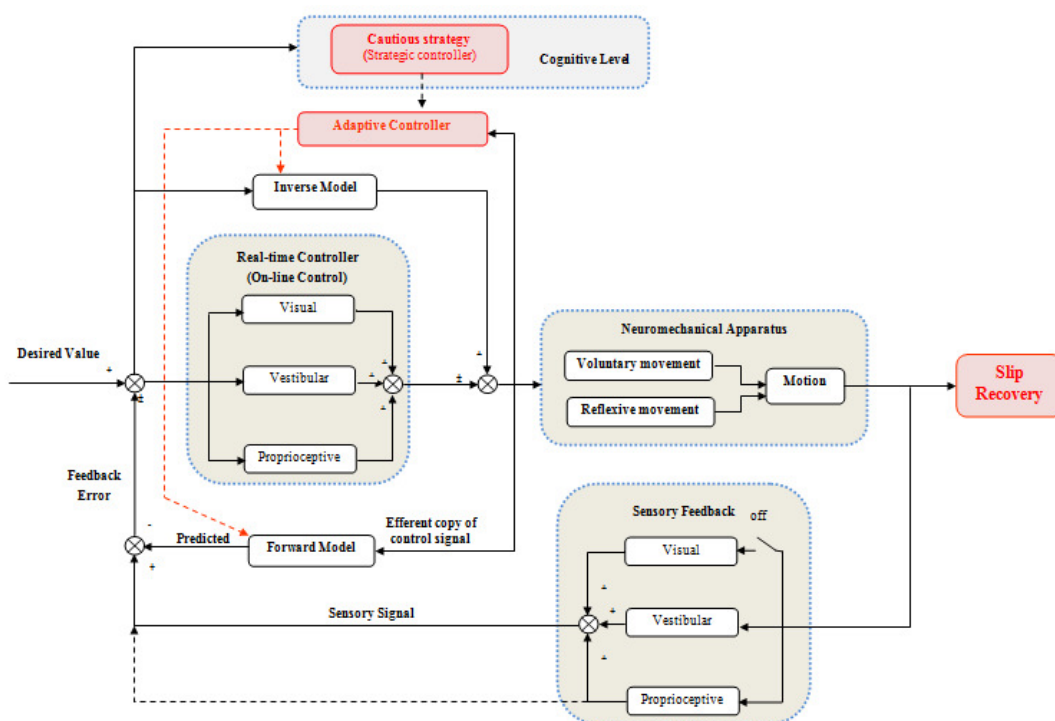

Figure 4.29 Schematic diagram of the basic human control associated with adaptive and strategic controller during unexpected slip perturbations (adopted from Sicre et al., 2008)

Second, visual feedback information may not be important for a rapid movement. The average response times associated with perturbed foot and unperturbed foot (except slip-stop time) are between 40.40 and 275.28 ms. These response times associated with dynamic stability may be considered as rapid movements which may not be improved with visual input. These results were in agreement with previous studies that investigated visual feedback and upper extremity movements. The study of Woodworth (1899) state the duration of movement of approximately 450 ms or less could not benefit from visual information. However, several studies claim that visual feedback requires a time of approximately 190-260 ms (Keele & Posner, 1968), 260-450 ms (Beggs & Howarth, 1970), and 250-300 ms (Poulton & Poulton, 1974). In this study, average perturbed and unperturbed foot response times, except slip-stop times were less than 275.28 ms which is consistent with previous studies. Thus, the findings in this study suggest that visual input is not beneficial for reciprocal movements. On the other hand, the average response time associated with slip-stop (491.53 ms) was an extended (i.e., long duration) movement which may benefit from visual input. Since the slip-stop times were longer than 450 ms, an individual's motor control may have more opportunity to utilize information from visual feedback to correct the motor response and recover from slip-induced falls.

According to the upper extremity data, the results indicated no significant effects of the temporary loss of visual input on arm response times. However, the small p-value of visual conditions ( $P < 0.1032$ ) suggest the potential of visual effects on arm response times, especially with older adults. Older individuals had earlier perturbed arm-onset while slipping with the temporary loss of visual input. The early onset of perturbed arms may occur from losing control of the arms while slipping without visual feedback. For unperturbed arms, early onset and offset were observed in both age groups while slipping with the temporary loss of visual input.

Regarding postural adjustments, overall, the temporary loss of visual input was shown to increase peak joint angles while undergoing slip perturbations. Significant effects were found on the knee and hip joint flexion. In this study, during slipping with the temporary loss of visual input, regardless of age, participants had rapid knee and hip flexion which may cause the perturbed limb to collapse, contributing to fall accidents. Peak knee, hip, and trunk angular velocities during slipping with temporary loss of visual input were observed to be faster than those angular velocities with slipping with continuous visual inputs. This finding is consistent

with previous studies that all joints were more flexed at foot contact when landing (vertical descents); and the knee joint rotation was faster with unavailable visual input (Santello, McDonagh, & Challis, 2001). Previous studies suggest that fallers failed to generate knee and hip extensor moments to prevent rapid knee and hip flexion (i.e., limb collapse) and regain balance during slip perturbations (Pai, Yang, Wening, & Pavol, 2006; Robinovitch, Chiu, Sandler, & Liu, 2000). In contrast, if knee flexion was in better control of postural adjustments, knee flexion reaction is an attempt to bring foot towards the body to stop the slip (Cham & Redfern, 2001). The findings of this study indicate that temporary loss of visual input may influence the effects of rapid knee and hip collapse. The integration of remaining sensory systems (i.e., proprioceptive and vestibular systems) may not be able to compensate for the loss of visual input. Furthermore, there was interaction between age and visual conditions on peak hip flexion. A Tukey pair-wise comparison test indicated that the older group had larger mean peak hip flexion during slip with the temporary loss of visual input as compared to other conditions. Thus, the combination of age and temporary loss of visual input may contribute to larger hip flexion angles which contribute to the perturbed limb collapse and resulting falls.

In terms of muscle activation patterns, early muscle activity onset of MG, TA, MH, and VL muscles were observed while slipping with temporary loss of visual input, but a significant difference was only found at TA. The muscle activity of TA was indicated to be very important in dynamic balance control (i.e., recover from slip-induced falls) (Tang, et al., 1998) since the TA activity is utilized in regaining ankle joint trajectory during a slip. Early TA onset during a slip without visual input may occur because the ankle joint attempted to create ankle plantarflexion (i.e., increased foot-floor angle) in order to compensate for the temporary loss of visual input. The muscle activity duration during slip with temporary loss of visual input was longer than slip with continuous visual input. However, only medial hamstrings (MH) duration was significantly affected by temporary loss of visual input. Lockhart & Kim (2006) indicated that the primary purpose of MH activation is to decelerate the perturbed limbs and assist in decreasing the potential of slips and falls. During a slip, medial hamstrings (MH) may activate longer to compensate for temporary loss of visual input and to slow down the perturbed limb. Longer activation of MH also assists with control and stabilization the slip limbs (Chambers & Cham, 2007).

Temporary loss of visual input during unexpected slip perturbations also had a significant effect on co-contraction of muscle at the ankle and knee joints, but a significant difference was only found at the knee joint. Increased co-contraction at the knee joint may be associated with increased duration of MH activity. These findings are in agreement with previous studies (Collins & Luca, 1995; Collins, et al., 1995; Onambélé, et al., 2007) that loss of visual input increases the joint stiffness. Temporary loss of visual input during unexpected slips may cause increased co-activation of agonist and antagonist (i.e., TA/MG and VL/MH) muscles, contributing to stiffness at the ankle and knee joints. Loss of visual input during unexpected slip perturbations may be classified as an unexpected task which requires new skills. Increased stiffness of human limbs often occurs during the learning of a new skill (Burdet, Osu, Franklin, Milner, & Kawato, 2001). Tang, et al. (1998) suggested that the co-contraction between two pair of muscle groups was found to be the key to reactive recovery during lost balance. In contrast, increased co-contraction may create stiffness at the ankle and knee joints which causes increased difficulty in detecting slip-induced falls. This stiffness may also contribute to reduced flexibility and adaptability to recover from slip-induced falls (Horak, et al., 1992). Marigold, et al., (2003) suggested that stiffness at the knee joint interrupts a quick reaction during slip and fall recovery. Therefore, increased co-contraction at the ankle and knee joints while slipping with the loss of visual input may contribute to high risk of falls.

The temporary loss of visual input during unexpected slip perturbation had more effects on older adults. The results in this study suggest that young adults had longer SDI than older adults. As discussed earlier, SDI was significantly correlated with walking velocity, and younger adults walked faster than older adults. Although there were no significant differences of SDII and SDIII between age groups, the elderly were affected more than the young by temporary loss of visual input as shown in increased SDII and SDIII. These findings were in agreement with previous studies (Lockhart, et al., 2005; Lockhart, et al., 2003) that older individuals had longer SDII as compared to their younger counterparts. Increased slip distances in older group may be explained by the mechanics of slips and falls. SDII and SDIII have been related to the slip detection and fall recovery processes. Age-related declines in sensory systems may influence the ability to detect environmental changes (i.e., slippery surfaces), especially during loss of visual input. In this study, younger adults had faster sliding heel velocities and peak sliding heel velocities than older adults. This can be explained by the correlation between walking velocities

and sliding heel velocity. Younger adults who have a fast walking velocity may also have faster sliding heel velocities during slips.

According to response times, older individuals had slower perturbed and unperturbed foot response times as compared to their younger counterparts. However, slip-stop time for the perturbed foot and all response times (toe-off, foot-onset, and foot-down) for unperturbed foot were significantly different between age groups. This finding was in agreement with Lockhart (2008) that older individuals have slower perturbed and unperturbed foot response times than younger individuals. Shortly after toe-off, the unperturbed foot was controlled to create foot-down (i.e., toe touch) by utilizing the hamstring and vastus lateralis muscles (Lockhart, 2008) in order to increase the base of support and recover from slip-induced falls. The delay of unperturbed response times in older adults may be influenced by the delay of slip-stop times and the delay of MH and VL onset among older adults.

In terms of the arms, younger individuals' arm-onset was faster than older adults but not significantly different between age groups. Consistent with previous studies (Lockhart, 2008; Tang & Woollacott, 1998), older adults were delayed in the use of their arm reactions for balance maintenance. The rapid response of the arm swing after slip-start assists in recovering from slip-induced falls by increasing the base of support and bring the COM back within the base of support respectively (Lockhart, 2008; Marigold, et al., 2003). In this study, all younger adults swung their arms either during a slip with continuous visual input or temporary loss of visual input. Young adults tend to swing their arms to recover balance. On the other hand, several older adults did not swing their arms during their slips. There were three older adults who dropped (i.e., not swung) their perturbed arms during slip with continuous visual input; and five older adults dropped their perturbed arms during slip with the temporary loss of visual input. This finding is consistent with Maki and McIlroy (2006) that older adults tend to move their arms in the direction of the fall. This may indicated the natural arm responses in older adults as a protective response by using their arms to cushion the impact of the fall to protect their body. The elderly may not realize that using their arms to cushion the impact of the fall may result in upper limb fractures. As discussed, older adults tend to have delayed arm response times, and a smaller swing in the opposite vertical direction, in comparison with younger adults. An implementation of these study results may be to find the optimal height for the safety hand rails,

which assists the elderly during the fall recovery process. Age-related musculoskeletal and neuromuscular deficits may increase the difficulty of fast postural adjustments and recover from slip-induced falls in older individuals. In light of this evidence, age-related sensory degradation and the temporary loss of visual input may impact the online controller and sensory feedback on adaptive capabilities during fall recovery. Thus, age-related effects combined with visual loss may contribute to the slowing of neural processing and limit the capacity to generate rapid movement.

Regarding postural adjustments, older adults had larger peak joint angles than their younger counterparts. However, age-related effects were only significant on peak ankle plantarflexion and peak hip flexion. Rapid postural changes among older adults may occur from muscular and sensory degradation which contributes to decline ability to control postural adjustments. The results also indicate that older adults had slower shoulder angular velocity while regaining balance by swinging their upper limbs, in comparison to younger adults. Consistent with these results, slower shoulder angular velocity was observed in the elderly as compare with their younger counterparts (Maki & McIlroy, 2006). Older adults may have slower shoulder angular velocity because they have slower arm velocity and a smaller swing in the opposite vertical direction, as compared to younger adults.

In terms of muscle activation patterns, older adults had slower muscle activity onset than younger adults, however, in this study the significant differences were found at MH and VL. Finding that older adults had delay muscle activity onset is in agreement with previous studies (Lockhart & Kim, 2006; Tang & Woollacott, 1998; Winter, 1991). Lockhart and Kim (2006) suggested that a faster rate of the MH activity in young adults assists them in reducing the heel-contact velocity. Thus, slower onset of MH and VL may affect postural adjustments that contributed to controlling the heel-contact velocity and reducing rapid knee and hip flexion among older adults in this study. The older group also has longer durations of muscle activity than their younger counterparts. These findings are consistent with previous studies that during slip perturbations, the duration of MG and TA activation in older group are significantly longer, as compared with younger groups (Tang & Woollacott, 1998; Woollacott & Tang, 1997). The longer durations of muscle activation in older adults is part of an adaptive strategy in order to

compensate for sensory degradations, declined strength, and loss of fast and slow twitch muscle fiber.

The results of this study also indicate that the age-related effects of muscle co-contractions during slip perturbations. These findings are consistent with previous studies (Chambers & Cham, 2007; Ferri, et al., 2003; Psek & Cafarelli, 1993; Tang & Woollacott, 1998; Woollacott & Tang, 1997) that co-contraction at the ankle and knee joints among older adults was higher than younger adults, but only co-contraction at the ankle joint was significantly different between age groups. As discussed earlier, increased ankle muscle co-contraction could assist in reducing risk of slips and falls, but too much ankle co-contraction may decrease a person's ability to detect slip-induced falls. Thus, higher ankle co-contraction among older adults not only affects their ability to detect slippery surface but also reduces flexibility used during the fall recover process (Chambers & Cham, 2007; Horak, 1992; Tang & Woollacott, 1998).

In summary, regardless of age, the temporary loss of visual input affected the ability to detect changing surfaces (i.e., contamination on the floor) and recover from slip-induced falls. The rapid movements during fall recovery (approximately 450 ms or less) were not affected from the temporary loss of visual input. The reweighting process to utilize remaining sensory systems may not fully compensate for the lack of visual input. The on-line controller and sensory feedback systems may be less accurate in receiving environmental information and may cause increased errors in the feedback system which is used in correcting the motor responses. Thus, the age-related declines combined with temporary visual occlusion may influence increased peak knee and hip flexion and joint angular velocity which may cause the perturbed limb to collapse, leading to falls among older adults.

Furthermore, this study also indicates that the loss of visual input may enhance the gain of proprioceptive system during the reweighting process. This finding is consistent with previous studies (Kiemel, Oie, & Jeka, 2002; Peterka & Loughlin, 2004). The proprioceptive gain was observed from the muscle activation pattern, adapted to create early muscle activity onset, longer duration of muscle activity, and higher co-contractions to compensate for loss of visual input during recovery from slip-induced falls. This finding may be used to fulfill a gap in the research related to the influence of age-related effects associated with visual input on locomotion and detection and recovery from slip-induced falls.



## CHAPTER 5

### Summary and Conclusions

#### 5.1 Summary

Falls are one of the most serious accidents related to significant injuries and medical costs in older adults. Three sensory inputs, including the visual, proprioceptive, and vestibular systems are redundant and relevant for balance maintenance (Lockhart, et al., 2005). The postural control system uses each sensory system separately as well as in an integrative manner in which sensory systems are reweighted to maintain stability in challenging conditions (e.g., slippery surfaces) (Nashner, 1976; Oie, et al., 2002). Decreasing stability with increasing age is due to sensory degradation (Lockhart, 2008; Lockhart, et al., 2005). Previous studies indicated that visual dependent behavior among older individuals may cause them to rely on visual input that may be inaccurate or unreliable to use in regaining balance (Allison, et al., 2006; Simoneau, et al., 1999; Sundermier, et al., 1996; Wade, et al., 1995). Sensory degradation in older adults may increase the time taken to reweight the multi-sensory systems during slip-induced falls, and increase the risk of falls (Teasdale & Simoneau, 2001). Numerous studies have reported the influence of visual input on static postural stability, although the static postural behavior (e.g., quiet stance) is barely representative of a loss of balance in real world situations. To address this gap, the influence of age-related visual input during slip-induced falls was investigated in young and older adults.

This objective of the study I was to investigate the age-related effects of visual input on multi-sensory processing during normal walking. The gait characteristics (step length, step width, step duration) and joint angles immediately after visual occlusion were not affected by the temporary loss of visual input. This result suggests that the gait characteristics and postural control of the future step may depend on the pre-structured motor commands (i.e., ballistic strategy ) before toe-off of the rear foot (Brenière & Do, 1991; Patla, 1997; Roberts & Roberts, 1978). However, the temporary loss of visual input during locomotion may cause longer double support time of the subsequence step in the older group. During temporary loss of visual input, older adults may adopt a cautious strategy to compensate for their physical and neuronal declines

(Guimaraes & Isaacs, 1980). Moreover, the loss of visual input may influence increased co-contraction at the knee joint, resulting in stiffer joints. Older adults also have higher co-contraction at the ankle joint, as compared with young adults. Age-related effects combined with the temporary loss of visual input may increase difficulty initiating a slip associated with excessive joint stiffness. The worst case scenario could happen when an elderly person experiences a loss of visual input when stepping onto a slippery surface. This stiffness may reduce flexibility that is required to recover from a slip-induced fall.

The proposed research of study II was to investigate the age-related effects of visual input on multi-sensory process during unexpected slip perturbations. Temporary loss of visual input increased in slip distances (SDII and SDIII) and delayed slip-stop time. As discussed earlier, the temporary loss of visual input is relevant to the detection process in the mechanics of slips and falls (Lockhart, et al., 2005), resulting in increased SDII and SDIII. There was delayed foot and arm response times observed during slip with the temporary loss of visual input. The results from this study improve knowledge concerning the visual input associated with the response times related to dynamic stability (i.e., slip-induced falls). As discussed in chapter 4, the effects of visual input on human movement have been studied with upper limb movements. The findings suggest that the temporary loss of visual input disrupt ability to control postural adjustments and movements of lower extremity (i.e., controlling the heel velocity to achieve a slip-stop event). Thus, the knowledge gained from this study can support the previous notions that visual input is beneficial for controlling movements which requires response time of about 450 ms or greater. In terms of kinematic angular parameters, temporary loss of visual input increased peak knee and hip flexion during slip perturbations which may result in rapid knee and hip collapse and increase the likelihood of falls. This finding may suggest that the integration of proprioceptive and vestibular systems may not be able to compensate for the loss of visual input during slips in controlling postural adjustments and regaining stability.

The temporary loss of visual input may influence the gain of proprioceptive system in order to compensate for the loss of visual input as results in early TA muscle activity onset, increased duration of MH activity, and increased the co-contraction at the knee joint. An early TA onset during slip without visual input may occur because the ankle joint attempts to create ankle plantarflexion to create flat-foot on the surface and to compensate for the temporary loss of visual input. The MH may be activated longer during uncertain situation to decelerate the

perturbed limbs and assist in decreasing the potential of slips and falls (Chambers & Cham, 2007; Lockhart & Kim, 2006). Finally, increased co-contraction at the knee joint may be associated with increased duration of MH activity while slipping with temporary loss of visual input. The simultaneity of losing balance and visual input may increase the co-activation of muscles at the thigh segment to enhance the ability to maintain balance and decelerate sliding heel velocity to recover from slip-induced falls.

Moreover, the age-related effects combined with the temporary loss of visual input may influence the difficulty of the fall recovery process as increased slip-stop time, increased peak hip flexion, delay muscle activation onset, increased muscle activity duration and increased muscle co-contraction. The age-related declines in the sensory systems of older adults may influence their ability to detect environmental changes (i.e., slippery surfaces) especially during loss of visual input. Moreover, sensory degradation and musculoskeletal defects may affect the upper and lower limbs' response time associated with fall recovery process and may cause the delay of muscle activity onset and increase muscle activity duration. Longer durations of muscle activation in older adults is part of an adaptive strategy in order to compensate for sensory degradations, declined strength, and loss of fast and slow twitch muscle fiber (Lockhart, 2008; Tang & Woollacott, 1998). Increased muscle co-contraction may assist older adults to hold their body and reduce the risk of slips and falls, however too much co-contraction may decrease one's ability to detect and recover from slip-induced falls. These findings indicate that the combination of age and temporary loss of visual input could cause the perturbed limb to collapse and result in falls among the elderly.

Findings in muscle activation patterns indicate that the proprioceptive gain increases while walking and slipping with temporary loss of visual input. The visual occlusion paradigm could strengthen adaptation in the sensory reweighting process, enhancing the gain of proprioceptive system and contributing to robust motor learning (Torres-Oviedo & Bastian, 2010). Regarding dynamical systems, human movements variability, considered as an intrinsic coordinates, provides the flexibility required to adapt to complex environments (A. M. Williams, Davids, & Williams, 1999). Visual occlusion training might increase the learning of encoded intrinsic coordinates related to motor performance skill (Shadmehr & Mussa-Ivaldi, 1994; Torres-Oviedo & Bastian, 2010) more than learning encoding in extrinsic coordinates, related to the environmental information. Visual control is important for learning new skills, however,

proprioceptive feedback becomes more important (Fitts, 1951). The temporal visual occlusion paradigm has been applied in sports training such as tennis, badminton, and soccer to train athletes' intrinsic skill performance (Farrow, Abernethy, & Jackson, 2005; Hagemann & Strauß, 2006; A. Williams & Davids, 1998). However, the temporal visual occlusion paradigm is not fully implemented into clinical implications. Haran & Keshner (2008) applied this paradigm with patients who have a bilateral labyrinthine deficit to train their proprioceptive feedback to improve postural stability. Torres-Oviedo & Bastian (2010) also applied the temporal visual occlusion paradigm to improve the transfer of learning and reduce carrying effect of locomotor adaptation from walking on treadmill to walking overground. Task-specific training could enhance the ability of adaptive control to improve the reactive response (Parijat, 2009; Pavol, Runtz, & Pai, 2004) and stability with feedforward control (Pai, Wening, Runtz, Iqbal, & Pavol, 2003; Pavol & Pai, 2002) during experiencing slip-induced falls. Training programs which occludes visual input during slip perturbations may assist to enhance the weighting process to proprioceptive and vestibular inputs and to improve the motor learning of the fall recovery process.

## **5.2 Limitations and Future Recommendations**

Several limitations exist in this study. Firstly, the glasses controller set has a limitation in terms of occlusion time. The wireless relay car door security remote control (ENFORCER SK-910 Series RF Receivers) was applied to control PLATO: Portable Liquid-crystal Apparatus for Tachistoscopic Occlusion. After the receiver located above the hardness system received a signal from a remote control connected to the photo sensor, the relay contact of the receiver can make the shortest surface contact about 573 ms. Thus, the controller set cannot make the occlusion time in this study exactly to 500 ms. Secondly, the occlusion time was limited at one level (~500 ms at heel contact). Therefore, varied visual occlusion times at different gait events (e.g., heel-contact, mid swing, or toe-off) should be investigated in order to understand more about the influence of temporary loss of visual input on human gait and response. Thirdly, gait parameter differences (i.e., step length and step width) may be attributed to anthropometric variables such as height or leg length (Owings & Grabiner, 2004). Finally, motion analysis cannot capture the

farther step. The results might indicate more significant effects of visual occlusion on the step after the subsequent step. Future studies should examine additional steps after visual occlusion.

### 5.3 Conclusions

Existing studies indicate that the influence of age-related changes on visual input during static stability (Blaszczyk, Prince, Raiche, & Hébert, 2000; Collins, et al., 1995). However, the age-related changes on visual input during dynamic stability are still unclear. The goal of this study was to fulfill a gap in the research related to the influence of age-related effects associated with visual input on locomotion and detection and recovery from slip-induced falls. The temporary loss of visual input was the influence on the mechanism of human gait (i.e., walking) and dynamic stability (i.e., recovering from slip-induced falls) in both age groups. However, this temporary loss of visual input had more influence among older adults. Although visual input is not beneficial for controlling rapid slip limb movements, visual input is important for regaining dynamic stability (i.e., recovery from slip-induced falls). The human body could not fully compensate for the temporary loss of visual input. In the other words, human motor control requires continuous visual feedback during the fall recovery processes. The effects of age and the temporary loss of visual input could cause the on-line controller and sensory feedback to delay the reweight process to the remaining sensory systems in order to compensate for the loss of visual input. Although the loss of visual input may cause inaccuracy of feedback errors and delayed motor responses during fall recovery, the visual occlusion paradigm could enhance the proprioceptive gain while maintaining stability (Kiemel, et al., 2002; Peterka & Loughlin, 2004; Torres-Oviedo & Bastian, 2010). The gain of proprioceptive in this study shows in changing of the muscle activation patterns and co-contraction while slipping with the temporary loss of visual input.

This finding has an important implication in future research for order to better understand the potential hazards which could occur while walking and slipping with temporary loss of visual input. These results could also be used to design effective interventions to improve motor learning and reduce fall risk and enhance safety. The interventions can be applied to older adults who rely heavily on visual input as well as workers to enhance occupational safety during walking and carrying loads. The visual occlusion paradigm could strengthen the adaptation in the

sensory reweighting process. The training program which occludes visual input during slip perturbations may assist in enhancing the reweighting process to available inputs (proprioceptive and vestibular inputs), contributing to robust motor learning (Torres-Oviedo & Bastian, 2010).

Among the elderly, the proprioceptive and vestibular systems should be trained not only to correct the visual dependent behavior, but also to enhance the ability of both systems in the detection of slips and recovery from falls. Therefore, specific training by visual occlusion during slip perturbations may be another alternative to train aging populations and individuals with sensory deficits to enhance their proprioceptive and vestibular systems in order to maintain balance and enhance fall recovery.

## Reference

- Al-Zamil, Z. (1998). Use of Long Loop Reflexes to Assess Postural Control Following Stroke. *Neurorehabilitation and Neural Repair*, 12(1), 23.
- Allison, L., Kiemel, T., & Jeka, J. (2006). Multisensory reweighting of vision and touch is intact in healthy and fall-prone older adults. *Experimental Brain Research*, 175(2), 342-352.
- Altman, D. (1991). *Practical statistics for medical research*: Chapman & Hall/CRC.
- Barnett-Cowan, M., & Harris, L. (2009). Perceived timing of vestibular stimulation relative to touch, light and sound. *Experimental Brain Research*, 198(2), 221-231.
- Baxter, B., & Travis, R. (1938). The reaction time to vestibular stimuli. *Journal of Experimental Psychology*, 22(3), 277-282.
- Beggs, W., & Howarth, C. (1970). Movement control in a repetitive motor task.
- Benjuya, N., Melzer, I., & Kaplanski, J. (2004). Aging-induced shifts from a reliance on sensory input to muscle cocontraction during balanced standing. *The Journals of Gerontology Series A: Biological Sciences and Medical Sciences*, 59(2), M166.
- Bent, L., Inglis, J., & McFadyen, B. (2004). When is vestibular information important during walking? *Journal of neurophysiology*, 92(3), 1269.
- Bent, L., McFadyen, B., & Inglis, J. (2005). Vestibular contributions during human locomotor tasks. *Exercise and sport sciences reviews*, 33(3), 107.
- Bergström, B. (1973). Morphology of the vestibular nerve: II. The number of myelinated vestibular nerve fibers in man at various ages. *Acta oto-laryngologica*, 76(1), 173-179.
- Blaszczyk, Prince, F., Raiche, M., & Hébert, R. (2000). Effect of ageing and vision on limb load asymmetry during quiet stance. *Journal of Biomechanics*, 33(10), 1243-1248.
- Bohannon, R., Larkin, P., Cook, A., Gear, J., & Singer, J. (1984). Decrease in timed balance test scores with aging. *Physical Therapy*, 64(7), 1067.
- Brady, R., J. Pavol, M., Owings, T., & Grabiner, M. (2000). Foot displacement but not velocity predicts the outcome of a slip induced in young subjects while walking. *Journal of Biomechanics*, 33(7), 803-808.
- Brenière, Y., & Do, M. C. (1991). Control of gait initiation. *Journal of motor behavior*.
- Brocklehurst, J., Robertson, D., & James-Groom, P. (1982). Clinical correlates of sway in old age--sensory modalities. *Age and ageing*, 11(1), 1.
- Bruner, A., & Norris, T. (1971). Age-related changes in caloric nystagmus. *Acta oto-laryngologica. Supplementum*, 282, 1.
- Burdet, E., Osu, R., Franklin, D. W., Milner, T. E., & Kawato, M. (2001). The central nervous system stabilizes unstable dynamics by learning optimal impedance. *Nature*, 414(6862), 446-449.
- Carson, R., & Riek, S. (2001). Changes in muscle recruitment patterns during skill acquisition. *Experimental Brain Research*, 138(1), 71-87.
- CDC. (2010). Falls among older adults: an overview. Retrieved Aug 12, 2011, from <http://cdc.gov/HomeandRecreationalSafety/Falls/adultfalls.html>
- Cesari, M., Landi, F., Torre, S., Onder, G., Lattanzio, F., & Bernabei, R. (2002). Prevalence and risk factors for falls in an older community-dwelling population. *Journals of Gerontology Series A: Biological and Medical Sciences*, 57(11), 722.
- Chaffin, D., Woldstad, J., & Trujillo, A. (1992). Floor/shoe slip resistance measurement. *American Industrial Hygiene Association Journal*, 53(5), 283-289.
- Cham, R., & Redfern, M. (2001). Lower extremity corrective reactions to slip events. *Journal of Biomechanics*, 34(11), 1439-1445.
- Chambers, A. J., & Cham, R. (2007). Slip-related muscle activation patterns in the stance leg during walking. *Gait & Posture*, 25(4), 565-572.
- Collins, J., & Luca, C. (1995). The effects of visual input on open-loop and closed-loop postural control mechanisms. *Experimental Brain Research*, 103(1), 151-163.

- Collins, J., Luca, C., Burrows, A., & Lipsitz, L. (1995). Age-related changes in open-loop and closed-loop postural control mechanisms. *Experimental Brain Research*, 104(3), 480-492.
- Courtney, T., Sorock, G., Manning, D., Collins, J., & Holbein-Jenny, M. (2001). Occupational slip, trip, and fall-related injuries—can the contribution of slipperiness be isolated? *Ergonomics*, 44(13), 1118-1137.
- Diener, H., Dichgans, J., Guschlbauer, B., & Mau, H. (1984). The significance of proprioception on postural stabilization as assessed by ischemia. *Brain research*, 296(1), 103-109.
- Droller, H., & Pemberton, J. (1953). Vertigo in a random sample of elderly people living in their homes. *The Journal of Laryngology and Otology*, 67(11), 689-694.
- Enoka, R. (1997). Neural strategies in the control of muscle force. *Muscle & nerve*, 20(S5), 66-69.
- Falconer, K., & Winter, D. (1985). Quantitative assessment of co-contraction at the ankle joint in walking. *Electromyography and clinical neurophysiology*, 25(2-3), 135-149.
- Farrow, D., Abernethy, B., & Jackson, R. (2005). Probing expert anticipation with the temporal occlusion paradigm: Experimental investigations of some methodological issues. *Motor control*, 9(3), 332.
- Ferri, A., Scaglioni, G., Pousson, M., Capodaglio, P., Van Hoecke, J., & Narici, M. (2003). Strength and power changes of the human plantar flexors and knee extensors in response to resistance training in old age. *Acta Physiologica Scandinavica*, 177(1), 69-78.
- Fitts, P. M. (1951). Engineering psychology and equipment design.
- Fleming, B., & Pendergast, D. (1993). Physical condition, activity pattern, and environment as factors in falls by adult care facility residents. *Archives of Physical Medicine and Rehabilitation*, 74(6), 627-630.
- Friigo, C., & Shiavi, R. (2004). *Applications in movement and gait analysis*. In: R. Merletti and P. Parker, eds., *Electromyography: Physiology, Engineering and Applications*. Piscataway, NJ: IEEE Press.
- Garner, J., Wade, C., MacDonald, C., & Lamont, H. (2011). Knee Musculature Co-Contraction Following Extended Durations of Walking in Work Boots. *The Journal of Strength & Conditioning Research*, 25, S74.
- Gauchard, G., Chau, N., Mur, J., & Perrin, P. (2001). Falls and working individuals: role of extrinsic and intrinsic factors. *Ergonomics*, 44(14), 1330-1339.
- Ghez, C. (1991). *The control of movement*. In: Kandel ER, Schwartz JH, Jessell TM, *Principles of neural science*. New York, NY: Elsevier Science.
- Gibson, J. (1958). Visually controlled locomotion and visual orientation in animals. *British Journal of Psychology*(49), 182-194.
- Gibson, J., & Gibson, E. (1955). PERCEPTUAL LEARNING: DIFFERENTIATION OR ENRICHMENT? *Psychological Review*, 62(1), 32-41.
- Grönqvist, R. (1995). A dynamic method for assessing pedestrian slip resistance. *Finnish Institute of Occupational Health (Hrsg.). People and Work Research Reports*, 2.
- Grönqvist, R., Hirvonen, M., & Tuusa, A. (1993). Slipperiness of the shoe-floor interface: comparison of objective and subjective assessments. *Applied Ergonomics*, 24(4), 258-262.
- Grönqvist, R., Roine, J., Järvinen, E., & Korhonen, E. (1989). An apparatus and a method for determining the slip resistance of shoes and floors by simulation of human foot motions. *Ergonomics*, 32(8), 979-995.
- Guimaraes, R., & Isaacs, B. (1980). Characteristics of the gait in old people who fall. *Disability & Rehabilitation*, 2(4), 177-180.
- Hagemann, N., & Strauß, B. (2006). Perceptive Expertise von Badmintonspielern. *Zeitschrift für Psychologie/Journal of Psychology*, 214(1), 37-47.
- Hasan, Z., & Stuart, D. (1988). Animal solutions to problems of movement control: the role of proprioceptors. *Annual review of neuroscience*, 11(1), 199-223.
- Hof, A., Elzinga, H., Grimmius, W., & Halbertsma, J. (2005). Detection of non-standard EMG profiles in walking\* 1. *Gait & Posture*, 21(2), 171-177.
- Hollands, M. A., & Marple-Horvat, D. E. (1996). Visually guided stepping under conditions of step cycle-related denial of visual information. *Experimental Brain Research*, 109(2), 343-356.



- Hollands, M. A., Patla, A. E., & Vickers, J. N. (2002). "Look where you're going!": gaze behaviour associated with maintaining and changing the direction of locomotion. *Experimental Brain Research*, 143(2), 221-230.
- Horak, F. (1992). Effects of neurological disorders on postural movement strategies in the elderly. *Falls, Balance, and Gait Disorders in the Elderly*. Paris, France: Elsevier Science Publishers, 137-151.
- Horak, F., Henry, S., & Shumway-Cook, A. (1997). Postural perturbations: new insights for treatment of balance disorders. *Physical Therapy*, 77(5), 517.
- Horak, F., Nashner, L., & Diener, H. (1990). Postural strategies associated with somatosensory and vestibular loss. *Experimental Brain Research*, 82(1), 167-177.
- Horak, F., Nutt, J., & Nashner, L. (1992). Postural inflexibility in parkinsonian subjects. *Journal of the Neurological Sciences*, 111(1), 46-58.
- Horn, B., & Schunck, B. (1981). Determining optical flow. *Computer vision*, 17, 185-203.
- Hunter, M., & Hoffman, M. (2001). Postural control: visual and cognitive manipulations. *Gait & Posture*, 13(1), 41-48.
- Hurley, M., Rees, J., & Newham, D. (1998). Quadriceps function, proprioceptive acuity and functional performance in healthy young, middle-aged and elderly subjects. *Age and ageing*, 27(1), 55.
- Inglis, J., Shupert, C., Hlavacka, F., & Horak, F. (1995). Effect of galvanic vestibular stimulation on human postural responses during support surface translations. *Journal of neurophysiology*, 73(2), 896.
- Ivers, R. Q., Optom, B., Cumming, R. G., Mitchell, P., Simpson, J. M., & Peduto, A. J. (2003). Visual risk factors for hip fracture in older people. *Journal of the American Geriatrics Society*, 51(3), 356-363.
- Kadaba, M., Ramakrishnan, H., Wootten, M., Gainey, J., Gorton, G., & Cochran, G. (1989). Repeatability of kinematic, kinetic, and electromyographic data in normal adult gait. *Journal of Orthopaedic Research*, 7(6), 849-860.
- Kandel, E., Schwartz, J., & Jessell, T. (1991). *Principles of neural science*: Elsevier New York.
- Kararizou, E., Manta, P., Kalfakis, N., & Vassilopoulos, D. (2005). Morphometric study of the human muscle spindle. *Analytical and quantitative cytology and histology/the International Academy of Cytology [and] American Society of Cytology*, 27(1), 1.
- Keele, S. W., & Posner, M. I. (1968). Processing of visual feedback in rapid movements. *Journal of Experimental Psychology*, 77(1), 155.
- Kenny, R., Rubenstein, L., Martin, F., & Tinetti, M. (2001). Guideline for the prevention of falls in older persons. *J Am Geriatr Soc*, 49(5), 644Y672.
- Kenshalo, D. (1986). Somesthetic sensitivity in young and elderly humans. *The Journal of Gerontology*, 41(6), 732.
- Keshner, E., Woollacott, M., & Debu, B. (1988). Neck, trunk and limb muscle responses during postural perturbations in humans. *Experimental Brain Research*, 71(3), 455-466.
- Kiemel, T., Oie, K. S., & Jeka, J. J. (2002). Multisensory fusion and the stochastic structure of postural sway. *Biological Cybernetics*, 87(4), 262-277.
- King, M., Judge, J., & Wolfson, L. (1994). Functional base of support decreases with age. *Journal of Gerontology*, 49(6), M258.
- Kristinsdottir, E., Jarnlo, G., & Magnusson, M. (2000). Asymmetric vestibular function in the elderly might be a significant contributor to hip fractures. *Journal of Rehabilitation Medicine*, 32(2), 56-60.
- Lamontagne, A., Richards, C., & Malouin, F. (2000). Coactivation during gait as an adaptive behavior after stroke. *Journal of Electromyography and Kinesiology*, 10(6), 407-415.
- Leamon, T., & Murphy, P. (1995). Occupational slips and falls: more than a trivial problem. *Ergonomics*, 38(3), 487-498.
- Lee, D., & Lishman, J. (1975). Visual proprioceptive control of stance. *Journal of Human Movement Studies*, 1(2), 87-95.

- Lexell, J., Taylor, C., & Sjöström, M. (1988). What is the cause of the ageing atrophy?: Total number, size and proportion of different fiber types studied in whole vastus lateralis muscle from 15- to 83-year-old men. *Journal of the Neurological Sciences*, 84(2-3), 275-294.
- Liu, J., & Lockhart, T. (2006). Comparison of 3D joint moments using local and global inverse dynamics approaches among three different age groups. *Gait & Posture*, 23(4), 480-485.
- Lockhart, T. E. (1997). The ability of elderly people to traverse slippery walking surfaces. *Proceedings of the Human Factors and Ergonomics Society 41st Annual Meeting.*, 41, 125-129.
- Lockhart, T. E. (2000). *Effects of musculoskeletal and sensory degradation due to aging on the biomechanics of slips and falls*. Texas Tech University.
- Lockhart, T. E. (2008). An integrated approach towards identifying age-related mechanisms of slip initiated falls. *Journal of Electromyography and Kinesiology*, 18(2), 205-217.
- Lockhart, T. E., & Kim, S. (2006). Relationship between hamstring activation rate and heel contact velocity: Factors influencing age-related slip-induced falls. *Gait & Posture*, 24(1), 23-34.
- Lockhart, T. E., & Liu, J. (2006). Effects of aging on lower extremity joint torque and muscle activation patterns during slip-induced falls. *Journal of Biomechanics*, 39, S87.
- Lockhart, T. E., Smith, J., & Woldstad, J. (2005). Effects of aging on the biomechanics of slips and falls. *Human factors*, 47(4), 708.
- Lockhart, T. E., Woldstad, J., & Smith, J. (2003). Effects of age-related gait changes on the biomechanics of slips and falls. *Ergonomics*, 46(12), 1136-1160.
- Lord, S. (2006). Visual risk factors for falls in older people. *Age and ageing*, 35(2).
- Lord, S., Dayhew, J., Sc, B., & Howland, A. (2002). Multifocal glasses impair edge-contrast sensitivity and depth perception and increase the risk of falls in older people. *Journal of the American Geriatrics Society*, 50(11), 1760-1766.
- Lord, S., Rogers, M., Howland, A., & Fitzpatrick, R. (1999). Lateral stability, sensorimotor function and falls in older people. *Journal of the American Geriatrics Society*, 47(9), 1077.
- Macaluso, A., & Vito, G. (2004). Muscle strength, power and adaptations to resistance training in older people. *European Journal of Applied Physiology*, 91(4), 450-472.
- Maki, B., & McIlroy, W. (2006). Control of rapid limb movements for balance recovery: age-related changes and implications for fall prevention. *Age and ageing*, 35(2).
- Marigold, D., Bethune, A., & Patla, A. (2003). Role of the unperturbed limb and arms in the reactive recovery response to an unexpected slip during locomotion. *Journal of neurophysiology*, 89(4), 1727.
- Marigold, D., & Patla, A. (2002). Strategies for dynamic stability during locomotion on a slippery surface: effects of prior experience and knowledge. *Journal of neurophysiology*, 88(1), 339.
- Mauritz, K., Dietz, V., & Haller, M. (1980). Balancing as a clinical test in the differential diagnosis of sensory-motor disorders. *British Medical Journal*, 43(5), 407.
- Melville, J., & Watt, D. (1971). Muscular control of landing from unexpected falls in man. *The Journal of Physiology*, 219(3), 729.
- Menz, H., Lord, S., & Fitzpatrick, R. (2003). Age-related differences in walking stability. *Age and ageing*, 32(2), 137.
- Miwa, T., Miwa, Y., & Kanda, K. (1995). Dynamic and static sensitivities of muscle spindle primary endings in aged rats to ramp stretch\* 1. *Neuroscience letters*, 201(2), 179-182.
- Mulch, G., & Petermann, W. (1979). Influence of age on results of vestibular function tests. Review of literature and presentation of caloric test results. *The Annals of otology, rhinology & laryngology. Supplement*, 88(2 Pt 2 Suppl 56), 1-17.
- Nashner, L. (1976). Adapting reflexes controlling the human posture. *Experimental Brain Research*, 26(1), 59-72.
- National Council on Ageing. (2005). *Falls among older adults: risk factors and prevention strategies*. In *Fall free: promoting a national falls prevention action plan.*: J.A. Stevens Eds..

- Neter, J., Kutner, M.H., Nachtsheim, C.J., and Wasserman, W. (1996). *Applied Linear Statistical Models* (3 ed.). Chicago, IL: Irwin.
- Nougier, V., Bard, C., Fleury, M., & Teasdale, N. (1997). Contribution of central and peripheral vision to the regulation of stance. *Gait & Posture*, 5(1), 34-41.
- Oie, K., Kiemel, T., & Jeka, J. (2002). Multisensory fusion: simultaneous re-weighting of vision and touch for the control of human posture. *Cognitive Brain Research*, 14(1), 164-176.
- Okada, S., Hirakawa, K., Takada, Y., & Kinoshita, H. (2001). Age-related differences in postural control in humans in response to a sudden deceleration generated by postural disturbance. *European Journal of Applied Physiology*, 85(1), 10-18.
- Onambélé, G., Narici, M., Rejc, E., & Maganaris, C. (2007). Contribution of calf muscle-tendon properties to single-leg stance ability in the absence of visual feedback in relation to ageing. *Gait & Posture*, 26(3), 343-348.
- Owings, T. M., & Grabiner, M. D. (2004). Step width variability, but not step length variability or step time variability, discriminates gait of healthy young and older adults during treadmill locomotion. *Journal of Biomechanics*, 37(6), 935-938.
- Pai, Y. (2003). Movement termination and stability in standing. *Exercise and sport sciences reviews*, 31(1), 19.
- Pai, Y., & Iqbal, K. (1999). Simulated movement termination for balance recovery: can movement strategies be sought to maintain stability in the presence of slipping or forced sliding? *Journal of Biomechanics*, 32(8), 779-786.
- Pai, Y., Wening, J., Runtz, E., Iqbal, K., & Pavol, M. (2003). Role of feedforward control of movement stability in reducing slip-related balance loss and falls among older adults. *Journal of neurophysiology*, 90(2), 755.
- Pai, Y., Yang, F., Wening, J., & Pavol, M. (2006). Mechanisms of limb collapse following a slip among young and older adults. *Journal of Biomechanics*, 39(12), 2194-2204.
- Parijat, P. (2009). *Preventing Slip-induced Falls in Older Adults: Perturbation Training using a Moveable Platform and Virtual Reality*. Virginia Polytechnic and State University.
- Patla. (1997). Understanding the roles of vision in the control of human locomotion. *Gait & Posture*, 5(1), 54-69.
- Pavol, M., Owings, T., Foley, K., & Grabiner, M. (2000). Mechanisms leading to a fall from an induced trip in healthy older adults. *Journals of Gerontology Series A: Biological and Medical Sciences*, 56(7), 428.
- Pavol, M., & Pai, Y. (2002). Feedforward adaptations are used to compensate for a potential loss of balance. *Experimental Brain Research*, 145(4), 528-538.
- Pavol, M., Runtz, E., & Pai, Y. (2004). Young and older adults exhibit proactive and reactive adaptations to repeated slip exposure. *Journals of Gerontology Series A: Biological and Medical Sciences*, 59(5), M494.
- Perkins, P. (1978). Measurement of slip between the shoe and ground during walking. *Walkway surfaces: Measurement of slip resistance*, 71-87.
- Perkins, P., & Wilson, M. (1983). Slip resistance testing of shoes-New developments. *Ergonomics*, 26, 73-82.
- Perry, C. J. (1992). *Gait analysis: normal and pathological function*: SLACK incorporated.
- Perry, C. J., Kiriella, J. B., Hawkins, K. M., Shanahan, C. J., Moore, A. E., & Gage, W. H. (2010). The effects of anterior load carriage on lower limb gait parameters during obstacle clearance. *Gait & Posture*, 32(1), 57-61.
- Perry, S. (2006). Evaluation of age-related plantar-surface insensitivity and onset age of advanced insensitivity in older adults using vibratory and touch sensation tests. *Neuroscience letters*, 392(1-2), 62.
- Peterka, R. (2002). Sensorimotor integration in human postural control. *Journal of neurophysiology*, 88(3), 1097-1118.

- Peterka, R., & Loughlin, P. (2004). Dynamic regulation of sensorimotor integration in human postural control. *Journal of neurophysiology*, *91*(1), 410.
- Petersen, H., Magnusson, M., Fransson, P., & Johansson, R. (1994). Vestibular disturbance at frequencies above 1 Hz affects human postural control. *Acta oto-laryngologica*, *114*(2), 225-230.
- Porter, M., Vandervoort, A., & Lexell, J. (2007). Aging of human muscle: structure, function and adaptability. *Scandinavian Journal of Medicine & Science in Sports*, *5*(3), 129-142.
- Poulton, E. C., & Poulton, E. (1974). *Tracking skill and manual control*: Academic Press New York.
- Pozzo, T., Levik, Y., & Berthoz, A. (1995). Head and trunk movements in the frontal plane during complex dynamic equilibrium tasks in humans. *Experimental Brain Research*, *106*(2), 327-338.
- Psek, J., & Cafarelli, E. (1993). Behavior of coactive muscles during fatigue. *Journal of Applied Physiology*, *74*(1), 170.
- Pyykko, I., Aalto, H., Hytonen, M., Starck, J., Jantti, P., & Ramsay, H. (1988). Effect of age on postural control. *Posture and Gait: Development, Adaptation and Modulation*. Amsterdam, Netherlands: Elsevier Science Publishers, BV, Biomedical Division, 95-104.
- Pyykko, I., Jantti, P., & Aalto, H. (1990). Postural control in elderly subjects. *Age and ageing*, *19*(3), 215.
- Redfern, Yardley, L., & Bronstein, A. (2001). Visual influences on balance. *Journal of anxiety disorders*, *15*(1-2), 81-94.
- Roberts, T. D. M., & Roberts, T. (1978). *Neurophysiology of postural mechanisms*: Butterworths London.
- Robinovitch, S. N., Chiu, J., Sandler, R., & Liu, Q. (2000). Impact severity in self-initiated sits and falls associates with center-of-gravity excursion during descent. *Journal of Biomechanics*, *33*(7), 863-870.
- Rosenhall, U. (1973). Degenerative patterns in the aging human vestibular neuro-epithelia. *Acta oto-laryngologica*, *76*(1), 208-220.
- Rosenhall, U., & Rubin, W. (1975). Degenerative changes in the human vestibular sensory epithelia. *Acta oto-laryngologica*, *79*(1-2), 67-80.
- Roudsari, B., Ebel, B., Corso, P., Molinari, N., & Koepsell, T. (2005). The acute medical care costs of fall-related injuries among the US older adults. *Injury*, *36*(11), 1316-1322.
- Rubin, G. S., West, S. K., Munoz, B., Bandeen-Roche, K., Zeger, S., Schein, O., et al. (1997). A comprehensive assessment of visual impairment in a population of older Americans. The SEE Study. Salisbury Eye Evaluation Project. *Investigative ophthalmology & visual science*, *38*(3), 557.
- Rudolph, K., Axe, M., Buchanan, T., Scholz, J., & Snyder-Mackler, L. (2001). Dynamic stability in the anterior cruciate ligament deficient knee. *Knee Surgery, Sports Traumatology, Arthroscopy*, *9*(2), 62-71.
- Rudolph, K., Schmitt, L. C., & Lewek, M. D. (2007). Age-Related Changes in Strength, Joint Laxity, and Walking Patterns: Are They Related to Knee Osteoarthritis? *Physical Therapy*, *87*(11), 1422.
- Santello, M., McDonagh, M. J. N., & Challis, J. H. (2001). Visual and non-visual control of landing movements in humans. *The Journal of Physiology*, *537*(1), 313.
- Sattin, R. W., LAMBERT, H., DEBORAH, A., DEVITO, C. A., RODRIGUEZ, J. G., ROS, A., et al. (1990). The incidence of fall injury events among the elderly in a defined population. *American journal of epidemiology*, *131*(6), 1028.
- Schmidt, R., & Lee, T. (2005). *Motor control and learning: A behavioral emphasis*: Human Kinetics Publishers.
- Shadmehr, R., & Mussa-Ivaldi, F. (1994). Adaptive representation of dynamics during learning of a motor task. *Journal of neuroscience*, *14*(5), 3208.
- Sheldon, J. (1963). The effect of age on the control of sway. *Gerontologia clinica*, *5*, 129.
- Sherrington, S. (1906). *The integrative action of the nervous system*: New Haven: Yale University Press.
- Shumway-Cook, A., & Horak, F. (1986). Assessing the influence of sensory interaction on balance: suggestion from the field. *Physical Therapy*, *66*(10), 1548.

- Sicre, A., Leclercq, S., Gaudez, C., GAUTHIER, G., VERCHER, J., & BOURDIN, C. (2008). Modelling Gait Processes as a Combination of Sensory-motor and Cognitive Controls in an Attempt to Describe Accidents on the Level in Occupational Situations. *Industrial health*, 46(1), 3-14.
- Simoneau, M., Teasdale, N., Bourdin, C., Bard, C., Fleury, M., & Nougier, V. (1999). Aging and postural control: postural perturbations caused by changing the visual anchor. *Journal of the American Geriatrics Society*, 47(2), 235.
- Skelton, D., Greig, C., Davies, J., & Young, A. (1994). Strength, power and related functional ability of healthy people aged 65-89 years. *Age and ageing*, 23(5), 371.
- Skinner, H., Barrack, R., & Cook, S. (1984). Age-related decline in proprioception. *Clinical orthopaedics and related research*, 184, 208.
- Spiriduso. (1995). Aging and motor control. In: Lamb DR, Gisolfi CV, Nadel E, editors. *Exercise in older adults* 8.
- Sterling, D., O'Connor, J., & Bonadies, J. (2001). Geriatric falls: injury severity is high and disproportionate to mechanism. *The Journal of trauma*, 50(1), 116.
- Stevens, J., Corso, P., Finkelstein, E., & Miller, T. (2006). The costs of fatal and non-fatal falls among older adults. *Injury Prevention*, 12(5), 290.
- Sundermier, L., & Woollacott, M. (1998). The influence of vision on the automatic postural muscle responses of newly standing and newly walking infants. *Experimental Brain Research*, 120(4), 537-540.
- Sundermier, L., Woollacott, M., Jensen, J., & Moore, S. (1996). Postural sensitivity to visual flow in aging adults with and without balance problems. *JOURNALS OF GERONTOLOGY SERIES A*, 51, 45-52.
- Swash, M., & Fox, K. (1972). The effect of age on human skeletal muscle studies of the morphology and innervation of muscle spindles. *Journal of the Neurological Sciences*, 16(4), 417-432.
- Tang, P., & Woollacott, M. (1998). Inefficient postural responses to unexpected slips during walking in older adults. *The Journals of Gerontology: Series A*, 53(6), M471.
- Tang, P., Woollacott, M., & Chong, R. (1998). Control of reactive balance adjustments in perturbed human walking: roles of proximal and distal postural muscle activity. *Experimental Brain Research*, 119(2), 141-152.
- Teasdale, N., & Simoneau, M. (2001). Attentional demands for postural control: the effects of aging and sensory reintegration. *Gait & Posture*, 14(3), 203-210.
- Teasdale, N., Stelmach, G., Breunig, A., & Meeuwesen, H. (1991). Age differences in visual sensory integration. *Experimental Brain Research*, 85(3), 691-696.
- Thomson, J. A. (1980). How do we use visual information to control locomotion? *Trends in Neurosciences*, 3(10), 247-250.
- Thorpe, S., Fize, D., & Marlot, C. (1996). Speed of processing in the human visual system. *Nature*, 381(6582), 520-522.
- Tinetti, M., & Speechley, M. (1989). Prevention of falls among the elderly (Vol. 320, pp. 1055-1059).
- Torres-Oviedo, G., & Bastian, A. J. (2010). Seeing is believing: effects of visual contextual cues on learning and transfer of locomotor adaptation. *The Journal of neuroscience*, 30(50), 17015.
- Vaughan, C. L., Davis, B. L., & Jeremy, C. O. C. (1992). *Dynamics of human gait*: Human Kinetics Publishers Champaign, Illinois.
- Vereijken, B., van Emmerik, R., Whiting, H., & Newell, K. (1992). Free (z) ing degrees of freedom in skill acquisition. *Journal of motor behavior*, 24(1), 133-142.
- Wade, M. G., Lindquist, R., Taylor, J. R., & Treat-Jacobson, D. (1995). Optical flow, spatial orientation, and the control of posture in the elderly. *The Journals of Gerontology: Series B*, 50(1), P51.
- Warren, W., Kay, B., Zosh, W., Duchon, A., & Sahuc, S. (2001). Optic flow is used to control human walking. *Nature Neuroscience*, 4(2), 213-216.
- Whittle, M. (2002). *Gait analysis: an introduction*: Butterworth-Heinemann Medical.
- Williams, A., & Davids, K. (1998). Visual search strategy, selective attention, and expertise in soccer. *Research Quarterly for Exercise and Sport*, 69(2), 111.

- Williams, A. M., Davids, K., & Williams, J. G. P. (1999). *Visual perception and action in sport*: Taylor & Francis.
- Winter. (1991). *Biomechanics and Motor Control of Human Movement*. New York, NY: John Wiley & Sons Inc.
- Winter, Patla, A., Frank, J., & Walt, S. (1990). Biomechanical walking pattern changes in the fit and healthy elderly. *Physical Therapy*, 70(6), 340.
- Winter, D. A. (1991). *The biomechanics and motor control of human gait: normal, elderly and pathological*: Waterloo Biomechanics.
- Winter, D. A. (1995). Human balance and posture control during standing and walking. *Gait & Posture*, 3(4), 193-214.
- Woollacott, M. (1993). 8 Age-Related Changes in Posture and Movement. *The Journal of Gerontology*, 48(Special Issue), 56.
- Woollacott, M. (2000). Editorial: Systems Contributing to Balance Disorders in Older Adults. *Journals of Gerontology Series A: Biological and Medical Sciences*, 55(8), 424.
- Woollacott, M., Shumway-Cook, A., & Nashner, L. (1986). Aging and Posture Control: Changes in Sensory Organization and Muscular Coordination. *International Journal of Aging and Human Development*, 23(2), 97-114.
- Woollacott, M., & Tang, P. (1997). Balance control during walking in the older adult: research and its implications. *Physical Therapy*, 77(6), 646.
- Yang, J., & Winter, D. (1984). Electromyographic amplitude normalization methods: improving their sensitivity as diagnostic tools in gait analysis. *Archives of Physical Medicine and Rehabilitation*, 65(9), 517.

## Appendix A – PALTO Connection and Location Diagram

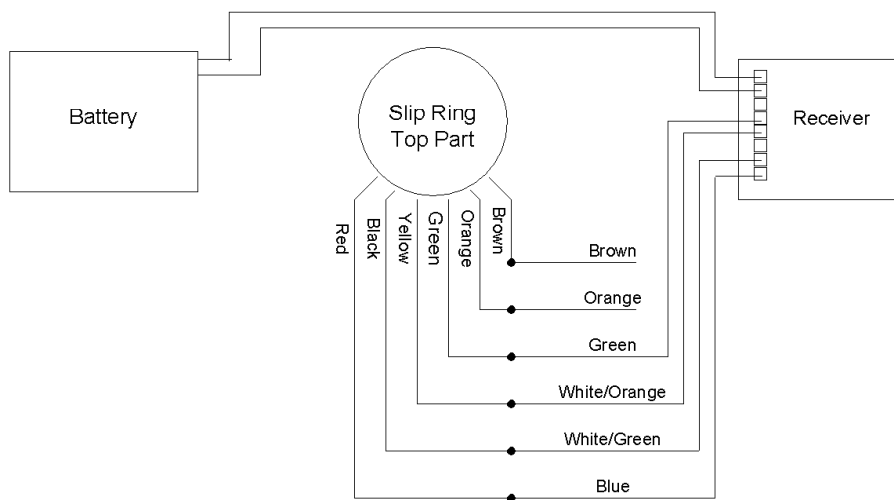
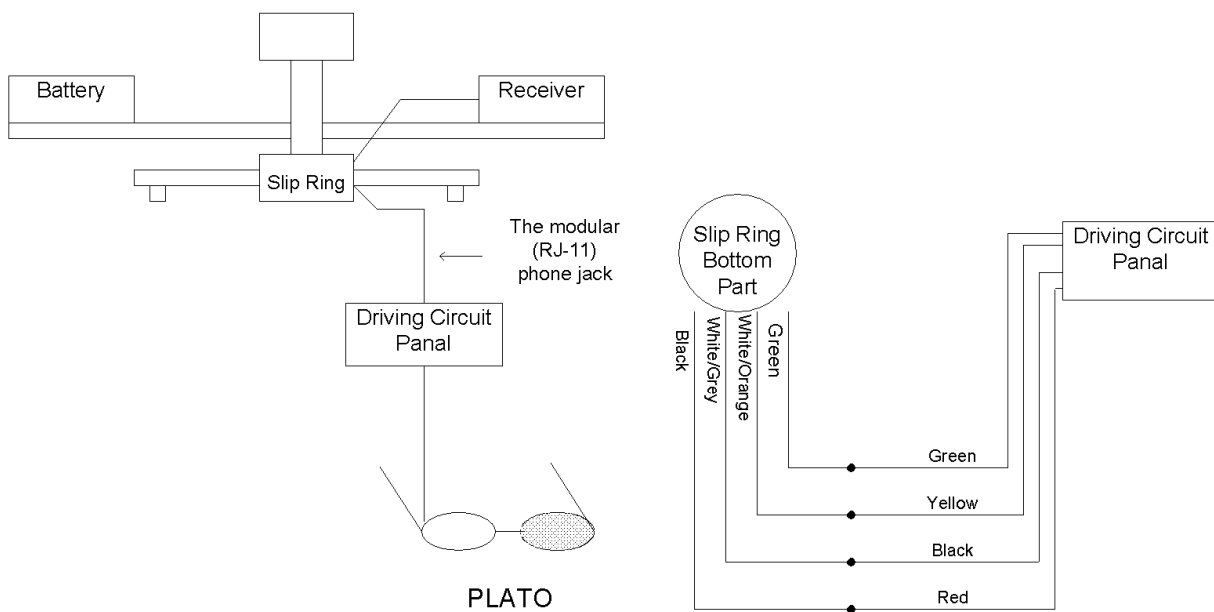

## Appendix B – Medical History Form

### MEDICAL HISTORY AND EMERGENCY CONTACT FORM

**Study Title:** The Age-Related Effects of Visual Input on Kinetic and Kinematic Parameters  
During Unexpected Slip Perturbations

**IRB #:** 10-655

**Date:** \_\_\_\_\_ **Participant Code Number (ID):** \_\_\_\_\_

**Gender:**  Male  Female **Age:** \_\_\_\_\_ **Height (ft/in):** \_\_\_\_\_ **Weight (lb):** \_\_\_\_\_

**Other Study Specific Measurement(s):** \_\_\_\_\_

**IN CASE OF EMERGENCY CONTACT:** **Name:** \_\_\_\_\_ **Phone:** \_\_\_\_\_

#### GENERAL INFORMATION

Do you experience:

Shortness of breath  NO  YES

Dizziness  NO  YES

Headache  NO  YES

Easily fatigued  NO  YES

Pain in arm, shoulder or chest  NO  YES

If Yes was checked, please explain:

Are you currently taking prescription or other medication? If so, please list (e.g., for arthritis, pain, bone loss, high blood pressure, immunosuppression, calcium supplements or Fosamax):

Have you experienced any slips or falls, and if so, how long ago? Please explain:

#### I. BONE AND JOINTS

Have you been diagnosed with osteoporosis (thinning of the bones)?	<input type="checkbox"/> NO	<input type="checkbox"/> YES
--	-----------------------------	------------------------------

Have you experienced fractures of one or more bones in the past 3 years?	<input type="checkbox"/> NO	<input type="checkbox"/> YES
--	-----------------------------	------------------------------



Have you had a DEXA scan (bone scan) done in the past 4 years?	<input type="checkbox"/> NO	<input type="checkbox"/> YES
Have you had hip or knee replacement surgery, or ankle surgery?	<input type="checkbox"/> NO	<input type="checkbox"/> YES
Do you have arthritis in your hands, knees, ankles, etc.?	<input type="checkbox"/> NO	<input type="checkbox"/> YES
Do you have routine back or neck pain?	<input type="checkbox"/> NO	<input type="checkbox"/> YES
Have you had surgery on your spine (back) or neck to relieve pain?	<input type="checkbox"/> NO	<input type="checkbox"/> YES
Have you had knee ligament problems?	<input type="checkbox"/> NO	<input type="checkbox"/> YES
If you had knee problems, was surgery required for treatment?	<input type="checkbox"/> NO	<input type="checkbox"/> YES
Do you have a fallen arch (flat foot) in either of your feet?	<input type="checkbox"/> NO	<input type="checkbox"/> YES
Have you had long-term shoulder pain or surgery on your shoulder?	<input type="checkbox"/> NO	<input type="checkbox"/> YES
<b>II. BRAIN AND NERVOUS SYSTEM</b>		
Have you ever had a stroke?	<input type="checkbox"/> NO	<input type="checkbox"/> YES
If you have had a stroke, has it left you with weakness in an arm or leg?	<input type="checkbox"/> NO	<input type="checkbox"/> YES
Do you have Parkinson's disease?	<input type="checkbox"/> NO	<input type="checkbox"/> YES
If you have Parkinson's disease, does it affect your balance or walking?	<input type="checkbox"/> NO	<input type="checkbox"/> YES
Do you have any inner ear problems causing dizziness or affecting your balance?	<input type="checkbox"/> NO	<input type="checkbox"/> YES
Do you have pinched nerves in your spine affecting walking or sensation in your legs?	<input type="checkbox"/> NO	<input type="checkbox"/> YES
Are you currently taking any medicines that cause you to be dizzy?	<input type="checkbox"/> NO	<input type="checkbox"/> YES
Have you ever had a detached retina in your eye?	<input type="checkbox"/> NO	<input type="checkbox"/> YES
<b>III. MUSCLES</b>		
Do you frequently experience muscle weakness?	<input type="checkbox"/> NO	<input type="checkbox"/> YES
Have you been diagnosed with any muscle wasting disease?	<input type="checkbox"/> NO	<input type="checkbox"/> YES
Have you ever had an inguinal or other hernia?	<input type="checkbox"/> NO	<input type="checkbox"/> YES
If you have had a hernia, was it surgically repaired?	<input type="checkbox"/> NO	<input type="checkbox"/> YES
Do you require a cane or a walker to facilitate your walking?	<input type="checkbox"/> NO	<input type="checkbox"/> YES

<b>IV. HEART AND CIRCULATORY SYSTEM</b>		
Do you tire easily or get out of breath quickly when walking?	<input type="checkbox"/> <b>NO</b>	<input type="checkbox"/> <b>YES</b>
Have you had a heart attack?	<input type="checkbox"/> <b>NO</b>	<input type="checkbox"/> <b>YES</b>
Do you have an enlarged heart or congestive heart failure?	<input type="checkbox"/> <b>NO</b>	<input type="checkbox"/> <b>YES</b>
Do you have an uncorrected or surgically corrected aortic aneurysm?	<input type="checkbox"/> <b>NO</b>	<input type="checkbox"/> <b>YES</b>
Do you have diabetes?	<input type="checkbox"/> <b>NO</b>	<input type="checkbox"/> <b>YES</b>
If you have diabetes, have you been told that you have diabetic neuropathy in your feet (affecting sensation or circulation in your feet)?	<input type="checkbox"/> <b>NO</b>	<input type="checkbox"/> <b>YES</b>
Do you have hemophilia (inability of your blood to clot)?	<input type="checkbox"/> <b>NO</b>	<input type="checkbox"/> <b>YES</b>
Are you taking medicines to thin your blood (e.g., coumadin, heparin)?	<input type="checkbox"/> <b>NO</b>	<input type="checkbox"/> <b>YES</b>
<b>SKIN</b>		
Are you allergic to tape, adhesives, or gels used to attach electrodes to your skin?	<input type="checkbox"/> <b>NO</b>	<input type="checkbox"/> <b>YES</b>
Have you had any allergic reactions to skin creams or disinfectant solutions applied to the skin (e.g., alcohol, iodine)?	<input type="checkbox"/> <b>NO</b>	<input type="checkbox"/> <b>YES</b>

## Appendix C – Vision Screening Tests

Participant's ID \_\_\_\_\_ Gender \_\_\_\_\_ Experiment Date \_\_\_\_\_ Age \_\_\_\_\_

### Acuity Test

#### FAR:

Both eyes: Lens level at FAR, both Occulder swithches at ON, dial on 3 at Green Pilot Light

Both	R	L	T	L	B	L	T	B	T	R	B	R
F-3	1	2	3	4	5	6	7	8	9	10	11	12

Right eye: Lens level at FAR, both Occulder swithches at ON, dial on 4 at Green Pilot Light

Right	B	R	L	B	L	R	L	L	R	T	R	T
F-4	1	2	3	4	5	6	7	8	9	10	11	12

Left eye: Lens level at FAR, both Occulder swithches at ON, dial on 5 at Green Pilot Light

Left	R	B	R	B	T	B	L	L	R	L	T	T
F-5	1	2	3	4	5	6	7	8	9	10	11	12

#### Near:

Both eyes: Lens level at NEAR, both Occulder swithches at ON, dial on 8 at Amber Pilot Light

Both	T	T	R	T	R	T	L	T	R	L	R	B
N-8	1	2	3	4	5	6	7	8	9	10	11	12

Right eye: Lens level at NEAR, both Occulder swithches at ON, dial on 9 at Amber Pilot Light

Right	L	B	L	R	L	R	B	B	T	B	R	L
N-9	1	2	3	4	5	6	7	8	9	10	11	12

Left eye: Lens level at NEAR, both Occulder swithches at ON, dial on 10 at Amber Pilot Light

Left	B	L	B	B	L	R	R	T	R	T	B	L
N-10	1	2	3	4	5	6	7	8	9	10	11	12

## Appendix D – Consent Form

### INFORMED CONSENT FOR PARTICIPANTS IN RESEARCH PROJECTS INVOLVING HUMAN SUBJECTS

**TITLE OF PROJECT:** The Age-Related Effects of Visual Input on Kinetic and Kinematic Parameters During Unexpected Slip Perturbations

**PRINCIPAL INVESTIGATOR:** Thurmon E. Lockhart, PhD, Grado Department of Industrial and Systems Engineering, Virginia Tech

#### I. Purpose

The purpose of this project is to investigate the age-related effects of visual input on the kinetic and kinematic parameters associated with the detection and recovery from slip-induced falls.

#### II. Procedures and Project Information

##### A. Participant Selection

This study will include participants aged 18-30 or 65-85 years old, and free from any restriction of performing daily activities or normal walking. Potential subjects will be screened for past injuries (musculoskeletal, back, knee, and ankle), cardiovascular conditions and eye disease that would prevent them from performing study tasks.

##### B. Time Requirements

The study will require for two separate sessions, each session lasting up to two hours, for a total of four hours to complete the study.

##### C. Study Procedures

###### First session- screening test (45-60 min total)

On the first day, during the consent process, the research staff will describe to the subject what he/she will be doing in the experiment, show them the equipment they will be wearing, and let them walk on the experimental track. The visual occlusion technique will be introduced by using PLATO: Portable Liquid-crystal Apparatus for Tachistoscopic Occlusion. The PLATO provides complete occlusion of both central and peripheral vision when the PLATO is activated ("closed", opaque). When the PLATO is deactivated ("open", transparent), near-complete field-of-view will be provided.

The subject will undergo a general physical examination by the study physician, to review his/her health history form, and to assess the flexibility of his/her joints and range of motion of their limbs. All participants will perform static visual acuity, using the Bausch & Lomb Vision Tester to ensure that participants have normal vision. 20/40 will be required for visual acuity test of both eyes of interested participants in both age groups. If it is determined that the subject has any of the exclusionary criteria, or that he/she has some other pre-existing condition of concern to the physician which would adversely affect the experimental data collection, he/she will be thanked and excused from the study, and will be provided with \$10 compensation for his/her participation to that point.

The subject will then be given an opportunity to walk around the laboratory wearing the safety harness, to allow familiarization with the equipment (e.g., the harness and fall-arresting rig) and the normal floor surface on the “track”. The harness system is designed to protect the subject during the slip and fall experiments. The fall arresting rig will only allow the subject to fall 20cm or less, preventing him/her from falling to the floor. He/she might feel a small jerk in his/her torso as the harness stops his/her fall.

#### Second Session- with a visual input condition (60-90 min total time)

For the second session, after he/she arrives at the lab, the subject will be asked to change his/her clothes in a private change room, where he/she will put on clothes supplied by the lab (e.g., black tank top and shorts). During this session, the subject will wear normal lab supplied shoes (sneakers).

At this time, retro-reflectors will be attached, to the laboratory-supplied clothing that the subject is wearing, over anatomically significant locations on his/her body. Retro-reflectors will be placed over the joints of the ankle, knee, hip, shoulder, elbow and wrist, as well as on the toes of each foot, calf and thigh of the legs, pelvis, and head plus trunk markers over the 10th thoracic and 7th cervical vertebrae and sternum (breastbone) to assess his/her body and joint movements. This will allow the researchers to create computerized stick figure models of the subject's movements during the experiment. To address modesty or cultural concerns, subjects will be given the choice of having someone of the same gender to affix the retro-reflectors to their garments/body.

Eight electrodes will be placed on calf and thigh muscles using to record EMG (muscle activity) data. To address modesty or cultural concerns, subjects will be given the choice of having someone of the same gender to affix the EMG electrodes on his/her body. Additionally, he/she will be asked to wear the liquid crystal display glasses (PLATO). The visual input will be controlled by using the PLATO. The preparation (described above) prior to the first experimental component may take 15-20 minutes.

*First Experimental Component - Baseline (15 minutes)*

Wearing the normal lab shoes, the subject will be asked to walk back and forth along the test “track” for 15 minutes. At both ends of the track, there will be a station where he/she will receive written instructions directing him/her to perform specified filing tasks, e.g., separate 4 blue pieces of paper and file them. He/she will also receive written instructions to look at the TV screen at the opposite end of the track, as he/she is walking to that end, to count the number of dots on the screen of a certain color. When the subject reaches that end of the track, the subject will be asked to tell how many were observed in response to the question. The subject may be supplied with a Walkman audio player during the walking experiment, playing old comedy routines, to conceal any noises associated with laboratory activities. The subject's movements will be monitored/recorded by an infrared camera used to detect movements of the retro-reflectors, so that the researchers can create computerized stick figure models of his/her movements during the experiment. The camera will not yield images from which the subject's likeness would be identified. The subject will be told that if he/she becomes tired during walking, he/she may request to stop and rest. If the subject wishes to withdraw from the study, he/she may request to do so at any time.

*Second Experimental Component – a moveable platform with visual input (30 minutes)*

During the next 30 minutes, at random time points, the researcher will, without the subject's knowledge, create a simulated slip using a moveable platform. Subject may or may not slip, but in case they do, the harness will prevent them from falling. The subjects will be told to react to the balance loss and keep walking on the track as normally as they can. The PLATO will be deactivated (“open”, transparent) to provide visual input. The subjects will be exposed to 10-15 trials of the simulated slips with visual input to allow for practice to recover. The subject will be told that if he/she becomes tired during walking, he/she may request to stop and rest. If the subject wishes to withdraw from the study, he/she may do it at anytime.

*Third Experimental Component- slippery condition with visual input (15 minutes)*

During the next 15 minute session, subjects will conduct similar filing tasks as described above. The PLATO will be deactivated (“open”, transparent) to provide visual input. At one random time point, the researchers will, without the subject's knowledge, create a slippery condition on the track. Subjects will be exposed to a slip perturbation with visual input. Subjects may or may not slip, but as mentioned previously, the harness will prevent them from falling to the floor if they slip. Subjects may experience a jerk in the shoulders and neck as the harness prevents their fall. The subject will be told that if he/she becomes tired during walking, he/she may request to stop and rest. If the subject wishes to withdraw from the study, he/she may request to do so at any time.

At the conclusion of this session, subjects will change back into their personal clothes, and will be paid for their participation in this session.

### Third Session- without a visual input condition (60-90 min total time)

For the third session, subjects will ask to put on clothes and shoes supplied by the lab. All subjects will conduct similar filing tasks as described in the second session. At this time, retro-reflectors and electrodes will be attached at the same position as described in the first session.

Additionally, he/she will be asked to wear the liquid crystal display glasses (PLATO). The visual input will be manipulated by using the PLATO. A reflective tab will be attached at the right shank. A photoelectric reflective sensor will be used to detect the swing phase before the right heel contacts to a moveable platform or slippery surface. A signal from the glasses controller will be sent to the wireless receiver to change the status of the glasses from transparent to opaque to occlude visual input. The preparation (described above) prior to the first experimental component may take 15-20 minutes.

#### First Experimental Component - Baseline (15 minutes)

During the next 15 minute session, subjects will conduct similar filing tasks as described in the first experimental component of the second session.

#### Second Experimental Component – a moveable platform without visual input (30 minutes)

During the next 30 minutes, at random time points, the researcher will, without the subject's knowledge, create a simulated slip using a moveable platform. The PLATO will be activated (“closed”, opaque) to occlude visual input before the heel-contact to the moveable platform. Subject may or may not slip, but in case they do, the harness will prevent them from falling. The subjects will be told to react to the balance loss and keep walking on the track as normally as they can. The subjects will be exposed to 10-15 trials of the simulated slips without visual input to allow for practice to recover. The subject will be told that if he/she becomes tired during walking, he/she may request to stop and rest. If the subject wishes to withdraw from the study, he/she may do it at anytime.

#### Third Experimental Component- a slippery condition without visual input (15 minutes)

During the next 15 minute session, subjects will conduct similar filing tasks as described above. At one random time point, the researchers will, without the subject's knowledge, create a slippery condition on the track. The PLATO will be activated (“closed”, opaque) to occlude visual input before the heel-contact to the slippery condition. Subjects will be exposed to a slip perturbation without visual input. Subjects may or may not slip, but as mentioned previously, the harness will prevent them from falling to the floor if they slip. Subjects may experience a jerk in the shoulders and neck as the harness prevents their fall. The subject will be told that if he/she becomes tired during walking, he/she may request to stop and rest. If the subject wishes to withdraw from the study, he/she may request to do so at any time.

At the conclusion of this session, subjects will change back into their personal clothes, and will be paid for their participation in this session.

At least two laboratory staff members will be present during all testing periods. Staff members running the tests will strongly emphasize, in both spoken and written instructions, that the subject is free to discontinue participation at any time. All lab-supplied garments that subjects will wear will be laundered after each use, with all subjects provided with clean, laundered garments.

### **III. Risks Involved in Participation**

While this study involves the use of safety equipment to prevent contact with the floor during an experimentally induced slip or fall, it does involve more than minimal risk for individuals with bone, joint, or muscle problems. For that reason, individuals with any of the exclusionary criteria have been excluded from the study.

You might encounter the following risks during your participation:

Emotional – You may feel disappointment or self-doubt in not being as agile as when you were at a younger age. You may feel embarrassed at what you perceive as a "poor performance".

Physical – You could experience minor muscle sprain (similar to those encountered in regular daily activities), joint pain (shoulder, knee, ankle), or neck sprain. To minimize injuries, you will be wearing a fall arresting rig and harness system to protect you from any harm caused by slips and falls. Prior to your participation, the harness system will be adjusted to your individual height, ensuring that falls are limited to 7 inches or less limiting the downward and forward progression of your body to reduce physical risks noted above. The experiment will be terminated if one of the following conditions occurs: if you decide to discontinue participation; or, you experience any pain in the back, knees or ankles following walking or slipping. Potential participants will be excluded if bone or joint problems are present that would make participation unsafe or which would compromise the integrity of the research results.

Over 120 human subjects have been tested using the walking surfaces and safety harness, and to date, no injuries have occurred. However, in the event that you are injured while participating in the study, you will be responsible for any expense associated with emergency medical treatment, as neither the researchers nor the University have money set aside for medical treatment expenses.

### **IV. Benefits from Participation**

No direct benefits of participation are promised, however the results of the research may assist in understanding the effect of visual input on detection and recovery from slips and falls. The



results of the study may yield benefits to develop training paradigms to enhance the ability of vestibular and proprioceptive systems during fall recovery.

#### **V. Extent of Anonymity and Confidentiality**

You will be assigned a unique individual code number. The code number will be used on all of your study documents and data files. The Principal Investigator (PI), Dr. Lockhart, will maintain a code key list to link your personal information to the code number used on your data. The code key list will be kept locked in a filing cabinet in the PI's office, and will not be accessible to anyone who is not a project staff member. Coded data will be stored on a computer with password-protected access, and hard copies of data will be kept in a locked filing cabinet in the lab or in the PI's office. At the conclusion of the study, the data will be analyzed, and will be published in scientific journals. You will not be identified in the publications, and your anonymity and confidentiality will be maintained. As required by federal law and Virginia Tech IRB Policy, study records will be maintained for 3 years after the conclusion of the study, after which time they will be destroyed.

Your movements will be monitored/recorded by an infrared camera used to detect movements of the retro-reflectors, so that we can create computerized stick figure models of your movements during the experiment. The camera will not yield images from which your likeness would be identified, only the highlighted white retro-reflectors.

#### **VII. Freedom to Withdraw**

You are free to withdraw from the study at any time and for any reason. Should the researchers determine that you should be removed from the study, you will be thanked and excused, and provided with pro-rated compensation.

#### **VIII. Subject Responsibilities**

You are expected to provide accurate information on your Medical History form. You are expected to adhere to your scheduled participation dates, advising the PI if the date(s) need to be rescheduled, unless you decide to withdraw from the study.

#### **IX. IRB Review of Research**

The Virginia Tech Institutional Review Board (IRB) for Projects Involving Human Subjects, has reviewed this proposed study, and has determined that it is in compliance with federal laws and Virginia Tech policies governing the protection of human subjects in research. However, you should recognize that the review does not constitute an endorsement of the research, and that it is

up to you to determine whether you are willing to participate in the study after having been informed of the risks, benefits, and procedures involved in this study.

**X. Subject / Participant's Permission**

I have read the Consent Form and conditions of this project and have discussed it with the research staff or PI. I have had all my questions answered to my satisfaction. I hereby acknowledge the above and give my voluntary consent to participate in this study:

\_\_\_\_\_ Date: \_\_\_\_\_  
Participant Signature

Participant Project ID Code: \_\_\_\_\_