

**BIRD STRIKE RISK ASSESSMENT
FOR UNITED STATES AIR FORCE AIRFIELDS AND AIRCRAFT**

By

Christine A. Tedrow

Thesis submitted to the Faculty of the
Virginia Polytechnic Institute and State University
in partial fulfillment of the requirements for the degree of

MASTER OF SCIENCE

In

Fisheries and Wildlife Sciences

APPROVAL:

Patrick F. Scanlon, Chair

James A. Parkhurst

Steve L. McMullin

December 1998
Blacksburg, Virginia

Keywords: Birds, Aircraft, Bird strikes, United States Air Force, Risk, Damage

BIRD STRIKE RISK ASSESSMENT
FOR UNITED STATES AIR FORCE AIRFIELDS AND AIRCRAFT

Christine A. Tedrow

Patrick F. Scanlon, Chair

(ABSTRACT)

Analysis of strike data is critical to determine the true economic costs of bird strikes, determine the magnitude of safety issues, and develop preventive measures. Analysis of USAF bird-strike data identified trends and indicated suggested relationships among factors contributing to damaging strikes. From FY 1988 through FY 1997, the annual mean was 2,668 bird strikes with peaks evident in fall and spring. Daylight and dusk were hazardous for bird strikes. More bird strikes occurred during airfield operations - aircraft are at low altitudes and soaring birds are more numerous. Aircraft speed, phase of flight, taxonomic group, bird mass and aircraft group were the strongest predictors of damaging bird strikes. Bird strike rates were calculated for USAF aircraft and selected USAF airfields. Bomber aircraft had the highest strike rate; these aircraft frequently fly long missions at low altitudes where they are likely to encounter birds. Logistic regression analyses estimated odds of occurrence for damaging bird strikes during airfield operations. General statistics, odds for a damaging airfield strike, and airfield strike rates, were used to identify USAF airfields with higher bird strike risks. Howard AFB, Panama, had a higher number and rate of bird strikes, and greater odds for a damaging bird strike than other airfields analyzed.

This study allows recommendations for improving reporting of bird strikes and data management. Results will enable USAF to better estimate bird strike risks aircraft, better focus research on preventing bird strikes, and assess the effectiveness of bird management programs.

ACKNOWLEDGEMENTS

I extend my sincere thanks to my graduate advisor and committee chairman, Dr. Patrick F. Scanlon, for his guidance and friendship. I also thank my committee members Dr. Steve L McMullin and Dr. James A Parkhurst for their advice and inputs.

I greatly appreciate the assistance of the USAF Bird Aircraft Strike Hazard (BASH) Team: Maj. David P. Arrington, Maj. Peter R. Windler, Mr. Eugene LeBoeuf, Lt. Leah Fry, and Lt. Curtis Burney. The BASH Team allowed me to use the USAF bird strike data as the basis of my research and helped me design a project that would produce results useful to the USAF bird-aircraft mishap prevention program.

I owe much thanks to Mrs. D. J. Atkins and Mr. Thomas Schultz at the USAF Safety Center, Kirtland AFB, NM for aircraft flight hours, and MSgt Gary Miller at HQ AFFSA/XAS, Andrews AFB, MD for airfield traffic counts.

I would especially like to thank Dr. Klaus Hinkleman and Dr. Michael Hughes for their statistical support and expertise. I would also like to thank David Bert from the Statistical Counseling Center and Dr. Jim Berkson for their advice in analyzing the strike data.

I also wish to thank Dr. Richard A. Dolbeer, Lt. Col. Russ DeFusco, Mr. Charles D. Lovell, Mr. T. Adam Kelly, and Mr. Ron Merritt for their advice and inputs in this project.

Lastly, I thank my family and friends for their help and encouragement. I would especially like to thank my husband, Capt. Mark Tedrow for his love, patience, and support, without which I would not have endured my graduate work and our time apart.

TABLE OF CONTENTS

ABSTRACT	ii
ACKNOWLEDGEMENTS	iv
TABLE OF CONTENTS	v
LIST OF TABLES	vii
LIST OF FIGURES.....	xi
INTRODUCTION.....	1
THE BIRD STRIKE PROBLEM	1
The History of Bird Strikes	1
Competition for Space	1
Increased Engine Susceptibility and Aircraft Speeds	2
Bird Population Growth	3
Habitat Adaptations of Bird Species	5
A Problem That Will Continue	6
REDUCING THE BIRD STRIKE RISK	7
Bird Management Programs	7
Bird Avoidance	10
Designing Aircraft Engines and Transparencies to Withstand Bird Impacts	11
Bird Strike Data Collection and Analysis and Its Role in Aircraft Safety	13
OBJECTIVES	14
CHAPTER 1: ANALYSES OF THE USAF BIRD STRIKE DATABASE.....	16
INTRODUCTION	17
METHODS	19
RESULTS	23
TABLES AND FIGURES	31
DISCUSSION	72
SUMMARY.....	76

CHAPTER 2: AIRCRAFT AND AIRFIELD RISK ASSESSMENTS	77
INTRODUCTION	78
METHODS	80
RESULTS	83
TABLES AND FIGURES	86
DISCUSSION	115
SUMMARY	119
GENERAL DISCUSSION AND SUMMARY	121
RECOMMENDATIONS	124
LITERATURE CITED	130
APPENDIX A DESCRIPTION OF USAF BIRD STRIKE DATA VARIABLES	135
APPENDIX B USAF AIRCRAFT ENGINE FIGURES	146
APPENDIX C GLOSSARY OF USAF TERMINOLOGY.....	148
VITA	153

LIST OF TABLES

Table 1.1	Interactions between independent variables contributing to USAF bird strikes with aircraft damage (DAMAGE) as the dependent variable.....	31
Table 1.2	Interactions between independent variables contributing to USAF bird strikes with bird group (GROUP) as the dependent variable.....	32
Table 1.3	Damaging (\geq \$10,000) and non-damaging ($<$ \$10,000) USAF bird strikes by year for FY 1988-1997.....	33
Table 1.4	Damaging (\geq \$10,000) and non-damaging ($<$ \$10,000) USAF bird strikes by month for FY 1988-1997.....	34
Table 1.5	Damaging (\geq \$10,000) and non-damaging ($<$ \$10,000) USAF bird strikes by time of day (as reported by USAF personnel) for FY 1988-1997	35
Table 1.6	Damaging (\geq \$10,000) and non-damaging ($<$ \$10,000) USAF bird strikes by aircraft phase of flight for FY 1988-1997	36
Table 1.7	Damaging (\geq \$10,000) and non-damaging ($<$ \$10,000) USAF bird strikes by aircraft group for FY 1988-1997	37
Table 1.8	USAF bird strikes during airfield and low level/range operations by aircraft group for FY 1988-1997.....	38
Table 1.9	Damaging (\geq \$10,000) and non-damaging ($<$ \$10,000) USAF bird strikes by aircraft impact point for FY 1988-1997	39
Table 1.10	Damaging (\geq \$10,000) and non-damaging ($<$ \$10,000) USAF bird strikes by aircraft speed (KIAS) for FY 1988-1997	40
Table 1.11	USAF bird strikes during airfield and low level/range operations by aircraft speed (KIAS) for FY 1988-1997	41
Table 1.12	Damaging (\geq \$10,000) and non-damaging ($<$ \$10,000) USAF bird strikes by aircraft altitude (ft AGL) for FY 1988-1997.....	42
Table 1.13	Damaging (\geq \$10,000) and non-damaging ($<$ \$10,000) USAF bird strikes by bird group for FY 1988-1997.....	43
Table 1.14	USAF bird strikes during airfield and low level/range operations by bird group for FY 1988-1997	44

Table 1.15	Damaging (\geq \$10,000) and non-damaging ($<$ \$10,000) USAF bird strikes by bird size for FY 1988-1997	45
Table 1.16	Damaging (\geq \$10,000) and non-damaging ($<$ \$10,000) USAF bird strikes by region for FY 1988-1997.....	46
Table 1.17	Relative risks, based on FY 1988-1997 USAF bird strike data, of damaging bird strikes for bird groups	47
Table 1.18	Relative risks, based on FY 1988-1997 USAF bird strike data, of damaging bird strikes for bird sizes	48
Table 1.19	Relative risks, based on FY 1988-1997 USAF bird strike data, of striking bird groups with landing lights on.....	49
Table 1.20	Relative risks, based on FY 1988-1997 USAF bird strike data, of damaging bird strikes for impact points.....	50
Table 1.21	Relative risks, based on FY 1988-1997 USAF bird strike data, of damaging bird strikes for times of day.....	51
Table 1.22	Relative risks, based on FY 1988-1997 USAF bird strike data, of damaging bird strikes for phases of flight.....	52
Table 1.23	Relative risks, based on FY 1988-1997 USAF bird strike data, of damaging bird strikes for regions of the world.	53
Table 2.1	Damaging (\geq \$10,000) and non-damaging ($<$ \$10,000) USAF bird strikes during airfield operations by aircraft group for FY 1994-1997	86
Table 2.2	Damaging (\geq \$10,000) and non-damaging ($<$ \$10,000) USAF bird strikes during airfield operations by aircraft for FY 1994-1997.....	87
Table 2.3	USAF aircraft group bird strike rates (per 10,000 flight hours) for FY 1994-1997.....	88
Table 2.4	USAF aircraft type bird strike rates (per 10,000 flight hours) for FY 1994-1997	89
Table 2.5	Airfield movements by USAF airfield for FY 1994-1997.....	90
Table 2.6	Damaging (\geq \$10,000) and non-damaging ($<$ \$10,000) USAF bird strikes during airfield operations by USAF airfield for FY 1994-1997	91
Table 2.7	Percentage of USAF bird strikes each month for USAF airfields for FY 1994-1997.....	92

Table 2.8	USAF airfield bird strike rates (per 10,000 airfield movements) for FY 1994-1997.....	93
Table 2.9	Odds of damage ratios, based on FY 1994-1997 USAF bird strikes, for Cargo/airlift/transport aircraft and USAF airfields with bird strike rates ≥ 2.00	94
Table 2.10	Odds of damage ratios, based on FY 1994-1997 USAF bird strikes, for Cargo/airlift/transport aircraft and USAF airfields with bird strike rates < 2.00 and ≥ 1.00	95
Table 2.11	Odds of damage ratios, based on FY 1994-1997 USAF bird strikes, for Cargo/airlift/transport aircraft and USAF airfields with bird strike rates < 1.00	96
Table 2.12	Odds of damage ratios, based on FY 1994-1997 USAF bird strikes, for Fighter/attack aircraft and USAF airfields with bird strike rates ≥ 2.00	97
Table 2.13	Odds of damage ratios, based on FY 1994-1997 USAF bird strikes, for Fighter/attack aircraft and USAF airfields with bird strike rates < 2.00 and ≥ 1.00	98
Table 2.14	Odds of damage ratios, based on FY 1994-1997 USAF bird strikes, for Fighter/attack aircraft and USAF airfields with bird strike rates < 1.00	99
Table 2.15	Odds of damage ratios, based on FY 1994-1997 USAF bird strikes, for Trainer aircraft and USAF airfields with bird strike rates ≥ 2.00	100
Table 2.16	Odds of damage ratios, based on FY 1994-1997 USAF bird strikes, for Trainer aircraft and USAF airfields with bird strike rates < 2.00 and ≥ 1.00	101
Table 2.17	Odds of damage ratios, based on FY 1994-1997 USAF bird strikes, for Trainer aircraft and USAF airfields with bird strike rates < 1.00	102
Table 2.18	Odds of damage ratios, based on FY 1994-1997 USAF bird strikes, for Bomber aircraft and USAF airfields with bird strike rates ≥ 2.00	103
Table 2.19	Odds of damage ratios, based on FY 1994-1997 USAF bird strikes, for Bomber aircraft and USAF airfields with bird strike rates < 2.00 and ≥ 1.00	104
Table 2.20	Odds of damage ratios, based on FY 1994-1997 USAF bird strikes, for Bomber aircraft and USAF airfields with bird strike rates < 1.00	105

Table 2.21	Odds of damage ratios, based on FY 1994-1997 USAF bird strikes, for Reconnaissance aircraft and USAF airfields with bird strike rates ≥ 2.00	106
Table 2.22	Odds of damage ratios, based on FY 1994-1997 USAF bird strikes, for Reconnaissance aircraft and USAF bases with bird strike rates < 2.00 and ≥ 1.00	107
Table 2.23	Odds of damage ratios, based on FY 1994-1997 USAF bird strikes, for Reconnaissance aircraft and USAF airfields with bird strike rates < 1.00	108
Table 2.24	The odds of damage, at different aircraft speeds, resulting from bird strikes during airfield operations involving bomber aircraft and “medium” birds at Barksdale AFB, LA.....	109
Table 2.25	The odds of damage resulting from bird strikes, involving different sized birds, during airfield operations involving trainer aircraft at 0-50 KIAS at Randolph AFB, TX.....	110
Table 2.26	The odds of damage resulting from bird strikes during airfield operations involving different aircraft at > 300 KIAS and “large” birds at Shaw AFB, SC.....	111
Table 2.27	The odds of damage resulting from bird strikes during airfield operations involving fighter aircraft at 151-200 KIAS and “medium” birds at different USAF airfields.....	112
Table 2.28	Comparison between mean bird strike rates and odds of damage resulting from bird strikes during airfield operations involving fighter aircraft at 151-200 KIAS and “medium” birds at different USAF airfields.....	113

LIST OF FIGURES

Figure 1.1	USAF bird strikes by year for FY 1988-1997.....	54
Figure 1.2	USAF bird strike costs by year for FY 1988-1997	55
Figure 1.3	USAF damaging bird strikes by year for FY 1988-1997	56
Figure 1.4	USAF damaging bird strike costs by year for FY 1988-1997.....	57
Figure 1.5	USAF mean bird strikes by Julian date for FY 1988-1997.....	58
Figure 1.6	USAF bird strikes by month for FY 1988-1997	59
Figure 1.7	USAF mean bird strikes by hour for FY 1988-1997.....	60
Figure 1.8	USAF bird strikes by time of day for FY 1988-1997	61
Figure 1.9	USAF bird strikes per hour by time of day for FY 1988-1997	62
Figure 1.10	USAF bird strikes by phase of flight for FY 1988-1997.....	63
Figure 1.11	USAF bird strike costs by phase of flight for FY 1988-1997	64
Figure 1.12	USAF bird strikes by aircraft group for FY 1988-1997.....	65
Figure 1.13	USAF bird strike costs by aircraft group FY 1988-1997	66
Figure 1.14	USAF bird strikes by point of impact on aircraft for FY 1988-1997.....	67
Figure 1.15	USAF costs per bird strike by aircraft speed for FY 1988-1997	68
Figure 1.16	USAF bird strikes by aircraft altitude FY 1988-1997.....	69
Figure 1.17	USAF bird strikes by bird group for FY 1988-1997.....	70
Figure 1.18	USAF bird strike costs by bird group for FY 1988-1997	71
Figure 2.1	Map of USAF airfields selected for analyses.....	114

INTRODUCTION

THE BIRD STRIKE PROBLEM

The History of Bird Strikes

Since the beginning of powered flight, collisions have been occurring between aircraft and birds (Solman 1978, Richardson 1994, Thorpe 1996). The first recorded bird-aircraft collision, now more commonly called a “bird strike”, occurred on 3 April 1912 when a Model EX Wright Pusher flown by Calbraith Rogers off the coast of California, struck a California gull (*Larus californicus*). The gull became entangled in the control wires and caused the plane to crash, killing Rogers (Solman 1978, Steenblik 1997). Since then, bird strikes have damaged aircraft and even resulted in destroyed aircraft and the loss of aircrew members. In fact, aircraft encounters with birds have grown more frequent, costly, and deadly with time. Factors contributing to the bird strike problem include the increase in the number of aircraft competing with birds for space, the increase in engine susceptibility to bird damage, the increase in many bird populations, and the adaptation of many bird species to urban and other altered environments (Solman 1978, 1981; Donoghue 1996).

Competition for Space

The number of aircraft competing with birds for space has increased dramatically since the early days of flight when aircraft and aircraft operations were less numerous. In 1997, commercial aircraft flew over 40 billion hours (NTSB 1998), and these numbers can be expected to double about every 4 to 5 years (Langley 1993). In addition, military aviation is in no way declining. With current demands on today’s peacekeeping and wartime military contingencies, military aircraft numbers and flight hours most likely will increase. The United States Air Force (USAF) alone flew approximately 2 million

hours in fiscal year 1997 (USAF Safety Center 1998). Given these data, it is clear that the potential for a bird strike most certainly will persist and may increase.

Increased Engine Susceptibility and Aircraft Speeds

Prior to the introduction of turbine aircraft engines (see Appendix B and C for USAF aircraft figures and terminology), the occurrence of bird strikes to both military and civilian aircraft were infrequent, the costs to repair damage were low, and the number of lives lost was low. Piston engines are more robust than today's turbine engines and therefore better able to withstand impacts with birds. In addition, piston engines have a rotating exterior propeller that usually prevents birds from entering the engine where major damage can occur. In short, piston engines are less prone to ingestion of birds and the damage associated with it than are today's turbine engines.

Fundamental engine design changes led to the development of modern turbine engines. Engine power and efficiency, and thus aircraft performance and capabilities, increased with the advent of turbine engines, but the hazard of bird-aircraft collisions also increased. Turbine engines have small parts that revolve at high speeds and thus are more fragile than piston engines. In addition, high bird strike rates today may be attributed to the turbine engine's greater frontal area, greater intake area, and higher air intake per unit of time than that of piston engines (Solman 1971). One could argue that in large diameter turbine engines, a single "small" bird is likely to be ejected with the bypass flow, which would spare the core unless fan blades disintegrate. However, with their greater surface area, turbine aircraft engines are vulnerable to multiple bird strikes (Donoghue 1996).

An increase in bird-related mishaps also may be attributed to the high flight speeds attained by aircraft with turbine engines. High aircraft speed prevents birds from escaping the path of an aircraft because the birds are unable to quickly evaluate the aircraft's approach speed and take appropriate evasive actions. In addition, bird strikes that occur at high aircraft speed produce greater damage than those that occur at low aircraft speed do. For example, a 4-lb. (1.81-kg) bird struck by an aircraft flying at 260 knots indicated air speed (KIAS) or 480 km/h will exert a force of approximately 15 tons

(13.64 tonnes) to a 6-inch (15.2-cm) diameter impact point on the aircraft. When aircraft speed is doubled, the force of the impact will be 4 times greater (Solman 1973).

Although bird strikes can occur during all phases of flight, the risk of a catastrophic incident (loss of aircraft and/or aircrew lives) is greatest when aircraft are flying at high speeds and low-altitudes. Current USAF mission emphasis on low-altitude, high-speed training flights significantly has increased aircrew vulnerability to catastrophic bird strike mishaps. Aircraft usually operate at altitudes from 50 to 300 m above ground and at 350 to 600 KIAS (463 to 1,112 km/h) during low-level flight (DeFusco 1993). Low-altitude, high-speed flight exposes aircraft to greater numbers and species of birds than high altitude flight and the odds of a damaging bird strike occurring are elevated under such flight conditions. In these incidents, radomes, pitot tubes, and wings may incur substantial damage. Tail structures may be dented, torn, or punctured. Engine damage may include bent or broken rotor blades and/or blocked engine air intakes; sometimes complete, uncontained engine failure results from a bird strike. Windscreens also are a major concern. Penetration of the windscreen by a bird almost always leads to injury or death of the pilot.

Bird Population Growth

Populations and distributions of bird species that typically cause problems on airfields and for aircraft have increased. The changes in populations and distributions of some of these bird species are discussed below.

Populations of several large bird species, high in the food chain (e.g., pelicans, gulls, and other predatory birds) have increased greatly since the banning and control of chlorinated hydrocarbons (e.g., DDT) during the 1970's (Lovell and Stella 1997). In addition, state and federal wildlife agencies and various private organizations have helped implement environmental laws that have protected wildlife sanctuaries, wetlands, and other environments used by these birds. These environments provide food for birds throughout the winter, and thus have contributed to the success of birds such as Canada geese (*Branta canadensis*) (Donoghue 1996). The growing North American populations

of large, flocking bird species such as Canada geese have contributed to the bird strike problem.

Flocking species such as swallows (*Hirundinidae*), starlings (*Sturnus vulgaris*), and blackbirds (*Icteridae*), and gulls (*Larus* spp.) present a persistent seasonal hazard on airfields. Though small, swallows present a hazard because they forage in the air, feeding on insects just above the airfield. Construction of anthropogenic structures (e.g., highway bridges) which satisfy ecological requirements (e.g., nesting), have enabled swallows to increase their populations and to expand their ranges in North America (Krzysik 1987). Blackbird populations and distributions have increased at least partly as a result of deforestation, the increase in ecotones (edges), and the large-scale habitat changes humans have made in the landscape, particularly the increase in grain crops (Krzysik 1987). In the past, availability of winter food source has been the limiting factor on blackbird population growth in certain areas of North America. However, agricultural fields and livestock pens provide an adequate and predictable supply of grain today. The populations and distributions of starlings also have increased due to starlings' adaptability to human induced landscape change (Krzysik 1987). Starlings, often found with blackbirds in dense flocks on or near airfields, are "feathered bullets", having a high body density relative to other problem birds such as herring gulls (*Larus argentatus*) (Dolbeer 1997). The population of gulls in certain areas of North America also has shown strong growth. In the Great Lakes region, the gull population – primarily ring-billed gulls (*Larus delawarensis*) – has increased 20-fold in 40 years (Donoghue 1996). Gulls are a potential strike problem when their flight paths to and from large communal roosts or landfills cross airfields (Smith 1986).

Because a bird's weight and the speed of the aircraft affect the force of the impact, large birds are the greatest threat to aircraft (Wright 1997). Hawks (*Buteo* spp.), eagles (*Accipitridae*), storks (*Ciconiidae*), and vultures (*Cathartidae*) are soaring and gliding birds that use thermals as aids in flight (Jarmen 1993). Of these birds, a single vulture presents the greatest threat to an aircraft. In North America, vultures geographically are numerous and distributed widely. The North American Breeding Bird Survey (BBS) data show an increase of 1.1% per year ($P = 0.02$) for turkey vultures (*Cathartes aura*) from 1966-1993 (Peterjohn et al. 1994, Lovell 1997a). Vultures also

are a threat to aircraft because they have a large body mass (>2 kg), and often soar and migrate at the same altitude at which military flight operations occur (DeFusco 1993).

Other large flocking birds also are becoming a serious problem to aircraft. BBS population data from 1966-1993 show an increase of 3.1% per year for American white pelicans (*Pelecanus erythrorhynchos*) (Peterjohn et al. 1994, Dolbeer 1997). The mid-continent snow goose (*Chen caerulescens*) population also is increasing at an alarming rate; numbers now exceed 4 million birds, compared to <1 million in the late 1960s (Blohm 1998). And from 1985 to 1995 the North American Canada goose population increased from 2.8 million to 4.7 million (Donoghue 1996).

Habitat Adaptations of Bird Species

The population increases in all bird species is not necessarily a problem for aircraft, but increases in certain species coupled with their adaptation to altered environments magnify the risk of collision for aircraft. For example, changes in the Canada goose population have been of great concern. Not only has the number of geese increased in North America, but the distribution of wintering geese has changed over the last 40 years as well. The number of migratory Canada geese actually has decreased from 118,000 to 29,000 pairs in only 7 years, with a drop of over 60,000 pairs since 1993 (Donoghue 1996). Concurrently, the number of resident Canada geese (i.e., those that have ceased to migrate and are now living year-round in urban areas) has increased noticeably. In 1970, the North American resident Canada goose population was estimated to be 0.2 million birds. From 1970 to 1985 the population tripled in size. This population again tripled in size (from 600,000 to 1.8 million birds) from 1985 to 1995 (Donoghue 1996, Dolbeer 1997).

Migration patterns of Canada geese are not as clear as they once were and many flocks are staying in traditional northern wintering grounds year-round. Resident Canada geese have become increasingly successful at adapting to the ever-changing human landscape, including such areas as golf courses, parks, and airfields. Like golf courses and parks, airfields are attractive to geese because of the presence of water and grassy

expanses devoid of trees and shrubs. The increase in the number of geese in the vicinity of airports presents a greater risk to aviation safety (MacKinnon 1996*b*).

A Problem That Will Continue

As populations of selected North American bird species grow and as they adapt to urban environments, the potential for a bird strike escalates. Additionally, growth in aircraft operations and changes in aircraft engine performance has set the stage for a greater chance of collisions between aircraft and birds (Wright 1997). This is reflected in the USAF data on bird strikes.

The USAF has reported an average of 2,500 bird strikes annually since 1985. Although the number of damaging (\geq \$10,000, by definition) bird strikes have been relatively small compared to the total number of bird strikes and the total number for aircraft flying hours or airfield movements, the losses still are significant. Since 1985, bird strike mishaps have caused approximately \$500 million in damage to USAF aircraft, have destroyed 5 aircraft, and have resulted in the deaths of 33 crewmembers.

As long as aircraft compete with birds for airspace, there will continue to be a chance of collision. Despite the fact that the bird strike problem can not be eliminated, airfield and safety personnel and aircraft engine and transparency manufacturers can work together to reduce the risk of bird hazards to aircraft operations. Specifically, these risks can be minimized with active bird management programs, bird avoidance, aircraft engine and transparency design, and collection and analysis of data on bird strikes.

REDUCING THE BIRD STRIKE RISK

Bird Management Programs

Between 75-90% of all bird strikes occur on or near airfields, primarily during take-off and landing operations (Blokpoel 1976). This is due partly to the fact that, during airfield operations, aircraft are flying at low altitudes where the density of birds typically is greatest. The high bird strike rate on and near airfields also is due to the attractiveness of airfields to birds and other wildlife. Airfields typically are located away from human habitations on large, flat expanses of land where there is high visibility. Areas immediately adjacent to airfields often include agricultural lands, bodies of water, industrial food processing plants, sanitary landfills, and garbage dumps. As a result, airfields and surrounding areas commonly have diverse habitats that offer food, water, and cover for many species of birds and mammals.

Food is a bird attractant that often is abundant on airfields. Short-grass (<7 in., <17.8 cm) areas provide tender grass, seeds, and clovers for flocking birds. In addition, birds can feed on insects and their larvae when grasses are short. Earthworms forced to the ground surface (and often onto pavements) in heavy rains are a good food-source for gulls. Small birds and mammals on airfields attract large predatory birds. These predatory birds, which present a great hazard to aircraft because of their size, use stakes, poles, signs, and even runway lights on airfields as perches while they hunt for prey (Burger 1983). Areas immediately adjacent to airfields also may attract birds. In particular, landfills and garbage dumps located adjacent to airfields provide food for soaring, scavenging birds such as gulls. Agricultural crops growing adjacent to airfields attract insects that attract flocking birds such as swallows and swifts. The crops themselves (and crop residues) also serve as a food for other small flocking passerines such as blackbirds (Blokpoel 1976, Burger 1983).

Water for drinking, bathing, and loafing also attracts birds to airfields. In addition, water sources on airfields are attractive to many bird species for protection and feeding. Impenetrable pavements (e.g., runways and taxiways, roads, parking areas), rooftops, and the flat, low-lying nature of airfields present challenges to airfield personnel

in being able to drain collected surface water. Poor maintenance of drainage ditches may allow pooling of water to occur and create attractive, temporary water sources for birds. Ponds built for aesthetic purposes on airfields also attract birds (Blokpoel 1976). In addition, wetlands present on airfields are a problem for airfield personnel; wetlands are protected under sections of the Clean Water Act and cannot be filled without mitigation.

Cover or shelter, a third bird attractant, is offered by natural vegetation such as shrubs, hedges, trees, high grass, and to some extent open water on airfields. Airfields often have dense stands of trees that are used by starling and blackbird flocks for night roosting. Some architectural features in hangers and other buildings also provide shelter (Burger 1983).

Unfortunately, there is no swift or simple solution to airfields' bird strike problem. Robert A. Jantzen, former director of the U.S. Fish & Wildlife Service, stated "As long as man competes with birds for airspace, there will be the danger of collisions. The trick is to avoid having them compete for the same space at the same time and to reduce the attractiveness of airports to birds" (Klinger 1982:2). An active airfield bird management program that takes direct action to manipulate the birds can decrease greatly the attractiveness of an airfield to birds and have a tremendous impact on the number of bird strikes. Bird management programs encompass habitat management and the implementation of bird-dispersal techniques to discourage birds from remaining on and/or near airfields.

Habitat management, in the context of airfield management and bird strike prevention, is the modification of the environment to reduce the availability of food, water, and cover/shelter on airfields to make them less attractive to birds or their prey. Habitat management techniques include the reduction of food sources by spraying insecticides and herbicides on airfield grasses. Mowing airfield grasses to a height of 7-14 in. (18-36 cm.) is recommended to help reduce the number of small rodents that attract predatory birds and to discourage flocking birds from loafing and feeding at airfields.

The removal of trees also decreases the attractiveness of airfields to birds; horticultural trees provide food such as nuts, seeds, and fruits for birds and small rodents. The reduction of open water on airfields also can help reduce the number of birds on or

near airfields. Airfields have constraints, however. Environmental regulations concerning wetland mitigation, for instance, must be heeded.

The use of cultural or mechanical means to eliminate natural cover provided by dense tree stands and buildings also are habitat management techniques. Additional techniques to reduce the number of birds on airfields include the relocation of garbage dumps, proper management of sanitary landfills, and construction or modification of buildings to provide as little potential shelter as possible.

Bird-dispersal techniques are designed to harass or frighten birds so that they leave airfields. Well-accepted and commonly used bird-dispersal techniques include use of trained falcons, pyrotechnic devices, loud noises, and bird distress calls. These techniques can be successful, however, they must be varied to avoid habituation by birds. Lethal means of bird control, though viewed as a last resort, often are necessary to enhance the effectiveness of dispersal techniques (Blokpoel 1976, Burger 1983). Active bird management, including both habitat management and bird-dispersal techniques, can aid in the prevention of bird strikes by reducing the population of birds that present an immediate hazard to aircraft on airfields.

Aviation personnel awareness is an integral part of bird management and the prevention of bird strikes. Aviation personnel must be aware of potential problems that birds present to aircraft. It is only with awareness that aviation personnel can play an integral part in bird management programs aimed at reducing the number of bird-related mishaps. To illustrate this point, consider the most recent, high-profile damaging bird strike involving USAF aircraft. On 22 September 1995, a modified Boeing 707 USAF E-3B Advance Warning and Control System (AWACS) aircraft, while taking off from Elmendorf AFB, Alaska, struck approximately 30 Canada geese, averaging 6 lbs. (2.7 kg) each. The number 1 engine ingested at least 1 goose and sustained immediate, severe damage that induced uncorrectable compressor stalls. The number 2 engine ingested 3 geese and sustained catastrophic damage leading to an uncontained fan failure. Having ingested geese in two of its four engines, the AWACS was unable to sustain flight and crashed approximately 15-km northeast of the base. All 24 military personnel aboard the aircraft were killed. In addition to the tragic loss of life, this catastrophic incident cost the USAF \$89 million (USAF Safety Center 1995, MacKinnon 1996a, Wright 1997).

Following this incident, the USAF placed an increased emphasis on safety and bird strike reporting and prevention. Currently within the USAF, there is greater awareness of the hazards birds present to aircraft. Accordingly, USAF personnel at bases are implementing better bird management programs and are reporting bird strike incidents with more accuracy and efficiency. Furthermore, the increased effort by airfield personnel has resulted in an increase in the number of microscopic feather portions and whole feathers being sent to the Smithsonian for identification (Dove 1996). As is evident through this E-3 bird strike incident, aviation personnel awareness about bird strikes and management techniques is critical to bird strike prevention.

Bird Avoidance

Bird avoidance is another means of preventing bird strikes. In the 1980s, the first USAF Bird Avoidance Model (BAM) was developed to help reduce bird strikes to aircraft through use of historical data, areas and times of elevated bird activity that pose potential hazards to aircraft are identified (Lovell 1997). The original BAM incorporated waterfowl and raptor species that account for the majority of damaging bird strikes to military aircraft. However, since its development populations and distributions of many of these bird species have increased. As previously discussed factors contributing to these increases include restrictions on the use of pesticides and other chemicals that negatively affected many bird species, enhanced management and protection programs, and adaptation by some bird species to human environments (Dwyer et al. 1996). Since development of the first BAM, modeling technology has improved greatly. The Geographic Information Systems (GIS) used today in modeling are effective at analyzing multiple layers of information sequentially and/or simultaneously and synthesizing new output maps with appropriate parameters highlighted (Aronoff 1993).

The improved modeling capabilities and the changes in populations and distributions of many bird species involved in aircraft mishaps compelled the USAF to develop a new BAM, which was completed in May 1998. This revised BAM incorporates thirty years of bird distribution and population data. Data for 50 species of birds, derived from well over 4,000 surveys (e.g., CBC and BBS), were correlated with

remotely-sensed and ground-sampled environmental data (e.g., geographic factors, physiographic factors, and climatic factors sampled from meteorological monitoring stations) and used to produce a raster-based GIS BAM designed to predict bird distributions and abundance for the continental United States. Data sets within the model are normalized by bird weight so that a single relative risk is represented for each 1-km. block of the contiguous United States for 26 periods of the year and 4 daily time periods (Burney 1998). Flight planners and aircrews can use this new BAM to generate a risk surface for a given low-level training route, military operating area (MOA), airfield, or any other location at a designated date and time. This allows them to identify and choose flights that reduce the exposure of aircraft to birds and thus minimize the potential for bird strikes to their aircraft.

Designing Aircraft Engines and Transparencies to Withstand Bird Impacts

Because aircraft and birds will always share the sky, aircraft must be designed to resist the impact of a collision with a bird. “Industry moves to minimize the danger through tougher designs – especially in engines and windscreens – has improved the chances of surviving encounters with a few birds” (Donoghue 1996:55). Turbine engines used on aircraft undergo demanding tests to demonstrate their capability to ingest birds and continue to produce thrust. Though there are USAF specifications for testing and design with respect to the bird strike problem, the specifications serve as guidance rather than as requirements and are tailored by engine manufacturers to meet requirements dictated by military aircraft roles and missions. In general, the USAF “guidelines” call for testing against “small”, “medium”, and “large” birds. Specifications relating to ingestion of “small” birds require that engines recover and allow aircraft to complete the mission after ingesting up to 16 2- to 4-oz. (56.7- to 113.4-g.) birds at one time, depending on the size of the engines’ inlet. Specifications relating to the ingestion of “medium” birds call for engines to keep operating after ingesting several (*sic*) 1.5-lb. (0.68-kg) birds at one time, again depending on the size of the engines’ inlet. Specifications relating to the ingestion of “large” birds require that engines be able to

ingest a single 4-lb. (1.81-kg) bird, shut down safely, and contain any damage within the engine housing (GAO 1989).

These specifications may be inadequate. A 1988 study of data on bird strikes to USAF aircraft by the Aeronautical Systems Division of the Air Force System's Command concluded that the size and number of "medium" birds involved in collisions differ from what is used in military aircraft engine testing. Studies showed that the average size of "medium" birds being ingested is 2.5 lbs. (1.13 kg), rather than the 1.5-lb. test size specified by the USAF (GAO 1989). In addition, given the large numbers of birds involved in strikes that weigh over 4 lbs. (1.81 kg), the requirements for large birds also may be inadequate. Future guidelines most likely will include single birds up to 8.0 lbs. (3.63 kg) and multiple 1.5- to 2.5-lb. (0.68- to 1.13-kg) birds. These requirements, as in the past, would differ from engine to engine based on inlet area.

Bird strikes to windscreens, canopies, and other parts of aircraft transparencies also are hazardous to aircraft. As with engines, design requirements differ for various aircraft with different missions. For example, cargo/airlift/transport aircraft do not fly missions that require sudden changes in velocity or altitude as exist for most military aircraft. These aircraft therefore may be at less risk of incurring a damaging bird strike than most tactical military aircraft, and consequently require less stringent windscreen specifications with respect to the bird strike hazard. On the other hand, bomber aircraft fly longer, farther low-level operations and more night missions than do fighter/attack aircraft and, as indicated in a 1990 study by Merritt and Short (1993), this exposes them to heavier birds. In general, the current USAF guideline for aircraft flying low-level operations is for the windscreen to survive a collision with a 4-lb. (1.81-kg) bird at a maximum level flight speed; for tactical (fighter and attack) aircraft, that speed is 500 KIAS or 926 km/h (GAO 1989).

Despite these design criteria, aircraft engines and transparencies still are not bird-proof. Large birds such as Canada geese can weigh well over 4 lbs. (3 to 12 lbs., 1.36 to 5.44 kg). In addition, large dense flocks of blackbirds, starlings, gulls, and geese often are encountered on airfields and occasionally are struck during take-off and landing; at high altitudes, aircraft have struck migrating flocks of waterfowl. Flocks may be quite

dense and birds may not be distributed evenly within the flocks; hence, >1 bird often is struck by an aircraft.

Even the most robust engines will fail to produce thrust under extreme circumstances (Solman 1973, Lewis 1995). When birds are ingested in an engine, fan-blades can be bent or broken, which then destroys other engine components and ultimately causes engine failure and/or destruction of the aircraft. Certainly, the most catastrophic military example is the 1995 Elmendorf E-3 bird strike. The TP-33 P100 E-3 engines were designed and put into operation before present engine bird damage requirements were implemented. Yet, deficient engine design was not cited as a factor in the Elmendorf mishap (USAF Safety Center 1995). Modern engines may have provided additional protection against such bird strikes, but the outcome most likely would have been the same - it is impossible to make an aircraft bird-proof. Manufacturers certainly will continue to improve engines' and transparencies' abilities to withstand bird impacts, but this can only help minimize damage (Donoghue 1996).

Bird Strike Data Collection and Analysis and Its Role in Aircraft Safety

The collection and analysis of data on bird strikes are critical to determining the economic costs of bird strikes, the magnitude of safety issues, and the nature of strike problems so that future strikes can be prevented (Cleary et al. 1997). Analysis of historical data on bird strikes can be used to identify airfields with high bird strike risks and to estimate the odds of a damaging bird strike incident to aircraft and airfields. In addition, analyses of these data can reveal what species of birds are problematic, when and where strikes frequently occur, and other significant factors that enable airfield and safety personnel to better apply management and research efforts toward preventing bird strikes. Analysis of data on bird strikes also can be useful to engine and windscreen manufacturers. When manufacturers have an understanding of the sizes and weights of birds involved in strikes, it is possible for them to assess quantitatively how strong engine components and windscreens need to be to withstand bird impacts. Manufacturers then can use this information to improve their engines to withstand future strikes (MacKinnon 1996b). The collection and analysis of data on bird strikes can identify factors that

directly or indirectly lead to bird strike incidents. When the bird strike problem is understood, appropriate measures can be taken to prevent future collisions and decrease the likelihood of damage that results from collisions.

OBJECTIVES

The USAF Bird Aircraft Strike Hazard (BASH) Team has been collecting data on bird strikes since 1974. Although these data are summarized frequently, an extensive analysis has not yet been performed. The overall objective of my research is to assess the risk of bird strikes in the USAF. Thorough analysis of historical data on bird strikes within the USAF will identify trends in bird strikes involving USAF aircraft and suggest important relationships among factors that contribute to damaging strikes. Furthermore, it will provide estimates of the odds of occurrence for damaging bird strikes to USAF aircraft during airfield operations at select USAF bases in the continental United States. Bird strike rates (number of bird strikes per 10,000 aircraft movements or flight hours) will be calculated for USAF aircraft and selected (based on airfield movement totals) USAF airfields in the continental United States. The odds of damage will be compared among USAF bases with similar bird strike rates.

These analyses can help the USAF BASH team better focus USAF management and research efforts aimed at preventing bird strikes. Specifically, comparison of bird strike rates will identify airfields and aircraft with bird strike problems. Further comparisons among airfields with similar strike rates will identify high-risk airfields with respect to damage. The BASH Team and airfield personnel can use the findings of my study to determine the effectiveness of bird management programs. If an airfield's bird strike rate increases and/or its odds of damage are high (relative to other airfields with similar environmental conditions and/or strike rates), then the airfield's bird management program would need to be re-examined (Burger 1983). Moreover, information obtained from analysis of the strike data may be useful in future improvements of the USAF Bird Avoidance Model (BAM); airfield's bird strike rates and calculated odds of damage could improve the model's assessment of the bird strike risk in some areas of the United States. Finally, analyses in my study may reveal shortcomings in USAF data collection

processes useful in assessing the bird strike problem; identification of these shortcomings can lead to improvement in the reporting and collection of data on future USAF bird strikes, aircraft flight hours, and airfield movement counts. Results of these analyses will enable the USAF to better estimate the magnitude and nature of the bird strike problem to USAF aircraft.

CHAPTER 1

ANALYSES OF THE USAF BIRD STRIKE DATABASE

INTRODUCTION

Section 7 of the USAF mishap reporting instruction AFI 91-202 requires that all USAF installations report both damaging (\geq \$10,000 and/or loss of life) and non-damaging ($<$ \$10,000) bird and other wildlife related mishaps (bird strikes) involving military and civilian aircraft at USAF installations. This instruction also requires the reporting of USAF aircraft bird strikes at Navy, Army, and Civilian airfields. From fiscal year (FY) 1974 through FY 1997, maintenance and safety personnel at each installation reported bird strikes to the USAF BASH Team on AF Form 853 (see Appendix A). Information recorded on the form included date of strike, time of day, geographic location (airfield), phase of flight, type of aircraft, aircraft speed and altitude, aircraft path with respect to clouds, whether aircraft landing and strobe lights were on, point of impact of wildlife with the aircraft, amount of monetary damage, and (when known) identity of species struck and average species weight.

When possible, bird remains were collected from damaged aircraft by base personnel and sent to the Smithsonian Museum of Natural History for identification by their personnel (Ms. Roxie Laybourne and Ms. Carla Dove). Identification of birds from feather fragments involved comparison of microscopic and whole feather characters to museum specimens as well as consideration of circumstantial evidence (e.g., locality, date, time of strike) pertaining to the sample (Dove 1996). Personnel at the Smithsonian reported to the BASH Team the species struck and the average weights of these species. For the period of FY 1988 through FY 1997, remains from approximately 25% of all USAF strikes ($n = 26,679$) - including bird and other wildlife - were identified by Smithsonian personnel. Remains were not recovered and/or identified for approximately 71% of all USAF strikes ($n = 26,679$).

The BASH Team received 45,965 reports of bird strikes involving USAF aircraft from FY 1974 through FY 1997. Analyses in my study were limited to USAF bird strikes occurring from FY 1988 through FY 1997 for 3 reasons. First, data on bird strikes during this period are more complete (i.e. fewer missing values) and uniform than data on earlier bird strikes; there are fewer unknowns, and the number of strikes reported each year was relatively constant ($\bar{x} = 2,668$, $SE = 86.9$, $SD = 275.03$). Second, as previously

discussed, bird numbers (for many species) and aircraft activities have been greater in the last decade. Hence, the number of bird strikes between FY 1988 and FY 1997 are more representative of the problem today. And third, strikes during the period of FY 1988 through FY 1997 occurred at bases and to aircraft important to the USAF today. Data on bird strikes prior to 1988 included once active bases that have been closed in the last decade (e.g., Williams AFB, AZ) and/or aircraft that have been retired or are no longer flown as frequently (e.g., F-4). In addition, some of the aircraft in use today (e.g., B-2 and C-17 aircraft) were not in the USAF inventory or flown often prior to 1988.

Limiting my analyses to USAF bird strikes between FY 1988 and FY 1997 reduced the sample size for my study to 26,679 bird strikes. The **objectives** of this portion of my study were to:

1. Identify and describe statistically significant variables and interactions of variables that contribute to damaging bird strikes,
2. Describe general USAF bird strike trends over the period of FY 1988-1997,
3. Determine, with respect to damage, the relative risks associated with categories of statistically significant variables that contribute to damaging bird strike incidents.

METHODS

Data Preparation

Before I performed any analyses of the data on bird strikes, I used Microsoft Access 97 (Microsoft Corporation 1996) to identify and correct clerical errors and invalid information in each bird strike record. If I was not able to correct an error, I deleted only the information in the affected field - not the entire strike record. For example, if reported data simply were misspelled, then they were corrected. If, on the other hand, reported data were invalid (e.g., illogical or infeasible latitude and longitude) and could not be ascertained from additional information (e.g., description of location and phase of flight), then I deleted the invalid data. I corrected approximately 90% of the detected errors.

In addition to those strike records with deleted values because correct information could not be ascertained, I found many other bird strike records where information on ≥ 1 variable was missing. In some cases, “unknowns” most likely resulted from a strike not being detected until maintenance crews performed a post-flight inspection. Pilots can fail to notice an impact unless the bird is large or they can hear the impact. In other cases, all data on bird strikes were not reported. It is important to note that the Statistical Package for Social Sciences (SPSS 8.0) program (SPSS Inc. 1998) I used to perform statistical procedures eliminated a bird strike record from analyses when any values (of variables being analyzed) were missing. Hence, the actual sample size for each analysis varied with respect to the variables included in the given analysis. When all USAF bird strikes for the period of FY 1988 through FY 1997 were included in analyses, sample sizes ranged from 2,645 to 26,679 bird strike records.

After I reviewed and corrected the database on reported strikes, I then entered it as a SPSS 8.0 database. Variables in the bird strike database predominantly are categorical. I assigned specific numbers to categories of these variables. Strike date and damage were entered as both categorical and continuous variables. Initially, I considered a few variables (i.e., aircraft altitude, aircraft speed, and bird weight) to be continuous in GLM General Factorial analyses, but subsequent tests for linear trends on these

continuous data were performed using scatter plots (Bohrnstedt and Knoke 1994, SPSS Inc. 1998). Because I did not observe linear trends, these continuous data were re-coded into categorical variables and specific numbers were assigned to categories of these variables. It is important to note that for all analyses including the species struck, only strikes involving birds were analyzed. Analyses involving other variables included bird and other wildlife strikes. All variables used in analyses are listed and described in Appendix A.

Factorial Analysis

To estimate the magnitude of the USAF bird strike problem, it was necessary to identify factors (and interactions of factors) associated with USAF damaging bird strikes. I performed a series of factorial experiments to determine the factors or variables statistically significant with respect to damage resulting from bird strikes. Using the SPSS GLM General Factorial procedure (SPSS Inc. 1998), I observed main effects of all independent variables for the dependent variable “damage.” Damage was entered as a continuous variable in these analyses. The following variables were entered as independent variables: bird group, bird weight, time of day, aircraft group, aircraft altitude, aircraft speed, impact point on the aircraft, aircraft path with respect to clouds, landing lights on, strobe lights on/off, month, phase of flight, and region of the world. Because data on strikes were unbalanced, Type III sums of squares were used to evaluate hypotheses. I considered a probability value (P) < 0.05 to be statistically significant.

The SPSS GLM General Factorial procedure (SPSS Inc. 1998) also was used to examine main effects of all independent variables for the dependent variable bird group. The independent variables in previous analyses again were used except that bird group was replaced with damage as an independent variable. Damage was entered as a categorical variable in these analyses. Again, Type III sums of squares were used to evaluate hypotheses, and a probability value (P) < 0.05 was considered to be statistically significant.

Independent variables that were not significant with respect to the dependent variables (damage and bird group) were eliminated from further analyses. I then

observed dependent variables at two-factor level combinations of the remaining independent variables. Again, Type III sums of squares were used to evaluate hypotheses, and a probability value (P) < 0.05 was considered to be statistically significant.

General Statistics

I performed calculations of simple descriptive statistics such as means and measures of variability with categorical variables determined to be statistically significant using the GLM General Factorial procedure (SPSS Inc. 1998). I then made comparisons of categories of the dependent variable “damage” and independent variables using the SPSS Crosstabs procedure (SPSS Inc. 1998). In contingency tables where >20% of cells had expected values <5, where possible I collapsed related categories within variables to increase the expected values in cells. For example, four categories of damage were originally designated, but these later were collapsed into 2 categories (<\$10,000 and ≥\$10,000 and/or loss of life) to increase the expected values in cells. For these inferential tests, I considered a probability value (P) < 0.05 to be statistically significant.

Adjusted residuals produced in cross-sectional analyses were used to measure the relative strength of the relationship between the dependent variable “damage” and the independent variables and also to identify specific cells (i.e., categories of the independent variables) that departed markedly from the model of independence. Adjusted residuals are standardized estimates of the difference between an observed count and that cell’s expected value. Typically, values >2.0 or <-2.0 suggest statistical importance (SPSS Inc. 1998).

I then used Microsoft Access 97 to summarize the bird strike data (Microsoft Corporation 1996). The summaries and the results from cross-sectional analyses were used to discern general trends in data on USAF bird strikes from FY 1988 through FY 1997.

Estimation of Relative Risk of Damage

I re-coded independent variables (e.g., aircraft group) into dichotomous (dummy) variables. As in prior analyses, I made comparisons of the independent variables with respect to damage using the SPSS Crosstabs procedure (SPSS Inc. 1998). Fisher's two-tailed exact test was used to determine significance ($P < 0.05$). Fisher's is a test for 2 x 2 contingency tables that calculates exact probabilities of obtaining the observed results if the 2 variables are independent and the marginals are fixed at their observed values. It is useful in cases such as this where sample size and expected values are small. As a measure of association, I computed relative risk ratios. The relative risk ratio is a commonly used index that measures the strength of the association between the presence of a factor and occurrence of an event. Relative risk is estimated as the ratio of 2 incidence rates (SPSS Inc. 1993). Relative risk ratios served as a check for adjusted residuals.

RESULTS

Factorial Analysis

Variables found to be associated ($P < 0.05$) with incidence of damage included bird group ($n = 7,640$, $P < 0.001$), bird weight ($n = 6,039$, $P < 0.001$), time of day ($n = 22,690$, $P < 0.001$), aircraft group ($n = 26,210$, $P < 0.001$), aircraft altitude ($n = 21,959$, $P = 0.001$), aircraft speed ($n = 22,162$, $P < 0.001$), impact point on the aircraft ($n = 26,638$, $P < 0.001$), landing lights on ($n = 20,879$, $P < 0.001$), month ($n = 26,555$, $P < 0.001$), phase of flight ($n = 19,351$, $P < 0.001$), and region of the world ($n = 16,890$, $P < 0.001$).

Interactions of these independent variables observed for the dependent variable damage are listed in Table 1.1. With respect to damage, interactions between aircraft speed and all variables were significant ($P < 0.05$). All interactions with impact point were significant ($P < 0.05$) as well. Interactions between aircraft group and all variables except time of day ($P = 0.637$) and aircraft altitude ($P = 0.872$) were significant ($P < 0.05$). Interactions between bird group and all variables except region ($P = 0.390$) and aircraft altitude ($P = 0.063$) were significant ($P < 0.05$). Interactions between region and aircraft altitude ($P < 0.001$), phase of flight ($P < 0.001$), time of day ($P < 0.001$), and month ($P < 0.001$) were significant. Interaction between region and landing lights on, however, was not significant ($P = 0.144$). Interactions between month and aircraft altitude ($P < 0.001$) and phase of flight ($P < 0.001$) were significant.

The variables found to be associated ($P < 0.05$) with bird group included damage ($n = 7,640$, $P < 0.001$), time of day ($n = 6,589$, $P < 0.001$), aircraft group ($n = 7,531$, $P < 0.001$), aircraft speed ($n = 6,651$, $P < 0.001$), impact point on the aircraft ($n = 7,277$, $P < 0.001$), aircraft path with respect to clouds ($n = 4,947$, $P = 0.001$), landing lights on ($n = 6076$, $P < 0.001$), month ($n = 7,701$, $P = 0.048$), phase of flight ($n = 5,890$, $P < 0.001$), and region of the world ($n = 5,518$, $P < 0.001$).

Interactions of these independent variables observed for the dependent variable bird group are listed in Table 1.2. With respect to bird group, interaction between region and aircraft group ($P < 0.001$), month ($P < 0.001$), time of day ($P = 0.019$), phase of flight, and aircraft speed ($P = 0.021$) were significant. Interactions between landing lights

on and time of day ($P = 0.005$) and aircraft group ($P = 0.014$) also were significant. In addition, interaction between month and aircraft group was significant ($P = 0.013$) and interaction between phase of flight and time of day was significant ($P = 0.024$). All other interactions were not significant with respect to bird group.

General statistics

From FY 1988 through FY 1997, 26,679 bird strikes were reported to the USAF BASH Team. During this period, the mean annual number of strikes was 2,668 (SE = 86.9, Figure 1.1) and bird strikes cost the USAF >\$209 million in damages, with a mean annual cost of \$14.5 million (95% CI \$8-26.6 million) (Table 1.3, Figure 1.1 and 1.2). Only 4.0% of all reported bird strikes to USAF aircraft resulted in aircraft damage \geq \$10,000.

Occurrence of bird strikes peaked in May and again in October. Thirty-eight percent ($n = 26,556$) of bird strikes occurred from August through October and 21.3% occurred in April and May (Figure 1.6). The mean percentage of damaging strikes per month was 4.5% (range 2.8-6.9) (Table 1.4). The percentage of damaging strikes that occurred during the winter months differed from the mean ($P < 0.05$, 95% CI 3.6-5.4%) with the largest percentage of damaging strikes occurring in November (5.7%, $Res_{adj} = 4.0$), December (5.8%, $Res_{adj} = 3.0$), January (6.3%, $Res_{adj} = 3.8$), and February (6.8%, $Res_{adj} = 4.7$). Fewer damaging bird strikes occurred from May-October ($Res_{adj} < 0.0$).

With respect to bird strikes by time of day as reported by aircrews, bird strikes were most numerous during the day (65.5%, $n = 22,691$), followed by night (29.6%), dusk (3.9%), and dawn (0.9%) (Table 1.5 and Figure 1.8). The mean percentage of damaging strikes across all time of day categories was 3.3%; no categories of the variable significantly differed ($P < 0.05$, 95% CI 1.8-4.8%) from this mean (Table 1.5). However, by another analysis measure (adjusted residuals), more damaging strikes occurred during the day than during other time periods ($Res_{adj} = 7.1$). In addition, approximately 70% of all reported bird strikes occurred when the sky was clear.

The percentage of strike for each time of day is more accurately depicted when hours per time of day is considered. Strikes per hour were calculated using an average

day and night length of 11.25 hours and an average dawn and dusk length of 0.75 hours, each (Cleary et al. 1998). This analysis showed that bird strikes are more numerous during the day (38.8%), but that dusk and dawn were periods of greater bird strike risk (34.9% and 8.7%, respectively) than was shown when hours per time of day was not considered (Table 1.5 and Figure 1.9).

My initial analysis of the data on bird strikes revealed that phase of flight was unrecorded in 27% of all reports ($n = 26,679$). These involved bird strikes when pilots did not know or report the phase of flight (and possibly other pertinent information) or bird strikes that were not realized until post-flight maintenance inspections. In cases where phase of flight was known ($n = 19,352$), 23.4% percent of USAF reported bird strikes occurred on ranges and low-level operations. These strikes accounted for approximately 22% of the reported damage to USAF aircraft (\$191 million) and 44.3% ($n = 941$) of the damaging strikes to USAF aircraft. Over one-half (66.2%, $n = 19,352$) of the bird strikes occurred on or near airfields during take-off, landing, touch-and-go, or final approach, or while in the traffic pattern. Strikes that occurred during landing, take-off, and touch-and-go accounted for 62.3% of all reported damage. However, excluding the 1995 Elmendorf mishap, strikes that occurred during landing, take-off, and touch-and-go accounted for only 35.5% of reported damage. Only 10.4% of strikes occurred during climb-out, descent, or cruise (Figures 1.10 and 1.11). Among phases of flight, the mean percentage of damaging to total strikes was 5.9% (95% CI 2.9-8.7). Significantly ($P < 0.05$) greater proportions of damaging to total strikes occurred during low-level (8.9%, $Res_{adj} = 14.1$) and range (15.5%, $Res_{adj} = 6.9$) operations (Table 1.6).

Analysis of strikes by aircraft group revealed that cargo/airlift/transport aircraft incurred the most bird strikes (44.2%, $n = 26,168$), but strikes to these aircraft typically did not result in damage ($Res_{adj} = -11.5$). Despite the large number of strikes to cargo/airlift/transport aircraft, these aircraft accounted for only 10.4% of all reported damage resulting from bird strikes. An estimated 25.1% of the bird strikes occurred to fighter/attack aircraft, 16.4% occurred to trainer aircraft, 8.3% occurred to bomber aircraft and only 5.0% occurred to reconnaissance aircraft. Due largely to a single bird strike incident (1995 Elmendorf E-3 strike), reconnaissance aircraft incurred the greatest amount of damage (40.8%). However, adjusted residuals for this group ($Res_{adj} = -1.0$)

did not suggest statistical importance with respect to damage. An estimated 38.6% of all damage resulted from bird strikes involving fighter/attack aircraft. Less than 10.0% of all damage was incurred by trainer and bomber aircraft (Figures 1.12 and 1.13). The mean percentage of damaging to total strikes for aircraft groups was 4.3% (range 2.4-7.6) (Table 1.7). Although strikes to fighter/attack aircraft were more likely to result in damage than most other aircraft groups ($Res_{adj} = 6.8$), the percentage of damaging to total strikes for bomber aircraft (7.6%, $Res_{adj} = 8.9$) was significantly greater than the mean ($P < 0.05$, 95% CI 2.2-6.4). Both fighter/attack aircraft and bomber aircraft experienced more damaging strikes during low level/range operations. Other aircraft groups experienced more damaging strikes during airfield operations (Table 1.8)

Analysis of strikes by point of impact revealed that 17.7% of bird strikes where impact point was known ($n = 25,639$) involved engine ingestions, 21.9% involved the wings, 20% involved the radome/nose, and 12.3% involved the fuselage/antenna/skin. The windshield/canopy was impacted in 16.2% of reported strikes, but only 0.1% of all bird strikes resulted in windshield penetration. About 34.2% of all windshield penetrations resulted in damage $\geq \$10,000$ (Table 1.9). The percentage of damaging to total strikes involving windshield penetration was much greater than the mean (6.9%) for all impact points ($P < 0.05$, 95% CI 2.4-11.3%). Windscreen penetrations accounted for 5.2% of the overall damage where point of impact was specified. Strikes involving engines were more likely than most impact points to result in damage (engine ingestion, 10.0%, $Res_{adj} = 21.1$; outside engine, 7.0%, $Res_{adj} = 4.9$). About 81% of all damage was attributed to strikes that involved engines (Figure 1.14).

Approximately 18% of bird strikes ($n = 22,163$) occurred at 0-50 KIAS, 5.4% of strikes occurred at 51-100 KIAS, 29.4% of strikes occurred at 101-150 KIAS, 21.3% of strikes occurred at 151-200 KIAS, 11.2% of strikes occurred at 201-250 KIAS, 3.8% of strikes occurred at 251-300 KIAS, and 10.8% occurred at speeds greater than 300 KIAS. In general, bird strikes at speeds < 200 KIAS were less likely to result in damage ($Res_{adj} < 0$), however, the percentage of damaging to total bird strikes increased with aircraft speed (Figure 1.15, Tables 1.10 and 1.11). Although there was an increase in the percentage of damaging to total bird strikes as speed increased, only the percentage for speeds > 300 KIAS departed markedly from the mean (4.9%, $P < 0.05$, 95% CI 1.5-8.4, $Res_{adj} = 18.8$).

Only 2% (n = 21,957) of all reported bird strikes to USAF aircraft occurred above 3,000 ft. above ground level (AGL). The majority (94%) of strikes occurred at or below 2,000 ft. AGL (Figure 1.16). When analyzed in 500 ft. AGL increments, the mean percentage of damaging to total bird strikes was 4.9% (95%CI 3.65-6.23). Bird strikes from 501-1,000 ft. AGL and from 1,001-1,500 ft. AGL were more likely to be damaging than non-damaging ($Res_{adj} = 4.4$ and $Res_{adj} = 2.3$, respectively). However, only the 3,001-3,500 ft. AGL increment had a significantly ($P < 0.05$) greater percentage of damaging to total strikes than the mean (9.4%, $Res_{adj} = 2.5$) (Table 1.12).

Some knowledge of bird species involved was available in 28.6% (7,641) of bird strikes involving USAF aircraft (Figures 1.17 and 1.18). The identification standard ranged from detailed examination by Smithsonian personnel of recovered bird remains to the simple glance of a pilot. Bird species frequently involved in strikes included horned larks (*Eremophila alpestris*, 645), meadowlarks (*Sturnella* sp., 315), mourning doves (*Zenaida macroura*, 270), turkey vultures (266), barn swallows (*Hirundo rustica*, 217), red-tailed hawks (*Buteo jamaicensis*, 177), American robins (*Turdus pilaris*, 162), killdeer (*Charadrius vociferus*, 147), and European starlings (141). Most of these species rarely caused much damage to aircraft. Problem species in terms of the number of damaging strikes to aircraft included turkey vultures (76), and red-tailed hawks (39), black vultures (*Coragyps atratus*, 26), Canada geese (17), and herring gulls (16), mallard (*Anas platyrhynchos*, 12), snow geese (12), and horned larks (11).

Raptors, as a group, were struck most often (17.8%), were struck more often during low level/range operations, and were more likely than other bird groups to cause damage to USAF aircraft ($Res_{adj} = 13.9$); an estimated 16.4% of the raptor strikes were damaging (Tables 1.13 and 1.14). Although strikes involving blackbirds and starlings (10.5%) and gulls (10.1%) were numerous particularly during airfield operations, collisions with blackbirds and starlings typically did not result in damage (2.0%, $Res_{adj} = -5.0$), whereas 9.4% ($Res_{adj} = 3.0$) of collisions with gulls did. Geese and swans were struck infrequently (1.2%), as were pelicans (0.29%). However, 41% ($Res_{adj} = 13.1$) of the goose and swan strikes and 31.8% ($Res_{adj} = 4.6$) of the pelican strikes were damaging. A relatively high number of strikes involved horned larks (8.4%), yet these strikes rarely (1.7%, $Res_{adj} = -4.8$) caused damage to aircraft.

The greatest number of strikes involved small birds ($n = 3,317$), followed by small-medium birds ($n = 1,047$), and medium birds ($n = 605$). The fewest number of strikes involved large birds ($n = 600$), yet a greater percentage these strikes were damaging (29.1%) compared to strikes involving smaller birds (Table 1.15).

The largest number of bird strikes to USAF aircraft has occurred in the conterminous United States and in Europe ($n = 16,891$; 84.6% and 7.2%, respectively). Bird strikes in these regions were most likely to result in damage ($Res_{adj} = 2.2$ and $Res_{adj} = 3.0$, respectively). A larger percentage of strikes in Europe (23.1%) were damaging than that in the conterminous United States (4.9%). In the conterminous United States, the greatest number of bird strikes occurred in the southeast region (8,477), followed by the southwest region (3,087), the northeast region (1,775), and the northwest region (951). The northwest region had the largest percentage of damaging to total strikes (6.6%), followed by the southwest region (5.7%), the southeast region (4.7%), and the northeast region (3.5%, Table 1.16). Bird strikes in the northwest and southwest regions ($Res_{adj} = 2.7$ and $Res_{adj} = 2.4$, respectively) were more likely to result in damage than were bird strikes in the northeast ($Res_{adj} = -2.4$).

Relative Risks

Fighter/attack, bomber, and trainer aircraft had relative risks of damage greater than 1.0. Bombers had the highest relative risk of damage (2.066). Cargo/airlift/transport aircraft had a relative risk of 0.466. The risk of damage was not significant ($P = 0.071$) for reconnaissance aircraft.

Aircraft speed plays an important role in determining the outcome of a bird-aircraft collision. Bird strikes that occur at aircraft speeds ≤ 300 KIAS (≤ 556 km/h) had a relative risk of damage considerably < 1.0 (0.266, $P < 0.001$). Bird strikes at flight speeds > 300 KIAS (> 556 km/h) were roughly 3.8 times more likely ($P < 0.001$) to result in damage.

The species and weight of bird involved in a strike determine the outcome of a bird-aircraft collision. For the most part, relative risks increased with increasing bird weight (Table 1.18). For example, relative risks for goose, raptor, duck, and pelican

strikes all were high (>2.0). Relative risks of damage for gulls and waders were 1.5 and 1.8, respectively. Bird strikes involving blackbirds and starlings, doves, horned larks, American robins, and shorebirds had no associated increased risks. Owl strikes and crow and raven strikes had relatively low risks that were not statistically significant ($P > 0.05$) (Table 1.17).

Whether landing lights were on was significant with respect to damage ($P < 0.001$). Cross-tabulation analysis comparing bird groups with landing lights on revealed some interesting associations. Relative risks associated with blackbirds and starlings, crows and ravens, ducks, geese, horned larks, pelicans, and American robins were not statistically significant ($P > 0.05$). With landing lights on, there were associated increased risks of bird strikes involving doves, gulls, shorebirds, swallows and swifts, and owls. Conversely, there were associated decreased risks of bird strikes involving raptors and waders (Table 1.19). Further analyses on phase of flight were not performed because, as previously determined, the interaction between phase of flight and landing lights on, with respect to bird group, was not significant. The interaction between time of day and landing lights on was previously determined to be significant, however, there were insufficient data to perform these analyses.

Relative risks of damage also were calculated for the point of impact on an aircraft. Greatest risk of damage was associated with windscreen penetration (8.503). Strikes in which birds were ingested in engines (3.578) also had statistically significant high relative risk of damage, as did strikes to the outside of engines (1.807) and to weapons/missile pods (2.565). Bird strikes to the radome/nose and tail/rudder/stabilizer had increased risks, but were not statistically significant. Bird strikes to other parts of aircraft were statistically significant, however, the associated risks were all <1.0 (Table 1.20).

Of the 4 times of day analyzed, the relative risk of damage was greatest during the day (1.796). The relative risk of damage at night was <1.0 . Relative risks associated with dawn and dusk were not significant ($P > 0.05$; Table 1.21).

The calculation of relative risks demonstrated phases of flight when damage is more likely to result from a bird strike. The highest relative risks were for low-level (2.416) and range (3.252) operations. The relative risk of damage was significant ($P <$

0.05) and >1.0 for climb. Associated relative risks were significant ($P < 0.05$) and <1.0 for the following phases: final approach, landing, and traffic pattern. Cruise, descent, take-off, and touch and go/missed approach phases did not have significant ($P < 0.05$) associated risks (Table 1.22).

The calculation of relative risks for region (Table 1.23) revealed that in the conterminous United States, the relative risk of damage was greatest in the northwest region (1.431) followed by the southwest region (1.259), the southeast region (0.985), and the northeast region (0.714).

CHAPTER 1 TABLES AND FIGURES

Table 1.1 Interactions between independent variables contributing to USAF bird strikes with aircraft damage (DAMAGE) as the dependent variable.

Interactions	P	Interactions	P	Interactions	P
ACGRP * GROUP ^a	<0.001 ^b	IMPACTPT * TIMECAT	<0.001	ACGRP * PHASE	<0.001
ACGRP * IMPACTPT	<0.001	PHASE * GROUP	<0.001	ACGRP * SPEEDNO	<0.001
ACGRP * LANDLITE	<0.001	REGION * ALTCAT	<0.001	GROUP * MONTH	<0.001
TIMECAT * GROUP	<0.001	REGION * PHASE	<0.001	IMPACTPT * MONTH	<0.001
IMPACTPT * GROUP	<0.001	SPEEDNO * ALTCAT	<0.001	IMPACTPT * PHASE	<0.001
MONTH * ALTCAT	<0.001	SPEEDNO * IMPACTPT	<0.001	REGION * IMPACTPT	<0.001
PHASE * MONTH	<0.001	SPEEDNO * MONTH	<0.001	SPEEDNO * GROUP	<0.001
REGION * TIMECAT	<0.001	SPEEDNO * REGION	<0.001	SPEEDNO * GROUP	<0.001
REGION * MONTH	<0.001	ACGRP * MONTH	0.009	SPEEDNO * LANDLITE	<0.001
IMPACTPT * LANDLITE	0.008	IMPACTPT * ALTCAT	0.032	SPEEDNO * PHASE	<0.001
ACGRP * REGION	0.014	GROUP * ALTCAT	0.063	LANDLITE * GROUP	0.005
TIMECAT * PHASE	0.085	PHASE * ALTCAT	0.126	SPEEDNO * TIMECAT	0.035
LANDLITE * ALTCAT	0.159	REGION * LANDLITE	0.144	TIMECAT * LANDLITE	0.248
REGION * GROUP	0.390	TIMECAT * MONTH	0.209	TIMECAT * ALTCAT	0.299
LANDLITE * PHASE	0.552	LANDLITE * MONTH	0.641	ACGRP * TIMECAT	0.637
ACGRP * ALTCAT	0.872				

^a Variable descriptions in Appendix A.

^b P < 0.001

Table 1.2 Interactions between independent variables contributing to USAF bird strikes with bird group (GROUP) as the dependent variable.

Interactions	P	Interactions	P	Interactions	P
REGION * ACGRP ^a	<0.001 ^b	MONTH * ACGRP	0.013	REGION * PHASE	0.001
REGION * MONTH	<0.001	LANDLITE * ACGRP	0.014	REGION * SPEEDNO	0.021
LANDLITE * TIMECAT	0.005	REGION * TIMECAT	0.019	PHASE * TIMECAT	0.024
PHASE * MONTH	0.072	PHASE * SPEEDNO	0.076	TIMECAT * PATH	0.091
LANDLITE * REGION	0.085	LANDLITE * SPEEDNO	0.063	LANDLITE * PATH	0.107
MONTH * DAMAGE	0.171	PATH * TIMECAT	0.186	LANDLITE * ALTCAT	0.117
SPEEDNO * PATH	0.248	MONTH * ALTCAT	0.218	REGION * ALTCAT	0.133
REGION * PATH	0.249	PHASE * IMPACTPT	0.237	PHASE * PATH	0.262
ACGRP * IMPACTPT	0.291	ACGRP * PHASE	0.292	MONTH * TIMECAT	0.459
PATH * MONTH	0.300	LANDLITE * IMPACTPT	0.334	TIMECAT * ALTCAT	0.494
TIMECAT * IMPACTPT	0.366	SPEEDNO * ALTCAT	0.364	SPEEDNO * TIMECAT	0.498
MONTH * IMPACTPT	0.389	MONTH * LANDLITE	0.410	ACGRP * ALTCAT	0.517
LANDLITE * DAMAGE	0.401	ACGRP * SPEEDNO	0.534	REGION * IMPACTPT	0.520
ACGRP * PATH	0.456	ALTCAT * IMPACTPT	0.767	ACGRP * TIMECAT	0.789
MONTH * PATH	0.512	PHASE * DAMAGE	0.803	PHASE * ALTCAT	0.836
ALTCAT * PATH	0.582	DAMAGE * PATH	0.845	IMPACTPT * SPEEDNO	0.868
ACGRP * DAMAGE	0.899	TIMECAT * DAMAGE	0.908	DAMAGE * SPEEDNO	0.961
PHASE * LANDLITE	0.903	PATH * IMPACTPT	0.947	DAMAGE * REGION	0.973
DAMAGE * ALTCAT	0.961	REGION * DAMAGE	0.973	DAMAGE * IMPACTPT	0.992

^a Variable descriptions in Appendix A.

^b P < 0.001

Table 1.3 Damaging ($\geq \$10,000$) and non-damaging ($< \$10,000$) USAF bird strikes by year for FY 1988-1997.

Year	Totals^a	% Total^b	Damaging^c	Non-damaging^c
1988	2,658	10.0	3.9 (103)	96.1 (2,555)
1989	2,999	11.2	3.1 (94)	96.9 (2,905)
1990	3,059	11.5	3.9 (118)	96.1 (2,941)
1991	2,683	10.1	6.1 (165)	93.9 (2,518)
1992	2,401	9.0	4.8 (116)	95.2 (2,285)
1993	2,374	8.9	5.3 (126)	94.7 (2,248)
1994	2,230	8.4	4.1 (92)	95.9 (2,138)
1995	2,625	9.8	2.2 (59)	97.8 (2,566)
1996	2,918	10.9	2.7 (80)	97.3 (2,838)
1997	2,732	10.2	4.0 (109)	96.0 (2,623)

^a $n = 26,679$ total ($\bar{x} = 2,668$), $n = 1,062$ damaging ($\bar{x} = 106$), $n = 25,617$ non-damaging ($\bar{x} = 2,562$).

^b Percentage of total strikes ($n = 26,679$) for each year.

^c First number represents percentage of strikes within year, followed by number of strikes.

Table 1.4 Damaging (\geq \$10,000) and non-damaging ($<$ \$10,000) USAF bird strikes by month for FY 1988-1997.

Month	Total^a	% Total^b	% Damage^c	Damaging^d	Non-damaging^d
January	1,000	3.7	5.9	6.3 (63) ^e	93.7 (937)
February	939	3.5	6.1	6.9 (65) ^e	93.1 (874)
March	1,583	5.9	7.2	4.8 (76)	95.2 (1,507)
April	2,566	9.6	11.0	4.6 (117)	95.4 (2,449)
May	3,090	11.6	5.7	2.9 (90)	97.1 (3,000)
June	1,985	7.4	7.0	3.7 (74)	96.3 (1,911)
July	2,346	8.8	8.3	3.8 (88)	96.2 (2,258)
August	3,000	11.2	7.9	2.8 (84)	97.2 (2,916)
September	3,413	12.8	10.8	3.3 (114)	96.7 (3,299)
October	3,684	13.8	11.3	3.3 (120)	96.7 (3,564)
November	1,913	7.2	10.3	5.7 (109) ^e	94.3 (1,804)
December	1,037	3.9	5.7	5.8 (60) ^e	94.2 (977)

^a $n = 26,556$ ($\bar{x} = 2,213$), $n = 1,060$ damaging ($\bar{x} = 88$), $n = 25,496$ non-damaging ($\bar{x} = 2,125$).

^b Percentage of total strikes ($n = 26,556$) for each month (e.g., for January, $5.9 = 63/1060 \times 100$).

^c Percentage of total damaging strikes ($n = 1,060$) for each month.

^d First number represents percentage of strikes within month, followed by number of strikes.

^e Significantly ($P < 0.05$) greater than the mean percentage of damaging bird strikes across all months.

Table 1.5 Damaging ($\geq \$10,000$) and non-damaging ($< \$10,000$) USAF bird strikes by time of day (as reported by USAF personnel) for FY 1988-1997.

Time of Day	Total^a	% Total^b	Adj % Total^c	Damaging^d		Non-damaging^d	
Dawn	222	1.0	8.7	2.7	(6)	97.3	(216)
Day	14,866	65.5	38.8	4.7	(706)	95.3	(14,160)
Dusk	891	3.9	34.9	3.0	(27)	97.0	(864)
Night	6,712	29.6	17.5	2.8	(186)	97.2	(6,526)

^a $n = 22,691$ ($\bar{x} = 5,673$), $n = 925$ damaging ($\bar{x} = 231$), $n = 21,766$ non-damaging ($\bar{x} = 5,442$).

^b Percentage of total strikes ($n = 22,691$) for each time of day.

^c Percentage of bird strikes/hour by known time of day to USAF aircraft (Strikes/hour were calculated using an average day and night length of 11.25 hours and an average dawn and dusk length of 0.75 hours, each.).

^d First number represents percentage of strikes within time of day, followed by number of strikes.

Table 1.6 Damaging ($\geq \$10,000$) and non-damaging ($< \$10,000$) USAF bird strikes by aircraft phase of flight for FY 1988-1997.

Phase of Flight	Total^a	% Total^b	% Damage^c	Damaging^d		Non-damaging^d	
Climb	866	4.5	6.5	7.0	(61)	93.0	(805)
Cruise	891	4.6	5.5	5.8	(52)	94.2	(839)
Descent	253	1.3	1.3	4.7	(12)	95.3	(241)
Final approach	2,667	13.8	9.1	3.2	(86)	96.8	(2,581)
Landing	3,713	19.2	4.7	1.2	(44)	98.8	(3,669)
Low-level	4,340	22.4	41.1	8.9	(387) ^e	91.1	(3,953)
Touch & go/missed approach	1,394	7.2	6.5	4.4	(61)	95.6	(1,333)
Range	194	1.0	3.2	15.5	(30) ^e	84.5	(164)
Take-off	2,988	15.4	15.5	4.9	(146)	95.1	(2,842)
Traffic pattern	2,046	10.6	6.6	3.0	(62)	97.0	(2,046)

^a $n = 19,352$ ($\bar{x} = 1,935$), $n = 941$ damaging ($\bar{x} = 94$), $n = 18,411$ non-damaging ($\bar{x} = 1,841$).

^b Percentage of total strikes ($n = 19,352$) for each phase of flight.

^c Percentage of total damaging strikes ($n = 941$) for each phase of flight.

^d First number represents percentage of strikes within phase of flight, followed by number of strikes.

^e Significantly ($P < 0.05$) greater than the mean percentage of damaging bird strikes across all phases of flight.

Table 1.7 Damaging (\geq \$10,000) and non-damaging ($<$ \$10,000) USAF bird strikes by aircraft group for FY 1988-1997.

Aircraft Group	Total^a	% Total^b	% Damage^c	Damaging^d	Non-damaging^d
Fighter/attack	6,581	25.1	34.1	5.4 (357)	94.6 (6,224)
Cargo/airlift/transport	11,565	44.2	26.9	2.4 (282)	97.6 (11,283)
Trainer	4,279	16.4	18.8	4.6 (197)	95.4 (4,082)
Bomber	2,172	8.3	15.7	7.6 (165) ^e	92.4 (2,007)
Reconnaissance	1,315	5.0	3.8	3.0 (40)	97.0 (1,275)
Other	256	1.0	0.6	2.7 (7)	97.3 (249)

^a Excluding “others”: $n = 25,912$ ($\bar{x} = 5,182$), $n = 1,041$ damaging ($\bar{x} = 208$), $n = 24, 871$ non-damaging ($\bar{x} = 4,974$).

^b Percentage of total strikes ($n = 26, 168$) for each aircraft group.

^c Percentage of total damaging strikes ($n = 1,048$) for each aircraft group.

^d First number represents percentage of strikes within aircraft group, followed by number of strikes.

^e Significantly ($P < 0.05$) greater than the mean percentage of damaging bird strikes across all aircraft groups.

Table 1.8 USAF bird strikes during airfield and low level/range operations by aircraft group for FY 1988-1997.

Aircraft Group	Total^a	Airfield^b		Low-level/Range^b	
Fighter/attack	3,374	20.4	36.9 (1,620)	39.3	39.9 (1,754)
Cargo/airlift/transport	1,998	47.2	42.8 (3,751)	36.5	18.6 (1,627)
Trainer	1,961	22.0	54.6 (1,754)	4.6	6.4 (207)
Bomber	928	3.7	22.0 (297)	14.2	46.7 (631)
Reconnaissance	680	6.4	48.3 (511)	3.8	16.0 (169)

^a n = 18,994 (\bar{x} = 3,799), n = 7,933 airfield operations (\bar{x} = 1,587), n = 11,061 low-level/range operations (\bar{x} = 2,212). Strikes during other phases of flight not shown.

^b First number represents percentage of strikes within phase of flight, second number represents percentage of strikes within aircraft group, followed by number of strikes.

Table 1.9 Damaging ($\geq \$10,000$) and non-damaging ($< \$10,000$) USAF bird strikes by aircraft impact point for FY 1988-1997.

Impact Point	Total^a	% Total^b	% Damage^c	Damaging^d		Non-damaging^d	
Engine ingestion	4,530	17.7	37.3	10.0	(453)	90.0	(4,077)
Outside engine	1,570	6.1	9.1	7.0	(110)	93.0	(1,460)
Fuselage/antenna/skin	3,147	12.3	5.6	2.2	(68)	97.8	(3,079)
Radome/nose	5,127	20.0	15.2	3.6	(185)	96.4	(4,942)
Windshield/canopy	4,738	18.5	7.9	2.0	(96)	98.0	(4,642)
Tail/stabilizer/rudder	387	1.5	1.3	4.1	(16)	95.9	(371)
Weapons/missile pod	145	0.6	1.2	10.3	(15)	89.7	(130)
Landing gear	1,670	6.5	2.0	1.4	(24)	98.6	(1,646)
Lights	125	0.5	0.3	3.2	(4)	96.8	(121)
Wings	5,625	21.9	14.9	3.2	(181)	96.8	(5,444)
Fuel tanks	296	1.2	0.9	3.7	(11)	96.3	(285)
Propellers	195	0.8	0.6	3.6	(7)	96.4	(188)
ECM pod/pylons	381	1.5	2.4	7.6	(29)	92.4	(352)
Rotor	45	0.2	0.2	6.7	(3)	93.3	(42)
Windshield penetration	38	0.1	1.1	34.2	(13) ^e	65.8	(25)

^a $n = 28,019$ ($\bar{x} = 1,868$). Note: $n > 26,679$ (total number of strikes) because multiple points are struck on aircraft. Impact points were not reported for 1,040 strikes. Impact points were designated simply as “multiple points” for 104 strikes, and are not included in totals. $n = 1,215$ damaging ($\bar{x} = 81$), $n = 26,804$ non-damaging ($\bar{x} = 1,787$).

^b Percentages calculated using $n = 25,535$ (number of strikes with specific impact points recorded). Total of percentages is >100 because multiple points are struck on aircraft.

^c Percentage of total damaging strikes ($n = 1,215$) for each impact point.

^d First number represents percentage of strikes within point of impact, followed by number of strikes.

^e Significantly ($P < 0.05$) greater than the mean percentage of damaging bird strikes across all impact points on aircraft.

Table 1.10 Damaging (\geq \$10,000) and non-damaging ($<$ \$10,000) USAF bird strikes by aircraft speed (KIAS) for FY 1988-1997.

Aircraft Speed	Total^a	% Total^b	% Damage^c	Damaging^d	Non-damaging^d
0-50 KIAS	4,020	18.1	16.5	3.7 (149)	96.3 (3,871)
51-100 KIAS	1,194	5.4	2.1	1.6 (19)	98.4 (1,175)
101-150 KIAS	6,521	29.4	14.7	2.0 (133)	98.0 (6,388)
151-200 KIAS	4,711	21.3	15.5	3.0 (140)	97.0 (4,571)
201-250 KIAS	2,479	11.2	12.4	4.5 (112)	95.5 (2,367)
251-300 KIAS	842	3.8	7.4	8.0 (67)	92.0 (775)
>300 KIAS	2,396	10.8	31.3	11.8 (283) ^e	88.2 (2,113)

^a $n = 22,163$ ($\bar{x} = 3,166$), $n = 903$ damaging ($\bar{x} = 129$), $n = 21,260$ non-damaging ($\bar{x} = 3,037$).

^b Percentage of total strikes ($n = 22,163$) for each speed category.

^c Percentage of total damaging strikes ($n = 903$) for each speed category.

^d First number represents percentage of strikes within speed category, followed by number of strikes.

^e Significantly ($P < 0.05$) greater than the mean percentage of damaging bird strikes across all speed categories.

Table 1.11 USAF bird strikes during airfield and low level/range operations by aircraft speed (KIAS) for FY 1988-1997.

Aircraft Speed	Total^a	% Total^b	Airfield^c	Low-level/range^c
0-50 KIAS	4,020	18.1	45.9 (365)	22.0 (175)
51-100 KIAS	1,194	5.4	84.7 (1,003)	2.6 (31)
101-150 KIAS	6,521	29.4	64.4 (4,119)	2.8 (177)
151-200 KIAS	4,711	21.3	39.2 (1,772)	6.2 (281)
201-250 KIAS	2,479	11.2	10.8 (252)	60.6 (1,420)
251-300 KIAS	842	3.8	16.3 (129)	39.9 (316)
>300 KIAS	2,396	10.8	2.9 (66)	84.7 (1,907)

^a n = 22,163 (\bar{x} = 3,166), n = 7,706 airfield (\bar{x} = 1,101), n = 4,307 low level/range (\bar{x} = 615).

^b Percentage of total strikes (n = 22,163) for each speed category.

^c First number represents percentage of strikes within speed category, followed by number of strikes.

Table 1.12 Damaging (\geq \$10,000) and non-damaging ($<$ \$10,000) USAF bird strikes by aircraft altitude (ft AGL) for FY 1988-1997.

Aircraft Altitude	Total^a	% Total^b	% Damage^c	Damaging^d	Non-damaging^d
0-500 ft. AGL	14,683	66.9	60.2	3.8 (562)	96.2 (14,121)
501-1,000 ft. AGL	3,187	14.5	19.5	5.7 (182)	94.3 (3,005)
1,001-1,500 ft. AGL	1,390	6.3	8.1	5.5 (76)	94.5 (1,314)
1,501-2,000 ft. AGL	1,243	5.7	4.7	3.5 (44)	96.5 (1,199)
2,001-2,500 ft. AGL	354	1.6	1.9	5.1 (18)	94.9 (336)
2,501-3,000 ft. AGL	495	2.3	2.5	4.6 (23)	95.4 (472)
3,001-3,500 ft. AGL	96	0.4	0.9	9.4 (9) ^e	90.6 (87)
3,501-4,000 ft. AGL	142	0.6	0.7	4.9 (7)	95.1 (135)
4,001-6,000 ft. AGL	233	1.1	0.9	3.9 (9)	96.1 (224)
>6,000 ft. AGL	134	0.6	0.4	3.0 (4)	97.0 (130)

^a $n = 21,957$ ($\bar{x} = 2,196$), $n = 934$ damaging ($\bar{x} = 93$), $n = 21,023$ non-damaging ($\bar{x} = 2,102$).

^b Percentage of total strikes ($n = 21,957$) for each altitude category.

^c Percentage of total damaging strikes ($n = 934$) for each altitude category.

^d First number represents percentage of strikes within altitude category, followed by number of strikes.

^e Significantly ($P < 0.05$) greater than the mean percentage of damaging bird strikes across all altitude categories.

Table 1.13 Damaging (\geq \$10,000) and non-damaging ($<$ \$10,000) USAF bird strikes by bird group for FY 1988-1997.

Bird Group	Total^a	% Total^b	% Damage^c	Damaging^d	Non-damaging^d
Crows and ravens	72	0.9	0.8	5.6 (4)	94.4 (68)
Ducks	278	3.6	8.0	14.4 (40)	85.6 (238)
Geese and swans	91	1.2	7.6	41.8 (38) ^e	58.2 (53)
Pelicans	22	0.3	1.4	31.8 (7) ^e	68.2 (15)
Gulls	770	10.1	14.3	9.4 (72)	90.6 (698)
Raptors and owls	1,374	18.0	44.3	16.2 (223)	83.8 (1,151)
Blackbirds and starlings	799	10.5	3.2	2.0 (16)	98.0 (783)
Shorebirds	372	4.9	1.6	2.2 (8)	97.8 (364)
Waders	162	2.1	3.8	11.7 (19)	88.3 (143)
American robins	162	2.1	0.2	0.6 (1)	99.4 (161)
Horned larks	645	8.4	2.2	1.7 (11)	98.3 (634)
Doves	662	8.7	4.4	3.3 (22)	96.7 (640)
Swallows and swifts	667	8.7	2.2	1.6 (11)	98.4 (656)
Others	1,565	20.5	6.2	2.0 (31)	98.0 (1,534)

^a Excluding “others”: n = 6,076 (\bar{x} = 467), n = 472 damaging (\bar{x} = 36), n = 5,604 non-damaging (\bar{x} = 431).

^b Percentage of total strikes (n = 7,641) for each bird group.

^c Percentage of total damaging strikes (n = 503) for each bird group.

^d First number represents percentage of strikes within bird group, followed by number of strikes.

^e Significantly ($P < 0.05$) greater than the mean percentage of damaging bird strikes across all bird groups.

Table 1.14 USAF bird strikes during airfield and low level/range operations by bird group for FY 1988-1997.

Bird Group	Total^a	Airfield^b		Low-level/Range^b		
Crows and ravens	40	0.8	36.4 (24)	1.5	24.2	(16)
Ducks	119	1.5	20.6 (46)	6.7	32.7	(73)
Geese and swans	46	0.7	27.7 (23)	2.1	27.7	(23)
Pelicans	8	0.1	21.1 (4)	0.4	21.1	(4)
Gulls	518	12.6	56.2 (392)	11.5	18.1	(126)
Raptors and owls	814	11.7	32.0 (366)	40.9	39.2	(448)
Blackbirds and starlings	484	13.4	65.0 (419)	5.9	10.1	(65)
Shorebirds	220	6.5	74.3 (202)	1.6	6.6	(18)
Waders	112	2.8	58.5 (86)	2.4	17.7	(26)
American robins	63	1.3	44.2 (42)	1.9	22.1	(21)
Horned larks	262	6.8	60.6 (211)	4.7	14.7	(51)
Doves	421	12.3	73.8 (383)	3.5	7.3	(38)
Swallows and swifts	314	8.6	59.6 (269)	4.1	10.0	(45)
Others	796	21.0	59.4 (655)	12.9	12.8	(141)

^a Excluding “others”: n = 5,015 (\bar{x} = 467), n = 2,467 airfield (\bar{x} = 190), n = 2,548 low level/range (\bar{x} = 196).

Strikes during other phases of flight not shown.

^b First number represents percentage of strikes within phase of flight, second number represents percentage of strikes within bird group, followed by number of strikes.

Table 1.15 Damaging (\geq \$10,000) and non-damaging ($<$ \$10,000) USAF bird strikes by bird size for FY 1988-1997.

Bird Size^a	Total^b	% Total^c	% Damage^d	Damaging^e	Non-damaging^e
Small	3,387	56.1	14.9	2.1 (70)	97.9 (3,317)
Small-medium	1,126	18.6	16.8	7.0 (79)	93.0 (1,047)
Medium	680	11.3	16.0	11.0 (75)	89.0 (605)
Large	846	14.0	52.3	29.1 (246)	70.9 (600)

^a Small = 0-<10 oz, Small-medium = 10-<20 oz, Medium = 20-<40 oz, Large = \geq 40 oz.

^b n = 6,039 (\bar{x} = 1,510), n = 470 damaging (\bar{x} = 118), n = 1,040 non-damaging (\bar{x} = 260).

^c Percentage of total strikes (n = 6,039) for each bird size category.

^d Percentage of total damaging strikes (n = 470) for each bird size category.

^e First number represents percentage of strikes within bird size category, followed by number of strikes.

Table 1.16 Damaging (\geq \$10,000) and non-damaging ($<$ \$10,000) USAF bird strikes by region for FY 1988-1997.

Region	Total^a	% Total^b	Damaging^c	Non-damaging^c
USNE	1,775	10.5	3.5 (62)	96.5 (1,713)
USSE	8,477	50.2	4.7 (399)	95.3 (8,078)
USNW	951	5.6	6.6 (63)	93.4 (888)
USSW	3,087	18.3	5.7 (176)	94.3 (2,911)
Pacific	204	1.2	4.4 (9)	95.6 (195)
Canada	13	0.1	23.1 (3) ^e	76.9 (10)
East	745	4.4	3.1 (23)	96.9 (722)
Middle East	319	1.9	2.8 (9)	97.2 (310)
Europe	1,215	7.2	4.1 (50)	95.9 (1,165)
Atlantic	66	0.4	4.5 (3)	95.5 (63)
South of NA	33	0.2	9.1 (3)	90.9 (30)
Africa	6	0.0 ^d	16.7 (1) ^e	83.3 (5)

^a $n = 16,891$ ($\bar{x} = 1,408$), $n = 800$ damaging ($\bar{x} = 67$), $n = 608$ non-damaging ($\bar{x} = 51$).

^b Percentage of total strikes ($n = 16,891$) for each region.

^c First number represents percentage of strikes within region, followed by number of strikes.

^d $<0.01\%$.

^e Significantly ($P < 0.05$) greater than the mean percentage of damaging bird strikes across all regions.

Table 1.17 Relative risks, based on FY 1988-1997 USAF bird strike data, of damaging bird strikes for bird groups.

Bird Group	Relative Risk	P
Geese and swans	10.924	<0.001
Pelicans	4.888	<0.001
Raptors	2.759	<0.001
Ducks	2.288	<0.001
Waders	1.812	0.015
Gulls	1.491	0.001
Crows and ravens	0.843	0.724 ^e
Doves	0.482	<0.001
Shorebirds	0.316	<0.001
Owls	0.294	0.063
Blackbirds	0.281	<0.001
Horned larks	0.243	<0.001
Swallows and swifts	0.234	<0.001
American robins	0.092	0.002

^e Not significant by Fisher's two-tailed exact test or the 95 % confidence interval.

Table 1.18 Relative risks, based on FY 1988-1997 USAF bird strike data, of damaging bird strikes for bird sizes.

Bird Size	Relative Risk	P
Small	0.119	<0.001
Small-Medium	0.879	0.324 ^e
Medium	1.558	0.001
Large	9.095	<0.001

^e Not significant by Fisher's two-tailed exact test or the 95 % confidence interval.

Table 1.19 Relative risks, based on FY 1988-1997 USAF bird strike data, of striking bird groups with landing lights on.

Bird Group	Relative Risk	P
Owls	1.341	0.001
Shorebirds	1.231	<0.001
Doves	1.192	<0.001
Gulls	1.122	<0.001
Swallows and swifts	1.101	0.004
Blackbirds	1.047	0.121
Horned larks	1.020	0.545
Ducks	0.930	0.174
American robins	0.929	0.314
Geese	0.886	0.211
Crows and ravens	0.803	0.029 ^e
Waders	0.761	<0.001
Pelicans	0.729	0.109
Raptors	0.635	<0.001

^e Not significant by the 95 % confidence interval. Significant by Fisher's two-tailed exact test.

Table 1.20 Relative risks, based on FY 1988-1997 USAF bird strike data, of damaging bird strikes for impact points.

Impact Point	Relative Risk	P
Windscreen penetration	8.503	<0.001
Engine Ingestion	3.578	<0.001
Weapons/missile pod	2.565	0.001
Pylons/pods	1.896	0.001
Outside engine	1.807	<0.001
Tail/rudder/stabilizer	1.017	0.897 ^e
Radome/nose	0.863	0.063
Wings	0.747	<0.001
Fuselage/antenna/skin	0.498	<0.001
Windshield/canopy	0.447	<0.001
Landing gear	0.338	<0.001

^e Not significant by Fisher's two-tailed exact test or the 95 % confidence interval.

Table 1.21 Relative risks, based on FY 1988-1997 USAF bird strike data, of damaging bird strikes for times of day.

Time of Day	Relative Risk	P
Dawn	0.769	0.186 ^e
Day	1.796	<0.001
Dusk	0.690	0.484 ^e
Night	0.640	<0.001

^e Not significant by Fisher's two-tailed exact test or the 95 % confidence interval.

Table 1.22 Relative risks, based on FY 1988-1997 USAF bird strike data, of damaging bird strikes for phases of flight.

Phase of Flight	Relative Risk	P
Range	3.252	<0.001
Low-level	2.416	<0.001
Climb	1.480	0.004
Cruise	1.212	0.175 ^e
Take-off	1.006	0.926 ^e
Descent	0.975	1.000 ^e
Touch & go/missed approach	0.893	0.438 ^e
Final approach	0.629	<0.001
Traffic pattern	0.597	<0.001
Landing	0.207	<0.001

^e Not significant by Fisher's two-tailed exact test or the 95 % confidence interval.

Table 1.23 Relative risks, based on FY 1988-1997 USAF bird strike data, of damaging bird strikes for regions of the world.

Region	Relative Risk	P
Canada	4.881	0.021
USNW	1.431	0.007
USSW	1.259	0.007
USNE	0.714	0.008
USSE	0.985	0.856 ^e
East	0.641	0.030
Middle East	0.590	0.111 ^e
Africa	3.518	0.253 ^e
South of NA	1.920	0.205 ^e
Europe	0.859	0.326 ^e
Pacific	0.930	1.000 ^e
Atlantic	0.958	1.000 ^e

^e Not significant by Fisher's two-tailed exact test or the 95 % confidence interval.

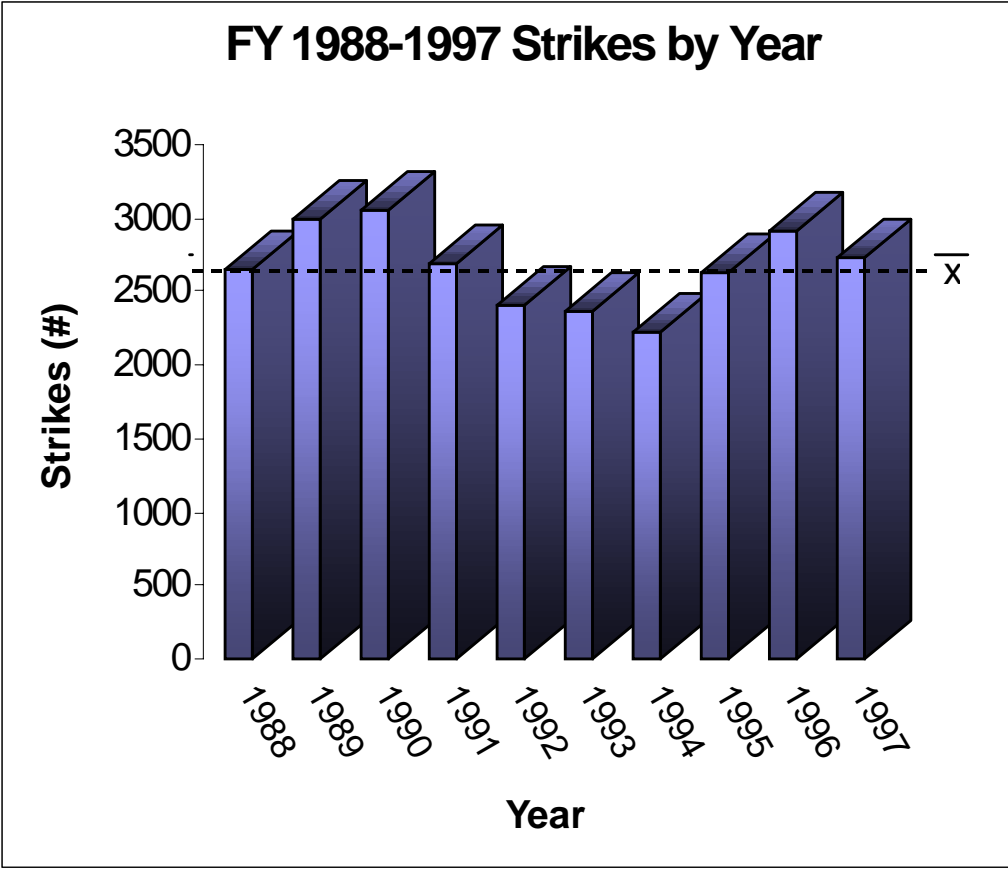

Figure 1.1 USAF bird strikes by year for FY 1988-1997 ($\bar{x} = 2,668$).

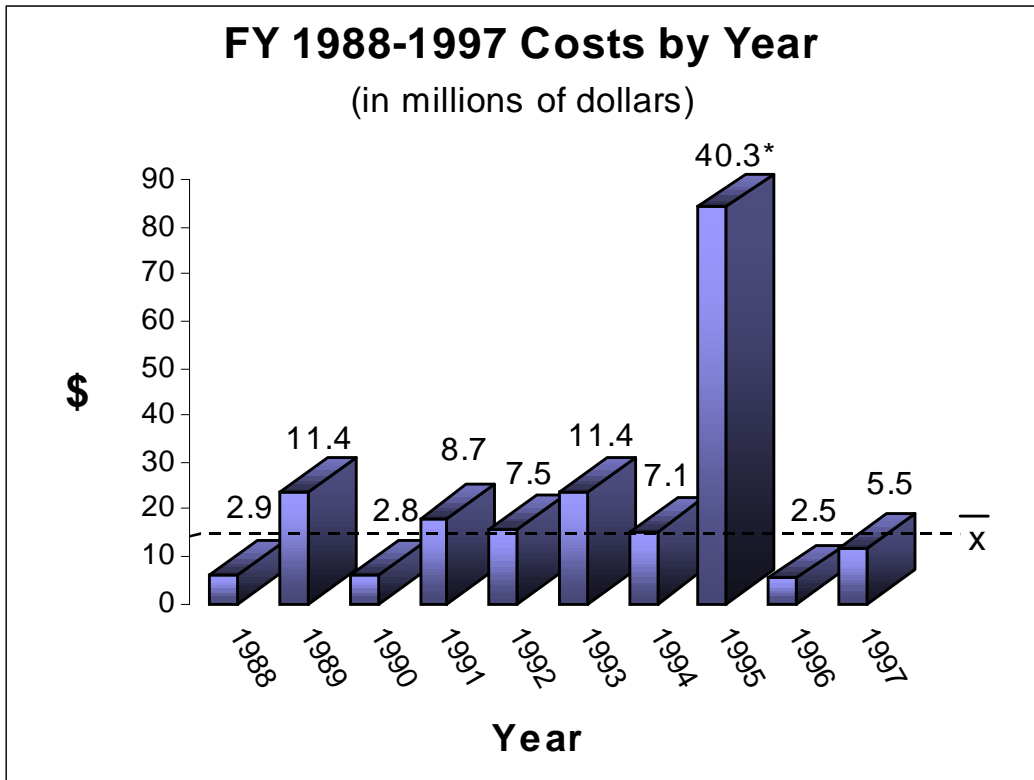

Figure 1.2 USAF bird strike costs by year for FY 1988-1997 ($\bar{x} = \$14.5$ million).

* Numbers above columns represent percent of total bird strikes.

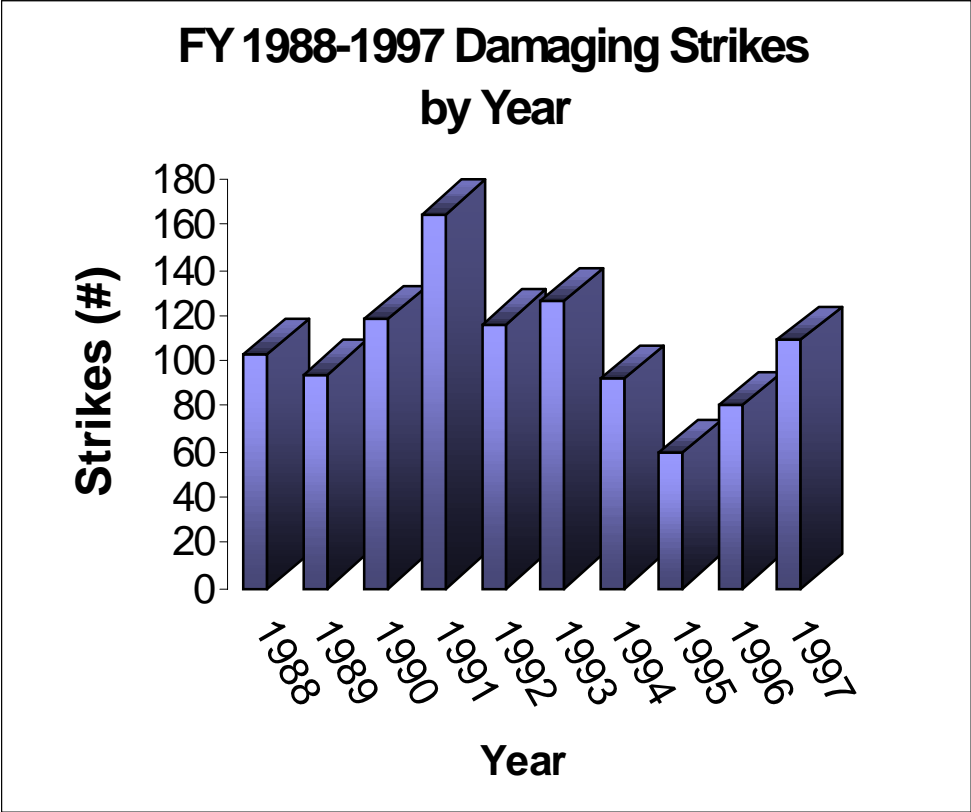

Figure 1.3 USAF damaging bird strikes by year for FY 1988-1997.

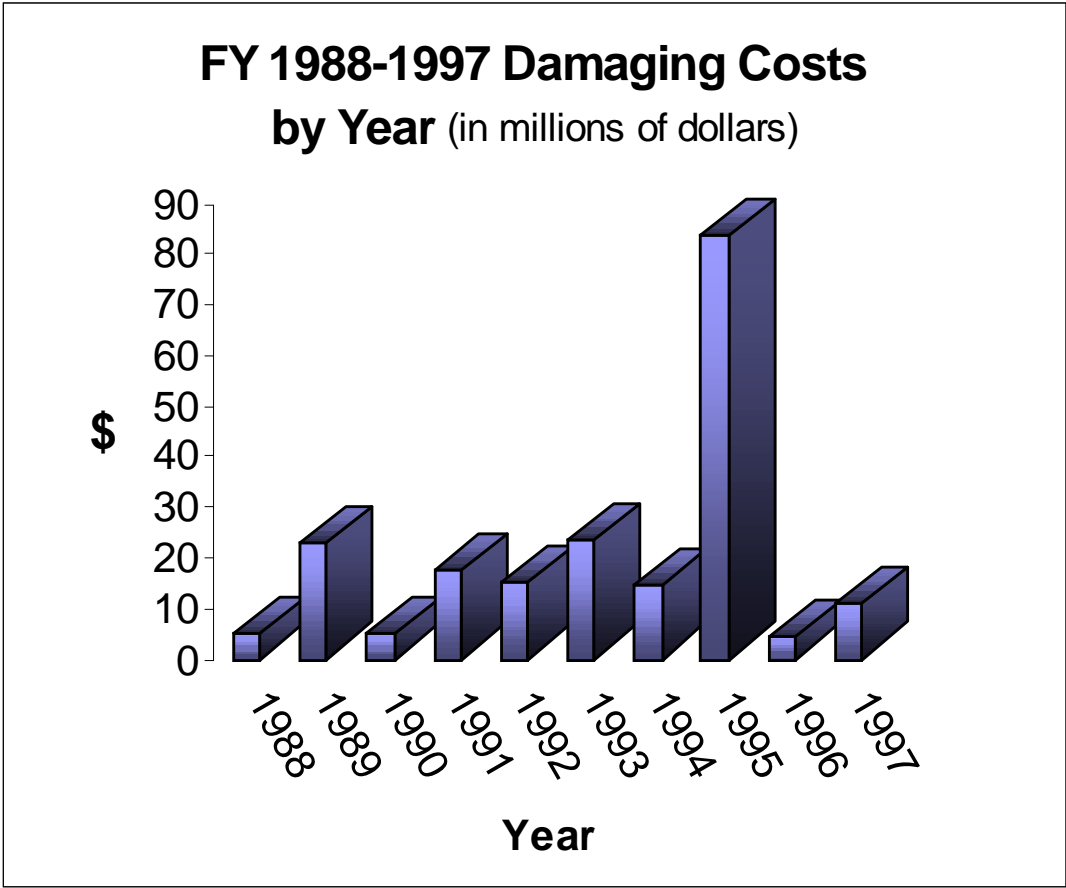

Figure 1.4 USAF damaging bird strike costs by year for FY 1988-1997.

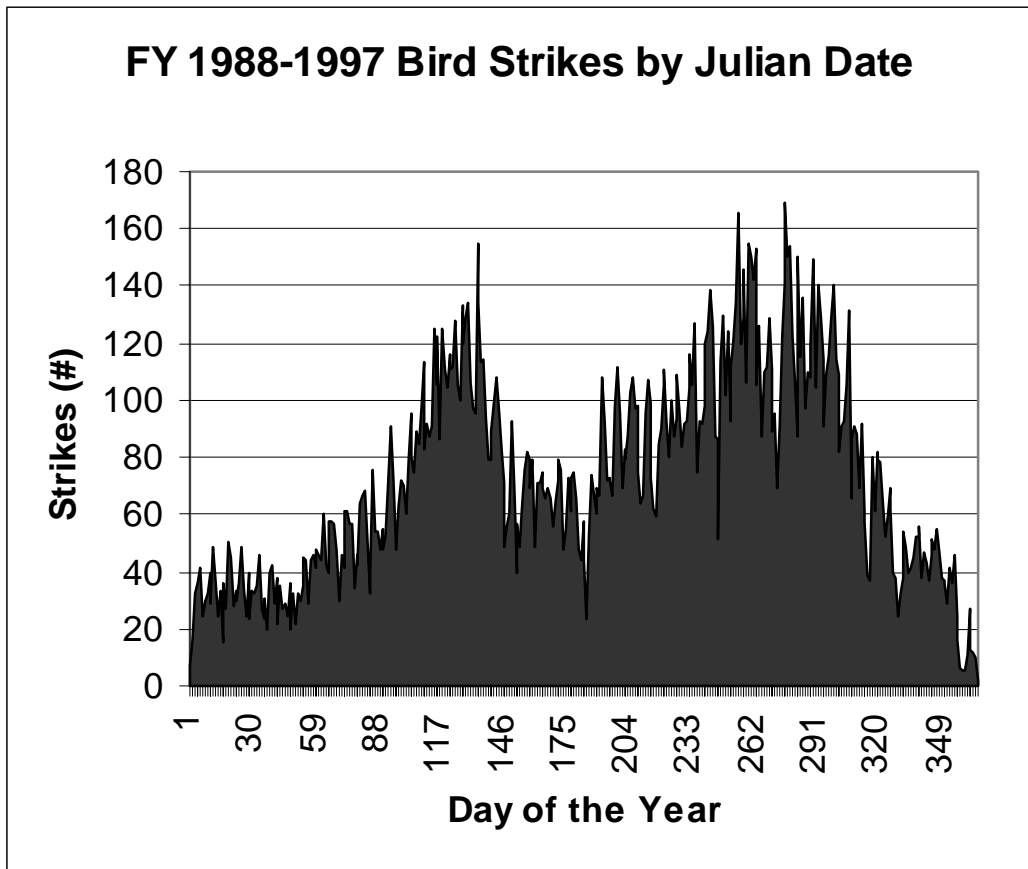

Figure 1.5 USAF mean bird strikes by Julian date for FY 1988-1997.

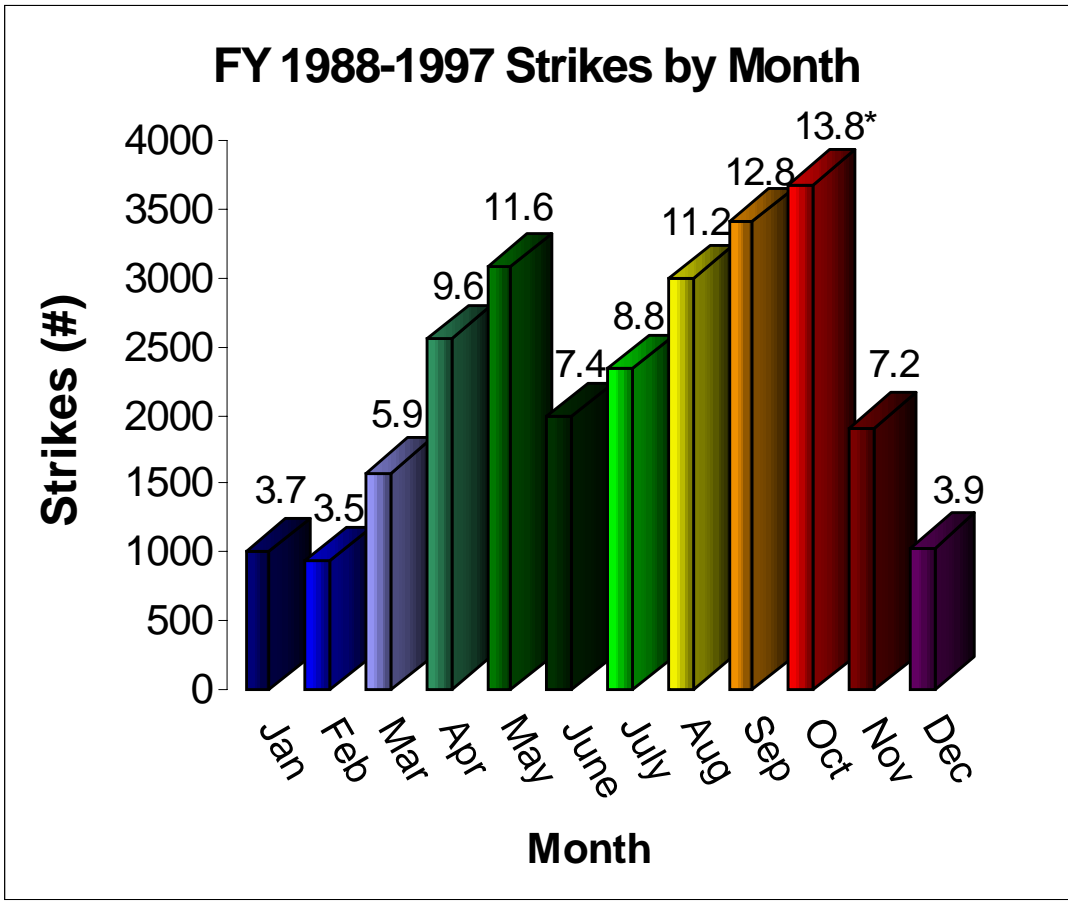

Figure 1.6 USAF bird strikes by month for FY 1988-1997.

Colors depict the change in season (winter = purple – blue, spring – summer = green – yellow, and fall = orange – red).

* Numbers above columns represent percent of total bird strikes.

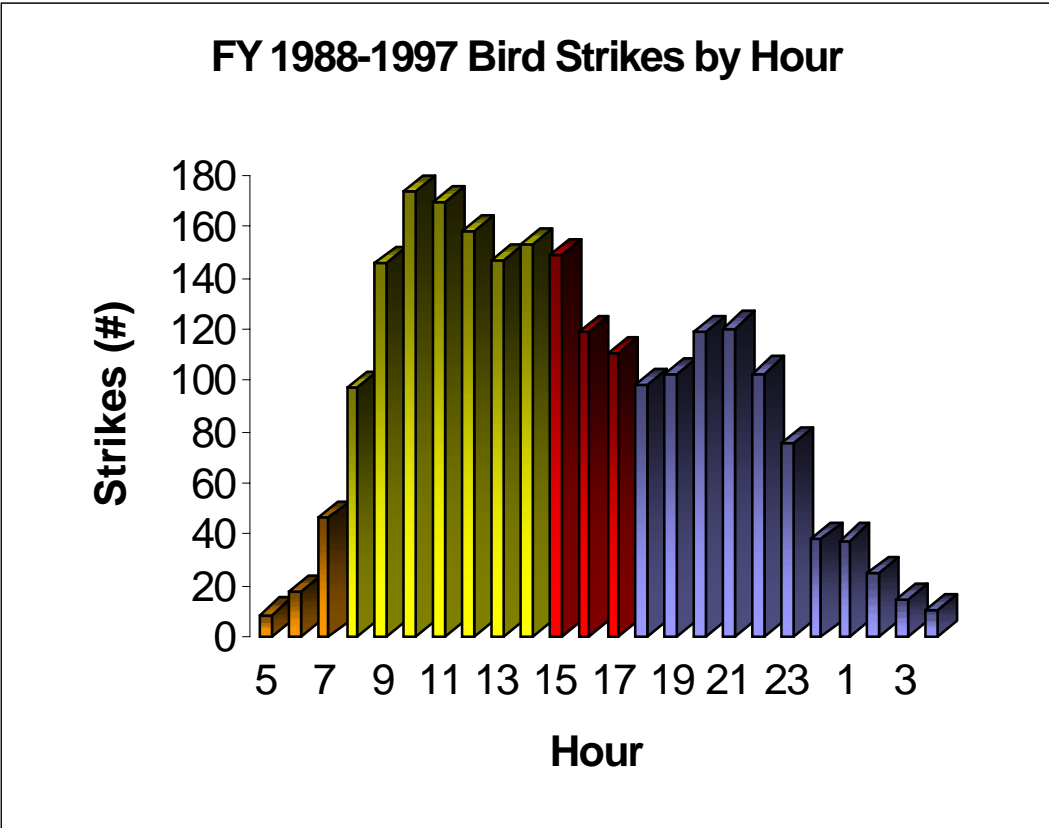

Figure 1.7 USAF mean bird strikes by hour for FY 1988-1997.
 Colors depict the change in period of day
 (dawn = orange, yellow = day, dusk = red, and night = blue).

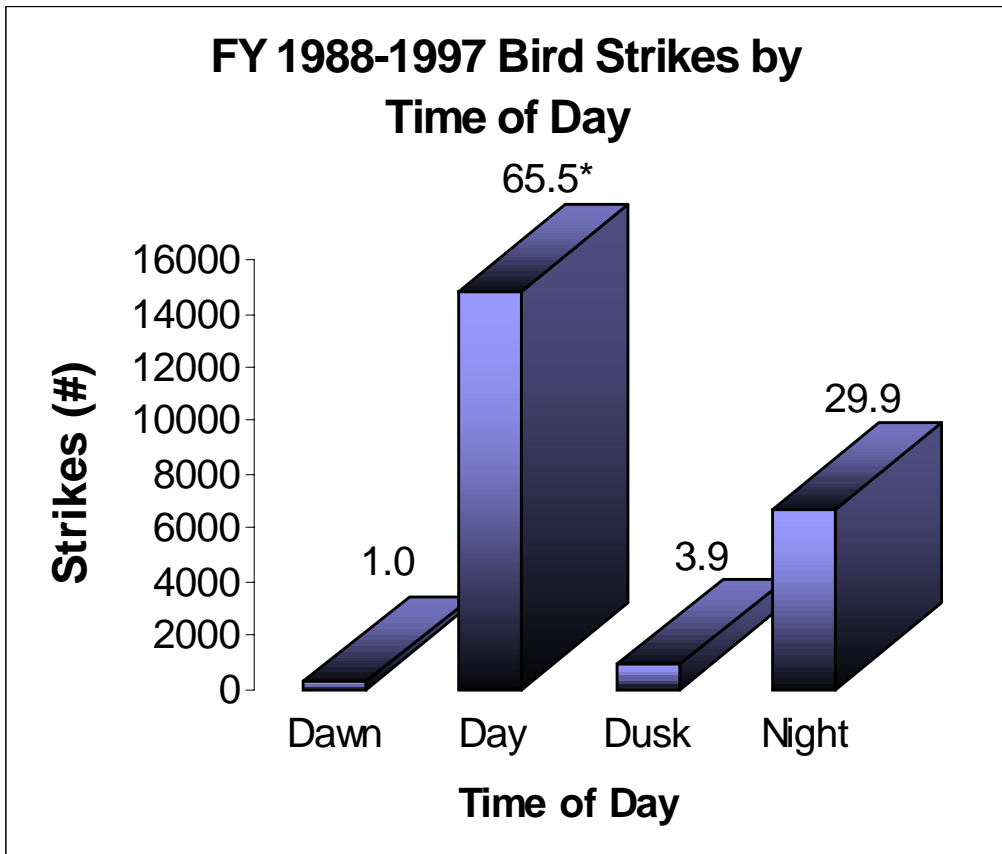

Figure 1.8 USAF bird strikes by time of day for FY 1988-1997.

* Numbers above columns represent percent of total bird strikes.

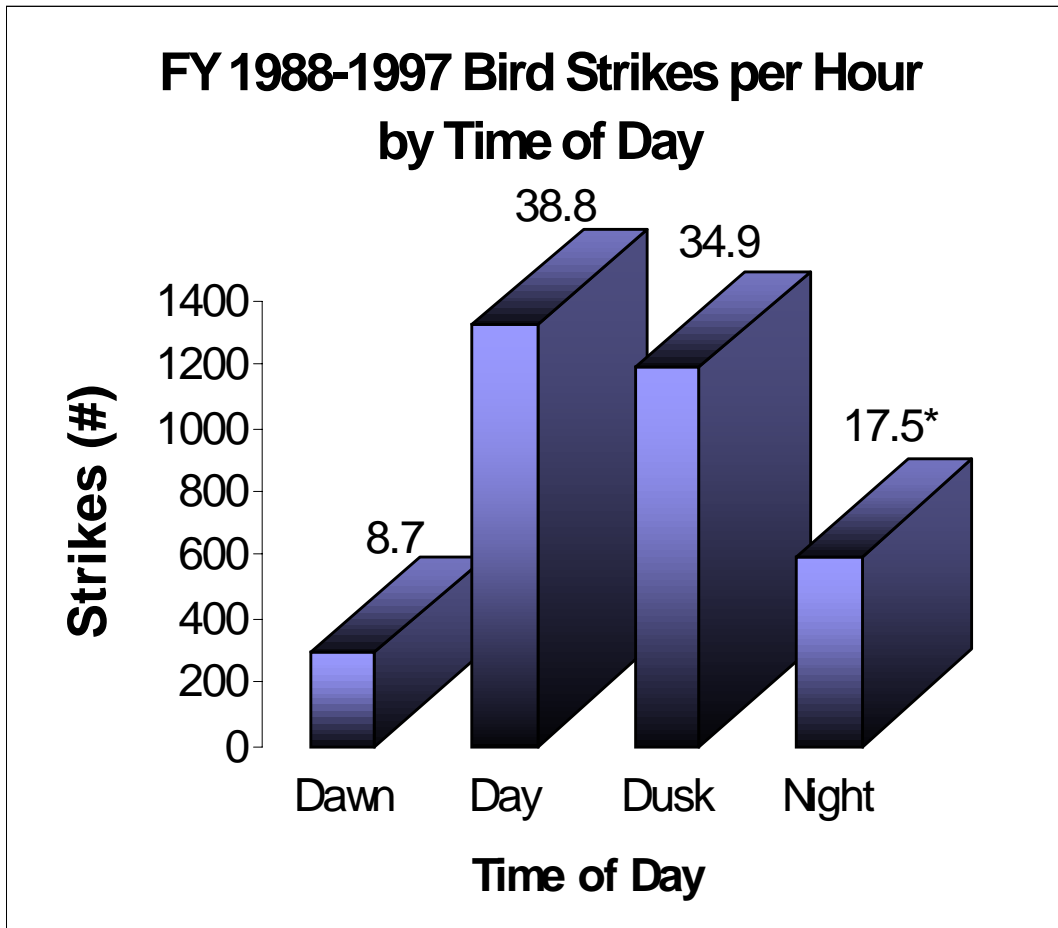

Figure 1.9 USAF bird strikes per hour by time of day for FY 1988-1997.

* Numbers above columns represent percent of total bird strikes.

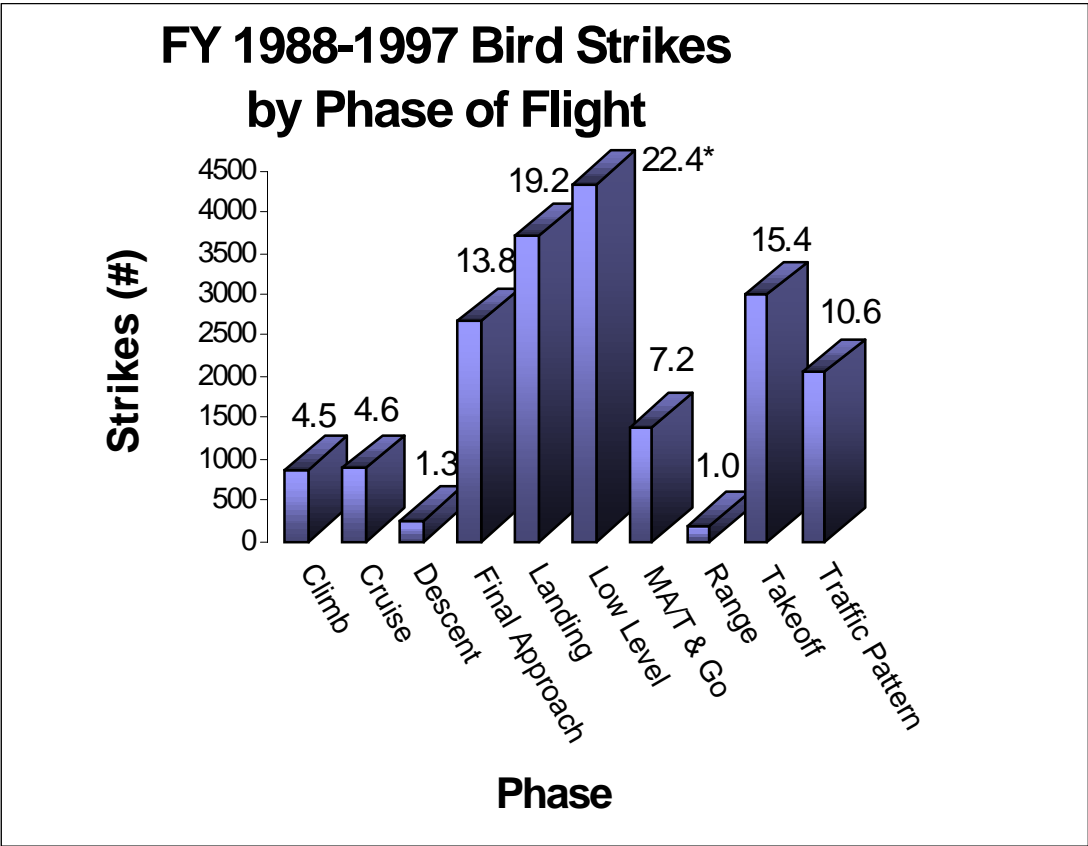

Figure 1.10 USAF bird strikes by phase of flight for FY 1988-1997.

*Numbers above columns represent percent of total bird strikes.

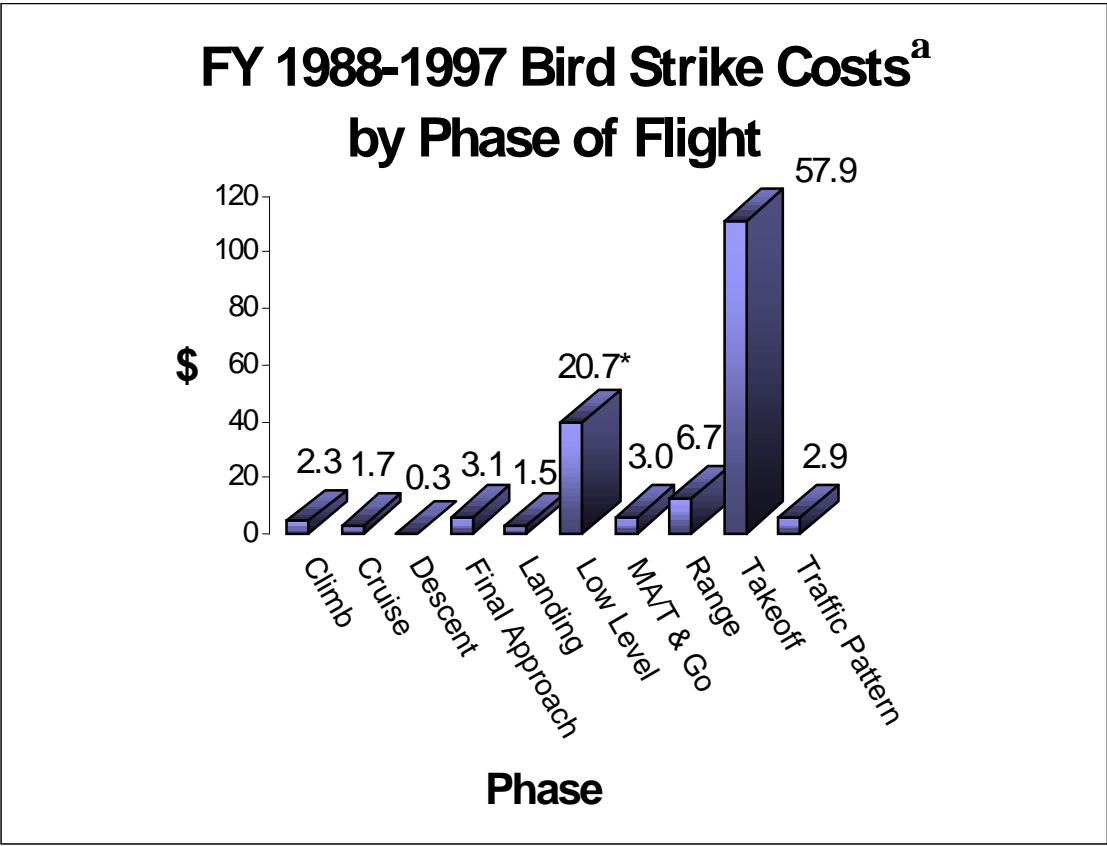

Figure 1.11 USAF bird strike costs by phase for FY 1988-1997.

^a Costs in millions of dollars.

* Numbers above columns represent percent of total bird strikes.

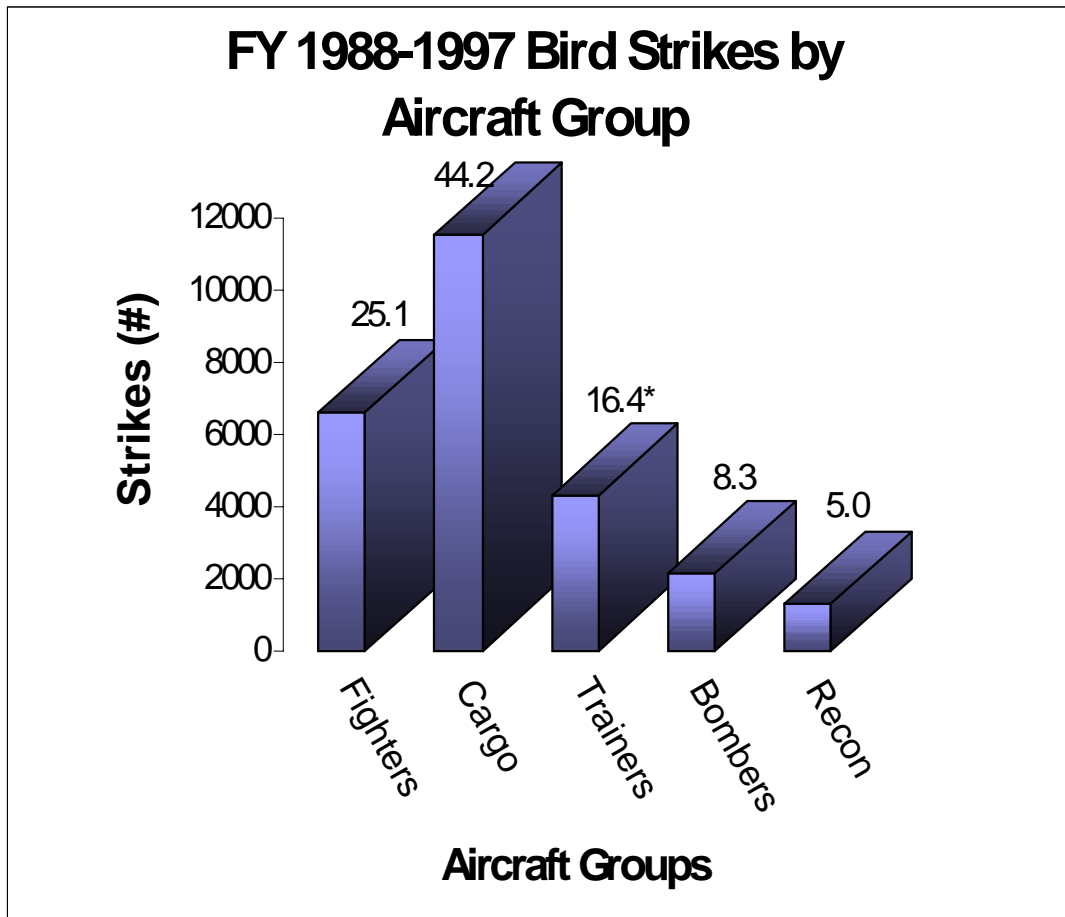

Figure 1.12 USAF bird strikes by aircraft group for FY 1988-1997.
 * Numbers above columns represent percent of total bird strikes.

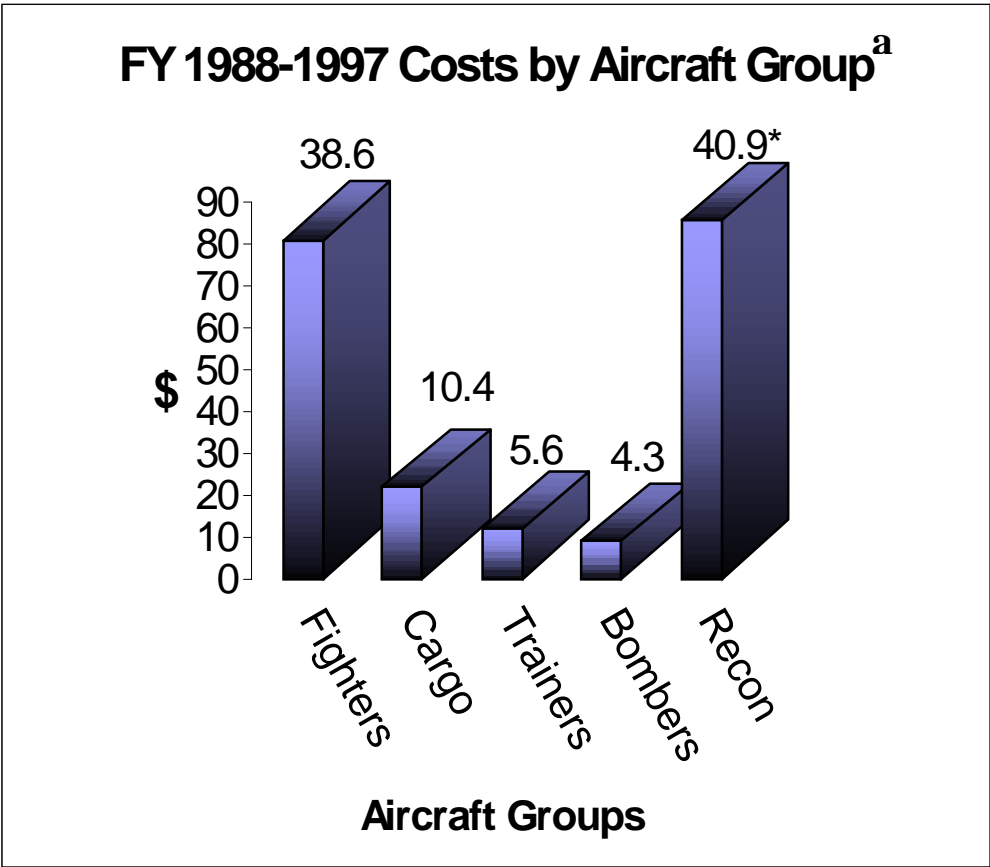

Figure 1.13 USAF bird strike costs by aircraft group for FY 1988-1997.

^a Costs in millions of dollars.

* Numbers above columns represent percent of total bird strikes.

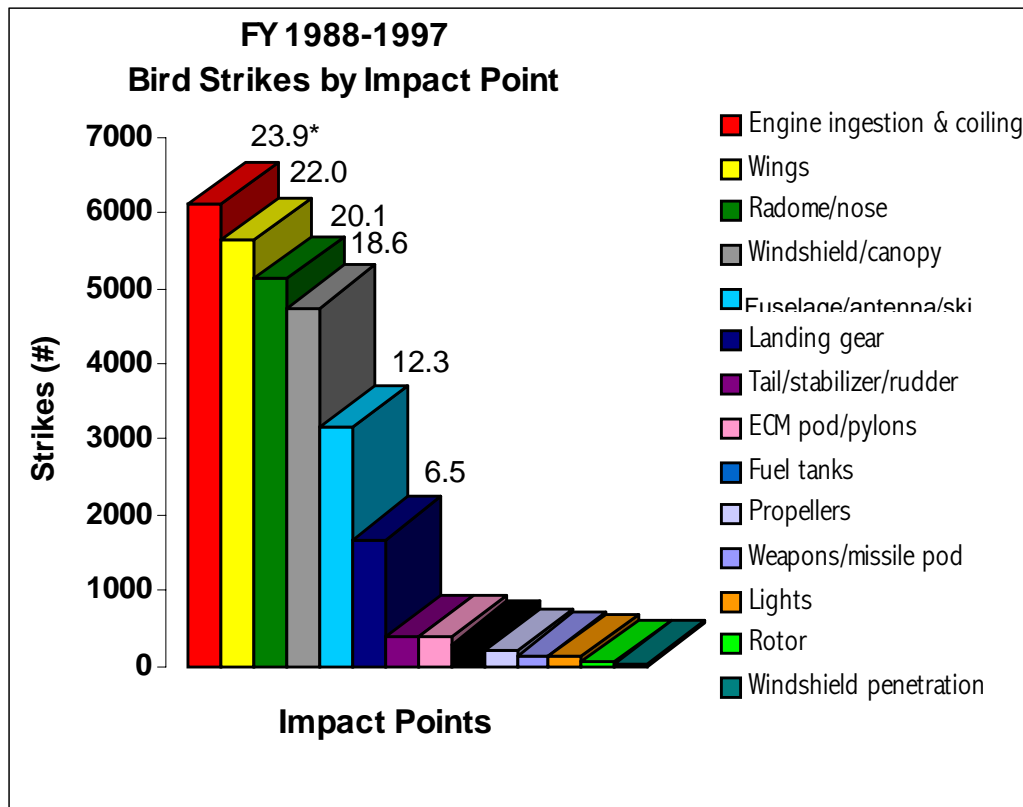

Figure 1.14 USAF bird strikes by point of impact on aircraft for FY 1988-1997.

* Numbers above columns represent percent of total bird strikes.

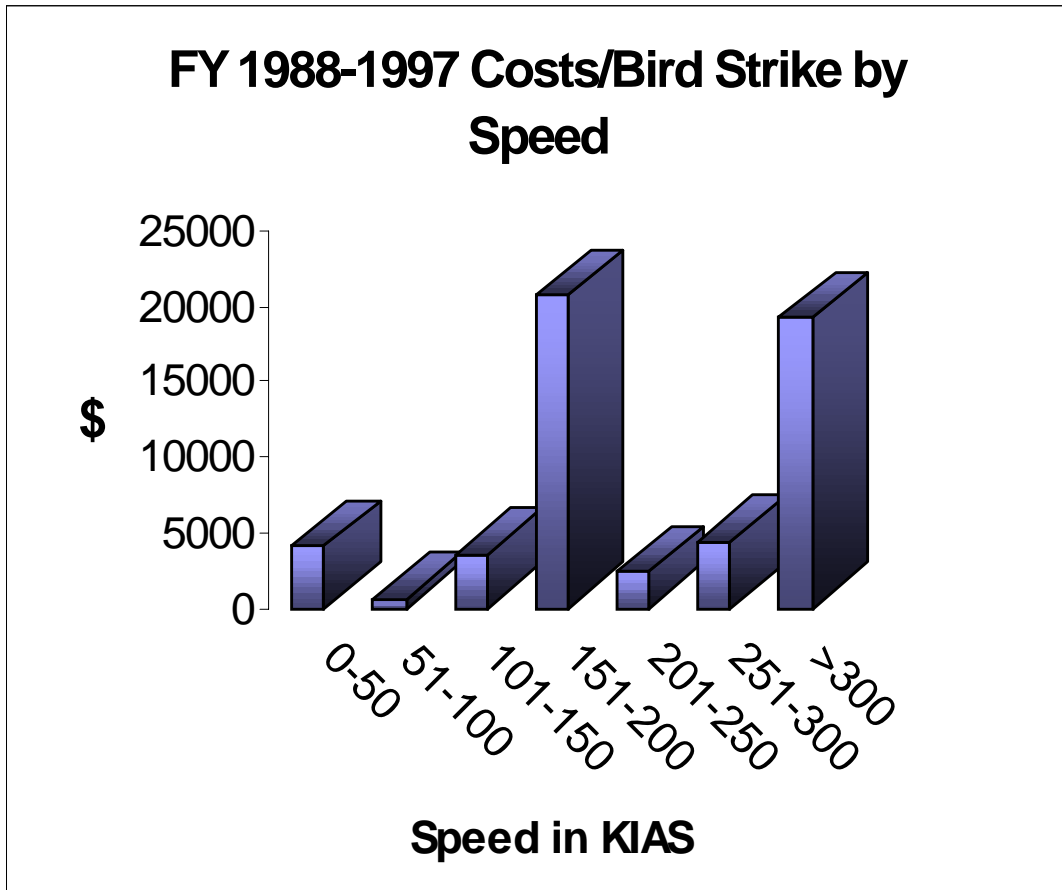

Figure 1.15 USAF costs per bird strike by aircraft speed for FY 1988-1997.

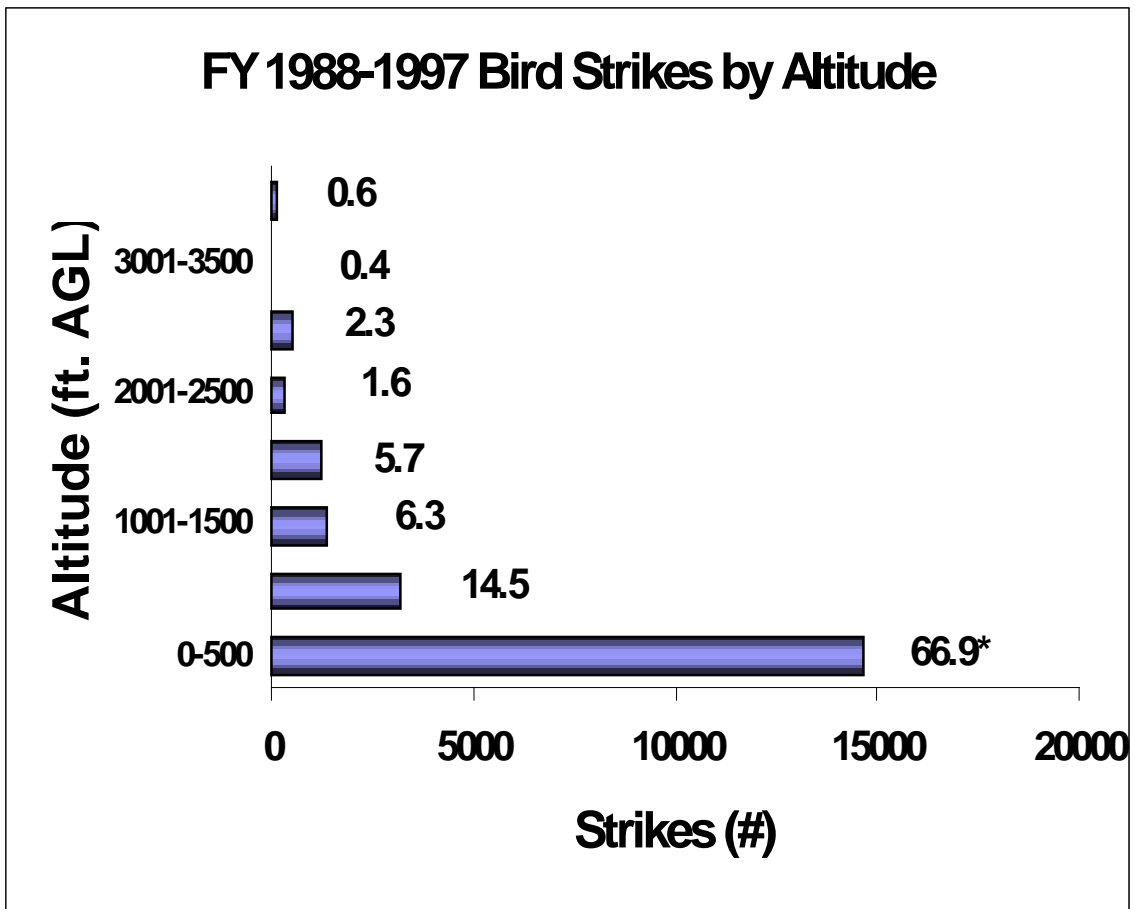

Figure 1.16 USAF bird strikes by aircraft altitude for FY 1988-1997.

* Numbers beside columns represent percent of total bird strikes.

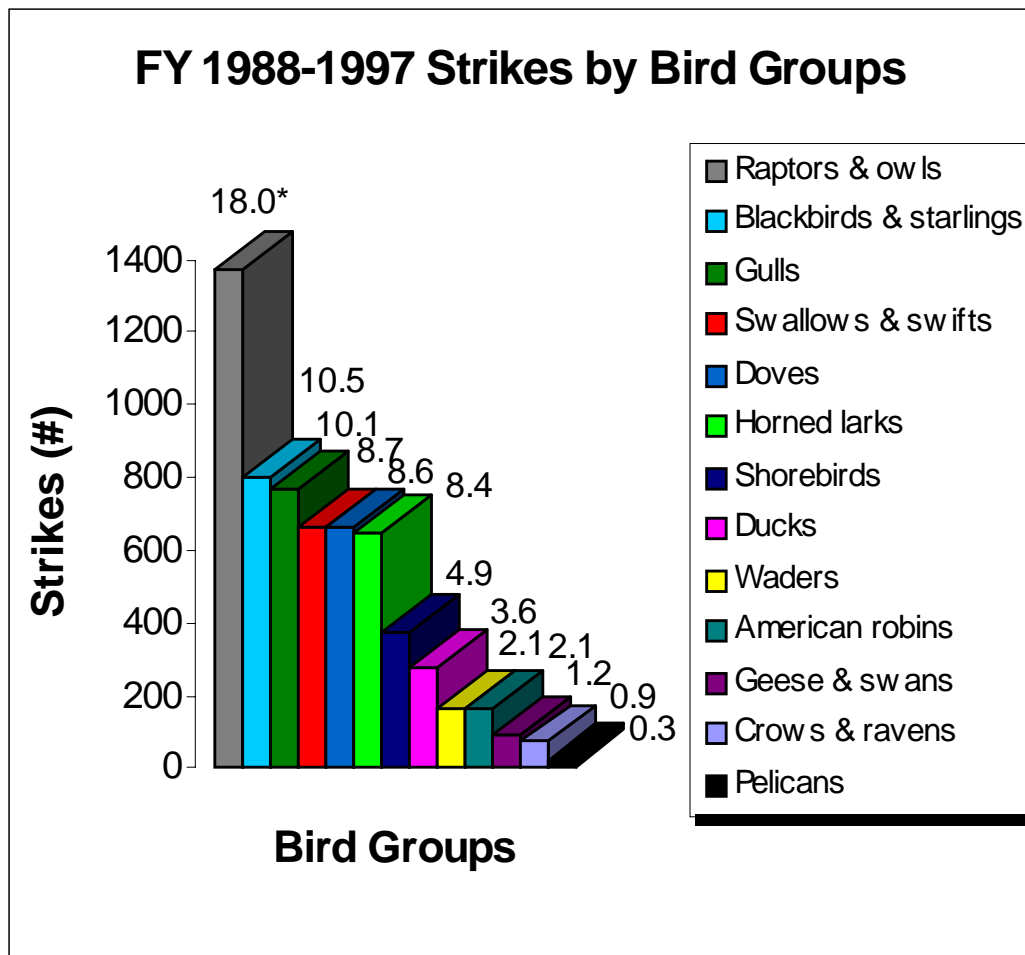

Figure 1.17 USAF bird strikes by bird group for FY 1988-1997.

* Numbers above columns represent percent of total bird strikes.

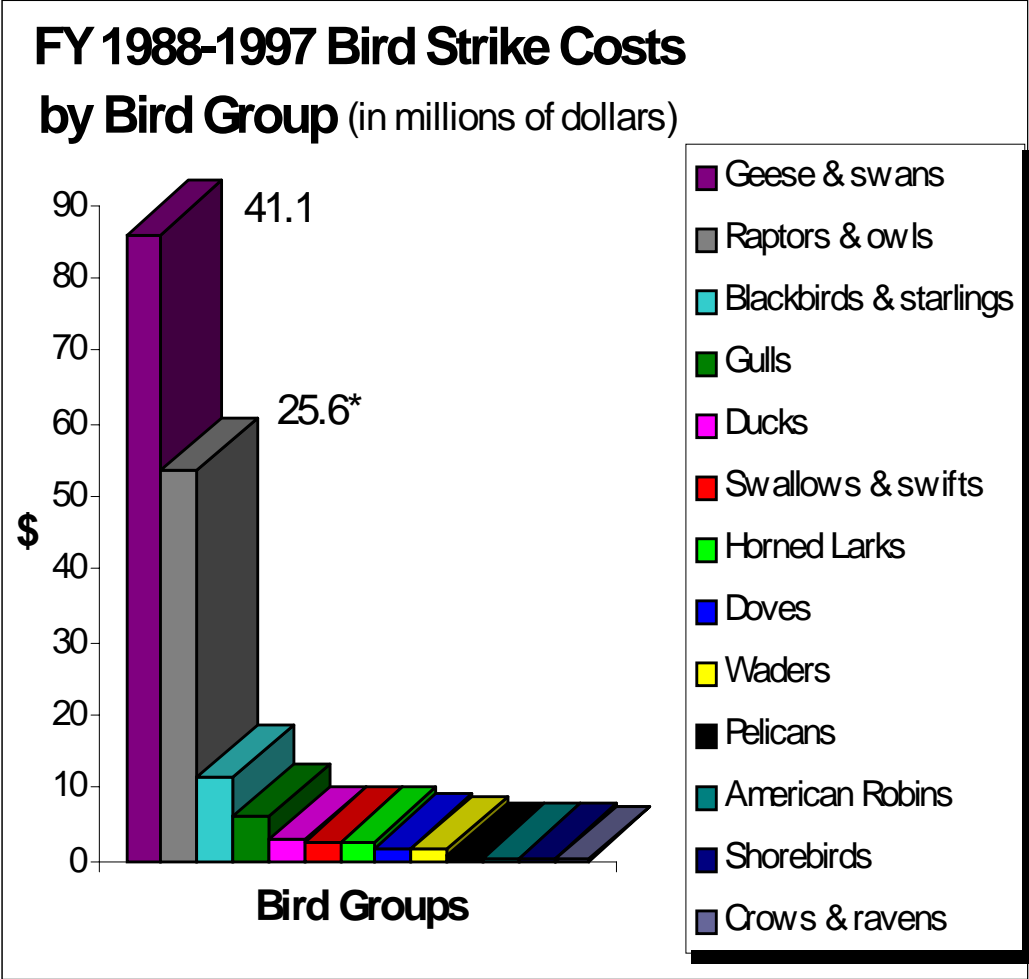

Figure 1.18 USAF bird strike costs by bird group for FY 1988-1997.
 * Numbers above columns represent percent of total bird strikes.

DISCUSSION

My analysis of data on bird strikes to USAF aircraft revealed patterns similar to those observed in Neubauer's (1990) analyses of data for USAF strikes prior to FY 1988. For example, I observed a bimodal distribution of strikes. The two peaks I observed appear to be correlated to bird migration seasons. Migratory birds move seasonally in great flocks. Using North American Breeding Bird Survey data, Peterjohn et al. (1994) estimated that during the 1992 and 1993 fall migration the Mississippi flyway contained 11 million birds. The Pacific (6.5 million), Central (5 million), and Atlantic (3 million) flyways also contained a large number of birds (Lovell 1997*b*). It can be inferred from these data that migration poses an increased hazard to aircraft, particularly in areas along migration routes. The bird strike problem in North America is very serious due to the extreme density of aircraft routes overlapping with bird migration tracks (Neubauer 1990, Langley 1993, MacKinnon 1996*a*).

Both damaging and non-damaging bird strike-related mishaps have occurred at all times of day. However, as was found in Neubauer's (1990) earlier analyses of data on USAF bird strikes, the majority of strikes occurred during the day and when skies were reportedly clear; this also was the period with the highest risk of damage. Aircraft activity generally is greatest during the day and greatest in clear weather. In addition, most bird species are diurnal and more active in clear weather. However, many birds fly at night (especially during migration), as well as during dawn and dusk (MacKinnon 1996*a*). When strikes/hour are calculated using an average day and night length of 11.25 hours and an average dawn and dusk length of 0.75 hours (Cleary et al. 1998), it becomes clear that these other periods also are hazardous with respect to bird strikes. These strike patterns also were observed in analyses of data on bird strikes to civilian aircraft during the period of 1991-1997 (Cleary et al. 1998).

An apparent relationship between phase of flight and aircraft altitude exists, as suggested by patterns in when bird strikes occurred. Consistent with prior analyses of strike data (Neubauer 1990), for the period of FY 1988 through FY 1997 over 75% of the bird strikes occurred during phases of flight that generally take place below 4,000 ft. AGL. About 34% of the bird strikes during this period occurred during take-off and

landing operations. The high number of strikes during take-off and landing can be explained partly by the fact that all aircraft must perform these operations as a part of any mission. It also is explained by the fact that take-off and landing operations occur at low altitude. For instance, aircraft approaching an airfield can be expected to be at a height of about 500 ft. AGL (150 m) when 2 mi. (3 km) from touchdown (Langley 1993). At such low altitudes, aircraft are likely to encounter birds. Gulls, for example, typically fly below 1,000 ft. AGL (305 m) to and from food sources (i.e., landfills near airfields).

An apparent slightly greater number of strikes occurred on landing ($n = 3,669$) than on take-off ($n = 2,842$), as was observed in analyses of bird strikes prior to FY 1988 (Neubauer (1990)). Neubauer suggested that fewer strikes occur on take-off because there is greater noise that alerts birds. In addition, the time it takes an aircraft to go from a stop to take-off speed gives birds a greater chance to react and avoid the aircraft (Neubauer 1990). Landing aircraft are at a more constant speed and lower, quieter engine settings are maintained.

Although high airfield activity and the fact that such activities put aircraft at low altitudes where more birds are present are two possible factors contributing to the high number of bird strikes during airfield operations (take-off, landing, touch-and-go, and missed approach), another contributing factor is that airfields often are attractive to birds. Airfields habitat often contrasts that of surrounding areas and birds are attracted to airfields for food, water, and shelter or cover. If large numbers of birds are present on or near an airfield, the potential for strikes during airfield operations is likely to be high.

When taken collectively, flocking birds were struck more frequently than larger, soaring birds on airfields during airfield operations. Flocking birds such as blackbirds and starlings, gulls, and horned larks often are found on or near airfields. The presence of these birds, coupled with the high number of low-altitude aircraft operations that are typical on or near an airfield, yields the large number of airfield bird strikes. Birds such as raptors, geese and swans, ducks, and pelicans were struck during airfield operations as well as during low-level and range operations. However, the number of strikes on low-level and range operations involving these birds were in many cases greater than the number of airfield strikes involving these birds. Because low-level and range strikes typically were at low altitude and high speed and involved large birds they usually

resulted in damage. The frequency of damaging mishaps on low-level and range operations has been higher in recent years than it was before 1980. The increased frequency presumably is related to the increased proportion of U.S. military flying that has been conducted at low-level in recent years (Richardson 1994).

Relative risks increased with increasing bird weight. Strikes with large birds, and especially those involving flocks, are more likely to result in damage (Allan 1996, MacKinnon 1996*a*). Bird strikes involving raptors, geese, swans, and ducks typically resulted in damage to the aircraft. Conversely, bird strikes involving horned larks, blackbirds, and starlings generally did not result in damage to the aircraft. Nonetheless, the relative risk associated with small birds was slightly higher than that for small to medium birds. This could be due to the fact that birds in the “small” category are flocking birds, and therefore multiple birds often are struck by aircraft. In general, the majority of multiple bird strikes with known phases of flight occurred on the airfield (50.5%, $n = 4,268$).

A significant correlation ($P < 0.05$) was observed between bird strikes and whether landing lights were on for some bird groups. Analyses indicated that the risk of striking owls, swallows and swifts, shorebirds, gulls, and doves may be greater when landing lights are on. Conversely, the risk of striking raptors and waders appears to be reduced when landing lights are on. Lights have been suggested as a potential on-board device to disperse birds from the flight path of approaching aircraft, however, the use of aircraft lights to reduce the bird strikes is not fully evaluated. Although it is reasonable to presume that aircraft landing lights make aircraft more visible and possibly elicit fear or stress response in birds, there is no direct evidence that birds see and avoid aircraft with landing lights on (Buurma 1984). In addition, birds’ response may depend upon several environmental factors such as daylight conditions (Pilo et al. 1994). For instance, during the day, the brightness of landing lights would be markedly reduced. The results described here may simply reflect where these bird groups are struck most often. For instance, raptors are struck more often during low-level operations when landing lights are not on than during airfield operations when landing lights are on. Gulls, on the other hand, are struck more often during airfield operations when landing lights are on.

A large percentage of strikes (approximately 75%) occurred at low aircraft speeds (<200 KIAS). This corresponds to the high number of strikes at low altitudes (in some cases while aircraft were still on the ground) during airfield operations. Generally, aircraft have take-off and landing speeds below 370 km/h or 200 KIAS (Neubauer 1990, FY1988-FY1997 USAF Bird Strike Data).

Speed is highly associated with damage resulting from bird strikes; as speed increases, so does the likelihood of a damaging strike. Because kinetic energy increases with mass and the square of velocity, bird strikes at double the aircraft speed impart 4 times the energy and result in greater damage to aircraft. Consistent with this, my analyses of bird strikes suggested that a bird strike is most likely to produce a damaging outcome when aircraft are on low-level and range operations. An estimated 84.7% of bird strikes at high speeds (>300 KIAS) occurred during low-level and range operations and resulted in aircraft damage. Not surprisingly, aircraft that typically fly low altitude, high-speed operations (fighter/attack and bomber aircraft) are at greater risk of having a damaging bird strike. These aircraft spend much of their flight time below 1,219 m (Neubauer 1990) where birds are more numerous; their high flight speeds increase the likelihood for a strike because pilots have little time to react and increase the likelihood for a strike resulting in damage. As suggested by Neubauer (1990), the relative risk of damage on ranges may be greater than that on low-level because low-level operations tend to be more straight and level than range operations. Therefore, it may be easier for pilots to maintain aircraft orientation and fly out of a bird strike situation when on low-level.

Anterior portions of aircraft were struck more frequently than other portions of the aircraft. The frequency with which the engines, windshield/canopy, wings, and radome/nose were struck during the period of FY 1988 through FY 1997 was similar to that of strikes during the period of FY 1974 through FY 1988 (Neubauer 1990). For both of these periods, the windscreen – specifically, windscreen penetrations – was the only impact site significantly associated with a damaging strike. A bird coming through a windscreen at 556-741 km/h (300-400 KIAS) has the force to hurt or kill a pilot directly (Neubauer 1990). These results re-enforce the need for manufacturers to design aircraft

transparencies and other anterior portions of aircraft (e.g., engines) that can better withstand bird impacts.

SUMMARY

My analyses have indicated that factors contributing to USAF bird strikes overlap and interact. For instance, more bird strikes occur during airfield operations when aircraft are at low altitudes where birds are more numerous. Although factors such as aircraft altitude certainly contribute to the occurrence of a bird strike, they are not necessarily useful in predicting whether the strike will be damaging. Certain factors (and the interaction of these factors) increase the risk of the occurrence of a damaging bird strike. Aircraft speed, phase of flight, bird group (or bird weight), and aircraft group clearly are the strongest predictors of a damaging bird strike. For instance, the risk of damage due to bird strikes is high for bomber aircraft because they fly low-altitude, high-speed missions.

CHAPTER 2

AIRCRAFT AND AIRFIELD RISK ASSESSMENTS

INTRODUCTION

Relative risks of damage for categories of variables were calculated based on data on bird strikes, however, this alone can not give an accurate account of the bird strike problem or strike risk. First, these initial analyses do not account for the increased risk that would result given a combination of the variables contributing to bird strikes. Second, the odds of a bird strike (damaging or non-damaging) occurring is not only a function of a combination of the variables included in the strike data (e.g., aircraft group, aircraft speed, aircraft altitude), but also a function of the number of times an aircraft passes through a given volume of airspace (Allan 1996). Counting the number of bird strikes per year at an airfield or to an aircraft and correcting for movement/flight hours also is important. Hence, the odds of a damaging bird strike occurring on/near an airfield can be estimated by examining the analyses of data on bird strikes and USAF reported aircraft flight hours and airfield movements. The USAF can use these estimates to assess the severity of bird strike problems at different bases and evaluate the effectiveness of existing bird management programs.

The odds of a bird strike occurring also are a function of the density of birds in a given airspace. However, correct data on the variation of the amount of bird mass per unit volume of air hardly exist (Buurma 1984). Consequently, it is beyond the scope of the present study to include bird density data in statistical analyses. Nevertheless, bird densities may be indirectly reflected in odds ratios computed from the bird strike data. For instance, the odds of damage for strikes involving small birds may be somewhat higher than expected because many small birds typically are struck simultaneously because they often are located on/near airfields in large flocks.

Calculation of low-level bird strike rates originally was a goal of the present study. The Military Airspace Management Systems (MASMS) at Offutt AFB, NE was contacted to obtain FY 1994 through FY 1997 flight hours for USAF low-level routes. MASMS has tracked flight hours for only some of the routes in the United States; other route flight hours, if tracked, are tracked on a local basis. MASMS personnel voiced reservation as to whether data were accurate enough to be used for the purposes of the present study. In short, data on low-level flight hours were not sufficient to allow for

calculation of low-level route bird strike rates. In addition, data on bird strikes also were determined not to be sufficient to allow for calculation of low-level route bird strike rates. Bird strikes reported as having occurred during low-level operations did not always include information on the specific low-level route that was flown, and therefore the number of bird strikes per low-level route could not be determined accurately.

The **objectives** of this portion of my study were to:

1. assess the risk of a bird strike to USAF aircraft by examining the number of bird strikes that occurred to each aircraft type and aircraft group relative to the number of hours flown,
2. assess the risk of a bird strike at select USAF airfields by examining the number of bird strikes relative to the number of movements on those airfields,
3. compute the odds of occurrence for a damaging airfield bird strike for specific combinations of all strike variables,
4. use calculated airfield strike rates, the odds of occurrence for a damaging airfield bird strike incident, and general statistics to compare select USAF airfields and identify those with higher bird strike risks.

METHODS

Aircraft Bird Strike Incident Rates

I collected USAF aircraft flight hours for the period of FY 1994 through FY 1997 from the USAF Safety Center at Kirtland AFB, NM. I pooled together flight hours for major groups of aircraft types as follows: C-135 totals included flight hours for all models of C-135, EC-135, KC-135, RC-135, TC-135, and WC-135 aircraft; C-130 totals included flight hours for all models of C-130, AC-130, EC-130, HC-130, KC-130, MC-130, and WC-130 aircraft; F-111 totals included flight hours for all models of F-111 and EF-111 aircraft; T-38 totals included flight hours for all models of T-38 and AT-38 aircraft; A-10 totals included flight hours for all models of A-10 and OA-10 aircraft; and A-37 totals included flight hours for all models of A-37 and OA-37 aircraft.

From the data on bird strikes, I calculated the yearly number of strikes for each type of aircraft for the period of FY 1988 through FY 1997 using Microsoft Access 97 (Microsoft Corporation 1996). Mean and yearly aircraft strike rates then were estimated and expressed as the number of bird strikes per 10,000 flight hours. These rates also were computed for aircraft groups (i.e., fighter/attack, cargo/airlift/transport, bomber, trainer, and reconnaissance).

Airfield Bird Strike Incident Rates

I collected data on airfield movements for all USAF airfields (bases) for FY 1994 through FY 1997 from the Air Force Flight Standards Agency (AFFSA) at Andrews AFB, MD. USAF base totals included all military, general aviation, and commercial IFR arrivals (landing operations), IFR departures (take-off operations), VFR locals (missed approach and touch and go operations), and VFR ITENs (traffic in the area that contacted the tower). With the exception of Howard AFB, Panama, I selected only USAF airfields in North America for analysis. I then further limited my analysis to airfields that had a mean of at least 45,000 airfield movements for the period of FY 1994 through FY 1997.

From the data on bird strikes, I computed the number of annual airfield bird strikes for these USAF bases using Microsoft Access 97 (Microsoft Corporation 1996). Totals included all strikes that occurred during landing, take-off, missed approach, and touch and go operations. Because missed approach and touch and go operations each are comprised of two separate movements, I doubled the total number of bird strikes for these specific movements. Mean and yearly strike rates then were calculated and expressed as the number of strikes per 10,000 airfield movements. There is no phase of flight category in the bird strike database corresponding to VFR ITEN counts included in airfield movement totals. This initially was considered a problem because the VFR ITEN counts could not be identified and removed from totals. However, for the purpose of the present study, AFFSA considered the VFR ITEN counts to be negligible with respect to total airfield movements. Including these counts did not considerably affect calculated strike rates.

Logistic Regression Analysis

Logistic regression analysis is a multivariate technique useful in predicting whether an event will occur based on values of a set of predictor variables. It is similar to a linear regression model, but is best suited to models where the dependent variable is dichotomous. Logistic regression coefficients can be used to estimate odds ratios for combinations of the independent variables in the model (SPSS Inc. 1997).

Using independent variables that previously were found (using the GLM General Factorial procedure) to be statistically significant with respect to damage, I used the SPSS Logistic Regression Analysis procedure (SPSS Inc. 1997, SPSS Inc. 1998) to predict the odds of occurrence for a damaging bird strike (on/near USAF airfields). I first entered damage as the categorical dependent variable and then entered the following independent variables as categorical covariates: base, aircraft group, aircraft speed, aircraft altitude, time of day, landing lights on, Julian date, and bird size. I only included airfield bird strikes (i.e., bird strikes that occurred on landing, take-off, missed approach, and touch-and-go operations) in the analyses. In addition, I limited logistic regression analyses to complete bird strike records (i.e., records containing verified values for all independent

variables, $n = 1,842$). I made this limitation to ensure that sample size was equal for all logistic regression analyses so that changes in the -2 (log likelihood) statistics could be compared to the goodness of fit of models.

I ran the initial logistic regression analysis with all independent variables using the forward LR method of model selection. By using the forward LR method, only the base and aircraft variables remained in the model. I included these variables in all subsequent analyses, but I did not choose a method of model selection. Instead, I systematically added other variables and looked at the -2 (log likelihood) statistics SPSS 8.0 computed for resulting models. The difference in -2 (log likelihood) statistics has an approximate Chi-square distribution with degrees of freedom equal to the difference in the number of parameters in the models (Stokes et al. 1995). By comparing the likelihood ratio – the change in the -2 (log likelihood) statistics for models – I was able to determine if including additional variables significantly improved prior models. The best model included the variables base, aircraft group, speed, and bird size. The following variables did not significantly ($P < 0.05$) improve the model: aircraft altitude, time of day, Julian date or month, and landing lights on.

Once the variables to be included in the model had been identified, I again performed logistic regression analyses to determine if including interactions of these variables or powers of these variables would improve the model. The model was not improved. Again, I performed logistic regression analysis, but I included only the 4 variables base, aircraft group, speed, and bird size. In addition, to increase sample size for this analysis, I included airfield bird strike records that were complete with respect to the 4 independent variables in the model ($n = 2,295$). Setting the classification cutoff value according to the ratio of damaging to total airfield strikes (0.04) increased the capability of the model to correctly predict bird strikes as damaging or non-damaging.

I then entered SPSS logistic regression output into Microsoft Excel 97 and calculated the odds of a bird strike being damaging based on different combinations of the values of the predictor variables (Microsoft Corporation 1996). I looked for general trends for aircraft groups, aircraft speeds, bird sizes, and airfields using calculated airfield strike rates, the odds of occurrence for a damaging airfield bird strike incidents, and general statistics.

RESULTS

Aircraft Bird Strike Incident Rates

For the period of FY 1994 through FY 1997, cargo/airlift/transport aircraft flew the most hours (n = 9,879,817), followed by fighter/attack aircraft (n = 8,781,362), trainer aircraft (n = 4,948,438), bomber aircraft (n = 870,511), and reconnaissance aircraft (n = 539,210). Regarding the number of bird strikes, the same order was observed. Cargo/airlift/transport aircraft had the greatest number of bird strikes (n = 5,221), followed by fighter/attack aircraft (n = 1,948), trainer aircraft (n = 1,179), bomber aircraft (n = 702), and reconnaissance aircraft (n = 279, Table 2.1). Aircraft with the highest number of bird strikes during this period included C-130s (n = 2,182), C-135s (n = 1,816), F-16s (n = 955), T-38s (n = 645), C-141s (n = 613), F-15s (n = 449), and T-37s (n = 443, Table 2.2).

The bomber aircraft group had the highest bird strike rate (8.1 strikes per 10,000 flight hours). Analyses by aircraft revealed that B-2 (152.0) and B-52 (37.0) bombers had the highest bird strike rate. The B-1 bomber also had a relatively high bird strike rate compared to most of the aircraft included in analyses (18.0). Cargo/airlift/transport aircraft had the next highest bird strike rate (5.3). The aircraft that largely accounted for this rate were C-17s (25.9), C-135s (21.0), and C-130s (19.3). Reconnaissance aircraft had a strike rate of 5.2. Trainer and fighter/attack aircraft had relatively low bird strike rates (2.4 and 2.2, respectively) compared to other aircraft groups that were analyzed. Within these groups, T-39s (17.0) and F-111s (15.3) struck the most birds relative to the number of hours that were flown (Tables 2.3 and 2.4),

Airfield Bird Strike Incident Rates

For the period of FY 1988 through FY 1997, the most movements (n = 188,033) were flown at Randolph followed by Luke (n = 183,163), Tyndall (n = 180,229), Eglin (n = 152,825), Holloman (n = 137,285), and Edwards (n = 120,775, Table 2.5). Analyses of airfield bird strikes with respect to a sample of all USAF bases revealed that bases at

which training was the central mission, incurred the greatest number of strikes (Tables 2.6 and 2.7). Of those training bases analyzed, Altus (n = 278) had the greatest number of bird strikes followed by Randolph (n = 200), Laughlin (n = 198), Luke (n = 191), Columbus (n = 187), Vance (n = 177), and Sheppard (n = 163). Barksdale (n = 171) also had a relatively large number of strikes as did Howard (n = 158) and Little Rock (n = 142).

Of the bases included in analyses, Howard (6.4) had the highest airfield bird strike rate (Table 2.8). Altus, Barksdale, McConnell, and Kelly all had airfield bird strike rates >3.00. Analyzed by major command, AETC had the highest mean airfield bird strike rate (n = 8, SE = 0.47). The AMC bases analyzed had a mean bird strike rate of 2.03 (n = 5, SE = 0.51). The ACC bases analyzed had a mean bird strike rate of 1.67 (n = 11, SE = 0.57). Excluding Howard, the mean bird strike rate for the ACC bases analyzed was 1.19 (n = 10, SE = 0.35). The AFMC bases analyzed had a mean bird strike rate of 1.35 (n = 5, SE = 0.53). Elmendorf AFB, AK was the only PACAF base included in analyses and had a low bird strike rate (0.2). Patrick AFB, FL was the only AFSPC base included in analyses and had a bird strike rate of 1.4.

Logistic Regression

The best logistic regression model contained the variables base, aircraft group, bird size, and aircraft speed (n = 2,295, df = 45, df = 5, -2 (log likelihood) = 643.51, -2 (log likelihood) = 14.23). With a cutoff value of 0.04, the model correctly predicted 72.5% of non-damaging bird strikes. It correctly predicted 75.0% of the damaging bird strikes. Overall, in terms of damage the model correctly predicted 72.6% of the bird strikes.

Analyses of logistic regression output provided odds ratios for different combinations of the values of the predictor variables and revealed some general trends in airfield bird strikes with respect to damage (Tables 2.9-2.23). Given the same base, aircraft, and bird size, the odds of a damaging strike occurring on/near the airfield generally increased with aircraft speed (Table 2.24). There were two exceptions, however. The odds of a damaging strike were greater at 0-50 KIAS than the odds for all

but two speed categories (201-250 KIAS and >300 KIAS). The odds of a damaging strike were lower at 251-300 KIAS than the odds for all but one speed category (51-100 KIAS).

Another trend observed through analyses of the logistic regression output was that, given the same base, aircraft, and aircraft speed, airfield strikes involving large birds were more likely to result in damage than those involving smaller birds (Table 2.25). In addition, logistic regression analyses indicated that trainer aircraft had the greatest odds of incurring a damaging strike on/near the airfield, followed by bomber, cargo/airlift/transport, fighter/attack, and reconnaissance aircraft (Table 2.26).

Of USAF bases that had airfield bird strike rates ≥ 2.0 , those with the greatest odds of damage were Tinker followed by Dover, Howard, Kelly, Barksdale, and Laughlin. Altus, McConnell, and Sheppard had negligible odds (< 0.005) of a damaging bird strike occurring on/near the airfield.

Of USAF bases that had airfield bird strike rates < 2.0 and ≥ 1.0 , those with the greatest odds of damage were Randolph, Beale, Edwards, Luke, Travis, Dyess, and Patrick. McGuire, Little Rock, Davis-Monthan, Columbus, and Vance had negligible odds (< 0.005) of a damaging bird strike occurring on/near the airfield.

Of USAF bases that had airfield bird strike rates < 1.0 , those with the greatest odds of damage were Shaw, Elmendorf, Seymour-Johnson, Eglin, and Tyndall. Pope, Hill, and Nellis had negligible odds (< 0.005) of a damaging bird strike occurring on/near the airfield.

In general, the odds of a damaging airfield bird strike were not greatest for USAF bases that had the highest bird strike rates. Although Shaw had one of the lowest bird strike rates (0.2) of the USAF bases analyzed, it had the greatest odds of having a damaging airfield bird strike. Elmendorf also had a relatively low bird strike rate (0.2) and a high odds ratio with respect to damage. Relative to other bases analyzed, the odds of damage also were high for Tinker, Seymour-Johnson, Dover, and Howard (Table 2.27). Of the AETC bases included in analyses, Randolph had the greatest odds ratio. Of the ACC bases included in analyses, aside from Howard, Barksdale had the highest bird strike rates and the greatest odds of having a damaging airfield bird strike (Table 2.28).

CHAPTER 2 TABLES AND FIGURES

Table 2.1 Damaging ($\geq \$10,000$) and non-damaging ($< \$10,000$) USAF bird strikes during airfield operations by aircraft group for FY 1994-1997.

Aircraft Group	Damaging ^a	Non-damaging ^a	Total ^b
Cargo/airlift/transport	2.2 (117)	97.8 (5,104)	5,221
Fighter/attack	4.0 (78)	96.0 (1,870)	1,948
Trainer	3.6 (43)	96.4 (1,136)	1,179
Bomber	8.5 (60)	91.5 (642)	702
Reconnaissance	0.4 (1)	99.6 (278)	279

^a First number represents percent of total strikes within aircraft group, followed by number of strikes.

^b $n = 9,328$ ($\bar{x} = 1,866$), $n = 299$ damaging ($\bar{x} = 60$), $n = 9,029$ non-damaging ($\bar{x} = 1,806$).

Table 2.2 Damaging ($\geq \$10,000$) and non-damaging ($< \$10,000$) USAF bird strikes during airfield operations by aircraft for FY 1994-1997.

Aircraft	Damaging^a	Non-damaging^a	Total^b
C -130	1.7 (37)	98.3 (2,145)	2,182
C -135	1.2 (21)	98.8 (1,795)	1,816
F -16	4.1 (39)	95.9 (916)	955
T -38	5.4 (35)	94.6 (610)	645
C -141	3.9 (24)	96.1 (589)	613
F -15	8.7 (39)	91.3 (410)	449
T -37	0.7 (3)	99.3 (440)	443
B -52	4.9 (19)	95.1 (367)	386
A -10	3.3 (12)	96.7 (350)	362
C -5	4.0 (10)	96.0 (238)	248
C -21	7.0 (14)	93.0 (185)	199
C -9	0.0 (0)	100.0 (191)	191
B -1	16.8 (30)	83.2 (149)	179
C -17	6.9 (11)	93.1 (149)	160
B -2	8.0 (11)	92.0 (126)	137
F -111	3.2 (4)	96.8 (122)	126
E -3	1.2 (1)	98.8 (84)	85
T -43	0.0 (0)	100.0 (64)	64
F -4	0.0 (0)	100.0 (17)	17
C -12	0.0 (0)	100.0 (12)	12
F -117	0.0 (0)	100.0 (12)	12
U -2	0.0 (0)	100.0 (9)	9
T -39	0.0 (0)	100.0 (6)	6
C -20	0.0 (0)	100.0 (5)	5
C -18	0.0 (0)	100.0 (4)	4
RF -4	0.0 (0)	100.0 (4)	4
A -37	0.0 (0)	100.0 (1)	1
C -23	0.0 (0)	100.0 (1)	1

^a First number represents percent of total strikes within aircraft type, followed by number of strikes.

^b $n = 9,311$ ($\bar{x} = 333$), $n = 310$ damaging ($\bar{x} = 11$), $n = 9,001$ non-damaging ($\bar{x} = 321$).

Table 2.3 USAF aircraft group bird strike rates (per 10,000 flight hours) for FY 1994-1997.

Aircraft Group	Strike Rate
Bomber	8.1
Cargo/airlift/transport	5.3
Reconnaissance	5.2
Trainer	2.4
Fighter/attack	2.2

Table 2.4 USAF aircraft type bird strike rates (per 10,000 flight hours) for FY 1994-1997.

Aircraft	FY 1994	FY 1995	FY 1996	FY 1997	Mean Rate
B -2	81.97	161.49	160.10	160.07	152.0
B -52	27.06	37.98	48.62	36.83	36.9
C -17	31.43	11.57	27.55	31.21	25.9
C -135	17.52	21.69	24.22	20.47	21.0
C -9	13.55	20.29	22.36	21.33	19.3
C -130	16.65	19.16	19.79	21.47	19.3
B -1	14.97	19.44	13.27	28.64	18.0
T -39	7.53	32.63	39.47	0.00	17.0
F -111	13.25	15.99	22.58	6.39	15.3
C -18	8.13	15.13	35.84	0.00	13.7
A -37	0.00	36.63	0.00	0.00	13.7
T -43	4.24	13.89	22.85	4.58	11.6
C -141	7.19	9.87	15.91	10.78	11.1
C -21	8.66	9.36	17.30	7.60	10.7
T -38	8.03	10.67	10.45	10.57	9.8
C -5	7.96	13.93	9.48	5.70	9.3
E -3	9.43	8.98	4.91	12.41	8.8
T -37	6.59	10.19	7.01	6.46	7.5
A -10	4.19	7.76	7.40	8.59	7.0
C -23	18.48	0.00	0.00	0.00	6.9
F -16	5.12	4.17	6.49	9.54	6.3
F -15	6.28	3.73	5.83	5.56	5.3
RF -4	6.94	0.00	0.00	0.00	4.0
F -4	4.23	1.43	3.35	7.55	3.2
C -12	0.00	0.93	17.41	4.35	2.6
F -117	0.00	1.56	1.52	6.13	2.4
C -20	4.53	3.09	0.00	0.00	1.9
U -2	2.56	0.56	0.61	2.50	1.5

Table 2.5 Airfield movements^a by USAF airfield for FY 1994-1997.

USAF Airfield	FY 1997	FY 1996	FY 1995	FY 1994	Mean
Randolph AFB, TX	125,281	147,813	139,536	191,688	188,033
Luke AFB, AZ	149,386	133,584	161,431	154,666	183,163
Tyndall AFB, FL	131,658	139,231	162,842	147,955	180,229
Eglin AFB, FL	115,419	110,700	141,301	133,179	152,825
Holloman AFB, NM	89,640	96,283	118,786	148,149	137,285
Edwards AFB, CA	78,841	93,348	93,348	124,215	120,775
Little Rock AFB, AR	75,573	93,647	127,088	68,752	114,677
Travis AFB, CA	87,878	86,881	77,652	81,951	105,311
Altus AFB, OK	76,258	84,960	71,154	62,426	94,940
Davis-Monthan AFB, AZ	61,611	56,263	85,896	98,098	89,533
Sheppard AFB, TX	106,512	85,544	41,414	34,634	88,412
Tinker AFB, OK	59,527	69,941	65,014	76,238	85,165
Elmendorf AFB, AK	59,169	60,212	76,167	80,701	84,115
Nellis AFB, NV	71,124	66,965	61,160	66,868	83,271
Columbus AFB, MS	58,380	66,992	73,084	64,688	82,534
McChord AFB, WA	60,004	63,877	59,231	74,676	80,416
Laughlin AFB, TX	78,158	57,089	56,071	72,501	80,227
McGuire AFB, NJ	60,144	57,402	78,406	34,463	71,954
Hill AFB, UT	46,433	55,338	62,238	60,984	70,083
McConnell AFB, KS	45,111	53,452	67,075	57,249	69,085
Seymour-Johnson AFB, NC	53,517	52,702	58,513	58,508	68,986
Patrick AFB, FL	48,457	46,742	59,440	72,856	68,559
Pope AFB, NC	48,941	62,834	70,518	20,395	66,381
Dyess AFB, TX	44,861	59,332	68,159	27,112	64,699
Kelly AFB, TX	44,829	44,080	60,013	61,811	63,703
Beale AFB, CA	47,938	44,842	51,476	63,705	63,201
Dover AFB, DE	48,614	45,315	50,476	57,948	61,917
Shaw AFB, SC	42,135	44,203	50,324	64,032	61,224
Vance AFB, OK	65,218	43,824	30,272	60,735	60,968
Howard AFB, Panama	31,728	39,024	35,562	55,710	50,262
Barksdale AFB, LA	47,540	23,372	62,221	27,463	45,992

^a Airfield movements include take-off, landing, touch-and-go, and missed approach operations.

Table 2.6 Damaging ($\geq \$10,000$) and non-damaging ($< \$10,000$) USAF bird strikes during airfield operations by USAF airfield for FY 1994-1997.

USAF Airfield	Damaging^a	Non-damaging^a	Total^b
Altus AFB, OK	0.4 (1)	99.6 (277)	278
Randolph AFB, TX	10.5 (21)	89.5 (179)	200
Laughlin AFB, TX	7.1 (14)	92.9 (184)	198
Luke AFB, AZ	1.0 (2)	99.0 (189)	191
Columbus AFB, MS	3.7 (7)	96.3 (180)	187
Vance AFB, OK	4.0 (7)	96.0 (170)	177
Barksdale AFB, LA	0.6 (1)	99.4 (170)	171
Sheppard AFB, TX	4.9 (8)	95.1 (155)	163
Howard AFB, Panama	4.4 (7)	95.6 (151)	158
Little Rock AFB, AR	0.7 (1)	99.3 (141)	142
McConnell AFB, KS	1.7 (2)	98.3 (116)	118
Dover AFB, DE	5.9 (6)	94.1 (95)	101
Davis-Monthan AFB, AZ	1.1 (1)	98.9 (94)	95
Seymour-Johnson AFB, NC	2.2 (2)	97.8 (89)	91
Tinker AFB, OK	1.1 (1)	98.9 (88)	89
Kelly AFB, TX	4.8 (4)	95.2 (79)	83
Beale AFB, CA	10.4 (8)	89.6 (69)	77
Travis AFB, CA	2.6 (2)	97.4 (75)	77
Dyess AFB, TX	3.0 (2)	97.0 (65)	67
Patrick AFB, FL	4.6 (3)	95.4 (62)	65
McChord AFB, WA	0.0 (0)	100.0 (60)	60
McGuire AFB, NJ	6.0 (3)	94.0 (47)	50
Eglin AFB, FL	6.4 (3)	93.6 (44)	47
Edwards AFB, CA	2.2 (1)	97.8 (45)	46
Tyndall AFB, FL	4.5 (2)	95.5 (42)	44
Holloman AFB, NM	3.1 (1)	96.9 (31)	32
Pope AFB, NC	6.5 (2)	93.5 (29)	31
Shaw AFB, SC	4.0 (1)	96.0 (24)	25
Elmendorf AFB, AK	8.7 (2)	91.3 (21)	23
Nellis AFB, NV	0.0 (0)	100.0 (23)	23
Hill AFB, UT	0.0 (0)	100.0 (19)	19
Other	2.7 (135)	97.3 (4,813)	4,948

^a First number represents percent of total strikes within base, followed by number of strikes.

^b For the 31 USAF bases listed: $n = 3,128$ ($\bar{x} = 101$), $n = 115$ damaging ($\bar{x} = 4$), $n = 3,013$ non-damaging ($\bar{x} = 97$).

Table 2.7 Percentage of USAF bird strikes each month for USAF airfields for FY 1994-1997.

Base	Jan	Feb	Mar	Apr	May	June	July	Aug	Sep	Oct	Nov	Dec	Total
Howard AFB, Panama	0.6% ^a	1.9%	6.3%	5.7%	9.5%	12.7%	4.4%	7.0%	13.9%	18.4%	14.6%	5.1%	158
Altus AFB, OK	3.2%	2.2%	2.9%	9.0%	9.0%	11.9%	18.3%	14.4%	12.9%	10.8%	2.5%	2.9%	278
Barksdale AFB, LA	3.5%	4.7%	4.7%	9.4%	11.1%	8.8%	12.3%	9.4%	12.9%	12.9%	6.4%	4.1%	171
Laughlin AFB, TX	6.1%	4.0%	5.6%	9.6%	7.1%	8.1%	8.6%	7.6%	9.1%	29.3%	2.5%	2.5%	198
McConnell AFB, KS	0.0%	4.5%	2.7%	16.2%	18.9%	5.4%	10.8%	11.7%	19.8%	5.4%	0.9%	3.6%	111
Kelly AFB, TX	1.2%	3.6%	9.6%	13.3%	6.0%	7.2%	10.8%	18.1%	15.7%	6.0%	4.8%	3.6%	83
Dover AFB, DE	4.0%	0.0%	3.0%	11.9%	11.9%	4.0%	7.9%	17.8%	5.0%	20.8%	6.9%	6.9%	101
Sheppard AFB, TX	4.3%	3.1%	9.2%	19.0%	15.3%	9.8%	11.7%	5.5%	5.5%	6.7%	7.4%	2.5%	163
Tinker AFB, OK	3.4%	3.4%	5.6%	9.0%	20.2%	13.5%	9.0%	13.5%	13.5%	5.6%	2.2%	1.1%	89
Davis-Monthan AFB, AZ	1.1%	4.2%	5.3%	9.5%	11.6%	5.3%	6.3%	26.3%	12.6%	6.3%	8.4%	3.2%	95
McGuire AFB, NJ	2.0%	2.0%	2.0%	0.0%	2.0%	2.0%	8.0%	48.0%	26.0%	6.0%	0.0%	2.0%	50
Columbus AFB, MS	6.4%	9.6%	8.6%	6.4%	11.2%	8.6%	13.9%	4.8%	7.5%	9.1%	9.6%	4.3%	187
Randolph AFB, TX	4.0%	4.0%	9.5%	5.5%	10.5%	9.5%	11.0%	17.0%	12.0%	8.5%	3.0%	5.5%	200
Luke AFB, AZ	13.6%	8.4%	3.7%	6.8%	7.3%	1.6%	9.9%	13.1%	2.6%	8.4%	11.5%	13.1%	191
Dyess AFB, TX	0.0%	3.0%	7.5%	7.5%	9.0%	10.4%	16.4%	9.0%	13.4%	11.9%	6.0%	6.0%	67
Little Rock AFB, AR	4.2%	2.8%	9.2%	7.7%	7.0%	4.2%	13.4%	8.5%	19.0%	14.8%	7.0%	2.1%	142
Vance AFB, OK	2.8%	2.3%	7.3%	10.2%	14.7%	13.0%	10.7%	10.2%	5.6%	8.5%	10.2%	4.5%	177
Beale AFB, CA	1.3%	3.9%	7.8%	7.8%	7.8%	9.1%	16.9%	7.8%	3.9%	19.5%	9.1%	5.2%	77
Travis AFB, CA	14.3%	6.5%	10.4%	5.2%	6.5%	1.3%	2.6%	2.6%	13.0%	6.5%	24.7%	6.5%	77
Patrick AFB, FL	8.1%	3.2%	1.6%	6.5%	12.9%	8.1%	6.5%	19.4%	6.5%	12.9%	4.8%	9.7%	62
Edwards AFB, CA	12.5%	2.1%	2.1%	2.1%	4.2%	12.5%	6.3%	4.2%	10.4%	39.6%	4.2%	0.0%	48
McChord AFB, WA	0.0%	1.7%	6.9%	5.2%	10.3%	6.9%	15.5%	13.8%	13.8%	3.4%	13.8%	8.6%	58
Seymour-Johnson AFB, NC	3.3%	4.4%	5.5%	13.2%	12.1%	5.5%	4.4%	9.9%	13.2%	18.7%	5.5%	4.4%	91
Pope AFB, NC	0.0%	0.0%	6.9%	3.4%	17.2%	3.4%	10.3%	3.4%	17.2%	13.8%	17.2%	6.9%	29
Tyndall AFB, FL	4.5%	4.5%	4.5%	4.5%	4.5%	4.5%	11.4%	15.9%	9.1%	11.4%	6.8%	18.2%	44
Hill AFB, UT	4.8%	9.5%	4.8%	14.3%	0.0%	19.0%	4.8%	9.5%	19.0%	9.5%	4.8%	0.0%	21
Holloman AFB, NM	15.6%	3.1%	3.1%	6.3%	12.5%	9.4%	18.8%	9.4%	12.5%	6.3%	3.1%	0.0%	32
Eglin AFB, FL	6.4%	2.1%	6.4%	8.5%	2.1%	12.8%	6.4%	6.4%	12.8%	19.1%	12.8%	4.3%	47
Elmendorf AFB, AK	4.3%	0.0%	0.0%	8.7%	13.0%	4.3%	47.8%	4.3%	17.4%	0.0%	0.0%	0.0%	23
Nellis AFB, NV	45.8%	0.0%	0.0%	8.3%	0.0%	4.2%	0.0%	4.2%	25.0%	8.3%	0.0%	4.2%	24
Shaw AFB, SC	4.4%	3.2%	8.9%	10.8%	10.1%	11.4%	10.8%	10.8%	12.7%	6.3%	6.3%	4.4%	158

Table 2.8 USAF airfield bird strike rates (per 10,000 airfield movements) for FY 1994-1997.

Base	MAJCOM	FY 1994	FY 1995	FY 1996	FY 1997	Mean Rate
Howard AFB, Panama	ACC	4.1	4.8	8.5	17.7	6.4
Barksdale AFB, LA	ACC	6.9	0.3	6.9	7.4	3.9
Davis-Monthan AFB, AZ	ACC	0.8	3.5	1.8	2.8	1.8
Dyess AFB, TX	ACC	2.2	2.2	0.8	2.5	1.4
Little Rock AFB, AR	ACC	1.8	1.1	1.8	2.8	1.4
Beale AFB, CA	ACC	2.7	1.8	0.5	1.5	1.4
Seymour-Johnson AFB, NC	ACC	0.0	0.2	1.0	2.2	0.7
Pope AFB, NC	ACC	2.5	0.7	0.3	0.6	0.6
Holloman AFB, NC	ACC	0.4	0.2	0.4	0.8	0.4
Nellis AFB, NV	ACC	0.0	0.0	0.5	0.6	0.2
Shaw AFB, SC	ACC	0.0	0.6	0.2	0.2	0.2
Altus AFB, OK	AETC	2.9	6.3	7.3	5.9	4.5
Laughlin AFB, TX	AETC	2.8	6.4	1.8	6.3	3.6
Sheppard AFB, TX	AETC	4.9	7.0	1.9	1.2	2.1
Columbus AFB, MS	AETC	3.3	1.6	2.5	0.7	1.6
Randolph AFB, TX	AETC	1.8	2.1	2.6	1.4	1.6
Luke AFB, AZ	AETC	1.2	1.6	1.7	2.7	1.5
Vance AFB, OK	AETC	0.7	0.7	6.4	0.0	1.4
Tyndall AFB, FL	AETC	0.2	0.2	1.3	0.4	0.4
Kelly AFB, TX	AFMC	1.1	0.7	9.8	5.1	3.0
Tinker AFB, OK	AFMC	2.5	2.8	0.7	4.9	2.1
Edwards AFB, CA	AFMC	0.6	0.6	1.5	2.8	1.0
Hill AFB, UT	AFMC	0.2	0.0	0.4	1.5	0.4
Eglin AFB, FL	AFMC	0.6	0.0	0.4	0.5	0.3
Patrick AFB, FL	AFSPC	0.4	2.0	2.1	2.5	1.4
McConnell AFB, KS	AMC	3.8	6.1	2.6	4.9	3.6
Dover AFB, DE	AMC	4.0	6.3	2.0	0.8	2.8
McGuire AFB, NJ	AMC	2.0	2.0	4.0	0.8	1.8
Travis AFB, CA	AMC	1.8	3.5	0.8	1.0	1.4
McChord AFB, WA	AMC	0.0	3.0	0.6	0.0	0.7
Elmendorf AFB, AK	PACAF	0.3	0.3	0.0	0.7	0.2

Table 2.9 Odds of damage ratios, based on FY 1994-1997 USAF bird strikes, for Cargo/airlift/transport aircraft and USAF airfields with bird strike rates ≥ 2.00 .

	Aircraft Speed	Howard	Altus	Barksdale	Laughlin	McConnell	Kelly	Dover	Sheppard	Tinker
Small	0-50 KIAS	0.1406	0.0001	0.0599	0.0449	<0.0001	0.1003	0.1553	<0.0001	0.2664
Small	51-100 KIAS	0.0092	<0.0001	0.0039	0.0029	<0.0001	0.0066	0.0102	<0.0001	0.0175
Small	101-150 KIAS	0.0482	<0.0001	0.0205	0.0154	<0.0001	0.0344	0.0532	<0.0001	0.0913
Small	151-200 KIAS	0.0682	<0.0001	0.0291	0.0218	<0.0001	0.0487	0.0754	<0.0001	0.1293
Small	201-250 KIAS	0.1507	0.0001	0.0642	0.0481	0.0001	0.1075	0.1665	<0.0001	0.2856
Small	251-300 KIAS	0.0207	<0.0001	0.0088	0.0066	<0.0001	0.0148	0.0229	<0.0001	0.0393
Small	>300 KIAS	0.2646	0.0002	0.1127	0.0845	0.0001	0.1887	0.2924	0.0001	0.5015
Small-medium	0-50 KIAS	0.2689	0.0002	0.1145	0.0858	0.0001	0.1918	0.2972	0.0001	0.5097
Small-medium	51-100 KIAS	0.0177	<0.0001	0.0075	0.0056	<0.0001	0.0126	0.0195	<0.0001	0.0335
Small-medium	101-150 KIAS	0.0922	0.0001	0.0392	0.0294	<0.0001	0.0657	0.1018	<0.0001	0.1747
Small-medium	151-200 KIAS	0.0682	<0.0001	0.0291	0.0218	<0.0001	0.0487	0.0754	<0.0001	0.1293
Small-medium	201-250 KIAS	0.1507	0.0001	0.0642	0.0481	0.0001	0.1075	0.1665	<0.0001	0.2856
Small-medium	251-300 KIAS	0.0207	<0.0001	0.0088	0.0066	<0.0001	0.0148	0.0229	<0.0001	0.0393
Small-medium	>300 KIAS	0.2646	0.0002	0.1127	0.0845	0.0001	0.1887	0.2924	0.0001	0.5015
Medium	0-50 KIAS	0.3070	0.0002	0.1307	0.0980	0.0001	0.2190	0.3392	0.0001	0.5818
Medium	51-100 KIAS	0.0202	<0.0001	0.0086	0.0064	<0.0001	0.0144	0.0223	<0.0001	0.0382
Medium	101-150 KIAS	0.1052	0.0001	0.0448	0.0336	<0.0001	0.0750	0.1162	<0.0001	0.1994
Medium	151-200 KIAS	0.1490	0.0001	0.0634	0.0476	0.0001	0.1063	0.1647	<0.0001	0.2824
Medium	201-250 KIAS	0.3291	0.0002	0.1401	0.1050	0.0001	0.2348	0.3637	0.0001	0.6238
Medium	251-300 KIAS	0.0453	<0.0001	0.0193	0.0145	<0.0001	0.0323	0.0500	<0.0001	0.0858
Medium	>300 KIAS	0.5778	0.0003	0.2460	0.1844	0.0002	0.4122	0.6385	0.0001	1.0951
Large	0-50 KIAS	0.9685	0.0006	0.4124	0.3091	0.0003	0.6909	1.0702	0.0002	1.8356
Large	51-100 KIAS	0.0636	<0.0001	0.0271	0.0203	<0.0001	0.0454	0.0703	<0.0001	0.1206
Large	101-150 KIAS	0.3319	0.0002	0.1413	0.1059	0.0001	0.2368	0.3668	0.0001	0.6291
Large	151-200 KIAS	0.4701	0.0003	0.2002	0.1501	0.0002	0.3354	0.5195	0.0001	0.8910
Large	201-250 KIAS	1.0384	0.0006	0.4421	0.3314	0.0004	0.7407	1.1474	0.0003	1.9680
Large	251-300 KIAS	0.1429	0.0001	0.0608	0.0456	<0.0001	0.1019	0.1579	<0.0001	0.2708
Large	>300 KIAS	1.8231	0.0011	0.7762	0.5819	0.0006	1.3004	2.0144	0.0004	3.4552

Table 2.10 Odds of damage ratios, based on FY 1994-1997 USAF bird strikes, for Cargo/airlift/transport aircraft and USAF airfields with bird strike rates <2.00 and ≥1.00.

Bird Size	Aircraft Speed	Davis-M	McGuire	Columbus	Randolph	Luke	Dyess	Little Rock	Vance	Beale	Travis	Patrick	Edwards
Small	0-50 KIAS	0.0001	0.0001	<0.0001	0.1299	0.0961	0.0875	0.0001	<0.0001	0.1198	0.0906	0.0478	0.1180
Small	51-100 KIAS	<0.0001	<0.0001	<0.0001	0.0085	0.0063	0.0057	<0.0001	<0.0001	0.0079	0.0060	0.0031	0.0078
Small	101-150 KIAS	<0.0001	<0.0001	<0.0001	0.0445	0.0329	0.0300	<0.0001	<0.0001	0.0411	0.0310	0.0164	0.0404
Small	151-200 KIAS	<0.0001	0.0001	<0.0001	0.0631	0.0467	0.0425	<0.0001	<0.0001	0.0582	0.0440	0.0232	0.0573
Small	201-250 KIAS	0.0001	0.0001	<0.0001	0.1393	0.1030	0.0938	0.0001	<0.0001	0.1285	0.0971	0.0513	0.1265
Small	251-300 KIAS	<0.0001	<0.0001	<0.0001	0.0192	0.0142	0.0129	<0.0001	<0.0001	0.0177	0.0134	0.0071	0.0174
Small	>300 KIAS	0.0001	0.0002	0.0001	0.2445	0.1809	0.1646	0.0001	<0.0001	0.2256	0.1705	0.0900	0.2220
Small-medium	0-50 KIAS	0.0001	0.0002	0.0001	0.2485	0.1839	0.1673	0.0001	<0.0001	0.2293	0.1733	0.0915	0.2257
Small-medium	51-100 KIAS	<0.0001	<0.0001	<0.0001	0.0163	0.0121	0.0110	<0.0001	<0.0001	0.0151	0.0114	0.0060	0.0148
Small-medium	101-150 KIAS	<0.0001	0.0001	<0.0001	0.0852	0.0630	0.0573	<0.0001	<0.0001	0.0786	0.0594	0.0313	0.0773
Small-medium	151-200 KIAS	<0.0001	0.0001	<0.0001	0.0631	0.0467	0.0425	<0.0001	<0.0001	0.0582	0.0440	0.0232	0.0573
Small-medium	201-250 KIAS	0.0001	0.0001	<0.0001	0.1393	0.1030	0.0938	0.0001	<0.0001	0.1285	0.0971	0.0513	0.1265
Small-medium	251-300 KIAS	<0.0001	<0.0001	<0.0001	0.0192	0.0142	0.0129	<0.0001	<0.0001	0.0177	0.0134	0.0071	0.0174
Small-medium	>300 KIAS	0.0001	0.0002	0.0001	0.2445	0.1809	0.1646	0.0001	<0.0001	0.2256	0.1705	0.0900	0.2220
Medium	0-50 KIAS	0.0001	0.0002	0.0001	0.2837	0.2099	0.1910	0.0001	0.0001	0.2617	0.1978	0.1044	0.2576
Medium	51-100 KIAS	<0.0001	<0.0001	<0.0001	0.0186	0.0138	0.0125	<0.0001	<0.0001	0.0172	0.0130	0.0069	0.0169
Medium	101-150 KIAS	<0.0001	0.0001	<0.0001	0.0972	0.0719	0.0655	0.0001	<0.0001	0.0897	0.0678	0.0358	0.0883
Medium	151-200 KIAS	0.0001	0.0001	<0.0001	0.1377	0.1019	0.0927	0.0001	<0.0001	0.1270	0.0960	0.0507	0.1250
Medium	201-250 KIAS	0.0001	0.0003	0.0001	0.3041	0.2250	0.2048	0.0002	0.0001	0.2806	0.2121	0.1119	0.2762
Medium	251-300 KIAS	<0.0001	<0.0001	<0.0001	0.0418	0.0310	0.0282	<0.0001	<0.0001	0.0386	0.0292	0.0154	0.0380
Medium	>300 KIAS	0.0002	0.0005	0.0001	0.5339	0.3951	0.3595	0.0003	0.0001	0.4926	0.3723	0.1965	0.4849
Large	0-50 KIAS	0.0004	0.0008	0.0002	0.8949	0.6622	0.6026	0.0005	0.0002	0.8257	0.6240	0.3294	0.8128
Large	51-100 KIAS	<0.0001	0.0001	<0.0001	0.0588	0.0435	0.0396	<0.0001	<0.0001	0.0542	0.0410	0.0216	0.0534
Large	101-150 KIAS	0.0001	0.0003	0.0001	0.3067	0.2269	0.2065	0.0002	0.0001	0.2830	0.2139	0.1129	0.2785
Large	151-200 KIAS	0.0002	0.0004	0.0001	0.4344	0.3214	0.2925	0.0002	0.0001	0.4008	0.3029	0.1599	0.3945
Large	201-250 KIAS	0.0004	0.0008	0.0003	0.9595	0.7099	0.6461	0.0005	0.0002	0.8852	0.6690	0.3532	0.8714
Large	251-300 KIAS	0.0001	0.0001	<0.0001	0.1320	0.0977	0.0889	0.0001	<0.0001	0.1218	0.0920	0.0486	0.1199
Large	>300 KIAS	0.0007	0.0015	0.0004	1.6846	1.2464	1.1344	0.0009	0.0003	1.5542	1.1746	0.6201	1.5299

Table 2.11 Odds of damage ratios, based on FY 1994-1997 USAF bird strikes, for Cargo/airlift/transport aircraft and USAF airfields with bird strike rates <1.00.

Bird Size	Aircraft Speed	McChord	Seymour-J	Pope	Tyndall	Hill	Holloman	Eglin	Elmendorf	Nellis	Shaw
Small	0-50 KIAS	0.0001	0.1678	0.0001	0.0742	0.0001	0.0001	0.1291	0.4150	0.0001	0.4406
Small	51-100 KIAS	<0.0001	0.0110	<0.0001	0.0049	<0.0001	<0.0001	0.0085	0.0273	<0.0001	0.0289
Small	101-150 KIAS	<0.0001	0.0575	<0.0001	0.0254	<0.0001	<0.0001	0.0442	0.1422	<0.0001	0.1510
Small	151-200 KIAS	<0.0001	0.0814	<0.0001	0.0360	<0.0001	<0.0001	0.0627	0.2014	<0.0001	0.2139
Small	201-250 KIAS	0.0001	0.1799	0.0001	0.0795	0.0001	0.0001	0.1384	0.4449	0.0001	0.4724
Small	251-300 KIAS	<0.0001	0.0247	<0.0001	0.0109	<0.0001	<0.0001	0.0190	0.0612	<0.0001	0.0650
Small	>300 KIAS	0.0001	0.3158	0.0002	0.1397	0.0001	0.0001	0.2430	0.7811	0.0002	0.8293
Small-medium	0-50 KIAS	0.0001	0.3210	0.0002	0.1419	0.0001	0.0001	0.2470	0.7939	0.0002	0.8429
Small-medium	51-100 KIAS	<0.0001	0.0211	<0.0001	0.0093	<0.0001	<0.0001	0.0162	0.0522	<0.0001	0.0554
Small-medium	101-150 KIAS	<0.0001	0.1100	0.0001	0.0486	<0.0001	<0.0001	0.0846	0.2721	0.0001	0.2889
Small-medium	151-200 KIAS	<0.0001	0.0814	<0.0001	0.0360	<0.0001	<0.0001	0.0627	0.2014	<0.0001	0.2139
Small-medium	201-250 KIAS	0.0001	0.1799	0.0001	0.0795	0.0001	0.0001	0.1384	0.4449	0.0001	0.4724
Small-medium	251-300 KIAS	<0.0001	0.0247	<0.0001	0.0109	<0.0001	<0.0001	0.0190	0.0612	<0.0001	0.0650
Small-medium	>300 KIAS	0.0001	0.3158	0.0002	0.1397	0.0001	0.0001	0.2430	0.7811	0.0002	0.8293
Medium	0-50 KIAS	0.0001	0.3664	0.0002	0.1620	0.0001	0.0001	0.2819	0.9062	0.0002	0.9622
Medium	51-100 KIAS	<0.0001	0.0241	<0.0001	0.0106	<0.0001	<0.0001	0.0185	0.0595	<0.0001	0.0632
Medium	101-150 KIAS	<0.0001	0.1256	0.0001	0.0555	0.0001	<0.0001	0.0966	0.3106	0.0001	0.3297
Medium	151-200 KIAS	0.0001	0.1778	0.0001	0.0786	0.0001	0.0001	0.1368	0.4399	0.0001	0.4670
Medium	201-250 KIAS	0.0001	0.3928	0.0002	0.1737	0.0002	0.0001	0.3022	0.9716	0.0002	1.0315
Medium	251-300 KIAS	<0.0001	0.0540	<0.0001	0.0239	<0.0001	<0.0001	0.0416	0.1337	<0.0001	0.1419
Medium	>300 KIAS	0.0002	0.6896	0.0004	0.3050	0.0003	0.0002	0.5306	1.7058	0.0004	1.8111
Large	0-50 KIAS	0.0004	1.1559	0.0006	0.5112	0.0005	0.0004	0.8894	2.8591	0.0006	3.0356
Large	51-100 KIAS	<0.0001	0.0759	<0.0001	0.0336	<0.0001	<0.0001	0.0584	0.1878	<0.0001	0.1994
Large	101-150 KIAS	0.0001	0.3961	0.0002	0.1752	0.0002	0.0001	0.3048	0.9798	0.0002	1.0403
Large	151-200 KIAS	0.0002	0.5611	0.0003	0.2481	0.0002	0.0002	0.4317	1.3878	0.0003	1.4735
Large	201-250 KIAS	0.0004	1.2392	0.0007	0.5481	0.0005	0.0004	0.9535	3.0653	0.0007	3.2545
Large	251-300 KIAS	0.0001	0.1705	0.0001	0.0754	0.0001	0.0001	0.1312	0.4217	0.0001	0.4478
Large	>300 KIAS	0.0007	2.1757	0.0012	0.9622	0.0009	0.0007	1.6741	5.3818	0.0012	5.7139

Table 2.12 Odds of damage ratios, based on FY 1994-1997 USAF bird strikes, for Fighter/attack aircraft and USAF airfields with bird strike rates ≥ 2.00 .

Bird Size	Aircraft Speed	Howard	Altus	Barksdale	Laughlin	McConnell	Kelly	Dover	Sheppard	Tinker
Small	0-50 KIAS	0.1141	0.0001	0.0486	0.0364	<0.0001	0.0814	0.1260	<0.0001	0.2162
Small	51-100 KIAS	0.0075	<0.0001	0.0032	0.0024	<0.0001	0.0053	0.0083	<0.0001	0.0142
Small	101-150 KIAS	0.0391	<0.0001	0.0166	0.0125	<0.0001	0.0279	0.0432	<0.0001	0.0741
Small	151-200 KIAS	0.0554	<0.0001	0.0236	0.0177	<0.0001	0.0395	0.0612	<0.0001	0.1049
Small	201-250 KIAS	0.1223	0.0001	0.0521	0.0390	<0.0001	0.0872	0.1351	<0.0001	0.2318
Small	251-300 KIAS	0.0168	<0.0001	0.0072	0.0054	<0.0001	0.0120	0.0186	<0.0001	0.0319
Small	>300 KIAS	0.2147	0.0001	0.0914	0.0685	0.0001	0.1532	0.2373	0.0001	0.4070
Small-medium	0-50 KIAS	0.2182	0.0001	0.0929	0.0697	0.0001	0.1557	0.2411	0.0001	0.4136
Small-medium	51-100 KIAS	0.0143	<0.0001	0.0061	0.0046	<0.0001	0.0102	0.0158	<0.0001	0.0272
Small-medium	101-150 KIAS	0.0748	<0.0001	0.0318	0.0239	<0.0001	0.0533	0.0826	<0.0001	0.1417
Small-medium	151-200 KIAS	0.1059	0.0001	0.0451	0.0338	<0.0001	0.0756	0.1171	<0.0001	0.2008
Small-medium	201-250 KIAS	0.2340	0.0001	0.0996	0.0747	0.0001	0.1669	0.2585	0.0001	0.4434
Small-medium	251-300 KIAS	0.0322	<0.0001	0.0137	0.0103	<0.0001	0.0230	0.0356	<0.0001	0.0610
Small-medium	>300 KIAS	0.4108	0.0002	0.1749	0.1311	0.0001	0.2930	0.4539	0.0001	0.7785
Medium	0-50 KIAS	0.2491	0.0001	0.1061	0.0795	0.0001	0.1777	0.2753	0.0001	0.4721
Medium	51-100 KIAS	0.0164	<0.0001	0.0070	0.0052	<0.0001	0.0117	0.0181	<0.0001	0.0310
Medium	101-150 KIAS	0.0854	0.0001	0.0363	0.0272	<0.0001	0.0609	0.0943	<0.0001	0.1618
Medium	151-200 KIAS	0.1209	0.0001	0.0515	0.0386	<0.0001	0.0863	0.1336	<0.0001	0.2292
Medium	201-250 KIAS	0.2671	0.0002	0.1137	0.0852	0.0001	0.1905	0.2951	0.0001	0.5062
Medium	251-300 KIAS	0.0367	<0.0001	0.0156	0.0117	<0.0001	0.0262	0.0406	<0.0001	0.0696
Medium	>300 KIAS	0.4689	0.0003	0.1996	0.1497	0.0002	0.3345	0.5181	0.0001	0.8887
Large	0-50 KIAS	0.7860	0.0005	0.3346	0.2509	0.0003	0.5606	0.8685	0.0002	1.4896
Large	51-100 KIAS	0.0516	<0.0001	0.0220	0.0165	<0.0001	0.0368	0.0571	<0.0001	0.0979
Large	101-150 KIAS	0.2694	0.0002	0.1147	0.0860	0.0001	0.1921	0.2976	0.0001	0.5105
Large	151-200 KIAS	0.3815	0.0002	0.1624	0.1218	0.0001	0.2721	0.4216	0.0001	0.7231
Large	201-250 KIAS	0.8426	0.0005	0.3588	0.2689	0.0003	0.6011	0.9311	0.0002	1.5970
Large	251-300 KIAS	0.1159	0.0001	0.0494	0.0370	<0.0001	0.0827	0.1281	<0.0001	0.2197
Large	>300 KIAS	1.4794	0.0009	0.6299	0.4722	0.0005	1.0553	1.6347	0.0004	2.8039

Table 2.13 Odds of damage ratios, based on FY 1994-1997 USAF bird strikes, for Fighter/attack aircraft and USAF airfields with bird strike rates <2.00 and ≥1.00.

Bird Size	Aircraft Speed	Davis-M	McGuire	Columbus	Randolph	Luke	Dyess	Little Rock	Vance	Beale	Travis	Patrick	Edwards
Small	0-50 KIAS	<0.0001	0.0001	<0.0001	0.1054	0.0780	0.0710	0.0001	<0.0001	0.0972	0.0735	0.0388	0.0957
Small	51-100 KIAS	<0.0001	<0.0001	<0.0001	0.0069	0.0051	0.0047	<0.0001	<0.0001	0.0064	0.0048	0.0025	0.0063
Small	101-150 KIAS	<0.0001	<0.0001	<0.0001	0.0361	0.0267	0.0243	<0.0001	<0.0001	0.0333	0.0252	0.0133	0.0328
Small	151-200 KIAS	<0.0001	<0.0001	<0.0001	0.0512	0.0379	0.0345	<0.0001	<0.0001	0.0472	0.0357	0.0188	0.0465
Small	201-250 KIAS	<0.0001	0.0001	<0.0001	0.1130	0.0836	0.0761	0.0001	<0.0001	0.1043	0.0788	0.0416	0.1026
Small	251-300 KIAS	<0.0001	<0.0001	<0.0001	0.0155	0.0115	0.0105	<0.0001	<0.0001	0.0143	0.0108	0.0057	0.0141
Small	>300 KIAS	0.0001	0.0002	0.0001	0.1984	0.1468	0.1336	0.0001	<0.0001	0.1831	0.1383	0.0730	0.1802
Small-medium	0-50 KIAS	0.0001	0.0002	0.0001	0.2017	0.1492	0.1358	0.0001	<0.0001	0.1860	0.1406	0.0742	0.1831
Small-medium	51-100 KIAS	<0.0001	<0.0001	<0.0001	0.0132	0.0098	0.0089	<0.0001	<0.0001	0.0122	0.0092	0.0049	0.0120
Small-medium	101-150 KIAS	<0.0001	0.0001	<0.0001	0.0691	0.0511	0.0465	<0.0001	<0.0001	0.0638	0.0482	0.0254	0.0628
Small-medium	151-200 KIAS	<0.0001	0.0001	<0.0001	0.0979	0.0724	0.0659	0.0001	<0.0001	0.0903	0.0683	0.0360	0.0889
Small-medium	201-250 KIAS	0.0001	0.0002	0.0001	0.2162	0.1600	0.1456	0.0001	<0.0001	0.1995	0.1508	0.0796	0.1963
Small-medium	251-300 KIAS	<0.0001	<0.0001	<0.0001	0.0297	0.0220	0.0200	<0.0001	<0.0001	0.0274	0.0207	0.0109	0.0270
Small-medium	>300 KIAS	0.0002	0.0003	0.0001	0.3796	0.2809	0.2556	0.0002	0.0001	0.3502	0.2647	0.1397	0.3447
Medium	0-50 KIAS	0.0001	0.0002	0.0001	0.2302	0.1703	0.1550	0.0001	<0.0001	0.2124	0.1605	0.0847	0.2091
Medium	51-100 KIAS	<0.0001	<0.0001	<0.0001	0.0151	0.0112	0.0102	<0.0001	<0.0001	0.0140	0.0105	0.0056	0.0137
Medium	101-150 KIAS	<0.0001	0.0001	<0.0001	0.0789	0.0584	0.0531	<0.0001	<0.0001	0.0728	0.0550	0.0290	0.0716
Medium	151-200 KIAS	<0.0001	0.0001	<0.0001	0.1117	0.0827	0.0752	0.0001	<0.0001	0.1031	0.0779	0.0411	0.1015
Medium	201-250 KIAS	0.0001	0.0002	0.0001	0.2468	0.1826	0.1662	0.0001	<0.0001	0.2277	0.1721	0.0908	0.2241
Medium	251-300 KIAS	<0.0001	<0.0001	<0.0001	0.0340	0.0251	0.0229	<0.0001	<0.0001	0.0313	0.0237	0.0125	0.0308
Medium	>300 KIAS	0.0002	0.0004	0.0001	0.4333	0.3206	0.2918	0.0002	0.0001	0.3997	0.3021	0.1595	0.3935
Large	0-50 KIAS	0.0003	0.0006	0.0002	0.7263	0.5374	0.4890	0.0004	0.0001	0.6700	0.5064	0.2673	0.6596
Large	51-100 KIAS	<0.0001	<0.0001	<0.0001	0.0477	0.0353	0.0321	<0.0001	<0.0001	0.0440	0.0333	0.0176	0.0433
Large	101-150 KIAS	0.0001	0.0002	0.0001	0.2489	0.1842	0.1676	0.0001	<0.0001	0.2296	0.1735	0.0916	0.2260
Large	151-200 KIAS	0.0001	0.0003	0.0001	0.3525	0.2608	0.2374	0.0002	0.0001	0.3252	0.2458	0.1298	0.3202
Large	201-250 KIAS	0.0003	0.0007	0.0002	0.7786	0.5761	0.5243	0.0004	0.0001	0.7183	0.5429	0.2866	0.7071
Large	251-300 KIAS	<0.0001	0.0001	<0.0001	0.1071	0.0793	0.0721	0.0001	<0.0001	0.0988	0.0747	0.0394	0.0973
Large	>300 KIAS	0.0006	0.0012	0.0004	1.3670	1.0115	0.9205	0.0007	0.0003	1.2612	0.9532	0.5032	1.2415

Table 2.14 Odds of damage ratios, based on FY 1994-1997 USAF bird strikes, for Fighter/attack aircraft and USAF airfields with bird strike rates <1.00.

Bird Size	Aircraft Speed	McChord	Seymour-J	Pope	Tyndall	Hill	Holloman	Eglin	Elmendorf	Nellis	Shaw
Small	0-50 KIAS	<0.0001	0.1361	0.0001	0.0602	0.0001	<0.0001	0.1048	0.3368	0.0001	0.3575
Small	51-100 KIAS	<0.0001	0.0089	<0.0001	0.0040	<0.0001	<0.0001	0.0069	0.0221	<0.0001	0.0235
Small	101-150 KIAS	<0.0001	0.0467	<0.0001	0.0206	<0.0001	<0.0001	0.0359	0.1154	<0.0001	0.1225
Small	151-200 KIAS	<0.0001	0.0661	<0.0001	0.0292	<0.0001	<0.0001	0.0508	0.1635	<0.0001	0.1735
Small	201-250 KIAS	<0.0001	0.1460	0.0001	0.0646	0.0001	<0.0001	0.1123	0.3610	0.0001	0.3833
Small	251-300 KIAS	<0.0001	0.0201	<0.0001	0.0089	<0.0001	<0.0001	0.0155	0.0497	<0.0001	0.0527
Small	>300 KIAS	0.0001	0.2563	0.0001	0.1133	0.0001	0.0001	0.1972	0.6339	0.0001	0.6730
Small-medium	0-50 KIAS	0.0001	0.2605	0.0001	0.1152	0.0001	0.0001	0.2004	0.6442	0.0001	0.6840
Small-medium	51-100 KIAS	<0.0001	0.0171	<0.0001	0.0076	<0.0001	<0.0001	0.0132	0.0423	<0.0001	0.0449
Small-medium	101-150 KIAS	<0.0001	0.0893	<0.0001	0.0395	<0.0001	<0.0001	0.0687	0.2208	<0.0001	0.2344
Small-medium	151-200 KIAS	<0.0001	0.1264	0.0001	0.0559	0.0001	<0.0001	0.0973	0.3127	0.0001	0.3320
Small-medium	201-250 KIAS	0.0001	0.2792	0.0002	0.1235	0.0001	0.0001	0.2148	0.6907	0.0002	0.7333
Small-medium	251-300 KIAS	<0.0001	0.0384	<0.0001	0.0170	<0.0001	<0.0001	0.0296	0.0950	<0.0001	0.1009
Small-medium	>300 KIAS	0.0002	0.4903	0.0003	0.2168	0.0002	0.0002	0.3772	1.2127	0.0003	1.2875
Medium	0-50 KIAS	0.0001	0.2973	0.0002	0.1315	0.0001	0.0001	0.2288	0.7354	0.0002	0.7808
Medium	51-100 KIAS	<0.0001	0.0195	<0.0001	0.0086	<0.0001	<0.0001	0.0150	0.0483	<0.0001	0.0513
Medium	101-150 KIAS	<0.0001	0.1019	0.0001	0.0451	<0.0001	<0.0001	0.0784	0.2520	0.0001	0.2676
Medium	151-200 KIAS	<0.0001	0.1443	0.0001	0.0638	0.0001	<0.0001	0.1110	0.3570	0.0001	0.3790
Medium	201-250 KIAS	0.0001	0.3187	0.0002	0.1410	0.0001	0.0001	0.2452	0.7884	0.0002	0.8371
Medium	251-300 KIAS	<0.0001	0.0439	<0.0001	0.0194	<0.0001	<0.0001	0.0337	0.1085	<0.0001	0.1152
Medium	>300 KIAS	0.0002	0.5596	0.0003	0.2475	0.0002	0.0002	0.4306	1.3842	0.0003	1.4697
Large	0-50 KIAS	0.0003	0.9380	0.0005	0.4148	0.0004	0.0003	0.7217	2.3202	0.0005	2.4634
Large	51-100 KIAS	<0.0001	0.0616	<0.0001	0.0273	<0.0001	<0.0001	0.0474	0.1524	<0.0001	0.1618
Large	101-150 KIAS	0.0001	0.3215	0.0002	0.1422	0.0001	0.0001	0.2473	0.7951	0.0002	0.8442
Large	151-200 KIAS	0.0001	0.4553	0.0003	0.2014	0.0002	0.0001	0.3503	1.1262	0.0003	1.1957
Large	201-250 KIAS	0.0003	1.0056	0.0006	0.4448	0.0004	0.0003	0.7738	2.4875	0.0006	2.6410
Large	251-300 KIAS	<0.0001	0.1384	0.0001	0.0612	0.0001	<0.0001	0.1065	0.3422	0.0001	0.3634
Large	>300 KIAS	0.0006	1.7656	0.0010	0.7809	0.0007	0.0006	1.3585	4.3673	0.0010	4.6369

Table 2.15 Odds of damage ratios, based on FY 1994-1997 USAF bird strikes, for Trainer aircraft and USAF airfields with bird strike rates ≥ 2.00 .

Bird Size	Aircraft Speed	Howard	Altus	Barksdale	Laughlin	McConnell	Kelly	Dover	Sheppard	Tinker
Small	0-50 KIAS	0.3981	0.0002	0.1695	0.1271	0.0001	0.2840	0.4399	0.0001	0.7545
Small	51-100 KIAS	0.0262	<0.0001	0.0111	0.0083	<0.0001	0.0187	0.0289	<0.0001	0.0496
Small	101-150 KIAS	0.1364	0.0001	0.0581	0.0435	<0.0001	0.0973	0.1508	<0.0001	0.2586
Small	151-200 KIAS	0.1932	0.0001	0.0823	0.0617	0.0001	0.1378	0.2135	<0.0001	0.3662
Small	201-250 KIAS	0.4268	0.0003	0.1817	0.1362	0.0001	0.3045	0.4716	0.0001	0.8089
Small	251-300 KIAS	0.0587	<0.0001	0.0250	0.0187	<0.0001	0.0419	0.0649	<0.0001	0.1113
Small	>300 KIAS	0.7494	0.0004	0.3190	0.2392	0.0003	0.5345	0.8280	0.0002	1.4202
Small-medium	0-50 KIAS	0.7616	0.0005	0.3243	0.2431	0.0003	0.5433	0.8416	0.0002	1.4434
Small-medium	51-100 KIAS	0.0500	<0.0001	0.0213	0.0160	<0.0001	0.0357	0.0553	<0.0001	0.0948
Small-medium	101-150 KIAS	0.2610	0.0002	0.1111	0.0833	0.0001	0.1862	0.2884	0.0001	0.4947
Small-medium	151-200 KIAS	0.3697	0.0002	0.1574	0.1180	0.0001	0.2637	0.4085	0.0001	0.7006
Small-medium	201-250 KIAS	0.8165	0.0005	0.3476	0.2606	0.0003	0.5824	0.9022	0.0002	1.5475
Small-medium	251-300 KIAS	0.1123	0.0001	0.0478	0.0359	<0.0001	0.0801	0.1241	<0.0001	0.2129
Small-medium	>300 KIAS	1.4336	0.0009	0.6104	0.4576	0.0005	1.0226	1.5841	0.0004	2.7170
Medium	0-50 KIAS	0.8694	0.0005	0.3701	0.2775	0.0003	0.6201	0.9606	0.0002	1.6477
Medium	51-100 KIAS	0.0571	<0.0001	0.0243	0.0182	<0.0001	0.0407	0.0631	<0.0001	0.1083
Medium	101-150 KIAS	0.2979	0.0002	0.1268	0.0951	0.0001	0.2125	0.3292	0.0001	0.5647
Medium	151-200 KIAS	0.4220	0.0003	0.1797	0.1347	0.0001	0.3010	0.4663	0.0001	0.7998
Medium	201-250 KIAS	0.9321	0.0006	0.3968	0.2975	0.0003	0.6649	1.0299	0.0002	1.7665
Medium	251-300 KIAS	0.1282	0.0001	0.0546	0.0409	<0.0001	0.0915	0.1417	<0.0001	0.2430
Medium	>300 KIAS	1.6365	0.0010	0.6967	0.5223	0.0006	1.1673	1.8082	0.0004	3.1015
Large	0-50 KIAS	2.7429	0.0016	1.1678	0.8755	0.0010	1.9566	3.0308	0.0007	5.1985
Large	51-100 KIAS	0.1802	0.0001	0.0767	0.0575	0.0001	0.1285	0.1991	<0.0001	0.3415
Large	101-150 KIAS	0.9400	0.0006	0.4002	0.3000	0.0003	0.6705	1.0387	0.0002	1.7815
Large	151-200 KIAS	1.3314	0.0008	0.5669	0.4249	0.0005	0.9497	1.4711	0.0003	2.5233
Large	201-250 KIAS	2.9407	0.0017	1.2520	0.9386	0.0010	2.0976	3.2493	0.0007	5.5733
Large	251-300 KIAS	0.4046	0.0002	0.1723	0.1291	0.0001	0.2886	0.4470	0.0001	0.7668
Large	>300 KIAS	5.1630	0.0031	2.1982	1.6479	0.0018	3.6829	5.7049	0.0013	9.7851

Table 2.16 Odds of damage ratios, based on FY 1994-1997 USAF bird strikes, for Trainer aircraft and USAF airfields with bird strike rates <2.00 and ≥1.00.

Bird Size	Aircraft Speed	Davis-M	McGuire	Columbus	Randolph	Luke	Dyess	Little Rock	Vance	Beale	Travis	Patrick	Edwards
Small	0-50 KIAS	0.0002	0.0003	0.0001	0.3679	0.2722	0.2477	0.0002	0.0001	0.3394	0.2565	0.1354	0.3341
Small	51-100 KIAS	<0.0001	<0.0001	<0.0001	0.0242	0.0179	0.0163	<0.0001	<0.0001	0.0223	0.0169	0.0089	0.0219
Small	101-150 KIAS	0.0001	0.0001	<0.0001	0.1261	0.0933	0.0849	0.0001	<0.0001	0.1163	0.0879	0.0464	0.1145
Small	151-200 KIAS	0.0001	0.0002	<0.0001	0.1786	0.1321	0.1202	0.0001	<0.0001	0.1647	0.1245	0.0657	0.1622
Small	201-250 KIAS	0.0002	0.0003	0.0001	0.3944	0.2918	0.2656	0.0002	0.0001	0.3639	0.2750	0.1452	0.3582
Small	251-300 KIAS	<0.0001	<0.0001	<0.0001	0.0543	0.0401	0.0365	<0.0001	<0.0001	0.0501	0.0378	0.0200	0.0493
Small	>300 KIAS	0.0003	0.0006	0.0002	0.6924	0.5123	0.4663	0.0004	0.0001	0.6388	0.4828	0.2549	0.6288
Small-medium	0-50 KIAS	0.0003	0.0006	0.0002	0.7037	0.5207	0.4739	0.0004	0.0001	0.6493	0.4907	0.2591	0.6391
Small-medium	51-100 KIAS	<0.0001	<0.0001	<0.0001	0.0462	0.0342	0.0311	<0.0001	<0.0001	0.0427	0.0322	0.0170	0.0420
Small-medium	101-150 KIAS	0.0001	0.0002	0.0001	0.2412	0.1784	0.1624	0.0001	<0.0001	0.2225	0.1682	0.0888	0.2190
Small-medium	151-200 KIAS	0.0001	0.0003	0.0001	0.3416	0.2528	0.2300	0.0002	0.0001	0.3152	0.2382	0.1257	0.3102
Small-medium	201-250 KIAS	0.0003	0.0007	0.0002	0.7545	0.5583	0.5081	0.0004	0.0001	0.6961	0.5261	0.2777	0.6852
Small-medium	251-300 KIAS	<0.0001	0.0001	<0.0001	0.1038	0.0768	0.0699	0.0001	<0.0001	0.0958	0.0724	0.0382	0.0943
Small-medium	>300 KIAS	0.0006	0.0012	0.0004	1.3247	0.9801	0.8920	0.0007	0.0003	1.2221	0.9237	0.4876	1.2030
Medium	0-50 KIAS	0.0003	0.0007	0.0002	0.8033	0.5944	0.5409	0.0004	0.0002	0.7411	0.5602	0.2957	0.7296
Medium	51-100 KIAS	<0.0001	<0.0001	<0.0001	0.0528	0.0391	0.0355	<0.0001	<0.0001	0.0487	0.0368	0.0194	0.0479
Medium	101-150 KIAS	0.0001	0.0002	0.0001	0.2753	0.2037	0.1854	0.0001	0.0001	0.2540	0.1920	0.1013	0.2500
Medium	151-200 KIAS	0.0002	0.0003	0.0001	0.3899	0.2885	0.2626	0.0002	0.0001	0.3598	0.2719	0.1435	0.3541
Medium	201-250 KIAS	0.0004	0.0007	0.0002	0.8612	0.6373	0.5800	0.0005	0.0002	0.7946	0.6005	0.3170	0.7822
Medium	251-300 KIAS	<0.0001	0.0001	<0.0001	0.1185	0.0877	0.0798	0.0001	<0.0001	0.1093	0.0826	0.0436	0.1076
Medium	>300 KIAS	0.0006	0.0013	0.0004	1.5121	1.1188	1.0182	0.0008	0.0003	1.3951	1.0544	0.5566	1.3732
Large	0-50 KIAS	0.0011	0.0022	0.0007	2.5345	1.8753	1.7067	0.0013	0.0005	2.3383	1.7673	0.9330	2.3018
Large	51-100 KIAS	0.0001	0.0001	<0.0001	0.1665	0.1232	0.1121	0.0001	<0.0001	0.1536	0.1161	0.0613	0.1512
Large	101-150 KIAS	0.0004	0.0008	0.0002	0.8686	0.6427	0.5849	0.0005	0.0002	0.8013	0.6056	0.3197	0.7888
Large	151-200 KIAS	0.0005	0.0011	0.0003	1.2302	0.9103	0.8284	0.0007	0.0002	1.1350	0.8578	0.4529	1.1173
Large	201-250 KIAS	0.0011	0.0024	0.0007	2.7172	2.0105	1.8298	0.0014	0.0005	2.5069	1.8947	1.0002	2.4677
Large	251-300 KIAS	0.0002	0.0003	0.0001	0.3738	0.2766	0.2517	0.0002	0.0001	0.3449	0.2607	0.1376	0.3395
Large	>300 KIAS	0.0020	0.0041	0.0013	4.7707	3.5299	3.2125	0.0025	0.0009	4.4014	3.3265	1.7561	4.3326

Table 2.17 Odds of damage ratios, based on FY 1994-1997 USAF bird strikes, for Trainer aircraft and USAF airfields with bird strike rates <1.00.

Bird Size	Aircraft Speed	McChord	Seymour-J	Pope	Tyndall	Hill	Holloman	Eglin	Elmendorf	Nellis	Shaw
Small	0-50 KIAS	0.0002	0.4751	0.0003	0.2101	0.0002	0.0002	0.3656	1.1752	0.0003	1.2477
Small	51-100 KIAS	<0.0001	0.0312	<0.0001	0.0138	<0.0001	<0.0001	0.0240	0.0772	<0.0001	0.0820
Small	101-150 KIAS	0.0001	0.1628	0.0001	0.0720	0.0001	0.0001	0.1253	0.4027	0.0001	0.4276
Small	151-200 KIAS	0.0001	0.2306	0.0001	0.1020	0.0001	0.0001	0.1774	0.5704	0.0001	0.6057
Small	201-250 KIAS	0.0002	0.5094	0.0003	0.2253	0.0002	0.0002	0.3919	1.2599	0.0003	1.3377
Small	251-300 KIAS	<0.0001	0.0701	<0.0001	0.0310	<0.0001	<0.0001	0.0539	0.1733	<0.0001	0.1840
Small	>300 KIAS	0.0003	0.8943	0.0005	0.3955	0.0004	0.0003	0.6881	2.2121	0.0005	2.3486
Small-medium	0-50 KIAS	0.0003	0.9089	0.0005	0.4020	0.0004	0.0003	0.6994	2.2483	0.0005	2.3871
Small-medium	51-100 KIAS	<0.0001	0.0597	<0.0001	0.0264	<0.0001	<0.0001	0.0459	0.1477	<0.0001	0.1568
Small-medium	101-150 KIAS	0.0001	0.3115	0.0002	0.1378	0.0001	0.0001	0.2397	0.7705	0.0002	0.8180
Small-medium	151-200 KIAS	0.0001	0.4412	0.0002	0.1951	0.0002	0.0001	0.3395	1.0913	0.0002	1.1587
Small-medium	201-250 KIAS	0.0003	0.9745	0.0005	0.4310	0.0004	0.0003	0.7498	2.4104	0.0005	2.5592
Small-medium	251-300 KIAS	<0.0001	0.1341	0.0001	0.0593	0.0001	<0.0001	0.1032	0.3316	0.0001	0.3521
Small-medium	>300 KIAS	0.0006	1.7109	0.0010	0.7567	0.0007	0.0006	1.3164	4.2320	0.0010	4.4932
Medium	0-50 KIAS	0.0003	1.0376	0.0006	0.4589	0.0004	0.0003	0.7983	2.5664	0.0006	2.7248
Medium	51-100 KIAS	<0.0001	0.0682	<0.0001	0.0301	<0.0001	<0.0001	0.0524	0.1686	<0.0001	0.1790
Medium	101-150 KIAS	0.0001	0.3556	0.0002	0.1573	0.0001	0.0001	0.2736	0.8795	0.0002	0.9338
Medium	151-200 KIAS	0.0002	0.5036	0.0003	0.2227	0.0002	0.0002	0.3875	1.2457	0.0003	1.3226
Medium	201-250 KIAS	0.0004	1.1124	0.0006	0.4920	0.0005	0.0004	0.8559	2.7515	0.0006	2.9213
Medium	251-300 KIAS	<0.0001	0.1530	0.0001	0.0677	0.0001	<0.0001	0.1178	0.3785	0.0001	0.4019
Medium	>300 KIAS	0.0006	1.9530	0.0011	0.8637	0.0008	0.0006	1.5027	4.8308	0.0011	5.1289
Large	0-50 KIAS	0.0011	3.2735	0.0018	1.4477	0.0013	0.0011	2.5187	8.0971	0.0018	8.5969
Large	51-100 KIAS	0.0001	0.2151	0.0001	0.0951	0.0001	0.0001	0.1655	0.5320	0.0001	0.5648
Large	101-150 KIAS	0.0004	1.1218	0.0006	0.4961	0.0005	0.0004	0.8632	2.7749	0.0006	2.9461
Large	151-200 KIAS	0.0005	1.5890	0.0009	0.7027	0.0007	0.0005	1.2226	3.9303	0.0009	4.1729
Large	201-250 KIAS	0.0011	3.5095	0.0019	1.5521	0.0014	0.0011	2.7003	8.6809	0.0019	9.2167
Large	251-300 KIAS	0.0002	0.4828	0.0003	0.2135	0.0002	0.0002	0.3715	1.1943	0.0003	1.2680
Large	>300 KIAS	0.0020	6.1617	0.0034	2.7251	0.0025	0.0020	4.7410	15.2412	0.0034	16.1819

Table 2.18 Odds of damage ratios, based on FY 1994-1997 USAF bird strikes, for Bomber aircraft and USAF airfields with bird strike rates ≥ 2.00 .

Bird Size	Aircraft Speed	Howard	Altus	Barksdale	Laughlin	McConnell	Kelly	Dover	Sheppard	Tinker
Small	0-50 KIAS	0.3387	0.0002	0.1442	0.1081	0.0001	0.2416	0.3743	0.0001	0.6420
Small	51-100 KIAS	0.0223	<0.0001	0.0095	0.0071	<0.0001	0.0159	0.0246	<0.0001	0.0422
Small	101-150 KIAS	0.1161	0.0001	0.0494	0.0371	<0.0001	0.0828	0.1283	<0.0001	0.2200
Small	151-200 KIAS	0.1644	0.0001	0.0700	0.0525	0.0001	0.1173	0.1817	<0.0001	0.3116
Small	201-250 KIAS	0.3632	0.0002	0.1546	0.1159	0.0001	0.2591	0.4013	0.0001	0.6883
Small	251-300 KIAS	0.0500	<0.0001	0.0213	0.0159	<0.0001	0.0356	0.0552	<0.0001	0.0947
Small	>300 KIAS	0.6376	0.0004	0.2715	0.2035	0.0002	0.4548	0.7045	0.0002	1.2084
Small-medium	0-50 KIAS	0.6481	0.0004	0.2759	0.2068	0.0002	0.4623	0.7161	0.0002	1.2282
Small-medium	51-100 KIAS	0.0426	<0.0001	0.0181	0.0136	<0.0001	0.0304	0.0470	<0.0001	0.0807
Small-medium	101-150 KIAS	0.2221	0.0001	0.0946	0.0709	0.0001	0.1584	0.2454	0.0001	0.4209
Small-medium	151-200 KIAS	0.3146	0.0002	0.1339	0.1004	0.0001	0.2244	0.3476	0.0001	0.5962
Small-medium	201-250 KIAS	0.6948	0.0004	0.2958	0.2218	0.0002	0.4956	0.7677	0.0002	1.3168
Small-medium	251-300 KIAS	0.0956	0.0001	0.0407	0.0305	<0.0001	0.0682	0.1056	<0.0001	0.1812
Small-medium	>300 KIAS	1.2198	0.0007	0.5193	0.3893	0.0004	0.8701	1.3478	0.0003	2.3118
Medium	0-50 KIAS	0.7397	0.0004	0.3150	0.2361	0.0003	0.5277	0.8174	0.0002	1.4020
Medium	51-100 KIAS	0.0486	<0.0001	0.0207	0.0155	<0.0001	0.0347	0.0537	<0.0001	0.0921
Medium	101-150 KIAS	0.2535	0.0002	0.1079	0.0809	0.0001	0.1808	0.2801	0.0001	0.4805
Medium	151-200 KIAS	0.3591	0.0002	0.1529	0.1146	0.0001	0.2561	0.3968	0.0001	0.6805
Medium	201-250 KIAS	0.7931	0.0005	0.3377	0.2531	0.0003	0.5657	0.8763	0.0002	1.5031
Medium	251-300 KIAS	0.1091	0.0001	0.0465	0.0348	<0.0001	0.0778	0.1206	<0.0001	0.2068
Medium	>300 KIAS	1.3924	0.0008	0.5928	0.4444	0.0005	0.9932	1.5386	0.0003	2.6390
Large	0-50 KIAS	2.3339	0.0014	0.9937	0.7449	0.0008	1.6648	2.5789	0.0006	4.4233
Large	51-100 KIAS	0.1533	0.0001	0.0653	0.0489	0.0001	0.1094	0.1694	<0.0001	0.2906
Large	101-150 KIAS	0.7998	0.0005	0.3405	0.2553	0.0003	0.5705	0.8838	0.0002	1.5159
Large	151-200 KIAS	1.1329	0.0007	0.4823	0.3616	0.0004	0.8081	1.2518	0.0003	2.1471
Large	201-250 KIAS	2.5022	0.0015	1.0653	0.7986	0.0009	1.7848	2.7648	0.0006	4.7422
Large	251-300 KIAS	0.3443	0.0002	0.1466	0.1099	0.0001	0.2456	0.3804	0.0001	0.6524
Large	>300 KIAS	4.3931	0.0026	1.8704	1.4021	0.0015	3.1337	4.8542	0.0011	8.3260

Table 2.19 Odds of damage ratios, based on FY 1994-1997 USAF bird strikes, for Bomber aircraft and USAF airfields with bird strike rates <2.00 and ≥1.00.

Bird Size	Aircraft Speed	Davis-M	McGuire	Columbus	Randolph	Luke	Dyess	Little Rock	Vance	Beale	Travis	Patrick	Edwards
Small	0-50 KIAS	0.0001	0.0003	0.0001	0.3130	0.2316	0.2108	0.0002	0.0001	0.2888	0.2183	0.1152	0.2843
Small	51-100 KIAS	<0.0001	<0.0001	<0.0001	0.0206	0.0152	0.0138	<0.0001	<0.0001	0.0190	0.0143	0.0076	0.0187
Small	101-150 KIAS	<0.0001	0.0001	<0.0001	0.1073	0.0794	0.0722	0.0001	<0.0001	0.0990	0.0748	0.0395	0.0974
Small	151-200 KIAS	0.0001	0.0001	<0.0001	0.1519	0.1124	0.1023	0.0001	<0.0001	0.1402	0.1059	0.0559	0.1380
Small	201-250 KIAS	0.0001	0.0003	0.0001	0.3356	0.2483	0.2260	0.0002	0.0001	0.3096	0.2340	0.1235	0.3048
Small	251-300 KIAS	<0.0001	<0.0001	<0.0001	0.0462	0.0342	0.0311	<0.0001	<0.0001	0.0426	0.0322	0.0170	0.0419
Small	>300 KIAS	0.0002	0.0005	0.0002	0.5892	0.4359	0.3967	0.0003	0.0001	0.5436	0.4108	0.2169	0.5351
Small-medium	0-50 KIAS	0.0002	0.0005	0.0002	0.5988	0.4431	0.4032	0.0003	0.0001	0.5525	0.4175	0.2204	0.5438
Small-medium	51-100 KIAS	<0.0001	<0.0001	<0.0001	0.0393	0.0291	0.0265	<0.0001	<0.0001	0.0363	0.0274	0.0145	0.0357
Small-medium	101-150 KIAS	0.0001	0.0002	0.0001	0.2052	0.1518	0.1382	0.0001	<0.0001	0.1893	0.1431	0.0755	0.1864
Small-medium	151-200 KIAS	0.0001	0.0003	0.0001	0.2907	0.2151	0.1957	0.0002	0.0001	0.2682	0.2027	0.1070	0.2640
Small-medium	201-250 KIAS	0.0003	0.0006	0.0002	0.6420	0.4750	0.4323	0.0003	0.0001	0.5923	0.4476	0.2363	0.5830
Small-medium	251-300 KIAS	<0.0001	0.0001	<0.0001	0.0883	0.0654	0.0595	<0.0001	<0.0001	0.0815	0.0616	0.0325	0.0802
Small-medium	>300 KIAS	0.0005	0.0010	0.0003	1.1271	0.8340	0.7590	0.0006	0.0002	1.0399	0.7859	0.4149	1.0236
Medium	0-50 KIAS	0.0003	0.0006	0.0002	0.6835	0.5058	0.4603	0.0004	0.0001	0.6306	0.4766	0.2516	0.6208
Medium	51-100 KIAS	<0.0001	<0.0001	<0.0001	0.0449	0.0332	0.0302	<0.0001	<0.0001	0.0414	0.0313	0.0165	0.0408
Medium	101-150 KIAS	0.0001	0.0002	0.0001	0.2342	0.1733	0.1577	0.0001	<0.0001	0.2161	0.1633	0.0862	0.2127
Medium	151-200 KIAS	0.0001	0.0003	0.0001	0.3318	0.2455	0.2234	0.0002	0.0001	0.3061	0.2314	0.1221	0.3013
Medium	201-250 KIAS	0.0003	0.0006	0.0002	0.7328	0.5422	0.4935	0.0004	0.0001	0.6761	0.5110	0.2698	0.6655
Medium	251-300 KIAS	<0.0001	0.0001	<0.0001	0.1008	0.0746	0.0679	0.0001	<0.0001	0.0930	0.0703	0.0371	0.0916
Medium	>300 KIAS	0.0005	0.0011	0.0003	1.2866	0.9520	0.8664	0.0007	0.0002	1.1870	0.8971	0.4736	1.1685
Large	0-50 KIAS	0.0009	0.0019	0.0006	2.1566	1.5957	1.4522	0.0011	0.0004	1.9896	1.5037	0.7938	1.9585
Large	51-100 KIAS	0.0001	0.0001	<0.0001	0.1417	0.1048	0.0954	0.0001	<0.0001	0.1307	0.0988	0.0522	0.1287
Large	101-150 KIAS	0.0003	0.0006	0.0002	0.7391	0.5468	0.4977	0.0004	0.0001	0.6818	0.5153	0.2721	0.6712
Large	151-200 KIAS	0.0004	0.0009	0.0003	1.0468	0.7745	0.7049	0.0006	0.0002	0.9658	0.7299	0.3853	0.9507
Large	201-250 KIAS	0.0010	0.0020	0.0006	2.3120	1.7107	1.5569	0.0012	0.0004	2.1331	1.6122	0.8511	2.0997
Large	251-300 KIAS	0.0001	0.0003	0.0001	0.3181	0.2354	0.2142	0.0002	0.0001	0.2935	0.2218	0.1171	0.2889
Large	>300 KIAS	0.0017	0.0035	0.0011	4.0593	3.0035	2.7335	0.0021	0.0008	3.7451	2.8305	1.4943	3.6865

Table 2.20 Odds of damage ratios, based on FY 1994-1997 USAF bird strikes, for Bomber aircraft and USAF airfields with bird strike rates <1.00.

Bird Size	Aircraft Speed	McChord	Seymour-J	Pope	Tyndall	Hill	Holloman	Eglin	Elmendorf	Nellis	Shaw
Small	0-50 KIAS	0.0001	0.4043	0.0002	0.1788	0.0002	0.0001	0.3111	1.0000	0.0002	1.0617
Small	51-100 KIAS	<0.0001	0.0266	<0.0001	0.0117	<0.0001	<0.0001	0.0204	0.0657	<0.0001	0.0698
Small	101-150 KIAS	<0.0001	0.1385	0.0001	0.0613	0.0001	<0.0001	0.1066	0.3427	0.0001	0.3638
Small	151-200 KIAS	0.0001	0.1962	0.0001	0.0868	0.0001	0.0001	0.1510	0.4854	0.0001	0.5153
Small	201-250 KIAS	0.0001	0.4334	0.0002	0.1917	0.0002	0.0001	0.3335	1.0721	0.0002	1.1382
Small	251-300 KIAS	<0.0001	0.0596	<0.0001	0.0264	<0.0001	<0.0001	0.0459	0.1475	<0.0001	0.1566
Small	>300 KIAS	0.0002	0.7610	0.0004	0.3365	0.0003	0.0002	0.5855	1.8822	0.0004	1.9984
Small-medium	0-50 KIAS	0.0002	0.7734	0.0004	0.3420	0.0003	0.0002	0.5951	1.9130	0.0004	2.0311
Small-medium	51-100 KIAS	<0.0001	0.0508	<0.0001	0.0225	<0.0001	<0.0001	0.0391	0.1257	<0.0001	0.1334
Small-medium	101-150 KIAS	0.0001	0.2650	0.0001	0.1172	0.0001	0.0001	0.2039	0.6556	0.0001	0.6961
Small-medium	151-200 KIAS	0.0001	0.3754	0.0002	0.1660	0.0002	0.0001	0.2888	0.9286	0.0002	0.9859
Small-medium	201-250 KIAS	0.0003	0.8292	0.0005	0.3667	0.0003	0.0003	0.6380	2.0510	0.0005	2.1776
Small-medium	251-300 KIAS	<0.0001	0.1141	0.0001	0.0505	<0.0001	<0.0001	0.0878	0.2822	0.0001	0.2996
Small-medium	>300 KIAS	0.0005	1.4558	0.0008	0.6438	0.0006	0.0005	1.1201	3.6009	0.0008	3.8232
Medium	0-50 KIAS	0.0003	0.8828	0.0005	0.3904	0.0004	0.0003	0.6793	2.1837	0.0005	2.3185
Medium	51-100 KIAS	<0.0001	0.0580	<0.0001	0.0257	<0.0001	<0.0001	0.0446	0.1435	<0.0001	0.1523
Medium	101-150 KIAS	0.0001	0.3025	0.0002	0.1338	0.0001	0.0001	0.2328	0.7484	0.0002	0.7946
Medium	151-200 KIAS	0.0001	0.4285	0.0002	0.1895	0.0002	0.0001	0.3297	1.0600	0.0002	1.1254
Medium	201-250 KIAS	0.0003	0.9465	0.0005	0.4186	0.0004	0.0003	0.7283	2.3412	0.0005	2.4857
Medium	251-300 KIAS	<0.0001	0.1302	0.0001	0.0576	0.0001	<0.0001	0.1002	0.3221	0.0001	0.3420
Medium	>300 KIAS	0.0005	1.6618	0.0009	0.7349	0.0007	0.0005	1.2786	4.1104	0.0009	4.3641
Large	0-50 KIAS	0.0009	2.7854	0.0015	1.2319	0.0011	0.0009	2.1431	6.8897	0.0015	7.3149
Large	51-100 KIAS	0.0001	0.1830	0.0001	0.0809	0.0001	0.0001	0.1408	0.4527	0.0001	0.4806
Large	101-150 KIAS	0.0003	0.9545	0.0005	0.4222	0.0004	0.0003	0.7344	2.3611	0.0005	2.5068
Large	151-200 KIAS	0.0004	1.3520	0.0008	0.5979	0.0006	0.0004	1.0403	3.3443	0.0008	3.5507
Large	201-250 KIAS	0.0010	2.9862	0.0017	1.3207	0.0012	0.0010	2.2976	7.3864	0.0017	7.8423
Large	251-300 KIAS	0.0001	0.4108	0.0002	0.1817	0.0002	0.0001	0.3161	1.0162	0.0002	1.0789
Large	>300 KIAS	0.0017	5.2429	0.0029	2.3187	0.0021	0.0017	4.0340	12.9685	0.0029	13.7689

Table 2.21 Odds of damage ratios, based on FY 1994-1997 USAF bird strikes, for Reconnaissance aircraft and USAF airfields with bird strike rates ≥ 2.00 .

Bird Size	Aircraft Speed	Howard	Altus	Barksdale	Laughlin	McConnell	Kelly	Dover	Sheppard	Tinker
Small	0-50 KIAS	0.0774	<0.0001	0.0329	0.0247	<0.0001	0.0552	0.0855	<0.0001	0.1466
Small	51-100 KIAS	0.0051	<0.0001	0.0022	0.0016	<0.0001	0.0036	0.0056	<0.0001	0.0096
Small	101-150 KIAS	0.0265	<0.0001	0.0113	0.0085	<0.0001	0.0189	0.0293	<0.0001	0.0503
Small	151-200 KIAS	0.0376	<0.0001	0.0160	0.0120	<0.0001	0.0268	0.0415	<0.0001	0.0712
Small	201-250 KIAS	0.0830	<0.0001	0.0353	0.0265	<0.0001	0.0592	0.0917	<0.0001	0.1572
Small	251-300 KIAS	0.0114	<0.0001	0.0049	0.0036	<0.0001	0.0081	0.0126	<0.0001	0.0216
Small	>300 KIAS	0.1456	0.0001	0.0620	0.0465	0.0001	0.1039	0.1609	<0.0001	0.2760
Small-medium	0-50 KIAS	0.1480	0.0001	0.0630	0.0472	0.0001	0.1056	0.1636	<0.0001	0.2805
Small-medium	51-100 KIAS	0.0097	<0.0001	0.0041	0.0031	<0.0001	0.0069	0.0107	<0.0001	0.0184
Small-medium	101-150 KIAS	0.0507	<0.0001	0.0216	0.0162	<0.0001	0.0362	0.0561	<0.0001	0.0961
Small-medium	151-200 KIAS	0.0718	<0.0001	0.0306	0.0229	<0.0001	0.0513	0.0794	<0.0001	0.1362
Small-medium	201-250 KIAS	0.1587	0.0001	0.0676	0.0507	0.0001	0.1132	0.1753	<0.0001	0.3008
Small-medium	251-300 KIAS	0.0218	<0.0001	0.0093	0.0070	<0.0001	0.0156	0.0241	<0.0001	0.0414
Small-medium	>300 KIAS	0.2786	0.0002	0.1186	0.0889	0.0001	0.1987	0.3079	0.0001	0.5280
Medium	0-50 KIAS	0.1690	0.0001	0.0719	0.0539	0.0001	0.1205	0.1867	<0.0001	0.3202
Medium	51-100 KIAS	0.0111	<0.0001	0.0047	0.0035	<0.0001	0.0079	0.0123	<0.0001	0.0210
Medium	101-150 KIAS	0.0579	<0.0001	0.0247	0.0185	<0.0001	0.0413	0.0640	<0.0001	0.1097
Medium	151-200 KIAS	0.0820	<0.0001	0.0349	0.0262	<0.0001	0.0585	0.0906	<0.0001	0.1554
Medium	201-250 KIAS	0.1811	0.0001	0.0771	0.0578	0.0001	0.1292	0.2002	<0.0001	0.3433
Medium	251-300 KIAS	0.0249	<0.0001	0.0106	0.0080	<0.0001	0.0178	0.0275	<0.0001	0.0472
Medium	>300 KIAS	0.3180	0.0002	0.1354	0.1015	0.0001	0.2269	0.3514	0.0001	0.6028
Large	0-50 KIAS	0.5331	0.0003	0.2270	0.1701	0.0002	0.3803	0.5890	0.0001	1.0103
Large	51-100 KIAS	0.0350	<0.0001	0.0149	0.0112	<0.0001	0.0250	0.0387	<0.0001	0.0664
Large	101-150 KIAS	0.1827	0.0001	0.0778	0.0583	0.0001	0.1303	0.2019	<0.0001	0.3462
Large	151-200 KIAS	0.2588	0.0002	0.1102	0.0826	0.0001	0.1846	0.2859	0.0001	0.4904
Large	201-250 KIAS	0.5715	0.0003	0.2433	0.1824	0.0002	0.4077	0.6315	0.0001	1.0832
Large	251-300 KIAS	0.0786	<0.0001	0.0335	0.0251	<0.0001	0.0561	0.0869	<0.0001	0.1490
Large	>300 KIAS	1.0034	0.0006	0.4272	0.3203	0.0004	0.7158	1.1087	0.0002	1.9017

Table 2.22 Odds of damage ratios, based on FY 1994-1997 USAF bird strikes, for Reconnaissance aircraft and USAF airfields with bird strike rates <2.00 and ≥1.00.

Bird Size	Aircraft Speed	Davis-M	McGuire	Columbus	Randolph	Luke	Dyess	Little Rock	Vance	Beale	Travis	Patrick	Edwards
Small	0-50 KIAS	<0.0001	0.0001	<0.0001	0.0715	0.0529	0.0481	<0.0001	<0.0001	0.0660	0.0499	0.0263	0.0649
Small	51-100 KIAS	<0.0001	<0.0001	<0.0001	0.0047	0.0035	0.0032	<0.0001	<0.0001	0.0043	0.0033	0.0017	0.0043
Small	101-150 KIAS	<0.0001	<0.0001	<0.0001	0.0245	0.0181	0.0165	<0.0001	<0.0001	0.0226	0.0171	0.0090	0.0223
Small	151-200 KIAS	<0.0001	<0.0001	<0.0001	0.0347	0.0257	0.0234	<0.0001	<0.0001	0.0320	0.0242	0.0128	0.0315
Small	201-250 KIAS	<0.0001	0.0001	<0.0001	0.0766	0.0567	0.0516	<0.0001	<0.0001	0.0707	0.0534	0.0282	0.0696
Small	251-300 KIAS	<0.0001	<0.0001	<0.0001	0.0105	0.0078	0.0071	<0.0001	<0.0001	0.0097	0.0074	0.0039	0.0096
Small	>300 KIAS	0.0001	0.0001	<0.0001	0.1346	0.0996	0.0906	0.0001	<0.0001	0.1242	0.0938	0.0495	0.1222
Small-medium	0-50 KIAS	0.0001	0.0001	<0.0001	0.1368	0.1012	0.0921	0.0001	<0.0001	0.1262	0.0954	0.0503	0.1242
Small-medium	51-100 KIAS	<0.0001	<0.0001	<0.0001	0.0090	0.0066	0.0061	<0.0001	<0.0001	0.0083	0.0063	0.0033	0.0082
Small-medium	101-150 KIAS	<0.0001	<0.0001	<0.0001	0.0469	0.0347	0.0316	<0.0001	<0.0001	0.0432	0.0327	0.0173	0.0426
Small-medium	151-200 KIAS	<0.0001	0.0001	<0.0001	0.0664	0.0491	0.0447	<0.0001	<0.0001	0.0613	0.0463	0.0244	0.0603
Small-medium	201-250 KIAS	0.0001	0.0001	<0.0001	0.1466	0.1085	0.0987	0.0001	<0.0001	0.1353	0.1022	0.0540	0.1332
Small-medium	251-300 KIAS	<0.0001	<0.0001	<0.0001	0.0202	0.0149	0.0136	<0.0001	<0.0001	0.0186	0.0141	0.0074	0.0183
Small-medium	>300 KIAS	0.0001	0.0002	0.0001	0.2574	0.1905	0.1734	0.0001	<0.0001	0.2375	0.1795	0.0948	0.2338
Medium	0-50 KIAS	0.0001	0.0001	<0.0001	0.1561	0.1155	0.1051	0.0001	<0.0001	0.1440	0.1089	0.0575	0.1418
Medium	51-100 KIAS	<0.0001	<0.0001	<0.0001	0.0103	0.0076	0.0069	<0.0001	<0.0001	0.0095	0.0072	0.0038	0.0093
Medium	101-150 KIAS	<0.0001	<0.0001	<0.0001	0.0535	0.0396	0.0360	<0.0001	<0.0001	0.0494	0.0373	0.0197	0.0486
Medium	151-200 KIAS	<0.0001	0.0001	<0.0001	0.0758	0.0561	0.0510	<0.0001	<0.0001	0.0699	0.0528	0.0279	0.0688
Medium	201-250 KIAS	0.0001	0.0001	<0.0001	0.1674	0.1239	0.1127	0.0001	<0.0001	0.1544	0.1167	0.0616	0.1520
Medium	251-300 KIAS	<0.0001	<0.0001	<0.0001	0.0230	0.0170	0.0155	<0.0001	<0.0001	0.0212	0.0161	0.0085	0.0209
Medium	>300 KIAS	0.0001	0.0003	0.0001	0.2939	0.2174	0.1979	0.0002	0.0001	0.2711	0.2049	0.1082	0.2669
Large	0-50 KIAS	0.0002	0.0004	0.0001	0.4926	0.3645	0.3317	0.0003	0.0001	0.4545	0.3435	0.1813	0.4473
Large	51-100 KIAS	<0.0001	<0.0001	<0.0001	0.0324	0.0239	0.0218	<0.0001	<0.0001	0.0299	0.0226	0.0119	0.0294
Large	101-150 KIAS	0.0001	0.0001	<0.0001	0.1688	0.1249	0.1137	0.0001	<0.0001	0.1557	0.1177	0.0621	0.1533
Large	151-200 KIAS	0.0001	0.0002	0.0001	0.2391	0.1769	0.1610	0.0001	<0.0001	0.2206	0.1667	0.0880	0.2171
Large	201-250 KIAS	0.0002	0.0005	0.0001	0.5281	0.3907	0.3556	0.0003	0.0001	0.4872	0.3682	0.1944	0.4796
Large	251-300 KIAS	<0.0001	0.0001	<0.0001	0.0727	0.0538	0.0489	<0.0001	<0.0001	0.0670	0.0507	0.0267	0.0660
Large	>300 KIAS	0.0004	0.0008	0.0002	0.9272	0.6860	0.6244	0.0005	0.0002	0.8554	0.6465	0.3413	0.8420

Table 2.23 Odds of damage ratios, based on FY 1994-1997 USAF bird strikes, for Reconnaissance aircraft and USAF airfields with bird strike rates <1.00.

Bird Size	Aircraft Speed	McChord	Seymour-J	Pope	Tyndall	Hill	Holloman	Eglin	Elmendorf	Nellis	Shaw
Small	0-50 KIAS	<0.0001	0.0923	0.0001	0.0408	<0.0001	<0.0001	0.0710	0.2284	0.0001	0.2425
Small	51-100 KIAS	<0.0001	0.0061	<0.0001	0.0027	<0.0001	<0.0001	0.0047	0.0150	<0.0001	0.0159
Small	101-150 KIAS	<0.0001	0.0316	<0.0001	0.0140	<0.0001	<0.0001	0.0243	0.0783	<0.0001	0.0831
Small	151-200 KIAS	<0.0001	0.0448	<0.0001	0.0198	<0.0001	<0.0001	0.0345	0.1109	<0.0001	0.1177
Small	201-250 KIAS	<0.0001	0.0990	0.0001	0.0438	<0.0001	<0.0001	0.0762	0.2449	0.0001	0.2600
Small	251-300 KIAS	<0.0001	0.0136	<0.0001	0.0060	<0.0001	<0.0001	0.0105	0.0337	<0.0001	0.0358
Small	>300 KIAS	0.0001	0.1738	0.0001	0.0769	0.0001	0.0001	0.1337	0.4299	0.0001	0.4565
Small-medium	0-50 KIAS	0.0001	0.1767	0.0001	0.0781	0.0001	0.0001	0.1359	0.4370	0.0001	0.4639
Small-medium	51-100 KIAS	<0.0001	0.0116	<0.0001	0.0051	<0.0001	<0.0001	0.0089	0.0287	<0.0001	0.0305
Small-medium	101-150 KIAS	<0.0001	0.0605	<0.0001	0.0268	<0.0001	<0.0001	0.0466	0.1497	<0.0001	0.1590
Small-medium	151-200 KIAS	<0.0001	0.0857	<0.0001	0.0379	<0.0001	<0.0001	0.0660	0.2121	<0.0001	0.2252
Small-medium	201-250 KIAS	0.0001	0.1894	0.0001	0.0838	0.0001	0.0001	0.1457	0.4685	0.0001	0.4974
Small-medium	251-300 KIAS	<0.0001	0.0261	<0.0001	0.0115	<0.0001	<0.0001	0.0200	0.0645	<0.0001	0.0684
Small-medium	>300 KIAS	0.0001	0.3325	0.0002	0.1471	0.0001	0.0001	0.2558	0.8225	0.0002	0.8732
Medium	0-50 KIAS	0.0001	0.2016	0.0001	0.0892	0.0001	0.0001	0.1552	0.4988	0.0001	0.5296
Medium	51-100 KIAS	<0.0001	0.0132	<0.0001	0.0059	<0.0001	<0.0001	0.0102	0.0328	<0.0001	0.0348
Medium	101-150 KIAS	<0.0001	0.0691	<0.0001	0.0306	<0.0001	<0.0001	0.0532	0.1709	<0.0001	0.1815
Medium	151-200 KIAS	<0.0001	0.0979	0.0001	0.0433	<0.0001	<0.0001	0.0753	0.2421	0.0001	0.2571
Medium	201-250 KIAS	0.0001	0.2162	0.0001	0.0956	0.0001	0.0001	0.1663	0.5347	0.0001	0.5678
Medium	251-300 KIAS	<0.0001	0.0297	<0.0001	0.0132	<0.0001	<0.0001	0.0229	0.0736	<0.0001	0.0781
Medium	>300 KIAS	0.0001	0.3796	0.0002	0.1679	0.0002	0.0001	0.2920	0.9389	0.0002	0.9968
Large	0-50 KIAS	0.0002	0.6362	0.0004	0.2814	0.0003	0.0002	0.4895	1.5737	0.0004	1.6708
Large	51-100 KIAS	<0.0001	0.0418	<0.0001	0.0185	<0.0001	<0.0001	0.0322	0.1034	<0.0001	0.1098
Large	101-150 KIAS	0.0001	0.2180	0.0001	0.0964	0.0001	0.0001	0.1678	0.5393	0.0001	0.5726
Large	151-200 KIAS	0.0001	0.3088	0.0002	0.1366	0.0001	0.0001	0.2376	0.7639	0.0002	0.8110
Large	201-250 KIAS	0.0002	0.6821	0.0004	0.3017	0.0003	0.0002	0.5248	1.6871	0.0004	1.7913
Large	251-300 KIAS	<0.0001	0.0938	0.0001	0.0415	<0.0001	<0.0001	0.0722	0.2321	0.0001	0.2464
Large	>300 KIAS	0.0004	1.1975	0.0007	0.5296	0.0005	0.0004	0.9214	2.9621	0.0007	3.1449

Table 2.24 The odds of damage, at different aircraft speeds, resulting from bird strikes during airfield operations involving bomber aircraft and “medium” birds at Barksdale AFB, LA.

Speed	Odds of Damage^a
>300 KIAS	0.5928
201-250 KIAS	0.3377
0-50 KIAS	0.3150
151-200 KIAS	0.1529
101-150 KIAS	0.1079
251-300 KIAS	0.0465
51-100 KIAS	0.0207

^a The odds of damage are based on FY 1994-1997 data on USAF bird strikes.

Table 2.25 The odds of damage resulting from bird strikes, involving different sized birds, during airfield operations involving trainer aircraft at 0-50 KIAS at Randolph AFB, TX.

Bird Size	Odds of Damage^a
Small	0.3679
Small-medium	0.7037
Medium	0.8033
Large	2.5345

^a The odds of damage are based on FY 1994-1997 data on USAF bird strikes.

Table 2.26 The odds of damage resulting from bird strikes during airfield operations involving different aircraft at >300 KIAS and “large” birds at Shaw AFB, SC.

Aircraft Group	Odds of Damage^a
Trainer	16.1819
Bomber	13.7689
Cargo/airlift/transport	5.7139
Fighter/attack	4.6369
Reconnaissance	3.1449

^a The odds of damage are based on FY 1994-1997 data on USAF bird strikes.

Table 2.27 The odds of damage resulting from bird strikes during airfield operations involving fighter aircraft at 151-200 KIAS and “medium” birds at different USAF airfields.

Base	Odds of Damage^a
Shaw AFB, SC	0.3790
Elmendorf AFB, AK	0.3570
Tinker AFB, OK	0.2292
Seymour-Johnson AFB, NC	0.1443
Dover AFB, DE	0.1336
Howard AFB, Panama	0.1209
Randolph AFB, TX	0.1117
Eglin AFB, FL	0.1110
Beale AFB, CA	0.1031
Edwards AFB, CA	0.1015
Kelly AFB, TX	0.0863
Luke AFB, AZ	0.0827
Travis AFB, CA	0.0779
Dyess AFB, TX	0.0752
Tyndall AFB, FL	0.0638
Barksdale AFB, LA	0.0515
Patrick AFB, FL	0.0411
Laughlin AFB, TX	0.0386
Altus AFB, OK	0.0001
Hill AFB, UT	0.0001
Little Rock AFB, AR	0.0001
McGuire AFB, NJ	0.0001
Nellis AFB, NV	0.0001
Pope AFB, NC	0.0001
Columbus AFB, MS	<0.0001
Davis-Monthan AFB, AZ	<0.0001
Holloman AFB, NM	<0.0001
McChord AFB, WA	<0.0001
McConnell AFB, KS	<0.0001
Sheppard AFB, TX	<0.0001
Vance AFB, OK	<0.0001

^a The odds of damage are based on FY 1994-1997 data on USAF bird strikes.

Table 2.28 Comparison between mean bird strike rates and odds of damage resulting from bird strikes during airfield operations involving fighter aircraft at 151-200 KIAS and “medium” birds at different USAF airfields.

Base	MAJCOM	Mean^a Rate	Odds Damage^a
Shaw AFB, SC	ACC	0.20	0.3790
Elmendorf AFB, AK	PACAF	0.24	0.3570
Tinker AFB, OK	AFMC	2.08	0.2292
Seymour-Johnson AFB, NC	ACC	0.65	0.1443
Dover AFB, DE	AMC	2.75	0.1336
Howard AFB, Panama	ACC	6.42	0.1209
Randolph AFB, TX	AETC	1.58	0.1117
Eglin AFB, FL	AFMC	0.29	0.1110
Beale AFB, CA	ACC	1.38	0.1031
Edwards AFB, CA	AFMC	1.03	0.1015
Kelly AFB, TX	AFMC	3.02	0.0863
Luke AFB, AZ	AETC	1.46	0.0827
Travis AFB, CA	AMC	1.38	0.0779
Dyess AFB, TX	ACC	1.43	0.0752
Tyndall AFB, FL	AETC	0.40	0.0638
Barksdale AFB, LA	ACC	3.91	0.0515
Patrick AFB, FL	AFSPC	1.35	0.0411
Laughlin AFB, TX	AETC	3.58	0.0386
Altus AFB, OK	AETC	4.48	0.0001
McConnell AFB, KS	AMC	3.58	<0.0001
Sheppard AFB, TX	AETC	2.12	<0.0001
Davis-Monthan AFB, AZ	ACC	1.81	<0.0001
McGuire AFB, NJ	AMC	1.77	0.0001
Columbus AFB, MS	AETC	1.64	<0.0001
Little Rock AFB, AR	ACC	1.40	0.0001
Vance AFB, OK	AETC	1.39	<0.0001
McChord AFB, WA	AMC	0.68	<0.0001
Pope AFB, NC	ACC	0.56	0.0001
Hill AFB, UT	AFMC	0.36	0.0001
Holloman AFB, NC	ACC	0.35	<0.0001
Nellis AFB, NV	ACC	0.21	0.0001

^a Mean bird strike rates and odds of damage are based on FY 1994-1997 data on USAF bird strikes.



Figure 2.1 Map of USAF airfields selected for analyses.

DISCUSSION

Computed as the number of bird strikes per 10,000 aircraft movements or hours flown, bird strike rates can indicate aircraft with a high risk of bird strike occurrence. Due at least partly to differences in design, the various aircraft groups have different strike rates. Cargo/airlift/transport aircraft had the second highest strike rate. In a study of European airline strikes, Thorpe (1990) also found that wide body commercial aircraft had a strike rate slightly above average for most aircraft groups. He suggested that factors such as frontal area, vulnerability, and position of engines most likely influence aircraft strike rates (Thorpe 1990). Because wider bodied aircraft such as cargo planes (e.g., C-130) have a greater frontal area and have multiple engines with large surface to area ratios, the odds of striking a bird are increased. Engine noise may be another factor that influences aircraft bird strike rates. Smith (1986) reported that faster and quieter wide-bodied aircraft (e.g., Boeing 747 and DC-10 aircraft) are struck 7 times more than older narrow-bodied jets (e.g., Boeing 727). Cleary et al. (1998) observed a similar pattern in analyses of 1991-1997 data on bird strikes to civil aircraft in the United States.

The type of missions flown by aircraft groups also influence aircraft strike rates. For instance, bomber aircraft had the highest strike rate; these aircraft frequently fly long missions at low altitudes where they are likely to encounter birds. Cargo aircraft, on the other hand, fly high altitude missions where they are less exposed to bird hazards. Prior analyses of data on bird strikes (Neubauer 1990) showed that aircraft that traditionally fly high-altitude missions have a smaller percentage of strikes than those with missions at lower altitudes. Similar to these findings, I found cargo/airlift/transport aircraft had a lower bird strike rate than bomber aircraft.

Although I calculated bird strike rates for selected USAF airfields, direct comparison of these strike rates can be misleading. As was determined in initial analyses of all data on USAF bird strikes, there are many factors that influence the occurrence of a strike. In addition, although the number of aircraft movements certainly is an important factor influencing the risk of a bird strike occurring on an airfield, it does not directly influence the odds of occurrence for a damaging bird strike. As previously discussed, initial risk analyses indicated that aircraft type and mission influence the odds of

occurrence for a damaging bird strike. The results from logistic regression analyses also indicated that aircraft type and mission influence the odds of a damaging bird strike occurring on an airfield, but they may appear confounding when compared with initial relative risk analyses. Initial relative risk analyses including all phases of flight indicated that bomber aircraft had the greatest risk of a damaging strike occurring, followed by fighter/attack, trainer, reconnaissance, and cargo/airlift/transport aircraft. Logistic regression analyses for only airfield operations indicated that the trainer aircraft had the greatest odds of damage, followed by bomber, cargo/airlift/transport, fighter/attack, and reconnaissance aircraft. The results of these two analyses reflect the difference in risk for the various phases of flight for USAF aircraft. Where and during which phases of flight aircraft are at risk for a damaging bird strike is at least partly influenced by aircraft types and missions. For instance, as previously stated, bomber aircraft frequently fly long missions at low altitudes where they are likely to encounter birds. In general, these aircraft had a high strike rate, but many of the strikes (46.7%, n = 1,352) to bombers were on low-level (and range) missions as opposed to on or near airfields. Hence, with respect to damage, bomber aircraft are at greater risk of incurring a damaging bird strike during low-level operations during other phases of flight. Trainers, on the other hand, perform more airfield operations and the majority (54.6%, n = 3,214) of their strikes (both damaging and non-damaging) occurred on or near the airfields. Therefore, with respect to the risk of airfield strikes, bombers have less chance of incurring a damaging bird strike because they have fewer airfield movements than trainers.

Aircraft type and mission are just 2 factors that influence the risk of the occurrence of an airfield bird strike. Abiotic factors, including season, geographic area, and time of day also can increase the odds of damaging and non-damaging bird-aircraft collisions on airfields (Blokpoel 1976, Burger 1983, Gabrey and Dolbeer 1996).

In North American there are 2 peaks during the year when there is a greater risk of a bird strike - spring and fall migration (Allan 1996). The onset of migration is associated with the change in season and is governed by the need of the birds to be in an area where they are able to find sufficient food for themselves and their young. It also is governed by birds' need to maintain a certain core body temperature whatever the air temperature and by their need to avoid predators at times of vulnerability (Jarmen 1994).

Hence, climate, latitude, temperature, and weather influence the onset of migration. In effect, the time that migration begins is not the same each year and is somewhat dependent on geographic location. Reasonably then, there are conditions and places that invite a higher risk of a bird strike at different times of the year due to migrating flocks of birds. Overall, the data on bird strikes were bimodal, showing peaks in accordance with fall and spring migrations. A similar pattern was observed in analyses of data on bird strikes to commercial aircraft in the United States (Cleary et al. 1998). When USAF data were analyzed by base, peak fall and spring bird strike months varied. For instance, Tyndall, Luke, Travis, Edwards, Holloman, and Nellis had peaks in winter months (December and/or January). Except for Travis (CA) and Nellis (NV), these are southern bases with warm and (in most cases) arid climates in the winter. Consequently, these areas are attractive to birds such as horned larks at those times.

Because certain migrating birds may weigh ≥ 10 kg and move in great flocks, the odds of damage may be greater in some areas during and following migration. For example, large flocks of tundra swans (*Cygnus columbianus*) winter in North Carolina. From mid-February to the beginning of March, these birds start their migration to Alaska and Canada and, 80-100 days later, they begin their migration back to North Carolina (T. A. Kelly, Geo Marine, personal communication). Military flight routes and airfields along the migration path may be at greater risk of incurring a damaging bird strike because of the tundra swan's large size (13-16 lbs., 5.9-7.3 kg) and the number of birds passing through. North Carolina airfields (e.g., Seymour-Johnson AFB) and bombing ranges (e.g., Dare County) also may be at increased risk during the winter because of the presence of these large birds.

In addition to the fall and spring peaks in bird strikes due to migration, a third peak was evident for some bases (e.g., Elmendorf, McChord). The third peak occurred in July and August. These are northern bases where bird activity is likely to be high in the summer months. In addition, these peaks may correspond to a time when many young birds are present, and when the flying abilities of adults may be impaired as they molt their flight feathers (Allan 1996).

Aside from migration times and routes, certain geographic factors can invite a higher risk of both damaging and non-damaging bird strikes on airfields. Local factors

such as latitude, climate, proximity to surrounding land uses (e.g., sanitary landfills, neighboring agricultural areas), and other special habitats (e.g., wetlands) may increase the risk of a bird strike. For instance, Howard AFB, Panama had a high number of airfield strikes. It also had a higher bird strike rate and greater odds of damage relative to other bases analyzed. Howard perhaps has the worst overall bird hazard of any USAF installation. The bird strike problem at Howard is attributed partly to its tropical location. Not only do hundreds of thousands of birds of all sizes pass through the isthmus of Panama during migration, but many of these birds winter there. Howard typically has a large numbers of vultures present throughout the winter. The mountainous terrain provides thermals for vultures to soar on all day. Vultures are particularly hazardous to aircraft in the traffic pattern as they leave their roosts in the mid-morning hours and as they return in the late afternoon (USAF BASH Team evaluation 1998).

The number and type of birds also influence the bird strike risk for an airfield. Buurma (1984) believes that a high bird density in the lowest air layer determines the bird strike rate. Clearly, the more birds present on or near an airfield, the greater the odds of a bird strike occurring. In addition, certain species may be more hazardous than other species. Bird strikes involving large, lone species of birds (e.g., vultures and hawks) typically result in damage. Howard AFB, Panama, had a high risk of bird strike damage. This risk corresponded to black vulture and turkey vulture strikes. Despite the hazard these birds present to aircraft, they are typically few in number and comparatively easier to clear than flocking birds on airfields (Jarmen 1994). Flocking bird species present a persistent hazard on airfields. These birds congregate on airfields. When aircraft take off or approach airfields on landing, birds are disturbed, become airborne, and often are struck by aircraft. For instance, horned larks are a persistent problem for airfields in southwestern United States (e.g., Edwards, Luke, Nellis, and Randolph). Strike incidents involving horned larks rarely result in damage to aircraft because of their small size (1.5 oz., 44 g); the only major bird strike involving horned larks occurred in 1986 when a strike with a single bird destroyed a T-38 at Randolph (FY 1986 USAF Bird Strike Data). Nevertheless, large flocks of horned larks are a hazard to aircraft. The number of bird strike incidents involving horned larks and other flocking birds can be reduced when

effective airfield bird control measures are used to reduce the number of birds on the airfields.

Flocks of gulls and shorebirds often are encountered by aircraft on airfields near the coast and large bodies of water (e.g., the Great Lakes). For example, relative to other airfields that were analyzed, Dover AFB (located along the coast of Delaware) had high numbers of airfield strikes, high bird strike rates, and greater odds of damage. The majority of the strikes where species was known involved gulls (e.g., herring gulls and laughing gulls). Gulls also are a persistent problem for many airfields, particularly when their flight paths to and from large communal roosts and or landfills cross an airfield. Their flight paths to and from food sources typically are below 1,000 ft. AGL (Lovell 1997*b*) – aircraft performing airfield operations also fly at this altitude. In addition, gulls are attracted to runways, which are excellent spots for loafing. Runways also provide an ideal surface for gulls to drop and break up bones and shells. Clearly, the presence of gulls is hazardous with respect to bird-aircraft collisions, but the pieces of bones and shells they drop on runways are additional hazards to aircraft tires and engines (Smith 1986).

Certain times of day (e.g., when birds fly to feed) may be more hazardous with respect to bird strikes. Birds' daily movements often follow set patterns. For many birds, day typically starts about an hour before dawn. Birds move away from roost sites to feeding sites and may spend hours in flight and feeding. Then birds move to resting areas. When feeding areas are near airfields this is a dangerous situation; birds may choose to rest on airfields. They will arrive during various parts of the day and will be reluctant to leave until the next feeding time. Some bird species feed throughout the night, but at dusk, or slightly later, birds move to roosting sites where they are safe from predators and from the weather (Jarmen 1994).

SUMMARY

Consistent with my analyses of all data on bird strikes during the period of FY 1988 through FY 1997, the number of bird strikes that occurred at airfields is influenced by a number of factors and the interaction of these factors (e.g., geographic location, time

of year, number of airfield movements). For instance, airfields with the highest strike rates did not necessarily have the greatest odds of damage. Other factors such as geographic location and the number and type of birds interact and influence the likelihood of damage occurring to aircraft.

With respect to damage, observations for airfield strikes during FY 1994 through FY 1997 also were similar to observations made for all strikes during FY 1988 through FY 1997. Certain factors were better predictors of the occurrence of damage than were others. For instance, given the same base and aircraft, the odds of a damaging strike occurring on/near the airfield generally increased with aircraft speed and bird size. Logistic regression analyses, as opposed to initial risk analyses, were useful in that they enabled me to simultaneously consider variables associated with damage and to predict whether damage would occur based on values of these variables.

When I analyzed airfield operations only, the number of strikes at bases ranged from 19 to 278, and small sample sizes affected the calculation of odds. For example, my analyses indicated that Shaw AFB, SC had a bird strike problem throughout more than one-half the year (i.e., April through September). Despite this bird strike problem, and relative to other bases, Shaw had a low number of airfield strikes ($n = 25$) and a low bird strike rate (0.2). One of only 25 bird strikes was damaging and as a result logistic regression analyses indicated that Shaw had the greatest odds of a damaging strike occurring. Given this problem with analyses of data on bird strikes, it is important to simultaneously consider total airfield bird strikes, airfield bird strikes, and odds of damage when making conclusions about airfield risks.

GENERAL DISCUSSION AND SUMMARY

There are many factors or variables that contribute to the occurrence of both non-damaging and damaging bird strikes. For example, analyses of the USAF data on bird strikes revealed flying conditions under which birds are most frequently encountered by aircraft. During the day and at dusk are periods of risk. Although the tactical needs of the USAF govern aircraft activity, it is possible to adjust flying times to periods when bird activity is lower.

Some of the variables that contribute to USAF bird strikes are better predictors of damage than are others. For instance, the part of the aircraft struck greatly determines the amount of damage incurred by an aircraft. Analyses of the bird strike data indicate that windshield penetrations and engine ingestions are costly to the USAF. This information as well as information about aircraft speeds and missions can help transparency and engine manufacturers improve designs so that they can better withstand bird impacts.

Although reducing the bird strike problem into elements that contribute to the occurrence of bird strikes provides useful information, this approach alone is insufficient. To fully understand and manage the bird strike problem, a multivariate approach such as logistic regression is required. For instance, the interaction of variables such as aircraft altitude, aircraft speed, and phase of flight affects the total number of strikes and whether the strikes result in damage to aircraft. I found that aircraft flying low level/range operations are at greater risk of a damaging bird strike because the mission requires that the aircraft fly at low altitude and at high speed for long periods of time.

Finally, supplemental data are necessary to fully understand the bird strike problem. Airfield and aircraft strike rates, as well as knowledge of biotic factors such as the number and type of birds in a location and abiotic factors such as climate and latitude and longitude must be obtained. When strike data variables are analyzed simultaneously and in conjunction with supplemental data, only then can the bird strike problem be fully understood and appropriate management programs be implemented. For instance, the bird strike problem at Howard AFB, Panama is perhaps the worst overall bird hazard of any USAF installation and can be attributed to a variety of factors. Relative to other airfields that I analyzed Howard had a lower number of movements, but it had a high

strike rate and a high odds of damage. The bird strike problem at Howard is attributed partly to its tropical location. Not only do hundreds of thousands of birds of all sizes pass through the isthmus of Panama during migration, but many of these birds winter there. Howard typically has a large numbers of vultures present throughout the winter. The mountainous terrain provides thermals for vultures to soar on all day. Vultures are particularly hazardous to aircraft in the traffic pattern as the birds leave their roosts in the mid-morning hours and as they return in late afternoon. In short, abiotic and biotic factors as well as aircraft flight hours, airfield movements, and aircraft and airfield bird strike rates must be considered simultaneously in order to completely assess the bird strike problem at Howard and other USAF installations.

When these simultaneous analyses are performed and the bird strike problem is assessed, specific management actions can decrease the number of both damaging and non-damaging USAF bird strikes. For instance, my analyses indicated that, for the period of FY 1994-1997, training bases such as Altus AFB, OK, Randolph AFB, TX, and Laughlin AFB, TX had a greater number of bird strikes than other bases I evaluated. These bases fly aircraft such as T-38, T-37, and T-1A that are used primarily for undergraduate pilot and pilot instructor training. Because of their mission, all training bases have relatively high airfield movement counts, high bird strike counts, and, consequently, high bird strike rates. In contrast, many non-training bases have fewer airfield movements because their mission supports greater flight hours away from the airfield. Another reason that training bases have a high number of strikes is that most of these training bases are in the southeast and southwest portions of the United States. The climates and habitats support large bird populations throughout most of the year. With greater numbers of birds in the vicinity of these training bases, bird strikes are more likely to occur. Training bases had high odds of damage. The high odds of damage may be related to a number of factors. For instance, T-38 aircraft have a large transparency relative to the aircraft size. A number of aircraft have been destroyed due to the penetration of a bird(s) through the transparency.

Although training bases will not be moved and their airfield movements will not be decreased because of the bird strike problem, knowledge about the factors that

contribute to the bird strike problem can help the USAF manage airfields to reduce the number of damaging and non-damaging bird strikes.

SUMMARY

The evaluation of the USAF bird strike database represents a substantial examination of the bird strike problem as it relates to the modern Air Force. Summary data and prediction of the odds for damaging bird strikes are useful and will suggest prescriptive courses of action. Although little comparative data exist in the literature the general patterns I observed seem to continue trends described following an earlier examination of USAF bird strike data (Neubauer 1990). Differences are evident in patterns for bird strikes between commercial aviation (Cleary et al. 1998) and military operations, and these patterns may allow better insights into relationships between bird behavior and aircraft at airfields.

RECOMMENDATIONS

SHORTCOMINGS IN THE DATA COLLECTION PROCESS

Throughout my analysis of the strike data, I encountered many shortcomings in the collection of data on USAF bird strikes. During the period of FY 1988 through FY 1997 data on USAF bird strikes were reported on AF Form 853. Both the first and second versions of this form are inadequate with respect to current data-processing standards; AF Form 853 was not explicit as to exactly what information was being requested and allowed for free-form entry of text. For instance, the form requested aircraft type (e.g., F-15 E). However, entries typically ranged from being incomplete (e.g., F-15) to inappropriate (e.g., tail number of a specific aircraft). Another problem with the collection process was that bird strike data reported on AF Form 853 had to be entered into the bird strike database by the USAF BASH Team. Data entry was time consuming and compromised the integrity of the data (i.e., data often were entered inaccurately and there were discrepancies in the way certain information was entered).

I initially spent considerable time correcting mistakes (e.g., misspellings) in the data and improving data consistency (e.g., all locations entered by the same standard: Name AFB, State Abbreviation). In addition, I found it necessary to code data by number. These time consuming efforts were a necessary first step before I could analyze data using Microsoft Access and statistical software packages such as SPSS.

Since I began this study, the process of collecting data on USAF bird strikes has been improved. The USAF BASH Team recently was allowed to transfer the bird strike database into Microsoft Access. With this change, it became possible to create an electronic data entry form easily accessible to USAF personnel. The new form, created by Lt. Curt Burney of the USAF BASH Team, was designed with data processing controls that ensure data consistency (e.g., lists of appropriate data to restrict entries). In addition, the new reporting process maintains data integrity; electronic reporting is less time-consuming for the BASH Team and it ensures that data is entered accurately into the bird strike database.

Despite these improvements, I recommend that some of the bird strike information reported be restructured and coded to facilitate analysis with statistical software packages such as SPSS. Specifically, bird groups should be designated and entered at the time of bird species identification. Birds should be assigned to recognized groups of bird species, behavior (e.g., flocking behavior, migrating species, food preference), and/or size. In assigning bird groups, general analyses can be performed with respect to the type of hazard these birds present to aircraft.

In the present study, regions (e.g., Europe, Pacific) were designated to initially determine areas of the United States and world with the greatest bird strike problems. I designated regional blocks according to latitude and longitude and analyzed bird strikes by region. Although I was able to identify regions with a high number of bird strike incidents, I did not make any conclusions about bird groups in these regions because the regions were too large and by necessity somewhat arbitrarily designated. Consequently, I concluded that the region variable was not very useful in my analyses. The type of analysis that I attempted is possible with the USAF BAM. The BAM is capable of identifying areas of high bird activity in the United States that are hazardous to aircraft. The addition of data on bird strikes, data on the odds of the occurrence of damaging bird strikes, and supplemental data on aircraft flight hours and airfield movements could improve the model's assessment of the bird strike risk in some areas of the United States. In the future it should be possible to enter data into the BAM and identify where and when bird groups or species of birds are likely to be a hazard to aircraft and what habitats would support them.

Time is a misleading variable due to daylight savings time, time zones, and the fact that latitude, longitude, and time of year affect the designation of dusk and dawn times differently. Although the exact time usually was noted in data on bird strikes, for purposes of determining what time of day (i.e., dawn, day, dusk, night) was most hazardous, the time of day variable was used. Values for this variables are determined by pilots and may not be useful (e.g., it is subjectively determined whether it was day or dusk). Greenwich Mean Time may be a better way of reporting time of incident so that more accurate comparisons can be made between bird strike locations throughout the world. The strike data could be combined with data on sunset and sunrise times

throughout the year. Such an analysis would present a clearer picture as to the times of greatest bird hazards.

Refining data collection will furnish higher quality, more useful data. With these improvements, the BASH Team will be able to regularly analyze the data on bird strikes and use these analyses to better manage bird strike problems at USAF installations and to aim research efforts at preventing bird strikes.

INCREASED AND MORE DETAILED REPORTING

There is a need for increased and more detailed reporting of bird strikes. As Jarmen (1994) stated, accurate record keeping is essential if any idea of the long-term trends in bird activity and bird-related mishaps are to be found. There are two specific areas of reporting of data on USAF bird strikes that presently are not sufficient: amount of aircraft damage and species of bird involved.

Reporting of the cost of aircraft damage due to bird strikes generally is not comprehensive. Most air forces, including the USAF, calculate only the direct cost of damage to the aircraft and its parts. Manpower costs related to obtaining parts, repairing damages, and investigating mishaps often are not included (Donoghue 1996, MacKinnon 1996a). The true costs associated with bird strikes must include actual damage, replacement parts, costs of manpower, loss of use of equipment, and other indirect costs (Donoghue 1996, MacKinnon 1996a). The true costs of USAF bird strike incidents probably are much greater than that reported and, consequently, the number of damaging bird strikes – those costing the USAF \geq \$10,000 – most likely is much greater than that reported. Underestimation of the number of damaging bird strikes, and costs related to them, certainly affects analyses of data on bird strikes (i.e., the odds of occurrence for a damaging strike on airfields likely are greater than those determined in my analyses).

Some knowledge of bird species involved was available in only 28.6% of bird strikes involving USAF aircraft. Greater emphasis and effort must be placed on the collection of bird remains so that more identifications can be made. With more identifications and with strike data organized by bird groups, strike data can be used to show which bird groups are a problem in different areas of the world. Further analyses

by species may reveal close similarities with other survey data (i.e., BBS and CBC), indicating where birds are, when they are there, and, to some degree, the abundance of that species in that area. An increase in the number of identifications can help the USAF better manage airfields and prevent future bird strikes. For instance, all of the USAF airfields that I analyzed had a proportionately large number of strikes in which the species of bird involved was either unknown or only speculated upon (e.g., blackbirds). Clearly, it is difficult to manage a problem that is not well understood.

COLLECTION OF SUPPLEMENTAL DATA

Although increased and more detailed reporting of bird strikes, as well as improvements in the data collection process, certainly will aid future analyses, the collection and analysis of supplemental data such as aircraft low level flight hours and airfield movements, also is necessary. Analyzing these data in conjunction with data on bird strikes to USAF aircraft can improve the USAF's understanding of the bird strike problem.

Airfield Movement Data

Responsibility for airfield movement data recently has been assumed by the Air Force Flight Standards Agency (AFFSA). For my analyses, only the annual totals of airfield movements were available for most USAF bases. For the purpose of bird strike risk assessment at airfields, it would have been useful to look at airfield movements by hour of the day or at least time periods (e.g., 0600-1200). In addition, it would have been useful to look at airfield movements by month or day of the year (i.e., Julian date). USAF bases collect airfield movement data on a daily basis and by different periods of the day, but in the past these data have not been recorded and maintained at the USAF level; only data on annual airfield movements currently are available electronically. Fortunately, the process of collecting these data from USAF bases is being revised and daily counts for time periods of the day could be included in the new process. With these data available, future logistic regression analyses could include time of year and day and

comparisons could be made to corresponding strike rates. This would allow the USAF to determine, with respect to the bird strike hazard, which airfields are at greatest risk at a given time of year and time of day. In short, examining airfield bird strike rates at different times of day and at different times of year would allow bird control that is sensitive to changing conditions (Burger1983). Both the airfield movement data and subsequent strike data analyses would be useful supplements to the USAF BAM.

Low-level route flight hours

As previously discussed, the calculation of low-level bird strike rates originally was a goal of my study. I envisioned that low-level bird strike rates could be supplemental data helpful to the USAF BAM in evaluating the bird strike risk for low-level routes in the United States. However, there were insufficient low-level flight hour data and bird strike data to allow for the calculation of low-level route bird strike rates. According to the Military Airspace Management Systems (MASMS) at Offutt AFB, NE, the process by which low-level flight hours are tracked currently is being improved. In the future, once these changes have been made, and if more bird strikes reported as having occurred during low-level operations include the low-level route that was flown, the number of bird strikes per low-level route may be determined accurately.

WILDLIFE MANAGEMENT PERSONNEL ON USAF AIRFIELDS

Most USAF airfields do not have trained wildlife personnel managing their bird strike prevention programs. These programs typically are assigned to safety and airfield personnel who do not have the qualifications, time, and desire to adequately deal with the bird strike problem. If the USAF created officer and enlisted or civilian government positions at each airfield for trained wildlife personnel, safety and aviation personnel would be better able to perform their primary duties. In addition, trained wildlife personnel would be better able manage the habitat on airfields to decrease the presence of birds and other wildlife. These personnel would be able to identify problem species, consider how habitat changes to manage one species may alter the number and activity of other species on airfields, and rely on their knowledge and experience to determine the

best management options. For instance, trained wildlife personnel would be able to better recognize potential problems such as stands of pines that could be used for night roosting by starlings and blackbirds. In addition, they would be able to determine how best to manage airfield grasses to decrease the number of seed-eating and ground-feeding birds without dramatically increasing the number of large soaring birds. Trained wildlife personnel also are better able to identify birds that present a hazard to aircraft, determine their food source, and reduce or eliminate that food source (i.e., spray insecticides to eliminate insects eaten by killdeer). In addition, trained wildlife personnel could improve the collection of data on bird strikes and the physical evidence relating to these strikes. These data could be analyzed annually and used to re-assess the local bird strike problem and make appropriate bird management changes. In short, the addition of trained wildlife personnel at USAF airfields would decrease the overall number of strikes on airfields and the amount of monetary damage incurred by the USAF.

LITERATURE CITED

- Allan, J. R. 1996. Bird strike statistics can be meaningful: The CSL analysis. Presented at the 6th annual meeting of the Bird Strike Committee-USA. Phoenix, Arizona, USA.
- Aronoff, S. 1993. Geographic information systems: a management perspective. WDL Publications. Ottawa, Canada.
- Blohm, R. 1998. Canada geese and snow geese – Reassessing traditional paradigms for management. Presented at the 8th annual meeting of the Bird Strike Committee-USA. Cleveland, Ohio, USA.
- Blokpoel, H. 1976. Bird hazards to aircraft. Clarke, Irwin and Company, Ottawa, Canada. 235 pp.
- Bohrnstedt, G. W., and D. Knoke. 1994. Statistics for social data analysis. F. E. Peacock Publishers, Itasca, Illinois, USA. 574 pp.
- Burger, J. 1983. Bird control at airports. *Environmental Conservation* 10(2):115-124.
- Buurma, [L.] S. 1984. Key factors determining birdstrike and risks. *International Journal of Aviation Safety* 2(1):91-107.
- Burney, C. 1998. GIS-base bird avoidance model. Presented at the 8th annual meeting of the Bird Strike Committee-USA. Cleveland, Ohio, USA.
- Cleary, E. C., S. E. Wright, and R. A. Dolbeer. 1996. Wildlife strikes to civil aircraft in the United States 1993-1995. U.S. Department of Transportation, Federal Aviation Administration, Wildlife Aircraft Strike Database, Serial Report – Number 2. 33 pp.
- Cleary, E. C., S. E. Wright, and R. A. Dolbeer . 1998. Wildlife strikes to civil aircraft in the United States 1991-1997. U.S. Department of Transportation, Federal

- Aviation Administration, Wildlife Aircraft Strike Database, Serial Report – Number 4. 34 pp.
- DeFusco, R.P. 1993. Modeling bird hazards to aircraft: A GIS application study. *Photogrammetric Engineering & Remote Sensing* LIX:1481-1487.
- Dolbeer, R. A. 1997. Feathered and furry FOD – A serious problem at U.S. airports. Presented at the National Aerospace FOD Prevention Conference, Seattle, Washington, USA.
- Donoghue, J. A. 1996. Sharing the skies. *Air Transport World* 33:55-62.
- Dove, C. 1996. Bird strike identification and proper collection of feathers. Presented at the 6th Annual Meeting of Bird Strike Committee-USA. Phoenix, Arizona, USA.
- Dwyer, C. P., J. L. Belant, and R. A. Dolbeer. 1996. Distribution and abundance of roof-nesting gulls in the Great Lakes region of the United States. *Ohio Journal of Science* 96:9-12.
- Gabrey, S. W., and R. A. Dolbeer. 1996. Rainfall effects on bird – Aircraft collisions at two United States airports. *Wildlife Society Bulletin* 24:272-275.
- GAO. 1989. Reducing risks to military aircraft from bird collisions. GAO/NSIAD-89-127. U. S. General Accounting Office, Washington, D.C., USA. 21 pp.
- Jarmen, P. 1993. A manual of airfield bird control. Birdcheck, United Kingdom.
- Klinger, D. 1982. Department of the Interior news release, U.S. Fish and Wildlife Service, March 10.
- Krzysik, A.J. 1987. A review of bird pests and their management. September Final Report. Prepared for Department of the Army, U.S. Army Corps of Engineers. Repair, Evaluation, Maintenance, and Rehabilitation Research Program Technical Report REMRM-1. Washington, D.C, USA.
- Langley, M. 1970. The birdstrike problem. *Science Journal (London)* 6(8):55-60.

- Lewis, C.M. Jr. 1995. Engine bird ingestion. *Airliner* Jan-Mar: 17-23
- Lovell, C. D. 1997*a*. The U.S. Air Force bird avoidance model for low-level training flights. *Great Plains Wildlife Damage Control Workshop*. 13:162-170.
- _____. 1997*b*. Where the birds are. *Approach* 42:14a-15a.
- _____. and V. Stella. 1997. Aircraft vs. birds – How to win the war. *Approach* 42:36-37.
- MacKinnon, B. 1996*a*. Large birds: A growing risk. *Transport Canada Airport Wildlife Management, Bulletin* 18:1-3.
- _____. 1996*b*. New technologies in wildlife control. *Transport Canada Airport Wildlife Management, Bulletin* 19:1-3.
- Merritt, R. L. and J. J. Short. 1994. Bird strike hazards: Support for a 4.5 pound bird test criteria. *Proceedings of the Conference on Aerospace Transparent Materials and Enclosures*. 2:815-821.
- Microsoft Corporation. 1996. *Getting results with Microsoft Office 97*. Redmond, Washington, USA. 584 pp.
- Neubauer, J. C. 1990. Why birds kill: Cross-sectional analysis of U.S. Air Force bird strike data. *Aviation, Space, and Environmental Medicine*. 61:343-348.
- NTSB. 1998. Accident, fatalities, and rates, 1997 preliminary statistics, U.S. aviation. www.nts.gov/aviation/table1.htm.
- Peterjohn, B. G., J. R. Sauer, and W. A. Link. 1994. The 1992 and 1993 summary of the North American breeding bird survey. *Bird Populations* 2:46-61.
- Pilo, B., A. Kumar, S. Oommen, and K. R. Vinod. 1994. Anti-bird collision strobe lights: field experiments on indian birds. *Proceedings of the Bird Strike Committee Europe*. 22: 69-72.

- Richardson, W. J. 1994. Serious birdstrike-related accidents to military aircraft of ten countries: preliminary analysis of circumstances. *Proceedings of the Bird Strike Committee Europe* 21:129-152.
- Smith, M. 1986. From strike to kill. *New Scientist* 110:44-47.
- Solman, V. E. F. 1970. Current work on bird hazards to aircraft. *Proceedings of the Vertebrate Pest Conference* 4:184-187.
- _____. 1971. Bird control and air safety. In *Studies of bird hazards to aircraft*, Canadian Wildlife Service Report Series 14:8-14.
- _____. 1973. Birds and aircraft. *Biological Conservation* 5(2):79-86.
- _____. 1978. Gulls and aircraft. *Environmental Conservation* 5:277-280.
- _____. 1981. Birds and aviation. *Environmental Conservation* 8:45-51.
- SPSS Inc. 1993. *SPSS for windows: Base system user's guide*, Release 6.0. SPSS Inc., Chicago, Illinois, USA. 828 pp.
- _____. 1997. *SPSS professional statistics 7.5*. SPSS Inc., Chicago, Illinois, USA. 276 pp.
- _____. 1998. *SPSS base 8.0 applications guide*. SPSS Inc., Chicago, Illinois, USA. 372 pp.
- Steenblik, J. W. 1997. Wildlife hazards to aircraft. *Air Line Pilot* 66:30-33, 62.
- Stokes, M. E., C. S. Davis, and G. G. Koch. 1995. *Categorical data analysis using the SAS system*. SAS Institute Inc., Cary, NC, USA. 499 pp.
- Thorpe, J. W. 1990. Analysis of bird strikes reported by European airlines 1981-1985. *Proceedings of the Bird Strike Committee Europe* 20:263-301.
- _____. 1996. Fatalities and destroyed civil aircraft due to bird strikes, 1912-1995. *Proceedings of Bird Strike Committee Europe*. 23:17-31.

USAF BASH Team evaluation. 1998. Personal interview.

USAF Safety Center. 1995. Elmendorf AFB, AK E-3 Mishap.

USAF Safety Center. 1998. USAF aircraft flight hour data.

Wright, S. 1997. Canada geese: Flying elephants we must avoid! FAA Aviation News.
36: 1-5.

APPENDIX A. DESCRIPTION OF USAF BIRD STRIKE DATA VARIABLES

Table A.1 Original USAF bird strike database info structure.

FIELD	TYPE	SIZE	DESCRIPTION
Location	A*	40	Location of Strike
Date	D		Date of Strike
Impact	A	30	Point of Impact on the Aircraft
Species	A	40	Species Struck
Speed	S		Aircraft Speed in KIAS
Call #	N		BASH Feather Identification Number
ICAO	A	4	Identifier of Airfield where strike occurred
RepICAO	A	4	Identifier of Airfield owning the aircraft
MAJCOM	A	6	Major Command of the Airfield
AC_TYPE	A	2	Type of Aircraft (i.e., Fighter, Bomber)
AC_SER	A	3	Aircraft Series (i.e., 16, 52)
AC_MODEL	A	3	Aircraft Model (i.e., A, B, C)
LT_CODE	A	1	Time of Day when strike occurred (i.e., day, night, dawn, dusk)
PH_OF_FL	A	2	Phase of Flight (i.e., low-level, take-off, landing)
AGL	N		Altitude of strike in AGL
NO_BIRDS	A	1	Number of birds struck (single or flock)
IMP_CODE	A	1	Code of first impact point
IMP2_CODE	A	1	Code of second impact point
IMP3_CODE	A	1	Code of third impact point
IMP4_CODE	A	1	Code of forth impact point
IMP5_CODE	A	1	Code of fifth impact point
LLROUTE	A	7	Low-level route flown
REMARKS	A	50	Additional information about the strike
Time	S		Time of strike
LAT	N		Latitude of strike
LAT_N_S	A	1	North or South
LONG	N		Longitude of Strike
LONG_E_W	A	1	East or West
COST	N		Cost of damage
CLASS	A	1	Class of damage/cost (i.e., A, B, C, or Non-damaging)
FL_PATH	A	2	Flight path in relation to clouds (i.e., above, below)
LANDING	A	1	Landing lights on or off
STROBE	A	1	Strobe lights on or off
BRD_OZ	N		Weight of species struck
BirdType	A	30	Order of species struck

* Types of fields include Alpha (A), Number (N), and Short (S).

Table A.2 Variables used in analyses.

Variable Description	Variable	Variable Type	# Cat	Collapsed Variables^a	# Cat	Collapsed Variables^a	# Cat
Aircraft Altitude	ALTCAT	Continuous		ALTCAT10	1-10		
Aircraft Speed	SPEEDNO	Continuous		SPEEDCAT	1-7	KNOTS300	0, 1
Bird Weight	WEIGHT	Continuous		WEIGHTCA	1-4		
Strike date	JULDATE	Continuous	1-366	MONTH	1-12	YEAR	1-10
Aircraft damage	DAMAGE	Continuous		ABC	0, 1		
Aircraft group	ACGRP	Categorical	1-6				
Bird group	GROUP	Categorical	1-20	BIRDS	1-14		
Region of the world	REGION	Categorical	1-12	BASE	1-32		
Time of day	TIMECAT	Categorical	1-4				
Aircraft path wrt clouds	PATH	Categorical	1-5	PATH2	0, 1		
Impact point on the aircraft	IMPACTPT	Categorical	1-16	IMPACT3	1-3		
Landing lights on	LANDLITE	Categorical	0, 1				
Phase of flight	PHASE	Categorical	1-10	PHASE3	1-3		

^a Collapsed variables are all categorical.

Variable Descriptions

Aircraft Speed (SPEEDCAT)

In knots indicated airspeed (KIAS)

1	0-50
2	51-100
3	101-150
4	151-200
5	201-250
6	251-300
7	301 & up

Aircraft Altitude (ALTCAT10)

In ft. above ground level (AGL)

1	0-500 ft. AGL
2	501-1,000 ft. AGL
3	1,001-1,500 ft. AGL
4	1,501-2,000 ft. AGL
5	2,001-2,500 ft. AGL
6	2,501-3,000 ft. AGL
7	3,001-3,500 ft. AGL
8	3,501-4,000 ft. AGL
9	4,001-6,000 ft. AGL
10	>6,000 ft. AGL

Bird Weight or size (WEIGHTCA)

1	Small	0-<10 oz
2	Small-medium	10-<20 oz
3	Medium	20-<40 oz
4	Large	≥40 oz

Strike Date (MONTH)

- 1 Jan
- 2 Feb
- 3 Mar
- 4 Apr
- 5 May
- 6 June
- 7 July
- 8 Aug
- 9 Sep
- 10 Oct
- 11 Nov
- 12 Dec

Strike Date (YEAR)

- 1 1988
- 2 1989
- 3 1990
- 4 1991
- 5 1992
- 6 1993
- 7 1994
- 8 1995
- 9 1996
- 10 1997

Aircraft Damage

DAMAGE

- 0 N \$0-9,999
- 1 C \$10,000-199,999
- 2 B \$200,000-999,999
- 3 A \$1,000,000 & up/DEATH

ABC

- 0 Non-damaging (N)
- 1 Damaging (A, B, or C)

Aircraft Group (ACGRP)

Aircraft with ≥ 10 strikes included in analyses.

- 1 Fighter/attack
- 2 Cargo/airlift/transport
- 3 Trainer
- 4 Bomber
- 5 Reconnaissance
- 6 Other

Fighter/Attack:

A-6
A-7
AC-130
F-14
F-15
F-16
F-18
F-111
F-117
FA-18
OA-10
OA-37
P-3

Cargo/Airlift/Transport:

C-2 C-137
C-5 C-141
C-9 DC-9
C-12 HC-130
C-17 KC-10
C-18 KC-130
C-20 KC-135
C-21 MC-130
C-23
C-26
C-27
C-130
C-135

Trainer:

A-37
AT-38
CT-43
T-1
T-3
T-37
T-38
T-39
T-43
TA-4
TC-18
TC-135

Bomber:

B-1
B-2
B-52
FB-111

Reconnaissance/Surveillance:

E-2
E-3
E-4
E-6
E-8
EC-130
EF-111
OV-10
RC-135
RF-4
U-2
WC-130
WC-135

Bird group (BIRDS)

1	Crows and Ravens	8	Shorebirds
2	Ducks	9	Waders
3	Geese and Swans	10	American Robins
4	Pelicans	11	Horned Larks
5	Gulls	12	Doves
6	Raptors and Owls	13	Swallows and Swifts
7	Blackbirds and Starlings	14	Other Birds

Crows and Ravens

American crow	(<i>Corvus brachyrhynchos</i>)
Fish crow	(<i>Corvus ossifragus</i>)
Hooded crow	(<i>Corvus corone</i>)
Rook	(<i>Corvus frugilegus</i>)
Common raven	(<i>Corvus corax</i>)

Ducks

Mallard	(<i>Anas platyrhynchos</i>)
American black duck	(<i>Anas rufipes</i>)
Northern pintail	(<i>Anas acuta</i>)
Gadwall	(<i>Anas strepera</i>)
American Wigeon	(<i>Anas americana</i>)
Northern Shoveler	(<i>Anas clypeata</i>)
Blue-winged teal	(<i>Anas discors</i>)
Green-winged teal	(<i>Anas crecca</i>)
Redhead	(<i>Aythya americana</i>)
Greater Scaup	(<i>Aythya marila</i>)

Geese and Swans

Canada goose	(<i>Branta canadensis</i>)
Greater white-fronted goose	(<i>Anser albifrons</i>)
Snow goose	(<i>Chen caerulescens</i>)
Tundra swan	(<i>Cygnus columbianus</i>)

Pelicans

Brown pelican	(<i>Pelecanus occidentalis</i>)
American white pelican	(<i>Pelecanus erythrorhynchos</i>)
Double-crested cormorants	(<i>Phalacrocorax auritus</i>)

Gulls

Great black-backed gull	(<i>Marus marinus</i>)
Herring gull	(<i>Larus argentatus</i>)
California gull	(<i>Larus californicus</i>)
Ring-billed gull	(<i>Larus delawarensis</i>)
Laughing gull	(<i>Larus atricilla</i>)
Franklin's gull	(<i>Larus pipixcan</i>)
Mew gull	(<i>Larus canus</i>)
Glaucous gull	(<i>Larus hyperboreus</i>)
Lesser black-backed gull	(<i>Larus fuscus</i>)
Black-headed gull	(<i>Larus ridibundus</i>)
Black-tailed gull	(<i>Larus crassirostris</i>)
Little gull	(<i>Larus minutus</i>)

Raptors and Owls

Turkey vulture	(<i>Cathartes aura</i>)
Black vulture	(<i>Coragyps atratus</i>)
Northern harrier	(<i>Circus cyaneus</i>)
Red-tailed hawk	(<i>Buteo jamaicensis</i>)
Swainson's hawk	(<i>Buteo swainsoni</i>)
Broad-winged hawk	(<i>Buteo platypterus</i>)
Golden eagle	(<i>Aquila chrysaetos</i>)
Bald eagle	(<i>Haliaeetus leucocephalus</i>)
American kestrel	(<i>Falco sparverius</i>)
Cooper's hawk	(<i>Accipiter cooperii</i>)
Sharp-shinned hawk	(<i>Accipiter striatus</i>)
Ferruginous hawk	(<i>Buteo regalis</i>)
Rough-legged hawk	(<i>Buteo lagopus</i>)
Red-shouldered hawk	(<i>Buteo lineatus</i>)
Mississippi kite	(<i>Ictinia mississippiensis</i>)
Merlin	(<i>Falco columbarius</i>)
Buzzard	(<i>Buteo buteo</i>)
Barn owl	(<i>Tyto alba</i>)
Burrowing owl	(<i>Athene cunicularia</i>)
Great horned owl	(<i>Bubo virginianus</i>)
Little owl	(<i>Athene noctua</i>)
Long-eared owl	(<i>Asio otus</i>)
Eastern screech owl	(<i>Otus asio</i>)
Western screech owl	(<i>Otus kennicottii</i>)
Short-eared owl	(<i>Asio flammeus</i>)
Snowy owl	(<i>Nyctea scandiaca</i>)
Common nighthawk	(<i>Chordeiles minor</i>)
Lesser nighthawk	(<i>Chordeiles accutipennis</i>)

Chinese goshawk	(<i>Accipiter soloensis</i>)
Northern goshawk	(<i>Accipiter gentilis</i>)
Eurasian sparrowhawk	(<i>Accipiter nisus</i>)
Japanese sparrowhawk	(<i>Accipiter gularis</i>)
Sparrowhawk	(<i>Accipiter nisus</i>)
Sea eagle	(<i>Haliaeetus</i> spp.)
Brown harrier eagle	(<i>Circaetus cinereus</i>)
Eurasian kestrel	(<i>Falco tinnunculus</i>)
Common kestrel	(<i>Falco tinnunculus</i>)
Great Philippine eagle	(<i>Pithecophaga jefferyi</i>)
Hawaiian hawk	(<i>Buteo solitarius</i>)
Griffon vulture	(<i>Gyps fulvus</i>)
Hobby	(<i>Falco subbuteo</i>)
Peregrine falcon	(<i>Falco peregrinus</i>)
Prairie falcon	(<i>Falco mexicanus</i>)

Blackbirds and Starlings

European starling	(<i>Sturnus vulgaris</i>)
Eastern meadowlark	(<i>Sturnella magna</i>)
Western meadowlark	(<i>Sturnella neglecta</i>)
Yellow-headed blackbird	(<i>Xanthocephalus xanthocephalus</i>)
Red-winged blackbird	(<i>Agelaius phoeniceus</i>)
Tricolored blackbird	(<i>Agelaius tricolor</i>)
Brewer's blackbird	(<i>Euphagus cyanocephalus</i>)
Brown-headed cowbird	(<i>Molothrus ater</i>)
Rusty blackbird	(<i>Euphagus carolinus</i>)
Common grackle	(<i>Quiscalus quiscula</i>)
Boat-tailed grackle	(<i>Quiscalus major</i>)
Great-tailed grackle	(<i>Quiscalus mexicanus</i>)

Shorebirds

Upland sandpipers	(<i>Bartramia longicauda</i>)
Killdeer	(<i>Charadrius vociferus</i>)
Least sandpiper	(<i>Calidris minutilla</i>)
Semipalmated sandpiper	(<i>Calidris pusilla</i>)
Western sandpiper	(<i>Calidris mauri</i>)
Baird's sandpiper	(<i>Calidris bairdii</i>)
Buff-breasted sandpiper	(<i>Tryngites subruficollis</i>)
Lesser sandpiper	(<i>Calidris minutilla</i>)
Pectoral sandpiper	(<i>Calidris melanotos</i>)
Spotted sandpiper	(<i>Actitis macularia</i>)
American golden plover	(<i>Pluvialis dominica</i>)
Black-bellied plover	(<i>Pluvialis squatarola</i>)
Kentish plover	(<i>Charadrius alexandrinus</i>)

Lesser golden plover	(<i>Pluvialis dominica</i>)
Little-ringed plover	(<i>Charadrius dubius</i>)
Pacific golden plover	(<i>Pluvialis fulva</i>)
Semipalmated plover	(<i>Charadrius semipalmatus</i>)

Waders

Great blue heron	(<i>Ardea herodias</i>)
Little blue heron	(<i>Egretta caerulea</i>)
Great egret	(<i>Casmerodius albus</i>)
Snowy egret	(<i>Egretta thula</i>)
Black-crowned night heron	(<i>Nycticorax nycticorax</i>)
Glossy ibis	(<i>Plegadis falcinellus</i>)
White ibis	(<i>Eudocimus albus</i>)
Wood stork	(<i>Mycteria americana</i>)
Gray heron	(<i>Ardea cinerea</i>)
Cattle egret	(<i>Bubulcus ibis</i>)
Sandhill crane	(<i>Grus canadensis</i>)

Doves

Mourning dove	(<i>Zenaida macroura</i>)
Rock dove	(<i>Columba livia</i>)

Swallows and swifts

Alpine swift	(<i>Apus melba</i>)
Bank swallow	(<i>Riparia riparia</i>)
Barn swallow	(<i>Hirundo rustica</i>)
Chimney swift	(<i>Chaetura pelagica</i>)
Cliff swallow	(<i>Hirundo pyrrhonota</i>)
Red-rumped swallow	(<i>Hirundo daurica</i>)
Northern rough-winged swallow	(<i>Stelgidopteryx serripennis</i>)
Tree swallow	(<i>Tachycineta bicolor</i>)
Vaux's swift	(<i>Chaetura vauxi</i>)
White-rumped swift	(<i>Apus caffer</i>)
White-throated swift	(<i>Aeronautes saxatalis</i>)

Region of the world (REGION)

NE United States	1	40-50 N, 60-100 W	USNE
SE United States	2	24-40 N, 60-100 W	USSE
NW United States	3	40-50 N, 100-130 W	USNW
SW United States	4	29-40 N, 100-130 W	USSW
Pacific	5	150 E-130 W	PACIFIC
Canada	6	>50 N, 60-130 W	CANADA
Far East	7	60-150 E	EAST
Middle East	8	10-40 N, 30-60 E	MIDDLE EAST
Europe	9	>35 N, 10 W-30 E	EUROPE
Atlantic	10	10 W-60 W	ATLANTIC
South of US	11	<24 N, 60-130 W	SOUTH
Africa	12	<35 N, 10 W-30 E	AFRICA

Time of Day (TIMECAT)

As reported by pilots.

1	Dawn
2	Day
3	Dusk
4	Night

Aircraft path with respect to clouds

PATH

1	Clear
2	In Clouds
3	Between Layers
4	Above Clouds
5	Below Clouds

PATH3

1	Clear
2	Not Clear

Point of impact on aircraft

IMPACTPT

- 1 Inside Engine
- 2 Outside Engine
- 3 Fuselage/Antenna/Skin
- 4 Radome/Nose
- 5 Windshield/Canopy
- 6 Tail/Stabilizer/Rudder
- 7 Weapons/Missile Pod
- 8 Landing Gear
- 9 Lights
- 10 Wings
- 11 Fuel Tanks
- 12 Propellers
- 13 ECM Pod/Pylons
- 14 Multiple Points
- 15 Rotor
- 16 Windshield Penetration

IMPACT3

- 1 Engine
- 2 Windscreen
- 3 Other

Aircraft phase of flight

PHASE

- 1 Climb
- 2 Cruise
- 3 Descent
- 4 Final Approach
- 5 Landing
- 6 Low-Level
- 7 Missed Approach/Touch & Go
- 8 Range
- 9 Take-Off
- 10 Traffic Pattern

PHASE3

- 1 Airfield
- 2 Low-level/Range
- 3 Other

APPENDIX B. AIRCRAFT ENGINE FIGURES

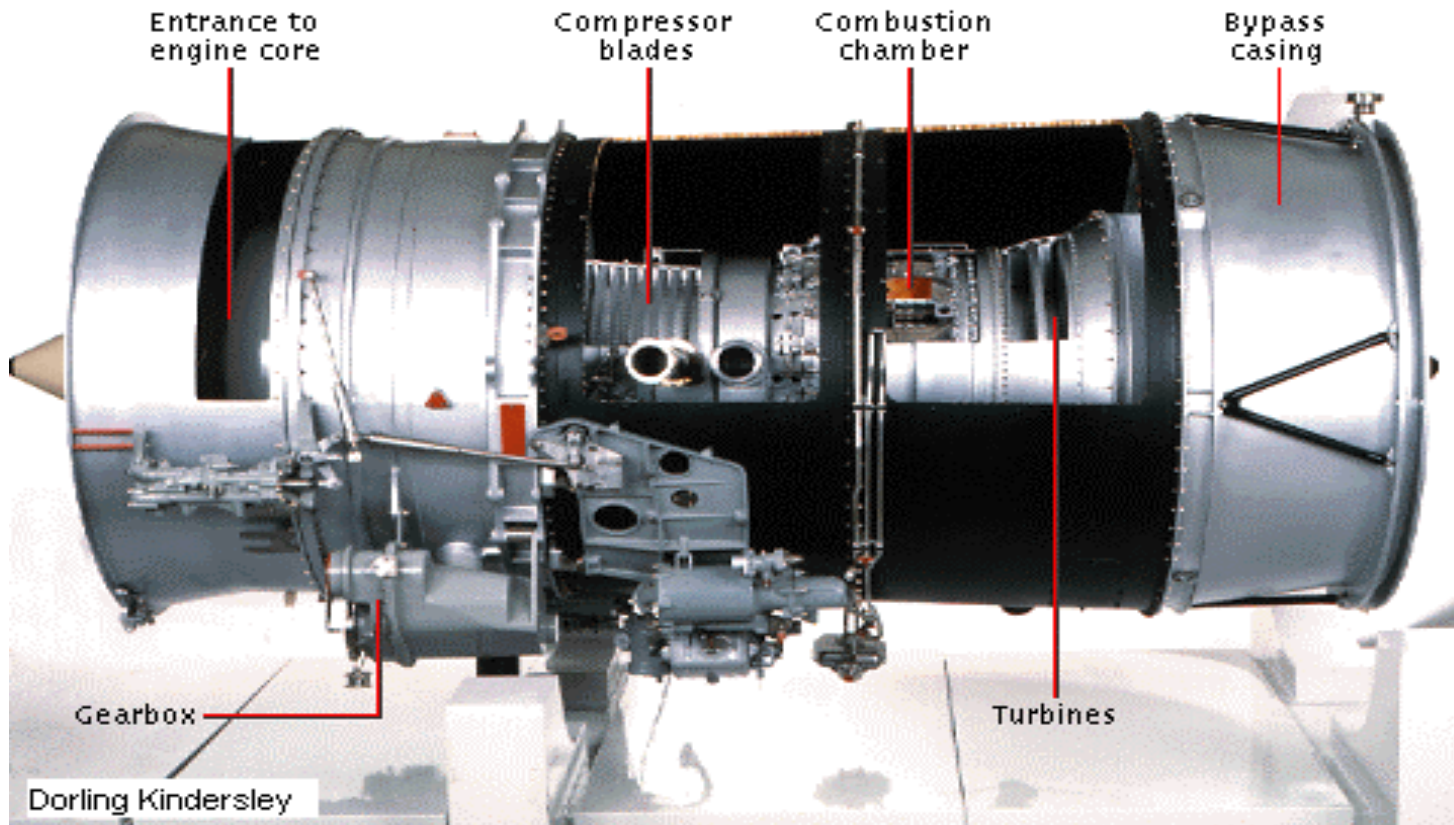

Figure A.1 Turbofan Engine

This Rolls-Royce Tay turbofan engine pushes nearly three times as much air through the bypass ducts as it pushes through the central core of the engine, where the air is compressed, mixed with fuel, and ignited. Turbofan engines like the Rolls-Royce Tay are not as powerful as turbojets, but they are quieter and more efficient. (Microsoft Encarta)

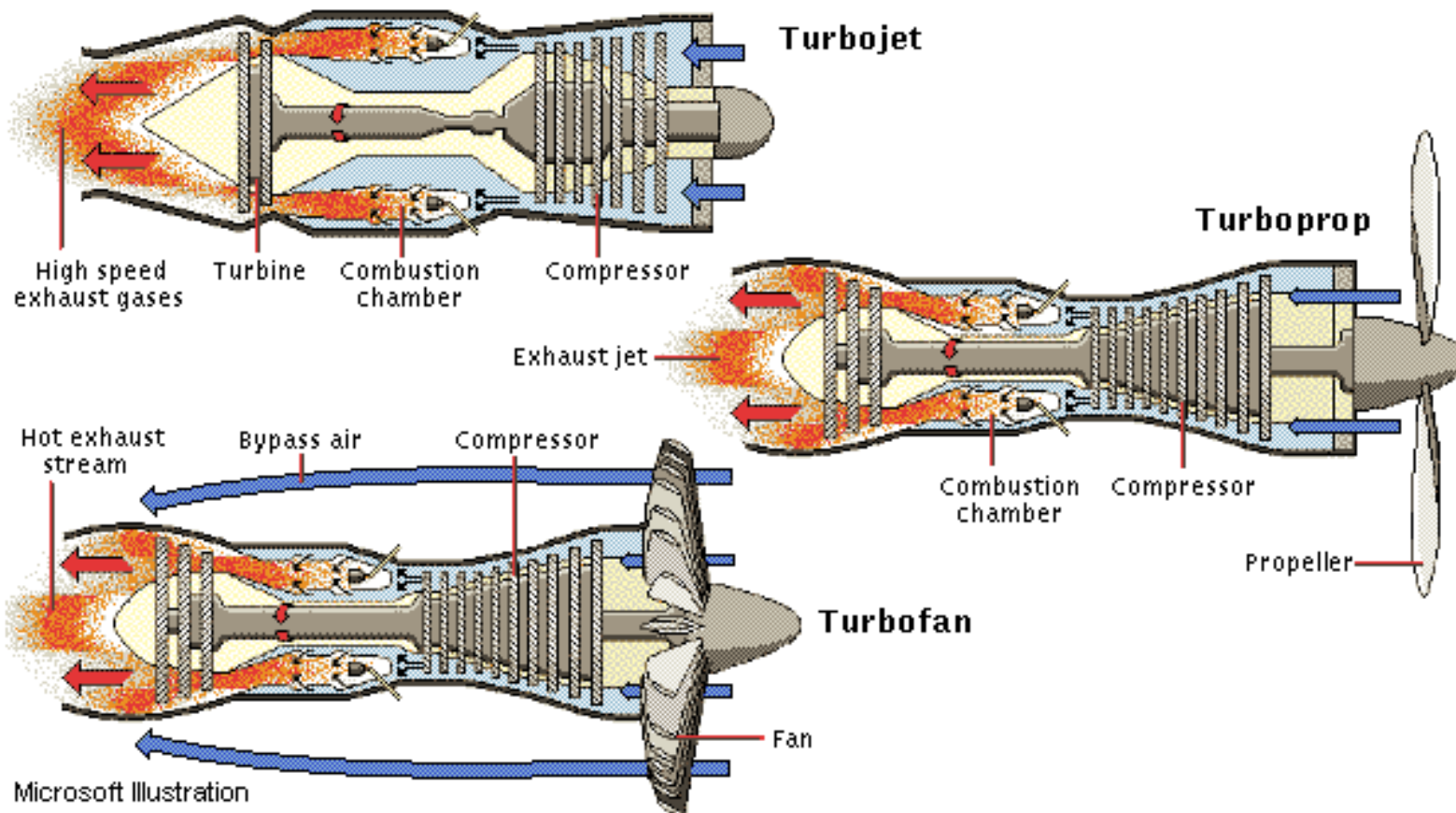

Figure A.2 Jet Engines

The three most common types of jet engines are the turbojet, turboprop, and turbofan. Air entering a turbojet engine is compressed and passed into a combustion chamber to be oxidized. Energy produced by the burning fuel spins the turbine that drives the compressor, creating an effective power cycle. Turboprop engines are driven almost entirely by a propeller mounted in front of the engine, deriving only 10 percent of their thrust from the exhaust jet. Turbofans combine the hot air jet with bypassed air from a fan, also driven by the turbine. The use of bypass air creates a quieter engine with greater boost at low speeds, making it a popular choice for commercial airplanes. (Microsoft Encarta 1998).

APPENDIX C. GLOSSARY OF USAF TERMINOLOGY

Air Force Base – a base supports Air Force units and consists of landing strips and all components of related facilities for which the Air Force has operating responsibility.

ACC – Air Combat Command.

AETC – Air Training Command.

AFMC – Air Force Material Command.

AFSPC – Air Force Space Command.

AGL – above ground level.

AMC – Air Mobility Command.

BASH Team – the mission of the USAF Bird Aircraft Strike Hazard (BASH) Team is to prevent bird and other wildlife related aircraft mishaps.

Bird strike rate – number of bird strikes per 10,000 aircraft movements.

Bomber aircraft – these aircraft are designed to carry large air-to-ground-weapons loads and either penetrate or avoid enemy air defenses in order to deliver those weapons. Some well-known bombers include the Boeing B-52, the Rockwell B-1, and the Northrop-Grumman B-2 stealth bomber. Bombers like the B-52 are designed to fly fast at low altitudes, following the terrain, in order to fly under enemy radar defenses, while others, such as the B-2, may use sophisticated radar-defeating technologies to fly virtually unobserved.

Canopy – the transparent portion of an enclosure, exclusive of the windshield. The canopy system includes the framing and edge attachment structure.

Cargo aircraft – these aircraft are capable of carrying enormous tanks, armored personnel carriers, artillery pieces, and even smaller aircraft. Cargo planes such as the giant Lockheed C-5B and McDonnell Douglas C-17 were designed expressly for such roles. Some cargo planes can serve a dual role as aerial gas stations, refueling different types of military airplanes while in flight. Such tankers include the Boeing KC-135 and McDonnell Douglas KC-10.

Fighter aircraft – these aircraft are designed to engage in air combat with other airplanes, in either defensive or offensive situations. Since the 1950s many fighters have been capable of Mach 2+ flight (a Mach number represents the ratio of the speed of an airplane to the speed of sound as it travels through air). Some fighters have a ground-attack role as well, and are designed to carry both air-to-air weapons, such as missiles, and air-to-ground weapons, such as bombs. Fighters include such aircraft such as the McDonnell Douglas F-15 Eagle and the Lockheed-Martin F-16 Falcon.

Fuselage – the fuselage is the main cabin, or body of the aircraft. Generally the fuselage has a cockpit section at the front end, where the pilot controls the airplane, and a cabin section. The cabin section may be designed to carry passengers, cargo, or both. In a military fighter plane, the fuselage may house the engines, fuel, electronics, and some weapons.

Greenwich Mean Time – the mean solar time for the meridian at Greenwich, England, used as a basis for calculating time throughout the world.

Hours flown – the airborne hours computed from the moment an aircraft leaves the ground until it touches ground again.

IFR – instrument flight rule. A set of rules governing the conduct of flight under instrument meteorological conditions.

KIAS – knots indicated air speed.

Landing gear - all airplanes must have some type of landing gear. Modern military aircraft employ brakes, wheels, and tires designed specifically for the demands of flight.

Low-level operations - training missions that require aircraft to fly low and fast using terrain masking techniques to practice radar avoidance.

MAJCOM – Major Command.

Movement – a take-off, landing, touch and go, or missed approach.

MASMS - the Military Airspace Management System (MASMS) is an on-line database for scheduling and de-conflicting military airspace of all types. It is a classic example of centralized management of scarce resources (airspace) with decentralized execution, and is the only system of this scale in all of DOD. MASMS is available through computer connection 24-hours per day, 365 days per year. MASMS is run by Det 1 HQ ACC/DOR at Offutt AFB, NE.

PACAF – Pacific Air Forces.

Range – an area equipped for practice in shooting at targets.

Reconnaissance aircraft – observation aircraft. With the advent of the Lockheed U-2 spy plane in the 1950s, observation airplanes were developed solely for highly specialized missions. The ultimate spy plane is Lockheed's SR-71, a two-seat airplane that uses specialized engines and fuel to reach altitudes greater than 25,000 m. (80,000 ft.) and speeds well over Mach 3.

Restricted operations area – airspace of defined dimensions, designated by the airspace control authority, in response to specific operational situations/requirements within which the movement of one or more airspace users is restricted.

Tail - most aircraft have a tail assembly attached to the rear of the fuselage, consisting of vertical and horizontal stabilizers, a rudder, and elevators.

Trainer aircraft - all military pilots go through rigorous training and education programs using military training airplanes to prepare them to fly the high-performance aircraft of the armed forces. They typically begin the flight training in relatively simple, propeller airplanes and move into basic jets before specializing in a career path involving fighters, bombers, or transports. Some military trainers include the T-3, T-37, and T-38.

Transparencies – any portion of the aircraft allowing clear vision while protecting the inside of the aircraft from the surrounding environment.

Turbine engines – Turbine or jet engines operate on the principle of Newton's third law of motion, which states that for every action, there is an opposite but equal reaction. A jet sucks air into the front, squeezes the air by pulling it through a series of spinning compressors, mixes it with fuel, and ignites the fuel, which then explodes rearward with great force out through the exhaust nozzle. This great rearward force is balanced with an equal force that pushes the jet engine, and the airplane attached to it, forward. The three most common types of jet engines are the turbojet, turboprop, and turbofan.

Turbofan engines - turbofans combine the hot air jet with bypassed air from a fan, driven by the turbine. The use of bypass air creates a quieter engine with greater boost at low speeds, making it a popular choice for commercial aircraft.

Turbojet engines - air entering a turbojet engine is compressed and passed into a combustion chamber to be oxidized. Energy produced by the burning fuel spins the turbine that drives the compressor, creating an effective power cycle.

Turboprop engines – these engines are driven almost entirely by a propeller mounted in front of the engine, deriving only 10 percent of their thrust from the exhaust jet.

VFR – visual flight rule, rules that govern the procedures for conducting flight under visual conditions (VMC). The term also is used in the United States to indicate weather conditions that are equal to or greater than minimum VFR requirements. In addition, it is used by pilots and controllers to indicate a type of flight plan.

Windscreen – the windscreen is the areas of an aircraft transparency used for forward vision in taking off, flying, and landing; usually made of laminated glass or plastic. Also known as a windshield. In aircraft where the windscreen and canopy are inseparable, windscreen or windshield is implied when the term canopy is used.

Windshield – the windshield is a part or surface area of a transparent material ahead of the cockpit or in front of the pilot's cabin affording protection from the wind and allowing forward vision.

Wings – wings provide the lift that enable aircraft to fly.

VITA

Christine Atkins Tedrow was born in Richmond, Virginia to Mr. Roger L. Atkins and Mrs. Barbara J. Kagey on June 26, 1970. She grew up in Roanoke, Virginia where she attended and graduated from William Byrd High School in 1988. She then attended the United States Air Force (USAF) Academy in Colorado Springs, Colorado. Christine graduated from the Academy in May 1992 with a Bachelor of Science in Biology and a minor in Russian and was commissioned in the United States Air Force as a second lieutenant.

Her first assignment in the USAF was to Wright-Patterson AFB, Ohio where she was a Chemical/Biological Warfare (CBW) Analyst at the National Air Intelligence Center (NAIC). Christine was responsible for analyzing CBW intelligence data and producing threat assessment reports.

Christine's second assignment in the USAF was to Kirtland AFB, NM. From November 1994 to August 1997 she was a Wildlife Ecologist on the USAF Bird Aircraft Strike Hazard (BASH) Team at the Air Force Safety Center. As a member of the BASH Team, Christine provided guidance and on-site technical assistance to bases in reducing bird strike hazards on airfields and weapons ranges. In addition, she was responsible for collecting and managing bird strike data. While on the BASH Team, Christine was promoted to the rank of Captain in May 1996 and married Captain Mark Alexis Tedrow in May 1997.

From August 1997 to December 1998 Christine attended Virginia Tech and obtained a Master of Science in Wildlife Science. Beginning in January 1999, she will be assigned to the USAF Academy for three years as an Instructor of Biology.