

173
84

Conceptual Manipulator Design For Limited Access Workspaces

by

Steven B. Shooter

Thesis submitted to the Faculty of the
Virginia Polytechnic Institute and State University
in partial fulfillment of the requirements for the degree of

MASTER OF SCIENCE

in

Mechanical Engineering

APPROVED:

Charles F. Reinholtz, Chairman

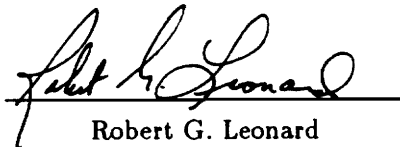
Robert G. Leonard

Harry H. Robertshaw

December, 1990
Blacksburg, Virginia

c.2

LD

5655

V855

1990

S547

C.2

Conceptual Manipulator Design For Limited Access Workspaces

by

Steven Bryan Shooter

Committee Chairman: Charles F. Reinholtz
Mechanical Engineering

Abstract

Robotic manipulators for limited access workspaces, or LAWS robots, must operate in unalterable, confined environments accessed through constrictive portals. The characteristics of these robots distinguish them from the currently accepted classes of industrial robots and field robots and evoke a particular design strategy. Special consideration must be given to the ability of the LAWS manipulator to service a target workspace while constrained within the boundaries of a confined environment. The limited access to the environment also imposes restrictions on the size and shape of the manipulator. This thesis characterizes LAWS robots and develops a strategy for designing them. This strategy is then applied to the design of a LAWS robot for steam generator maintenance in nuclear power plants. The calibration of a LAWS robot is also discussed. Applications for robots that can operate in limited access workspaces exist in the nuclear, construction, mining, and medical industries, among others. This thesis provides, for the first time, a specific set of guidelines to aid in the design of such robots.

Acknowledgements

I would like to express my sincere appreciation to the chairman of my advisory committee, Prof. Charles F. Reinholtz. His suggestions and insights have proven invaluable. His positive outlook and enthusiasm have enlightened both my professional and personal ambitions. His sincere devotion to his profession and to those of us who depend on him has set an example which I hope to one day emulate.

I must also extend my thanks to Prof. Sanjay G. Dhande, whose ideas on conceptual design methods contributed greatly to this work. I hope that all will continue to go well for him whether it be in India or in the U.S.

I wish to thank the other members of my advisory committee, Prof. Robert G. Leonard and Prof. Harry H. Robertshaw for all of their helpful comments.

I am deeply grateful to my parents, William and Barbara Shooter. Their support and encouragement throughout my life have enabled me to accomplish what I have. My father has shown me the value of education and inspired me to pursue an academic career.

Of course, I must express my most heartfelt gratitude to my fiance, Catherine. Her unwavering support made all of the late nights bearable.

Contents

1	Introduction	1
1.1	Classification of Robots	1
1.2	Examples of LAWS Robots	4
1.3	Review of Literature	10
1.3.1	Brief History of Robot Design	10
1.3.2	Robot Design Considerations	11
1.3.3	Calibration	12
2	Conceptual Design Methodologies	14
2.1	Seven Stages of Engineering Design	14
2.2	Development of the Design Method	17
2.2.1	Clarifying Objectives	18
2.2.2	Creative Methods	18
2.2.3	Evaluation and Selection	19
2.3	Other Work on Design Methodology	20
3	Issues In Designing LAWS Robots	22
3.1	Formulation of The Problem	22
3.2	Classes of LAWS Manipulators	24
3.3	Selection	26

3.4	Modeling and Analysis Issues	28
3.5	Mezzanine Base Design	34
4	Design of a LAWS Robot	35
4.1	Confrontation	35
4.2	Formulation of the Problem	36
4.3	Development of Concepts and Selection	40
4.3.1	Concept Evaluation	40
4.3.2	Selection	48
4.4	Synthesis	49
4.5	Analyzable Model	51
4.5.1	Coordinate Frames	51
4.5.2	Workspace Model	55
4.5.3	Manipulator Model	56
4.6	Experiment, Analysis, and Optimization	66
4.6.1	Forward Kinematic Analysis	66
4.6.2	Clearance Determination	67
4.6.3	LAWS Analysis Program	69
4.7	Presentation	71
5	Calibration of a LAWS Robot	73
5.1	Intrinsic Calibration	74
5.1.1	External Intrinsic Calibration	76
5.1.2	Internal Intrinsic Calibration	77
5.2	Extrinsic Calibration	81
5.2.1	Modeling	81

5.2.2	Finding β , γ , and ${}^B M_Z$	84
5.2.3	Finding α , ${}^B M_X$, and ${}^B M_Y$	87
6	Conclusions and Recommendations	90

List of Figures

1.1	Schilling Manipulator	5
1.2	ROGER by Babcock and Wilcox	6
1.3	Spine robot	7
1.4	Fiberoptic Sigmoidoscope	9
2.1	The Seven Stages of Engineering Design (<i>Sandor, 1964</i>)	16
3.1	A - Environment Workspace; B - Target Workspace; C - Conventional Workspace; D - Limited Access Workspace	23
3.2	Examples Showing Each of the Five Classes of LAWS Robots	27
3.3	Planar, Two link, Two Degree-of-freedom Manipulator	29
3.4	Workspace Constrained By Environment	31
3.5	Limited Attainable Workspace	32
3.6	Alternative Base Location	33
4.1	Quartersphere Environment or "Bowl"	37
4.2	Class I: Pillar or Mast-Based Manipulators	41
4.3	Class II: Interior Supported Mezzanine-Based Manipulators	42
4.4	Class III: Portal or Exterior Mounted Mezzanine-Based Manipulators	43
4.5	Class IV: Long Chain, Exterior Mounted Manipulators	44
4.6	Class V: Field-Robot Type Manipulators	45

4.7	Original Manipulator Concept	50
4.8	Modified Manipulator Concept With Offset Link	52
4.9	Manipulator Design Shown in Collapsed Position	53
4.10	Environment and Manipulator Coordinate Systems	54
4.11	Manipulator Illustrating Definitions of Terms	57
4.12	Top View of the Bowl Indicating Two Possible θ_1 Values	59
4.13	Eight Possible Kinematic Solutions	60
4.14	Planar View of Manipulator	63
4.15	Clearances (Note: dashed arcs in figure indicate bowl radius at that height)	68
4.16	Prototype of The LAWS Manipulator	72
5.1	Kinematic Model of Manipulator Showing Attached Coordinate Axes	75
5.2	Manipulator Configuration For Intrinsic Calibration	78
5.3	Kinematic Representation of the Calibration Configuration	79
5.4	Environment and Manipulator Coordinate Systems Prior to Calibration	82
5.5	Correlation Between Coordinate Frame Transformations	83

List of Tables

1.1	Comparison of Robot System Attributes	3
4.1	Screening Criteria	47
5.1	Denavit-Hartenburg Parameters for the Manipulator	76

Chapter 1

Introduction

In general, robotic systems have been classified either as industrial robots or as field robots. In this thesis, another class of robotic systems is identified that does not seem to belong in either of these categories. These systems are termed as Limited Access Workspace robots or LAWS robots, in short. The LAWS robots have distinctly different attributes and require a different and particular approach for their conceptual design, modeling and analysis. The objective here is to introduce the concept of LAWS robots, to discuss how LAWS robots can be characterized and compared with respect to field and industrial robots, and to present a methodology of design, modeling and analysis of LAWS robots. This will then be followed with the detailed design procedure of a LAWS robot. The issue of calibration of a LAWS robot will also be addressed.

1.1 Classification of Robots

The Robotics Industries Association (RIA) defines an industrial robot as a reprogrammable multifunctional manipulator designed to move materials, parts, tools, or special devices through variable motions for the performance of a variety of tasks (*Groover, 1986*). Industrial robots are designed for use in a controlled environment.

They are typically installed in a precise location in reach of all materials and components necessary to perform their desired functions with maximum efficiency. Often the work cell is designed to meet the needs of the robot. Because the industrial robot is set in place and unmoved, little consideration is given to design for portability or ease of installation. The industrial robot can generally be viewed directly by an operator who is capable of accessing all parts of the assembly. The industrial robot undergoes intrinsic and extrinsic calibration in a controlled environment. Intrinsic calibration describes the procedure that corrects for errors in the manipulator construction. Extrinsic calibration identifies the position of the robot's base coordinate system with respect to the defined global coordinate system.

Field robots work in environments as they are encountered; the environment cannot be altered to accommodate automation. As Whittaker describes in "Field Robotics: A National Challenge, A National Opportunity" (1990), "Field robots are often mobile. They incorporate numerous motions, impart large working forces, and compensate for terrain and their own internal compliance. They require task-appropriate sensing and tooling. Field robots cannot fully exploit stationary resources as do factory robots, hence they incorporate significant onboard infrastructure of power, computing and telemetry". The operations of a field robot may be viewed directly or via camera. The robot may or may not be accessible by an operator, depending on the environment of operation. The field robot may undergo intrinsic calibration before operation, but must interact dynamically with its environment.

Limited Access Workspace (LAWS) robots must function in a pre-existing, unalterable workspace and environment. They must be capable of passing through a small opening and functioning in a larger space. LAWS robots must typically be

Table 1.1: Comparison of Robot System Attributes

Attribute	Manipulator Type		
	Industrial	Field	LAWS
Installation	One time	Dynamic	Updated at every worksite
Workspace Environment	Designed Environment	Dynamic Environment	Defined, existing Environment
Viewing	Direct	Direct or Indirect	Indirect
Accessibility	Yes	May or may not be	Mostly not
Assembly	Enabled Once	Enabled once or at site	Enabled/disabled at each site
Transport Device	Not Required	Mobility	Required to enter environment
Calibration	Intrinsic and extrinsic Set and Controlled	Intrinsic No extrinsic Dynamic	Intrinsic - set Extrinsic - must be reset at each worksite

portable for transportation to difficult-to-reach worksites. They must be installed to perform their task and then removed. Installation of the manipulator may require a transport device. Because of the enclosed environment, operation of a LAWS robot generally cannot be viewed directly. The LAWS robot is most often inaccessible by an operator while in operation. The LAWS robot undergoes intrinsic calibration off-line, and it may be recalibrated upon installation. Extrinsic calibration must be performed after installation and at any new base location.

The characteristics of Industrial, Field and LAWS robot systems are summarized in Table 1.1.

1.2 Examples of LAWS Robots

LAWS robots present a wide range of applications. In the nuclear industry LAWS robots are utilized for inspection and maintenance in the reactor. The confinement of the nuclear reactor and the hazard of radiation require a manipulator with the ability to enter the reactor through a hole in the casing and extend to service all points within the vessel. Schilling Development, Inc. of Davis, California developed a manipulator that was used at the ATUCHA 1 nuclear power plant in Argentina for cleanup of a reactor vessel. Figure 1.1 is a concept illustration depicting the extraction of debris from the floor of the radioactive vessel at the ATUCHA 1 nuclear station.

LAWS robots are also used for inspection and repair of steam generators in nuclear power plants. The manipulator must fit through a 406 mm manway hole and must be capable of movements through a 1520 mm radius to any of up to 15,000 tube locations. Figure 1.2 shows the ROGER (Remotely Operated Generator Examination and Repair) manipulator developed by Babcock and Wilcox.

LAWS robots have been developed for manufacturing applications. The Spine robot is shown in Figure 1.3 spray painting the interior of an automobile body. The flexible arm consists of a number of ovoid discs that are held together by two pairs of tensional cables. The cables are attached to hydraulic cylinders that create the tension to enable the movement of the arm. The long reach and maneuverability of this manipulator allow it to work in areas that are inaccessible to ordinary industrial robots.

LAWS robots have many other far-reaching applications, including medicine. Instruments have been developed that can pass through a body orifice to reach areas

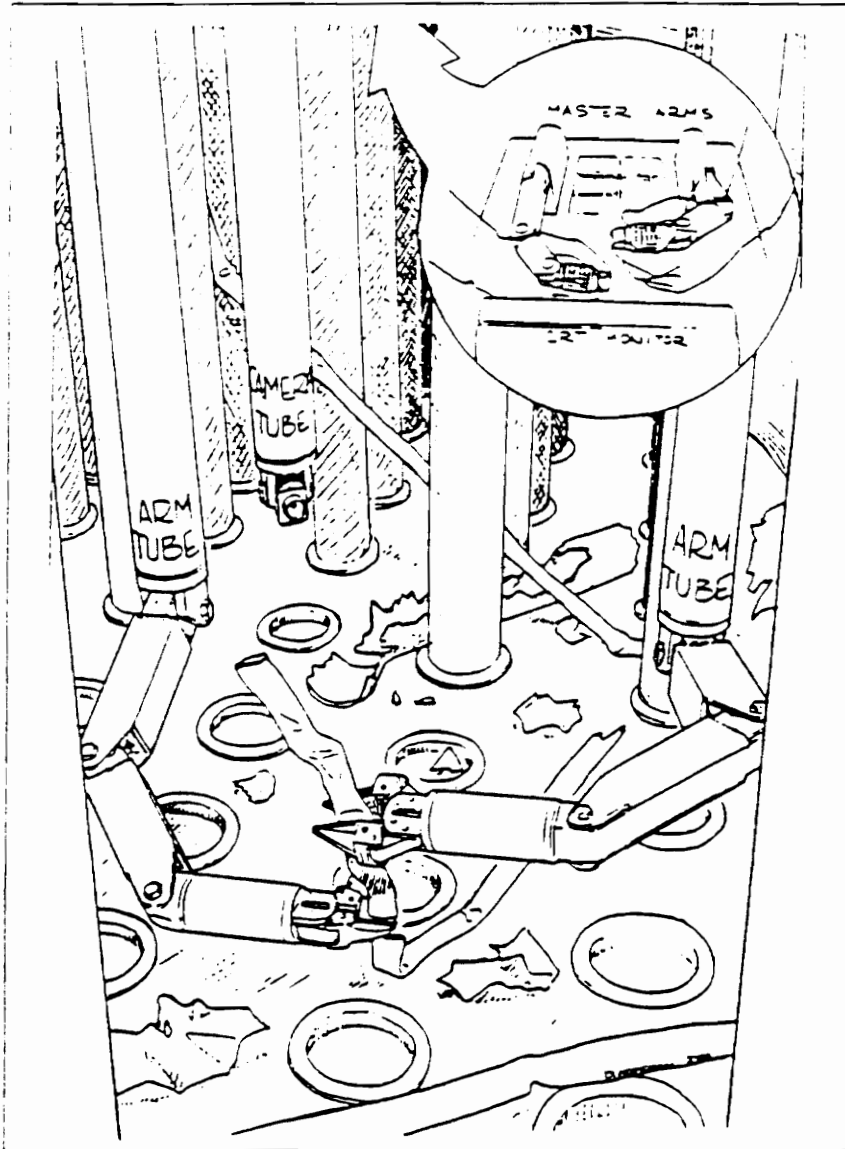

Figure 1.1: Schilling Manipulator

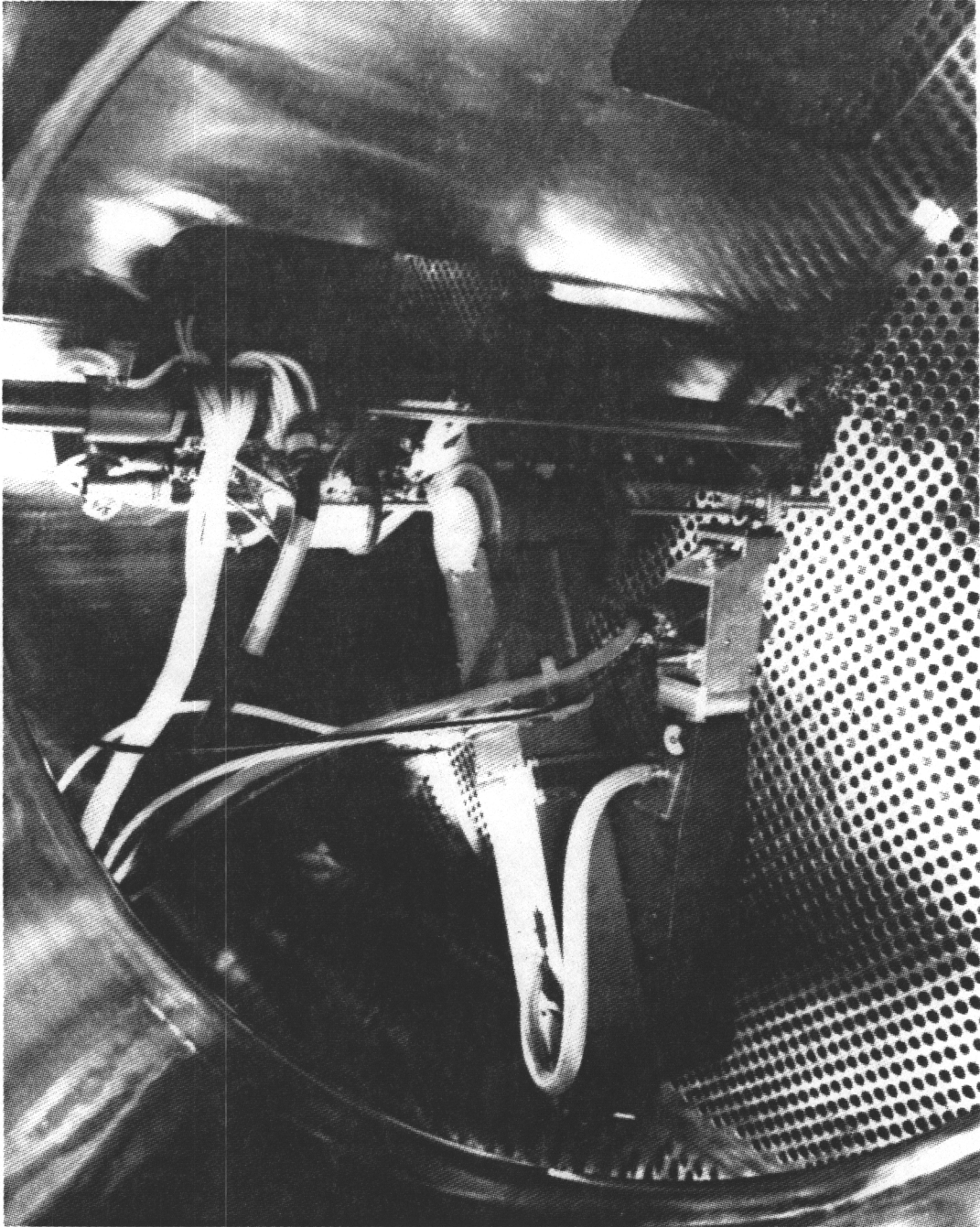

Figure 1.2: ROGER by Babcock and Wilcox

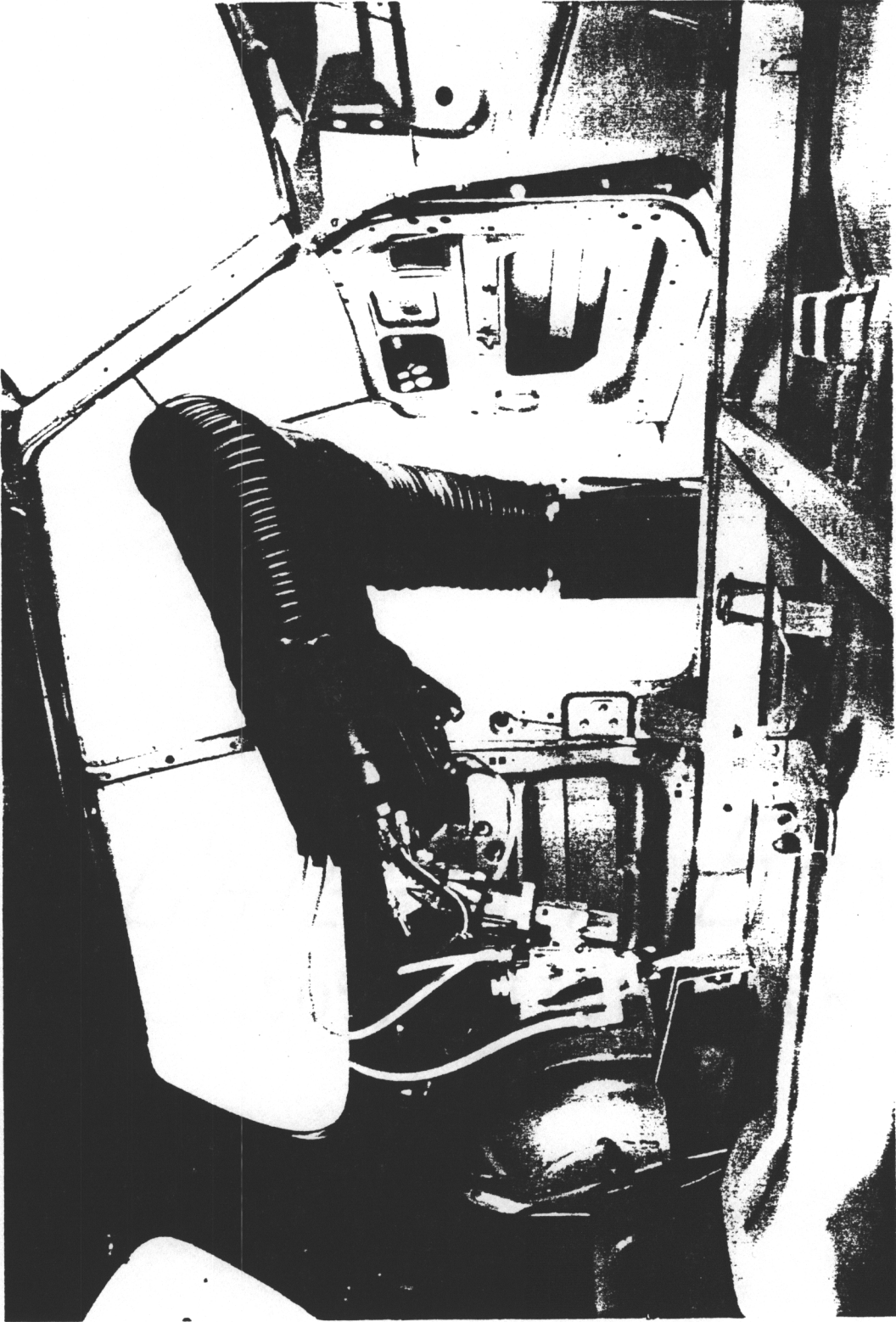

Figure 1.3: Spine robot

which had previously only been attainable through surgery. While endoscopes use similar optical structures, they vary widely in length, tool diameter and maneuverability. The technology of the endoscope has been advanced to include an air or water outlet, and suction or forceps channels as well as electrosurgical units. Presently, the tip of the endoscopes are crudely operated by manipulating control knobs. Figure 1.4 shows a close-up of a fiberoptic sigmoidoscope with biopsy forceps. The next level of development of such instrumentation may be achieved with LAWS robots.

LAWS robots have numerous applications in the construction and mining industry. Groover sites in "A Survey of Robotics Technology in Construction" (1989) that additional capabilities to an industrial robot would be required for construction applications. "One is the capability to operate at different locations of the construction site. To achieve this capability, the construction robot would have to possess either: 1) a larger work volume or 2) mobility". The applications Groover describes require the capabilities of a LAWS robot to reach through openings to larger workspaces such as surveying and support emplacement. LAWS robots can be employed for similar operations in mining or for the extraction of minerals.

LAWS robots may be employed in any situation where the manipulator must pass through a portal to service an existing workspace. Other potential applications range from the examination of the internal operations of an engine to ship and plane loading. LAWS robots can be used for other hazardous service jobs. For example, insect and pest removal requires the servicemen to operate in tight crawlspaces and spray chemicals that produce noxious fumes.

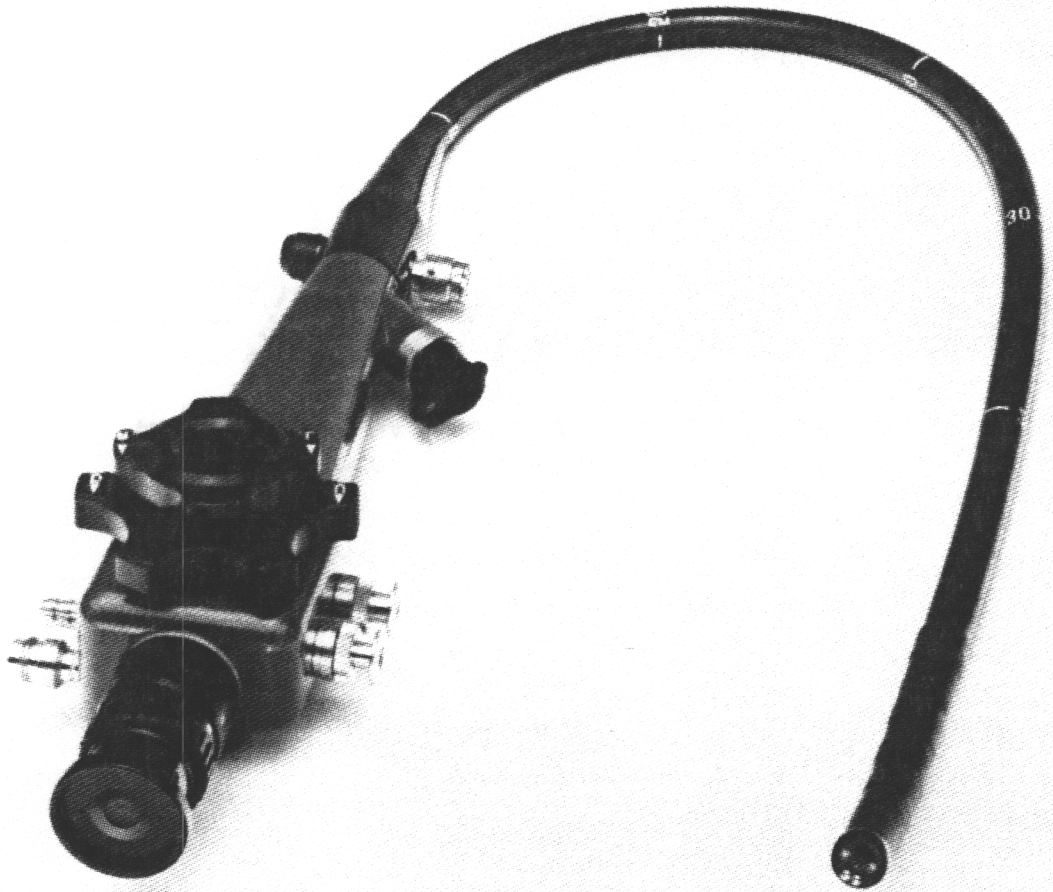

Figure 1.4: Fiberoptic Sigmoidoscope

1.3 Review of Literature

The material within this thesis relies heavily on the fundamentals of kinematics and robotics. This literature review will not contain references to texts which contain these fundamental concepts. Instead, these texts will be referenced within the body of the thesis. This literature review will present a brief history of robot design leading to recent developments in service robots and robots for unstructured environments followed by robot design considerations. Literature referring to calibration of robots will also be presented.

1.3.1 Brief History of Robot Design

Joseph Engelberger, generally considered the father of industrial robotics, recognized the potential for programmable machinery in the early 1950's. He founded the first robotics company, Unimation, Inc. In 1959 General Motors was the first to install a test model Unimate in its Turnstead die-casting plant. Dependence on the use of computation has linked the development of robotics technology to the development of computers. Limitations of computing power restricted the applications of robots to the repetitive tasks and structured environments of production. Much of the early research conducted in robotics focused on the use of serially-connected manipulators for manufacturing environments. The rapid growth in computing technology and the development of the microcomputer created greater capabilities for robots which prompted greater interest by industry (*Asimov, 1985*).

The advances in robotic technology prompted researchers and designers to explore applications for robots outside of the manufacturing environment. Robots have been developed to replace humans for menial or redundant tasks in various facets of the service industry. Evans and Krishnamurthy (*1989*) describe a robot designed to

aid nurses in hospitals by relieving them of routine fetch and carry tasks. Another robot was designed for rehabilitation of stroke patients through movement pattern therapy (*Erlandson, 1989*). Wiercienski and Leek (*1989*) discuss the development of robots used to clean the undersides of subway cars. A robot has also been designed to perform asbestos removal (*Sullivan, 1989*).

Considerable effort has been focused on the area of mobile robots. Waldron and McGhee (*1986*) have designed and built a six legged adaptive suspension vehicle. A group lead by Raibert at Carnegie Mellon University have built and experimented with a one-legged hopping machine (*Raibert, Brown, and Cepponis, 1984*). Hirose (*1984*) has constructed a four-legged mobile robot which concentrated on energy efficiency. Burgos, Dhande, Reinholtz and Stulce (*1990*) at Virginia Tech have developed the concept of a crawling machine based on an actuated multibody structure with passive legs.

Although utilizing robots for unstructured environments is in its infancy, robots have been employed in such diverse applications as underwater operations (*Yuh, 1989*), construction (*Groover, 1989*), and war (*Shaker, 1989*). In an article in *Business Week*, (*1990*), Miles described several uses for robots in hazardous and unstructured environments. He cited examples such as excavation, bomb detection and disposal, space station construction, and space exploration. Whittaker (*1990*) states that “the potential of field robots to perform repetitive and dangerous tasks is virtually untapped.”

1.3.2 Robot Design Considerations

Although no specific articles have been found describing design of LAWS-type manipulator systems, several references provide background information. In “Some

Kinematic Structures for Robot Manipulator Designs”, Earl and Rooney (1983) describe construction of series, parallel and hybrid manipulators. In “Advances in Robot Mechanisms”, Waldron surveyed the latest technology in manipulator configurations, microcomputers, sensing, and control.

Chedmail and Wenger (1989) discuss a situation similar to LAWS applications in “Design and Positioning of a Robot in an Environment With Obstacles Using Optimal Research”. They describe the variables of the design optimization as the position, the orientation and the Denavit-Hartenburg parameters of the robot. The final criterion of design choice is the possibility of the robot to reach a given space called the target space. The methods of optimization closely parallel those of LAWS manipulator design applications.

1.3.3 Calibration

Considerable attention has been given to robot accuracy in recent years. Position accuracy can be improved through calibration and compensation techniques. Several researchers have developed techniques for robot calibration but none of these methods has gained wide acceptance. Roth, Mooring and Ravani (1987) describe the basic issues involved in calibrating robots. They describe the calibration process as four steps: modeling, measurement, identification, and correction. Issues involved with each of these steps are discussed.

Ziegert and Datseris (1988) explain that positioning accuracy depends on two critical issues. “First, the kinematic model used by the controller must reflect the actual robot. Second, ...the location of the robot’s base coordinate system must be accurately known with respect to the user-defined global coordinate system.”

Much of the research in robot calibration concerns the development or determina-

tion of the optimal model description. The traditional model proposed by Denavit and Hartenberg (1955) consists of four parameters. This model has been shown to possess limitations in certain cases. Ziegert and Datsieris critique various modeling methods proposed by other researchers. While they did not determine the optimal model, they did determine that a model containing six independent geometric parameters should be used. Everett and Suryohadiprojo (1988) later prove mathematically that six parameters are required.

While proper model development concerns many researchers, practical constraints in the industrial environment limit the approaches that can be taken. Mooring and Pack (1988) investigate a calibration procedure for calibrating an industrial robot. The procedure involved a combination of redesign and active calibration, and it proved successful in actual industrial application. Many other articles describe calibration methods that have been successful for specific robot types. For example, Tsai, McGee, Cheng and Akeel (1990) from GMFanuc Robotics describe a method for automated calibration of an industrial SCARA robot.

Chapter 2

Conceptual Design Methodologies

Much interest has been generated in developing methodologies for the design process. Esterline, Riley and Erdman (1988) state that “there are nearly as many kind of design theories as there are authors writing on the topic: prescriptions for how to proceed systematically in design, general formal frameworks, applications of formalisms with more modest scope, and empirical theories derived by knowledge engineering methods.” Prompted by developments in artificial intelligence, the National Science Foundation has sparked renewed interest in understanding the design process and formulating new methods to aid the design process. While this is not an exhaustive survey of the field, design theories and research pertinent to the conceptual design of a manipulator are presented.

2.1 Seven Stages of Engineering Design

Sandor’s Seven Stages of Engineering Design (*Sandor, 1964*) is one possible representation of the design process which has been applied in both the academic area and in professional practice. Because Sandor’s model was used to generate the conceptual manipulator design presented in this thesis, it is worthwhile to describe the model in detail. The following information is obtained from his paper. Figure 2.1

shows a flowchart of this method arranged in a Y-shaped structure. The left upper branch of the Y represents the evolution of the design task, while the right upper branch represents the development of the available, applicable engineering background. The junction of the Y represents the merging to generate the design concepts. The leg of the Y is the guideline towards completion of the design, based on the selected concept. Sandor notes that this is not a purely linear process and often involves iterations.

Referring to the flowchart, the confrontation in Stage 1A is the actual encounter of the engineer with a need to take action. Because this usually lacks sufficient information and is indefinite, the engineer must clarify the problem that is to be solved by ascertaining the real need and defining it in concrete terms in Stage 2A. On the right branch of the Y, Stage 1B represents the sources of information available to the engineer, including other people as well as the engineer's own experience base. The applicable areas of these sources of information must be selected in Stage 2B, and the gaps must be filled in with sound assumptions.

In Stage 3 the background developed in Stages 1B and 2B is brought to bear on the problem as it was formulated in Stage 2A. All conceivable designs are developed and represented in schematic skeletal form, drawing on related fields when possible. Here creativity is utilized to generate a large list of design alternatives utilizing any of several methods of brainstorming. Once a list has been developed, the most promising design alternative can be selected considering the requirements and the constraints.

The selected design concept must be given substance in Stage 4 by filling in any blanks with specific parameters using systematic design methods. Computer-aided methods of synthesis have aided this stage considerably, and they have also

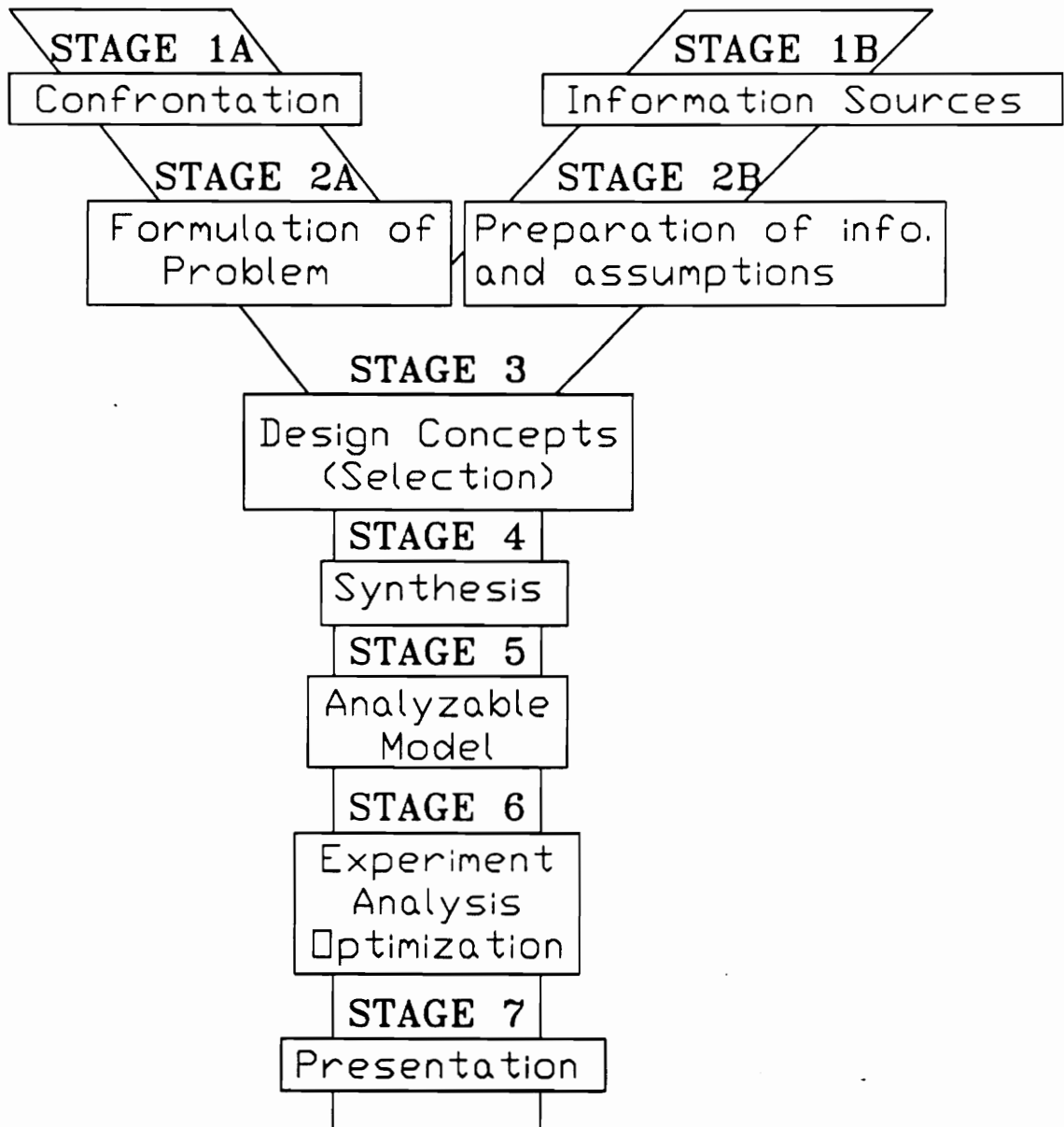

Figure 2.1: The Seven Stages of Engineering Design (*Sandor, 1964*)

benefitted the following Stage 5 where an analyzable model is developed. The model must represent as many of the significant characteristics of the real system as possible to make it amenable to analytic or empirical evaluation.

The objective of Stage 6 is to determine and to improve the expected performance of the design. This stage depends largely on the experience and intuition of the designer, although systematic optimization techniques have been and are being developed. The experiment, analysis and optimization form one integral closed loop in the design process. The results may give rise to iterations involving any or all of the previous stages, including changes of the design concept.

Finally, the design must be prepared for presentation in Stage 7. The design must be accepted by those who will utilize it and those who will realize it. This requires that the presentation be understandable and contain all the necessary details to allow physical implementation.

2.2 Development of the Design Method

Sandor's "Seven Stages of Engineering Design" (1964) presents a flowchart that describes the general process of the design task. The details for undertaking the design process have been explored by numerous authors, some of whom will be presented here. For unification, the development of some of the details on design methods will be related to the flow chart in Figure 2.1.

While the branches of the Y entering Stage 3 are vital to the development of the design, traditional sources have focused on the junction of the Y where the design concepts are developed. The phase of design encompassing Sandor's stages 3, 4, and 5 are what is often termed as the conceptual design. Cross (1989) describes the conceptual design phase as making the greatest demands on the designer, and where

there is the most scope for striking improvements. It is where the most important decisions are taken. Cross describes methods of both clarifying the objectives and enhancing the creative process for conceptual design.

2.2.1 Clarifying Objectives

It is very helpful at all stages of the design process to have a clear idea of the objectives to aid in controlling and managing the design process. To clarify the objectives, Cross proposes the development of an objectives tree. This tree shows the ways in which different objectives are related to each other and the hierarchical pattern of objectives and subobjectives in a diagrammatic form. The development of an objectives tree follows a three-step procedure (*Cross, 1989*).

1. *Prepare a list of design objectives.* These are taken from the design brief from the client, questions to the client, and discussions among the design team. They are a mixture of concrete and abstract aims that the design seeks to achieve.
2. *Order the list into sets of higher and lower order objectives.* These are arranged in levels of importance. Some of the objectives will be identified as a means of achieving certain higher-level objectives.
3. *Draw a diagrammatic tree of the objectives showing hierarchical relationships.* The roots in the tree represent relationships which suggest means of achieving objectives.

2.2.2 Creative Methods

The most widely known creative method is brainstorming. This method allows for the generation of a large number of ideas, some of which will be discarded

later. It is critical to handle the brainstorming session in an orderly manner to allow the most creativity. The group should be chosen with individuals of diverse backgrounds. Each member may contribute an idea and then others may build on it. It is important at this stage not to criticize any of the ideas which can limit the creative process. Even the silliest ideas may be found to have substance later. The pace of the session should be kept active, lulls in discussion can lead to boredom and limit the creative process. When the flow of ideas slows, the session should be brought to a close. It can then be helpful to arrange the ideas into groups of similar characteristics to aid in the discussions for the next session (*Cross, 1989*).

A valuable method for generating ideas can be to enlarge the search space. Often, the problem can be overdefined, which stifles ideas before they can come to fruition. By removing some of the constraints to allow more open flow, and then determining ways to meet the requirements later, the base of ideas can often be expanded.

2.2.3 Evaluation and Selection

Once a variety of designs have been generated, the designer must select the best one. While choices can be made by intuition or arbitrary decision, it is best if the decision can be made with a rational procedure. By reviewing the objectives tree previously developed, two lists of criteria can be developed: screening criteria, and evaluative criteria.

The screening criteria consist of objectives that must be satisfied by the design. These criteria are not weighted and not up for debate. The screening criteria should be written in a fashion which will allow a simple pass/fail answer. For example, a screening criteria may be based on size: The designed assembly must be able to fit in a 1' x 1' x 1' box. All of the designs would then be checked for the ability to fit

in this box. Those designs that do not meet this criteria are **failed**. Upon review of the designs' performance with the screening criteria, it may be found that some of the designs only require slight modifications to pass. This can be an iterative process. The designs that pass the screening criteria then move on to be judged under the evaluative criteria.

The evaluative criteria consist of objectives that are favorable but not critical. Several methods exist for developing the evaluation scheme. One such method is that of weighted objectives. The objectives should be listed in rank order. Then relative weights should be assigned to the objectives. Performance parameters should then be developed for each of the objectives. By assigning scores to each design based on the performance of the objectives and then multiplying by the weighted value, the designs can be compared numerically. While the best alternative may have the highest sum value, comparison and discussion of the performance profiles may be a better design aid.

Once a design concept has been selected, the concept can be refined to develop an analyzable model. If the concept is then found unacceptable after a more detailed analysis, it may be possible to incorporate some of the favorable characteristics of the other designs which did not rate well overall.

2.3 Other Work on Design Methodology

Some research on the process of conceptual design of particular interest was presented by M.B. Waldron, K.J. Waldron and L.T. Herren in "Empirical Study on Generation of Constraints Which Direct Design Decisions in Conceptual Mechanical Design". They investigated the way in which expert designers look at a design and initially attempt to proceed with the design. The paper focuses on two designers

as they develop the conceptual design of a manipulator.

While using this example adds insight to the process of designing a manipulator, the authors discuss several interesting facets of conceptual design. The authors differentiate between the process decisions of the designer which are of the type *what to do next* and the design decisions which may be of the type *to accept, evaluate, verify, etc.* They also discuss two types of design constraints that they call 1) rigid, primary or non-negotiable which must hold and 2) flexible or negotiable constraints, in which one can find the best alternative. They suggest that rigid constraints assist the designer in coming up with alternatives while flexible constraints help him in selecting or negotiating between choices so as to eliminate all but one. While these constraints relate to the previously mentioned screening criteria and evaluative criteria, the authors suggest that these constraints are of a functional type, aiding in the design procedure.

The authors proposed that the designers initially interpret the design by mapping the specifications into their own design space which consists of experience (skill and knowledge), environment, constraints and actions. The designers also impose cost constraints based on the willingness to invest time and effort in the project.

The design methodologies were presented to provide the background to aid the understanding of the procedure used for designing a LAWS manipulator. With the background of conceptual design developed, it is then important to develop the issues pertaining to designing and implementing a LAWS manipulator.

Chapter 3

Issues In Designing LAWS Robots

Each individual manipulator design problem will have design challenges unique to the particular application. There are, however, several general considerations which arise for LAWS robot design. It is necessary first to recognize the problem as that of a LAWS robot application. Once the problem has been recognized as a LAWS robot application, a series of issues particular to their design should be considered. The following presentation will describe these issues while following the design process guidelines of the “Seven Stages of Engineering Design”.

3.1 Formulation of The Problem

In the first stage, the engineer is confronted with the problem. The overall objective can be stated as: design a robotic system that is capable of entering an enclosed volume through a constrictive portal and reaching all of the required points within the volume. Figure 3.1 shows an existing, unalterable environment workspace with limited access, labeled A. Within the environment workspace is a subspace that the manipulator is required to reach with its end effector. This required workspace, termed the target workspace, is labeled B. The workspace of a conventional manip-

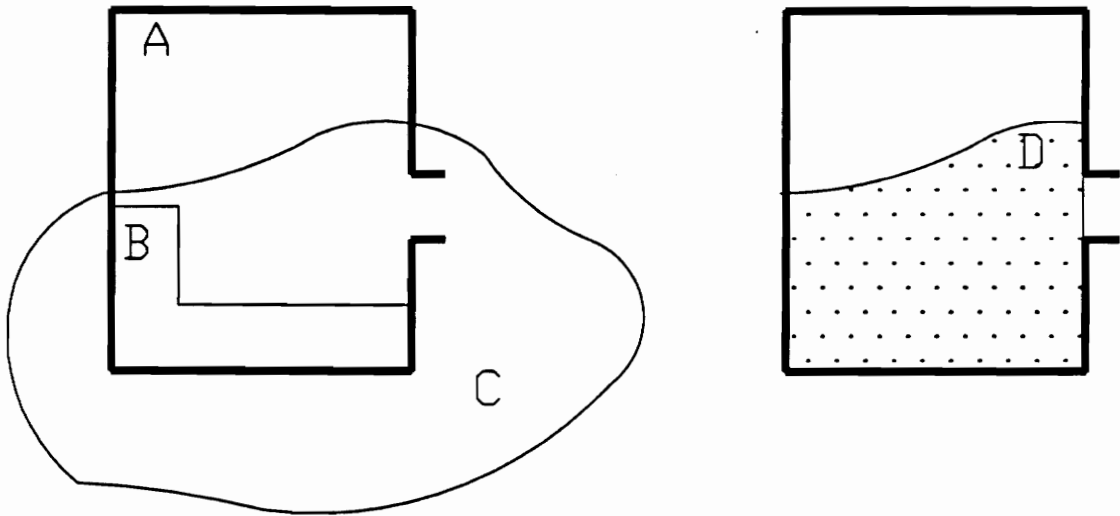

Figure 3.1: A - Environment Workspace; B - Target Workspace; C - Conventional Workspace; D - Limited Access Workspace

ulator is shown as area C. The subspace of the manipulator's workspace C that lies within the environment workspace A is the limited workspace of the manipulator. The limited workspace of the manipulator is labeled D. Note that the area D is the upper bound on the actual workspace.

The problem can now be stated as: design a robot that has its limited workspace D overlapping the target workspace B while considering that the manipulator's operations are restricted by the environment workspace A. Also, consider the need for the manipulator to access the environment workspace through a constrictive portal. Two very important issues that apply to all LAWS robots are the need to develop a means of installation of the manipulator and to develop a means for calibrating the manipulator. Of course, there will be several other design considerations particular to individual applications.

3.2 Classes of LAWS Manipulators

Now that the problem has been formulated, all conceivable design concepts should be developed in skeletal form. Once a variety of conceptual designs have been developed, common characteristics of the designs should become apparent. These common characteristics can be used to classify the manipulators and aid in the selection process. The LAWS robot classes that have been conceptualized through the course of this work are as follows:

Class I: Pillar or Mast-Based Manipulator

These robots are closest to the industrial robot type. The assembly is entered into the work environment and installed internally. Limited access to the workspace may require novel installation procedures. Once the robot is set up, its operation

is similar to that of industrial robots. The difficulty in installing and removing the robot through a limited access may make these robots unattractive in some situations.

Class II: Interior Supported, Mezzanine-Based Manipulator

These robots are best characterized by the presence of an intermediate platform, or mezzanine, that extends into the environment workspace from which the manipulator operates. A support leg or structure is used to brace the mezzanine against the boundary of the environment workspace. These robots may be more attractive than the mast-based robots because the mezzanine provides a means of installation. However, the operator may have to break the plane of the portal to install the mezzanine. Also, the presence of the mezzanine and support leg within the environment boundary limits the possible workspace of the manipulator.

Class III: Portal or Exterior Mounted Mezzanine-Based Manipulator

These robots are characterized by a mezzanine that extends into the environment workspace but does not contact the interior boundary of the environment. These robots are similar to those of class II; however, the environment boundary is not contacted and is therefore free for access by the manipulator.

Class IV: Long Chain, Exterior Mounted Manipulator

These robots are capable of reaching into the environment workspace through the limited access portal and accessing the target workspace. These robots do not require an internal mezzanine base, but may require a large number of joints and actuators to achieve the needed dexterity.

Class V: Field-Robot-Type Manipulator

If the relative size of the portal and the environment workspace are large compared to the robot size, the problem can be characterized as that of a field robot design. For example, a robot that enters a room through a door and polishes the floor would have performed a LAWS objective. The mobility of the robot may become more complicated depending on the environment. Also, the robot must provide the mobility to operate in the environment workspace.

Figure 3.2 illustrates the five classes of robots utilized for the same application.

3.3 Selection

Once the concepts have been categorized, they should be screened to narrow the field of choices. Screening based on a pass/fail system should be employed at this stage. Attributes to consider in the selection process include the ability of the robot to meet the workspace requirements, the ability of the assembly to fit through the portal, reliability, portability, ruggedness, bulkiness, and weight.

Because the designs are only of skeletal form at this point, determination of acceptability may be difficult. However, the designs should be evaluated to the extent possible. After all of the designs have been graded, those designs which were found to be questionable may be developed further to better interpret their ability to meet the requirements. It is important to limit the development of the concept only to the point necessary to allow further evaluation. Also, only those concepts that have been found appealing in several of the other requirements should be developed further.

After the concepts have been narrowed to those that meet the screening criteria, they should be evaluated based on performance with the evaluative criteria. Evaluative criteria may include estimated speed, estimated cost, mode of deployment,

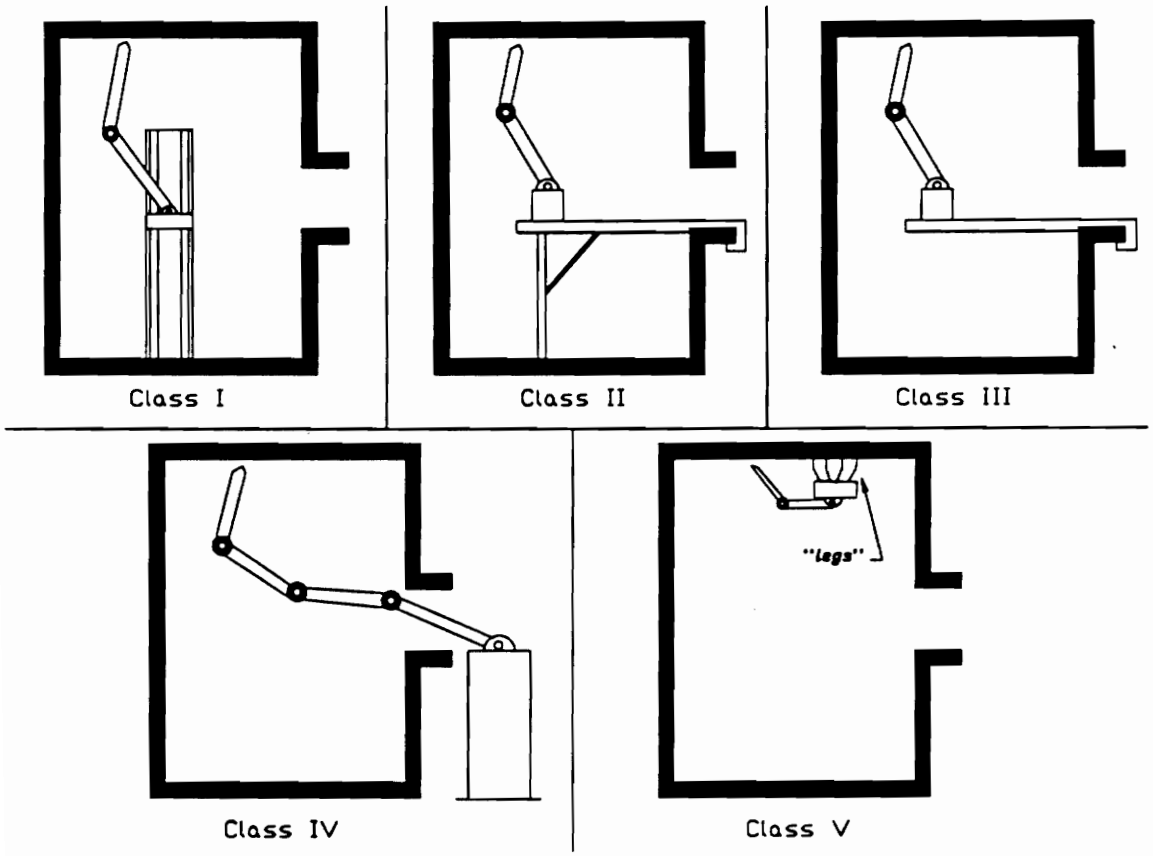

Figure 3.2: Examples Showing Each of the Five Classes of LAWS Robots

and ease of use. It may be found that one of the five classes of LAWS robots may be more appealing than the others. Upon completion of the evaluation, a single design concept should be selected for analysis.

3.4 Modeling and Analysis Issues

Of primary importance is the ability of the robot to meet the workspace requirements. Analysis of this requires the development of a kinematic model of the manipulator. Before beginning the kinematic model, it is important to understand some of the kinematic design issues particular to LAWS robots. Craig (1989) describes workspace as “that volume of space which the end-effector of the manipulator can reach. For a (kinematic) solution to exist, the specified goal point must lie within the workspace.” For a limited access workspace, the designer must consider both the unrestricted workspace of the end-effector, and also consider the effective position of each link of the manipulator in relation to the environment boundary.

The constraint of the environment boundary limits the capability of the manipulator to assemble and reach the target workspace. It is not enough for a solution to exist. The solution must exist with all links constrained to move within the boundary of the environment workspace. The limited access workspace can then be defined as that volume of space which the end-effector can reach with the manipulator constrained by the environment boundary. In some respects, this problem is similar to a manipulator operating in a workspace filled with obstacles.

Consider a planar, two link, two degree-of-freedom manipulator as shown in Figure 3.3. The rotation of the first link about the first joint generates a locus of points at the second joint. The rotation of the second link about the second joint at each of the second joint locations generates the workspace of the manipulator. When the

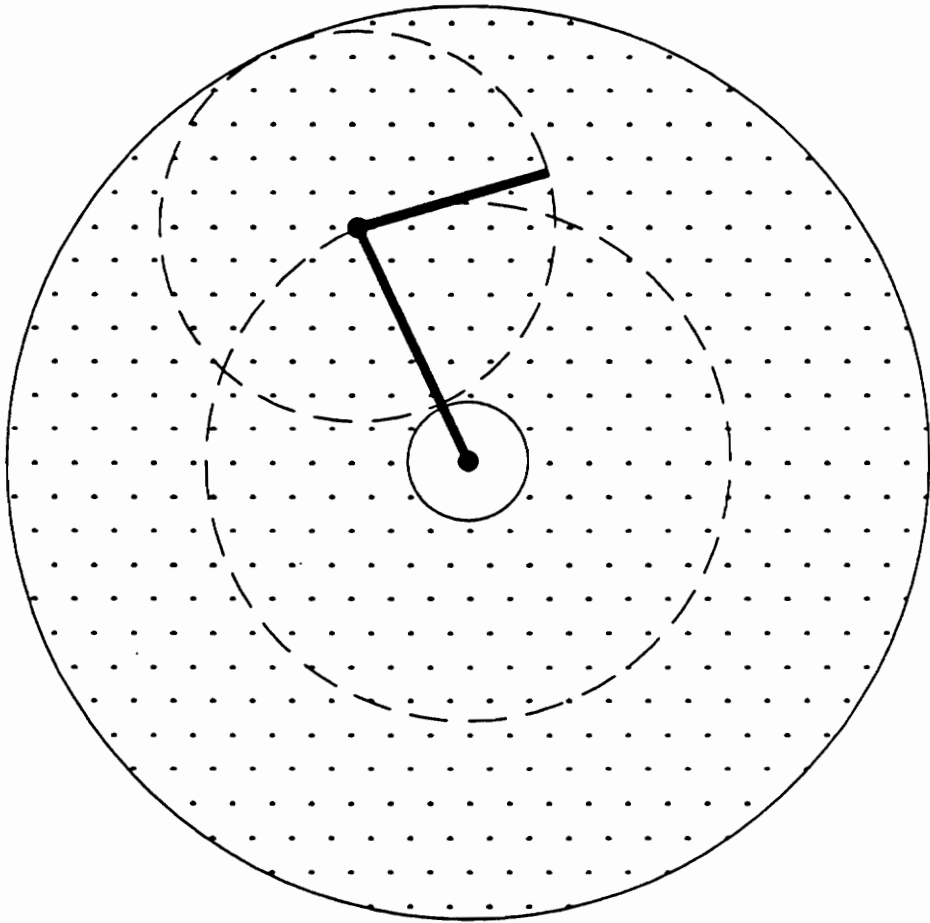

Figure 3.3: Planar, Two link, Two Degree-of-freedom Manipulator

environment area is imposed upon the system, the locus of points for the second joint is reduced. This in turn reduces the workspace of the manipulator. This is illustrated in Figure 3.4.

Solutions of a mathematical model of the manipulator considering the restrictions of the environment workspace would generate the limited access workspace shown in Figure 3.4. However, the generated workspace would represent all possible closures of the manipulator. While it may be possible for the manipulator to assemble at a given point, it may not be possible for the manipulator to attain the required position from the previous position without disassembly. This physical constraint must be considered in the analysis. Because the manipulator in Figure 3.4 cannot physically pass from one closure to another, the attainable workspace is then limited to that shown in Figure 3.5.

By inspecting Figures 3.3,3.4, and 3.5, it is clear that the limited access workspace is dependent not only on the manipulator configuration but also on the placement of the base of the manipulator. Figure 3.6 illustrates that the same manipulator will generate a different limited access workspace when the base is moved. The means of locating the base relates directly to the five general classes of LAWS-type manipulators.

It is also important to develop the idea of clearance for analysis of the model. The clearance of a joint can be described as the minimum distance from the joint to the boundary of the environment workspace. Ideally, the clearance of each joint of the manipulator should be checked for each solution which reaches the target workspace. The minimum requirement for a valid solution is that it have positive values for all clearances at each joint. The designer may wish to impose additional constraints to compensate for physical limitations of the manipulator such as link

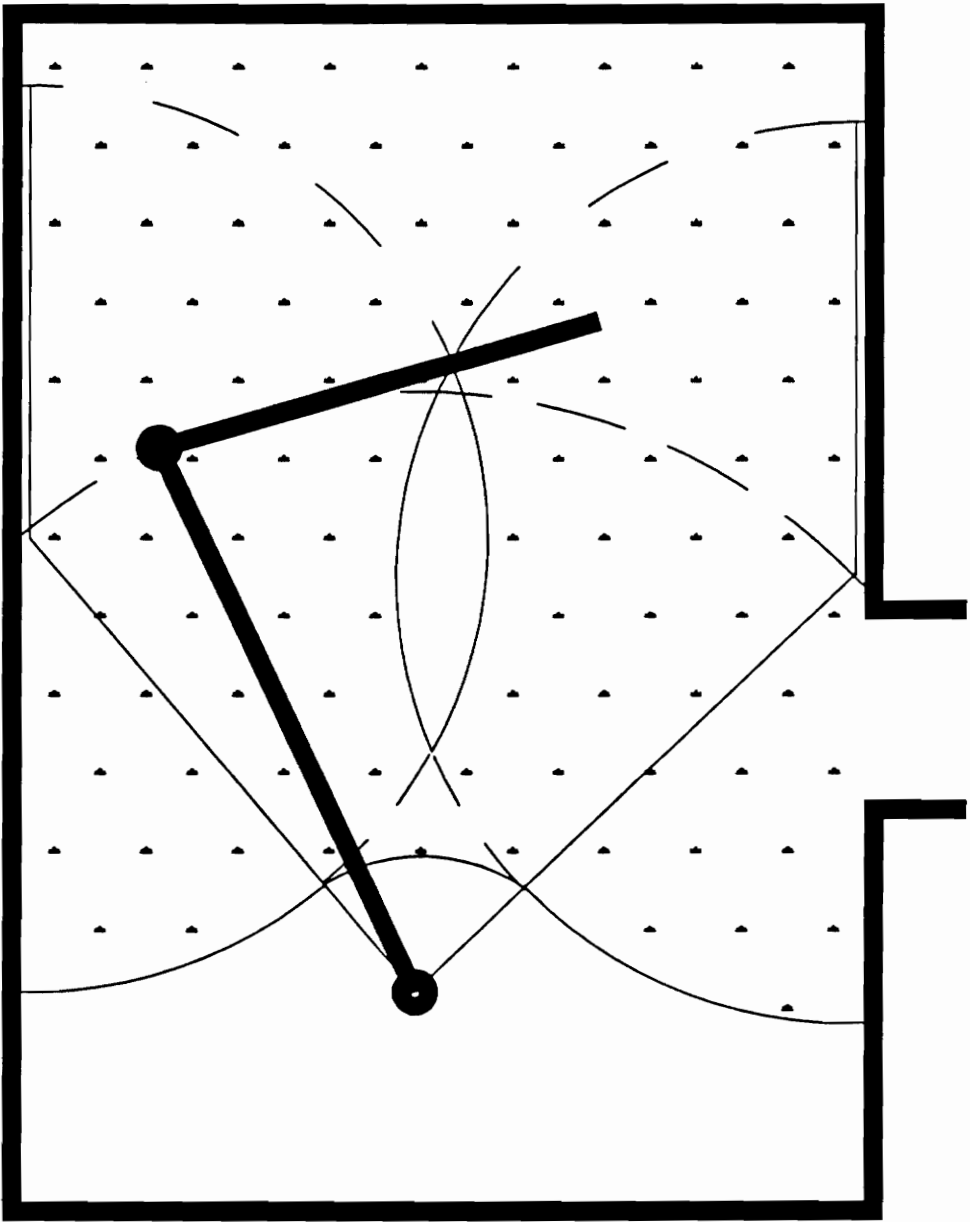

Figure 3.4: Workspace Constrained By Environment

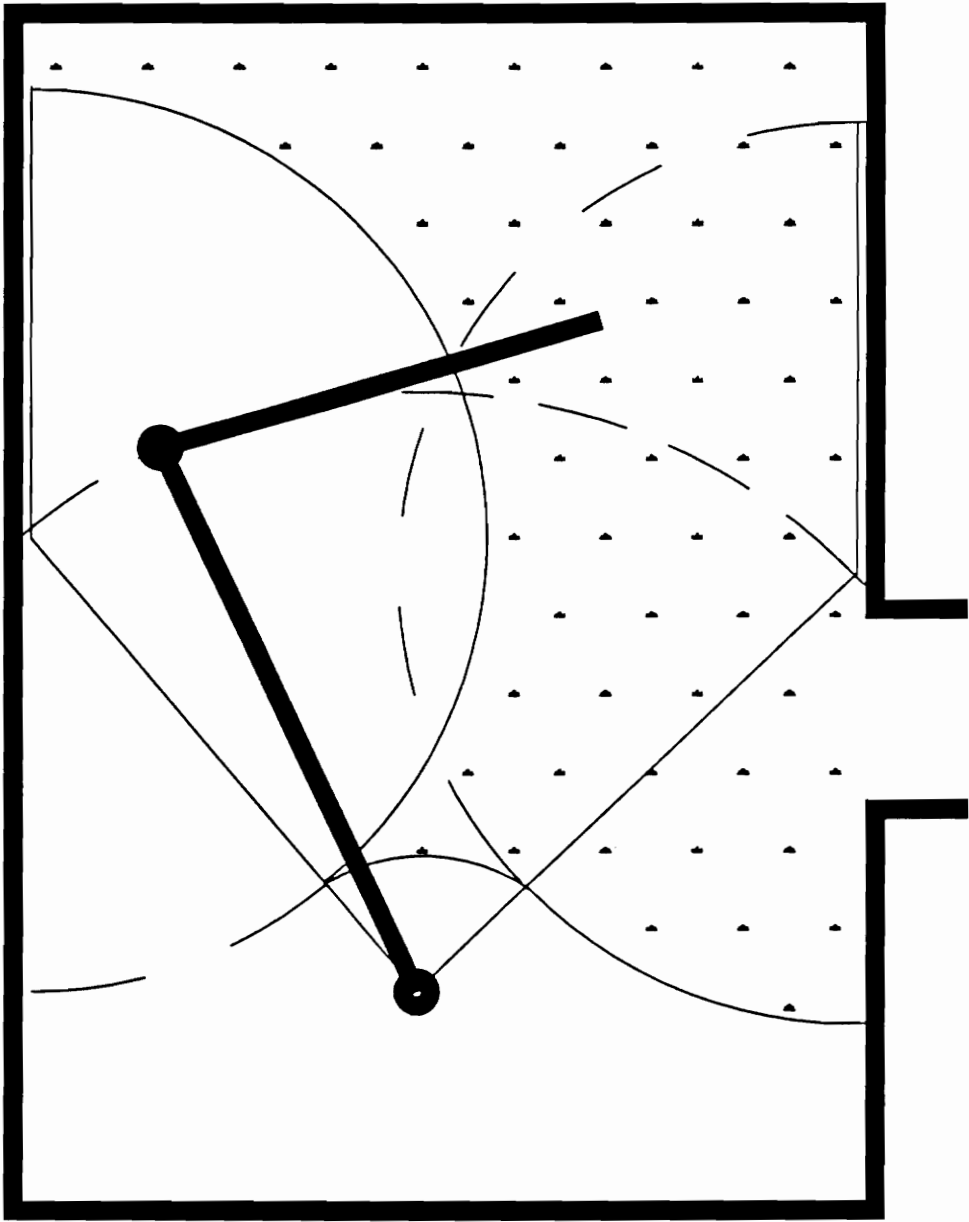

Figure 3.5: Limited Attainable Workspace

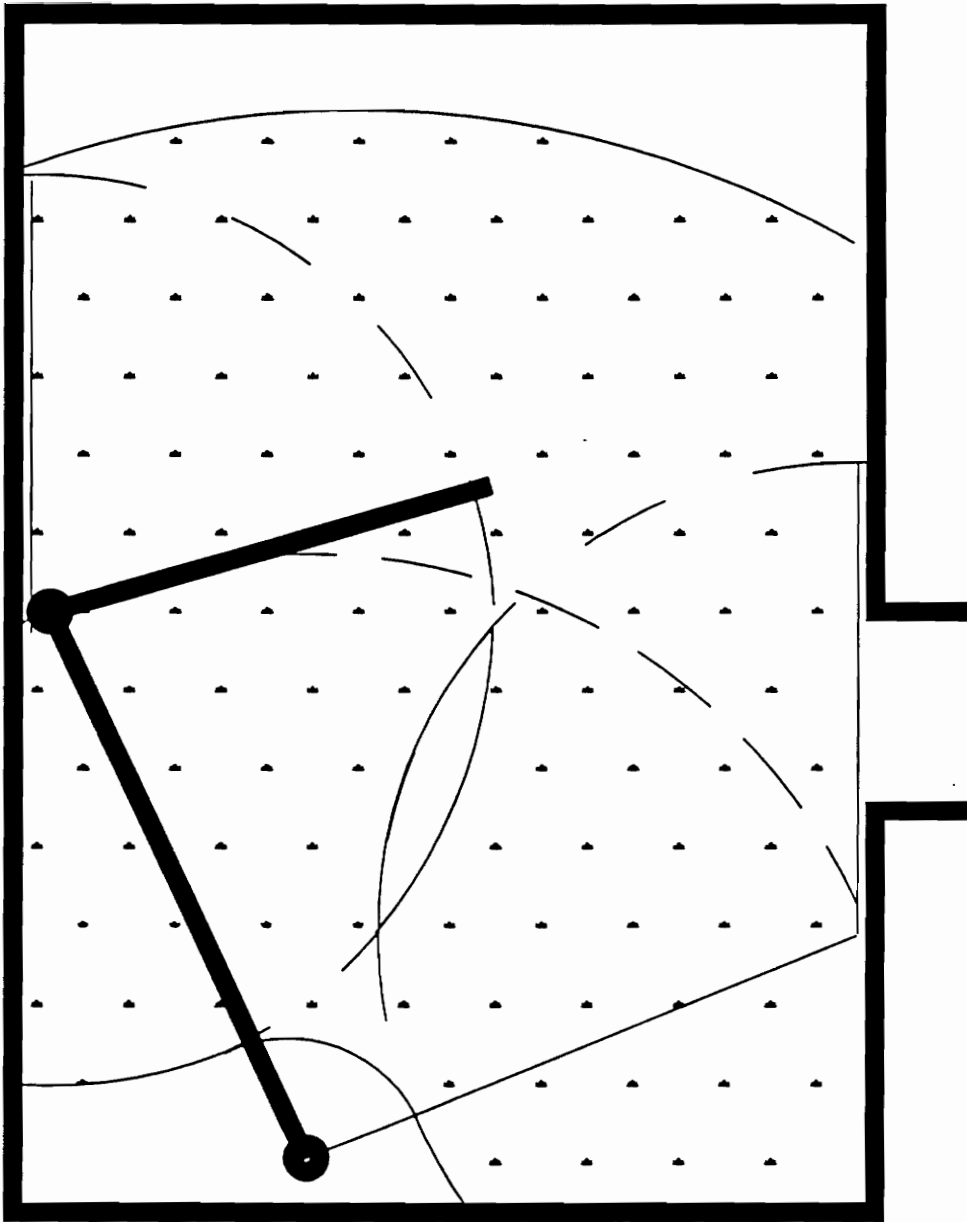

Figure 3.6: Alternative Base Location

and joint size.

The complexity of the analysis increases greatly when three-dimensional space and additional degrees of freedom are considered. A well-formulated kinematic model must be developed. The model must include the manipulator and the work environment. With such a model, the target workspace can be searched for attainability by the manipulator.

Upon review of these design considerations, it is clear that it is necessary to optimize the base, or mezzanine, position in tandem with the link dimensions, joint types, offsets and degrees-of-freedom. In some applications it may become apparent that multiple mezzanine positions will be necessary, thus requiring mobility of the mezzanine.

3.5 Mezzanine Base Design

Another criterion of great importance in the design of LAWS manipulators is the ability of the assembly to enter the environment workspace. The question arises: Is it possible to fit the assembly through the portal? This factor could severely limit the design choices. After it is assured that the manipulator will satisfy the workspace requirements, considerable thought should be given to the means of installation and base placement. An option the designer may wish to consider is passing the assembly through the portal in parts. This option may or may not be possible for a given application. It is certain that the mezzanine base design is not a trivial task.

Because of the confined nature of the environment, implementation factors must also be strongly considered. Assembly, installation, calibration, path planning and control strategy must be considered before a design can be accepted.

Chapter 4

Design of a LAWS Robot

The design and analysis of LAWS robots requires consideration of several attributes. Now that these attributes have been presented, it is best to demonstrate the design considerations with a specific example. The design is presented following the system illustrated by Sandor's "Seven Stages of Engineering Design". It is important to recognize that the actual design did not flow in a linear fashion. For instance the Synthesis, Analyzable Model, and Experiment, Analysis, and Optimization stages occurred concurrently and iteratively. However, for organization and clarity, the design will be presented in Sandor's format.

4.1 Confrontation

The confrontation resulted from a request from the project sponsor to develop and refine advanced concepts for robotic manipulators to be used in the inspection and maintenance of nuclear steam generators. While a manipulator was already in use for this task, the manipulator was found to be heavy and awkward to install. The objective was then to maintain and improve upon the functional capabilities inherent in the present manipulator and improve the portability and installation of the manipulator. Because of the high radioactivity in the steam generator, a primary

concern was the reduction of radiation exposure to personnel during operations.

4.2 Formulation of the Problem

Because the confrontation was indefinite, it was necessary to clarify the problem by ascertaining the “real need” and defining the problem in concrete terms. This required an understanding of the environment in which the manipulator would operate as well as the necessary manipulator characteristics needed to perform the operations.

The manipulator must perform inspection and maintenance of steam generators in nuclear power plants. Steam generators are large heat exchangers where the radioactive steam from the reactor transfers heat to the “clean” steam which runs the turbines. The steam generator consists of up to 15,000 tubes through which the steam passes. Although there are several designs for the arrangement of the tubes, the generators share a common characteristic of a hemispherical head at the end of the tubes which is often referred to as the “bowl”. The planar surface at the top of the hemisphere is called the “tubesheet” because this area contains the ends of the tubes. The head, or bowl, which is most often encountered is separated into two quarterspheres by a “divider plate”. Each of the quarterspheres of the bowl are accessible through a manway, a hole in the 254 mm thick steel casing.

The exact dimensions of the bowl and the position of the manway may vary for various steam generator designs. The case used in this thesis for conceptual design exploration consisted of a bowl with an interior radius of approximately 1525 mm and the center of the 406 mm diameter manway located at an angle of 22 degrees from the divider plate and 45 degrees from the tubesheet. The quartersphere environment, or bowl, is shown in Figure 4.1.

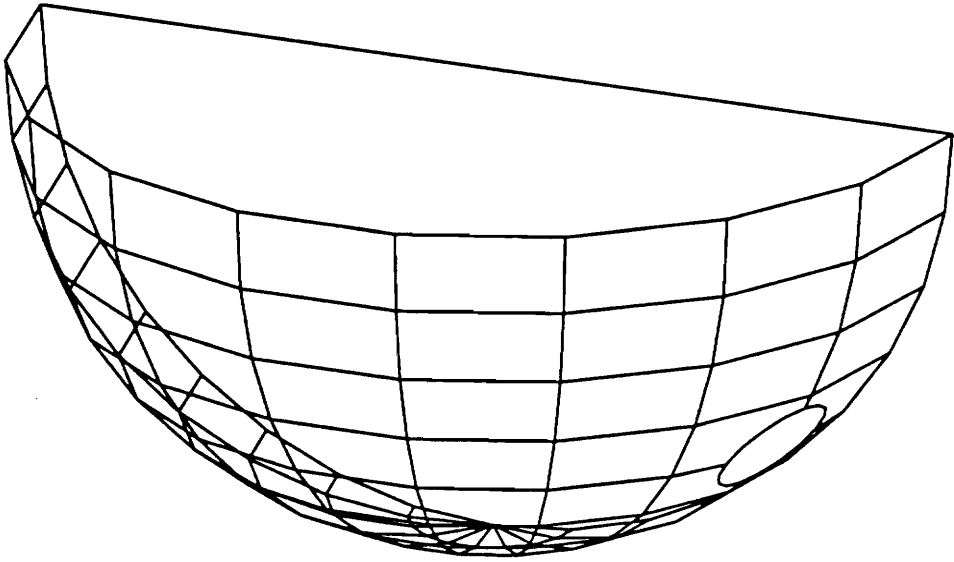

Figure 4.1: Quartersphere Environment or "Bowl"

The manipulator must enter the bowl through the manway and operate within the quarterspherical environment with the capability of accessing any of up to 15,000 tube locations on the tube sheet. The manipulator must also be able to provide 254 mm of vertical travel below any of the tubes. The manipulator must be able to fit through the 406 mm diameter manway and be installed without any part of the operator entering the environment (called a “jump”). With all of this in mind, the **environment workspace** is then defined as being bound by the walls of the quartersphere. The **target workspace** extends from the tubesheet to a plane 254 mm below. It is also necessary for the manipulator to reach back out the manway for tool changes.

The existence of a manipulator already in use provided for exact specifications for the new manipulator to match and surpass. However, the long list of specifications had to be reduced to a manageable number of well-defined target objectives for the new manipulator. While it was recognized that the manipulator must meet the specifications described by the sponsor, the objectives could be described by the following points.

1. The manipulator is intended for inspection of steam generator tubes, plugging and sleeving. These operations should be accomplished with minimal reliance on operator skill.
2. The manipulator must be installed for operation and removed upon completion of its tasks. The manipulator assembly must fit through the 406 mm diameter manway to enter the bowl.
3. The manipulator should be able to reach ALL tubes. It is desirable that the manipulator be capable of approaching any tube from various angles to provide

the best possible approach for a tool head. Sleeving requires that at least 254 mm of vertical travel be provided at each tube location.

4. Personnel exposure to radiation should be minimized for installation, tool changes and removal.
5. The manipulator should be reliable in service and should be retractable from the steam generator in all possible modes of failure.
6. The manipulator assembly must be portable for transportation to the site of the steam generator. The manipulator should be separable into components of no more than 22.7 kg each, and have a total mass of no more than 45.4 kg.
7. While the manipulator must be as light as possible, it must maintain adequate stiffness in operation. The minimal acceptable stiffness at any tube location is 21.9 N/mm.
8. Speed of movement from one tube to another should be maximized.
9. The manipulator must be capable of operating with other support equipment in the bowl.
10. No alterations can be made to the steam generator.

The specifications for the manipulator provided by the sponsor contain greater detail of the required operations of the manipulator. However, it was felt that consideration of more details would hinder the generation of concepts. The above description was considered adequate to begin the process of creatively generating design concepts.

4.3 Development of Concepts and Selection

With the problem well formulated, design concepts were developed utilizing the creative techniques described in Chapter 2. Several brainstorming sessions were held, and a number of concepts were generated. Similarities of the characteristics of the concepts prompted grouping them in the five classifications as described in Chapter 3. Two concepts were classified under Class I: Pillar or Mast Based Manipulators as shown in Figure 4.2. Four concepts appear in Figure 4.3 under Class II: Interior Supported, Mezzanine-Based Manipulators. Four concepts were placed in Class III: Portal or Exterior Mounted Mezzanine-Based Manipulators as shown in Figure 4.4, and two concepts were classified as Class IV: Long Chain, Exterior Mounted Manipulators illustrated in Figure 4.5. Finally, four concepts were found to fit Class V: Field-Robot Type Manipulators where the mobility was provided by “fingers” which locked into the tubesheet as shown in Figure 4.6. The concepts are illustrated as viewed from the front of the bowl.

4.3.1 Concept Evaluation

After the concepts were generated and classified, it was necessary to select the best concept for further development and analysis. Evaluation of the concepts can be divided into two types of criteria: screening and evaluative. The screening criteria are a list of requirements that the design must meet to be suitable. The evaluative criteria are a list of attributes which would prove beneficial to the design and can be weighted against other concepts.

For the first down-selection of the concepts, it was necessary to only consider the screening criteria because these proved sufficient to reduce the number of concepts. However, it was difficult without detailed analysis to determine the ability of the

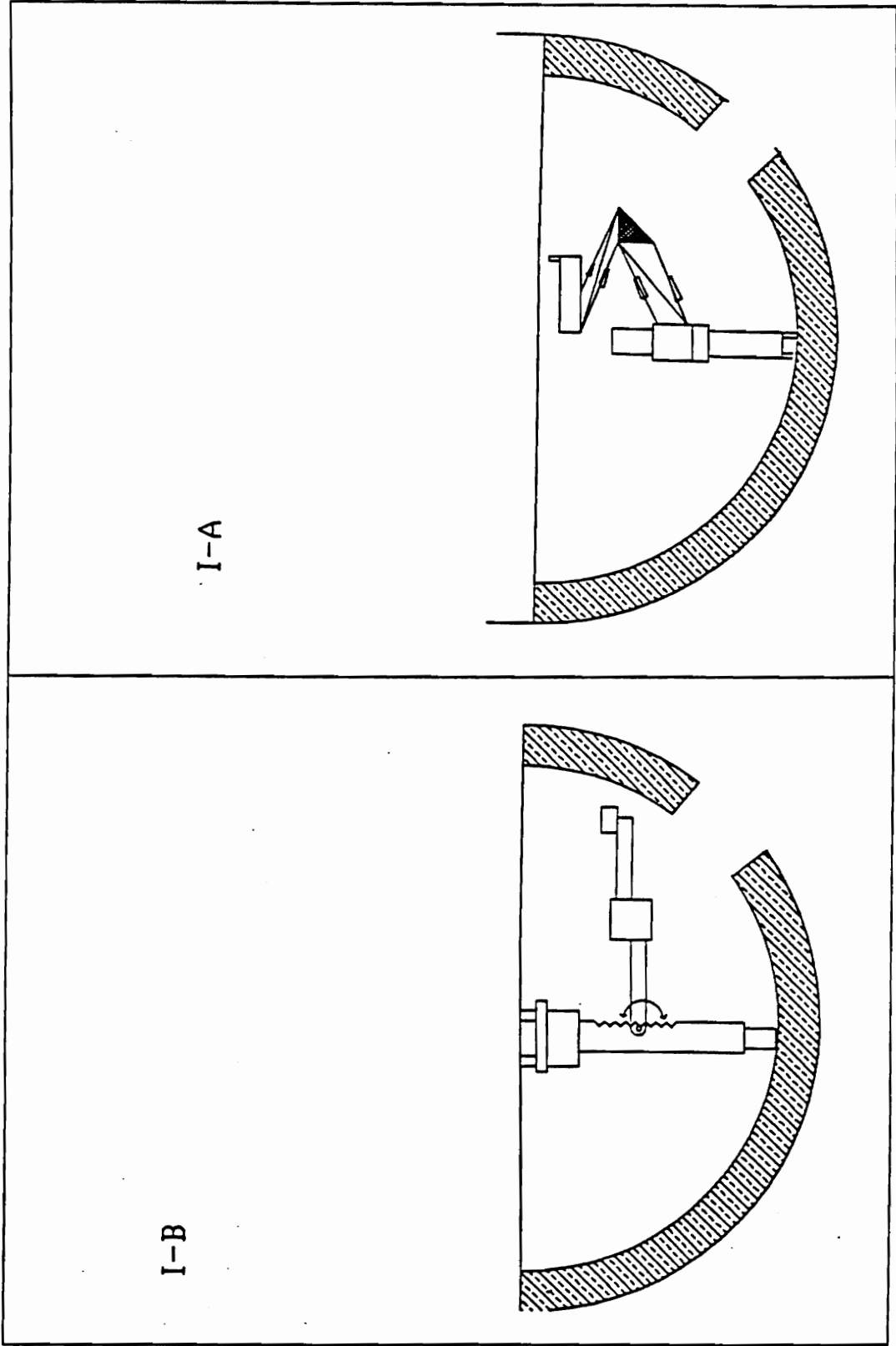

Figure 4.2: Class I: Pillar or Mast-Based Manipulators

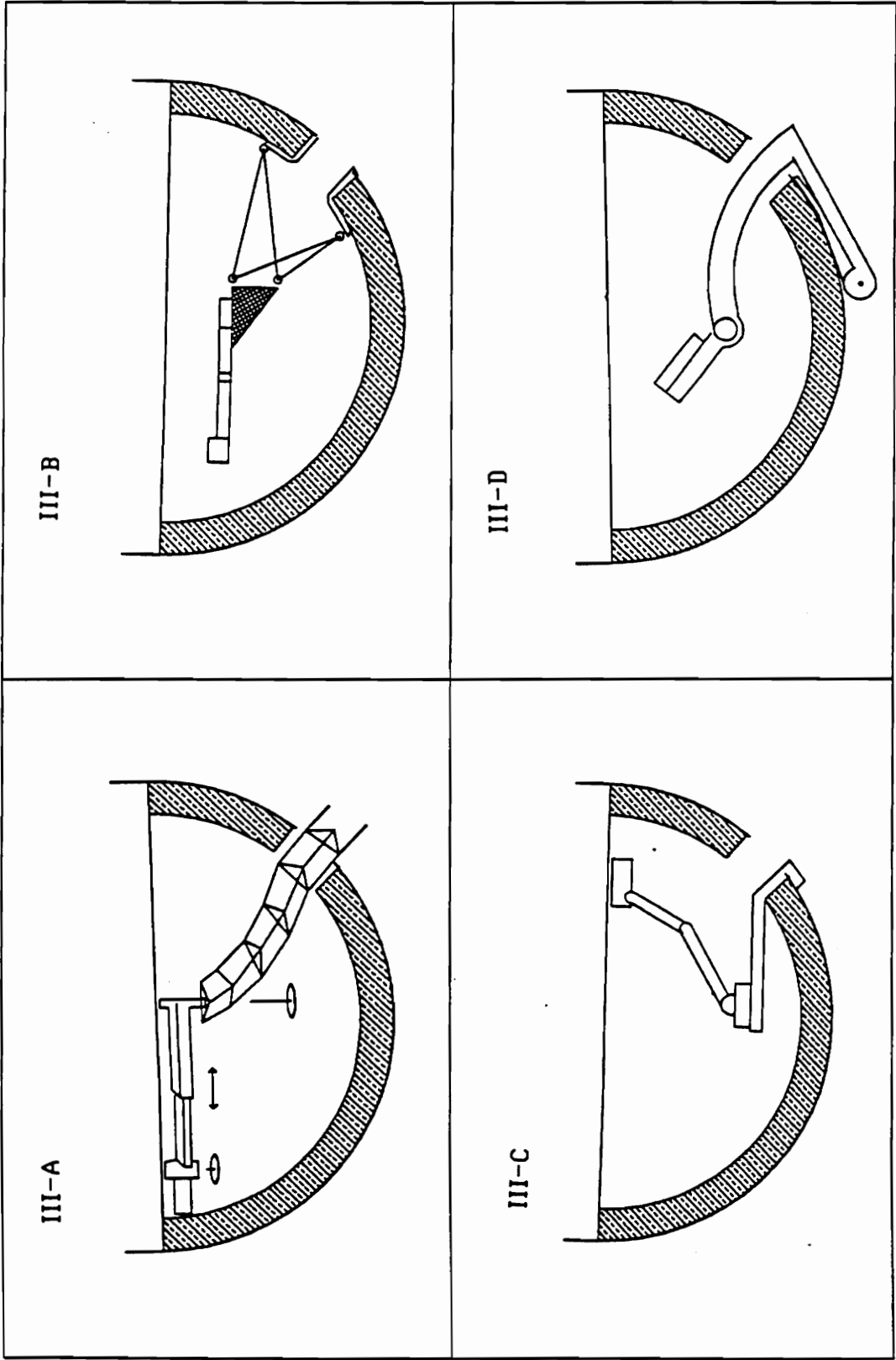

Figure 4.4: Class III: Portal or Exterior Mounted Mezzanine-Based Manipulators

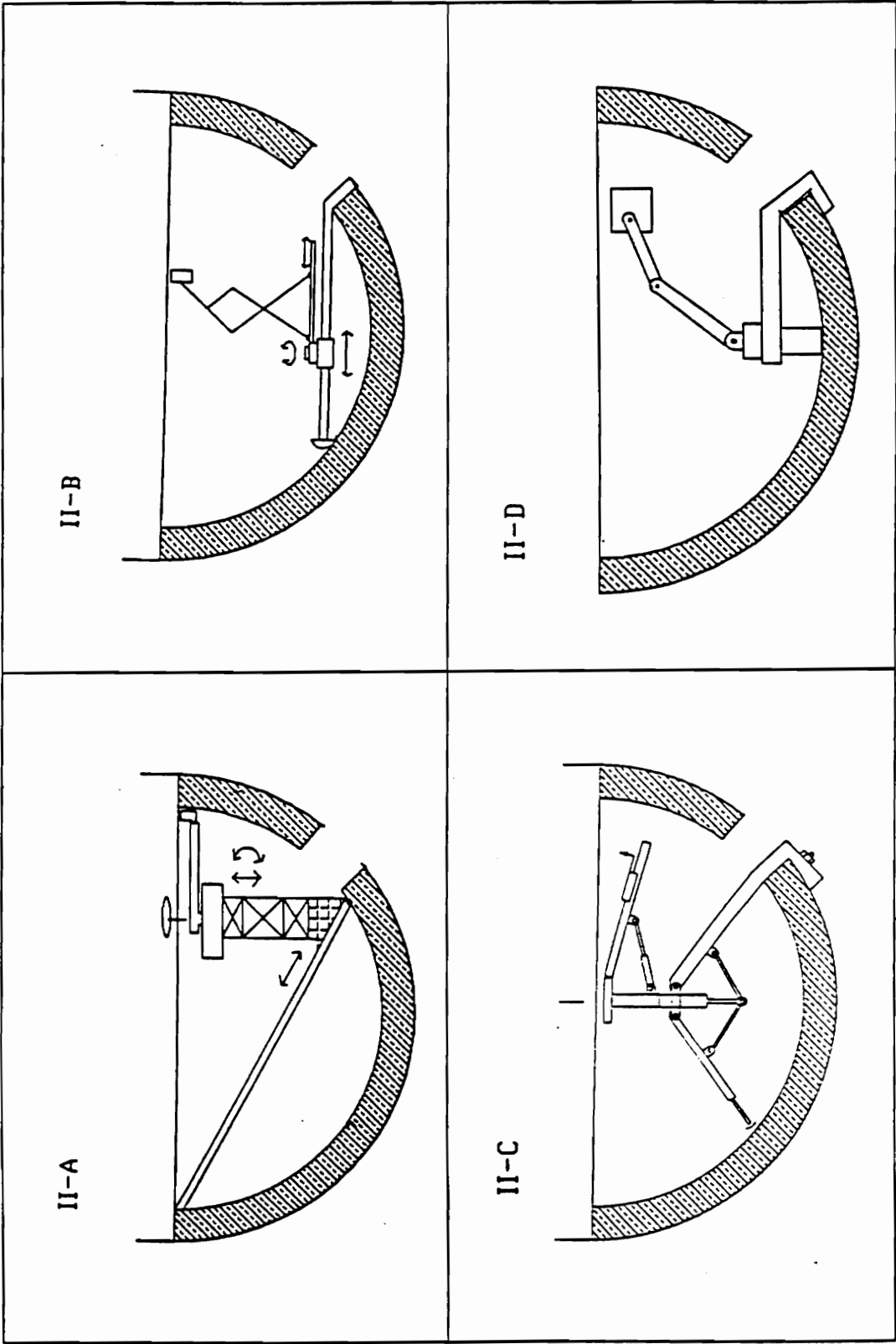

Figure 4.3: Class II: Interior Supported Mezzanine-Based Manipulators

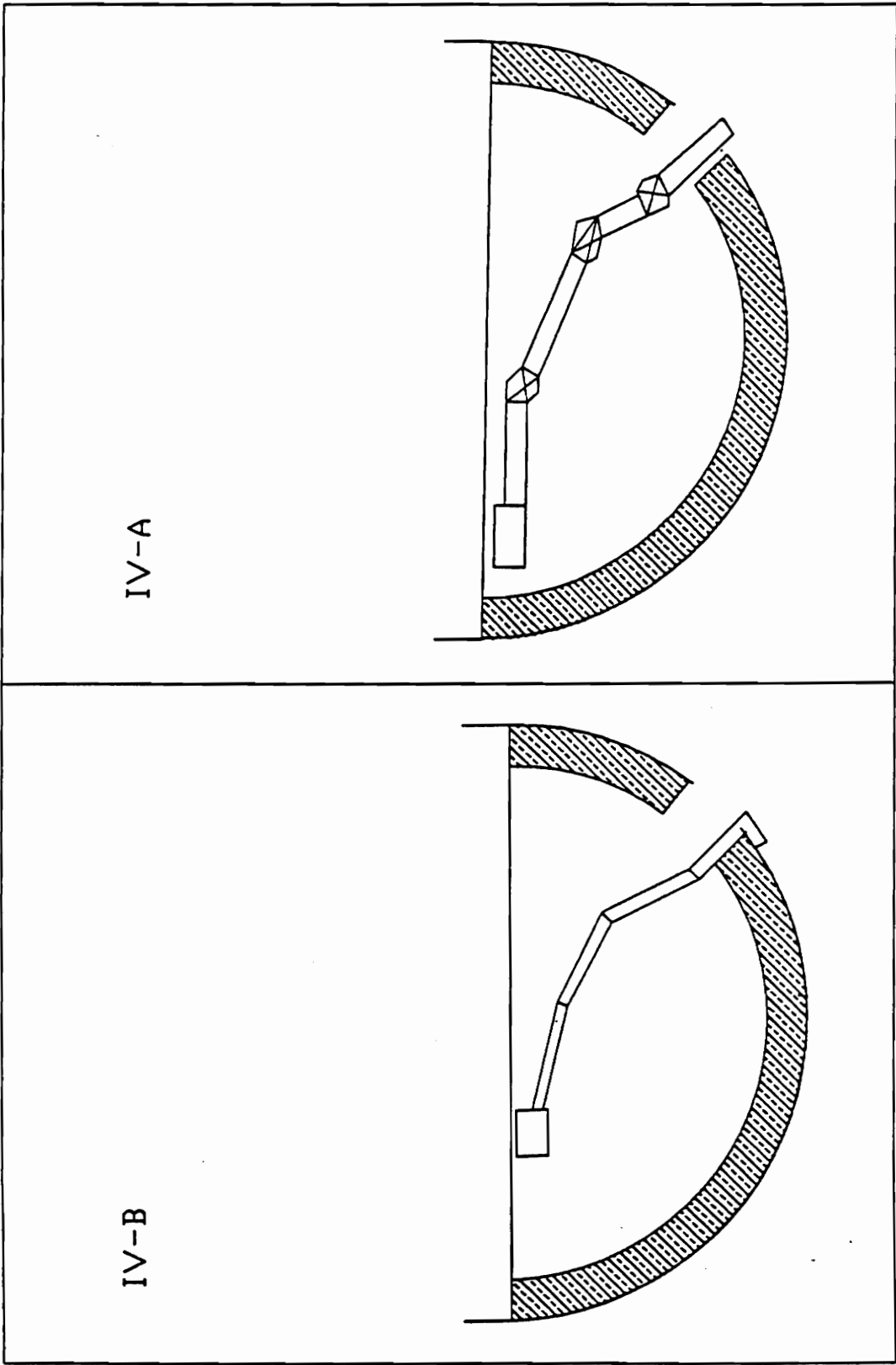

Figure 4.5: Class IV: Long Chain, Exterior Mounted Manipulators

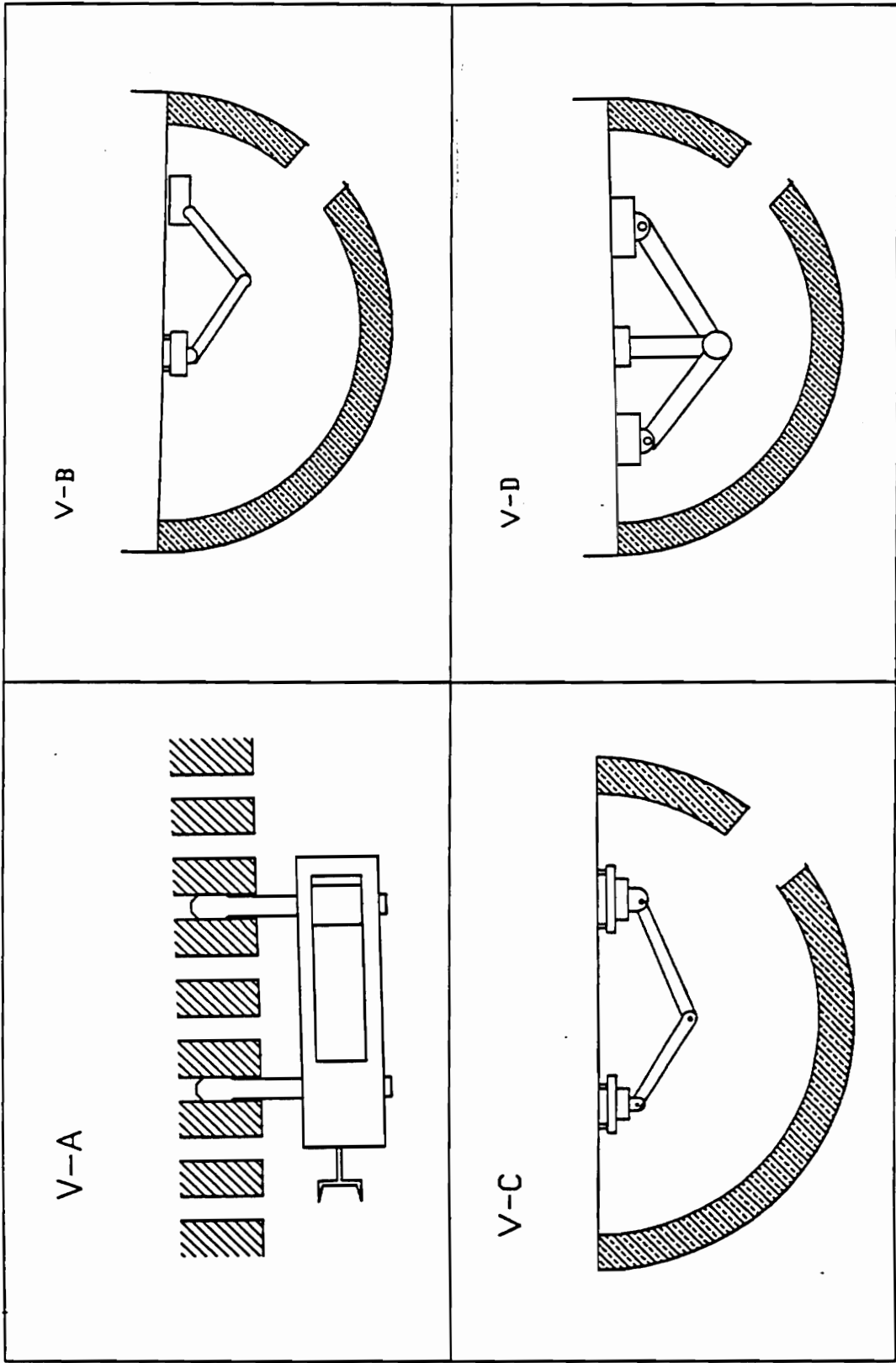

Figure 4.6: Class V: Field-Robot Type Manipulators

designs to meet the screening criteria. For this reason, the designs were not evaluated for a pass/fail ability to meet the criteria. Instead, four categories were used: certain failure to meet the requirement, possible failure to meet the requirement, concern/modification needed to meet the requirement, and requirement met. The results of this screening appear in Table 4.1.

The first screening criteria questioned the ability of the manipulator to fit through the manway. Concept III-A appears to have a problem fitting through the manway. The extended variable geometry truss (VGT) would be larger when collapsed, and the standard manipulator attached to the end would be awkward for insertion. The difficulty with this design is contrasted by concept III-B where the variable geometry truss is a single bay and can be collapsed like a tripod. Concept II-A clearly has a problem fitting through the manway by the nature of its elevator platform. II-B and II-C appear to be close to not meeting the requirement; however, modifications and careful design could allow them to pass through the manway.

All of the concepts passed the requirement of no alterations to the steam generator.

Both of the mast-based designs prompted concern over their ability to reach the work volume. These manipulators would require moving the mast to reach the tubes above the mast position. II-A would have trouble reaching the tubesheet in the far corner where the plank would have to be supported. II-C would have difficulty reaching directly overhead and would require moving the manipulator or modifying the design. The fingerwalker concept V-A would have trouble navigating around plugged tubes.

All of the concepts appeared to meet the requirement of transportability to the steam generator. If the manipulator could not be transported in one piece, it could

Table 4.1: Screening Criteria

Screening Criteria	I		II				III				IV		V				
	A	B	A	B	C	D	A	B	C	D	A	B	A	B	C	D	
Must fit through 406 mm manway.			P	C	C	C	P										C
No alterations to the steam generator.																	
Must reach work volume.	C	C	C	C									F				
Must be easily transported to generator																	
Retractable from the generator in the event of component failure			C	C					C				C	C	C	C	C
Stable platform capable of taking all required loads							P		C	C	C	C					
Installable with maximum rigid length of 1370 mm.			P	C	C	C	C	P	C								
No jumps permitted for setup, removal, or tool loading	P	P					C	C									P
Integrity of the design.																	C
																	C
																	C
																	C

LEGEND

- Blank - requirement met
- C - Concern/modification required to meet requirement
- P - Probable Failure to meet requirement
- F - Failure to meet requirement

be carried in separate components.

Each manipulator would have to be retractable from the generator in the event of component failure. Concept III-D was a concern because the mezzanine would fill most of the manway hindering the ability to get into the generator for disassembly. Concepts II-A and II-B caused concern because of their expanded size in the generator; however, they could be designed with latches for easy disassembly. The field-robot concepts of Class V were all of concern because of the possibility of the fingers becoming locked in the tubesheet. Again, novel design could compensate for this problem.

The manipulator would be required to be stable enough to take all of the required work loads. Because they are cantilevered at the manway or the bowl exterior, the concepts in Class III and Class IV may have a problem with deflection. Concept III-B would be rigid, however, because of its single bay truss design.

Several of the mezzanine-based manipulators prompted concern about meeting size requirements because of the length of the mezzanine base. Concepts II-D and III-C appear to avoid this problem.

A final criteria involved the overall integrity of the design. This criteria was developed to include the concern over the possibility of the field-robot manipulators breaking free of the tubesheet and falling.

4.3.2 Selection

Sixteen conceptual designs were presented and evaluated. It was then necessary to down-select to a manageable number of concepts for further evaluation. The Class I designs were eliminated because they appeared to make only a marginal improvement over the present manipulator in radiation dose, ease of installation,

and the operational characteristics.

The Class III concepts were found to be very appealing because of the mezzanine structure and the mounting at the manway. However, they did prompt concern over stability and deflection. Concept II-D was similar to III-C with the addition of a support base within the bowl. Also note that concept II-D was the only concept found to pass all of the screening criteria. Concept III-C passed all of the criteria except for the concern over stability.

The conceptual design selected for further evaluation was a mezzanine based manipulator similar to concepts II-D and III-C. The detailed design would then develop in two stages consisting of manipulator design and mezzanine base design. The manipulator shown in concepts II-D and III-C was selected for further evaluation. It was yet unclear as to the best mezzanine design. The mezzanine concepts from II-D, III-B, and III-C were accepted as possible concepts for the mezzanine.

4.4 Synthesis

The following three stages occurred iteratively in some instances and concurrently in others. It was determined that while the mezzanine design was by no means trivial, the primary concern was the ability of the chosen manipulator to function and to meet the workspace requirements. The manipulator design was the first area of focus and the mezzanine was represented as a beam which would provide the manipulator's base point. The primary concern here was the development of the kinematic structure of the manipulator to meet the workspace requirements.

The original manipulator concept selected had three links and four degrees-of-freedom provided by the four revolute joints as shown in the concept drawing in Figure 4.7. A kinematic model was generated, and analysis to determine the best

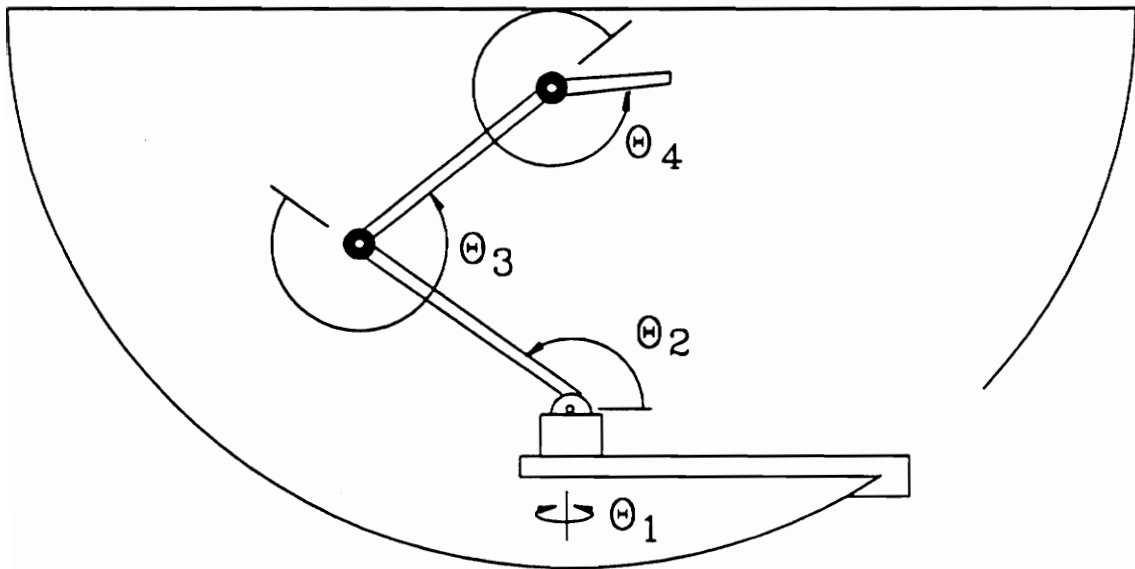

Figure 4.7: Original Manipulator Concept

link lengths and mezzanine position was performed. However, this analysis and the mechanical design considerations indicated the need for the addition of an offset link extending from the mezzanine joint axis to the second joint axis, as shown in Figure 4.8. While the manipulator functions as a planar device, the actual link design shown Figure 4.9 provides for compactness by allowing the links to fold nearly flat without interference.

4.5 Analyzable Model

It was necessary to determine if this concept could meet the design requirements, most importantly, the workspace requirements. To do this, it was necessary to examine various combinations of link dimensions and mezzanine positions, as well as the angles of travel of the joints. This required the development of an accurate mathematical model of both the manipulator and the environment.

4.5.1 Coordinate Frames

To develop the model, it was first necessary to establish the coordinate frames of both the quartersphere environment and the manipulator. The environment, or bowl, coordinate system is defined as $X_B Y_B Z_B$ in Figure 4.10. The manipulator coordinate system is defined at the position of the mezzanine base, point M, as $X_O Y_O Z_O$. The manipulator coordinate frame relates to the environment coordinate frame through the transformation matrix:

$${}^B_O T = \begin{bmatrix} c\alpha c\beta & c\alpha s\beta s\gamma - s\alpha c\gamma & c\alpha s\beta c\gamma + s\alpha s\gamma & {}^B M_x \\ s\alpha c\beta & s\alpha s\beta s\gamma + c\alpha c\gamma & s\alpha s\beta c\gamma - c\alpha s\gamma & {}^B M_y \\ -s\beta & c\beta s\gamma & c\beta c\gamma & {}^B M_z \\ 0 & 0 & 0 & 1 \end{bmatrix} \quad (4.1)$$

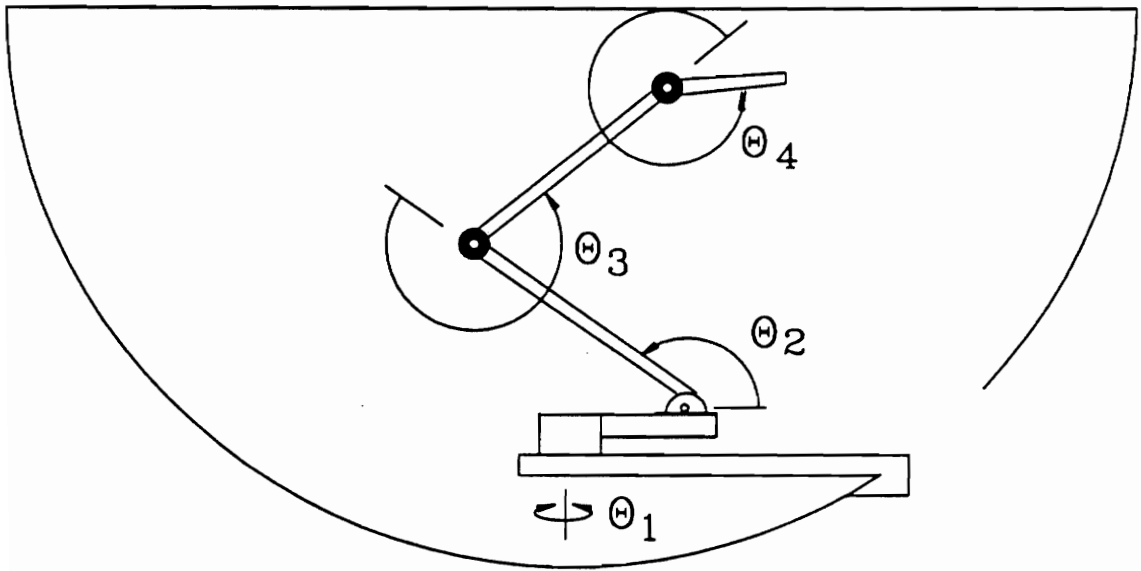

Figure 4.8: Modified Manipulator Concept With Offset Link

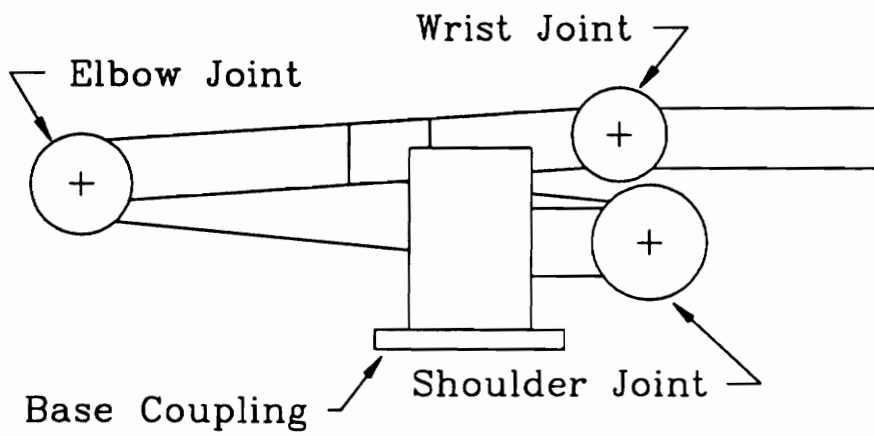
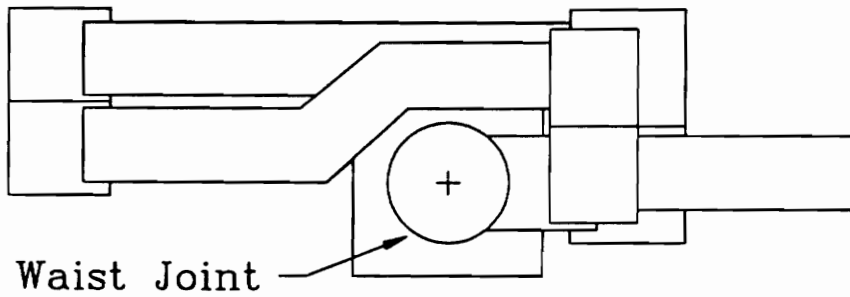

Figure 4.9: Manipulator Design Shown in Collapsed Position

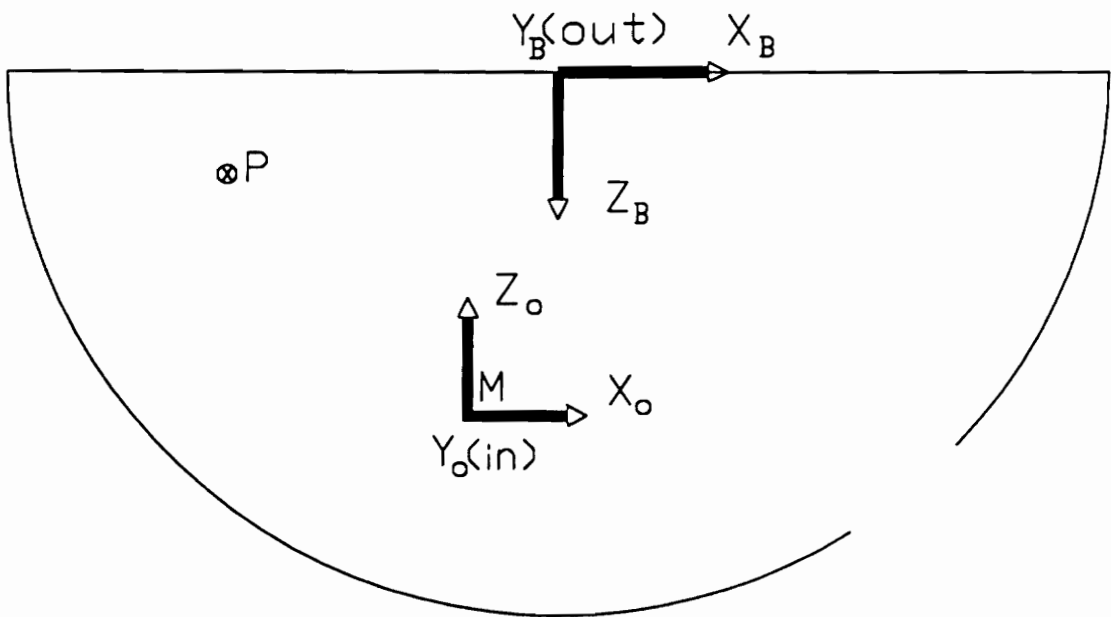

Figure 4.10: Environment and Manipulator Coordinate Systems

where γ - rotation about X_B
 β - rotation about Y_B
 α - rotation about Z_B

It is considered desirable for the orientation of the manipulator's first joint axis to be perpendicular to the tubesheet so that the mezzanine base is level with the tubesheet. In such a case, the transformation matrix can be simplified with $\gamma = 180$, $\beta = 0$, $\alpha = 0$ to:

$${}^B_0T = \begin{bmatrix} 1 & 0 & 0 & {}^B M_x \\ 0 & -1 & 0 & {}^B M_y \\ 0 & 0 & -1 & {}^B M_z \\ 0 & 0 & 0 & 1 \end{bmatrix} \quad (4.2)$$

Methods for accomplishing this levelling will be described later in the thesis.

4.5.2 Workspace Model

With the coordinate systems established, the workspace must be modeled. The environment boundary can be defined by the $X_B Y_B$ plane, the $X_B Z_B$ plane, and the sphere. The environment workspace (i.e. the bowl) is then bounded by the following equations.

$$r = \sqrt{x^2 + y^2 + z^2} < 1525 \quad (4.3)$$

$$y > 0$$

$$z > 0$$

where x , y and z are referenced coordinates in frame B.

The target workspace is then defined by the following equations:

$$r = \sqrt{x^2 + y^2 + z^2} < 1525 \quad (4.4)$$

$$y > 0$$

$$0 < z < 254$$

The manway was modeled as a circle positioned on the surface of the quarter-sphere and oriented toward the origin of the bowl coordinate system. The center of the manway circle is positioned at 22 degrees from the divider plate and 45 degrees from the tubesheet. It was determined that it was not necessary to model other obstacles within the bowl for this analysis.

4.5.3 Manipulator Model

Once the environment was modeled, it was necessary to model the manipulator. The development of the manipulator model required background information on the kinematic arrangement of the manipulator and its operations.

Background

Before the manipulator model can be developed, terminology and conventions must be clarified. Figure 4.11 illustrates the manipulator reaching a desired tool tip location labeled P. The joints of the manipulator can be defined analogous to joints of the human body for easy reference. The first rotational joint is termed the waist and is labeled M. The shoulder, elbow and wrist joints are labeled S, E, and W consecutively. These points can be referenced as vectors in either the bowl

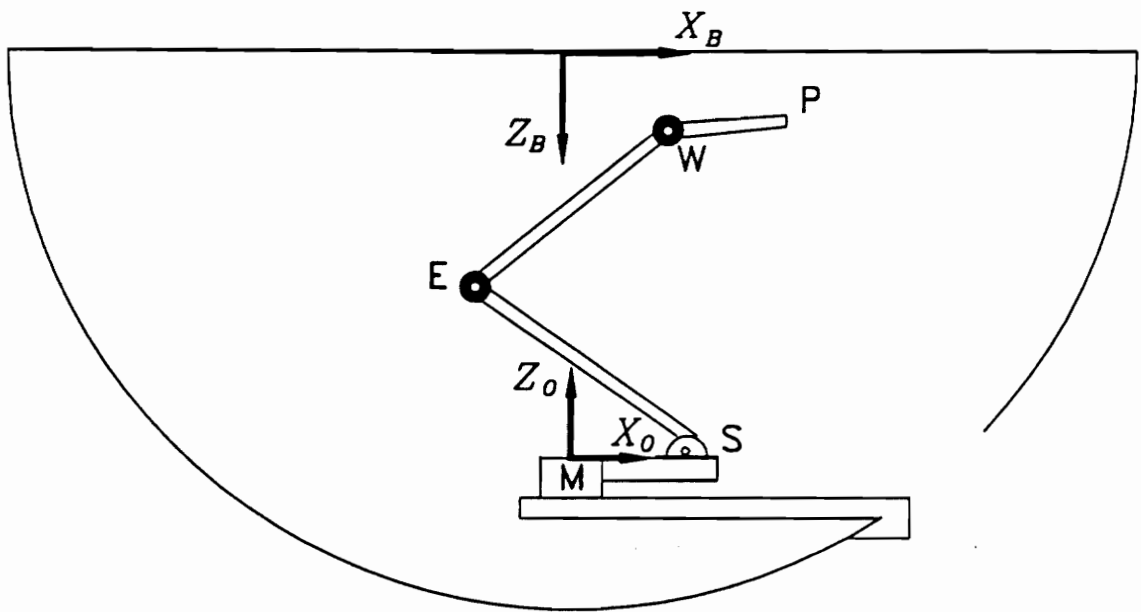

Figure 4.11: Manipulator Illustrating Definitions of Terms

coordinate frame, $X_B Y_B Z_B$, or the manipulator coordinate frame, $X_O Y_O Z_O$. Finally, the analysis procedure requires that the joint angles be referenced with respect to the manipulator coordinate frame. Therefore, the joint angles can be written as follows:

$$\phi_2 = \theta_2 \quad (4.5)$$

$$\phi_3 = \theta_2 + \theta_3 \quad (4.6)$$

$$\phi_4 = \theta_2 + \theta_3 + \theta_4 \quad (4.7)$$

To access a given tube, two distinct values of θ_1 will exist in the most general case. Figure 4.12 shows a top view of the bowl (from above the tubesheet). The two possible θ_1 values have been distinguished as θ_{1OUT} and θ_{1IN} . These are both correct and valid kinematic solutions.

The following convention was adopted:

θ_{1OUT} - the first link points in the direction of the point, P, when viewed in the $X_O Y_O$ plane.

θ_{1IN} - the first link points away from the point, P, when viewed in the $X_O Y_O$ plane.

These are arbitrary, but it is important to keep track of both solutions.

There are eight possible kinematic solutions for the manipulator to reach a given end-effector position as shown in Figure 4.13. However, four of the arrangements result in the tool being inverted. Thus, the kinematic arrangements in I and IV form one possible set, and the kinematic arrangements in II and III form another set. The "elbow out" positions in the figure are most undesirable from an interference viewpoint. It has thus been decided to work only with the closures in I and IV. These can be distinguished by noting that the vector from the waist joint to the

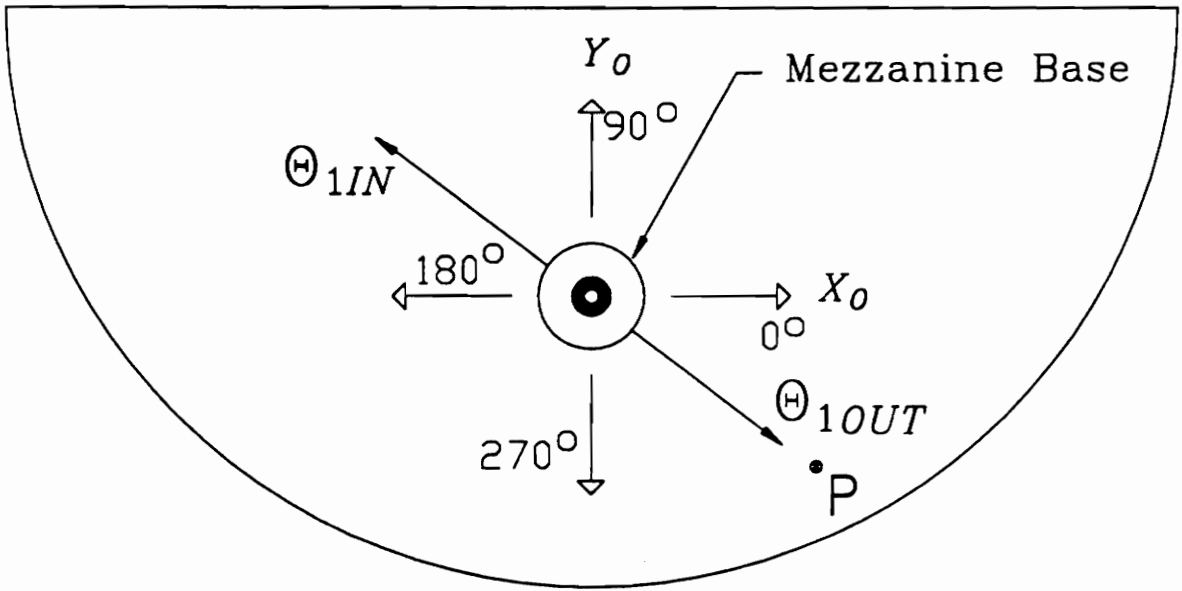

Figure 4.12: Top View of the Bowl Indicating Two Possible θ_1 Values

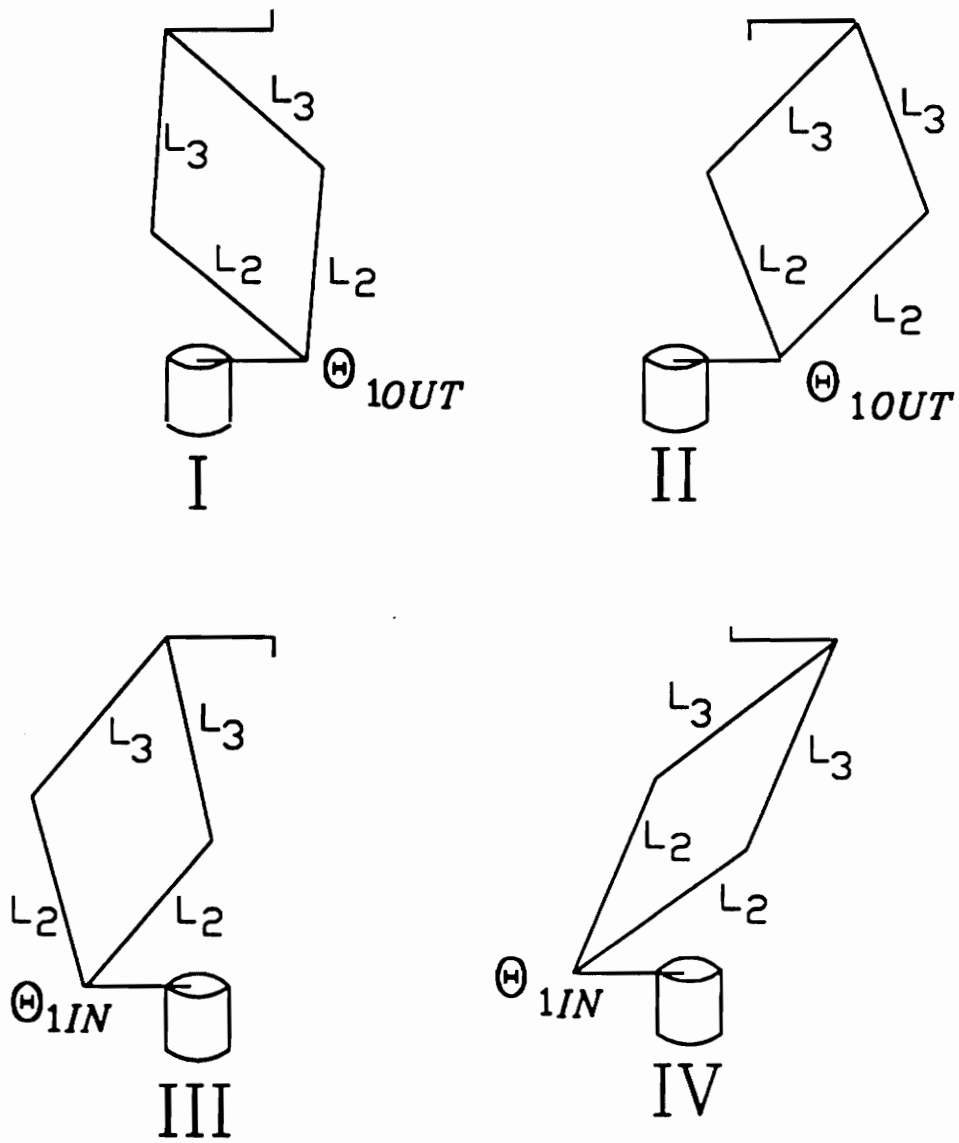

Figure 4.13: Eight Possible Kinematic Solutions

shoulder joint has the same direction and sense as the vector from wrist joint to the end effector. In the undesirable closures these vectors have the opposite sense.

Determination of the Joint Angles Given a Desired Tool Location

Determination of the joint angles requires that the mezzanine location, M , the tool tip location, \mathbf{P} , and that the desired orientation of the tool, ϕ_4 , be known. Assume that the location of the tool tip, \mathbf{P} , is known in the $X_OY_OZ_O$ frame as shown in Figure 4.11. If \mathbf{P} is given in the bowl coordinates as ${}^B P$, then the manipulator base frame coordinates, ${}^O P$, can be obtained knowing the fixed transform ${}^O_B T$ from

$${}^O P = {}^O_B T {}^B P$$

With the tool tip location, \mathbf{P} , obtained, the joint angles θ_1, θ_2 and θ_3 are found with the following procedure.

Determine θ_{1OUT} and θ_{1IN} .

The components of ${}^O P$ are known to be

$${}^O P = \begin{bmatrix} X_P \\ Y_P \\ Z_P \end{bmatrix}$$

One value of θ_1 is calculated as

$$\theta_{1OUT} = ATAN2(Y_P, X_P) \quad (4.8)$$

where ATAN2 indicates that the function for determining the angle in terms of the 4 quadrants of a 360° unit circle is used.

The other value of θ_1 is given by

$$\theta_{1IN} = \theta_{1OUT} + \Pi \quad (4.9)$$

Note that θ_{1OUT} and θ_{1IN} are both valid solutions. The logic for picking one may be based on minimum movement, obstacle avoidance or other considerations.

Determine θ_2 , θ_3 , and θ_4 . Assume that the desired orientation of the tool, ϕ_4 , is given.

With θ_1 known, the planar construction of the manipulator can be used. The plane of operation of the manipulator is determined by θ_1 . Call the plane of operation the X_1Z_1 plane as shown in Figure 4.14. Note the addition of a line, L , from the mezzanine, M , to the tool location, P . And note the angle, ψ , that L makes with the horizontal. These parameters are defined as:

$$\begin{aligned} L &= \sqrt{Z_P^2 + X_P^2 + Y_P^2} \\ \psi_{OUT} &= ATAN2(Z_P, \sqrt{X_P^2 + Y_P^2}) \\ \psi_{IN} &= \Pi - \psi_{OUT} \end{aligned}$$

Note that the two values for ψ relate to the two θ_1 closures, θ_{1OUT} and θ_{1IN} .

Based on this model, a kinematic loop closure equation can be written as follows:

$$L_1 + L_2e^{i\phi_2} + L_3e^{i\phi_3} + L_4e^{i\phi_4} = Le^{i\psi} \quad (4.10)$$

Breaking this into real and imaginary parts gives:

$$\begin{aligned} L_1 + L_2\cos\phi_2 + L_3\cos\phi_3 + L_4\cos\phi_4 &= L\cos\psi \\ L_2\sin\phi_2 + L_3\sin\phi_3 + L_4\sin\phi_4 &= L\sin\psi \end{aligned}$$

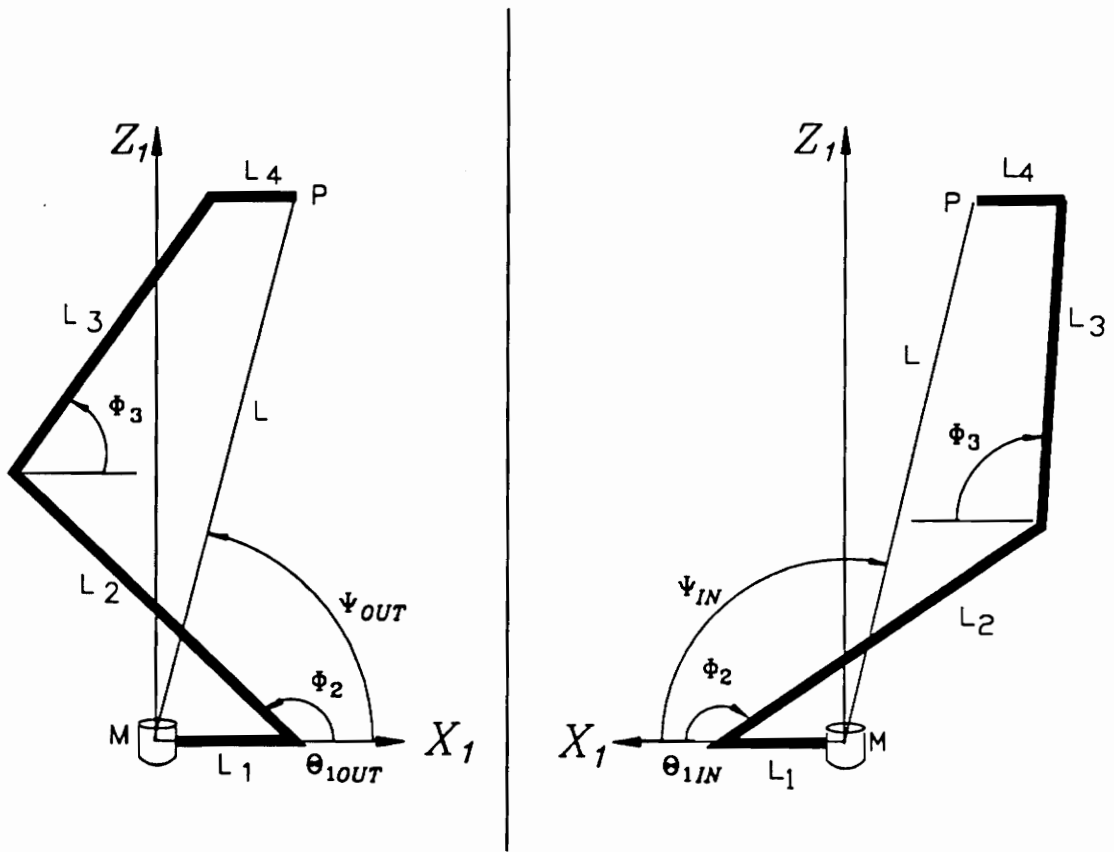

Figure 4.14: Planar View of Manipulator

These two transcendental equations contain only ϕ_2 and ϕ_3 as unknowns. The solution is somewhat complex. Begin by making the following substitutions for known quantities.

$$r_x = L \cos \psi - L_4 \cos \phi_4 - L_1$$

$$r_y = L \sin \psi - L_4 \sin \phi_4$$

Rearrange the equations to a more convenient form.

$$L_3 \cos \phi_3 = r_x - L_2 \cos \phi_2$$

$$L_3 \sin \phi_3 = r_y - L_2 \sin \phi_2$$

Square these and add them to obtain

$$L_3^2(\cos^2 \phi_3 + \sin^2 \phi_3) = r_x^2 + r_y^2 - 2r_x L_2 \cos \phi_2 - 2r_y L_2 \sin \phi_2 + L_2^2(\cos^2 \phi_2 + \sin^2 \phi_2)$$

or

$$L_3^2 = r_x^2 + r_y^2 - 2r_x L_2 \cos \phi_2 - 2r_y L_2 \sin \phi_2 + L_2^2$$

The system has been reduced to one equation in ϕ_2 , but it is still transcendental.

Make the following substitutions

$$\cos \phi_2 = \frac{1 - t^2}{1 + t^2}$$

$$\sin \phi_2 = \frac{2t}{1 + t^2}$$

where

$$t = \tan(\phi_2/2)$$

Substituting these into the previous equations, and moving everything to the

right-hand side gives

$$0 = r_x^2 + r_y^2 - L_3^2 + L_2^2 - 2r_x L_2 \frac{1-t^2}{1+t^2} - 2r_y L_2 \frac{2t}{1+t^2}$$

Multiplying through by $1+t^2$ and grouping terms gives

$$0 = (r_x^2 + r_y^2 - L_3^2 + L_2^2 + 2r_x L_2)t^2 + (-4r_y L_2)t + (r_x^2 + r_y^2 - L_3^2 + L_2^2 - 2r_x L_2)$$

or, in compact form

$$0 = At^2 + Bt + C$$

The two values of t are found from

$$t_p = \frac{-B + \sqrt{B^2 - 4AC}}{2A}$$

$$t_m = \frac{-B - \sqrt{B^2 - 4AC}}{2A}$$

Where the plus (P) and minus (M) roots of the quadratic formula relate directly to the different possible kinematic solutions.

Now, since $t = \tan(\phi_2/2)$, ϕ_2 can be found as

$$\phi_2 = 2\arctan(t) \tag{4.11}$$

The procedure can be repeated to solve for ϕ_3 or the following relationship can be used.

$$\phi_3 = \text{ATAN2}(r_y - L_2 \sin \phi_2, r_x - L_2 \cos \phi_2) \tag{4.12}$$

Here, the ATAN2 function should be utilized to produce a numerical solution in the correct quadrant.

Having solved for all possible sets of ϕ_2 and ϕ_3 , the four acceptable geometries of the manipulator are now known. The values for the joint angles, θ_2 , θ_3 and θ_4 , can be obtained by substituting the values for ϕ_2 , ϕ_3 , and ϕ_4 back into equations 4.5, 4.6, and 4.7.

4.6 Experiment, Analysis, and Optimization

4.6.1 Forward Kinematic Analysis

Once $\theta_1, \theta_2, \theta_3$, and θ_4 have been determined, the forward kinematic solution can be utilized to determine the location of any point on the manipulator. The correlation of the manipulator location with the environment model can be used to determine interference with the environment boundaries. The most logical points on the manipulator to search are the joint locations. The shoulder point, 0S , the elbow point, 0E , and the wrist point, 0W , are found to be:

$${}^0S = \begin{bmatrix} l_1 \cos \theta_1 \\ l_1 \sin \theta_1 \\ 0 \end{bmatrix} \quad (4.13)$$

$${}^0E = \begin{bmatrix} (l_1 + l_2 \cos \theta_2) \cos \theta_1 \\ (l_1 + l_2 \cos \theta_2) \sin \theta_1 \\ l_2 \sin \theta_2 \end{bmatrix} \quad (4.14)$$

$${}^0W = \begin{bmatrix} (l_1 + l_2 \cos \theta_2 + l_3 \cos(\theta_2 + \theta_3)) \cos \theta_1 \\ (l_1 + l_2 \cos \theta_2 + l_3 \cos(\theta_2 + \theta_3)) \sin \theta_1 \\ l_2 \sin \theta_2 + l_3 \sin(\theta_2 + \theta_3) \end{bmatrix} \quad (4.15)$$

The location of these points can then be found in the environment coordinate frame by applying the transformation 0T .

4.6.2 Clearance Determination

For a given tool location, the foregoing analysis could provide up to four unique kinematic solutions. It is then necessary to determine which of these solutions are acceptable for the workspace. This requires the development of a clearance detection scheme. For this manipulator it is important to check the location of each of the joints. Each joint must be checked for its position relative to the bowl boundary. The clearances are shown in Figure 4.15 and relate directly to the three equations defining the workspace as follows:

Clearance 1 - minimum radial distance from the joint to the quarter-sphere wall

$$\begin{aligned}
 \text{Clearance } 1S &= r_{\text{bowl}} - \sqrt{{}^B S_x^2 + {}^B S_y^2 + {}^B S_z^2} & (4.16) \\
 \text{Clearance } 1E &= r_{\text{bowl}} - \sqrt{{}^B E_x^2 + {}^B E_y^2 + {}^B E_z^2} \\
 \text{Clearance } 1W &= r_{\text{bowl}} - \sqrt{{}^B W_x^2 + {}^B W_y^2 + {}^B W_z^2}
 \end{aligned}$$

Clearance 2 - minimum distance from the joint to the $X_B Y_B$ plane ($y = 0$)

$$\begin{aligned}
 \text{Clearance } 2S &= {}^B S_y - 0 = {}^B S_y & (4.17) \\
 \text{Clearance } 2E &= {}^B E_y - 0 = {}^B E_y \\
 \text{Clearance } 2W &= {}^B W_y - 0 = {}^B W_y
 \end{aligned}$$

Clearance 3 - minimum distance from the joint to the $X_B Y_B$ plane ($z = 0$)

$$\begin{aligned}
 \text{Clearance } 3S &= {}^B S_z - 0 = {}^B S_z & (4.18) \\
 \text{Clearance } 3E &= {}^B E_z - 0 = {}^B E_z \\
 \text{Clearance } 3W &= {}^B W_z - 0 = {}^B W_z
 \end{aligned}$$

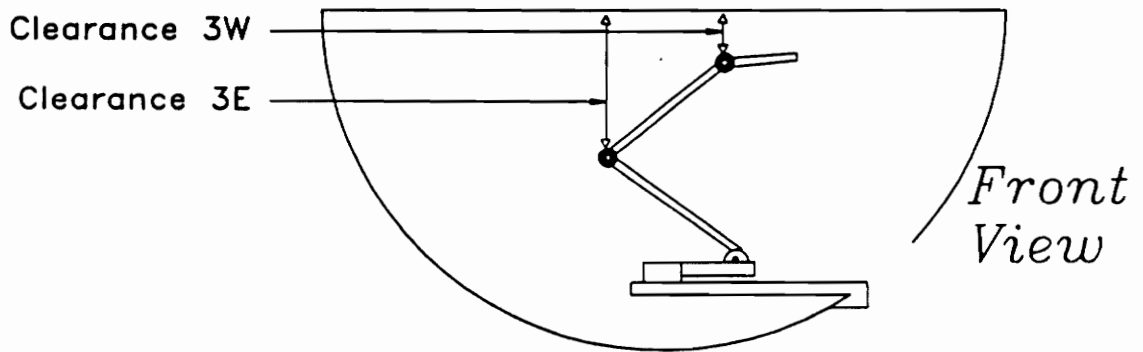
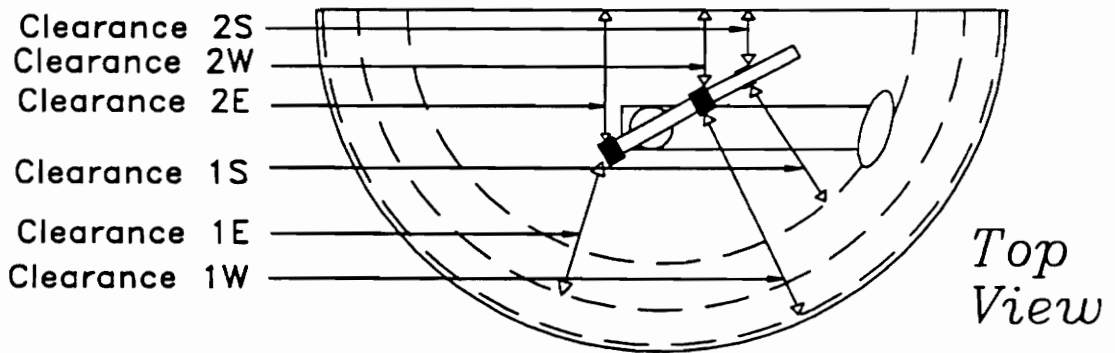

Figure 4.15: Clearances (Note: dashed arcs in figure indicate bowl radius at that height)

For a solution to be acceptable, all of the clearances must be greater than the joint housing radius, assuming a cylindrical joint housing. Those solutions with unacceptable clearances are eliminated.

For a given set of link dimensions, L_1 , L_2 , L_3 , and L_4 , and mezzanine location, M , this analysis must be performed for a sufficient number of tool locations, P , and wrist angles, θ_4 , to cover the target workspace. If the analysis determines that there is not an acceptable solution for any tool location in the target workspace, then the given link dimensions or the mezzanine location must be changed. The iterative process must consider the link dimensions in tandem with the mezzanine location.

4.6.3 LAWS Analysis Program

Because of the iterative nature of the analysis process, a computer program was developed to explore the various link dimensions and mezzanine locations. The program was written in LISP language and utilized the Autocad drawing environment. The program allows for control over the following variables:

1. Bowl radius
2. Position of the manway
3. Manway radius
4. Position of the mezzanine base of the manipulator, point M .
5. Tool length
6. Offset link length, L_1
7. Link length ratio, L_2/L_3

8. Tool orientation angle, ϕ_4

The program will determine the following:

1. The furthest point on the tubesheet from the mezzanine base and use this point as the design point.
2. The link lengths of the manipulator required to reach the design point based on the given ratio L_2/L_3 .
3. All kinematic solutions of the manipulator to reach the point.
4. The position of each of the joints in relation to the bowl coordinate system.
5. Clearances of each of the joints to the bowl boundary, divider plate and tubesheet.
6. Static torques at each of the manipulator joints.

The program allows the user to enter any tool location in the bowl. The program will then calculate the necessary joint angles to reach the point with all possible solutions. In addition, the program draws a stick figure of the manipulator in the bowl in any of the possible configurations. The program is set to view the manipulator and the bowl from the top, bottom, and side views, along with an isometric view. The manipulator can be viewed from any vantage point desired. Any parameter for the design may be viewed. In addition, certain parameters of particular interest are written to a file to permit later creation of plots.

The program was utilized to determine the optimum link lengths and the best mezzanine location for the manipulator to reach the target workspace while operating within the confines of the bowl.

4.7 Presentation

The analysis and optimization procedure produced the parameters for the final manipulator design, including the mezzanine location and the link lengths. Analysis indicated that the final manipulator design met the workspace constraints. The target workspace can be reached while providing sufficient clearance to the environment boundaries. The link shapes were determined to allow for the manipulator to fold compactly for transport to the worksite and for installation. Unfortunately, the actual parameters for the final design are proprietary and can not be presented here. However, it is the design procedure that is of primary interest in this work.

A prototype of the manipulator has been built. A picture of the prototype installed in a mock-up of the bowl appears in Figure 4.16. The figure shows the manipulator accessing the tubesheet.

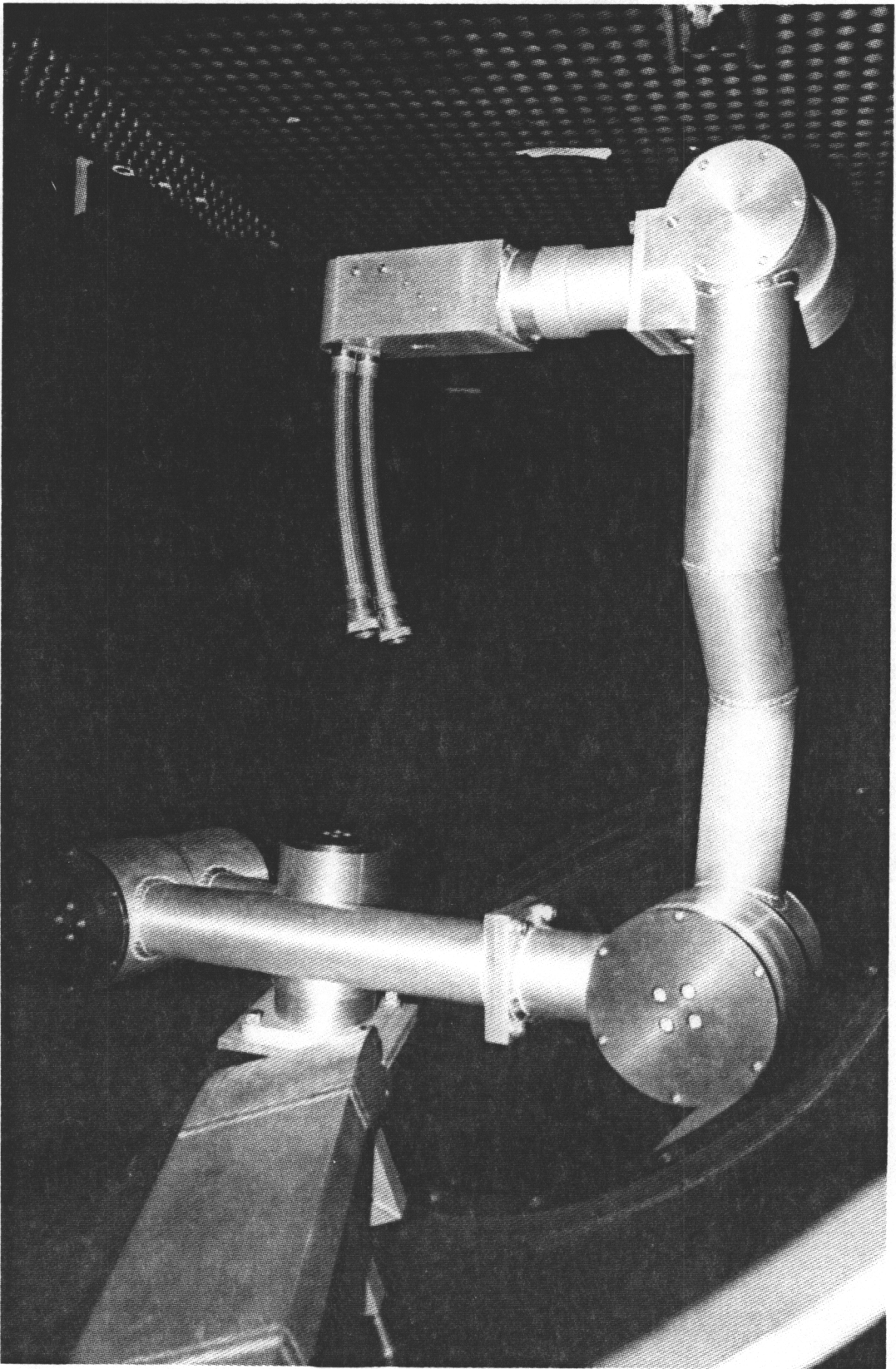

Figure 4.16: Prototype of The LAWS Manipulator

Chapter 5

Calibration of a LAWS Robot

The issues of particular importance to LAWS robots include installation procedures, obstacle avoidance and path planning, calibration and controls. This chapter addresses calibration of the LAWS robot presented in Chapter 4.

Roth, Mooring and Ravani in “An Overview of Robot Calibration” (1987) define robot calibration as “a process by which robot accuracy can be improved by modifying the robot positioning software rather than changing or altering the design system of the robot or its control system.” The procedures described here do not conform strictly to this definition, but include the physical correction of parameters when it is found to be beneficial to the operation of the robot. The procedure will hereafter be referred to as calibration.

The purpose of robot calibration is to correct or compensate for robot kinematic inaccuracies. In general, positioning inaccuracies are caused by such factors as link parameter errors, wear, thermal effects, flexibility of the links and gear train, encoder resolution errors, gear backlash, control errors and errors associated with relating the theoretical robot coordinate frame to the world coordinate frame. In the case of the LAWS robot application described here, the manipulators are built and maintained within very strict tolerances. Compensation and correction for parameters within

the manipulator itself is termed intrinsic calibration. Because the LAWS robot is installed and deployed for operation at various worksites, it is critical to determine the location and orientation of the robot coordinate frame in relation to the world coordinate frame. This procedure is termed extrinsic calibration. Both forms of calibration are critical to the operation of the LAWS robot.

Roth, Mooring and Ravani describe the calibration process at any level as consisting of four steps. In Step 1 – Modeling, a suitable functional relationship between the real system and the computational system is developed. In Step 2 – Measurement, data is collected from the actual robot that relate the input of the model to the output. Step 3 – Identification involves the mathematical process of using the data collected to identify the coefficients in the model. In Step 4 – Correction, the new model is implemented in the position control software. For the purposes of this work, the correction step will also include physical correction of parameters when desirable.

5.1 Intrinsic Calibration

Intrinsic calibration of the robot is performed after the manipulator has been assembled, during routine maintenance between every deployment, and after installation into the bowl. Intrinsic calibration involves the determination and correction of the kinematic parameters described by the Denavit-Hartenburg (D-H) notation (*Craig, 1989*). Every link has two parameters, link length l and twist angle α . Every joint has two parameters, offset d and rotation θ . The manipulator design described in the previous chapters has five coordinate axes attached as shown in Figure 5.1. Following the D-H notation leads to the generation of the manipulator parameters given in Table 5.1.

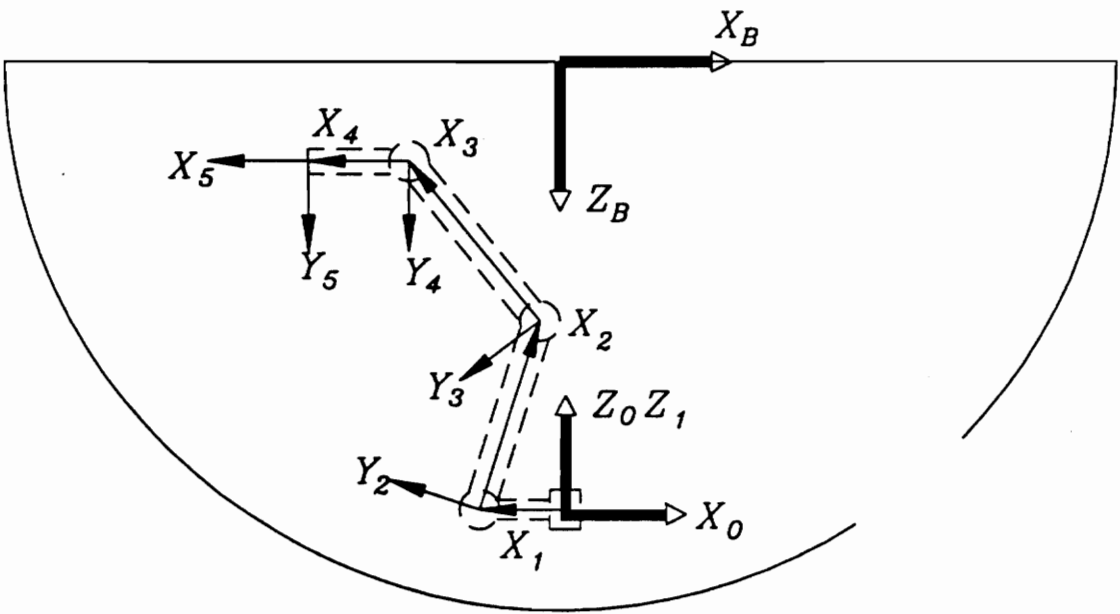

Figure 5.1: Kinematic Model of Manipulator Showing Attached Coordinate Axes

Table 5.1: Denavit-Hartenburg Parameters for the Manipulator

i	α_{i-1}	l_{i-1}	d_i	θ_i
1	0	0	$d_1 (0)$	θ_1
2	$\alpha_1 (90)$	l_1	$d_2 (0)$	θ_2
3	$\alpha_2 (0)$	l_2	$d_3 (0)$	θ_3
4	$\alpha_3 (0)$	l_3	$d_4 (0)$	θ_4
5	$\alpha_4 (0)$	l_4	$d_5 (0)$	$\theta_5 (0)$

Note that α_0 and l_1 equal zero by definition. The intended values for the other α 's, d 's and θ_5 are indicated by the values in parentheses. Precise values for l_1 through l_4 must be determined, and the synchros (used for measuring joint angles) must be calibrated to precisely represent the values of the θ 's.

5.1.1 External Intrinsic Calibration

External intrinsic calibration describes the procedure which occurs outside of the bowl after assembly and during maintenance. This procedure verifies values for α 's and d 's and determines the precise values for l 's and θ 's. The measurement procedure involves installing the manipulator on a calibration fixture in a kinematically known configuration. The parameters are measured very precisely. Proper operation of the manipulator requires that these values must be kept within a very strict tolerance of the intended values. If the α 's and d 's are not within strict tolerance of the intended values, the manipulator must be reworked and physically corrected. This must be done because proper operation requires that the manipulator operate as a planar device beyond the first joint. The link lengths, l 's, are retained for use in the control code. The synchros are adjusted to read the correct absolute angular values.

5.1.2 Internal Intrinsic Calibration

Internal intrinsic calibration describes the procedure which occurs inside of the bowl after installation. This procedure assumes that the twist angles, α 's, and offsets, d 's, are correct. The external intrinsic calibration procedure also determined nominal values for the link lengths, l 's. The synchros have also been calibrated for proper absolute measurement of the joint angles. However, because errors may be introduced during transport and installation of the manipulator, the manipulator should be double-checked after installation. The procedure will determine gross changes in link lengths and compensate for small deviations in joint angle measurements.

Modeling

With the manipulator modeled as a planar device, the manipulator kinematic model described in Chapter 4 is utilized. The calibration procedure requires that the tool tip touch a known location in the manipulator base coordinate frame as shown in Figure 5.2. The calibration probe is designed to constrain the tool tip to a known orientation by assuring that the probe face is flush with the reference location. The configuration of the manipulator can be described kinematically as shown in Figure 5.3.

The position of the tool tip is described in complex polar form as:

$$l_{ref}e^{i\theta_{ref}} = l_1 + l_2e^{i\theta_2} + l_3e^{i(\theta_2+\theta_3)} + l_4e^{i(\theta_2+\theta_3+\theta_4)} \quad (5.1)$$

which can be expanded as

$$l_{ref}c\theta_{ref} = l_1 + l_2c\theta_2 + l_3c(\theta_2 + \theta_3) + l_4c(\theta_2 + \theta_3 + \theta_4) \quad (5.2)$$

$$l_{ref}s\theta_{ref} = l_2s\theta_2 + l_3s(\theta_2 + \theta_3) + l_4s(\theta_2 + \theta_3 + \theta_4) \quad (5.3)$$

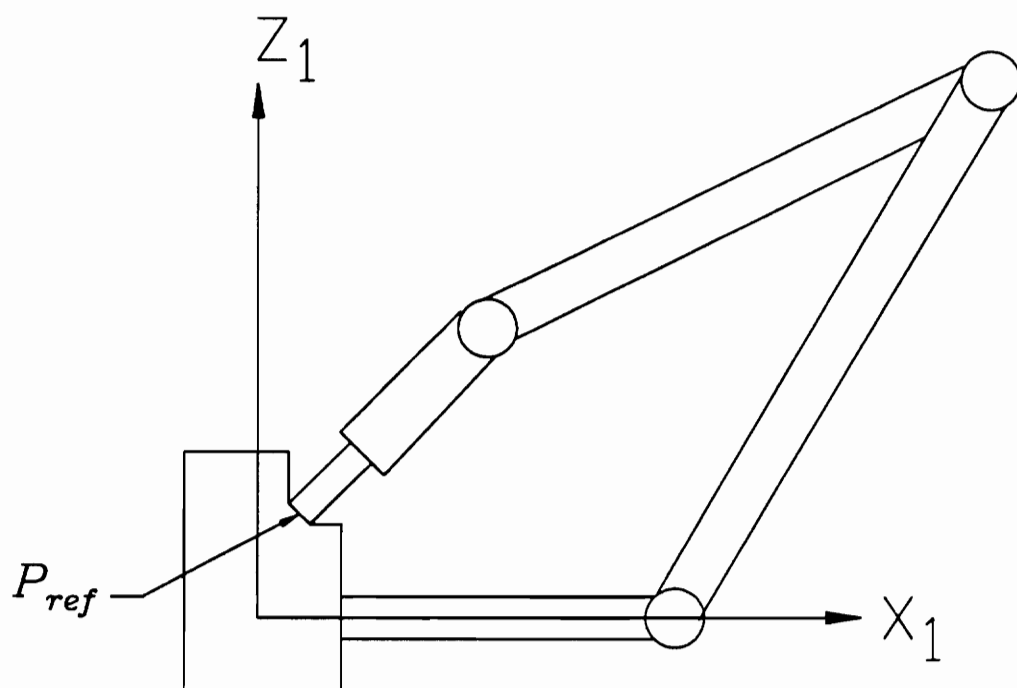

Figure 5.2: Manipulator Configuration For Intrinsic Calibration

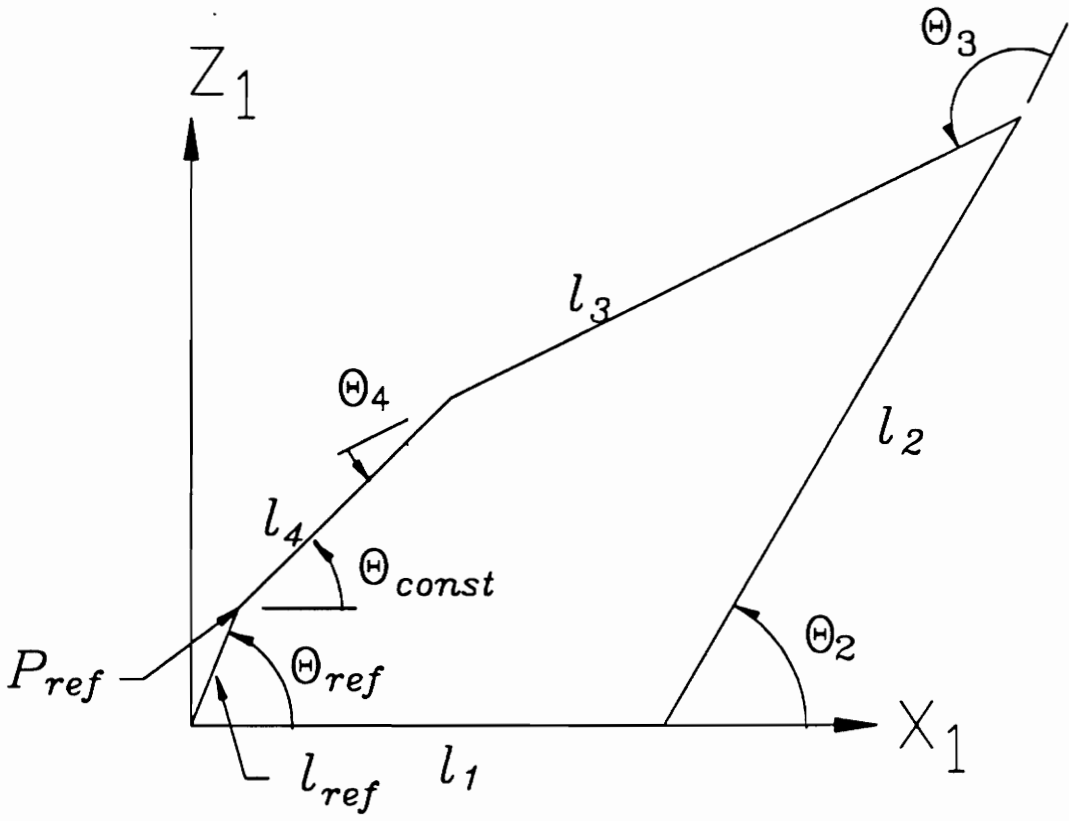

Figure 5.3: Kinematic Representation of the Calibration Configuration

Constraining the orientation of the tool tip creates the additional equation:

$$\theta_2 + \theta_3 + \theta_4 = \theta_{const} \quad (5.4)$$

where θ_{const} is the angle at which the probe is constrained.

This formulation produces three equations and three unknowns (θ_2 , θ_3 , and θ_4).

Measurement

The measurement involves placing the tool tip at the location shown in Figure 5.2 such that the sensors indicate contact. The synchro values for each of the joint angles are read for this configuration.

Identification

Solution of equations 5.2, 5.3 and 5.4 follows the same method as presented in Chapter 4 for the inverse kinematics of the manipulator model. The method produces theoretically correct, or nominal, values for θ_2 , θ_3 and θ_4 .

Correction

Correction is performed by comparing the measured values and the nominal values produced by the identification process.

$$\Delta\theta = \theta_{measured} - \theta_{nominal} \quad (5.5)$$

If the $\Delta\theta$'s are greater than an allowable tolerance, the manipulator must be removed and checked for errors in the Denavit-Hartenburg parameters. Otherwise, the $\Delta\theta$'s must be entered into the control software to compensate for the deviation.

Note that the procedure for internal intrinsic calibration does not include calibration of θ_1 . Figure 5.1 indicates that Z_B and Z_O are collinear. Therefore, the calibration of θ_1 can be included with the extrinsic calibration.

5.2 Extrinsic Calibration

The objective of extrinsic calibration is to determine the location and orientation of the manipulator base coordinate frame relative to the bowl frame, i.e. to find the transformation ${}^B_O T$. Figure 5.4 illustrating these two coordinate systems is reproduced from Figure 4.10 for convenience. Figure 5.5 shows the relationship between the transformations involved. Finding the base frame relative to the bowl frame requires that the tool position must be known relative to the base. Thus, accurate intrinsic calibration is essential before extrinsic calibration can be attempted. It is also essential to determine the location of the tool relative to the bowl coordinate frame, ${}^B P$. From this information, the position and orientation of the base frame can be found relative to the bowl frame.

5.2.1 Modeling

As described previously, the manipulator coordinate frame relates to the environment coordinate frame through the transformation matrix:

$${}^B_O T = \begin{bmatrix} c\alpha c\beta & c\alpha s\beta s\gamma - s\alpha c\gamma & c\alpha s\beta c\gamma + s\alpha s\gamma & {}^B M_x \\ s\alpha c\beta & s\alpha s\beta s\gamma + c\alpha c\gamma & s\alpha s\beta c\gamma - c\alpha s\gamma & {}^B M_y \\ -s\beta & c\beta s\gamma & c\beta c\gamma & {}^B M_z \\ 0 & 0 & 0 & 1 \end{bmatrix} \quad (5.6)$$

where

- γ - rotation about X_B
- β - rotation about Y_B
- α - rotation about Z_B

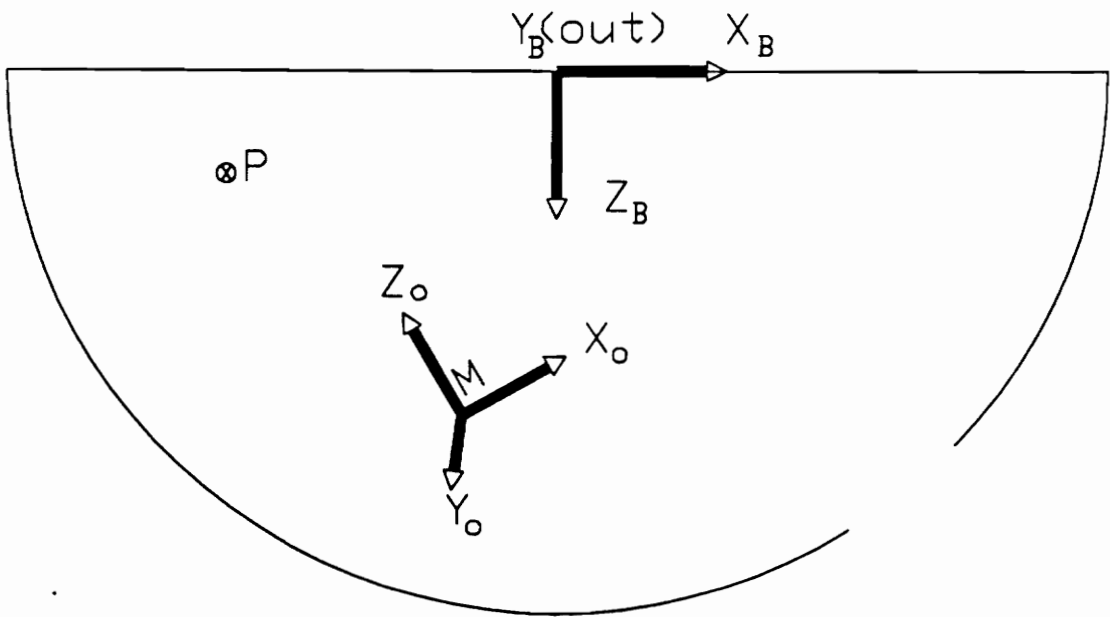

Figure 5.4: Environment and Manipulator Coordinate Systems Prior to Calibration

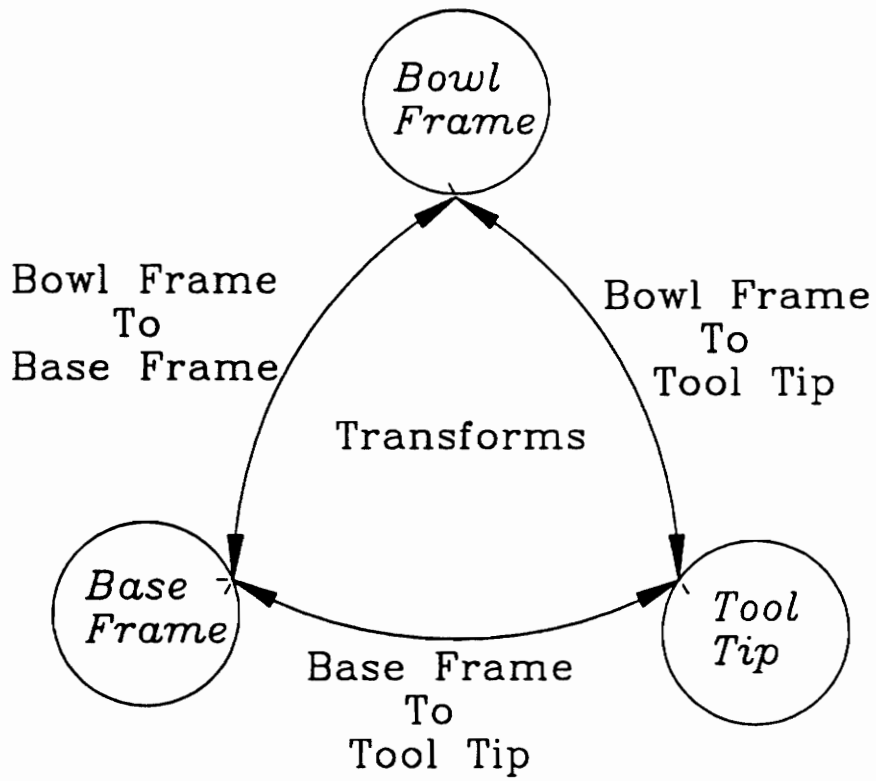

Figure 5.5: Correlation Between Coordinate Frame Transformations

The tool tip position in the base frame, ${}^O P$, is assumed to be known. The location of the tool tip in the bowl coordinate system is represented by the equation:

$${}^B P = {}_O^B T {}^O P$$

or

$$\begin{bmatrix} {}^B P_X \\ {}^B P_Y \\ {}^B P_Z \\ 1 \end{bmatrix} = \begin{bmatrix} c\alpha c\beta & c\alpha s\beta s\gamma - s\alpha c\gamma & c\alpha s\beta c\gamma + s\alpha s\gamma & {}^B M_x \\ s\alpha c\beta & s\alpha s\beta s\gamma + c\alpha c\gamma & s\alpha s\beta c\gamma - c\alpha s\gamma & {}^B M_y \\ -s\beta & c\beta s\gamma & c\beta c\gamma & {}^B M_z \\ 0 & 0 & 0 & 1 \end{bmatrix} \begin{bmatrix} {}^O P_X \\ {}^O P_Y \\ {}^O P_Z \\ 1 \end{bmatrix} \quad (5.7)$$

In these equations, α , β , γ , ${}^B M_x$, ${}^B M_y$ and ${}^B M_z$ are all unknown and must be found as part of the calibration process. Inspection of the transformation equation indicates that the extrinsic calibration is best completed in two parts namely (1) Finding β , γ , and ${}^B M_z$, and (2) Finding α , ${}^B M_x$, and ${}^B M_y$.

5.2.2 Finding β , γ , and ${}^B M_z$

Measurement

If the manipulator tool is touched to the tubesheet at three distinct points, the Z component of the transform equation 5.7 can be written three times to solve for β , γ and ${}^B M_z$, since ${}^B P_Z = 0$ at the tubesheet. Recall that ${}^O P$ is known through the intrinsic calibration.

Identification

Taking only the Z component of the transformation equation 5.7 gives:

$${}^B P_Z = -{}^O P_X s\beta + {}^O P_Y c\beta s\gamma + {}^O P_Z c\beta c\gamma + {}^B M_Z \quad (5.8)$$

where the unknowns are β , γ , and ${}^B M_Z$.

The three equations resulting from touching three distinct points P_1, P_2 and P_3 are:

$$0 = -{}^O P_{X1} s\beta + {}^O P_{Y1} c\beta s\gamma + {}^O P_{Z1} c\beta c\gamma + {}^B M_Z \quad (5.9)$$

$$0 = -{}^O P_{X2} s\beta + {}^O P_{Y2} c\beta s\gamma + {}^O P_{Z2} c\beta c\gamma + {}^B M_Z \quad (5.10)$$

$$0 = -{}^O P_{X3} s\beta + {}^O P_{Y3} c\beta s\gamma + {}^O P_{Z3} c\beta c\gamma + {}^B M_Z \quad (5.11)$$

The closed-form solution of these three equations with three unknowns proceeds as follows:

1. Eliminate M by subtracting equations 5.10 and 5.11 from 5.9 to yield:

$$0 = -({}^O P_{X1} - {}^O P_{X2})s\beta + ({}^O P_{Y1} - {}^O P_{Y2})c\beta s\gamma + ({}^O P_{Z1} - {}^O P_{Z2})c\beta c\gamma \quad (5.12)$$

$$0 = -({}^O P_{X1} - {}^O P_{X3})s\beta + ({}^O P_{Y1} - {}^O P_{Y3})c\beta s\gamma + ({}^O P_{Z1} - {}^O P_{Z3})c\beta c\gamma \quad (5.13)$$

2. Divide equations 5.12 and 5.13 through by $c\beta$, and introduce the notation

${}^O P_{X12} = {}^O P_{X1} - {}^O P_{X2}$, ${}^O P_{X13} = {}^O P_{X1} - {}^O P_{X3}$, to give:

$$0 = -{}^O P_{X12} \tan\beta + {}^O P_{Y12} s\gamma + {}^O P_{Z12} c\gamma \quad (5.14)$$

$$0 = -{}^O P_{X13} \tan\beta + {}^O P_{Y13} s\gamma + {}^O P_{Z13} c\gamma \quad (5.15)$$

3. Multiply equation 5.14 by ${}^O P_{X13}$ and equation 5.15 by ${}^O P_{X12}$, and then sub-

tract equation 5.15 from equation 5.14 to yield:

$$0 = ({}^o P_{Y12} {}^o P_{X13} - {}^o P_{Y13} {}^o P_{X12})s\gamma + ({}^o P_{Z12} {}^o P_{X13} - {}^o P_{Z13} {}^o P_{X12})c\gamma \quad (5.16)$$

or

$$0 = As\gamma + Bc\gamma$$

where

$$A = {}^o P_{Y12} {}^o P_{X13} - {}^o P_{Y13} {}^o P_{X12}$$

$$B = {}^o P_{Z12} {}^o P_{X13} - {}^o P_{Z13} {}^o P_{X12}$$

4. Solve for gamma.

$$-As\gamma = Bc\gamma$$

$$\frac{s\gamma}{c\gamma} = \frac{-B}{A}$$

$$\tan\gamma = -B/A$$

$$\gamma = \arctan(-B/A) \quad (5.17)$$

5. Back substitution of γ into equation 5.14 or 5.15 gives a value for β .

6. ${}^B M_Z$ can be found by substituting values for γ and β back into equation 5.9, 5.10 or 5.11.

Correction

Proper operation of the manipulator requires that the mezzanine base be level. Through actuation, the mezzanine base will be leveled by rotating about X_B by $180 - \gamma$ and rotating about Y_B by $-\beta$. The value for ${}^B M_Z$ in the control software will be corrected to the calibrated value.

5.2.3 Finding α , ${}^B M_X$, and ${}^B M_Y$

The location of the tubes on the tubesheet are known precisely for each bowl. It is necessary to determine the center location of the tube. This can be achieved by inserting a probe into the tube and “touching off” at three points on the tube wall. The three points can be used to determine the tube center coordinates. Thus, finding a tube center precisely determines a vector ${}^O P$. Assuming that the previous correction procedure has been performed, $\beta = 0$ and $\gamma = 180^\circ$. The transformation equation 5.7 can be written explicitly for a known ${}^B P$ to obtain:

$${}^B P_X = {}^O P_X c\alpha + {}^O P_Y s\alpha + {}^B M_X \quad (5.18)$$

$${}^B P_Y = {}^O P_X s\alpha - {}^O P_Y c\alpha + {}^B M_Y \quad (5.19)$$

This produces two equations and three unknowns (α , ${}^B M_X$, and ${}^B M_Y$). Therefore the tool must be placed at two locations to solve for the unknowns.

Measurement

Measurement involves positioning the tool at two tube locations whose location is known in the bowl coordinate frame. The identification process is greatly simplified if two tubes with equivalent X coordinates are chosen. The locations of the tool in the manipulator frame ${}^O P$ are then known accurately from the intrinsic calibration procedure.

Identification

Equations 5.18 and 5.19 can be expressed for the two tube locations as:

$${}^B P_{X1} = {}^O P_{X1}c\alpha + {}^O P_{Y1}s\alpha + {}^B M_X \quad (5.20)$$

$${}^B P_{Y1} = {}^O P_{X1}s\alpha - {}^O P_{Y1}c\alpha + {}^B M_Y \quad (5.21)$$

$${}^B P_{X2} = {}^O P_{X2}c\alpha + {}^O P_{Y2}s\alpha + {}^B M_X \quad (5.22)$$

$${}^B P_{Y2} = {}^O P_{X2}s\alpha - {}^O P_{Y2}c\alpha + {}^B M_Y \quad (5.23)$$

Any three of these equations can be used to solve for α , ${}^B M_X$ and ${}^B M_Y$ using the following procedure:

1. Subtract equation 5.22 from 5.20 to eliminate ${}^B M_X$.

$${}^B P_{X1} - {}^B P_{X2} = ({}^O P_{X1} - {}^O P_{X2})c\alpha + ({}^O P_{Y1} - {}^O P_{Y2})s\alpha \quad (5.24)$$

2. If ${}^B P_{X1} = {}^B P_{X2}$, i.e. the tubes have identical X coordinates, equation 5.24 simplifies to

$$0 = ({}^O P_{X1} - {}^O P_{X2})c\alpha + ({}^O P_{Y1} - {}^O P_{Y2})s\alpha$$

or

$$-({}^O P_{X1} - {}^O P_{X2})c\alpha = ({}^O P_{Y1} - {}^O P_{Y2})s\alpha$$

and

$$\tan\alpha = \frac{-({}^O P_{X1} - {}^O P_{X2})}{{}^O P_{Y1} - {}^O P_{Y2}}$$

Solving explicitly for α yields

$$\alpha = \text{atan} \left(\frac{-({}^O P_{X1} - {}^O P_{X2})}{{}^O P_{Y1} - {}^O P_{Y2}} \right) \quad (5.25)$$

3. Back substitute the value for α into equation 5.20 or 5.22 to solve for ${}^B M_X$.
4. Back substitute the value for α into equation 5.21 or 5.23 to solve for ${}^B M_Y$.

Correction

Correction for this part of the extrinsic calibration is performed by correcting the nominal values for ${}^B M_X$ and ${}^B M_Y$ in the controls software. Because α represents the rotation about the Z axis, it can be corrected by adjusting the “home” position of θ_1 .

Once the calibration procedure is complete the robot should function with the desired accuracy. Calibration procedures are intended to correct or compensate for small errors. However, if the robot cannot be calibrated properly, the manipulator must be removed and inspected for gross errors.

Chapter 6

Conclusions and Recommendations

LAWS robots have been shown to possess distinct attributes and require a particular approach for conceptual design, modeling and analysis. LAWS robots must operate in pre-existing, unalterable environments that often restrict their movements. The robot is often inaccessible during operation and cannot be viewed directly. The operational tasks require that the robot be portable to difficult-to-reach worksites where it is installed and later removed. Because LAWS robots often cannot be installed precisely, calibration techniques must be employed to improve the robot's operational performance.

When confronted with a problem that can be identified as a LAWS robot application, the designer should consider several particular issues. Foremost, the designer must consider the need for the manipulator to access the environment workspace through a constrictive portal. The manipulator size and shape restrictions imposed by this constraint coupled with the installation requirements lead to the development of five classes of LAWS robots. The five classes of LAWS robots have been illustrated in Figure 3.2 and demonstrate the potential types of robots for a LAWS robot application.

The designer must also consider the effects of the constrained environment on the possible workspace of the manipulator. Figures 3.3, 3.4, 3.5 and 3.6 illustrate the reduced potential workspace for a manipulator in a constrained environment. The target workspace must be contained within the limited access workspace of the manipulator.

Determining whether or not a manipulator design meets the workspace requirements becomes increasingly more complicated as the number of degrees of freedom in the manipulator increases. Therefore, an accurate mathematical model of both the manipulator and the environment must be developed. A model for the example LAWS robot design has been described in detail.

Analysis often requires an exhaustive search of the manipulator's ability to reach the target workspace while operating within the boundaries of the environment. For a given set of manipulator design parameters, the analysis must be performed to cover the target workspace. If analysis determines that there is not an acceptable solution for any location in the target space, the manipulator design parameters must be changed.

The iterative nature of the analysis and optimization procedure requires the use of some form of computer algorithm. For the example LAWS robot, a LISP program was written utilizing the Autocad environment. The program was used to determine the design parameters of the robot.

Because LAWS robots are often installed and deployed for operation at various worksites, it is critical to determine the location and orientation for the robot coordinate frame in relation to the world coordinate frame. This procedure is termed extrinsic calibration. Compensation and correction of errors in the kinematic parameters within the manipulator itself is termed intrinsic calibration. Both forms

of calibration are critical to the operation of the LAWS robot. Details of these calibration techniques have been presented for the example LAWS robot design.

The calibration procedure described required that the manipulator make physical contact with known locations on the environment boundary. It may prove more advantageous to utilize vision techniques for the calibration. Tsai (1987) describes a vision calibration technique "aimed at efficient computation of camera external position and orientation relative to [the] object reference coordinate system ...". Further research must be conducted to determine if this or another vision technique could be utilized for LAWS robot calibration.

Other areas for future work concern the implementation of LAWS robots. Path planning and obstacle avoidance techniques must be developed to avoid collision of the manipulator with the environment boundary or internal obstacles. Control strategies for LAWS robot applications must also be addressed.

Robotics technology has grown greatly in the past decade. Improvements in computer technology, sensing, actuation, and materials have assisted in freeing robots from the tethers of the manufacturing environment. Robots are being utilized more and more in the service industry. Applications for robots that can operate in limited access workspaces exist in the nuclear, construction, mining, and medical industries, among others. The further development of this technology would aid in the advancement of new frontiers of potential applications for LAWS robots.

References

1. Asimov, Isaac and K.A. Frenkel, *Robots, Machines in Man's Image*, Harmony Books, New York, 1985.
2. Burgos, Dhande, Reinholtz and Stulce, "Conceptual Design of a Variable Geometry Truss Crawling Machine," *Proceedings of 1990 Applied Mechanisms Conference*, Chicago, Illinois, 1990.
3. Chedmail, P. and P. H. Wenger, "Design and Positioning of a Robot in an Environment With Obstacles Using Optimal Research," *IEEE International Conference on Robotics and Automation*, 1989, pp. 1069-1074.
4. Craig, J.J., *Introduction To Robotics: Mechanics and Control*, Addison-Wesley, Reading, Massachusetts, 1989.
5. Cross, N., *Engineering Design Methods*, John Wiley and Sons, Chichester, 1989.
6. Denavit, J. and R.S. Hartenburg, "A Kinematic Notation For Lower-pair Mechanisms Based On Matrices," *ASME Journal of Applied Mechanisms*, June, 1955, pp. 215-221.
7. Earl, C.F. and J. Rooney, "Some Kinematic Structures For Robot Manipulator Designs," *Journal of Mechanisms, Transmissions, and Automation in Design*, Vol 105, March, 1983, pp. 15-22.
8. Erlandson, E.F., K.A. Kristy, S.J. Wu, D. Greer, P. Debear, and M. Dijkers, "Use of Robotic Arm in the Rehabilitation of Stroke," *Robots 13 Conference Proceedings*, Gaithersburg, Maryland, May, 1989, pp. 5-11 to 5-25.

9. Esterline, A., D.R. Riley and A.G. Erdman, "Design Theory and AI Implementations of Design Methodology," *NSF Engineering Design Research Conference*, University of Massachusetts, 1989, pp. 205-220.
10. Evans, J. and B. Krishnamurthy, "Creating Smart Robots for Hospitals," *Robots 13 Conference Proceedings*, Gaithersburg, Maryland, May, 1989, pp. 5-1 to 5-5.
11. Everett, L.J. and A.D. Suryodhadiprojo, "A Study of Kinematic Models For Forward Calibration of Manipulators," *Proceedings of the IEEE International Conference on Robotics and Automation*, April, 1988, pp. 798-800.
12. Groover, M.P., N.D. Perreira, C. Doydum, and R. Smith, "A Survey of Robotics Technology in Construction," *1989 World Conference on Robotics: The Next Five Years and Beyond*, Gaithersburg, Maryland, May 7-11, 1989, pp. 1-1 to 1-26.
13. Groover, M.P., *Industrial Robotics*, McGraw Hill, New York, 1986.
14. Hirose, S., "A Study of Design and Control of a Quadruped Walking Vehicle," *International Journal of Robotics Research*, V3, 1984, pp. 113-133.
15. Mabie, H. and C.F. Reinholtz, *Mechanisms and Dynamics of Machinery*, J. Wiley and Sons, New York, 1987.
16. Miles, G.L., N. Gross, and M. Maremont, "It's a Dirty Job, But Something's Gotta Do It," *Business Week*, August 20, 1990, pp. 92-97.
17. Mooring, B.W. and T.J. Pack, "Calibration Procedure For An Industrial

- Robot," *Proceedings of the International Conference on Robotics and Automation*, April, 1988, pp. 786-791.
18. Raibert, M.H., Brown, Jr., H.B., and Chepponis, M., "Experiments in Balance With a Three-D One-legged Hopping Machine," *International Journal of Robotics Research*, V3, No. 2, Summer, 1984, pp. 75-92.
 19. Roth, Z.S., B.W. Mooring, and B. Ravani, "An Overview of Robot Calibration," *IEEE Journal of Robotics and Automation*, RA-3 No. 5, October 1987, pp. 377-384.
 20. Sandor, G.N., "The Seven Stages of Engineering Design," *Mechanical Engineering*, April, 1964, pp. 21-25.
 21. Shaker, S.M., "Warrior Robots," *Robots 13 Conference Proceedings*, Gaithersburg, Maryland, May, 1989, pp. 5-35 to 5-48.
 22. Sullivan, J.M., "A Portable, Electric, Robotic System for Asbestos Removal," *Robots 13 Conference Proceedings*, Gaithersburg, Maryland, May, 1989, pp. 10-1 to 10-9.
 23. Tsai, C.K., H.D. McGee, S.K. Cheng, and H. Akeel, "Automated Calibration For An Industrial Scara Robot," *Proceedings of the International Robots and Vision Automation Conference*, June, 1990, pp. 4-42 to 4-55.
 24. Tsai, R.Y., "A Versatile Camera Calibration Technique for High-Accuracy 3D Machine Vision Metrology Using Off-the-Shelf TV Cameras and Lenses," *IEEE Journal of Robotics and Automation*, August, 1987, pp. 323-344.

25. Waldron, K.J., "Advances in Robot Mechanisms," *Proceedings of the International Robots and Vision Automation Conference*, June, 1990, pp. 11-1 to 11-10.
26. Waldron, K.J. and R.B. McGhee, "The Adaptive Suspension Vehicle," *IEEE Controls Systems Magazine*, V6, No.6, December, 1986, pp. 7-12.
27. Waldron, M.B., K.J. Waldron and L.T. Herren, "Empirical Study of Constraints Which Direct Design Decisions in Conceptual Mechanical Design," *NSF Design Theory and Methodology Conference*, University of Massachusetts, June, 1989 pp 15-30.
28. Wiercienski, W. and A.R. Leek, "Feasibility of Robotic Cleaning of the Undersides of Toronto Subway Cars," *39th IEEE Vehicular Technology Conference*, San Francisco, California, 1989, pp. 884-887.
29. Whitaker, W.L., "Field Robotics: A National Challenge, A National Opportunity," *Proceedings of the International Robots and Vision Automation Conference*, Detroit, Michigan, June 5-7, 1990, pp. 7-50 to 7-65.
30. Yuh, J., "Overview of Intelligent Systems for Underwater Robotic Vehicles," *Robots 13 Conference Proceedings*, Gaithersburg, Maryland, May, 1989, pp. 6-15 to 6-23.
31. Ziegert, J. and P. Datsoris, "Basic Considerations for Robot Calibration," *IEEE International Conference on Robotics and Automation*, April, 1988, pp. 932-938.

Vita

Steven B. Shooter was born in Woodbury, New Jersey on November 6, 1965. He earned a bachelors degree in mechanical engineering from Virginia Polytechnic Institute and State University in May of 1988. He then worked as a Process Engineer for CBS Records/Sony Corporation where he supported the start-up of a compact disc plant. Steve returned to VPI&SU in the fall of 1989 to pursue a masters of science degree. He plans to continue doctoral studies in mechanical engineering with emphasis on robotics and design methods.

Steven B Shooter