

Building Life Cycles

An Exploration of a Building's
Transformation From One Life Into the Next

Carlo Go

Thesis submitted to the faculty of the Virginia Polytechnic Institute and State University
in partial fulfillment of the requirements for the degree of

Masters of Architecture in Architecture

Marcia Feuerstein

Paul Emmons

Jaan Holt

September 22, 2010

Washington-Alexandria Architecture Center
Alexandria, VA

Keywords: disassembly, transformation, mixed-use, end-of-life, adaptive re-use



abstract

'Nothing endures but change' - Heraclitus

Buildings are designed and built to house a specific program for a set period of time. The end of a building's life marks a change in its use. In today's building practices, some building owners opt to demolish an entire building prior to constructing a new one. Unfortunately, this world-wide attitude results in the production of millions of tons of waste every year and is not an ecologically sustainable practice.

However, as green building methods become more valued in today's society, building owners and designers are becoming more conscious of buildings' end lives. Construction methods are increasingly involving concepts of designing for disassembly, wherein parts and materials can be easily taken apart for reuse or recycling. Such practices are vital in minimizing the unnecessary production of construction waste.

Everything on earth exhibits change. This thesis explores the development of a newly constructed building and its transformation at the end of its life into a new building. The project consists of two designs; the program of the first was predetermined while the program of the second was chosen by the committee at the concluding stage of the first design.

This thesis seeks to develop a position on architectural design and construction methods that acknowledges the fact that buildings are not permanent objects and that they will, at some point in time, change.

Left: A collage expressing the current state of construction practices; many new construction and adaptive reuse projects produce tons of waste that is disposed of in landfills.

acknowledgements

My work on this project would not be possible without the guidance of my committee, Marcia, Paul, and Jaan. It was through you all that I acquired a new way of looking at architecture. Thank you.

Thanks also to my family for being completely understanding and supportive of my endeavors.

Most importantly I'd like to thank my better half, Anshul, who has been my inspiration throughout this entire project. You are everything to me and I love you.

contents

abstract, ii
acknowledgements, iv
contents, vi

site, 2
disassembly, 3
precedents, 4

phase 1: Howard University's new hotel

process, 6
final drawings, 14
final renders, 22

phase 2: community college/center for arts

process, 32
final drawings, 38
final renders, 48

conclusion, 54

bibliography + image sources, 56

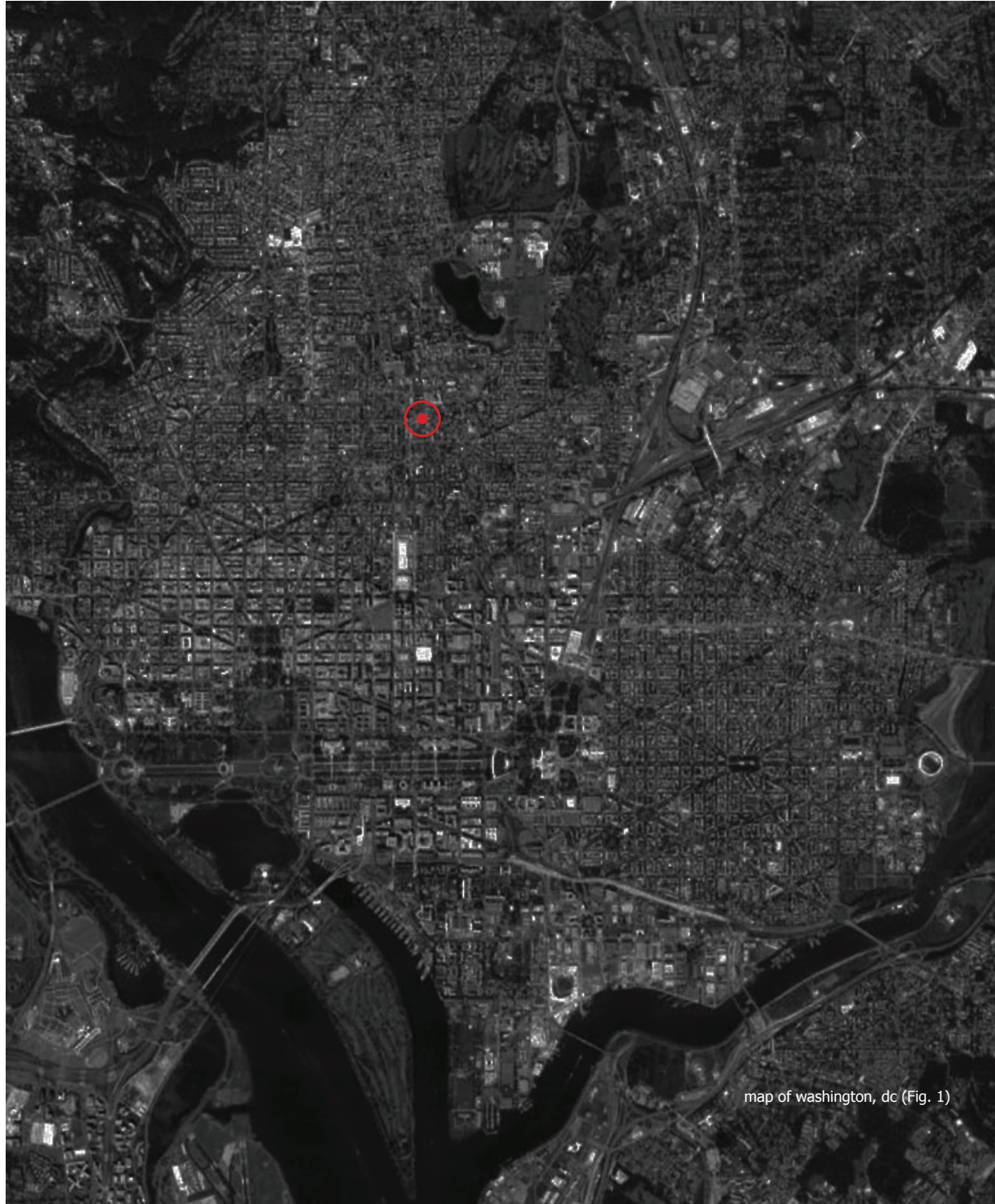

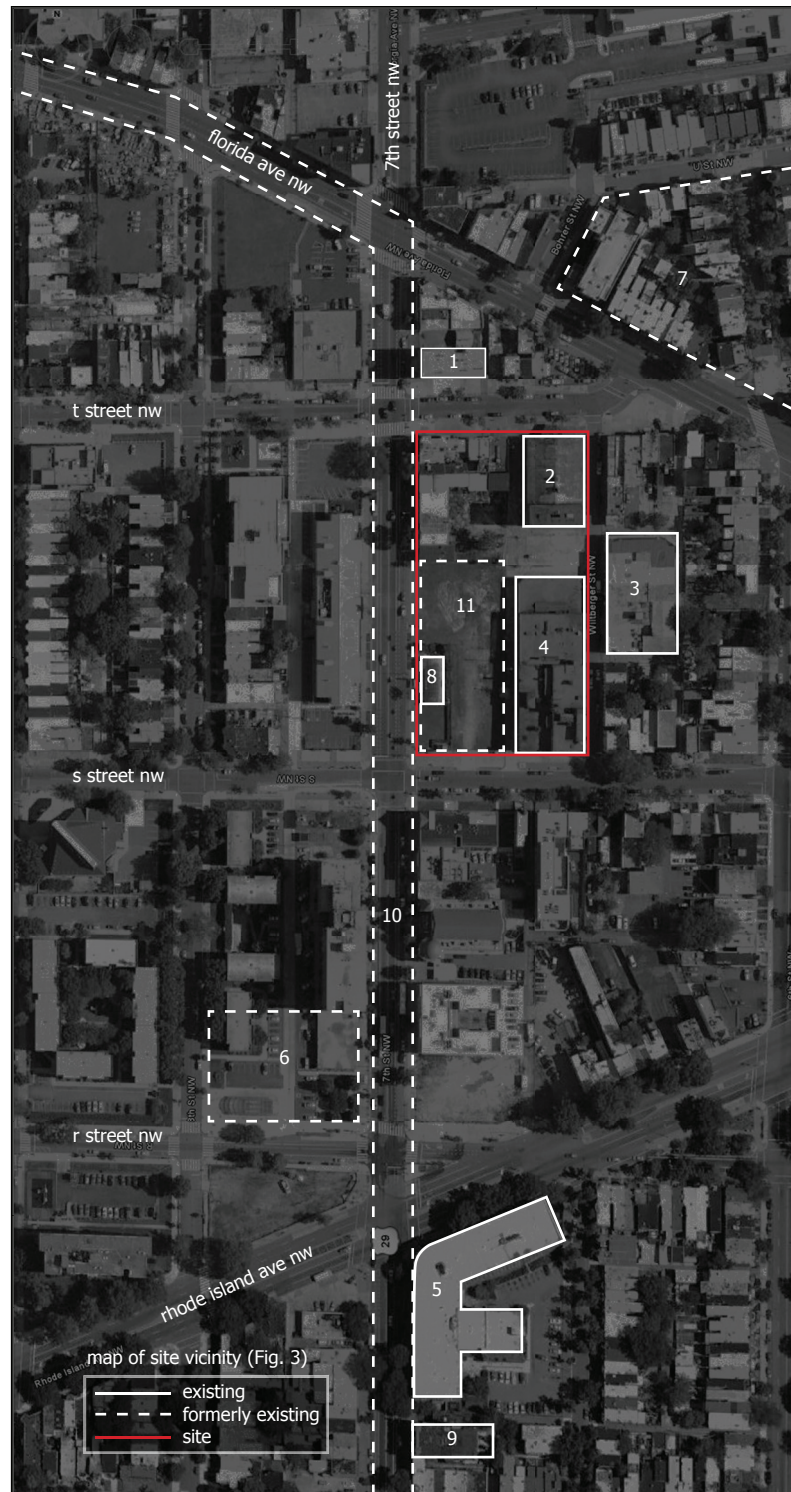

1/Dunbar Theater, built 1920



5/McKinley Technical School, built 1902



2/Howard Theater, built 1910



6/Manhattan Auto Showroom, built 1950 (Fig. 4)



3/Bakery Building, built 1891



7/Camp Campbell, built early Civil War (Fig. 5)



4/Wonder Bread Factory, built 1913



8/Shaw-Howard Univ. Metro, opened 1991

Not pictured:

9/Lafayette Apartments (built 1898)

10/7th Street Railway (built 1830)

11/Waxie Maxie's Music Store (built 1937)

site

The project began with the search for a location. As a growing metropolis with a rich history, Washington, DC houses many buildings that have changed over time. An ideal location for the site would have a number of such buildings within its immediate vicinity.

The chosen site is located north of downtown Washington, DC, within the boundaries of the historic Shaw neighborhood. In addition to the location of the Shaw/Howard University Metro Station, the site houses two well-known historic buildings within its boundaries - the Howard Theater, formerly an entertainment hotspot from 1910-1950's and currently undergoing restoration, and the famous Wonder Bread Factory, which underwent a series of additions throughout its lifetime and is slated for conversion into a mixed-use building featuring condos and retail spaces.

Other historically significant buildings within the site's vicinity are the Dunbar Theater, a famous venue for black entertainment during the 1920'-1950's which is now used as an office building with a retail ground floor; the Bakery Building, one of the first bakeries built in the area, the McKinley Technical High School, which was converted into senior housing in 1977; and the Lafayette Apartment Building, which was designed by George S. Cooper and is still used as apartments today.

Historically significant sites that are no longer in existence include the Manhattan Automobile Showroom, which was burned during the 1968 riots; Camp Campbell, a Civil War encampment originally located on the city boundary; Waxie Maxie's Music Store, which was demolished to build the entrance to the Shaw-Howard Metro Station; and the 7th Street Railway, one of the early street car lines in Northwest Washington, DC.

The site, rich in history, exhibits a record of constant change through the buildings in its vicinity. Such as site made a fitting location for a new building that is to be designed to also facilitate change throughout multiple life spans.

disassembly

Most buildings today are built with the idea of permanence in mind; wet construction methods such as cast in place concrete and masonry blocks bonded with mortar ensure strong, resilient structures intended to last a long time. But with rising costs of materials and labor, less expensive materials and construction methods are now used in order to maintain profit levels, resulting in lower-quality buildings with shorter life spans.

In large cities, business entities constantly acquire new properties to expand their operations, and more often than not, a property will include an existing building that may have lived several decades. Depending on the owner's plans and budget, the old building may most likely be demolished to make way for a new building that better fits the company's modern, cutting edge image.

Whether it be due to the shortening of building life spans or high turnover rate of property ownership, it is undeniable that today's society requires buildings to be more flexible in order to suit the changing demands of contemporary life.

As of now, the most dominant solution for replacing an unwanted building is to demolish it. It is cheap, fast, and easy. However, it will lead to a massive amount of waste as most demolished material is not reusable or recyclable.

In order to reduce the amount of waste that would inevitably be produced by buildings that will be replaced in the future, consideration of a new building's end life should be incorporated into the process of its design. Designing for disassembly is one way to achieve this.

By utilizing dry methods of construction such as bolted connections, a building can be built to last a considerable life span, yet be readily dismantled when it is required. As opposed to wet methods using techniques such as mortar and adhesives, which are much more difficult and in some cases impossible to separate, dry methods allow entire building components to be salvaged in sufficient condition to be reused or recycled.

The use of disassembly in architecture can be seen as early as in the work of Viollet-le-Duc, who sought to achieve lightness in a space using the least amount of material. To do this, he proposed to create large vaulted spaces using cast iron struts to support masonry roofs and ceilings. In his travels to China, Viollet-le-Duc also documented the potential of bamboo as a construction material that can be used in a disassemblable framing system for a vaulted space. In addition to environmental benefits, incorporating disassembly into the design of buildings can also introduce a new type of architectural aesthetic.

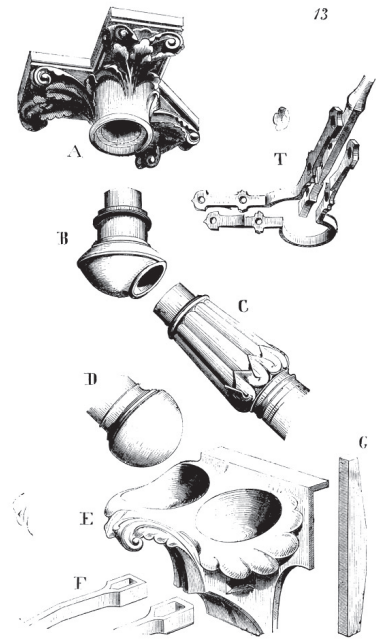

Fig. 6

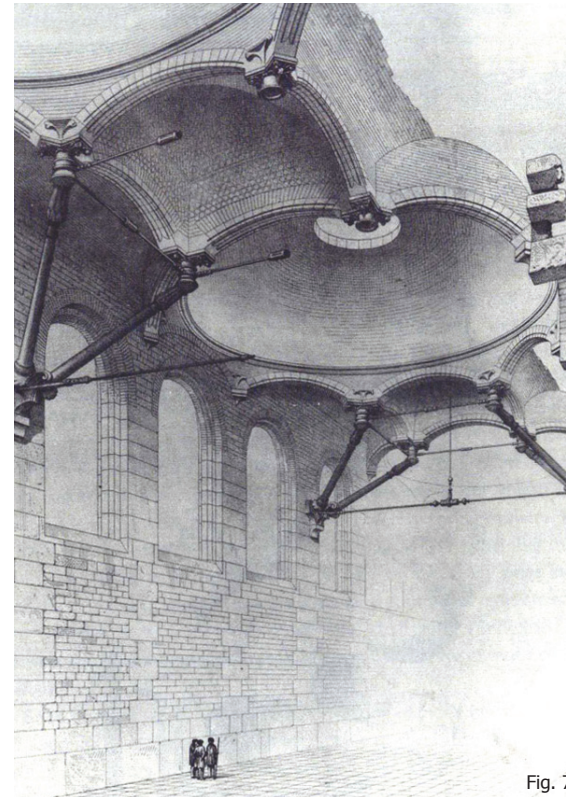

Fig. 7

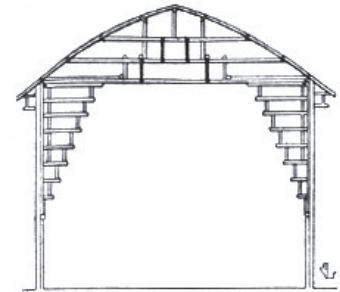

Fig. 8

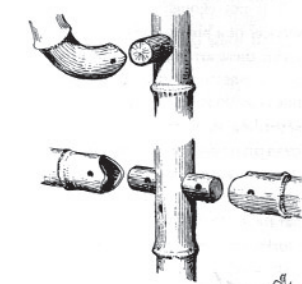

Fig. 9

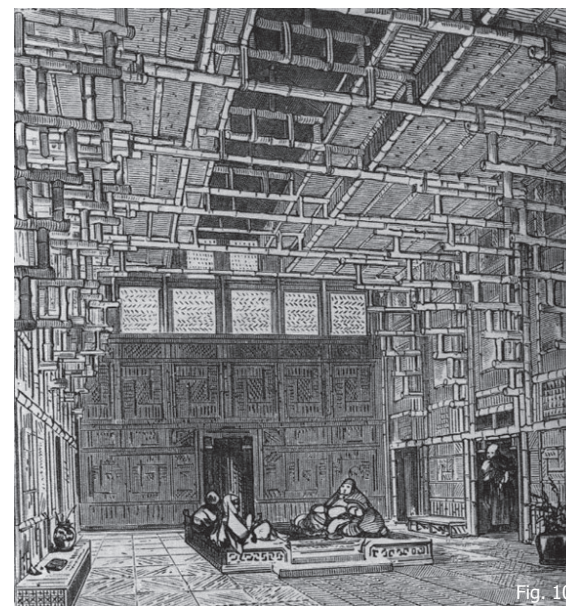

Fig. 10

Fig. 6, 7: Viollet-le-Duc's drawing of a great hall, with details of the supporting iron struts. **Fig. 8-10:** Viollet-le-Duc's drawing of the interior of a Chinese house with a diagram of the bamboo structure and detail of the framing connections.

Typical Building Lives Based on Typology

Category	Design Service Life	Examples
Temporary	up to 10 years	- Non-permanent construction buildings, sales offices - Temporary exhibition buildings
Medium Life	25 to 40 years	- Some industrial buildings - parking structures
Long Life	50 to 90 years	- Residential, commercial and office buildings - Health and educational buildings - Industrial buildings
Permanent	minimum 100 years	- Monumental buildings (ex. museums, art galleries, archives) - Heritage buildings

Source: Durability Implications, Canadian Architect

Evaluation of Connection Alternatives for Deconstruction

Type of Connection	Advantages	Disadvantages
Screw fixing	- easily removable	- limited use of both hole and screws - cost
Bolt fixing	- strong - can be reused a number of times	- can seize up, making removal difficult - cost
Nail fixing	- speed of construction - cost	- difficult to remove - removal usually destroys a key area of element - ends
Friction	- keeps construction element whole during removal	- relatively undeveloped type of connection - structural weakness
Mortar	- can be made to variety of lengths	- mostly cannot be reused, unless clay - strength of mix often over-specified making it difficult to separate bonded layers
Adhesives	- strong and efficient - deal with awkward joints - variety of strengths	- virtually impossible to separate bonded layers - cannot be easily recycled or reused
Rivet fixing	- speed of construction	- difficult to remove without destroying area of element - ends

Source: Design for Deconstruction - SEDA Design Guide for Scotland

Evaluation of Structural Alternatives for Deconstruction

Type of Structure	Advantages	Disadvantages
Masonry	- individual components break down into small, easily reusable units - solid mass can be recycled if monolithic - re-use does not dictate design	- blocks need soft binder to be reused which reduces strength - may include reinforcement which is harder to deconstruct - requires heavy machinery to break down solid mass - may have cross walls which compromise long term occupancy pattern options
Light Frame	- structurally efficient, allows for multiple occupancy patterns - easy to deconstruct into reusable elements if detailed appropriately (not concrete in-situ) - can be layered separately from cladding and insulation - can be factory made (not concrete in-situ)	- difficult to deconstruct unless framework is detailed with appropriate joints - notching, holes and binding with resins can reduce possibilities for reuse - depending on size and type can be manually or mechanically deconstructed
Panel System	- structurally efficient - factory-made-gives precision - all components can be built in to minimize waste	- requires mechanical deconstruction - materials are bound together and hard to separate - need for cross wall bracing reduces internal options
Post and Beam	- separates structure from envelope and other systems, can provide standardization of dimensions and homogenous materials - can reduce mass of structure to fewer linear components	- fewer larger members require mechanical deconstruction - less multi-functionality is possible such as combining structure with finish, etc.

Source: Design for Deconstruction - SEDA Design Guide for Scotland



Fig. 11



Fig. 12

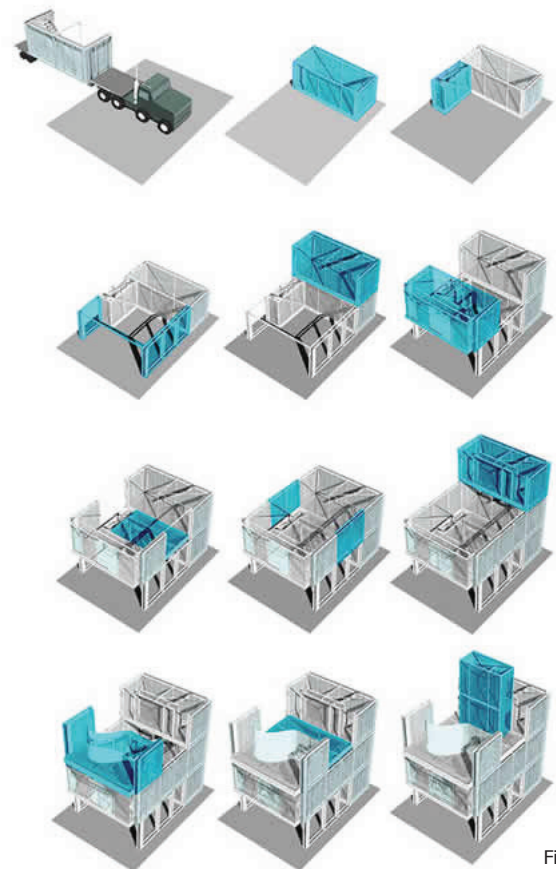

Fig. 13



Fig. 14



Fig. 15



Fig. 16



Fig. 17



Fig. 18



Fig. 19

precedents

Cellophane House, Kieran Timberlake: Commissioned by the Museum of Modern Art, the Cellophane House is a prefabricated structure comprised of aluminum framed modules that can be stacked and assembled to create homes of varying scales. Because of the modular construction and reversible bolted connections, the structure can be easily assembled in as little as 16 days. In addition, the house's walls feature an integrated system of green building functions including photovoltaic panels, a layer of solar heat and UV blocking film, and a ventilation cavity. With flexibility incorporated into the design, additional units can be connected and removed to create different forms, allowing the house to grow and shrink to accommodate a young couple or a family.

Nakagin Capsule Tower, Kisho Kurokawa: Built in 1972 in the Ginza district of Tokyo, the Capsule Tower is a rare built example of the Metabolist Movement, which envisioned cities as flexible and organic masses that constantly changed. Originally geared toward bachelor salarymen, the building comprised 140 apartment capsules attached to two concrete core towers. Each capsule was prefabricated off-site to include appliances, a bathroom and a bed before being shipped to the site and plugged in to the core. Theoretically, the capsules could be plugged in or removed whenever required in order to adapt to the requirements of the tenant. However, the building has fallen into disrepair with lack of regular maintenance. None of the capsules have been unplugged for repairs because the process has proven too expensive and today, the tower is under the risk of being razed. Nevertheless, it stands as an example of the innovation that would benefit our growing cities today - a dynamic urban model able to adapt to a fast-changing society.

R128 House, Werner Sobek: The R128 house is a prefabricated steel framed structure fully enclosed in glass and built of modular and lightweight parts that are entirely recyclable and emission free. Utilizing bolted joints and mortice-and-tenon joints, the structure can be easily assembled and dismantled. In addition, the house features a number of energy efficient systems. The glass panels are triple glazed using low-E glass with argon gas filled in between panels, significantly reducing temperature transfer from outside to inside. Photovoltaic panels on the roof provide electrical power. A specially designed geothermal heating system incorporates water filled panels in the roof that absorb solar heat in the summer, and in the winter the water is circulated through the ceiling to heat interior spaces. Using the least possible amount of materials and maximizing views overlooking the city of Stuttgart, the R128 House is an example of an energy efficient, environmentally friendly structure that is also comfortable to live in.

Fig. 11-13: Exterior view of Cellophane House, a module in construction, and diagram of assembly. **Fig. 14-16:** Exterior views of the Nakagin Capsule Tower and an interior of a capsule apartment. **Fig. 17-19:** Exterior and interior views of R128 House.

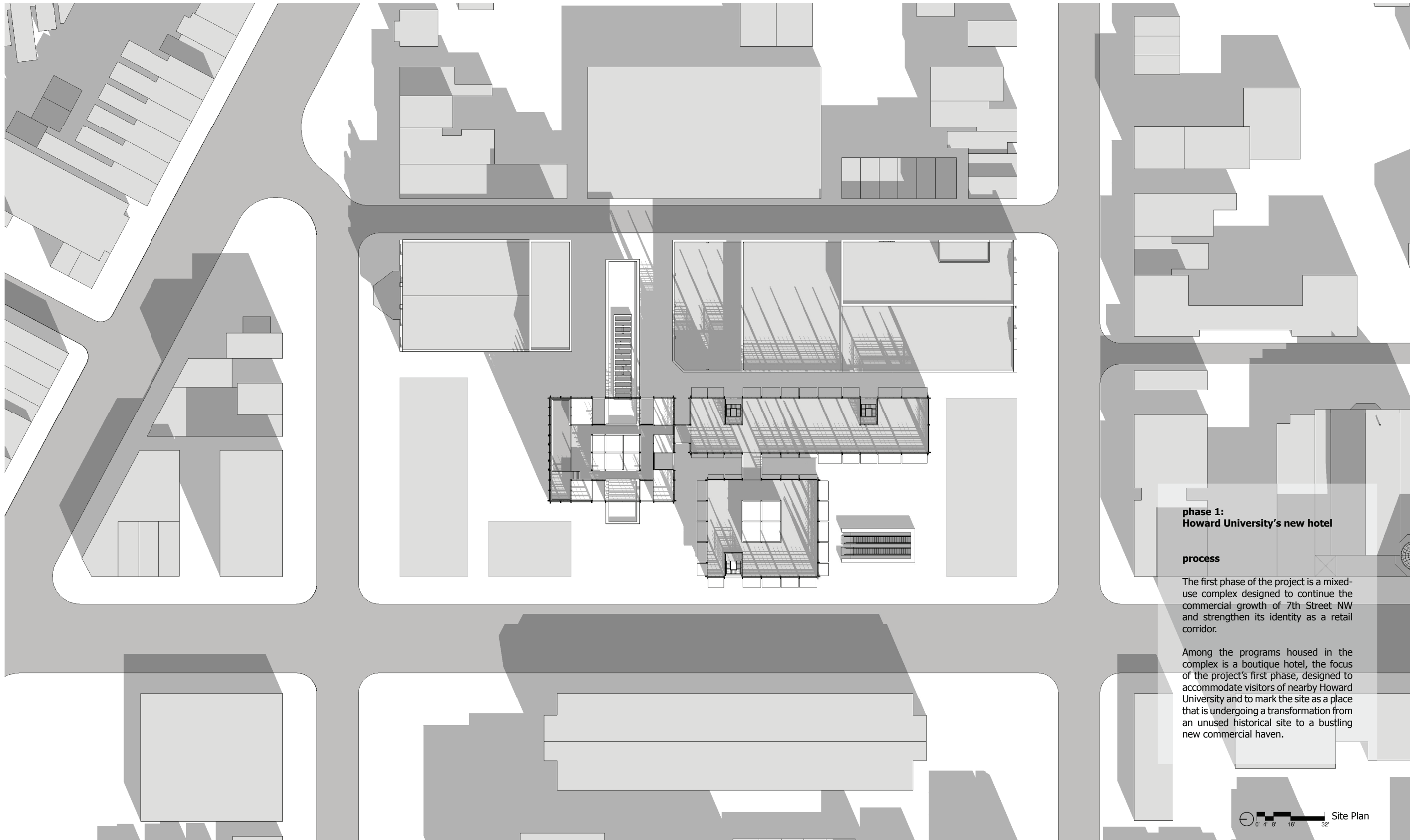

**phase 1:
Howard University's new hotel**

process

The first phase of the project is a mixed-use complex designed to continue the commercial growth of 7th Street NW and strengthen its identity as a retail corridor.

Among the programs housed in the complex is a boutique hotel, the focus of the project's first phase, designed to accommodate visitors of nearby Howard University and to mark the site as a place that is undergoing a transformation from an unused historical site to a bustling new commercial haven.

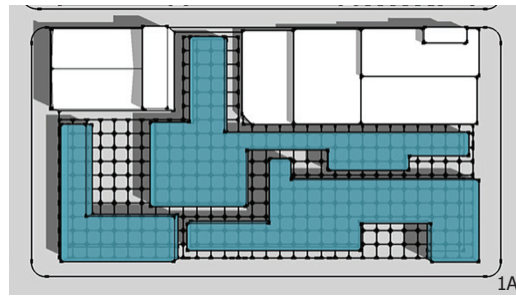

1A

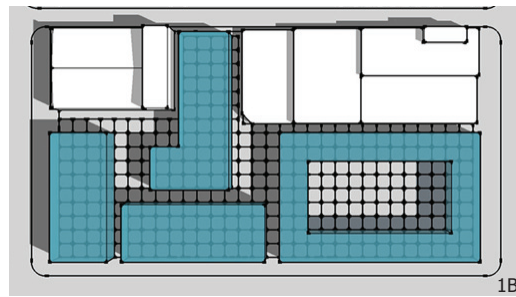

1B

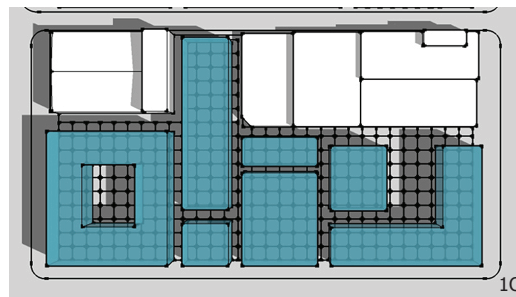

1C

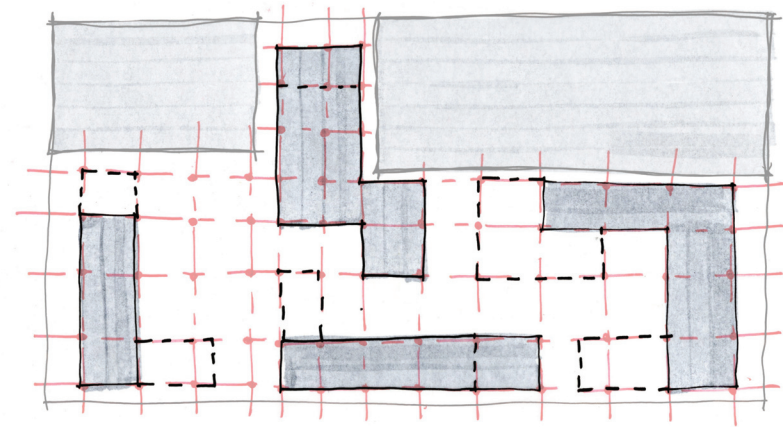

2

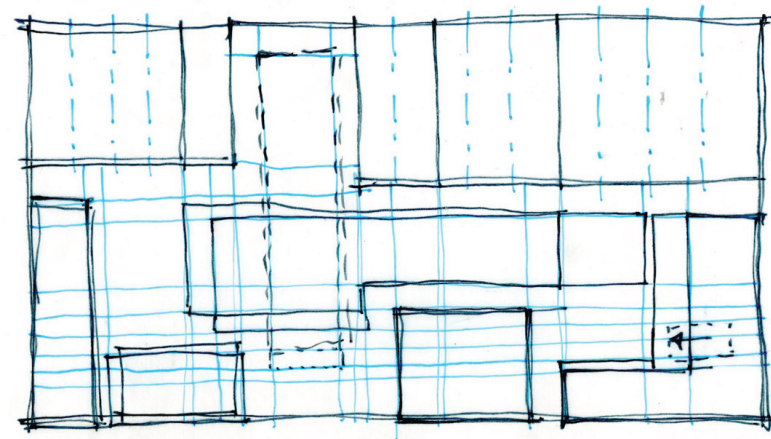

3

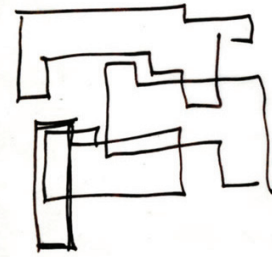

4A

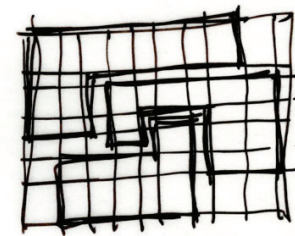

4B

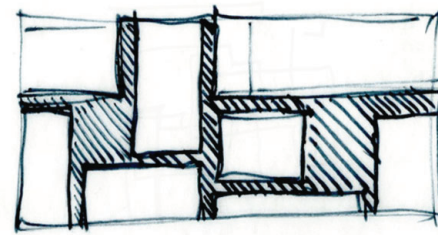

4C



4D

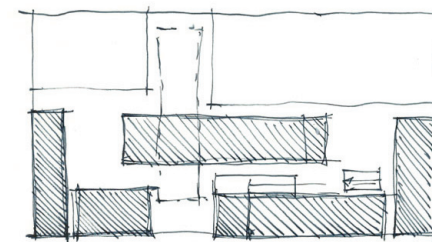

4E

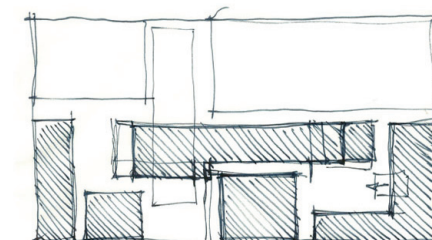

4F

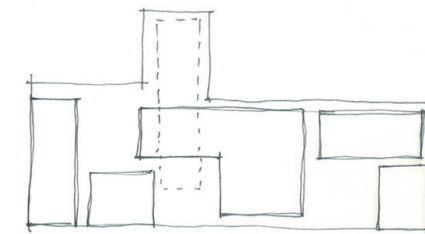

4G

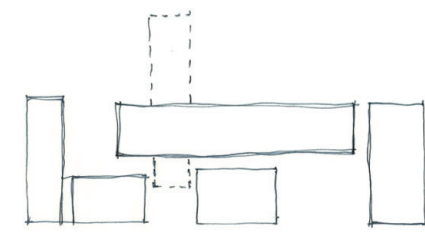

4H

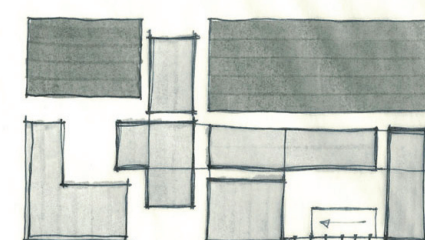

4I



5A

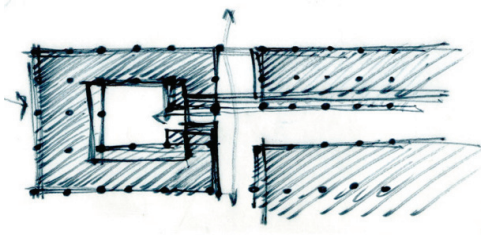

5B

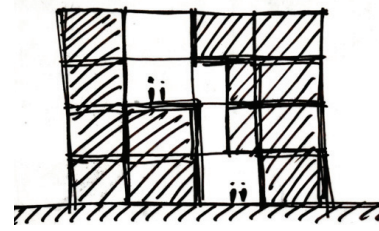

6A

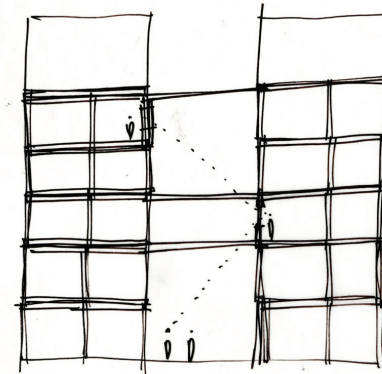

6B

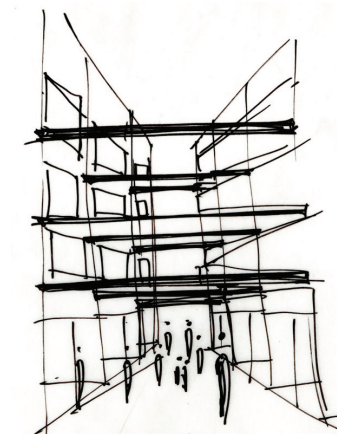

6C

1A-1C: Early massing models illustrate the possibilities for a dense urban complex on the site. 2: Expanding and contracting volumes using a grid. 3: Aligning new structure with the existing structure. 4A-4I: Concept sketches chronicling the process of laying out volumes on the site. 5A: Plaza concept sketch. 5B: Concept sketch of alleys leading to an atrium, the air within a solid volume. 6A-6C: Early concept sketches for the alleys.

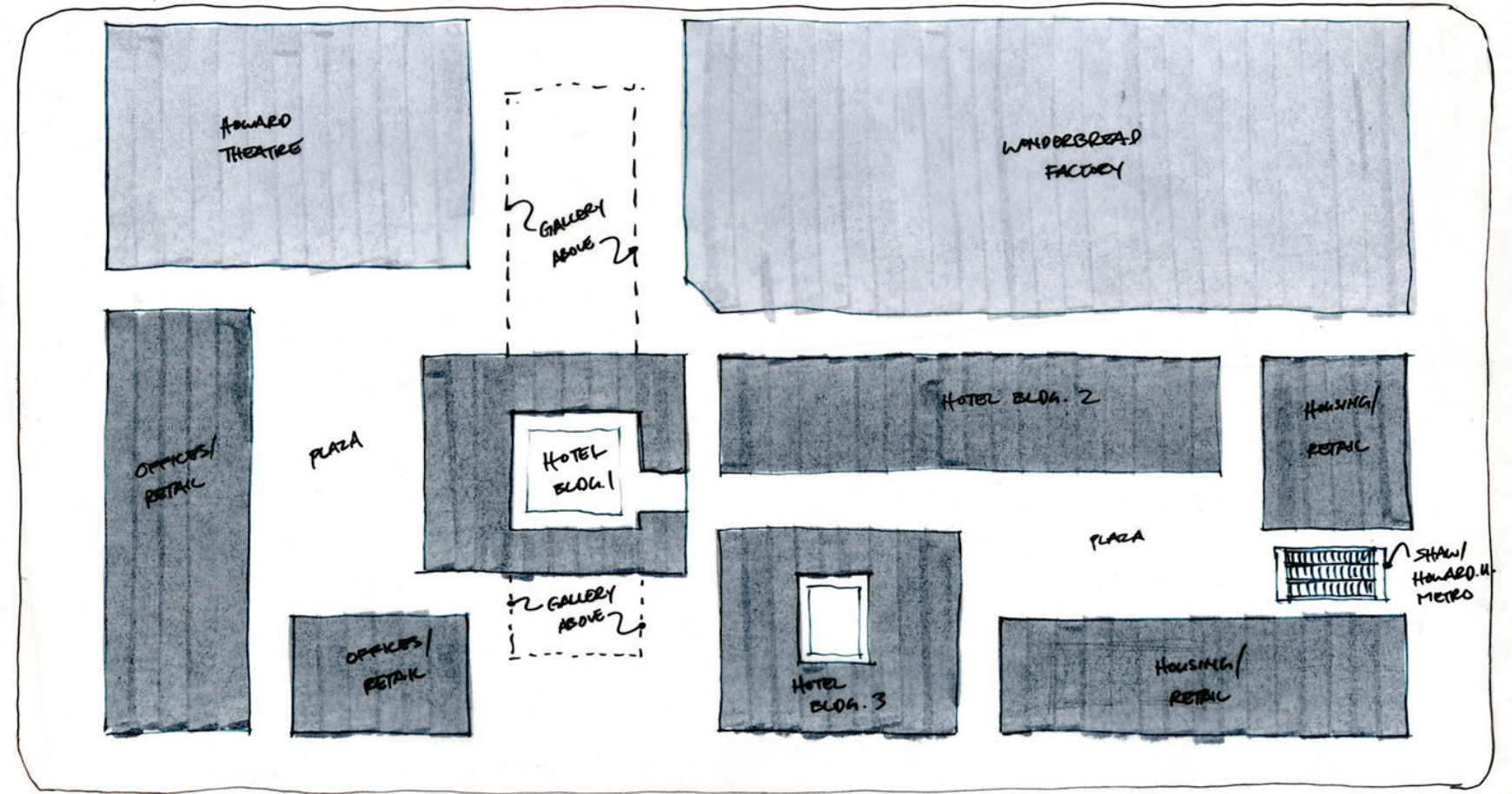
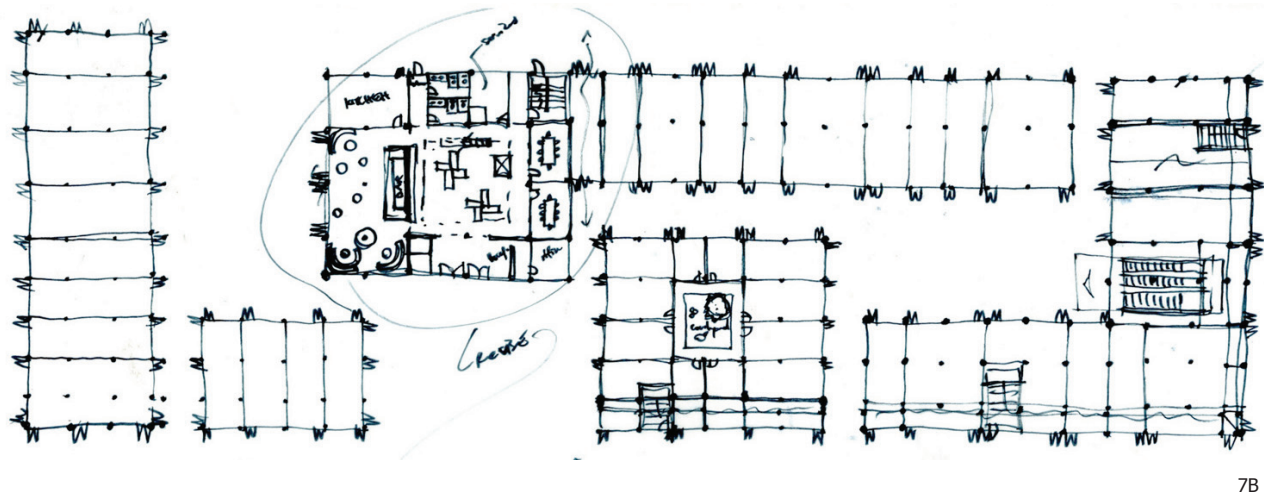
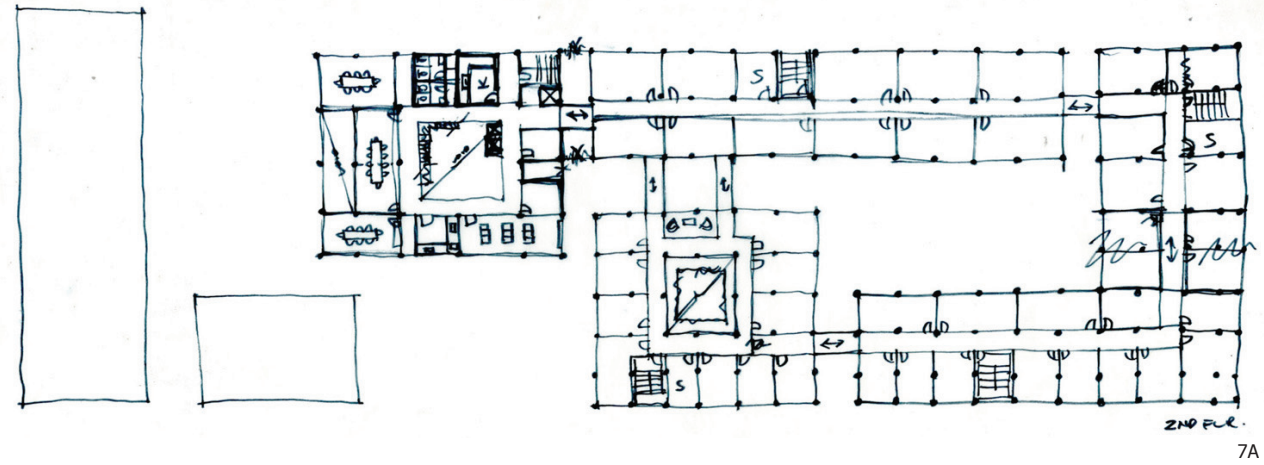

configuring the site

As the overall approach to the project was to allow for future changes to the building program at the end of its lifespan, a system of organizing space on the site was needed which at once laid out the building forms and also allowed flexible reconfigurations.

A rectilinear grid addressed both issues and also fit the forms of the existing buildings on the site. The grid provided a structure by which the buildings on the site could hypothetically expand and/or contract.

The grid was initially divided into equal segments but it was later modified to correspond with the existing structural grids of the Howard Theater and the Wonder Bread Factory. By aligning the structural elements of the old and new buildings, the option of physically connecting both could be made possible.

The new hotel would be part of a complex of buildings situated on the site accommodating various programs. Conceived of as blocks, these buildings were configured to create a mix of open air urban spaces of varying sizes. By varying the paths of circulation around these blocks, traversing the site would inhibit a maze-like experience consisting of narrow alleys and open plazas.

The plazas were treated as large urban courtyards with numerous ways to enter and exit. In order to maintain the feeling of enclosure in the open plazas, the alleys leading to them terminated at the plazas themselves and did not extend past.

The hotel would consist of three buildings that nestled themselves into the group of buildings on the block that included the Howard

Theater, Wonder Bread Factory, and several additional buildings that would house mixed programs such as offices, housing, and/or retail. These additional buildings would not be designed as part of the project; rather they are assigned in the project as buildings that contribute to the formation of the overall complex, but would be designed by others.

The concept of inserting open space into a dense, urban condition continued into two of the hotel buildings in the form of glass-covered atriums.

To create a lively atmosphere and transition space for the Metro escalators, the ground floor was designated as public space in the form of shops, restaurants, and plazas,

The character of the alleys between the buildings were established early on as narrow, activity-filled passageways flanked on both sides by retail spaces on the ground floor level, and hotel rooms on the upper levels.

7A, 7B: Initial ground floor and second floor plans - the ground floor was designated as public space with retail units that opened into the plazas and alleys, while the upper floors contained the hotel rooms. **8:** Initial diagram of site layout - existing and new buildings arranged as blocks on the site.

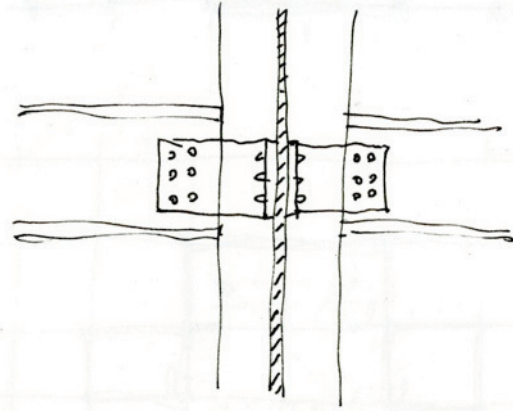

1A

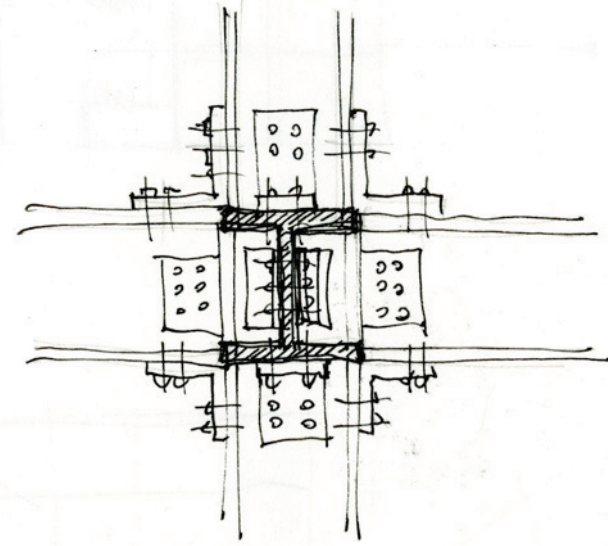

1B

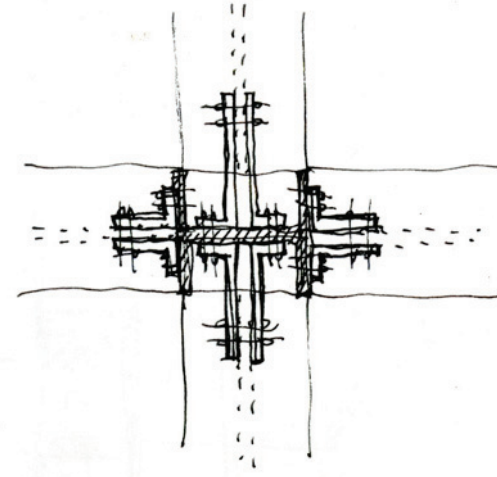

1C

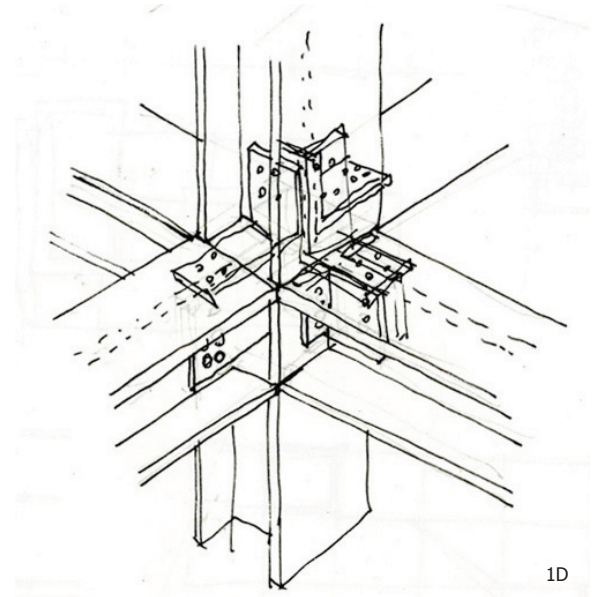

1D

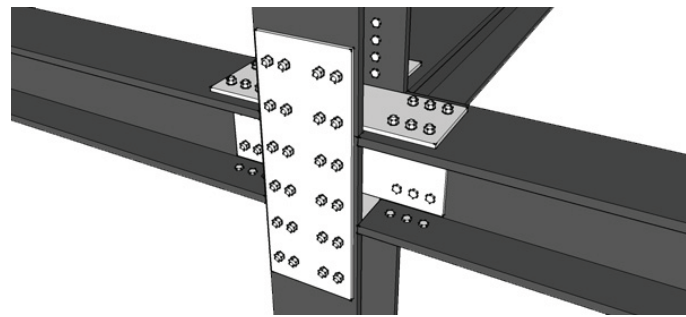

2A

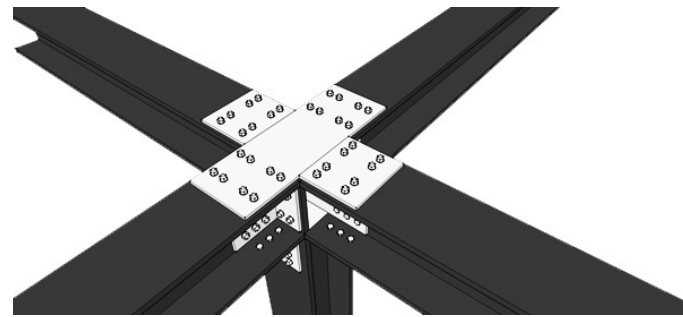

2B

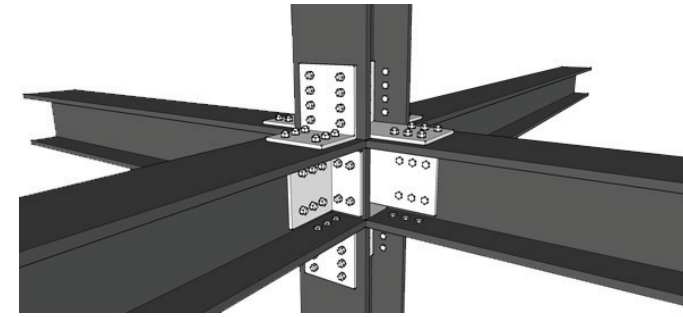

2C

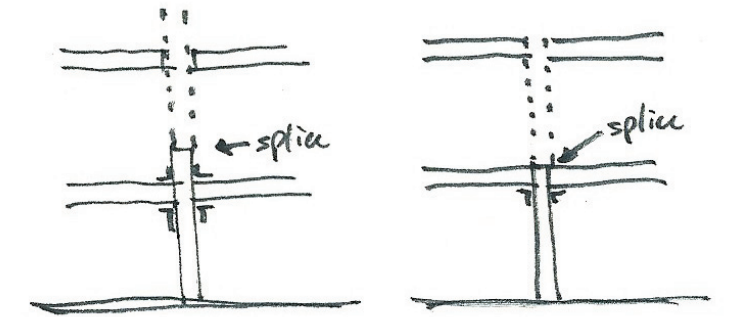

3

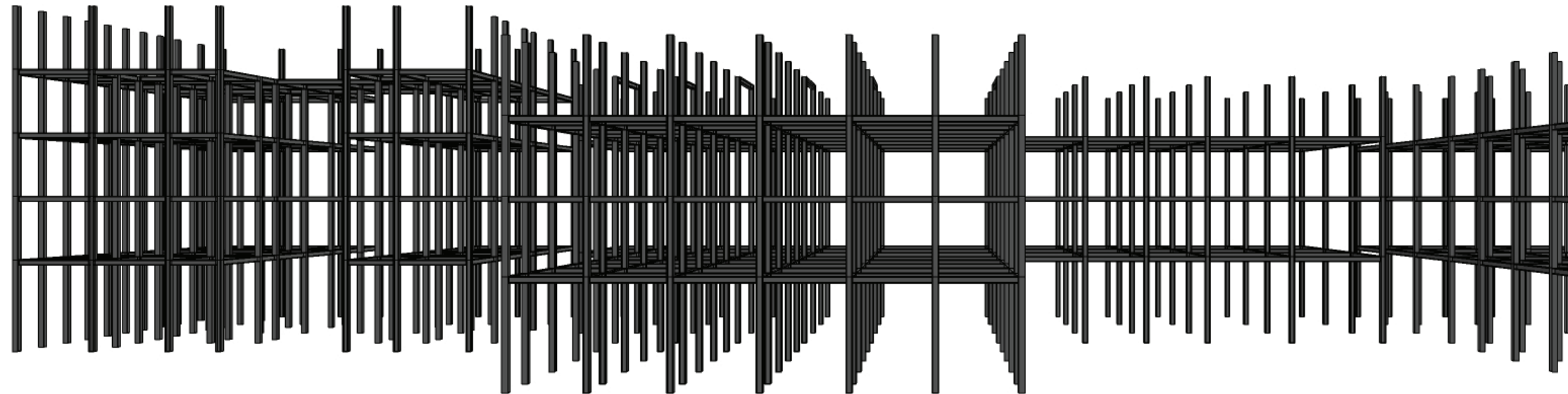

4

structure

A steel frame structure with bolted connections was the construction system chosen for the project for its strength and its ability to be recycled. But more importantly, the use of bolted connections made the structure disassemblable.

Steel plates and angled cleats were used to connect beams to columns. Since beam coping limits the reusability of beams, it is avoided in this project and instead, extended angled cleats are bolted to the beam and column webs.

Typically, steel columns are spliced several feet above beam level in order to provide room for splicing plates to be installed. However, this system limits flexibility because it leaves a portion of column exposed above the floor level. In this design the structure's columns terminate at beam level to provide a clear floor space, making it easy to configure spaces in the future if a column is to be removed. To compensate for structural forces at the column and beam connections, larger angled cleats and bolts are used and installed at every angle.

Using this system, the steel members can be easily taken apart as desired, and they can either be reused to build another part of the building or be melted to create new steel parts.

1A-1D: Sketches of bolted connections. **2A-2C:** Models of bolted connections at varying locations. **3:** Splice diagram - columns end at beam level rather than run above it, providing clear floor space should a column be removed in the future. **4:** The hotel's steel frame matrix.

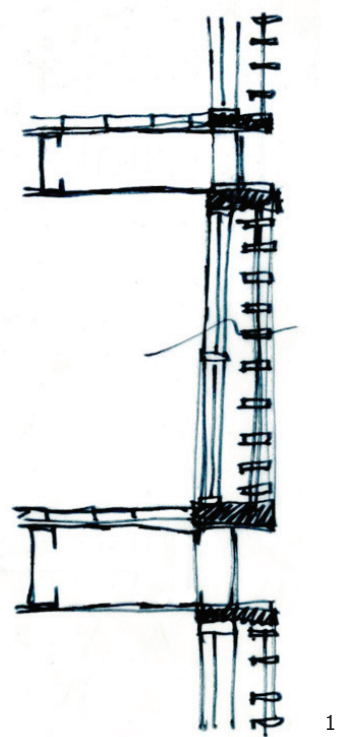

1

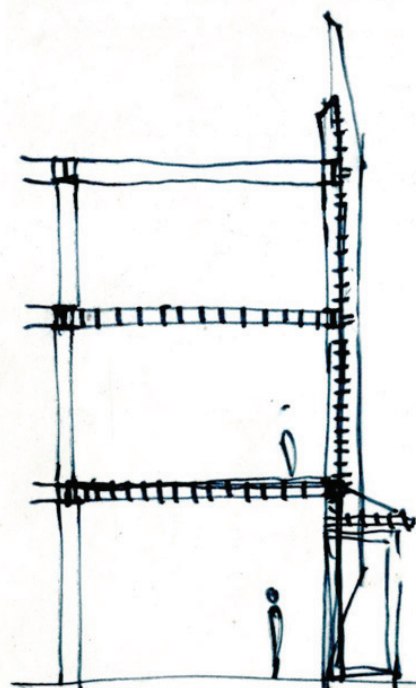

2

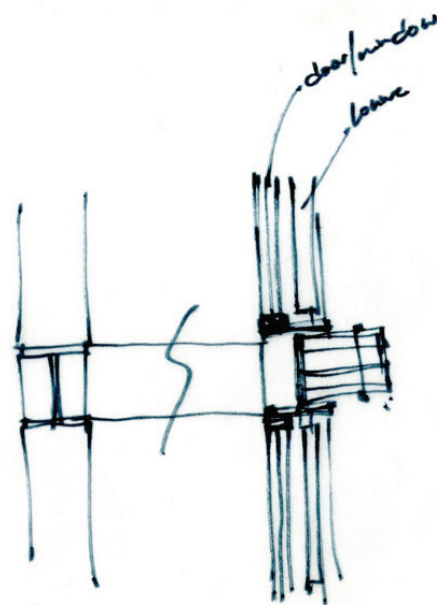

door/window frame

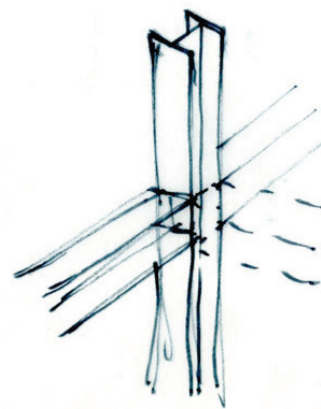
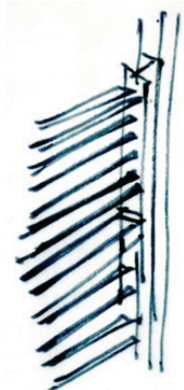

3

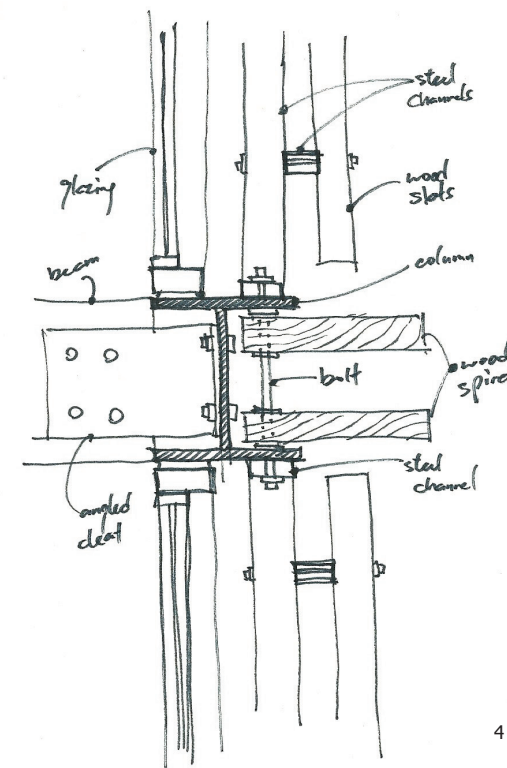

4

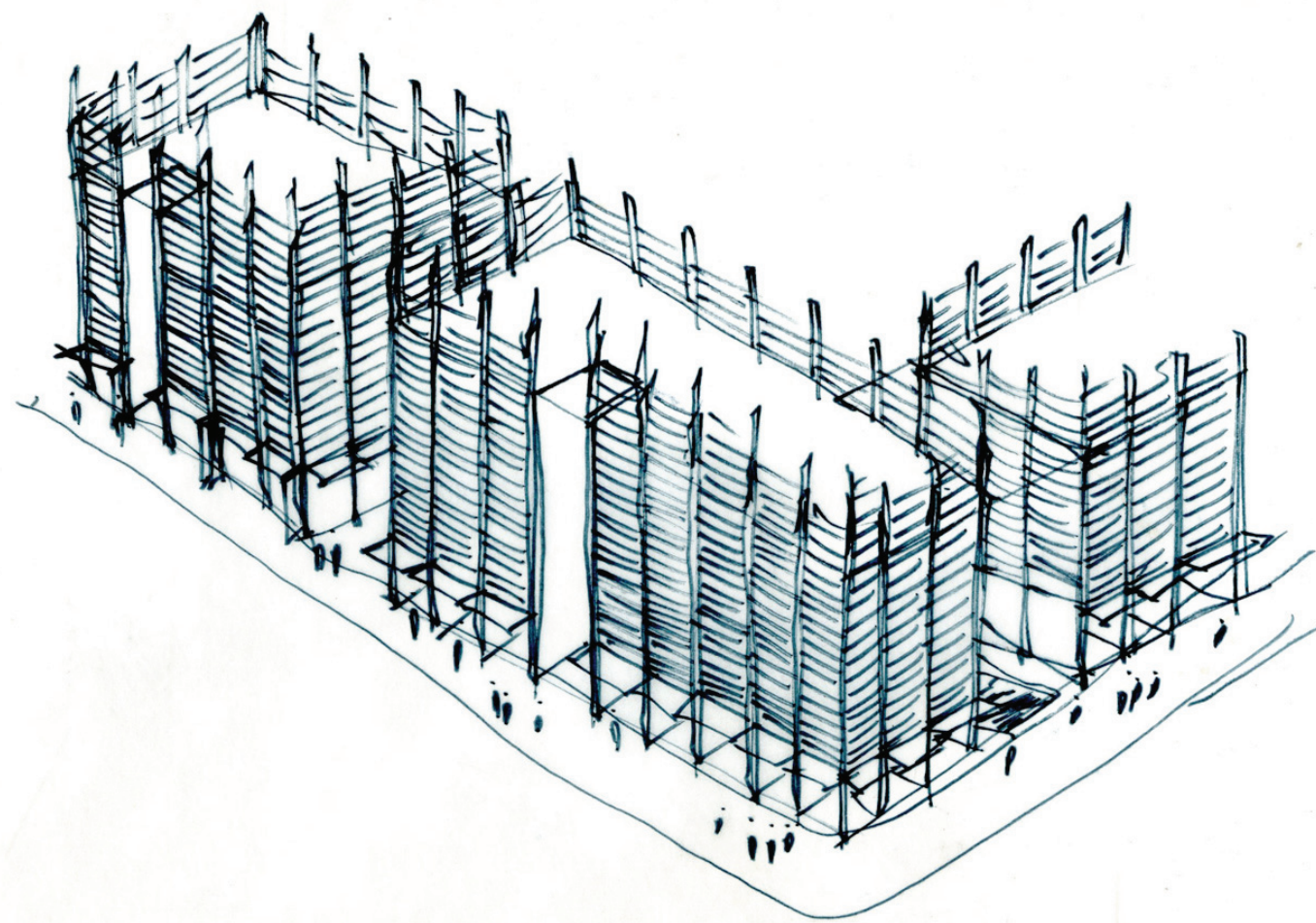

6

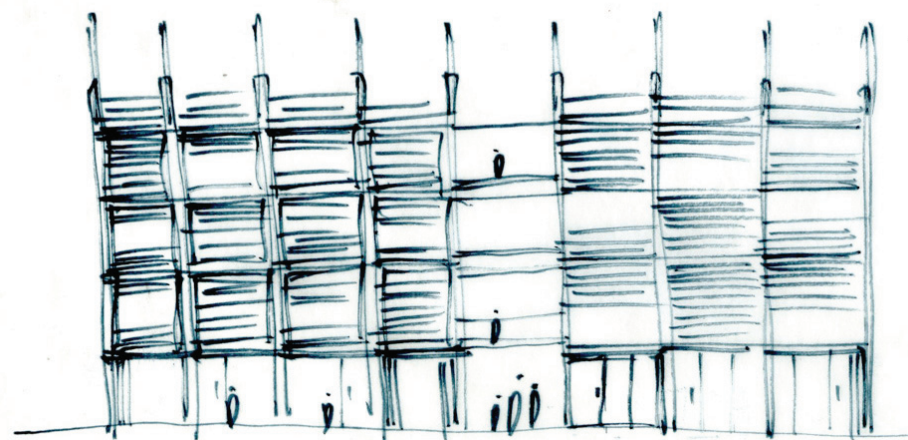

5

facade + expression

The concept of disassembly and designing for future change is expressed with a facade composed of lightweight materials - wood slats over a glazed facade. The narrow horizontal slats fixed between the steel frame create a sense of lightness that expresses the building as a structure that is at once strong and resilient, but at the same time, light and transient.

Another set of steel columns are added on top of the building perimeter columns in anticipation of a future vertical expansion, creating tall elements that rise to the sky. Large wood spires are attached to the steel columns to further emphasize this vertical gesture.

1: Section detail sketch of facade. 2: Section sketch of facade. 3: Detail sketches of facade connections. 4: Detail of facade elements' connection to column - the wood slats are bolted to a steel channel support structure, which is in turn bolted to the steel column. The bolts securing the facade support structure also secure the wood spires, which are inserted into the steel column. 5: Facade elevation study. 6: Facade perspective study.

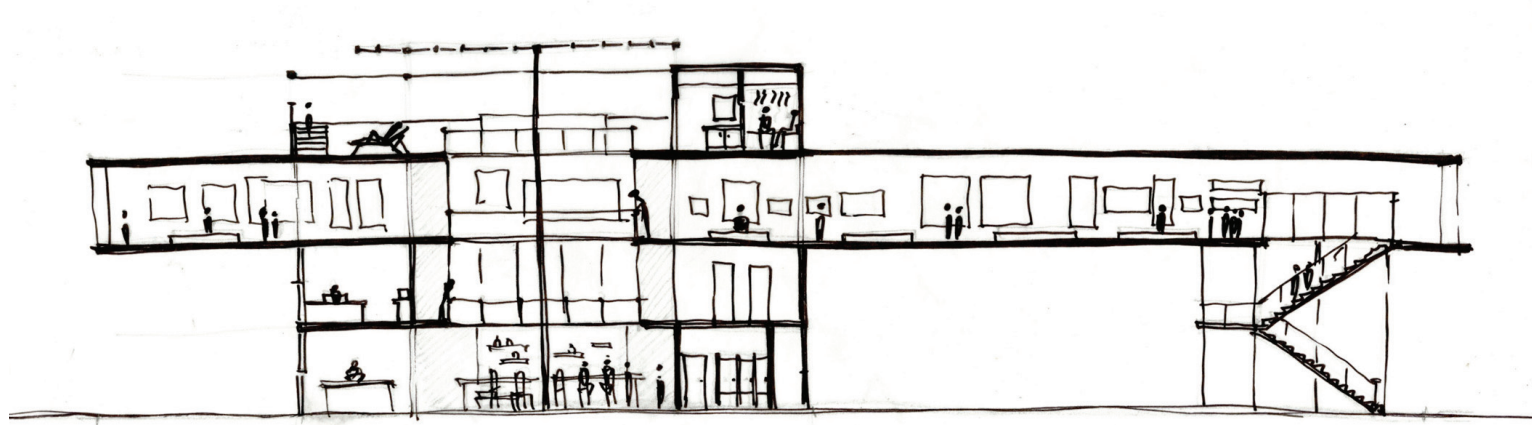

1

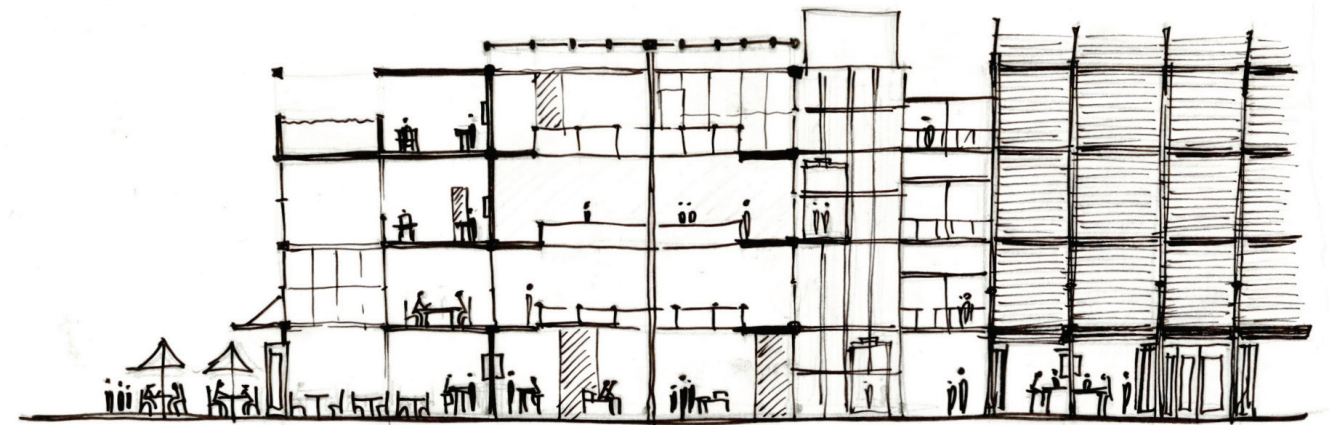

2

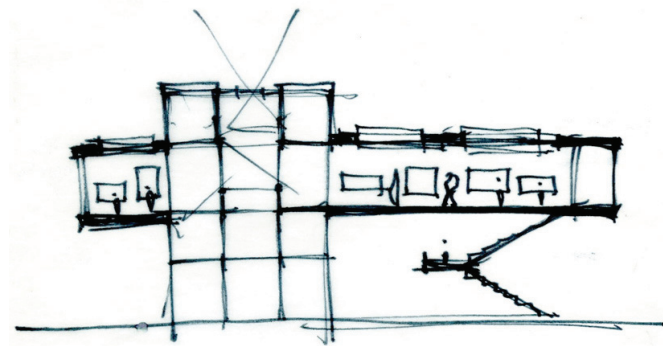

3A

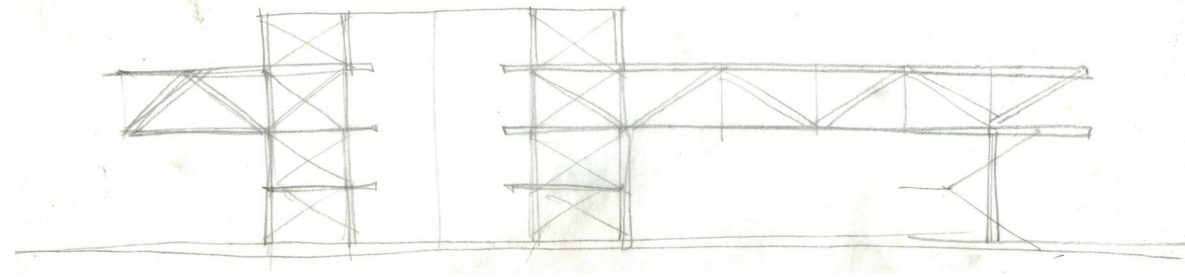

4A

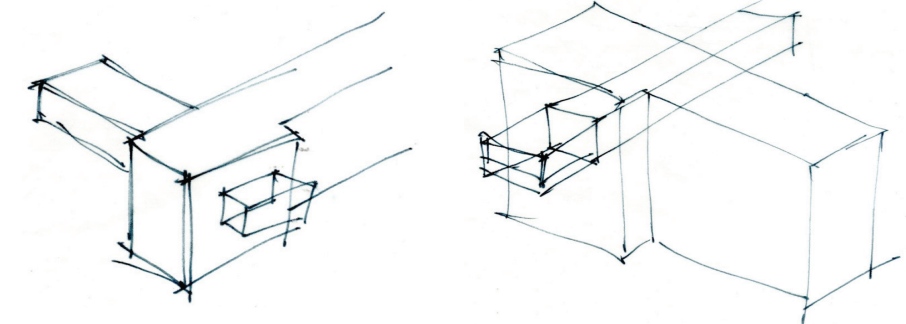

6

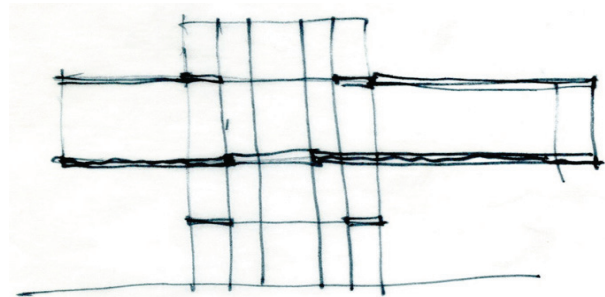

3B

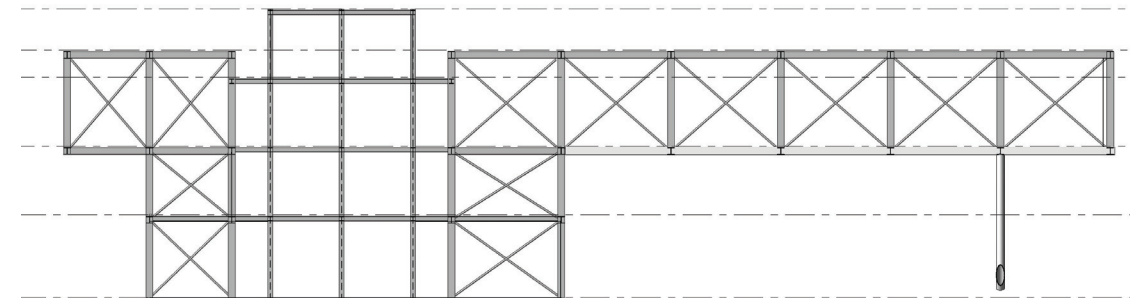

4B

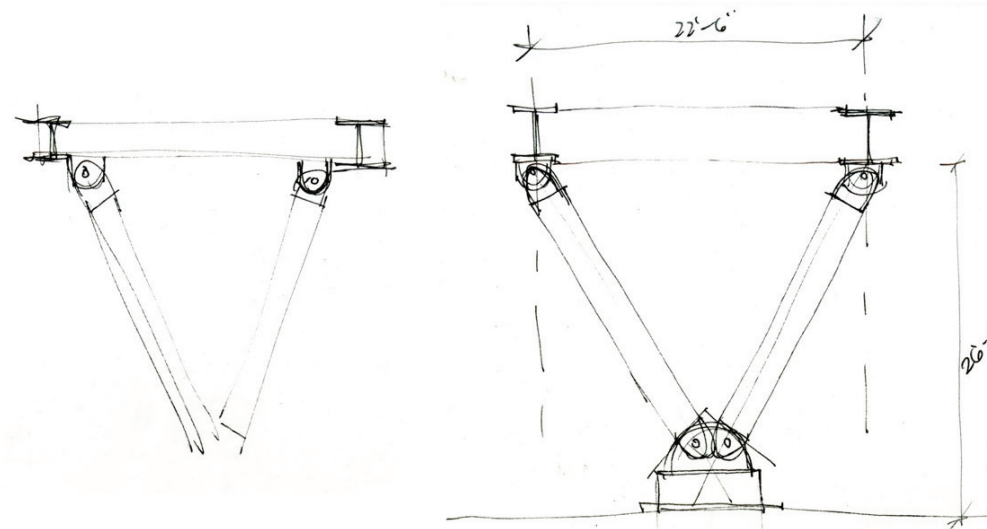

5

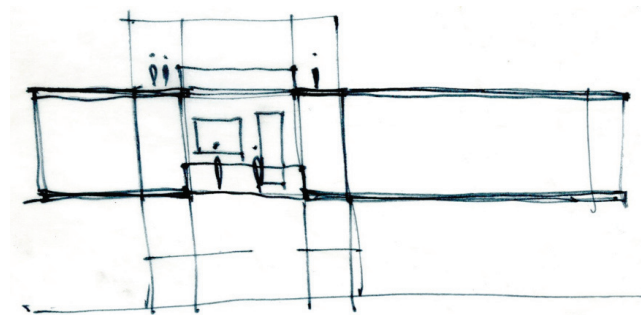

3C

the main hotel building

Situated in the middle of the site, the hotel's main building houses the service-oriented functions of the hotel such as the reception and concierge, a restaurant, conference rooms, a pool and fitness room, and a floating art gallery.

Its striking feature is the long rectangular tube that is thrust through the mass of the building. This tube houses the art gallery and extend to the east and west with views of the city.

It is constructed with steel beams and columns braced laterally to create long trusses. While the tube structure was initially as high as a typical floor, it was later raised to heighten the volume of space within the gallery. The trusses break in the middle of the building to allow space for circulation on the art gallery and roof levels.

The gallery is supported on the east side with diagonal steel struts that converge at a pinned joint on the ground floor level.

1: East-west section sketch. **2:** North-south section sketch. **3A-3C:** Concept section sketch studies of the tube's relationship to the adjacent floors and atrium. **4A, 4B:** Structural bracing studies. **5:** Sketch studies for the diagonal struts supporting the gallery's east end. **6:** Initial volume studies of the gallery tube penetrating the hotel building mass.

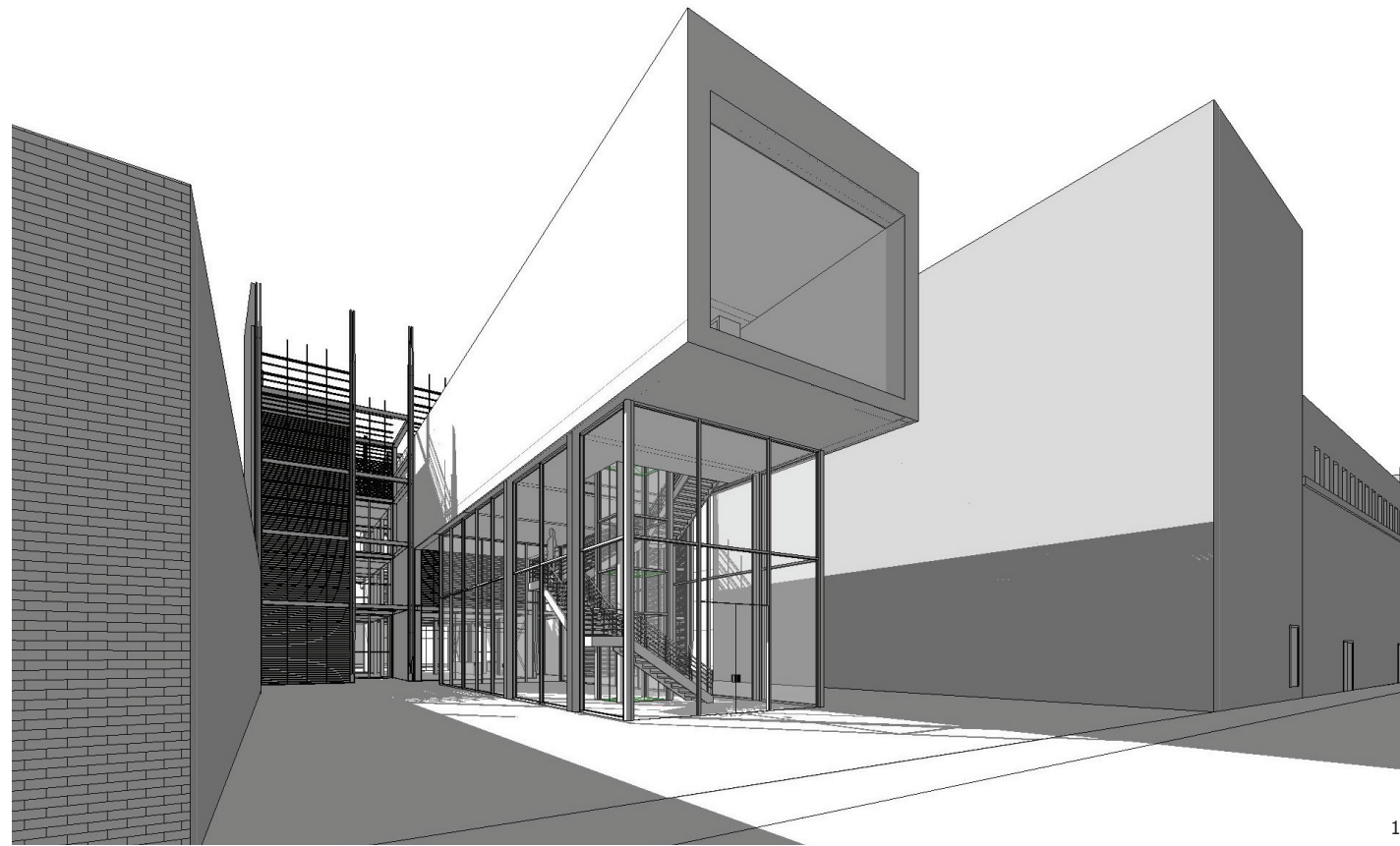

1

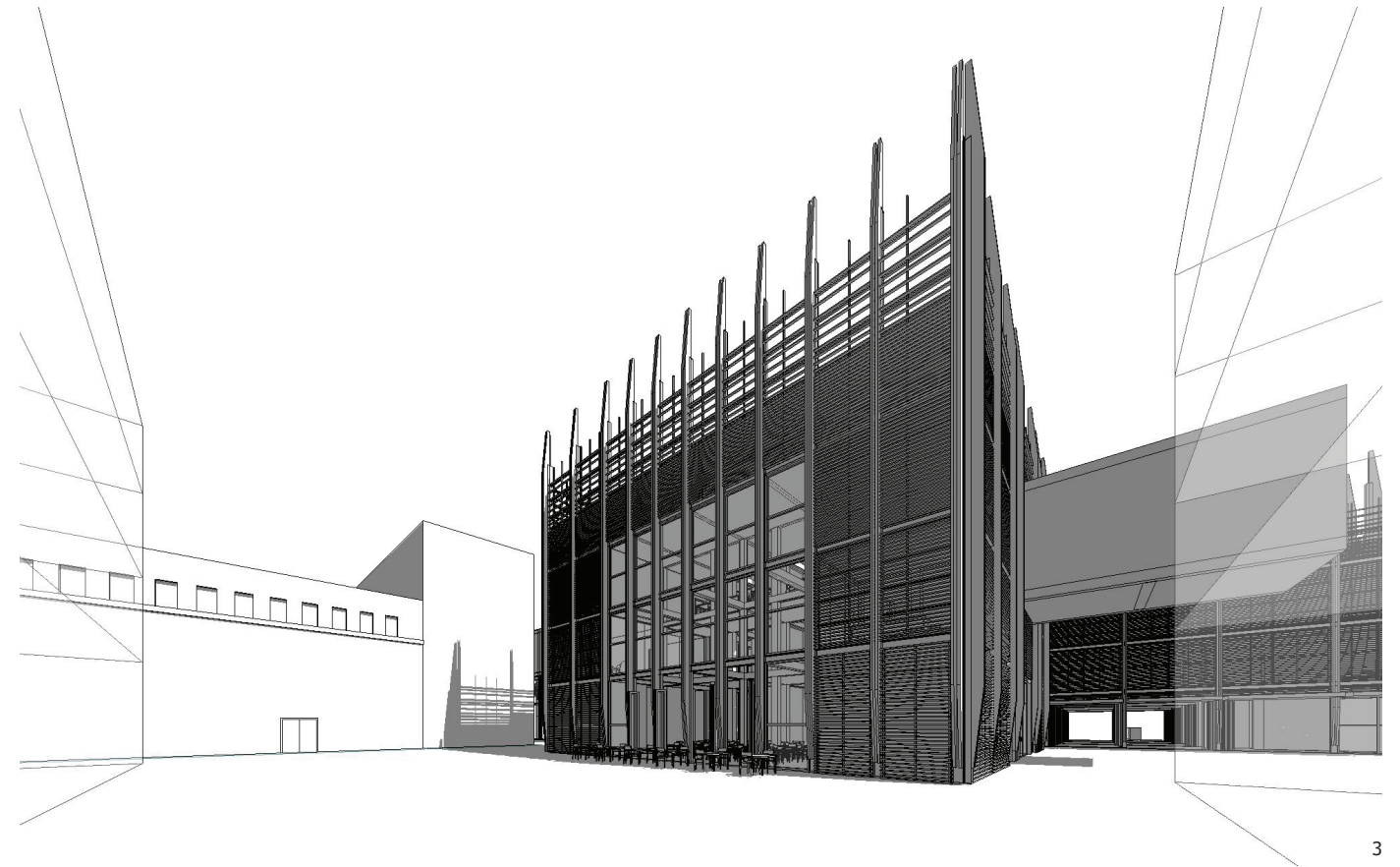

3

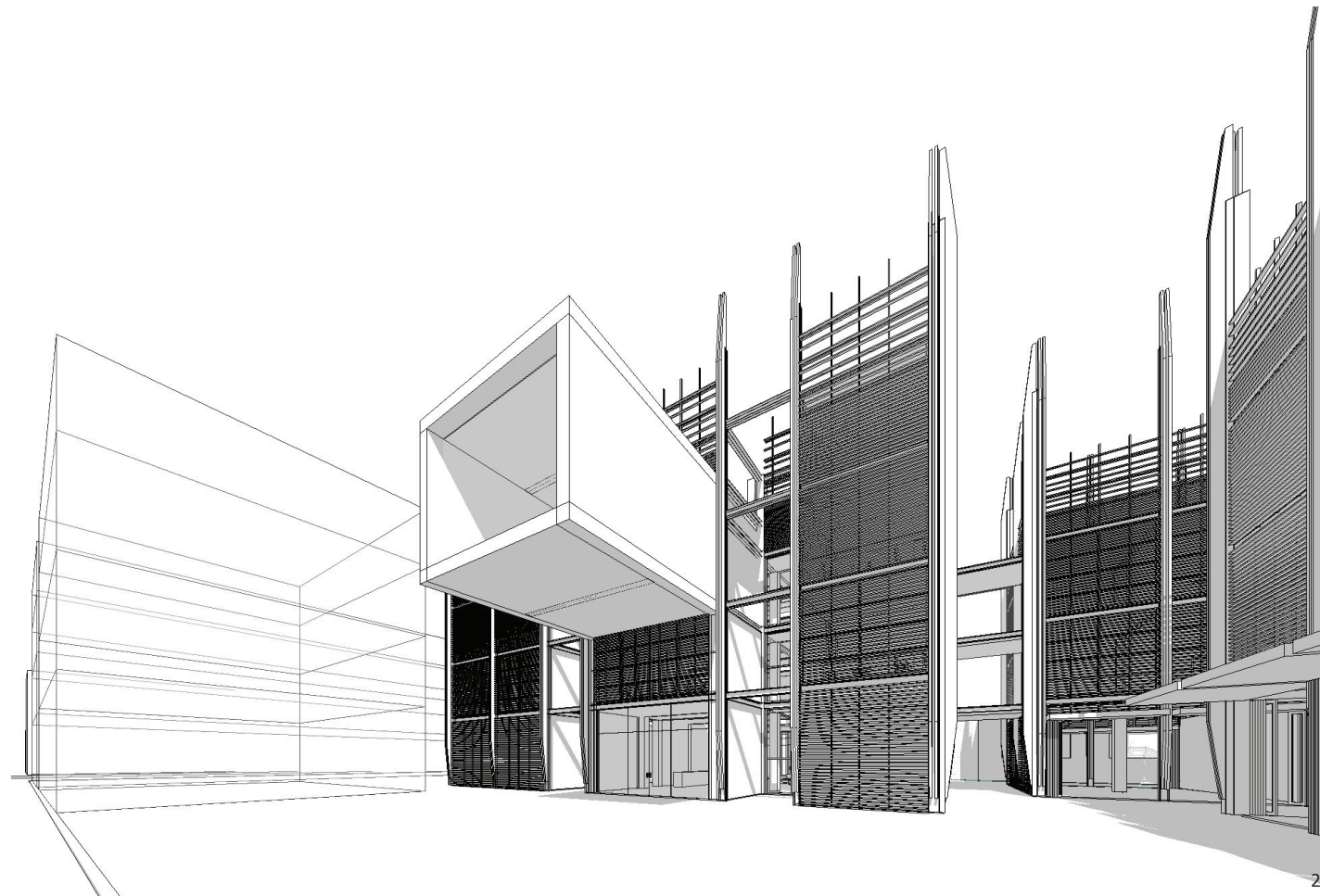

2

1: A preliminary drawing of the main entrance to the gallery - the glazed walls enclose an interior exhibition space as well as stairs that wrap around an elevator leading up to the gallery. The main entry was located adjacent to Wiltburger St., currently used as a service alley, to attract pedestrian traffic to the eastern part of the site. **2:** From 7th St., visitors to the hotel are greeted by the gallery's tube form that hovers over the hotel entrance. **3:** The hotel building's northern facade contains the entry to the hotel's restaurant, where seats spill into the open plaza to engage the space and the programs of the surrounding buildings. This facade prominently showcases the wood spires attached to the steel columns, lending a bit of character to this plaza that is defined also by the Howard Theater and the other two adjacent buildings (left and right side of image).

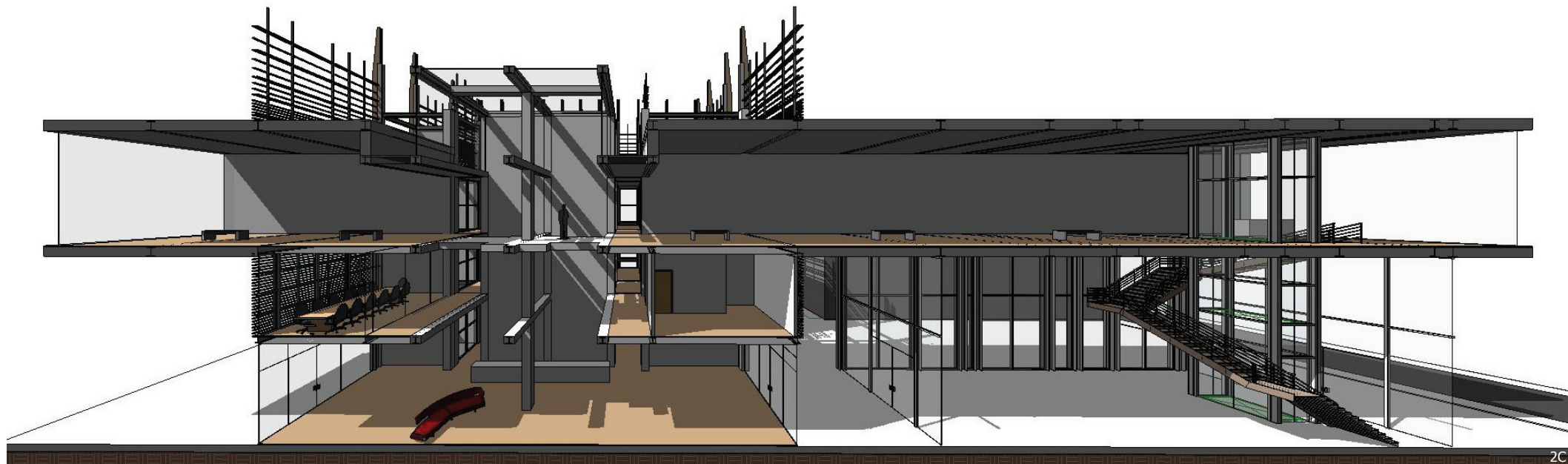
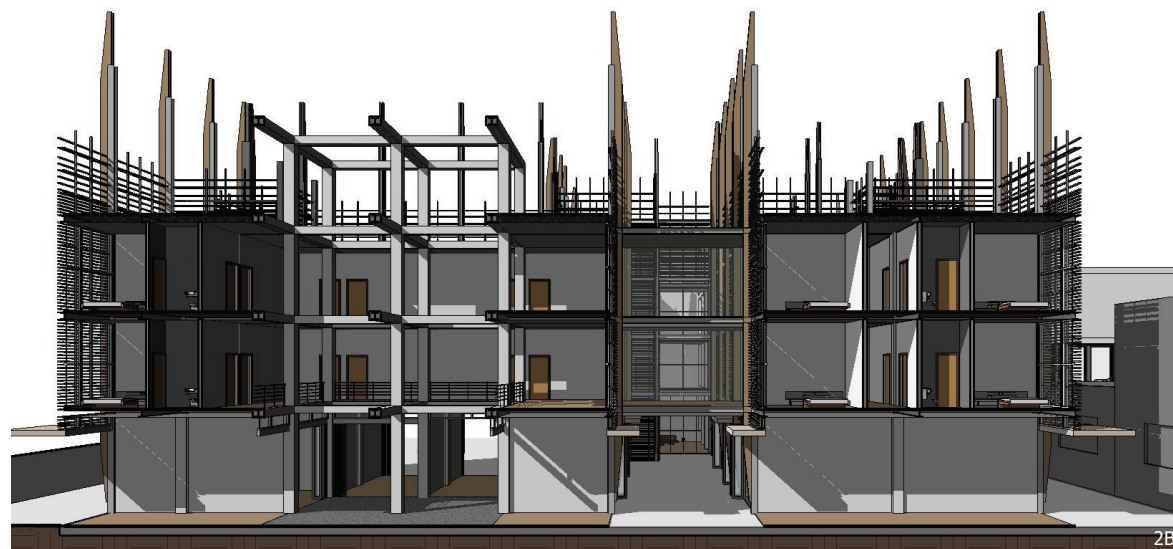
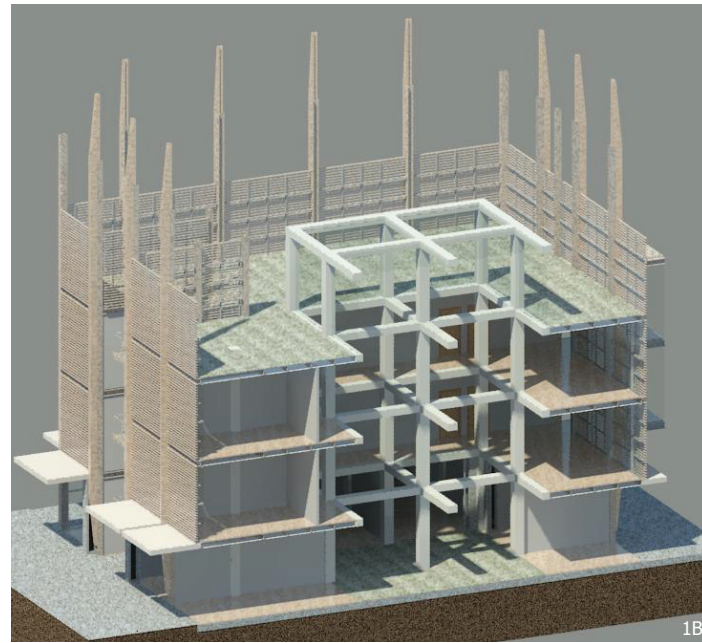
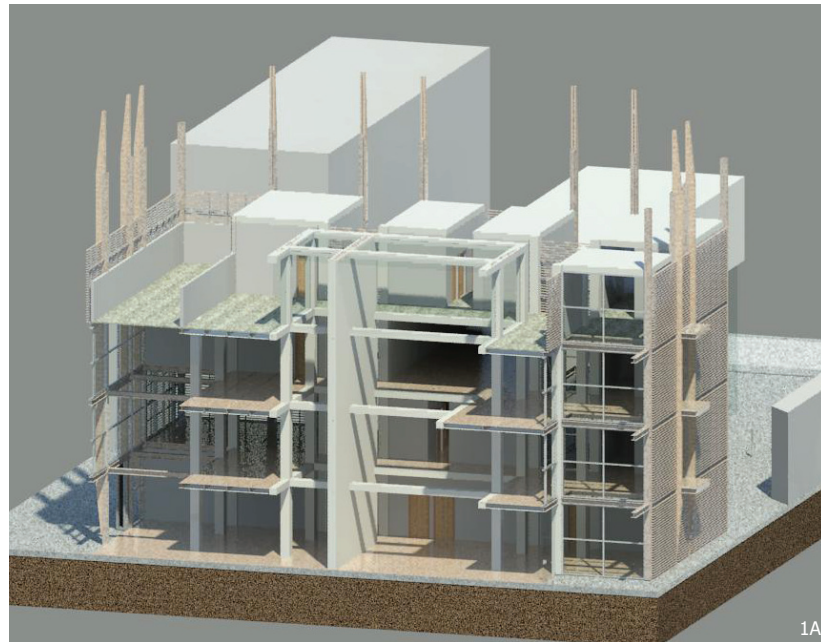

1A: North-south section study of main hotel building - a wall originally intended to divide the hotel lobby and reception area from the restaurant is extended to the top floor to diffuse the sunlight pouring into the building through the atrium. **1B:** East-west section study of hotel room buildings - the hotel rooms open into a large atrium where the building's steel frame is retained as an expression of the design's intent to anticipate future expansion **1C:** East-west section study of main hotel building through gallery - this preliminary render shows a smaller gallery tube prior to raising its height. **2A:** North-south section study of main hotel building - columns are shown encased in drywall, which will later be removed to leave the steel structure and bolted connections exposed. **2B:** East-west section study of hotel room building - the two hotel room buildings are connected by a steel and glass bridge overlooking the narrow alley below, which in turn connects the main hotel building and the metro plaza. The ground floor, housing the retail spaces, is kept open to create a visual and physical connection between streets, retail spaces, and alleys, creating a permeable feeling within the dense complex. **2C:** East-west section study of main hotel building through gallery - structure within the atrium void supports the walkway that connects the gallery's east and west wing, and also exists to support a future expansion.

phase 1:
Final Drawings

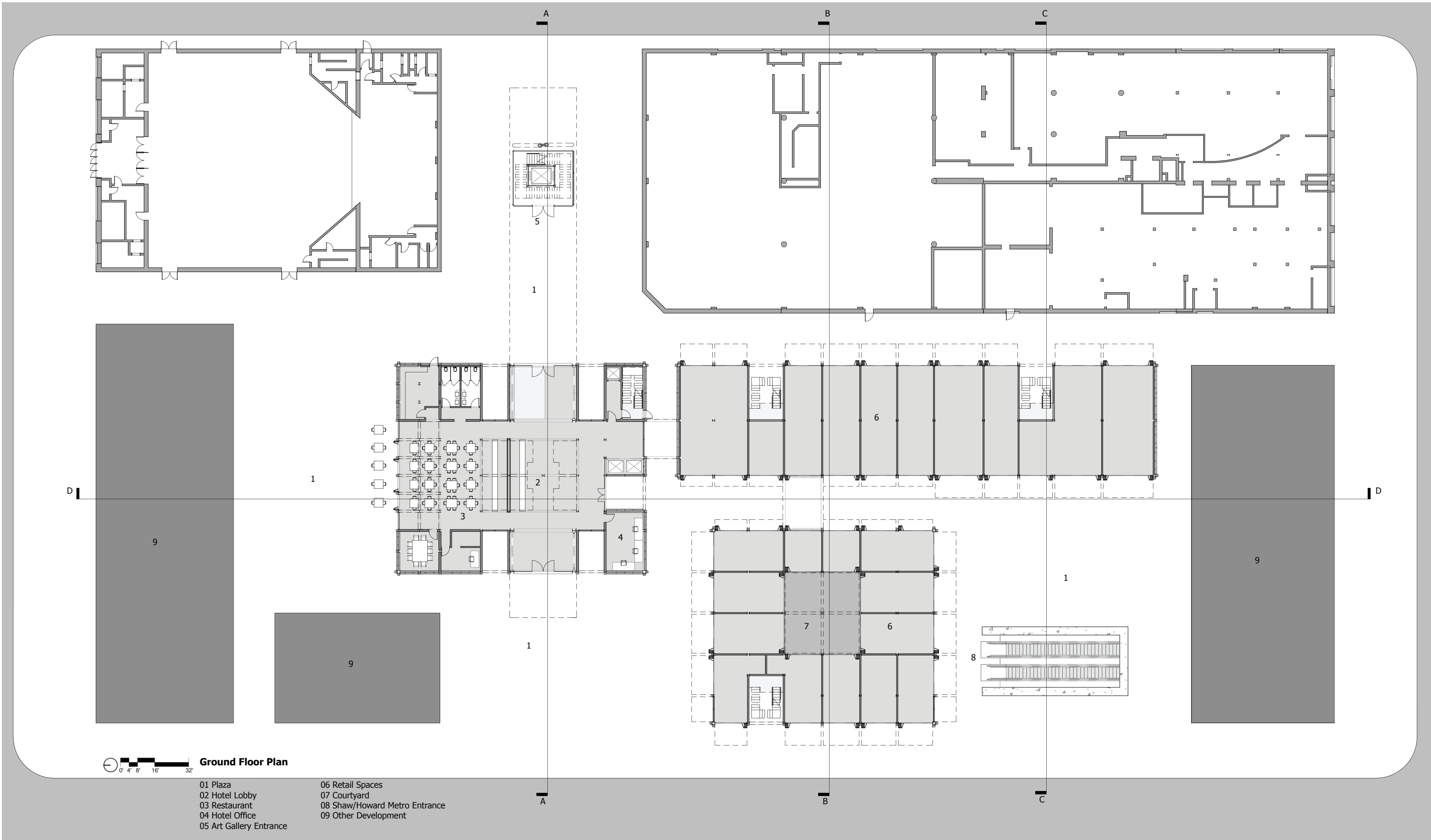

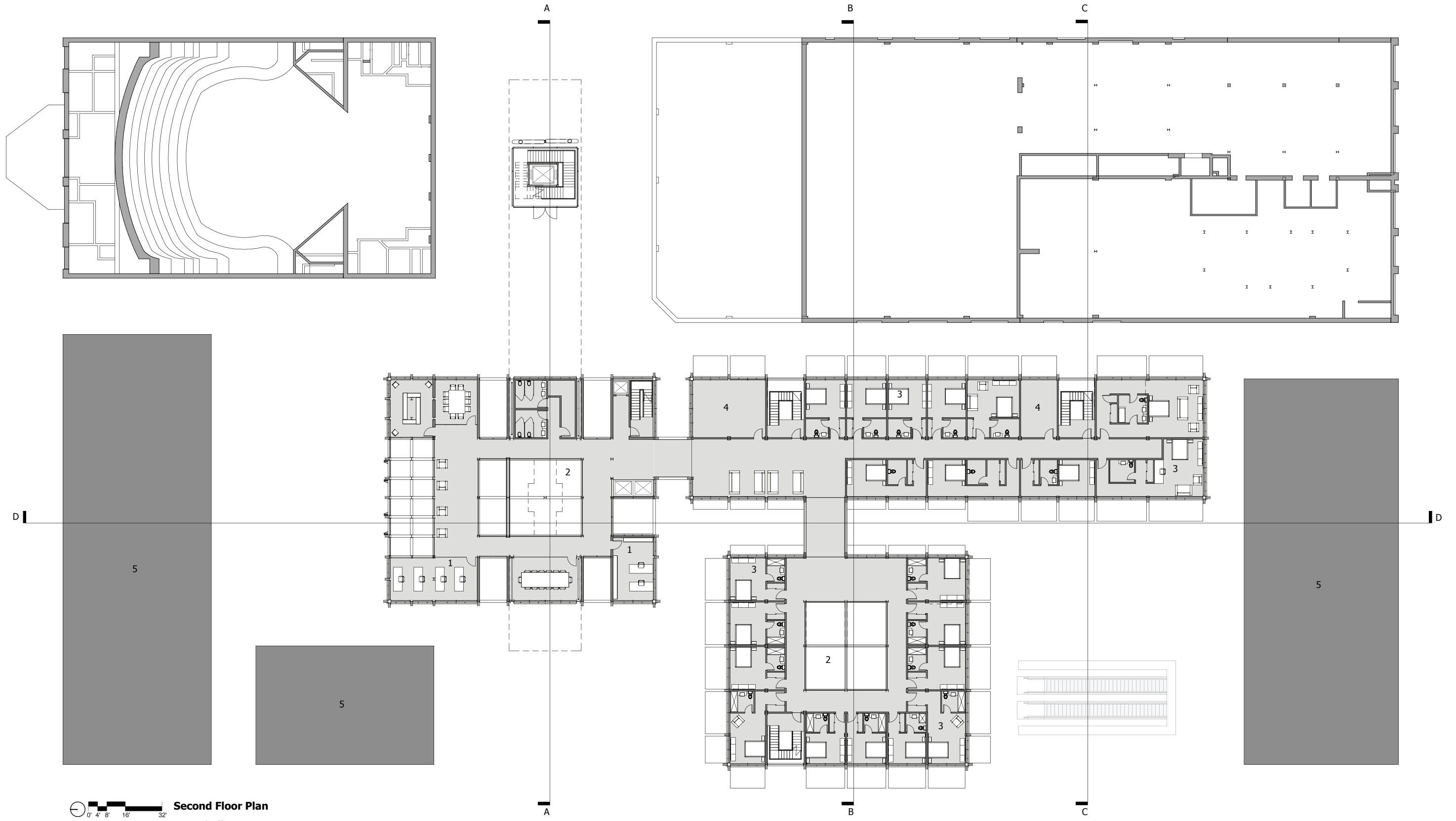

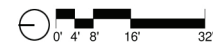
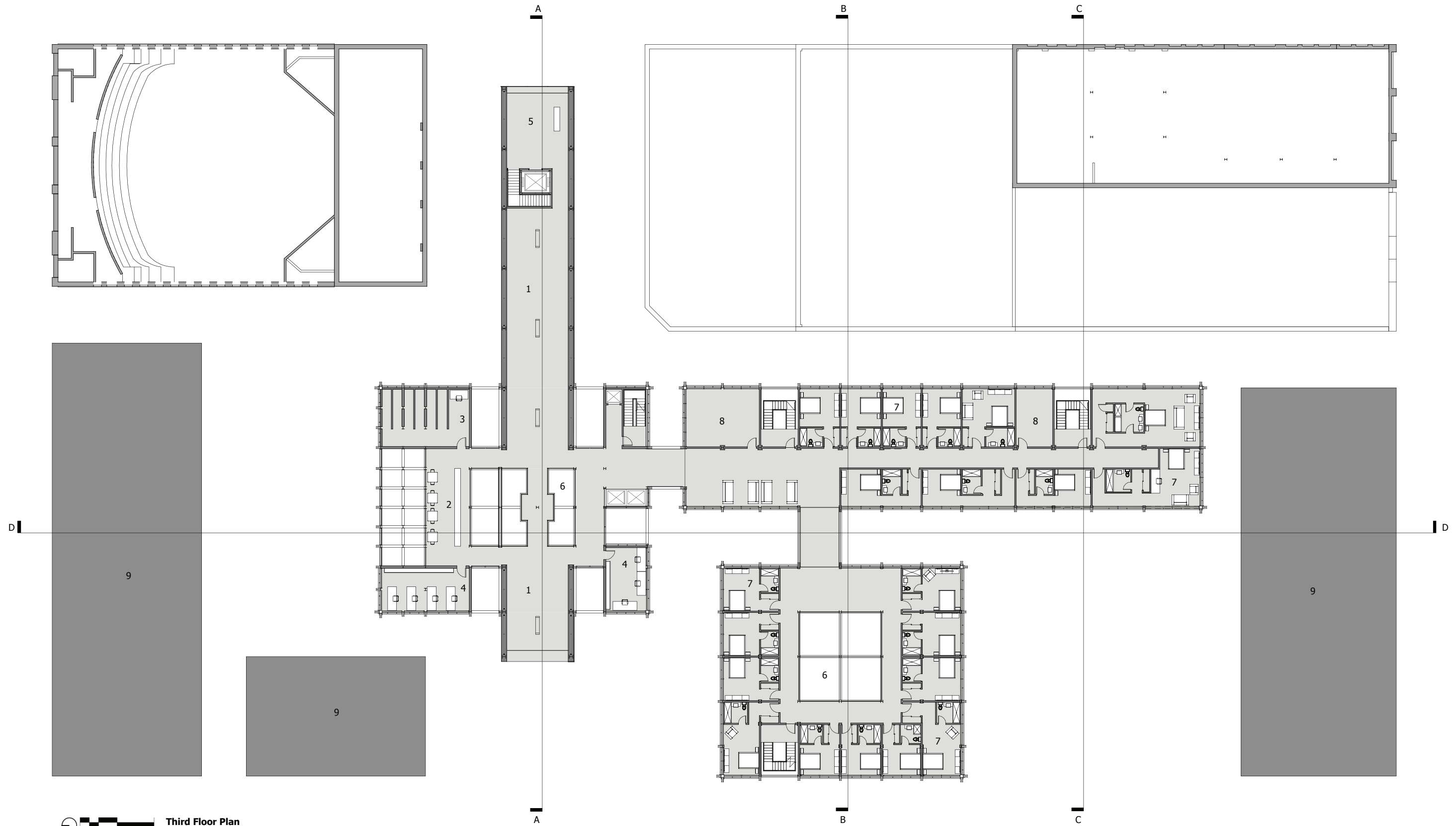

Second Floor Plan
 01 Hotel Office
 02 Atrium
 03 Hotel Rooms
 04 Service
 05 Other Development



Third Floor Plan

- 01 Art Gallery
- 02 Gallery Cafe
- 03 Gallery Storage
- 04 Gallery Offices
- 05 Gallery Reception

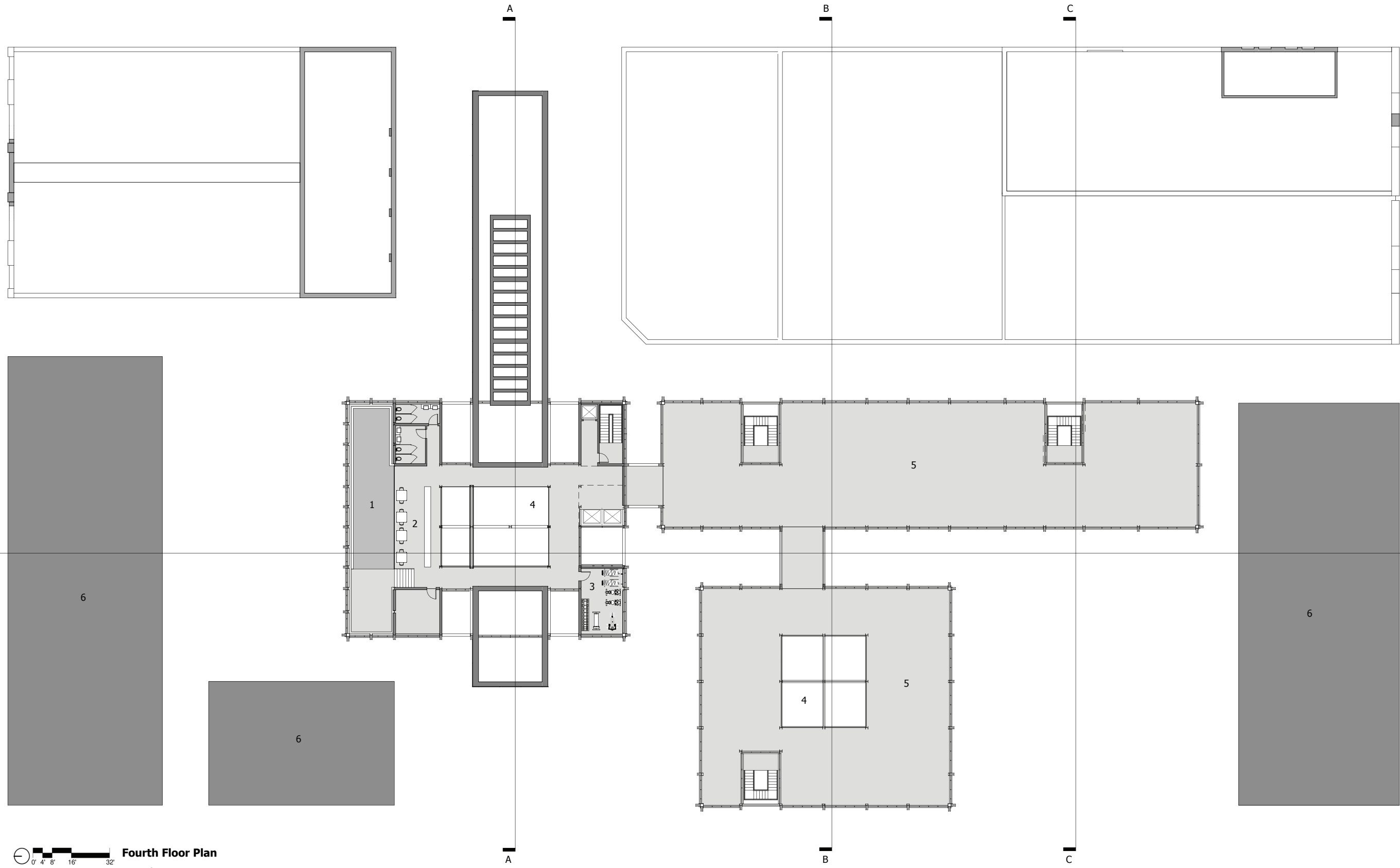
- 06 Atrium
- 07 Hotel Rooms
- 08 Service
- 09 Other Development



Fourth Floor Plan

- 01 Pool
- 02 Pool Bar
- 03 Fitness Room
- 04 Atrium
- 05 Rooftop Terrace
- 06 Other Development

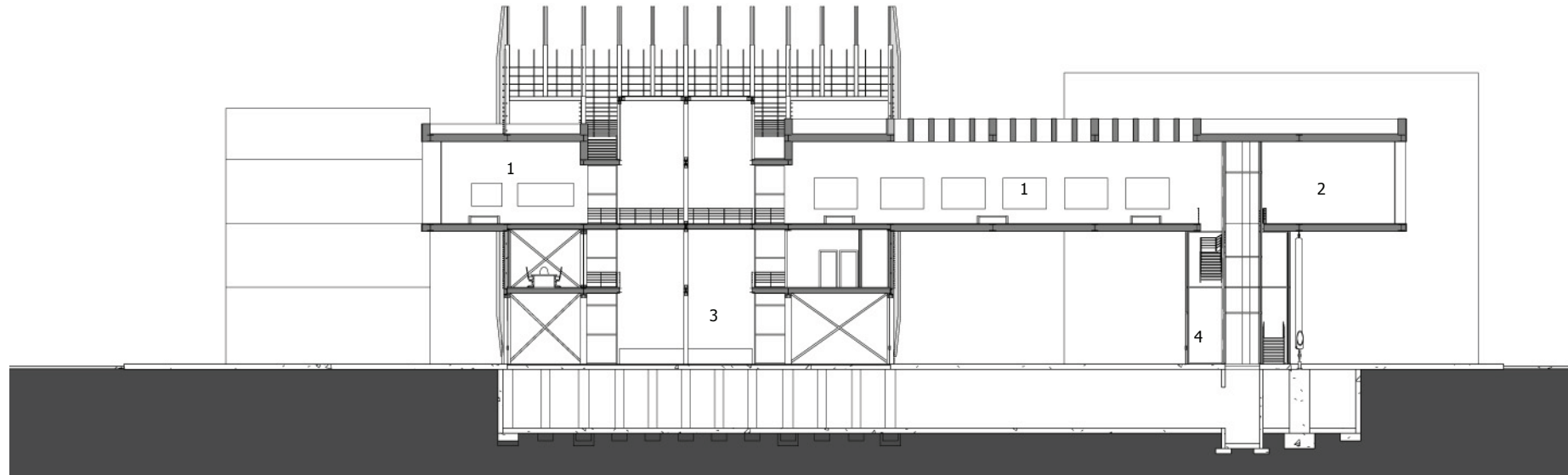

Section A-A

- 01 Art Gallery
- 02 Gallery Reception
- 03 Hotel Lobby
- 04 Gallery Entrance

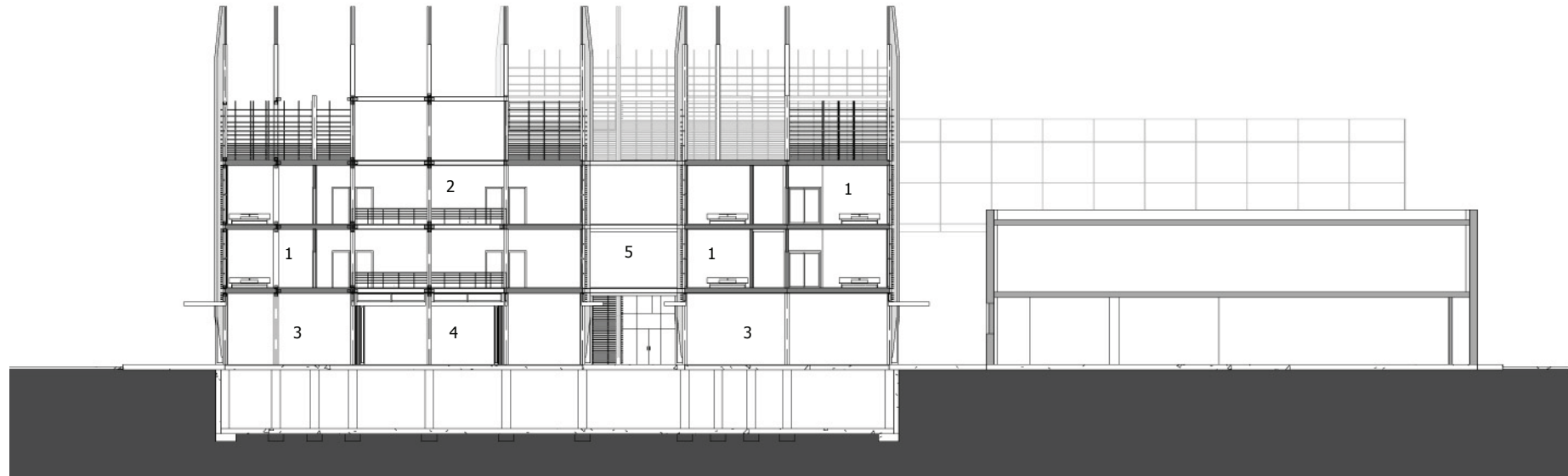

Section B-B

- 01 Hotel Room
- 02 Atrium
- 03 Retail Space
- 04 Courtyard
- 05 Bridge

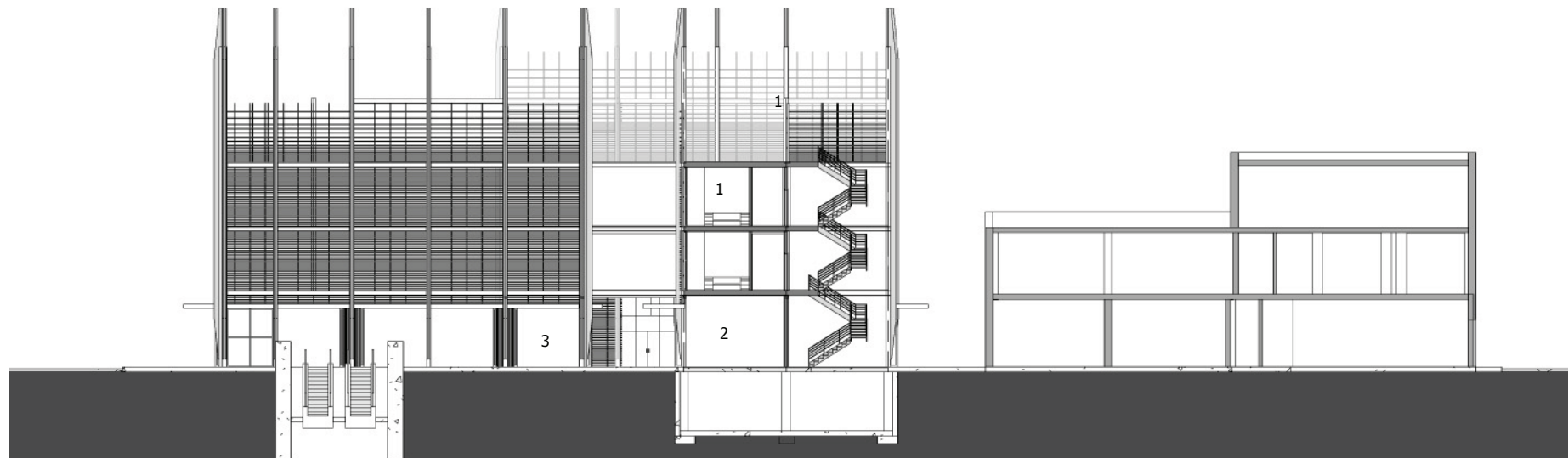

Section C-C

- 01 Hotel Room
- 02 Retail Space
- 03 Plaza



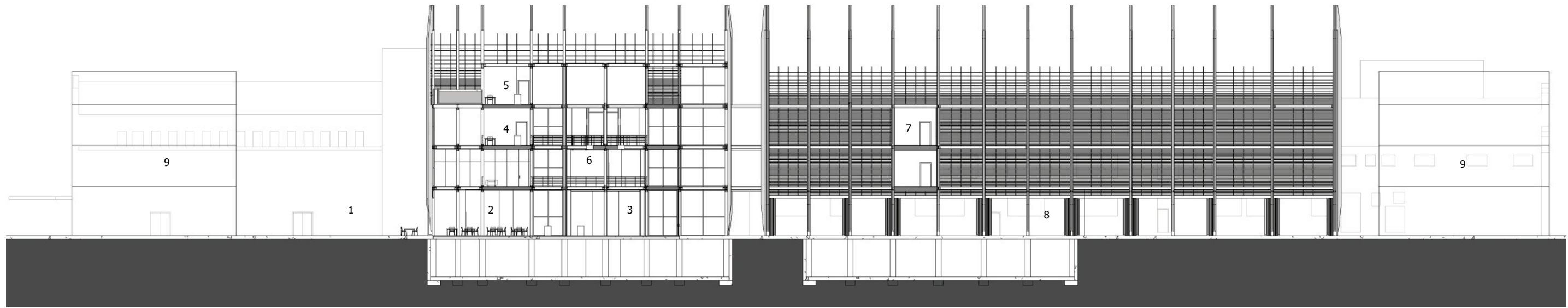

Section D-D

- 01 Plaza
- 02 Restaurant
- 03 Hotel Lobby
- 04 Gallery Cafe
- 05 Pool Bar
- 06 Atrium
- 07 Bridge
- 08 Retail Space
- 09 Other Development

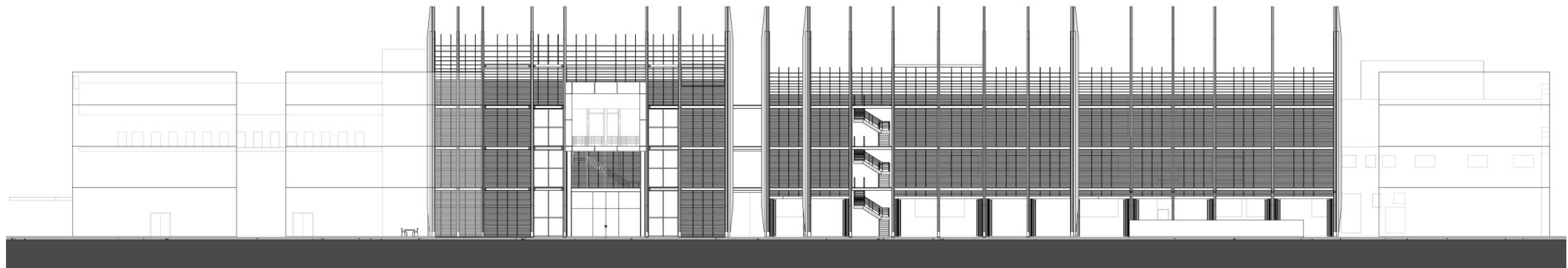

West Elevation

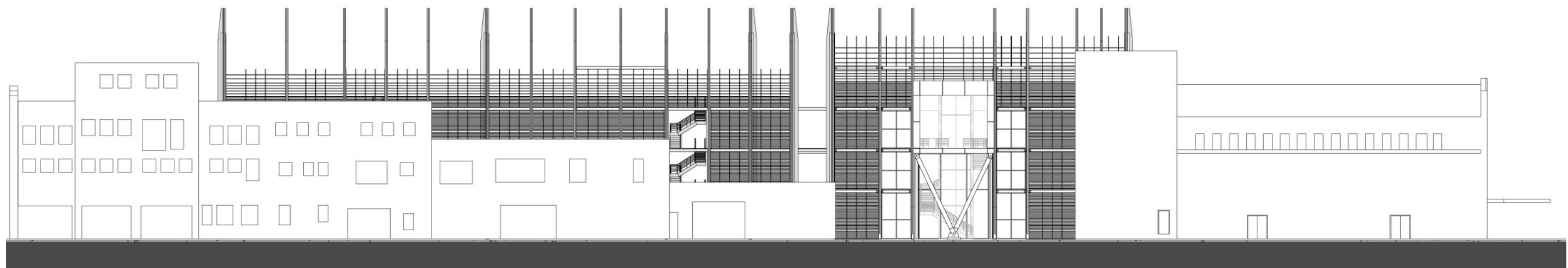

East Elevation

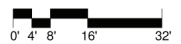

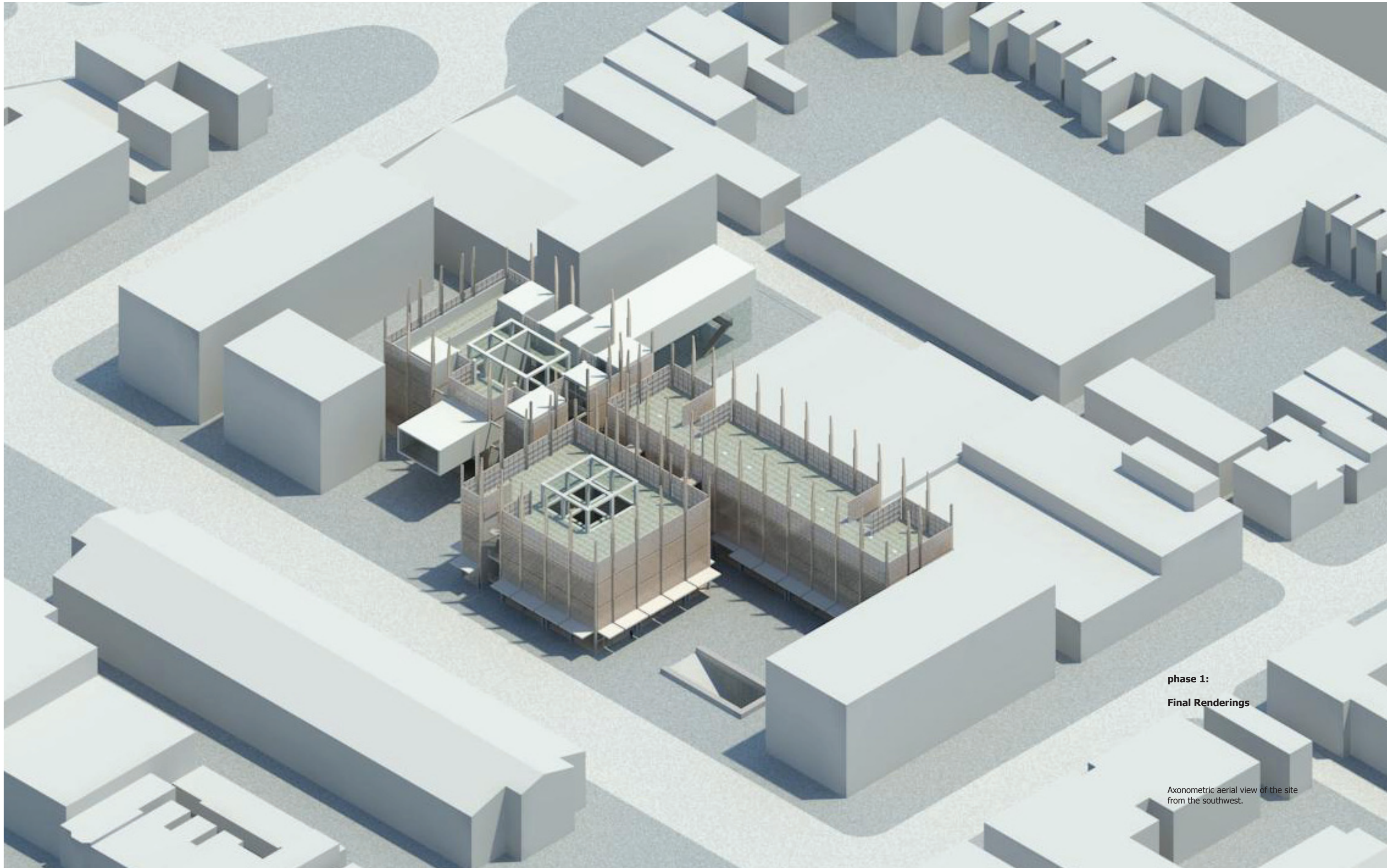

phase 1:
Final Renderings

Axonometric aerial view of the site
from the southwest.



Left: The gallery's tube form extending toward the west marks the main entrance to the hotel. **Right:** A narrow alley leading to the main hotel building creates a dense, crowded space bustling with activity.

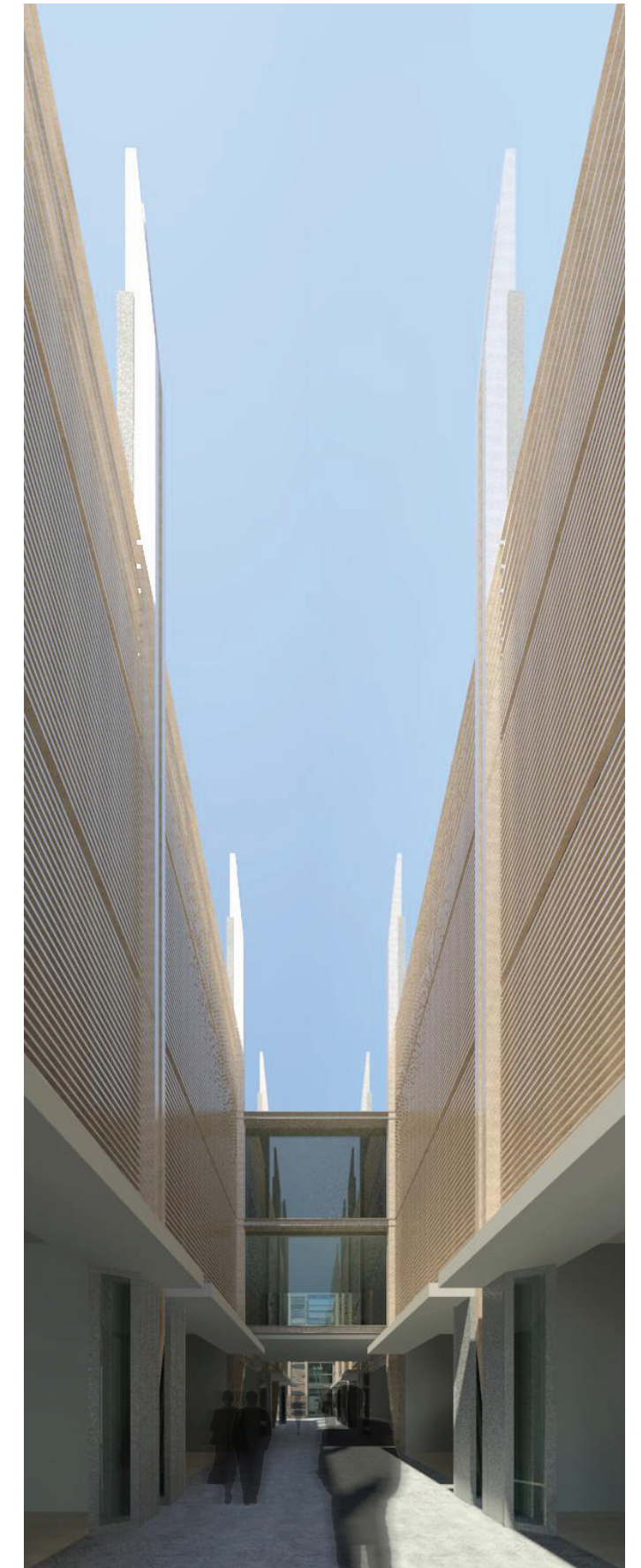

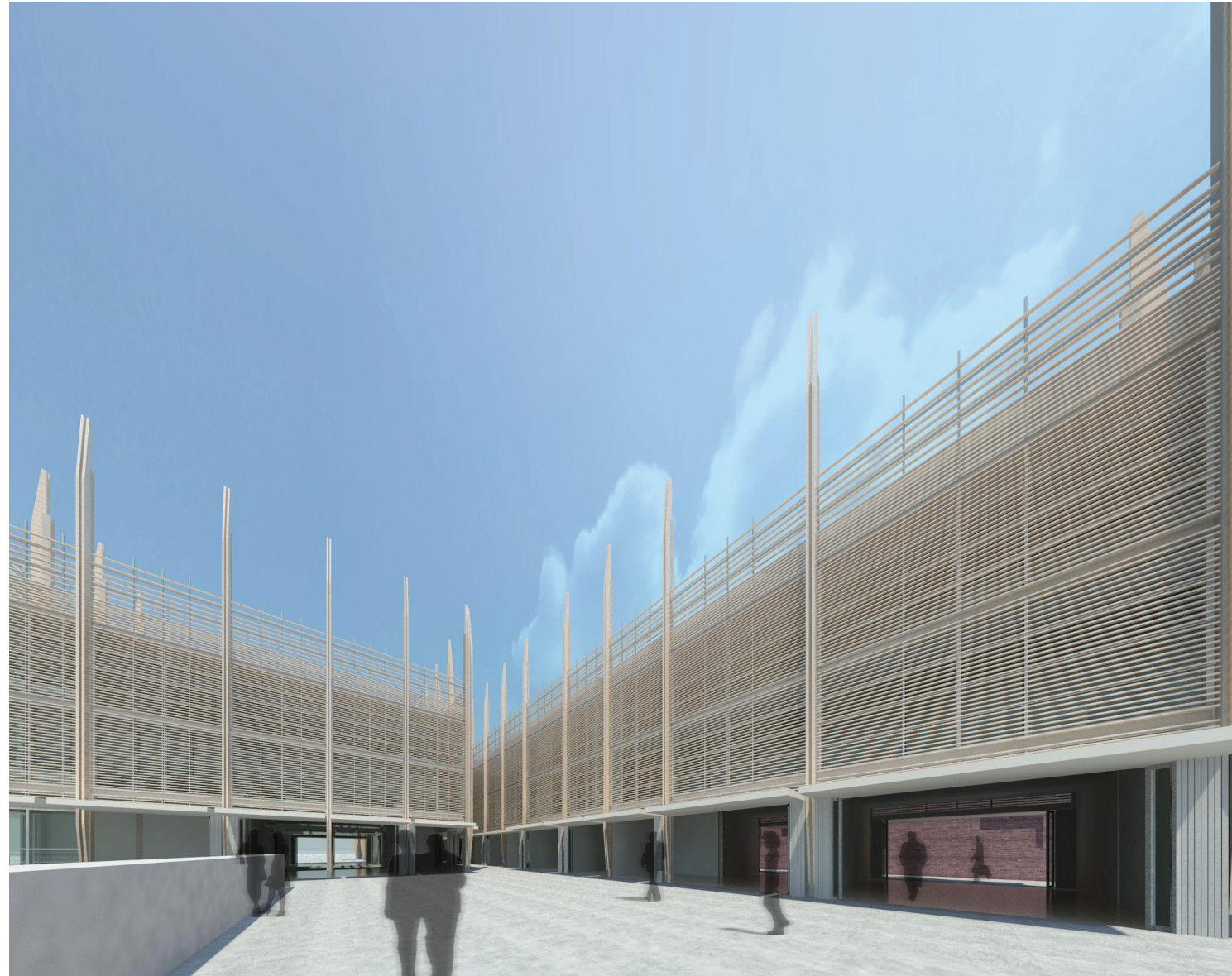

Left: View of the metro entrance plaza - retail spaces are configured to allow views directly through to the space beyond. Along with the use of folding glass doors, this allows the entire ground floor to feel light and permeable. **Right:** Main hotel building's north facade. Its towering spires create a commanding presence while the restaurant's tables spill into the plaza.



This page, left: Seats at the restaurant, located in the main hotel building, are huddled around the closely spaced steel columns supporting the pool on the fourth floor. **Right:** Exposed structure at the courtyard and atrium of the western hotel building.

Facing page, left: At the hotel reception area, visitors assemble under the gallery bridge above. **Right:** On the third floor, the gallery bridge provides a dramatic thoroughfare connecting the gallery's east and west ends through the main hotel building's atrium.





A glass box encloses the winding stairway to the gallery, soaring eastward three floors above.



Left: Visitors to the gallery are greeted with a city view to the east at the reception area.
Right: Skylights allow an even wash of sunlight into the gallery.



Left: The wood slat facade provides both privacy and sunshade for the hotel rooms. **Right:** Midday drinks by the rooftop pool.

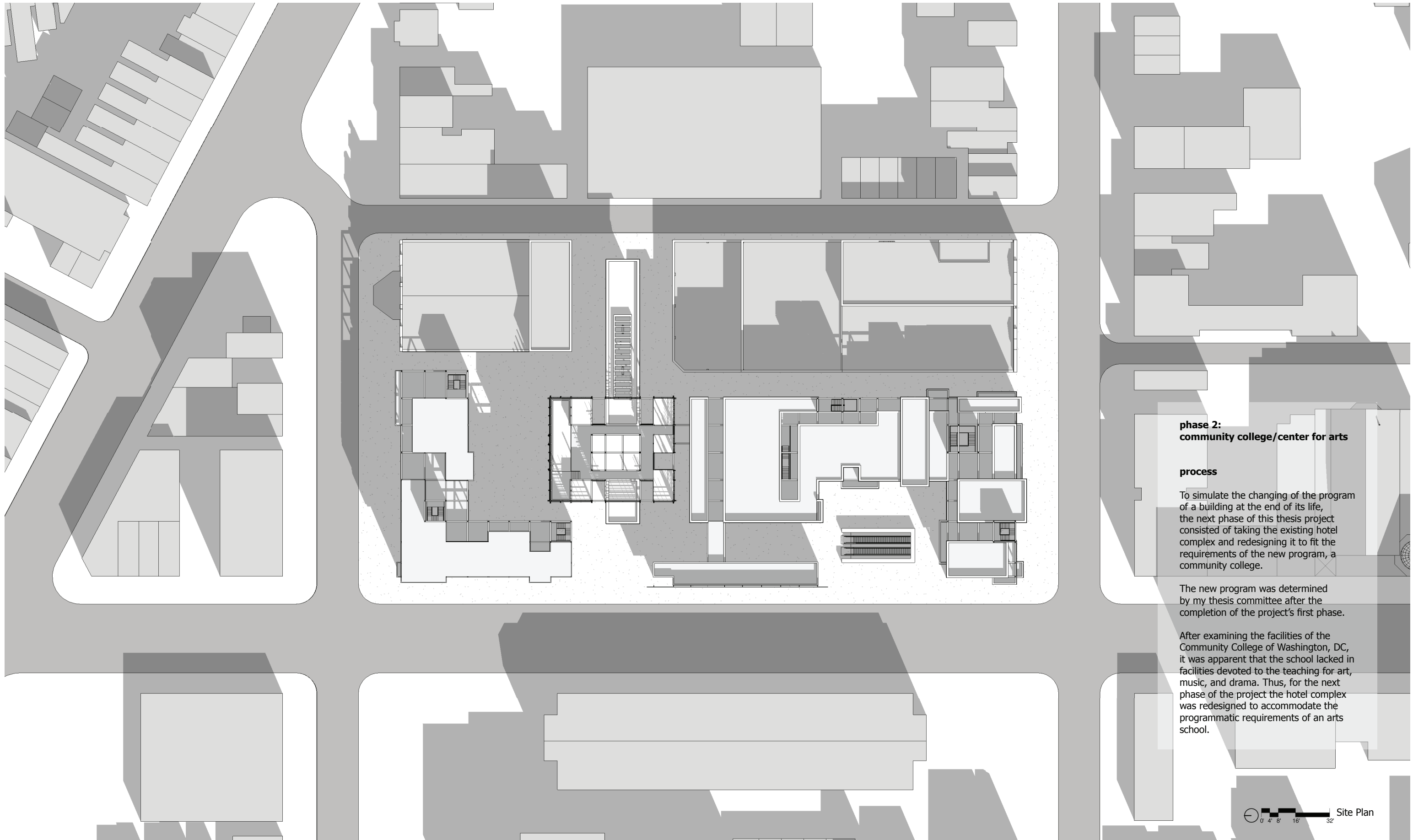

**phase 2:
community college/center for arts**

process

To simulate the changing of the program of a building at the end of its life, the next phase of this thesis project consisted of taking the existing hotel complex and redesigning it to fit the requirements of the new program, a community college.

The new program was determined by my thesis committee after the completion of the project's first phase.

After examining the facilities of the Community College of Washington, DC, it was apparent that the school lacked in facilities devoted to the teaching for art, music, and drama. Thus, for the next phase of the project the hotel complex was redesigned to accommodate the programmatic requirements of an arts school.

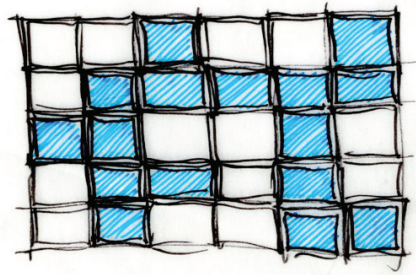

1A

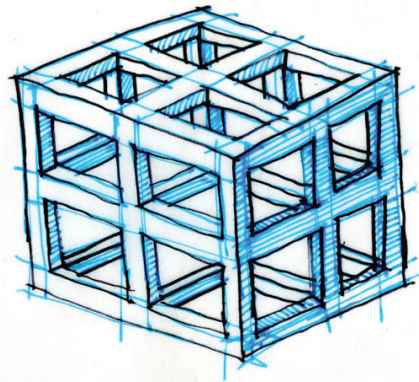

1B

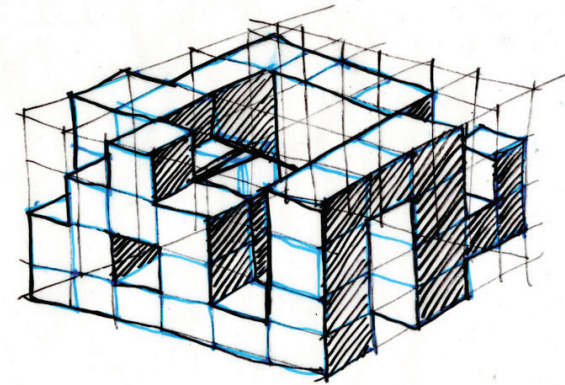

1C

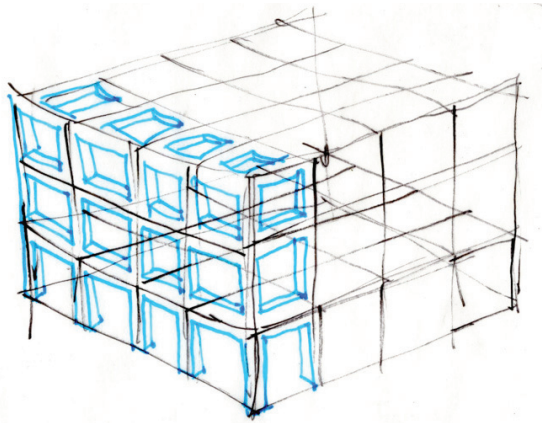

1D

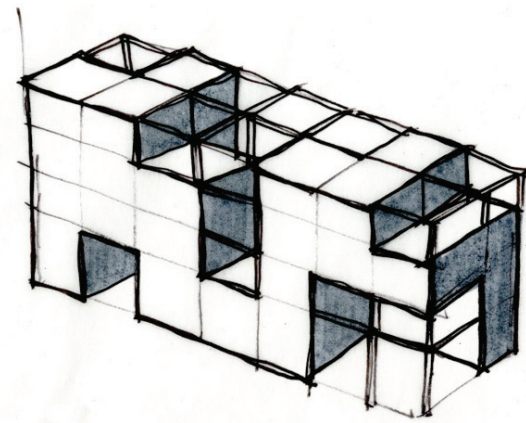

1E

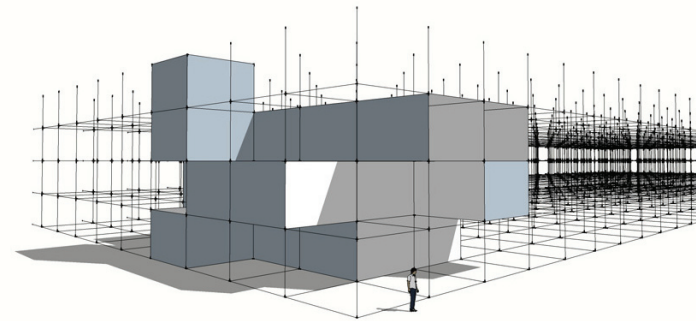

1F

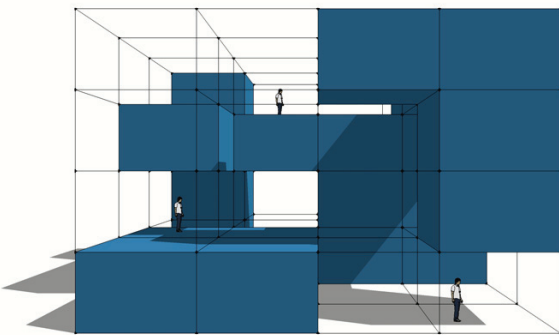

1G

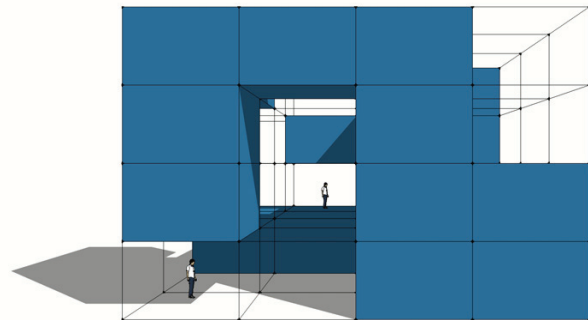

1H

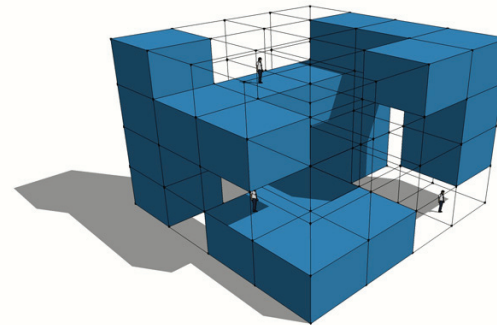

1I

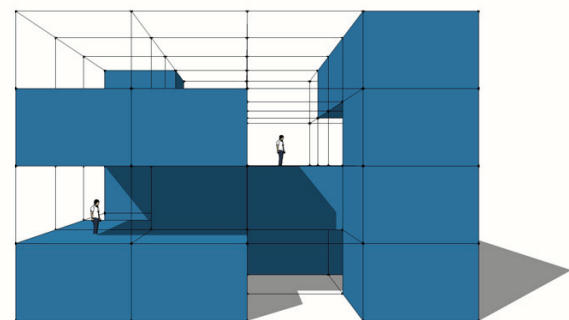

1J

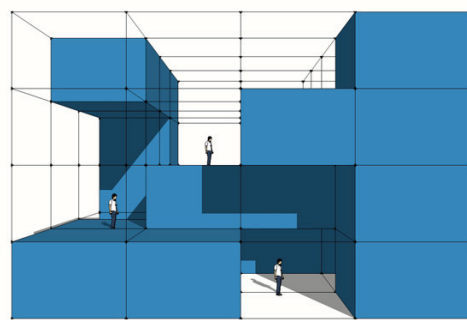

1K

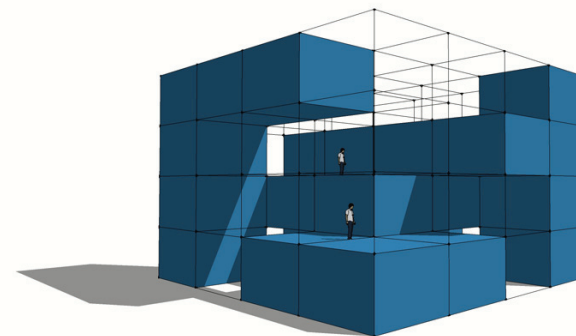

1L

a new design approach

The project's new life required a new way of approaching its design. Because of the use of disassemblable connections in the project's first phase, the entire existing facade could be taken apart and recycled to leave behind the steel frame structure as the bones from which an entirely new design would be created.

The steel frame structure physically represented the 3-dimensional grid that had been applied to the entire site. With its rigid right angles and steel members dividing space into cubes, it felt appropriate to derive the complex's new form from the steel frame structure.

The initial concept for creating the form was the use of the existing structure as a skeleton into which solid cubes could be inserted. By manipulating the spacing of the cubes, an interplay between interior and exterior volumes could be achieved. This also exposed parts of the steel structure, bringing back a strong element in the project's previous life.

1A-1L: Conceptual drawings of block forms. Volumes were added and subtracted to create masses and voids.

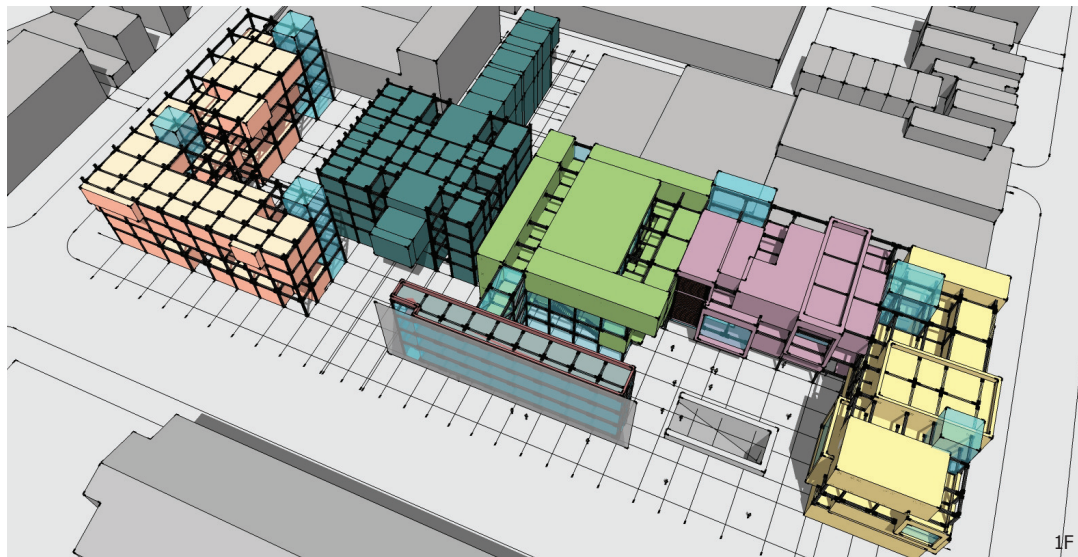
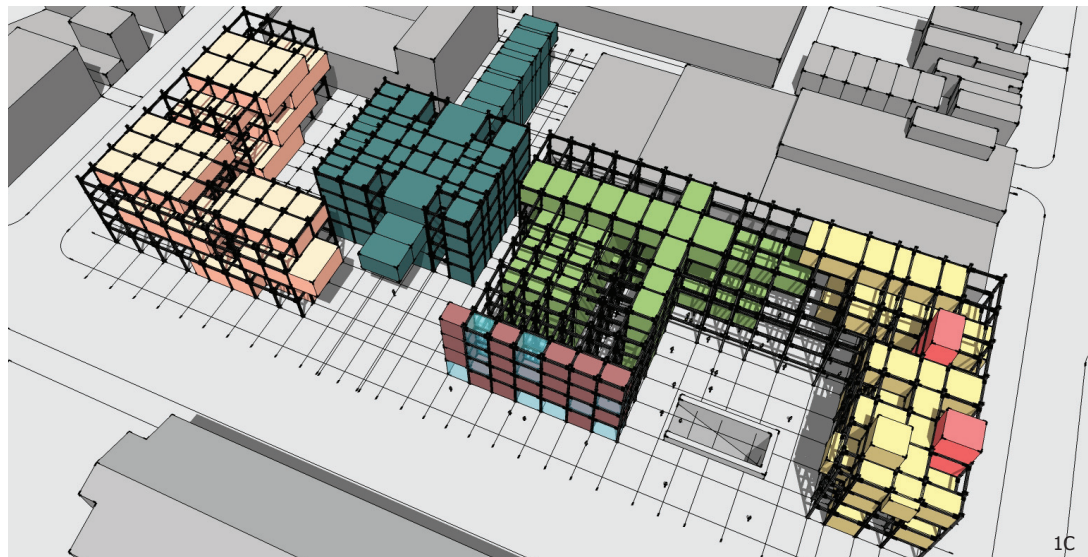
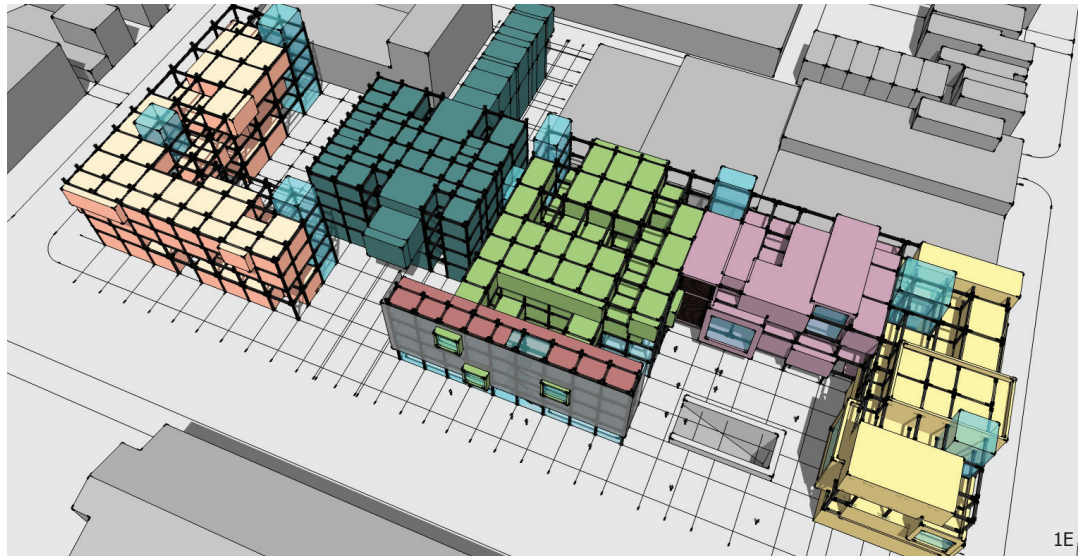
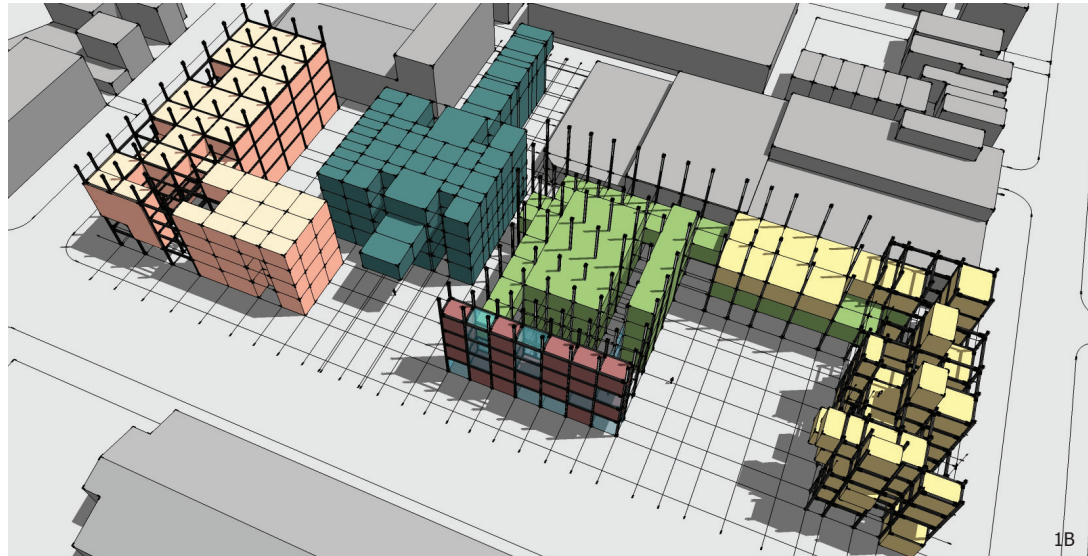
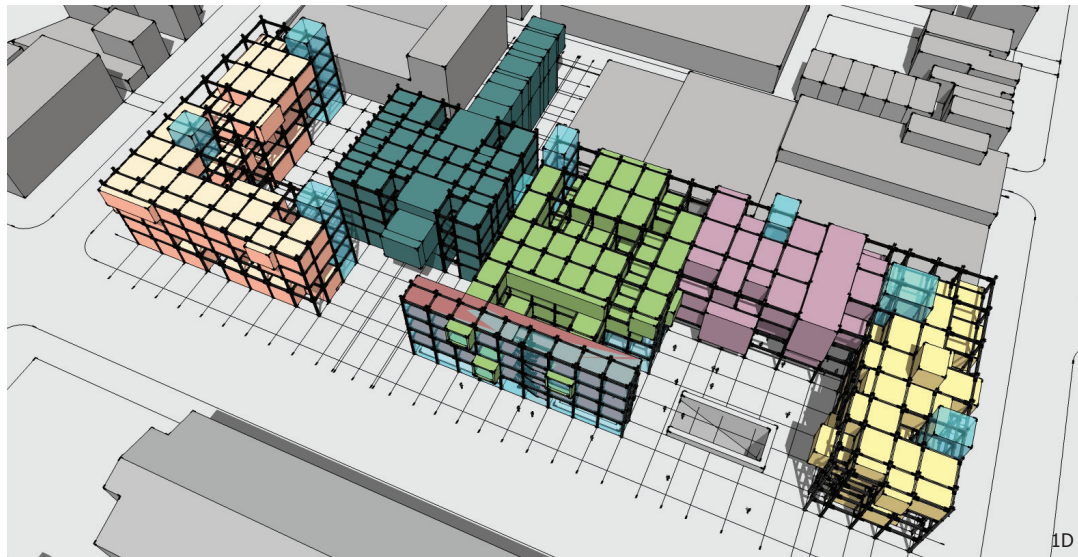
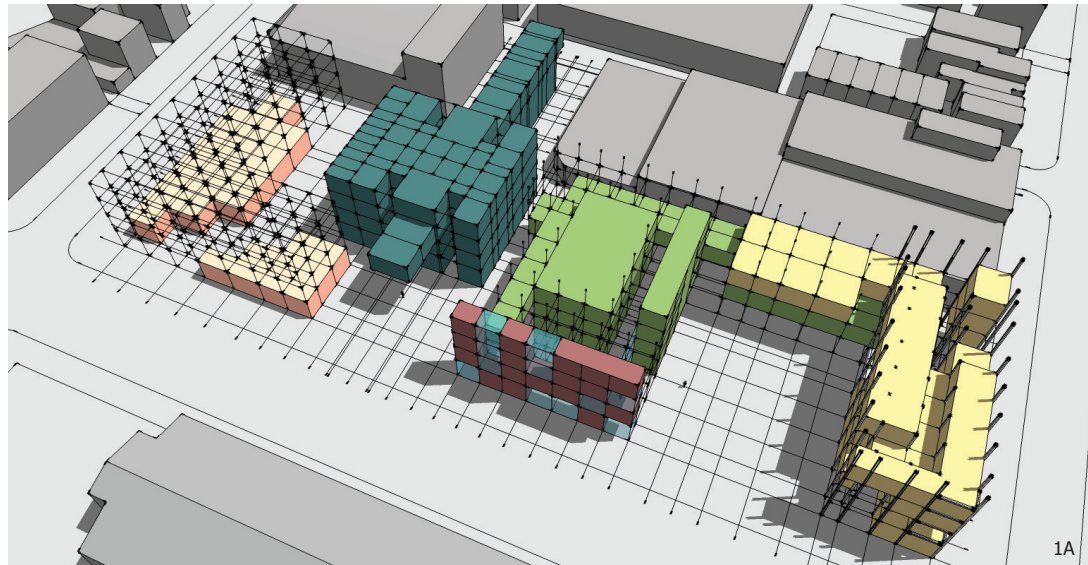

reconfiguring the site

As a branch of a community college, the new project required more space than it did as a boutique hotel. Thus, in addition to rebuilding the hotel buildings themselves, the buildings on the site from the previous project that were not part of the hotel now would become part of the new school.

As a school for the arts, the complex would be designed to accommodate facilities for teaching the visual arts such as painting, drawing, sculpting, installations, digital media, music including vocals and instruments, and theater including drama and dance. The main program elements for the school were an auditorium, a library, classrooms for lectures and workshops, computer rooms, studios for visual arts and theater instruction, recording studios, study rooms, faculty offices, and student housing.

In a gesture of respect to the project's previous life, the main building of the old hotel was preserved as the administrative building for the school. It would now house administrative rooms and offices, and its other functions during its time as a hotel building, such as the restaurant, conference rooms, pool and fitness room, would now be available for student and faculty use. The floating gallery would also be kept intact to showcase both student work and the work of local artists.

The rest of the site would be rebuilt from the existing structure and adopt the form of cubed volumes in order to achieve a sense of unity among the school complex's various buildings.

Using the existing structure also meant that the original locations of the plazas would be preserved. From a pragmatic standpoint, it made more sense to adhere to the original spatial configuration of the site rather than dramatically detract from it, while still allowing the option of adding and/or subtracting structural members as required.

1A-1F: Massing studies arranged in chronological order of development.

Key

- Student Housing Building
- School Administration Building
- Auditorium Building
- Study Room Building
- Classroom Building 1
- Classroom Building 2

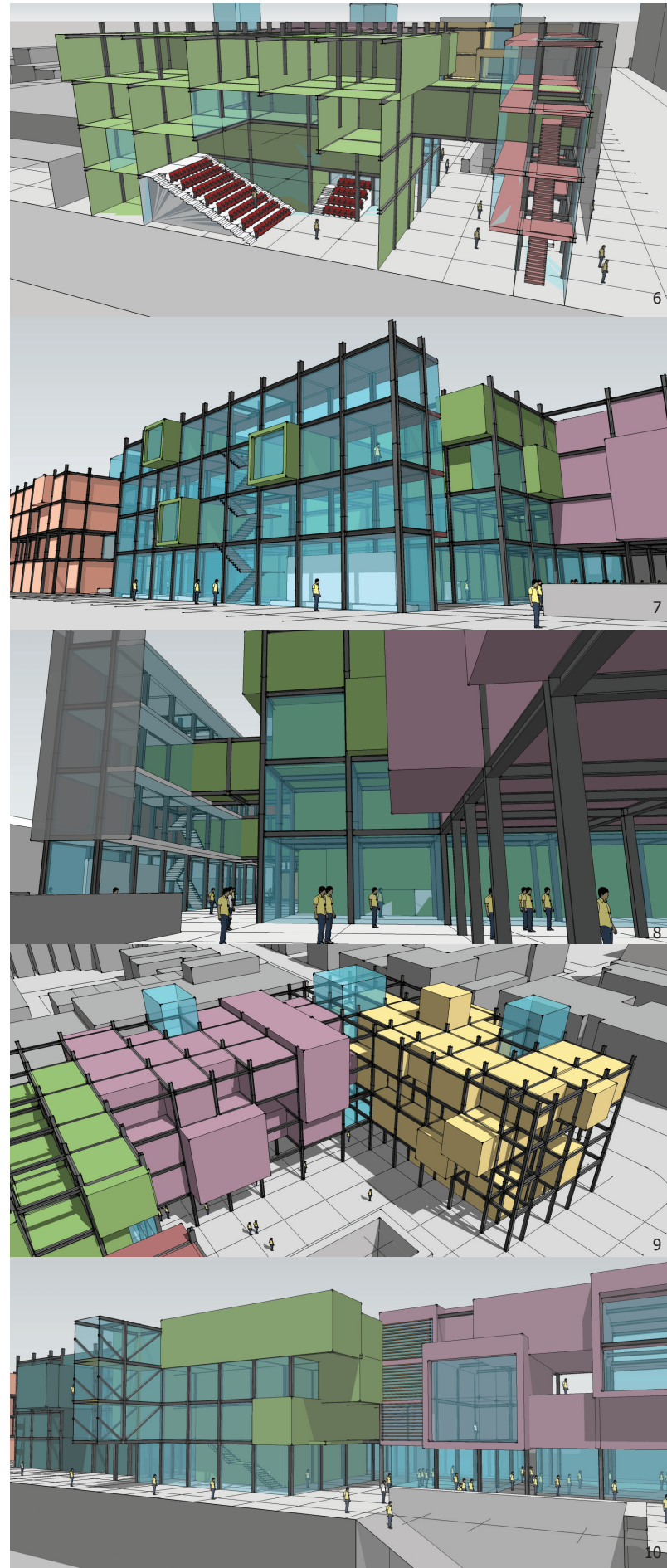
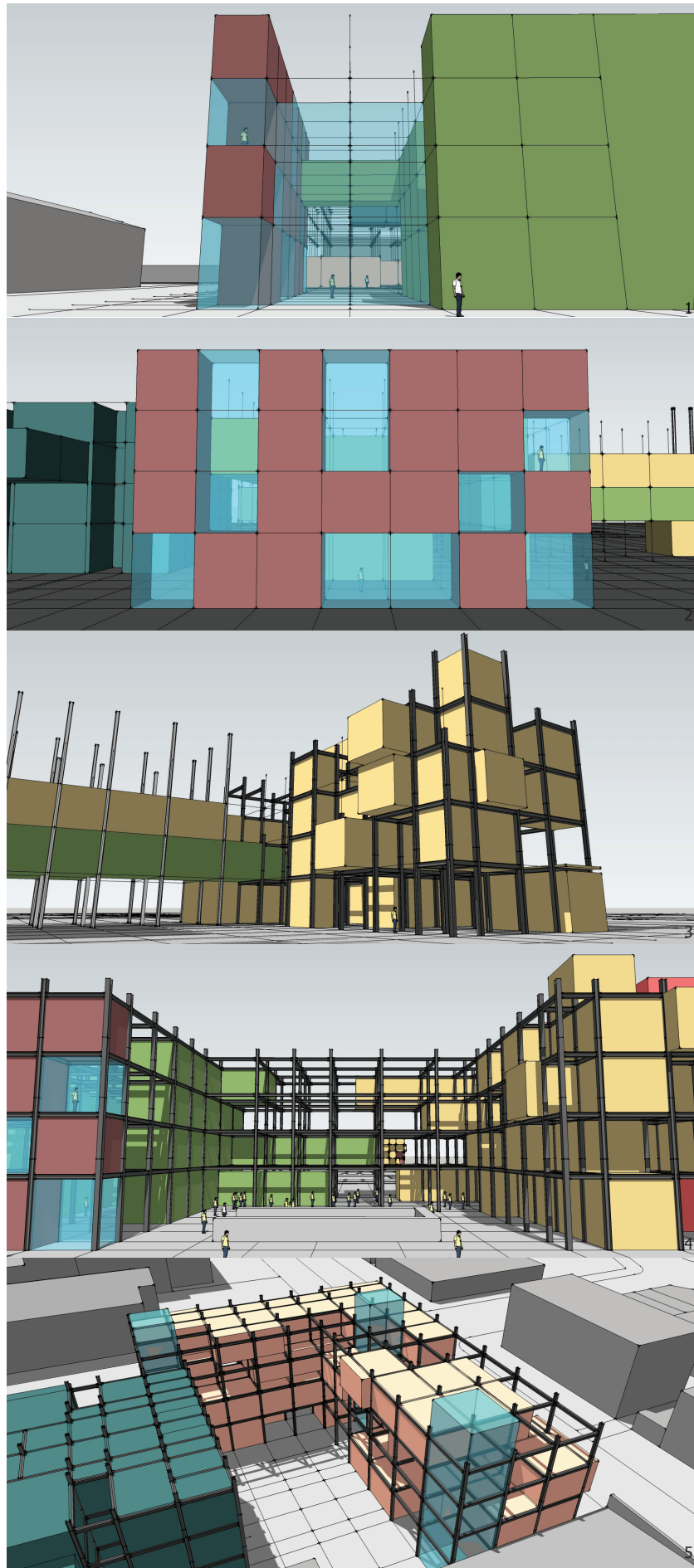

reconfiguring the site, cont'd

The new complex's buildings were assigned a location on the site in accordance with their programs. The northern end of the site was designated as the student housing building because of its proximity to the new school administration building, which houses many non-academic student-related functions. Unfortunately due to time constraints, the student housing building was developed only partially, and the project focused more on the development of the academic related functions of the new school.







The buildings south of the new school administration building would contain the academic programs such as the classrooms, studios, auditorium, etc. Originally conceived as separate buildings, they are connected by multiple paths of circulation.

The ground floor level was kept permeable both visually and physically with glass boxes enclosing spaces such as workshops, the auditorium building lobby, and the display area for student work. This promotes pedestrian traffic through the site while allowing glimpses into the school's activities.

On the upper levels, the concept of cubed volumes was further developed into a language of shifting blocks. Larger volumes such as the studios and smaller classroom volumes slide past one another to create an unconventional floor plan with winding hallways and unexpected balconies.

1: View from Metro escalators. The initial concept for the auditorium building entry was a glazed hallway that connected the Metro plaza and the school administration building. **2:** Early concept for study room building. **3:** Development of classroom block form. **4:** View of metro plaza. Blocks projecting from the auditorium building and the first classroom building converge at the Metro plaza and begin to form the second classroom building. **5:** The student housing building adopts the same type of block form as the other buildings on the site. **6:** Section study through auditorium and study room buildings. **7:** Further developed study room building. Circulation paths from the auditorium building project forward and through the study room building, now entirely glazed. **8:** The ground floor area under the second classroom building was initially a completely open space similar to a covered plaza. **9:** Further developed classroom buildings, which were configured to include the larger studio volumes. **10:** Section study through bridge showing pathway from Metro escalators.

Key

 Student Housing Building	 Study Room Building
 School Administration Building	 Classroom Building 1
 Auditorium Building	 Classroom Building 2

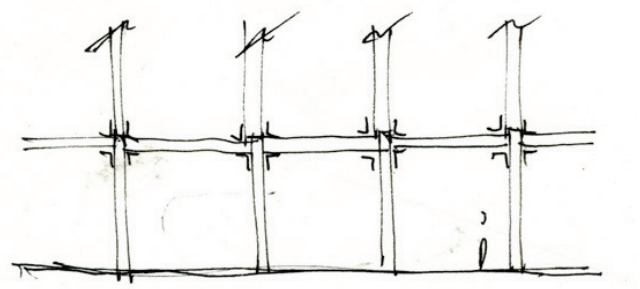

1A

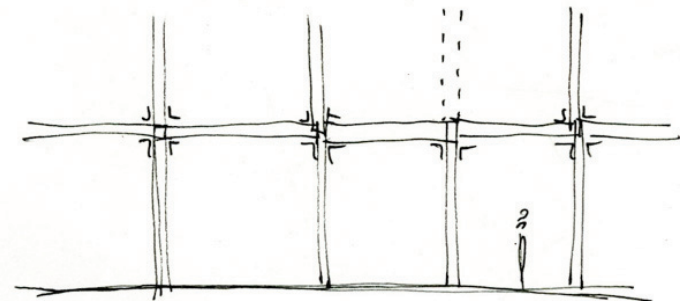

1B

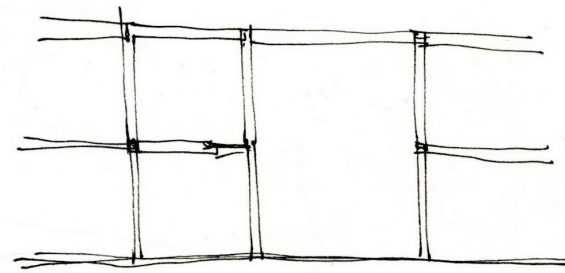

1C

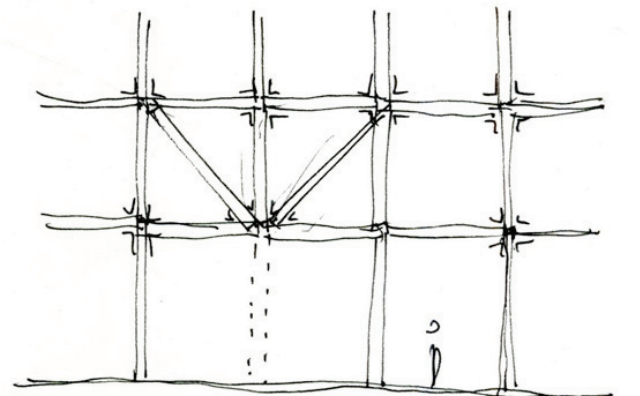

1D

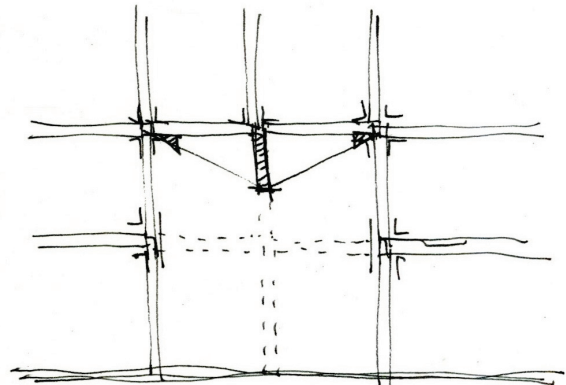

1E

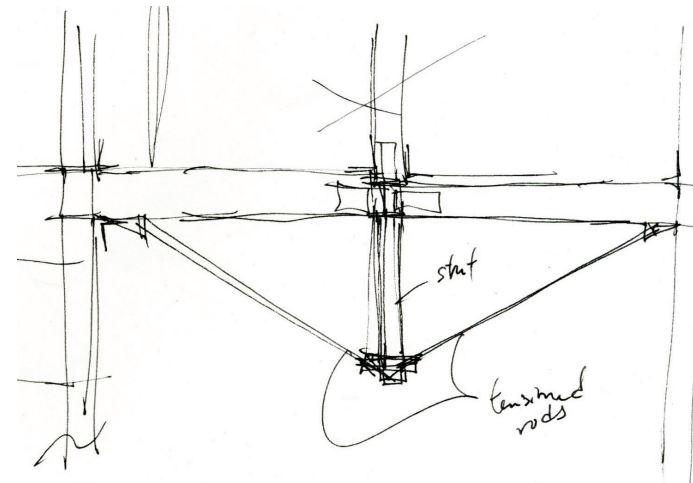

2A

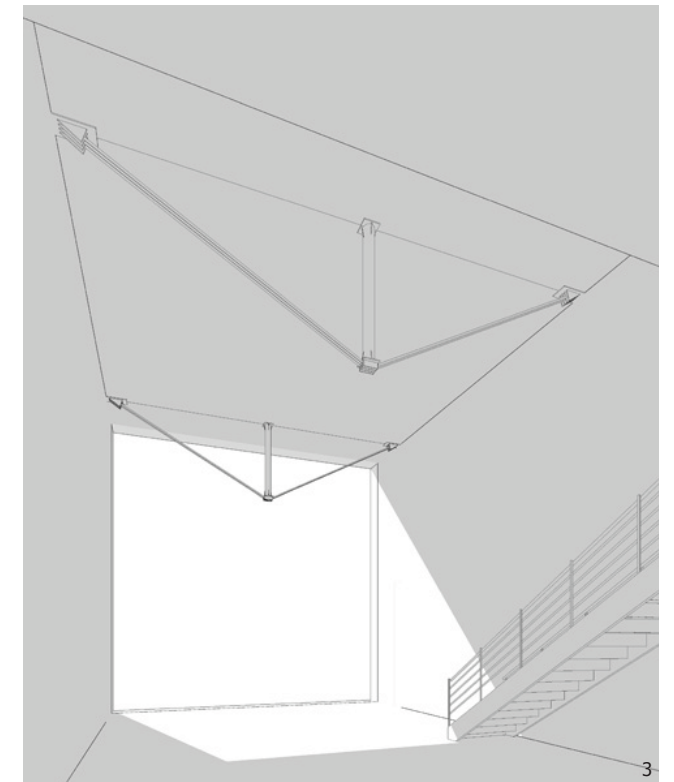

3

manipulating the existing steel frame

A critical part of working with the existing structure was the introduction of program that required large, unobstructed spaces. Unlike the hotel, which consisted mostly of small rooms, the new arts school will need airy, double storey spaces, preferably free of columns.

The use of bolted connections allowed columns and beams to be removed for just this purpose. In situations where the load path of a column was interrupted by the removal of the column below it, two strategies were employed to transfer the load to adjacent columns: diagonal bracing members and inverted king posts supported by tensioned cables.

For the lofty studios, the king posts are an elegant solution to the removal of existing structure and make a dramatic structural feature that emphasizes the volume of a space.



2B

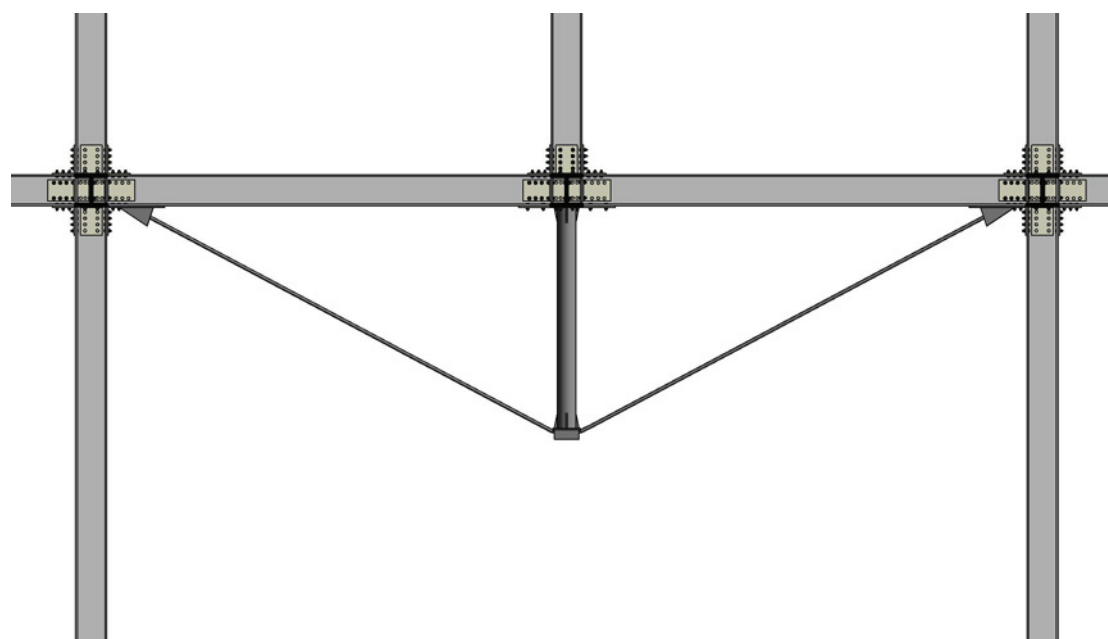

2C

1A-1E: Study of varying structural conditions found within the project. **2A-2C:** The inverted king post truss members are bolted to the existing structure and held in place by tensioned cables. **3:** Study of a studio interior with a trussed ceiling.

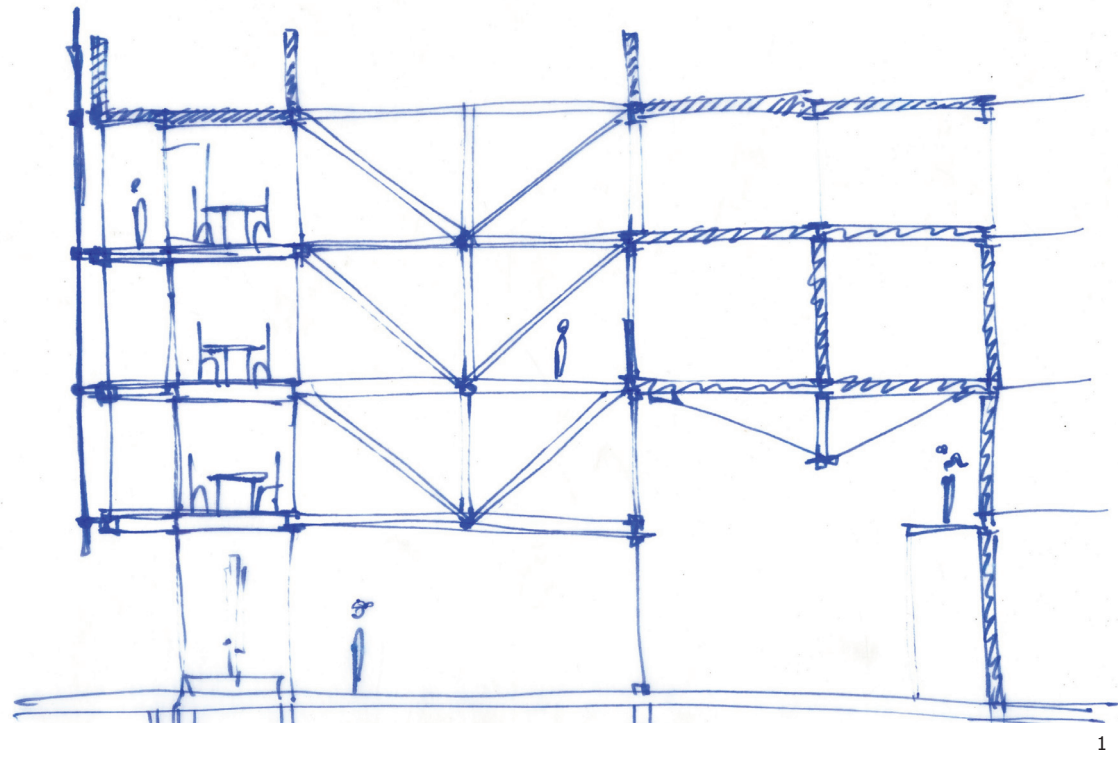

1

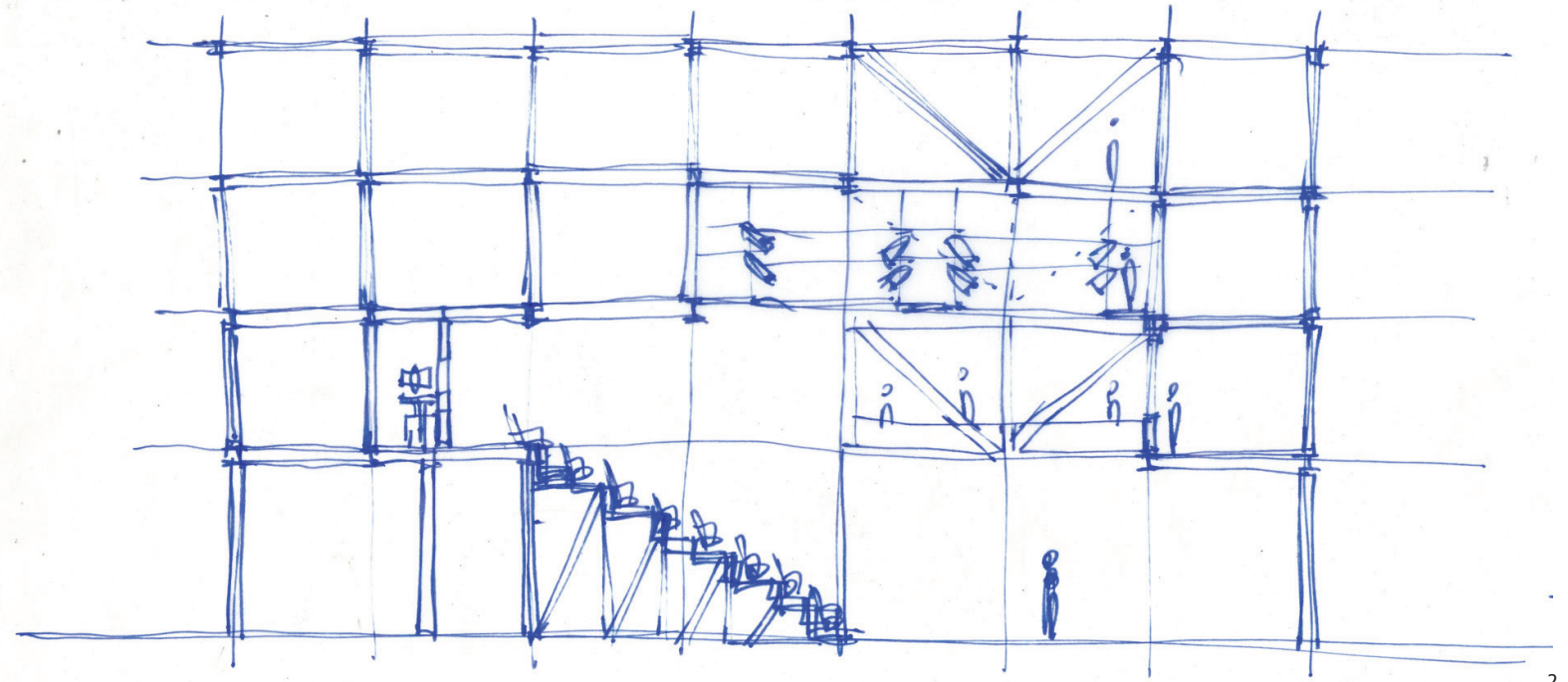

2

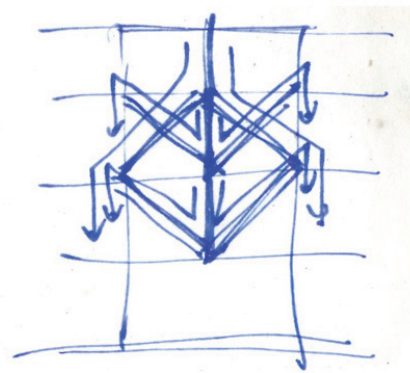

3A

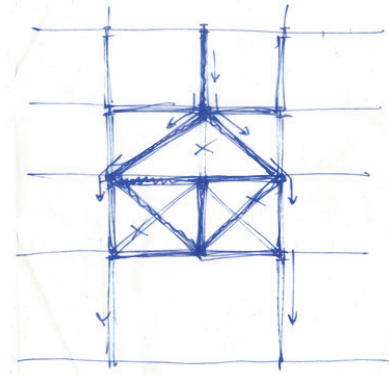

3B

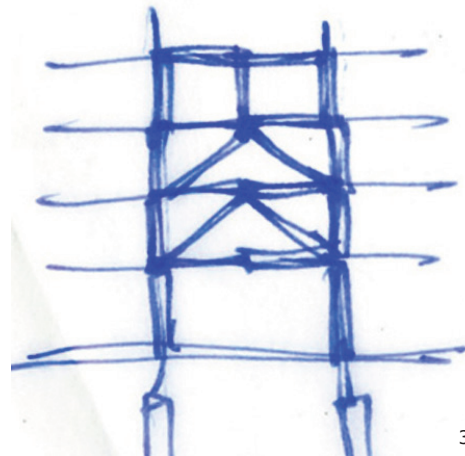

3C

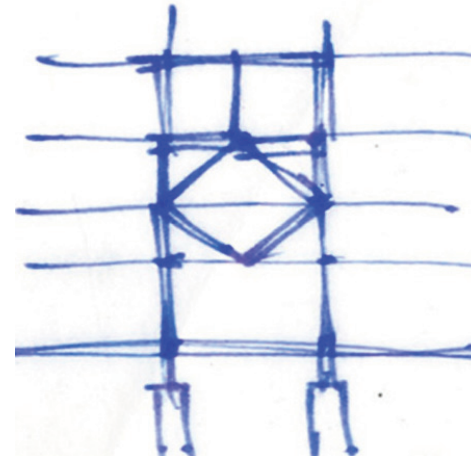

3D

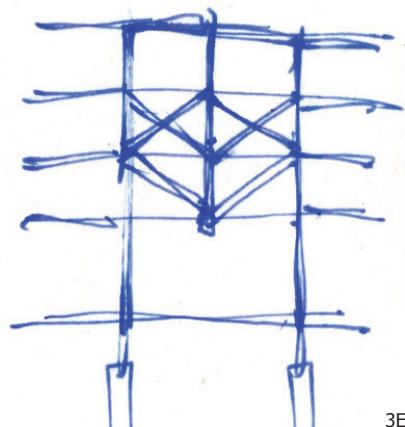

3E

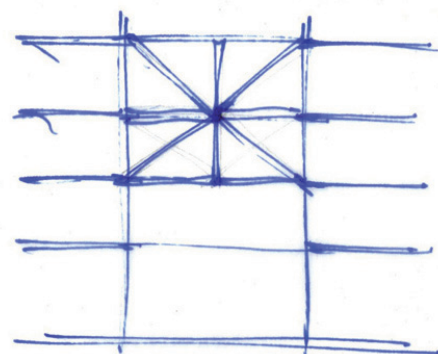

3F

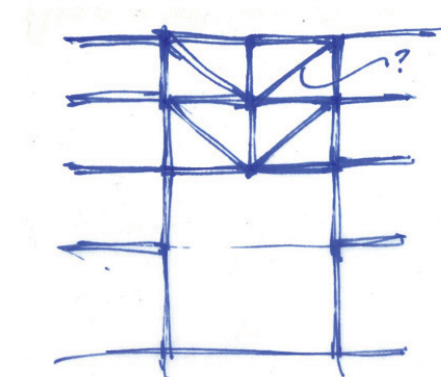

3G

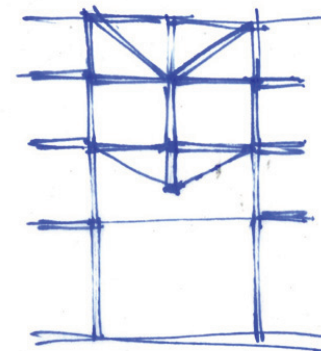

3H

manipulating the existing steel frame, cont'd

Various methods of implementing diagonal bracing were studied before one was chosen, using criteria such as the direction of load transfer, obstruction of circulation, and structural expression as important deciding factors.

A system similar to the Pratt truss, which uses vertical members for compression and diagonal members for tension, proved to be the most appropriate method for specific areas of the project such as the three-storey bridge connecting the auditorium building to the study room building and the auditorium.

1: Section sketch through study room building and auditorium lobby, with diagonal bracing at the bridge. **2:** Section sketch through auditorium, with diagonal bracing on auditorium walls. **3A-3H:** Diagrams of various diagonal bracing systems.

phase 2:
Final Drawings

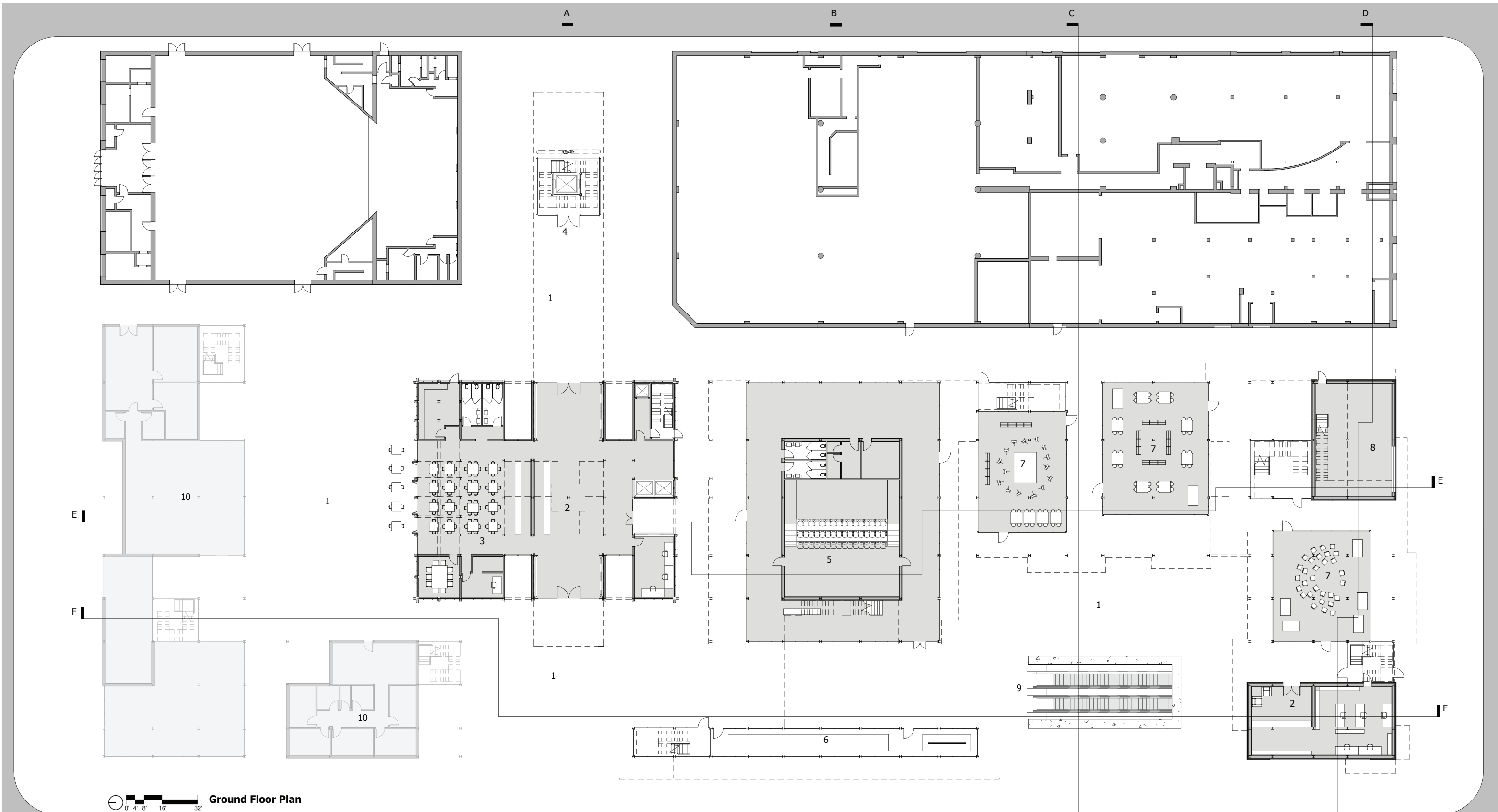

Ground Floor Plan

- 01 Plaza
- 02 School Administration
- 03 Restaurant
- 04 Art Gallery Entrance
- 05 Theater/Auditorium
- 06 Display Area
- 07 Workshop
- 08 Studio
- 09 Shaw/Howard Metro Entrance
- 10 Student Housing Building

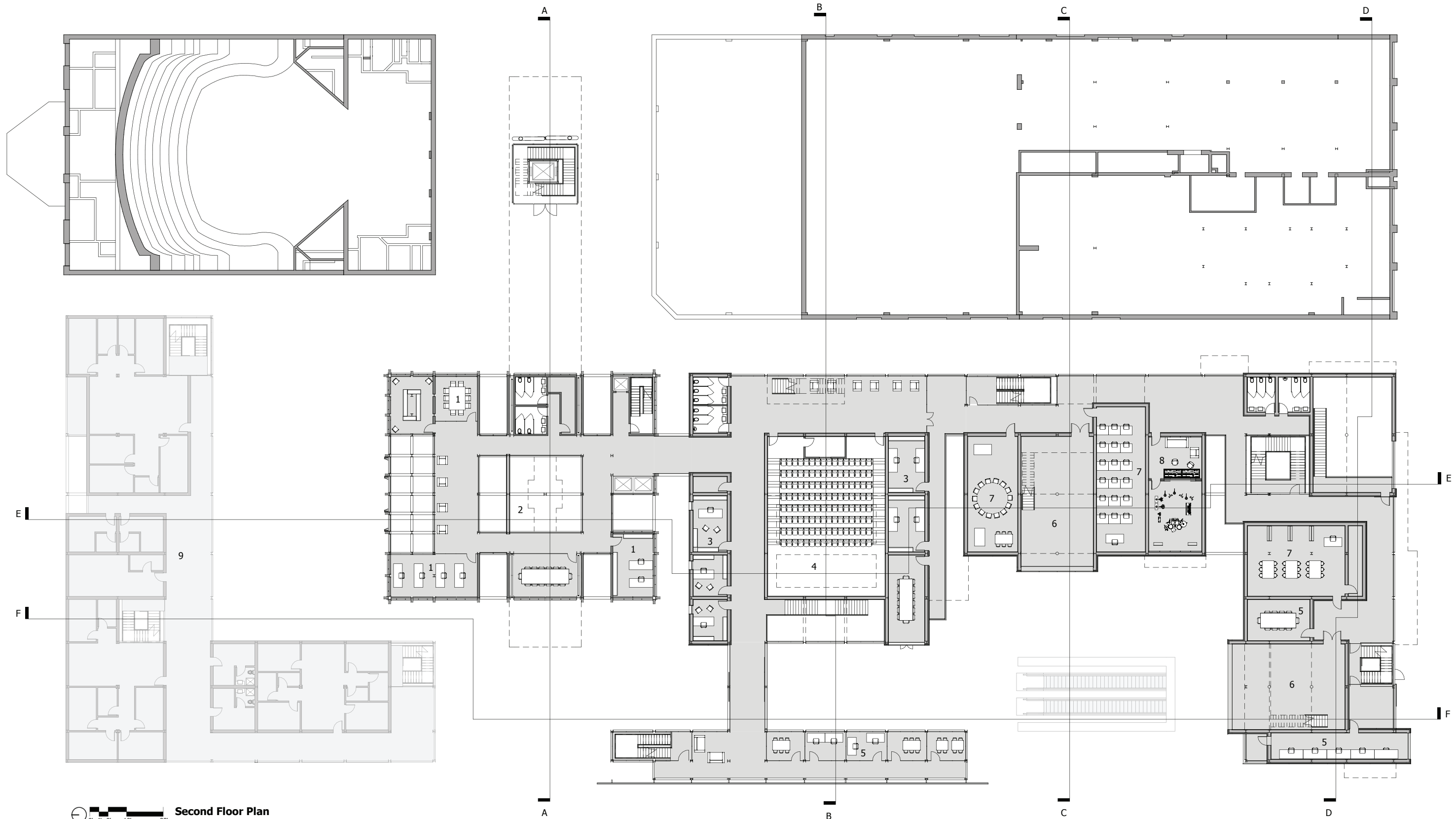

Second Floor Plan

- 01 Administrative Offices
- 02 Atrium
- 03 Faculty Offices
- 04 Theater/Auditorium
- 05 Study Rooms
- 06 Studio
- 07 Classroom
- 08 Recording Studio
- 09 Student Housing Building

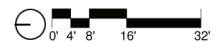
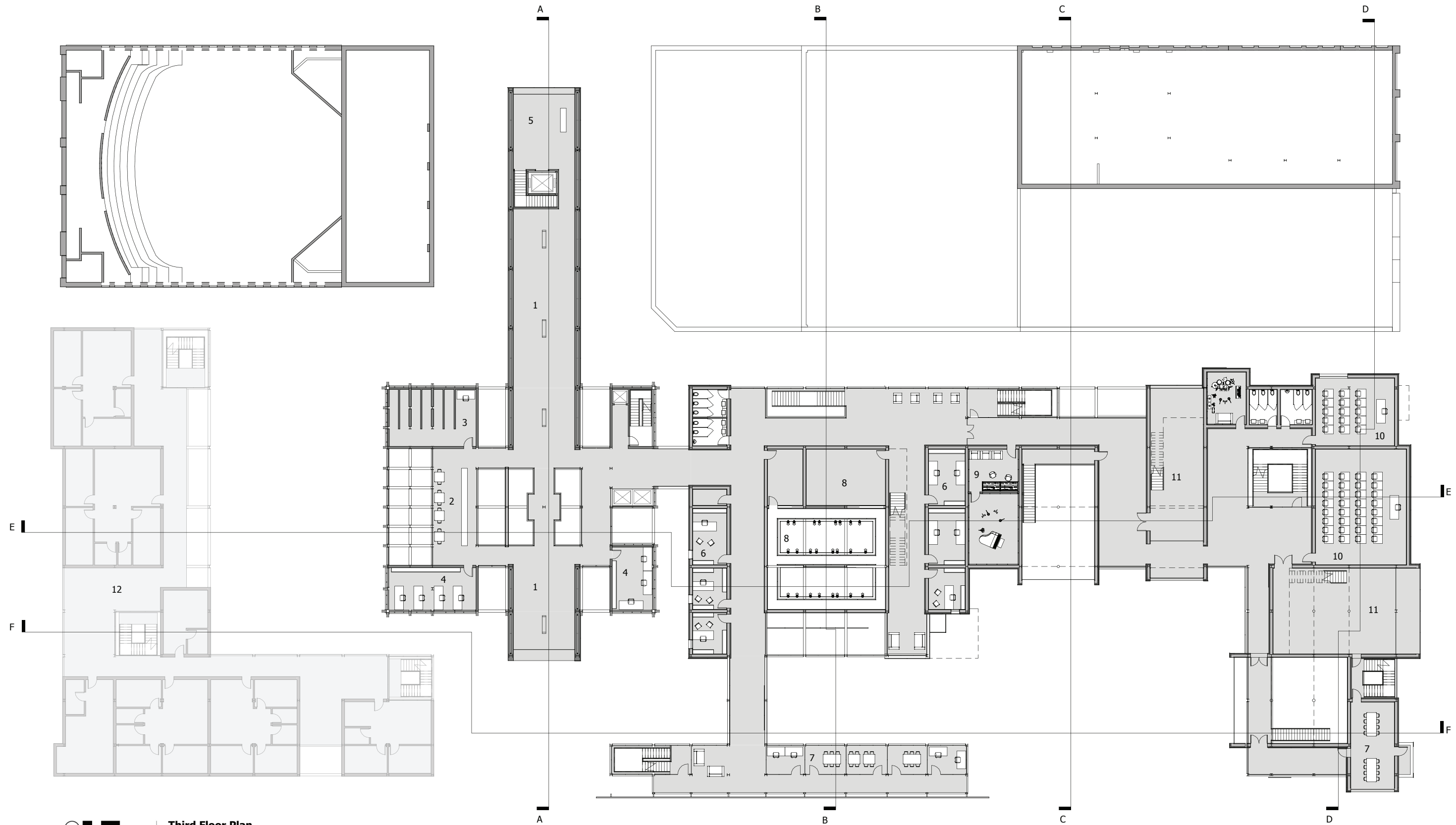

Third Floor Plan

- | | |
|----------------------|-----------------------------|
| 01 Art Gallery | 07 Study Rooms |
| 02 Gallery Cafe | 08 Theater Support |
| 03 Gallery Storage | 09 Recording Studio |
| 04 Gallery Offices | 10 Classroom |
| 05 Gallery Reception | 11 Studio |
| 06 Faculty Offices | 12 Student Housing Building |

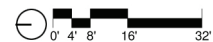
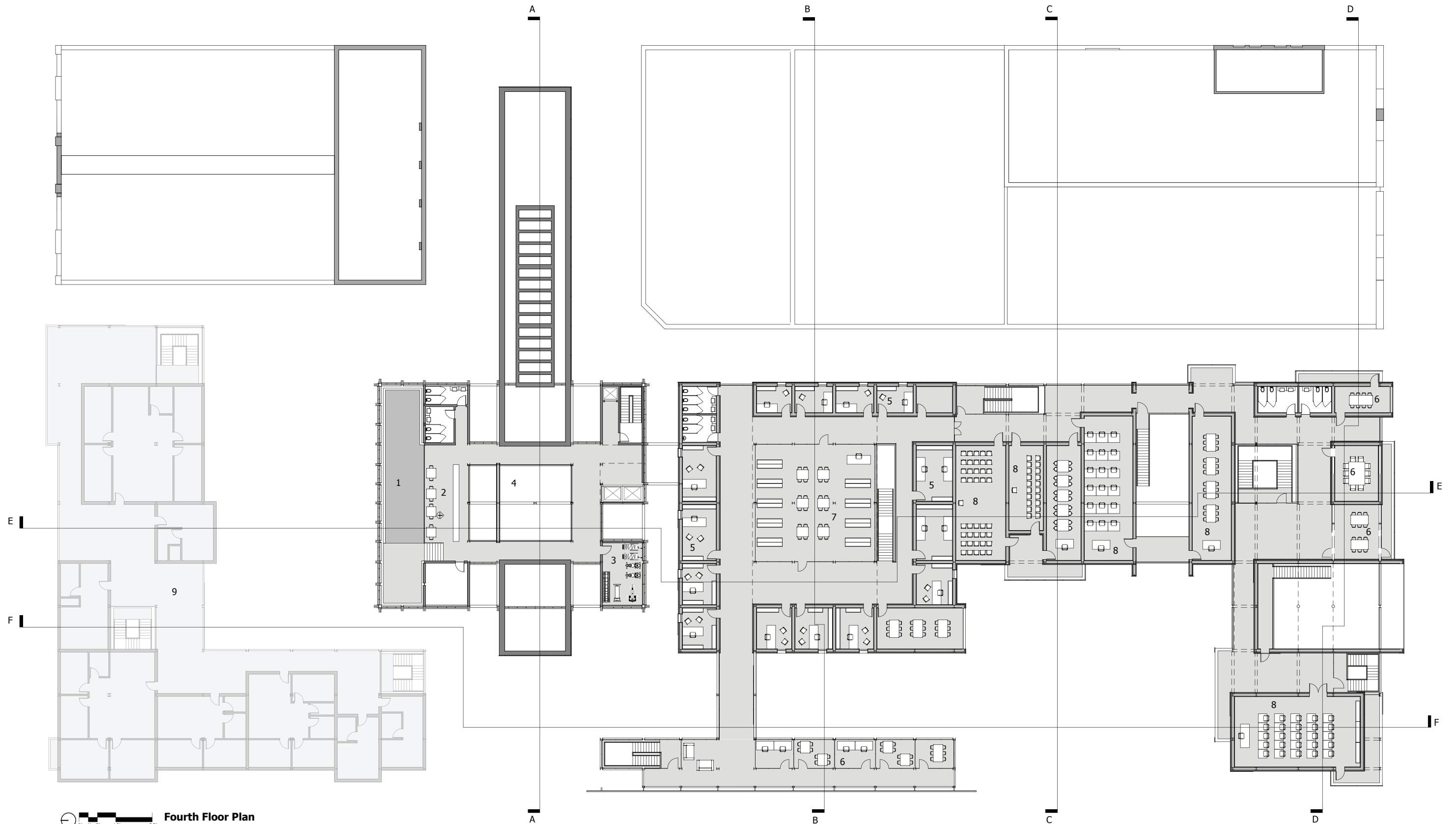

Fourth Floor Plan

- 01 Pool
- 02 Pool Bar
- 03 Fitness Room
- 04 Atrium
- 05 Faculty Offices
- 06 Study Rooms
- 07 Library
- 08 Classroom
- 09 Student Housing Building

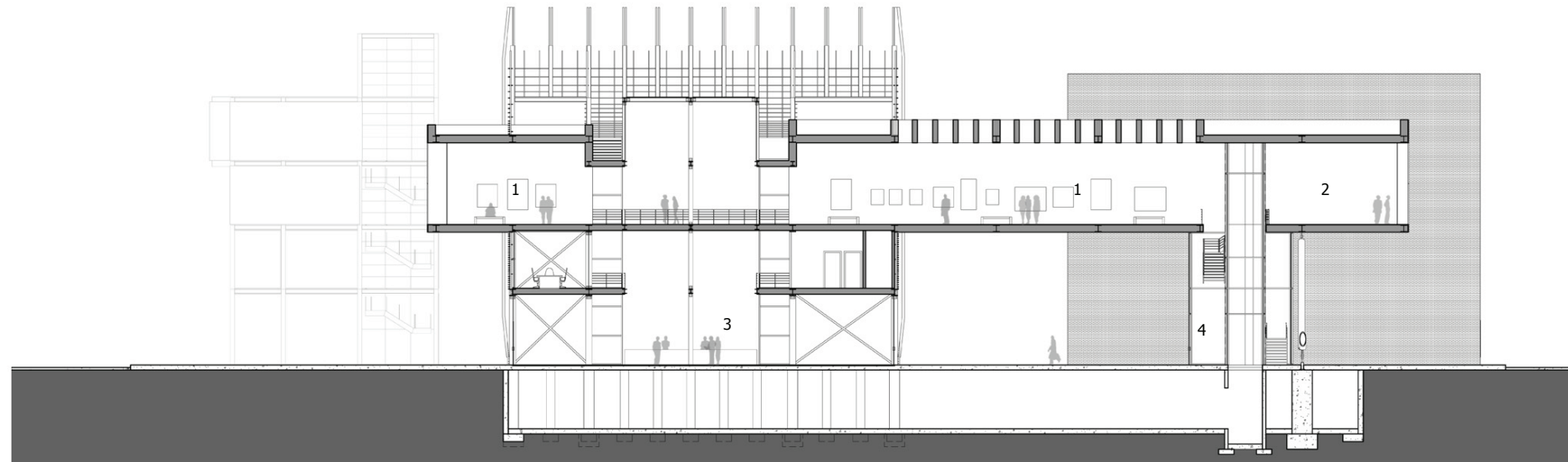

Section A-A

- 01 Art Gallery
- 02 Gallery Reception
- 03 School Administration Reception
- 04 Gallery Entrance

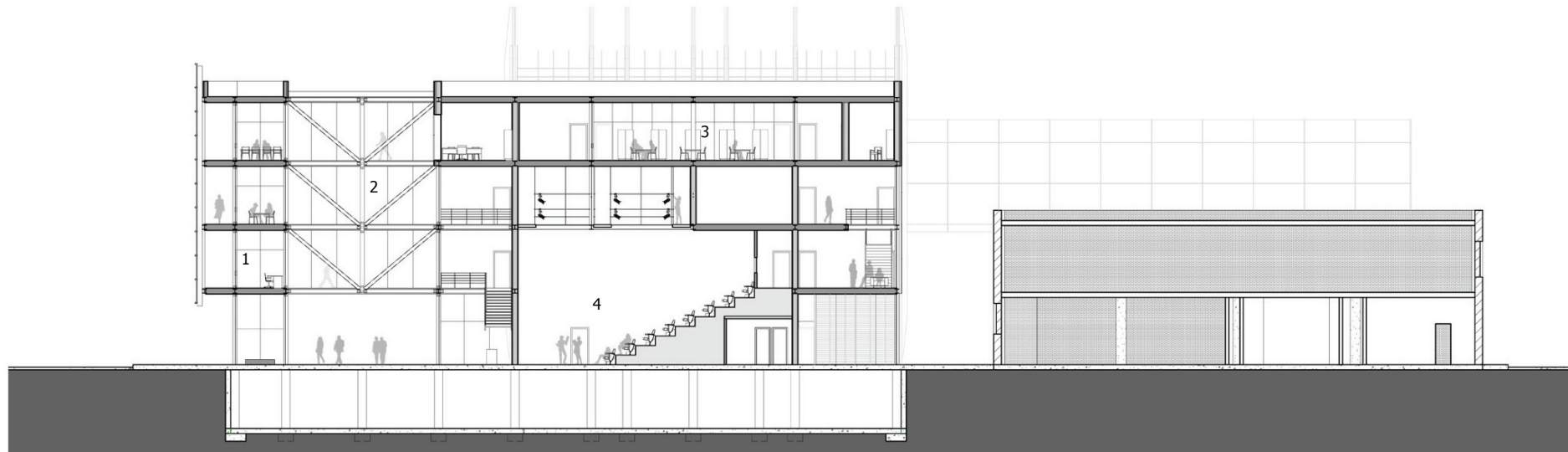

Section B-B

- 01 Study Rooms
- 02 Bridge
- 03 Library
- 04 Theater

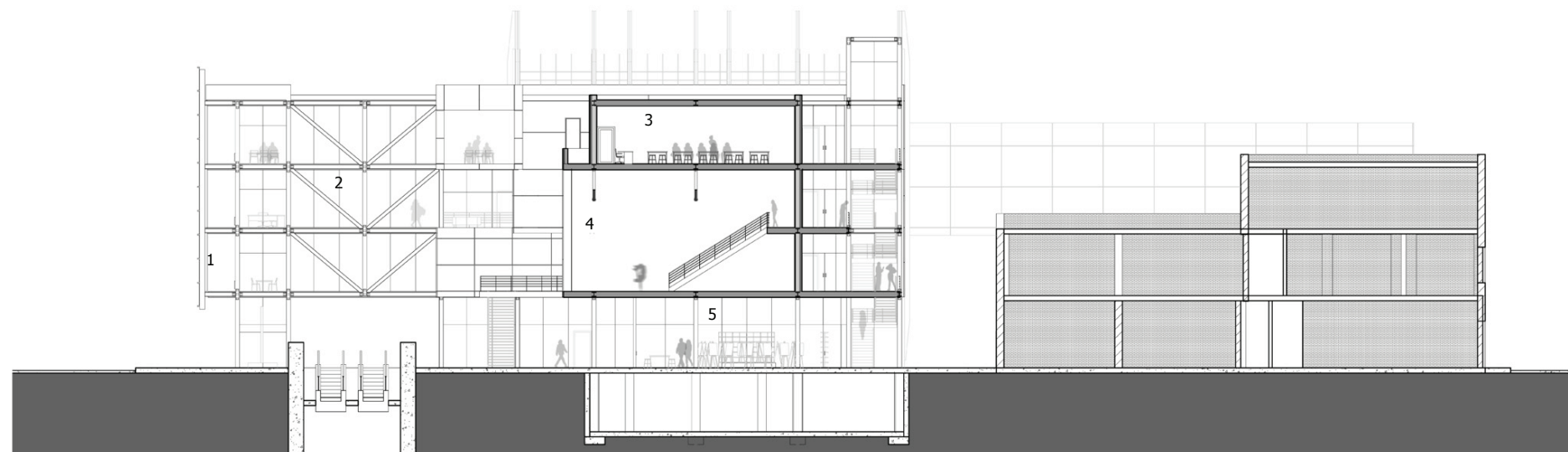

Section C-C

- 01 Study Rooms
- 02 Bridge
- 03 Classroom
- 04 Studio
- 05 Workshop

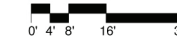

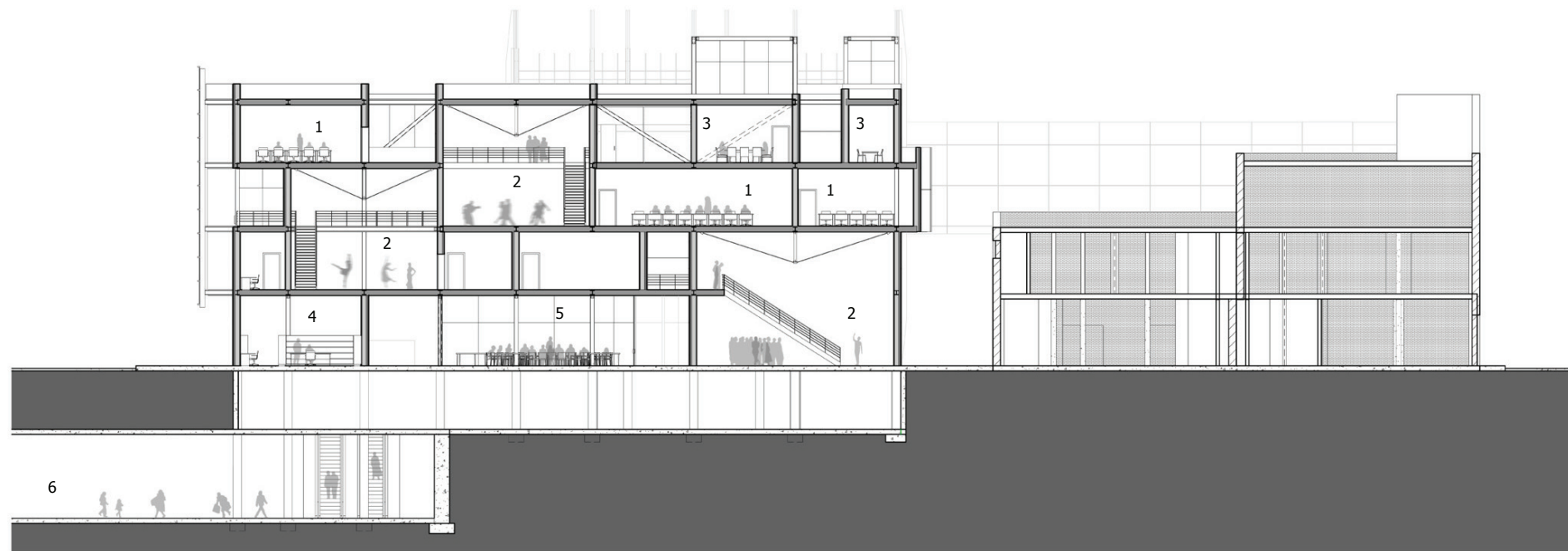

Section D-D

- 01 Classroom
- 02 Studio
- 03 Study Room
- 04 School Administration
- 05 Workshop
- 06 Shaw/Howard Metro Entrance

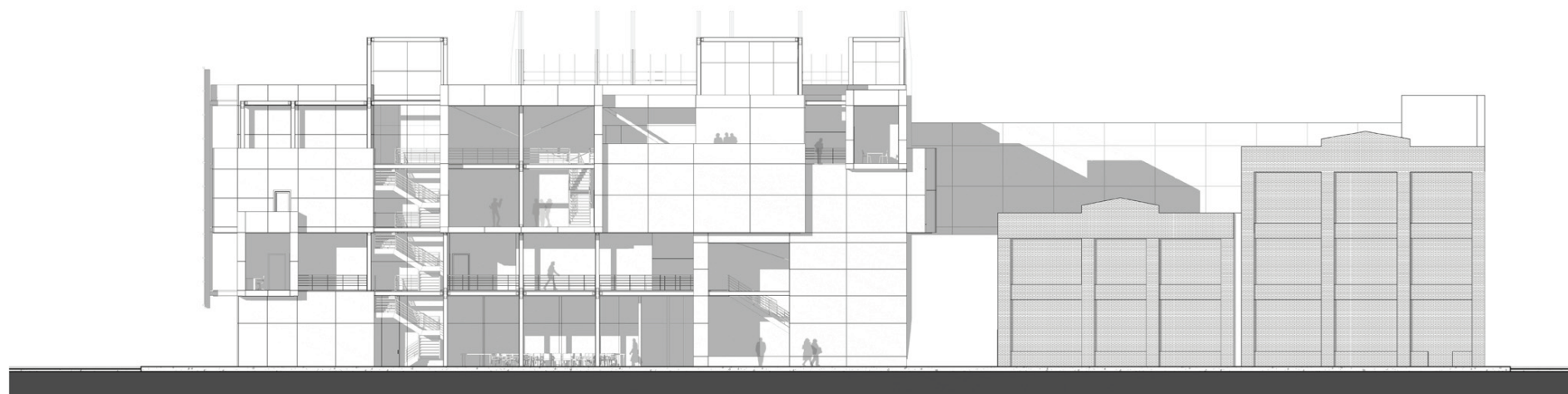

South Elevation



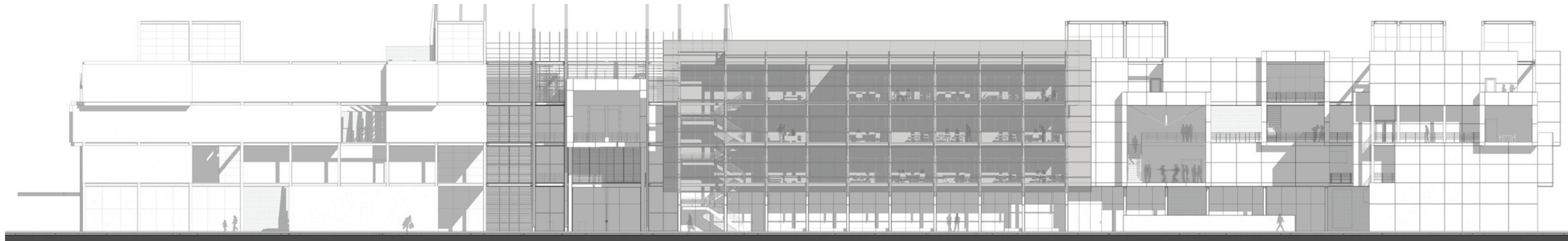

West Elevation

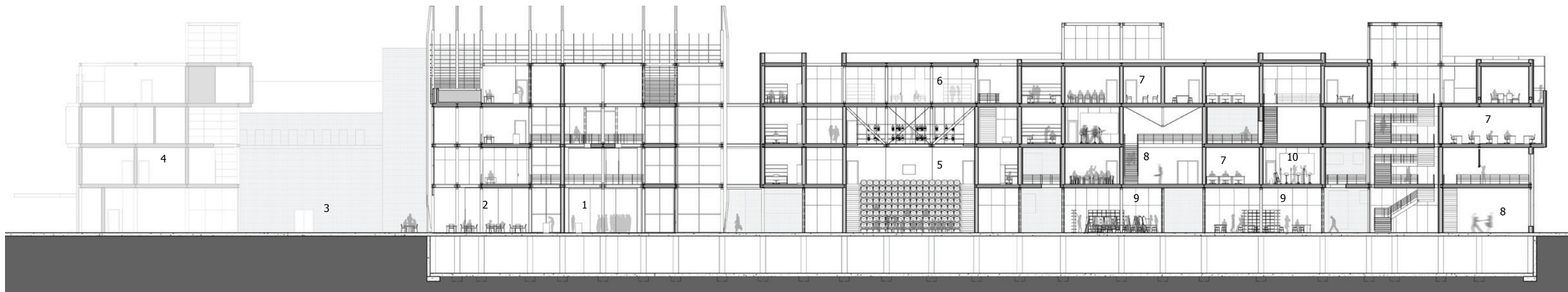

Section E-E

- 01 School Admin. Reception
- 02 Restaurant
- 03 Plaza
- 04 Student Housing
- 05 Theater/Auditorium
- 06 Library
- 07 Classroom
- 08 Studio
- 09 Workshop
- 10 Recording Studio

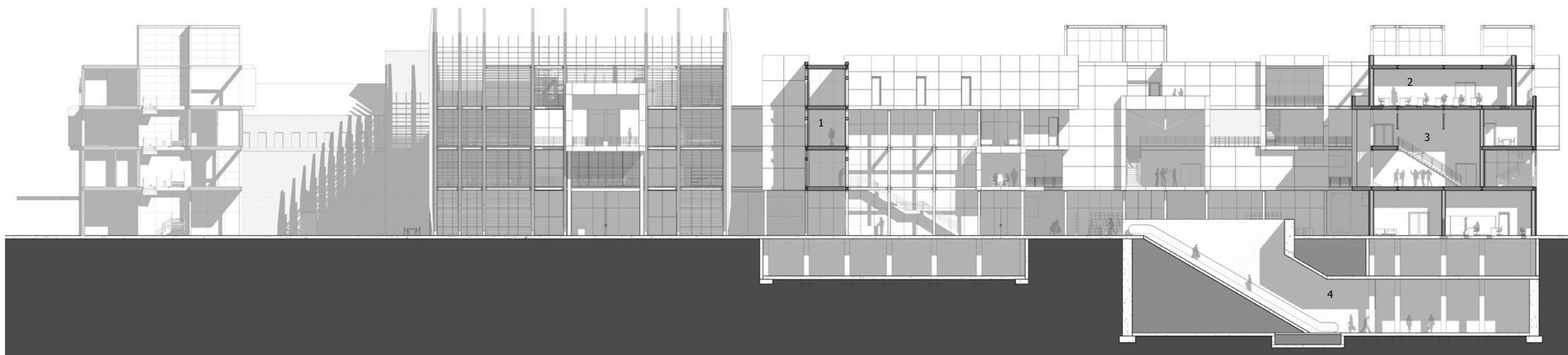

Section F-F

- 01 Bridge
- 02 Classroom
- 03 Studio
- 04 Shaw/Howard Metro Entrance

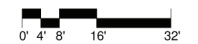

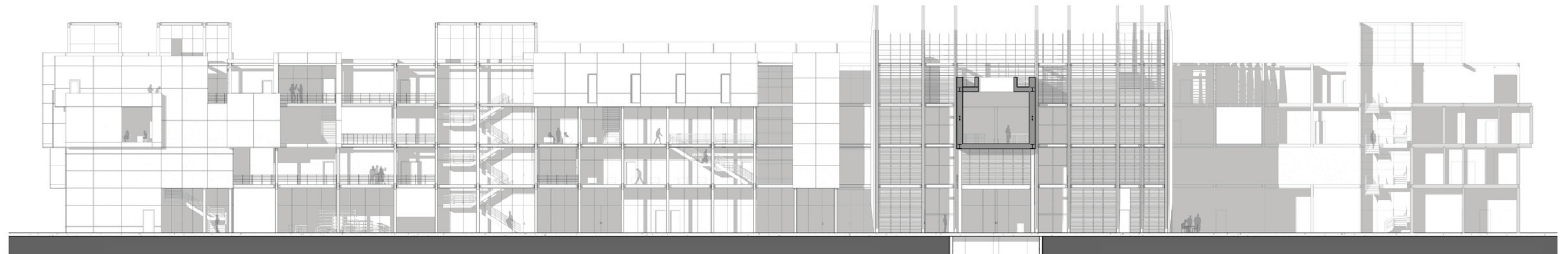

East Elevation

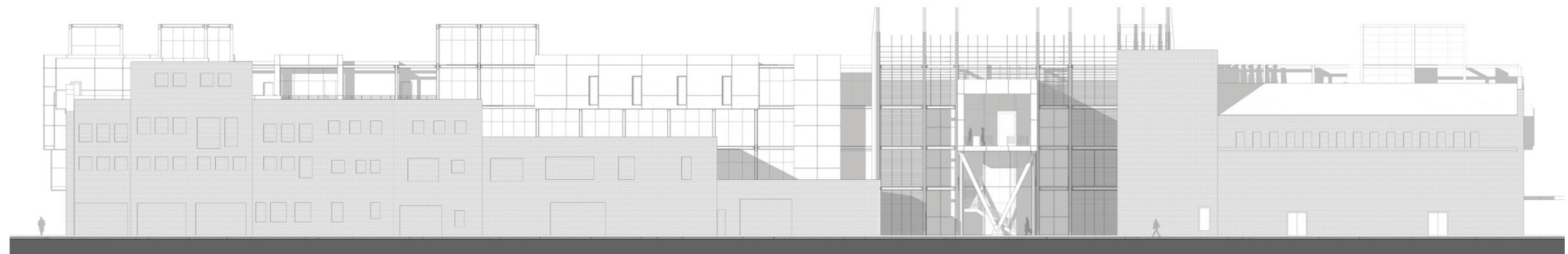

East Elevation (from Wiltburger Street)



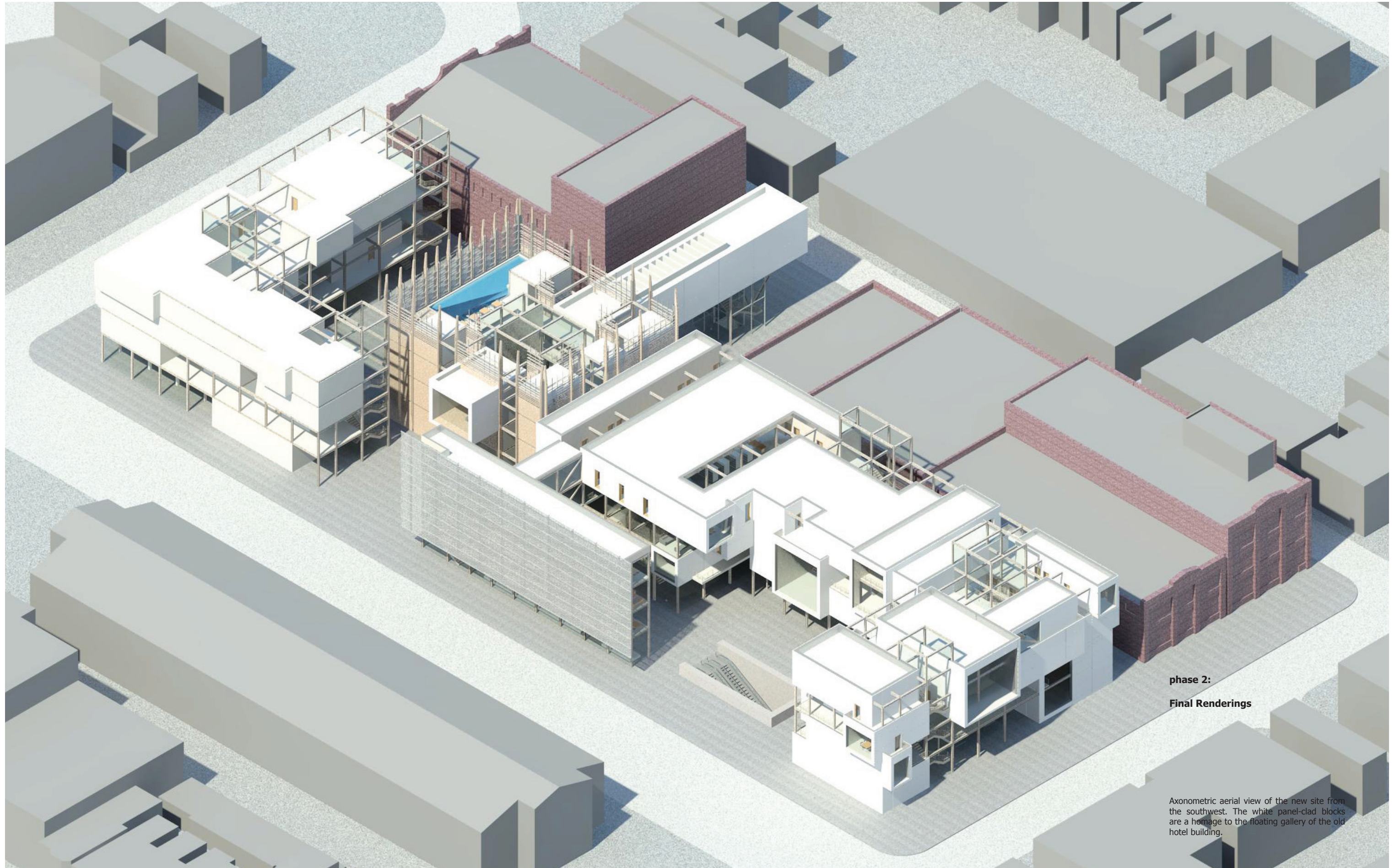

phase 2:
Final Renderings

Axonometric aerial view of the new site from the southwest. The white panel-clad blocks are a homage to the floating gallery of the old hotel building.



View from the intersection of 7th and S Streets. The exposed steel skeleton holds the shifting stacked blocks in place.



View of the classroom buildings from 7th Street. The protruding blocks are a prominent feature of the facades, a strong expression of the new design's concept of shifting volumes.



The old main hotel building, revived as the new school administration building.



Left side, top: A steel mesh facade shades the hallway in the study room building from the afternoon sun. **Bottom:** The auditorium building lobby, a three-storey volume of space, welcomes visitors into the building and guides students and faculty to its upper levels.



Right: From the Shaw/Howard University Metro escalator, a corridor shaped by the study room building on the left and the auditorium building on the right guides visitors toward the school administration building and the student housing building.



Inverted king posts span over the interior of a multi-purpose studio.

conclusion

The purpose of this thesis is to address the problem of waste management in contemporary architectural practices. The project presents a possible solution to the problem of unnecessary construction waste production through incorporating concepts of disassemblable design into future buildings.

Although contemporary construction and real estate development trends are increasingly adopting an eco-friendly attitude toward building design, we must do more. As educated architects, we must design environments with the recognition that nothing is permanent and it must be our goal to ensure that the buildings we design can safely return to the earth at the end of their lives.

During the course of this thesis a paradox arose that questioned the purpose of designing to anticipate change. In the design of the first phase of the project, steel columns and beams were chosen that were larger than required in order to overcompensate for a future program that might require larger loads. However, if the next program did not require larger loads, then the extra material used to create the larger steel members would seem to have been wasted, thus contradicting the purpose of designing for change, which is to reduce material waste. The question then, is whether or not it is worthwhile to design for a future program when that program has not yet been determined.

In the case of this thesis project, the hotel's system of disassembly was utilized in order to accommodate the new community college, which makes the effort beneficial. But even if the hotel's disassemblable parts were not utilized, the effort would still be beneficial because the option to facilitate change would nonetheless exist, perhaps to be used in the building's following life. Thus, designing to anticipate change is advantageous either way. The effort would only be wasted if the entire structure were to be demolished in order to build a completely new building, which, unfortunately, is not an uncommon practice.

The perception of value in today's society has become so distorted that entire buildings can be thrown away just because it has become affordable to do so, regardless of how much waste is produced. The deciding factor for any major decision in any project is cost. If it costs more, the option most beneficial to the earth will be abandoned just to cut down on spending and to produce more profit.

Granted, managing the costs of projects is a reality that designers must face on a day to day basis, and it is undeniable that money is necessary to survive in today's society. However, as important as money may be, it should not be valued more than the planet we live on. Rather, more value should be placed on restoring the parts of the earth that we as a species have corrupted as a result of our greed, and creating future buildings that are safe for our earth. By adopting an attitude that reflects this, environmentally sustainable design would attain a higher position of value in the global market, and would become the chief concern in any project.

We must remember that the monetary system is merely a man-made concept; an intangible figment of our imagination that has become the shaky structure on which we develop our achievements. The earth is real. We breathe real air, drink real water, and tread on real soil. It would be a shame to waste our home in the name of something that does not exist.

Fortunately, since the actions of the global market are determined by our decisions, we can control the market and therefore control the value of any object and entity. We as a species just need to reassess what, in fact, is most valuable to our existence.

bibliography

Ciarimboli, Nicholas, and Guy, Brad. Design for Disassembly in the Built Environment: A Guide to Closed-Loop Design and Building. Life Cycle Building Challenge, 2010. Web. 30 Feb 2010. <<http://www.lifecyclebuilding.org/files/DfDseattle.pdf>>.

Costello, Daniel T., and Webster, Mark D. Designing Structural Systems for Deconstruction: How to Extend a New Building's Useful Life and Prevent it From Going to Waste When the End Finally Comes. Life Cycle Building Challenge, 2010. Web. 30 Feb 2010. <<http://www.lifecyclebuilding.org/files/DfDseattle.pdf>>.

Durability Implications. Canadian Architect. N.p., n.d. Web. 30 Feb 2010. <http://www.canadianarchitect.com/asf/enclosure_durability/durability_implications/durability_implications.htm>.

Morgan, Chris, and Stevenson, Fionn. Design for Deconstruction: SEDA Guidelines for Scotland: No.1. Enclosure Durability - Durability Implications. Scottish Ecological Design Association. Scottish Executive, 2010. Web. 30 Feb 2010. <<http://www.seda.uk.net/dfd/dfd.pdf>>.

Viollet-Le-Duc, Eugene-Emmanuel. The Architectural Theory of Viollet-Le-Duc: Readings and Commentaries. MIT Press, 1990.

Williams, Paul Kelsey, et al. Historic Survey of Shaw East Washington, DC. Washington, DC: Shaw Main Streets, 2005. Web. 27 Feb 2010. <<http://www.shawmainstreets.com/shaweastsurvey.pdf>>.

montage image sources

Euromax/Kow | ArchDaily. Web. 3 Feb 2010. <<http://www.archdaily.com/45817/euromax-kow/>>.

Middle School Morières Les Avignon / N+B Architectes | ArchDaily. Web. 3 Feb 2010. <<http://www.archdaily.com/46597/middle-school-morie%CC%80res-les-avignon-nb-architectes/>>.

Townhouse / Elding Oscarson | ArchDaily. Web. 3 Feb 2010. <<http://www.archdaily.com/46808/townhouse-elding-oscarson/>>.

Virgin Active / BAM Architects | ArchDaily. Web. 3 Feb 2010. <<http://www.archdaily.com/47193/virgin-active-bam-architects/>>.

Sumaré House / Isay Weinfeld | ArchDaily. Web. 3 Feb 2010. <<http://www.archdaily.com/44117/sumare-house-isay-weinfeld/>>.

Ross Street House / RWH Design | ArchDaily. Web. 3 Feb 2010. <<http://www.archdaily.com/47353/ross-street-house-rwh-design/>>.

Memory Museum / Estudio America | ArchDaily. Web. 3 Feb 2010. <<http://www.archdaily.com/47720/memory-museum-estudio-america/>>.

Apocalyptic_Sky_by_MattTheSamurai.jpg picture by Temp Stock - Photobucket Groups. Web. 3 Feb 2010. <http://gs133.photobucket.com/groups/q46/Q4AXV9O5EG/?action=view¤t=Apocalyptic_Sky_by_MattTheSamurai.jpg&mediafilter=images>.

The slums of Delhi. India, Katrina, and the Bailout: How Poor People Everywhere Are Being Neglected << Allison Kilkenny: Unreported. Web. 3 Feb 2010. <<http://allisonkilkenny.wordpress.com/2008/12/03/india-katrina-and-the-bailout-how-poor-people-everywhere-are-being-neglected/>>.

August 2004. Roseburg Landfill Statistics. Web. 3 Feb 2010. <http://www.heartwoodresources.org/roseburg_landfill_statistics.htm>.

Stationary. Web. 3 Feb 2010. <<http://blog.lib.umn.edu/scha1028/architecture/>>.

"Sea gull, Byxbee Park 1-1-07, Canon D30 ." Palo Alto Baylands. Web. 3 Feb 2010. <<http://www.stanford.edu/~siegelr/baylands.html>>.

image sources

Figure 1 Washington, DC. Map. Google Maps. Google, 28 February 2010.

Figure 2 Washington, DC. Map. Google Maps. Google, 28 February 2010.

Figure 3 Washington, DC. Map. Google Maps. Google, 28 February 2010.

Figure 4 Manhattan Automobile Showroom. Williams, Paul Kelsey, et al. Historic Survey of Shaw East Washington, DC. Washington, DC: Shaw Main Streets, 2005. Web. 27 Feb 2010. <<http://www.shawmainstreets.com/shaweastsurvey.pdf>>.

Figure 5 Camp Campbell. Williams, Paul Kelsey, et al. Historic Survey of Shaw East Washington, DC. Washington, DC: Shaw Main Streets, 2005. Web. 27 Feb 2010. <<http://www.shawmainstreets.com/shaweastsurvey.pdf>>.

Figure 6 Iron Strut Detail. Viollet-Le-Duc, Eugene-Emmanuel. The Architectural Theory of Viollet-Le-Duc: Readings and Commentaries. MIT Press, 1990, p. 244.

Figure 7 Great Hall. Viollet-Le-Duc, Eugene-Emmanuel. The Architectural Theory of Viollet-Le-Duc: Readings and Commentaries. MIT Press, 1990, p. 243.

Figure 8 Diagram of bamboo structure. Viollet-Le-Duc, Eugene-Emmanuel. The Architectural Theory of Viollet-Le-Duc: Readings and Commentaries. MIT Press, 1990, p. 191.

Figure 9 Details of bamboo framing. Viollet-Le-Duc, Eugene-Emmanuel. The Architectural Theory of Viollet-Le-Duc: Readings and Commentaries. MIT Press, 1990, p. 191.

Figure 10 Interior of a Chinese House. Viollet-Le-Duc, Eugene-Emmanuel. The Architectural Theory of Viollet-Le-Duc: Readings and Commentaries. MIT Press, 1990, p. 190.

Figure 11 Cellophane House exterior. KT [Cellophane House] Web. 21 Mar 2010. <http://kierantimberlake.com/pl_sustainability/cellophane_house_1.html>.

Figure 12 Cellophane House under construction. Home Delivery: Wrapping It Up With The Cellophane House. Web. 21 Mar 2010. <<http://www.treehugger.com/files/2008/07/wrapping-up-with-the-cellophane-house.php>>.

Figure 13 Cellophane House module diagram. KT [Cellophane House] Web. 21 Mar 2010. <http://kierantimberlake.com/pl_sustainability/cellophane_house_1.html>.

Figure 14 Exterior close-up view. Nakagin Capsule Tower: Architecture of the Future. Web. 6 Mar 2010. <<http://pingmag.jp/2008/12/22/nakagin/>>.

Figure 15 Exterior view. Nakagin Capsule Tower: Architecture of the Future. Web. 6 Mar 2010. <<http://pingmag.jp/2008/12/22/nakagin/>>.

Figure 16 Capsule interior view. Nakagin Capsule Tower: Architecture of the Future. Web. 6 Mar 2010. <<http://pingmag.jp/2008/12/22/nakagin/>>.

Figure 17 Exterior view. R128. Web. 10 Mar 2010. <<http://www.wernersobek.de/index.php?page=251&modaction=detail&modid=30>>.

Figure 18 Stairs. R128. Web. 10 Mar 2010. <<http://www.wernersobek.de/index.php?page=251&modaction=detail&modid=30>>.

Figure 19 Interior view. R128. Web. 10 Mar 2010. <<http://www.wernersobek.de/index.php?page=251&modaction=detail&modid=30>>.

Unless otherwise noted, all images were created by the author.

Use of all cited material is strictly for educational purposes in compliance with the Fair Use requirements.