

Precision Farming Tools: Variable-Rate Application

Robert “Bobby” Grisso, Extension Engineer, Biological Systems Engineering, Virginia Tech

Mark Alley, Retired Extension Agronomist and Professor, Crop & Soil Environmental Sciences, Virginia Tech

Wade Thomason, Assistant Professor and Extension Grain Crops Specialist, Crop & Soil Environmental Sciences, Virginia Tech

David Holshouser, Associate Professor and Extension Agronomist, Crop & Soil Environmental Sciences, Virginia Tech

Gary T. Roberson, Associate Professor and Extension Specialist, North Carolina State University

Introduction

There are a number of questions that must be answered before establishing a site-specific crop management (SSCM) program. Many of these questions are economic, some are agronomic and environmental, and others are technology-related. This publication is intended to discuss variable-rate devices that are available, while providing an understanding of which technologies might best fit a cropping system and production management strategy.

Most farmers have practiced a form of variable-rate application (VRA) with a conventional sprayer. A conventional sprayer applies a chemical that is tank-mixed with a carrier (usually water) using spray nozzles and a pressure-regulating valve to provide a desired volumetric application of spray mix at a certain vehicle speed.

Any change in the boom pressure or vehicle speed from that of the calibration results in an application rate different from the planned rate. Applicators have used this to their advantage at times. For example, when observing an area of heavy weed infestation, the applicator can manually increase the pressure or reduce the speed to apply a higher (but somewhat unknown) rate of herbicide.

Variable-Rate Application Methods

One important technology-related question is: What methods of variable-rate application of fertilizer, lime, weed control, and seed are available? There are a variety of VRA technologies available that can be used with or without a GPS system. The two basic technologies for VRA are: **map-based** and **sensor-based**.

Map-based VRA adjusts the application rate based on an electronic map, also called a prescription map. Using the field position from a GPS receiver and a prescription map of desired rate, the concentration of input is changed as the applicator moves through the field.

Sensor-based VRA requires no map or positioning system. Sensors on the applicator measure soil properties or crop characteristics “on the go.” Based on this continuous stream of information, a control system calculates the input needs of the soil or plants and transfers the information to a controller, which delivers the input to the location measured by the sensor. Because map-based and sensor-based VRA have unique benefits and limitations, some SSCM systems have been developed to take advantage of the benefits of both methods.

Map-Based VRA

The map-based method uses maps of previously measured items and can be implemented using a number of different strategies. Crop producers and consultants have crafted strategies for varying inputs based on (1) soil type, (2) soil color and texture, (3) topography (high ground, low ground), (4) crop yield, (5) field scouting data, (5) remotely sensed images, and (6) numerous other information sources that can be crop- and location-specific.

Some strategies are based on a single information source while others involve a combination of sources. Regardless of the actual strategy, the user is ultimately in control of the application rate. These systems must have the ability to determine machine location within the field and relate the position to a desired application rate by “reading” the prescription map.

www.ext.vt.edu

For example, to develop a prescription map for nutrient VRA in a particular field, the map-based method could include the following steps:

- Perform systematic soil sampling (and lab analysis) for the field.
- Generate site-specific maps of the soil nutrient properties of interest.
- Use an algorithm to develop a site-specific nutrient prescription map.
- Use the prescription map to control a fertilizer variable-rate applicator.

A positioning system is used during the sampling and application steps to record location of the sampling points in the field and to apply the prescribed nutrient rates in the appropriate areas of the field.

Sensor-Based VRA

The sensor-based method provides the capability to vary the application rate of inputs with no prior mapping or data collection involved. Real-time sensors measure the desired properties — usually soil properties or crop characteristics — while on the go. Measurements made by such a system are then processed and used immediately to control a variable-rate applicator.

The sensor method doesn't necessarily require the use of a positioning system, nor does it require extensive data analysis prior to making variable-rate applications. However, if the sensor data are recorded and geo-referenced, the information can be used in future site-specific crop management exercises for creating a prescription map for other and future operations, as well as to provide an "as applied" application record for the grower.

VRA FAQs

What is VRA? VRA is an abbreviation for variable-rate application, which is a method of applying varying rates of inputs in appropriate zones throughout a field. The goals of VRA are to maximize profit to its fullest potential, create efficiencies in input application, and ensure sustainability and environmental safety.

What are VRA management zones? VRA management zones illustrate the natural variability of a field and are used to manage the VRA of inputs across the field. On average, most fields have five different zones, but this varies with the field (see *Interpreting Yield Maps: I Gotta Yield Map — Now What?* VCE publication 442-509).

What is a prescription map? A prescription map is an electronic data file containing specific information about input rates to be applied in every zone of a field.

What is remote sensing? Remote sensing is the science and art of acquiring information about the earth's surface without actually coming in contact with it. This is done by recording energy, which is either reflected or emitted from the earth's surface. The information recorded is then processed and analyzed, and the information is used to develop a prescription map that can be used in a variable-rate application.

How does VRA increase economic potential? VRA increases your economic return by strategically optimizing inputs in each management zone. VRA allows you to focus inputs on management zones that provide the highest return, while reducing inputs in lower productivity zones or where previous management has resulted in a situation for reduced input need.

Seeding VRA

Planters and drills can be made into VRA seeders by adjusting the speed of the seed-metering drive. This will effectively change the plant population. VRA seeding is accomplished by separating or disconnecting the planter's seed-meter systems from the ground drive wheel. By attaching a motor or gear box (to change speed of the ground wheel input), the seeding rate can be varied on the go. Most of these devices will be matched with a prescription map and can have two or more rates. A two-rate scenario may be a system that reduces the seeding rates outside of the reach of a center-pivot irrigation system, while multiple rates may be needed to adjust for soil types (water-holding capacity) and organic matter.

An example of a commercial system is available from Trimble Inc. (www.trimble.com/agriculture/Variable-Rate-Application-Solution.aspx?dtID=overview); it includes a hydraulic drive unit, processor, and groundspeed sensor. A hydraulic motor (powered by tractor hydraulics) is attached to an electric stepper motor (figure 1) to control the speed delivered to the seed-meter shaft (figure 2).

A controller receives a groundspeed signal and coordinates the speed with planter width and seeding rate to send a signal to the hydraulic drive. On some planters/drills, the seeding rates are matched with the application rates of fertilizer, herbicides, or insecticide units because they are driven by the same meter shaft.



Figure 1. Hydraulic motor to control seed meter (PAR-2 Variable Rate Drive; www.trimble.com/agriculture/Variable-Rate-Application-Solution.aspx?dtID=overview).

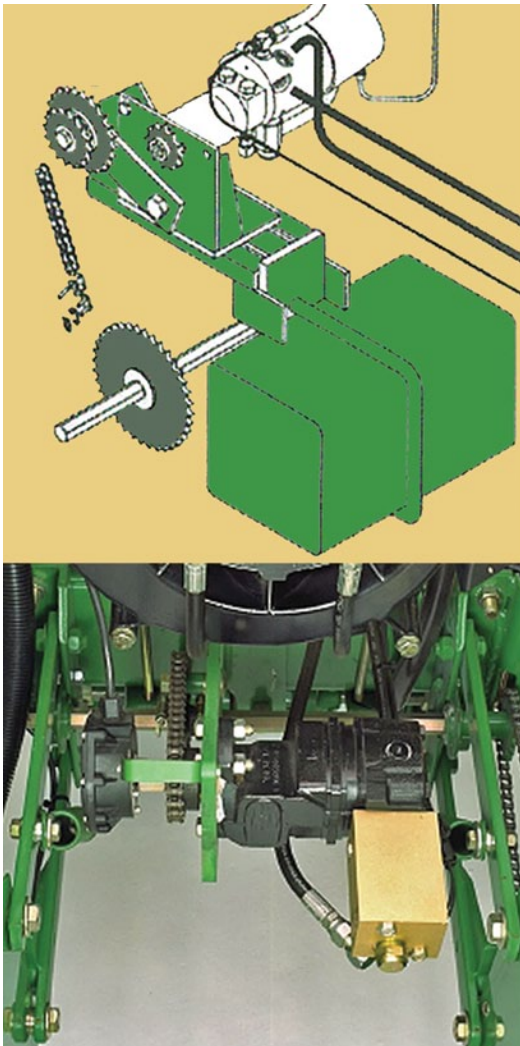

Figure 2. Hydraulic motor attached to the seed-meter shaft (Trimble Variable Rate Controllers; www.trimble.com/agriculture/Variable-Rate-Application-Solution.aspx?dtID=overview).

There is development of using on-the-go sensors to VRA seeding (figure 3). There are soil organic matter (SOM) sensors that detect different levels of organic matter and adjust the plant population rate accordingly. Soil moisture meters that may be used for depth adjustment and for changing seeding rates are available.

Weed Control VRA

For map-based weed control VRA systems, some form of “task computer” is required to provide a signal indicating the target rate for the current location. Second, a system for physically changing the application rate to match the current prescribed rate is required.

There are a number of different types of control systems on the market today that are adaptable to VRA. Three categories will be discussed:

1. Flow-based control of a tank mix.
2. Chemical-injection-based control, with the subset, chemical-injection control with carrier.
3. Modulated spraying-nozzle control system.

Incidentally, all of these systems evolved out of the desire to automatically match application rates to variations in groundspeed.

These systems eliminate much of the error in application that could occur if groundspeeds change from the calibrated setup. With the application rate managed by an electronic system, the ability to apply variable rates is a logical next step. This requires that the prescribed application rate, or “set point,” be changeable according to the rate prescribed for that location.

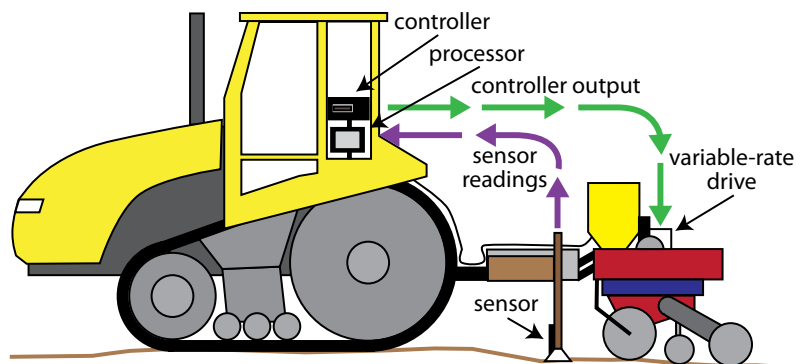

Figure 3. “On-the-go” sensor (texture, electrical conductivity (EC), or soil organic matter (SOM)) measures soil characteristics before planting and adjusting the seeding rate (plant population).

Flow-Based Control Systems

The flow-based control of a tank mix is the simplest of the three types discussed here. These systems combine a flow meter, a groundspeed sensor, and a controllable valve (servo valve) with an electronic controller to apply the desired rate of the tank mix (figure 4). A microprocessor in the console uses information regarding sprayer width and prescribed gallons per acre to calculate the appropriate flow rate (gallons per minute) for the current groundspeed. The servo valve is then opened or closed until the flow-meter measurement matches the calculated flow rate. If a communication link can be established between this controller and a “map system,” a VRA can be made. These systems have the advantage of being reasonably simple. They are also able to make rate changes across the boom as quickly as the control system can respond to a new rate command, which is generally quite fast (three to five seconds).

As with any technology, flow-based controllers have limitations. The flow sensor and servo valve control the flow of tank mix by allowing variable pressure rates to be delivered to the spray nozzles. This can result in large changes in spray droplet size and potential problems with drift.

Some systems will warn you when the pressure is outside the optimum operating range for the nozzles. The operator can adjust vehicle speed to return the pressure to an acceptable range. This is the most widely used system. Its standard operating procedures specify that the operator must mix the chemical in the spray tank with the carrier and will generally have to deal with some leftover tank mix. However, this is a relatively simple system that should meet most needs while giving operators the capability of a single herbicide VRA.

Chemical Direct-Injection Systems

An alternative approach to chemical application and control uses direct injection of the chemical into a stream of water. These systems (figure 5) utilize the controller and a chemical pump to manage the rate of chemical injection rather than the flow rate of a tank mix. The flow rate of the carrier (water) is usually constant and the injection rate is varied to accommodate changes in groundspeed or changes in prescribed rate. Again, if the controller has been designed or modified to accept an external command (from a GPS signal and prescription map), the system can be used for VRA.

Chemical injection eliminates leftover tank mix and reduces chemical exposure during tank mixing. An additional advantage of this system is that the constant flow of carrier can be adjusted to operate the boom nozzles to provide the optimum desirable size and distribution of spray droplets. The principal disadvantage for variable-rate control is the long transport delay between the chemical-injection pump and the discharge nozzles at the ends of the boom. The volume within the spray plumbing (hoses and attachments) must be applied before the new rate reaches the nozzles. This can cause delays in the rate change and “Christmas tree” patterns of application as the new concentration of chemical works its way out through the boom.

For example, a simulation of a farmer-owned broadcast sprayer (60-foot boom divided into five sections) indicated that nearly 100 feet of forward travel would occur before a newly prescribed rate would find its way to the end nozzles of that sprayer. However, a properly designed plumbing system and properly matched nozzles can shorten the reaction time. Some control systems will look forward (knowing location and speed) and make the required adjustments.

These limitations have led to systems that use both carrier and injection control. All manufacturers would recommend VRA be used in conjunction with carrier control as described below.

Direct Chemical Injection With Carrier Control

Chemical injection with carrier control requires the control system change both the chemical-injection rate and the water-carrier rate to respond to speed or application-rate changes. One control loop manages the injection pump while a second controller operates a servo valve to provide a matching flow of carrier. A perfect system of this type would deliver a mix of constant concentration as if it were coming from a pre-mixed tank.

The system can have many of the advantages of both of the earlier systems. Direct injection of chemicals means that there is no leftover mix to worry about, and the operator is not exposed to chemicals in the process of tank mixing. Changeover from one rate to another occurs as quickly as both chemical and carrier controllers can make the change, which is usually very fast.

Disadvantages include a more complex system with higher initial cost and the problem of delivering varying amounts of liquid through the spray nozzles as rates

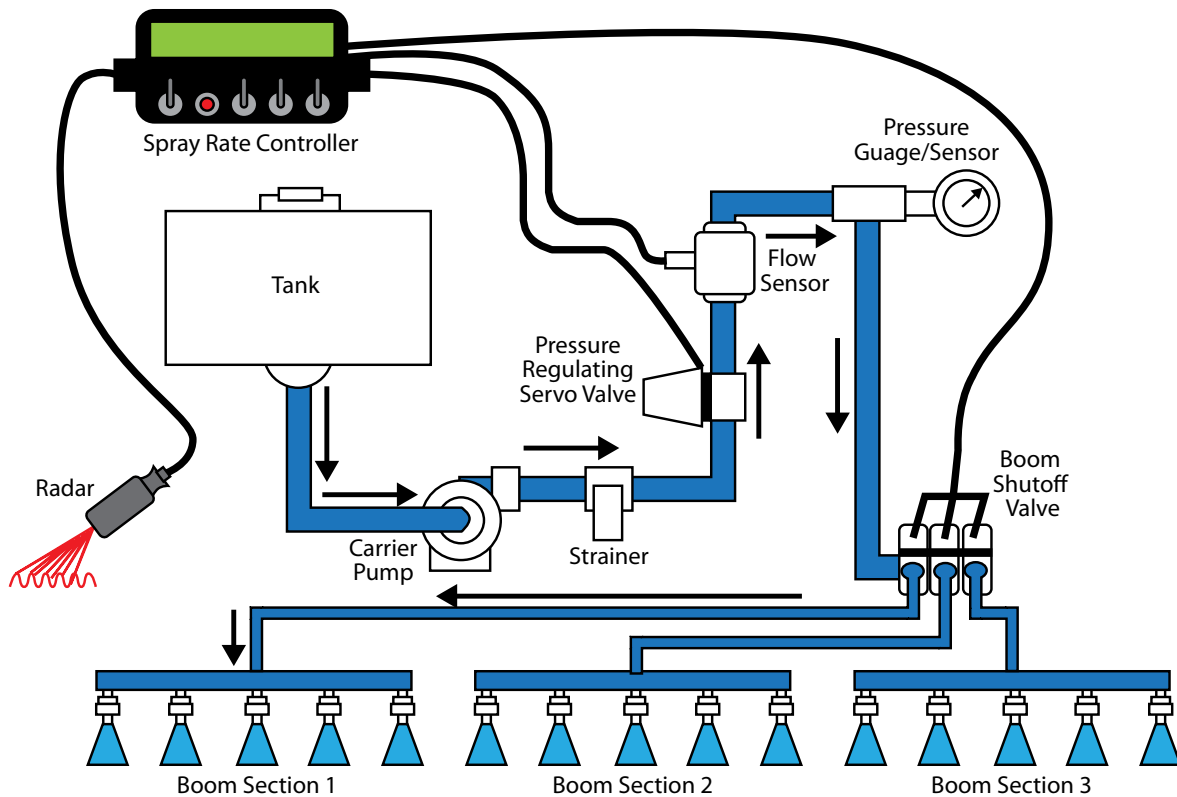

Figure 4. VRA spraying system that is a flow-based control system of application rate.

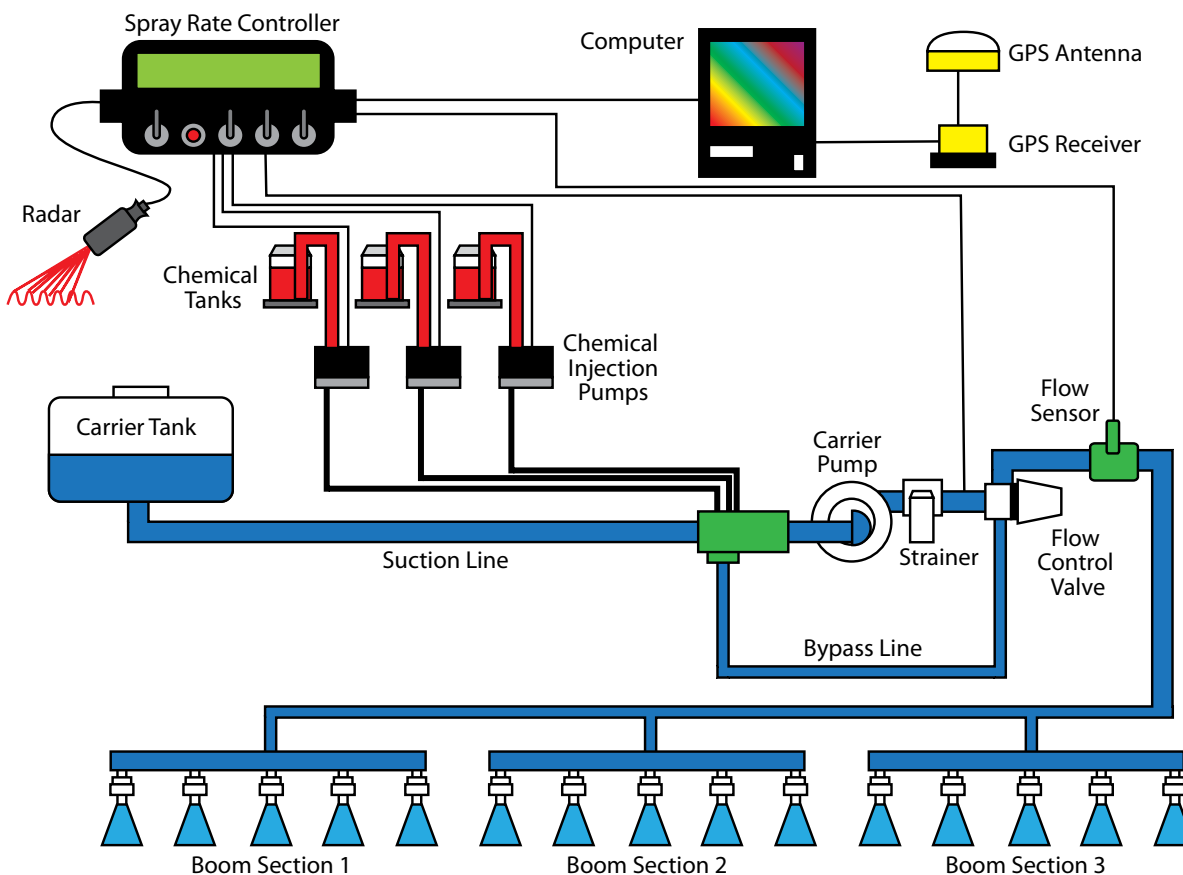

Figure 5. VRA spraying system that incorporates chemical-injection technology. In this case, three injection pumps and holding tanks are available for three different chemicals to be applied at different rates.

change, with the resulting changes in droplet and spray characteristics. If you do a lot of spraying and wish to avoid the hazards of tank mixing, these systems will give you a great deal of control over your spraying operations and offer the capability of VRA of herbicides from a prescription map.

Modulated Spraying-Nozzle Control Systems

Modulated spraying-nozzle control (MSNC) systems permit VRA with spray drift control under a wide range of operating conditions. MSNC controls the timing and duration of discharge from nozzles. High-speed valves are used to regulate the amount of time that spray is delivered from conventional nozzles. The systems offer the ability to change flow rate and droplet size distribution on the go. A brief description of the system follows.

MSNC-equipped sprayers use conventional sprayer nozzle assemblies that work in conjunction with direct-acting, in-line solenoid valves. Figure 6 is a schematic of a spraying system that incorporates modulated spraying-nozzle control. The system operates under the direction of a microprocessor and an application controller that responds to signals from flow and pressure sensors.

The basic concept behind MSNC spraying is to operate each nozzle at full design pressure and flow during periods when a flow control valve is open. The key is to vary the amount of time that the valve stays open to produce variation in the flow rate (thus, application rate) without changing droplet size distribution or spray pattern. A fast-acting, electrical, solenoid-controlled nozzle assembly (figure 7) is mounted directly to a conventional nozzle assembly.

MSNC systems are equipped with solenoids that operate at a frequency of 10 Hz. This means that solenoid position can be cycled between open and closed 10 times per second, as directed by a controller that responds to input from a computer and a set of sensors. A cycle of events (valve open/spray/valve close) takes place in one-tenth of a second.

In order for MSNC systems to operate most effectively, valve response must be quite rapid. An electrical signal to each valve is used to produce one of two flow conditions: full flow (completely open valve) or zero flow (completely closed valve). The solenoid-operated valves take only about 4 milliseconds (ms) or 0.004 second to respond to an electrical signal.

Changing valve position from open to closed and back (or vice versa) would take 8 ms during any 0.1-second cycle. In actual practice, this translates into a minimum

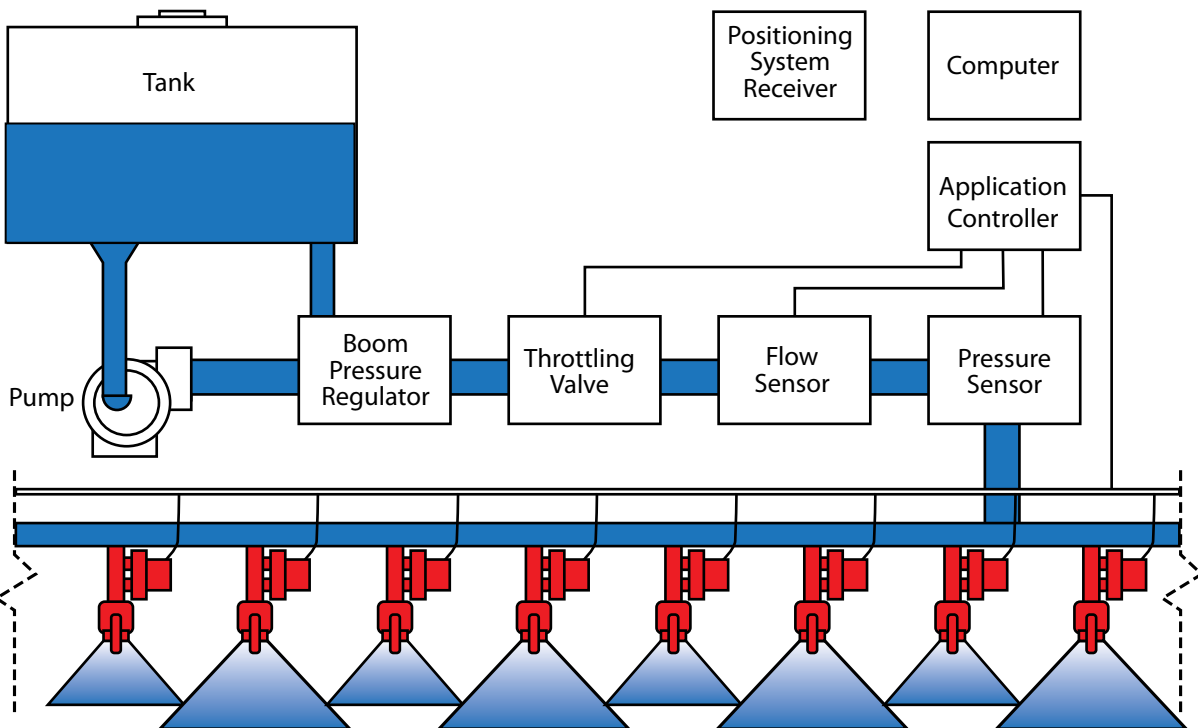

Figure 6. VRA spraying system using modulated spraying-nozzle control (MSNC) technology. The controller can control individual nozzles or a single signal for the entire boom.

duty cycle (amount of time the valve is open for flow) of about 10 percent and a maximum duty cycle of about 90 percent if the control system is changing valve position during each 0.1-second time period. The MSNC system can also be operated at a full-open (100 percent duty cycle) setting as well.

Because flow rate from each nozzle is governed by the amount of time (duty cycle) each flow-control valve stays open, the percentage of full, rated, nozzle flow would be equal to the duty cycle expressed as a percentage. This results in a range of flow rates from each nozzle of approximately 9-to-1, although the MSNC systems have been advertised with a more conservative rating of flow-control range at 8-to-1.

For example, let's say that a standard nozzle has a rated capacity of 0.8 gpm at a pressure of 40 psi. The MSNC system is very effective at reducing nozzle flow rates while maintaining droplet size distribution and spray-pattern characteristics. Therefore, standard procedure/strategy is to install nozzles that will meet the maximum flow demand in a particular spraying situation.

The MSNC system is then used to reduce rates as needed. A benefit of using larger nozzles is the reduced likelihood of plugging.

In addition to controlling nozzle flow rates at a given system pressure, the MSNC system can be operated at reduced pressures to increase droplet size and reduce drift potential in locations and under atmospheric conditions in which drift would likely cause damage. Application rates could be maintained, even as system pressure is lowered, by increasing the amount of time the nozzle remains open during a minute.

Opening and closing nozzles as a sprayer travels through the field might appear to be a risky proposition. If a nozzle is held closed, even for an instant, no liquid will be discharged. Surely there will be areas of a field missed during normal operation of the sprayer! This is addressed by using a 1/20-second (1/2-cycle) "phase shift" of adjacent nozzles. When one nozzle is off, the nozzles adjacent to it are on. To increase spray-pattern overlap and minimize the effect of the "pulses and pauses" produced at the nozzles, these sprayers are

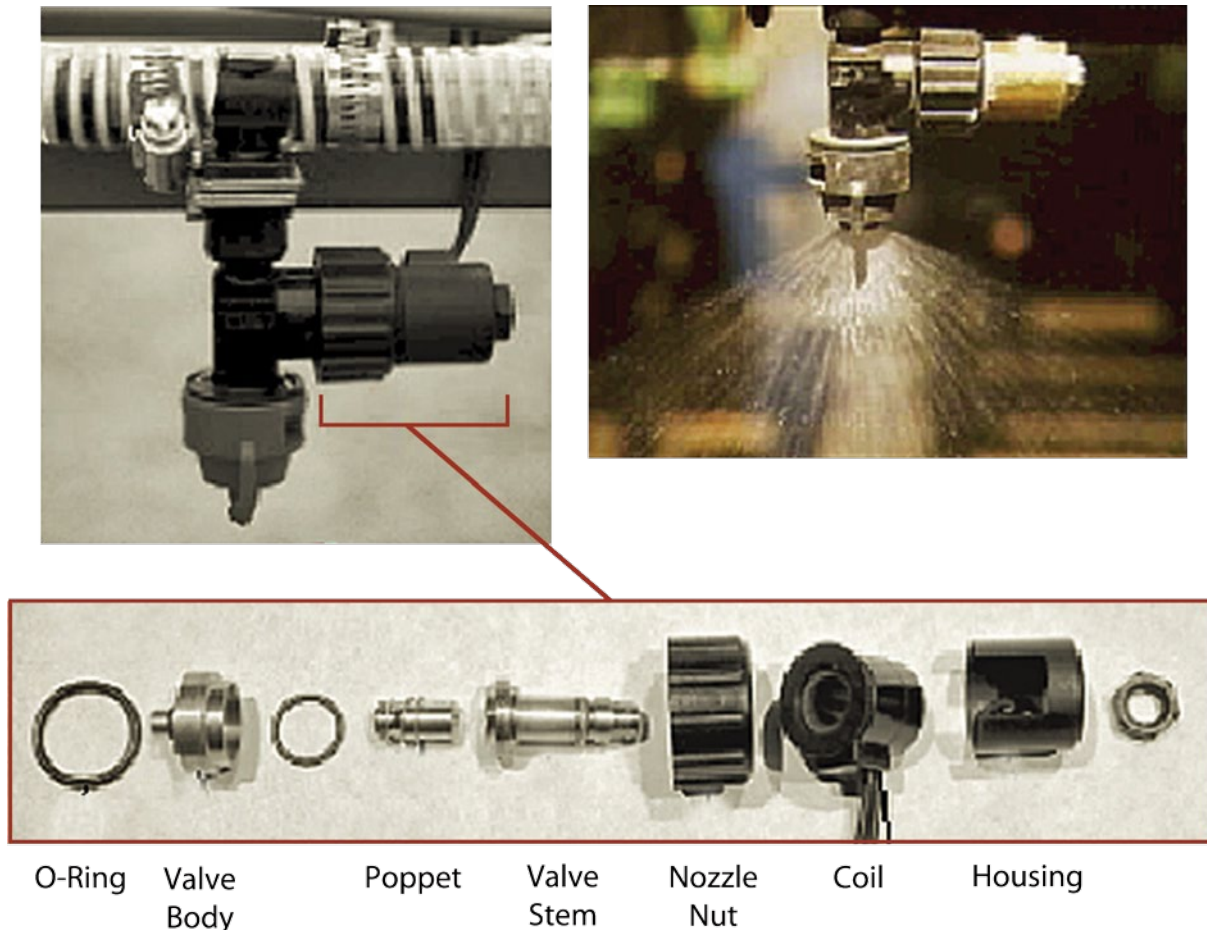

Figure 7. Fast-acting, electrical, solenoid-controlled nozzle assembly.

equipped with wide spray-angle nozzles (110-degree angle versus the more-common 80-degree angle).

The potential benefits of using a chemical-application system that permits the tailoring of both application rate and droplet-size distribution throughout a field include the ability to:

- Produce a broader range in flow rates with much more consistent spray characteristics than conventional sprayers.
- Vary nozzle flow rates and/or travel speeds over a wide range without affecting spray pattern or droplet-size distribution.
- Vary droplet-size distribution without changing application rate to minimize drift potential near sensitive areas or to increase spray coverage needed for some contact-type products.

MSNC technology can also be used to apply VRA nutrients. While drift control is not a major issue in fertilizer application, the MSNC provides yet another option for applicators wishing to take advantage of site-specific crop management methods.

New and Developing VRA Systems

A few control systems have been discussed here. However, this is an area of rapid change, and new models with advanced features debut regularly. Searching the Web using the manufacturer's name as a keyword can be a useful means of locating product descriptions and specifications. However, Web-based resources change rapidly and a search will undoubtedly turn up new information that may help in selecting an appropriate system for individual farming practices.

Other Useful Devices

There are areas of the field that should not have chemicals applied. For example, a grass waterway is a best management practice (BMP) to reduce erosion impacts from a field, but if a nonselective herbicide is sprayed to the area while passing over the section, much damage to the BMP will result. By mapping these areas of the field, a boom control can automatically turn the boom (or sections of the boom) on and off to prevent application to selected areas. The controller can also automatically turn the boom section off if the boom section is in a previously applied area (figure 8), eliminating overlaps. It also eliminates skips by turning boom sections back on after leaving a previously applied area.

If the sprayer goes over an area that has already received an application (figure 8), the controller detects the overlap and shuts off individual sections or nozzles of the implement to prevent the unnecessary usage of additional chemicals. When spraying odd-shaped fields, grass waterways, or obstructions in a field, this boom control can have a tremendous benefit.

Because an automated boom section-control device requires a capital investment, applicators should weigh the cost of the machine against their potential savings on inputs before purchasing the equipment. However, one Virginia farmer using the technology indicated a 15 percent savings in inputs (crop protection chemicals and liquid fertilizers) due to automatic boom control.

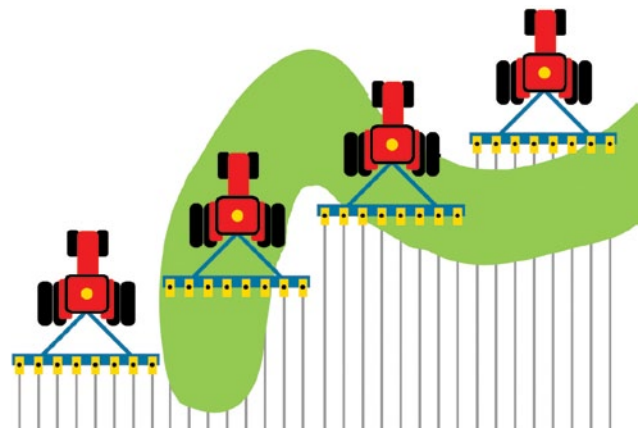

Figure 8. Electronic boom control to eliminate overlaps available for both spraying and planting.

Sensor-Based Devices

Soil organic matter sensors can be used with VRA pre-plant herbicides because the amount of soil organic matter influences the effectiveness of some herbicides (often mentioned on the label). Such a sensor (figure 9) can be used to automatically adjust herbicide rates without prescription maps or other inputs. In this application, the sensor is pulled or pushed through the soil by the herbicide applicator.

Due to patchiness of weed infestations, uniformly treating entire fields can result in unsatisfactory weed control or unnecessary use of herbicides. Remote-sensing may be a technique that will improve weed scouting and result in better management decisions. Our eyes act as remote sensors. We can easily identify weed-free and weedy areas in a soybean field and distinguish between different weed species based on leaf shapes and sizes. When a remote-sensing instrument collects reflectance at the field scale, reflectance values from

individual features are averaged over the entire pixel area within the sensor. Using reflectance data of bare ground contrasted with green weeds growing between crop rows, some sprayers are equipped to switch the application device on and off.

One example of a commercial unit is a WeedSeeker (figure 10), which has a reflectance sensor that identifies chlorophyll. The microprocessor interprets that data and when a threshold signal (when weeds are present) is crossed, a controller turns on the spray nozzle. The WeedSeeker system is built around close-proximity optical sensors using near-infrared (NIR), light-reflectance measurements to distinguish between green vegetation, bare soil, and crop residue.

Each sensor unit consists of a light source and an optical sensor (figure 11). The sensors are mounted on a bar or spray boom ahead of the spray nozzle and aimed at the ground. When a chlorophyll (green) reflectance signal exceeds a threshold (set during calibration by the operator), a signal is sent from a controller to a solenoid-operated valve to release herbicide.

The system is designed to turn on slightly before a weed is reached and stay on until slightly after a weed is passed. It can operate at travel speeds of 3 to 10 mph. In areas where weed infestation levels are variable, the unit can significantly reduce chemical application amounts (compared to uniform, continuous applications). Because the WeedSeeker is not designed to distinguish between plant types (desirable crops versus unwanted weeds), its agricultural use is focused on between-the-row applications in standing crops or on-spot treatment of fallow ground.

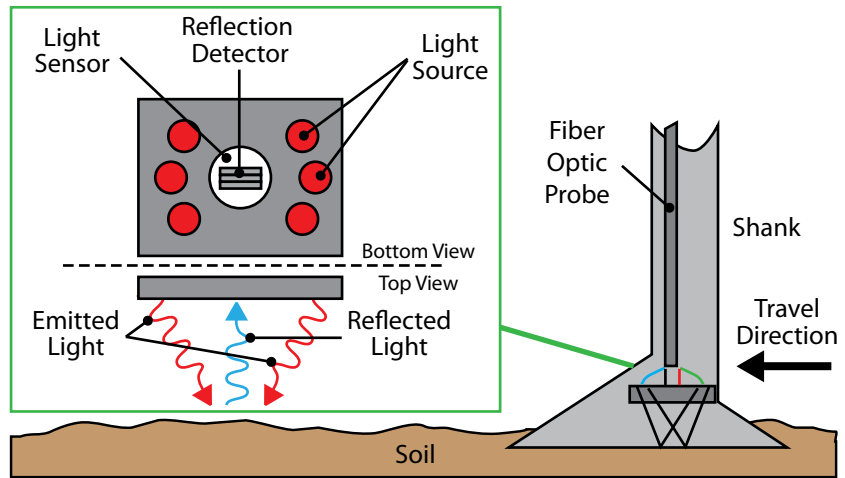

Figure 9. Cross-section schematic of a subsurface, soil-reflectance optical sensor to measure soil organic matter (Adamchuk and Jasa 2002).



Figure 10. Sensor-based WeedSeeker for herbicide control www.ntechindustries.com/rowcrop.html.

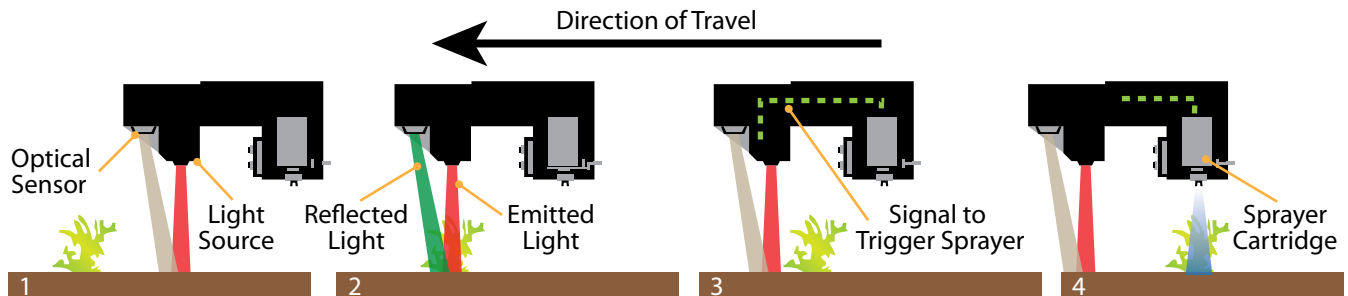

Figure 11. The optical sensor control of the spray nozzle (WeedSeeker; www.ntechindustries.com/rowcrop.html).

Another device that is a sensor-based control is the boom-height control (figure 12). Even though this is not a VRA device, it does improve proper coverage from a spray boom, which will eliminate streaks and improper overlaps. The ultrasonic sensors measure (40 times per second) the distance to the ground. This information allows the control system to make responsive height adjustments so that sprayer booms automatically follow the contours of the land. The system has shown reliable control with average speeds more than 18 mph in all kinds of uneven terrain.



Figure 12. Spray-boom control to eliminate streaks and improper overlaps (www.norac.ca/products.php).

Lime VRA

According to economists, one of the most-profitable SSCM strategies for soil pH management is VRA lime application. Yield response to soil pH is unique in that yield may decrease both with pH levels that are too low and with pH levels that are too high. Consequently, there is a yield penalty for either underapplication or overapplication of lime; thus, improved accuracy means higher yields. Similarly, that added penalty (for excessive inputs) might come artificially to other crops and inputs in the form of environmental regulations and taxes, largely increasing the potential economic gains to precision farming. Across the United States, numerous acres are sampled at scales typically ranging from 2.5 to 4.0 acres.

Applicators using VRA for dry chemicals (lime amendments and nutrients (nitrogen, phosphorus, and potassium, NPK)) include both spinner spreaders (figure 13) and pneumatic applicators (figure 14). Spinner spreaders with a single hopper body vary only one product at a time. A conveyor belt or chain transfers material from



Figure 13. Spreaders for applying dry chemicals (lime, nutrients), and the hop conveyor can be driven for VRA.

a hopper and feeds it onto the spinning disks. The application rate is controlled by adjusting the gate opening and/or changing the speed of the conveyor. The drive mechanism used to control the conveyor is similar to the drive discussed for VRA seeding.

VRA pneumatic applicators convey the material uniformly by an air stream through a piped boom. These applicators have centrally located bins, or hoppers, and distribute dry material suspended in an air stream. Single or multiple products can be blended and metered on the go with metering devices on each bin.



Figure 14. Pneumatic spreaders for applying dry chemicals (lime, nutrients), and the hop conveyor can be driven for VRA.

The pH prescription map can be developed using grid sampling or an on-the-go sensor. The on-the-go sensor is a device that scoops a small amount of soil, presses it against an electrode, waits a moment for the electrode to stabilize, records the reading, and then rinses the mechanism to prepare for the next sample. The apparatus is a separate operation and is mounted on a toolbar pulled by a pickup truck, large ATV, or small tractor. The commercial Veris Mobile Sensor Platform is marketed as having the “pH Manager” option (figure 15), which includes the sensors to measure soil electrical conductivity (EC). (For more about EC devices and their application to SSCM, see *Precision Farming Tools: Soil Electrical Conductivity*, VCE publication 442-508.)

Fertilizer VRA

Fertilizer applications can cover a wide area of application devices. Many of the VRA technologies for fertilizer applications are similar to weed control (liquid applications) and liming application (dry chemi-

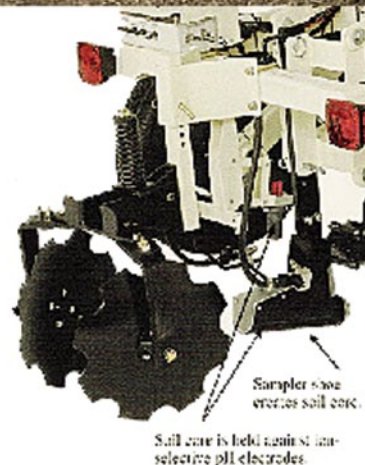

Figure 15. Veris Mobile Sensor Platform (MSP) equipped with “pH Manager” (www.veristech.com/products/soilph.aspx).

cal). Their effectiveness can be complicated based on weather impacts and the nutrient's availability and seasonal cycles. We will look at the major nutrients and why some are more likely to be applied with VRA.

Phosphorus VRA

VRA of phosphorus (P) is probably the second-most-profitable VRA activity. Soil phosphorus is not nearly as transient as soil nitrogen (N), meaning that grid soil tests can be used for a number of years. Also, there is evidence that long-term economic benefits might arise from building up soil-test phosphorus. This capital investment characteristic of soil-test phosphorus means that it is often profitable to uncover the intrinsic differences in soil-test phosphorus within a field — at least at one point in time.

Nitrogen VRA

The adoption of VRA nitrogen (N) management by producers is low, despite the potential economic and environmental benefits of this practice. A major obstacle is the recommended nitrogen fertilizer rates based on yield goal are often poorly correlated with actual economically optimum nitrogen rates.

Nitrogen response patterns are often field- and season-specific and can vary widely within the same field, further complicating the development of prescription maps. Side-by-side comparisons of uniform and VRA-N management have revealed no consistent advantages for either strategy in yields achieved, profitability, whole-field nitrogen usage, or nitrogen-use efficiency by plants. In the future, a better understanding of temporal variation in nitrogen soil test levels, better crop-simulation models, and improved nitrogen-sensing and application equipment may assist producers in capturing the benefits of VRA-N management. Real-time sensors of crops offer the most potential for VRA-N, as these systems are designed to “sense” the nitrogen needs of the crop at the time of application. These systems require well-fertilized areas in the field to calibrate the sensor. Ongoing research will determine if these systems will be widely employed in the future.

Will VRA-N Work?

Every season, corn producers must decide on the correct amount of nitrogen fertilizer to apply to their fields. Today's GPS-enabled application equipment and related precision farming tools have created another

decision for growers: whether to apply nitrogen at a uniform rate or by using VRA within fields.

Tailoring nitrogen application rates to more exactly meet crop needs should increase profitability, reduce environmental risk, and may result in higher and more consistent grain quality. However, adoption rates for variable nitrogen application have lagged behind those of other precision farming practices.

Recent university research has revealed why: Managing nitrogen in subregions of fields or even in whole fields is a complex process and challenges some long-held nutrient management beliefs. The key to success and eventual adoption of variable-rate nitrogen management will be the development of decision-making criteria that can accurately predict nitrogen rates for subregions of corn, wheat, rice, cotton, and other crops that are economically optimum and environmentally sustainable.

Current VRA-N Strategies

In the mid-1990s, many researchers expected that developing accurate nitrogen recommendations for subregions of fields would be a certainty. Part of this optimism stemmed from the development of many new tools to routinely measure site characteristics that directly affected crop-nitrogen status, soil-nitrogen supply, and crop productivity. These included pre-season and late-spring soil nitrate tests, late-season stalk nitrate tests, remote sensing of crop and soil properties, site-specific data from yield monitors, and soil electrical conductivity maps. However, for these new spatial tools to be effective, the prescribed nitrogen maps they helped produce had to be accurate and applicable from year to year.

Proactive Strategies

The first variable-rate nitrogen strategies took a proactive, prescriptive approach. Fields were divided into smaller subregions and methods developed for whole-field nitrogen management were applied to these individual “management zones.” The variable nitrogen rate prescription map was developed prior to the growing season and fertilizer was applied at the usual time(s). These approaches included the use of grid soil sampling and crop productivity zones. In general, many studies found:

- There is no consistent income advantage for either VRA or uniform-rate nitrogen strategies.
- Yields were not impacted by nitrogen strategy.

- Whole-field nitrogen rates were similar for either strategy.
- Postseason soil-nitrate levels were not appreciably reduced when using VRA-N.
- Either strategy could outperform the other in a particular growing season, depending on crop-related conditions.

Clearly, much additional research is needed to be able to predict nitrogen response patterns on a field scale.

Reactive Strategies

A second approach to site-specific nitrogen management involves reacting to actual nitrogen levels in crop fields during the growing season. Crop nitrogen status is monitored in near-real time, and nitrogen is applied only when and where it is needed. With this method, plant or canopy reflectance of light or chlorophyll content is used to indicate plant nitrogen stress. This approach can utilize remotely sensed crop canopy imagery and typically requires the presence of an adequately nitrogen-fertilized “reference strip” within the field. Interestingly, these optical methods create in-season nitrogen prescription maps that are based on crop nitrogen stress rather than predicted yield levels.

VRA-N Considerations for the Future

New nitrogen management strategies will be adopted if they reduce risk and are affordable, accurate, easy-to-use, and environmentally sustainable. For corn production, this probably precludes the use of grid soil sampling for nitrogen content due to the cost of sampling and analysis and the limited life of sample results. Future use of any nitrogen-recommendation algorithm based on yield goal, productivity index, or soil type should be carefully evaluated for accuracy and reliability under field conditions.

The technology available to vary nitrogen fertilizer rates within a field likely exceeds the knowledge of how to best use it. When finally successful, variable-rate nitrogen strategies will need to be carefully customized to fit local soil, climatic, environmental, and agronomic conditions.

On-the-Go Crop Sensing for VRA-N

The GreenSeeker (www.ntechindustries.com/greens-eecker-home.html) and OptRx Crop Sensor (AgLeader; www.agleader.com/products/directcommand/optrx/)

are two commercially available sensor-based systems being used for VRA-N. Both sensors indirectly assess the level of chlorophyll (greenness) and amount of biomass by calculating a vegetation index, NDVI (Normalized Difference Vegetation Index).

Nitrogen Application for Grain Crops

For nitrogen applications utilizing the GreenSeeker (figure 16), the concept is that the amount of fertilizer needed at a particular location within the field can be determined by implementing a nitrogen-rich strip at planting or shortly thereafter and comparing spatial variability of crop growth across the field to crop growth from the nitrogen strip. The nitrogen-rich strip provides an area in which nitrogen is not the yield-limiting factor.

A nitrogen-rich strip is implemented by selecting one strip that transverses the field (typically one pass of the fertilizer application equipment) to receive a complete



Figure 16. Optical sensor measuring Normalized Difference Vegetation Index (NDVI; GreenSeeker) and adjusting VRA nitrogen on wheat.

nitrogen application at planting. Then at side dress, NDVI readings are collected from the nitrogen-rich strip to calibrate the crop sensor system. Subsequently, as the fertilizer applicator covers the field, the sensors read NDVI values, compare them to the NDVI values from the nitrogen-rich strip, and apply an adjusted amount of nitrogen.

For example, if the NDVI value in the nitrogen-rich strip was 0.5 but was 0.6 at a particular location within the field, no nitrogen would be applied because the sensor determined that sufficient nitrogen is already available. Conversely, if the nitrogen-rich strip had an 0.5 NDVI reading but another location within the field had an 0.4 NDVI, then nitrogen would be applied in that area.

Recently, the use of a ramped calibration strip has been recommended. Instead of the nitrogen-rich strip consisting of one rate across the field, a range of nitrogen rates is applied across the field. This provides a benefit in that growers can see actual response to a range of nitrogen rates and when they are setting ranges for variable-rate application, they have more information about how to appropriately establish the breaks for the assorted nitrogen rates.

Uses in Cotton Production

There is interest in using the GreenSeeker systems for the application of plant-growth regulators and defoliant to cotton production. The principle behind these applications is that higher NDVI readings reflect higher biomass; areas with higher biomass would require higher rates of both plant growth regulators and defoliants. Research is being conducted to determine the most efficient method of using on-the-go sensors for variable-rate application of these products.

Economic Comparison of VRA Research Findings

Lambert and Lowenberg-DeBoer (2000) compiled 108 studies that reported economic figures from research endeavors. Their finding showed that 63 percent indicated positive net returns for a given precision farming technology, while 11 percent indicated negative returns, and 27 articles indicated mixed results (26 percent).

For all precision farming technology combinations identified, more than 50 percent of the studies reported positive economic benefits, except for VRA yield monitor

systems where only yield data was used to develop a prescription map (table 1). About 60 percent of the VRA studies of nitrogen or NPK applications reported economic gains.

When all the studies are categorized by crop (table 2), corn, soybean, and sugar beet studies showed positive profits in over two-thirds of cases. Only 20 percent of the studies on wheat showed profits, and in another 20 percent, results were mixed. Of those studies reporting numerical estimates for VRA-N, 72 percent of corn studies and 20 percent of wheat studies showed profits.

The level of returns varies widely by crop and technology. The average return on VRA-N in sugar beet studies is \$74 per acre (net \$48.25). Estimated returns to lime VRA based on 2.5-acre grids varied from \$3.46 to \$5.07 per acre. The reported range of VRA plant populations for corn is \$0.97 to \$2.72 per acre. VRA weed-control returns varied depending on weed pressure and patchiness from \$0.01 to \$11.67 per acre.

Mixed results indicated that although there may have been some positive net returns, Lambert and Lowenberg-DeBoer (2000) did not have enough confidence

Table 1. Summary of reported economic benefits for precision farming (PF) technology combinations (Lambert and Lowenberg-DeBoer 2000).

Technology	Reported economic benefit (%)			
	Yes	No	Mixed	Base
VRA-N	63	15	22	27
VRA-P, K	71	29	0	7
VRA-lime	75	0	25	4
VRA-NPK, general	75	8	16	24
Soil sensing	20	40	40	5
VRA-seeding	83	17	0	6
VRA-weeds, pests	86	14	0	7
VRA-GPS systems	100	0	0	3
VRA-irrigation	50	0	50	2
VRA-yield monitor systems*	43	14	43	7
PF technology summary	77	0	23	14
PF/VRA technologies combined	63	11	27	108

*These figures considered reports estimating the benefits of yield monitors in conjunction with VRA, not yield monitors alone.

Table 2. Profitability summary of precision farming technologies and crops where technologies were implemented (Lambert and Lowenberg-DeBoer 2000).[†]

Technology	Crop	Reported economic benefit (%) from precision farming technology			
		Yes	No	Mixed	Studies
VRA-N	Corn	72	6	22	18
	Potato	.	N ^a	.	1
	Wheat	20	40	40	5
	Soybean	.	.	M ^b	1
	Sugar beet	Y ^c	.	.	1
	Corn-soybean	Y	.	.	1
VRA-P, K	Corn	60	40	.	5
	Potato	Y	.	.	1
	Corn-soybean	Y	.	.	.
	Wheat	.	.	M	1
VRA-lime	Corn	Y	.	.	2
	Corn-soybean	Y	.	.	1
Soil sensing	Corn	Y	N	M	3
	Sugar beet	.	N	.	1
	Corn-soybean	Y	.	.	1
VRA-seeding	Corn	83	17	.	6
VRA-weeds, pests	Corn	Y	.	.	2
	Wheat	Y	N	.	2
	Soybean	Y	.	.	2
VRA-irrigation	Corn	Y	.	.	1
	Corn-cotton	.	.	M	1
VRA-yield monitor	Corn	Y	N	M	3
	Sorghum	.	.	M	1
	Cotton	.	.	M	1
VRA-general	Barley	Y	.	.	1
	Corn-soybean	Y	.	.	3
	Corn-rice	Y	.	.	1
	Corn	63	13	25	8
	Potato	Y	.	M	2
	Wheat	60	20	20	5
	Sugar beet	Y	.	.	3
	Oats	Y	.	.	1

^aN = no reported benefit.

^bM = mixed results.

^cY = reported benefit.

to support the general assertion that similar results could be achieved under similar circumstances. Oftentimes, conclusions in these reports indicated that more research needed to be done in order to reach a valid conclusion.

Summary

Variable-rate application of cropping inputs such as seed, lime, fertilizers, and pesticides is one management strategy to address the variability that exists within agricultural fields. Adjusting the rate of inputs on the go requires sensors, electronic controllers, and mechanical drive systems, which act as the VRA technologies. Two approaches to VRA are sensor-based and map-based. Each method has its benefits and drawbacks. In the future, the best approach may use a combination of both.

Currently, most of the VRA technologies are commercially available, but they need an investment of time and thought of how to implement the prescription maps. The decision to use VRA and the prescriptions for varying inputs are truly site-specific. Not every farm or field will show an economic benefit from VRA, but these technologies offer opportunities for growers to increase both the production and environmental efficiencies of crop production and should be carefully evaluated.

Whatever your level of technology usage today, it is valuable to stay informed with regard to the changes occurring in production agriculture. Not all new technologies offer clear and sufficient economic benefits to all producers. However, being familiar with the technology will allow you to decide which pieces of the precision puzzle may be used to help you survive and thrive in a competitive world.

Acknowledgements

The authors would like to express appreciation for the review and comments made by Randal K. Taylor, professor/interim head, Biosystems and Agricultural Engineering, Oklahoma State University; Keith Balderson, Extension agent, agriculture and natural resources, crop and soil sciences, Virginia Cooperative Extension Essex County Office; and Bruce Jones, Extension agent, agriculture and natural resources, crop and soil sciences, Virginia Cooperative Extension Appomattox County Office.

Resources

Adapted From These Resources

- Adamchuck, V. I. 2005. Characterizing Soil Variability Using On-the-Go Sensing Technology. International Plant Nutrition Institute, Site-Specific Management Guidelines, SSMG-44. Norcross, Ga. [www.ipni.net/ppiweb/ppibase.nsf/b369c6dbe705dd13852568e3000de93d/8bfeba411afe85e28525718000690a10/\\$FILE/SSMG-44.pdf](http://www.ipni.net/ppiweb/ppibase.nsf/b369c6dbe705dd13852568e3000de93d/8bfeba411afe85e28525718000690a10/$FILE/SSMG-44.pdf)
- Adamchuck, V. I., and P. Jasa. 2002. On-the-Go Vehicle-Based Soil Sensors. University of Nebraska-Lincoln Extension EC02-178. www.ianrpubs.unl.edu/epublic/live/ec178/build/ec178.pdf
- Adamchuck, V. I., and J. Mulliken. 2005. Site-Specific Management of Soil pH (FAQ). University of Nebraska-Lincoln Extension EC05-705. www.ianrpubs.unl.edu/epublic/live/ec705/build/ec705.pdf
- Doerge, T. A. 2002. Variable-rate nitrogen management creates opportunities and challenges for corn producers. *Crop Management* doi:10.1094/CM-2002-0905-01-RS. www.plantmanagementnetwork.org/pub/cm/review/variable-n/
- Humburg, D. 1990. *Variable Rate Equipment — Technology for Weed Control*. International Plant Nutrition Institute, Site-Specific Management Guidelines, SSMG-7. Norcross, Ga. [www.ppi-ppic.org/ppiweb/ppibase.nsf/\\$webindex/article=A172CE4C8525696100631668C0F666E3](http://www.ppi-ppic.org/ppiweb/ppibase.nsf/$webindex/article=A172CE4C8525696100631668C0F666E3) or www.agriculture.purdue.edu/ssmc/
- Lambert, D., and J. Lowenberg-DeBoer. 2000. *Precision Agriculture Profitability Review*. Site-Specific Management Center, School of Agriculture, Purdue University. www.agriculture.purdue.edu/ssmc/Frames/newsoilsX.pdf

VCE Publications on Precision Farming

- Precision Farming: A Comprehensive Approach*. VCE Publication 442-500. <http://pubs.ext.vt.edu/442/442-500>
- Precision Farming Tools: GPS Navigation*. VCE Publication 442-501. <http://pubs.ext.vt.edu/442/442-501>
- Precision Farming Tools: Yield Monitor*. VCE Publication 442-502. <http://pubs.ext.vt.edu/442/442-502>
- Precision Farming Tools: Global Positioning System (GPS)*. VCE Publication 442-503. <http://pubs.ext.vt.edu/442/442-503>
- Precision Farming Tools: GIS – Mapping Geo-Referenced Data*. VCE Publication 442-504.
- Precision Farming Tools: Remote Sensing*. VCE Publication 442-506.
- Precision Farming Tools: Map-Based Versus Sensor-Based*. VCE Publication 442-507.
- Precision Farming Tools: Soil Electrical Conductivity*. VCE Publication 442-508. <http://pubs.ext.vt.edu/442/442-508>
- Interpreting Yield Maps: “I Gotta Yield Map — Now What?”* VCE Publication 442-509. <http://pubs.ext.vt.edu/442/442-509>
- Investing in GPS Guidance Systems?* VCE Publication 448-076. <http://pubs.ext.vt.edu/448/448-076>