

REFLECTIONS OF COLOR AND LIGHT

CHRISTOPHER PIETSCH

Thesis submitted to the faculty of the Virginia Polytechnic Institute and State University
in partial fulfillment of the requirements for the degree of:

Master of Architecture in
Architecture

Steven R. Thompson, Chairman

William U. Galloway

Patrick A. Doan

May 30th, 2014
Blacksburg, VA

Keywords: Architecture, Color, Light, Reflection

REFLECTIONS OF COLOR AND LIGHT

CHRISTOPHER PIETSCH

ABSTRACT

An integral part of human vision is the perception of color through the reflection of light. At any moment the human eye is receiving a complex polychromatic reflection of its environment, and the human mind is perceiving many hundreds or thousands of colors.

In architecture, light is often a primary consideration in a design, but color is rarely discussed. It makes its presence known, however, as the light entering into a building will carry with it the reflections of the environment. The elements of architecture appear quite different at varying times of the day; at varying times of the year. Even at the same time of day two walls painted the same color will appear as two different colors if placed in different light conditions.

This thesis attempts to capture this phenomenon and elaborate on the possibilities of working with light through reflection. It is not meant to give a specific answer, but rather to show the results of a search to find a way of working with light through color.

ACKNOWLEDGEMENTS

I would like to thank Steve Thompson, Bill Galloway, and Patrick Doan for their guidance and support.

I would like to thank Russell Karn and Martin Hedrick for their help and hard labor when we were building the apertures at RDF.

I would like to thank my family for their support throughout my education.

I would like to thank my father for watching This Old House with me on Sunday mornings when I was growing up and for showing me how to make things.

In memory of my father, James Dillon Pietsch.

“In visual perception a color is almost never seen as it really is
--as it physically is.
This fact makes color the most relative medium in art.”

-Josef Albers, *Interaction of Color*, 1963

I was brought up in my architectural education that intrinsic material color was considered more honest and more pure than applied color, and that if you were going to paint something anything, you had to paint it white. What I am coming to realize is that this is not a neutral position, and perhaps requires some reexamination. The interaction of light with any material produces color reflection, and this reflection has a primary impact on our perception of a space. When shown a picture of an all concrete room, with its blue gray light, many would say the room looks “cold.” When shown a room clad with maple plywood with a hardwood floor, many would say the room looks “warm.” Immediately material choice has had a non-neutral effect on perception, in this case on color temperature perception. What I am finding out now is that the light that enters these already non-neutral rooms is itself non-neutral. In a lush, rural landscape the blue reflection of the sky and the green reflection of the landscape will already have a dramatic impact on any architectural space through its effect on both the exterior and the light coming through any openings. In an urban environment, this effect is even more complex. We live in a world of incredibly complex polychromatic reflection. Josef Albers writes in *Interaction of Color* that “color is the most relative medium in art.” In my own studies, I have found that through the interaction of light and material, color is the most relative and least understood medium in architecture.

CONTENTS

Color Atmospheres:	1
A Way to Study Color:	11
A Room of Color:	35
A Return to the Room:	53
Methods:	65
Sources:	78
List of Images:	80



I: COLOR ATMOSPHERES

The following is a series of studies through models of concrete chapels designed to bring colored light into their interior space. Each chapel has a cannon of light, a suspended truncated pyramid with a color opposition between its exterior and interior surface. The study is based on an exercise in the *Interaction of Color*, where Albers writes:

“To use a theatrical parallel:

A set of 4 colors is to be considered--singly as “actors,” together as “cast.” They are to be presented in 4 different arrangements--as performances.”

09/30/2013

Color Atmosphere: First Attempt
Nested Light Cannon

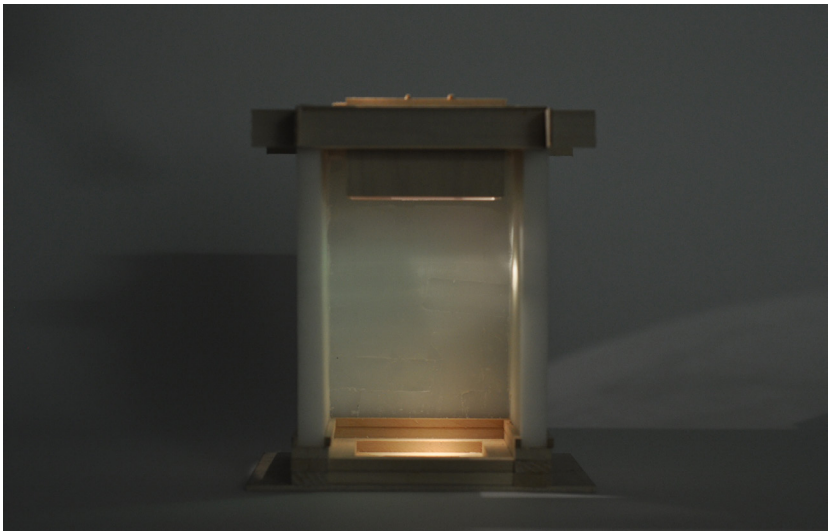
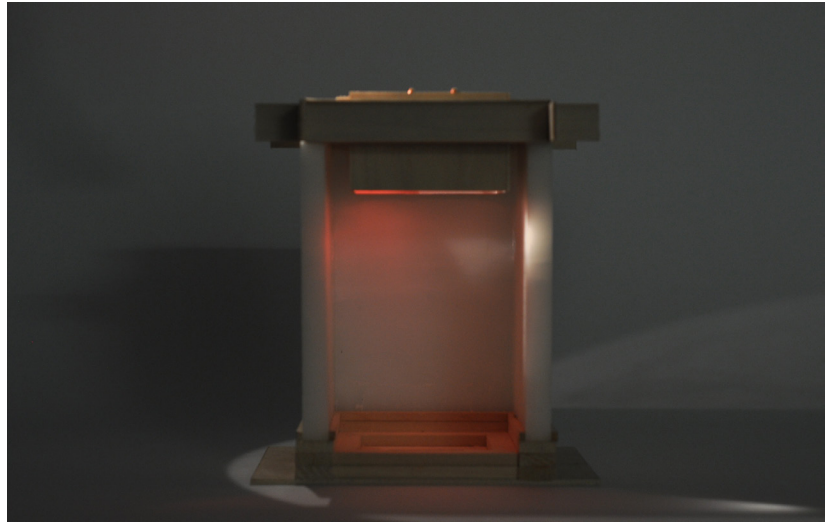
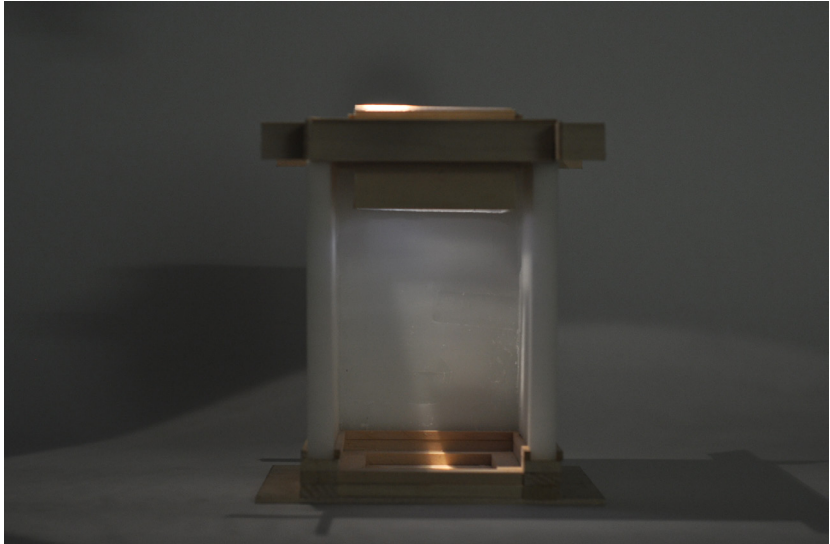

09/30/2013

Color Atmosphere: First Attempt
Inverted Light Cannon

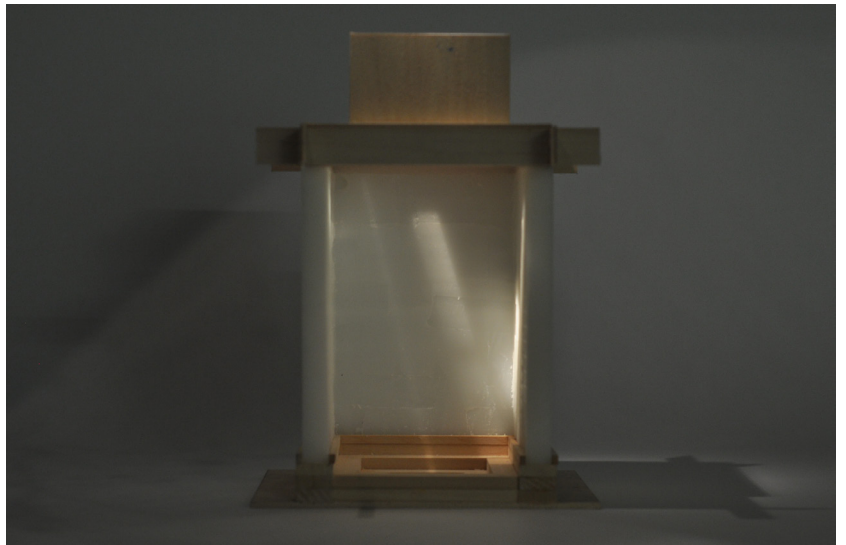
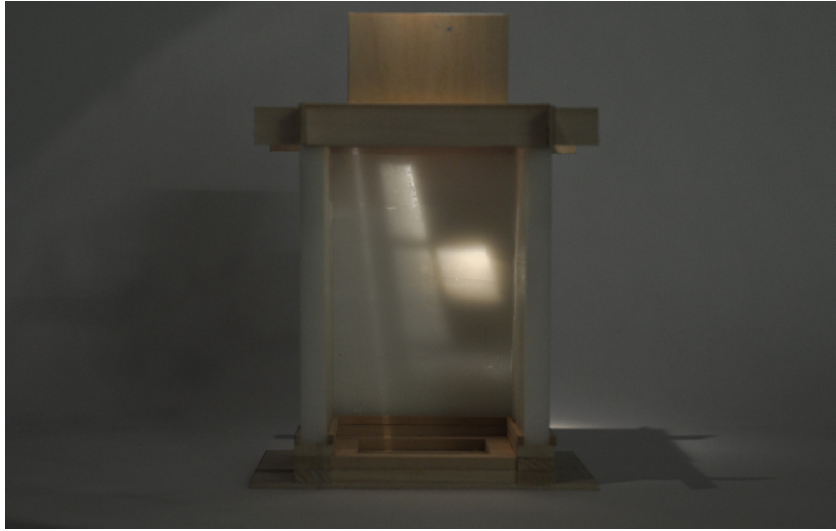

02/13/14, 2:15 p.m.

Color Atmosphere: Second Attempt
Photographed in a snowstorm.

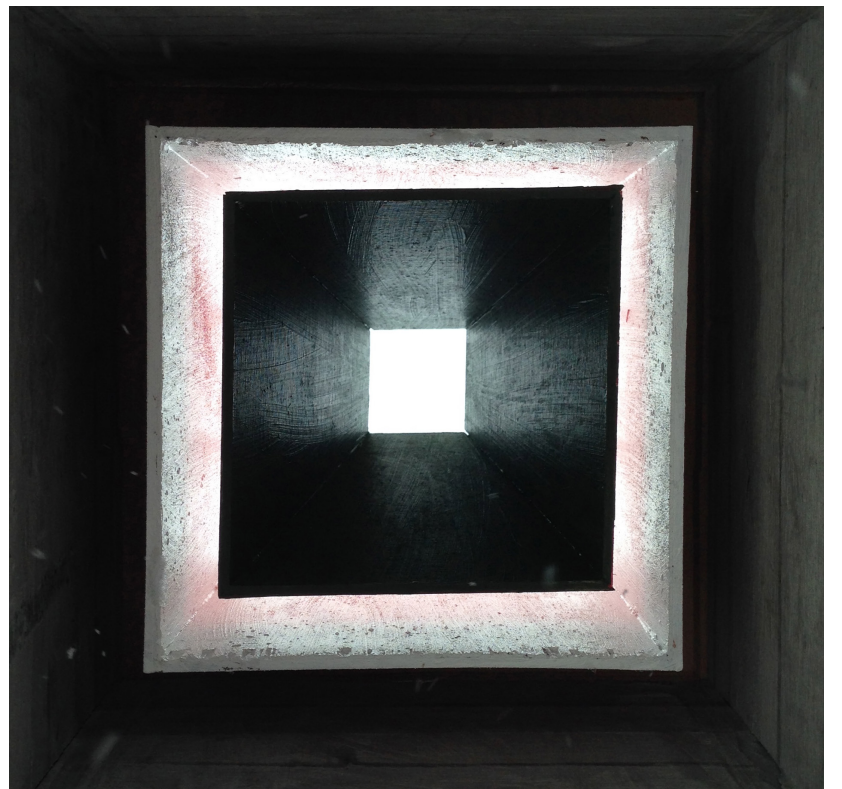
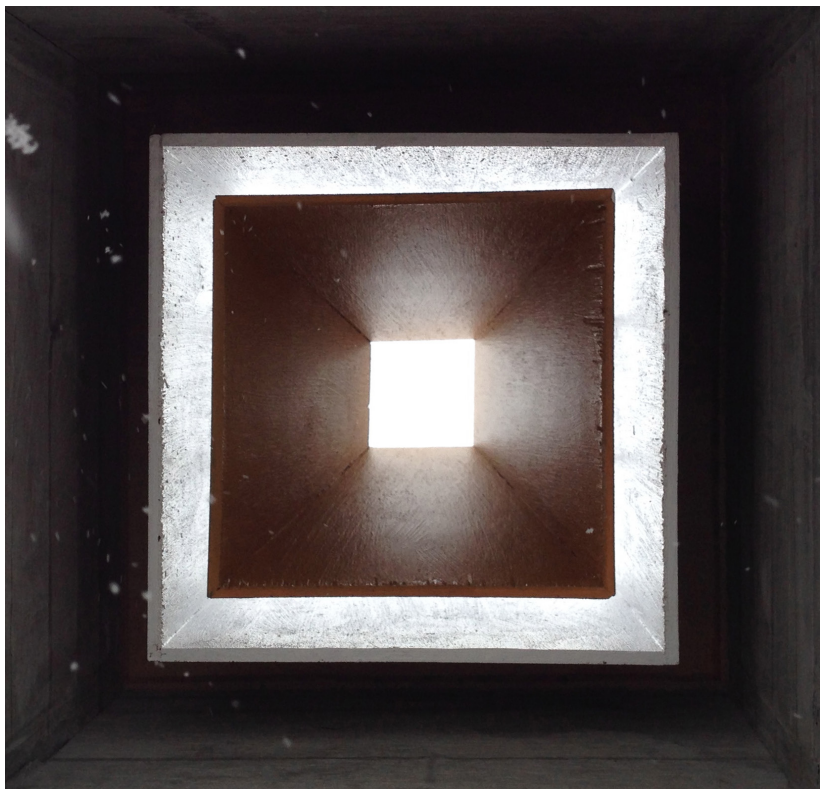
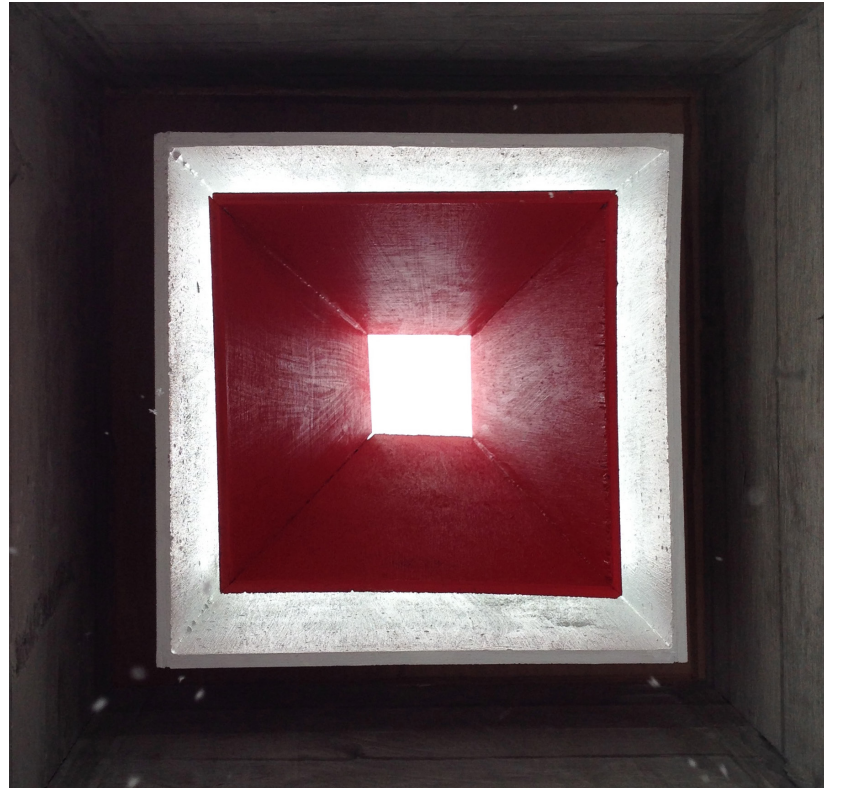
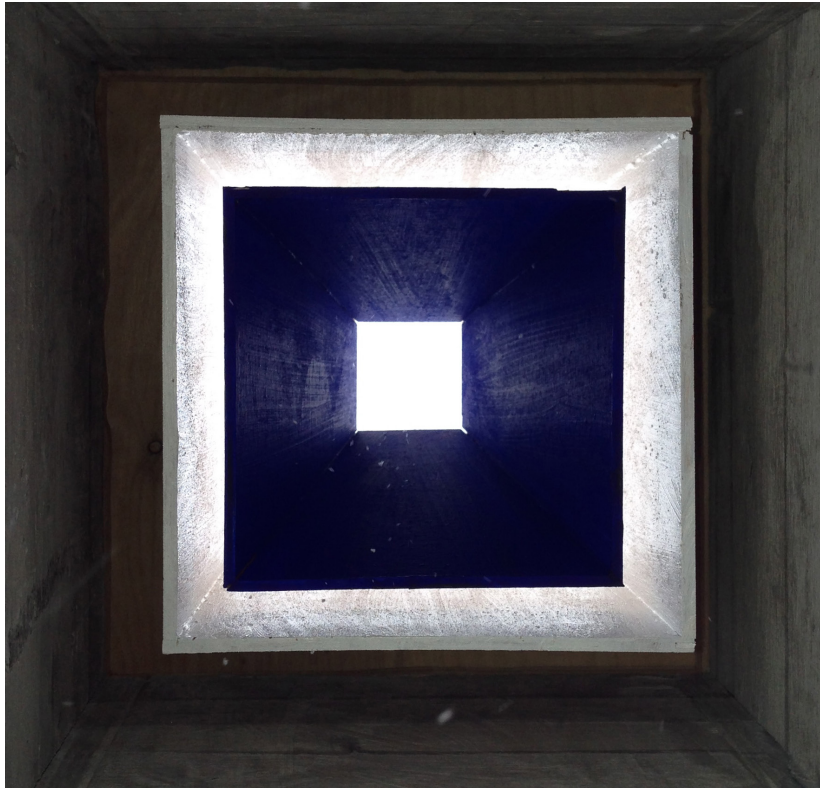

05/04/2014, 5:00 p.m.

Color Atmosphere: Second Attempt
Photographed in partly cloudy skies.

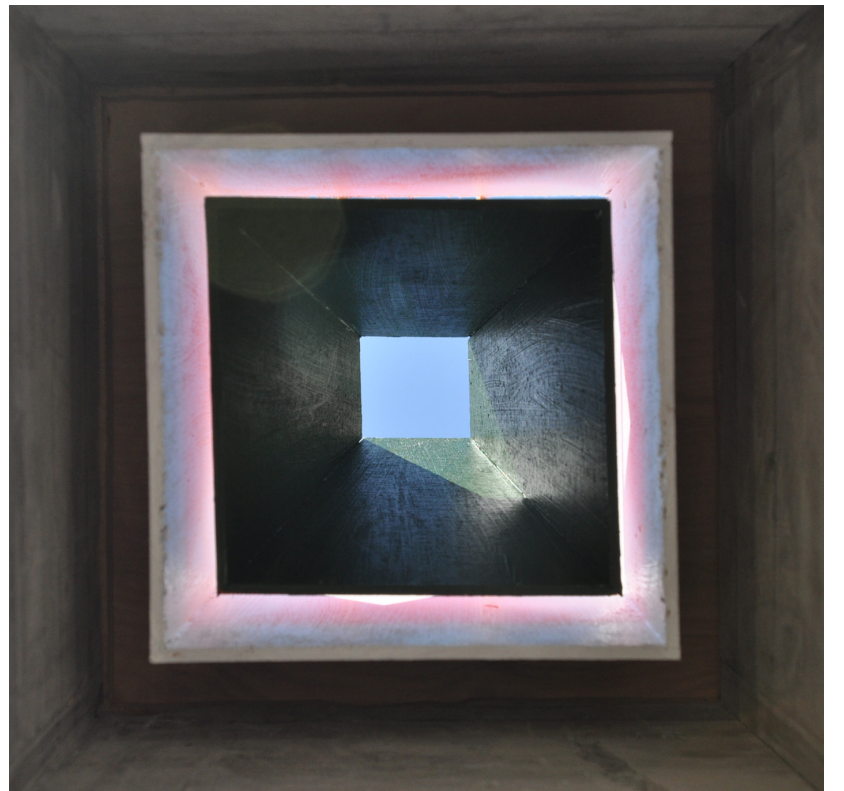
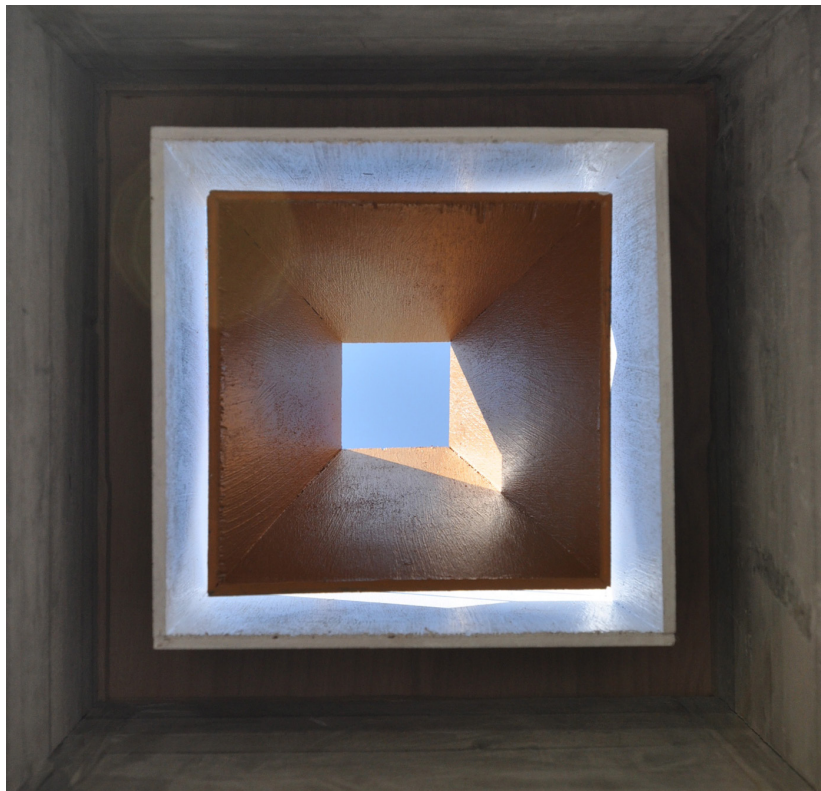
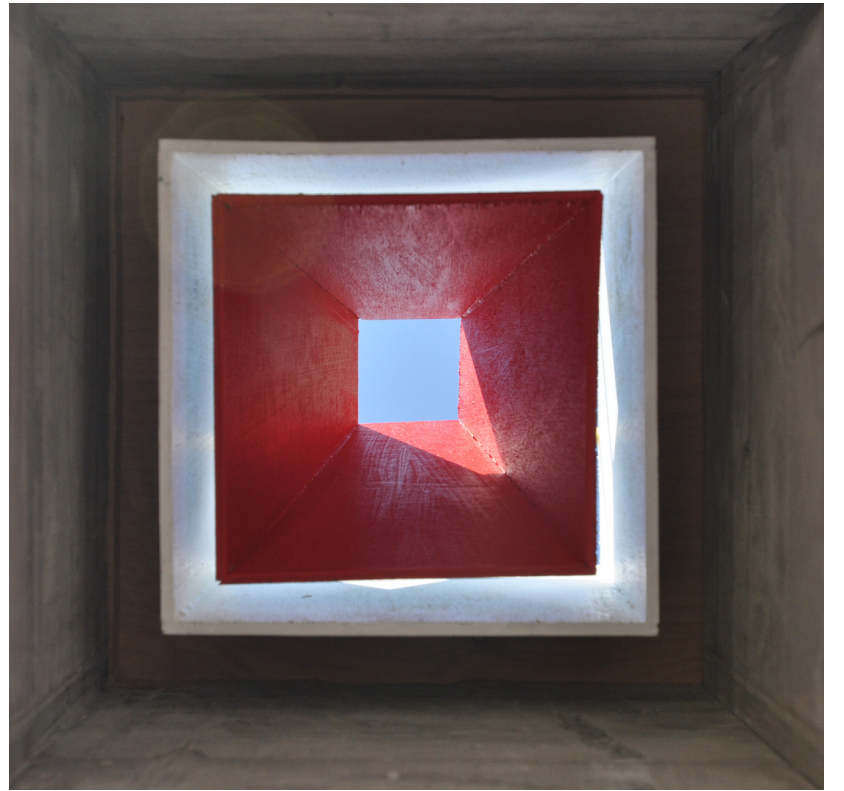
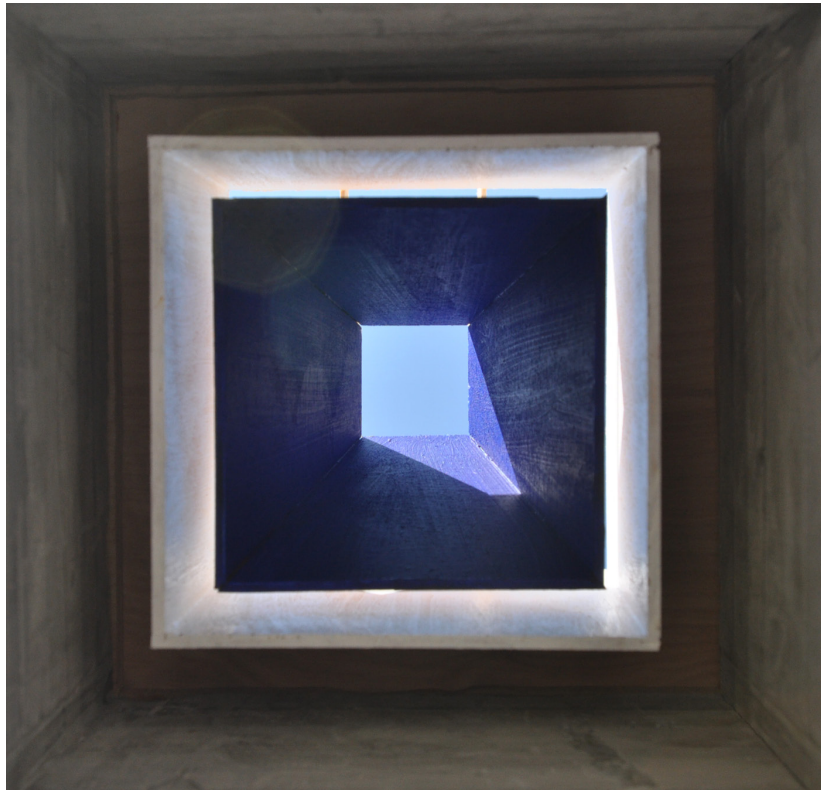



II: A WAY TO STUDY COLOR

Josef Albers writes of the *Interaction of Color*:

“Each exercise is explained--
not to give a specific answer,
but to suggest a way of study.”

As a way to study color at an architectural scale, I built a wall with four openings. The surface that the viewer would see directly from the interior was to be painted white. The surface facing the light and the landscape would be painted one of four fundamental colors, and would give its reflection to the white surface through its interaction with the sun. In this way, I hoped to establish general principles for studying color in architecture.

FUNDAMENTAL TONES

In Goethe's *Theory of Colors*, he identifies four psychological primary colors: yellow, blue, red, and green. He describes yellow and blue as a fundamental psychological opposition, with green being their union and red being their neutralization.

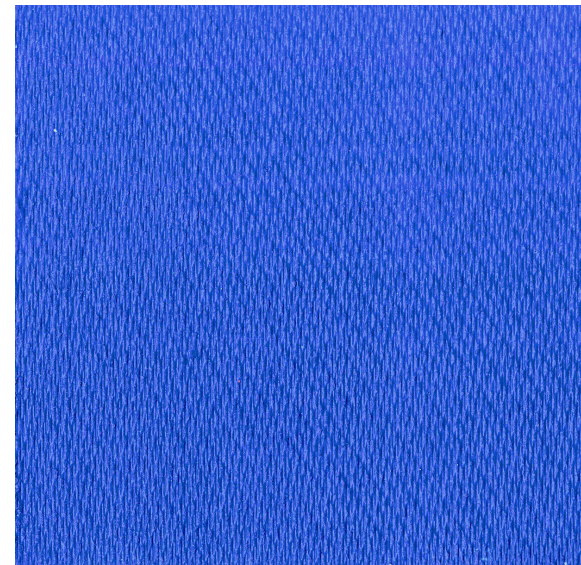
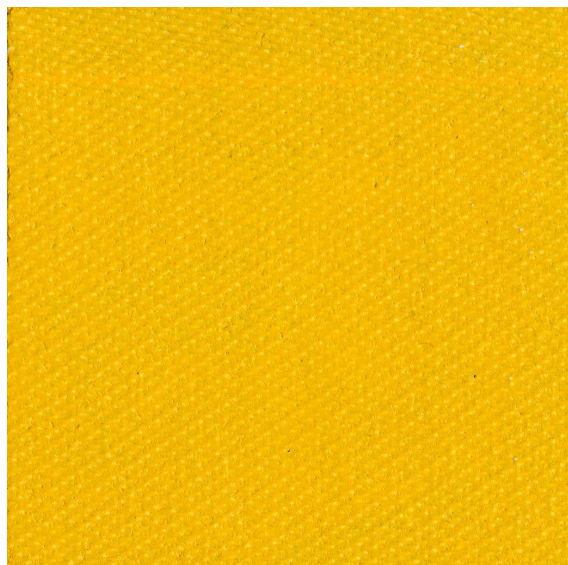
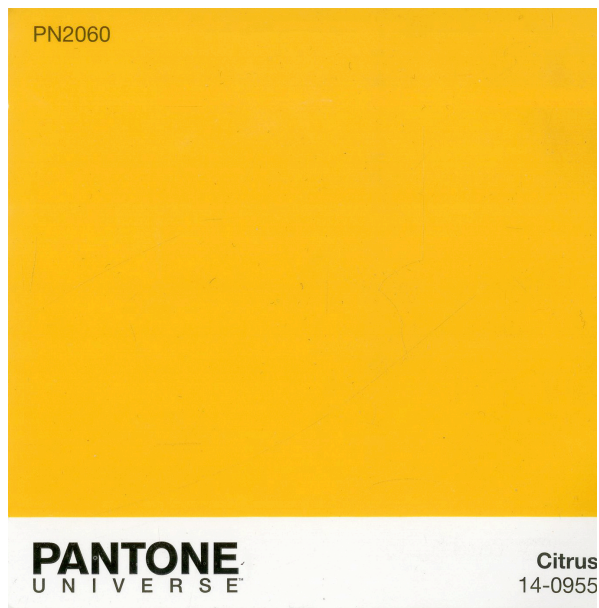

As a way to study color, these four colors will be used as the basis for a study of color reflection through the interaction of light and material. All reflecting surfaces will be painted one of these four colors, all receiving surfaces will be painted white.

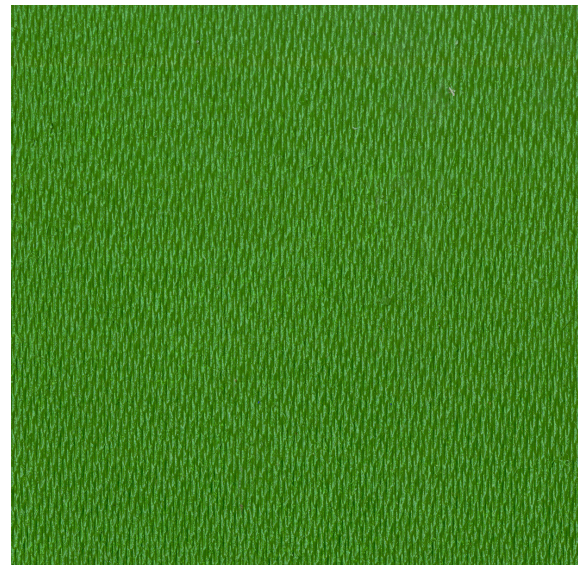
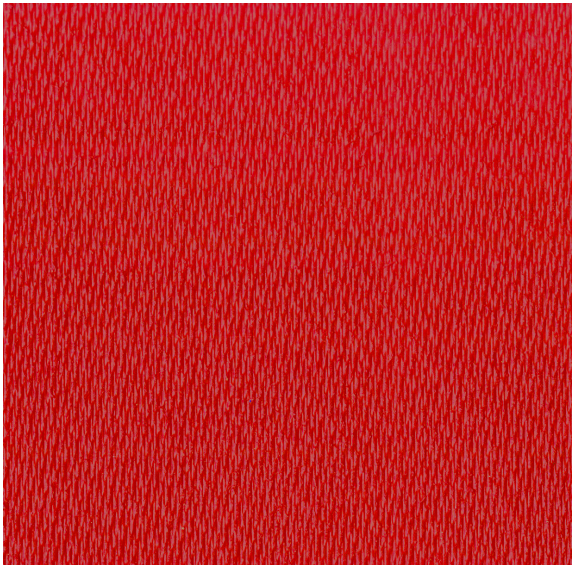



At the Virginia Tech Architecture School's Research and Demonstration Facility (RDF), there are ten 8'x8'x8' concrete test cells used for testing various architectural ideas. Test Cell Number Five has become the site for a full scale installation of the first iteration of an aperture that brings color and light into a space through reflection.

The test cells face southeast, yielding stronger light in the morning and indirect light through the afternoon and evening hours. This means that the light entering through any aperture will not be constant, but rather quite different at various times of the day. In that sense the aperture is something of a constant and the light is the variable in this study.



02/04/2014-02/22/2014
Construction of the opening



03/05/2014
Installation of the color reflectors

COLOR IN DARKENING LIGHT

Test Cell Interior
04/06/2014 from 4:30-7:30 p.m.





04/02/2014, 2:30 p.m.

Receiving surfaces in direct sunlight.

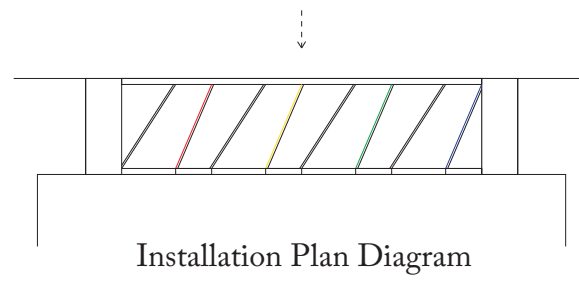

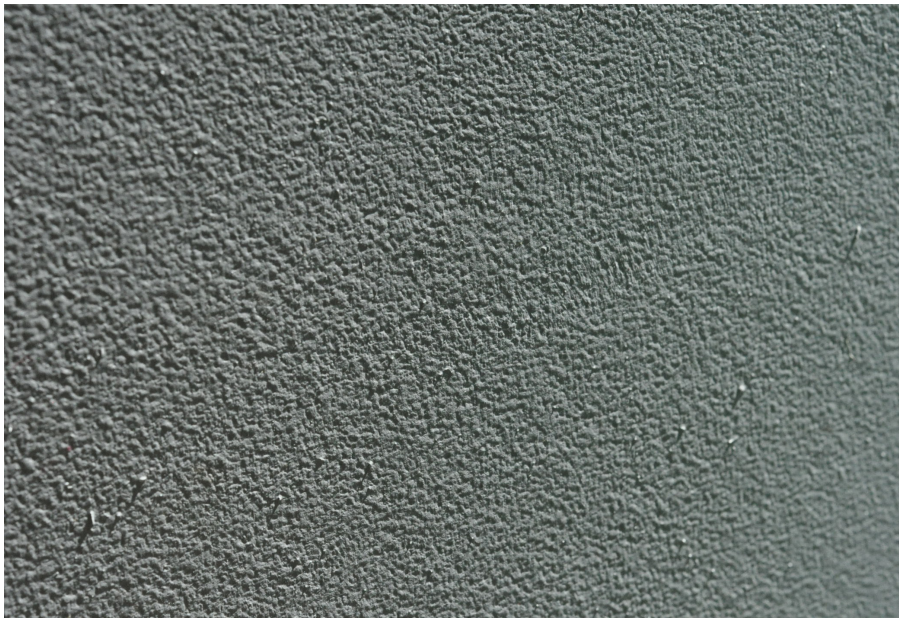

04/03/2014, 10:30 a.m.

Receiving surfaces in indirect sunlight.

Reflecting surfaces in direct sunlight.

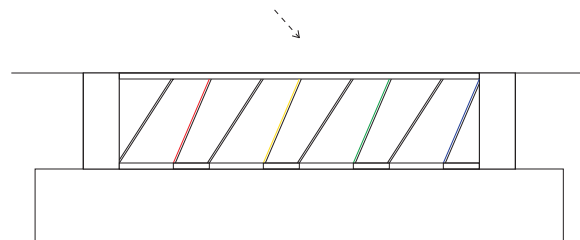

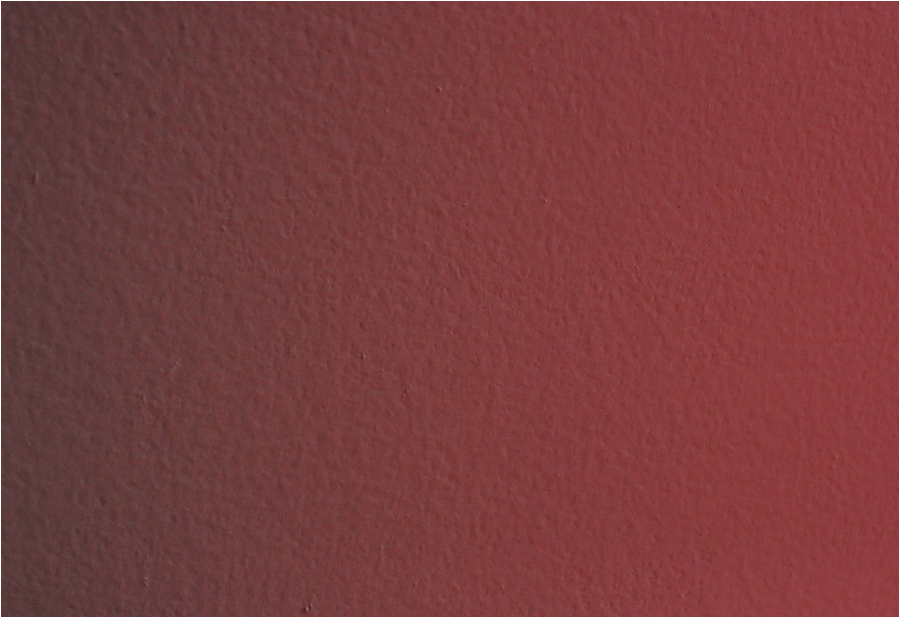

04/03/2014, 10:45 a.m.

Four reds: Red receiving surfaces with modulated reflections of green, blue, red, and yellow masonite panels.

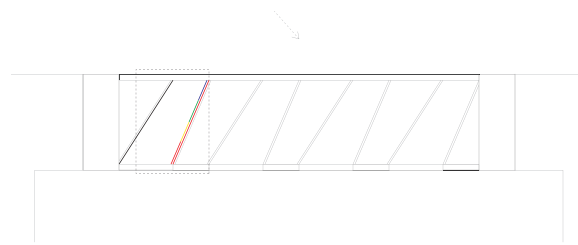

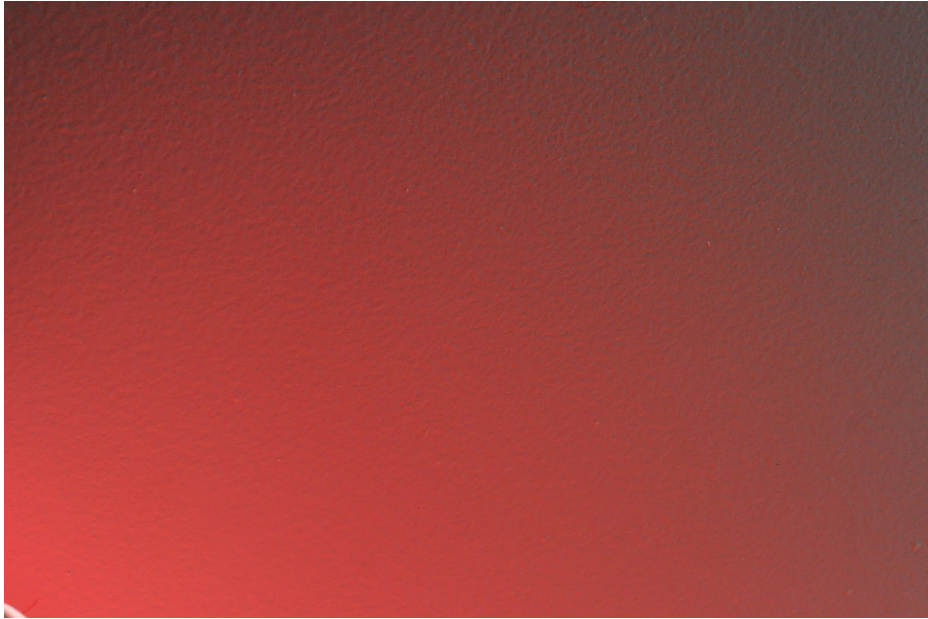

03/24/2014, 11:00 a.m.

Blue in Four Contexts

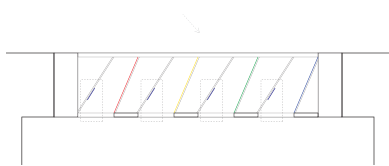

03/24/2014, 11:00 a.m.

Yellow in Four Contexts

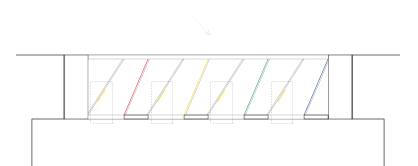

05/05/2014, 11:30 a.m.

Red in Four Contexts

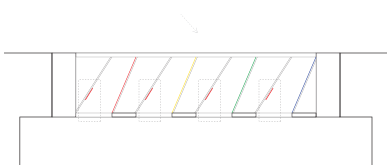
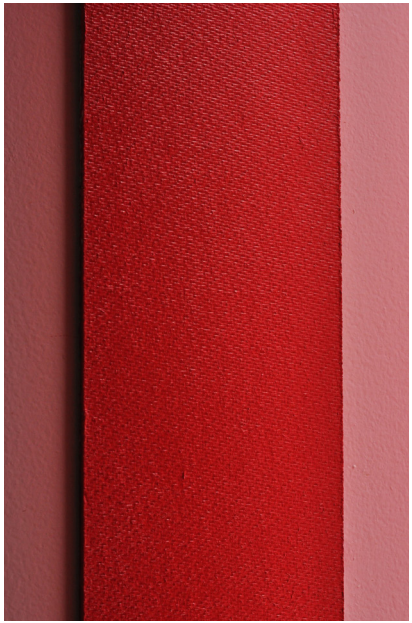

05/05/2014, 11:30 a.m.

Green in Four Contexts

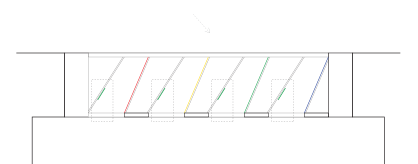
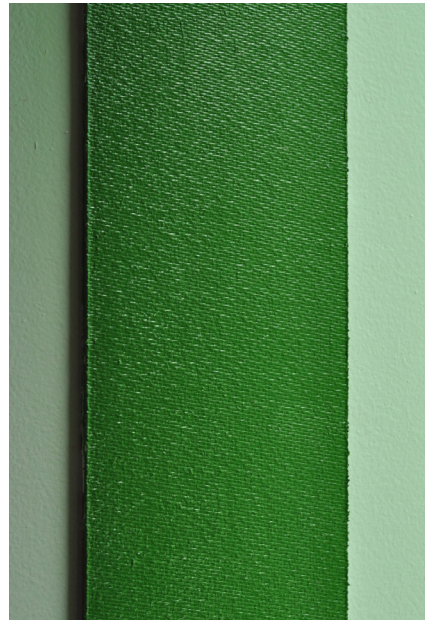

04/03/2014, 11:00 a.m.

The Intensification of Red:

Red masonite panel placed at the sill of the red opening.

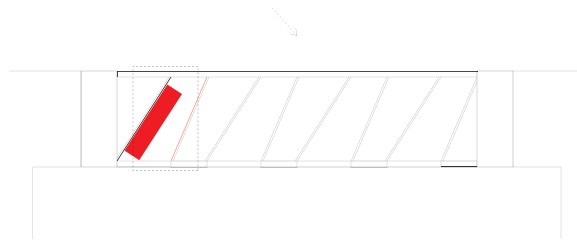



04/03/2014, 11:15 a.m.

Color Mixture: Red, Yellow, and Blue

Yellow opening with red and blue masonite panels added to reflecting surface.

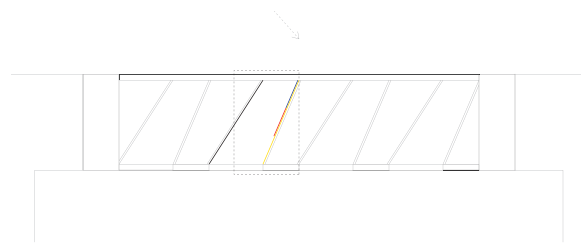





04/14/2014-04/23/2014
Construction of second aperture

III: A ROOM OF COLOR

“The room is the beginning of architecture.

It is the place of the mind.

You in the room with its dimensions, its structure, its light respond to its character, its spiritual aura, recognizing that what ever the human proposes and makes becomes a life.”

-Louis Kahn, *The Room, the Street, and Human Agreement*, 1971

Albers talked of his studies as promoting “thinking in situations.” When considering the making of a room, the quality of light entering the room from the landscape is the specific situation that one must consider primary to the room. This study is a room that gathers light at the edges of its opening, and reflects this light onto a surface within its opening. This specific light, gray green on a sunny day, blue green on a cloudy day, is the fundamental quality of the room. Through color reflection, it became possible to mitigate or intensify this specific condition.

04/23/2014, 8:00 p.m.

First installation of Light Apparatus

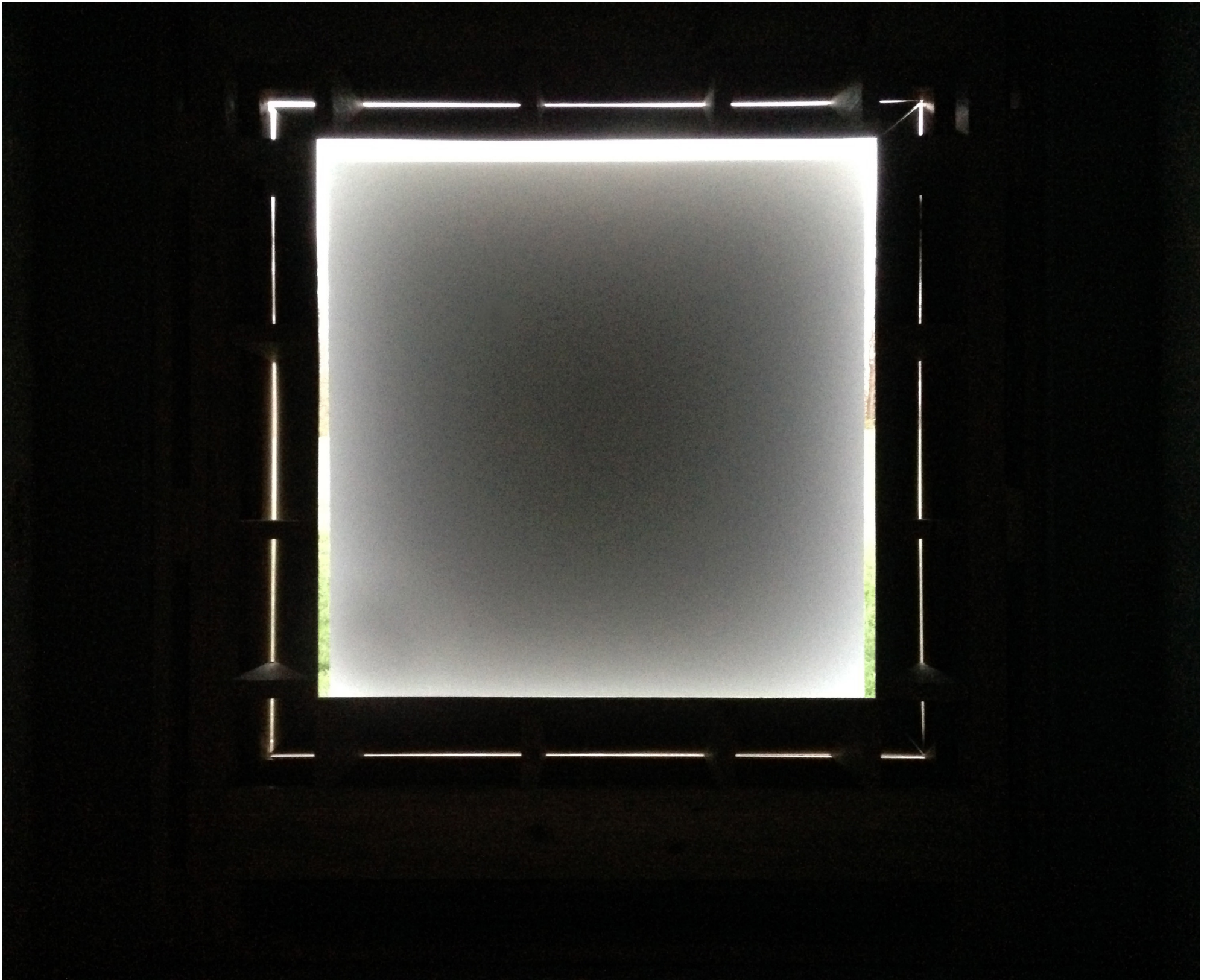

EFFECTS OF POSITIONING/PROXIMITY

05/04/2014

Apparatus hanging at distances varying from 4.25"-1.125"
from reflecting surface.

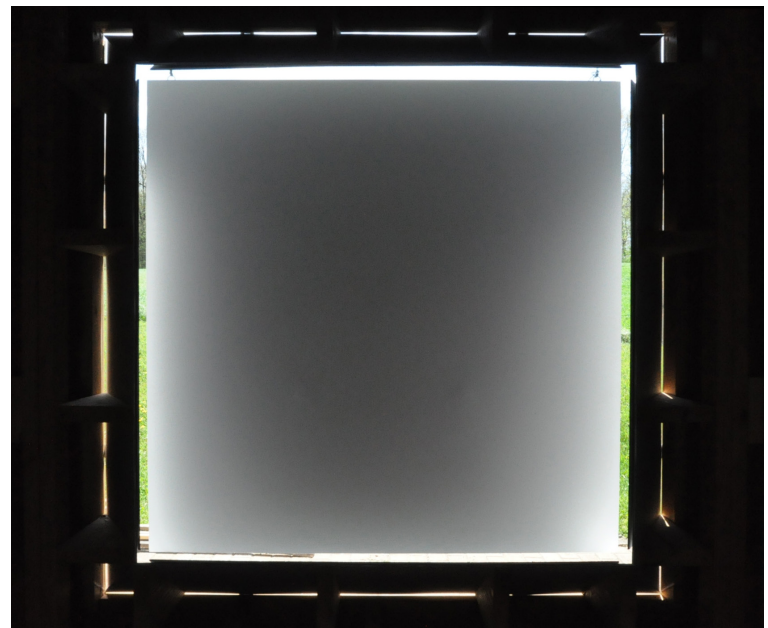

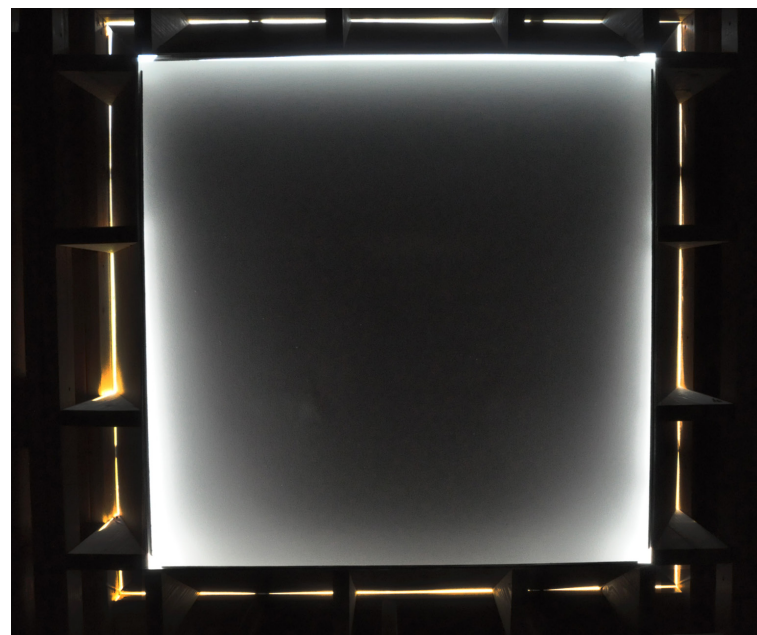
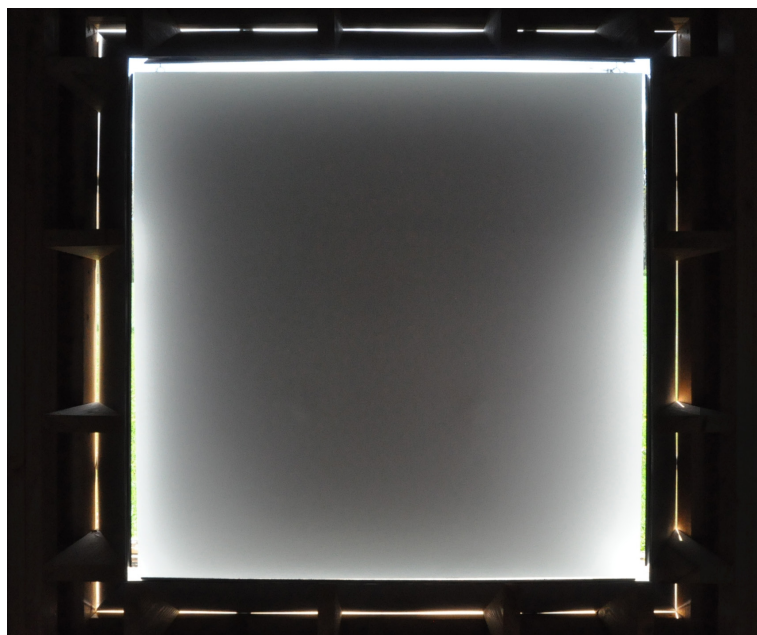

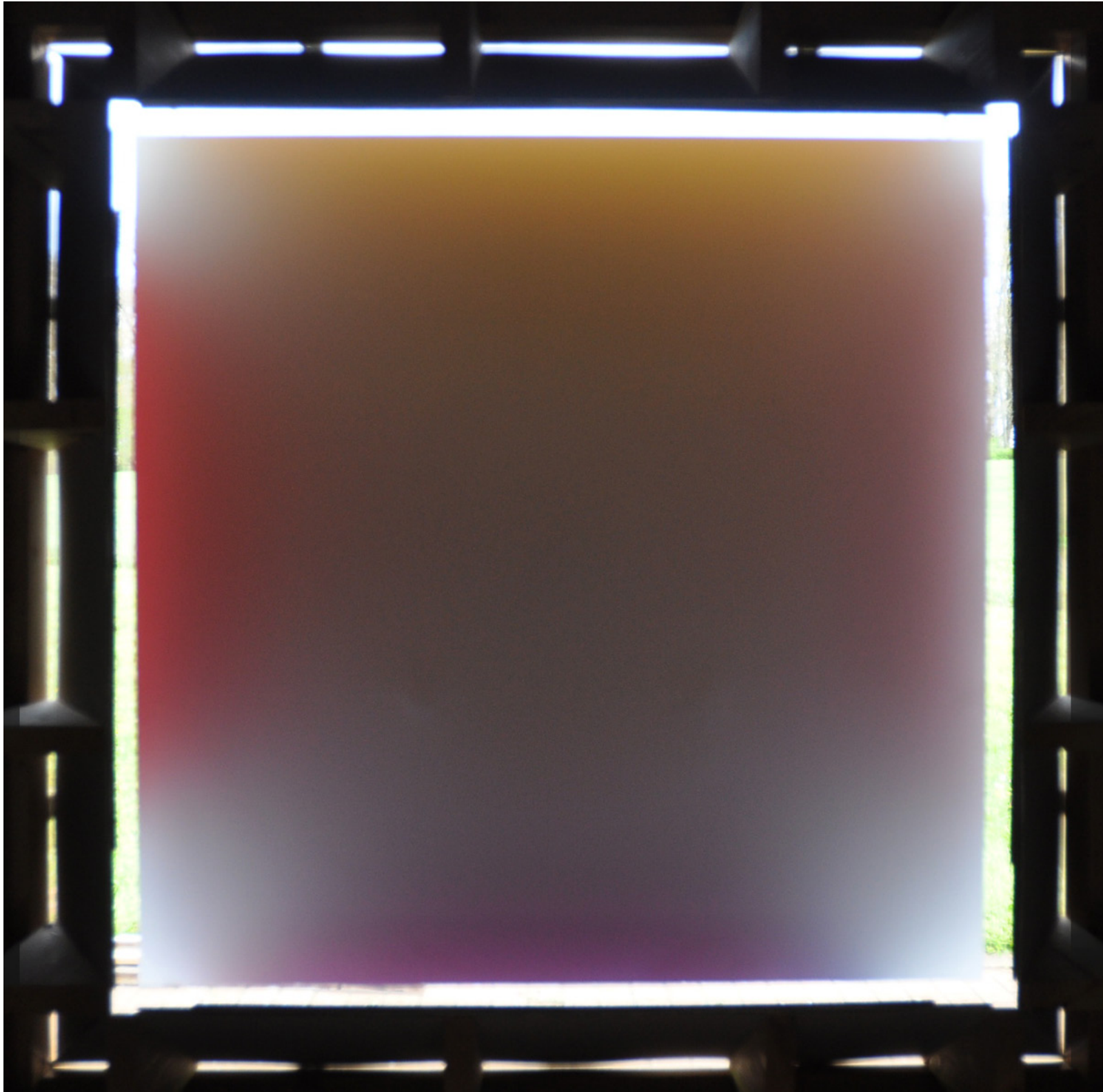

05/01/2014, Afternoon
First Color Arrangement

COMPOSITIONS

After establishing the opening, it became clear that there was already a specific quality of light entering the room. It was highly variable depending on the time of day and the weather, ranging from a light grey with subtle hues of green on a sunny day to a darker grey with a blue hues on a cloudy or rainy day. Given this condition, color reflections have the capacity to alter the light quality of the room, whether intensifying an already cool light-color condition or to mitigate this towards a warmer quality.



05/01/2014, Afternoon
Yellow over Yellow

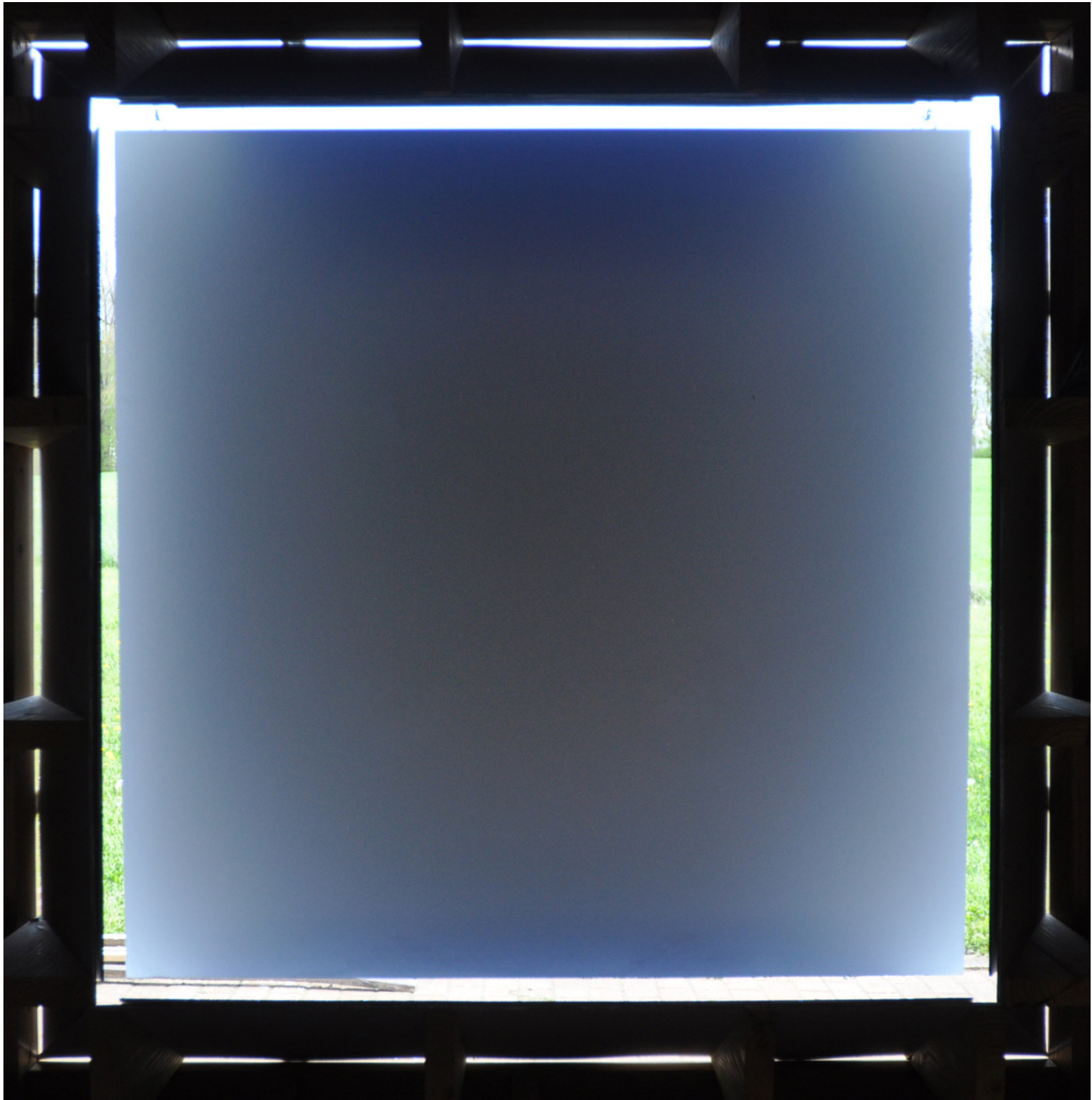

05/02/2014, Morning
Blue Over Blue



05/02/2014, Morning
Yellow over Blue

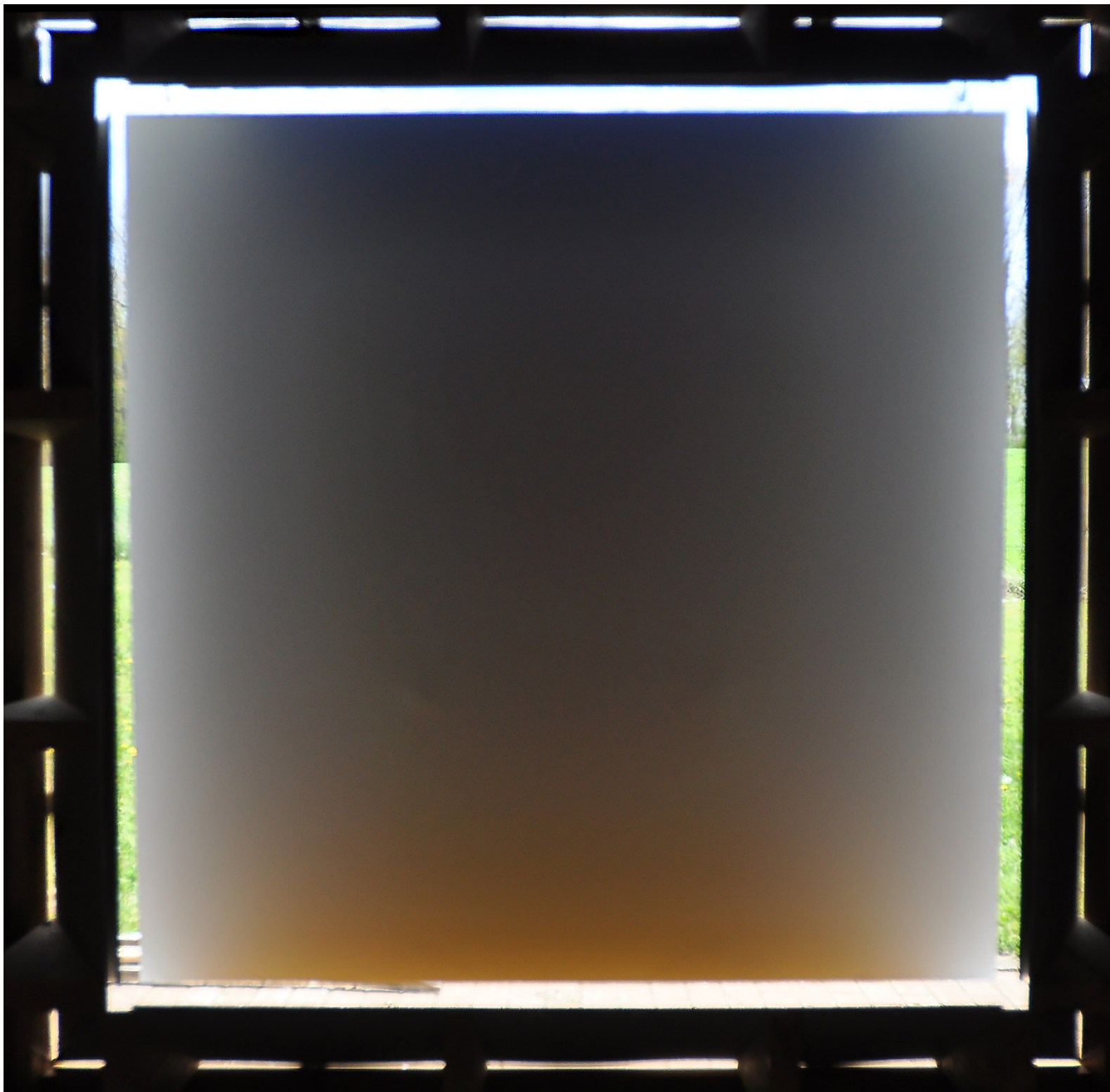

05/02/2014, Morning
Blue over Yellow

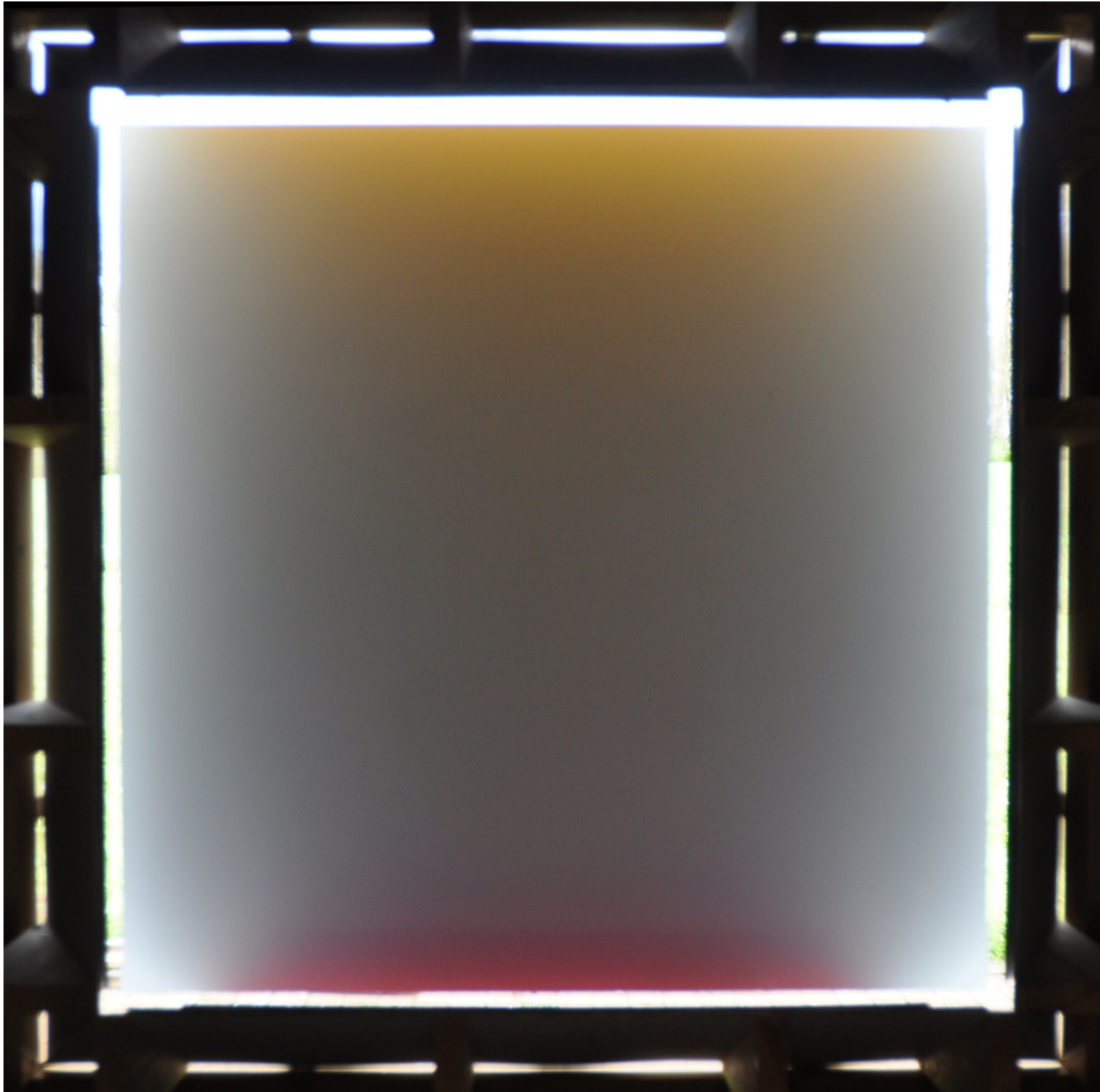

05/01/2014, Afternoon
Yellow over Red and Blue
First Arrangement

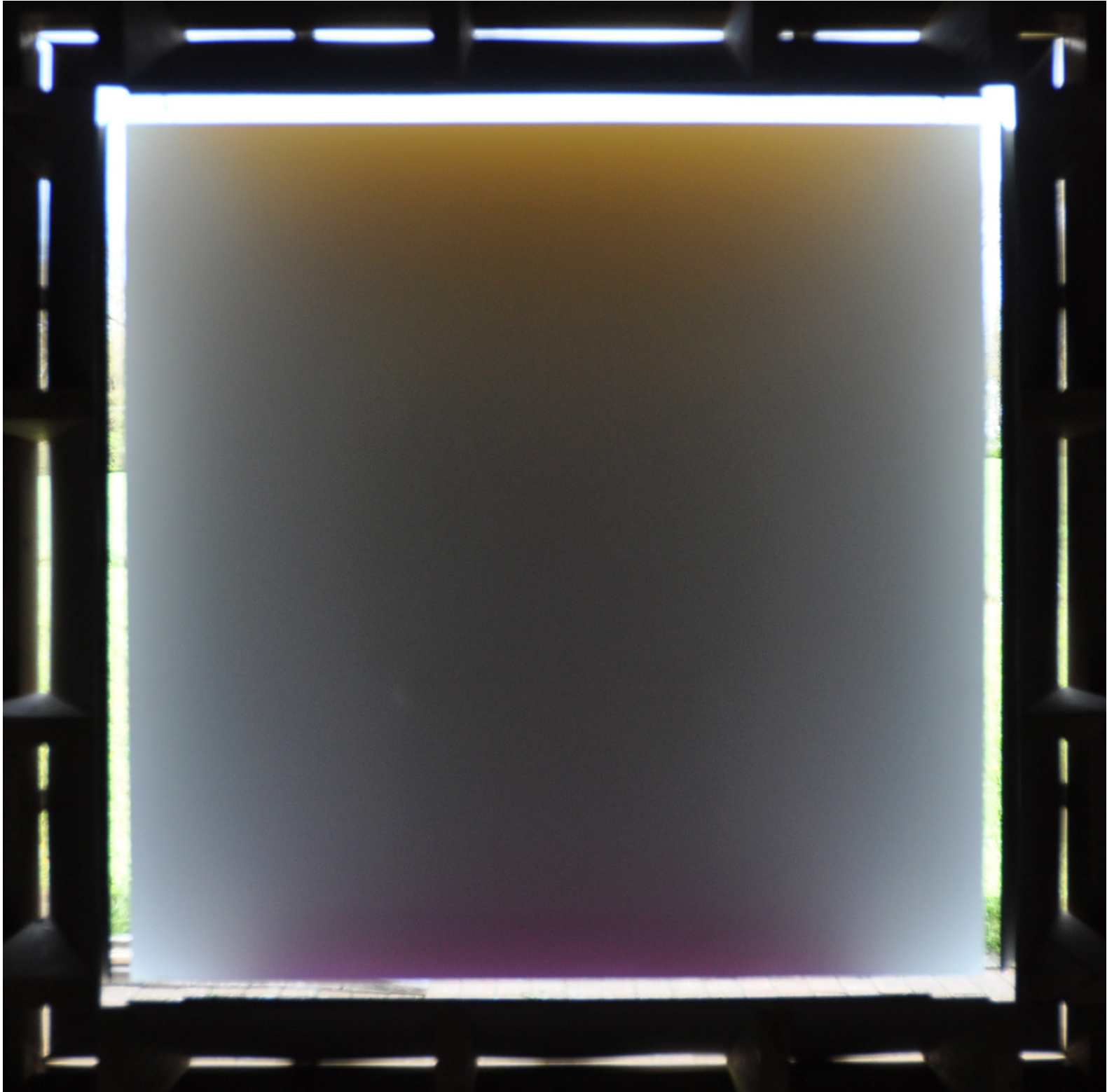

05/01/2014, Afternoon
Yellow over Red and Blue
Second Arrangement

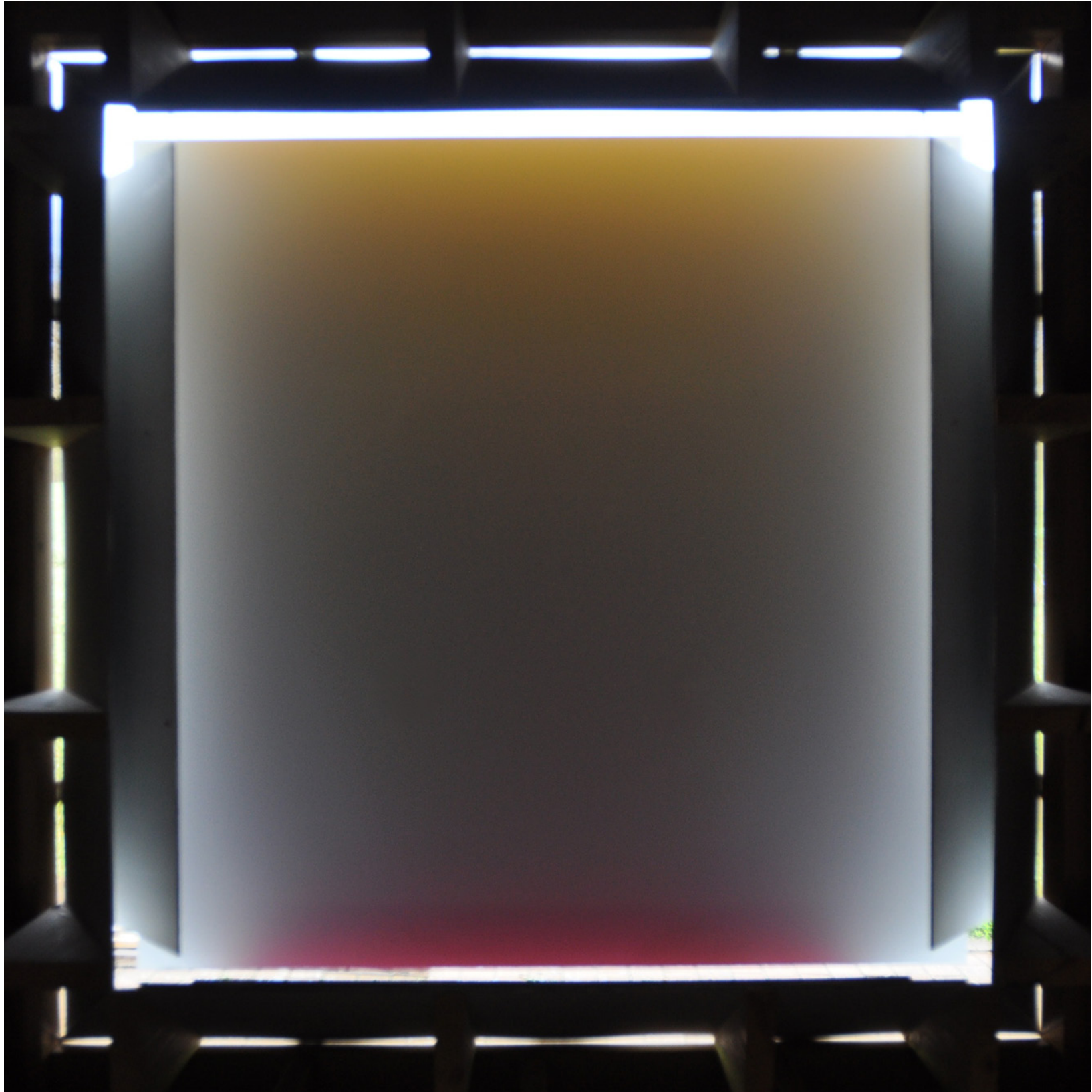

05/01/2014, Afternoon
Yellow over Red and Blue
First Arrangement
Left and right reflectors closed

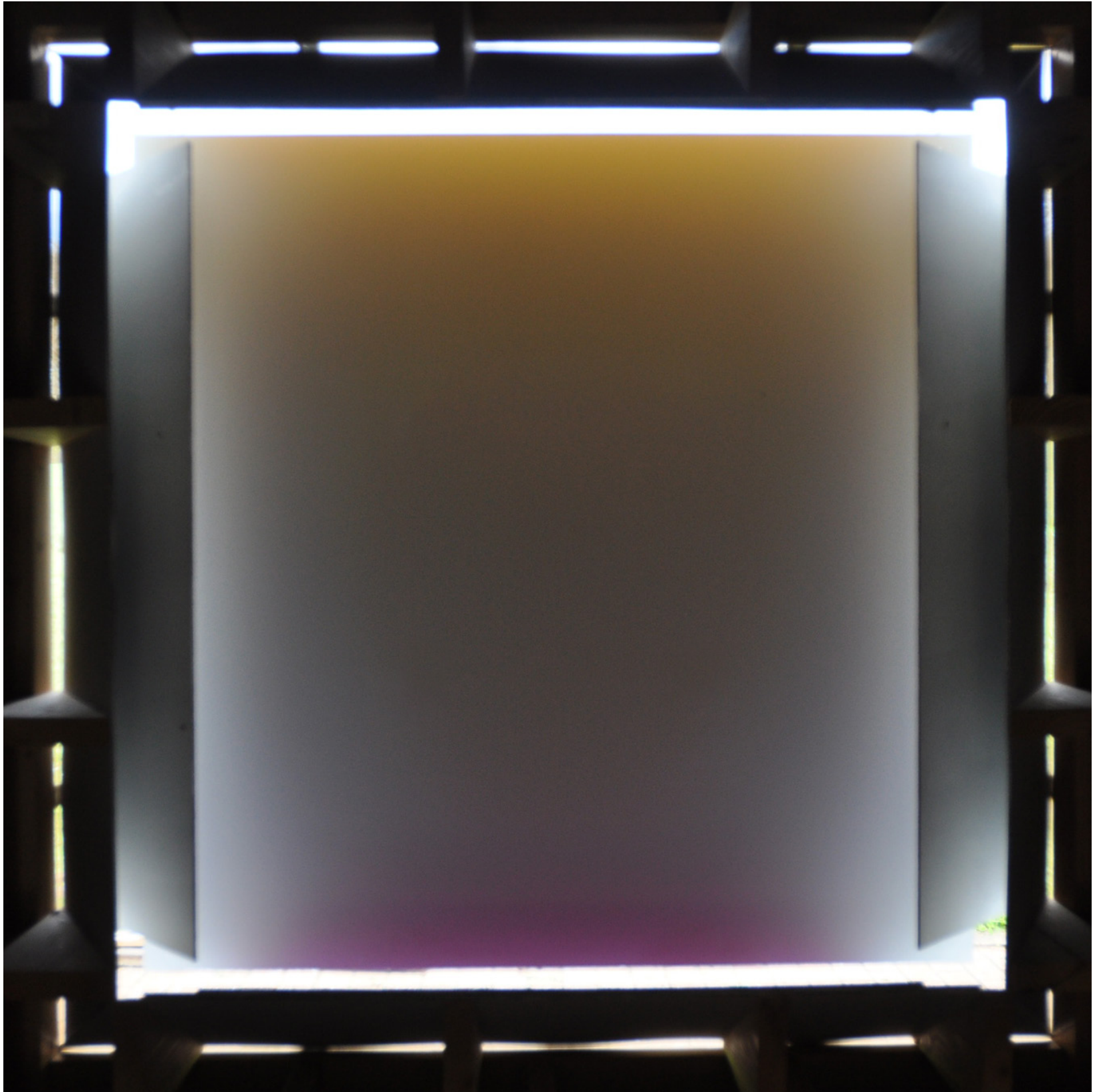

05/01/2014, Afternoon
Yellow over Red and Blue
Second Arrangement
Left and right reflectors closed

FINDINGS:

I: Color Atmospheres

After these studies of a room containing a chromatic oculus, a few things became clear. The first was that one color seemed to dominate the space, both in the first and second models. In the second model, the colored surface that the observer sees directly was always a stronger visual element than the indirect colored reflection. What also became clear was the relative nature of the surfaces and reflections, that their appearance and perception would be dramatically different in changing light and atmospheric conditions.

II: A Way to Study Color

Through studying color at a larger scale, at the scale of the room, the observations made in the first studies became even more apparent. What also became clear was a distinction between this sort of work and Josef Albers' experiments with color. In Albers' work, the lighting was assumed to be constant, with the color juxtapositions and arrangements to be variable. In this sort of experiment, the color arrangement was held constant with the lighting condition being variable. In these changing reflective light environments, the perception of a surface, whether painted a color or white, was dramatically different at different times of the day. When I began to look closely at the surfaces, at color mixtures for example, there was a certain power in the images. I felt a strong emotional response to these compositions, and I thought it merited further exploration.

III: A Room of Color

I discovered something about the power of color, about its innate ability to affect one's emotions and psyche. There was an incredible energy in every composition, though each had a very distinct reading. Goethe writes in his *Theory of Colors* that "all of nature reveals itself by means of colors to the sense of sight." In this way our sense of sight is a perception of energy, of light energy. In this study, I discovered that through the application of color, it was possible as an architect to impact the perception of a room through the interaction of material and light.

IV: A RETURN TO THE ROOM

At a certain point, the studies began to suggest an architecture. It was an architecture of light and of color, light's phenomenon. The following is a series of architectural dreams, dreams of spaces which possess and gather light phenomena.

It is a series of meetings: the meeting of a wall and a floor, the meeting of a wall and a ceiling, the meeting of a ceiling and the sky. It is an architecture which celebrates these meetings with the gathering of light.



04/23/2014, 8:00 p.m.

The meeting of the wall and the floor
First Light Condition



04/23/2014, 8:00 p.m.

The meeting of the wall and the floor
Second Light Condition



04/23/2014, 8:00 p.m.

An idea of a wall
First Arrangement



05/29/2014, 4:30 p.m.

An idea of a wall
Second Arrangement



05/27/2014, 5:30 p.m.

The meeting of the wall and the floor
First Light Condition



05/29/2014, 4:30 p.m.

The meeting of the wall and the floor
Second Light Condition

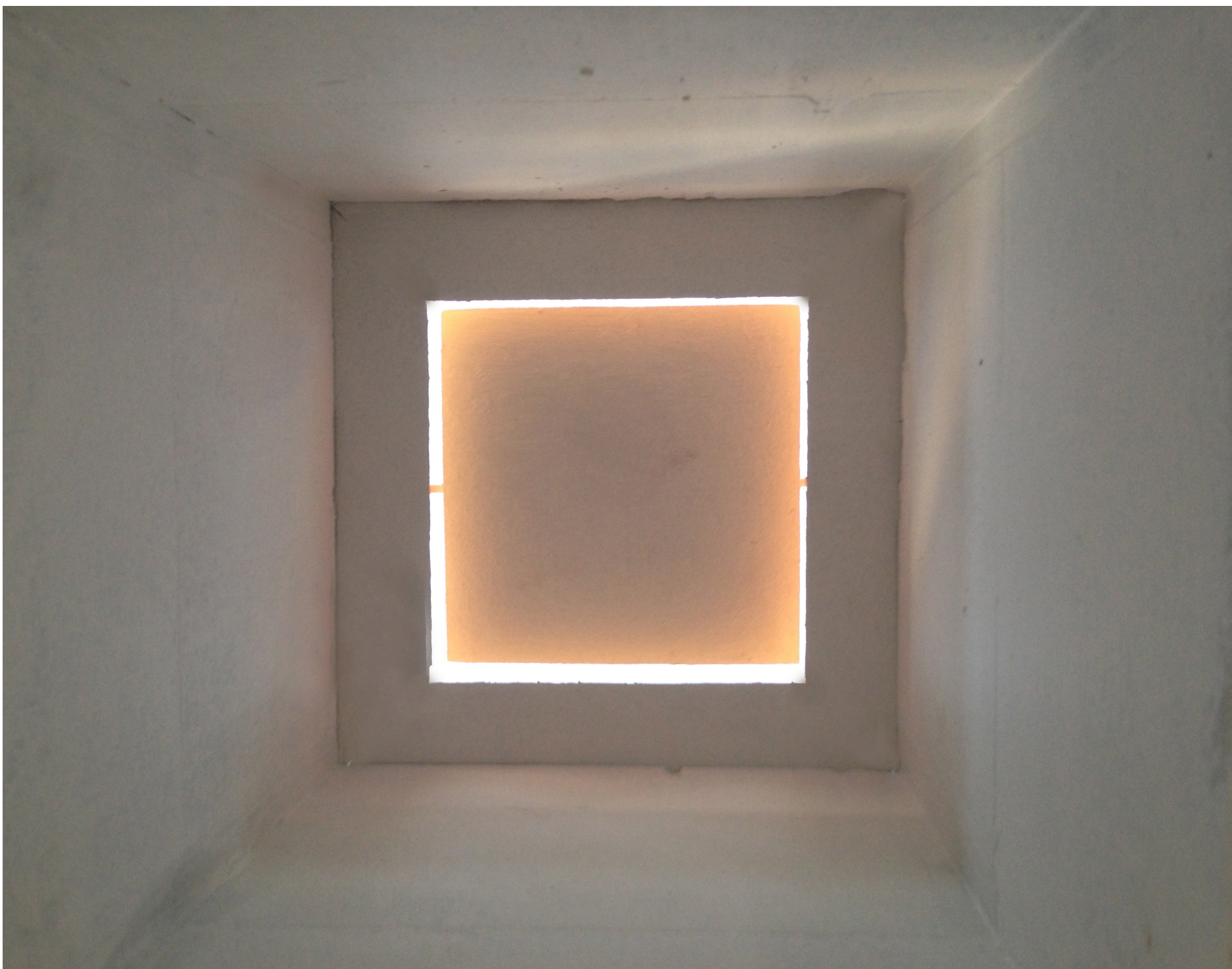

05/28/2014, 8:15 p.m.

An idea of a ceiling
First Arrangement

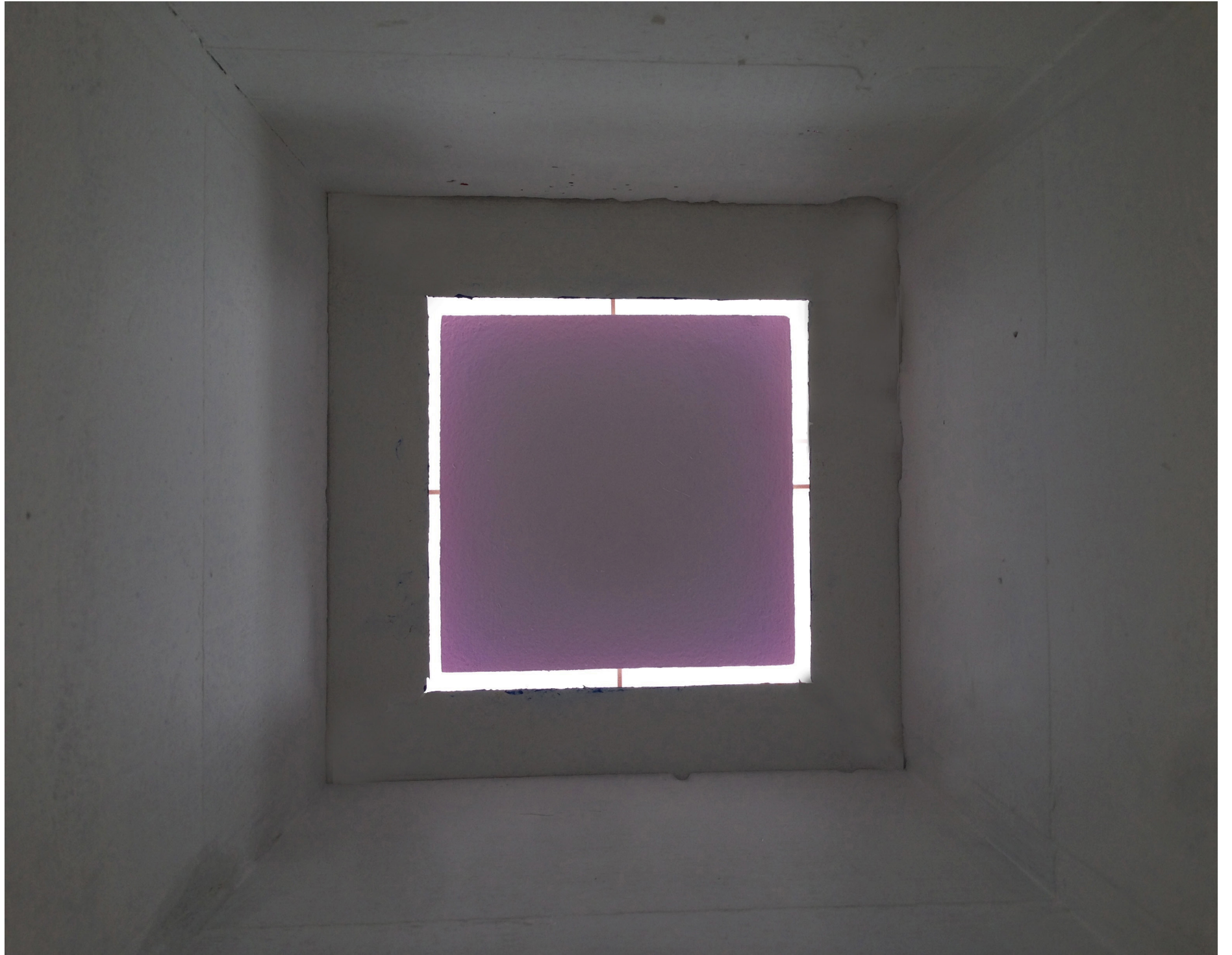

05/29/2014, 4:30 p.m.

An idea of a ceiling
Second Arrangement

Conclusions:

By returning to the room it became clear that the common search through every study was the search for an architecture of light. It was a specific light, a slow kind of light, and this light carried with it the color of its environment and its architecture. In viewing color gained through light reflection, one begins to perceive the nature of a pure phenomenon. Goethe writes in his *Theory of Colors* that “the observer does not see the pure phenomenon with his eyes, but more with his soul.” These spaces speak more to one’s soul than to one’s intellect. This is the architecture that I am interested in, one that arises from feeling and emotion rather than from calculation and reason. Le Corbusier writes in *Towards a New Architecture*, “Architecture is the masterly, correct, and magnificent play of masses brought together in light. Our eyes are made to see forms in light; light and shade reveal these forms.” In my own studies I have found that when light is brought into maximum darkness it finds its true expression. In this aspect and with its aspect of color, light extends beyond our eyes and beyond time into what connects us with light from the sun and the light from stars millions of light years away.

METHODS

The following is a description of the methods used to achieve the results presented in the previous studies. All of these studies involved the making of things: the making of objects, the making of rooms.

Often the challenge of each study was understanding the way light interacts with material to yield color. Each model, each aperture, each room was designed to be flexible and dynamic in order to have the ability to change things and make aesthetic judgements regarding the light reflection produced.

Just as each result was recorded through a camera, through a photograph, each of these objects is itself a camera, in the sense that each is a room. Each aperture was modifiable, in order to produce a desired effect, in order to make a record of light.

COLOR ATMOSPHERES

Study Models



The first model of the color atmosphere study was a wax model with an open wall, designed to be viewed as a section of a room. The light effects were to be observed indirectly, only observable on the walls of the chapel. Immediately this seemed to be a limiting factor of the design, and further investigation was necessary.

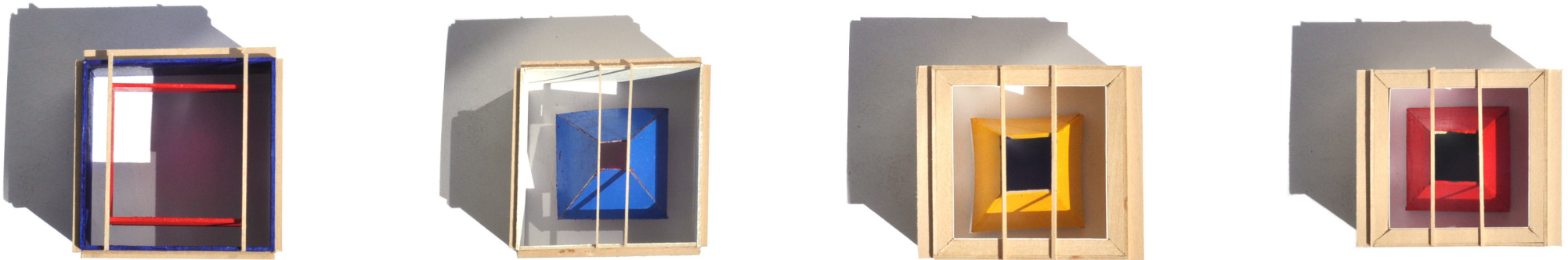

First group of study models of the chromatic oculus.

The design shifted from a series of nested rectangles to a truncated pyramid suspended within a rectangular frame.

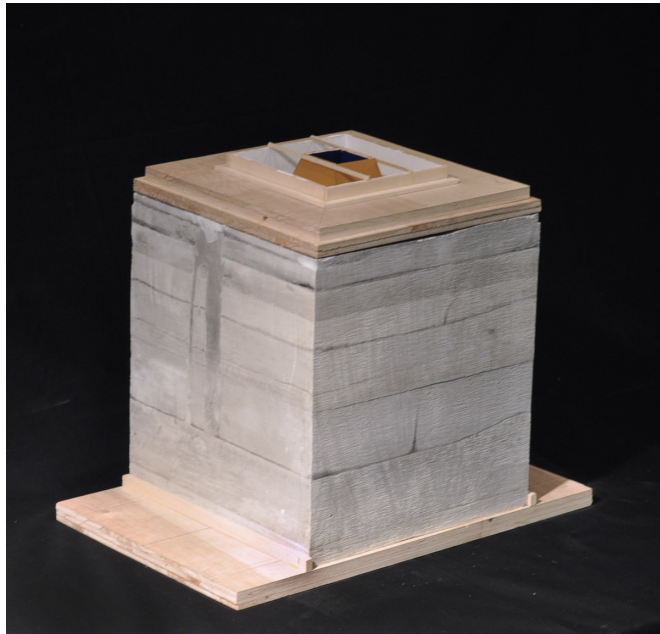

In the second chapel model, the idea was to look up at the chromatic occulus, to imagine being inside of this sort of space. Building on the research from the first model, each occulus was designed as a primary color opposition, with one color being viewed directly while the other color being observed only through its reflection.

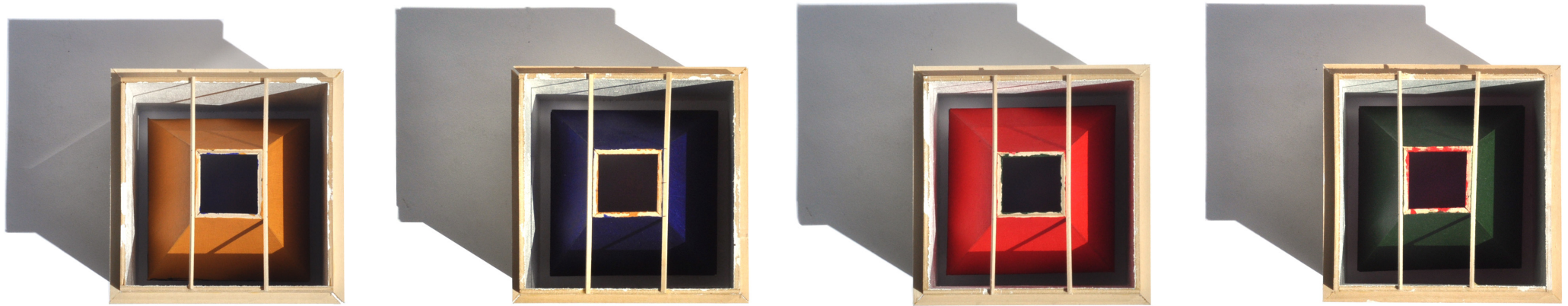

Second group of study models of the chromatic occulus.

Paints used: Yellow Ochre, Ultramarine Blue, Cadmium Red, Chromium Oxide Green

TEST CELL: FIRST ITERATION

Installation Drawings

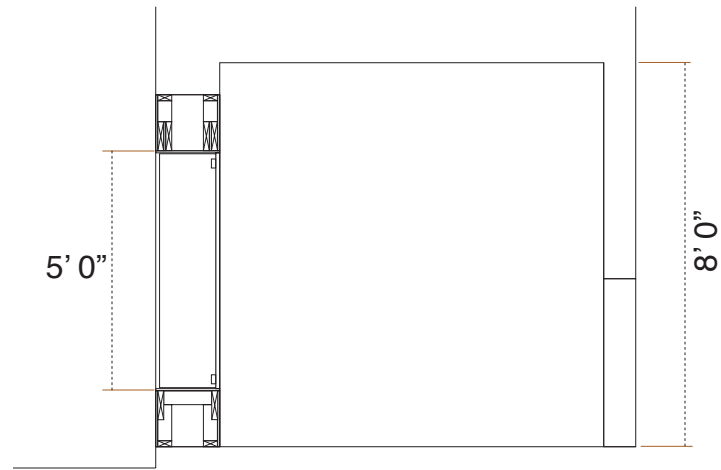

Installation section

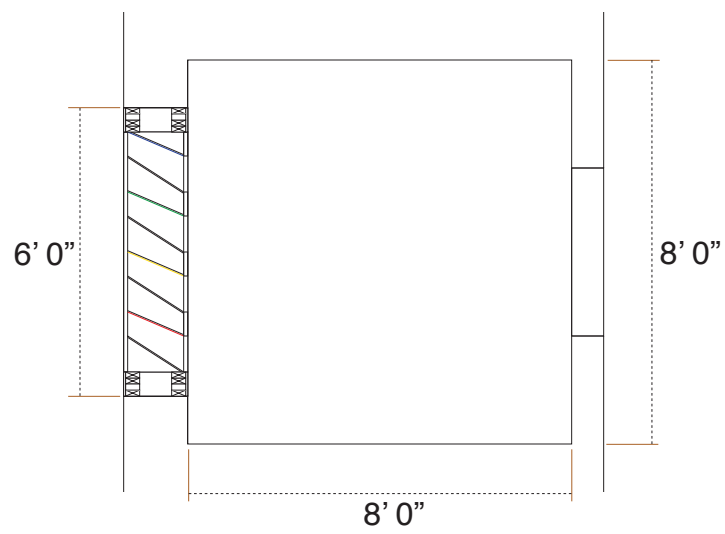

Installation plan

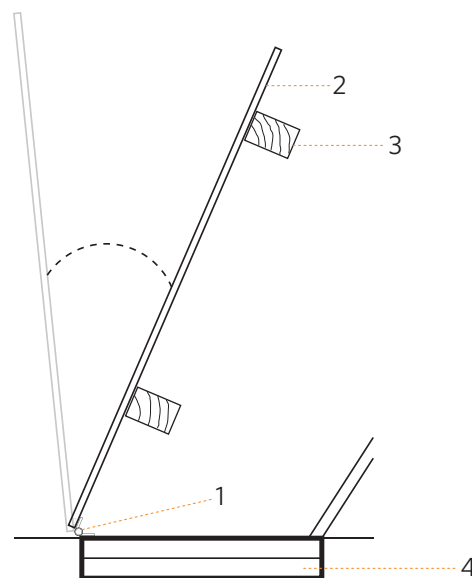
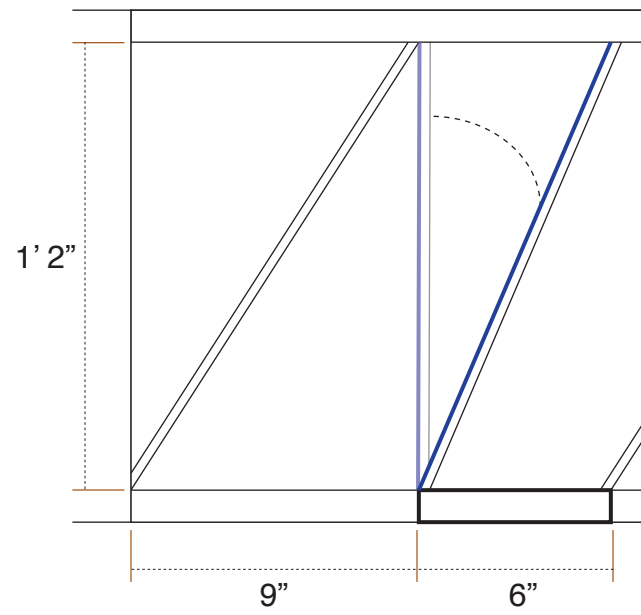

Hinge Panel Detail

- 1: 2"x1/2" Stainless Steel Hinge
- 2: 14"x60" Painted Masonite Panel
- 3: 1"x1.5" Pine Stiffening Member
- 4: 1/2" Plywood

TEST CELL: FIRST ITERATION

Exterior

Reflecting panels hinging from open to closed



Open position



Hinging closed: 4" opening

Interior

Effects of hinging panels closing on color intensity



Open position



Hinging closed: 4" opening



Hinging closed: 2" opening



Closed position



Hinging closed: 2" opening



Closed position

TEST CELL: SECOND ITERATION

Installation Drawings

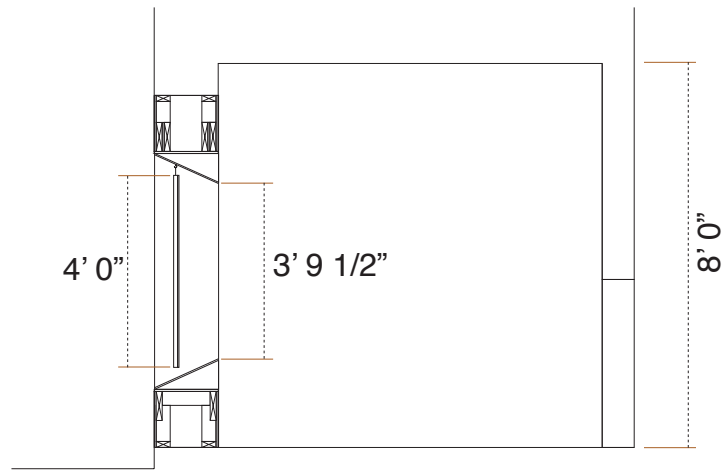

Installation section

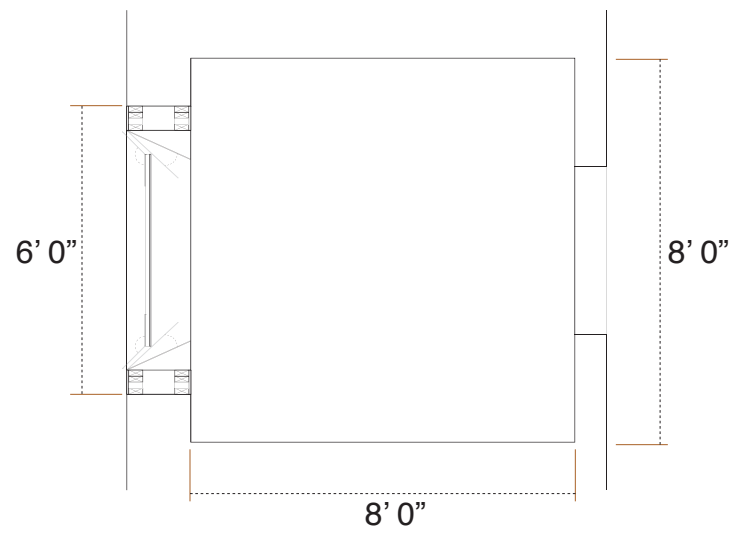

Installation plan

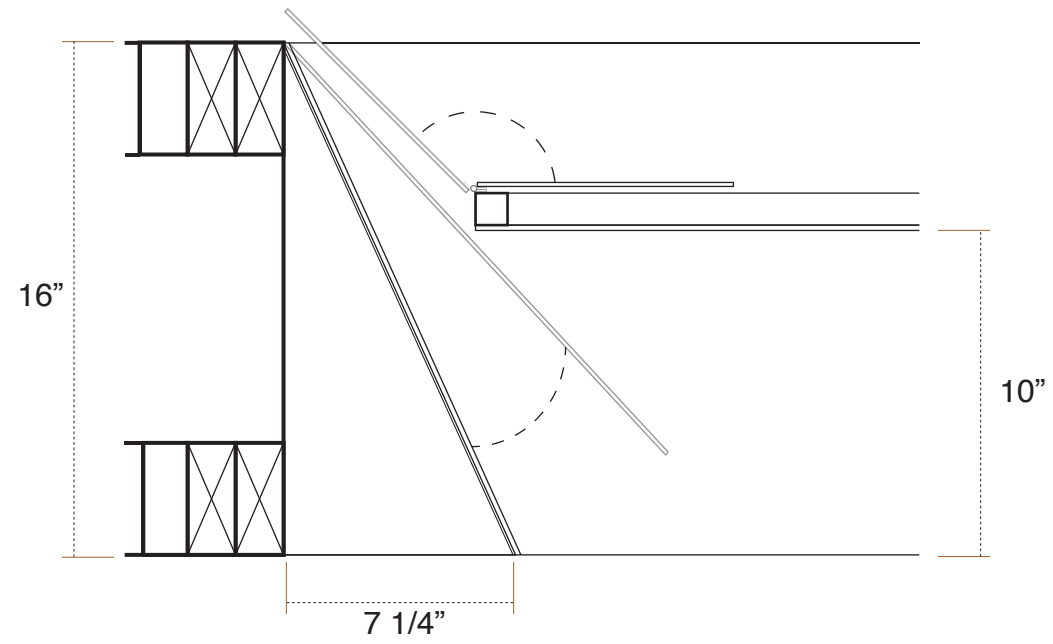

Apparatus Detail

- 1: 1"x1" Pine Stiffening Member
- 2: 1/2"x2" Stainless Steel Hinge
- 3: 8"x4'x3/16" Mitered Masonite Panel
- 4: 4'x4'x3/16" Masonite Panel

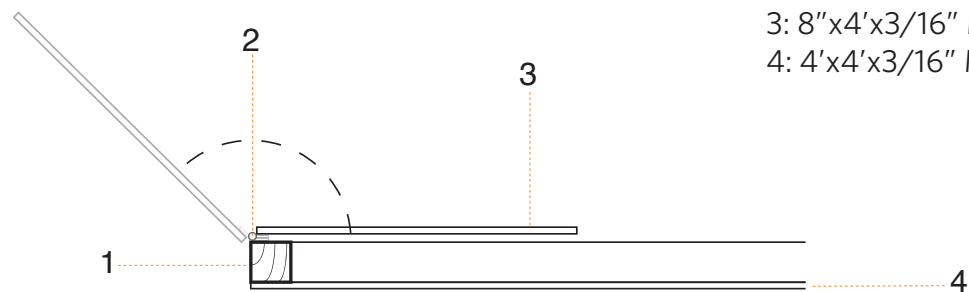

TEST CELL: SECOND ITERATION

Exterior:

Light reflectors hinging from closed to open



Light reflectors in closed position



Left and right reflectors hinging outwards

Interior:

Light reflectors hinging from open to closed



Apparatus in open position

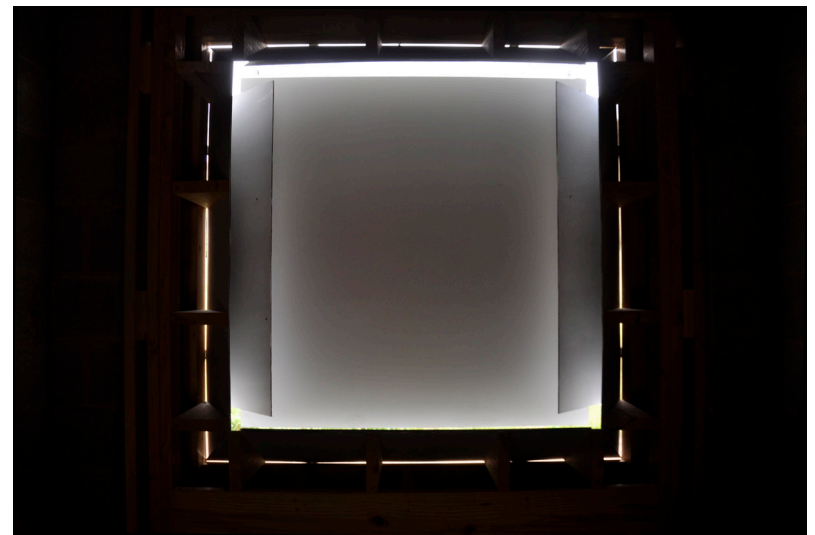

Left and right light reflectors fully closed



Light reflectors at 90 degrees



Light reflectors fully open



Top and bottom light reflectors fully closed

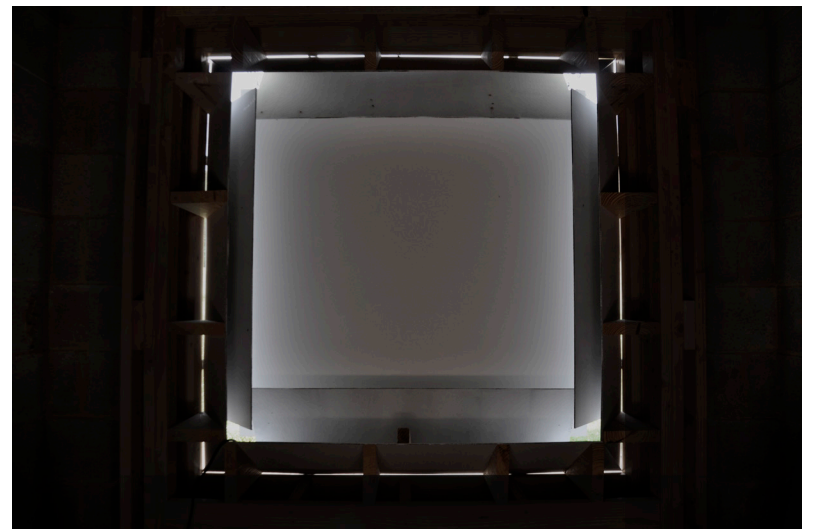

All light reflectors in closed position

RETURN TO THE ROOM:

Photographic Methods

These models were made primarily to show an interior space that would have a certain quality of light.

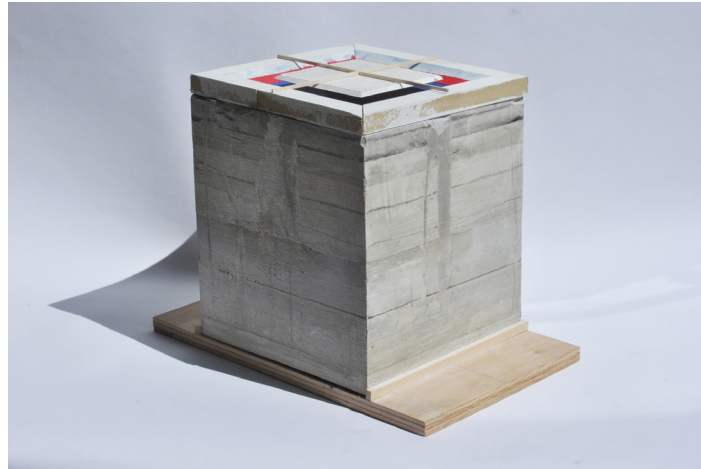

Ceiling model with second color arrangement

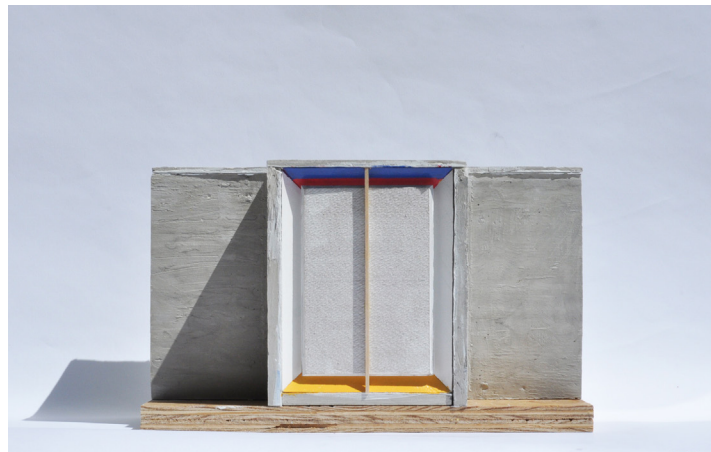

Wall model with second color arrangement.

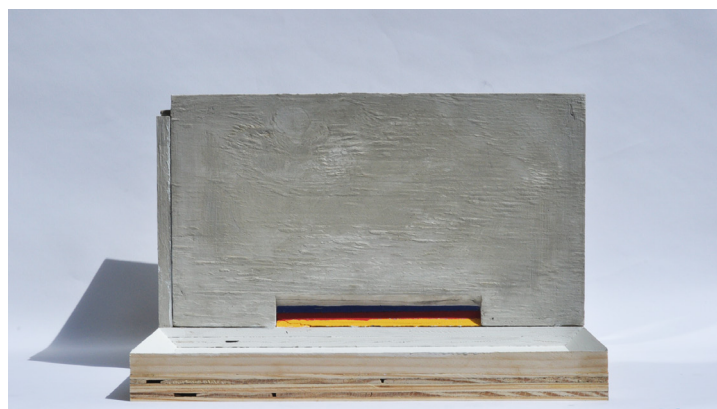

Wall/Floor model with first color arrangement.

In order to photograph these interior conditions, it was necessary to place the model in its proper orientation to the sun and to block all excess light with a black cloth if needed.



Ceiling model: Photographs of the interior were taken from below looking towards the sky.



Wall Model: Photographs were taken looking northwest with a black cloth blocking light from any other direction.



Wall/Floor Model: Photographs were taken with the light coming from the west with a black cloth blocking light from any other direction.

SOURCES

Albers, Josef. *Interaction of Color*. New Haven: Yale University Press, 1963.

Albers, Josef and Nicholas Fox Weber. *Josef Albers: A Retrospective*. New York: Solomon R. Guggenheim Foundation: H.N. Abrams, 1988.

Goethe, Johann Wolfgang von. *Theory of Colors*. Ed. Rupprecht Matthaei. Trans. Herb Aach. New York: Van Nostrand Reinhold, 1971.

Heer, Jan de. *The Architectonic Colour : Polychromy in the Purist Architecture of Le Corbusier*. Trans. George Hall. Rotterdam: 010 Publishers, 2009.

Holl, Steven. *Parallax*. New York: Princeton Architectural Press, 2000.

Kahn, Louis and Robert C. Twombly. *Louis Kahn: Essential Texts*. New York: W. W. Norton, 2003.

Katz, Vincent, ed. *Black Mountain College: Experiment in Art*. Cambridge: MIT Press, 2013.

Rothko, Mark and Diane Waldman. *Mark Rothko: A Retrospective*. New York: Solomon R. Guggenheim Foundation: H.N. Abrams, 1978.

Vinciarelli, Laretta. *Not Architecture But Evidence That It Exists*. New York: Princeton Architectural Press, 1998

Tanazaki, Jun'ichiro. *In Praise of Shadows*. Trans. Thomas Harper and Edward Seidensticker. Stony Creek: Leete's Island Books, 1977.

Turrell, James. *The Thingness of Light*. Ed. Scott Poole. Blacksburg: Architecture Edition, 2000.

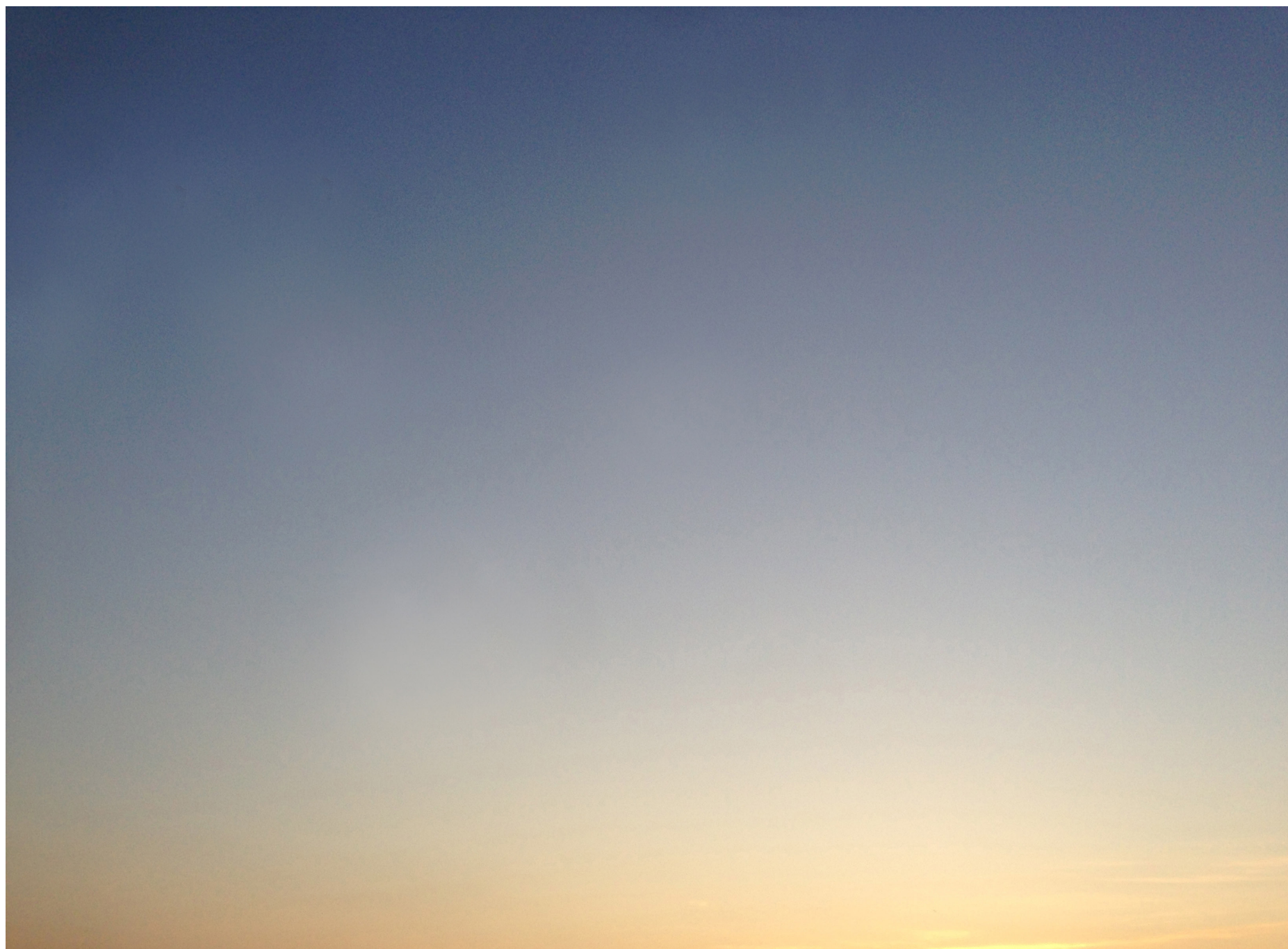

07/06/2014, 8:35 p.m.

The Sky at RDF

LIST OF IMAGES

- 1: Second Color Atmosphere Model
- 3: Color Atmosphere Group 1: Nested
- 5: Color Atmosphere Group 1: Inverted
- 7: Color Atmosphere Group 2: Snow
- 9: Color Atmosphere Group 2: Sun
- 10: First Color Reflection Spectrum
- 12-13: Color Swatches
- 14: RDF Site Images
- 16: Construction of the Opening Images
- 17: Light Reflector Installation Images
- 18-19: Test Cell Interior Images
- 21: Receiving Surfaces Direct Sunlight
- 23: Receiving Surfaces Indirect Sunlight
- 25: Four Reds
- 26: Blue in Four Contexts
- 27: Yellow in Four Contexts
- 28: Red in Four Contexts
- 29: Green in Four Contexts
- 31: Intensification of Red
- 33: Color Mixture: Red, Yellow, and Blue
- 34: Construction of Second Apparatus
- 37: Light Apparatus First Installation
- 38-39: Effects of Positioning/Proximity
- 40: First Color Arrangement: Room
- 42: Yellow over Yellow
- 43: Blue over Blue
- 44: Yellow over Blue
- 45: Blue over Yellow
- 46: Yellow over Red and Blue: First Arrangement
- 47: Yellow over Red and Blue: Second Arrangement
- 48: Yellow over Red and Blue: First Rectangle
- 49: Yellow over Red and Blue: Second Rectangle
- 54: Floor: First Light Condition
- 55: Floor: Second Light Condition
- 56: Wall: First Arrangement
- 57: Wall: Second Arrangement
- 58: Floor Reverse: First Light Condition
- 59: Floor Reverse: Second Light Condition
- 60: Ceiling: First Arrangement
- 61: Ceiling: Second Arrangement
- 66-67: Color Atmosphere Studies
- 68-69: First Test Cell Drawings
- 70-71: First Test Cell Interior/Exterior
- 72-73: Second Test Cell Drawings
- 74-75: Second Test Cell Interior/Exterior
- 76: Room Models
- 77: Room Models Photographic Methods
- 79: Sky at RDF

All images created by and owned by the author.