

meetings

by

uwe nienstedt

thesis submitted to the faculty of the
virginia polytechnic institute and state university
in partial fulfillment of the requirements for
the degree of

master of

Architecture

approved :

olivio ferrari
chairman

william w. brown

d. eugene egger

ellen b. braaten

september , 1987
blacksburg , virginia





meetings

by

uwe nienstedt

(abstract)

the thesis consists of two parts :

the introduction states a rationale for the making of Architecture by defining its final and subsidiary goals and identifying the importance of 'judgement' and the concept of 'order' as operational means.

the project attempts to apply the theory on three different scales: object, building and urban. this part of the book is structured around the theme of 'meetings', the enjoyment of two entities coming together and in various ways interacting and redefining each other architecturally.

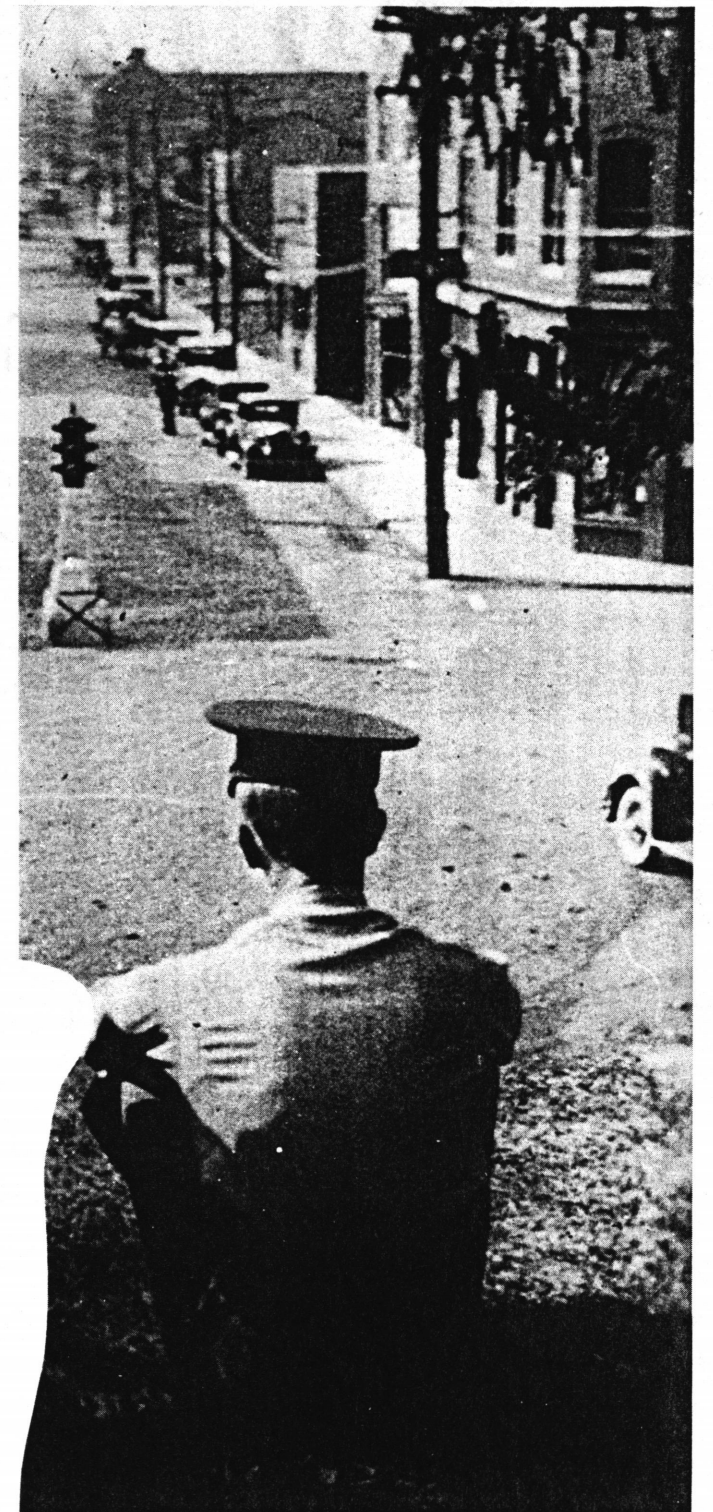

dedication

to olivio and hjördis
whose standards this book has to face

to hans and gerard
who kept pushing me to my limits

to Architecture

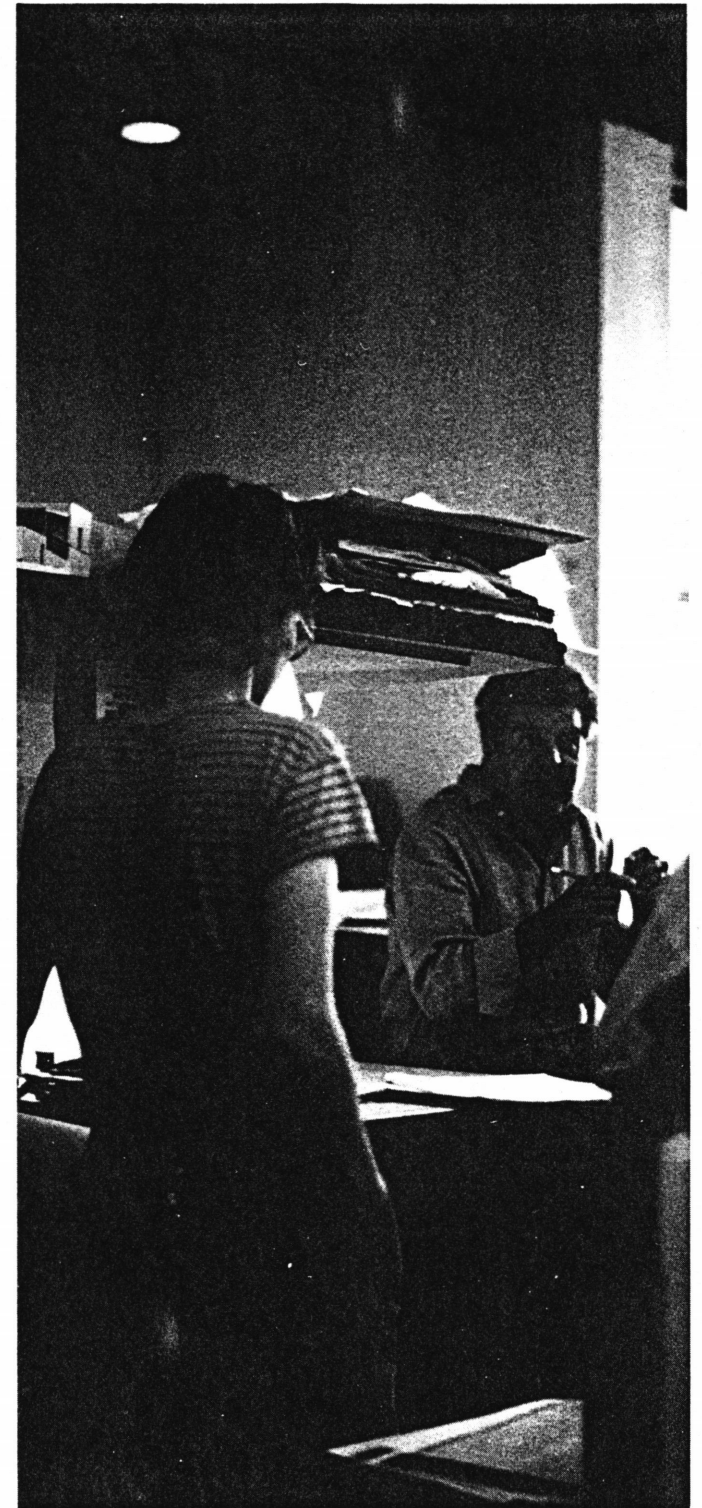

3 line meets circle

a tea service

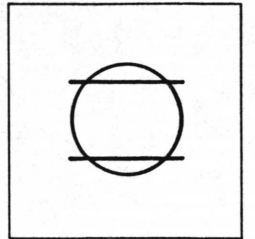

7 public meets private

housing in a town center

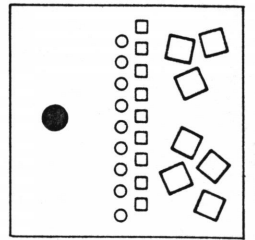

14 town meets university

two places

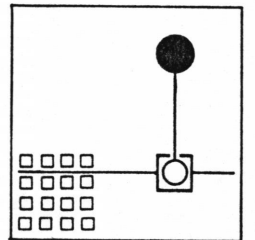

21 mall meets mainstreet

terminating axes

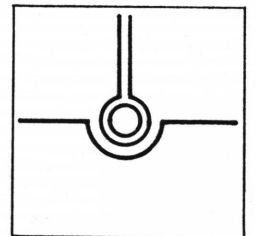

a statement

*why Architecture ?
because it is...¹*

louis i. kahn

Architecture is an expression of the dignity and culture of men. as a field of inquiry it has its own subsidiary ends, which in turn serve the higher ends of man's being on earth. Architecture exists and, in form of buildings and drawings, becomes present. the architect's purpose is to translate this intangible existence of architecture and, by his actions, give it its tangible presence.

to make this understood i have to back up to the primary questions:

what is the purpose of men's actions? what is our end in the world ?

aristotle says:

every art and every inquiry ...aims at some good;for this reason the good has rightly been declared to be that at which all things aim. now, as there are many actions, arts, and sciences, their ends are also many. ...in all of these the ends of the master arts are to be preferred to all the subordinate ends.

if then, there is some end to the things we do,which we desire for its own sake (everything else being desired for the sake of this) and not for the sake of something else, clearly this must be the good and the chief good...

[the good] seems different in different actions and arts.what then is the good of each? surely that for whose sake everything else is done. evidently this chief good is something final, and if there is more than one, the most final of these will be what we are seeking.²

aristotle distinguishes between the final and subsidiary goods. to him the highest good is the contemplation of truth, knowledge of which for him is the greatest contribution to the flourishing of man.

Architecture, as all arts, must transcend its subsidiary ends by informing its own activities with direct expression of the final good itself. good Architecture, built or drawn, conveys that 'intelligent' (from greek, meaning 'to bring in the end') judgement has been made to bring out those final and subsidiary goods. in my judgement all good Architecture has one thing in common. it conveys order.

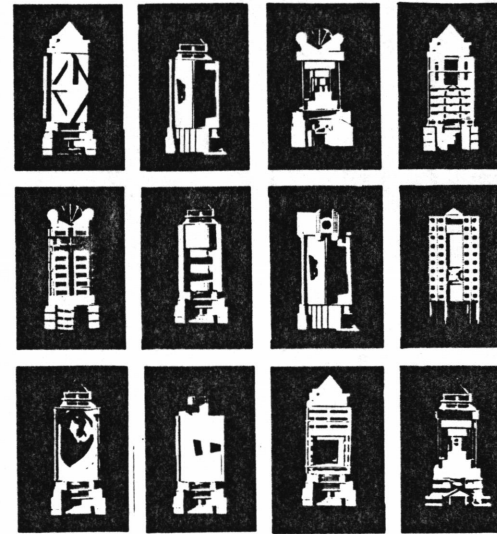

order

'the term 'order' by itself is vague. the question has to be 'to order what to what end?' not order on the lowest level,like an orderly shelf, but order as an aesthetic event. what distinguishes men from animals is the ability to choose [aristotle] , to use judgement to make conscious decisions.

le corbusier says :

placed in the midst of chaotic nature, man for his own security creates and surrounds himself with a zone of protection in harmony with what he is and what he thinks; he needs things whose existence he has himself determined.

the things he makes for himself are a creation which contrasts all the more with his natural surroundings because its aim is closer to his mind, and further away and more detached from his body. we can say that the further human creations are from our immediate grasp, the more they tend to pure geometry; a violin or a chair, things which come into close contact with the body, are of less pure geometry; but a town is pure geometry. it is then that he achieves what we call order.³

to me, the subsidiary goal is, in broad terms, to structure the environment in order to create places for man and the flourishing of his institutions (learning, praying, dwelling). men gave one place a different significance than another, using building to create hierarchies which express cultural achievement. Architecture became and was a means to celebrate men and culture, with the city being its highest expression.

although these goals are not 'final' in the aristotelian sense, they are deeply rooted in the evolution of man and not easily changeable. it is only on the next lower level in the hierarchy of 'goods' that the subsidiary goals can be manipulated somewhat freely according to choice.

in compliance with this hierarchy man created order...

...and seems to lose it again.

looking at most of the recent developments in Architecture it seems that order is not an issue anymore; placelessness prevails and pragmatism rules. Architecture is in danger of decaying into 'shelter', stripped of all meaning and void of cultural significance. a reason for that is the preoccupation with superficial images, pleasure for the 'senses', substituting 'style' for 'substance'.

architects have the responsibility to counter this development by understanding the significance that Architecture has and by bringing it into presence by 'making'. in writing about art, aristotle distinguishes *making*, which he defines as '*producing under the guidance of true reason*', from *acting*, which for him is the world of everyday problem solving. he believes that art (and Architecture) belongs in the realm of the 'coming-to-be', the bringing into 'existence', the 'making', and is not connected to *utility* ⁴.

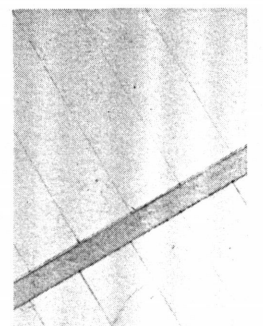

judgement

none of the above is operational to create Architecture. it can form an attitude and help to find a rationale that can then be put to use. Architecture as a phenomenon is not up for grasps. if it exists but has to be transcended into drawings or buildings to have presence, we have to employ the right means to do so.

i believe that there are two fixed points that are indispensable in the making of Architecture :

1. architectural ends and a final end do exist. we have to be dedicated and committed to the search for truth, one that cannot be confirmed by empiricism. these lie in the realm of the intangible existence of Architecture.

when louis i. kahn says "*form precedes design*"⁵ (form being the essence of a thing and design being its manifestation) he means that you can not tamper with the 'essence', but that the task of the artist is to bring out the indefinite variety of presences produced from the concerns of these 'absolutes'.

2. architectural judgement is indispensable.

- making order
this is the world of ideals, the world of the history and the biased personality of the architect, his knowledge and experience.
what is it i want to deal with?
- finding order
this is the world of facts, where the analysis of the project and its various parameters bring out the understanding of what the task is all about.
what is the essence of the project?

i believe that operating within this framework, using true reasoning in keeping in touch with one's ideals and goals can yield 'good' Architecture.

i have to clarify here what i mean by 'truth'; not the so called 'scientific objective truth' (which i do not believe exists) but the supported (by analysis), educated (by experience), intelligent (bringing in the *end*) judgement of what Architecture should always be in order to arrive at a level of knowledge of what can make good Architecture.

therefore the architect has to be a faithful traveller, driven by the quest for truth and by the desire to live up to the intangible.

"...our work is merely a journey, there are no diversions, no shortcuts..."⁶
aldo rossi, architect

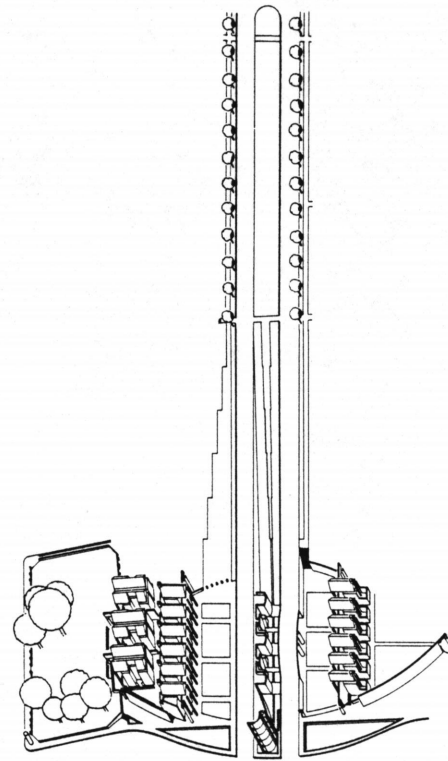

a project

the work in the book was produced during the development of my beliefs as stated in the previous section. both the theory and the project should be seen as an attempt to formalize a position in Architecture at the still-point between the end of a career as a student and the beginning of a career in the profession. the endeavor of learning, however, is lifelong and this book is only a work report at a random point in time. however finished as a product the book and the project appears to be, as a vehicle for learning it is only abandoned.

a prerequisite for my thesis was the desire to make a statement on a wide variety of scales, in this case on a joint, an architectural object, a building, an urban block and a town.

i choose to organize this book around the theme of 'meetings', the enjoyment of two things coming together and in various ways interacting and redefining each other. it is this moment of change, when two things meet, that clarifies what the nature of both entities are. it is the celebration of this event that this thesis is all about.

the book is divided in four parts, four 'meetings':

1. line meets circle (a teapot)
 - clay/metal
the joining of two distinctly different materials
 - tension/compression
a joint resolving a structural problem
2. public meets private (housing in a town center)
 - archetype/context
the search for 'type' and its application
3. town meets university (two places)
 - informal/formal
a formal entrance for the university and an informal contribution to the town
4. mall meets mainstreet (terminating two axes)
 - termination/continuation
a place of endings and beginnings
 - permanent/temporary
signifying the importance of the site on a symbolic, a physical, and a utilitarian level

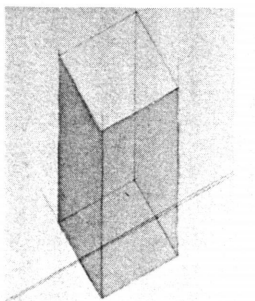

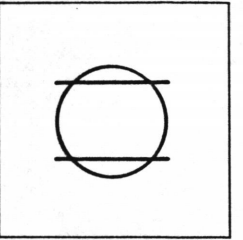

line meets circle

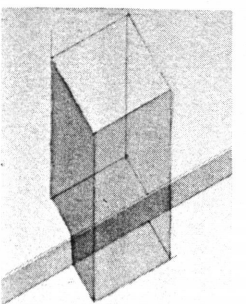

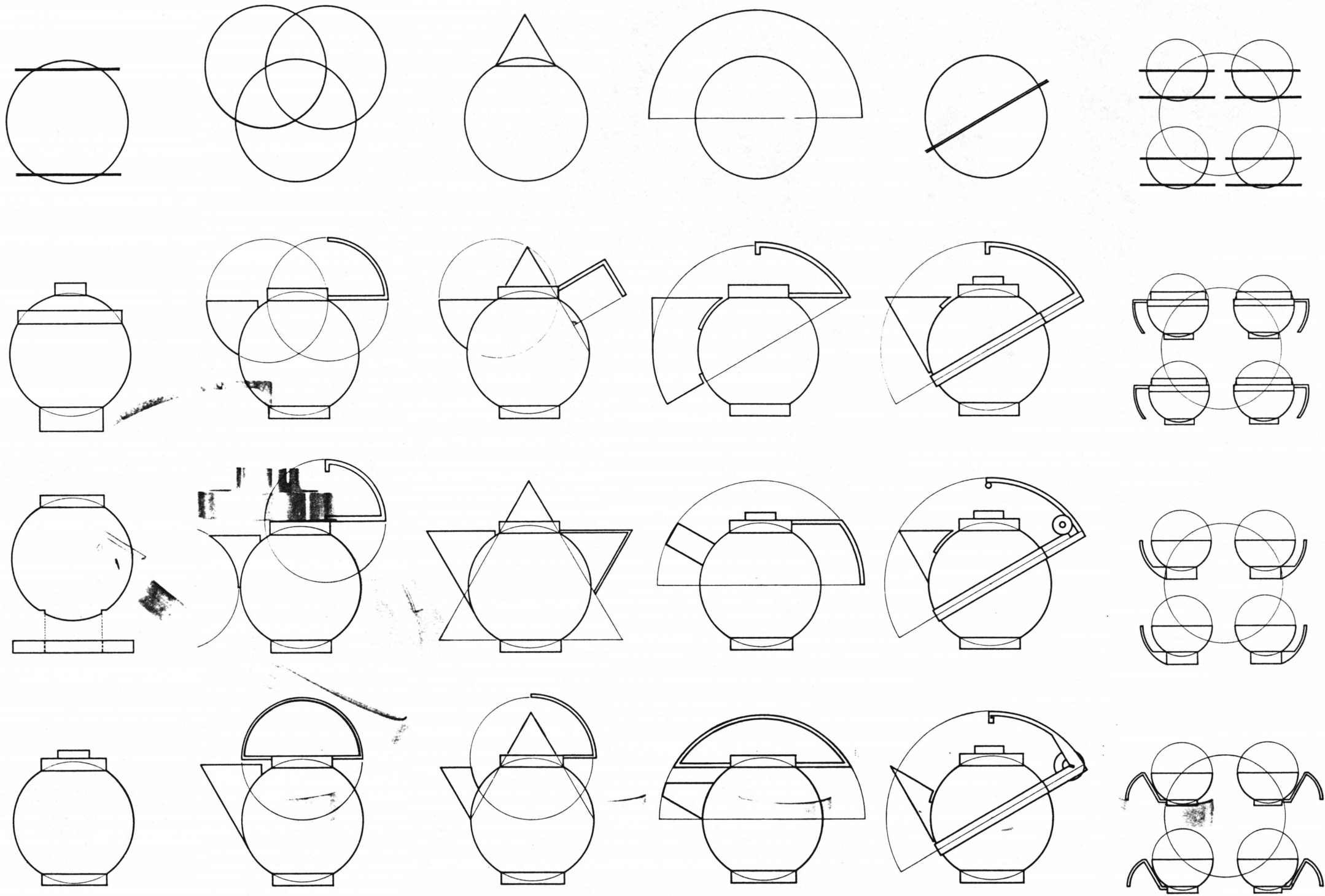

it is the moment of change, when two entities meet,
 that makes aware the beauty of both
 and allows for the making of rules

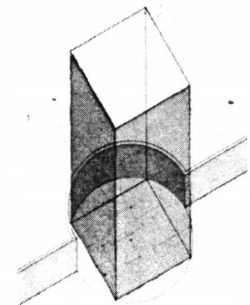

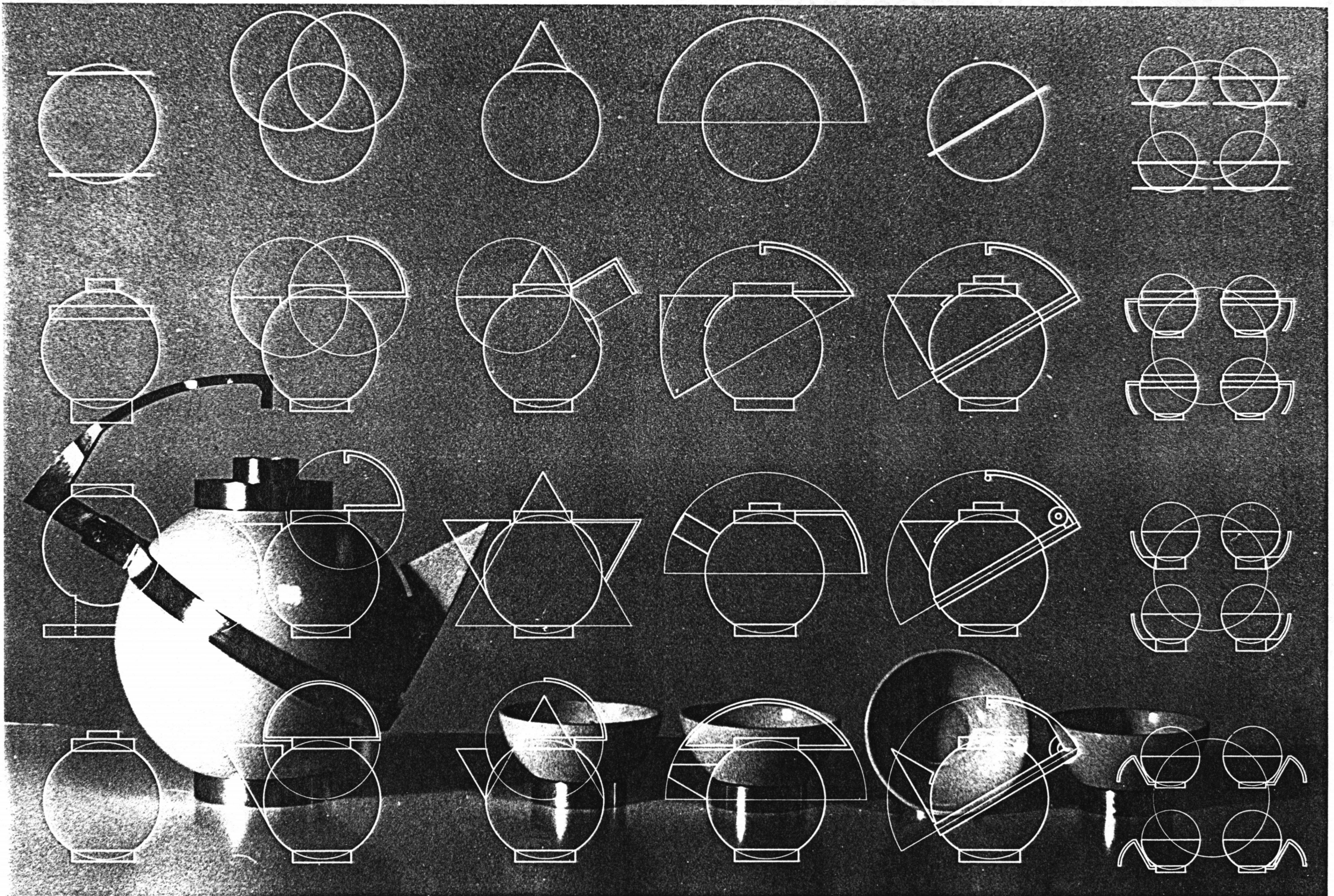

metal and clay

harmony between the rigid, the sturdy
and the fragile, the deformable

hand touches metal
metal touches clay
clay touches tea

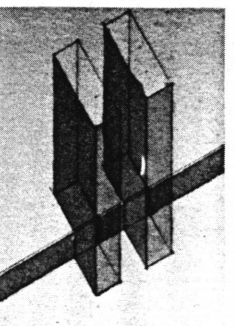



tension and compression

the hard embraces the soft
a joint serves as mediator

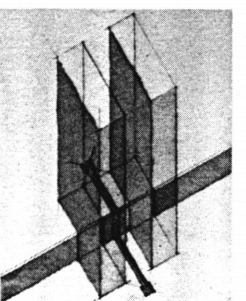
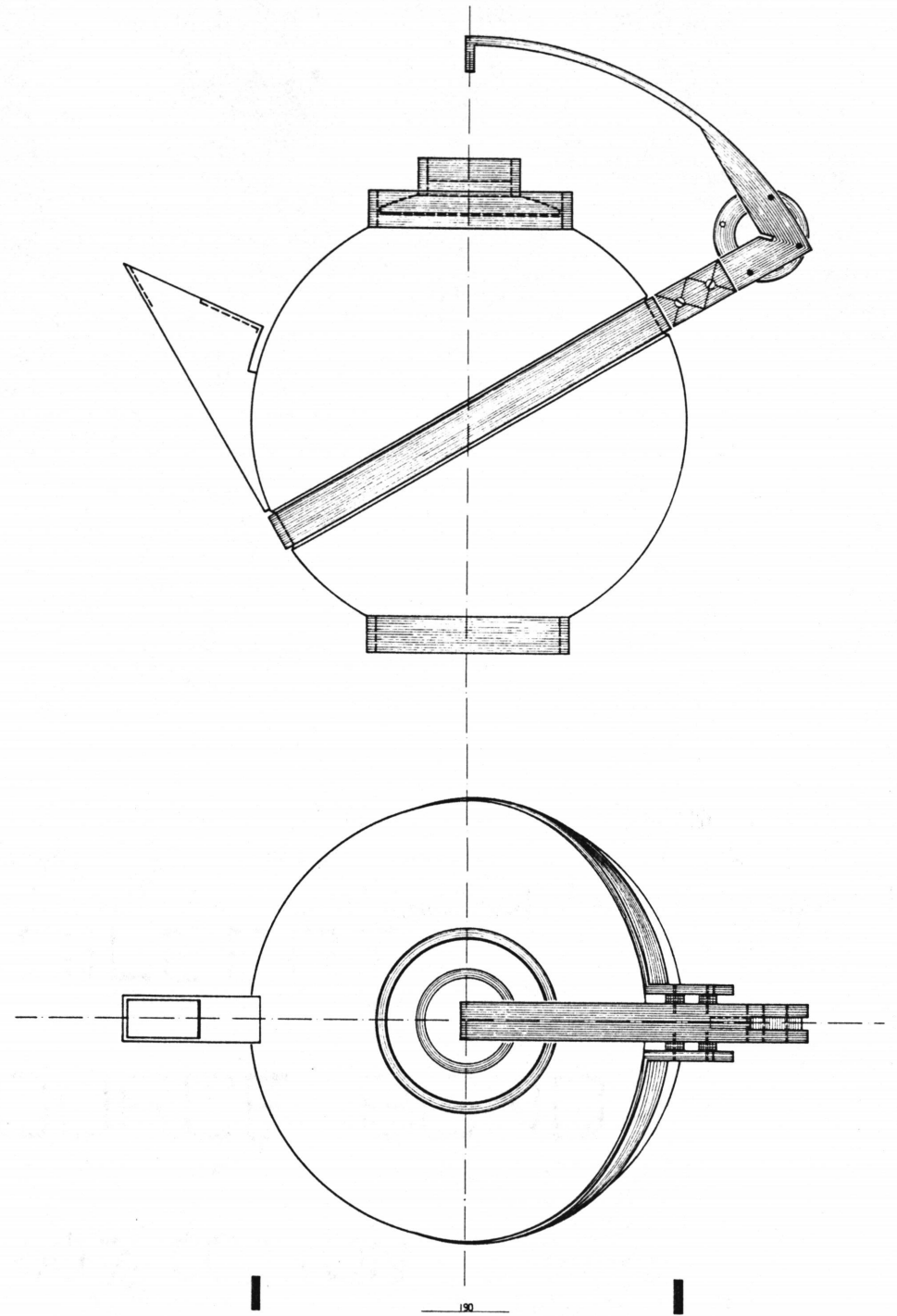

public meets private

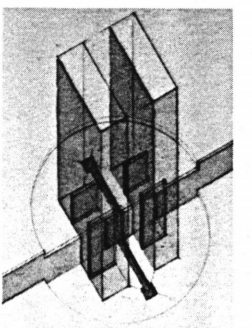
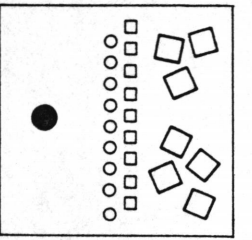

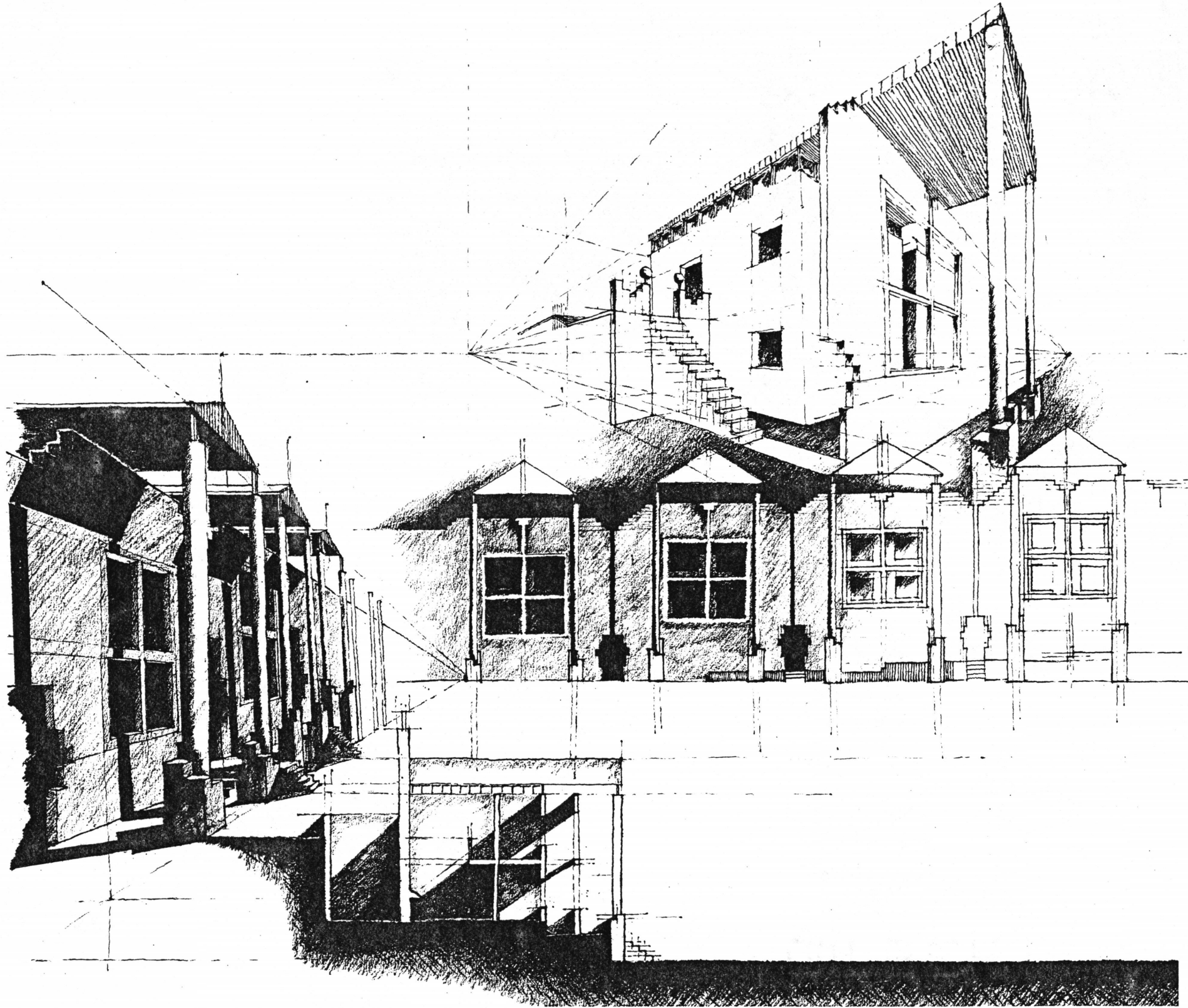

house - the most private condition

city - the most public condition

the 'in-between' - a transition between two worlds

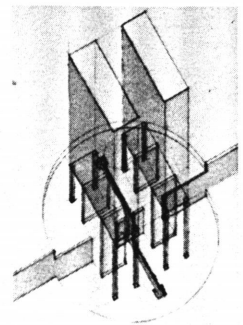

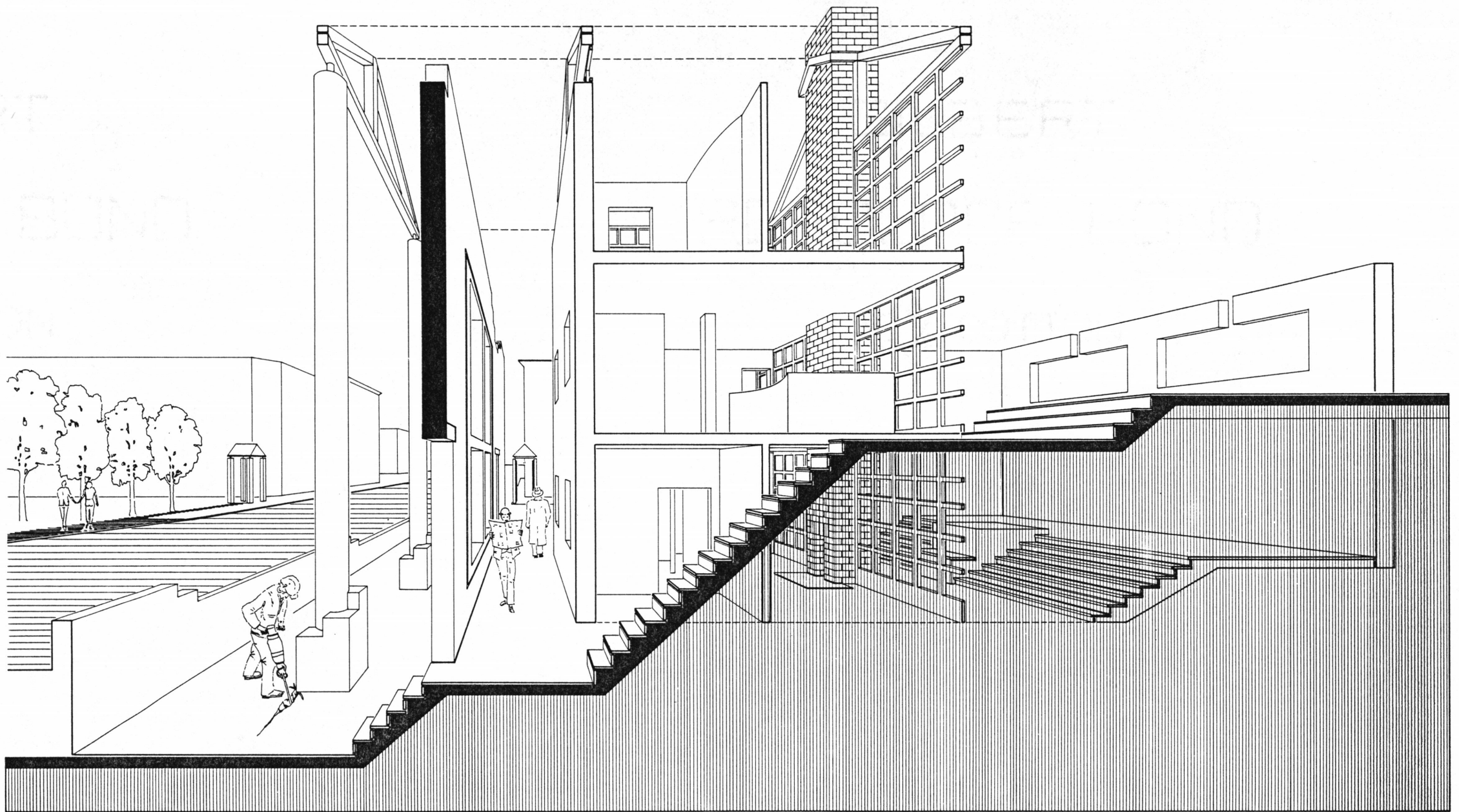

layers of the 'in-between'

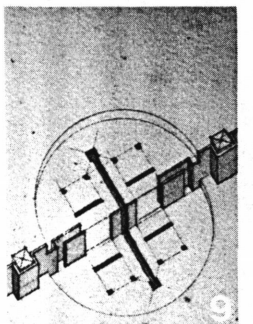
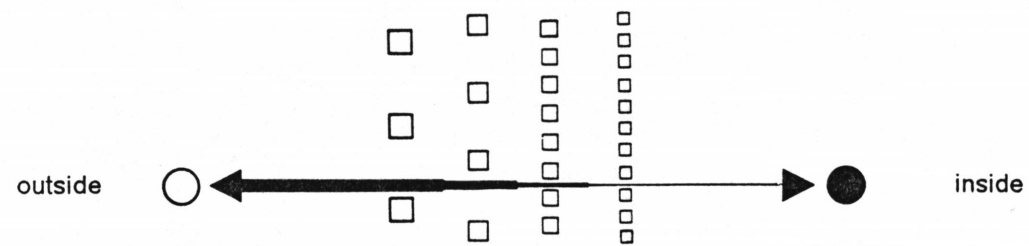

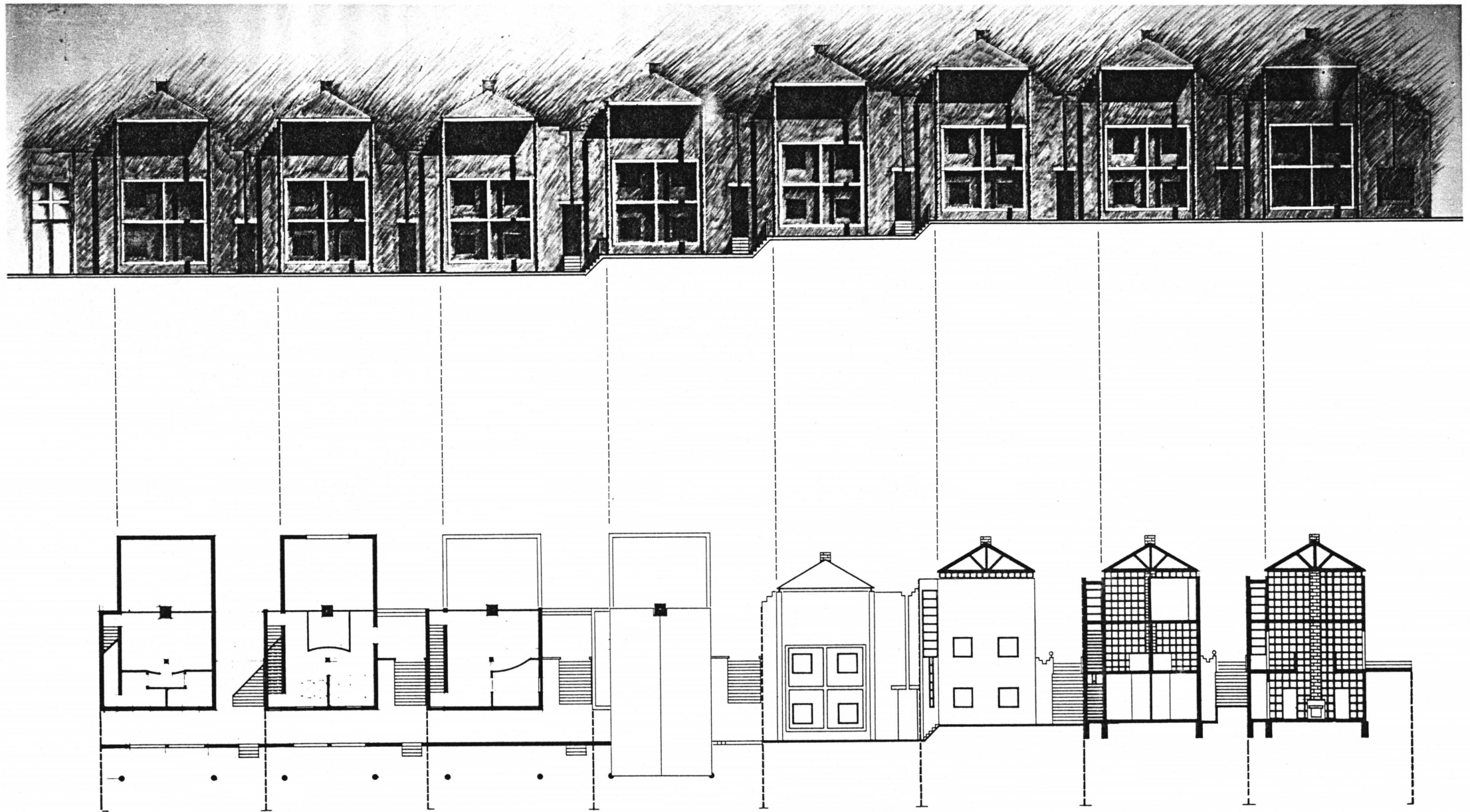

the public condition

each of the elements that signify 'house', wall, column, roof, window, and door are stripped to their bare minimum in search for 'type'.

the word 'type' represents not so much the image of a thing to be copied or perfectly imitated as the idea of an element that must itself serve as a rule for the model. 7

quatremerre de quincy

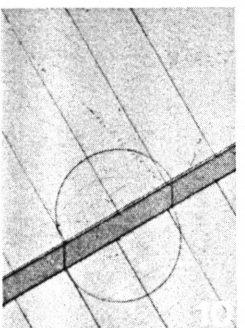

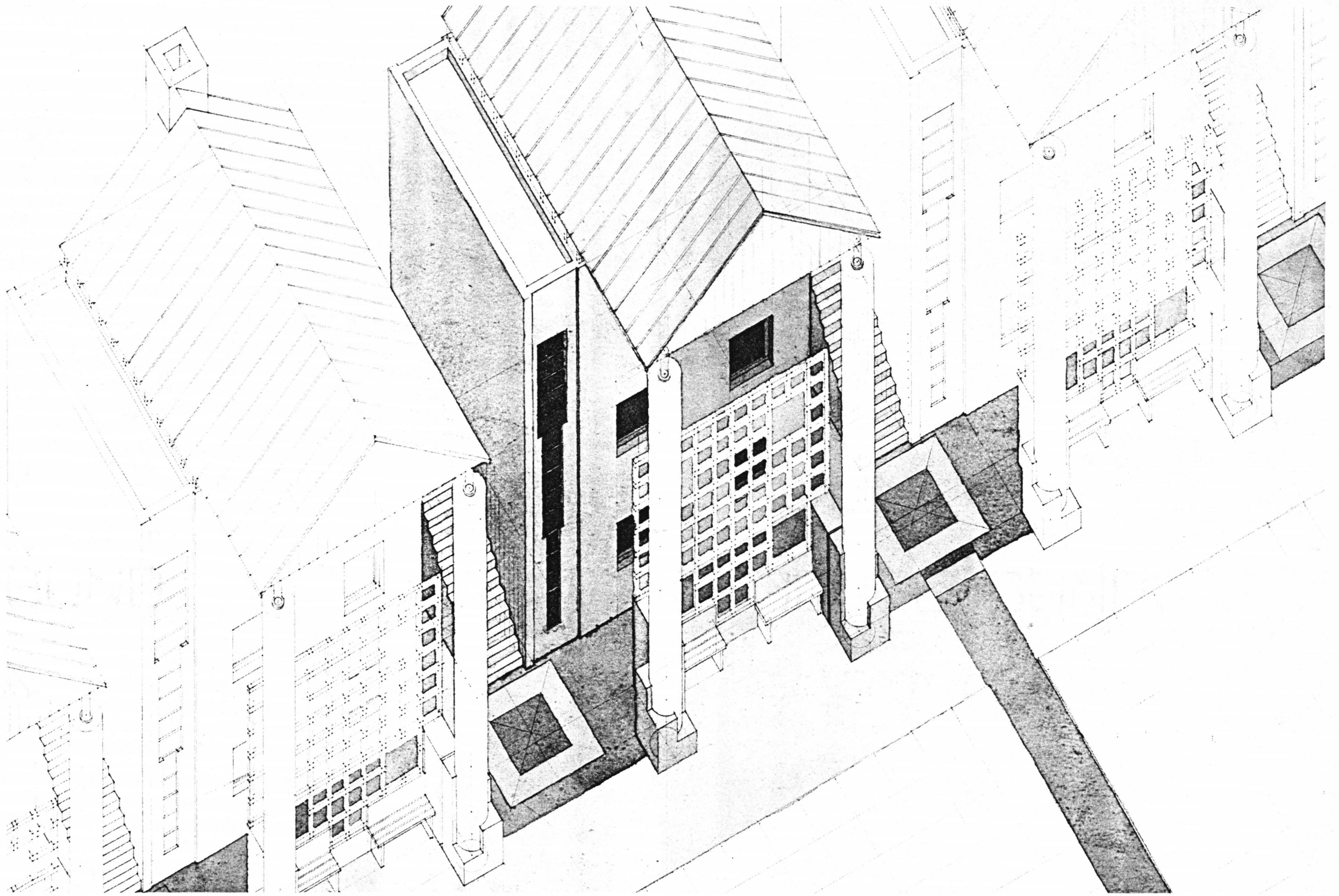

evolution of the search

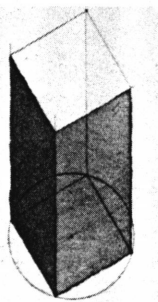

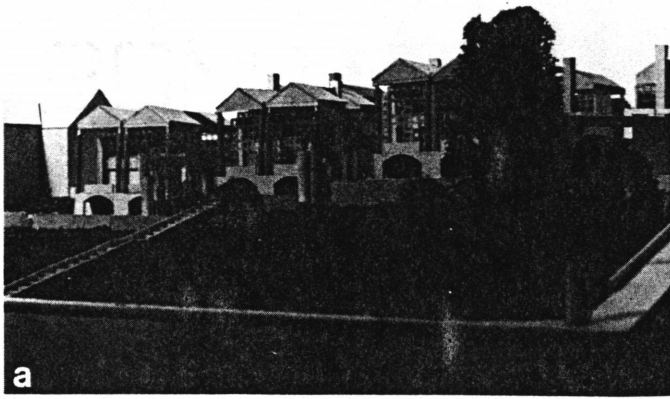

a

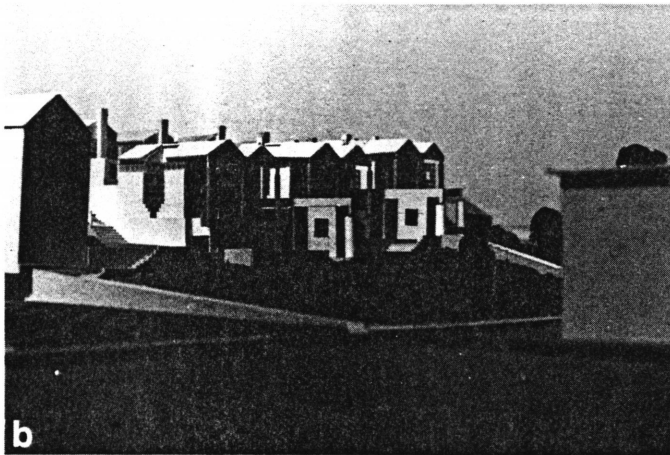

b

an offering to the town

a - view from mainstreet / college avenue

b - view from draper road / college avenue

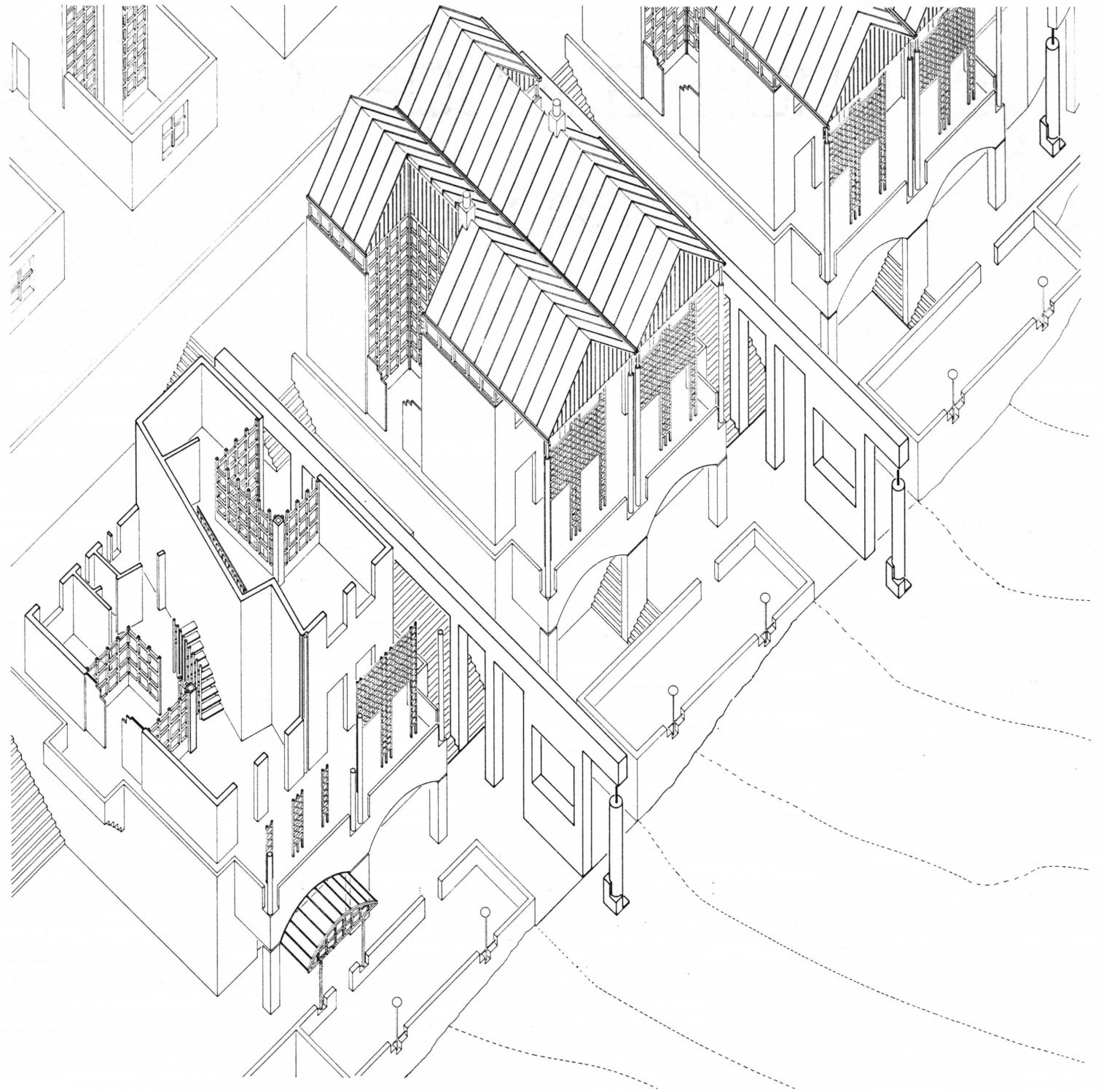

a variation of the previous housing-scheme, incorporating retail and restaurant businesses on the ground level. the scheme opposes the buildings on college avenue and establishes a backdrop for the park that concludes downtown towards the mall area.

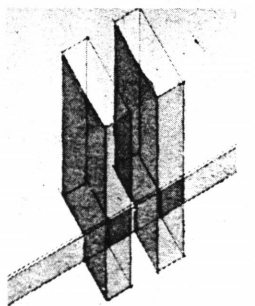

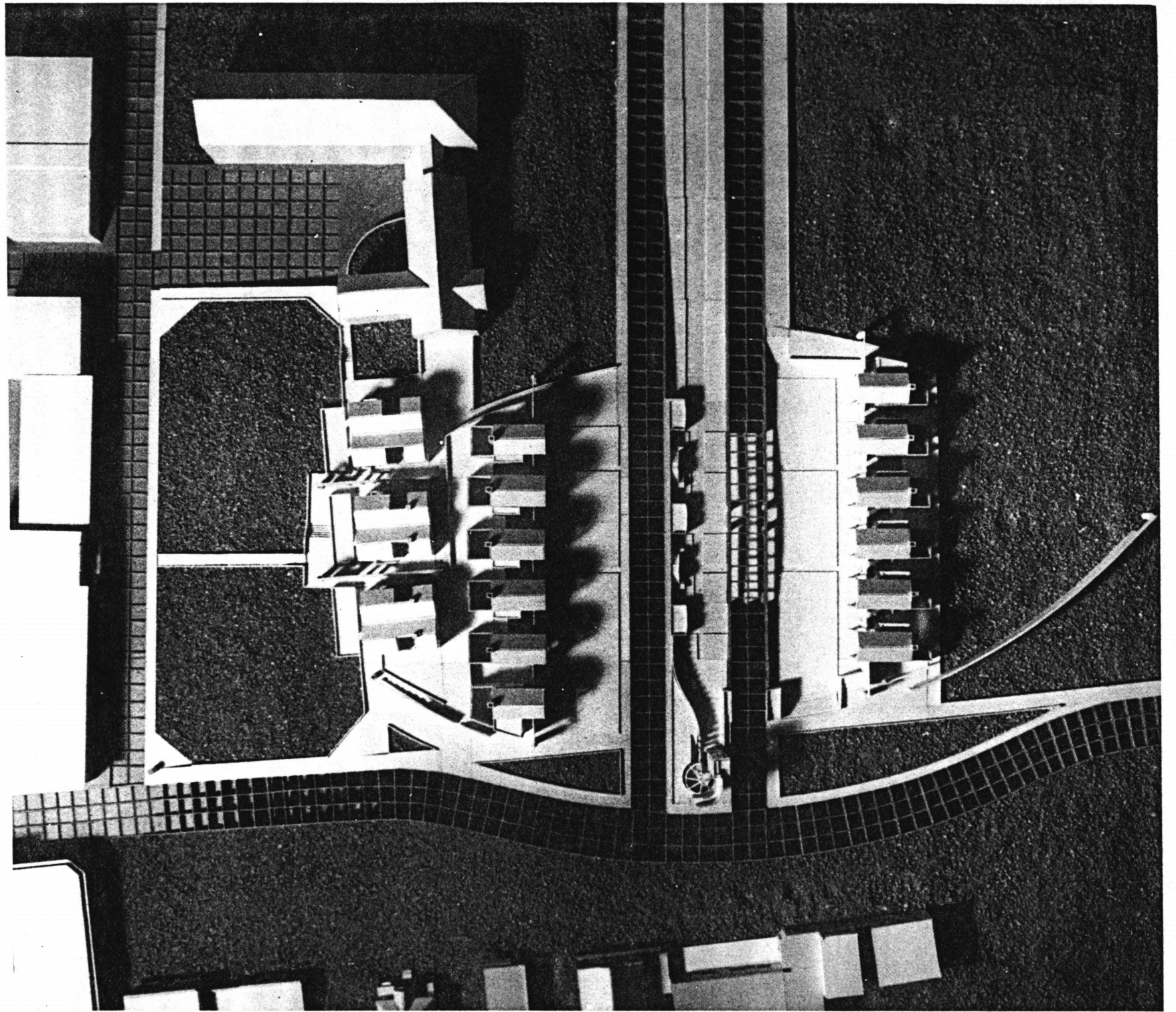

the parts in context

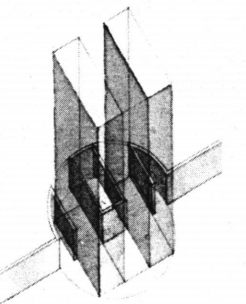

town meets university

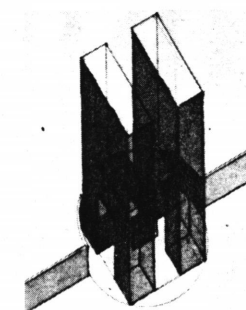
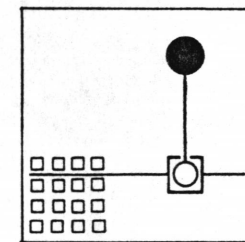

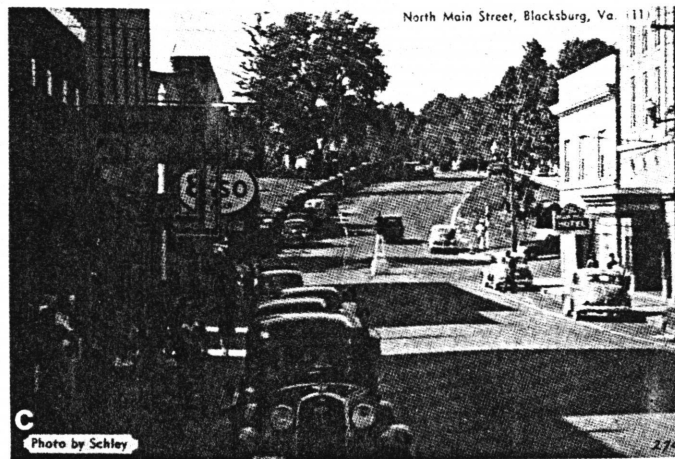
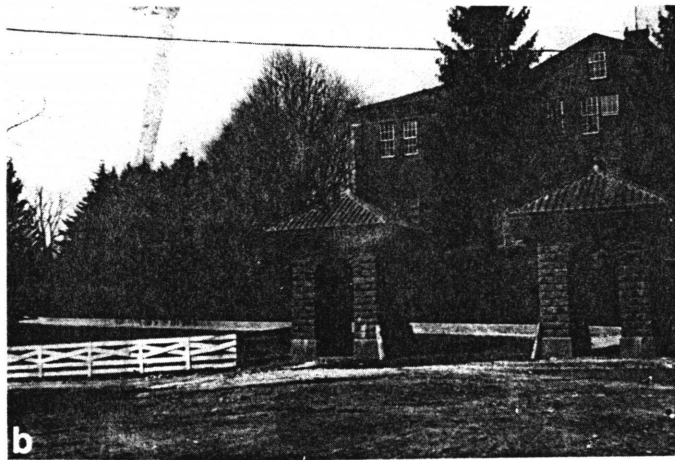

views from mainstreet, looking towards the mall area

- a - old shops building (photo 1904)
- b - alumni gateway (photo 1921)
- c - rerouting of mainstreet (photo 1949)
- d - introduction of the mall (aerial photo 1969)

history of the site

looking at the development of the site over time, the deterioration of the qualities of the site becomes obvious. the threshold between the town and the university, once clearly defined by the 'shop building' and the 'gateway' is nowadays undefined. the mall, lacking roots both in the university and in the town fabric, remains an empty gesture.

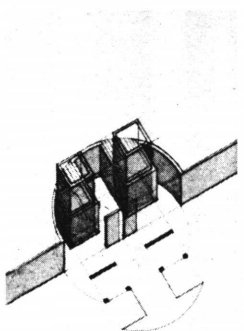

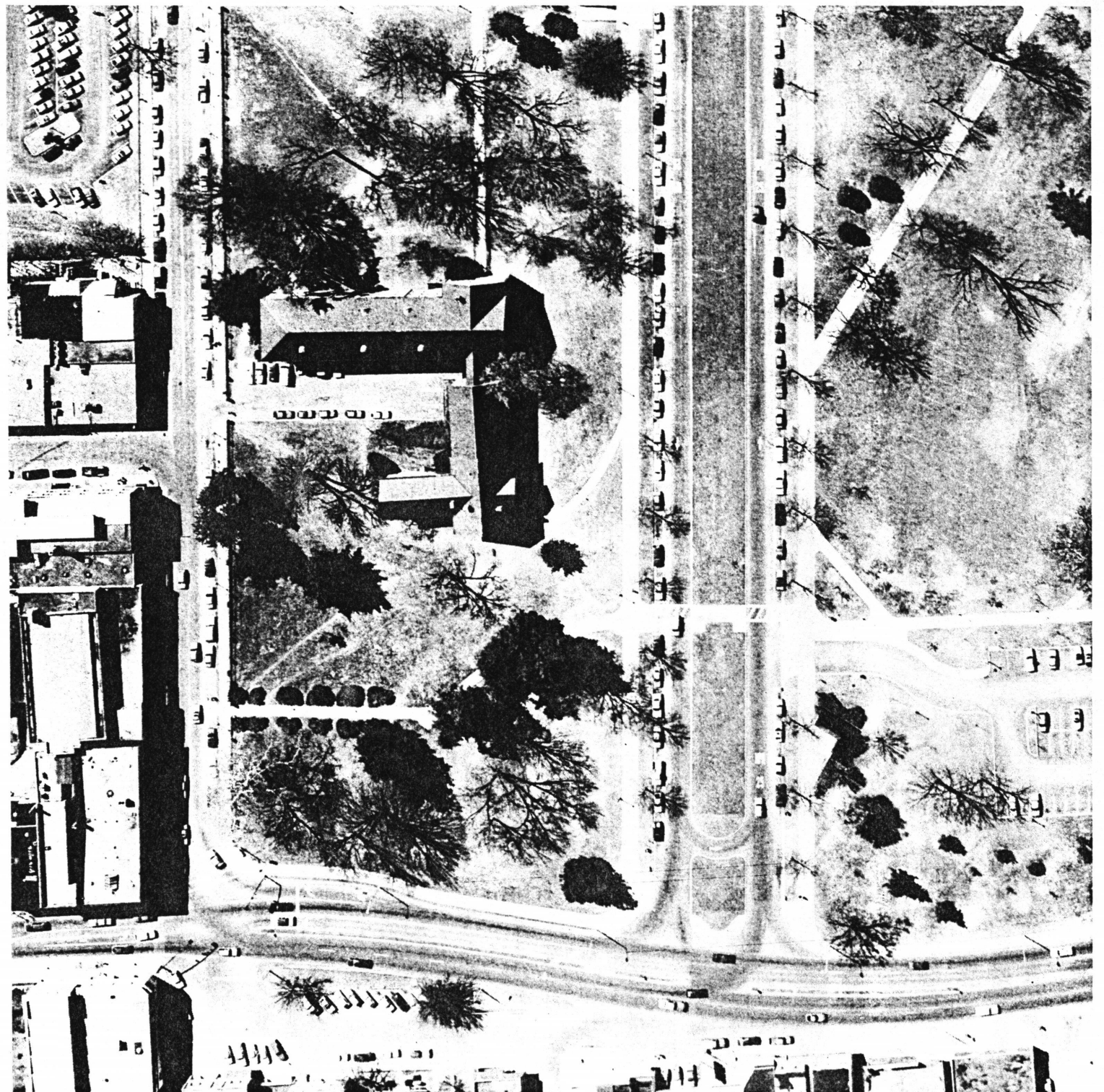
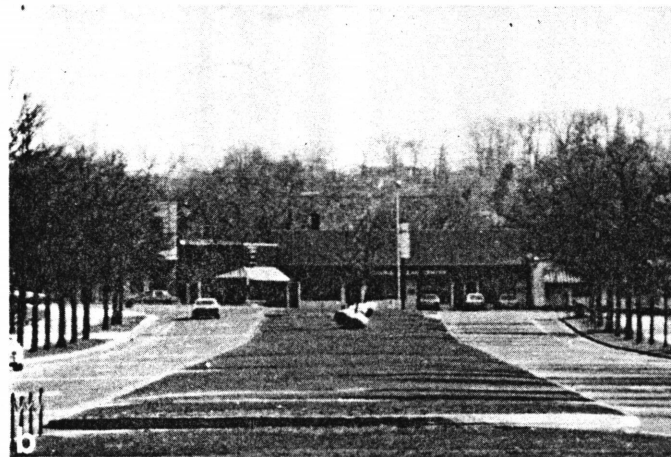
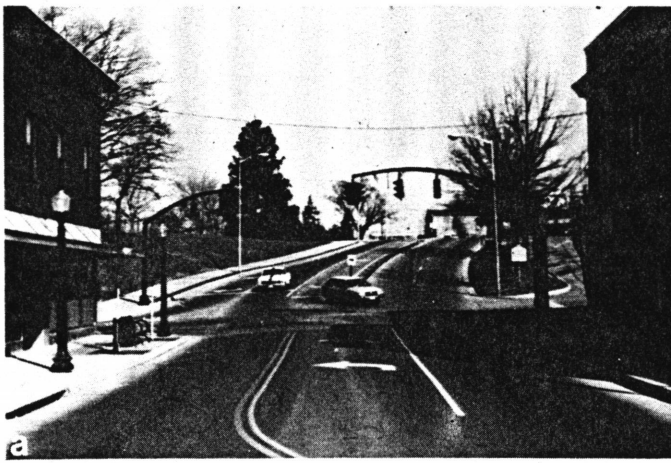

1987

there is no apparent structure on the site.
 the site is bordered (not defined) by the downtown
 fabric to the south and the east, vpi's henderson hall to
 the west and an unfortunate parking-lot to the north.
 neither the mall nor the downtown stretch of mainstreet
 find a successful termination. cook's clean center be-
 comes the focal point for the outbound university traffic.

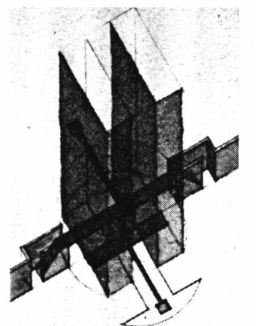

a - axial view from mainstreet

b - axial view from vpi mall

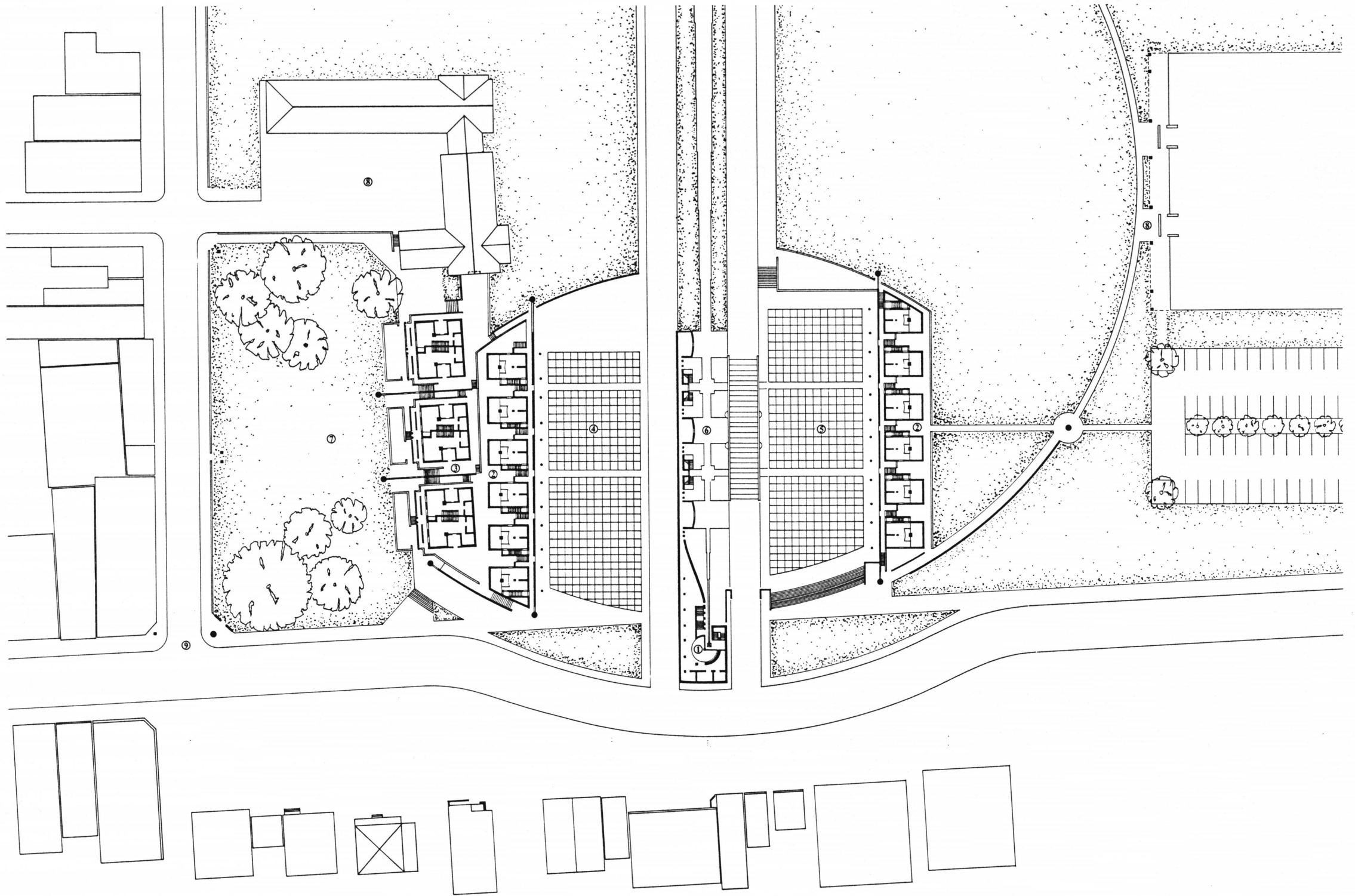

the proposal

- | | |
|---|---|
| 1 - visitor center / lookout tower (-10') | 6 - center walk / exhibition (from -10' to +0') |
| 2 - visiting faculty housing (+0' / -10') | 7 - park (from -21' to -10') |
| 3 - retail / housing (-10') | 8 - henderson hall (south), shultz hall (north) |
| 4 - upper plaza (+0') | 9 - college avenue, town level (-21') |
| 5 - lower plaza (-10') | |

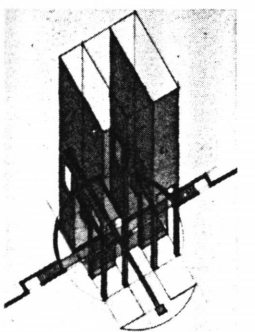

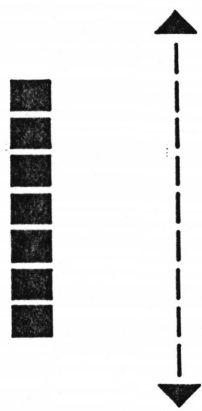
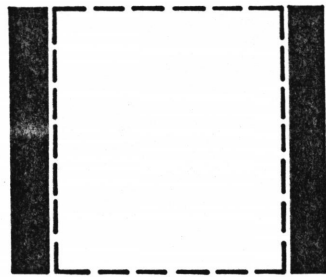
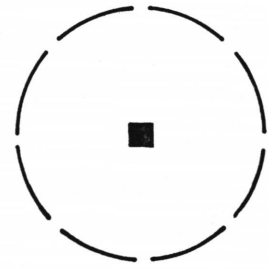
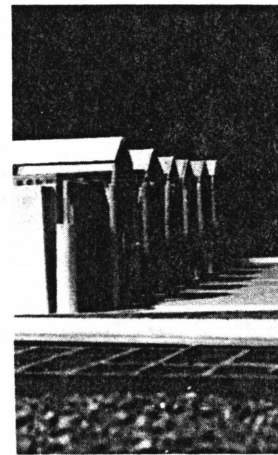
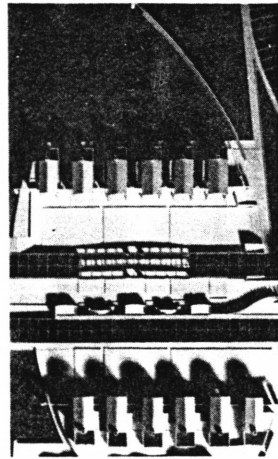
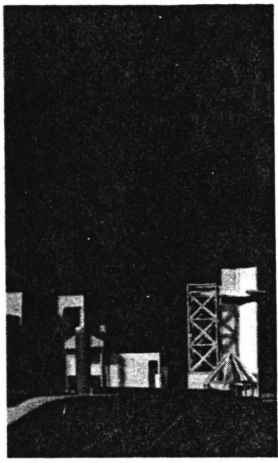

three diagrams

one - a center

two - a place

three - a direction

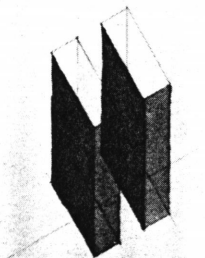
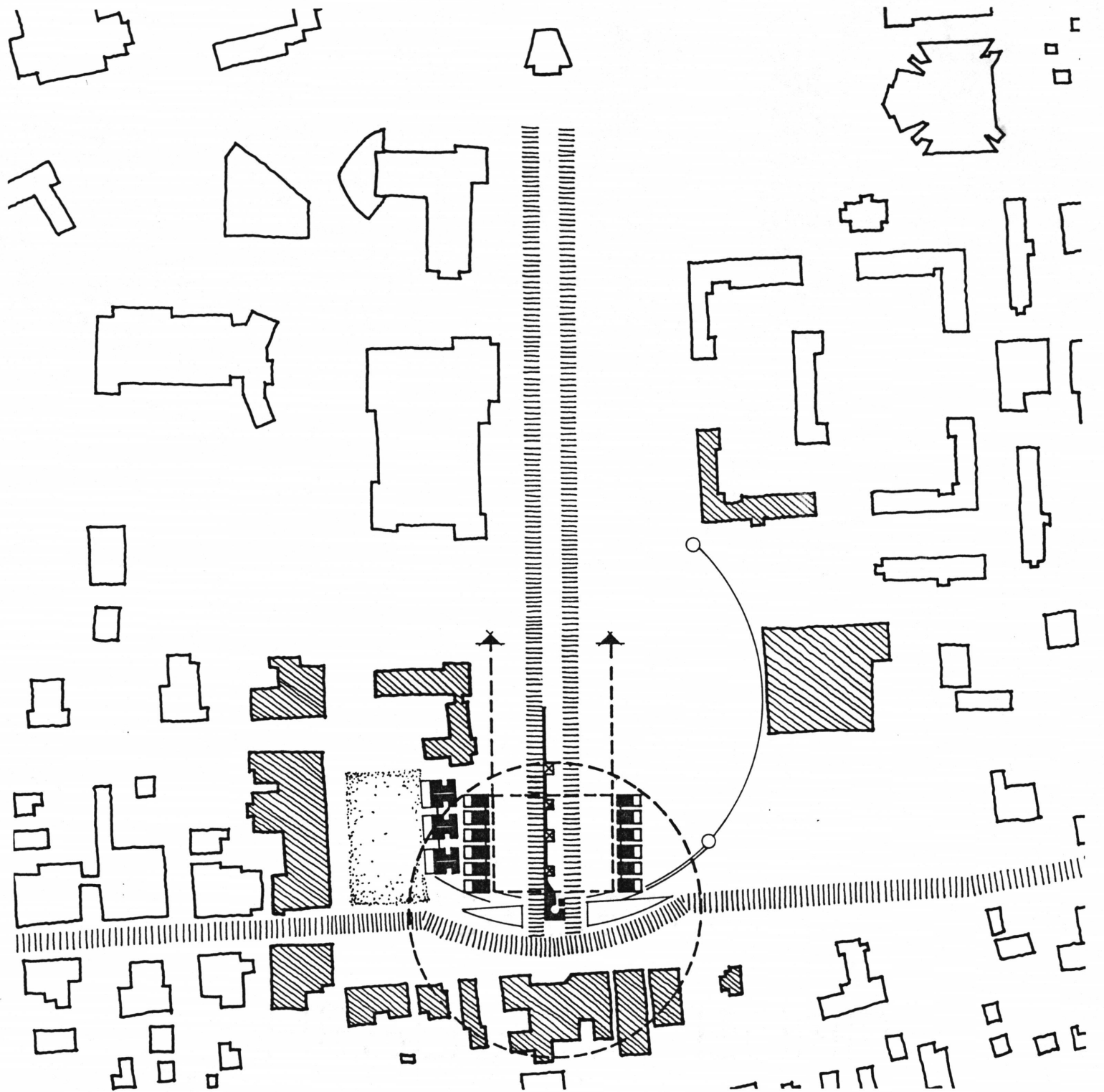

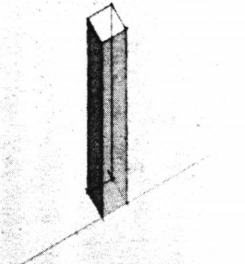
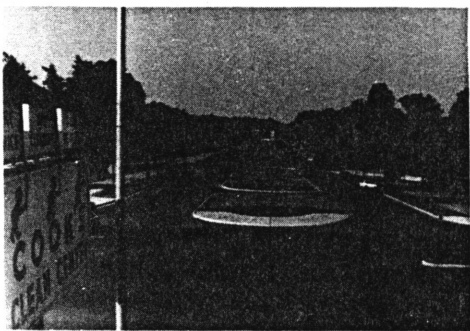
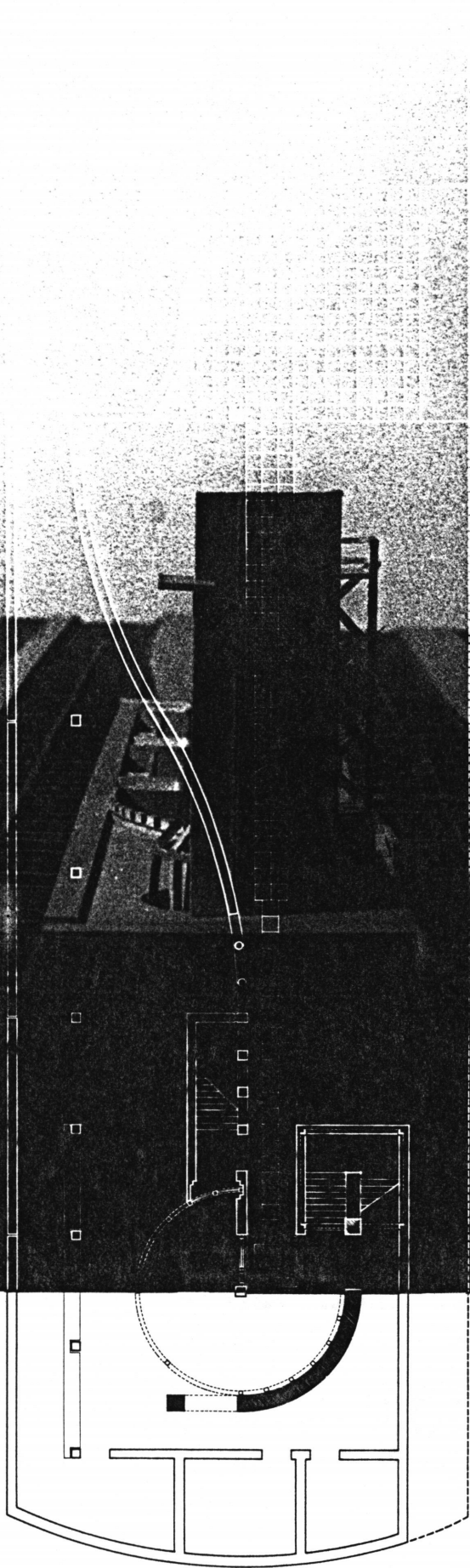
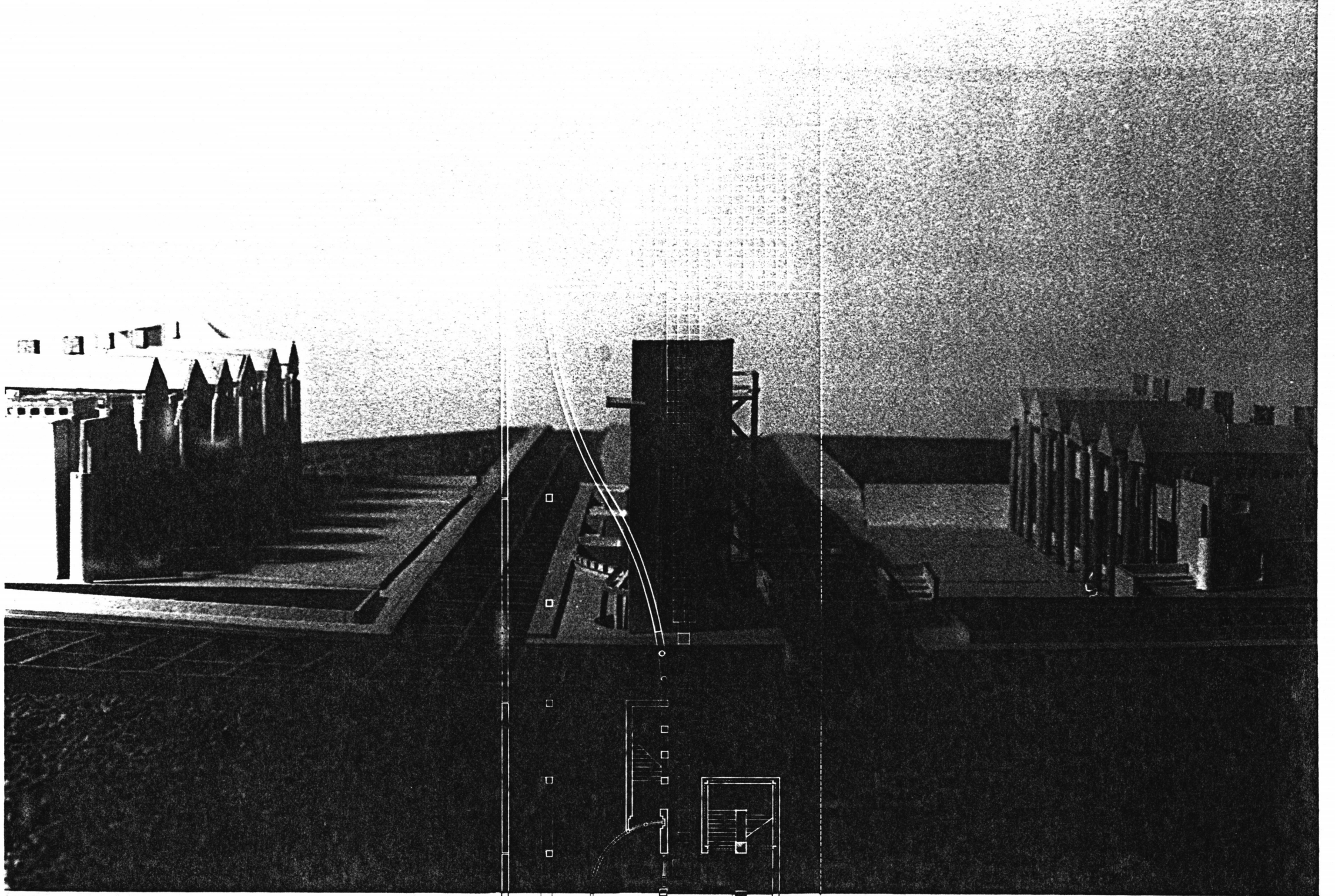

a formal plaza - an entrance to the university

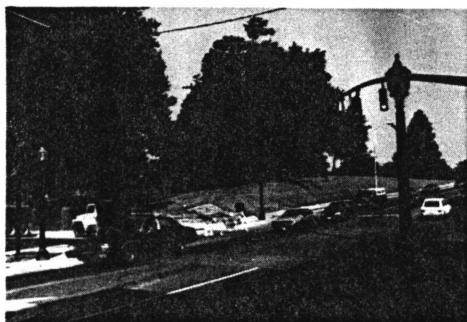
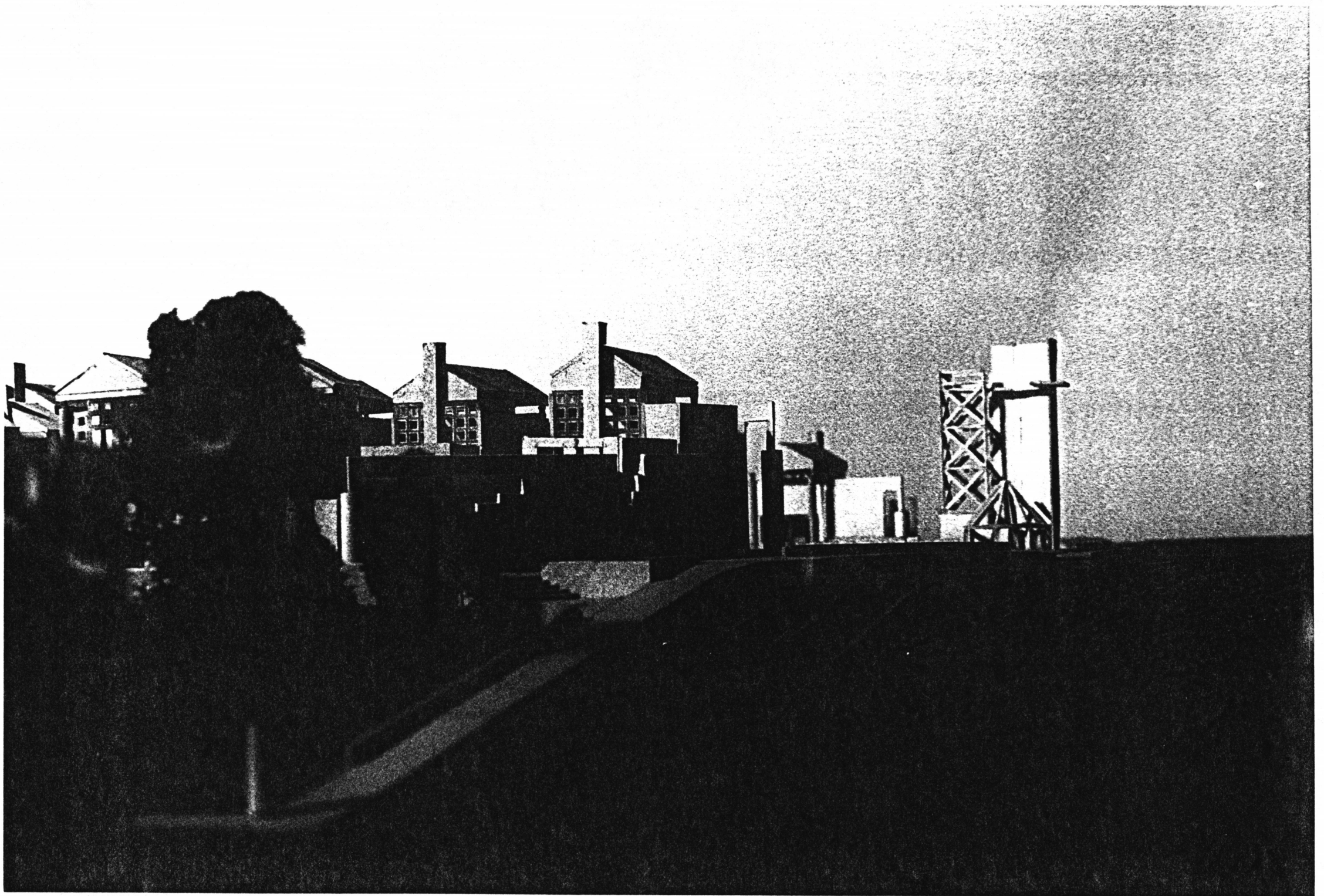

a park - an end condition for downtown



mall meets mainstreet

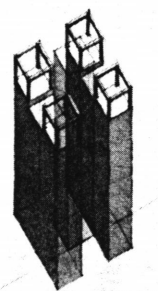
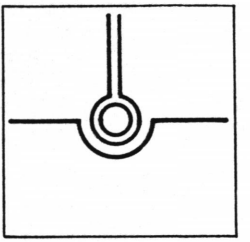

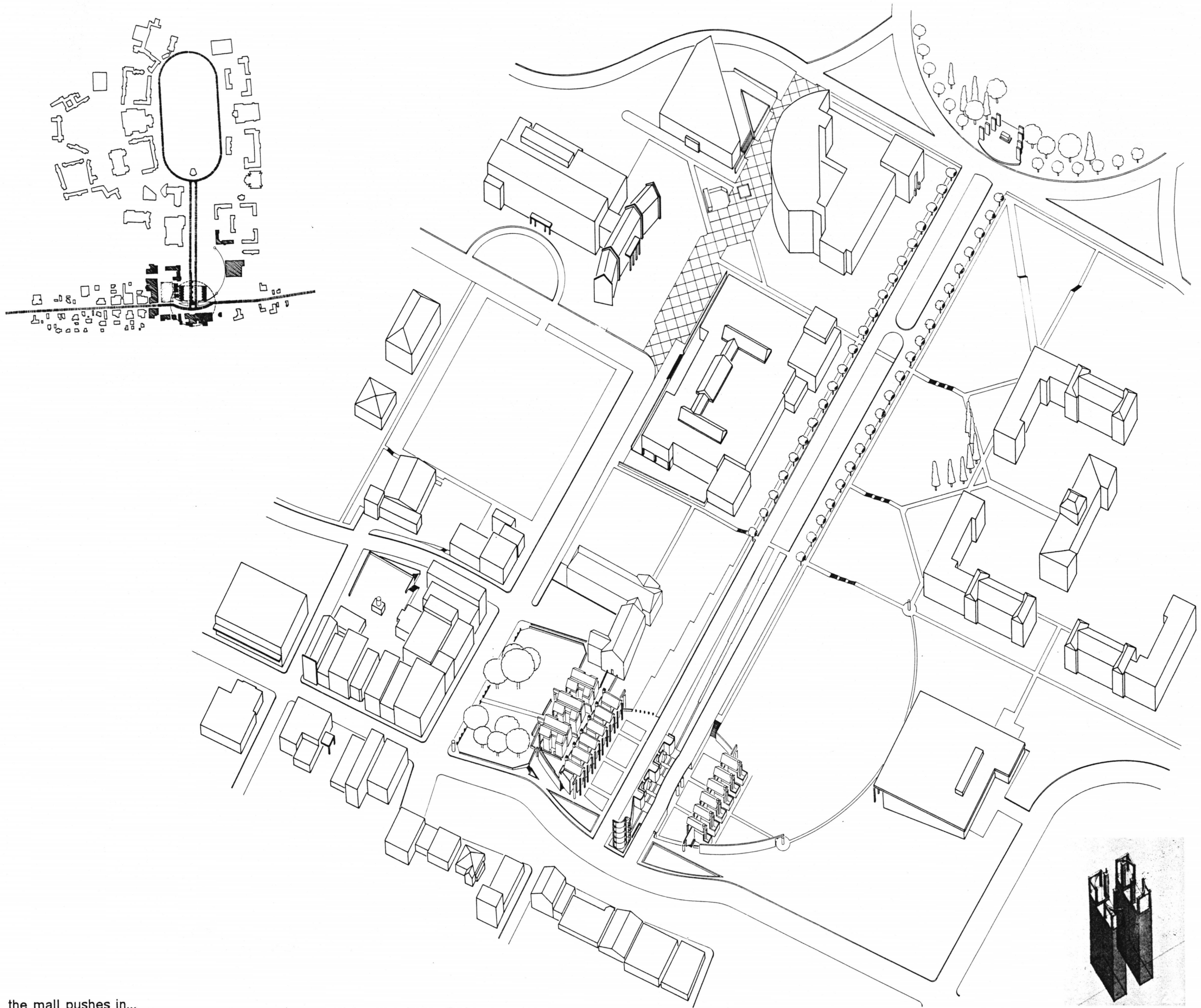

the mall pushes in...

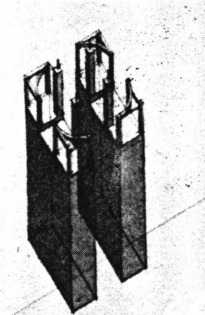

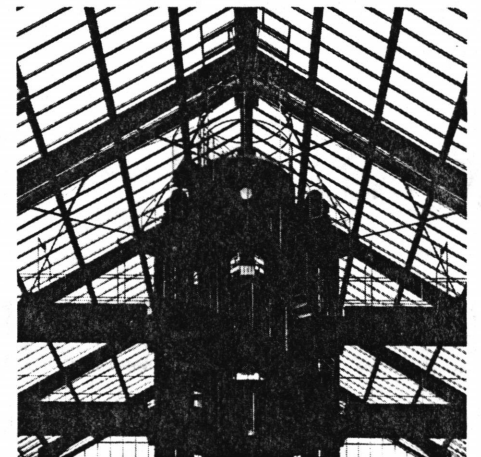
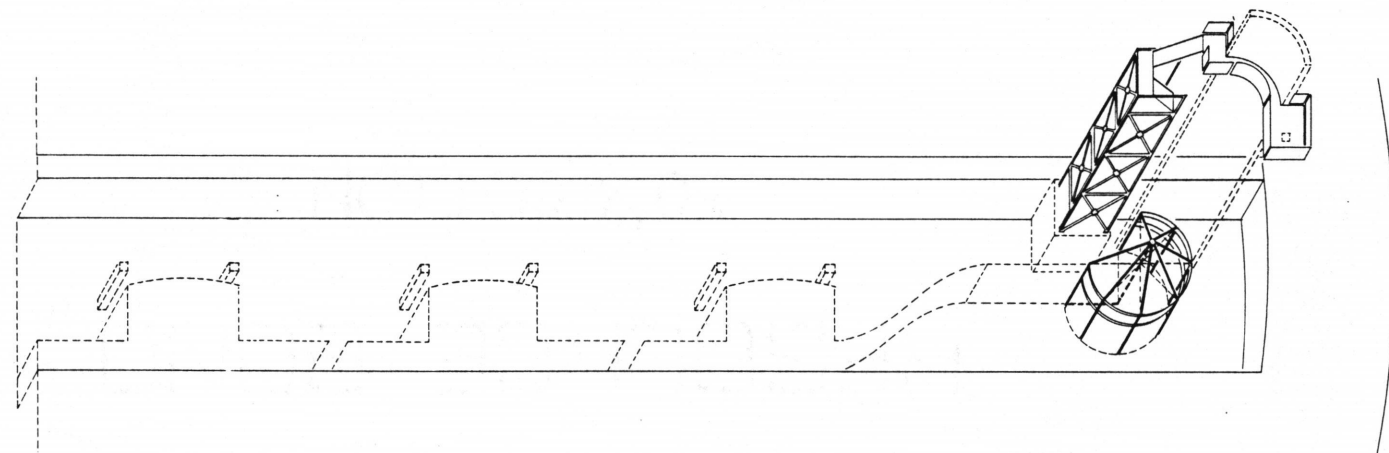
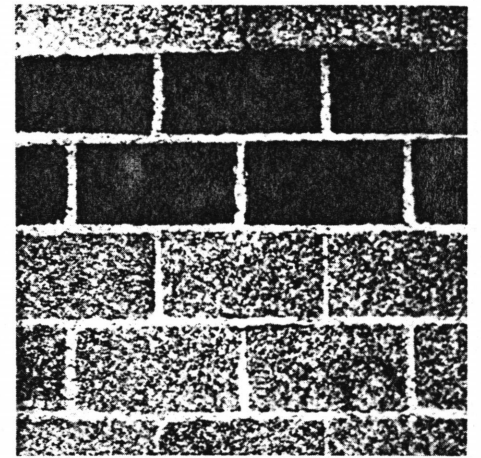
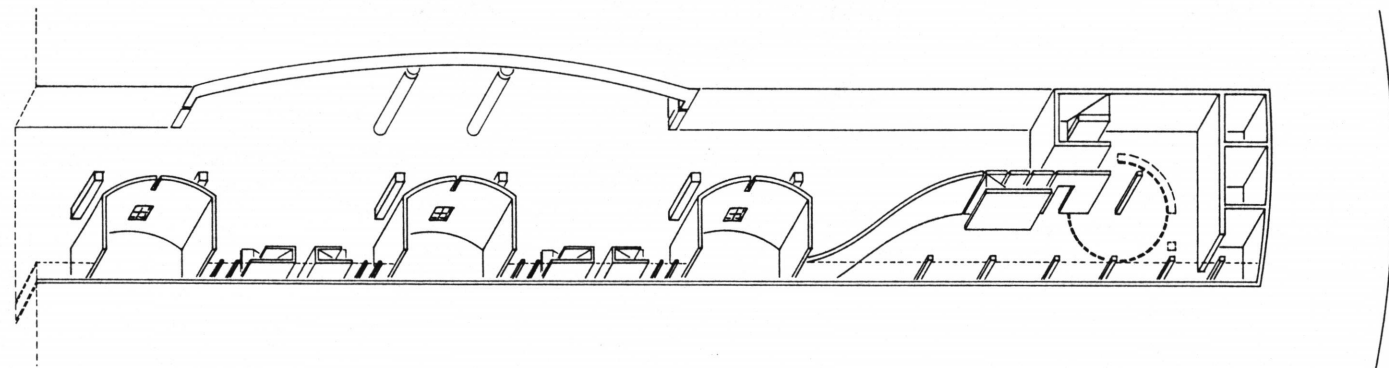
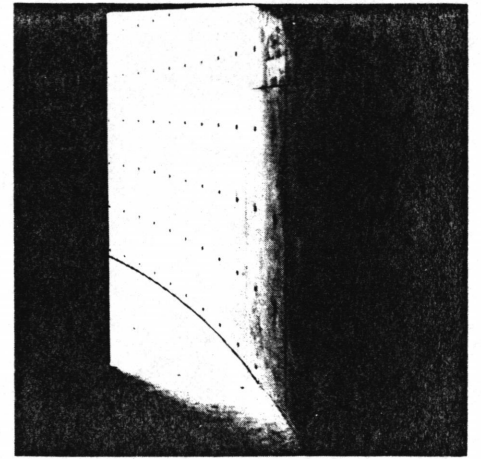
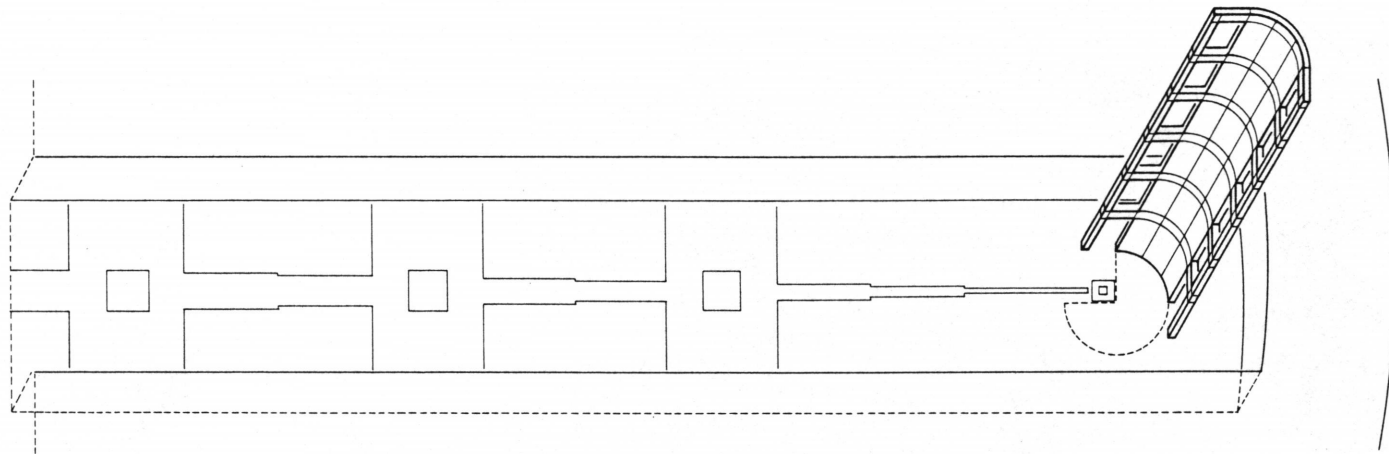

three materials

- permanent** - a quarter circle concrete slab marks the exact point where the mall and mainstreet meet
- intermediate** - a block wall with exhibition pavillions defines a walkway that physically connects mainstreet and the drillfield
- temporary** - steel and glass structures accommodate the functions of the visitor center

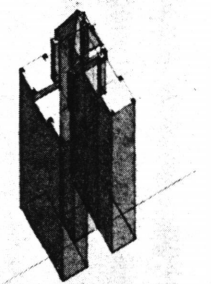

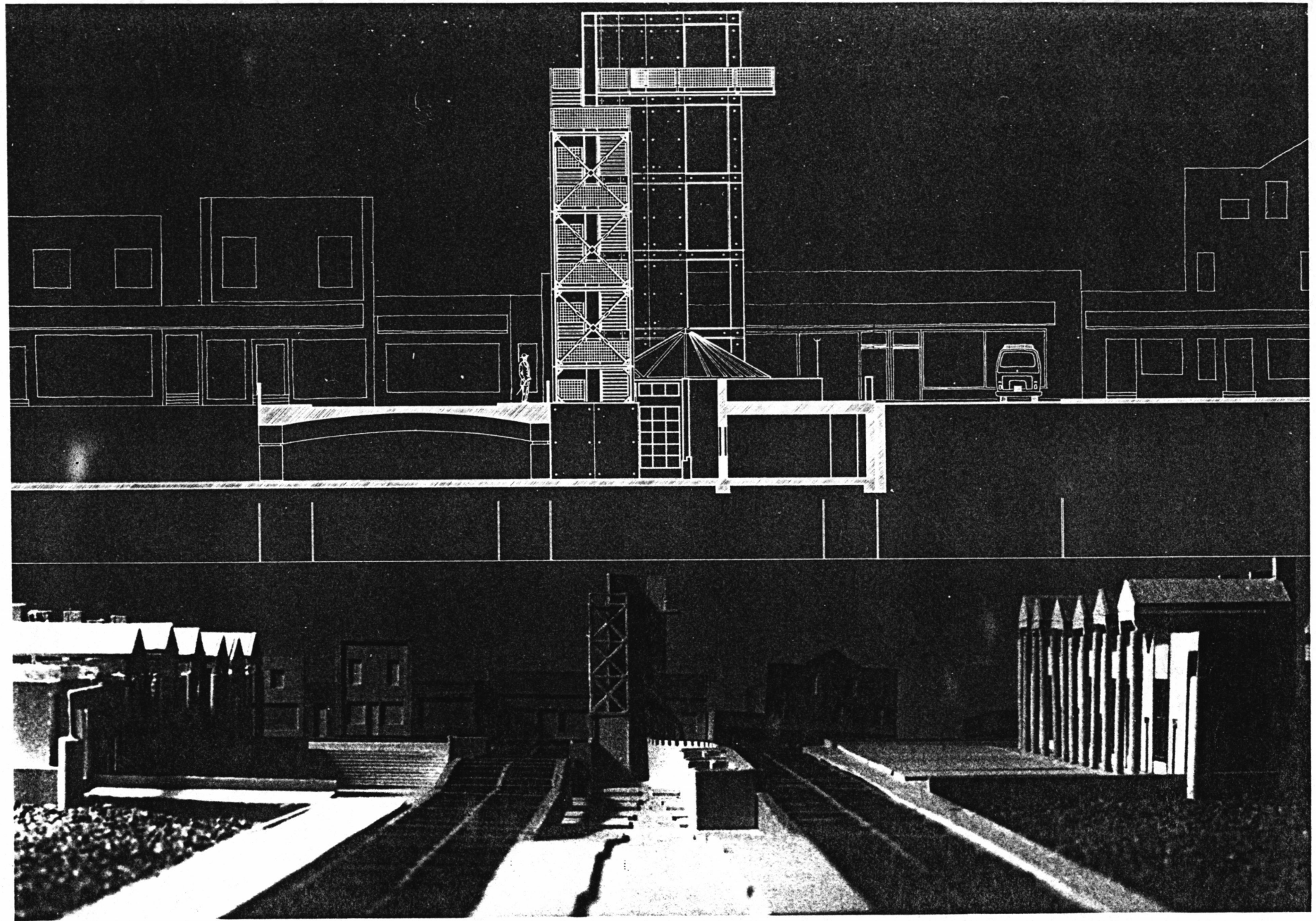

section through mainstreet

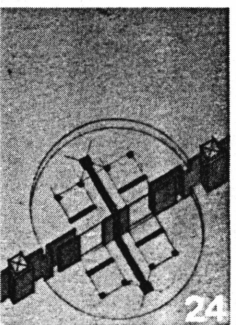
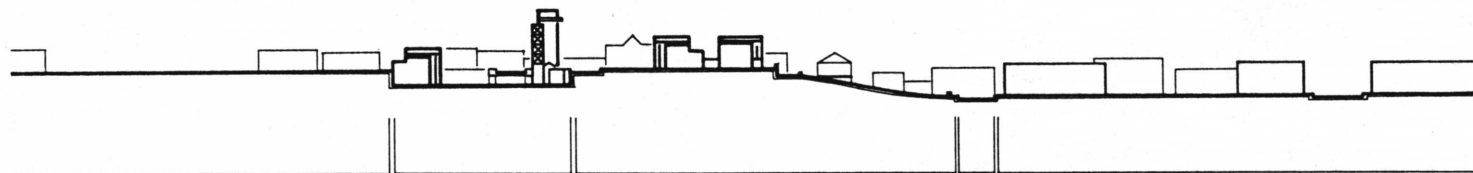

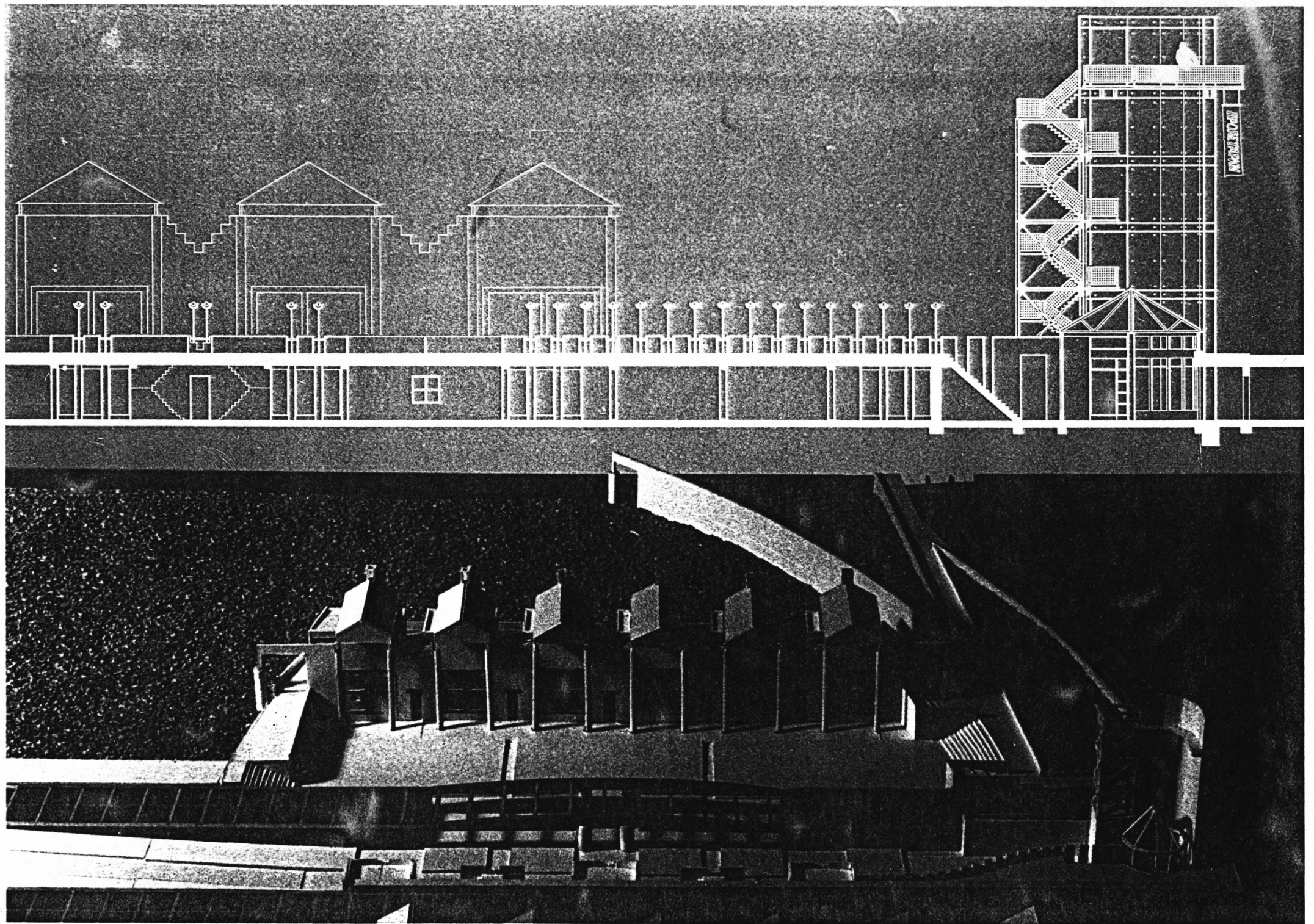

section through mall

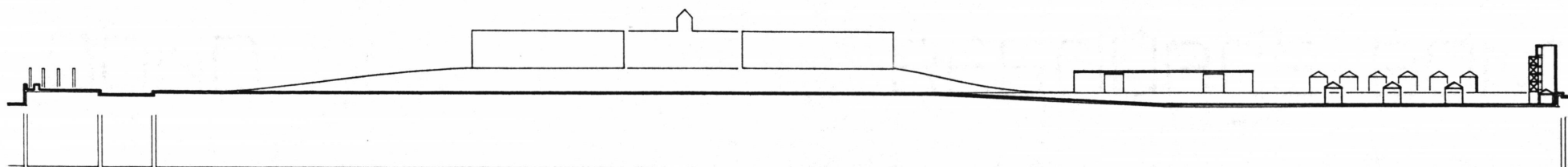

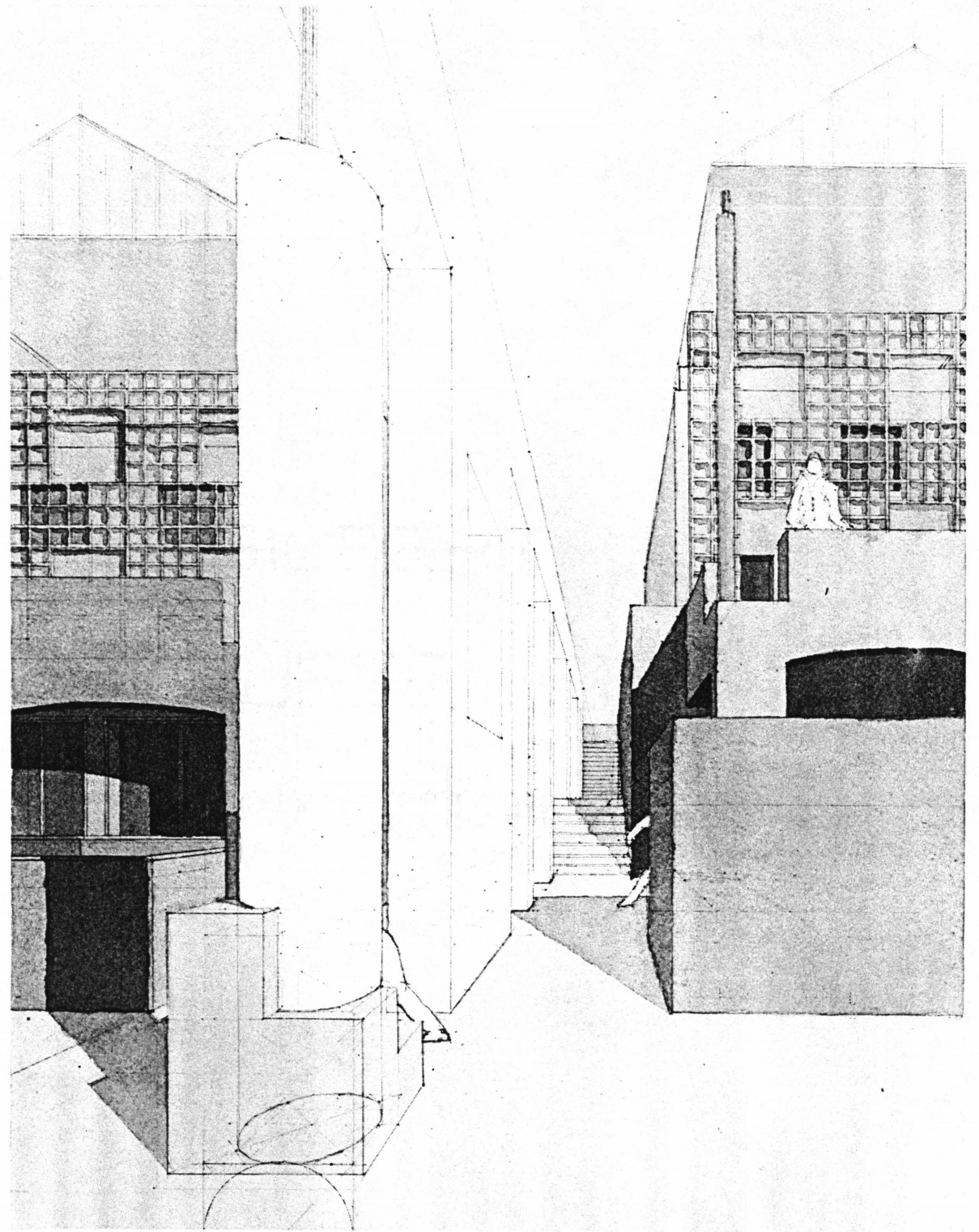
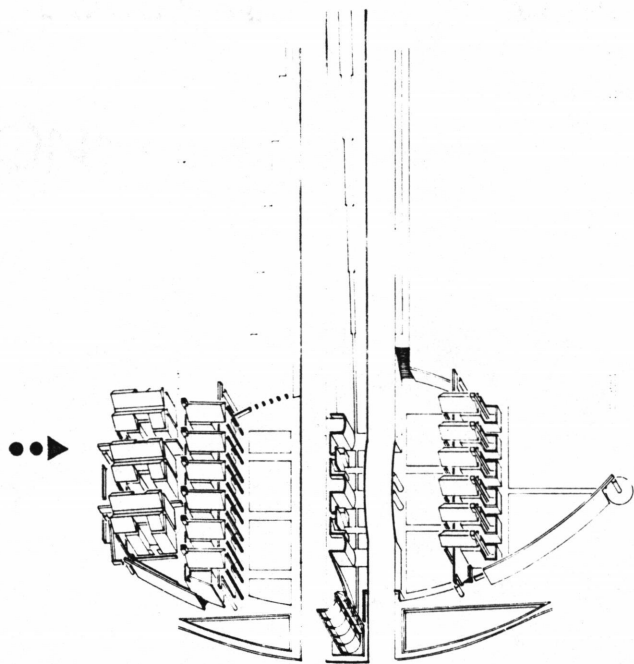

four urban conditions

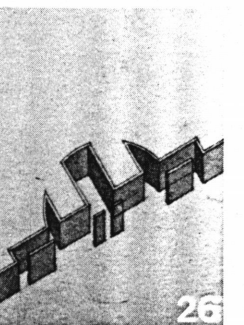

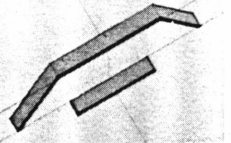
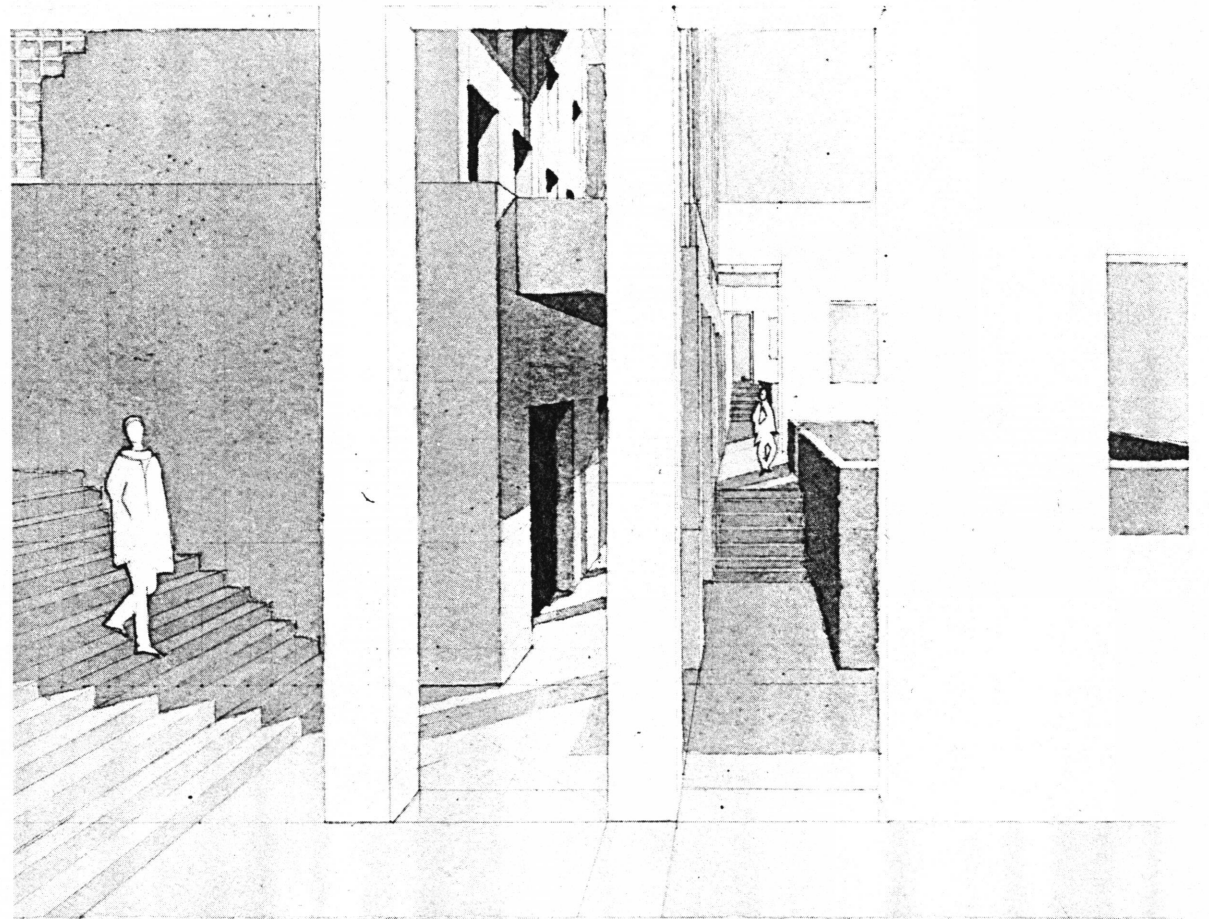
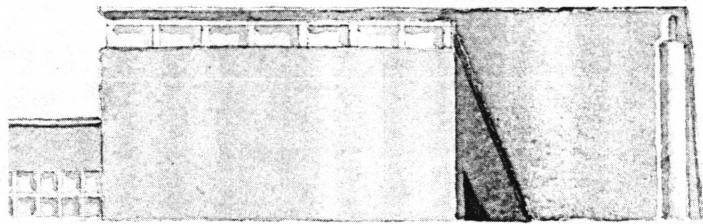
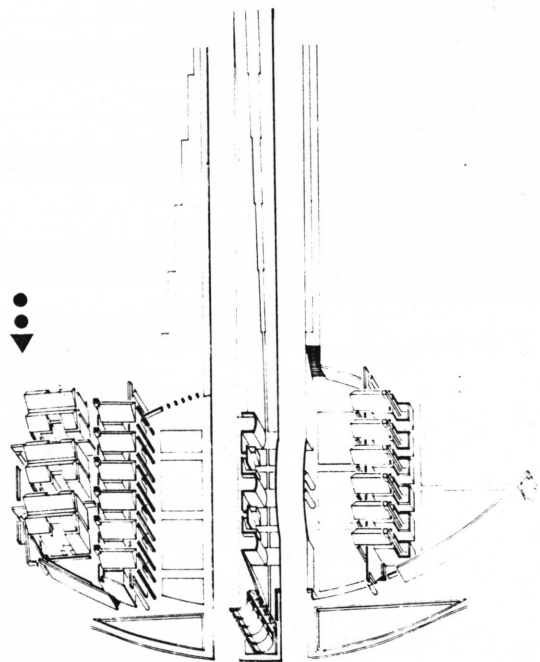

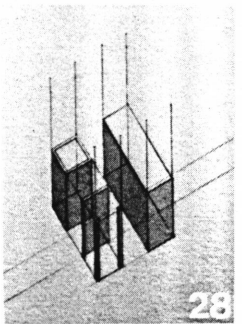
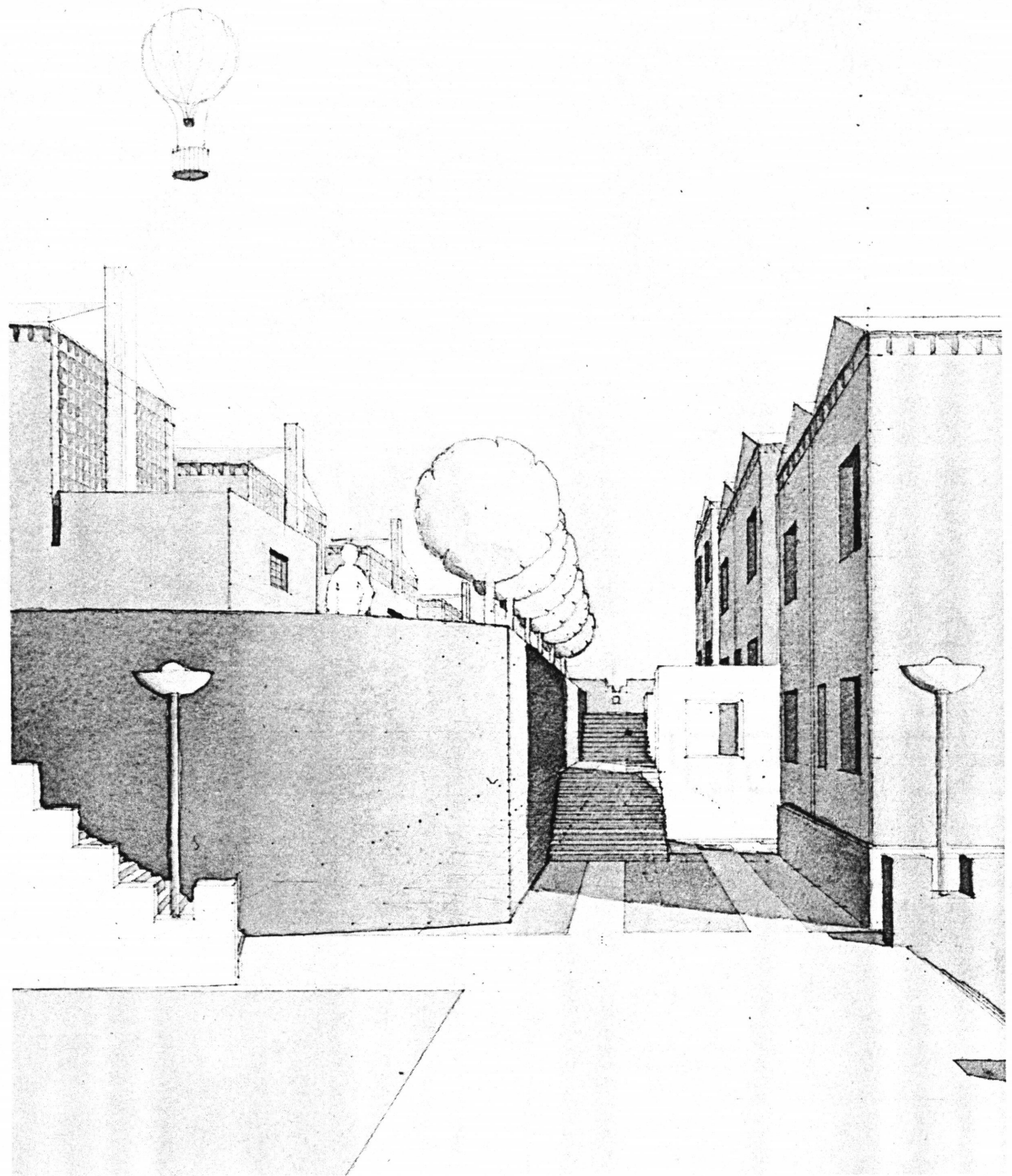
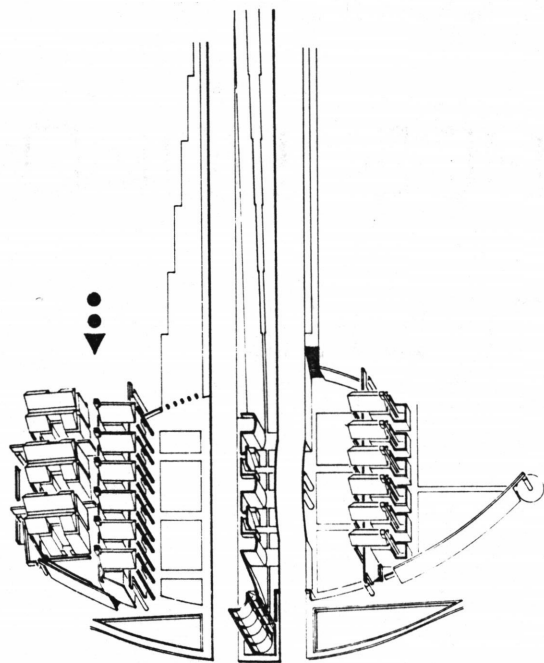

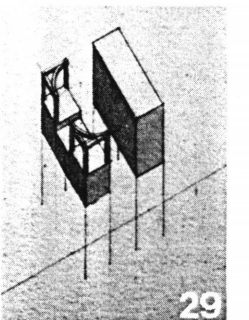
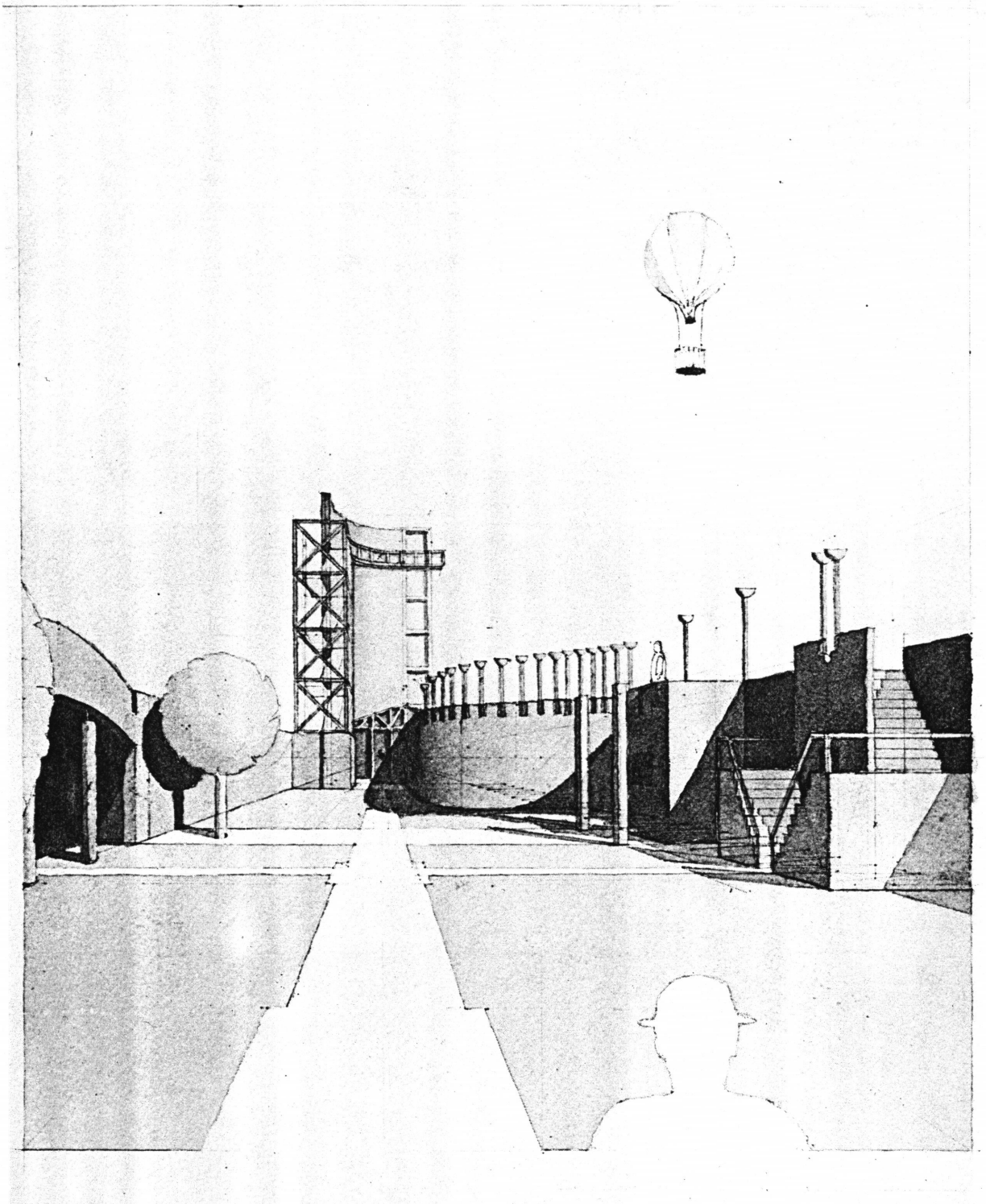
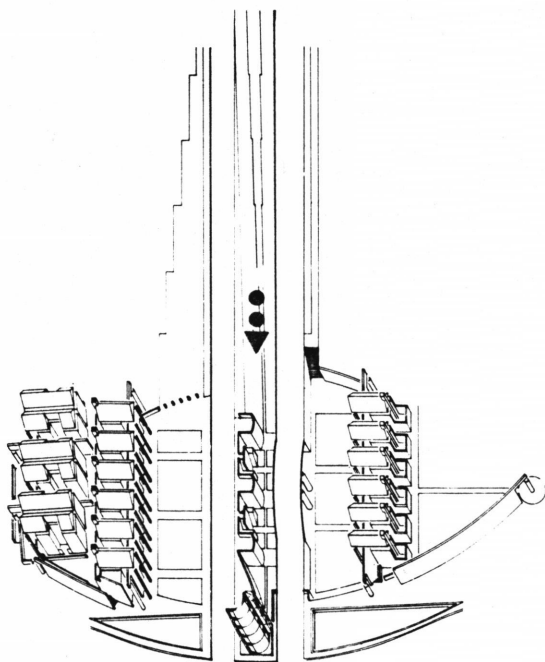

bibliography

notes

1. kahn, louis i.: *between silence and light*, shambala publications, boulder, 1979, p.56.
2. aristotle: *nicomachean ethics*, translated by w. d. ross, in *works*, vol.IX (1925), p.1094a1 ff.
3. le corbusier: *the city of tomorrow*, m.i.t. press, cambridge, 1971; p.40.
4. aristotle: *nichomachean ethics*, p.1140a1 ff.
5. kahn louis i.: *between silence and light*, p.28.
6. rossi, aldo: *three cities*, edizione pannini, modena, 1984; introduction.
7. quatremere de quincy, antoine: *dictionnaire historique d'Architecture*, librairie d'adrien le clere, 1832, vol.1, 2.

selected readings

- hofstadter/kuhns (editors): *philosophies of art and beauty*, the university of chicago press, chicago, 1964.
- colquhoun, alan: *essays in architectural criticism*, m.i.t. press, cambridge, 1981.
- rossi, aldo: *the architecture of the city*, m.i.t. press, cambridge, 1982.
- ungers, oswald m.: *die thematisierung der Architektur* d.v.a., stuttgart, 1983.
- norberg-schulz, christian: *genius loci*, rizzoli international, new york, 1980.

**The vita has been removed from
the scanned document**