

# Squires Student Center

by  
Michael Maichak

Thesis submitted to the faculty of the Virginia Polytechnic  
Institute and State University in partial fulfillment of  
the requirement for the degree of .

MASTER OF ARCHITECTURE

Approved;

Denis Kilper

Len D. Singer

Donna Dunay

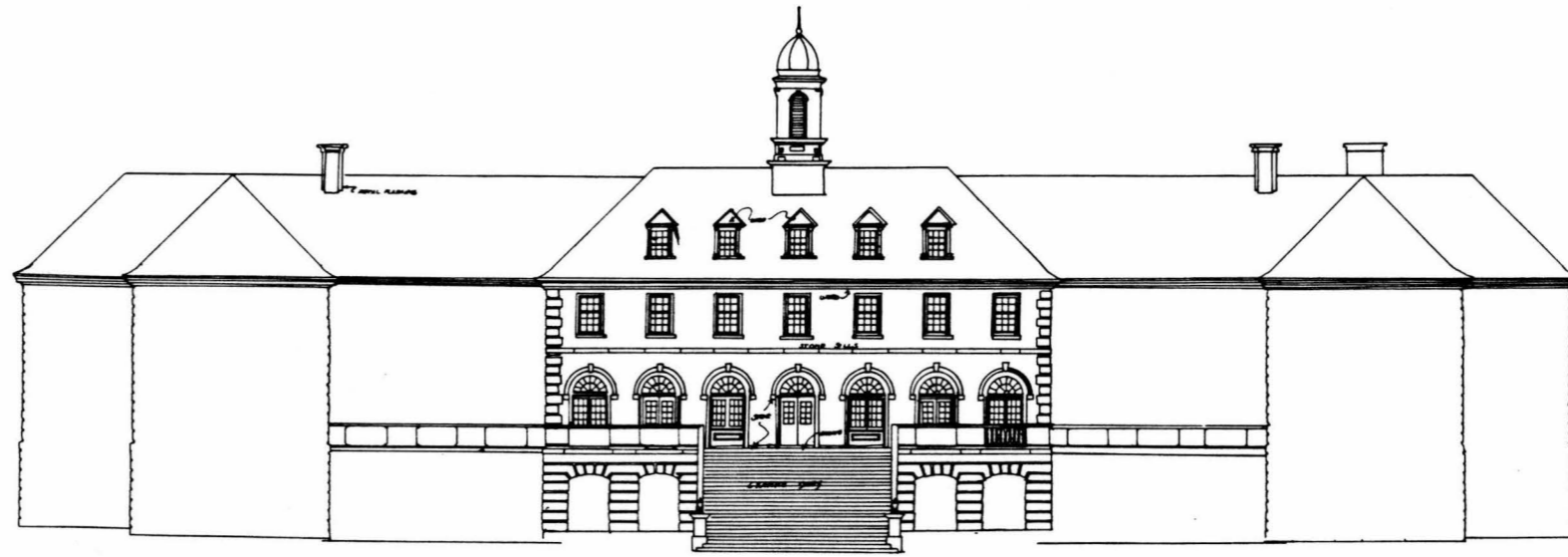

*Squires Student Center*

# *Acknowledgements*



*This Thesis is lovingly dedicated to  
my parents.*

"In all your ways acknowledge  
Him, and He will keep your paths  
straight."

Proverbs 3:6

*Contents*

*Introduction*

*Site*

*Memory*

*Link*

*Path*

*Purpose*

*Conclusion*

*Bibliography*

*Vita*



# Introduction

## INTRODUCTION.

Due to the ever increasing enrollment and growth of Virginia Tech, the need has become evident to the university planners to once again expand the size of the student center. The first portion of the building was built in 1936 and expanded in 1967. Now it is the desire of the college planners not only to expand the building for student activities but for the music and performing arts schools as well.

After receiving the program for this project from the college architects' office I have designed a proposal having taken four concerns into consideration. First, this building must celebrate and demonstrate Virginia Tech's own history and traditions. Second, the building should encourage its function as a link between the town and campus. Third, a large public building of this nature requires a circulation system that is easy to follow and understand, and fourth, that the purposes of the building are clearly met and revealed to the user through the design of the building.



*Squires Student Center Renovation, December 1967*



# *Site*



The site is located in southwest Virginia in Montgomery County in the town of Blacksburg.

The building is an addition and restoration of the Squires Student Center. The gross square footage of the addition is 247,230 s.f. The assignable square footage of the addition is 160,310 square feet. The height of the building will be three stories on the South, or College Avenue side of the building and two stories with a basement on the North, or Mall side of the building.

The building must house the expanded needs of student activities and programs as well as the Music and Performing Arts schools.

Adjacent to the site is U.S. Route 460 Business, a thoroughfare which will continue to be one of the major vehicular routes to the site. The location of the existing Squires building and the proposed new addition gives this facility excellent accessibility.

### Physiographic Features

Rolling hills, slopes of open fields adjacent to the existing building vary from nearly flat to over 20 percent. The area picked for the expansion is the lawn between Squires and Henderson Hall.

Soil bearing capacity in the building vicinity is generally adequate for regular spread footings.

Vegetation is open lawns with mature trees and other landscape planting, preserving many of these mature trees is desired.

Ground and surface water does not seem to be a problem. There is no surface water prevalent on the site. The university's experience gained in the construction of buildings adjacent to the building site indicates that ground water maladies do not exist.

A 100 year flood plan lies immediately south of Squires.

The site of Squires as it looked in 1898. Site is in the foreground of this picture.

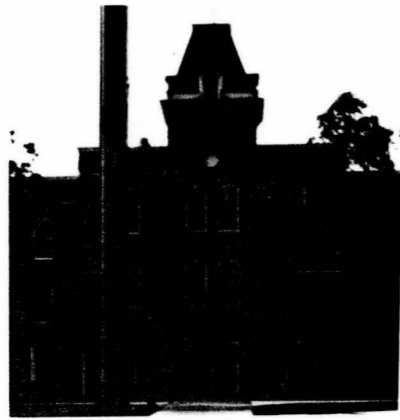

LANE HALL



PLAZA



NEWMAN LIBRARY

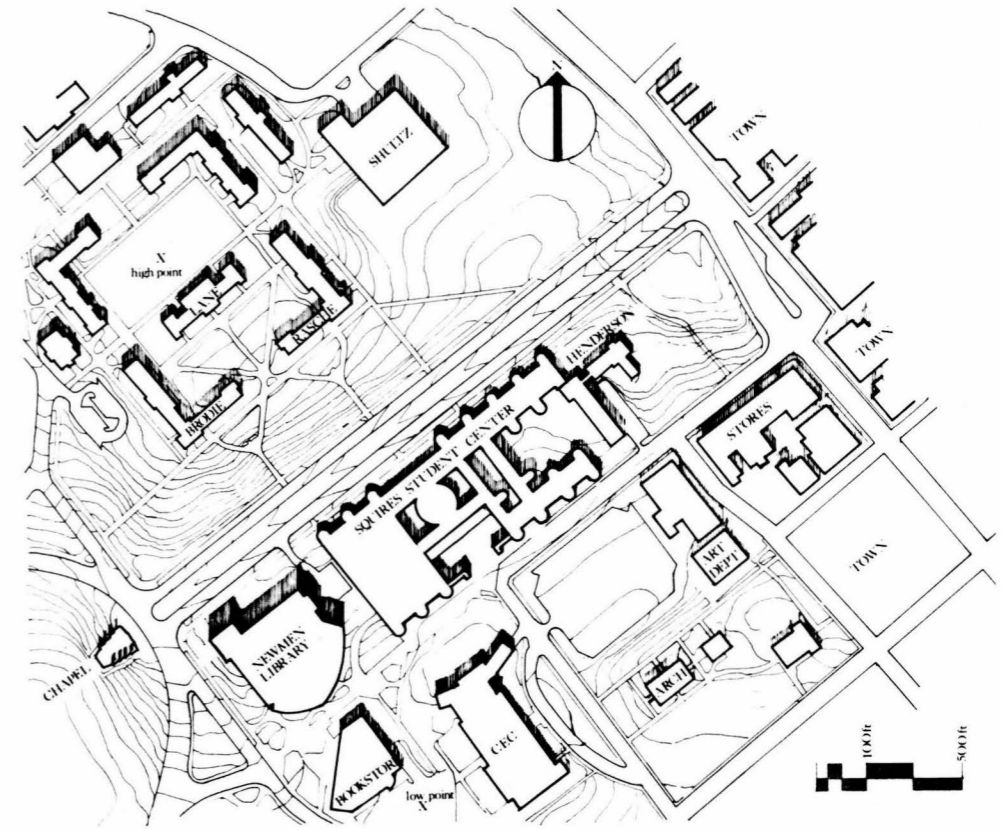

The Site.

Number of Floors 3.

Given State Site Area 5.130 acres = 223,480 square feet.



BOOK STORE



CEC

# Memory

Louis Kahn:

"That is why it is good for the mind to go back to the beginning, because the beginning of any established activity is its most wonderful moment."

Buildings hold memory. There are very large and costly buildings that are preserved and maintained exclusively for this purpose of holding memory.

There is something in the human spirit that asks a person to walk back through his or her past and think and remember. And every year the alumni return in droves.

Why is it important for a collegiate building like Squires to hold memory? For the very reason that it is a collegiate building where thousands come and go during their very unique and temporary stay in college.

Universities have an exclusive right, even a responsibility, to hold onto their past through their architecture. But there is more to memory than mere personal nostalgia. A university must hold on to its history and its tradition. Its past success demands to be spelled out in the architecture of its buildings. Its power and credibility are revealed by its built spaces.

"In 1904 Squires, a Junior at North Carolina College of Agriculture and Mechanical Arts, had been suspended along with his entire class for some group or class action considered as insubordination by the authorities. When he found that he would not be readmitted to the college, he wrote to Dr. McBryde, president of VPI, asking about the possibilities of completing his education "at your school."

He had been quite frank about his situation at North Carolina A and M, neither defending nor excusing his conduct.

McBryde contacted President Winton of North Carolina A and M, who gave his approval of Squires' admission to VPI. Following the receipt of this approval, McBryde sent Squires a telegram notifying him that VPI would accept him as a student.

Squires entered school at once and from that day forward was one of VPI's most loyal and devoted sons. Upon his death he had left VPI a considerable legacy, a larger part of which Burruss used to start construction on the student activities building."

Kinnear







"Thomas C. Lile was appointed Director of the Squires Student Center, as the renovated Squires Hall was called. This structure, known to thousands of alumni as the Student Activities Building, or the SAB, was closed late in 1966 for extensive renovation and enlargement into a building three times the size of the original structure. Undoubtedly, the spirit of John Squires, who had been received by VPI in one of his darkest hours."



Kinnear

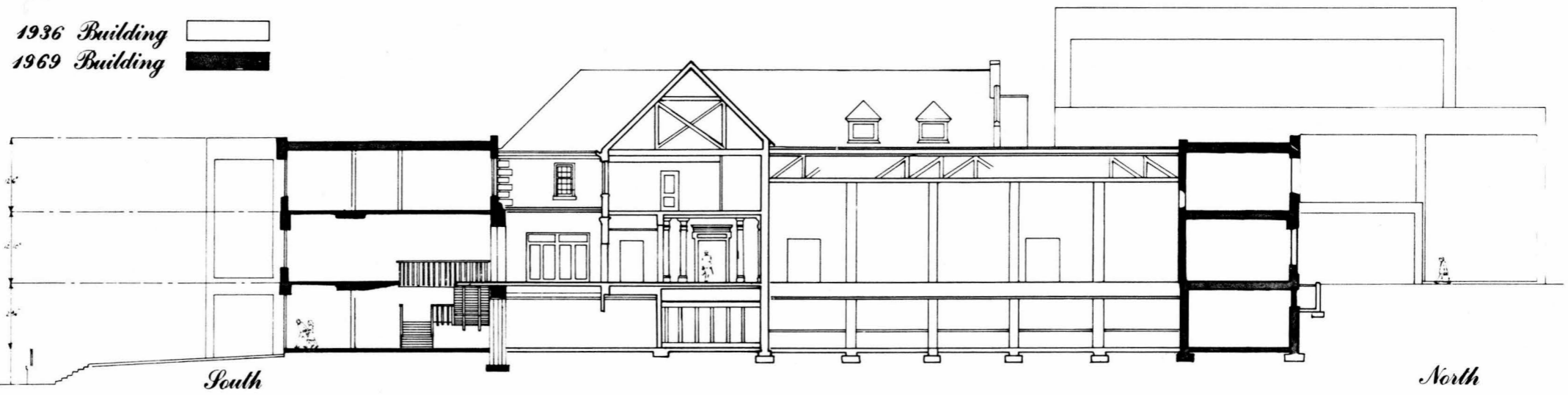

Squires Student Center, January 1969

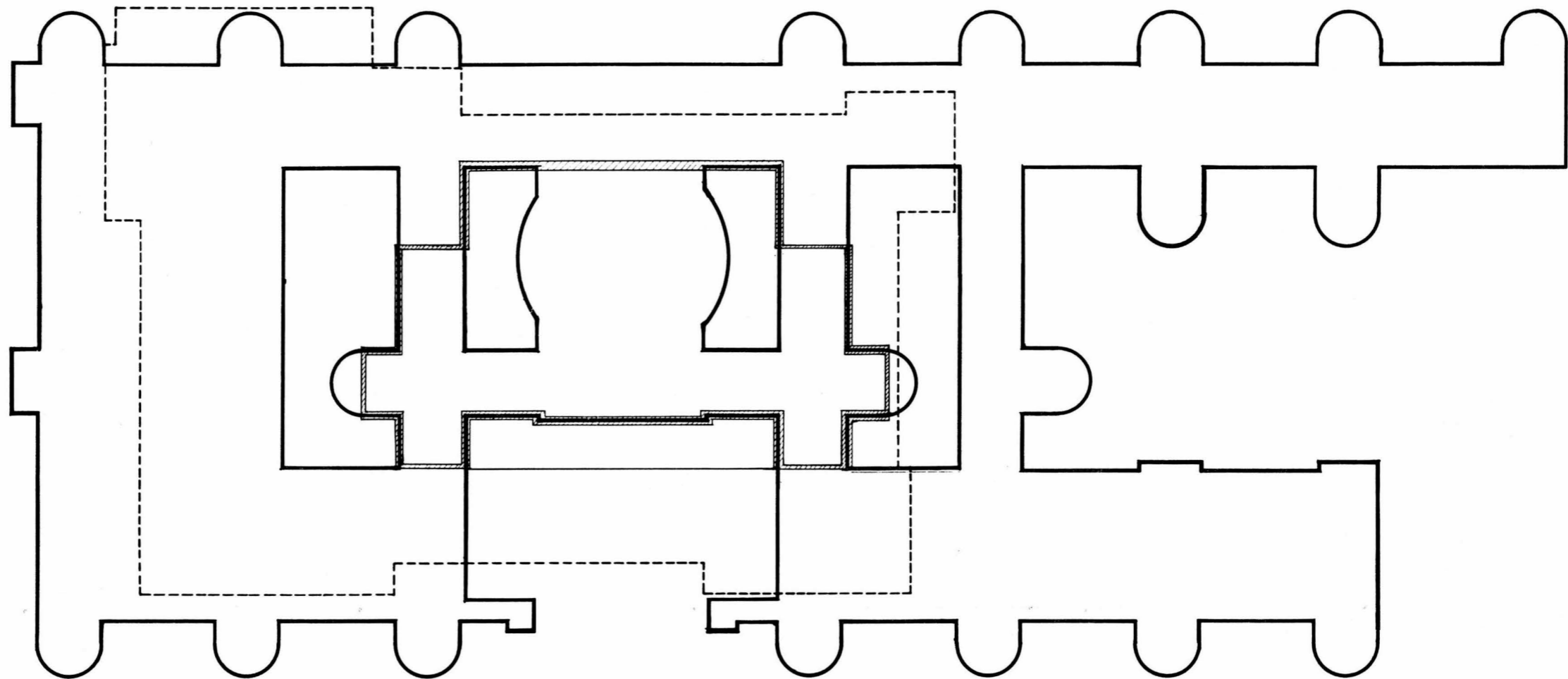

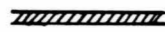
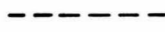

<b>1936</b>	
<b>1969</b>	
<b>1988</b>	

*The expansion will consist of two wings extending from the site of the present building into Henderson Lawn creating a park-like area and preserving the lawn and some mature trees.*

*The entire 1967 building will be demolished and replaced by new wings with courtyards between them. For circulation and natural light, the additions will be three stories high.*

# Link



*The architecture of the campus and town buildings surrounding the proposed building site are different in age, aesthetics and quality. The most predominant element around the new building is the major pedestrian walkway that links the college to the downtown business district. This walkway is adjacent to Squires on the east.*



**LINK.**

*The Squires building is a link by bringing the past to the present, the college to the town, the students to each other. As a meeting place, restaurant or information center it is ideally located because it lies directly between town and campus.*

*The town of Blacksburg has made itself very attractive to university and student business. It is full of restaurants, barber shops, specialty shops, movie theaters, donut shops, and the post office.*

*The new building must also relate to the present buildings particularly Alumni Hall; for this reason red brick arranged in a Flemish bonding will be used on the exterior of the building as it is on the Alumni Hall and the original 1936 Squires Hall.*

*Though Squires is a campus building it belongs more to the other town buildings on College Avenue. Because of its location, this is more of a reason for it to agree with those three-story brick buildings by resembling them rather than the traditional Hokie stone facades used on the library and bookstore.*



*"Architects will have to begin to look at the larger picture, not just the individual building. A building has to relate to other buildings, and buildings have to relate to streets and squares. If we begin to look at how the individual building fits into its setting, we can begin to develop a unified civic architecture that we lack today."*

*I. M. Pei*

*The Corner of College Avenue and Main, 1936*

*January 1988*

# Path



The plaza and College Avenue are located on the South side of the building and can be described as the gateway between town and campus due to the fact that it is the main pedestrian route.

Squires also lies directly between the town and the majority of the academic buildings; thus there is a constant concentration of students cutting through the building throughout the day, particularly during cold weather.

The more formal entrance to the school from town is on the North side of the building. It is a mall and, though it does not have the pedestrian use like College Avenue and the plaza, it is a major vehicle route as well as the site of a major bus stop in front of Squires.

Squires as a building is a strong part of the life of the campus. Even if it was not a student center it would still become a part of the experience of the people on campus simply because of its location.

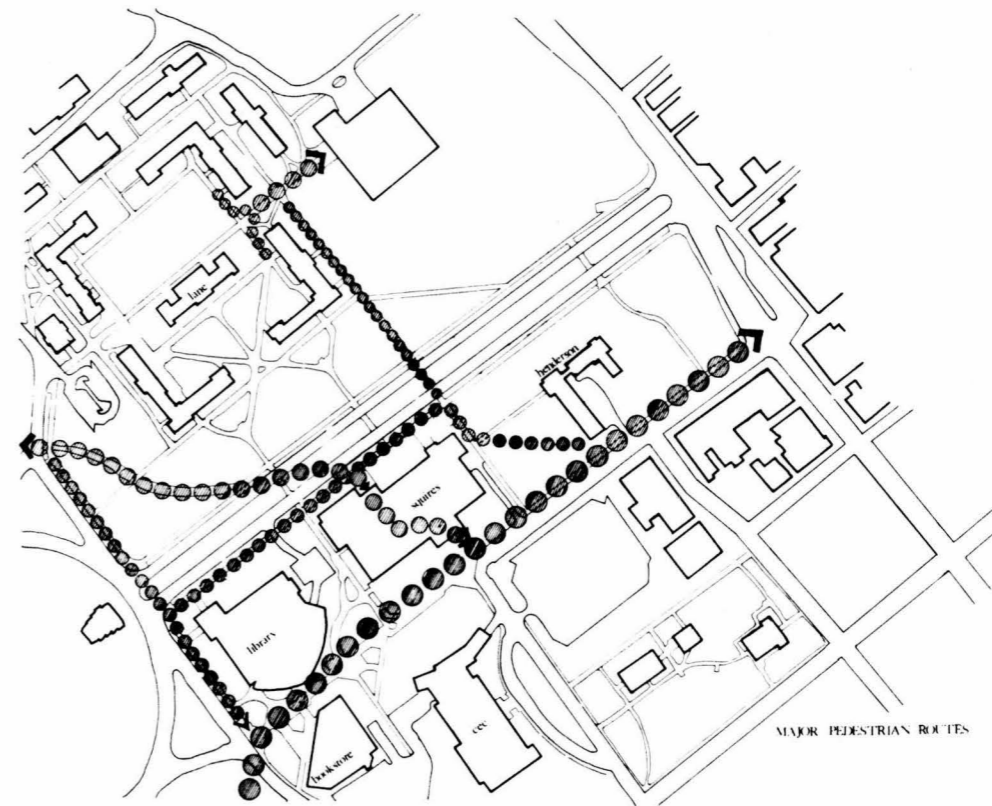

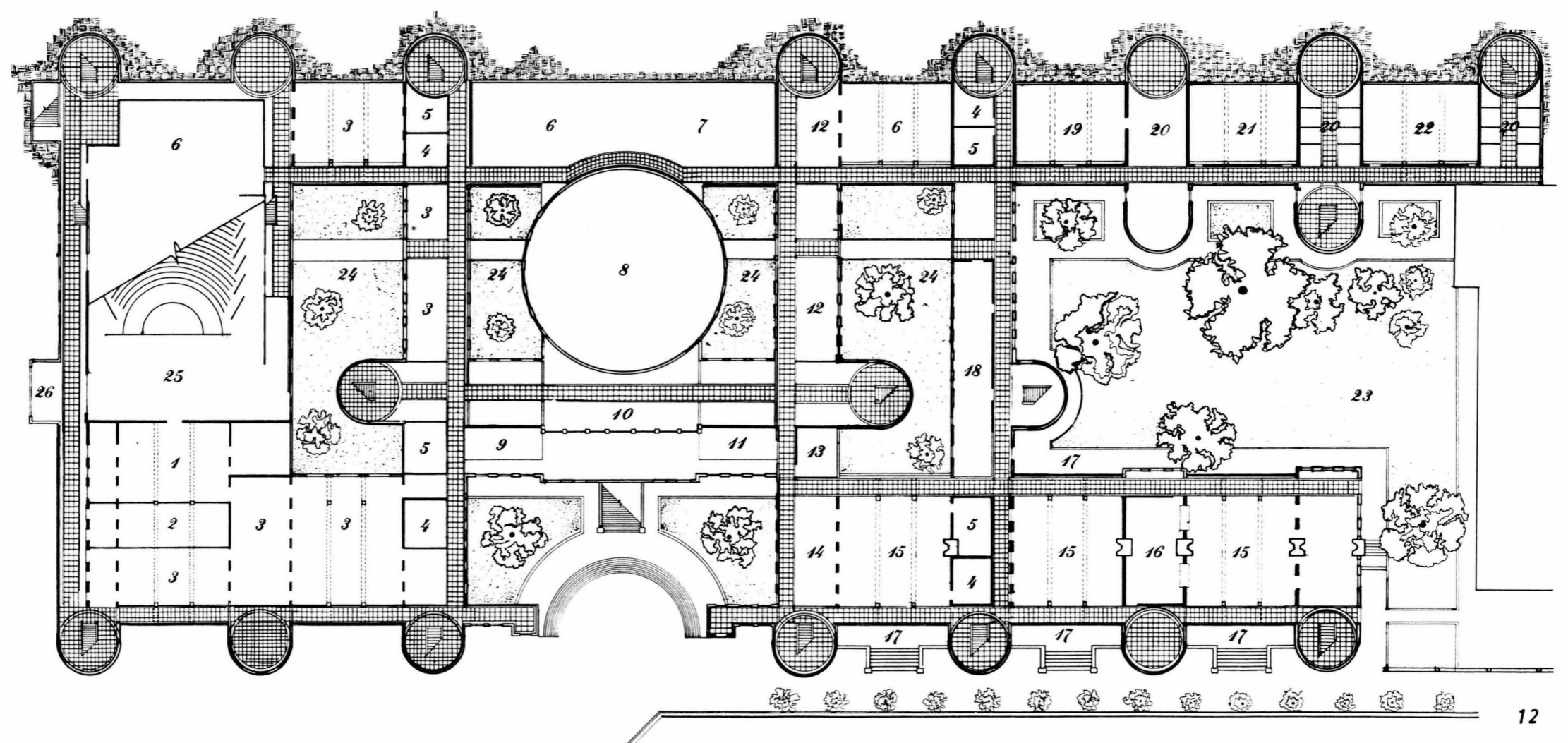

# Purpose

## PURPOSE.

The floor plan of the new Squires is designed to allow several routes through the building from the North to the South. Each route exposes several of the activities housed in the building, and thus the building becomes its own information center revealing the many functions, organizations, and activities housed there to every pedestrian who passes through.

The west side route connects the theater lobby, the theater, the back stage and scenic shop, the crafts shop and store, the outdoor recreation equipment station, the recreational rooms, and performing arts classrooms along its pathway. Thus by simply taking this route pedestrians discover all of these activities within the building. There are three other routes with similar experiences of discovery.

Presently all the key student organizations, offices and activities, are hidden away from public view.

The third floor is the least traveled level and therefore is reserved for activities and organizations requiring a quieter area.



Drill Field, Winter 1905



Williams Hall Lock in 1968



Student 1940



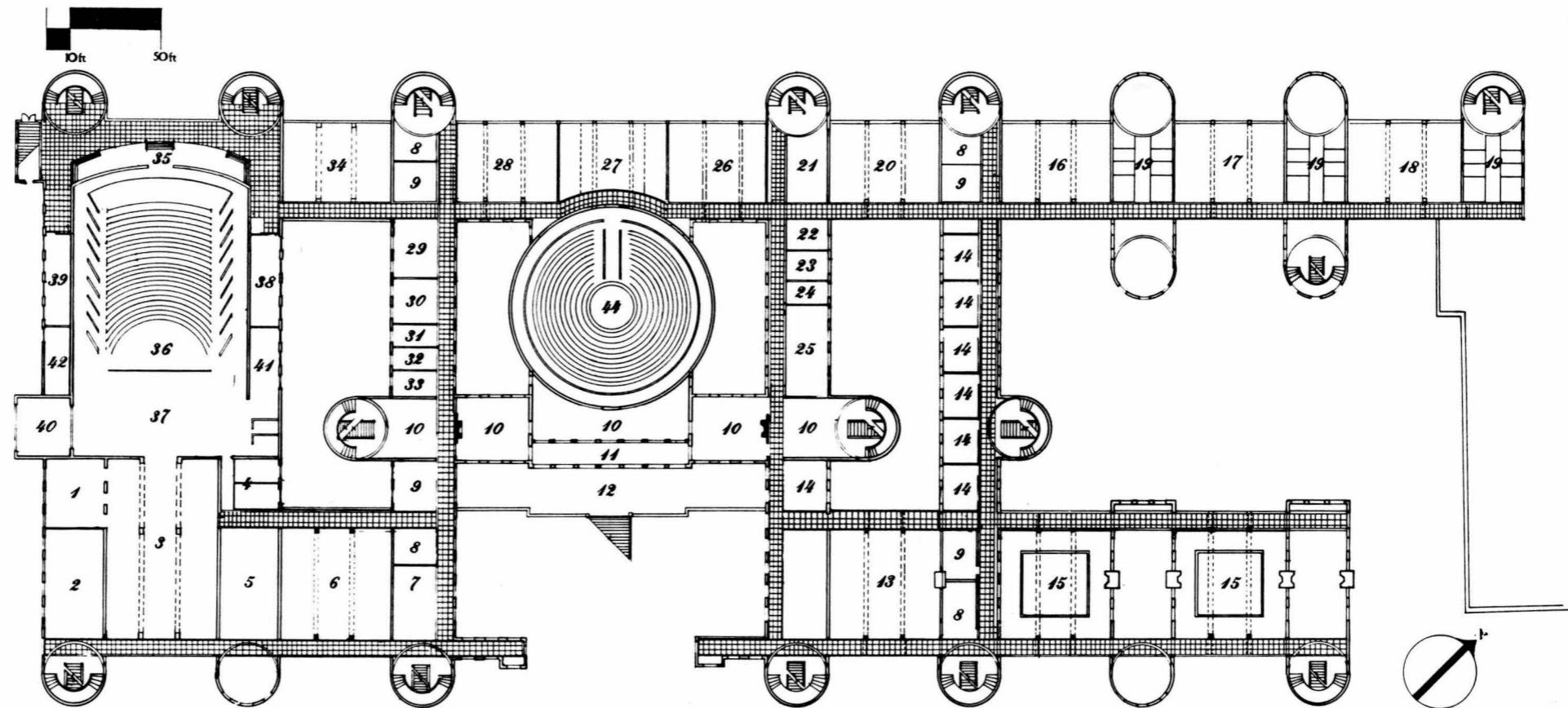

Second Floor

- 1. Theater Classrooms
- 2. Theater Storage
- 3. Laboratory Theater
- 4. Dressing Rooms
- 5. Theater Offices
- 6. Rehearsal Room
- 7. Theater Offices
- 8. Men's Room
- 9. Women's Room
- 10. Lobby

- 11. Porch Covered
- 12. Outside Porch
- 13. Rehearsal Room
- 14. Meeting Rooms 10-15 Seating
- 15. Upper Level to Dining
- 16. Upper Recital
- 17. Upper Rehearsal
- 18. New Virginian's Practice Room
- 19. Practice Rooms
- 20. Student Publication Office

- 21. Offices
- 22. Amateur Radio Association
- 23. YMCA
- 24. Other Organizations
- 25. Other Organizations
- 26. WUVT Radio
- 27. Lobby Bus Waiting
- 28. Student Organizational Workroom
- 29. SGA Office
- 30. Honor System

- 31. Resident Hall Federation
- 32. IFC BSA Office
- 33. Graduate Student Office
- 34. Virginia Tech Union
- 35. Theater Lobby
- 36. Theater Stage
- 37. Men's Room
- 38. Ladies Room
- 39. Delivery Entrance
- 40. Senate Hall

Due to the size of Squires it was necessary to open up the building with four court yard spaces in order to allow natural light to enter the central rooms and hallways of the building. These court yards also eliminate the many problems with water drainage that occur with most expanses of flat roofs.

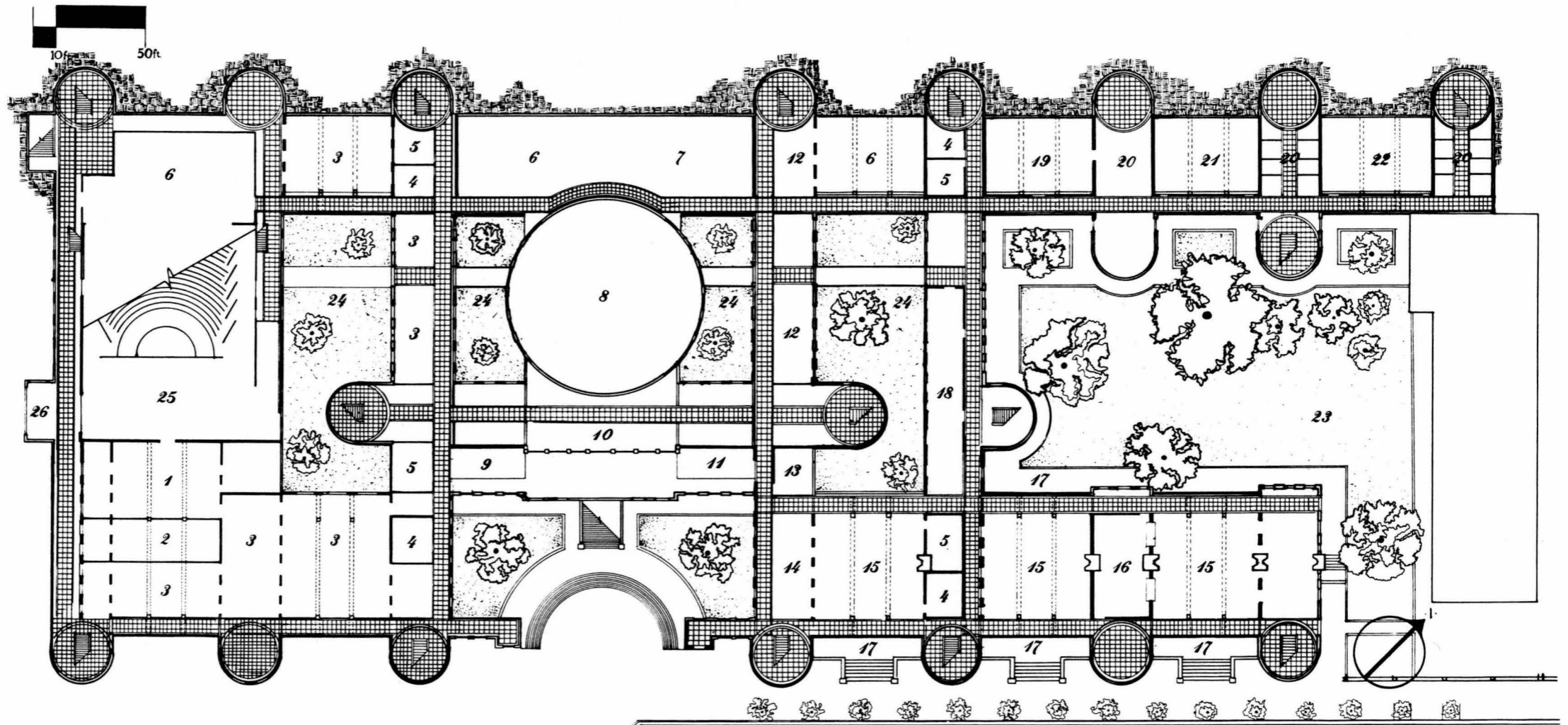

*First Floor*

- 1. Arts and Crafts
- 2. Outdoor Recreation Equipment
- 3. Recreation
- 4. Men's Room
- 5. Women's Room
- 6. Storage
- 7. Maintenance

- 8. Ballroom
- 9. Telephones
- 10. Lobby
- 11. TV Room
- 12. Art Gallery
- 13. Convenience Sales
- 14. Snack Bar Lobby

- 15. Dining Room
- 16. Kitchen
- 17. Porch
- 18. Credit Union
- 19. Recital Room
- 20. Practice Rooms
- 21. Rehearsal Room
- 22. New Virginian's Practice Room
- 23. Common
- 24. Courtyard
- 25. Scene Shop
- 26. Delivery Entrance

*THE GARDEN AND THE ROOM.*

*"In doing a memorial I started with a room and a garden. That was all I had. Why did I choose a room and a garden as a point of departure? Because the garden is a personal gathering of nature, and the room is the beginning of architecture."*

*Louis Kahn*

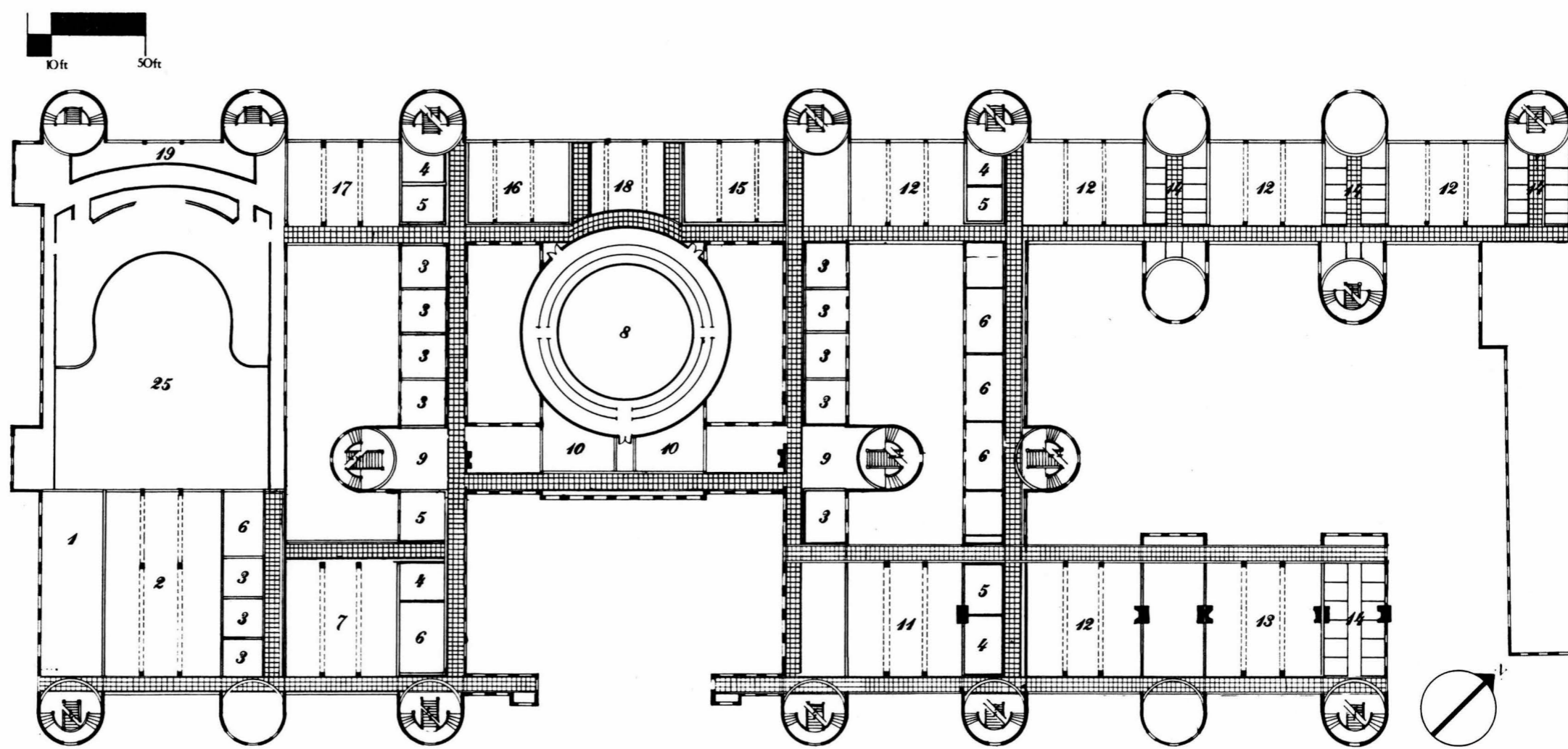

Third Floor

- |                                  |                                 |
|----------------------------------|---------------------------------|
| 1. Theater Classrooms            | 13. Rehearsal Space             |
| 2. Laboratory Theater Upper Part | 14. Practice Rooms              |
| 3. Meeting Rooms                 | 15. Senate Room                 |
| 4. Men's Room                    | 16. Meeting Room                |
| 5. Women's Room                  | 17. Office Space                |
| 6. Office                        | 18. Upper Part of Lobby         |
| 7. Upper Rehearsal               | 19. Upper Part of Theater Lobby |
| 8. Senate Hall                   | 20. Theater                     |
| 9. Lobby                         |                                 |
| 10. Meeting Rooms                |                                 |
| 11. Administration               |                                 |
| 12. Exhibition Space             |                                 |

THE PLAN.

"I think that a plan is a society of rooms. A real plan is one in which rooms have spoken to each other. When you see a plan, you can say that it is the structure of the spaces in their light."

Louis Kahn



ROTC's water fight, Spring 1968

# Conclusion



Matt 29:30

*"And why are you anxious about clothing? Observe how the lilies of the field grow; they do not toil nor do they spin, Yet I say to you that even Solomon in all his glory did not clothe himself like one of these."*

MATT 6:29-30

**"BEAUTY IS THE PROMISE OF FUNCTION."**

*Solomon in all his glory is, therefore, not arrayed as the lily of the field. Solomon's array is the result of the instinctive effort of incompleteness to pass itself for complete. It is pretension. When Solomon shall have appreciated nature and himself, he will reduce his household, and apart his harness, not to pretension, but for performance. The lily is arrayed in heavenly beauty because it is organized, both in shape and color, to dose the germ of future lilies with atmospheric and solar influence."*

Horatio Greenough.

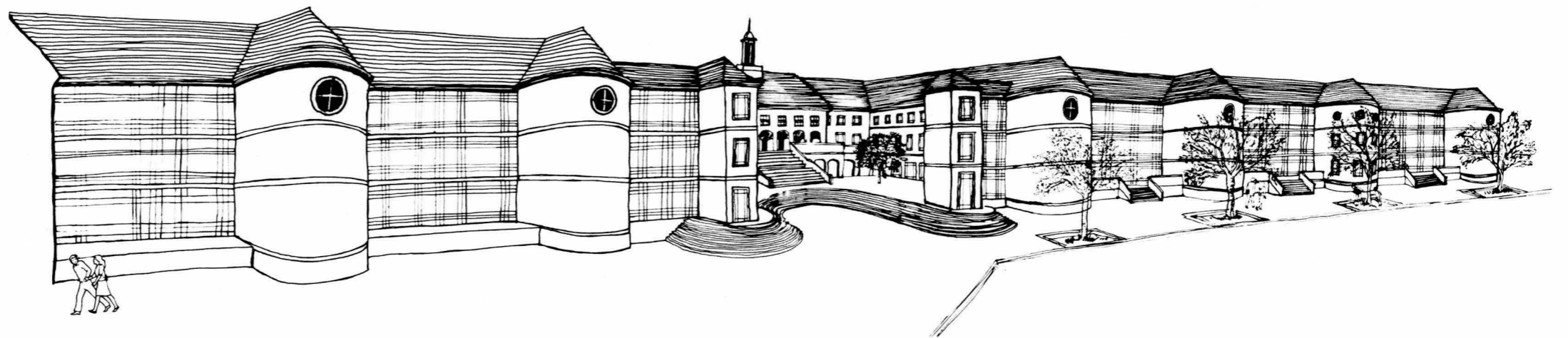

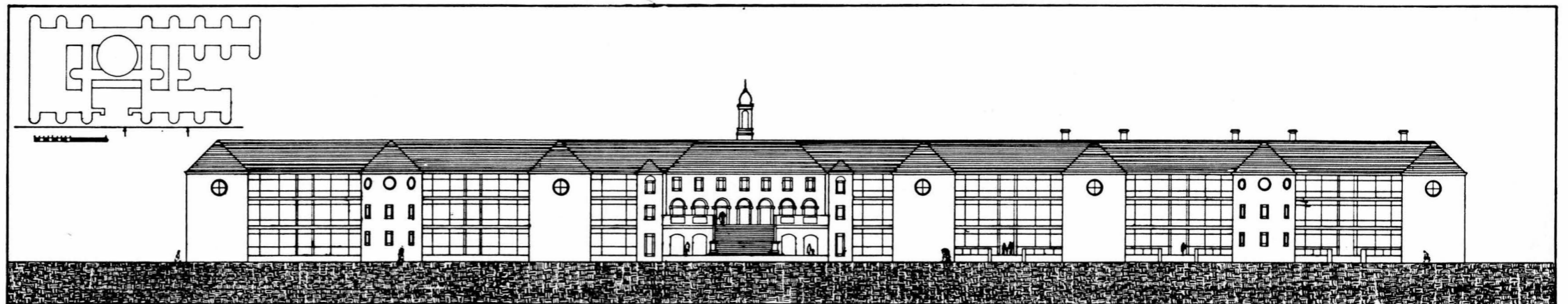
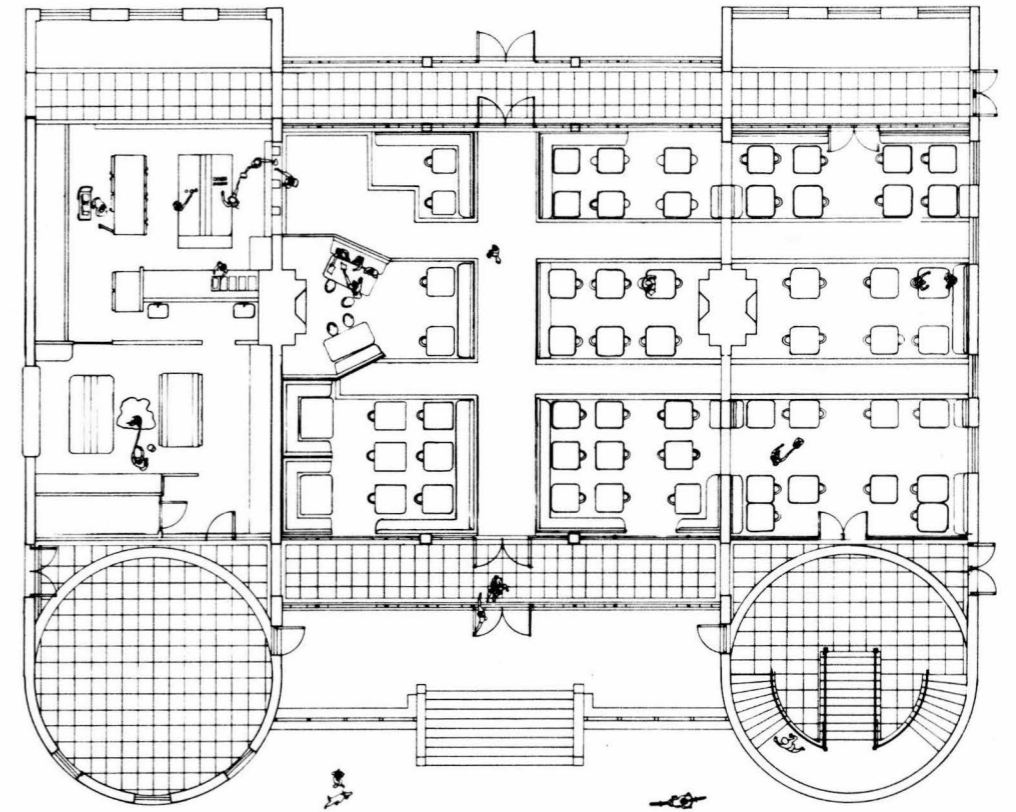
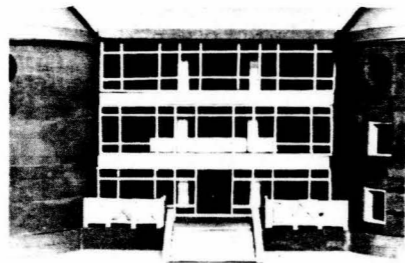

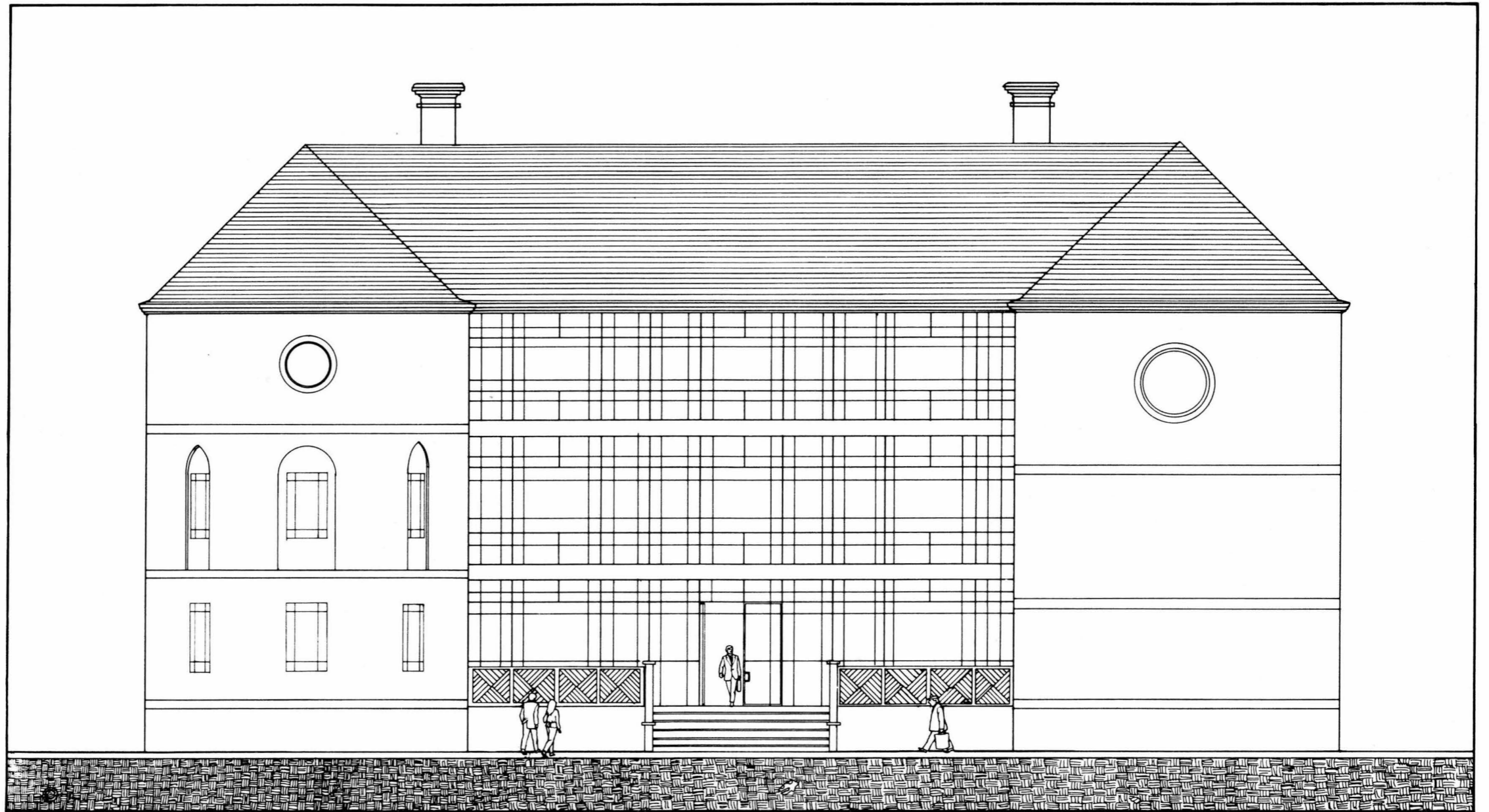

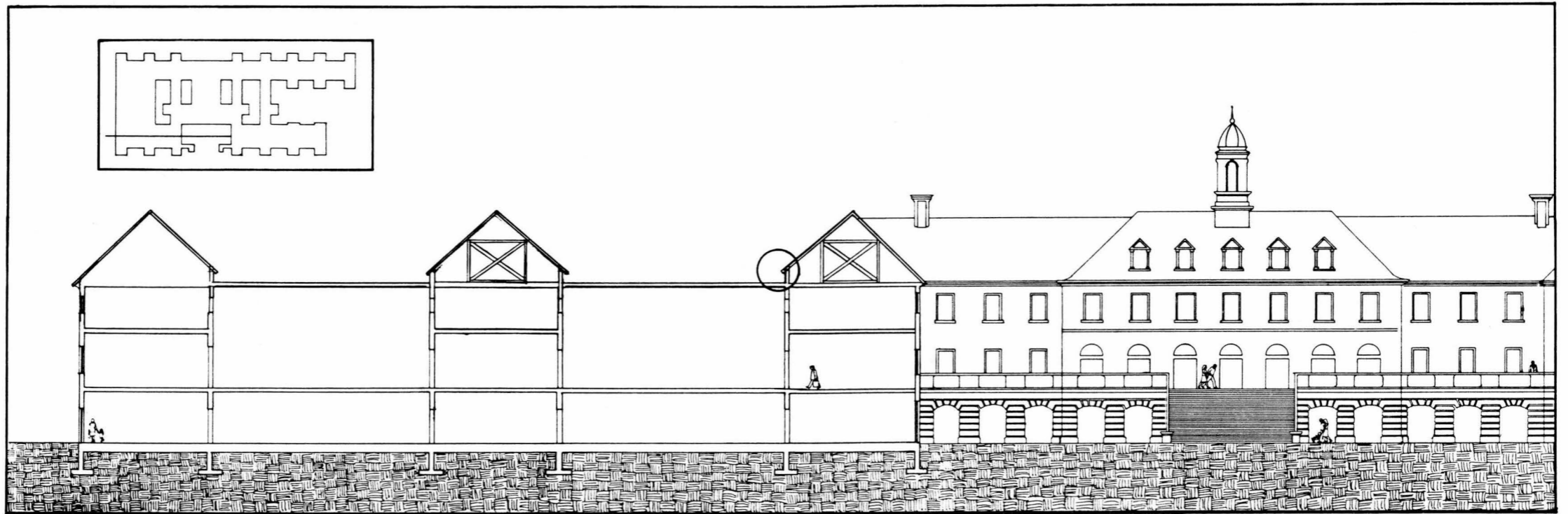

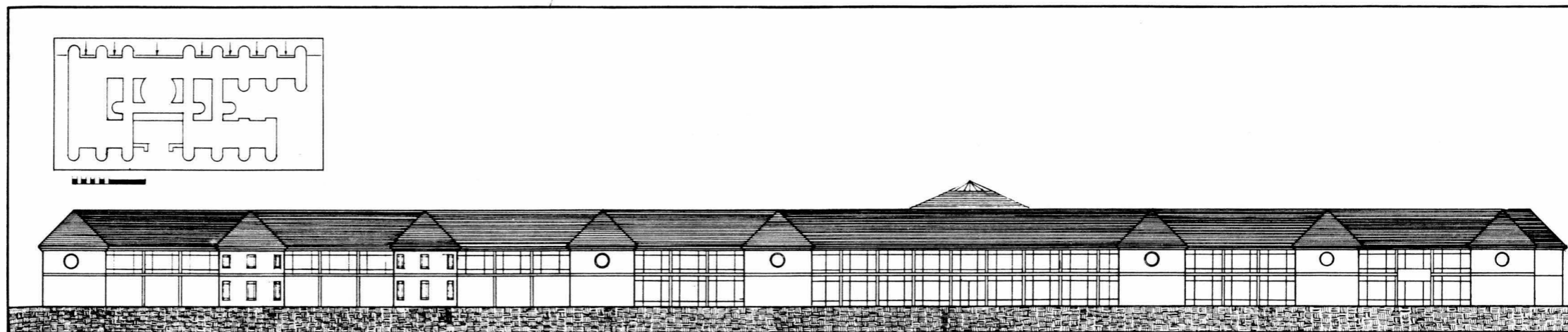

SECTION EAST TO WEST

1. Meeting Room
2. Offices
3. Credit Union
4. Meeting Room
5. Offices

6. Art Gallery
7. Ball Room
8. Senate Hall
9. Meeting Room
10. Office
11. Recreation Room
12. Storage
13. Theater

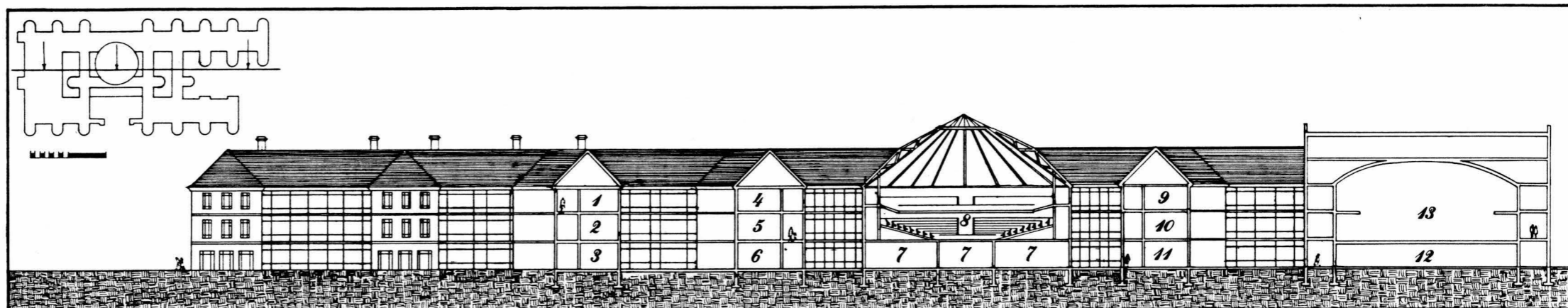



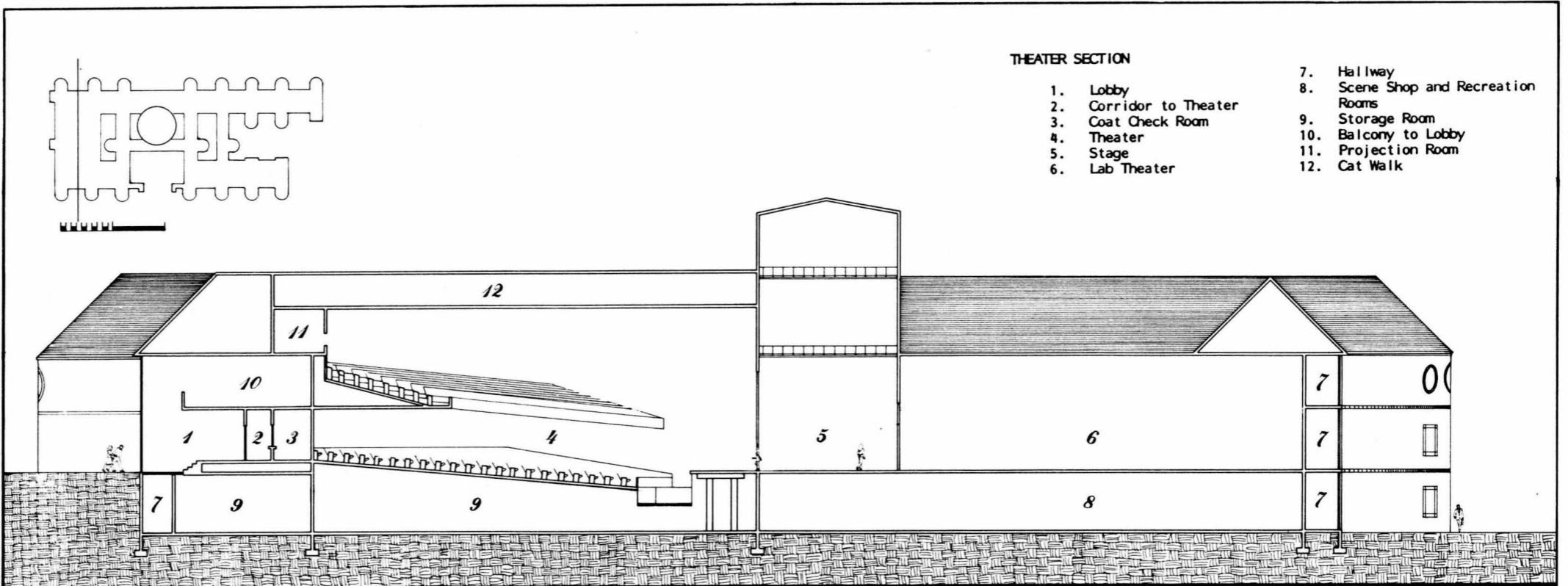
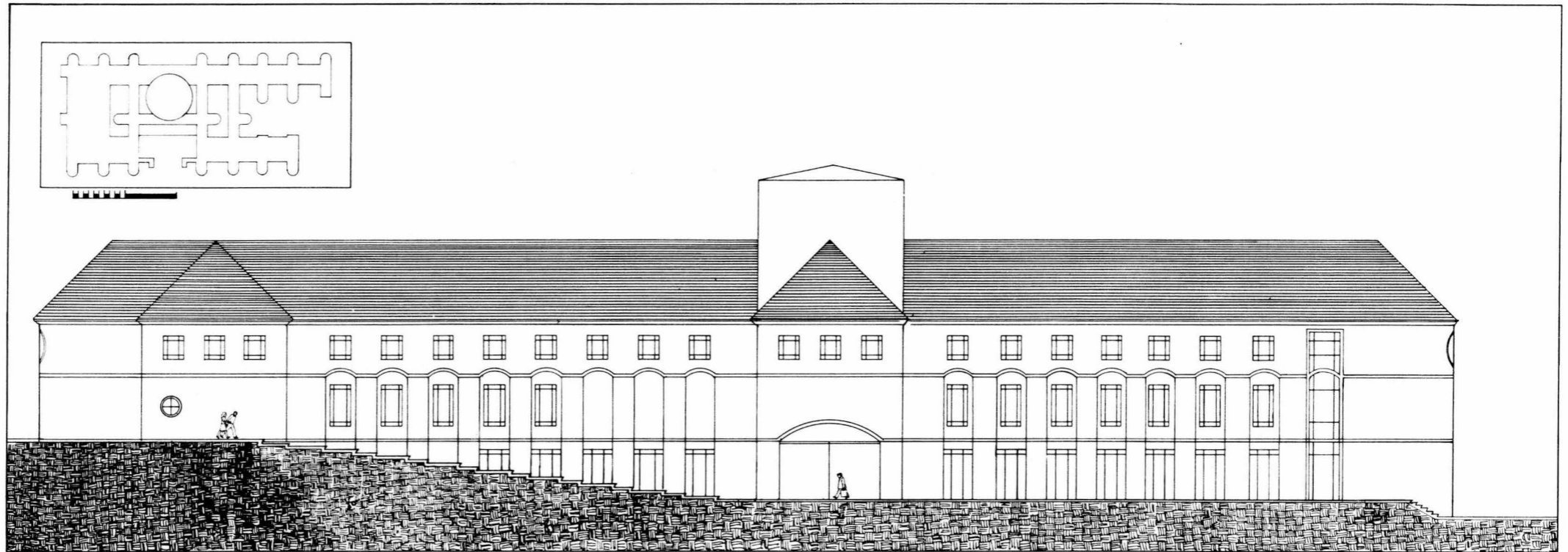

SECTION THROUGH SENATE HALL

- 1. Upper Bus Lobby
- 2. Lower Bus Lobby
- 3. Mechanical
- 4. Senate Hall

- 5. Ball Room
- 6. Hallway
- 7. Museum and Information Center
- 8. Lower Lobby

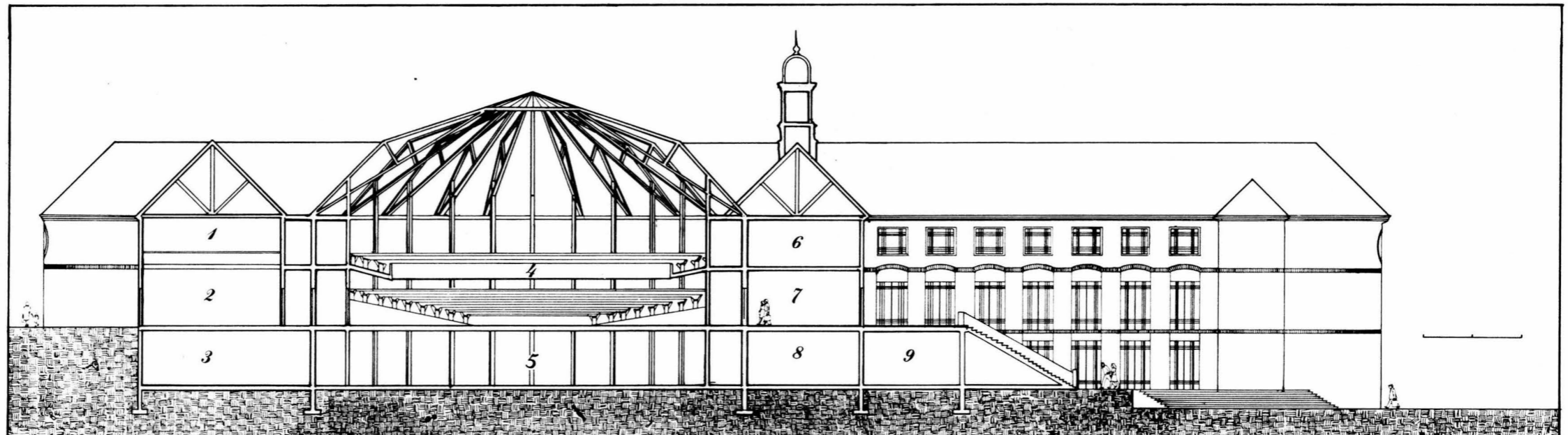

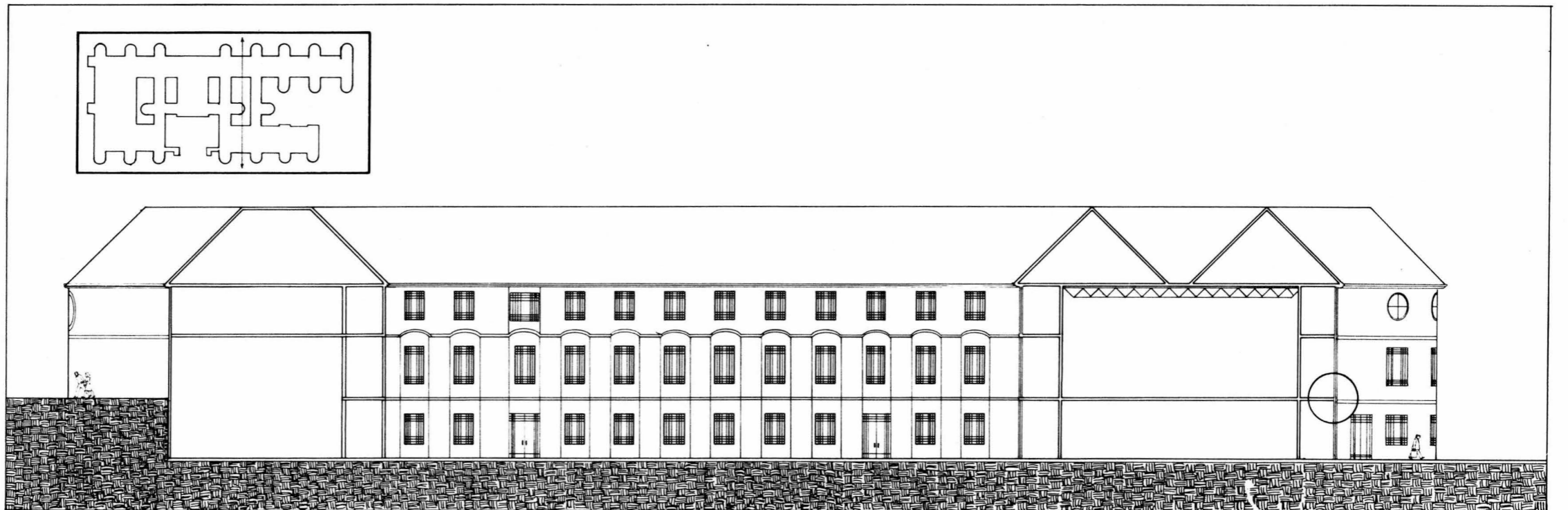

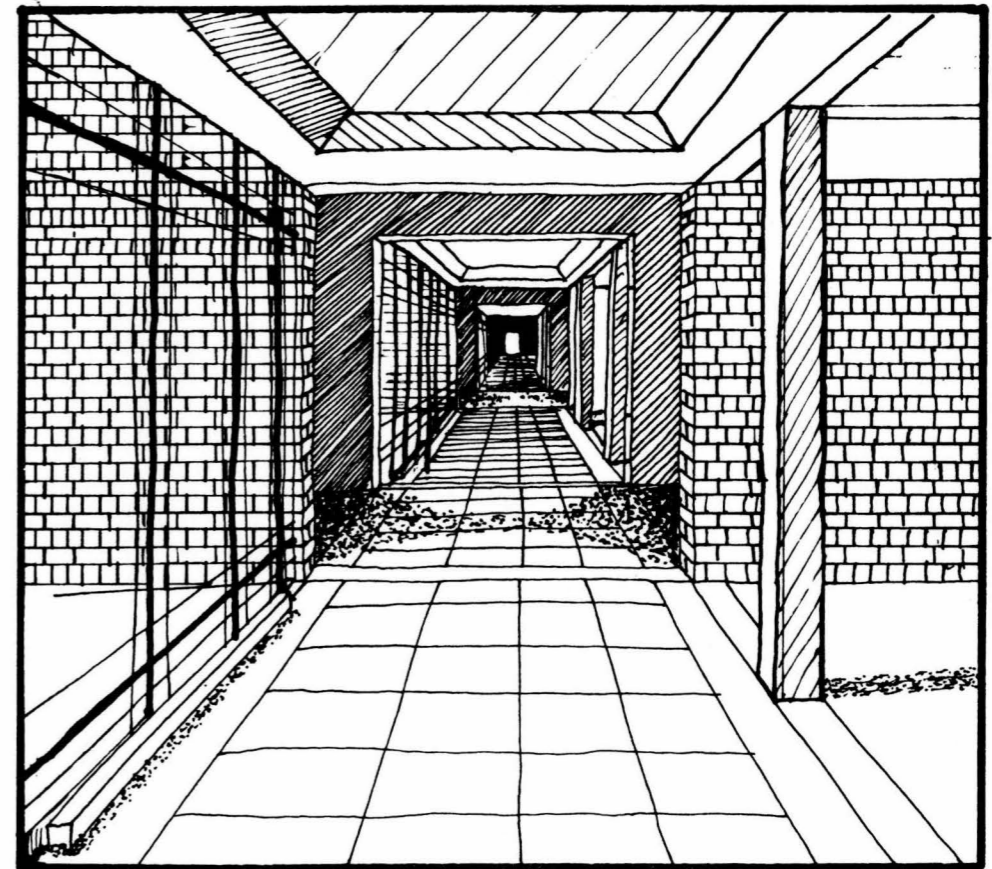
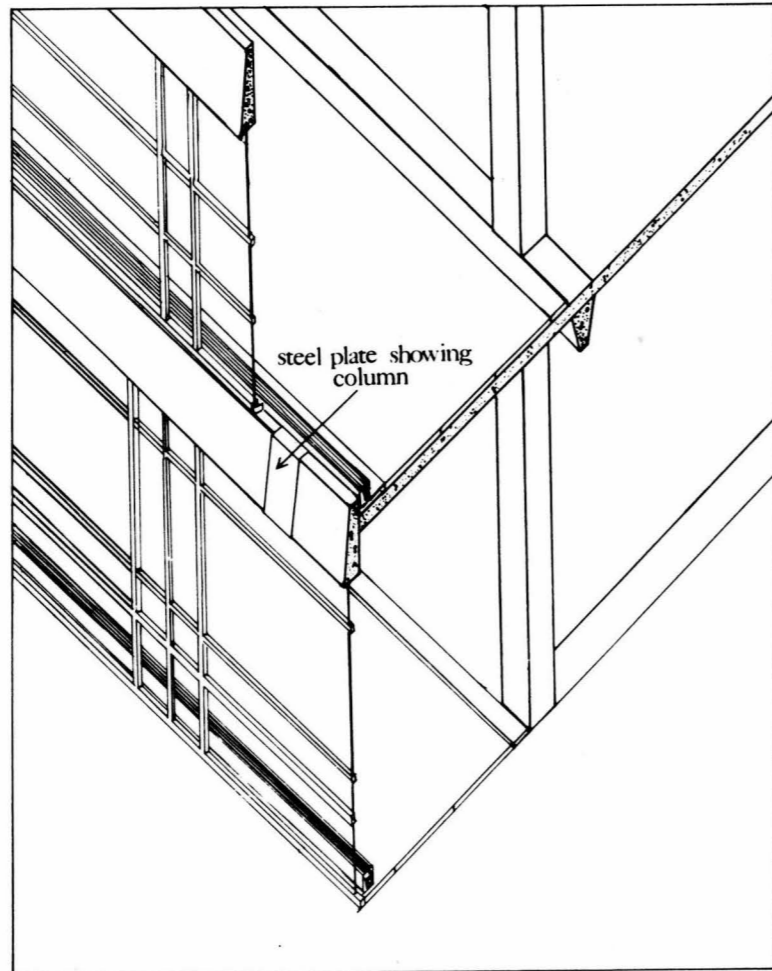

**STRUCTURE.**

*"Structure is the giver of light. When I choose an order of structure that calls for column alongside column, it presents a rhythm of no light, light, no light, light, no light. A vault, a dome, is also a choice of character of light."*

Louis Kahn

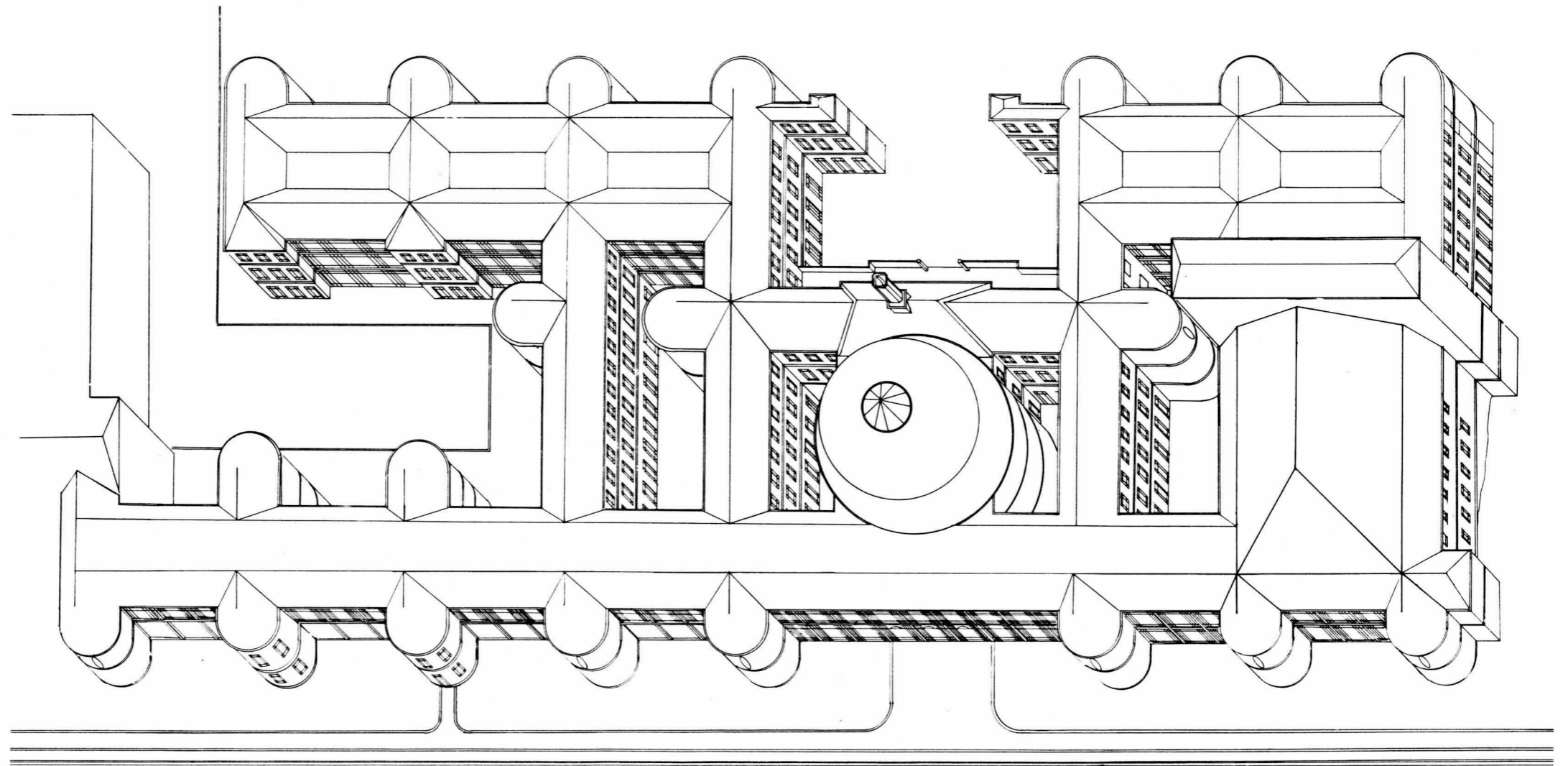

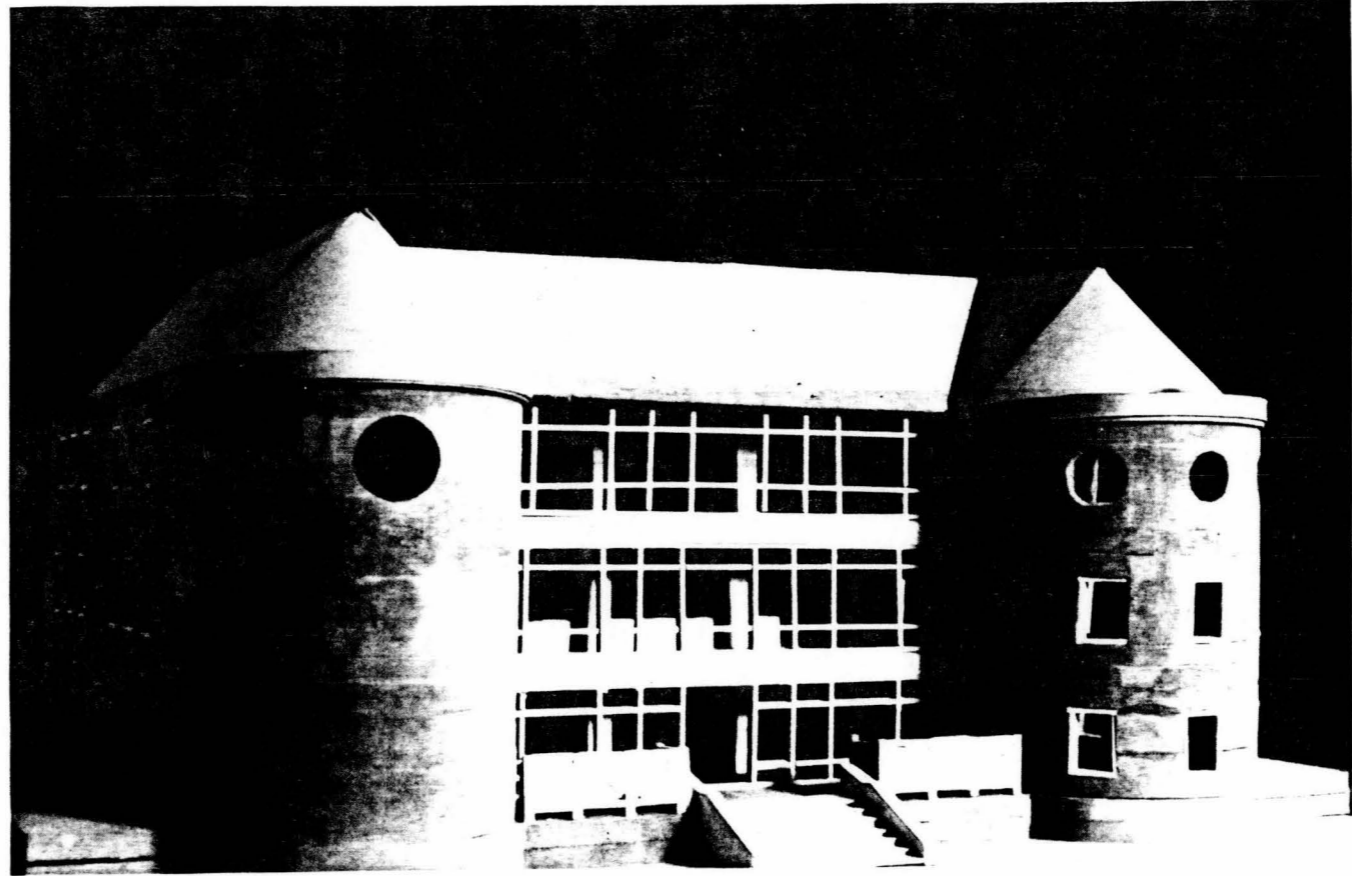

# *Bibliography*

Horatio Greenough, *FORM AND FUNCTION*. University of California Press. Berkeley. 1957.

Duncan Lyle Kinnear, *THE FIRST 100 YEARS. 'A History of Virginia Polytechnic Institute and State University.'* Virginia Polytechnic Institute. Educational Foundation, Inc. Blacksburg, Virginia. 1972.

God, *NEW AMERICAN STANDARD BIBLE*. Thomas Nelson Publishers. Nashville. 1977.

John Lobell, *BETWEEN SCIENCE AND LIGHT 'Spirit in the Architecture of Louis I. Kahn.'* Shambhala, Boulder. 1979.

Pierson, *AMERICAN BUILDINGS AND THEIR ARCHITECTS*. Doubleday Company, Inc., New York. 1970.



*First Ring Dance, 1934*

**The vita has been removed from  
the scanned document**