

156
5

STABLES

by

KAREN LYNN GAMMON

Thesis submitted to the Faculty of the
Virginia Polytechnic Institute and State University
in partial fulfillment of the requirements for the degree of

MASTER OF ARCHITECTURE

Approved by:

Hans Christian Rott, Chairman

Salahuddin Choudhury

Michael J. O'Brien

September, 1990
Blacksburg, Virginia

TABLE OF CONTENTS

Beginning	2
Middle	7
End	18

To

For whose guidance, patience, friendship, and
encouragement I have tremendous gratitude
and whose wisdom and enthusiasm for
architecture will always be both inspiration
and motivation throughout my career.

STABLES

(Abstract)

The following is a proposal for stables to be located in Galesburg, Illinois. It will house a maximum of twenty four standard bred horses, which are to be raced at local race tracks.

EMERGENCE

Excellently scented, the horses,
Excellently proportioned. This is
Just how they are made and no other
Fashion would suit a horse quite so well.

Their smooth forms push back tangling
grass,
Reveal leafy new precisions for
Our limited sight. The undefined
Birds had chirped uneasily, but now

Exact notes herald around the forms
Of horses. What we like about them
Is that this is how they come, in peace.
What ennobles us is this watching

Of their precisions. Their affection
For the epiphanal landscape.



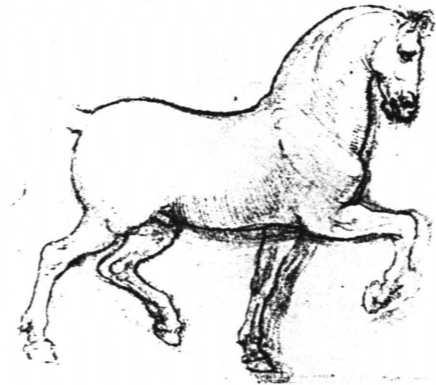
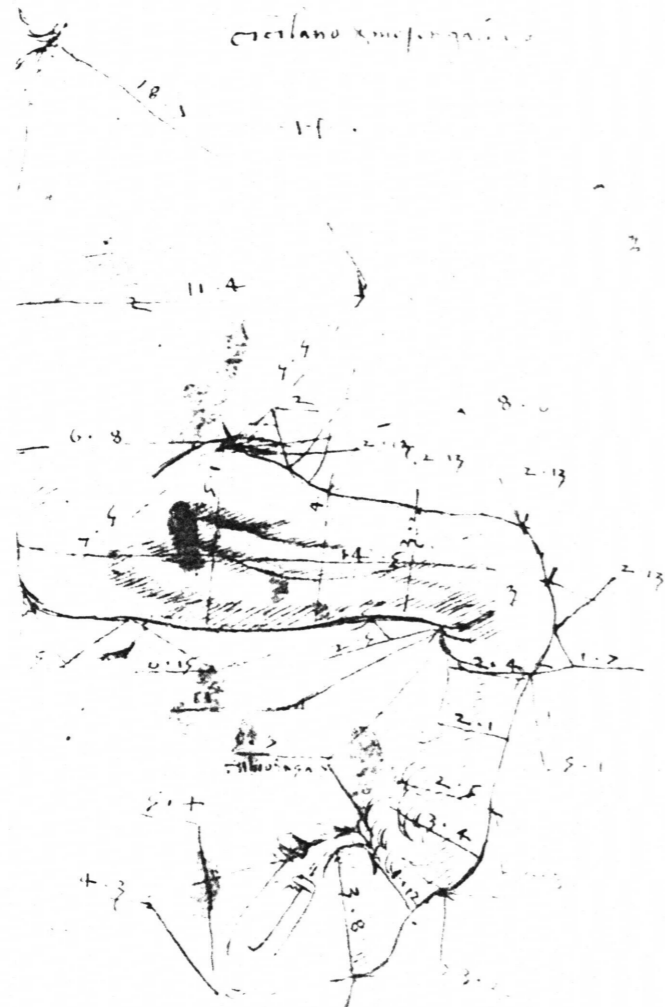

" Let proportion be found not only in numbers and measures, but also in sounds, weights, times, and positions, and whatever force there is."

Leonardo da Vinci

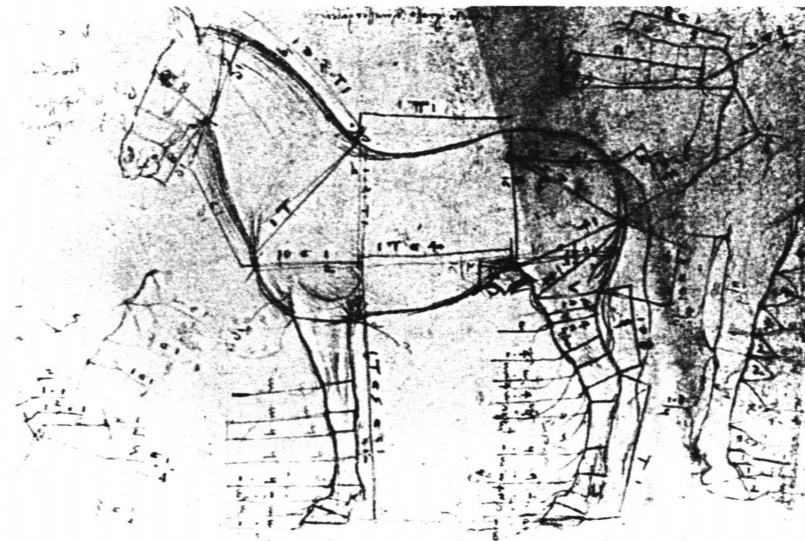

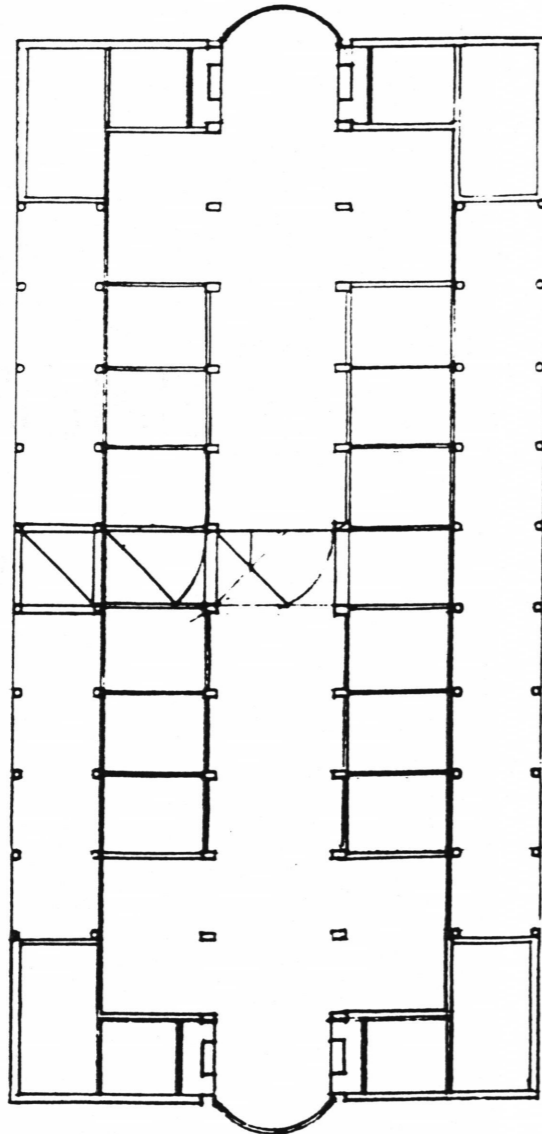

" . . . the innate ability of man to appreciate the harmonies of proportion underlying God's design of nature which would provide the means by which the architect could design beautiful buildings."

Alberti

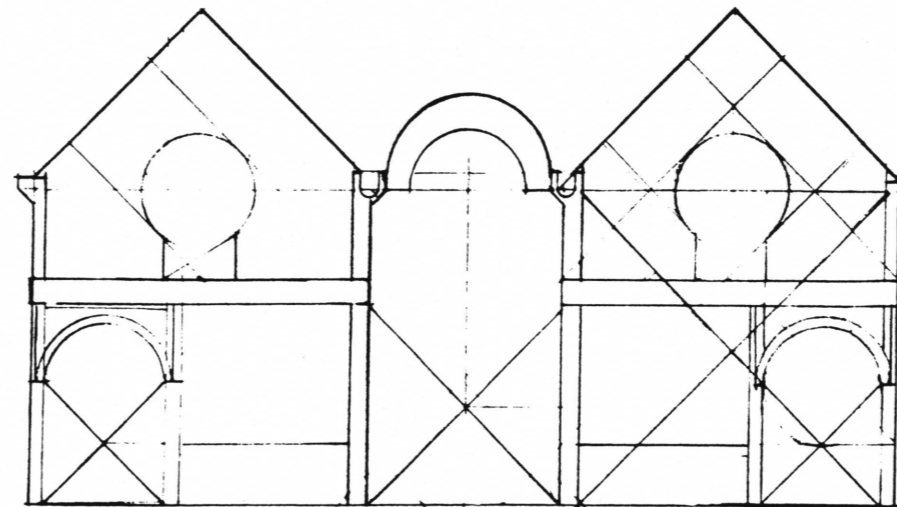

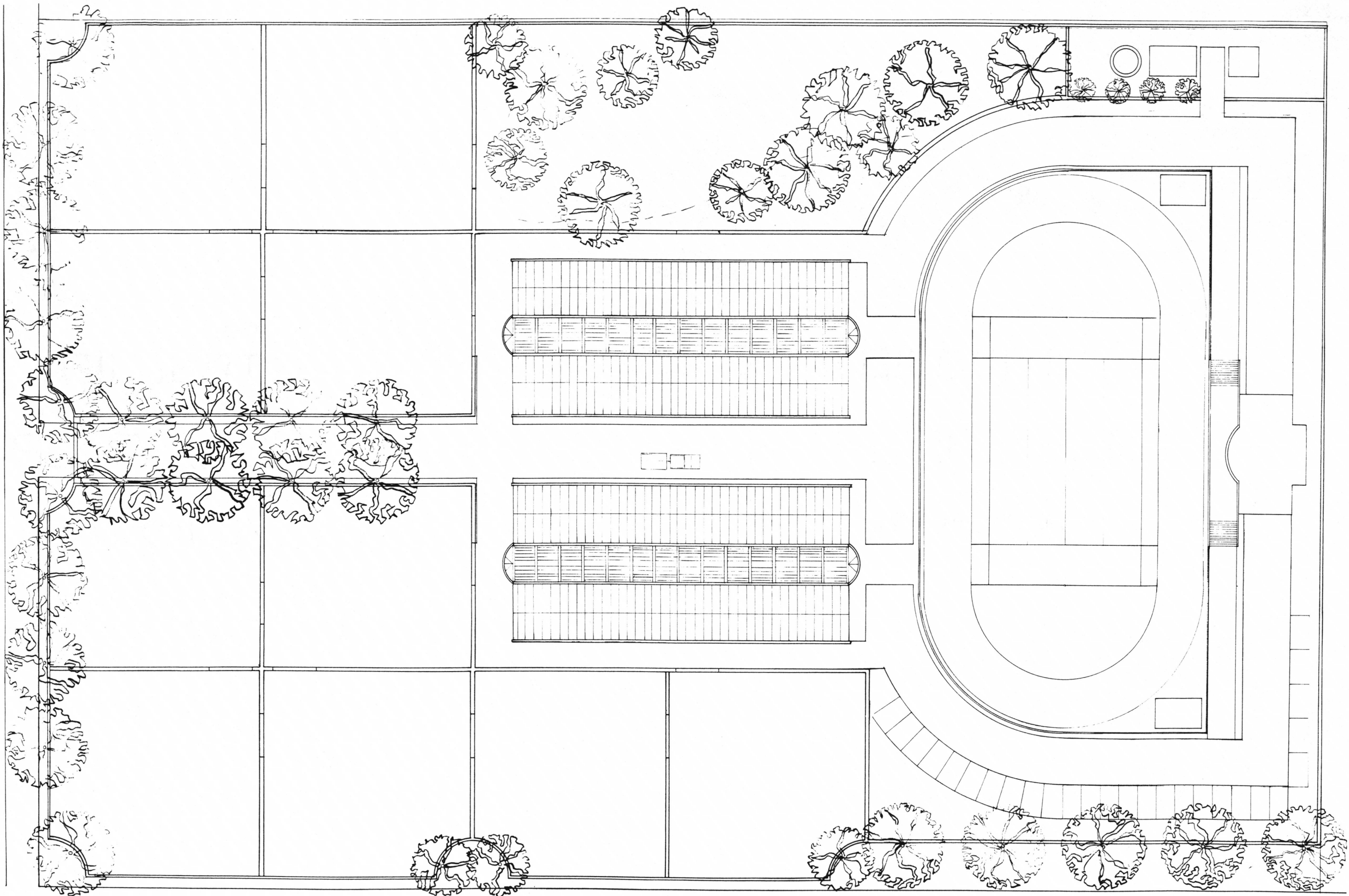

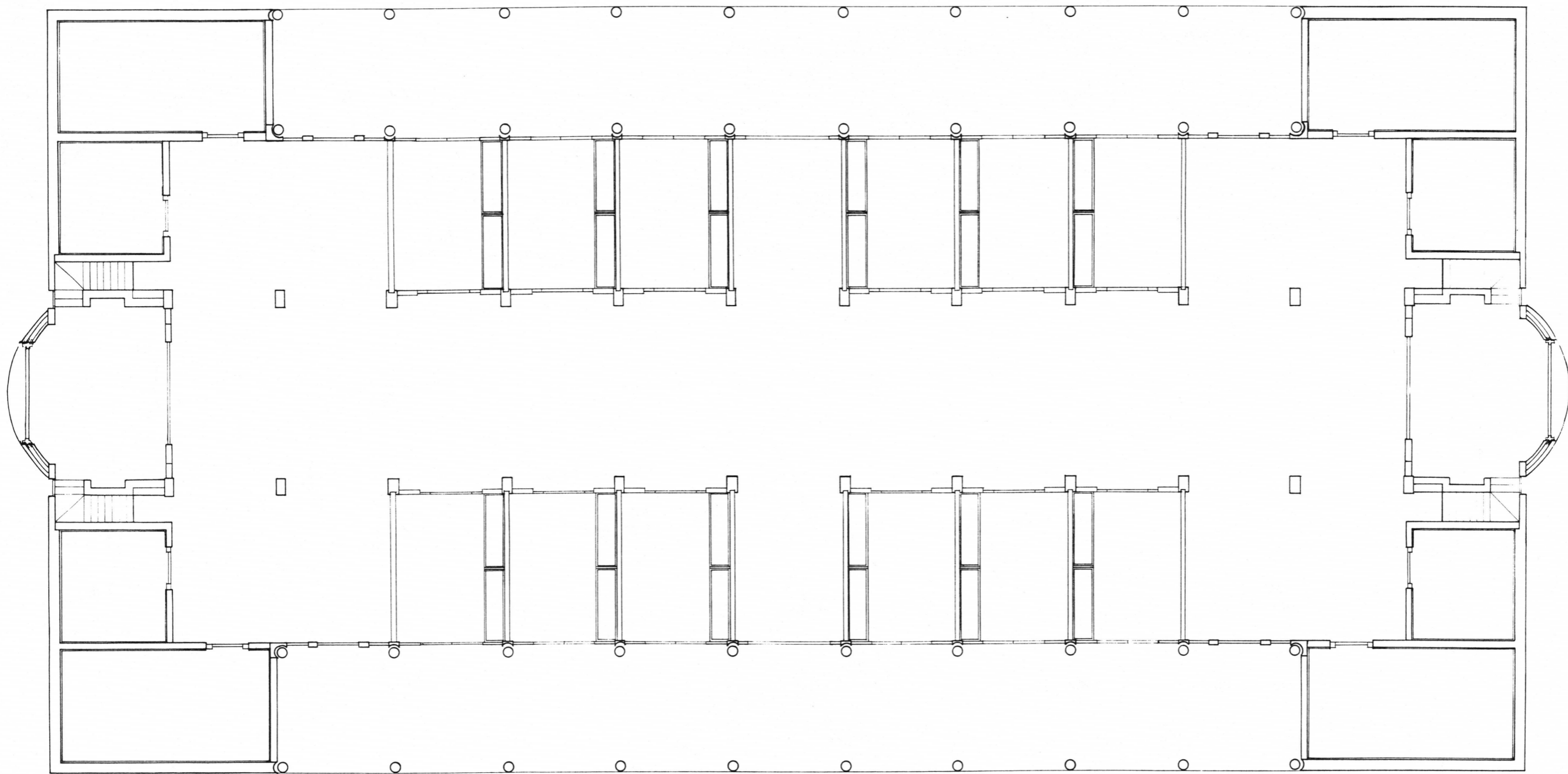

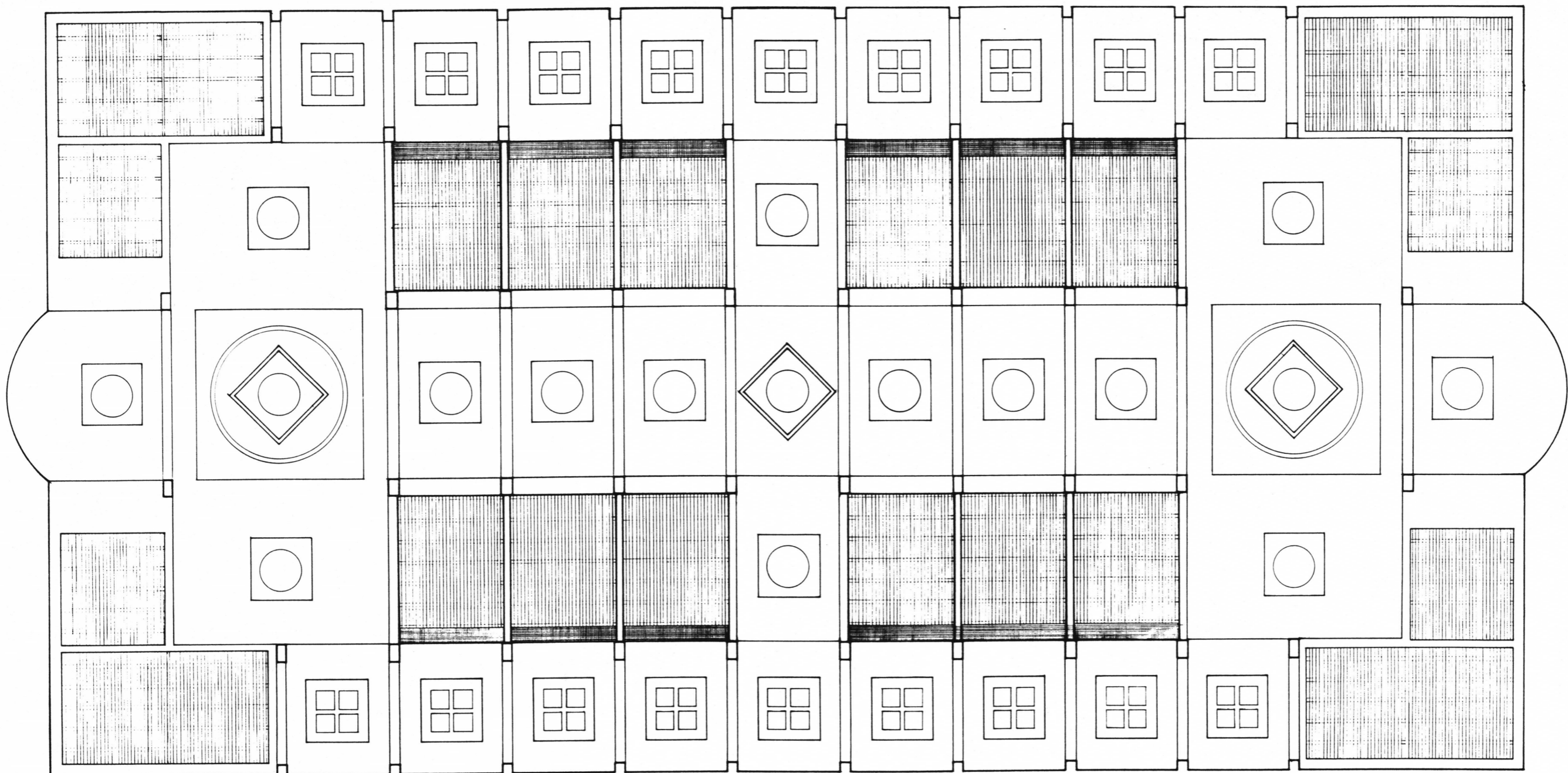

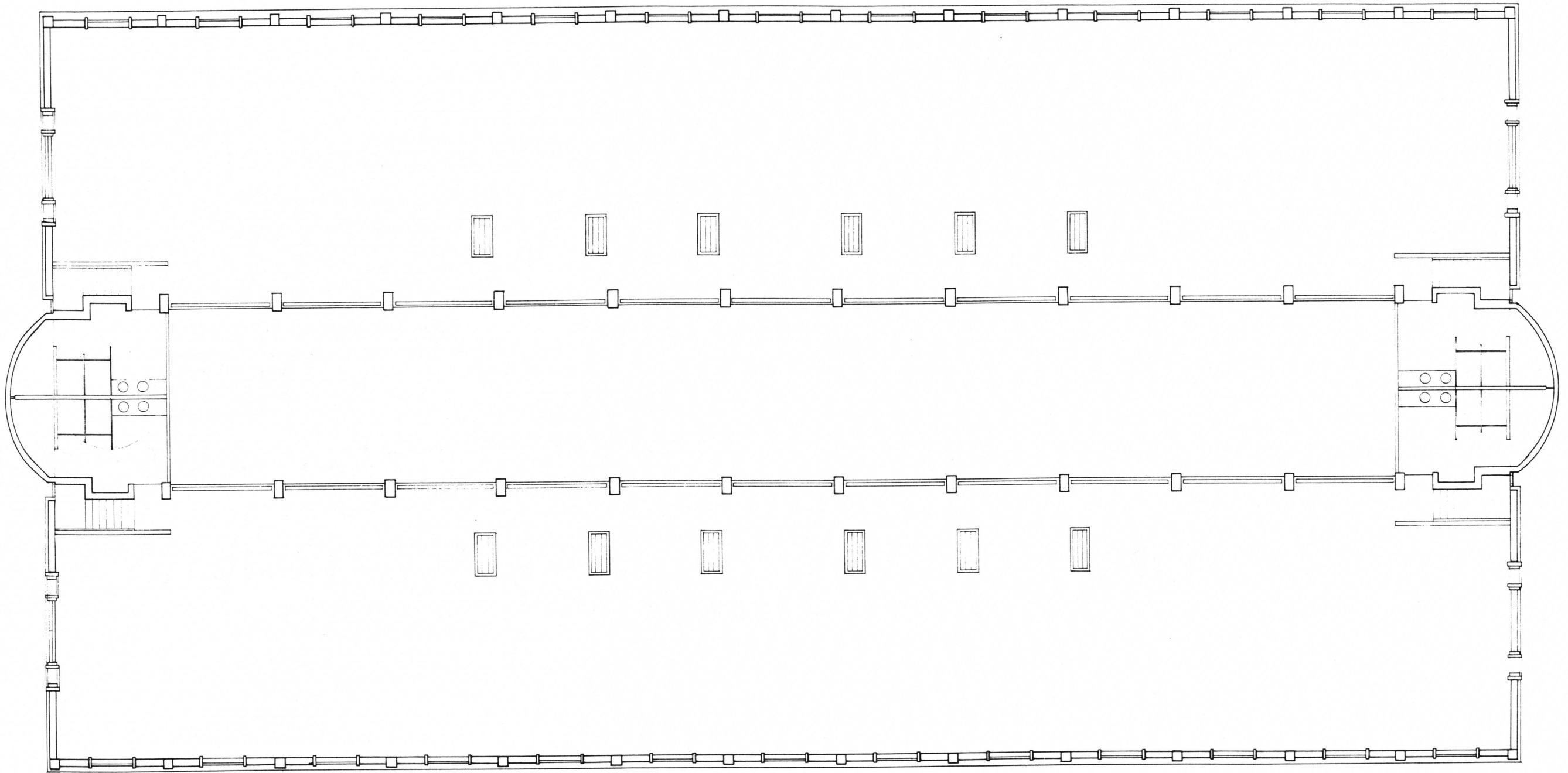

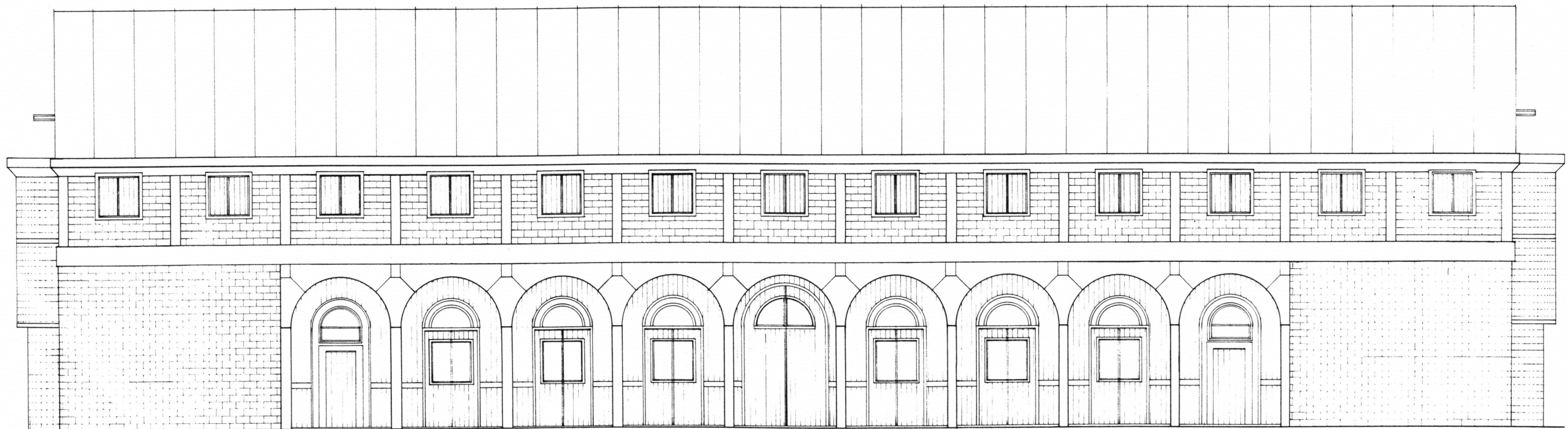

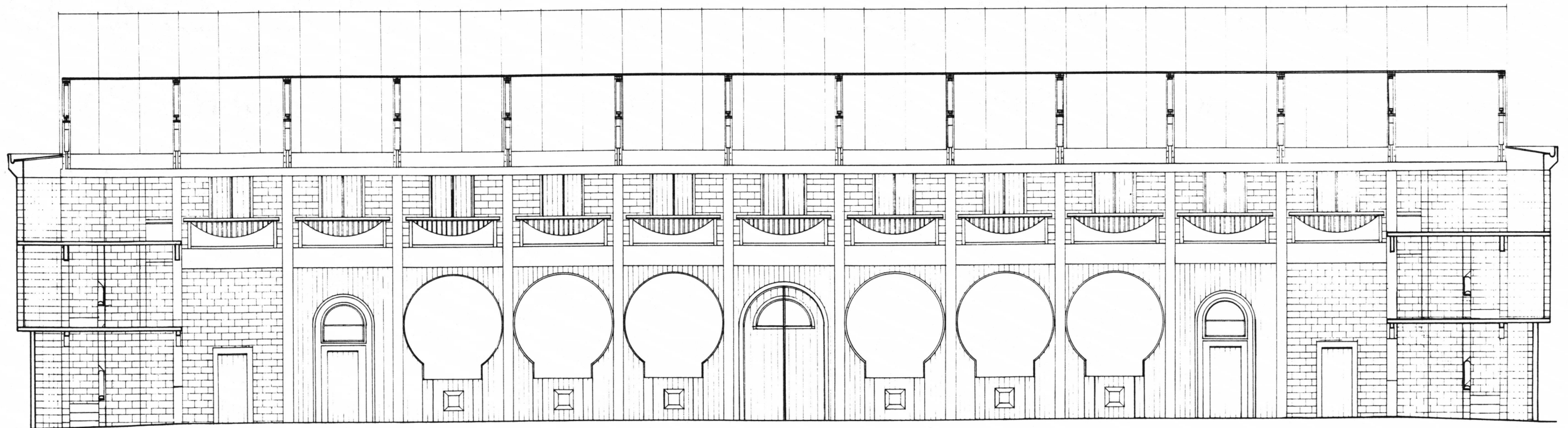

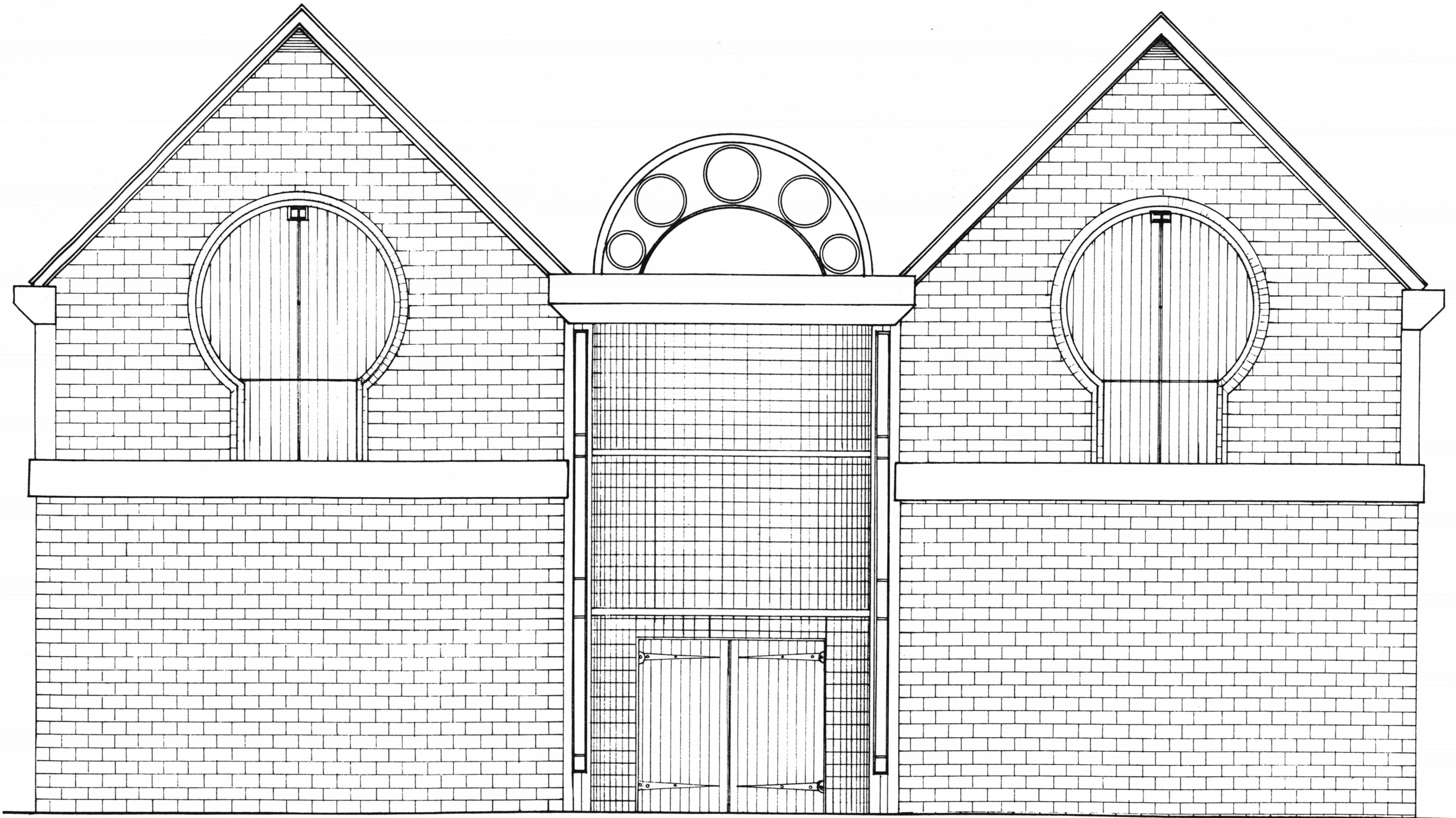



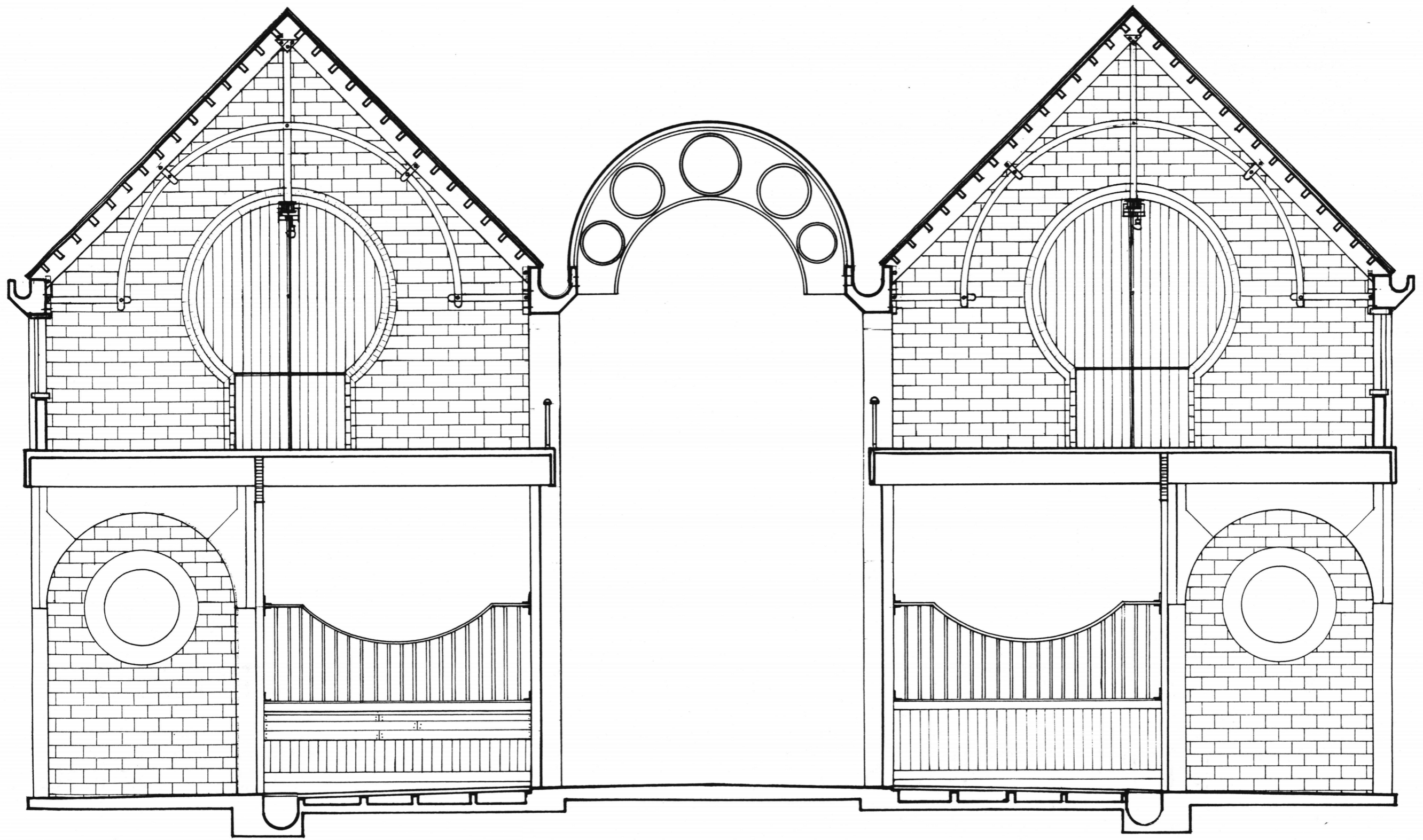

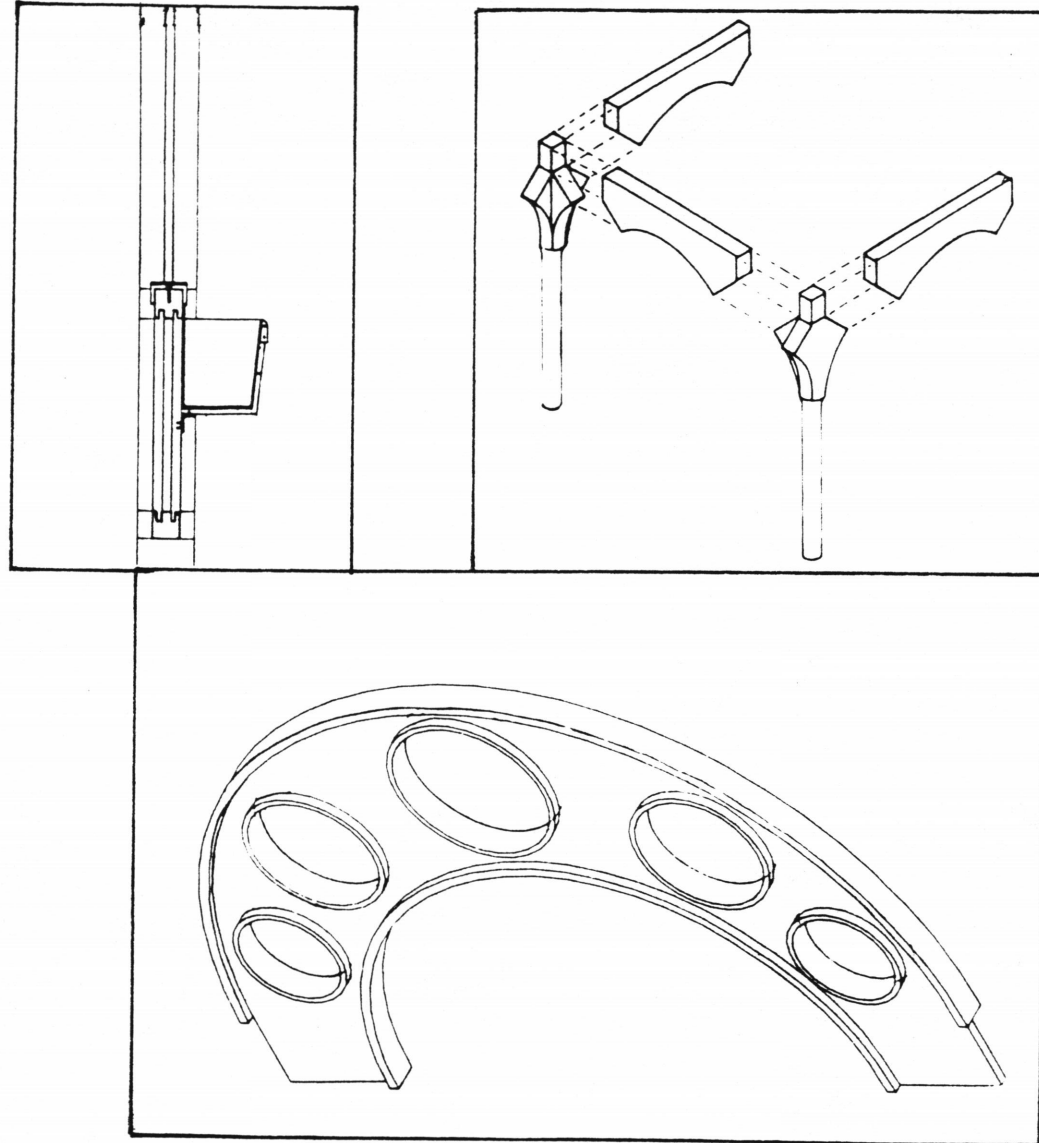
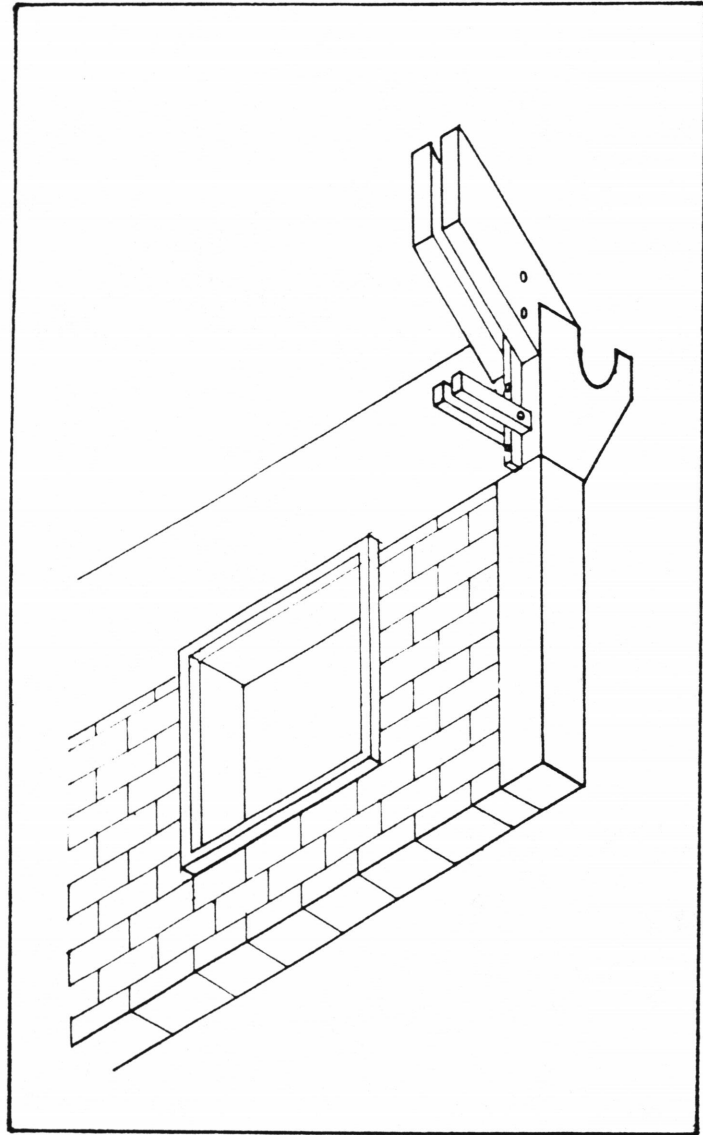

*'O investigator do not
flatter yourself that
you know the things
nature performs for
herself, but rejoice in
knowing the purpose of
those things designed
by your own mind.'*

Leonardo da Vinci

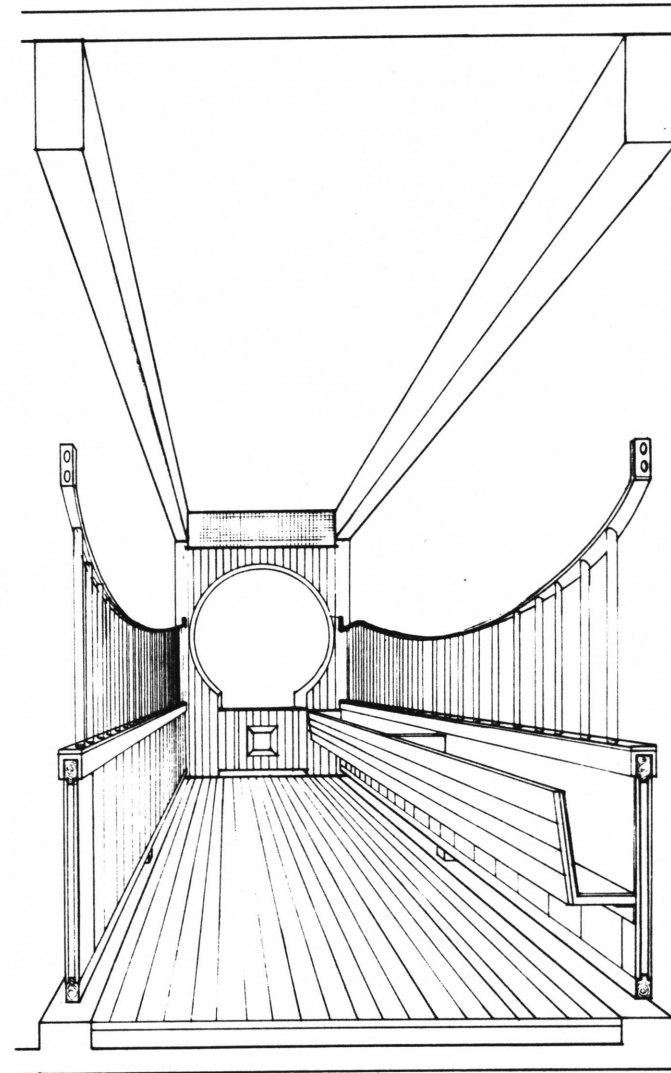

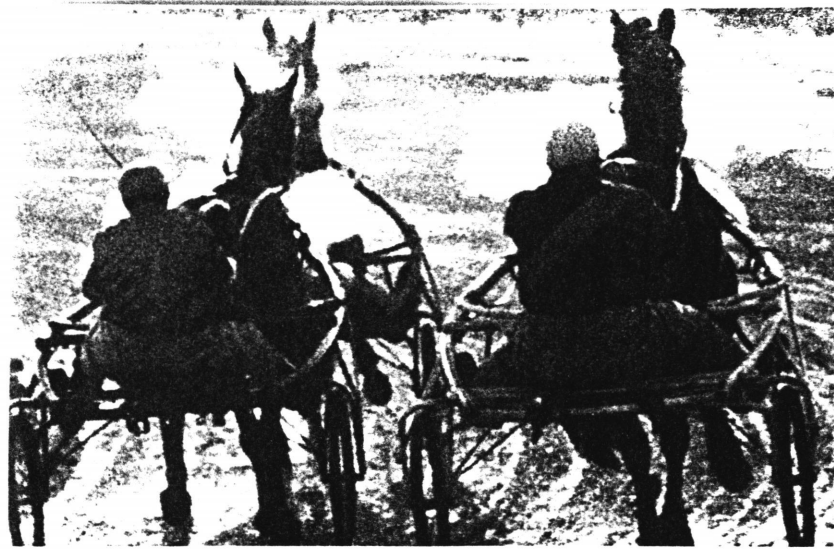

REFERENCES

- Gianou, Luigi. Horses and Horsemanship Through the Ages. New York: Crown Publishers Inc.,1967.
- Hearne, Vicki. Nervous Horses. "Emergence"
Texas: University of Texas Press, 1980.
- Kemp, Martin. Leonardo da Vinci The Marvellous Works of Nature and Man. Massachusetts:
Harvard University Press, 1981.
- Pedretti, Carlo. I Cavalli di Leonardo. Johnson
Reprint Corporation, 1984.

**The vita has been removed from
the scanned document**