

12  
B22  
V10  
1991  
M103  
C.2  
Folio

# LINES

by

William R. Merryfield

Thesis submitted to the Graduate Faculty of the  
Virginia Polytechnic Institute and State University  
in partial fulfillment of the requirements for the degree of

MASTER OF ARCHITECTURE

In

Architecture and Environmental Design

APPROVED:

August, 1989  
Blacksburg, Virginia

Hans Rott / Chairman

Jaan Holt

Olivo Ferrari

Ellen Braaten

Rengin Holt

# LINES

by

William Merryfield

(Abstract)

- Spirit
- Responsibility
- Making
- Judgement

ii

The thesis contains a series of ideas & conclusions:

The introductory statement suggests four criteria for the pursuit of producing good architecture. These criteria are not in the realm of problem solving. But rather address issues of the heart & mind. It is through a struggle with these measures that architecture becomes true and encompasses a realization larger than the problems at hand. It is only then that architecture exists in a continuum across time.

The projects in this book make a meager attempt to begin to understand a pedagogy for spirit, responsibility, making & judgement.

■ DEDICATION

- Thanks To:
- Ellen Braatén  
*Stability...*
- Olvio Ferrari  
*Wisdom...*
- Jaan Holt  
*Insite...*
- Rengin Holt  
*Mystery...*
- Hans Rott  
*Courage...*

- To My Parents.  
*Love. . . .*
- To My Teachers.  
*Erudition. . . .*
- To My Mentors.  
*Discernment. . . .*
- To My Friends.  
*Acceptance. . . .*
- To Architecture Itself.

■ CONTENTS

Abstract	ii
1 Statement....	
2 An Axis for Rain	
	<i>A line between two points....</i>
10 Sketches of a Tower	
	<i>A vertical line makes a tower....</i>
21 A House of Four Views	
	<i>Two intersecting lines of four directions....</i>
30 A House of Columns	
	<i>A space between two parallel lines....</i>
38 A Wall As Gate	
	<i>A line makes a wall....</i>
Vita	42
Bibliography	43



## ■ STATEMENT

It is the responsibility of the Architectural schools to impart a vast array of knowledge and understanding to the young Architect. Architecture cannot only be a discipline of facts. In our pursuit to produce good Architecture there are some basic issues to be questioned and addressed. I believe these issues are indispensable to learning about, as well as making, good Architecture.

### ■ Spirit

Architecture has existence. It is, as it always has been and as it always will be. We, as designers and Architectural educators, must instill within ourselves the struggle of that which is not sure. The underlying spirit of things that compels us to do what we do and bring meaning to our undertakings. Kahn uses the term, the unmeasurable, in describing this phenomenon. This spirit provides the connectivity that orders time, and links the past and present to the future. It is this underlying principle that begins to order the existence of Architecture. The making of good Architecture starts with this spirit. It is the purpose of the Architect to translate and bring into being the intangible existence of Architecture. And by using reasoned action to give it its presence. This reality, in turn, manifests the culture and dignity of humanity.

### ■ Responsibility

Architecture is an art, we are striving to become artists. As artists, creating Architecture, we have a responsibility to Architecture itself. All great buildings speak the essence of their time. The Architects of these buildings become our mentors. It is toward these structures that we direct our questions. It is only through a discourse with Architecture itself, both past and present, that we can find the potential of the future. It is ourselves, the educators, practitioners and students who must accept the responsibility of the precedent set before us.

### ■ Making

Making becomes the journey of bringing a realization into being. It is only through making that an Architect finds his way to create his art. Louis I. Kahn speaks of form preceding design. For Kahn, form refers to the essence of a thing and design, as the bringing into being of a thing. The essence of a building refers back to the existence of Architecture itself. But the bringing into being of Architecture belongs only to the maker. *Making becomes personal.* It is the Architect who has control over the action of design. It is only through this process that the Architect can affect the significance of Architecture. Knowledge, thinking, and one's ability and skill become the beginning of the journey. I believe that we as designers and educators, must realize the joys of the process of making. And that the capacity to make, the bringing into being under the guidance of reason, has nothing to do with utility. It is only through the conscious desire of ourselves, to improve our knowledge, thinking abilities and skills, that we will be able to create, through making, good buildings.

### ■ Judgement

Intelligent judgement is the most primary of all things in the yielding of good Architecture. Sound judgement is made possible only by awareness of spirit, responsibility and making. Judgement merges the act of making, the discovery of ones ideals; with utility, the analysis and synthesis of facts. The act of making and the formulation of utility adduce the realization of a building. Judgement then, becomes the verification of our ideals and understandings to the larger context of the world. It confirms our creations to the existence of Architecture, and brings resonance to our personal act of making. The development of sound judgement is an essential task of the Architectural schools. It is the right of the young Architect to choose, through sound judgement, that which will effect the possibilities of the future.

- Spirit
- Responsibility
- Making
- Judgement

## An Axis for Rain

Project  
A pavillion  
and an amphitheatre  
in a park.  
Both are fountains.  
Activated  
by the rain.  
Collecting water.  
A park for the  
lovers of rain.  
An axis to  
walk along.  
Umbrellas and rain.

Amphitheater  
A setting to  
experience the rain.  
Based on history.  
An event of cascading  
and collecting water.  
Performed only by rain...  
A place.

Pavillion  
A gazebo to  
watch the rain.  
Based on tradition.  
A roof system to  
collect water.  
Activated only by  
the rain.  
A marker.

A line between two points

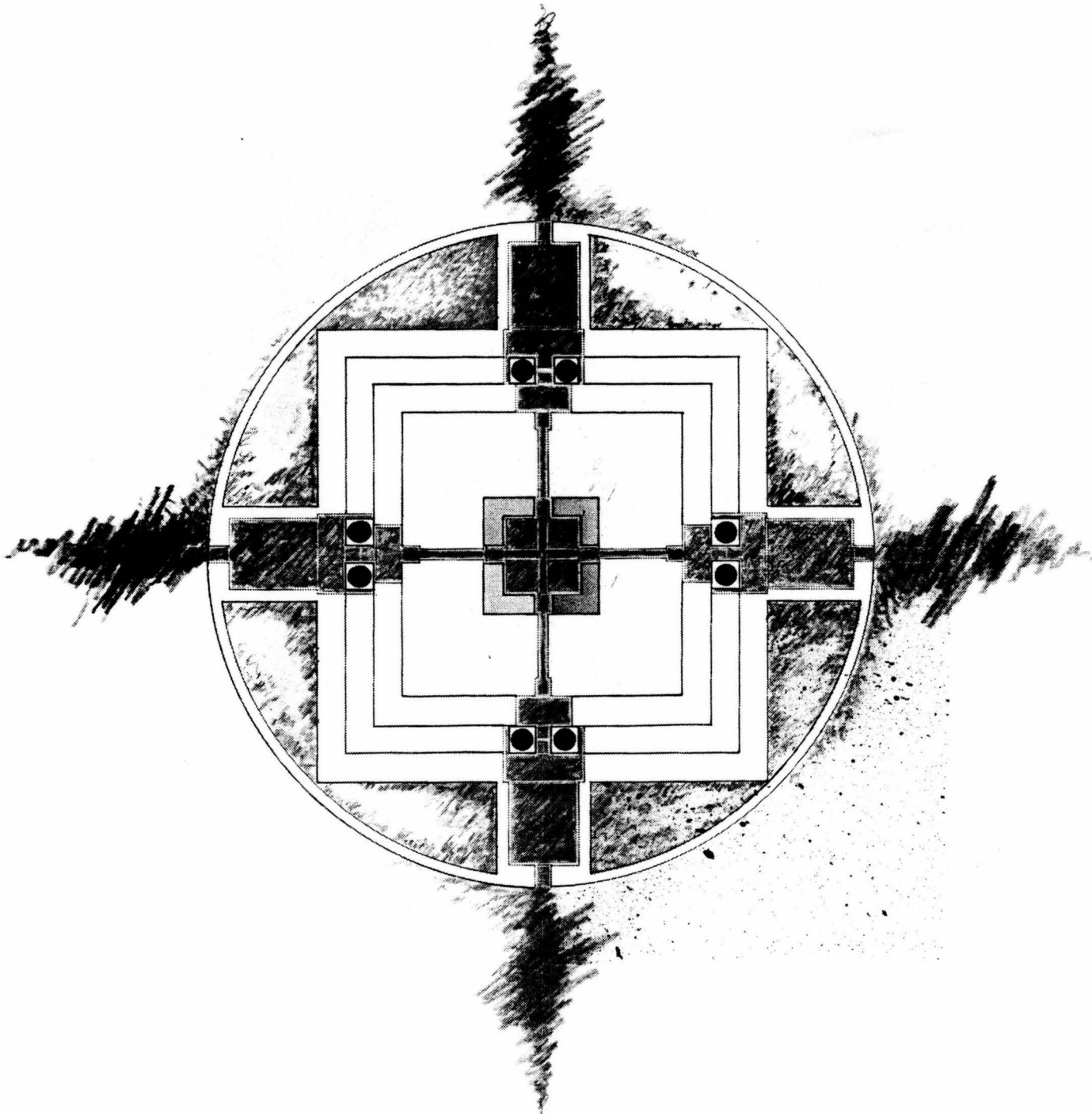

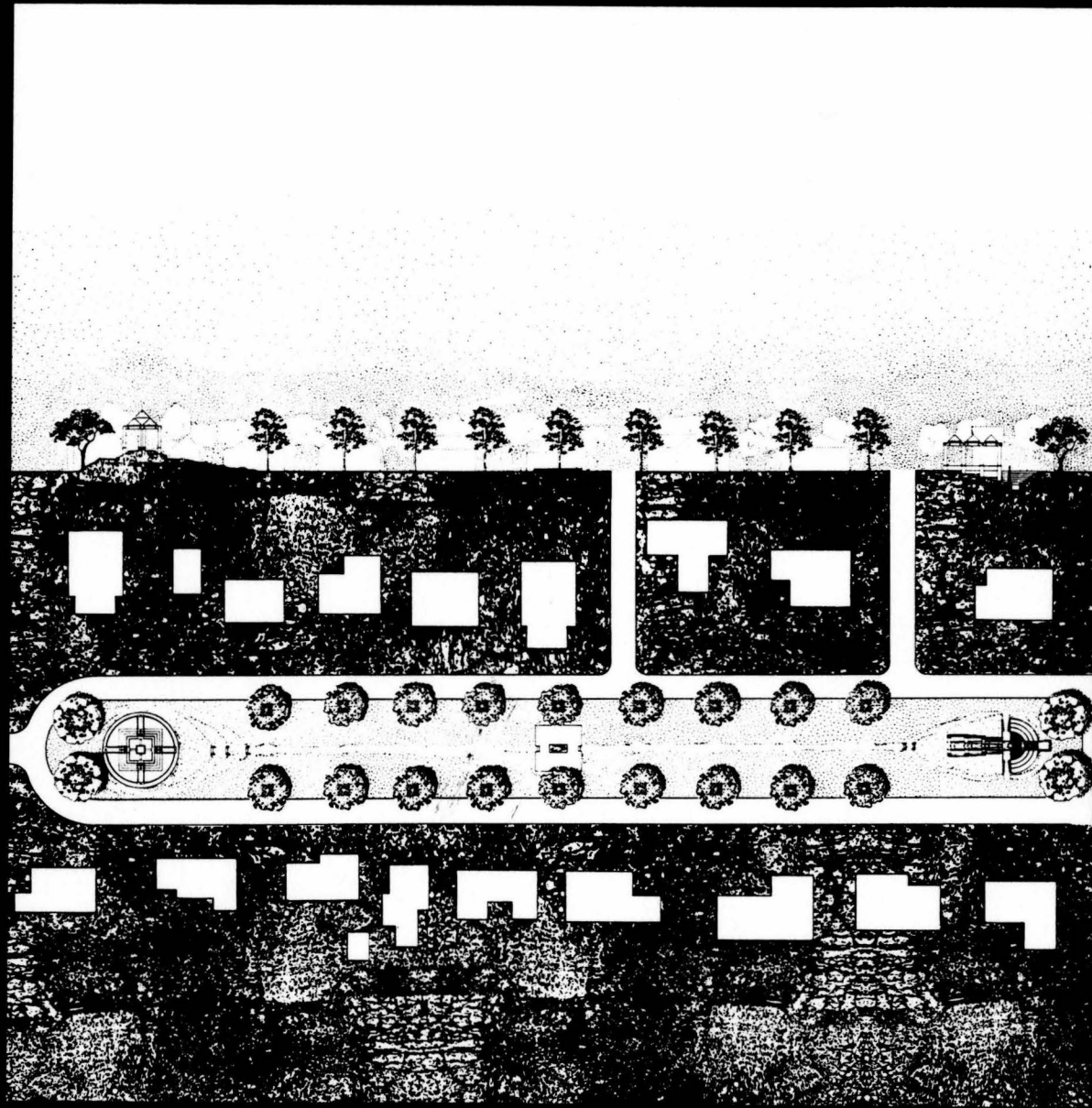

Site  
An entrance to  
a neighborhood.  
It rains in Louisiana,  
it pours.  
The site is a  
mall between two streets.  
A physical  
and visual axis.

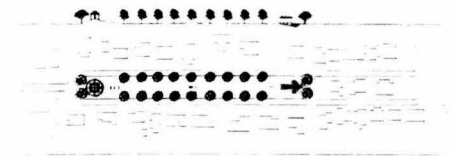

Pavillon  
A gazebo to  
watch the rain.  
Based on tradition.  
A roof system to  
collect water.  
Activated only by  
the rain.  
A marker.

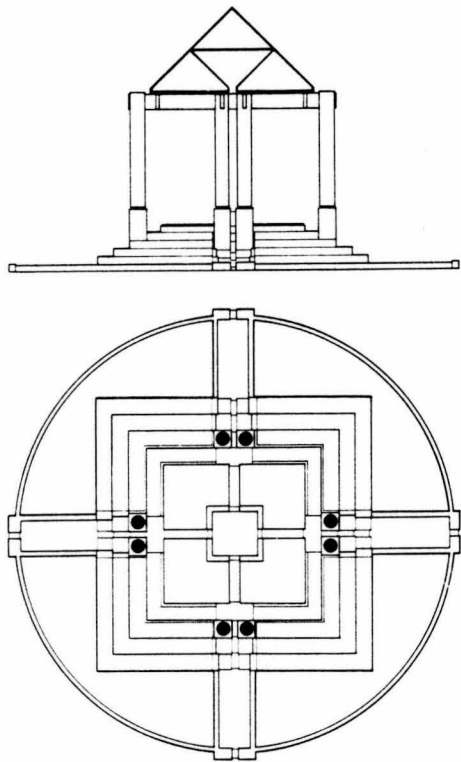
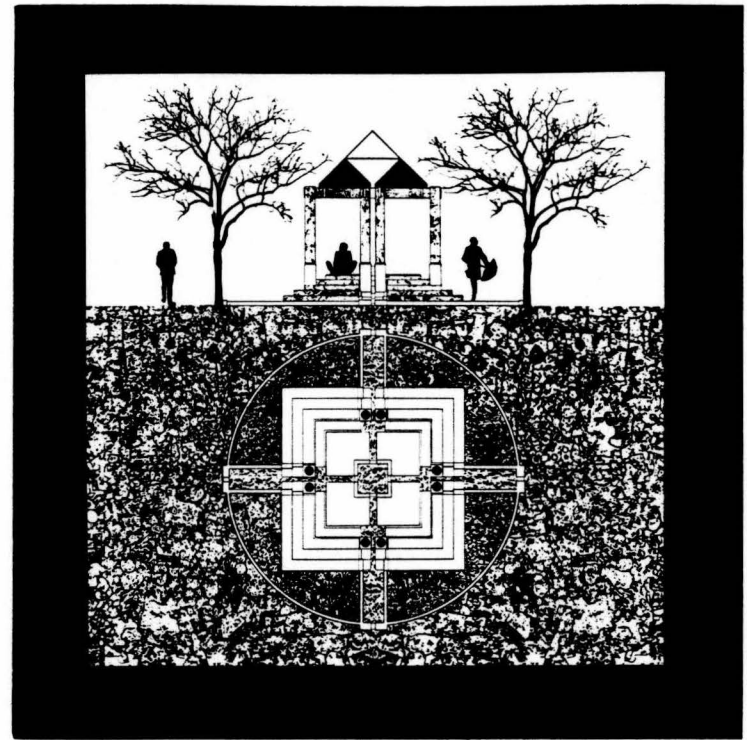

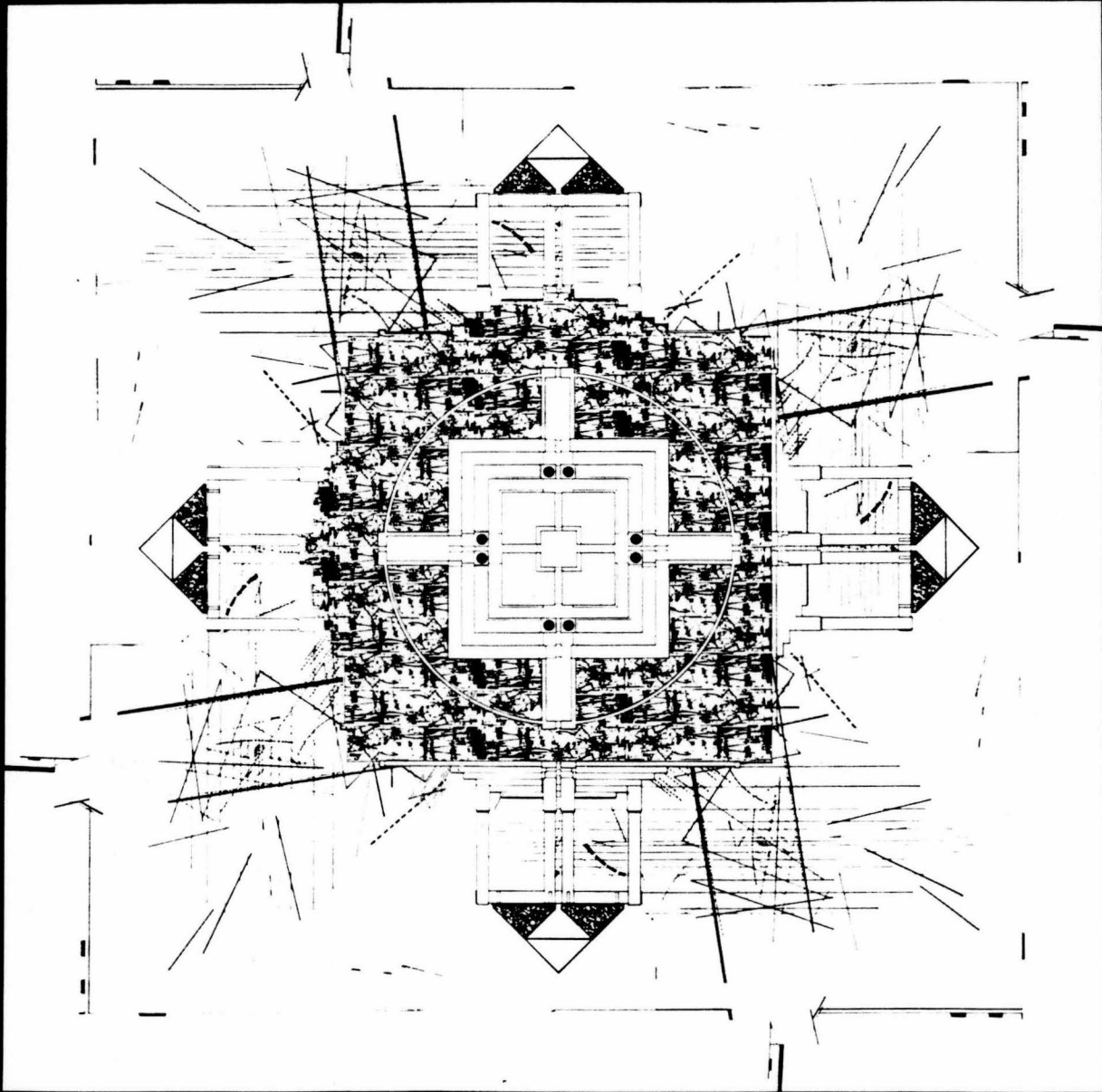

Rain falls on  
four pyramidal roofs,  
collecting in a central pool  
Water moves in grooves,  
incised in the floor,  
cascading as it moves  
between the columns  
and down the stairs.  
Finally stopping  
in four shallow  
reflecting pools  
and spilling onto  
the earth.

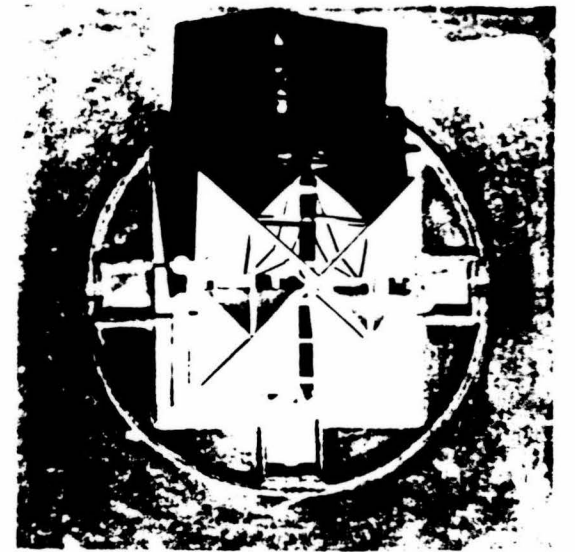



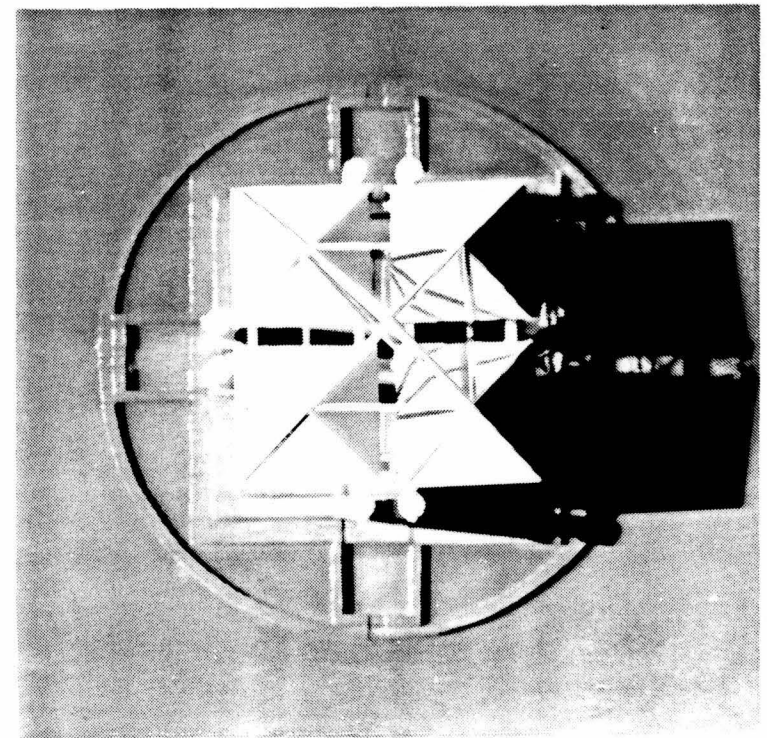
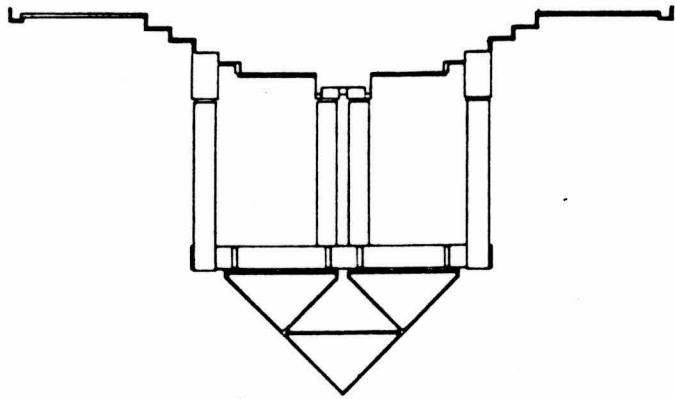
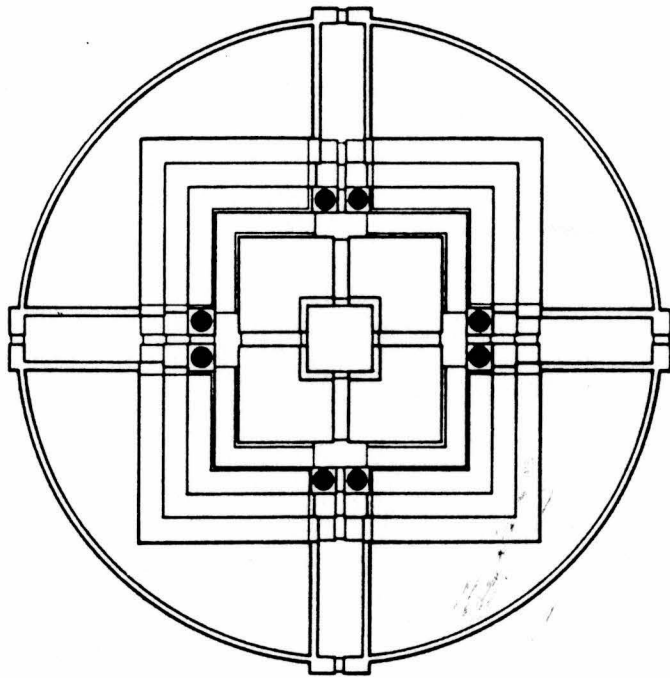
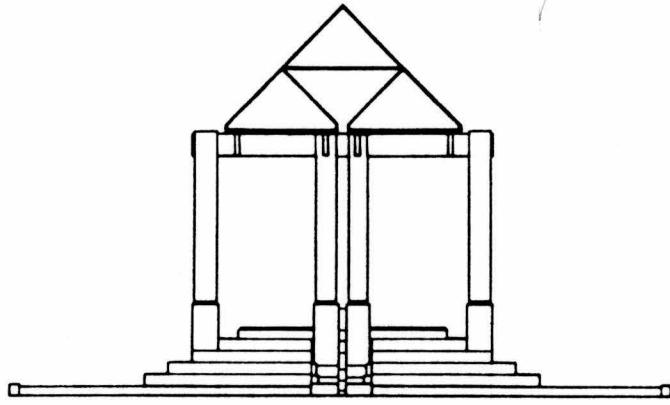

Amphitheater  
A setting to  
experience the rain.  
Based on history.  
An event of cascading  
and collecting water.  
Performed only by rain...  
A place.

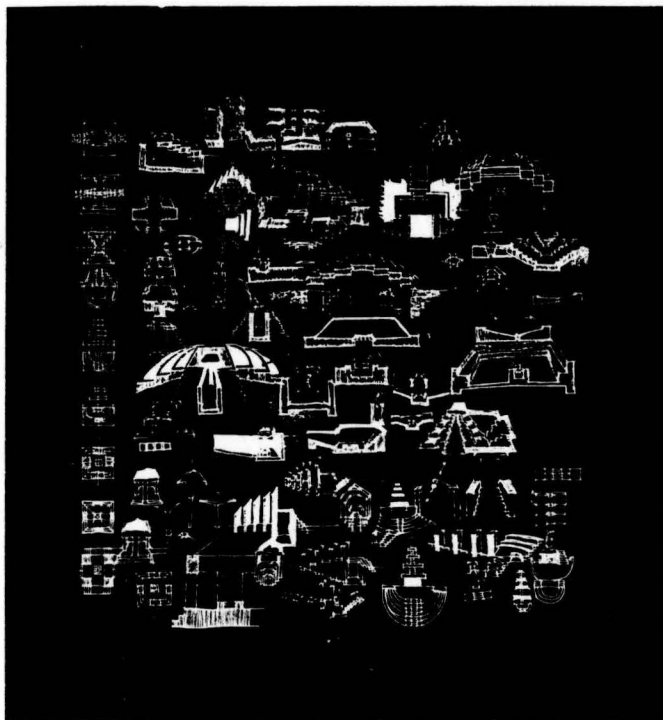
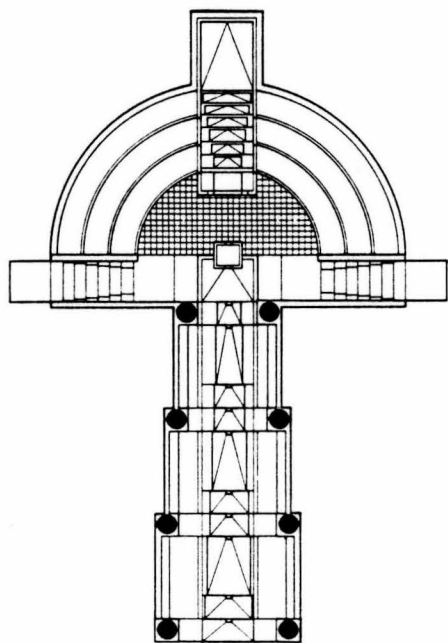
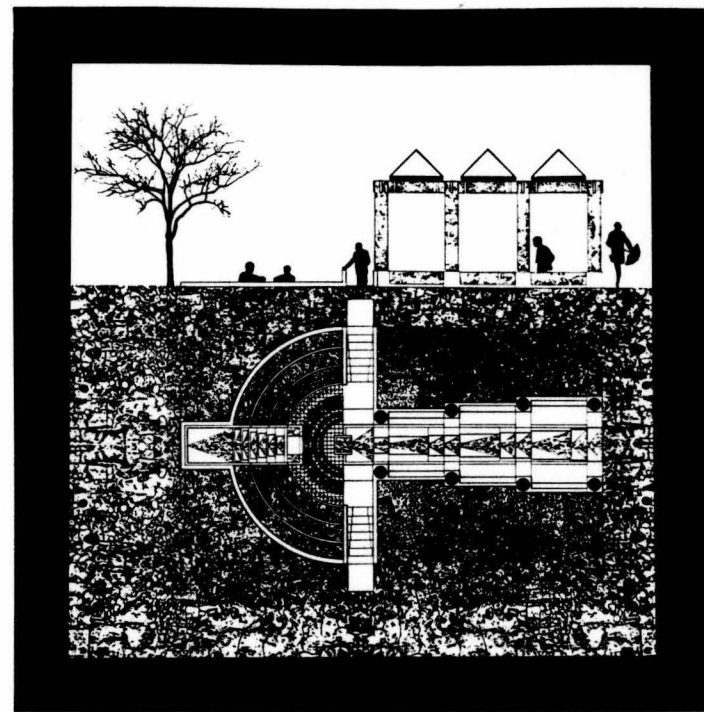

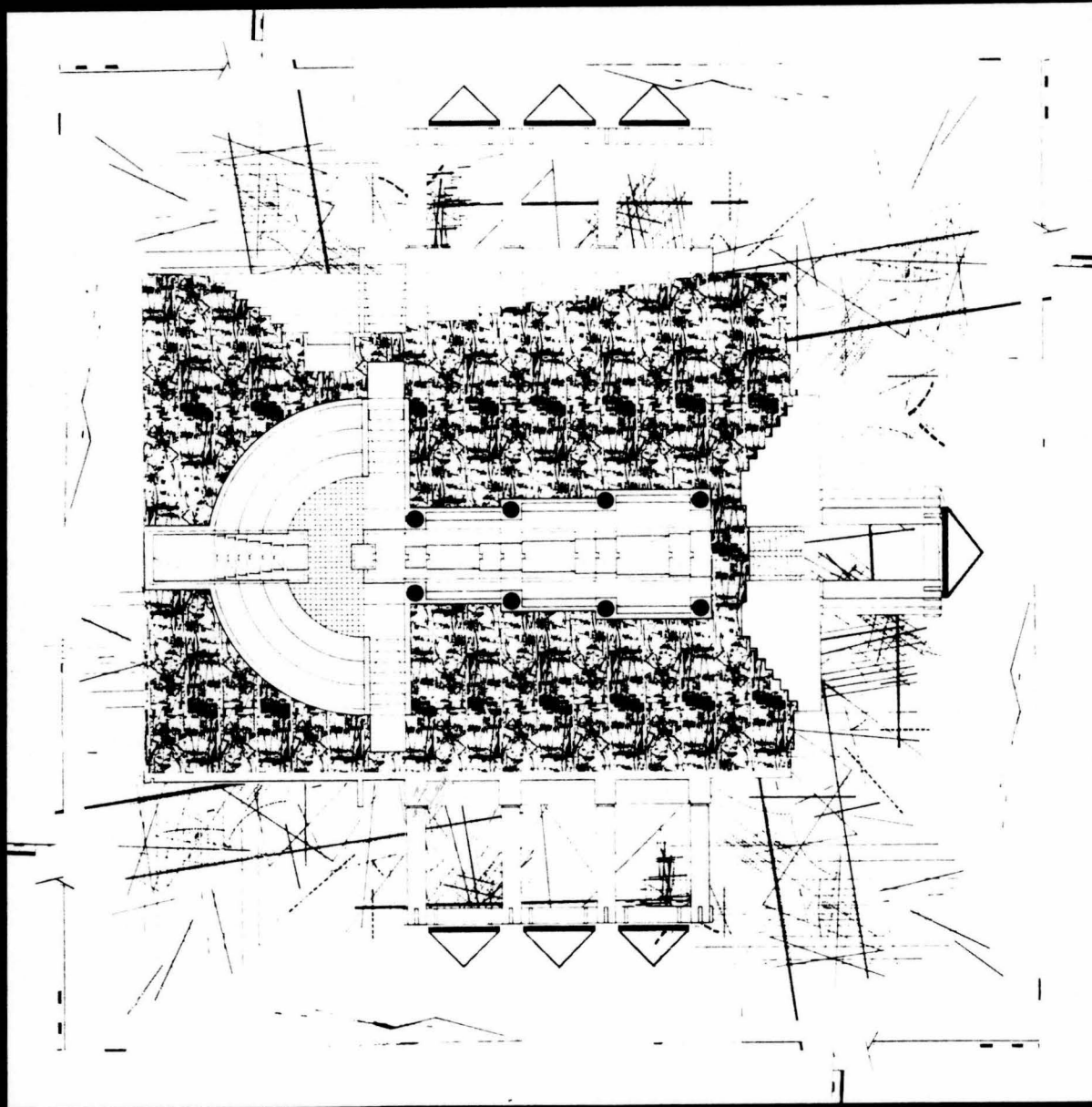

Rain is collected  
among the stairs  
at both ends  
of the amphitheater.  
The water cascades  
down toward the stage.  
It collects and falls,  
finally spilling into  
a cistern below  
the stage floor.

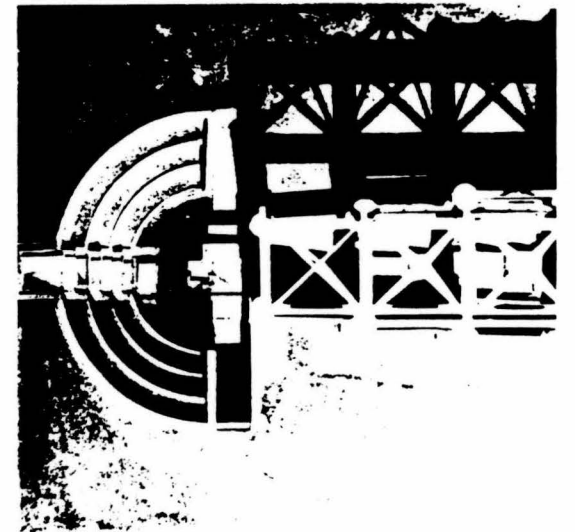



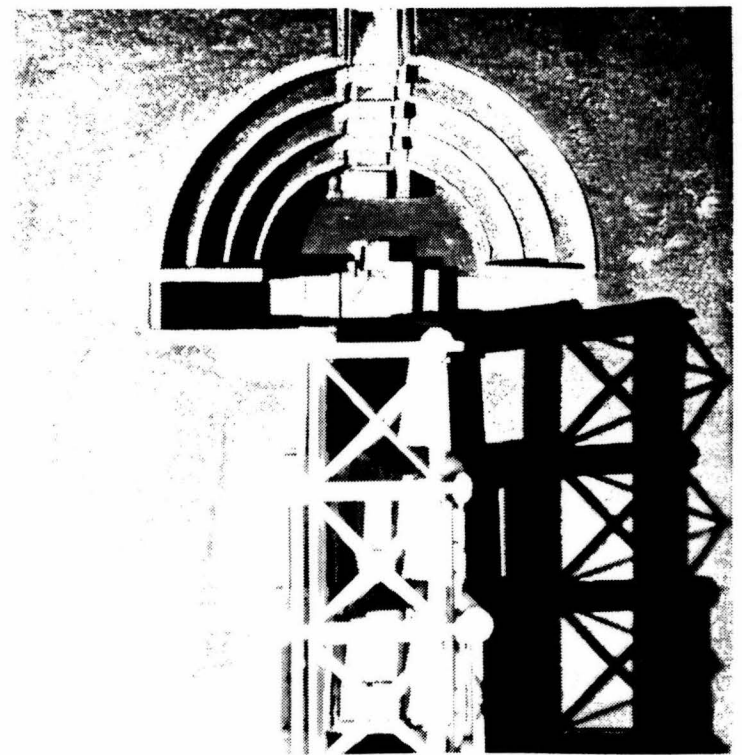
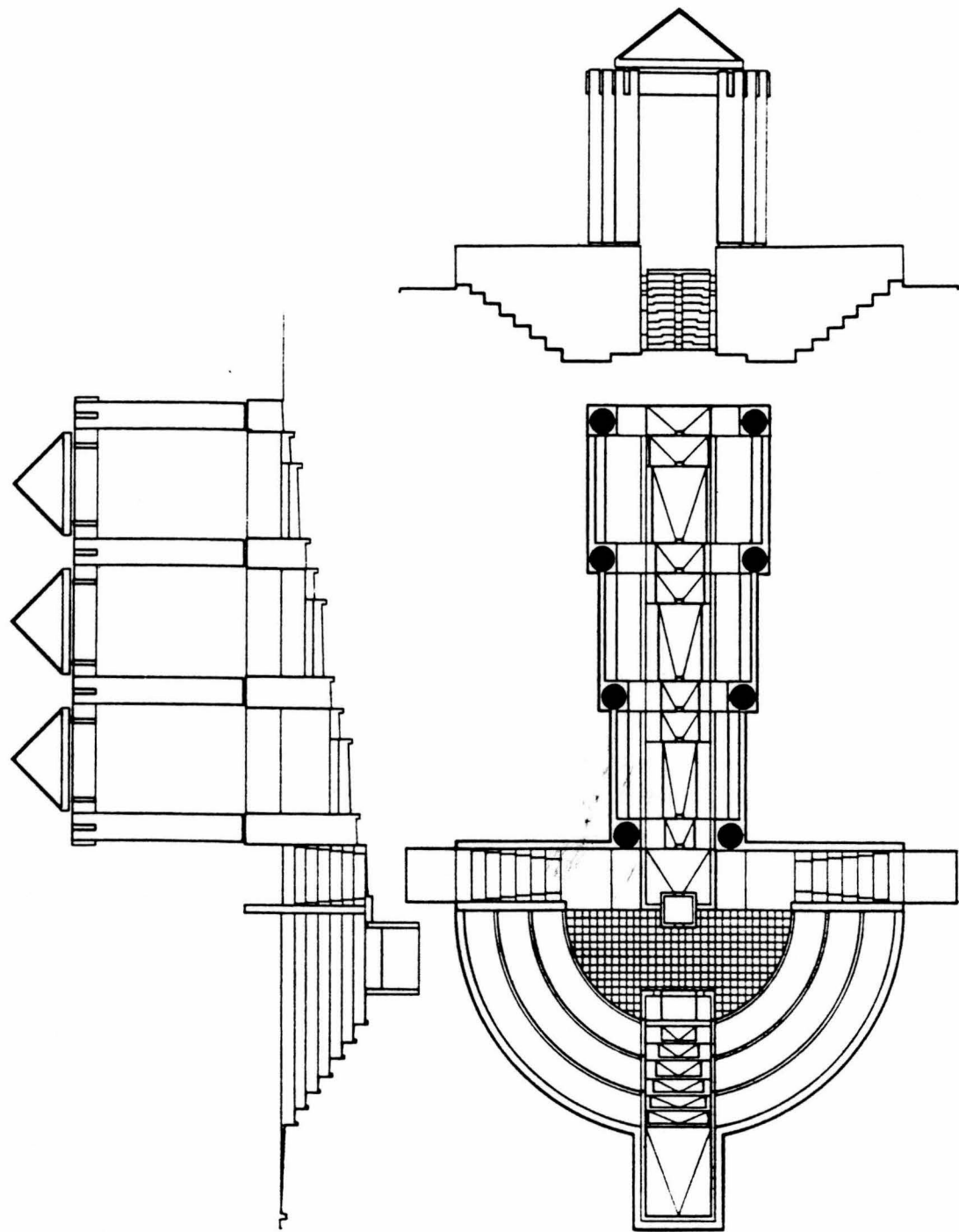

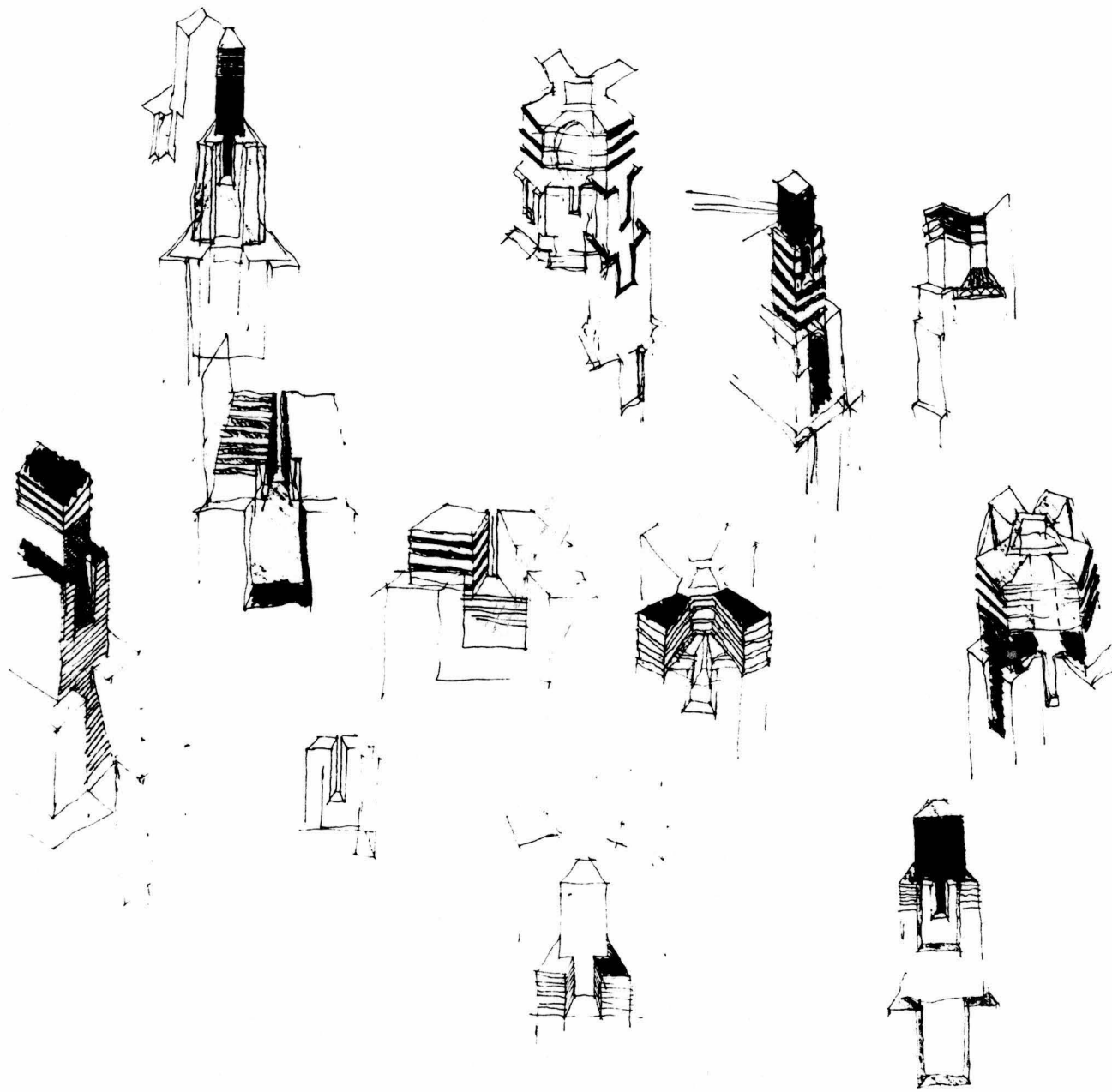

## Sketches of a Tower

An image to a city  
A beacon  
A split to catch light  
Transparency

A beacon for memory  
A greeting to morning incoming  
A salute to evening exit  
A point of reference

A society of grand rooms

Rooms at the capitol  
Views to the sky

Rooms at the base  
Refuge from the street

Others along a vertical journey  
Views to the city

A vertical line makes a tower

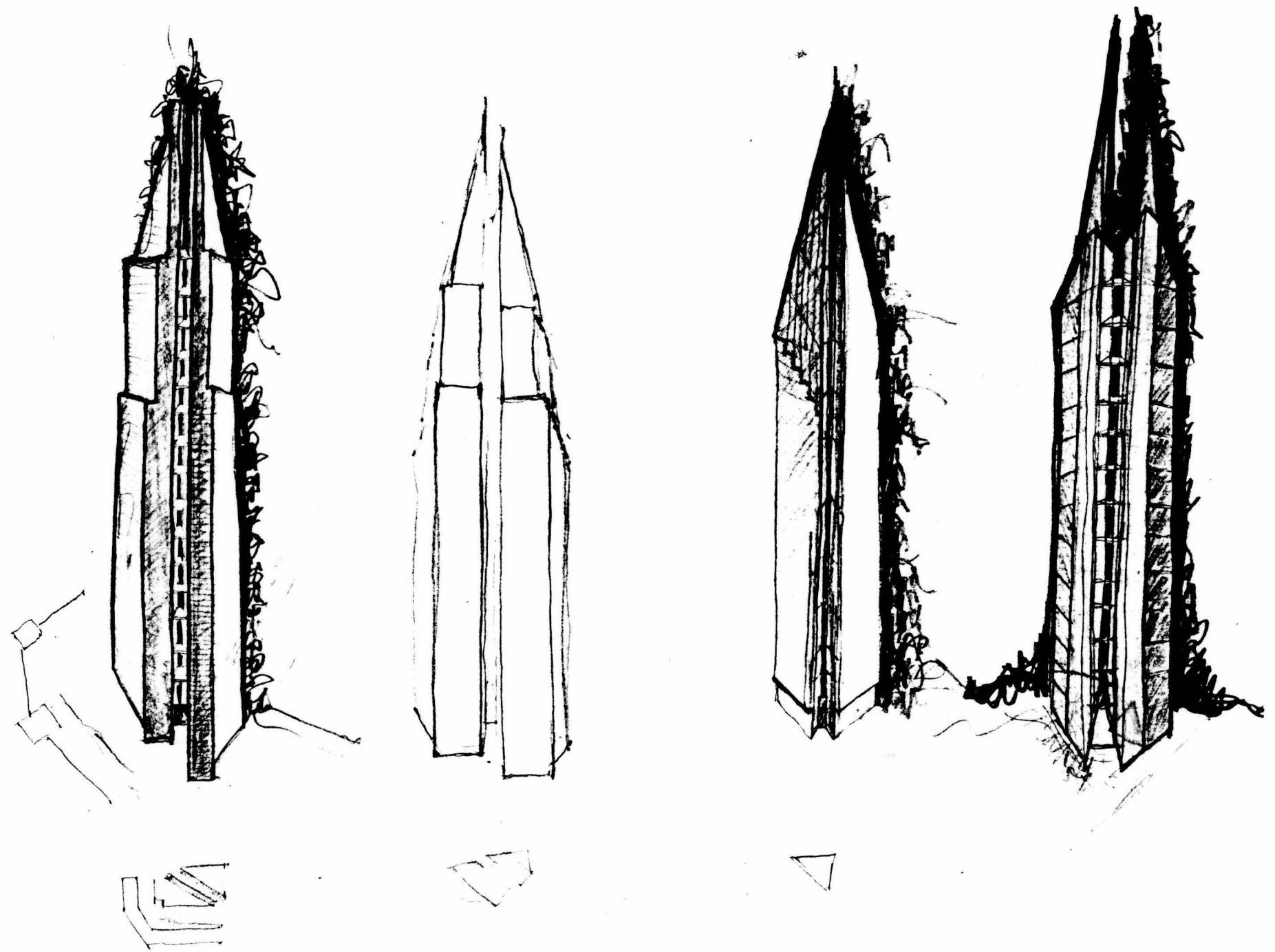

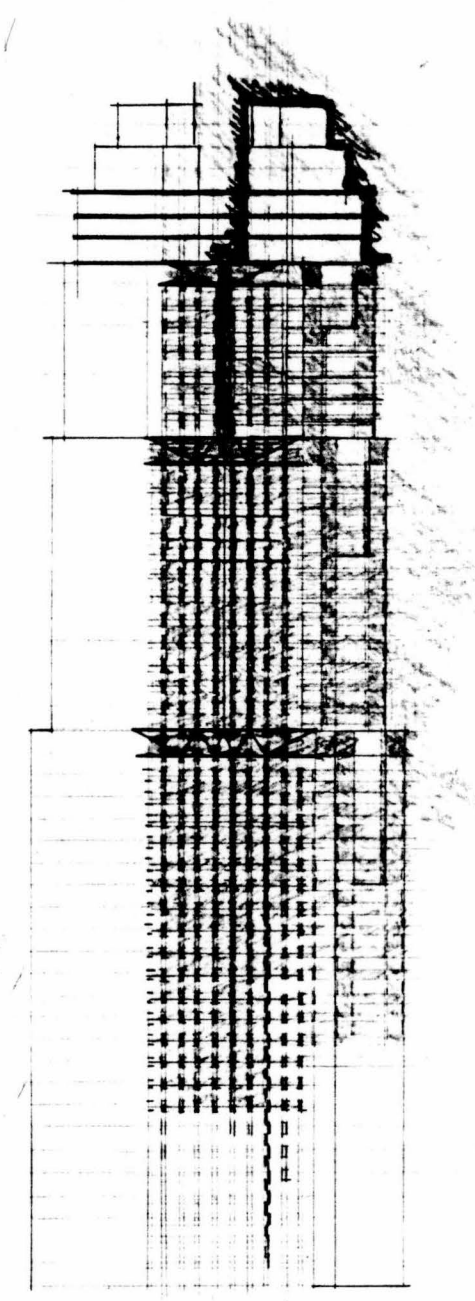
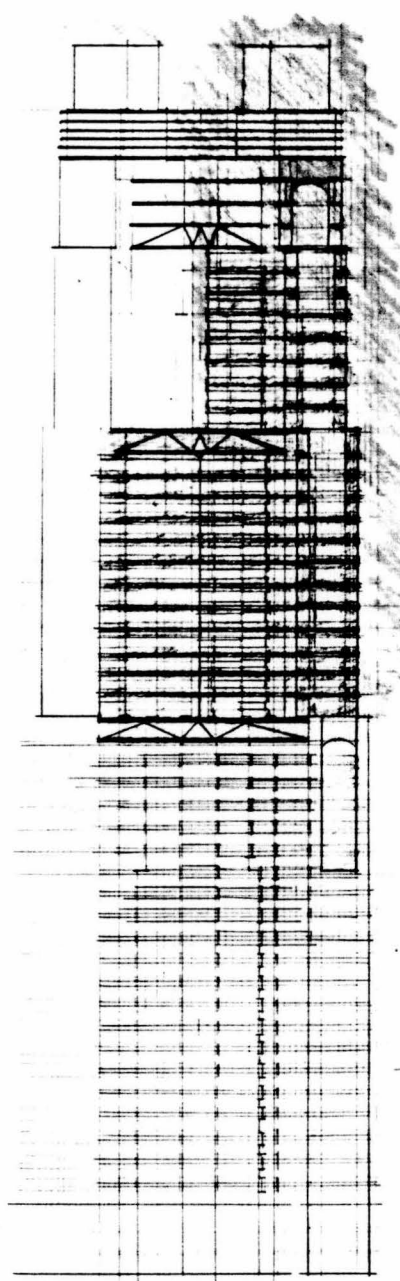

An image to a city  
A beacon  
A split to catch light  
Transparency

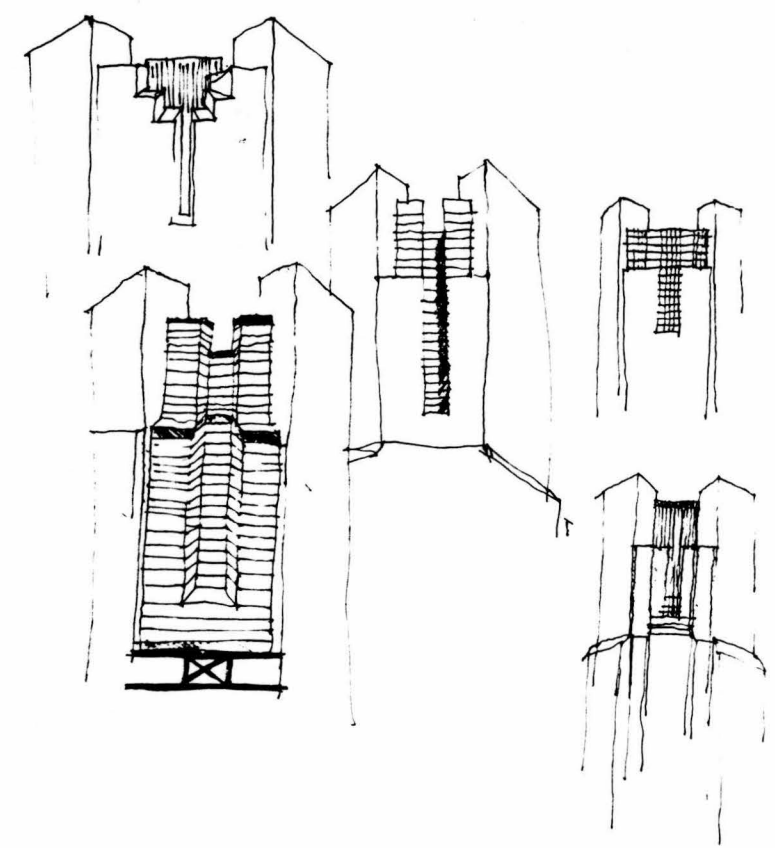

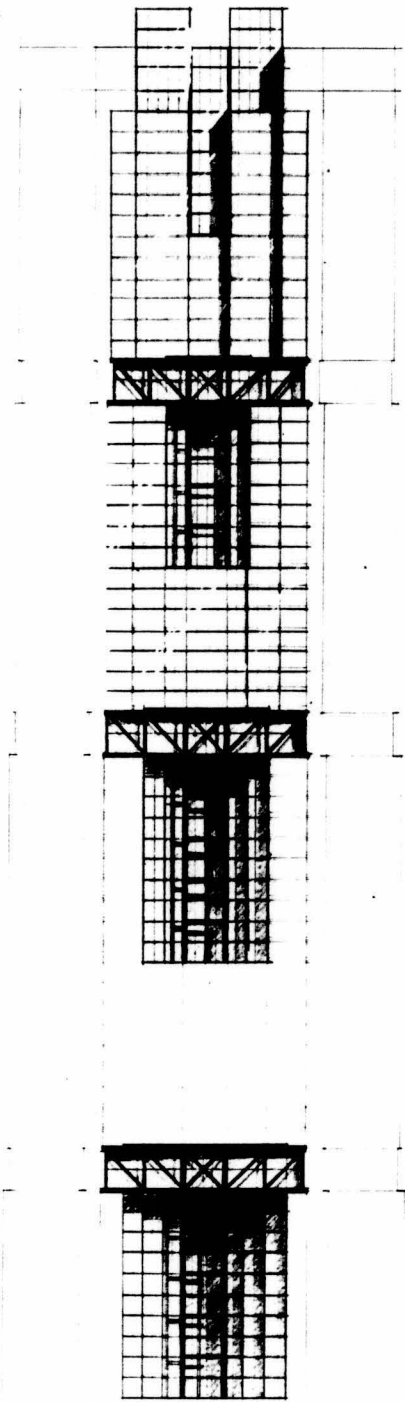

A society of grand rooms

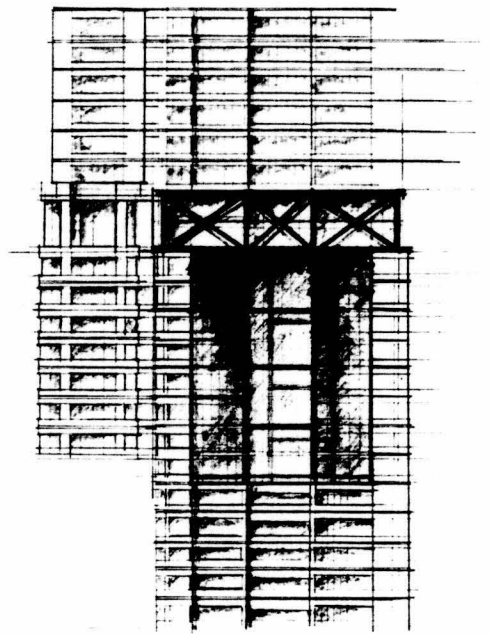

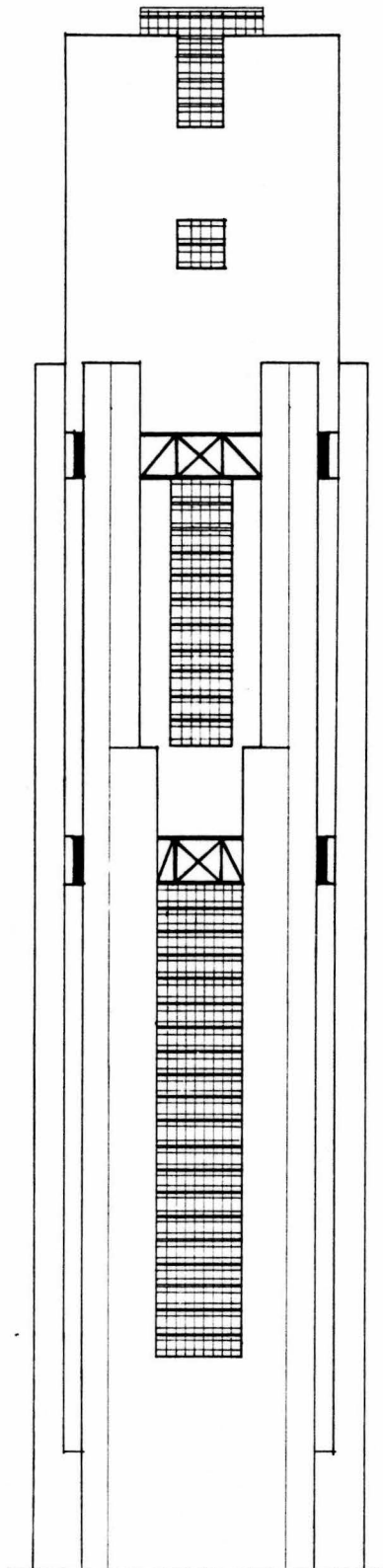
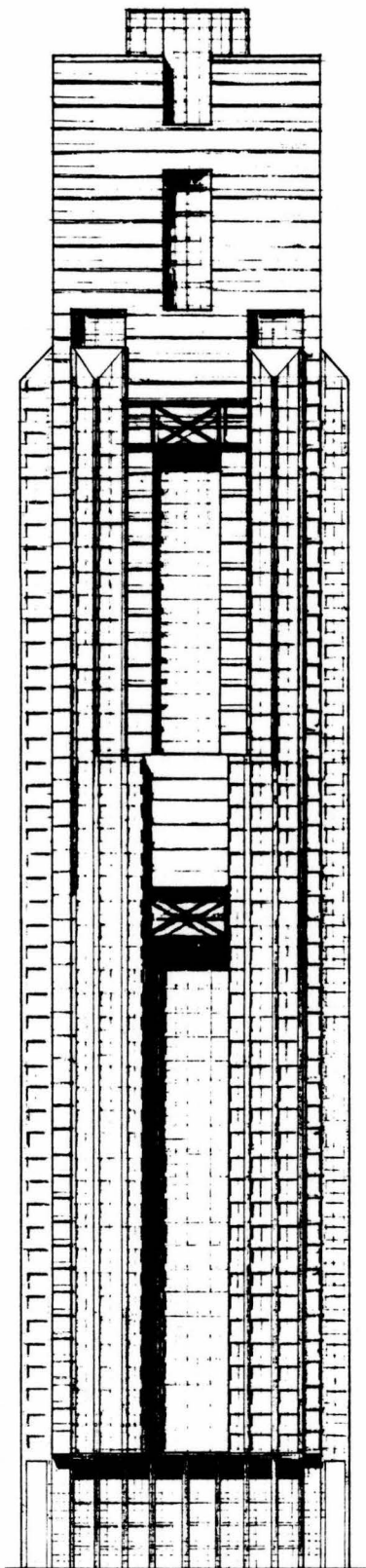

Rooms at the capitol  
Views to the sky

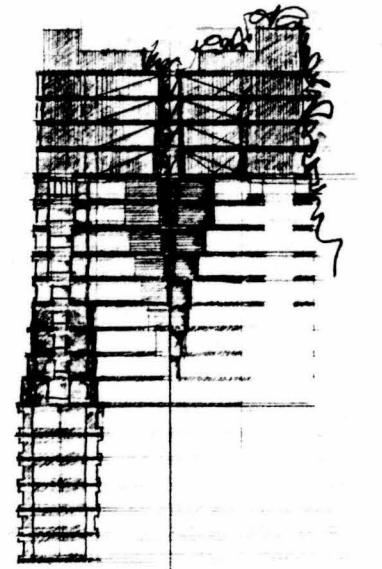

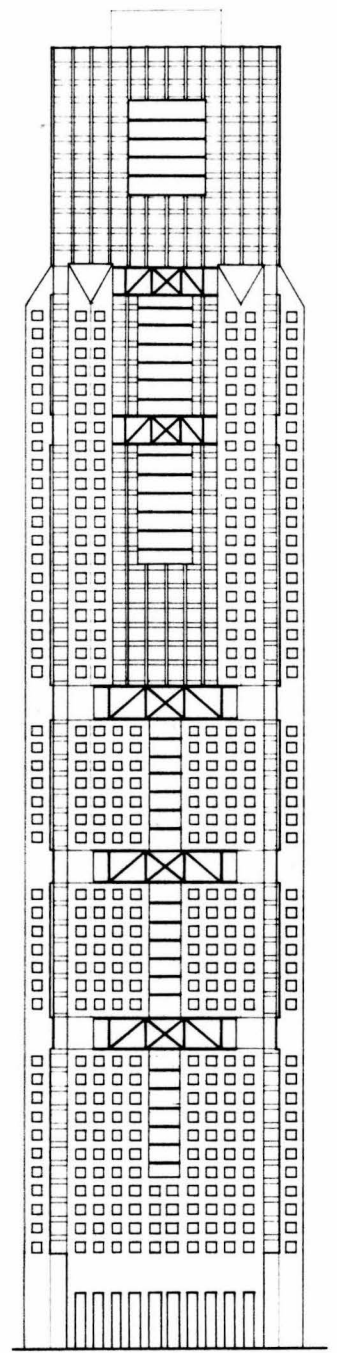
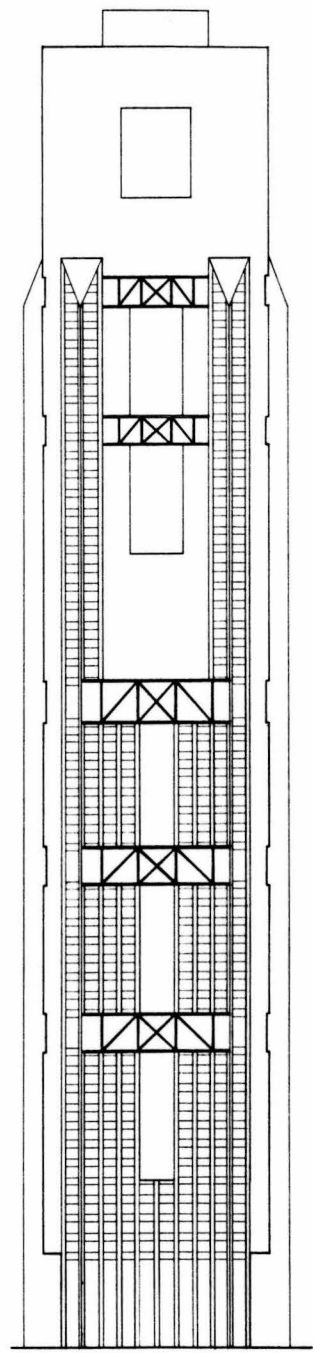
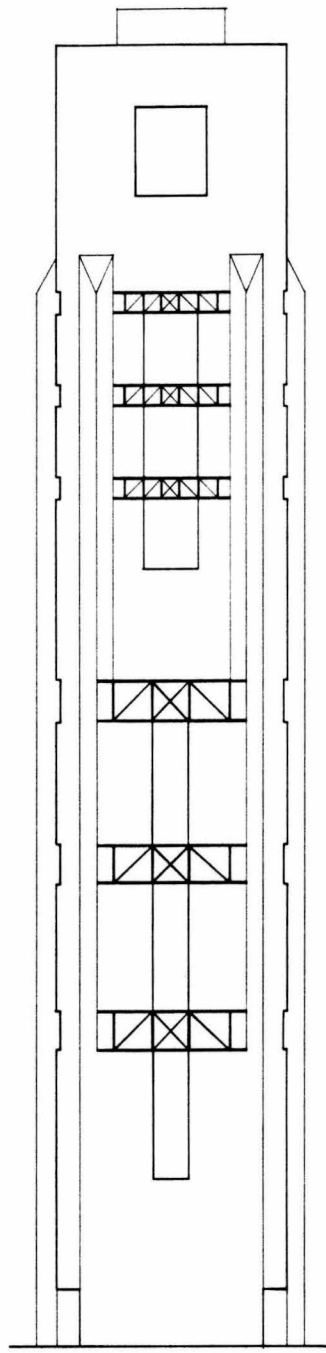
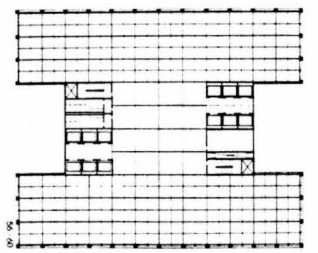
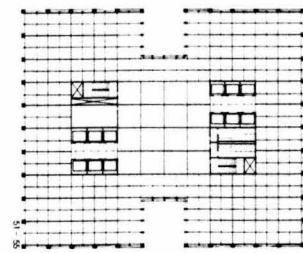
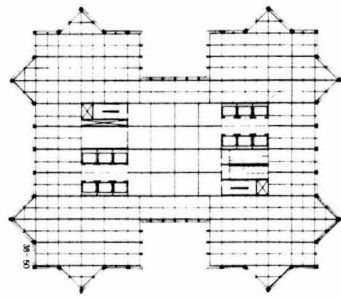
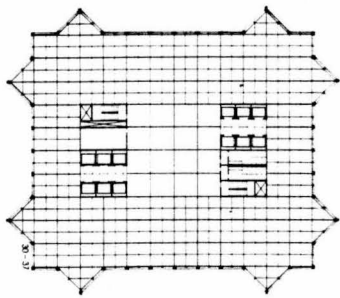
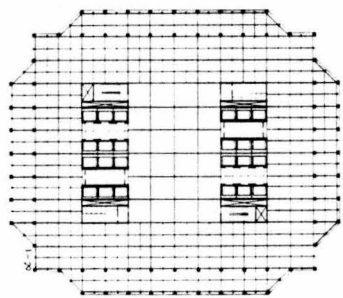



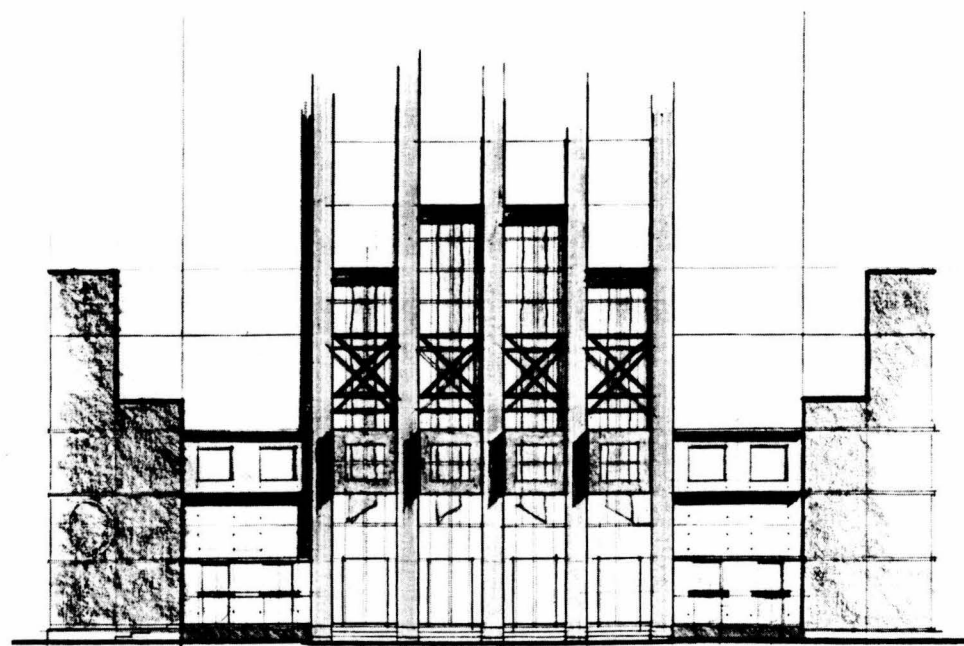
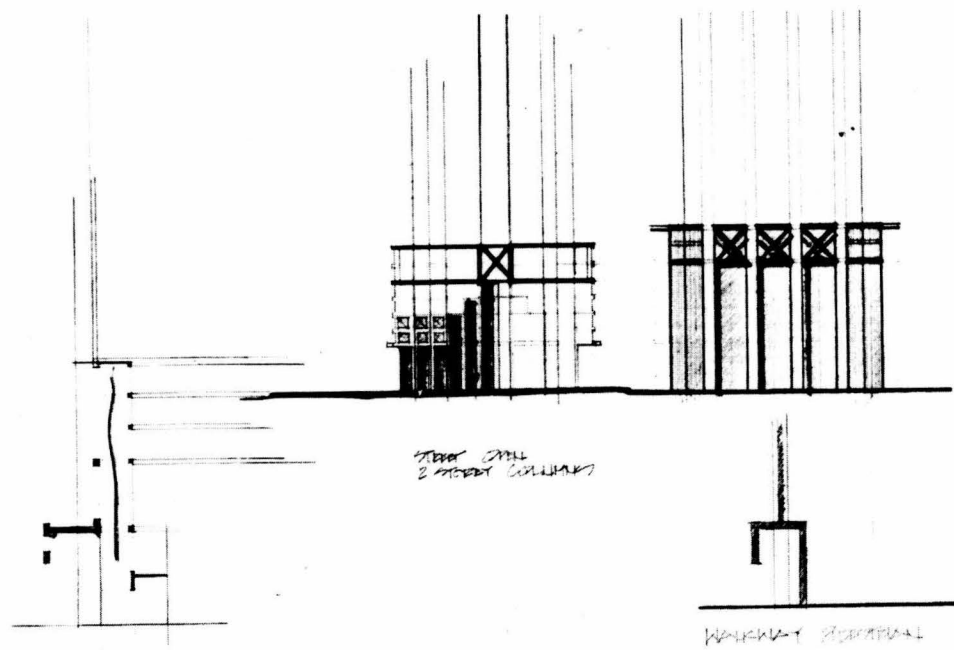
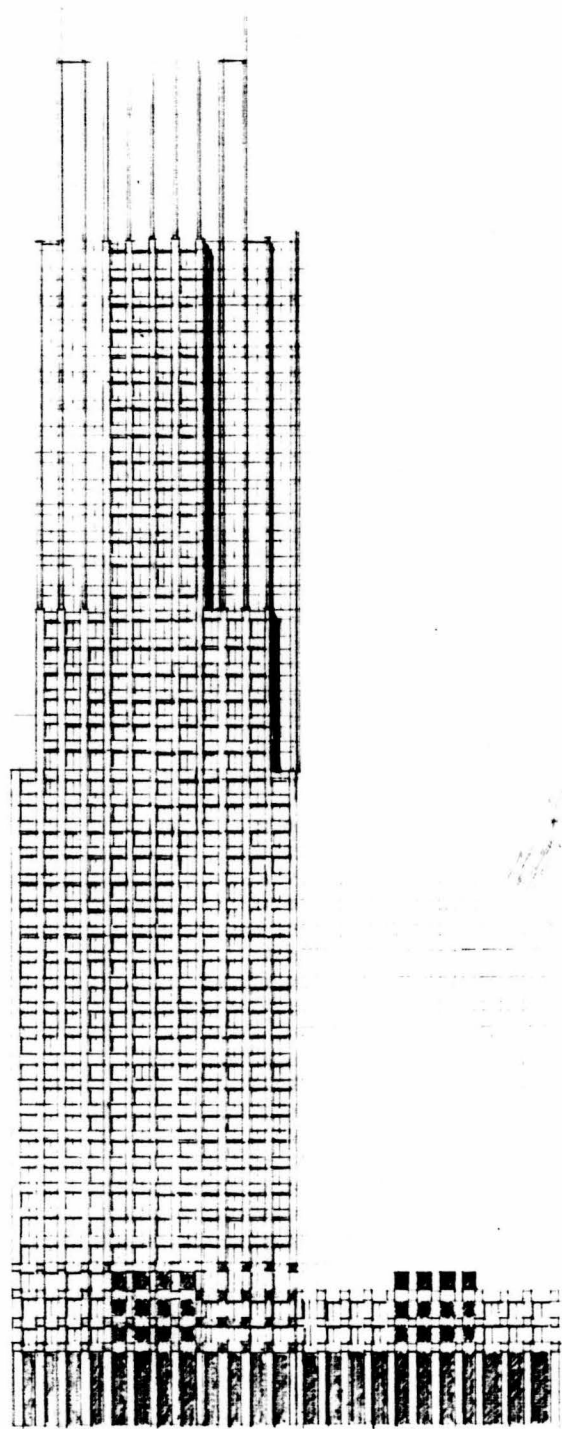



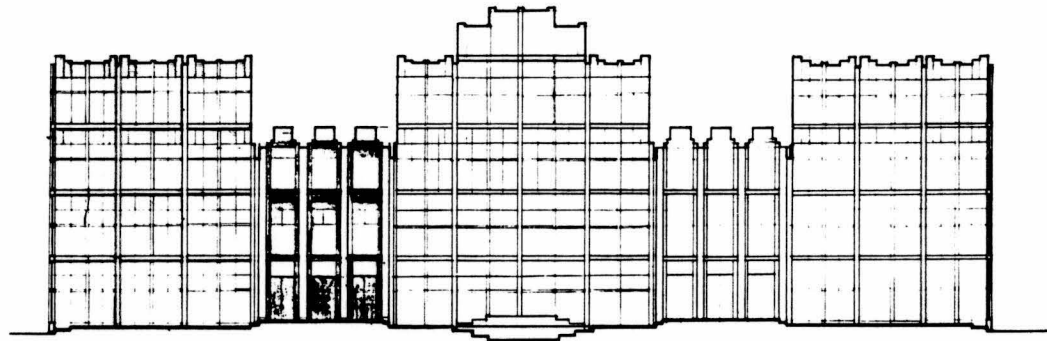

Rooms at the base  
Refuge from the street

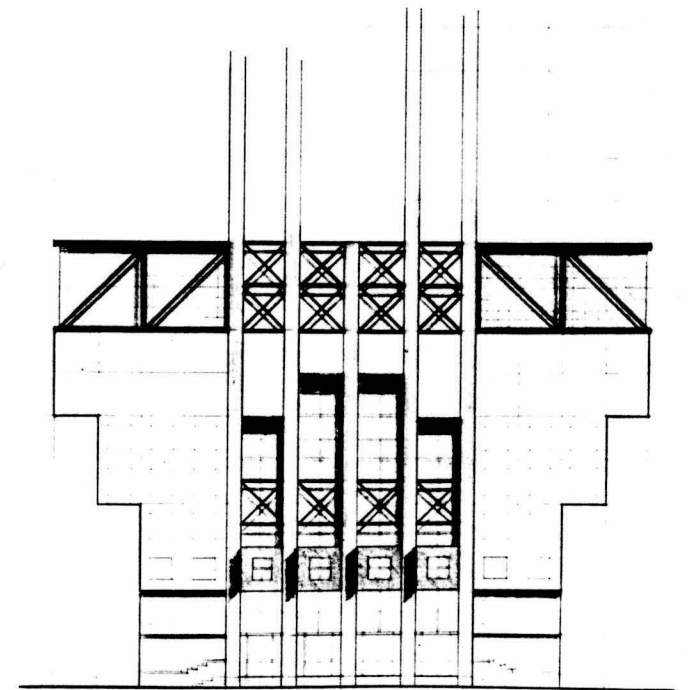
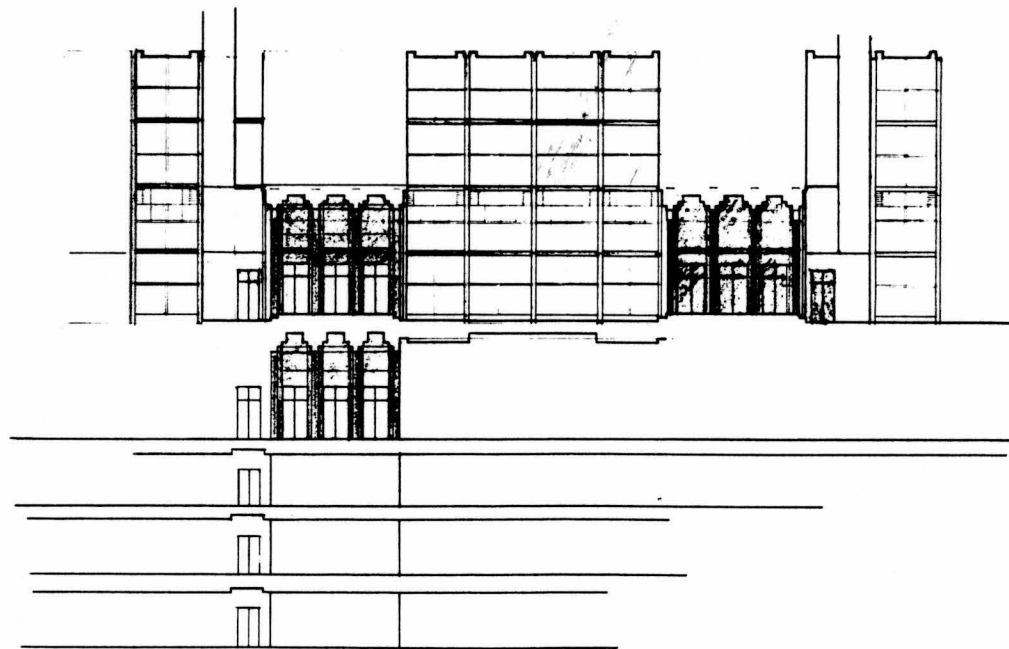

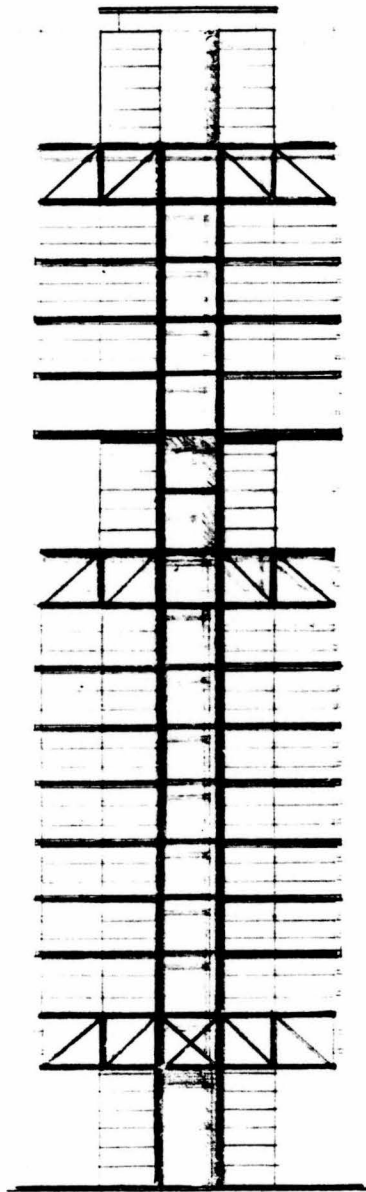

Others along a vertical journey  
Views to the city

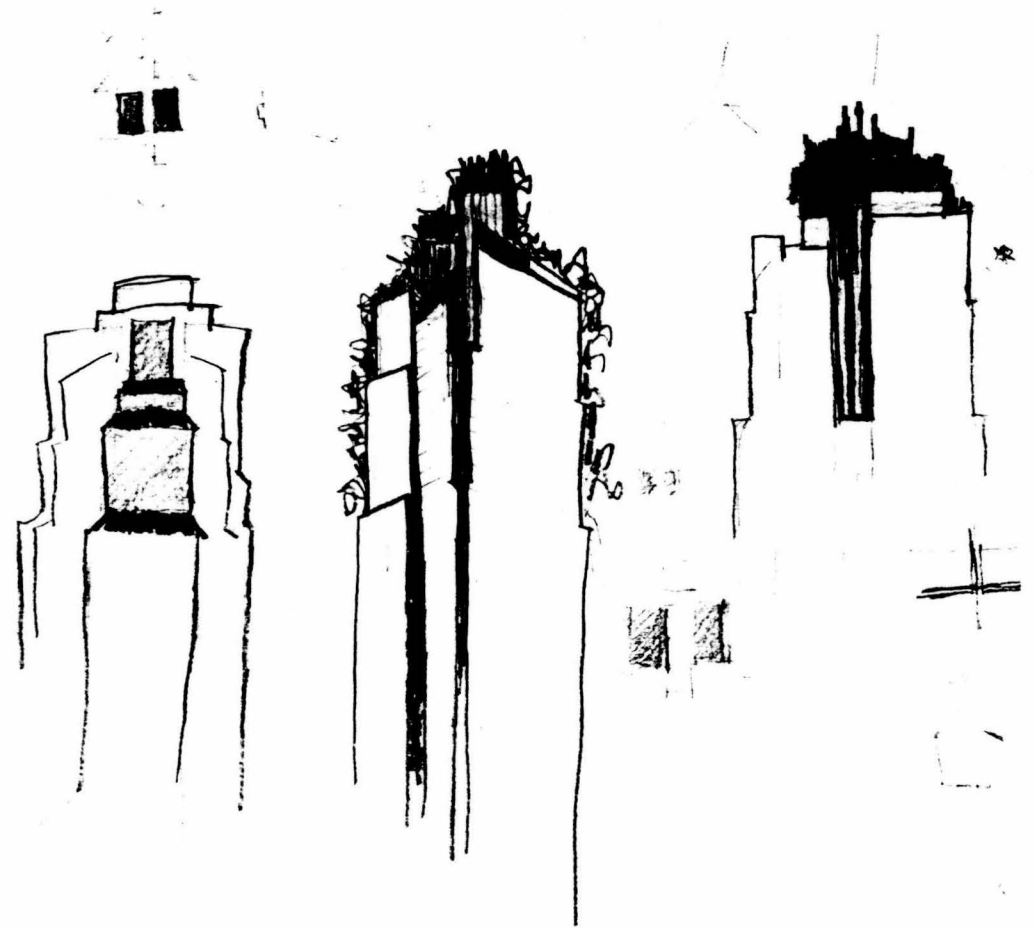

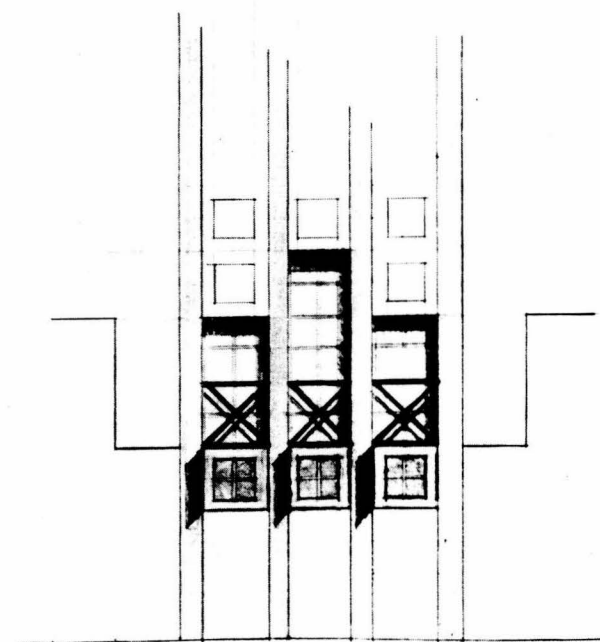
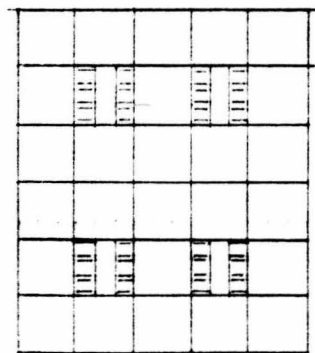
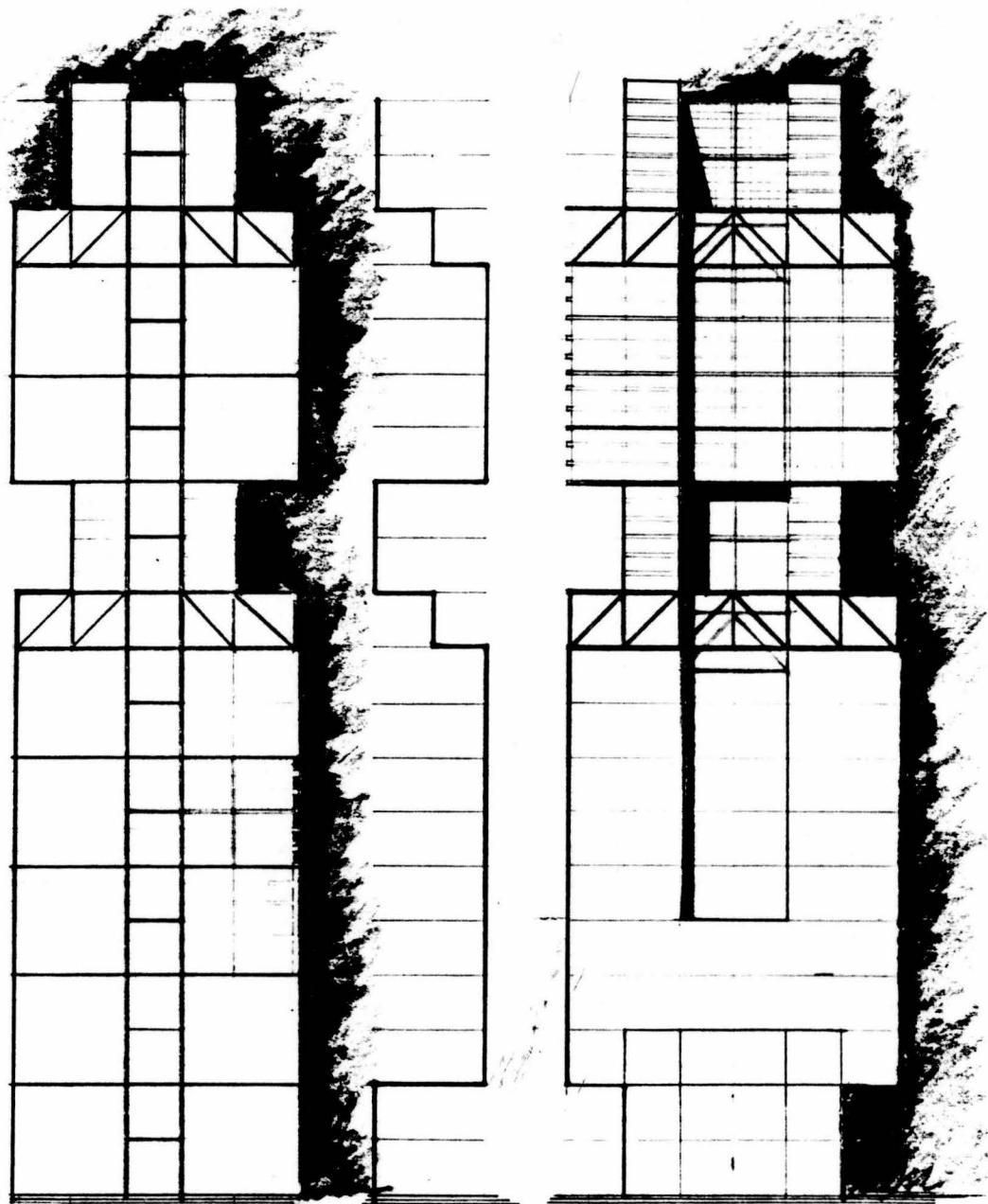

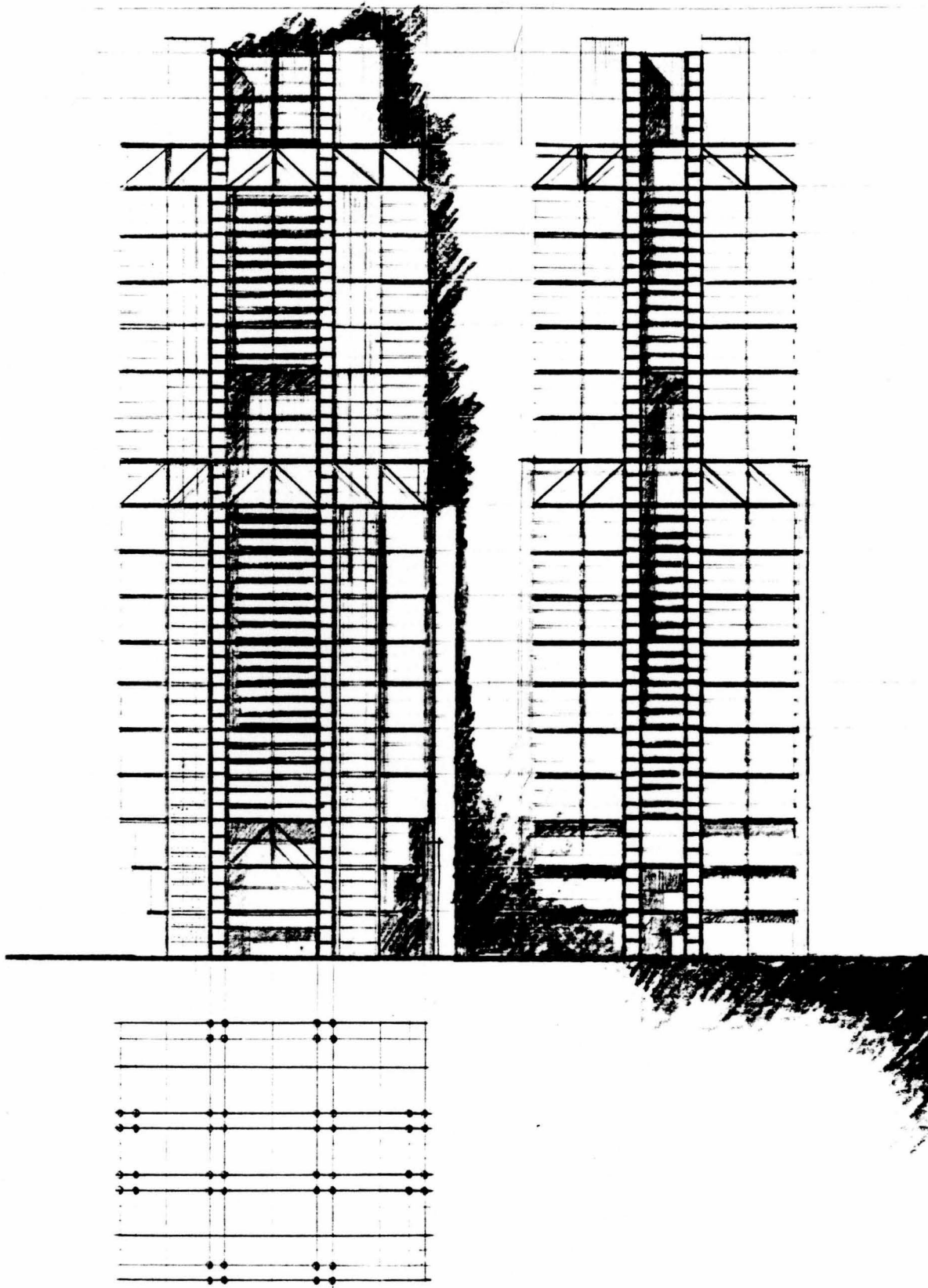

A beacon for memory  
A greeting to morning incoming  
A salute to evening exit  
A point of reference

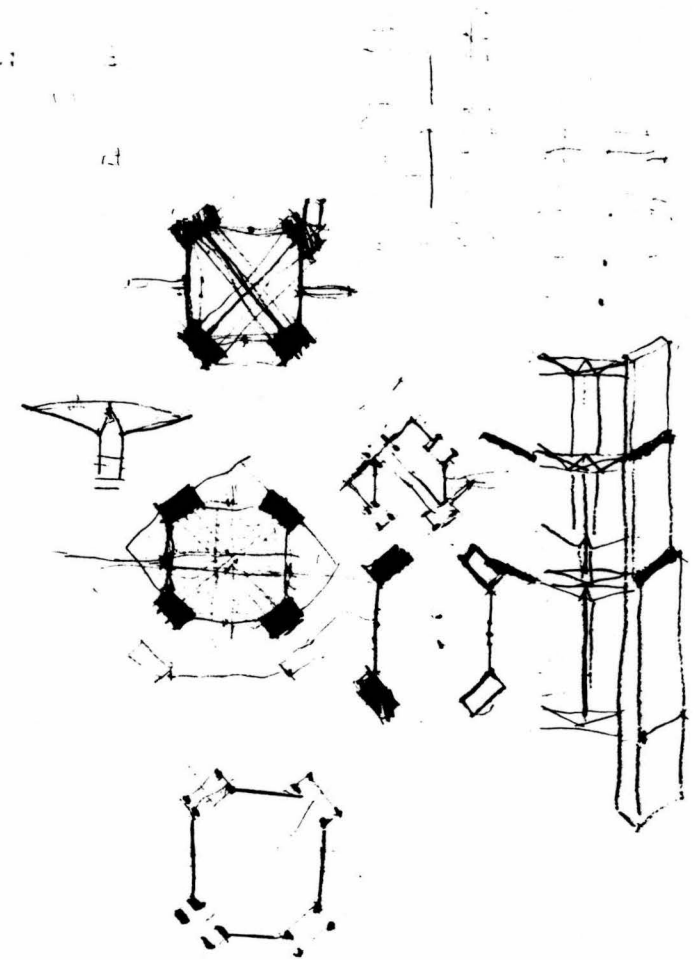

## A House of Four Views

View to the field  
A wall for livelihood  
An overlook, an axis  
Scene of the morning sunlight

View to the water  
A wall for frolic  
An oncoming, an axis  
Scene to the evening twilight

View to the forest edge  
A wall for parade  
A chasm, an axis  
Scene to the house body

A split between two souls  
For livelihood for frolic  
A garden as oncoming  
A heart for movement

A heart for movement  
Columns and stairs  
Views to space and light  
Scene to the sky

A split between two souls  
An inbetween  
Light for frolic  
Space for livelihood

A view to the south  
A view to the north  
A view to the east  
A view to the west

Two intersecting lines of four directions

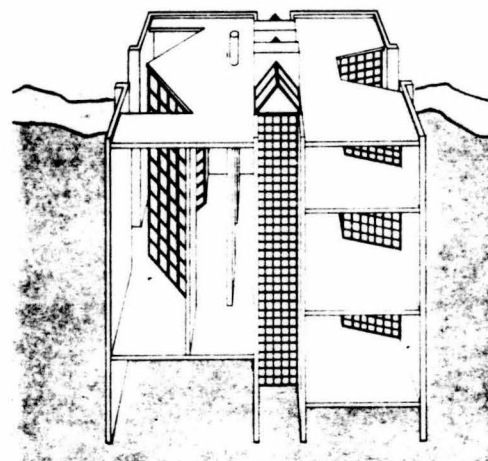
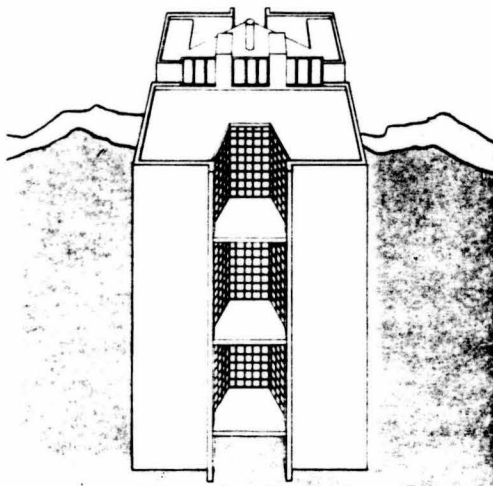
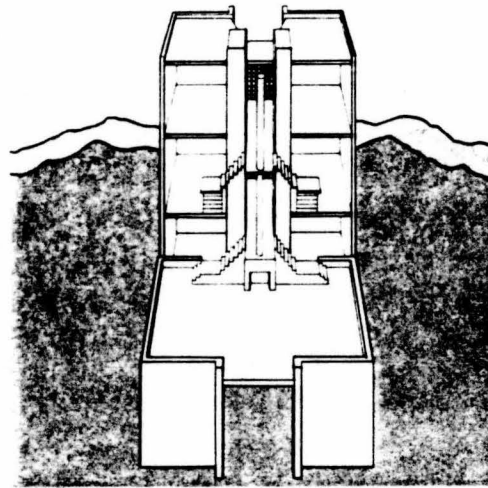
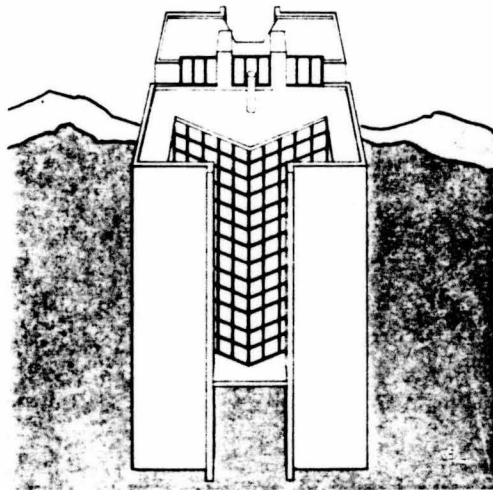

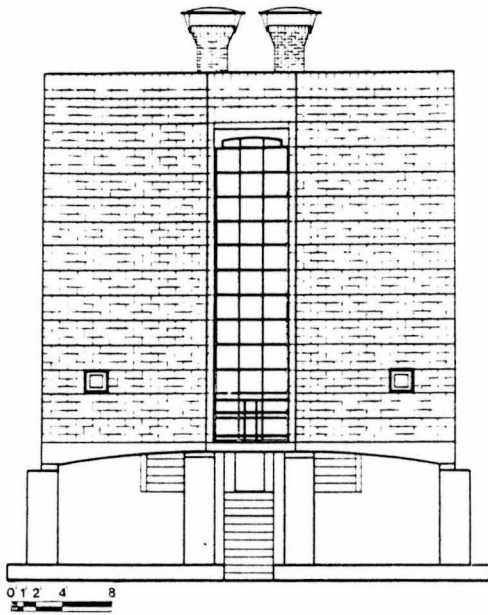

A view to the west

View to the water  
 A wall for frolic  
 An oncoming, an axis  
 Scene to the evening twilight

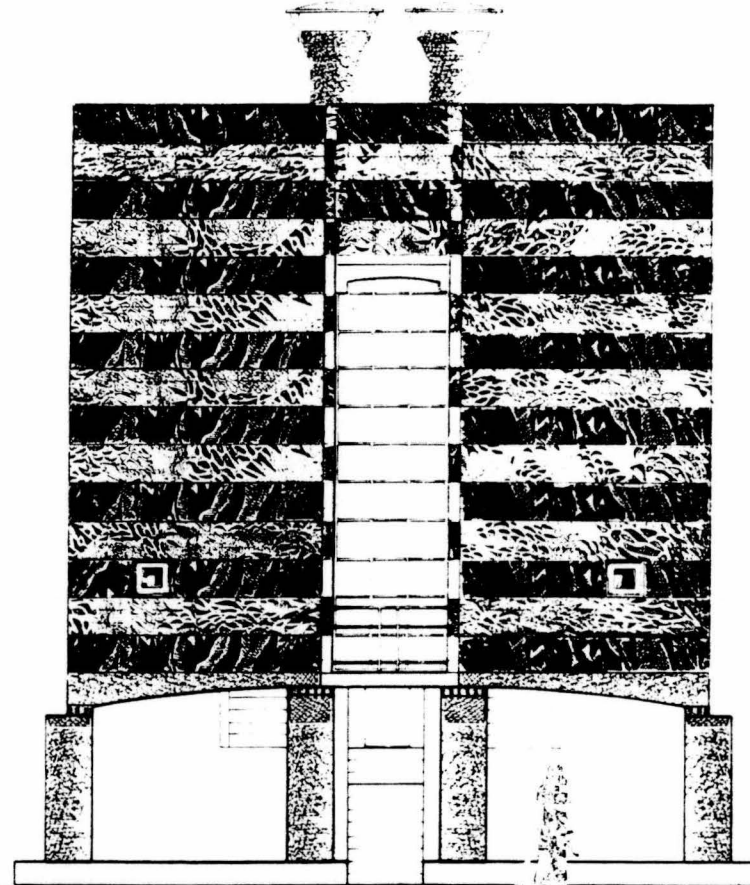



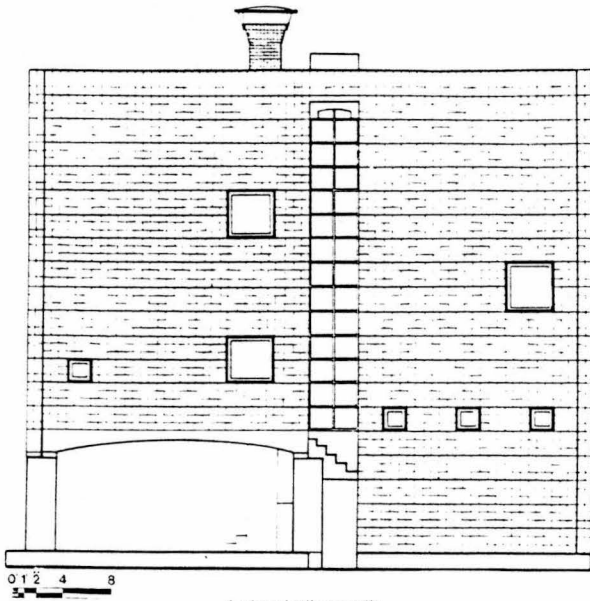

A view to the south

View to the forest edge  
 A wall for parade  
 A chasm, an axis  
 Scene to the house body

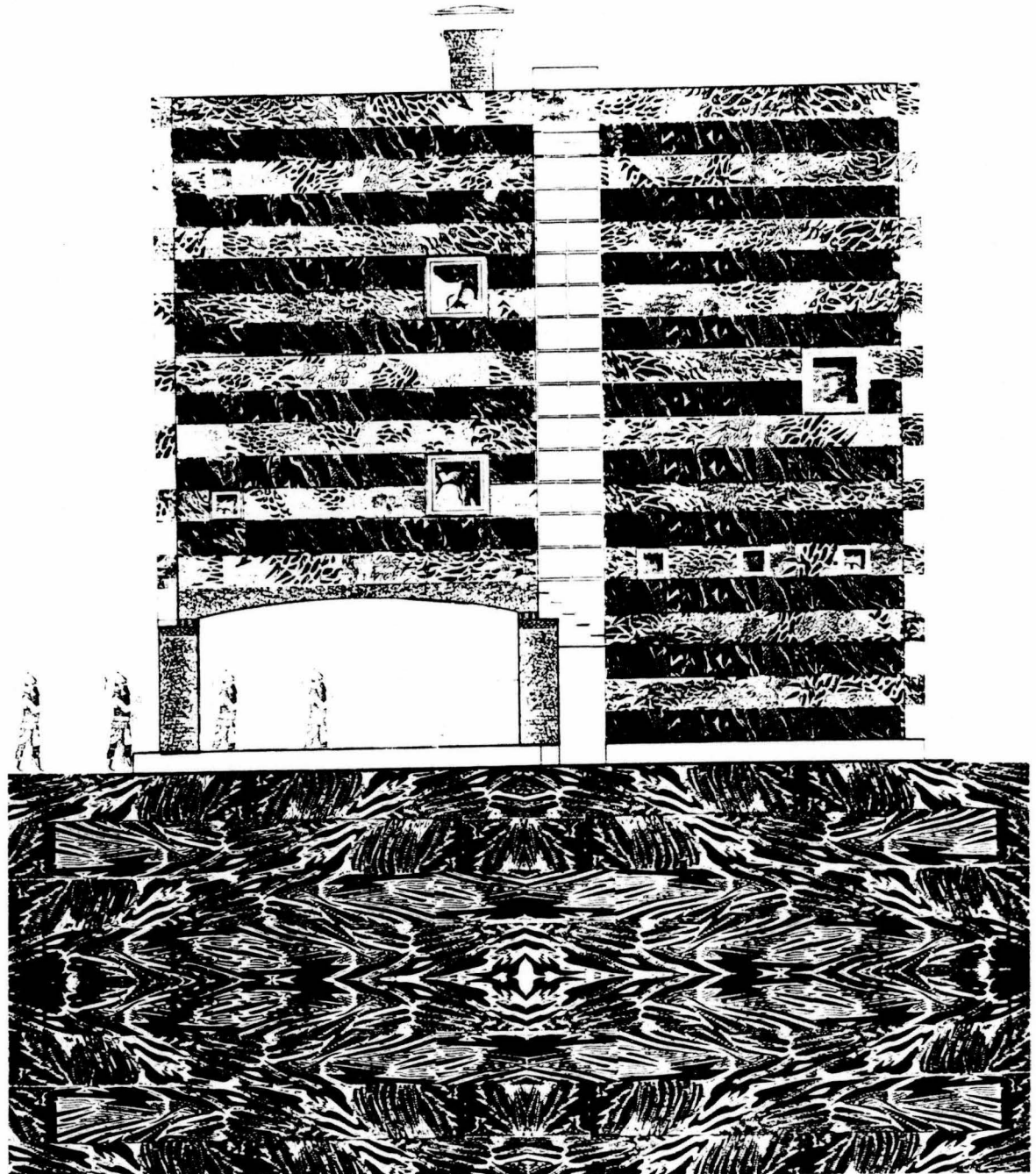

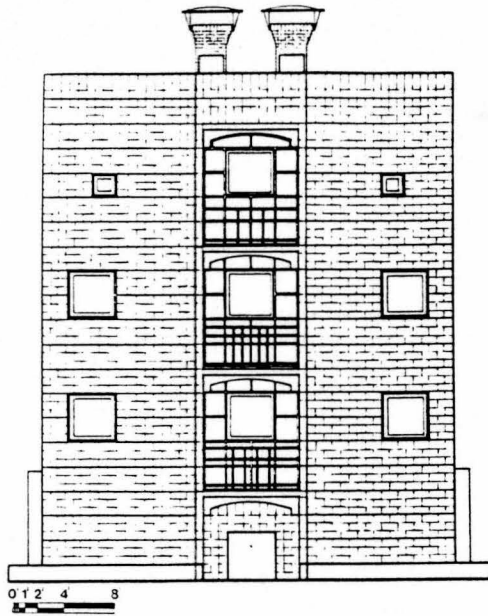

A view to the east

View to the field  
 A wall for livelihood  
 An overlook, an axis  
 Scene of the morning sunlight

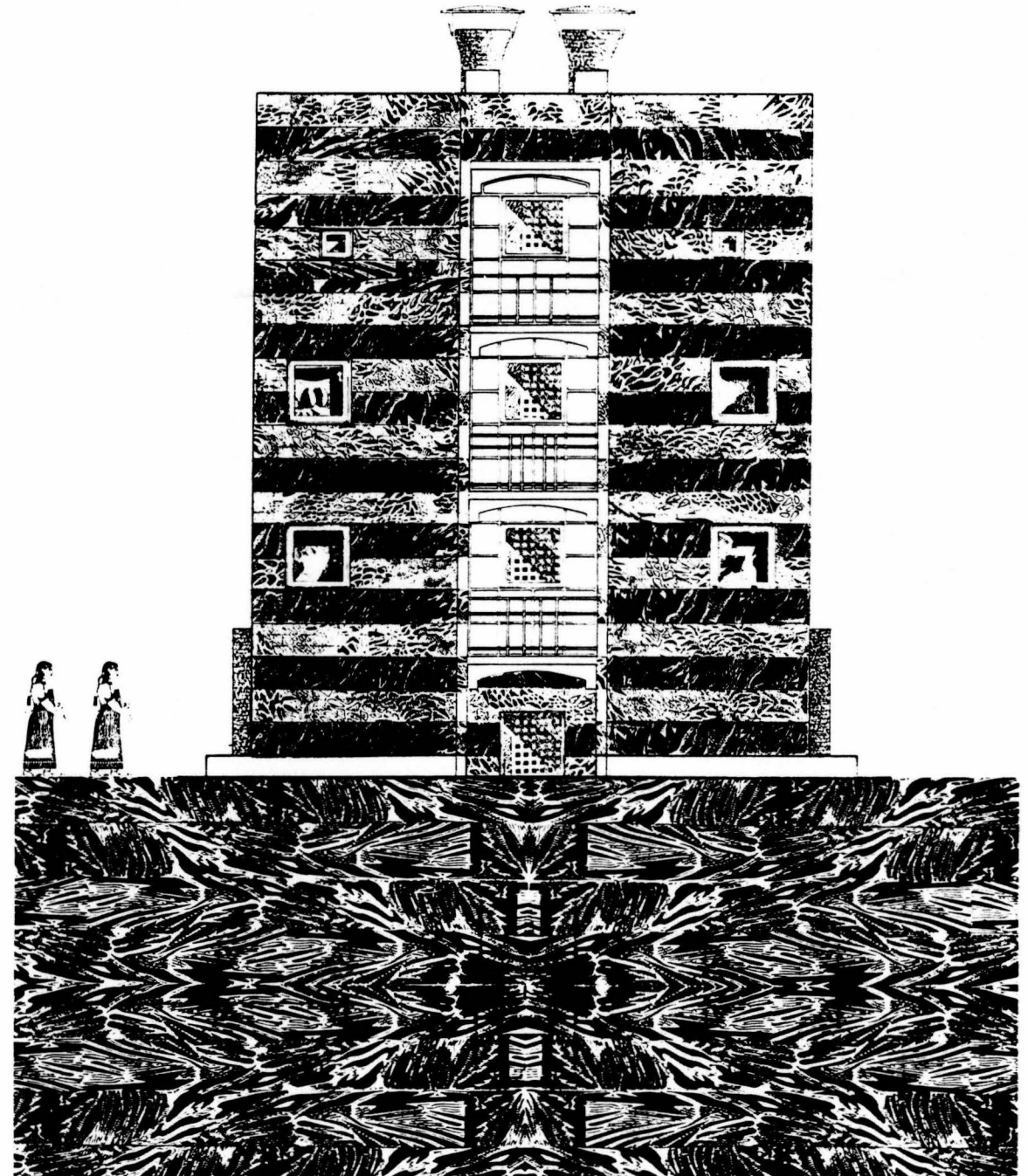



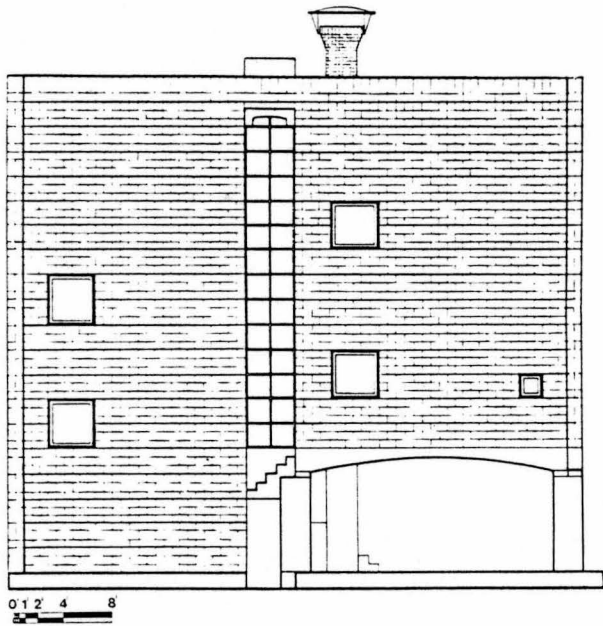

A view to the north

View to the forest edge  
 A wall for parade  
 A chasm, an axis  
 Scene to the house body

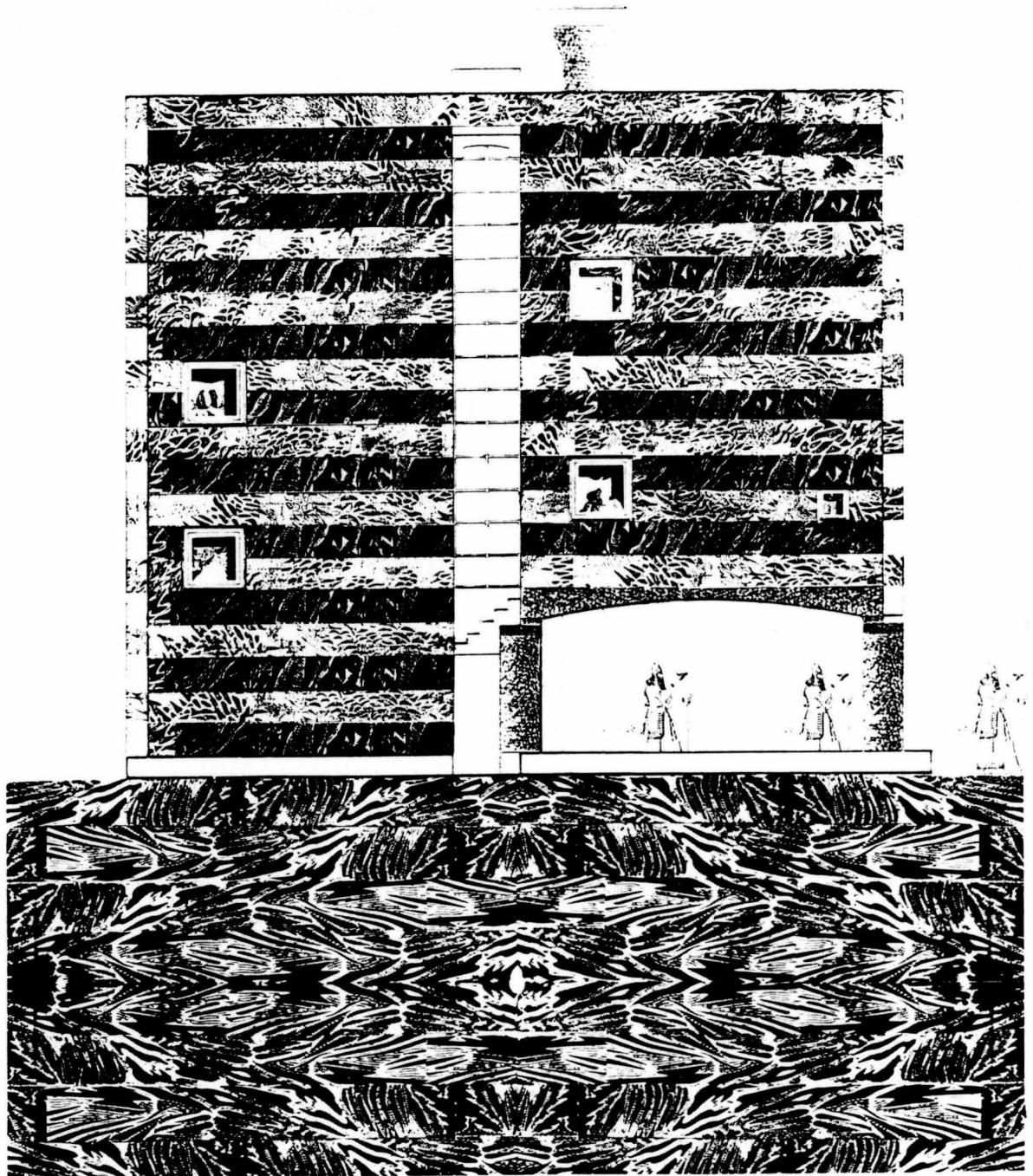

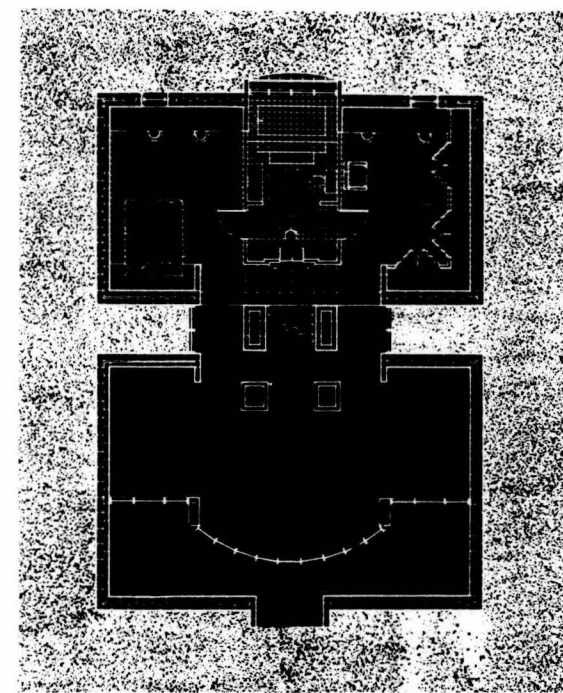
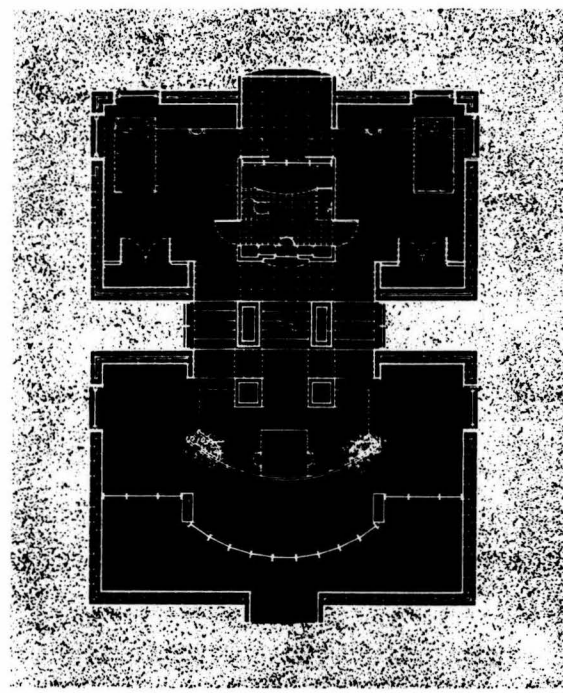
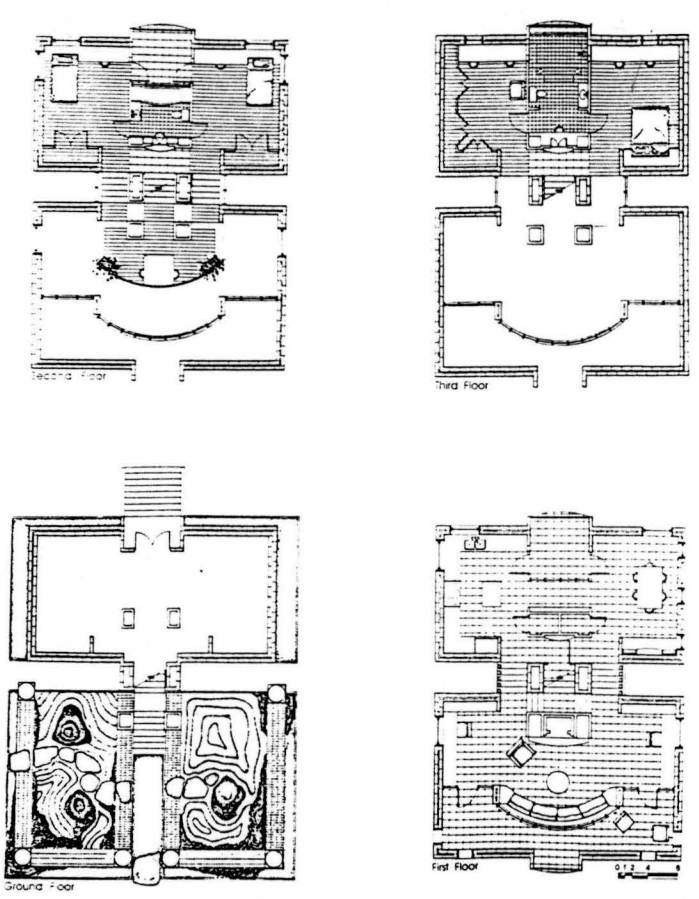

A split between two souls  
 For livelihood for frolic  
 A garden as oncoming  
 A heart for movement

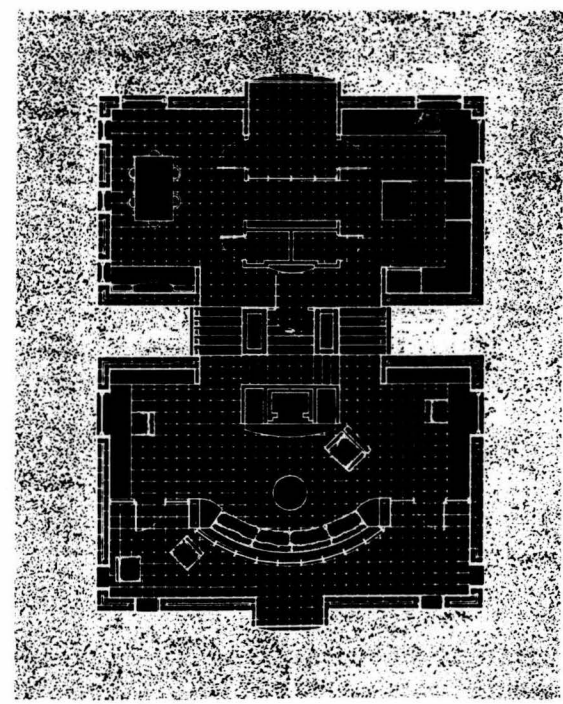
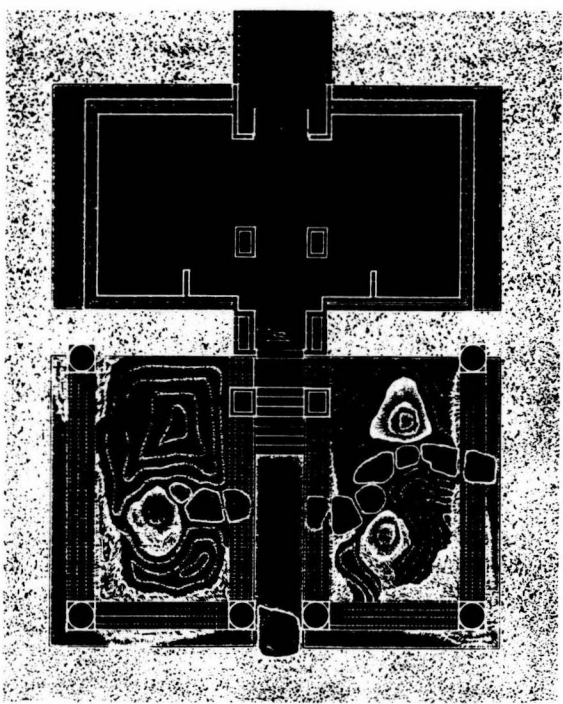

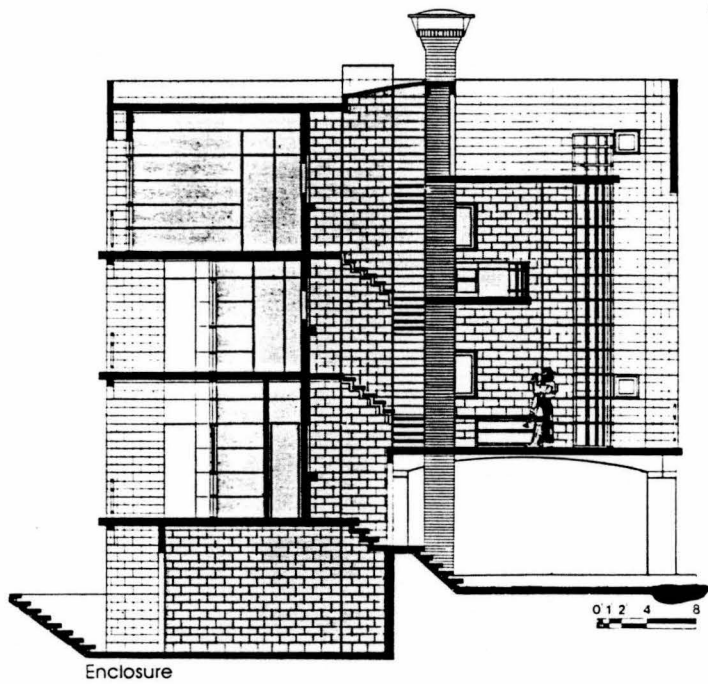

A split between two souls  
An inbetween  
Light for frolic  
Space for livelihood

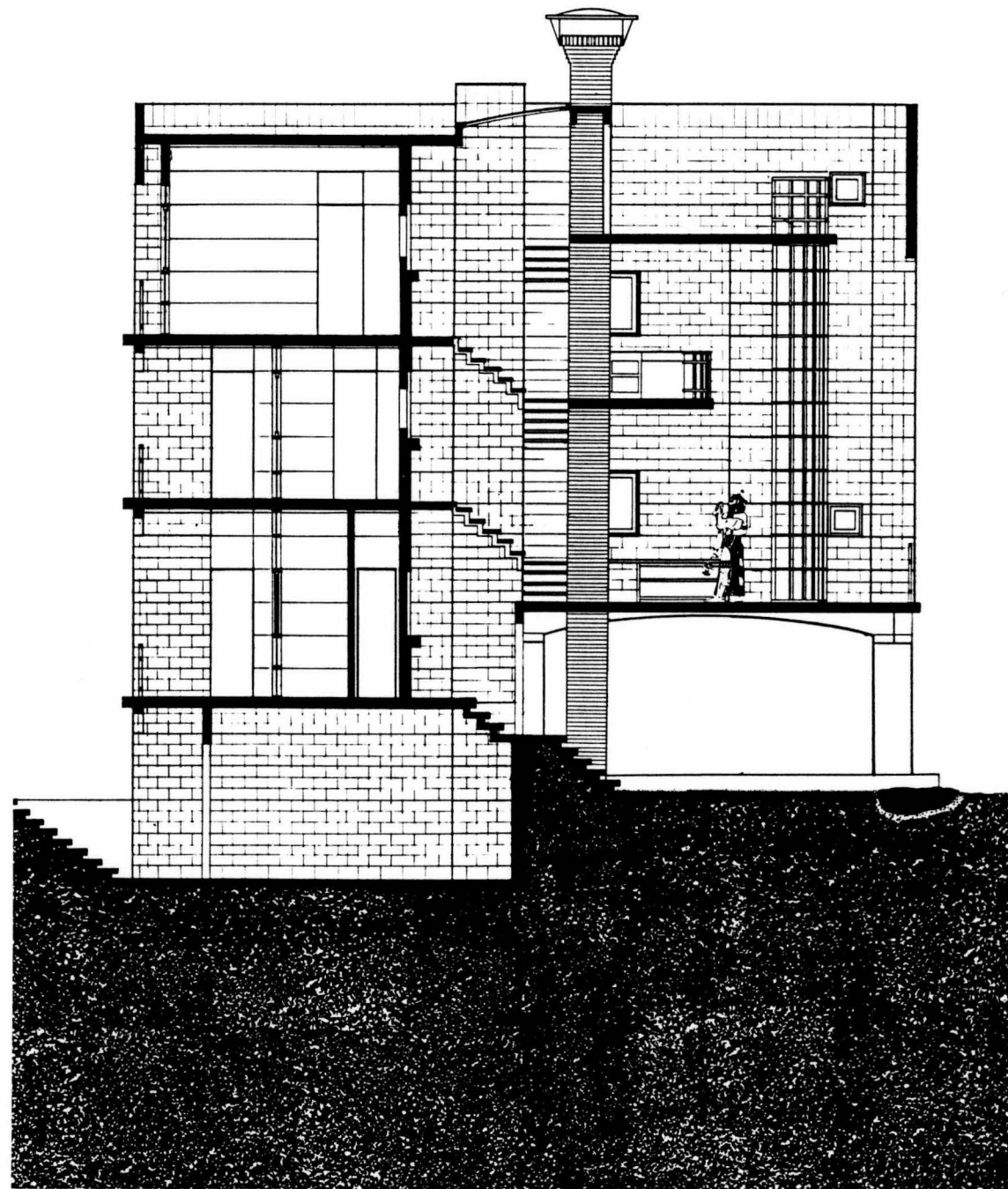



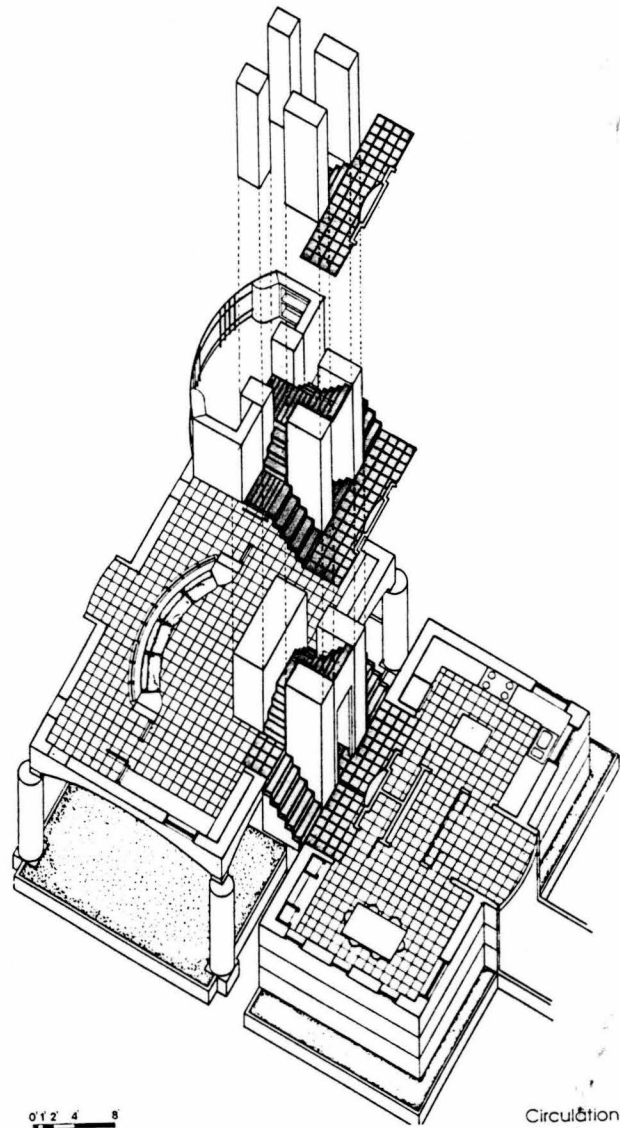

A heart for movement  
 Columns and stairs  
 Views to space and light  
 Scene to the sky

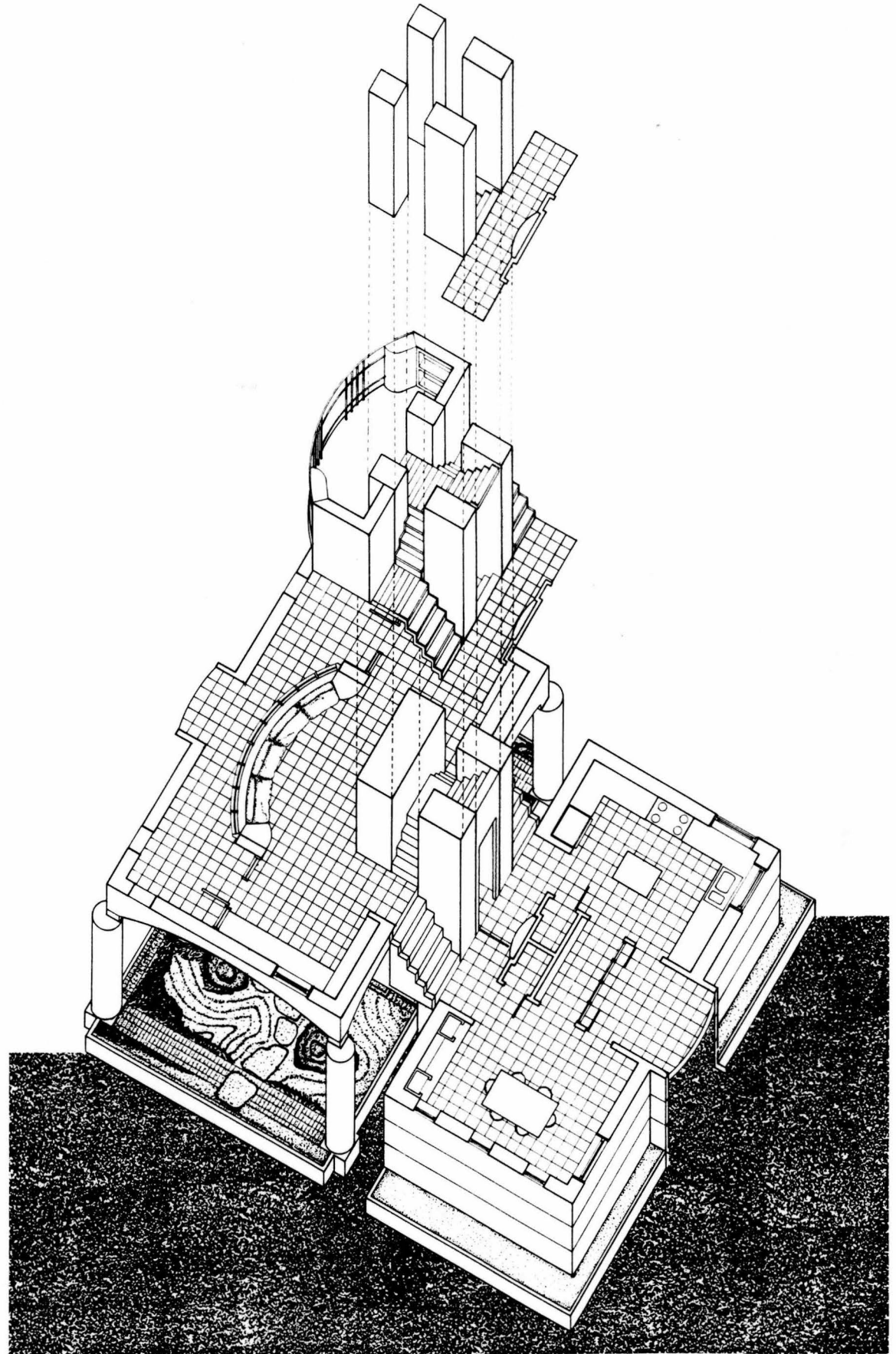

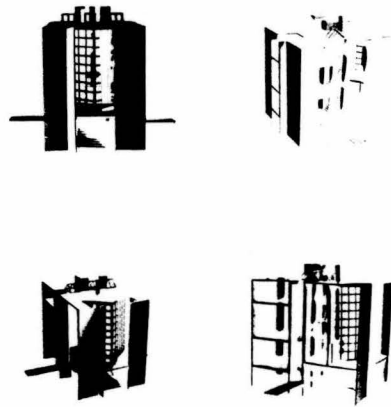

A view to the south  
A view to the north  
A view to the east  
A view to the west

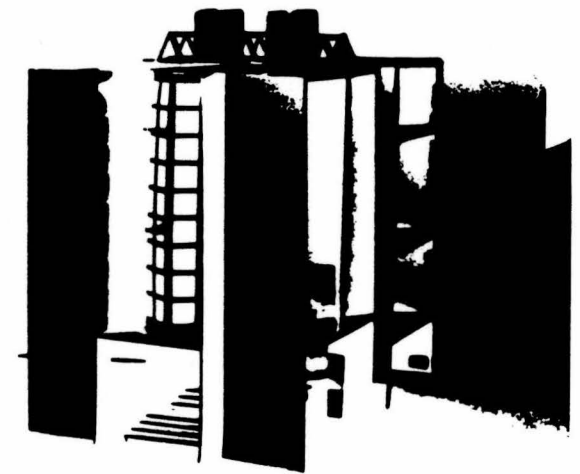
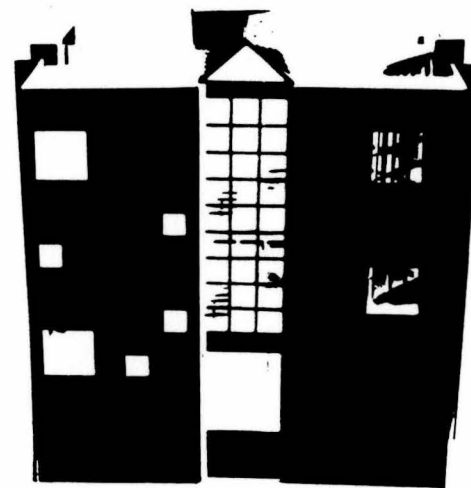
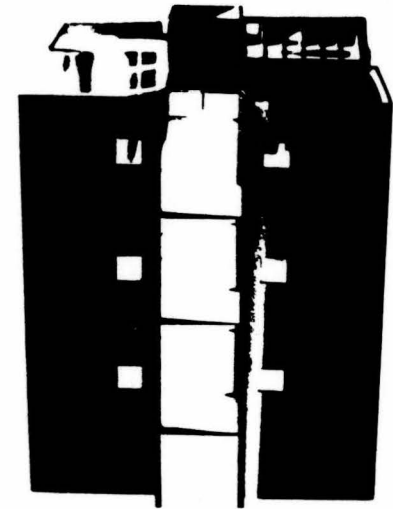
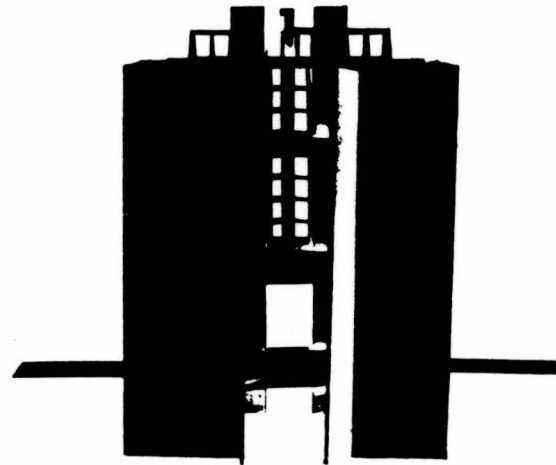

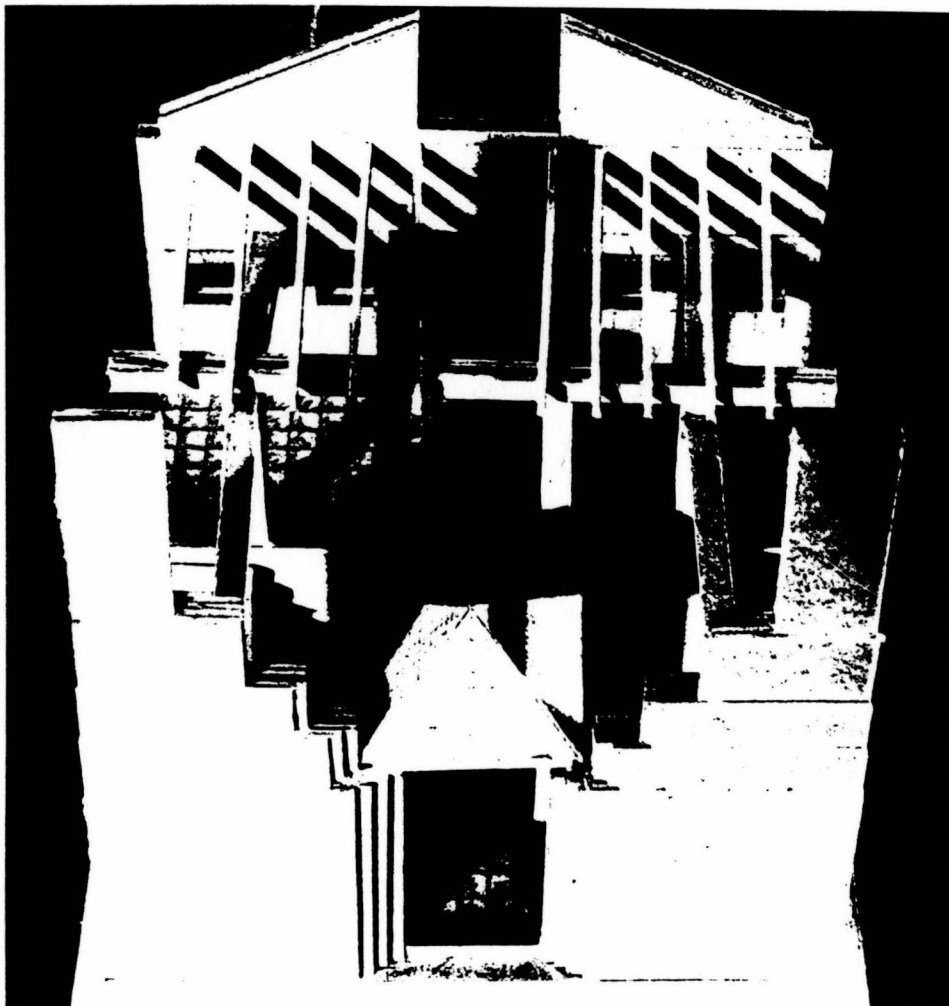

## A House of Columns

A wall to the street  
Holding a garden  
A court, a porch  
Presenting ingress

A wall to the alley  
Holding a garden  
A yard, a patio  
Presenting egress

An axis

A series of walls  
A field of columns  
A sequence of courts  
A procession, a ritual

A house for books  
Places to read  
To study  
A walkway to pace  
Contemplation

A grand room  
Columns and books  
End to an axis  
Trusses and light

A space between two parallel lines

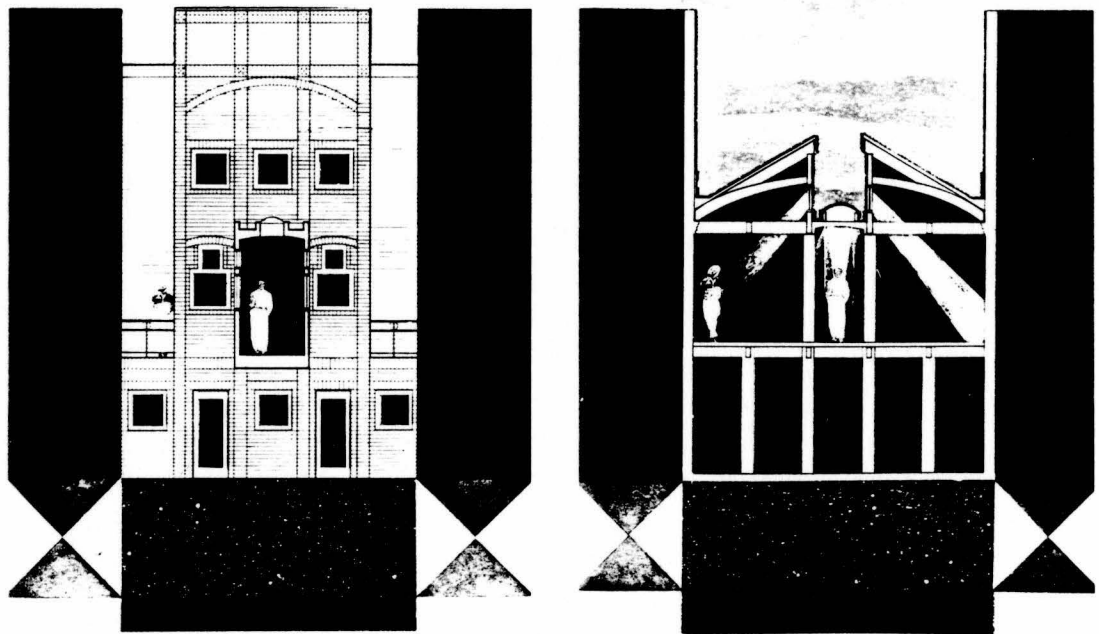
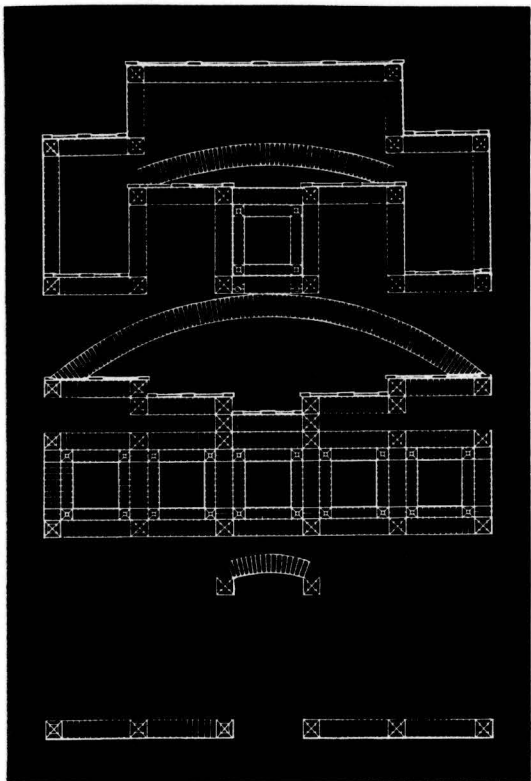
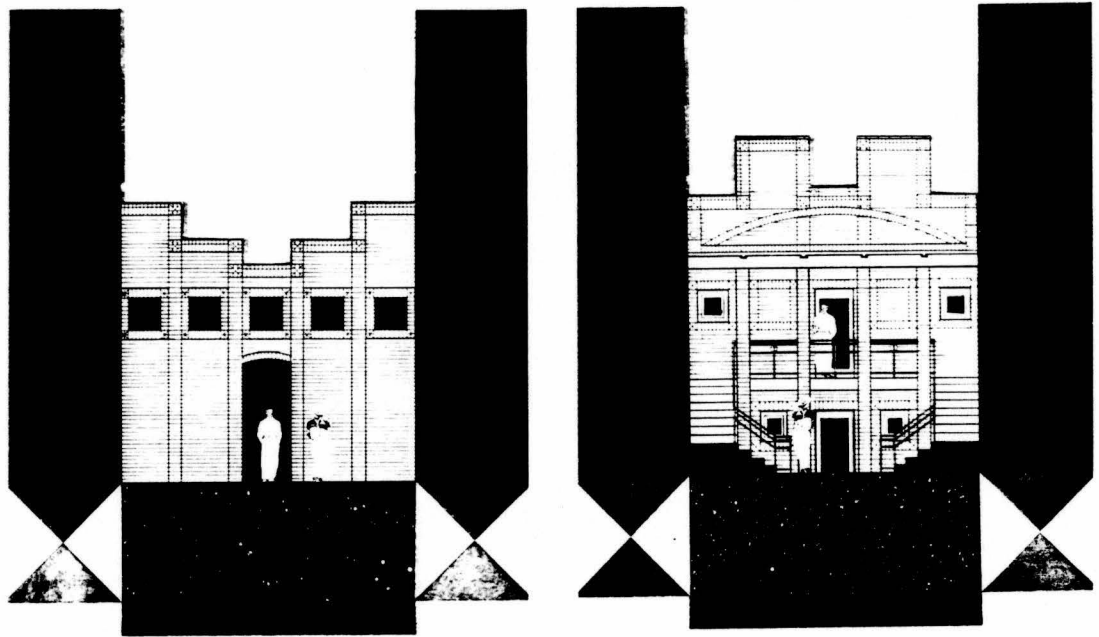

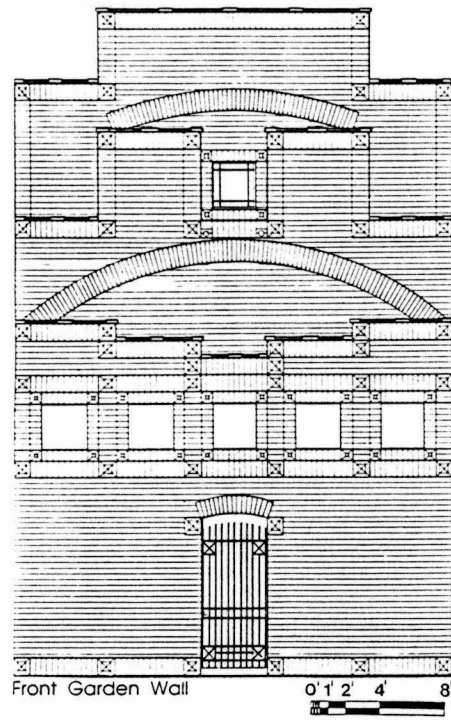

A wall to the street  
 Holding a garden  
 A court, a porch  
 Presenting ingress

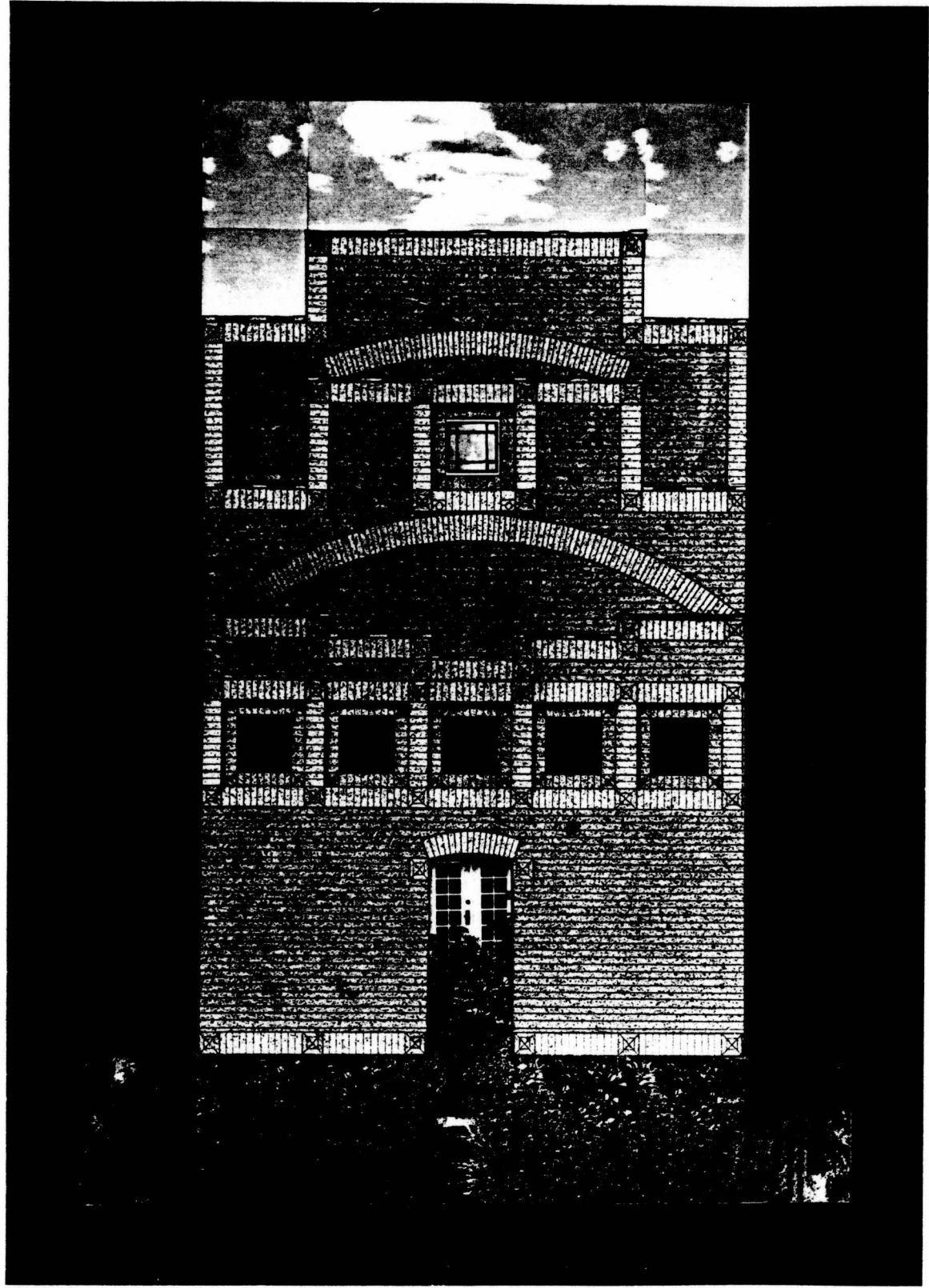



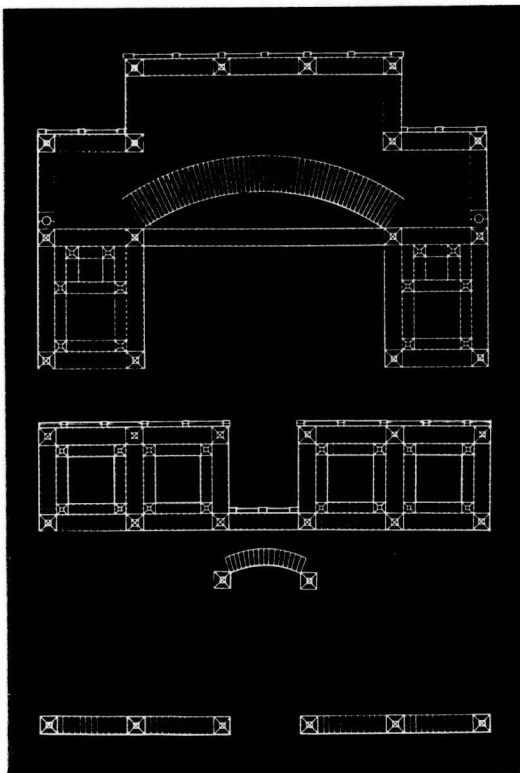
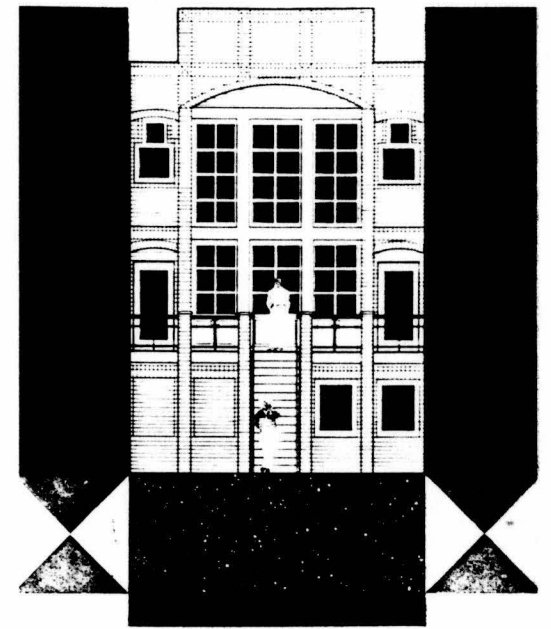
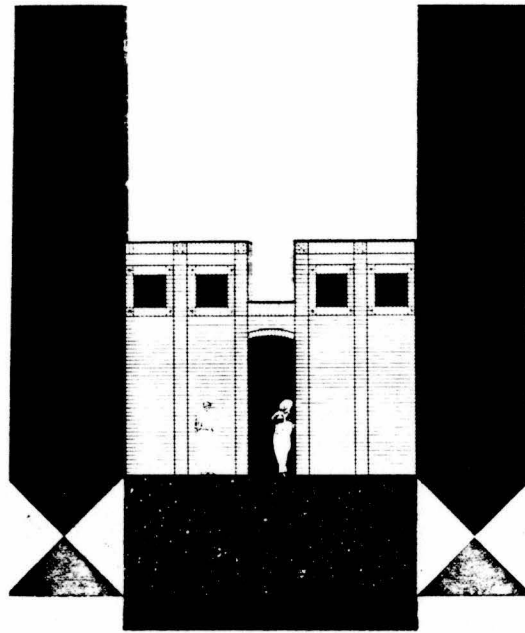

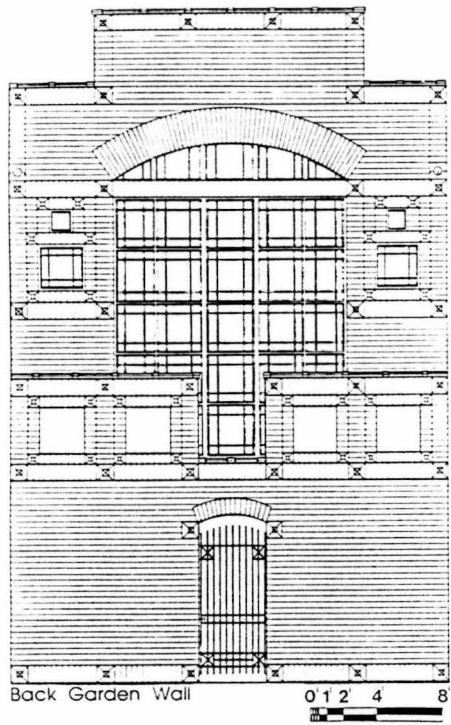

A wall to the alley  
Holding a garden  
A yard, a patio  
Presenting egress

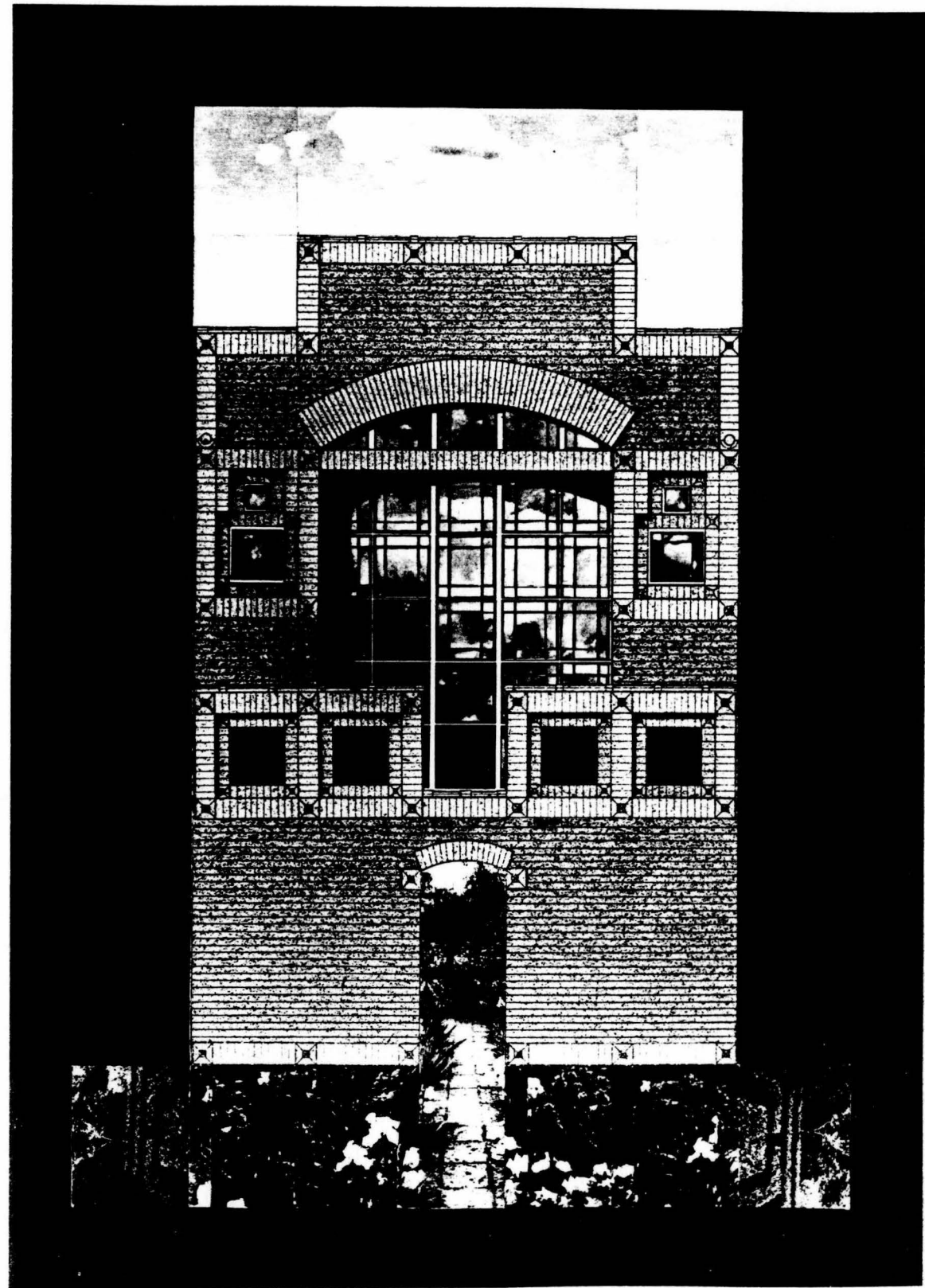

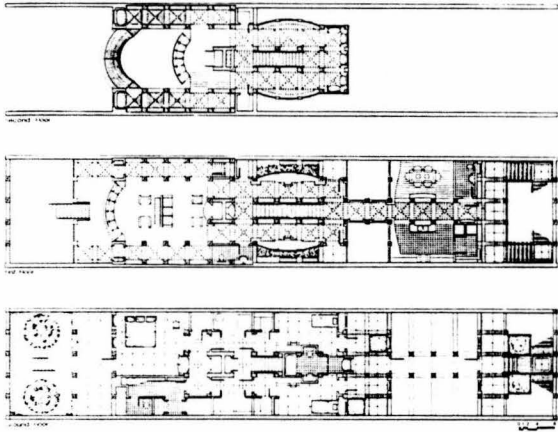

A house for books  
 Places to read  
 To study  
 A walkway to pace  
 Contemplation

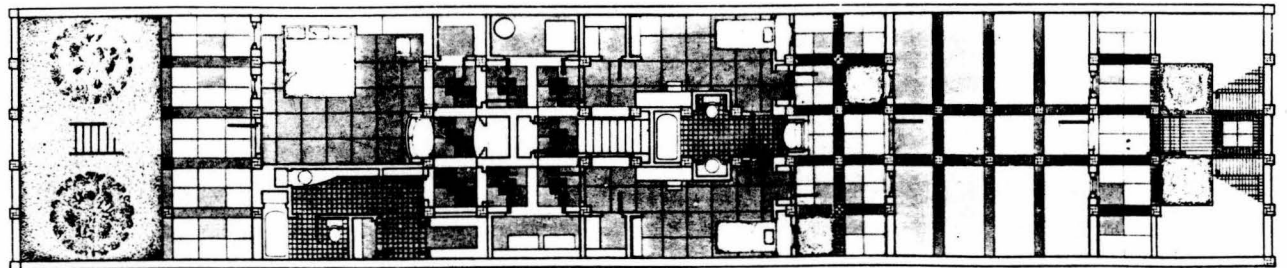
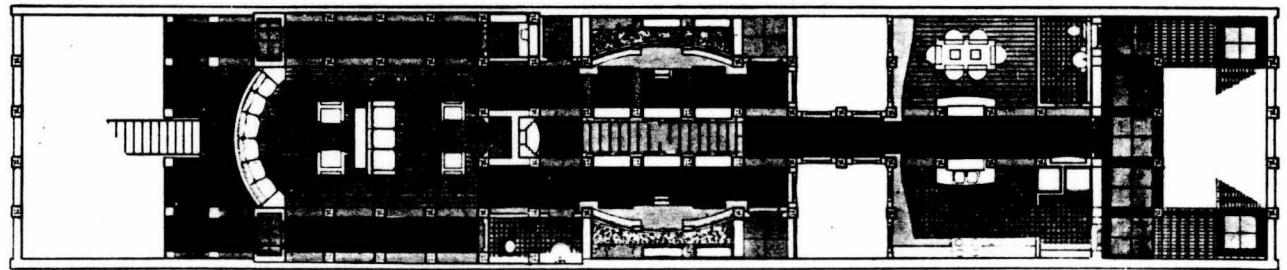
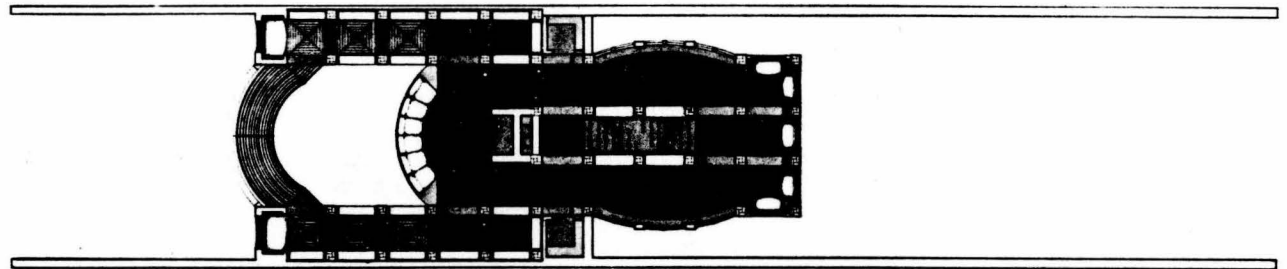
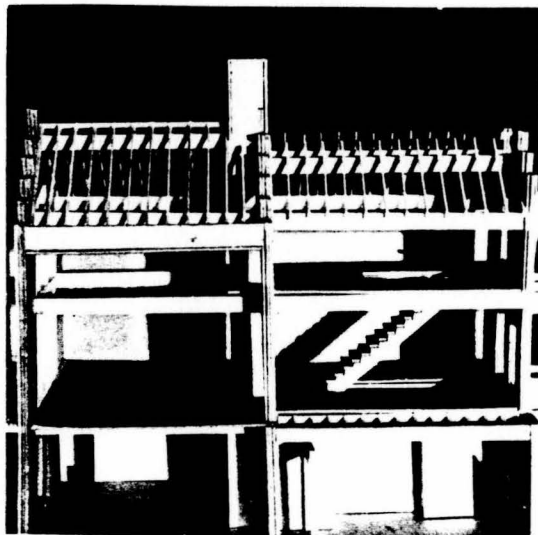

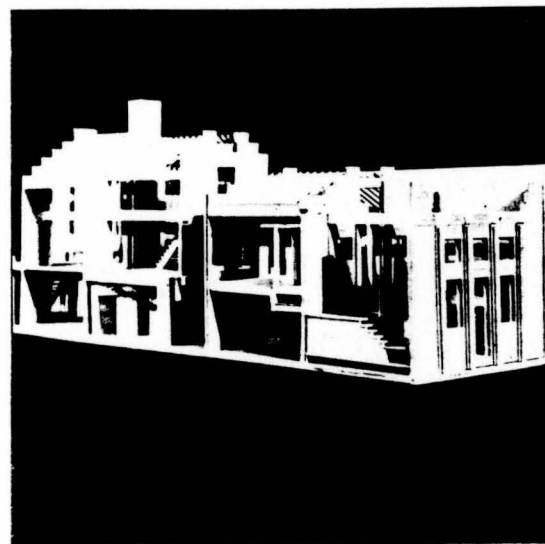

An axis  
 A series of walls  
 A field of columns  
 A sequence of courts  
 A procession, a ritual

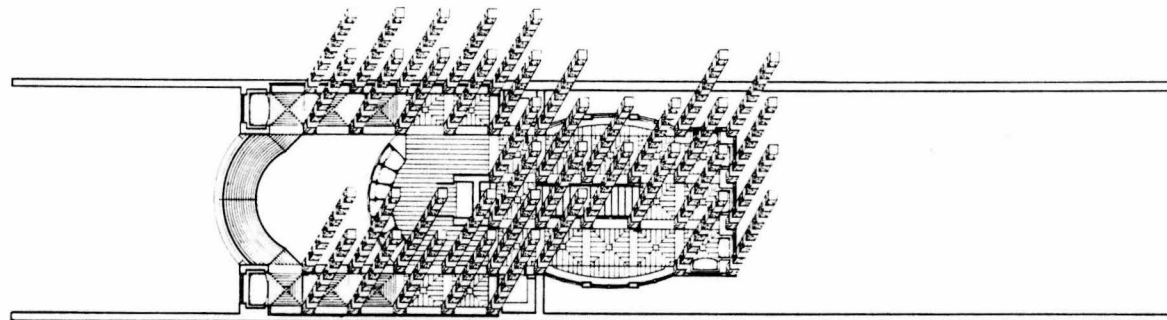
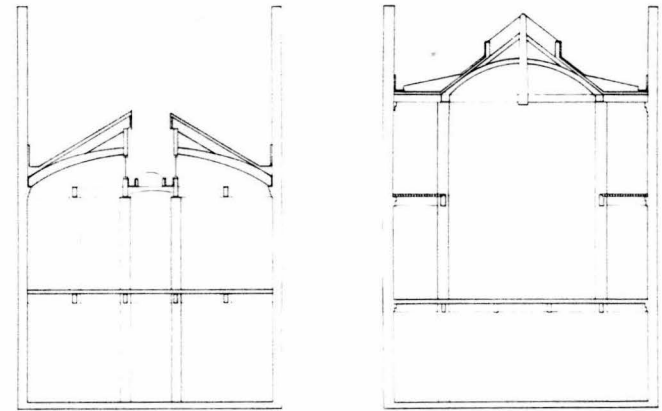

Second

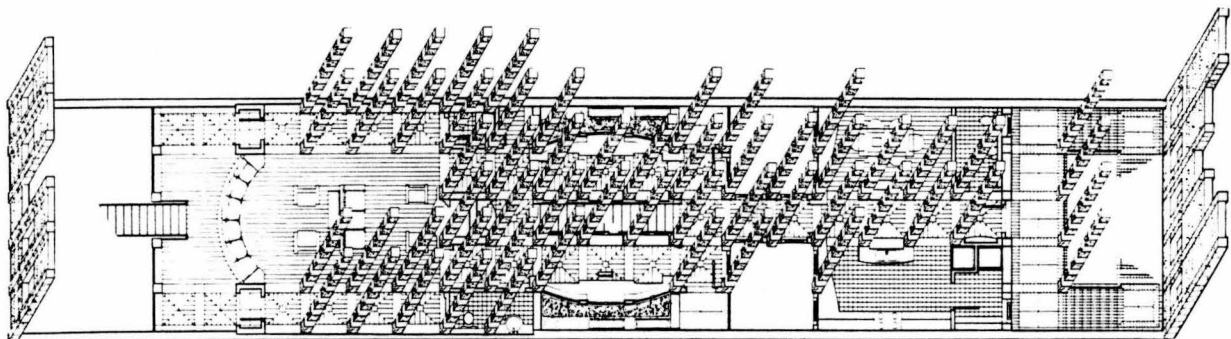

First

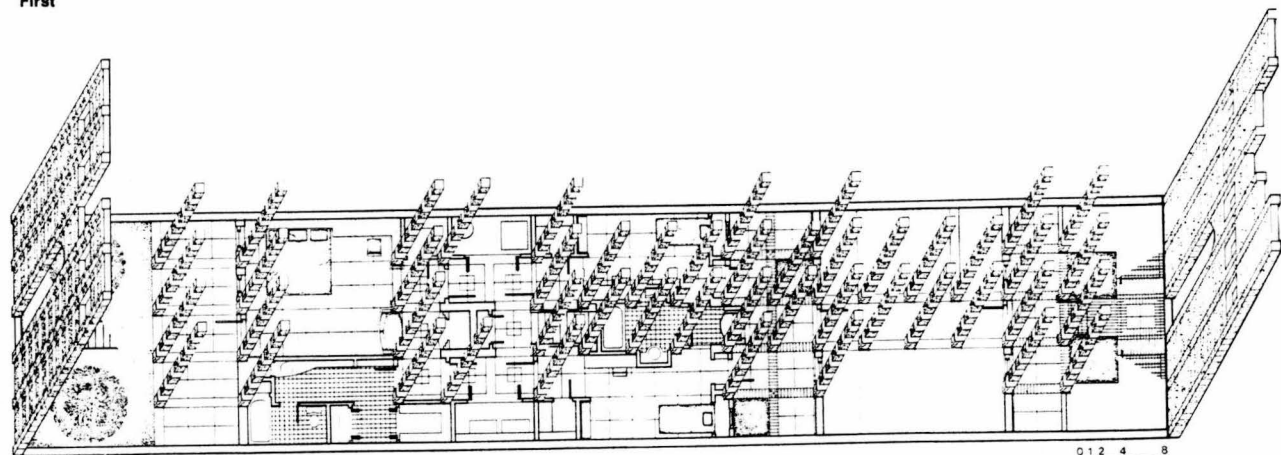

Ground

0 1 2 4 8

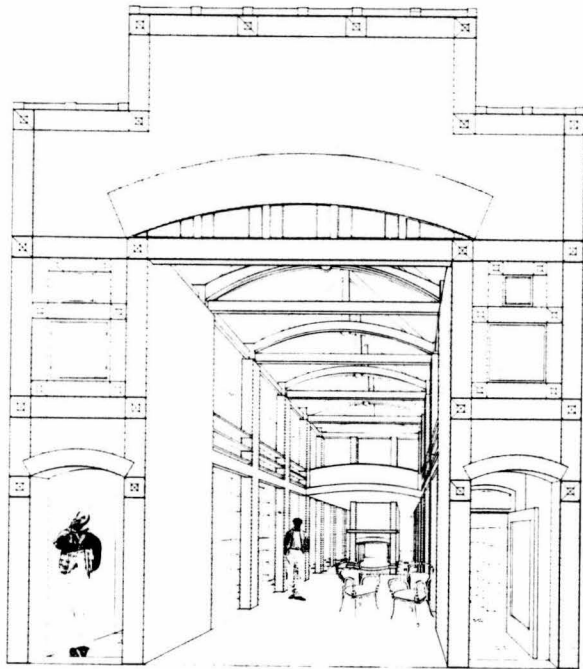

A grand room  
Columns and books  
End to an axis  
Trusses and light

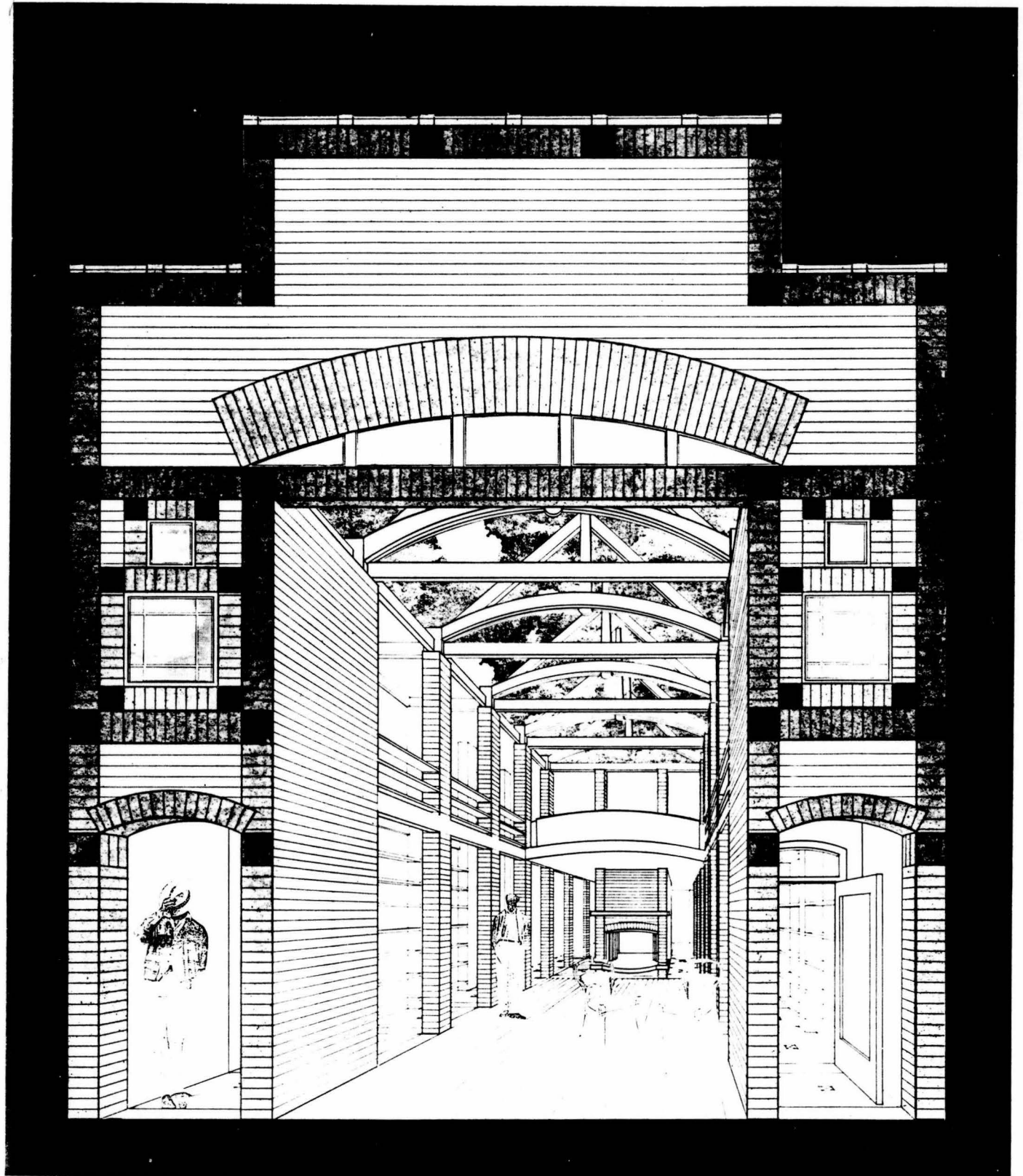



A Wall as Gate

A building making a wall  
A barrier  
Between town and campus  
A series of gates

A split of two functions:

A series of libraries  
Addressing a town  
Passing cars  
Acting as a billboard  
An entry gate

A series of living spaces  
Reacting to a campus  
Passing students  
Acting as enclosure  
An exit gate

A wall of information  
Clues to its contents  
A series of images  
A reading of history

A line makes a wall

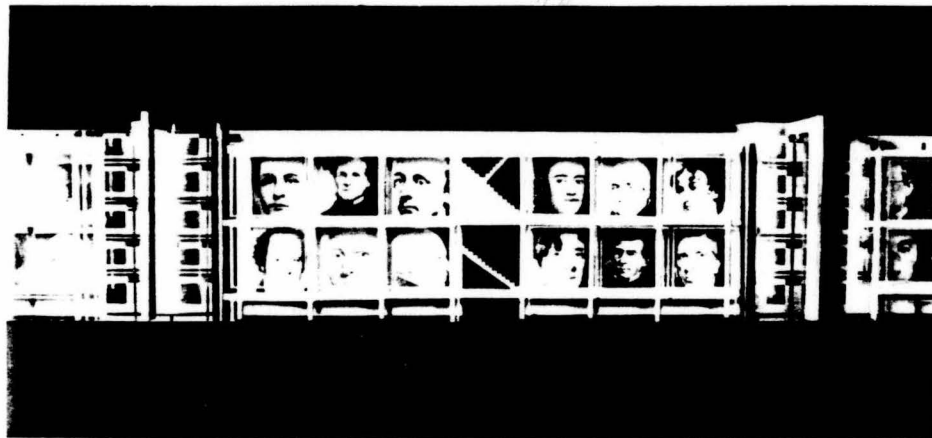



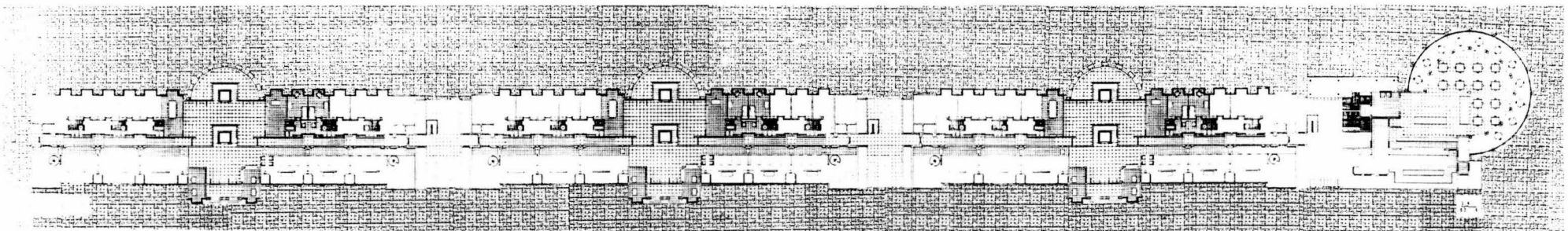
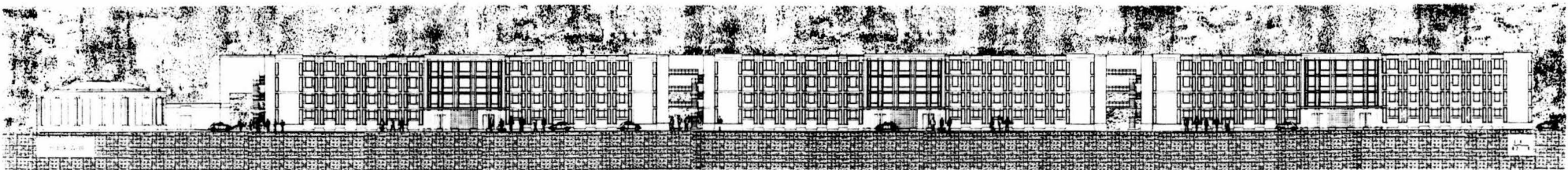
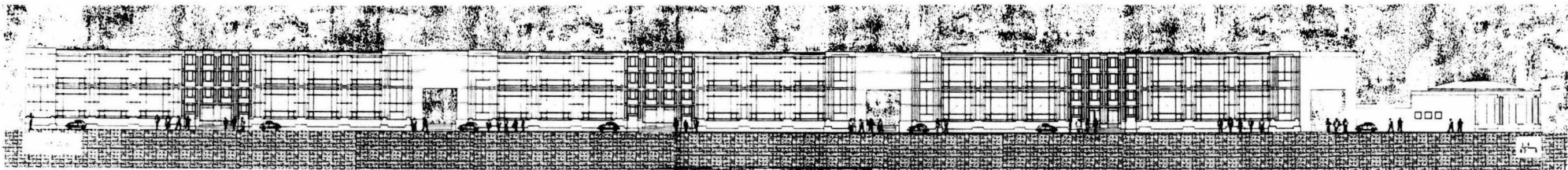
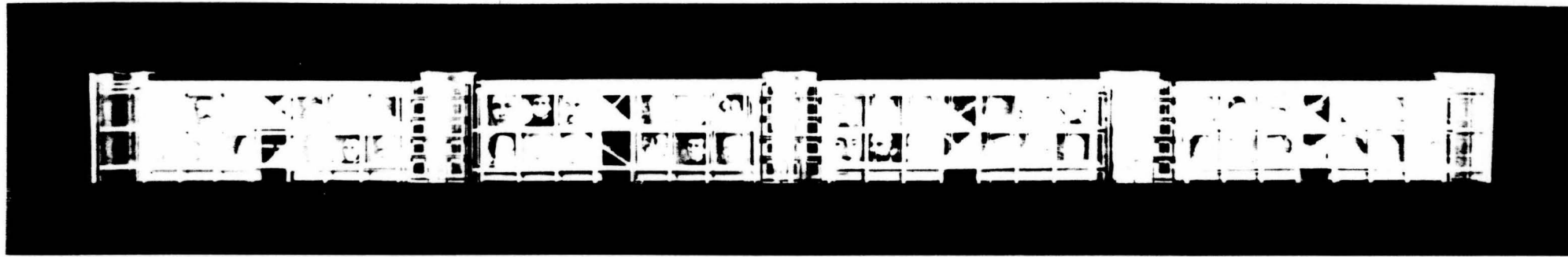

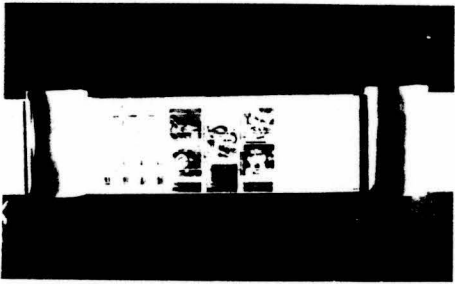
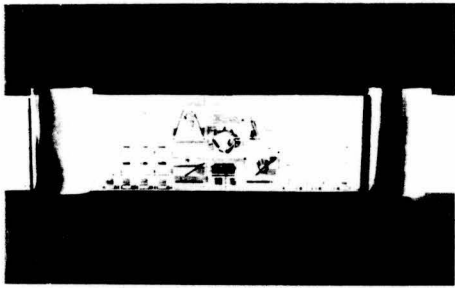

A wall of information  
Clues to its contents  
A series of images  
A reading of history

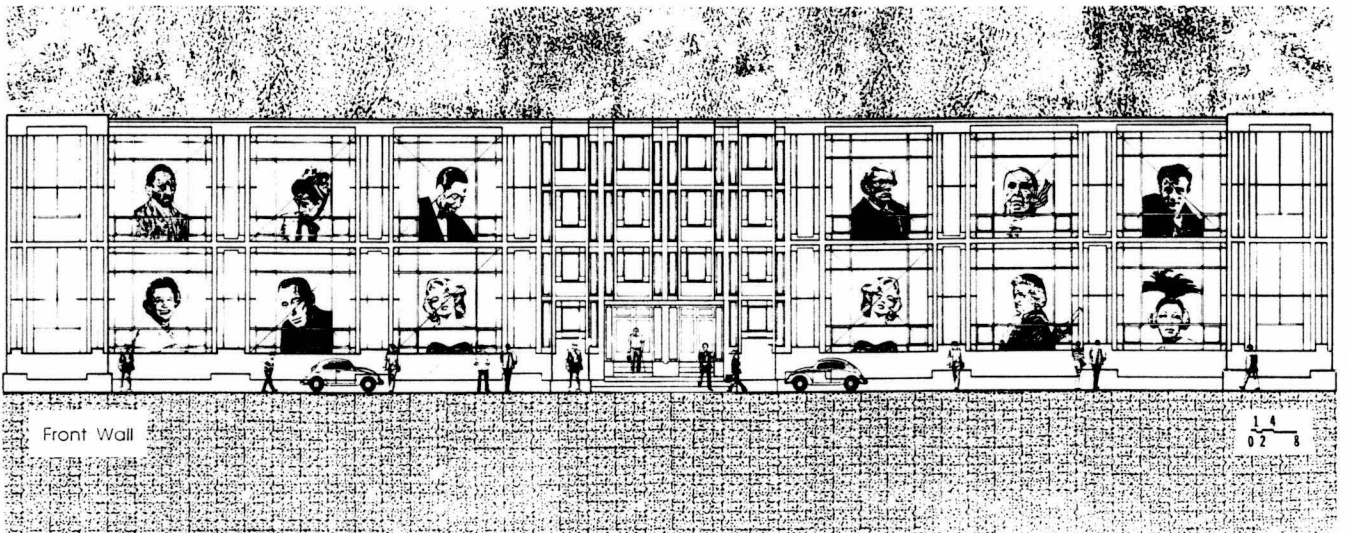
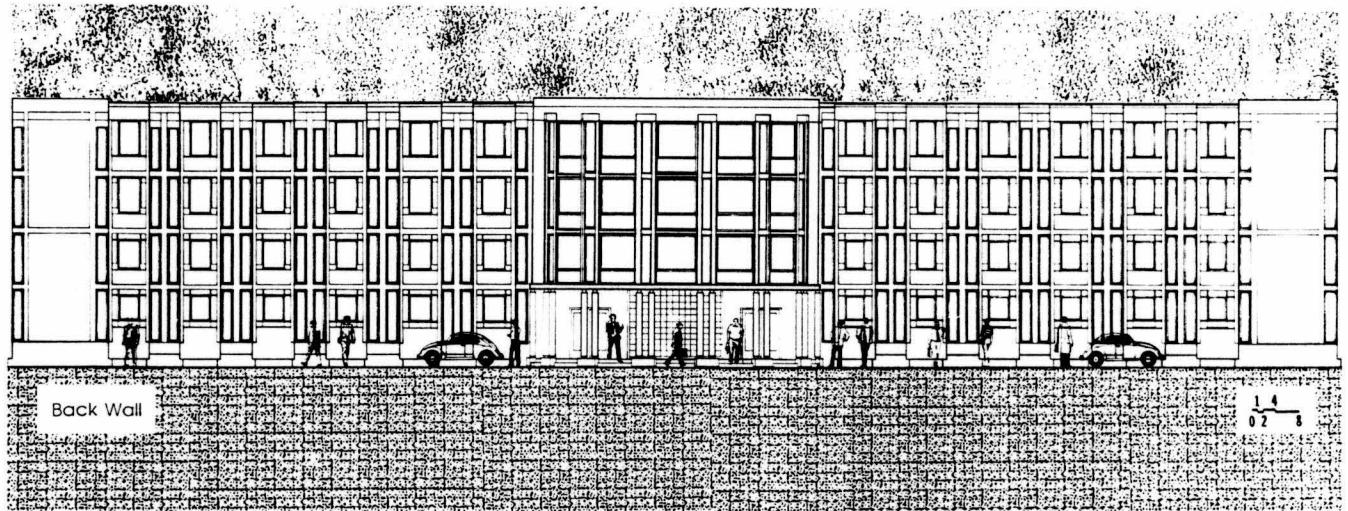
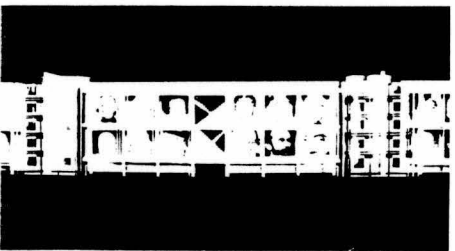



A split of two functions:

A series of libraries  
 Addressing a town  
 Passing cars  
 Acting as a billboard  
 An entry gate

A series of living spaces  
 Reacting to a campus  
 Passing students  
 Acting as enclosure  
 An exit gate

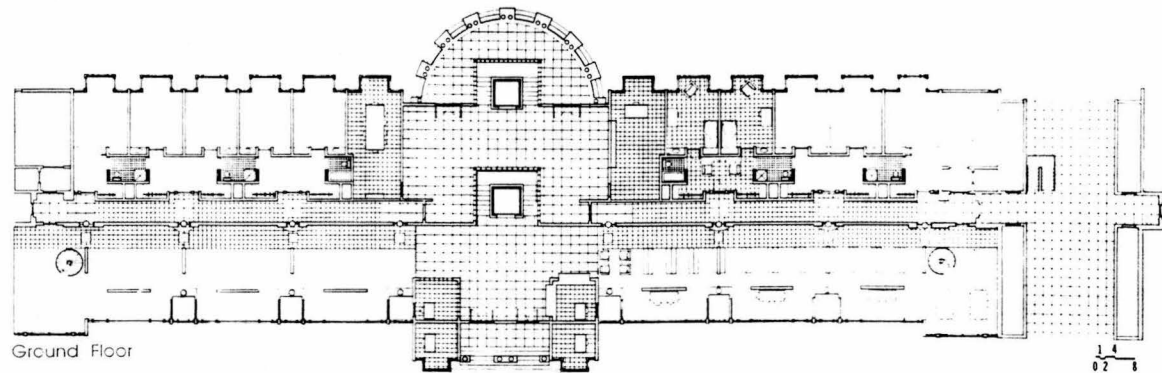
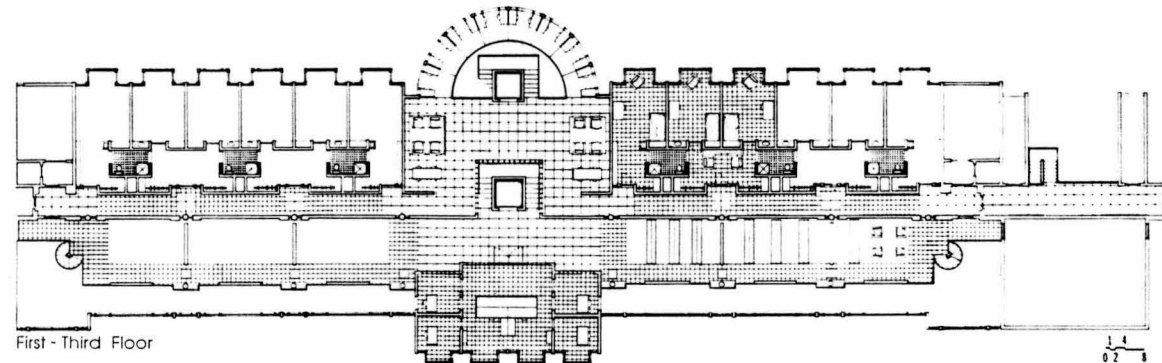
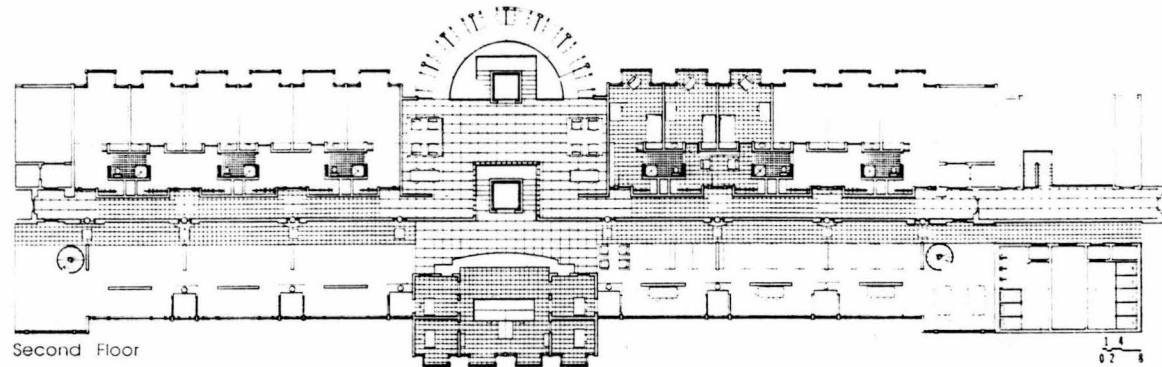

**The vita has been removed from  
the scanned document**

## ■ BIBLIOGRAPHY

### ■ The Introductory Statement was borrowed from & influenced by the following readings

- Kahn, Louis I: *Between silence and light*, Shambala Publications, 1979.
- Aristotle: *Nicomachean ethics*. Translated by W. D. Ross, in *Works*, vol. IX, 1925.
- Mays, Vernon, Editor: *What makes a good building*, from a series of lectures at the College of Architecture, Virginia Tech, 1987.

### ■ Other Readings:

- Rossi, Aldo: *The Architecture of the City*, M.I.T. Press, Cambridge, MA, 1982
- Hejduk, John: *Mask of Medusa*, Rizzoli Publications, New York, NY, 1985.
- *The Princeton Journal: Ritual Thematic Studies in Architecture*. Vol. One, The Princeton Architectural Press, Princeton, N.J., 1983.
- Norberg-Shulz, Christian: *The Concept of Dwelling - On the Way to Figurative Architecture*, Electra/Rizzoli, New York, N.Y., 1985.
- *The Journal of the Columbia Graduate School of Architecture: Precip 6, The Culture of Fragments*, 1985.

- "The man with insight enough to admit his limitations comes nearest to perfection."

- Goethe