

"AN ACT OF MAKING FORM"

BY

BARRY HILL LIGHT

THESIS SUBMITTED TO THE  
VIRGINIA POLYTECHNIC INSTITUTE AND STATE UNIVERSITY  
IN PARTIAL FULFILLMENT OF THE  
REQUIREMENTS  
FOR THE DEGREE OF  
MASTER OF ARCHITECTURE

APPROVED:

---

MICHAEL J. O'BRIEN

---

WILLIAM W. BROWN

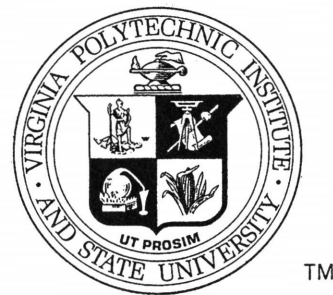

---

BENJAMIN H. EVANS

SEPTEMBER 1992  
BLACKSBURG, VIRGINIA

# ACKNOWLEDGEMENTS

This thesis is dedicated to all who desire  
the dream.....

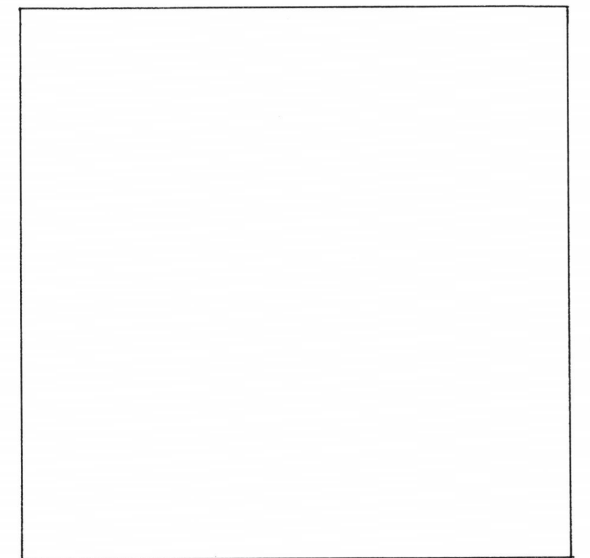

## ABSTRACT

This thesis is my commitment to this medium of social and personal expression. It is also, the development of a foundation from which my search for truth, understanding and architecture can continue through time.

The study vehicle is the design of an addition to Cowgill Hall, the College of Architecture at Virginia Polytechnic Institute and State University in Blacksburg, Virginia.

The primary determinants which contribute to the addition's form are derived from site, structure and institution.

The solution, an infill language of columns, beams and gravity walls, is ordered by interpreting these ideas into architectural elements that express an open and harmonious environment that encourages the creative spirit to flourish.

'Without the idea there can be no language, without the language there can be no expression of the idea.'

Michael J. O'Brien



## CONTENTS

TITLE PAGE	
ACKNOWLEDGEMENTS	I
ABSTRACT	II
CONTENTS	III
INTRODUCTION - THE PROPOSAL AND OBJECTIVES	1
THE PROCESS - THE SITE, EXISTING CONDITIONS	2
- SITE PLAN	3
- SITE SECTIONS AND ELEVATIONS	4
- THE STRUCTURAL SYSTEM	5
- ASSEMBLY	6
- THE FRAME	7
- THE WALL	10
- THE TOWER	13
- THE DOME	16
- THE STRUCTURE	18
- BUILDING PLANS	19
- BUILDING SECTIONS	21
CONCLUSION	24
VITA	25
SOURCES	26

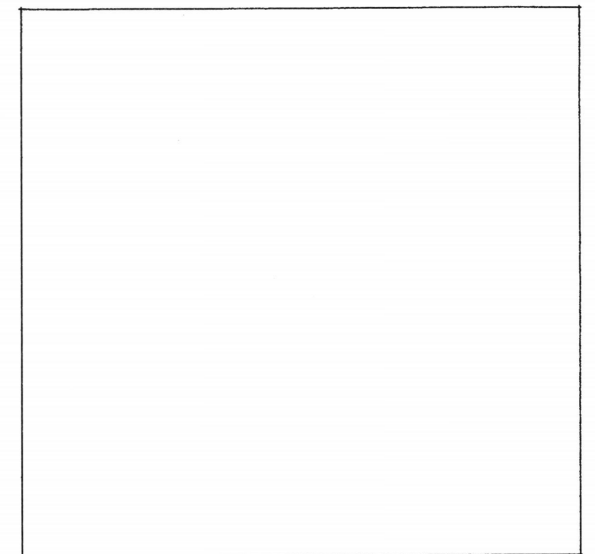

## INTRODUCTION

This thesis is my commitment to this architectural medium of social and personal expression. It is also the development of a foundation, from which my search for an individual position of truth and an understanding of the acts of order that contribute to a methodology of making form.

The vehicle for this search is an addition to the College of Architecture at Virginia Polytechnic Institute and State University in Blacksburg, Virginia. The addition contains studio, lecture, exhibition, administrative and support facilities.

The objectives of this design investigation are to create an academic environment that is in harmony with its community, that will utilize the human resource and the structure of the building as a teaching element. These objectives are explored through the relationships of the structure to the site, the elements that compose the structure and the structure as a whole.

The design process begins with the search for appropriate ideas that can bring order to the form of the composition. These ideas are interpreted into an architectural language that expresses an individual position regarding the act of making and supports a central idea of place or environment.

The primary ideas that order the addition's form are discovered in the context of the site, existing structural conditions and the specific academic institution.

Reflect for a moment on the meaning of "school" as contrasted with "a school" or institution. The Institution is the authority from which we receive the special requirements for a school. A school, or a specific design is what the institution expects from us. But "school"-the spirit school, the essence of the Existence Will-is what the architect should convey through the medium of his design.

Louis I. Kahn

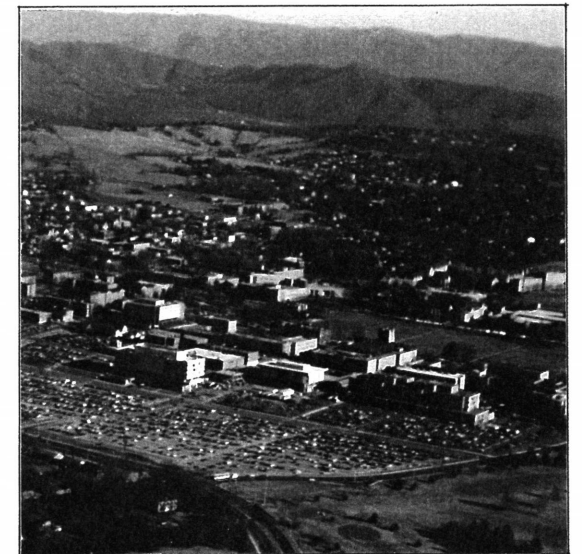

## THE SITE

The site is located on a grassy knoll behind Cowgill Hall on the outer realm of the academic community.

The site is bounded by the infill structures of Cowgill, Derring and Whittemore Hall, the edge of Perry Street and the commuter parking facilities.

Conditions that begin to order and zone the site, are the quadrant language of the academic community, solar orientation, axis and the future entrance to the University from Prices Fork Road.

The quadrant language of the campus plan makes a network of outdoor spaces that are defined by perimeter structures and linked by pedestrian and/or vehicular traffic patterns. (See Diagram "A".)

The orientation of the site receives full solar exposure to the southeast and prevailing winds and storms from the northwest. (See Diagram "B".)

The site has a axial condition established by the alignment of Burruss Hall, Cowgill Hall and the future University entrance from Prices Fork Road, which bisects the commuter parking facilities. (See Diagram "C".)

A. CAMPUS PLAN



B. SOLAR ORIENTATION

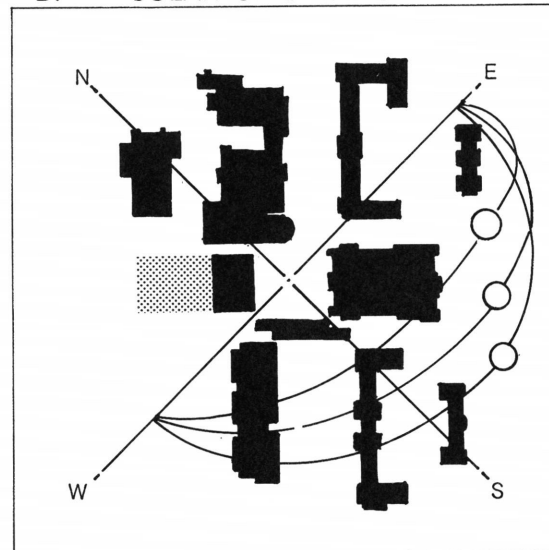

C. AXIS

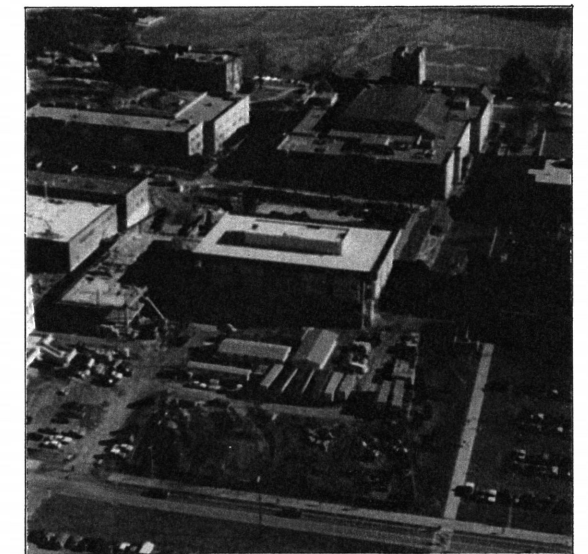
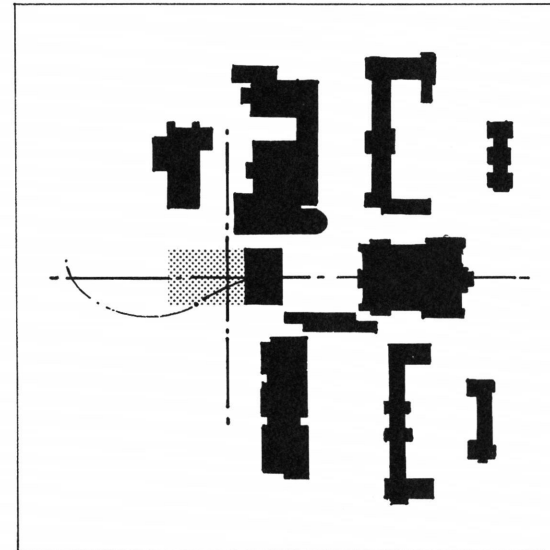

## THE SITE PLAN

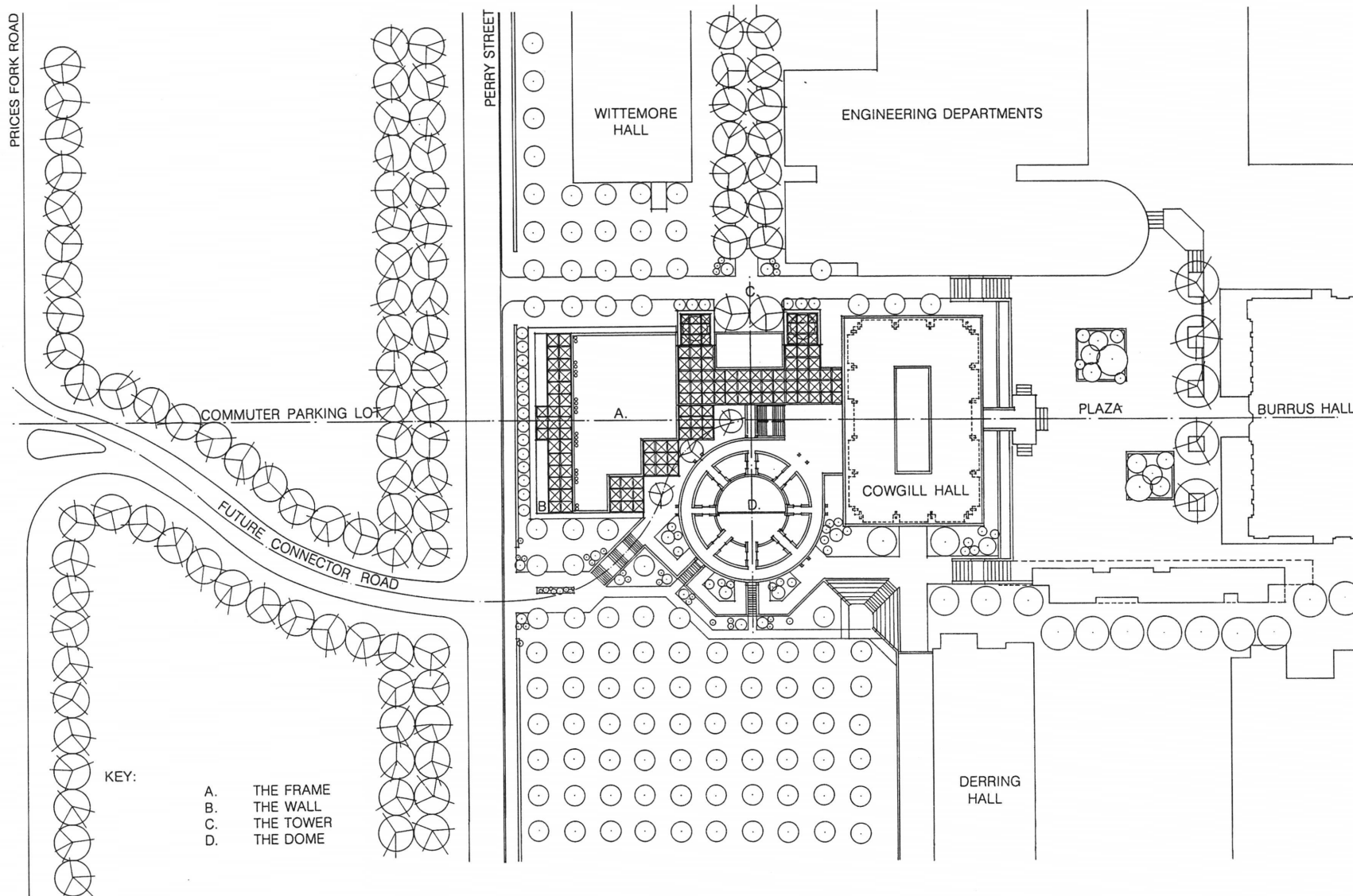

The site plan is a collective response and respects to the individual ideas of structure, orientation and axis that bring order to the composition.

The primary architectural elements that make up the structural language of the site are the frame, the wall, the towers and the dome. These elements are located on the perimeter of the site to create an outdoor space that is in concert with the spacial structure or quadrant pattern of the academic community.

The orientation of the structure protects the inner plaza from prevailing winds from the northwest and provides even natural light to the public gathering and circulation spaces from the southeast.

The primary and secondary axial conditions formally link the pedestrian and vehicular traffic patterns to the primary gathering space that orders the site.

The solution, a human conduit of sorts, utilizes the edge of the site as a threshold to the University and the School of Architecture. The solution also, and most importantly, fosters the act of gathering, observation and dialogue between the institution's strongest resource, it's people.

The conviction that a building cannot be placed on a site, but that a building grows from its site, is another principle in which I believe. I see architecture not as the building alone, but the building in relation to its surroundings, whether nature or man-made surroundings. I believe very strongly that the single building must be carefully related to the whole in the outdoor space it creates.

Eero Saarinen

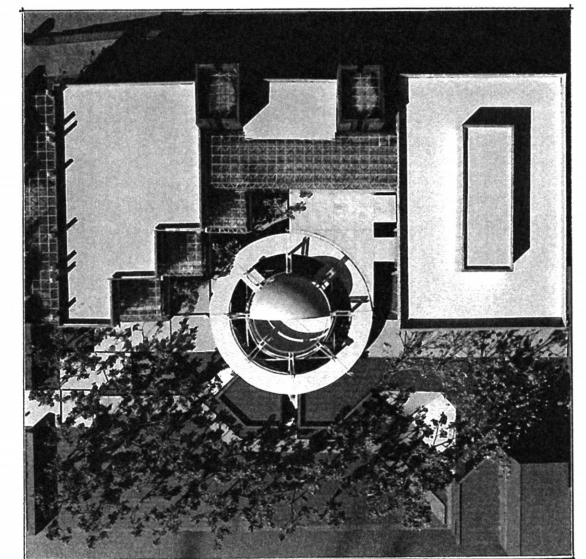

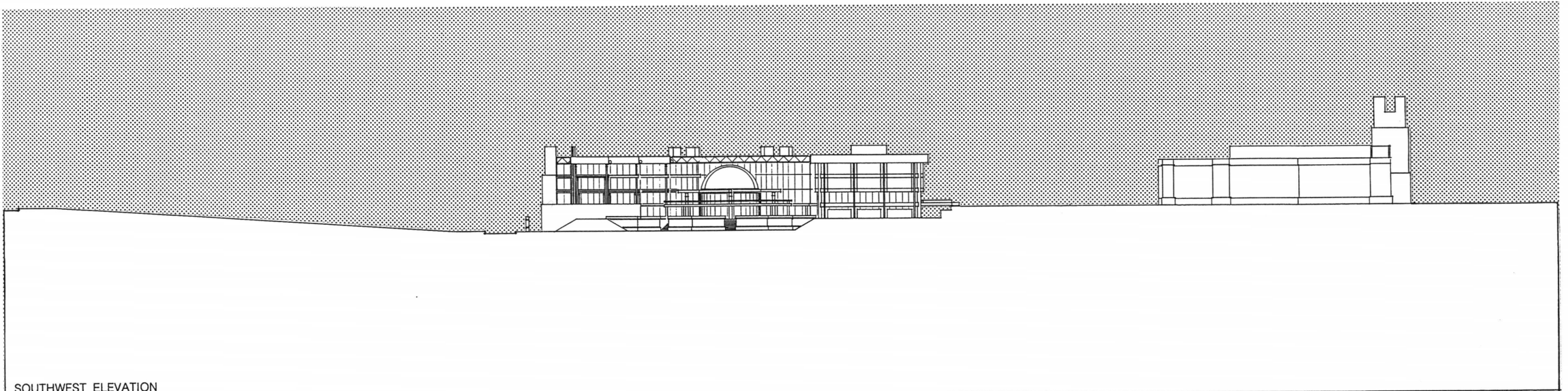

SOUTHWEST ELEVATION



NORTHWEST ELEVATION

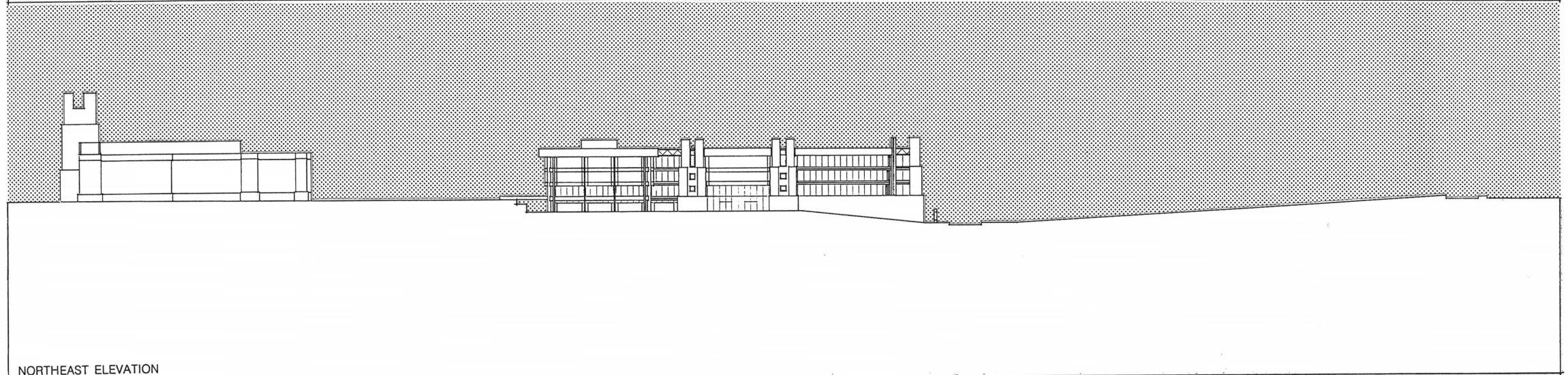

NORTHEAST ELEVATION



## THE STRUCTURAL SYSTEM

The rules that contribute to the order of the structure are derived from ideas that incorporate the infill and gravity wall languages of the University into an assembly system that generates great volumes of uninterrupted space.

The elements that compose the structural system are the frame, the wall, the towers and the dome. (See Model Diagrams "A" through "D" on page 5.) They are constructed of a concrete post and beam frame, stone gravity walls, and concrete double tee beam members. The frame and the stone walls are a synthesis of the two languages that make up the fabric of the University. The elements of the frame are laterally stabilized by the wall and tower elements. The double tee members, through the technology of the precast concrete system, accommodates the spanning requirements necessary to create free space for the studio areas.

The structure is a considerate attempt to create harmony between the languages of the community and existing conditions that influence the overall environment. However, it is the honesty and simplicity of the structural system that creates the flexibility to utilize the structure as a teaching resource that encourages positive observation, interaction and dialogue between it's students and facility.

A. THE FRAME

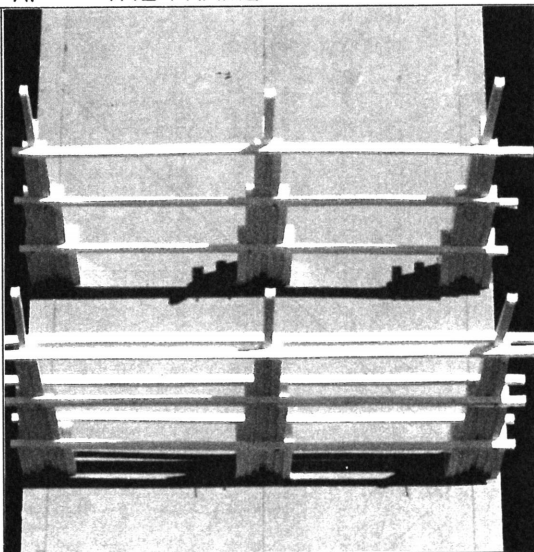

B. THE WALL

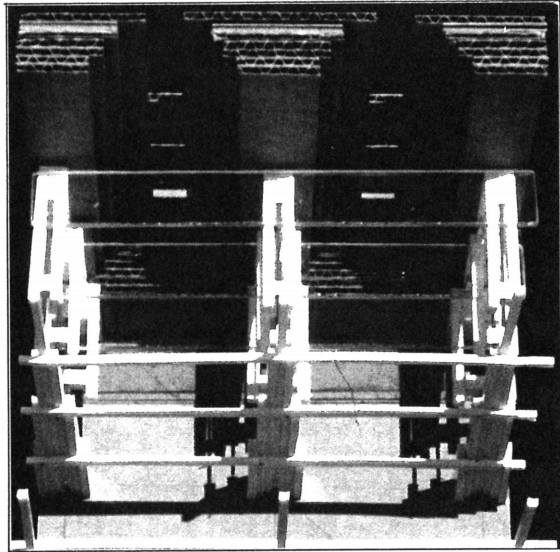

C. THE TOWER

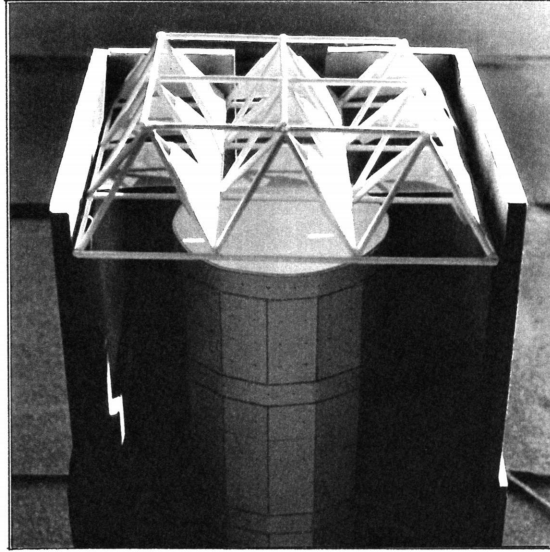

D. THE DOME

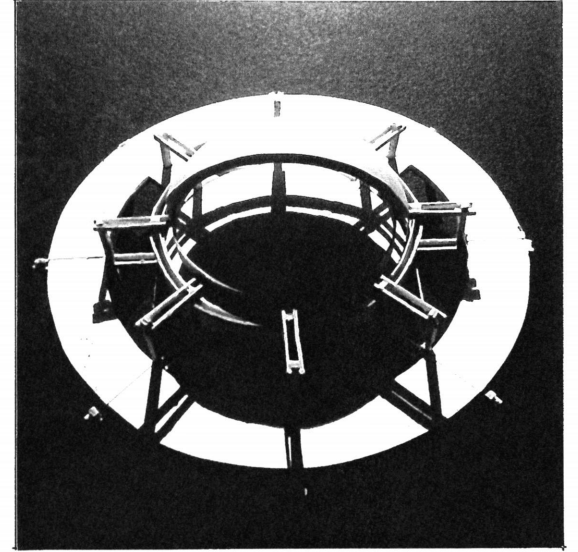

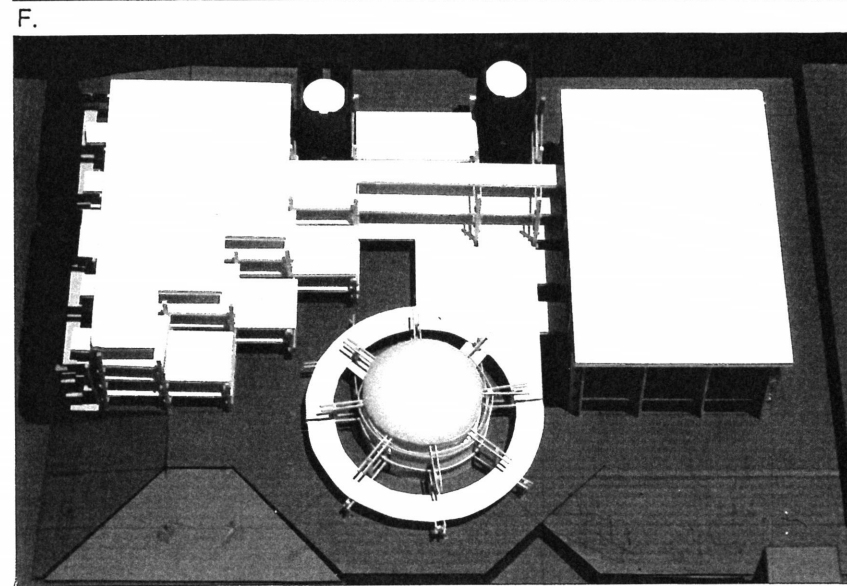
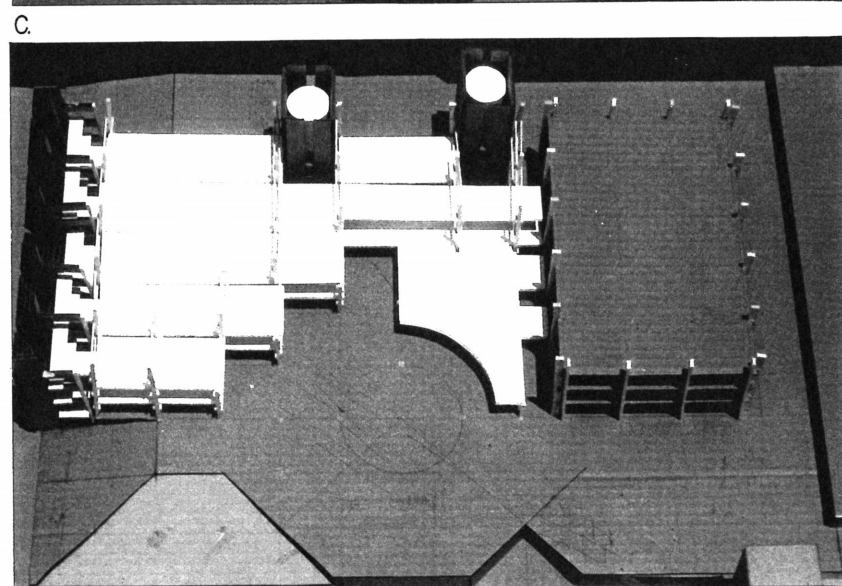
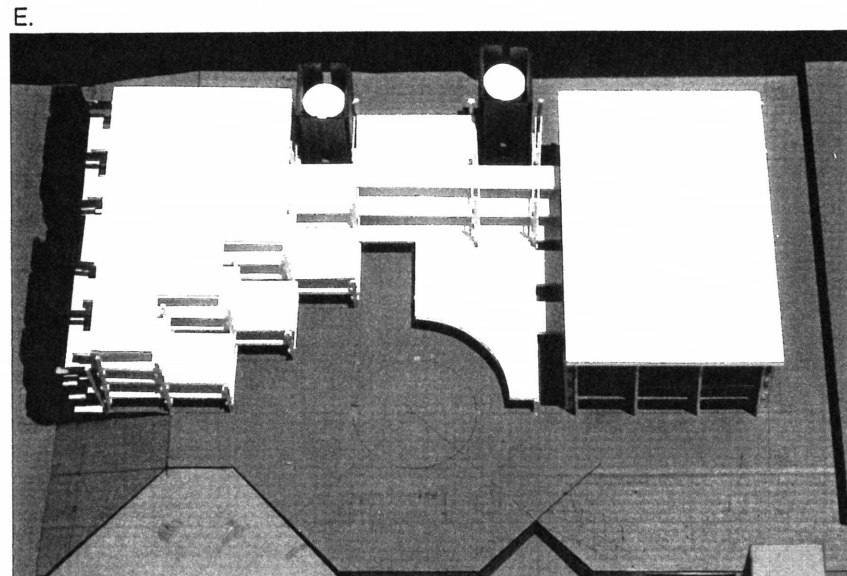
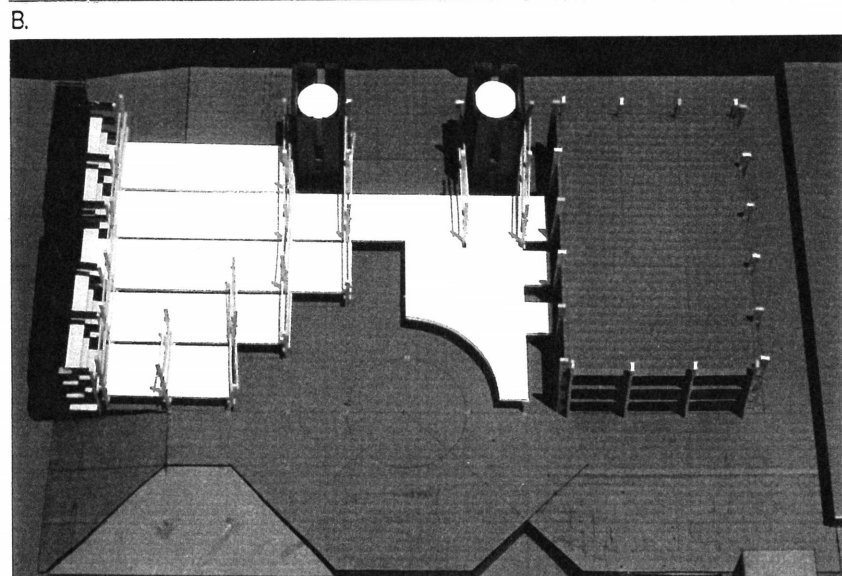
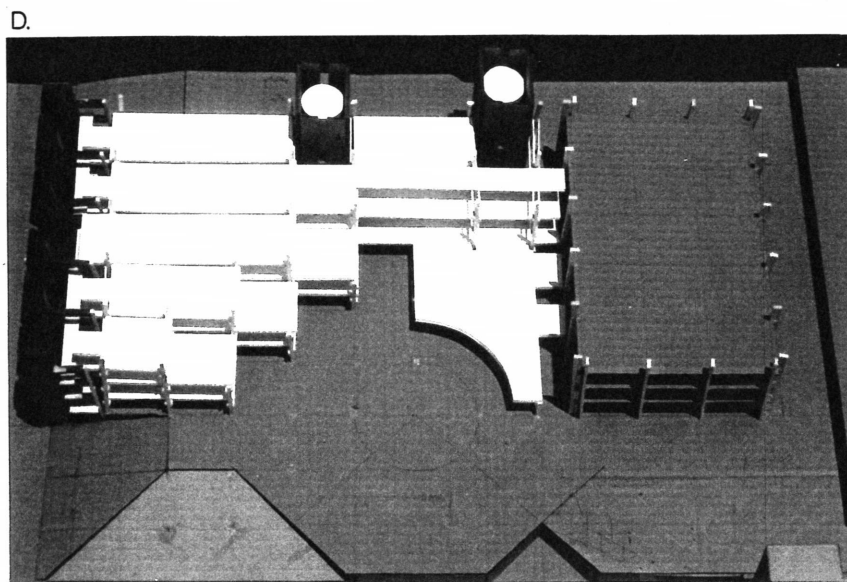
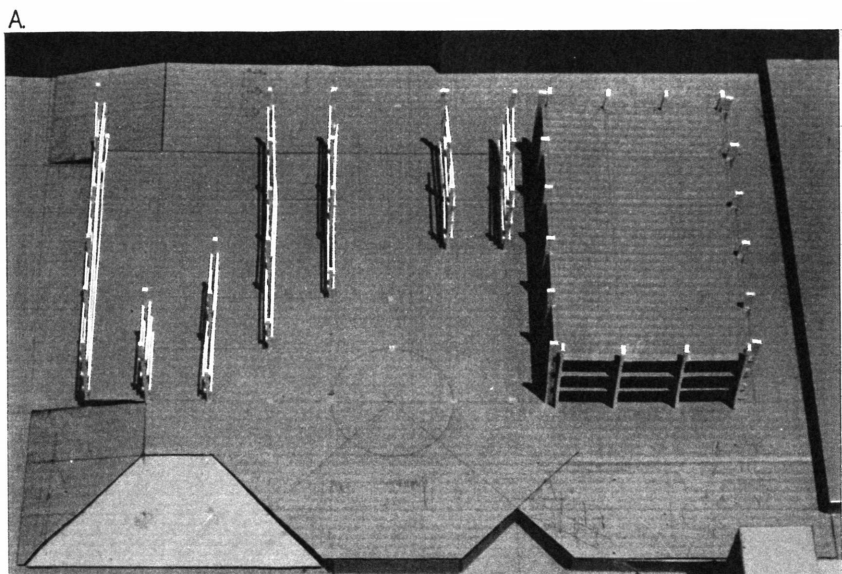

The elements of the structure are assembled vertically in an additive manner. The process begins with the construction of the first level of the poured-in-place concrete columns, the stone wall along Perry Street and the stone towers adjacent to the Engineering Departments. As each level of these elements is completed, the precast concrete beams are placed onto the columns and lateral members thereby creating a rigid frame. As each level of the frame is completed, the double tee beam flooring members are placed onto the precast beams completing the structural diaphragm. Once each layer is completed, the system continues to the next level. (See Model Diagrams "A" through "F" on page 6.)

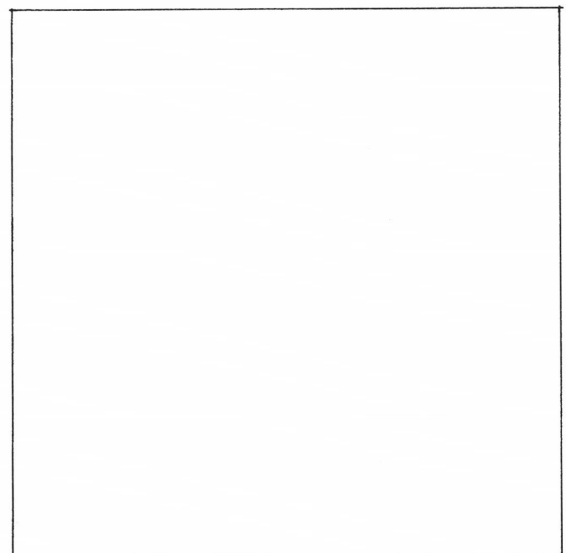

## THE FRAME

The frame of the structure is further defined by a desire to express the order of the individual elements and the natural distribution of the structural loads. It is composed of poured-in-place concrete columns, precast concrete beams, and precast double tee beams which act as flooring members. The roof members are also double tee beams, with the exception of the primary circulation spaces, which receive a space frame system that provides natural light and zoning to the circulation areas of the structure.

The structural elements are ordered in a manner similar to the hierarchy of Cowgill Hall. That being, the expression of the column as the primary element, the beam as the secondary element and the tee beam as the final element. (See Sketches "A" & "B" on page 9.)

The columns have an additive layering quality that expresses the different levels and loads that each column carries to grade. (See Plan and Elevation on page 8.)

The precast beams act as transitional links between the floor and column members. They express the direction of roof and floor loads to the columns.

The floor and roof double tee members were conceived as a considerate attempt to derive a language from the concrete coffer system of Cowgill Hall. The order of these members accommodates the spanning of the studio areas and creates an opportunity to cantilever out and meet the existing structure of Cowgill Hall. (See Model Photograph on page 9.)

If everything goes well and everything is really performing within one idea and the structural system is the right one, with the right materials and methods and so on, it becomes the thing which locks everything together. When that happens, it is a marvelous feeling. The structural system then seems to reinforce an inevitable solution to the site problem, and, at the same time, an inevitable solution to the functional problems and, at the same time, an inevitable solution to the spirit. All these things get locked together into one thing.

Eero Saarinen

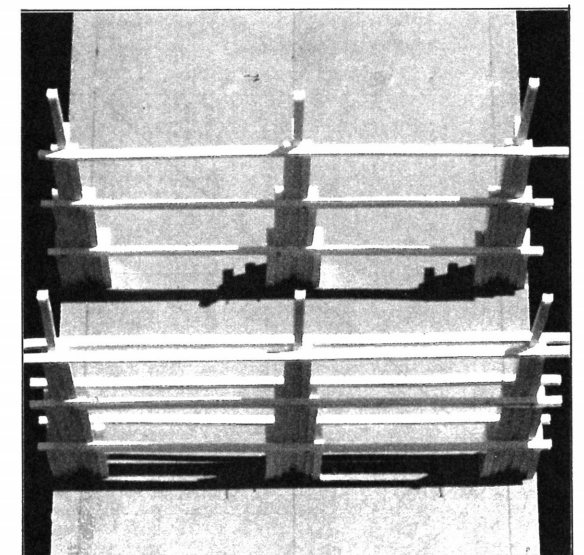

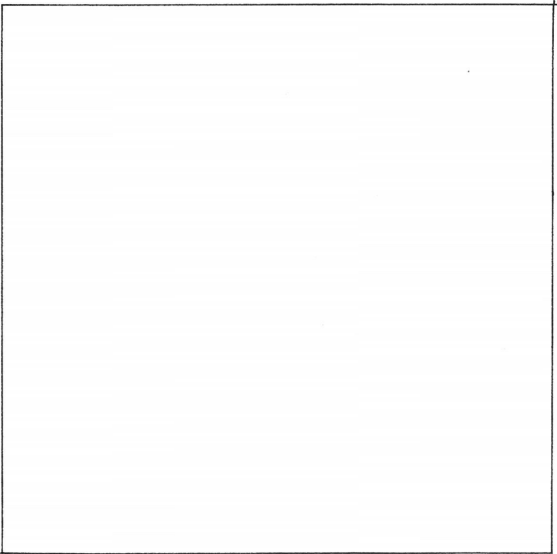
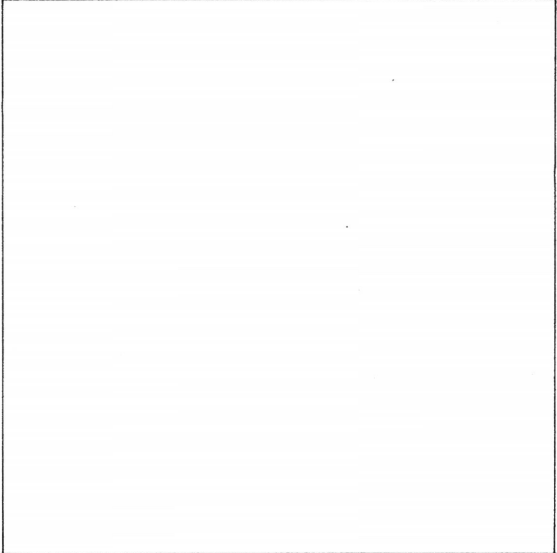
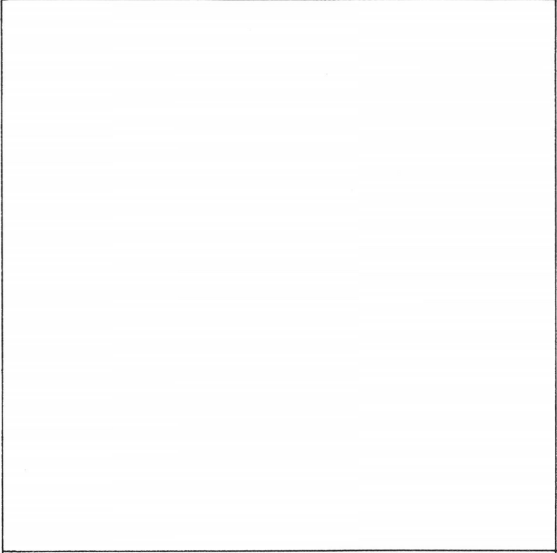
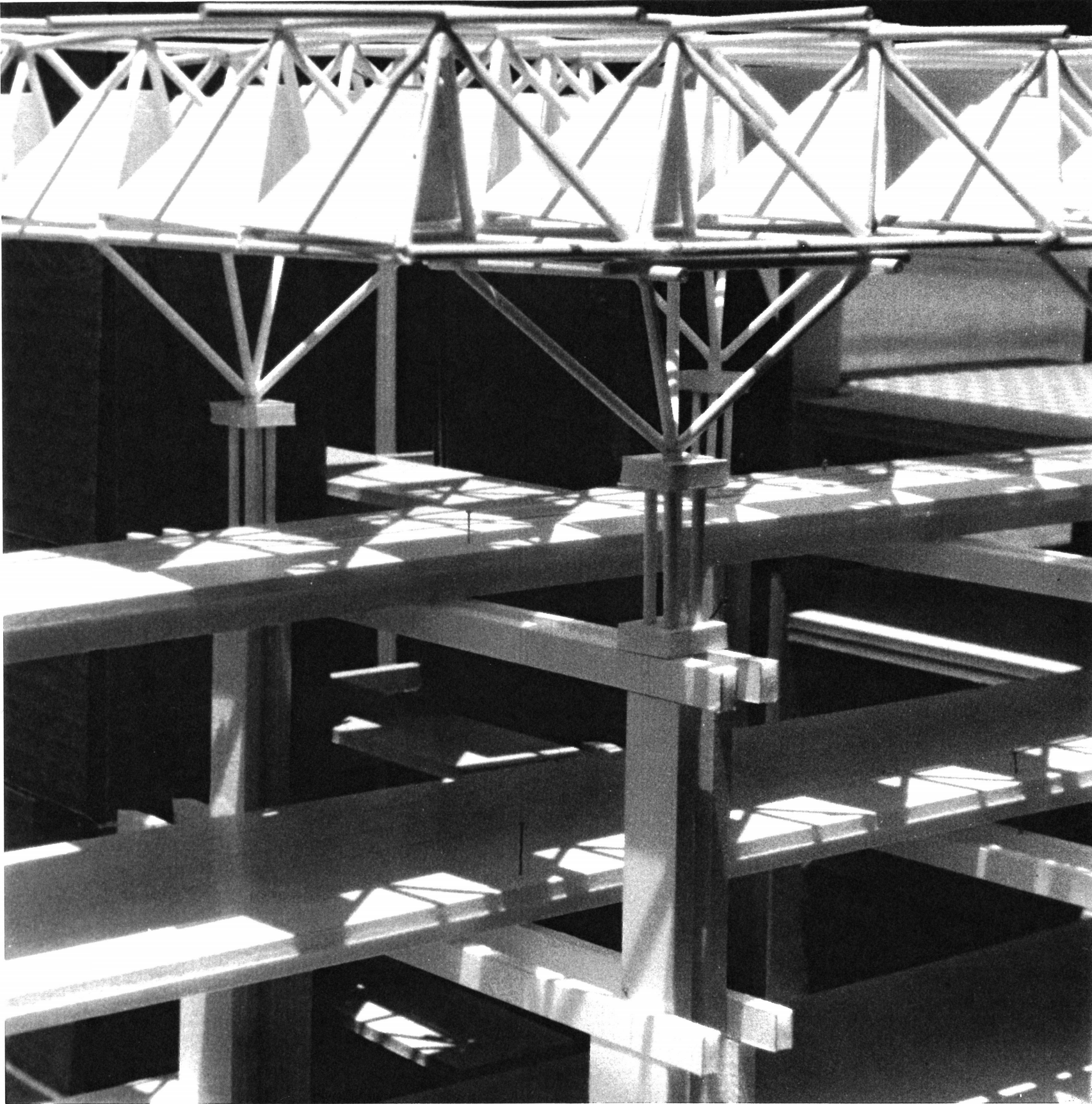

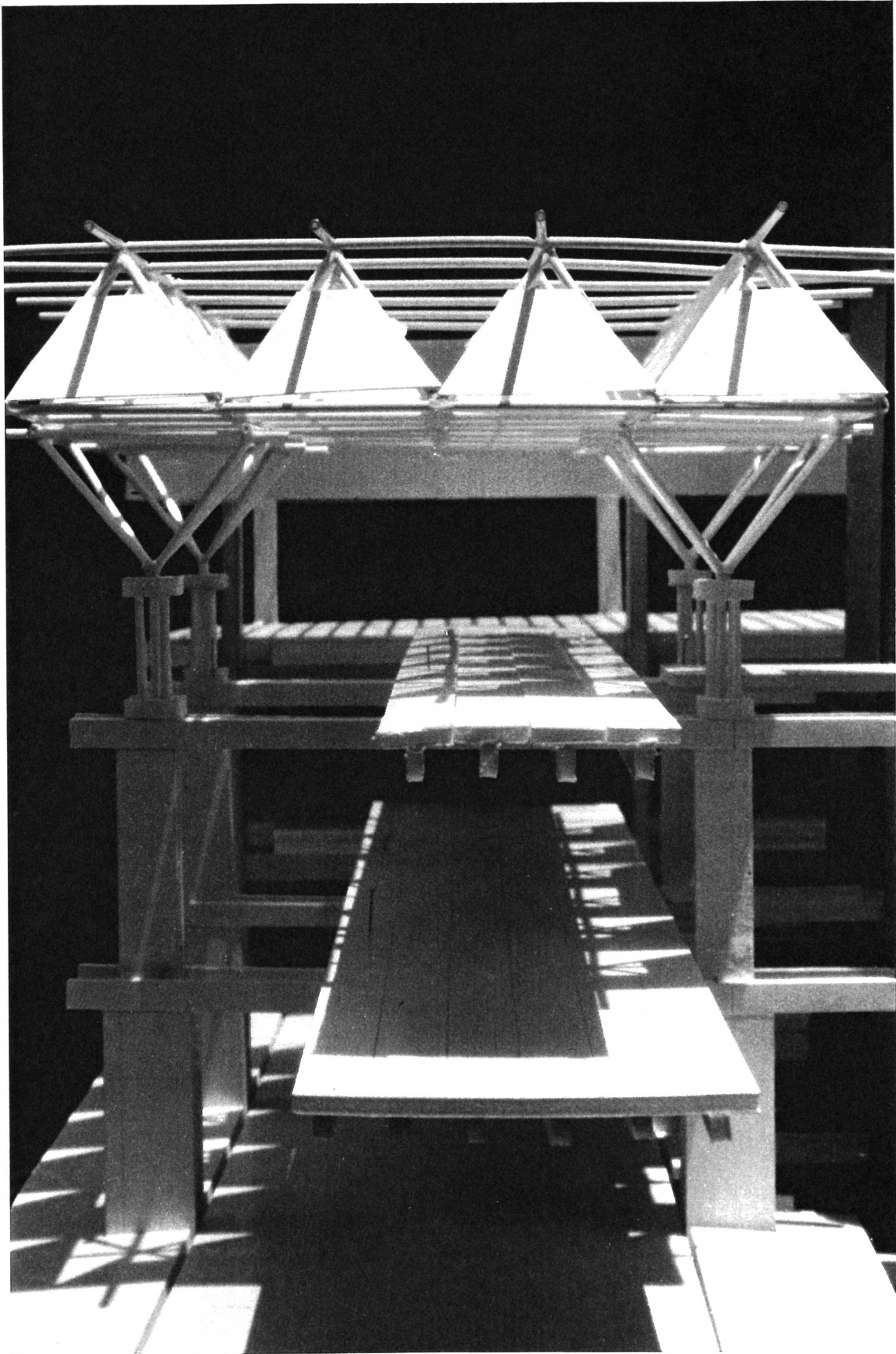

ELEVATION

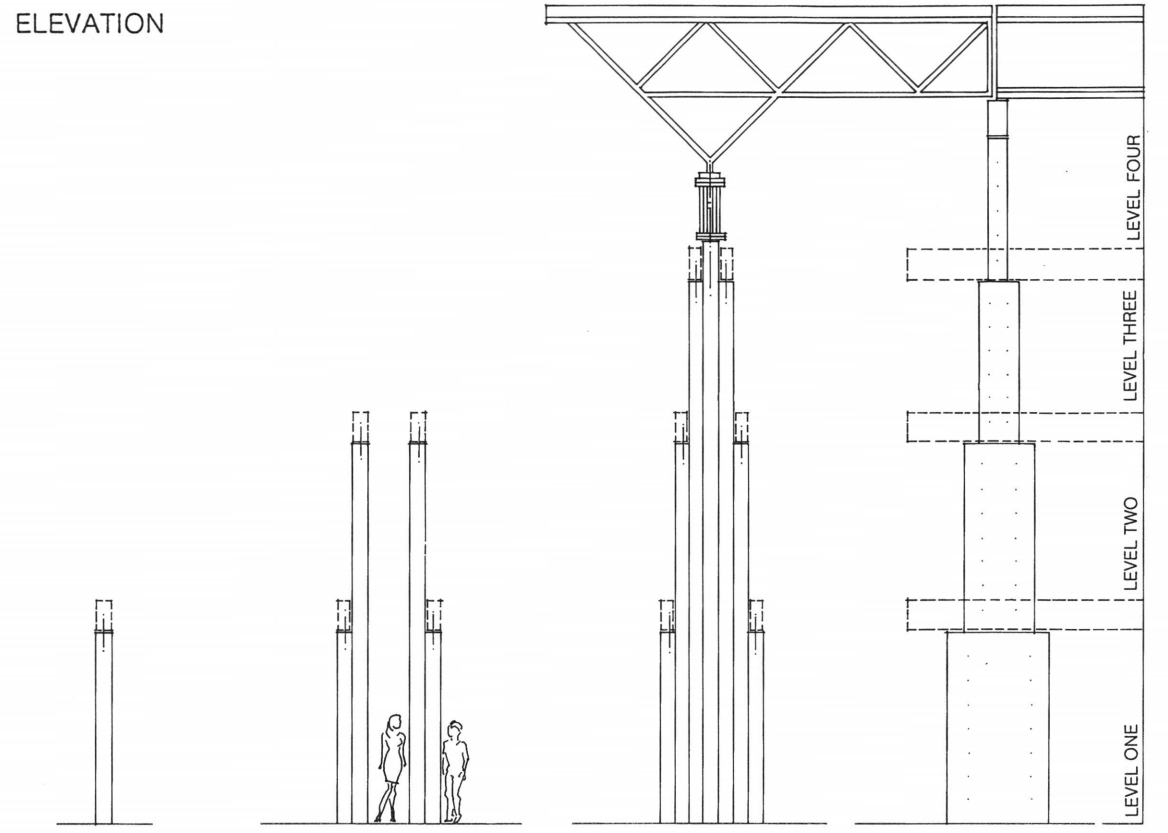

PLAN

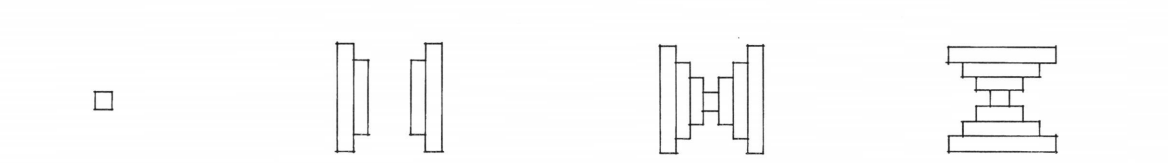

"A" COWGILL HALL

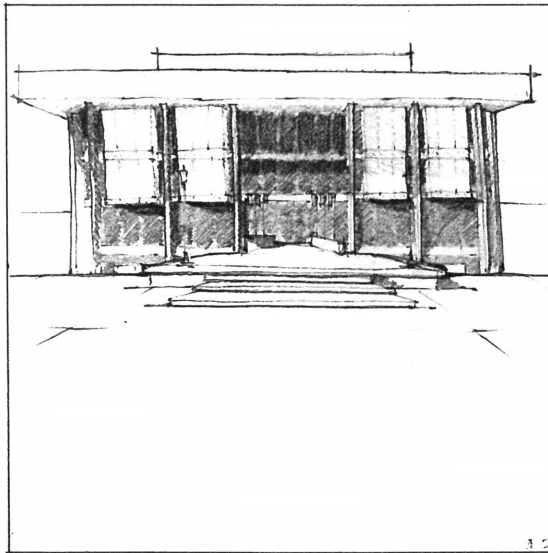

"B" COWGILL HALL

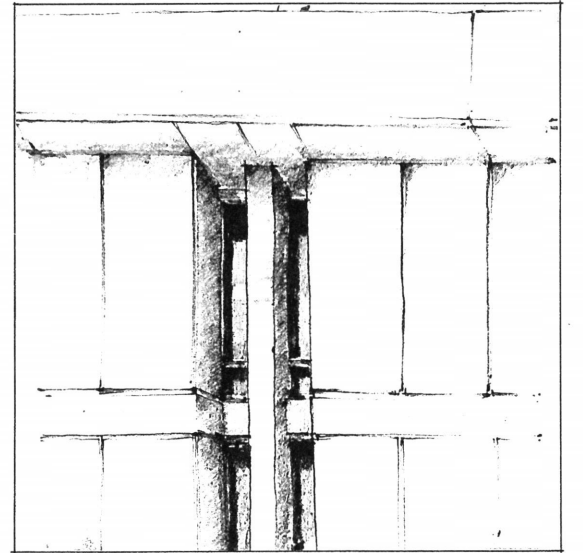

## THE WALL

The form of the wall is further defined as the element responds to the nature of the building material, it's relationship to the frame and program requirements.

The element, a cut stone gravity wall, derives it's order from the stacking of the material in an additive bonding manner. (See Sketches "A" and "B" on page 12.) It is the order of the material, or it's rules of making, that allow the wall to respond to the loads of the material, it's relationship to the frame, and accommodates circulation, office and mechanical areas by subtracting material from the mass to create place. (See Model Photograph on page 11.)

The additive language of the wall expresses the natural order of the material, the acts of making and conditions that contributed to the overall form. The stone language and mass of the wall creates a protective layer against the edge of Perry Street that shelter's the inner environment and encourages the act of gathering. The element also acts as an entrance signal from Prices Fork Road, by drawing the inner stone language that is associated with this institution, to the outer layer of the campus plan.

The wall of the street literally became the building. Walls in my mind are created by the thoughtful stacking of things.

The walls generosity and responsibility also extends to the street as it becomes a joint between the private and public worlds. The wall of the building itself is a component, a brick, in the wall of the street. Lastly, the wall also is the structure which allows the building to exist.

Michael Benedikt

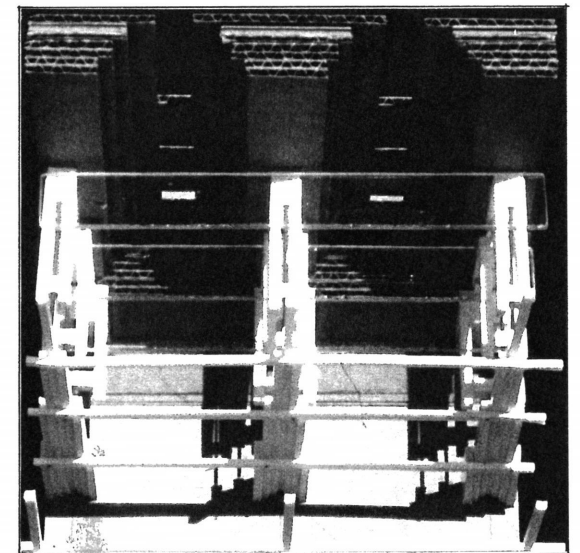

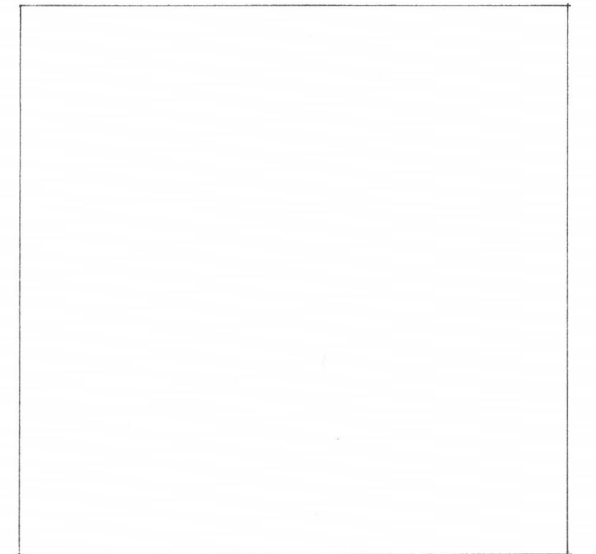
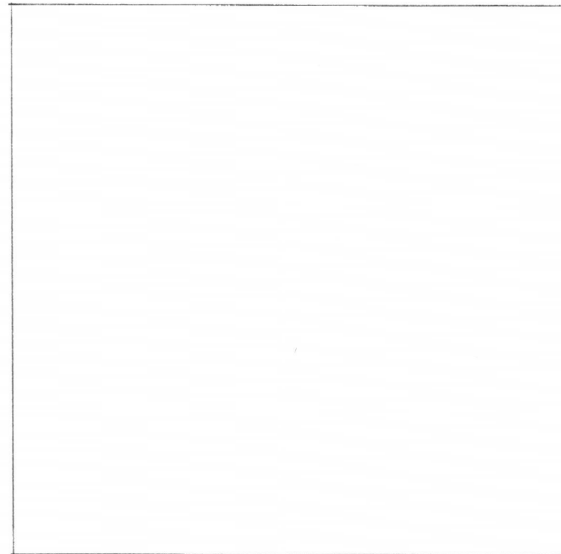
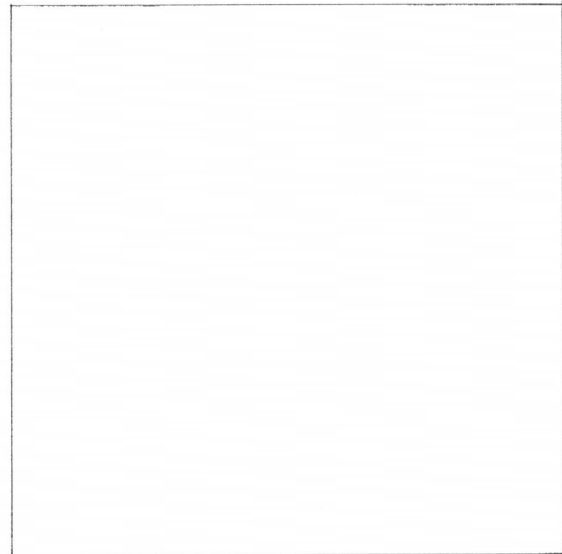
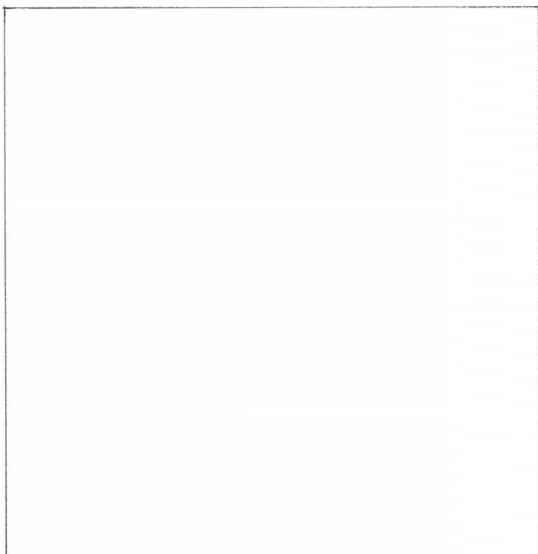
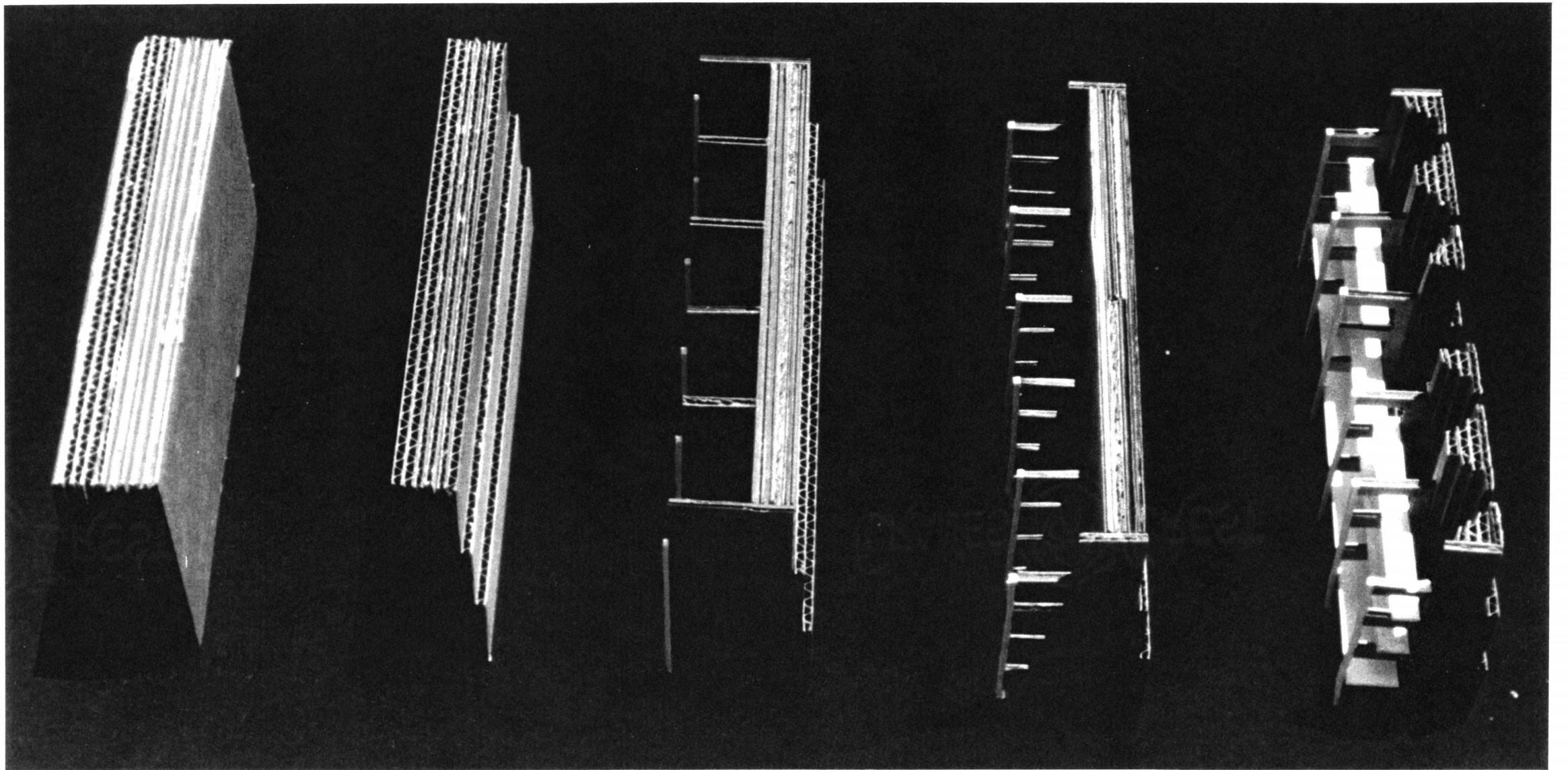



PLAN

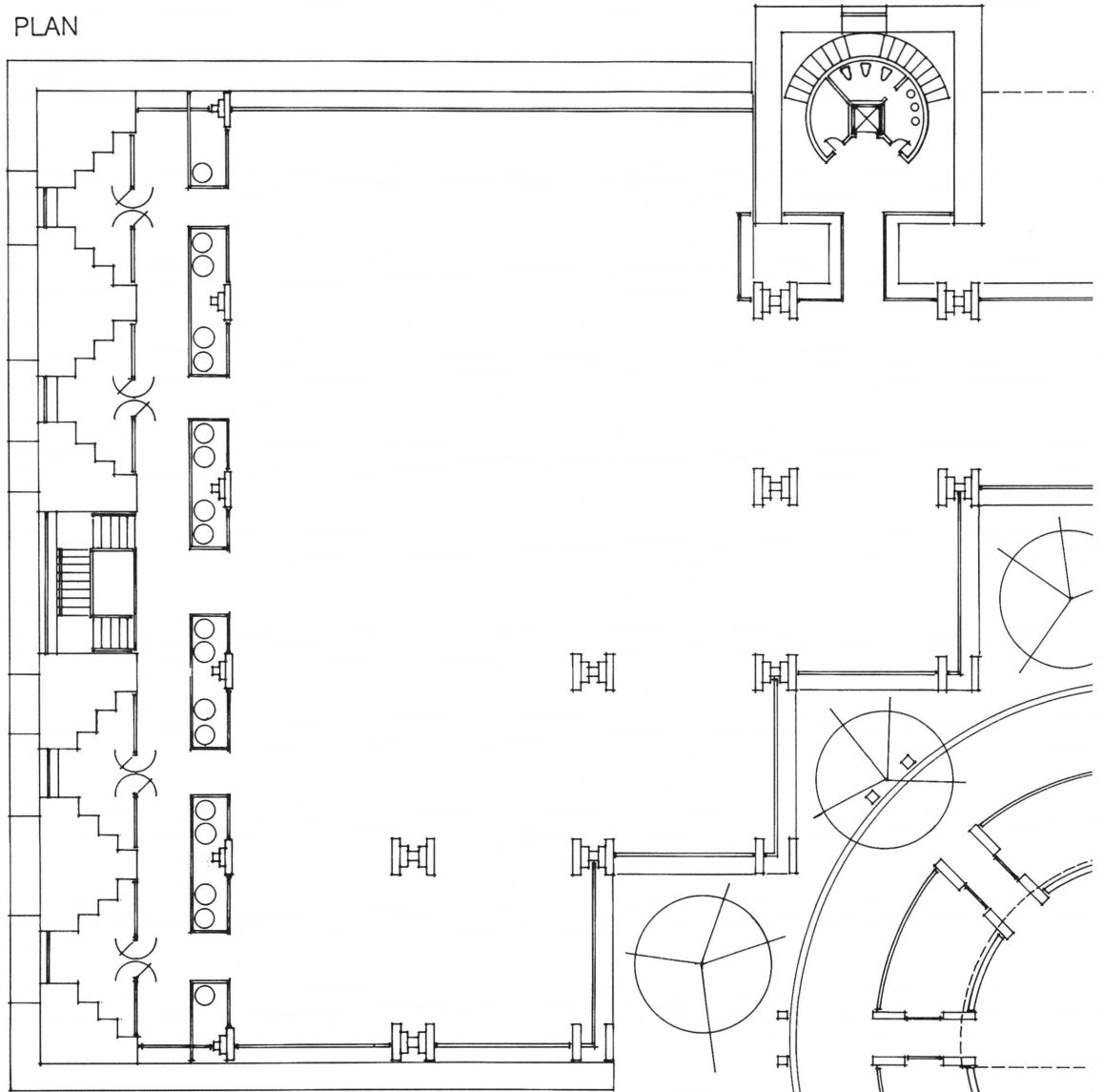

"A" BATH HOUSE - L. KAHN

"B" EXETER LIBRARY - L. KAHN

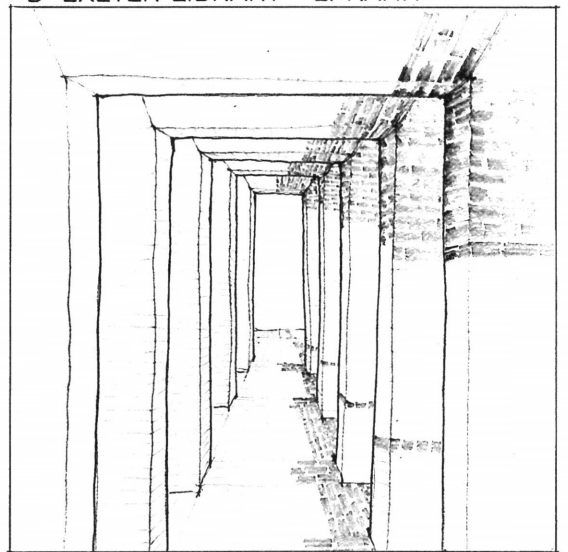
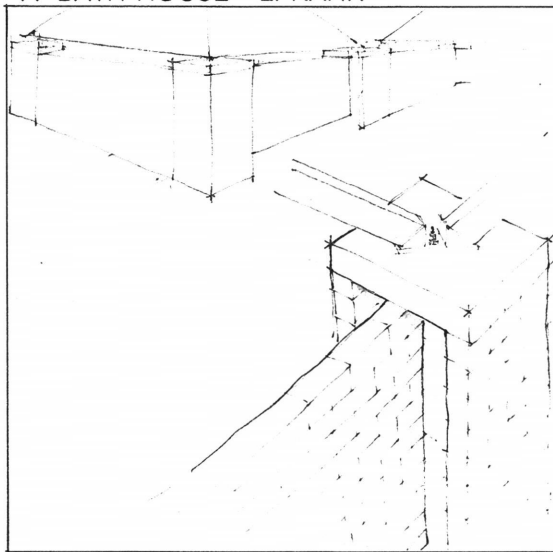



## THE TOWERS

The walls of the towers, similar to the wall along Perry Street, derives their form from the nature of the building material, it's relationship to the structural frame and program requirements.

However, instead of using subtractive variables to create places within the stone mass, a poured in place concrete core is provided to accommodate restrooms, dark rooms and circulation requirements. (See Model Photograph on page 15.)

The circular concrete mass stems from a desire to create efficient circulation patterns, foster the act of movement and visually play within the geometric order of the tower walls.

In addition to the protective quality that is created by the stone language of the tower walls, the inner concrete core reveals, through the finish, form ties, remnants of the wood form work, the plasticity of the concrete material and the individual acts of the making which contributed to the form of the whole. (See Sketches "A" and "B" on page 15.)

The pairing of the tower elements creates a gateway to and from the engineering departments. This gesture, encourages dialogue, awareness of the related mediums, their roles and responsibilities to each other, society and the environment. (See Plan on page 15.)

It is important that you honor the material you use.

You must honor and glorify the brick instead of short-changing it and giving it an inferior job to do in which it loses its character.

You can have the same conversation with concrete, with paper or papier-mache, or with plastic, or marble, or any material. The beauty of what you create comes if you honor the material for what it really is.

Louis I. Kahn

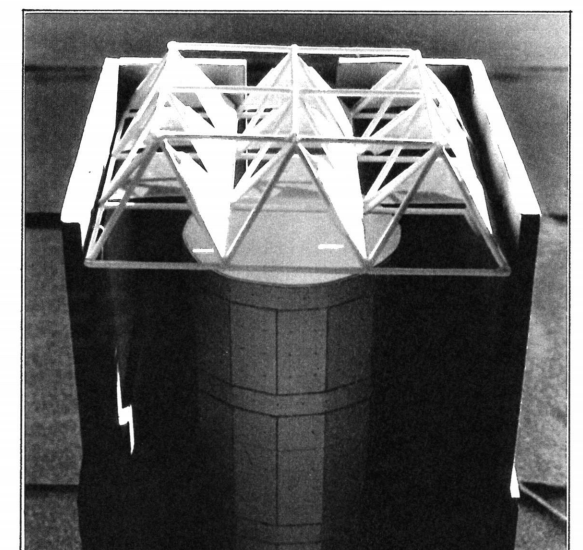

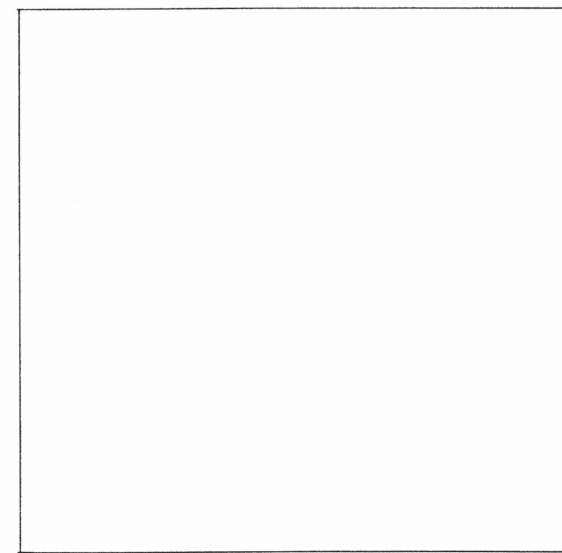
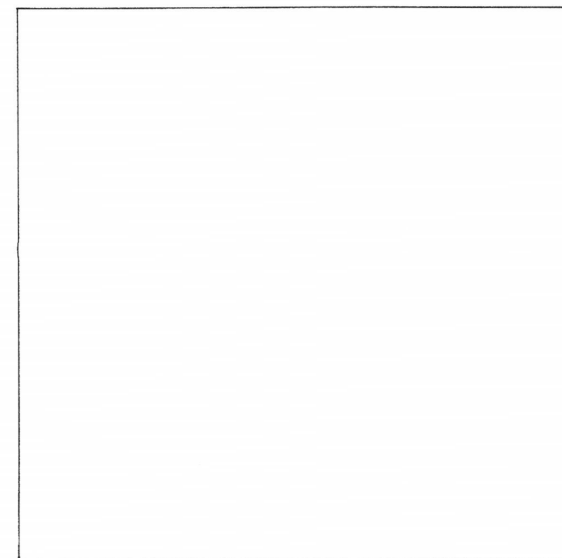
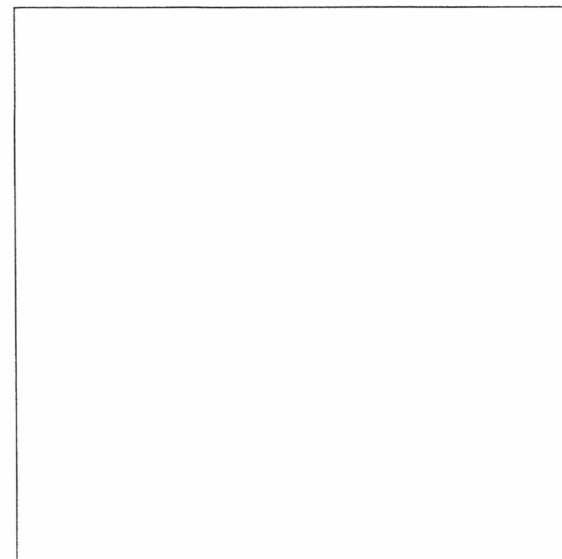
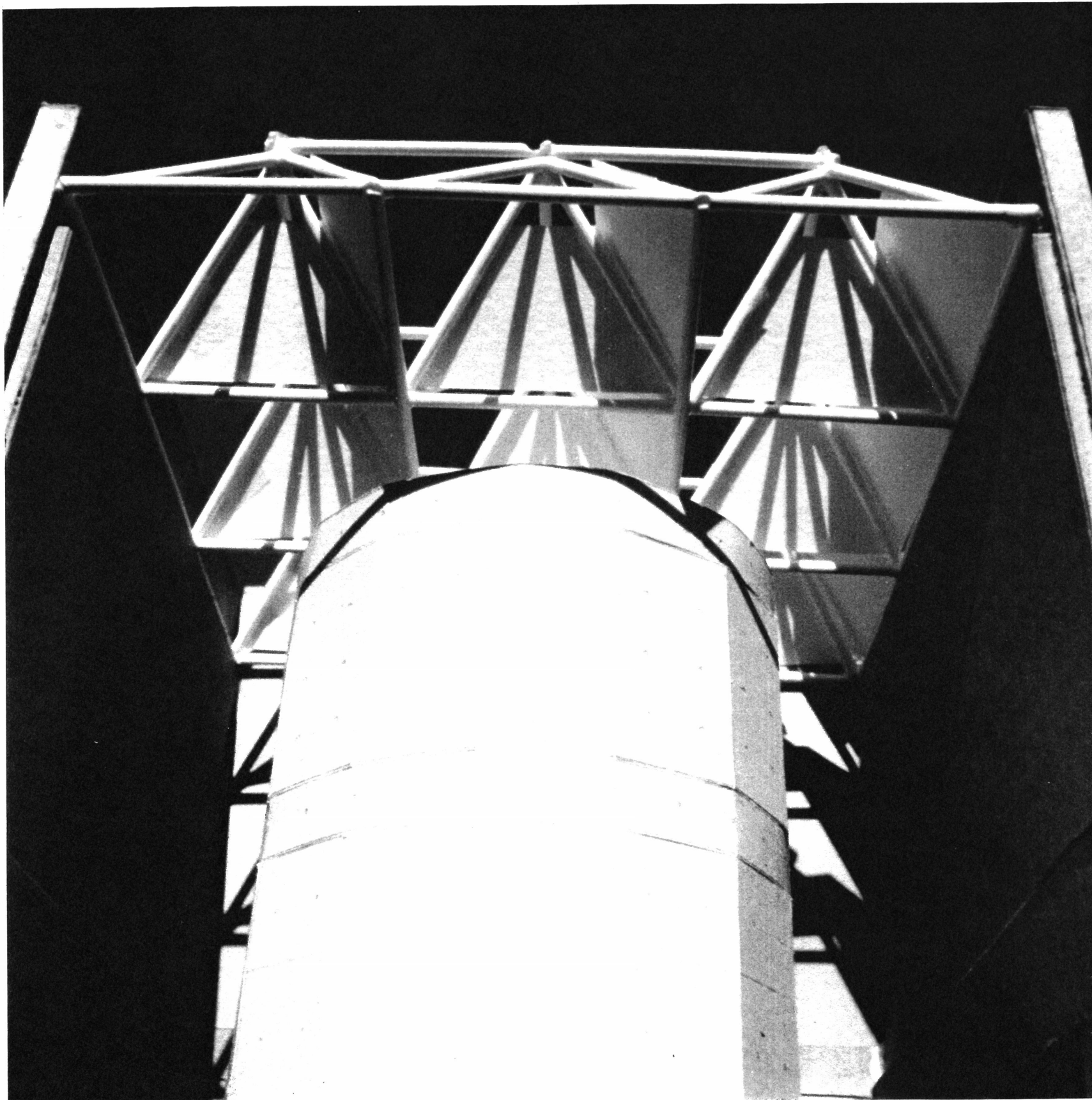

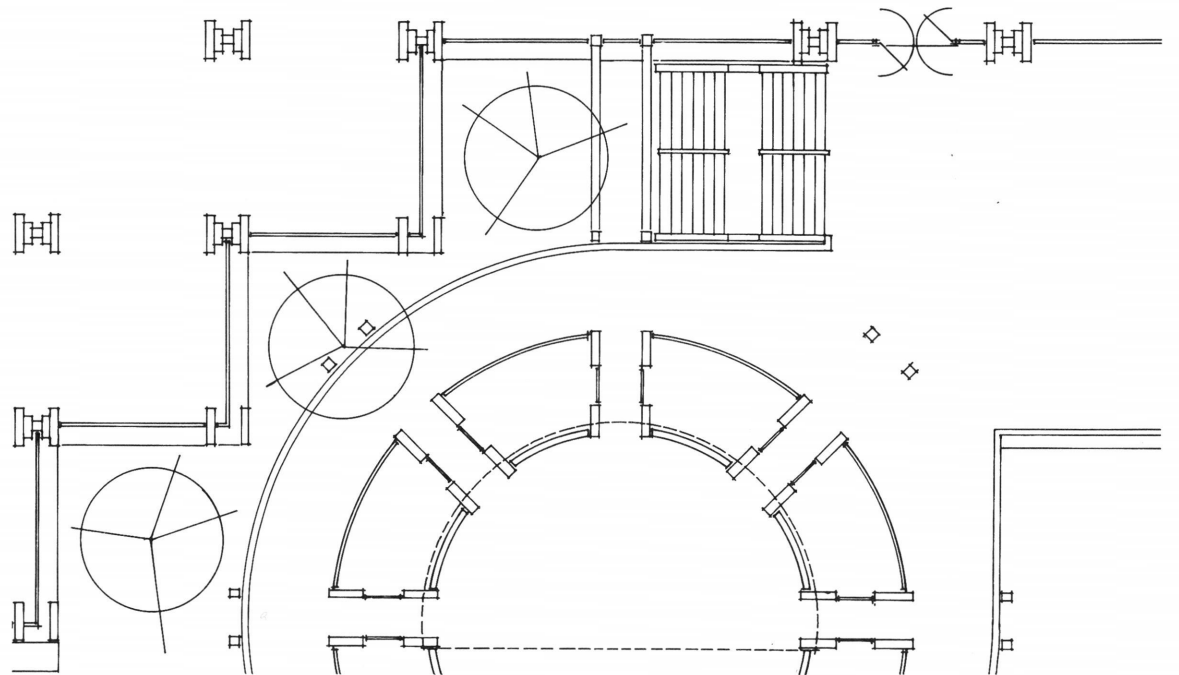
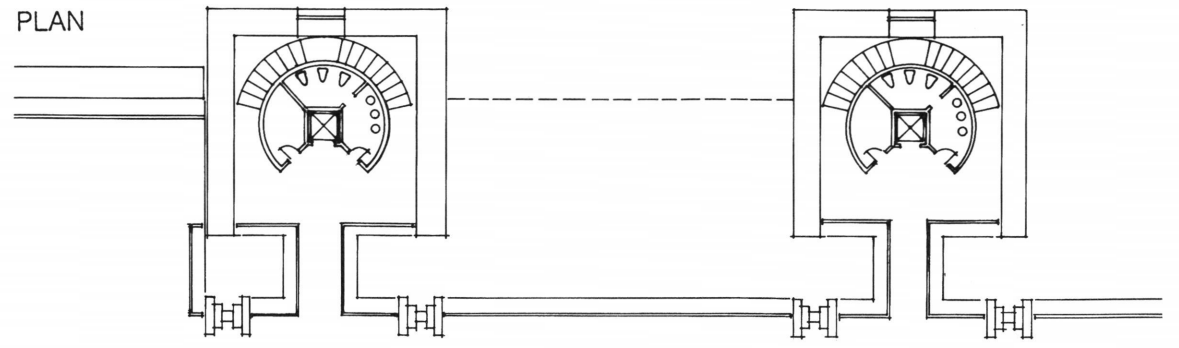
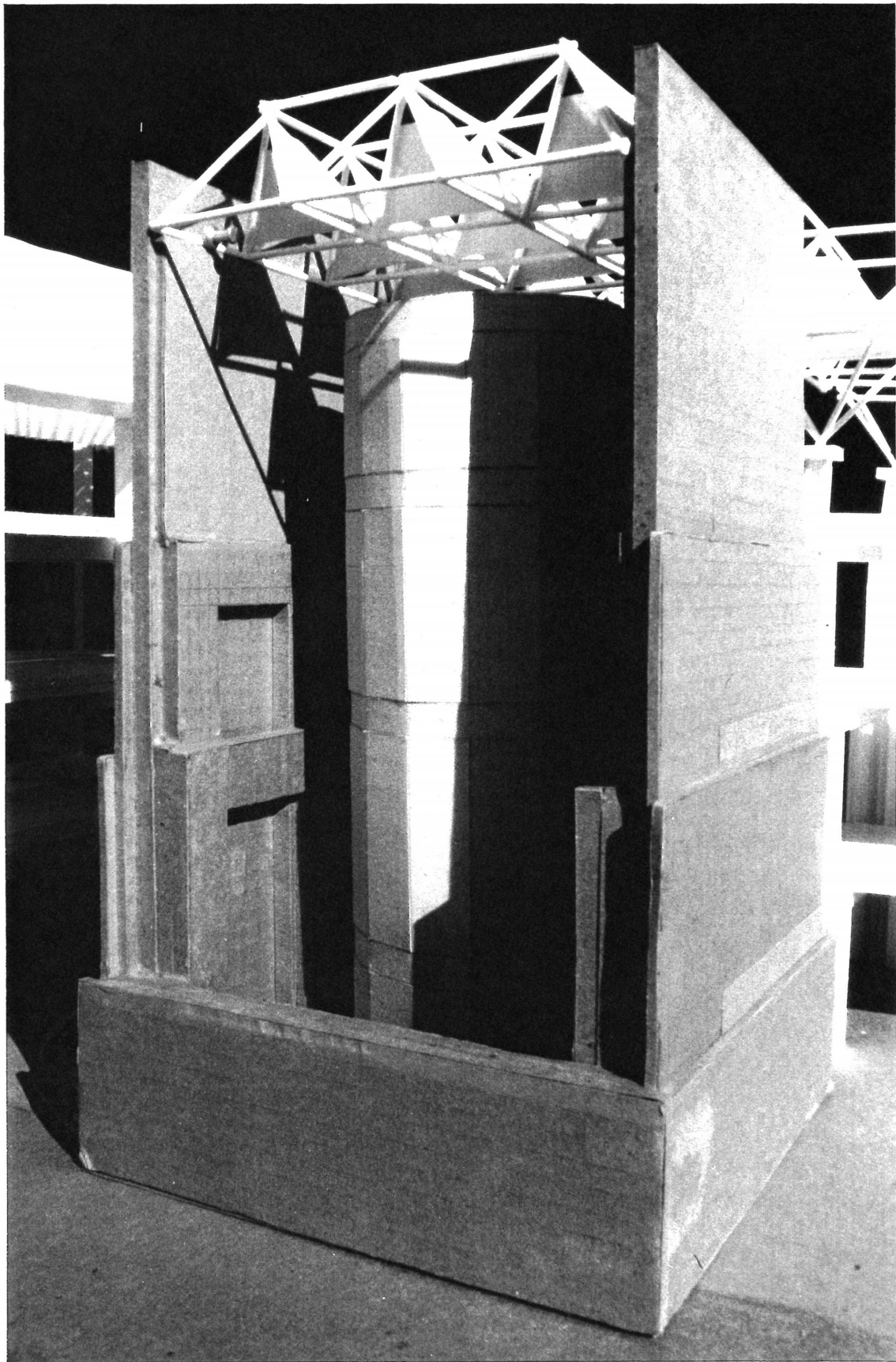

"A" YALE CENTER FOR BR. ART - L. KAHN

"B" EXETER LIBRARY - L. KAHN

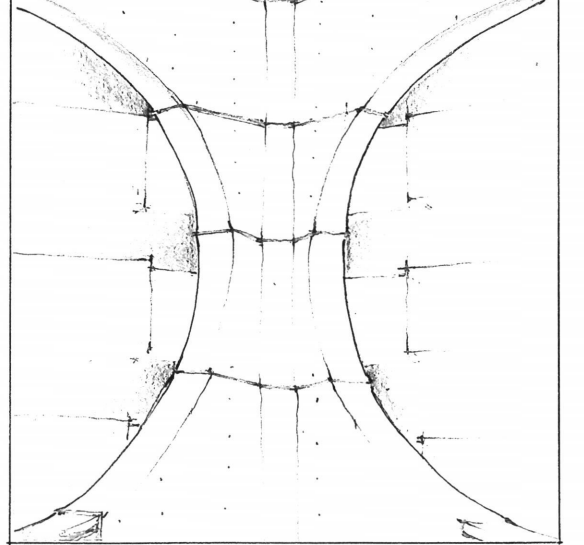
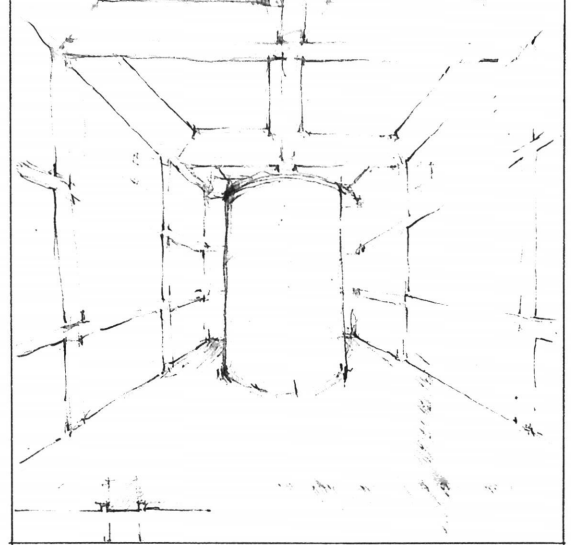

## THE DOME

The form of the dome structure is derived from a desire to create a public space which will foster circulation, promote gathering and visually order the other elements in the composition.

The structure, and extension of the rules of making that order the column frame language, is ordered in a circular manner. (See Model Photograph on page 17.) The circular form promotes efficient pedestrian circulation through the complex to and from the academic community and the commuter parking facilities.

The area defined by the frame of the structure is enclosed by a poured-in-place concrete dome. The dome is cut in section to communicate the inner structure of the form.

The transparent nature of the elements encourages observation, the act of gathering and an exchange in dialogue between the students and the visitors to the university. The form also visually orchestrates the other elements within the structural system of the Cowgill Complex.

It is a quality that is perhaps the least understood of all. It is a quality that cannot be taught. This quality is the philosophy and thinking behind architecture; it is the expression of one man's unique combination of faith and honesty and devotion and beliefs in architecture, in short, his moral integrity.

Eero Saarinen

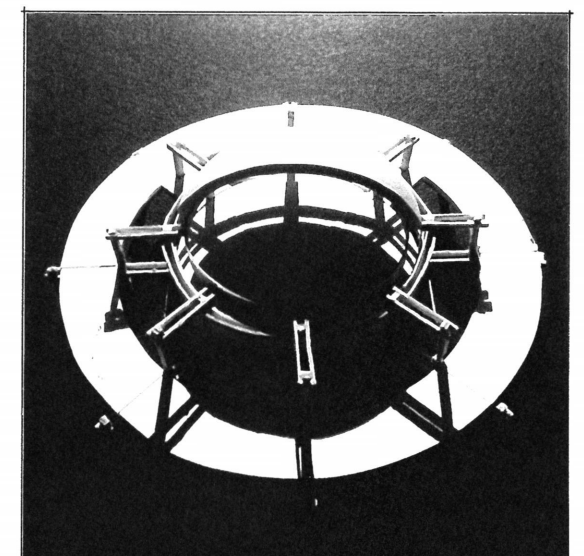

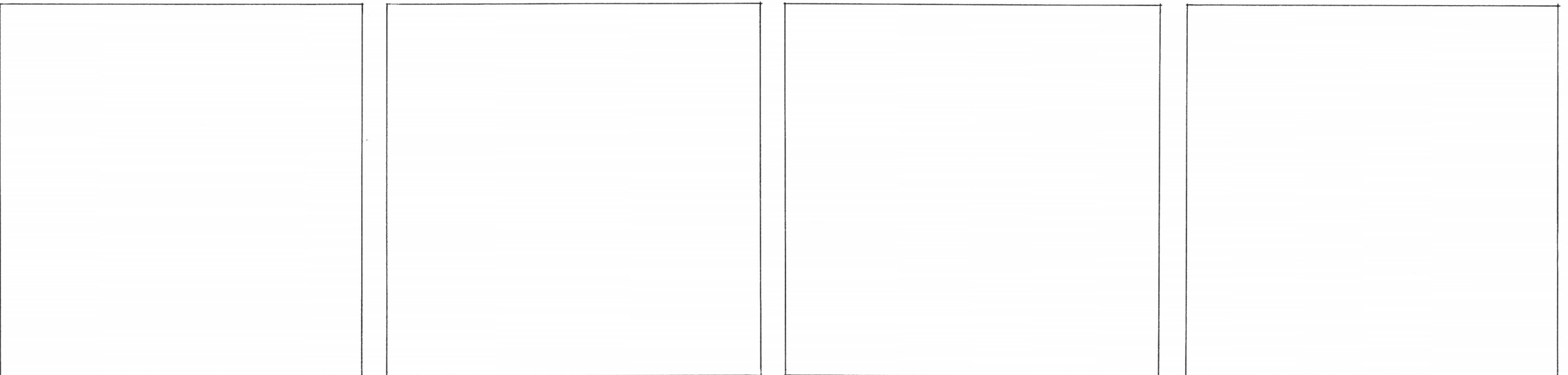
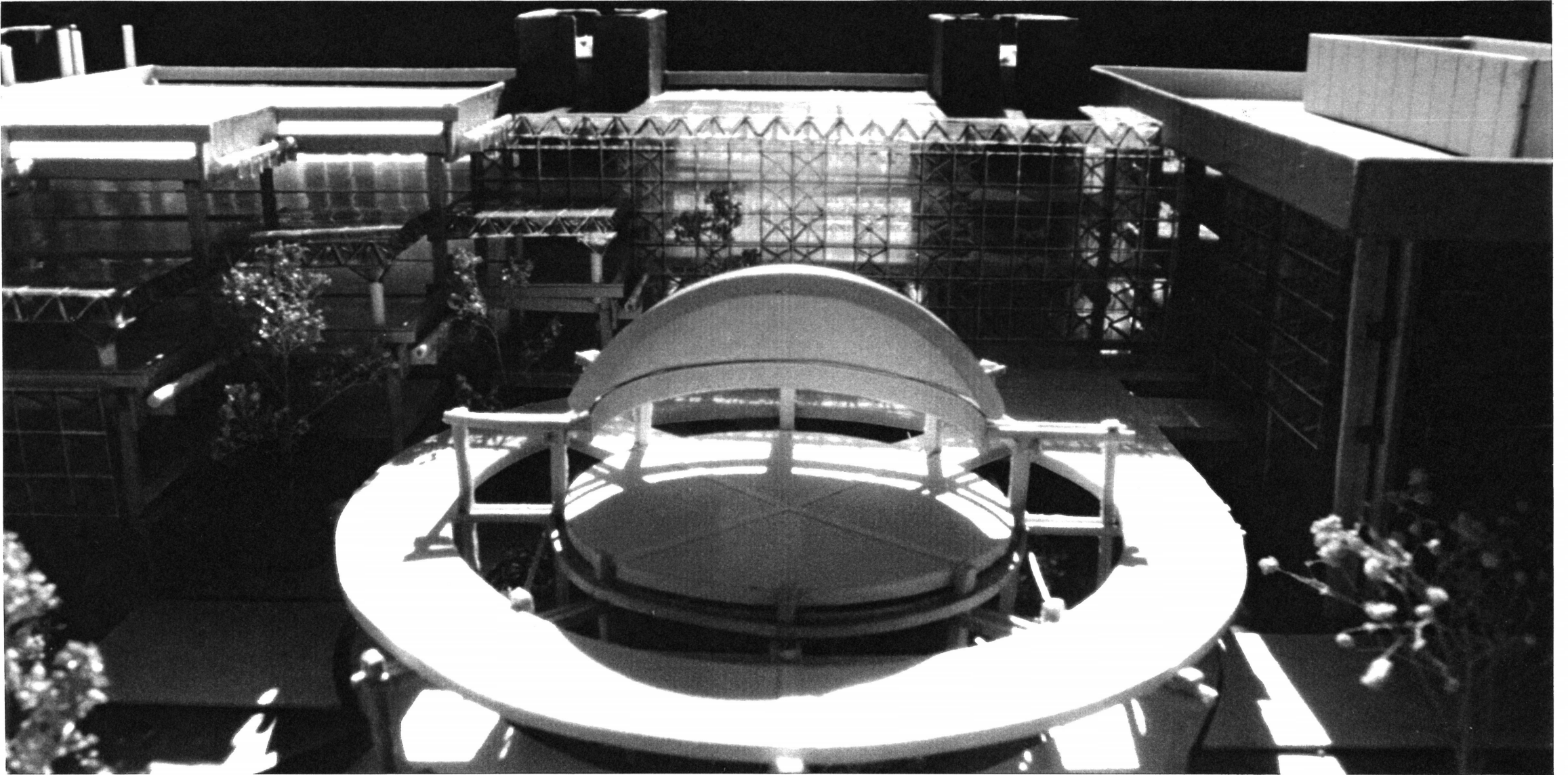

## THE STRUCTURE

The open and exposed form of the structure, much like our society, expresses the individual ideas, elements and acts of making that contribute to the rules of the ordered whole.

The form of the structure continues to evolve in plan and section, as the elements, the frame, the wall, the towers and the dome, are integrated and further defined by a desire to express the zoning of the building and the natural attrition of the student body, through the vertical reduction in floor area and the transparent horizontal layers of the structure.

The transparent nature of the structure reveals a range of spaces that accommodate the social needs of the individual, the few and the many. The structure also encourages visual observation of the design process and expresses the human resource as a primary element in the composition.

The principle of structure has moved in a curious way over this century from being "structural honesty" to "expression of structure" and finally to "structural expressionism." Structural integrity is a potent and lasting principle and I would never want to get far away from it. To express structure, however, is not to an end in itself. It is only when structure can contribute to the total and to the other principles that it is important.

Eero Saarinen

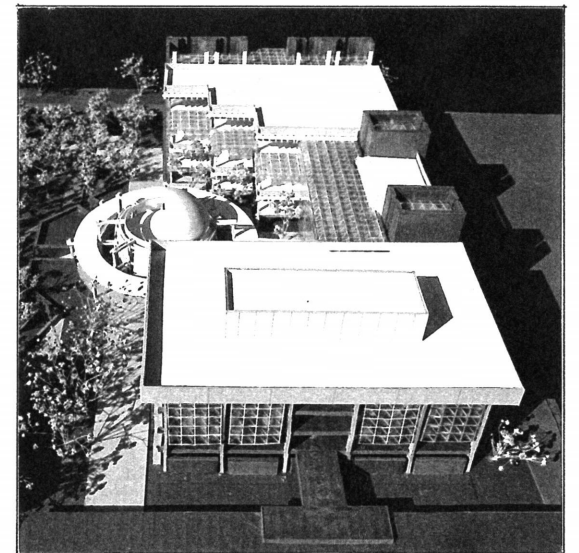

The first level of the structure accommodates the first year studios, shop areas, lecture and exhibition spaces, and support facilities. This level also facilitates pedestrian circulation to and from the commuter parking area to the engineering departments and the second level exhibition and plaza spaces.

The second level of the structure accommodates the second and third year studios, lecture exhibition spaces, administrative and support facilities. This level also facilitates the pedestrian circulation to and from the plaza areas, the heart of the university and the commuter parking area.

LEVEL ONE

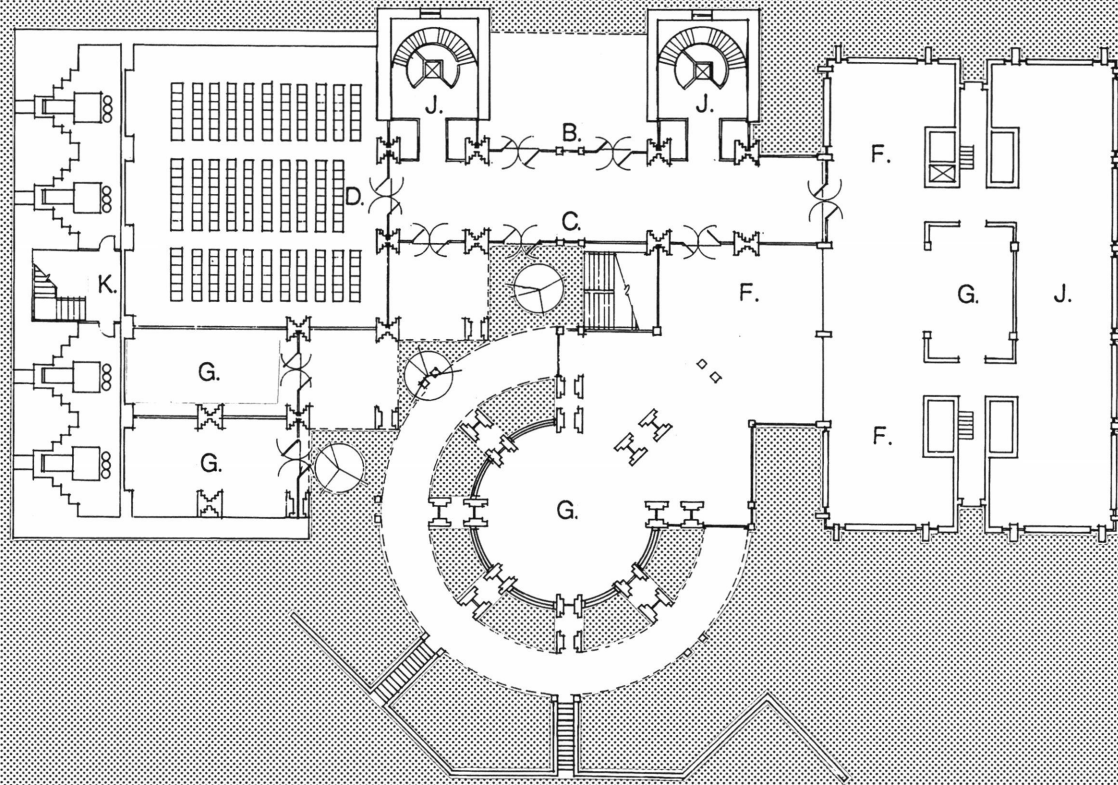

LEVEL TWO

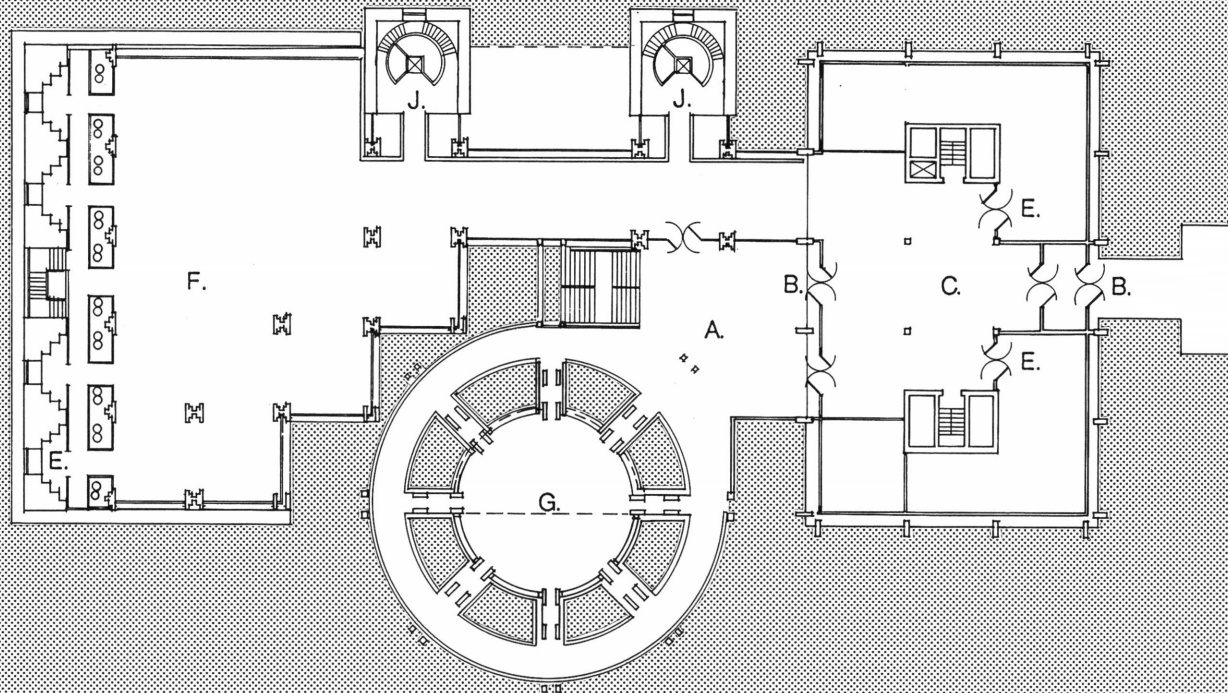

- |    |                    |
|----|--------------------|
| A. | PLAZA              |
| B. | ENTRY              |
| C. | LOBBY              |
| D. | AUDITORIUM         |
| E. | OFFICES            |
| F. | STUDIOS            |
| G. | LECTURE/EXHIBITION |
| H. | LIBRARY            |
| I. | TERRACE            |
| J. | SUPPORT FACILITIES |
| K. | MECHANICAL         |

PLANS

The third level of the structure accommodates the fourth and fifth year studios, lecture and exhibition spaces, and support facilities.

The fourth level of the structure level of the structure accommodates the graduate student studios, research areas, exhibition and lecture spaces and support facilities

LEVEL THREE

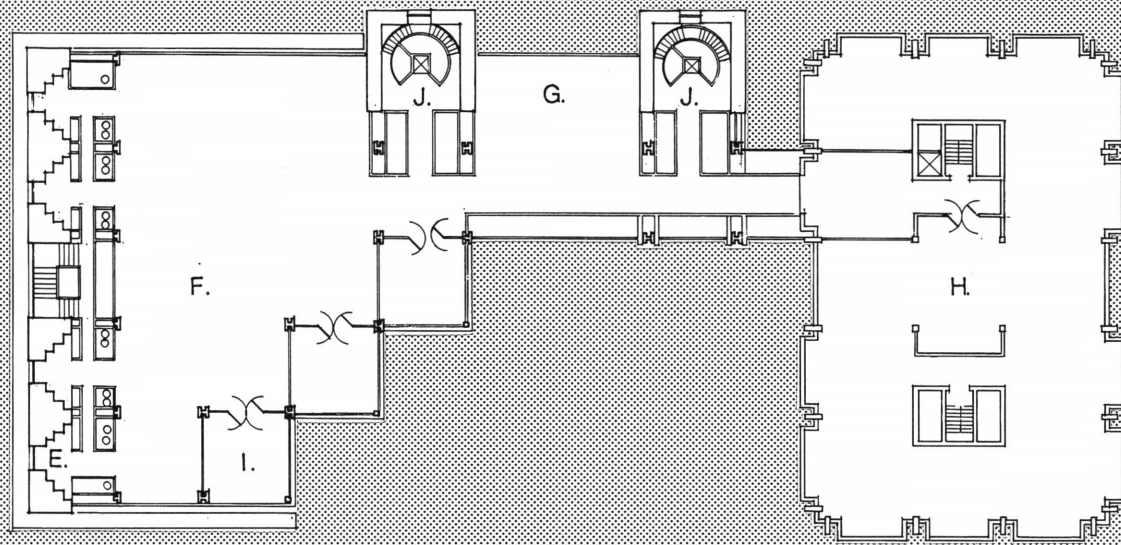

LEVEL FOUR

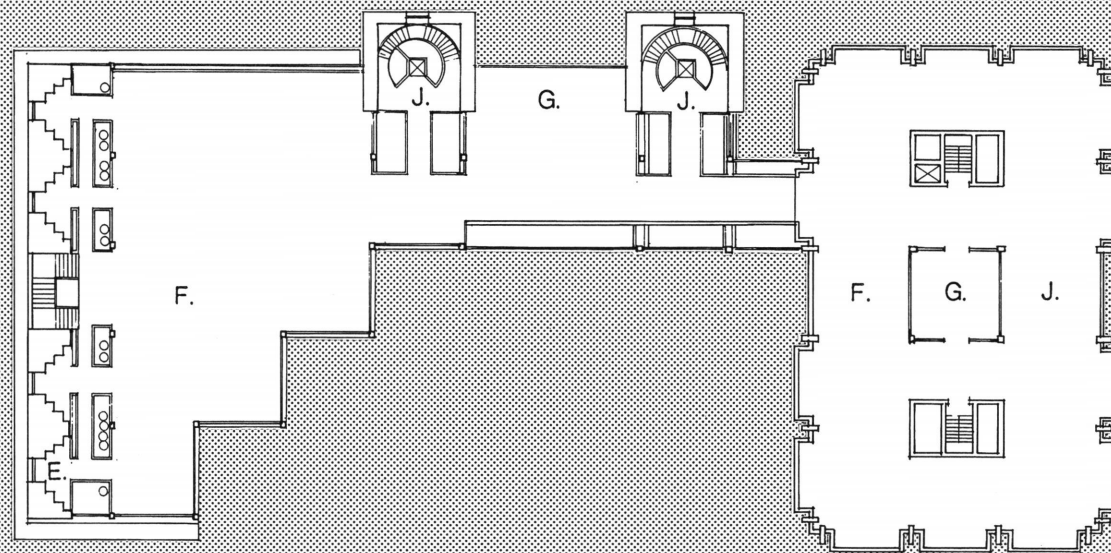

- |     |                    |
|-----|--------------------|
| A.  | PLAZA              |
| B.  | ENTRY              |
| C.  | LOBBY              |
| D.  | AUDITORIUM         |
| E.  | OFFICES            |
| F.  | STUDIOS            |
| G.  | LECTURE/EXHIBITION |
| H.  | LIBRARY            |
| I.  | TERRACE            |
| J.. | SUPPORT FACILITIES |
| K.  | MECHANICAL         |



## THE SECTION

The transparent language of the structure in section reveals the simplicity of the structural systems that order the additive language of the composition. The additive language of the structure creates the flexibility to interpret and translate the building systems into a language that expresses those ideas through the architecture of the built form.

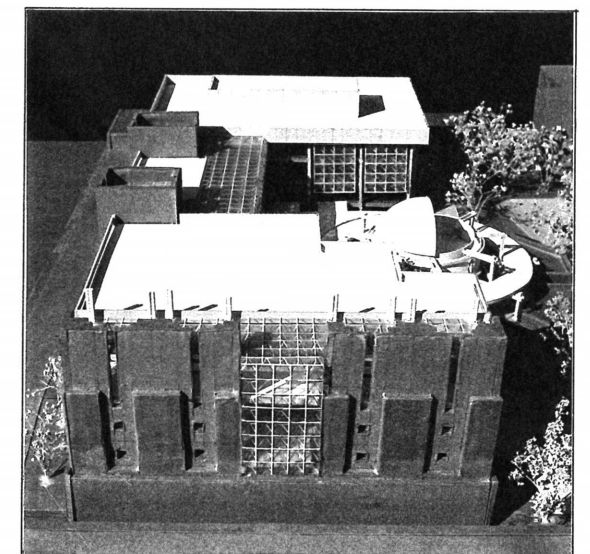
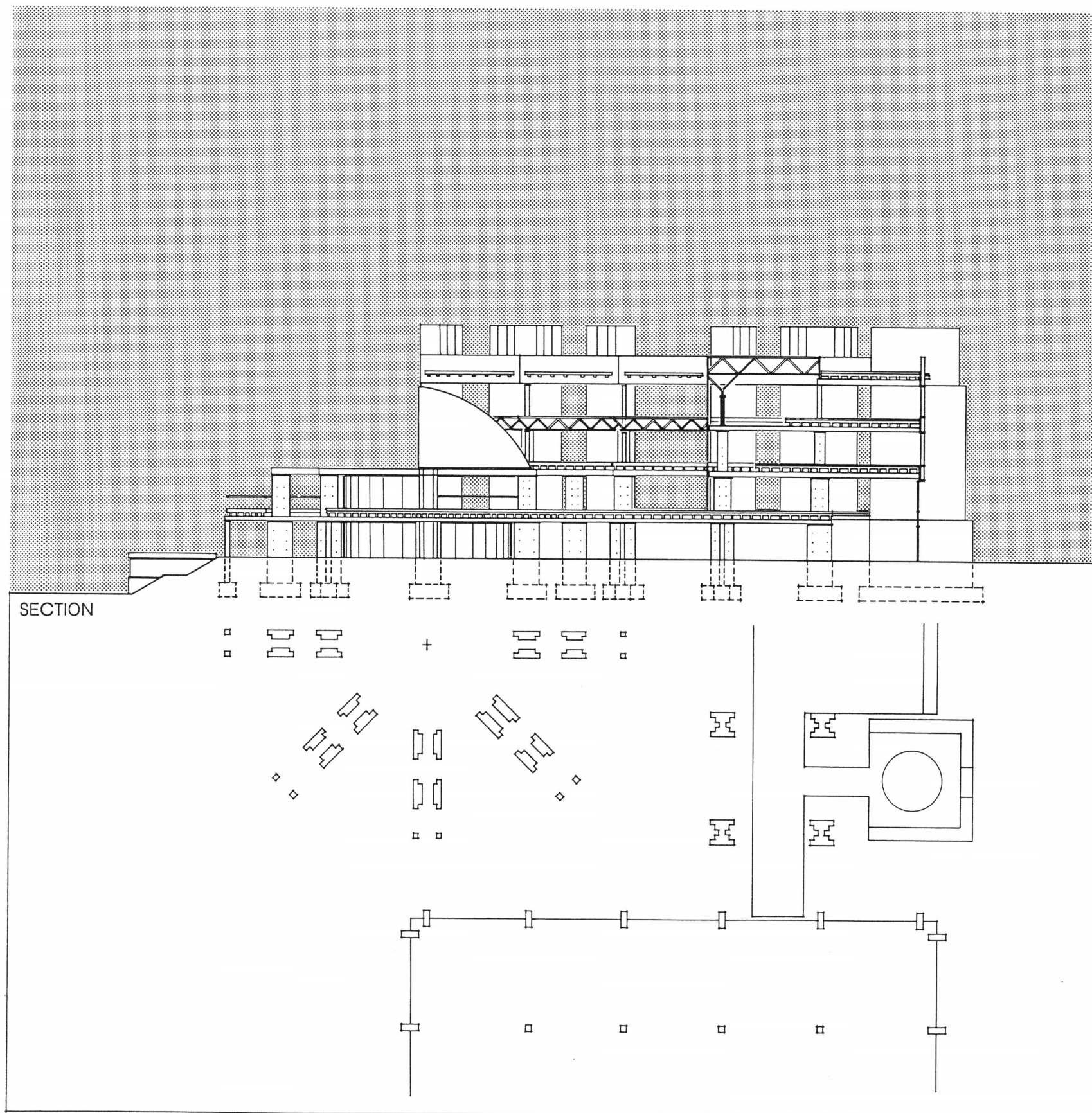

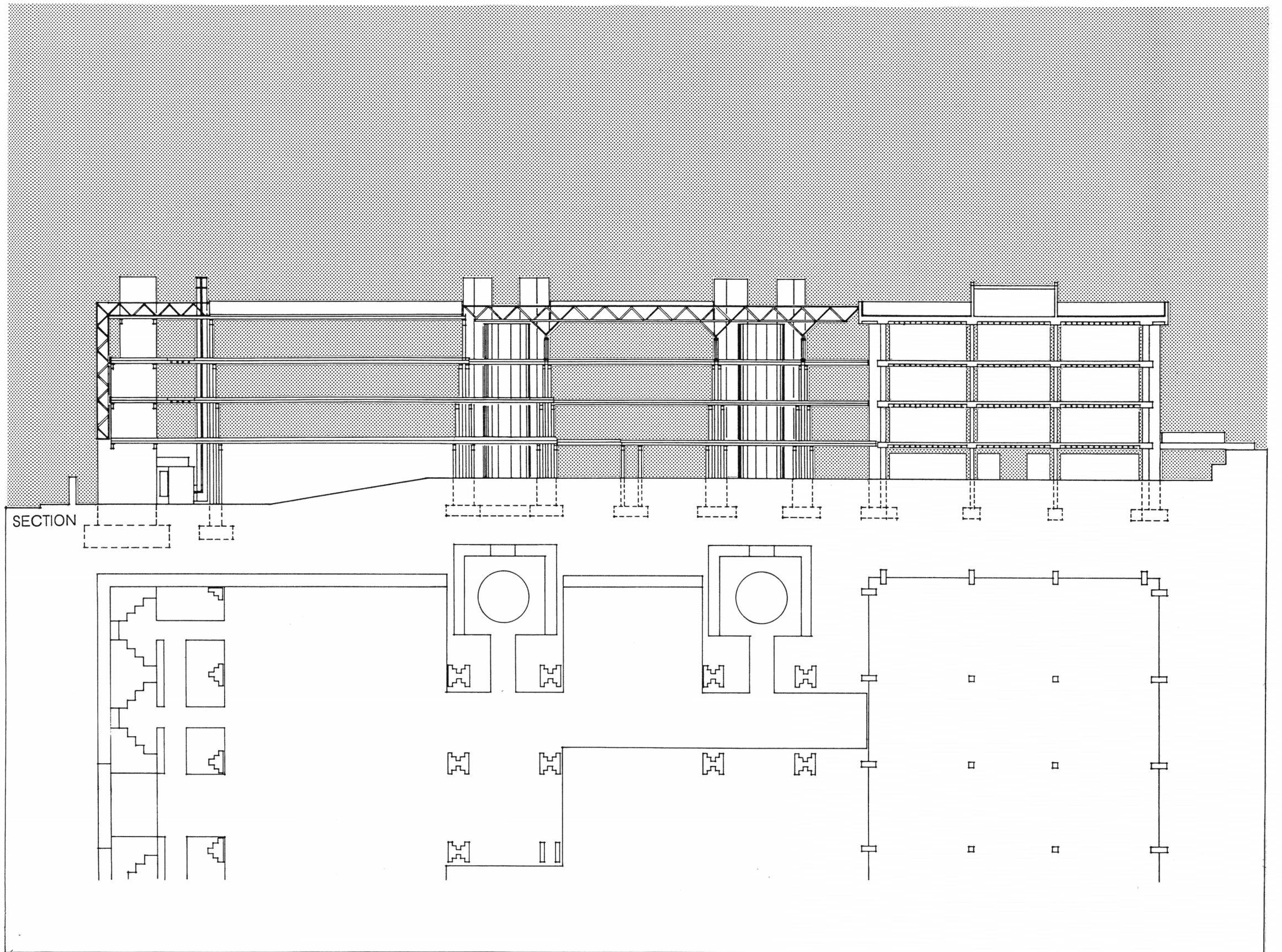

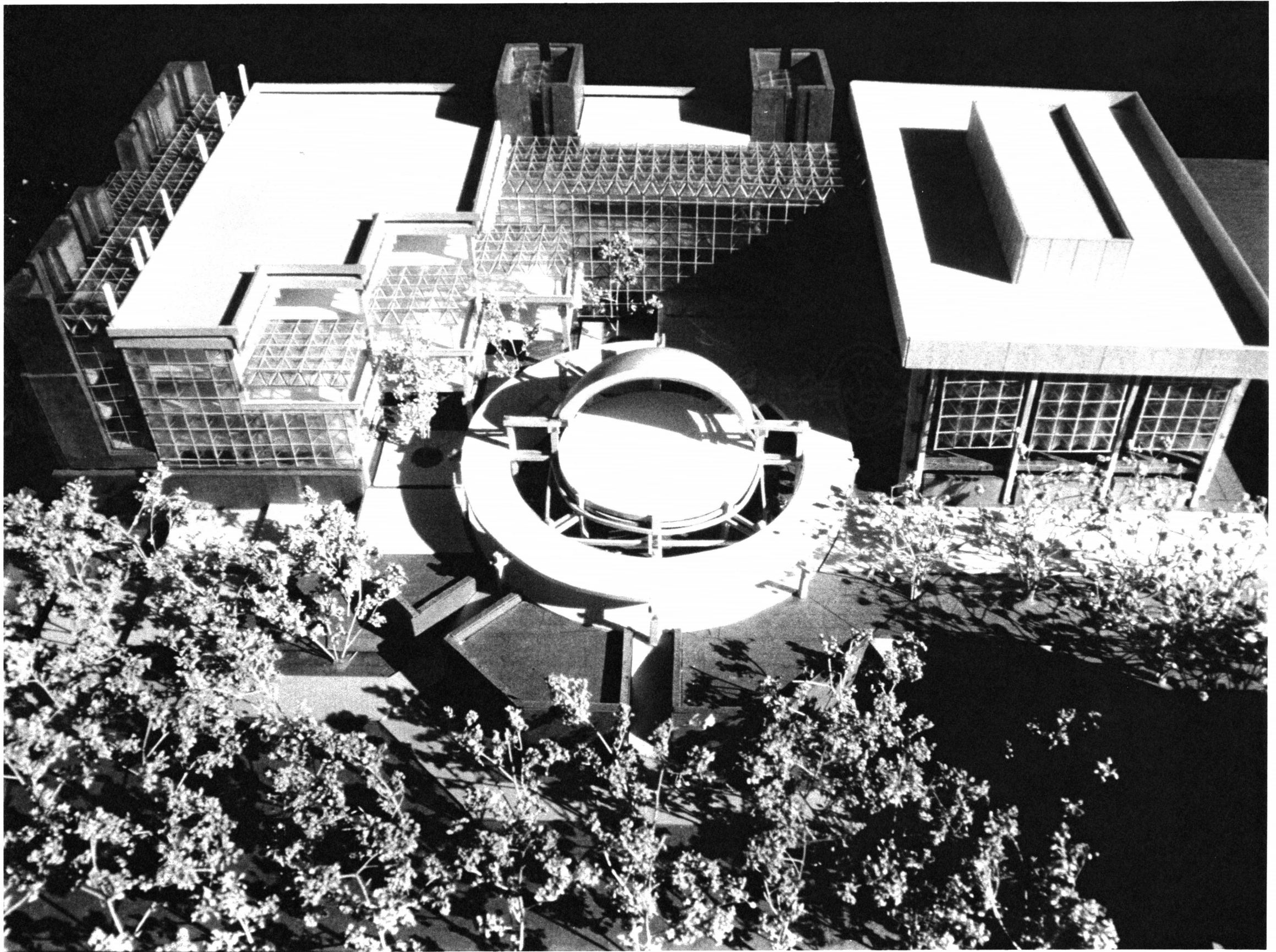

## CONCLUSION

This thesis investigation has been a personal commitment to the architectural medium and the development of a foundation from which my search for truth, understanding and architecture could continue through time.

The goals of this design investigation were to create an academic environment, that is in harmony with it's community, that utilizes the human resource and the structure of the building as a teaching element.

The objectives are pursued through the discovery of appropriate ideas that order the form of the building, and an architectural language that expresses those ideas. They are explored through the relationships of the structure to the site, the elements that compose the structure, and the structure as a whole. These objectives are achieved by the following:

1. The development of a site specific solution that is considerate to the context of the site, existing structural conditions and the specific ideas of institution.

2. The development of an additive infill language of columns, beams and gravity walls that expresses the simplicity of structural systems and the individual acts of making that contributed to the form of the elements.

3. The transparent horizontal layers of the building which encourage the individual student to utilize the human resources and the structure of the addition as a teaching element.

The end result was a building solution that integrates the languages of the academic community, into a form, that expresses an open and harmonious environment. This idea of place, foster's the act of gathering, observation and dialogue between the institutions population, and encourages the individual students to utilize their human and structural resources as they search for truth, understanding and a methodology of making form.

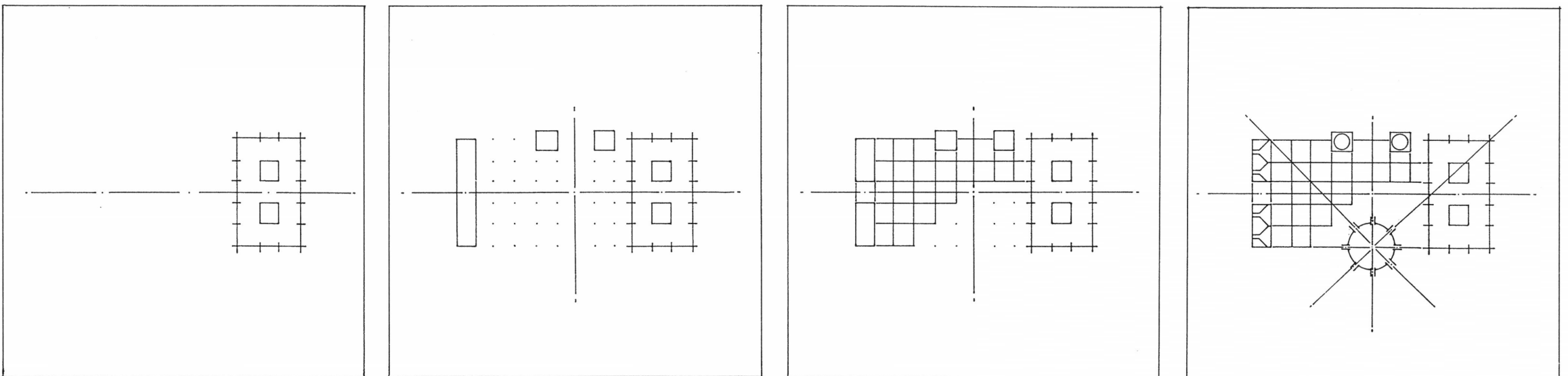

**The vita has been removed from  
the scanned document**

## SOURCES

1. Benedikt, Michael -  
For An Architecture of Reality  
Lumen, New York, 1987
2. Lobell, John -  
Between Silence and Light, Spirit  
in the Architecture of Louis I.  
Kahn  
Boulder: Shambhala. 1979
3. Morris, A. E. J. -  
Precast Concrete in Architecture  
London: The Whitney Library of  
Design, 1978
4. Saarineen, Aline -  
Saarineen on His Work  
New Haven and London: Yale  
University Press, 1968
5. Saarinen, Eiel -  
The Search for Form in Art and  
Architecture  
New York: Dover Publications,  
Inc., 1985
6. The New Boston City Hall -  
Progressive Architecture  
April 1963, page 133
7. V.P.I. and S.U. -  
1983-1993 Master Plan: Concepts,  
Data and Strategies for  
Implementation  
Blacksburg; V.P.I. and S.U., 1984
8. Whitman, Walt -  
Leaves of Grass  
New York: Aventine Press, 1931
9. Wurman, Richard -  
What Will Be Has Always Been. The  
Words of Louis I. Kahn  
New York: Acess and Rizzoli, 1986

