

of land and sea: **A BRIDGE**

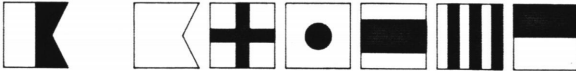



*MASTER'S THESIS - 1993 - VPI*

*dedicated to [redacted] for her patience and support*

*special thanks to [redacted]  
for selected photographic contributions*

AN OCEANOGRAPHIC RESEARCH FACILITY

by

Phillip Scott Craig

Thesis submitted to the faculty of the Virginia Polytechnic Institute  
and State University in partial fulfillment of the requirements  
for the degree of:

MASTER OF ARCHITECTURE

in

ARCHITECTURE

approved:

\_\_\_\_\_  
M.J. O'Brien - Chairman

\_\_\_\_\_  
A. Jack Davis

\_\_\_\_\_  
Frank Weiner

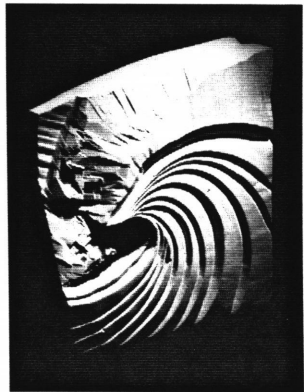

May 1994  
Blacksburg, Virginia

## acknowledgement

*One does not arrive at architecture through idle curiosity*

*"Nothing in art is strictly and completely original with its creator. He has been inspired by many things, past and present, sometimes imitating them but always eventually assimilating them if he is a real artist. The original works of others, the nature of materials, methods, principles and revelations of science, faith and more also give him roots from which to grow."*

Bruce Goff

The memorable events and experiences of our lives manifest themselves in all that we pursue. My childhood experiences on my grandfather's farm and a construction project more than a decade old forever refresh my thoughts of who I am and what I will become. I acknowledge their influence and pay tribute to their memory.

### *The Farm - a well-planted seed*

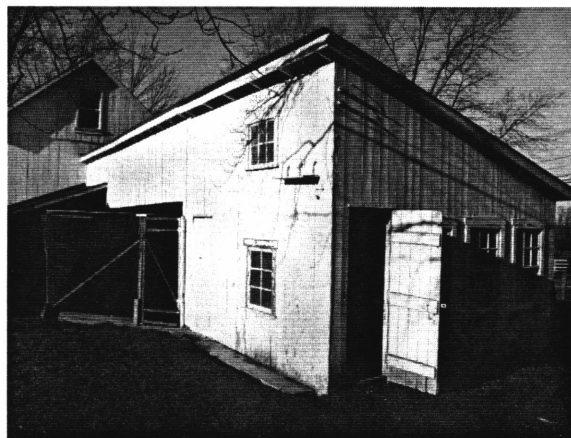
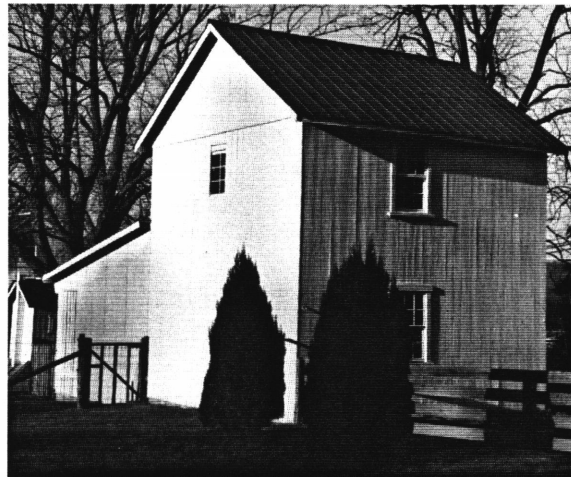

In the playground of the children's children's children, I saw generations and in that light recalled Tradition, Heritage, and myself.

The young boy sat at the old man's side and listened carefully for words; rare words; words that spoke of farm, of family, of building and work. Inside the broken body of years of toil and behind the clear blue eyes that crossed time in a single sweep dwelt a spirit and wisdom of great strength. It was the Farm that would forever evidence that strength. It was the Farm; its images, its experiences that would mold me.

The twenty-six acres nestled between two small hillsides. Its small stand of maples and walnuts yielded abruptly to the upper meadow, the lower meadow, and the dividing brook. Exactly where were the woods and the meadow the same? At what spot were you both under cover and in the clearing? Stub foundations, partly consumed by time and nature, claimed their foothold in the past, present, and future, as they roused the young imagination.

The animal shelters; schools of miracles, stood tall and strong and boasted fine timbers and proud exact joinery. The hay barn nearby was large and open and housed the twine-bound building blocks of childhood fantasies. In the garage and its garret above, the relics of occupation lay dormant; rough sawn planks of white oak and walnut, rusted rip saw blades of water powered mills, a single plow steel of imperfect cast.

In the home a man's passion was exposed. From the knotty pine kitchen cupboards that shrank and swelled in step with the seasons; to the solid walnut staircase with winder treads and crisp, clean-tooled edges worn soft by the hand's caress, to the carved locust cane that was his leg.

The Farm. Host to life and living.

## 1210 West 8th St.

*a seduction of sorts*



In 1979 I joined the wave of urban renewal fanatics that had mounted an assault on the cities. Our resolve was to change the character of the city while making a profit. Through homesteading and tax credits for historic renovations, we were determined to revive the city's vanished sense of decency and respectability. Once again, the local chapter of "real estate agents anonymous" was exercising mind control. I yielded to their suggestions and purchased my first house.

Born in 1910, she was splendid a three-story Victorian in a once prestigious area known as "Capitol Hill". After years of fluctuating demographics, shifting housing patterns, and numerous entrepreneurships, she rested quietly, a broken down, sagging, rotting, six apartment shadow of her former self. "You've got to gut em!" they said. Not one to ignore good advice, I spend the entire summer ripping out and removing tons of lath and plaster, mouldings and millwork, as well as six apartment's worth of refrigerators, ranges, tubs, toilets, sinks, and sixty or more cast iron radiators. Hulking in the dark, dank basement, a great iron octopus posing as a furnace, slowly succumbed to a week of sledge hammering. I traded all the scrap iron for hauling services from one of many self-employed businessmen anxious to get in on the act. At summer's end; three clear span floors, pocketed into their double wythe brick bearing walls, awaited new entrails. The struggle that lay ahead would represent the greatest challenge of my life.

I wasn't entirely new to the construction field. Summers on a highway surveying crew, a number of steel and vinyl liner swimming pools, a few decks, garages, and minor additions, all contributed to a rudimentary understanding of the basics.

All the work up to this point had been premeditated. It was governed by a preset plan with predetermined ideas and methods of execution. I need not think, just produce. 1210 West 8th St. was to be an abrupt departure.

Although I was still teaching school full time, every moment outside of school was consumed by the urgencies of the house. I found an exciting challenge in the solving of myriad technical problems such as the proper way to flash a sloped parapet or how to install cedar shingles on a flaired turret. My skills as a woodworker were tested as I scrupulously reproduced mouldings, support brackets, and frieze board details. Time and nature introduced major structural concerns. The two-story turret had settled six inches and required extensive jacking and shoring. The turret load resolutions required the reconstruction of badly deteriorated pin joint brick arches. While the many technical problems of the building were solved through careful thought and research, it was the problems and questions of design that provided the greatest challenge and excitement. Where should walls and stairs be placed? How would I make use of a brick party wall? What are the possibilities in three open spaces sixteen feet by eighty feet? There was great frustration and reward in every decision. Each instance of design seemed to reveal something of the next one. In time a larger order emerged: an order that advanced not by "idle curiosity", but through painstaking effort and heartfelt desire for the work. In retrospect, it represented the birth of an architectural understanding: An architecture as a collaboration among *Aesthetic sensibilities*, *Material sensitivity*, and *Structural intent*. Often overlooked but perhaps more important came desire. As Ralph Waldo Emerson stated: "Nothing can be done without enthusiasm."

contents



---



---

Cover Page .....	i
Title Page .....	ii
Dedication .....	iii
Signature .....	iv
Acknowledgment--- <i>The Farm</i> ---1210 W. 8th St. ....	v
Contents .....	vii
Abstract--- <i>Of land and sea: a bridge</i> .....	1
Project--- <i>A sequence of imaginations</i> .....	2
Site--- <i>Land is fashioned by water</i> .....	3
Edge--- <i>A moving contour</i> .....	4
Forces--- <i>Wind, Sun, Water</i> .....	5
Images--- <i>A reminder</i> .....	7
Material--- <i>A unifying resource</i> .....	10
Repetition--- <i>Repetition</i> .....	11
Sketches--- <i>Visual thought</i> .....	12
Parts--- <i>Elements of the whole</i> .....	13
Mast/Pile--- <i>A foundation</i> .....	14
Details--- <i>A technical search</i> .....	15
Oceanographic Research Facility--- <i>A solution set</i> .....	16
Configuration--- <i>An arrangement of parts</i> .....	19
Construction--- <i>A building sequence</i> .....	32
Model--- <i>A 3D view</i> .....	33
Conclusion--- <i>A retrospective</i> .....	36
Bibliography .....	37
Vita .....	38

---



---



# Abstract

*Of land and sea: a bridge*

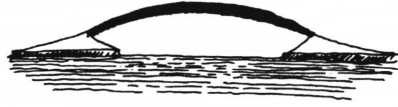

The natures of two contiguous worlds in a dramatic symbiosis inspire a singular expression for the two. The moving, highly energetic, brought to order through regulation; not abruptly, but sensitively, through dynamic forms and moving interactions. Land joins water and forms a critical edge that through the mechanism of change is never fully determined. A moving contour presents a foil to the more orderly, precise nature of man-made construction. A building manifests itself as a bridge that unites the realms of land and water. The orderly progression of structural piles assumes power against the backdrop of an unordered field. Suspended pathways traverse the field, uniting the realms and organizing the waterfront. It is the nature of connection: the union of two made possible by a third. Beyond the connection implied of two contiguous realms, a larger order poses its question. What is the sense of belonging; the intimate connection; belonging to and of this place? Validation extends from referencing the immediate site and surrounding area. Perceived and associative images, as well as indigenous forces inform the design and help determine the forms and manner of execution. The exigencies of the site provide the framework for expression. From the Poetics of Gardens: "Sometimes the most poignant qualities of site come not from what is actually there but from what is connected to it through time and space, by our recollections and hopes." An Oceanographic Research Facility, derived from forces and forms indigenous to the coastal milieu, emerges as a platform to experience Land and Sea and by definition, unified: joined in a common sense or relationship.

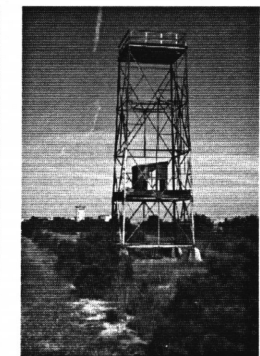
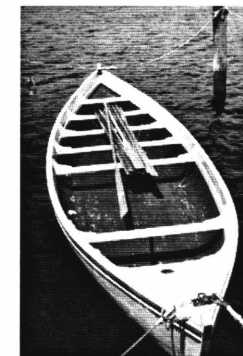
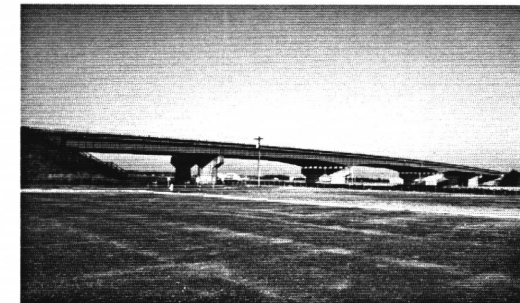
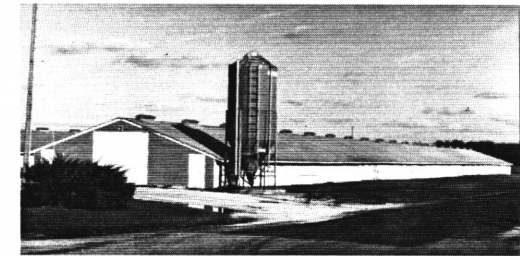

## project

*a sequence of imaginations*

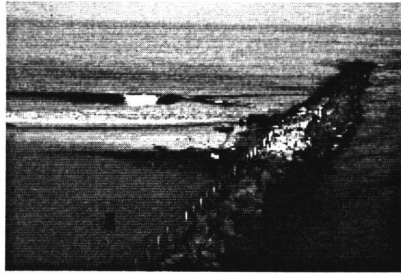

*"We begin again and again..."* Gertrude Stein

*Louis Kahn said, "You discover wonderful things about the nature of beginnings." Beginnings, paradoxically, are not primordial but a continuation; a compounding result of what we know and understand. Too often what we know and understand compromises good beginnings and leads to uninspired conclusions. The "beginnings" of the Oceanographic Research Facility were delivered from the imagination. The ensuing ruminations proved to define the approach to the project.*

The first imagination began as two intersecting lines; a crossing, much like the crosshairs of a surveyor's scope. From the intersection point a thick, bold line spiralled upward and outward forming a cone. At the bottom of the cone, at its most restricted point, rested three words: focus, center, thought. Three words became a foundation, a beginning to build upon and occupy the void of the cone. Along with the spiralling cone and the three words were sentences, wishes, and ideas; all combining to define the project and reveal its scope.

It was to be a combined facility, featuring oceanographic research, marine science, and a natural history museum. There would be research areas, display areas, ample space for the administrative functions that any organized entity requires, and the ubiquitous restaurant that unites us all. Collectively, the facility would foster an understanding of the plight of the coastline and its inhabitants. Through its research and educational programs, it would respond to the rising concern for our vanishing wetlands and deteriorating aquatic habitats.

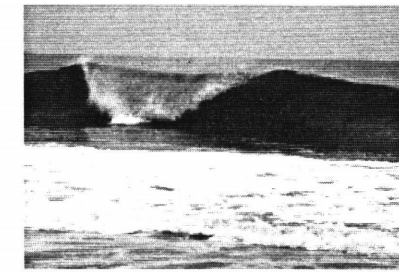

The second imagination was simpler, more direct. It featured a surfer tightly crouched in the hot spot of a head high tube, the frothing curl folding neatly over his shoulder, the hollow muffled sound of the inside, and the regenerating gleaming wall, unfolding, stretching, bowling in sensitive response to the changing bottom below. A man-made groin of dressed basalt armor stone framed the inlet and trapped the travelling swells. Perched at the end of the jetty a forsaken light tower slowly succumbed to the perpetual storm as men at play, filled their senses, casting to the outstretched sea; breathing, tasting, and remembering.

*Two musings clamor for domain and obscure the resolve. Despite the fact that a project is heavily determined by programmatic concerns, it would be remiss to ignore the more essential fuel that drives our efforts. Something beyond square foot totals and adjacency of spaces must jostle the imagination or stimulate the memory and make it part of a larger realm; a realm that connects the past, present, and future. The memory is best served by an examination of the site and its surround. A closer look serves to explore the many relationships and uncover the nature of what exists and more importantly perhaps, the spirit of what came before.*

site

*land is fashioned by water*

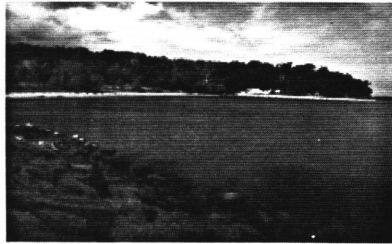

*"Some special places have the extraordinary power to serve as a metaphor for the whole world. The power often comes from a concentration, a reduction to essentials, and its effect is altogether to absorb us, to hold us in the spell of the place ... We have found it useful to call places like these settings. Some settings are big, some small, some can be seen all at once, some must we wandered through, but all achieve, in their disciplined clarity of multi-layered richness, the capacity to fill the mind (and later the memory) with their presence."*

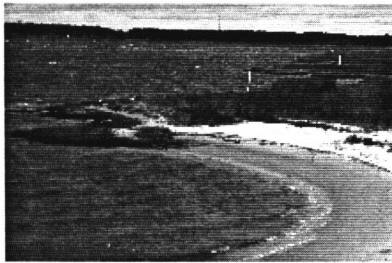

*75° 4' 23" west longitude  
38° 36' 38" north latitude*

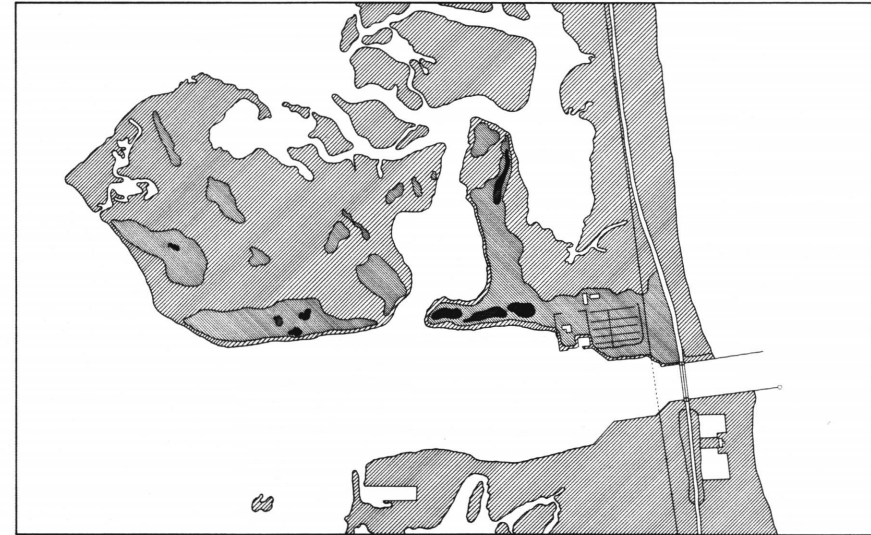

Along the southern coast of Delaware, the Indian River Inlet breaches a barrier island and produces a co-mingling of fresh and salt waters. The resulting estuarial system is the Indian River Bay. It is a system of great variety and change. Expansive open planes of water are punctuated by jigsaw puzzle configurations of tidal marshes and amorphous islands of higher ground stabilized by beach grass, bay-berry shrubs, and assorted reeds. Just as land is fashioned by water, water derives its form from the land it invades. Three bodies share a common address and participate in each other's existence. The **Sea**: an immense force that disperses energy and effects continual change, the **Inlet**: a relief valve; a constricting vessel that captures energy and accelerates it, **Balder's Pond**: a calm shelter and refuge for the dissipation of the fluid charge. Through the commonality of water the landscape is truly rendered. On the open waters a slow tidal erosion consumes the short stubby patches of mud-bound growth and moves them to a new post. In the more sheltered areas, clustered trees of short stature abound and provide a stronghold against nature's hunger.

The land and water endure together and share in moods and magic and time everlasting. As an afternoon glow highlights land's grassy edge and freezes a wood block in a glassy plane, or shards of light fly from a sun dappled surface, or the day expires and paints its chromatic delight, the SITE reveals all and invites participation.

edge

*a moving contour*

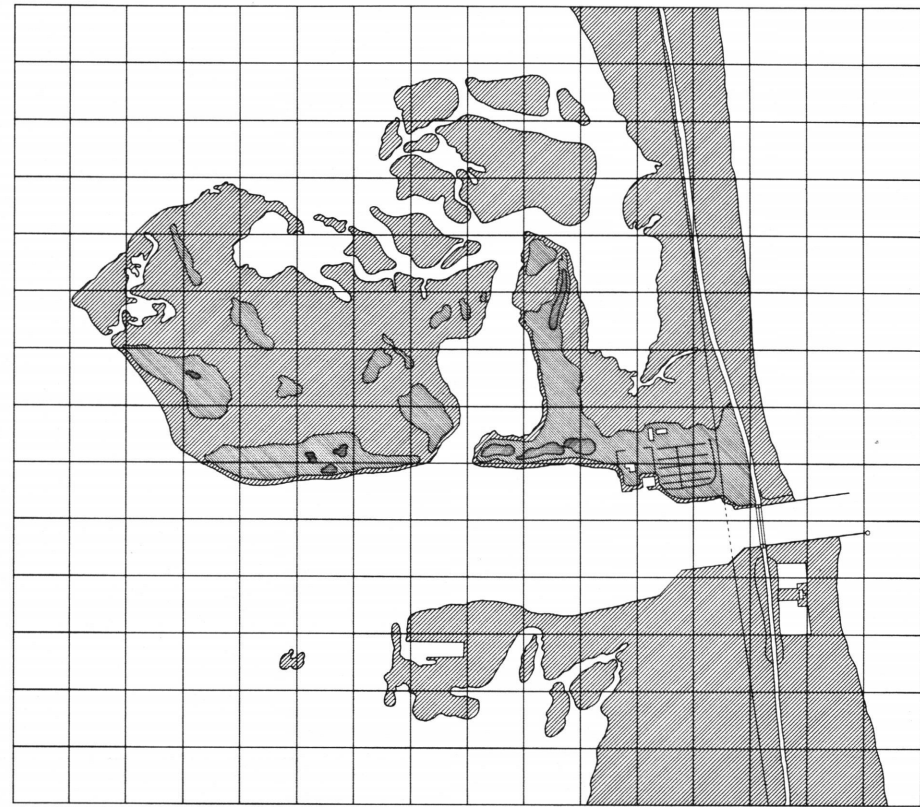
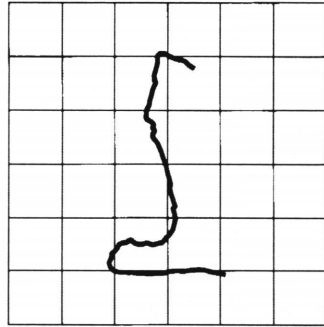

A critical edge by the mechanism of change is never fully determined. Man-made attempts to stabilize and define are only temporary, thwarted by the resurgent sea and scouring action of the flowing tides. The land figure eludes description and becomes apparent when referenced to a known benchmark. An orthogonal grid based on North-South, East-West compass bearings is a building plan that establishes a reference for the "moving contour." A static configuration imposed on a dynamic one becomes interactive.

# Forces

*wind, sun, water*

*Technology permits man to ignore the natural forces that buildings encounter. A more conscientious approach embraces the elements of nature and uses them as design parameters. It recognizes that buildings and natural forces are intimately connected and require sympathetic attention.*

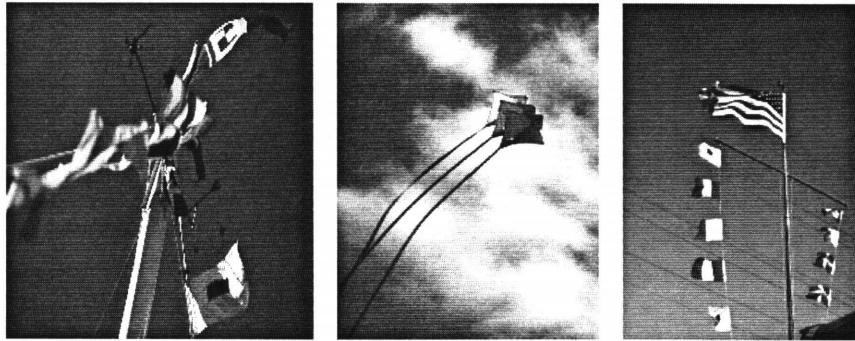

## wind

Total stillness is a rarity along the seashore. For the most part, breezes reign. From gentle wisps of air to a gale-force barrage, wind is cyclical, timely, and a perpetual natural presence. Resulting from the distribution of air pressure as a function of solar activity, it moves in every direction at varying velocities in a shifting, fluctuating, unpredictable choreography. Wind touches all. In its dead calm moments it lends the surface of Balder's Pond a placid and glass-like serenity. As a wailing "Nor' Easter", it whips the ocean into a raging frenzy. It sculpts the sand dunes into long, low-sloped leeward sides and abrupt, hollowed, windward sides. It forms miniature wave-like ripples on flat beach sand and, with sand blasting particles, softens the edges of glass and prematurely ages the surface of wood. A building that acknowledges the presence of wind responds to its nature. In recognizing it as a perpetual force, the building presents no broad faces of confrontation, but assumes forms that allow the wind to move above, below, and through the structure in all manner of orientation.

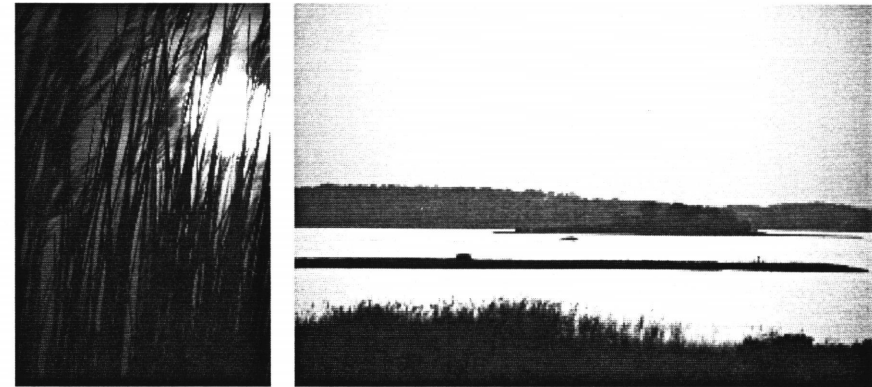

## sun

As a broken sunbeam glitters its path across the wind-rippled surface of Balder's Pond, a natural presence is felt. The sun is time and its perception is felt in a daily as well as a seasonal sense. From morning to noon to night, its life-giving light highlights and obscures the many details of the visual world. At its apogee on a summer's day, it saturates the landscape with a burning intensity. At the day's end, travelling through vast distances of atmosphere, it paints masterly and produces forms out of objects by way of great shadow-giving powers. From summer through winter to summer, its seasonal track is apparent. Winter's path is the shortest; rising and setting to the south and climbing only half-way into the sky. In summer the sun reaches almost directly overhead as it sweeps a long daylight path beginning and ending farther to the north. To ignore so formidable a force would be neglect. To capture and utilize the sun's great power is conscientious. The buildings of the Oceanographic Research Facility, acknowledge the sun and, by responding to it in a manner both technical and aesthetic, magnify its purpose.

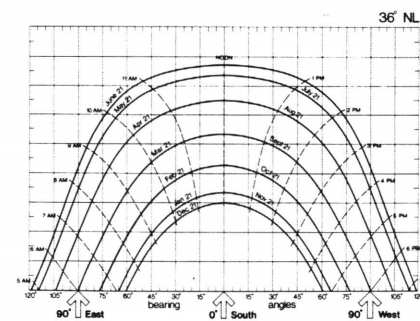

water

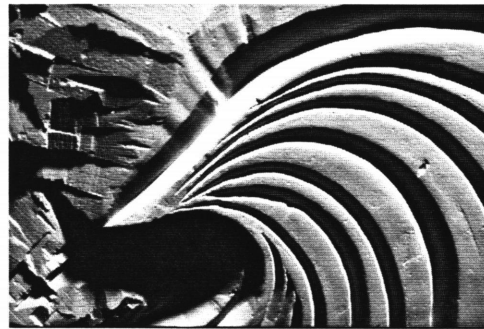

"Water not only provides a basis for man's existence and a continuous challenge to secure its use, but it is a source of metaphysical symbolism, aesthetic pleasure, and therapeutic value. Water gives expression to nature's moods and provides substance to seasonal change. Landscape is fashioned by water which, as cascades, resurgent sea, or reflective calm, bear witness to a beneficial universe." The water flowing in and around the Indian River Bay is an agent of change. In a physical sense, its powers of accretion and erosion compete to determine the figure of the land mass. As a surface upon which the sun, moon, and wind execute their dance, it registers the range of human sentiment. In a more primal sense, it is the heartbeat of the coastal surround. Through a perpetual tidal cadence, water marks time and affirms the cyclical aspect of existence. It is the backdrop upon which experience is measured. Buildings attempting to conquer and control water are forever surrendering. Those that recognize water as an opportunity endure. Opportunity suggests that as we build by the water we enter into partnership with it; we respect its nature and confirm it in our endeavor. By being on and of the water, buildings participate in water's character and share in its multitude.

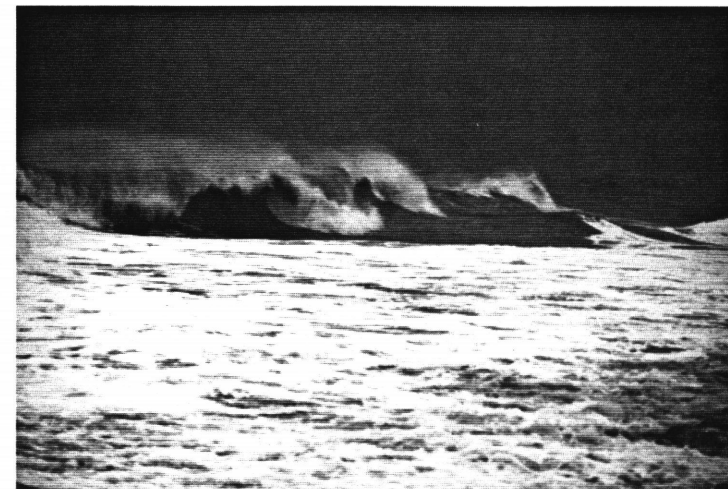
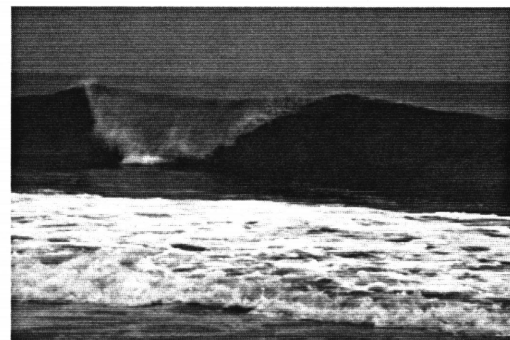
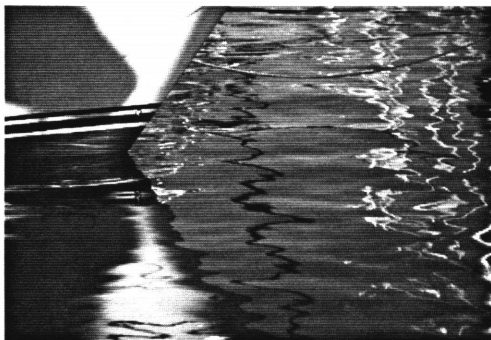

**1993  
INDIAN RIVER TIDE CHART**

Point		High	Low	Oak Orchard	02:10	03:20														
Indian River Bridge		01:00	01:10	Platinum Point	02:25	03:15														
Turkeyfoot Acres		01:10	01:20	Delaware Bay (Breakwater)	01:00	01:00														
<b>D</b>	<b>MARCH</b>	<b>APRIL</b>		<b>MAY</b>		<b>JUNE</b>		<b>JULY</b>		<b>AUGUST</b>		<b>SEPTEMBER</b>		<b>OCTOBER</b>		<b>NOVEMBER</b>		<b>DECEMBER</b>		
<b>A</b>	LOW	LOW	HIGH	LOW	LOW	HIGH	LOW	LOW	HIGH	LOW	LOW	HIGH	LOW	LOW	HIGH	LOW	LOW	HIGH	LOW	LOW
<b>P</b>	PM	AM	PM	AM	PM	AM	PM	AM	PM	AM	PM	AM	PM	AM	PM	AM	PM	AM	PM	AM
1	0:00	1:30	3:00	4:30	6:00	7:30	9:00	10:30	12:00	1:30	3:00	4:30	6:00	7:30	9:00	10:30	12:00	1:30	3:00	4:30
2	0:30	2:00	3:30	5:00	6:30	8:00	9:30	11:00	12:30	2:00	3:30	5:00	6:30	8:00	9:30	11:00	12:30	2:00	3:30	5:00
3	1:00	2:30	4:00	5:30	7:00	8:30	10:00	11:30	1:00	2:30	4:00	5:30	7:00	8:30	10:00	11:30	1:00	2:30	4:00	5:30
4	1:30	3:00	4:30	6:00	7:30	9:00	10:30	12:00	1:30	3:00	4:30	6:00	7:30	9:00	10:30	12:00	1:30	3:00	4:30	6:00
5	2:00	3:30	5:00	6:30	8:00	9:30	11:00	12:30	2:00	3:30	5:00	6:30	8:00	9:30	11:00	12:30	2:00	3:30	5:00	6:30
6	2:30	4:00	5:30	7:00	8:30	10:00	11:30	1:00	2:30	4:00	5:30	7:00	8:30	10:00	11:30	1:00	2:30	4:00	5:30	7:00
7	3:00	4:30	6:00	7:30	9:00	10:30	12:00	1:30	3:00	4:30	6:00	7:30	9:00	10:30	12:00	1:30	3:00	4:30	6:00	7:30
8	3:30	5:00	6:30	8:00	9:30	11:00	12:30	2:00	3:30	5:00	6:30	8:00	9:30	11:00	12:30	2:00	3:30	5:00	6:30	8:00
9	4:00	5:30	7:00	8:30	10:00	11:30	1:00	2:30	4:00	5:30	7:00	8:30	10:00	11:30	1:00	2:30	4:00	5:30	7:00	8:30
10	4:30	6:00	7:30	9:00	10:30	12:00	1:30	3:00	4:30	6:00	7:30	9:00	10:30	12:00	1:30	3:00	4:30	6:00	7:30	9:00
11	5:00	6:30	8:00	9:30	11:00	12:30	2:00	3:30	5:00	6:30	8:00	9:30	11:00	12:30	2:00	3:30	5:00	6:30	8:00	9:30
12	5:30	7:00	8:30	10:00	11:30	1:00	2:30	4:00	5:30	7:00	8:30	10:00	11:30	1:00	2:30	4:00	5:30	7:00	8:30	10:00
13	6:00	7:30	9:00	10:30	12:00	1:30	3:00	4:30	6:00	7:30	9:00	10:30	12:00	1:30	3:00	4:30	6:00	7:30	9:00	10:30
14	6:30	8:00	9:30	11:00	12:30	2:00	3:30	5:00	6:30	8:00	9:30	11:00	12:30	2:00	3:30	5:00	6:30	8:00	9:30	11:00
15	7:00	8:30	10:00	11:30	1:00	2:30	4:00	5:30	7:00	8:30	10:00	11:30	1:00	2:30	4:00	5:30	7:00	8:30	10:00	11:30
16	7:30	9:00	10:30	12:00	1:30	3:00	4:30	6:00	7:30	9:00	10:30	12:00	1:30	3:00	4:30	6:00	7:30	9:00	10:30	12:00
17	8:00	9:30	11:00	12:30	2:00	3:30	5:00	6:30	8:00	9:30	11:00	12:30	2:00	3:30	5:00	6:30	8:00	9:30	11:00	12:30
18	8:30	10:00	11:30	1:00	2:30	4:00	5:30	7:00	8:30	10:00	11:30	1:00	2:30	4:00	5:30	7:00	8:30	10:00	11:30	1:00
19	9:00	10:30	12:00	1:30	3:00	4:30	6:00	7:30	9:00	10:30	12:00	1:30	3:00	4:30	6:00	7:30	9:00	10:30	12:00	1:30
20	9:30	11:00	12:30	2:00	3:30	5:00	6:30	8:00	9:30	11:00	12:30	2:00	3:30	5:00	6:30	8:00	9:30	11:00	12:30	2:00
21	10:00	11:30	1:00	2:30	4:00	5:30	7:00	8:30	10:00	11:30	1:00	2:30	4:00	5:30	7:00	8:30	10:00	11:30	1:00	2:30
22	10:30	12:00	1:30	3:00	4:30	6:00	7:30	9:00	10:30	12:00	1:30	3:00	4:30	6:00	7:30	9:00	10:30	12:00	1:30	3:00
23	11:00	12:30	2:00	3:30	5:00	6:30	8:00	9:30	11:00	12:30	2:00	3:30	5:00	6:30	8:00	9:30	11:00	12:30	2:00	3:30
24	11:30	1:00	2:30	4:00	5:30	7:00	8:30	10:00	11:30	1:00	2:30	4:00	5:30	7:00	8:30	10:00	11:30	1:00	2:30	4:00
25	12:00	1:30	3:00	4:30	6:00	7:30	9:00	10:30	12:00	1:30	3:00	4:30	6:00	7:30	9:00	10:30	12:00	1:30	3:00	4:30
26	12:30	2:00	3:30	5:00	6:30	8:00	9:30	11:00	12:30	2:00	3:30	5:00	6:30	8:00	9:30	11:00	12:30	2:00	3:30	5:00
27	1:00	2:30	4:00	5:30	7:00	8:30	10:00	11:30	1:00	2:30	4:00	5:30	7:00	8:30	10:00	11:30	1:00	2:30	4:00	5:30
28	1:30	3:00	4:30	6:00	7:30	9:00	10:30	12:00	1:30	3:00	4:30	6:00	7:30	9:00	10:30	12:00	1:30	3:00	4:30	6:00
29	2:00	3:30	5:00	6:30	8:00	9:30	11:00	12:30	2:00	3:30	5:00	6:30	8:00	9:30	11:00	12:30	2:00	3:30	5:00	6:30
30	2:30	4:00	5:30	7:00	8:30	10:00	11:30	1:00	2:30	4:00	5:30	7:00	8:30	10:00	11:30	1:00	2:30	4:00	5:30	7:00
31	3:00	4:30	6:00	7:30	9:00	10:30	12:00	1:30	3:00	4:30	6:00	7:30	9:00	10:30	12:00	1:30	3:00	4:30	6:00	7:30

## images

*a reminder of something that is,  
was, or shall be*

*In addition to having been influenced  
by forces indigenous to the coastal region,  
the design for the Oceanographic Research  
Facility was inspired by a collection of local  
forms and figures.*

### the bridge

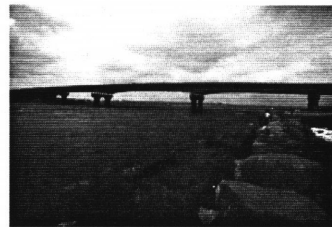

The Indian River Inlet Bridge is a great spanning element that unites the coastline. Poised between two masses of sandy coast, it places two pylon feet into the inlet for added support. It becomes in form a dune; an object of crossing; a metaphor for the struggle of research; paradoxically, that which saves labor still involves work. On an individual scale, the ramps, walkways, and tidal trough of the research facility represent bridges. They are objects that constitute the connection of two things. On a more complete scale, the entire project is a bridge. It becomes a collection of objects that connect land and water in mutual existence.

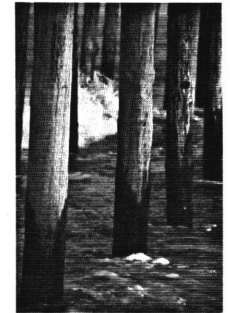
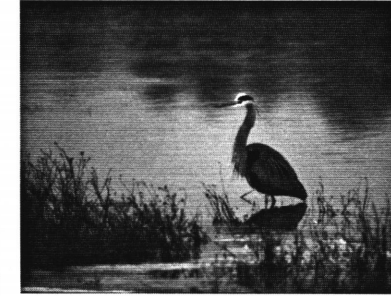

### the pile



The pile constitutes an order. It is a point in a fluid plane and, by default, an anchorage to time and place. As singles or in clusters anchored in the muddy goo, they are fingers of support; a means to hover above or almost touch. As a marine image the pile is indelible. As rotting-out mooring posts for a small skiff, or monstrous legs of offshore drilling platforms, or as an abstraction in the long spindly legs of the great blue heron, the pile is pervasive, utilitarian, and a romantic vehicle for the imagination.

## shacks

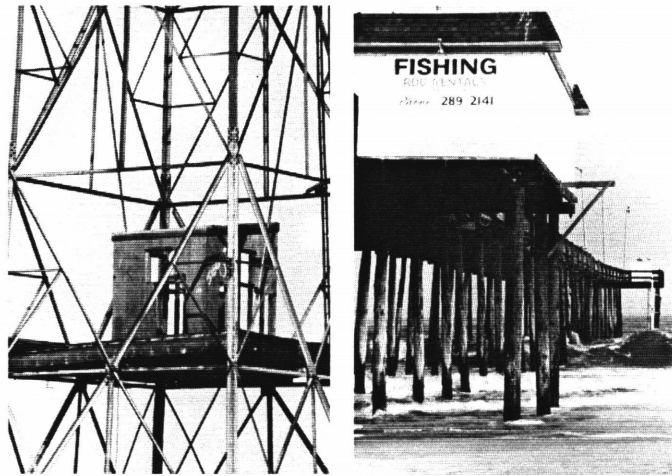
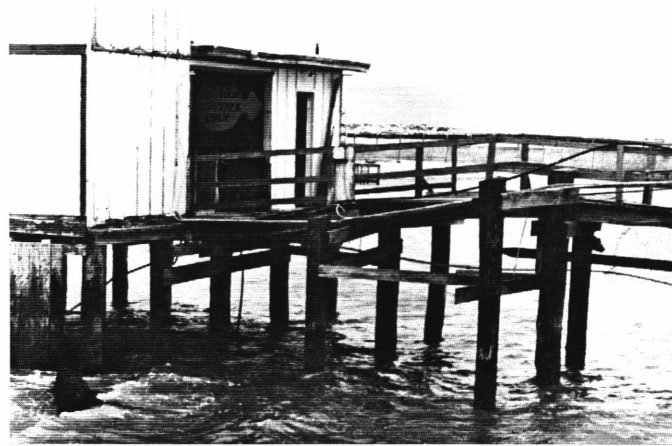

"House in a house." A house in the steel tower is a unit in the frame. The surrounding enclosure is transparent and thereby promotes full expression of the unit within. Although connected to the tower structure, the house is tenuous in nature; a separate entity appearing to touch and just pass through.

"House on a house." A supporting arrangement of piles provides a platform for structures to roost. The dissolution of the mass into fingers of strength is a transformation of the whole and an expedient method of resolution.

## canals

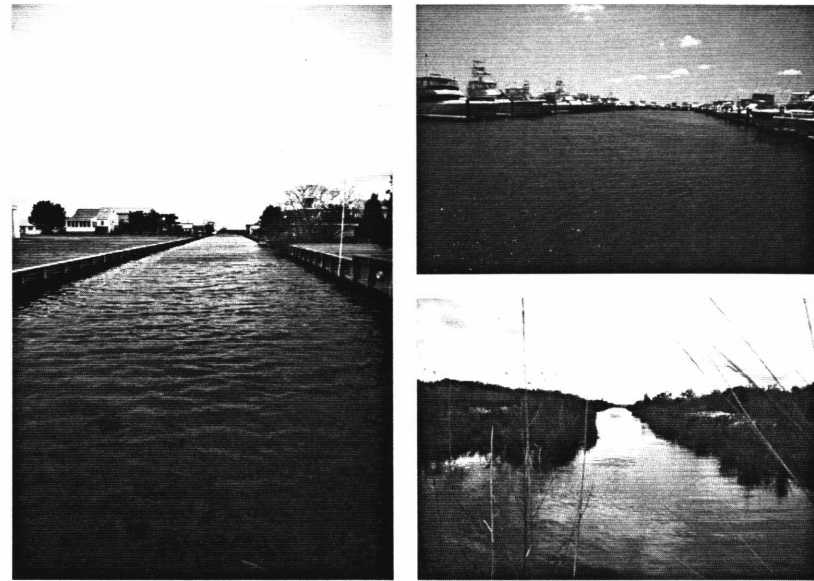

"Streets of water." Hewn from land, canals are a means to organize the flow of water. As mere drainage ditches or full bulkheaded pathways, they control movement and demarcate the land mass. Strings of laboratories, in their regular gridded array, produce the canals; the linear expanses of flow, the "Streets of water."

## mooring posts

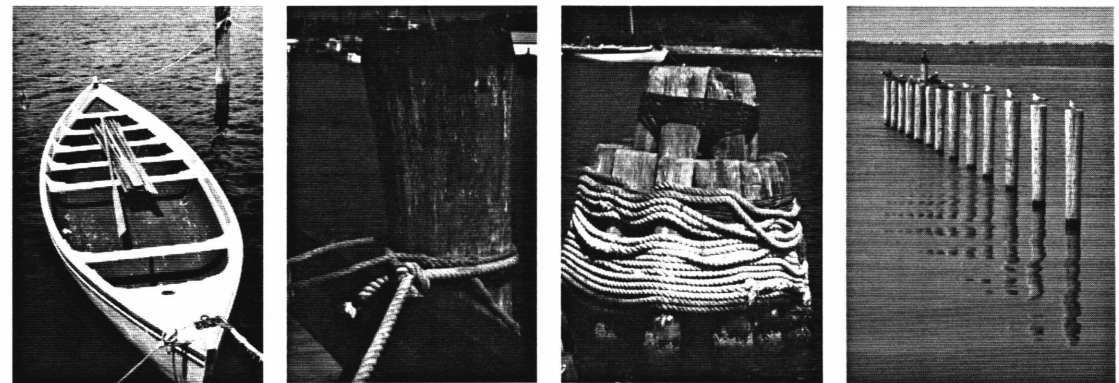

"Restraint." As a small row boat gently drifts between two mooring posts, an iconic image emerges. A system of restraint that allows for a flexible adaptation to changing conditions becomes appropriate. The posts are the agents of strength and, in their configuration, define the boundaries of the entity between. The laboratories, joined end to end like a string of boats, acknowledge their existence through the mooring masts at the extremities.



## the gull

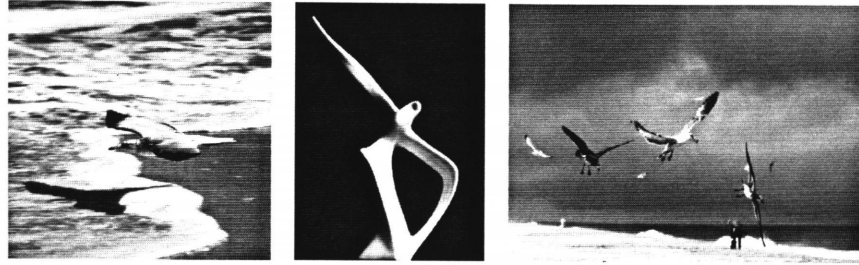

One bears witness to the precarious balance of the sea bird in flight. Magically hovering in the face of the wind, it delicately adjusts its wings, rising and falling in response to the deflected air. The wing manipulates the breeze as the gull, seemingly on the verge of collapse, rides a current of inherent stability. With flashes of sun rebounding from its flailing wings, the gull intrigues and entertains us.

## the broiler house

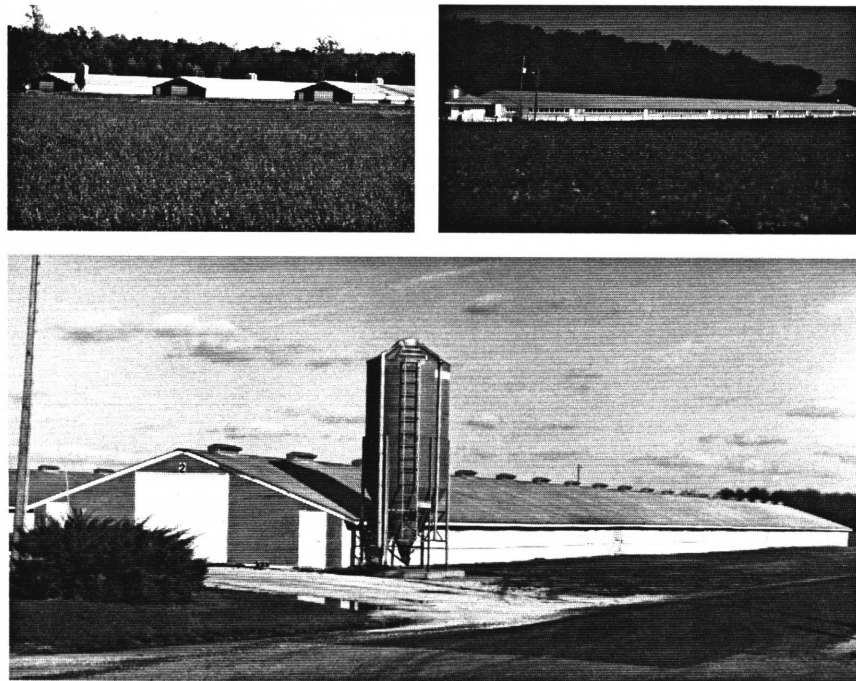

As a generator of forms for the research facility, the broiler house becomes a template for the laboratories. The ubiquitous broiler house of low linear steel is a Sussex County staple. Profoundly utilitarian, it is a highly vented extrusion limited only by the expanse of flat topography. Realized through the replication of autonomous structural frames, it optimizes productivity through the ease of unencumbered expanses. As a rectangular array or one single string, the broiler house is a permanent part of the local configuration.

## boardwalks



The boardwalk is a great commercial street; an eternal buffet table. As processional walks of fun, frolic, and sport, or great boulevards of solitude and reflection, it is an endearing mecca for the beach going masses.

## towers

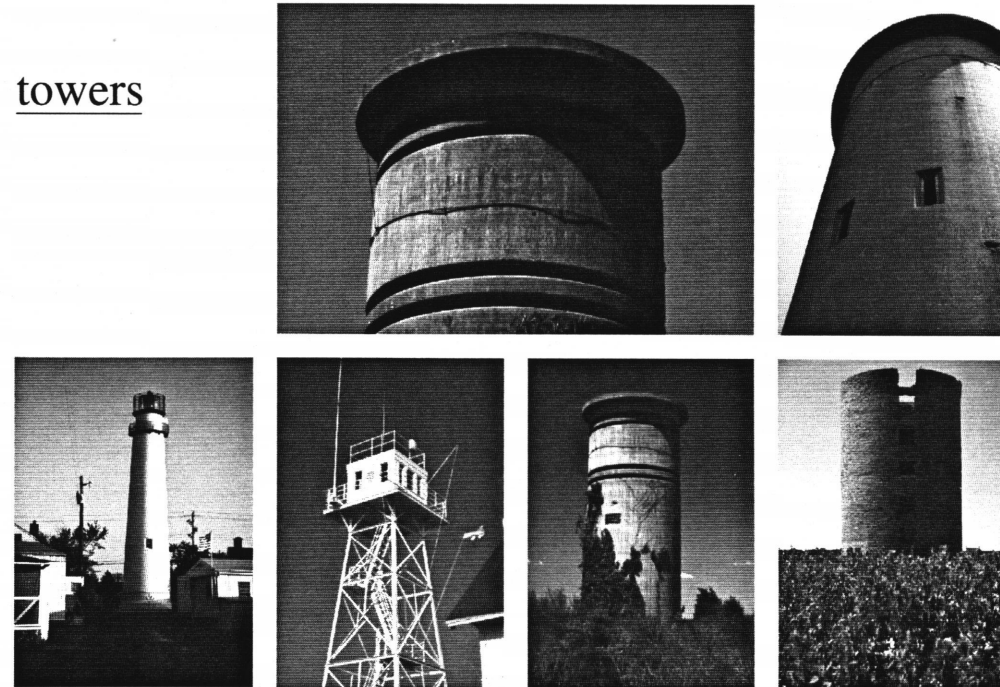

Remnants of wartime fear, mighty concrete cylinders space themselves along the coastline and stand a lonely vigil. Through narrow slits of observation, they monitor the panorama and provide a beacon; a conspicuous signal of location. In open landscapes or squeezed between encroaching development, they abdicate purpose but exude presence. In some cases, canvases for graffiti, the towers, nevertheless, endure. As powerful points of convergence, they are a remembrance of times past and certitude of a continued legacy.

material

*a unifying resource*

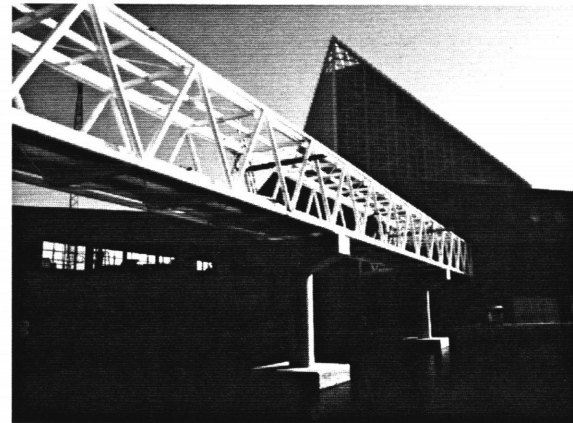
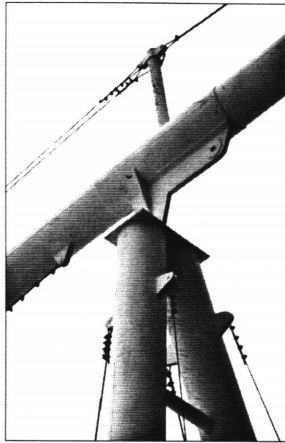

*"The metal possesses little art history.  
What associations it possesses are those  
of this century: power, structure, movement,  
progress, suspension."*

David Smith

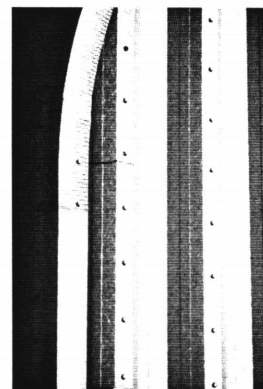
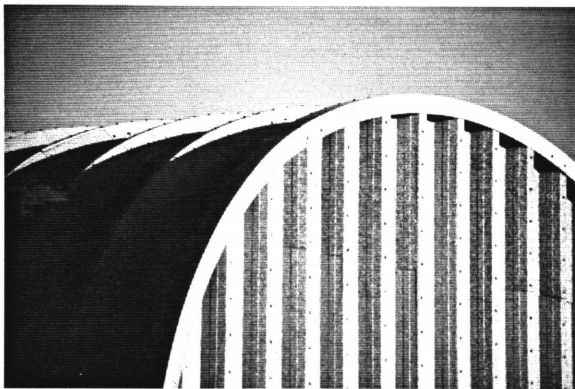
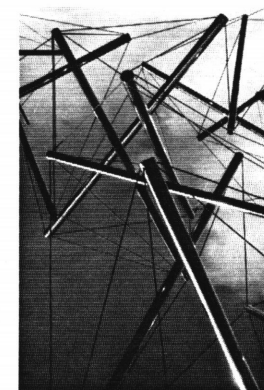
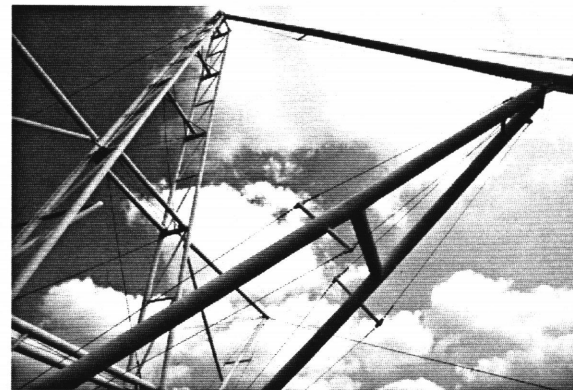

*repetition*  
*repetition*  
*repetition*

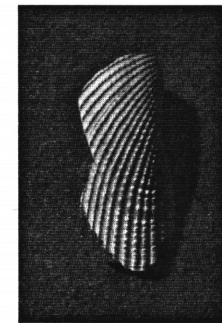
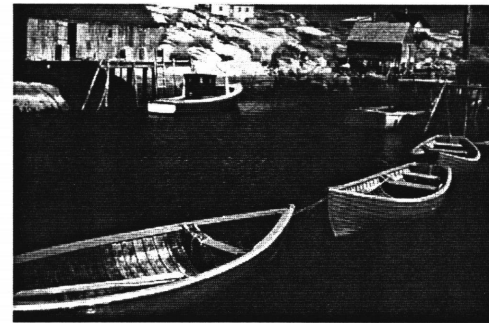
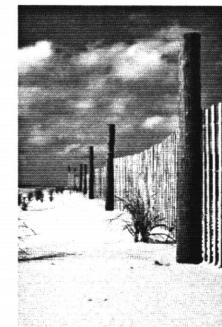
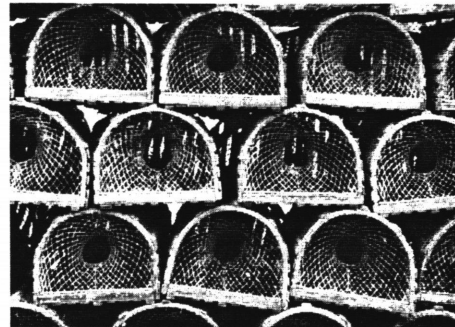
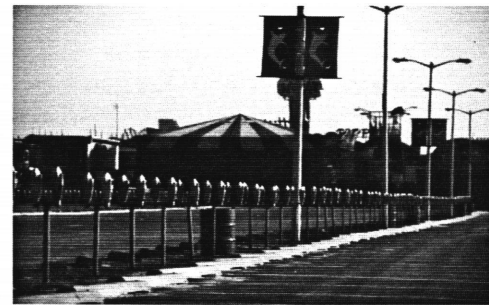
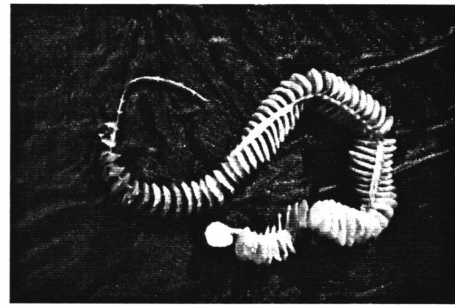

The repetition of objects in the marinescape is validation of the component aspect of the research facility. The reiterations that man and nature has displayed is confirmation of the intent. Whereas duplication of objects is no principle relegated to a specific location, in the context of an environment intimately bound to its necessity, it becomes a cause for celebration.



# sketches

*visual thought*



*Thoughts of design are first brought to fruition through the vehicle of sketching. As a loose interpretation of images or a more direct examination of detailing, the sketch is a fundamental platform.*

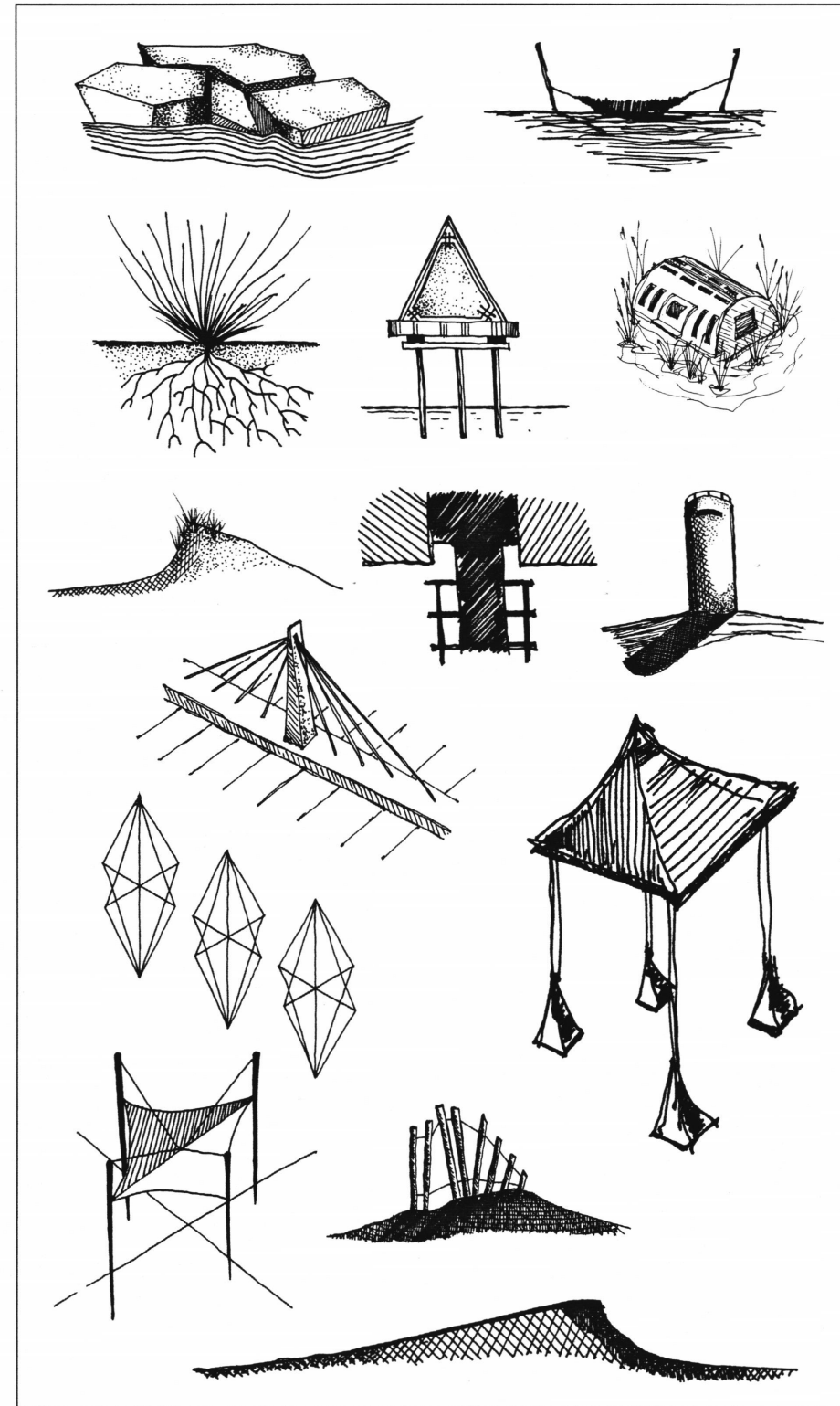
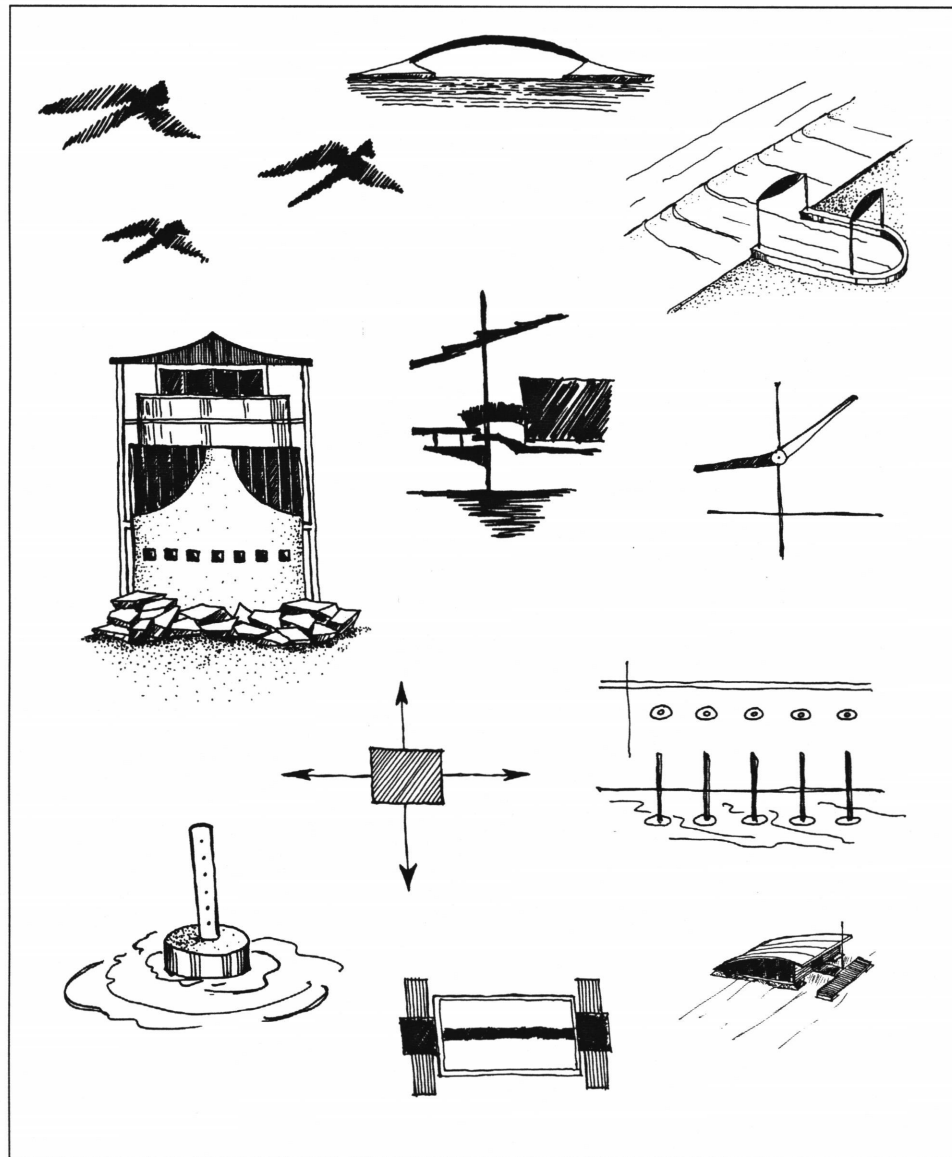

parts

*elements of the whole*

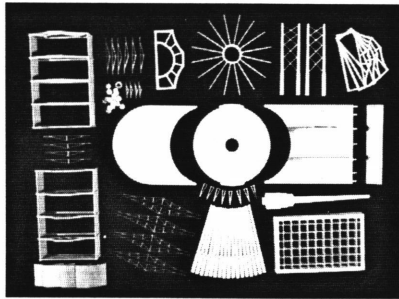

*The prefabrication of a myriad of parts to be subsequently assembled, advances an attitude about manufacturing, tolerances, and fit. The intricacies of manufacturing technology become salient concerns relative to the more liberating goals of design. Parts that are designed and manufactured to not only fit together, but to express form on a piece by piece, as well as an assembled basis, are integral "elements of the whole".*

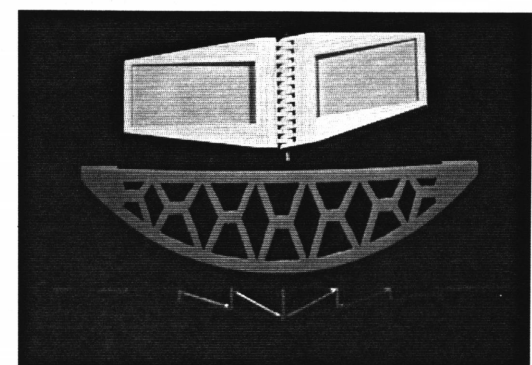
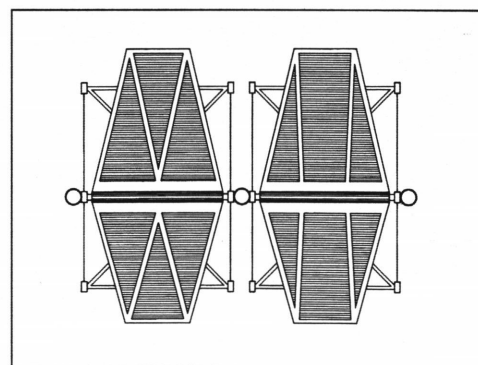
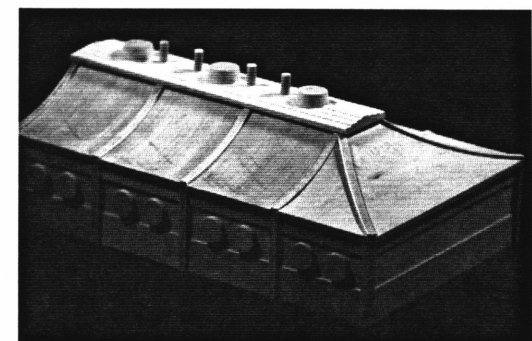
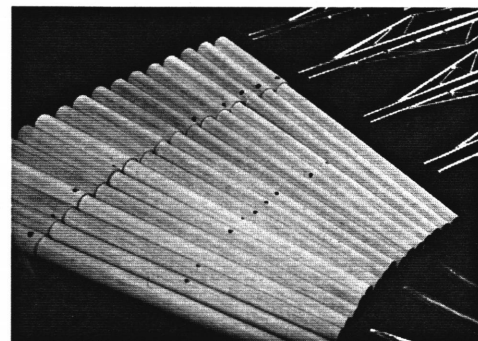
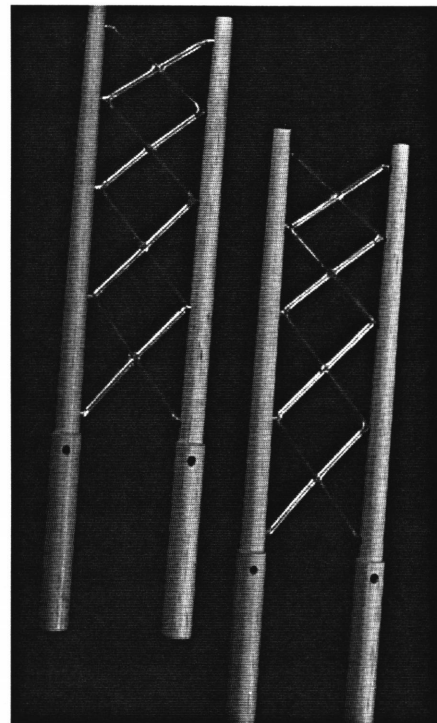
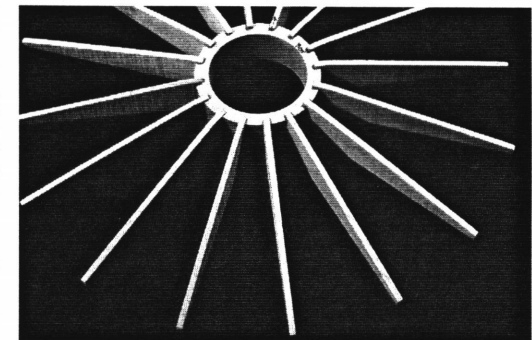
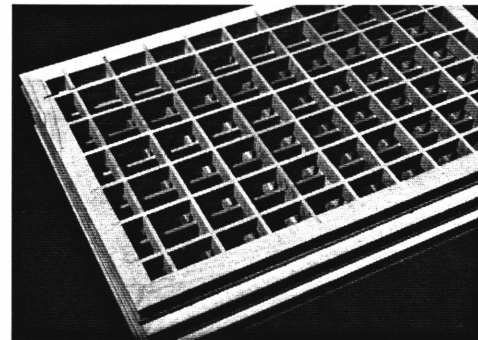
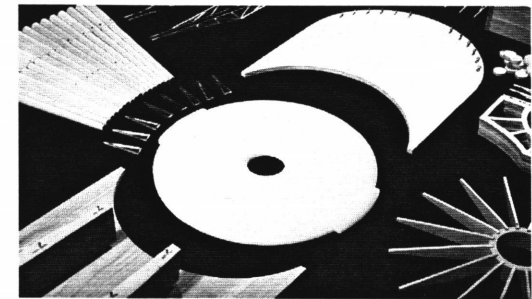
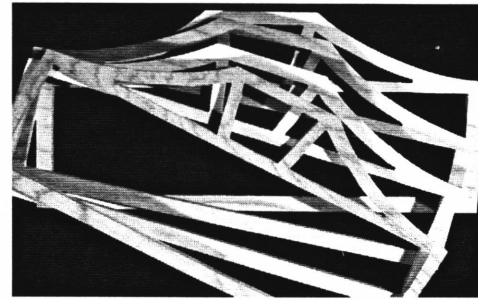

mast/pile

*a foundation*

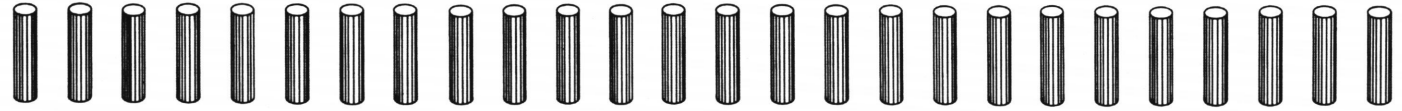
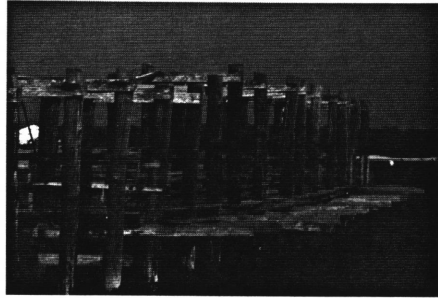

The Mast/Pile element is dominant. As a foundation upon which the remaining parts attach, it is the stage of a working drama. Unceremoniously driven into the muddy base below, they stand erect and launch the connection of a thousand things. From one location to another, spanning members connect and form the regulated orthogonal array called a foundation.

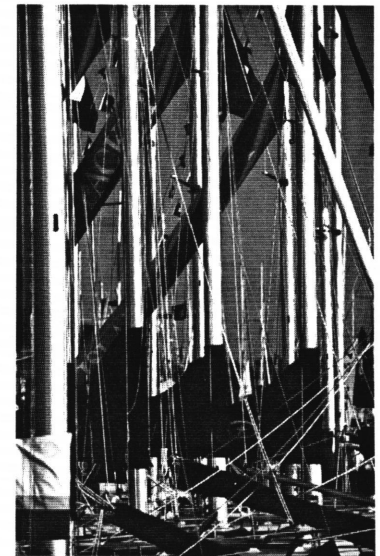
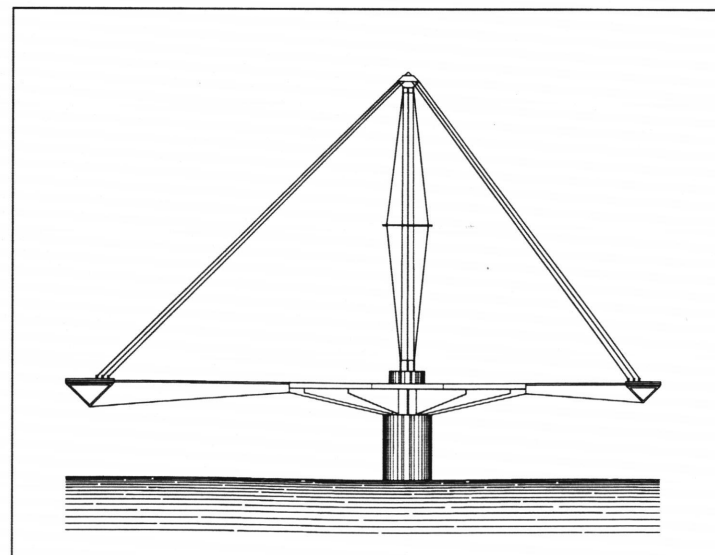
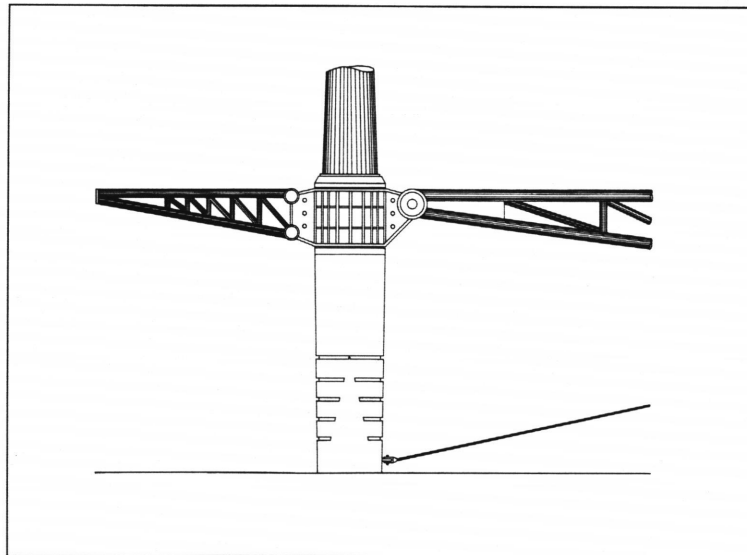
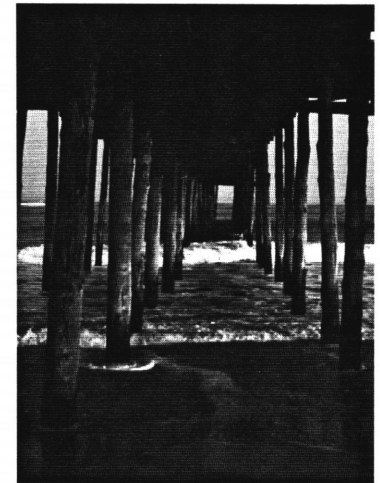
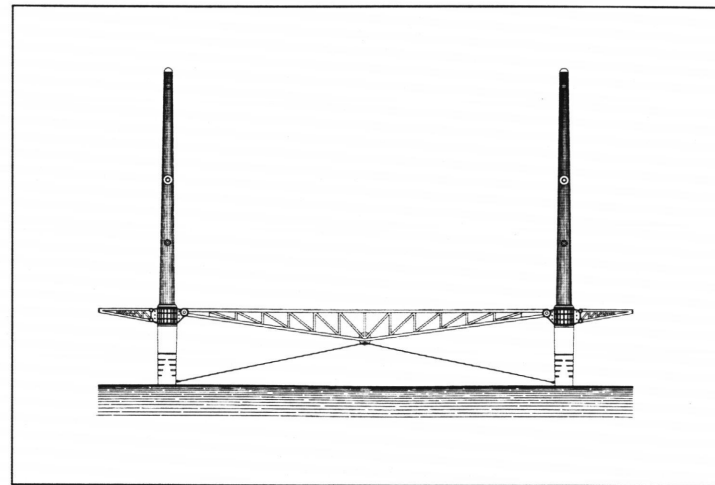

# details

*a technical search*

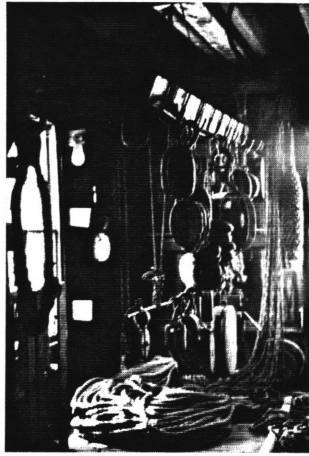

The translation from the imaginary to reality involves a necessary excursion into construction thinking and detailing. What may have seemed a simple elegant form to achieve may now demand the most scrupulous rendering of numerous details. An early attention to this critical aspect of any design will help preclude the often burdensome task of detailing after the fact. Only when conception and execution are addressed as complementary aspects will a design be fully integrated.

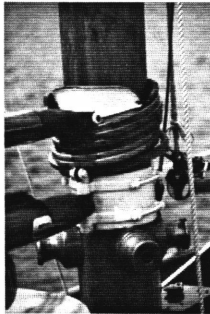

## Detail Key

1. Motorized Shading Device
2. Mast Connection
3. Truss Top Chord
4. Truss Connection to Mast/Piles
5. Extrusion for Laboratory Unit Frames
6. Hand Rail

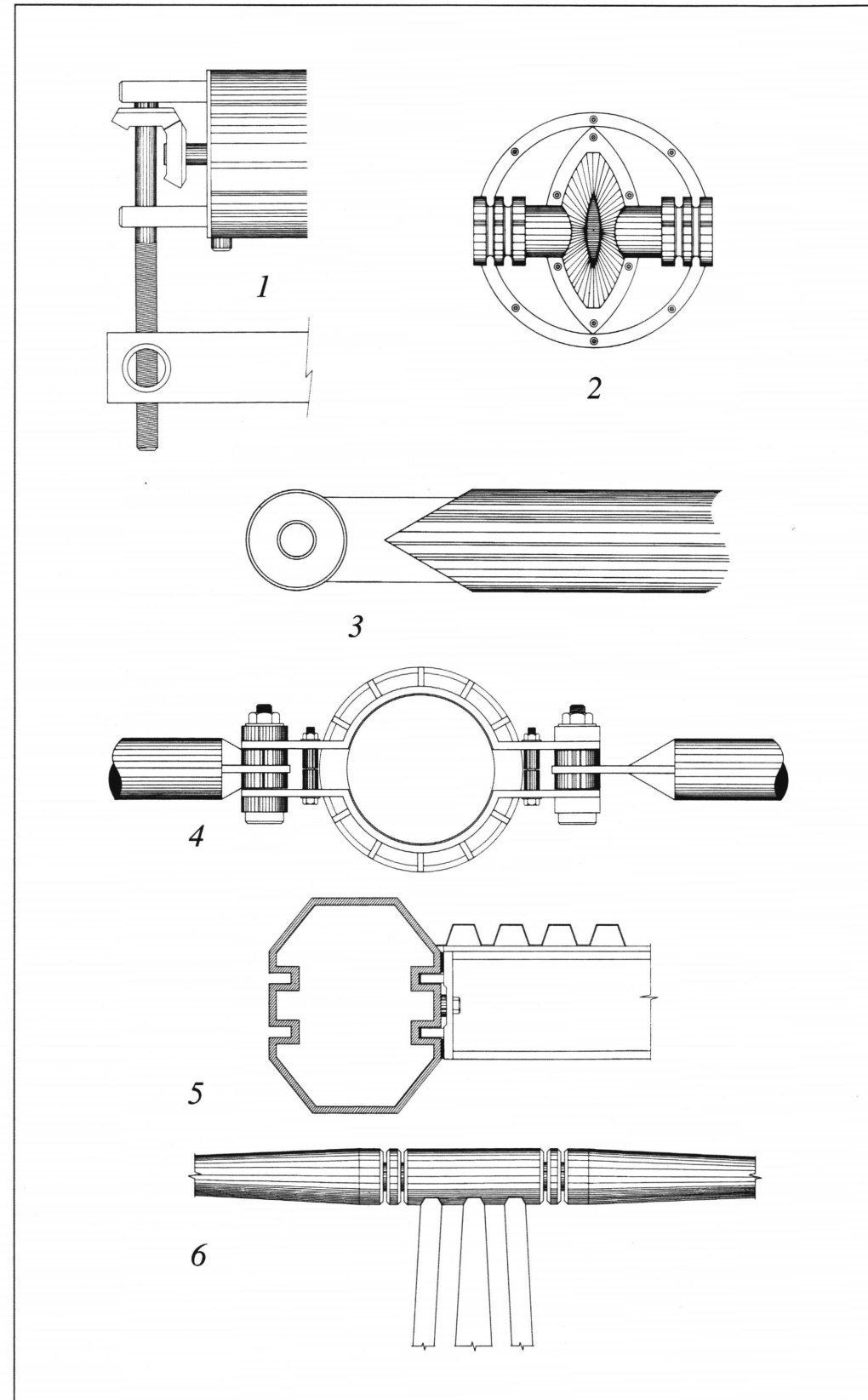

# Oceanographic Research Facility

*a solution set*

75° 4' 23" West Longitude, 38° 36' 38" North Latitude marks the center of the research facility. Although not the true physical center, it is a locus; a node of presence and the source from which the remaining parts of the whole flow. The communications tower abides at this location. Housing the accoutrements of weather forecasting and current communications technology, the tower oversees the facility and provides the primary link to the external world. The tower begins on four separate tapered concrete foundations set into the spillway of the tidal trough. From bolted-down baseplates, four column clusters containing four cross-reinforced steel pipe columns extend and engage a large circular space frame above. The connection is realized by a specialized steel part. A concrete disk centrally pierced by a steel spindle sits on and cantilevers beyond the boundaries of the space frame. A cylinder defined by an array of smaller columns with glass infill encloses the house of communications. A tapered extension of the steel spindle, stabilized by cable stays, provides the roof structure and crowns the enclosure. Entrance to the tower is gained by way of an upwardly spiralling suspended ramp originating from stepping blocks set into the tidal trough spillway.

The tidal trough spillway is the culminating place of the flanking tidal troughs. Circular in plan, it is an intersection of streets, both pedestrian and water. At high tide, the spillway floods with water and defines the pedestrian street in terms of a series of spaced stepping blocks that promote the full flow of water. The tidal troughs connect the open Indian River Bay with Balder's Pond at the spillway location. They are the purveyors of tidal information. The troughs demonstrate the X and Y components of tidal action. The trough leading from the bay side is a long, gradual concrete incline. As the tide moves to high, it reflects the forward horizontal flow of water often described in the expression "the tide is coming in." The pond side trough is a series of steps in increments of one-half foot. As the tide comes, in the steps are filled one by one in increasing order of elevation and thereby reveal the upward vertical sense of tide. The troughs and spillway interact as a unit and with water as its hour glass becomes a natural time piece.

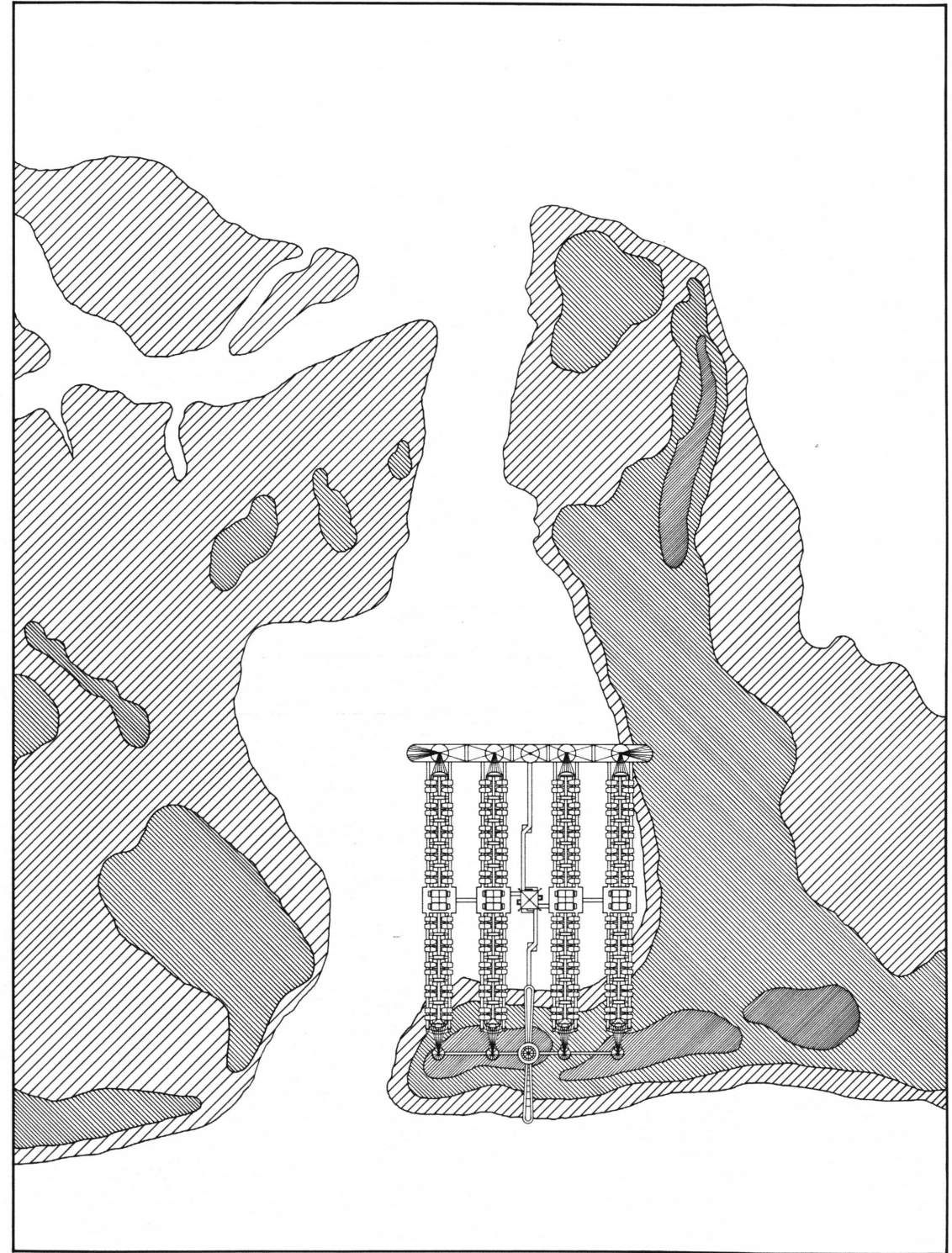



Wooden walkways connect the communications complex with four plazas. The plazas are large concrete discs that recall their usage from the communications tower disc. At the center of each plaza is a mooring mast fixed in place by struts and cable stays that constitutes the land-based connection for the laboratory strings. The mooring posts are points of great structural resolution and, in deference to their power, warrant development into a place. The resulting plazas not only channel pedestrian traffic towards the laboratories, but provide a respite, an intermission, a locus for lingering.

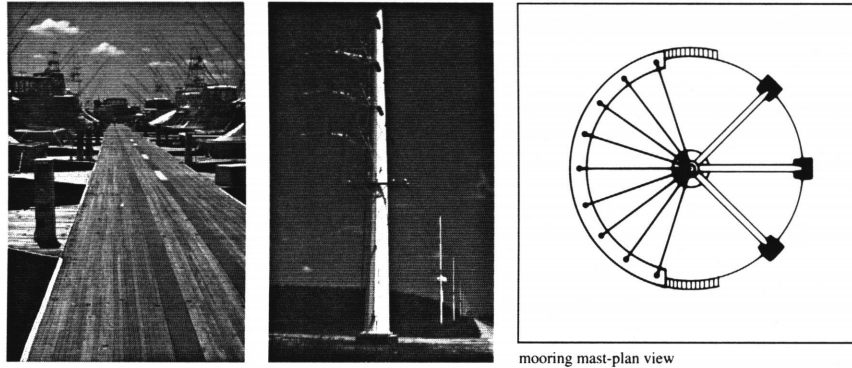

From the top of the mooring masts of each plaza, steel cable mooring lines fan out and connect to a curved steel truss. The truss redirects the tension forces of the mooring lines to a pair of cross-braced masts at the supporting ends of the truss. An orderly arrangement of piles with socket-integrated masts defines each side of the laboratory strings. Structural continuity is maintained by steel cable cross bracing the length of the string.

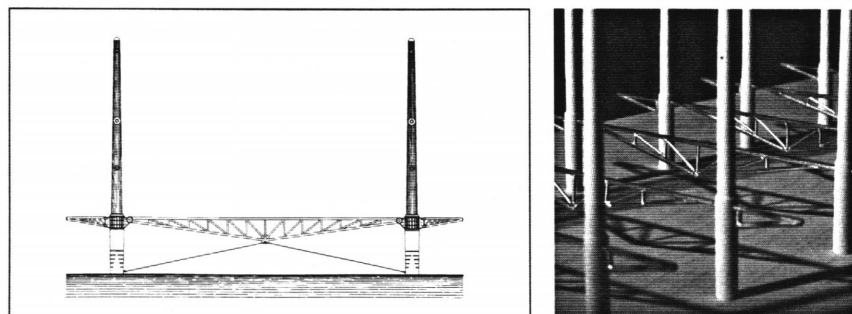

Each pile/mast arrangement is connected to a duplicate arrangement on the opposing side of the lab string by way of a tubular steel fish belly truss. The mast/pile configuration is central to the project and assumes multiple roles in the full structural scheme. Its connection with the fish belly truss provides the support system for the laboratory units. Opposing this connection, a support bracket fastens a cantilevered tubular steel truss that supports the walkways that flank the string of laboratories. Lastly the masts engage the wings.

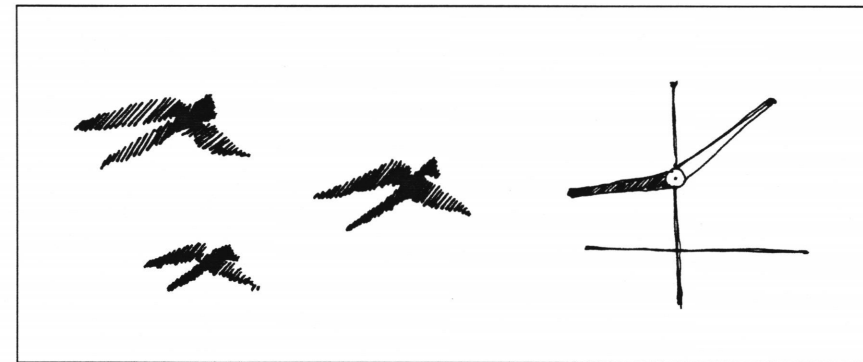

An abstraction of the gull, the wings are modifiers of light and air. Fashioned as a tubular steel frame with fabric panels, each wing is a functioning mechanical device. Equipped with a system of gears and pulleys, the wings can shade or expose, capture or deflect the natural elements. At varying times the wings may become mere structural skeletons that allow for the full penetration of the sun; or with their sails unfurled, they may direct the low winter sun down into the laboratories. At high noon in the summertime, the wings stretch out over the labs and walkways providing shade and casting rhythmic patterns of light and dark that echo the repetition of the natural surround.

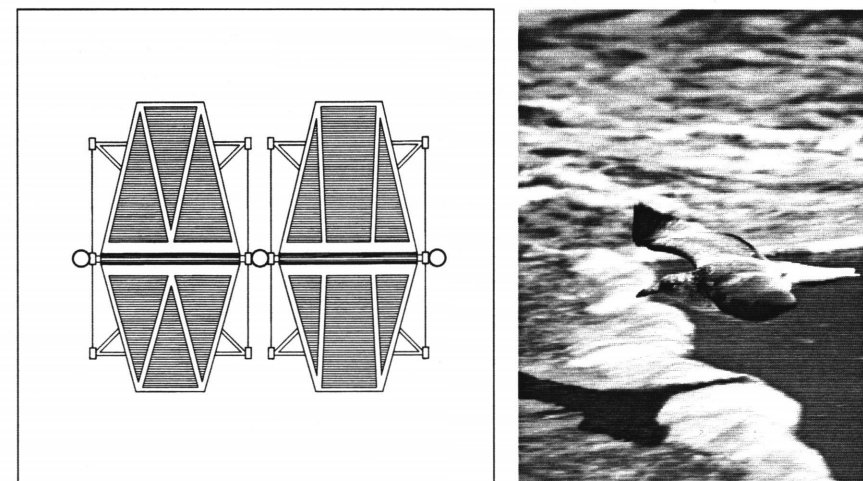

The laboratory string is likened to an end to end string of boats or barges. Each unit in the string is a self-contained module undifferentiated from the remaining modules excepting the internal arrangement of fixtures and furniture defined by its users. For the greatest degree of adaptability and flexibility, an uninterrupted space becomes the schematic of choice.

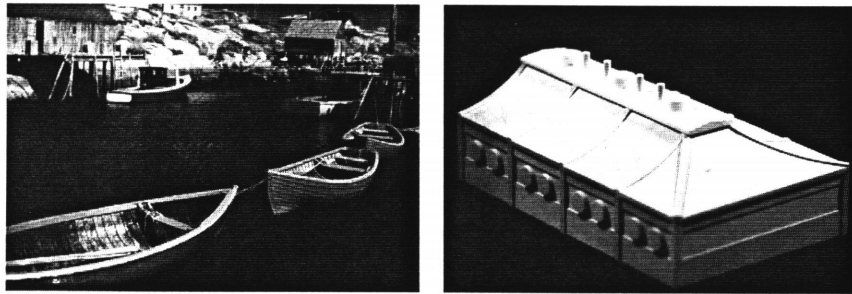

The units recognize three distinct zones. The first zone is a structural and mechanical one. A grid of beams in an egg-crate arrangement provides the primary structure. The egg crate functions as a chassis. The beams are punctuated along their length with holes that serve to reduce the overall weight and provide the pathways for the delivery of mechanical services. The user zone is a simple rectangular box defined by a linear arrangement of trussed frames connected by intermediate purlins with metal cladding. Within the trussed frame the third zone is realized. Utilizing top and bottom chords and web members, a mechanical zone dedicated to ventilation and top lighting is accomplished. The notion of servant and served spaces as explored in the work of Louis Kahn becomes apparent. Lab units are connected to each other by a glass room. An arrangement of nested curved glass panels on hydraulically operated tracks serve as doors. The glass room conveys lights between the units and confirms the natural exchange between building and site. The nondescript lab units, unchanging in their sense of uniformity, become the vessels for scientific inquiry and change.

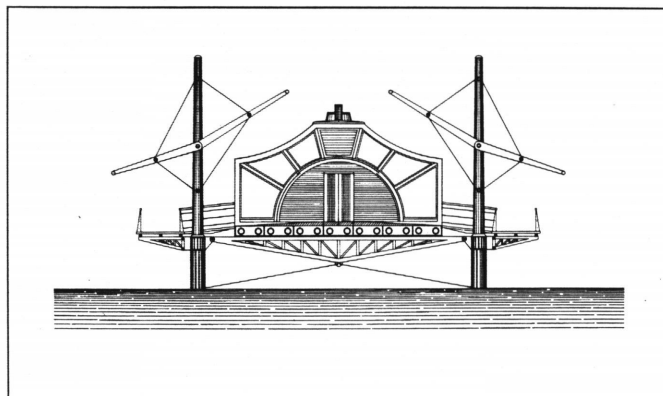

At the remaining end of the lab string, forces are channeled to another mooring mast by the same arrangement of curved truss and cross braced pile/mast used at the beginning. Similarly, the mooring mast occupies the center of a large concrete disc. In concert, they constitute the water-based connection. Five circular plazas are held above the water on cantilevered beams emanating from the shafts of the mooring masts. Five circular plazas and their mooring masts, define the structure of the dock. Steel frames supporting bolted heavy wooden planking are hung by cables from the tops of mooring masts and describe the plaza infill. Borrowing its form from cable stayed bridges and sailing ships, the dock is a place of dispatch. It is the loading platform for ocean-going science.

The true physical center of the facility is the open air pavilion. Wooden walkways from the labs, dock, and communications tower converge there. It is a large hovering platform shrouded by a taut fabric skin stretched on a steel frame. It is a special place of gathering. It accommodates a range of congregation. The main platform is large and open and suitable for the arrangement of chairs and tables a large group might require. On two sides, small depressed plane decks with perimeter seating recall the cockpit of a sailboat and lend intimacy to a small gathering of one, two, or three. From the remaining two sides of the main platform, ramps lead to small floating docks that offer a direct encounter with the water. Single seats and short benches complete the range of experience at the pavilion.

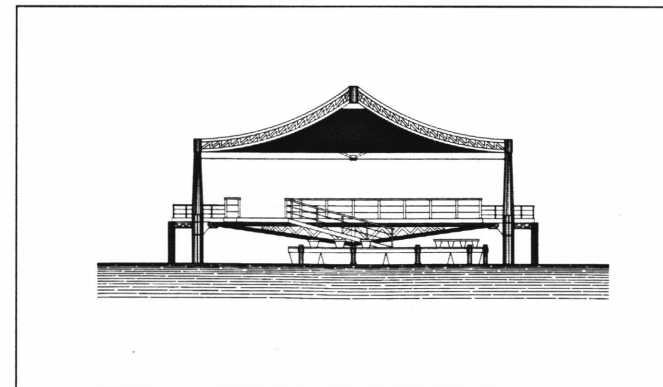

Besides the commonality of material, it is the walkways, the repetitious wooden boardwalks, that unify the facility. As conveyors of people, they provide the physical access to the parts. As paths set amidst the qualities of nature, they facilitate reflection and stimulate reverie. From the boardwalks one can travel above the water or go down to the water's edge. By walking the path around the tidal troughs, the experience of the tides can be better understood. By walking along the long shaded boulevards that flank the laboratories, one can sense the connection of this construction to this place.



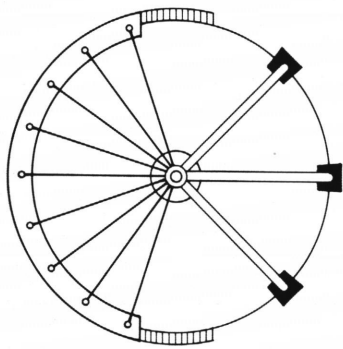

*Land-based mooring mast connection*

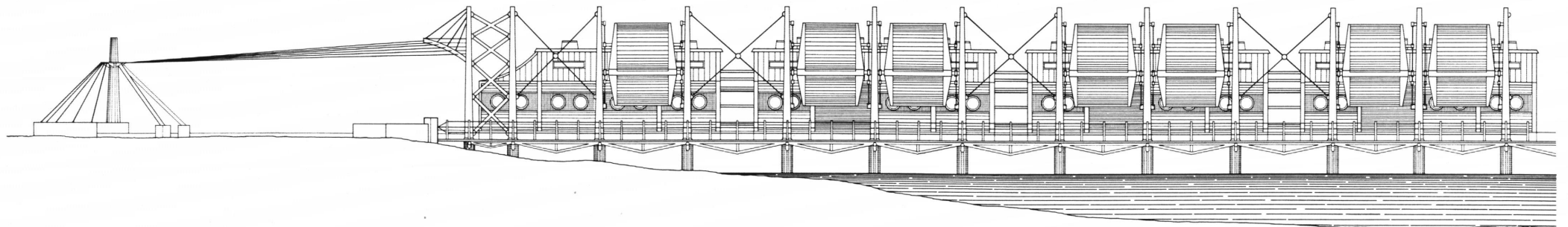

*Laboratory string elevation view - center section*

A fundamental laboratory unit assumes an additional role as a common administrative location. By retaining dimensional and material precedents, it appropriately occupies a link in the laboratory chain.

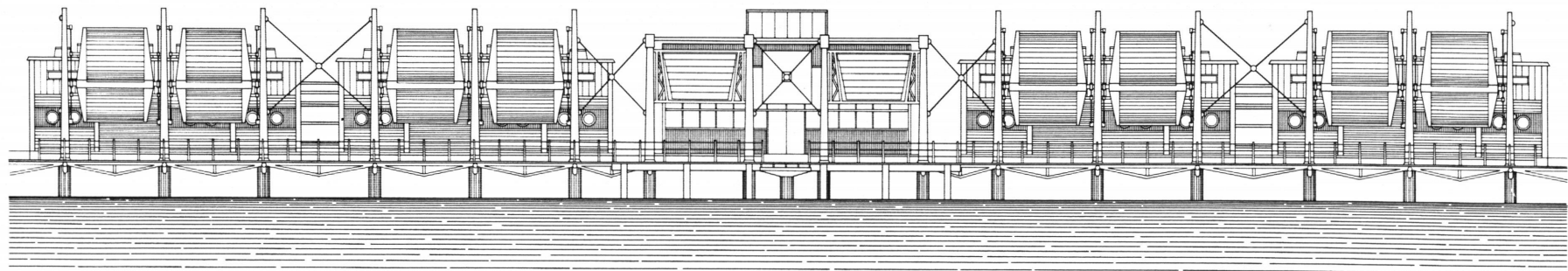

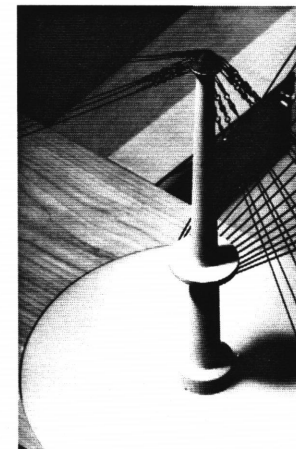
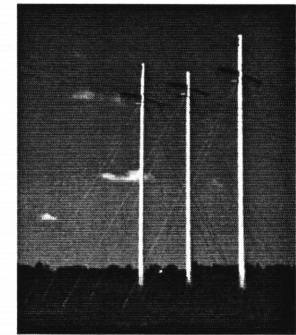

*Water-based mooring mast is a connection to the dock*

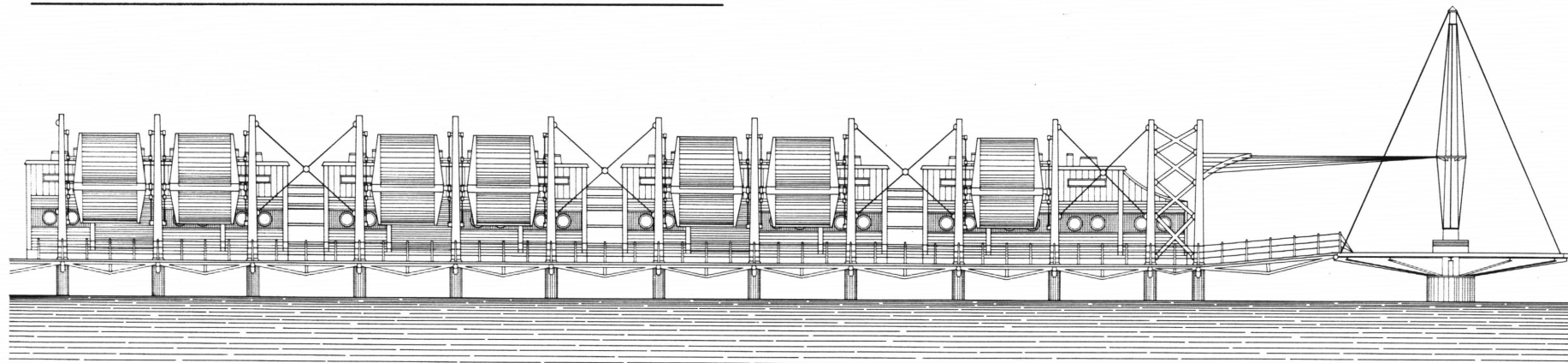

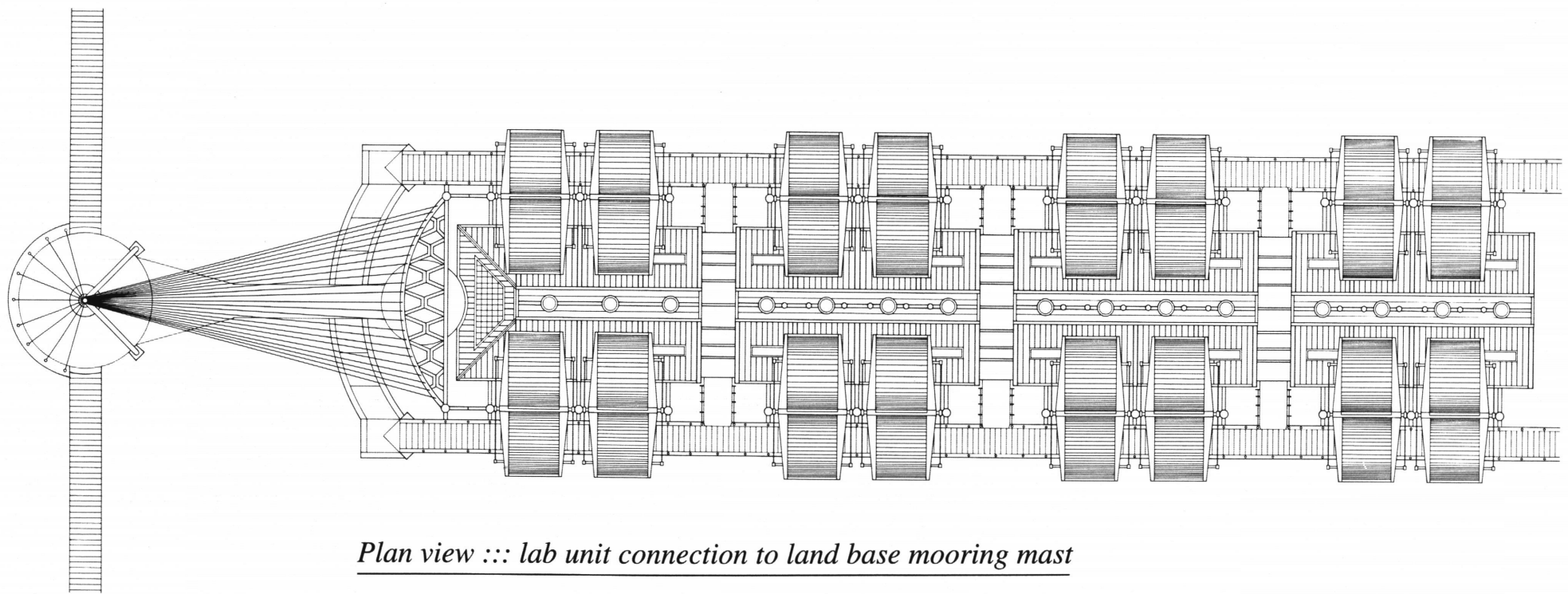

Plan view ::: lab unit connection to land base mooring mast

laboratory units ::: plan view center section

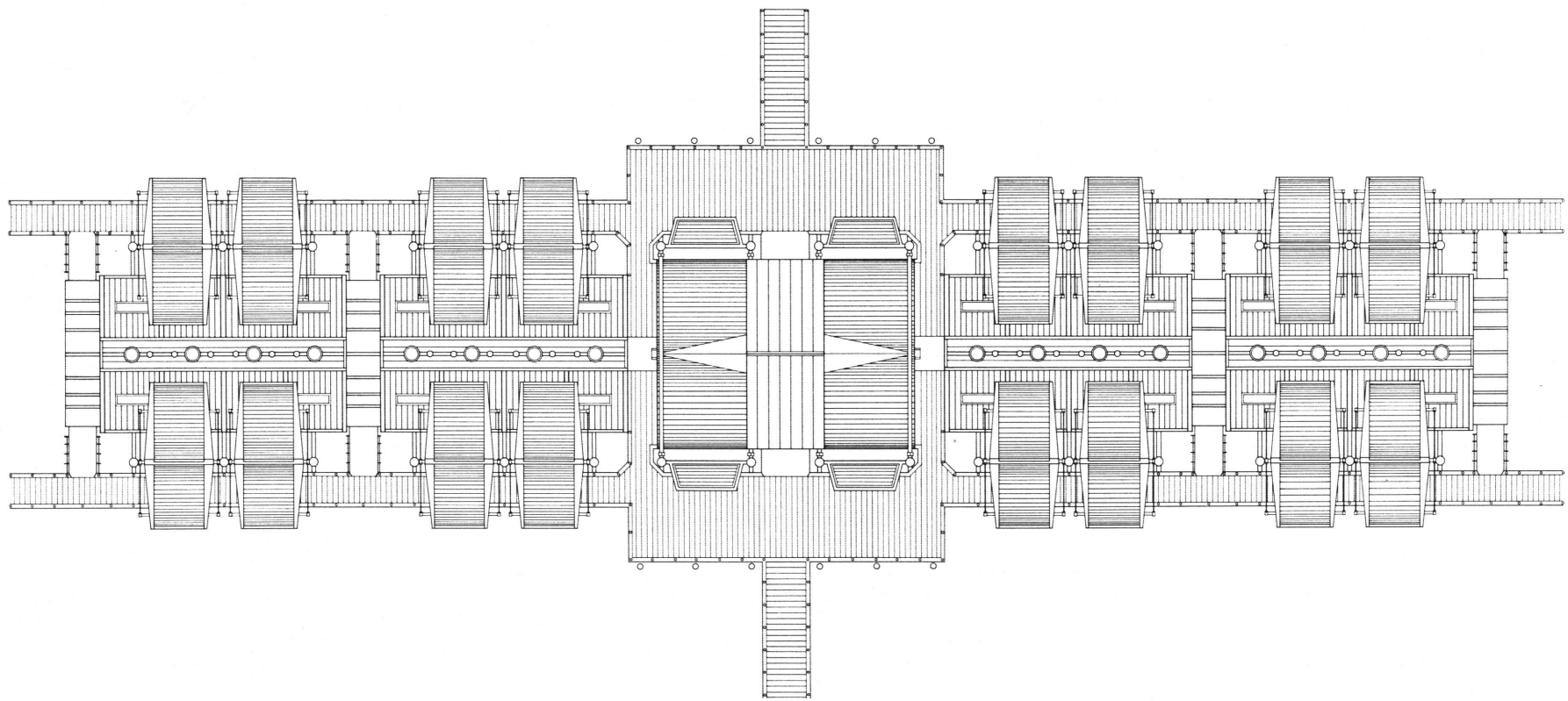



plan view ::: lab units and dock connection

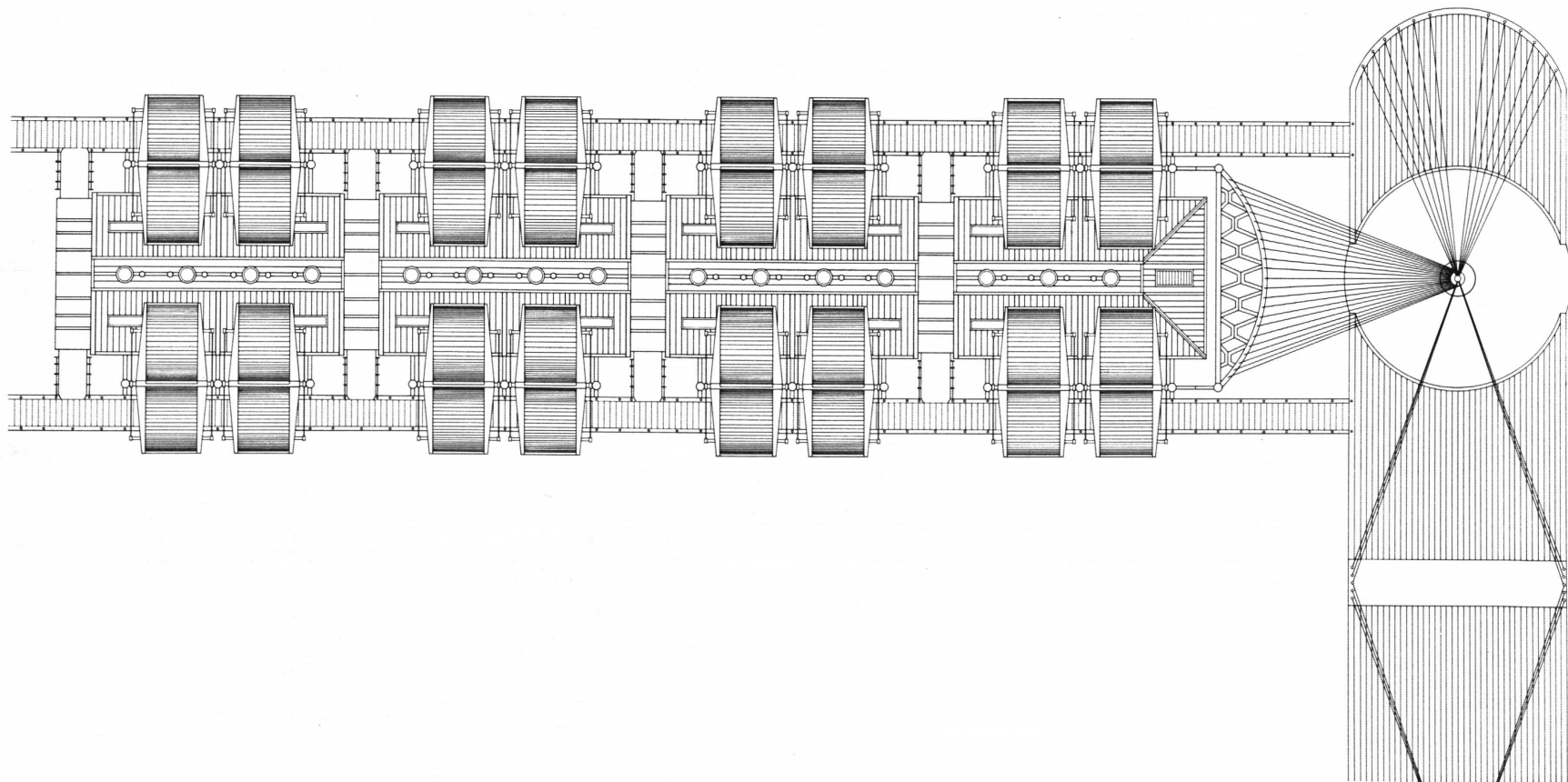
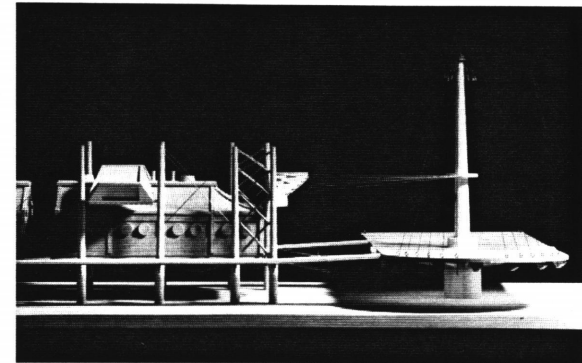

laboratory string

*a repetition of one block upon another*

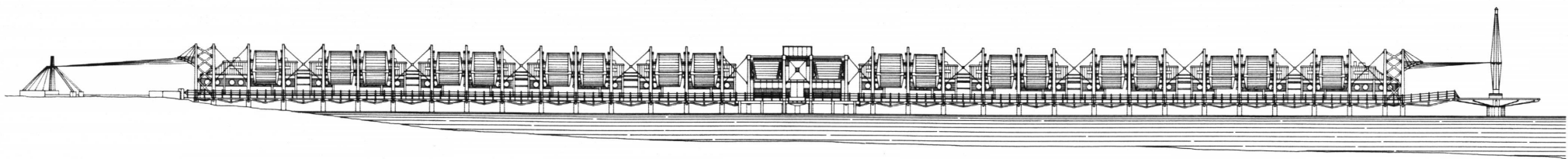
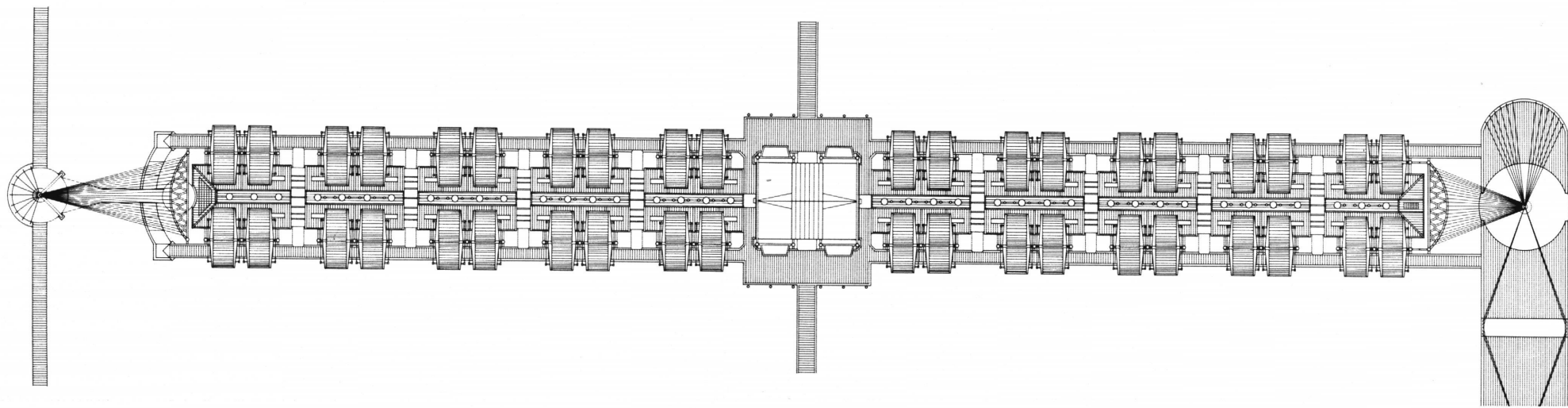

lab section  
*a unit in a frame*

*The laboratory is a unit in a frame. Enclosed by the sheltering wings above and the trussed system below, it is a seed in a structural pod.*

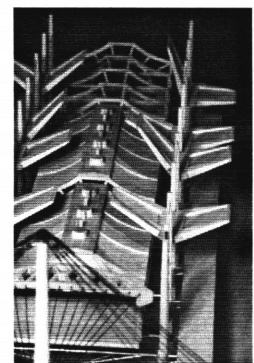
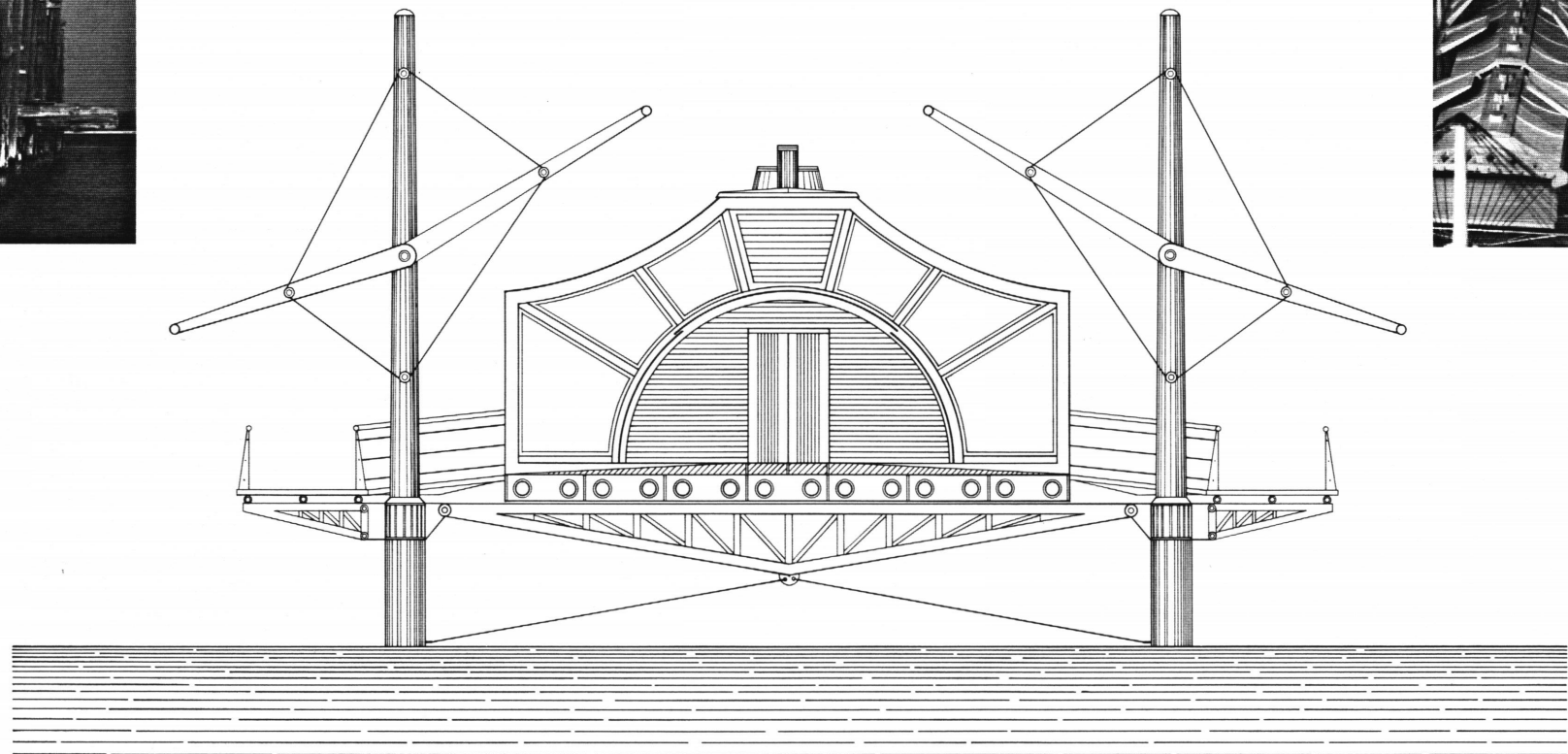
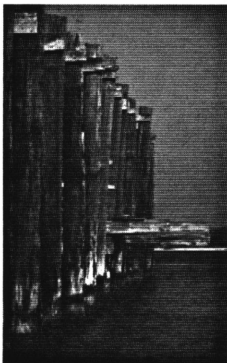
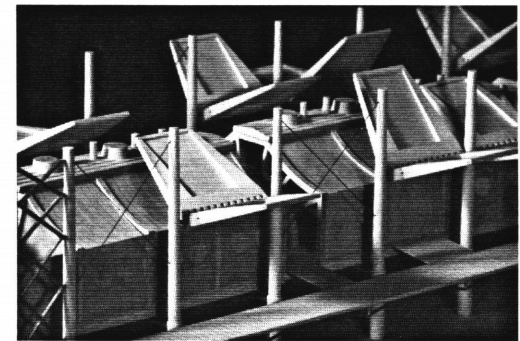
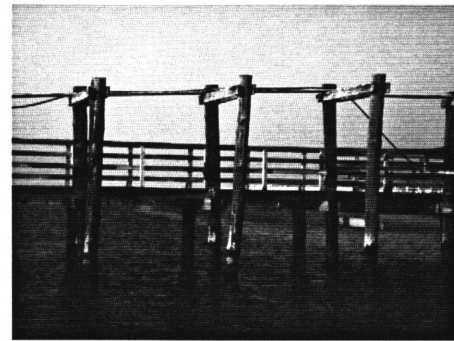
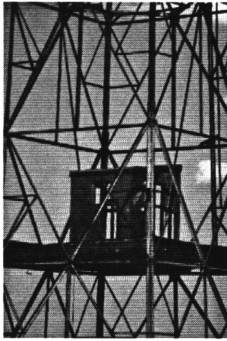

lab units  
*a prototype*

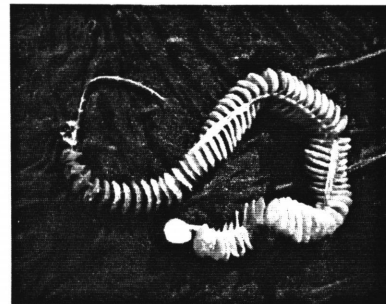

*The search for a laboratory form resides in the observance of unit type structures present in the marine environment. The biological configuration of skate egg casings and the linear lashing together of small unit skiffs encourage a solution expressive of the two.*

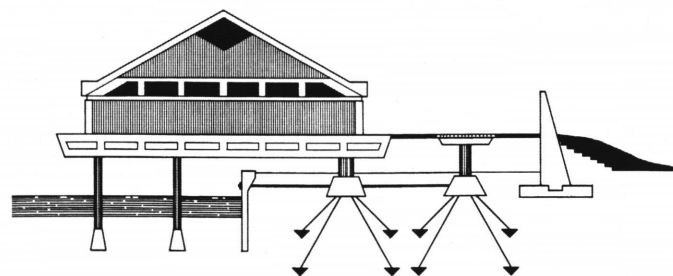
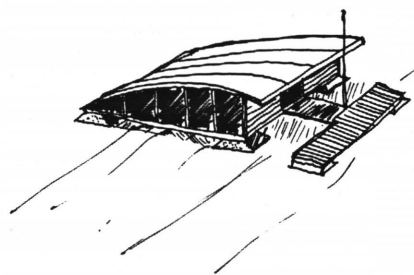
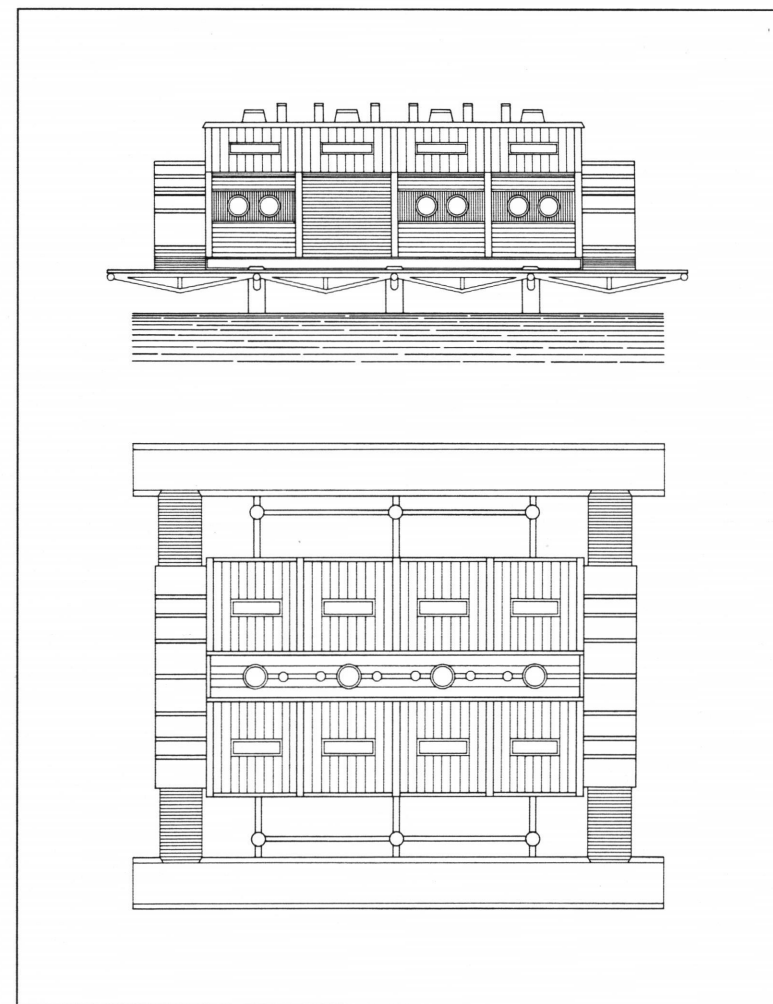
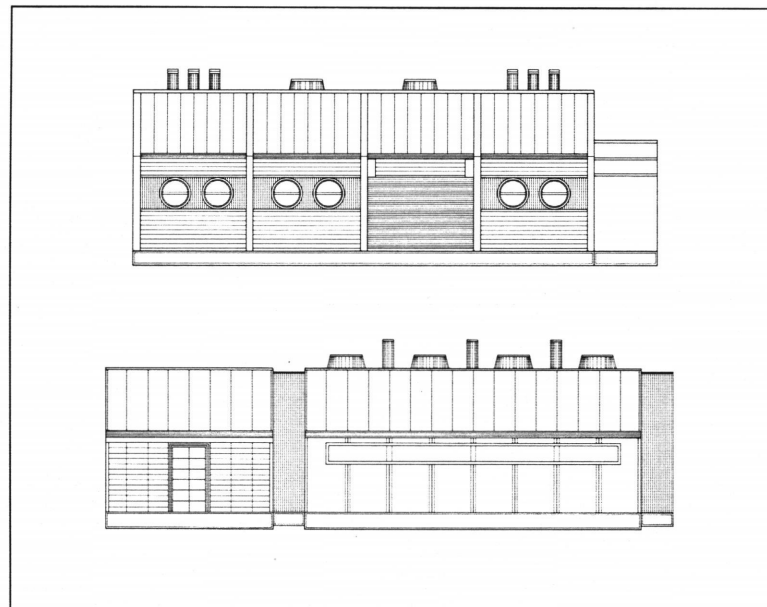
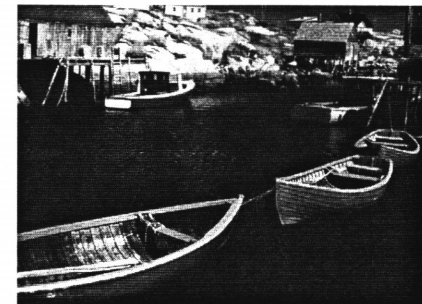

# a pavilion

*taut fabric skin*

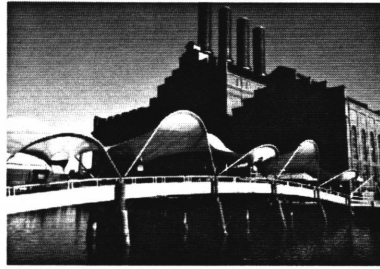

*The centrally located pavilion is an open air sheltered platform. Testing the forces of tension it participates in nature's exercise. As a gathering place it invites contact with the environmental skin.*

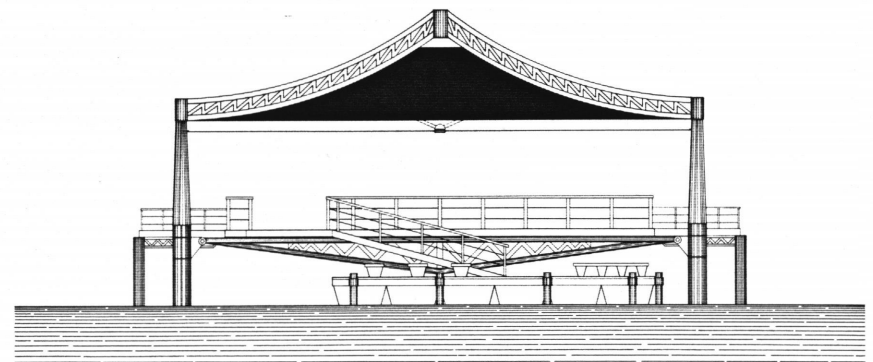
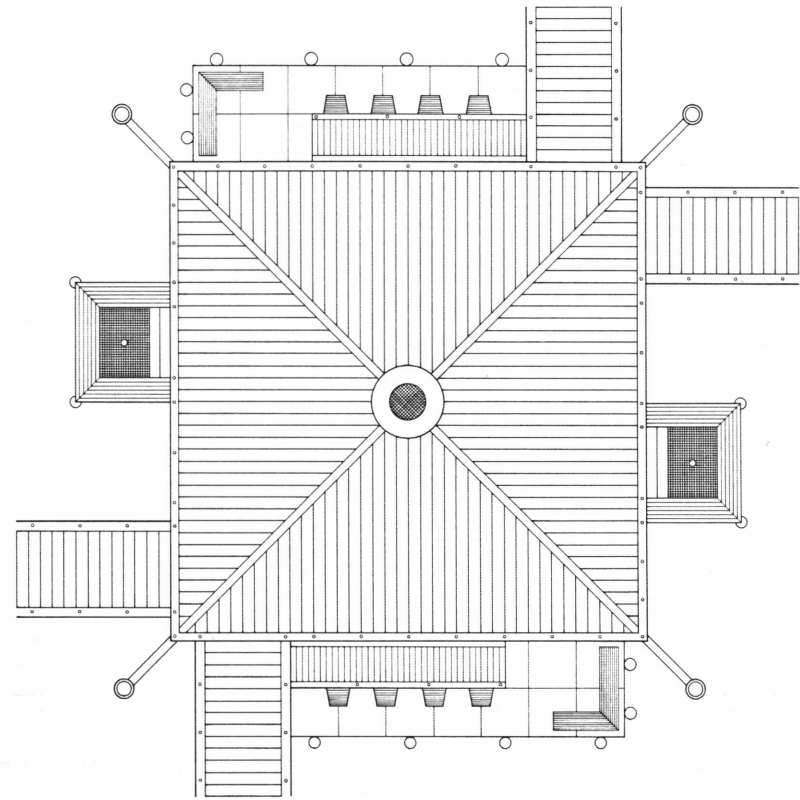
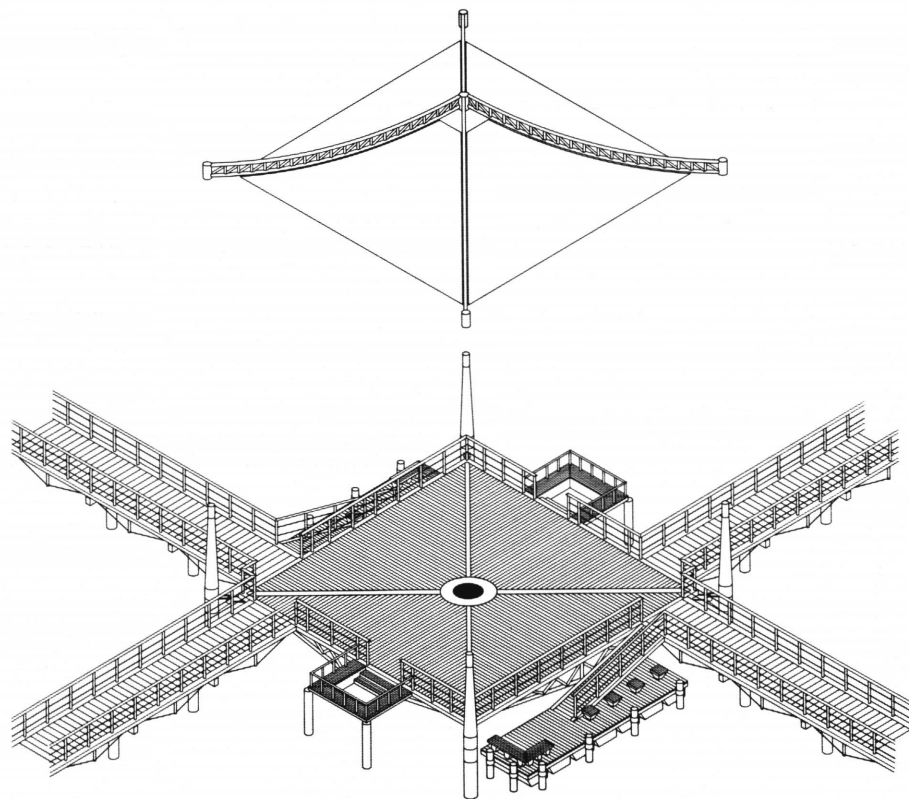

a tower

*a natural vigilance*

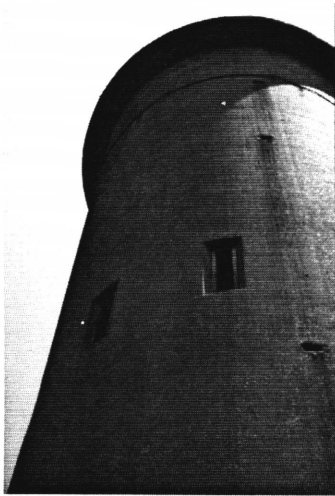

*The communication tower enjoys the full panorama of the site. From its vantage point it directs the full activities of the research facility. As a physical landmark it commands the attention of the casual passerby as well as the dependent gaze of the working mariner.*

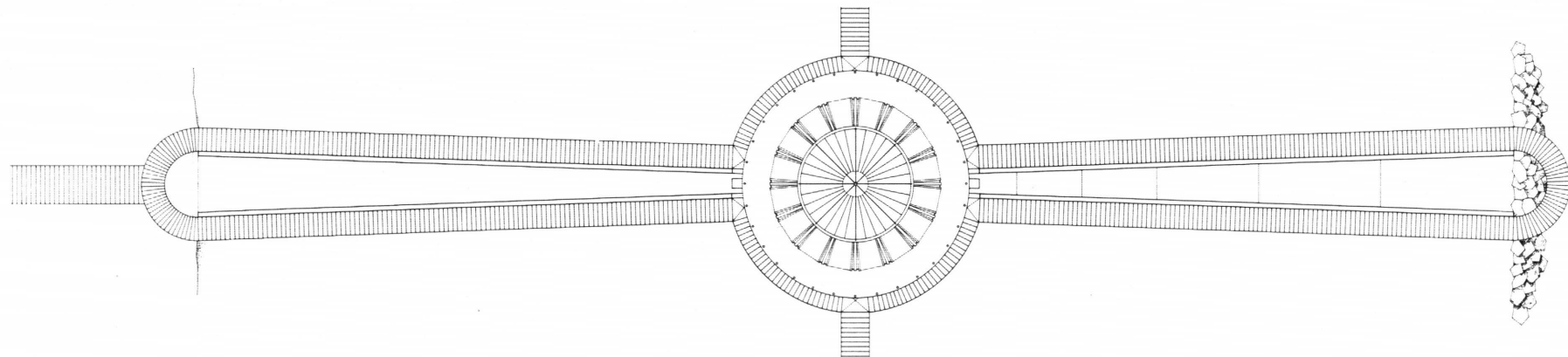
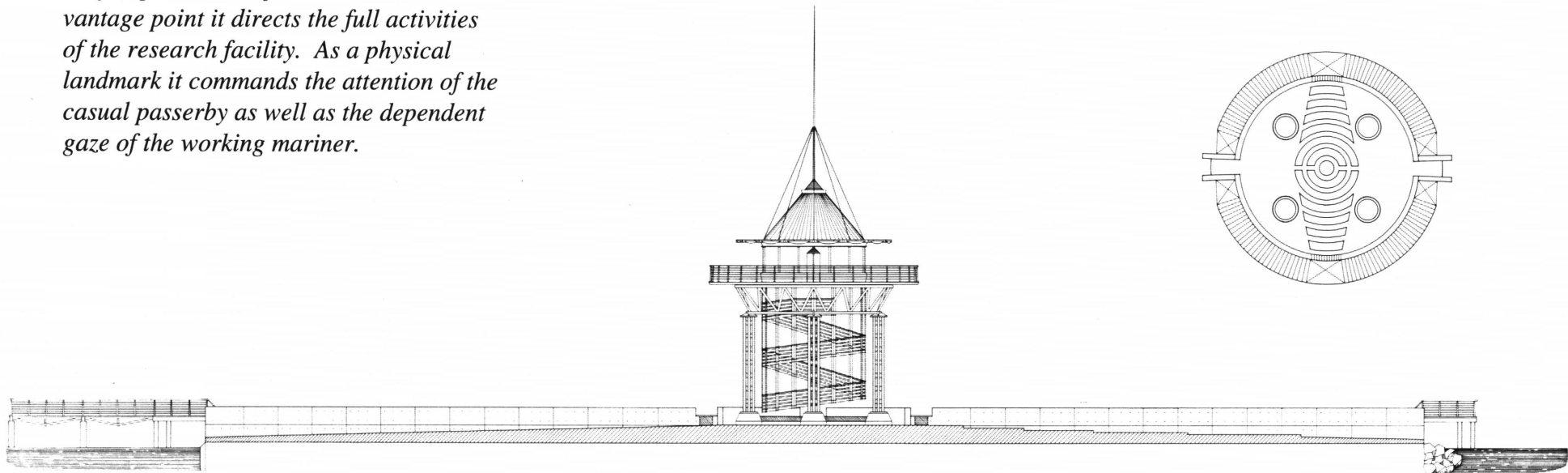
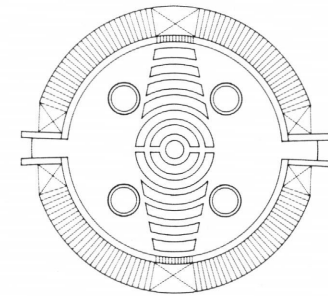
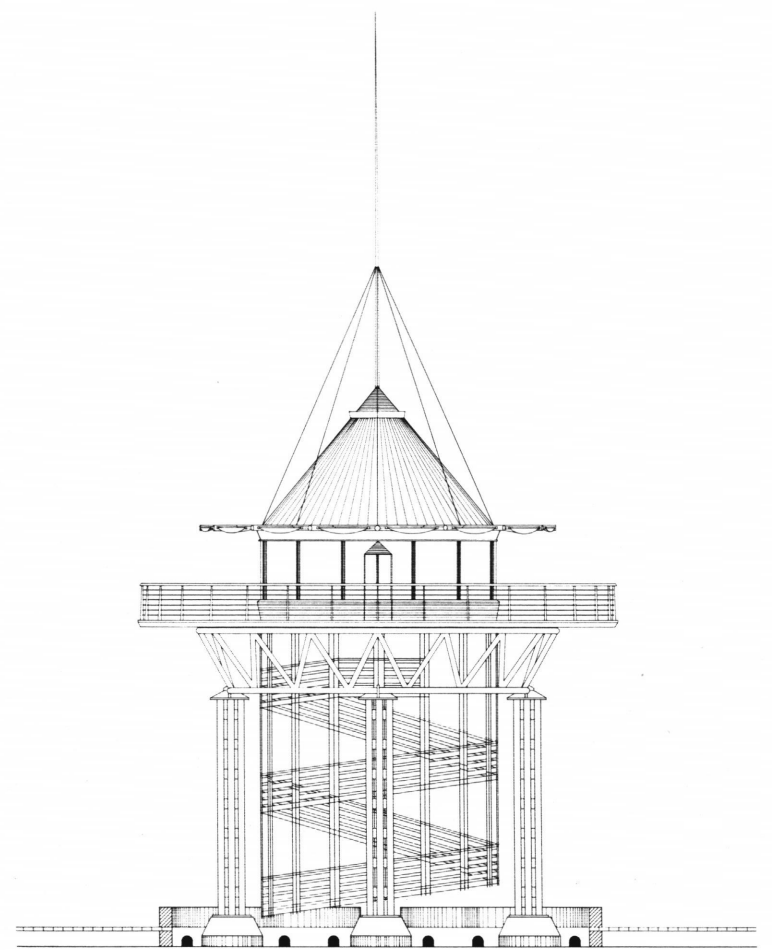
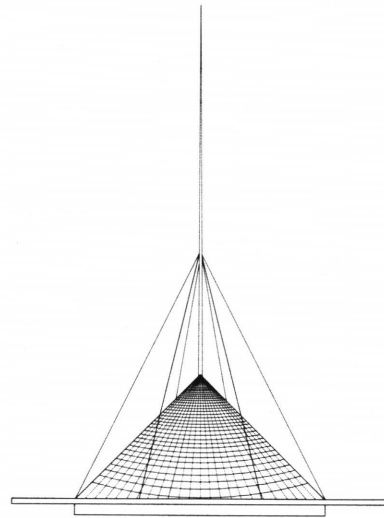

a dock

*an avenue of activity*

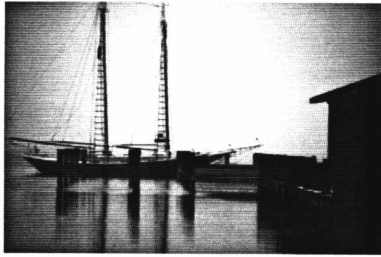

*The bustling activity of the dockside is a sensory feast of experience. Spider web trails of mast stays and mooring lines float against a chaotic profusion of bows, booms, and beams; creosoted piles, short and tall; street-like arrays of ramps and walks; and a veritable menagerie of maritime paraphernalia. The wooden walkways are untuned xylophones played by rickety wheel barrels and shuffling shoes that beat a tympanic cadence echoed from the hollow chamber below. A cacophony of chugging diesel motors and shrill bird talk rounds out the acoustic palette. The most salient, and surely most nostalgic, is subtle in effect. A fragrant blend of moist saltiness and sweet foulness is a visceral caress that consummates the experience and transforms the yearning. The dock and its simple activity become a rendition of what is delicious in life.*

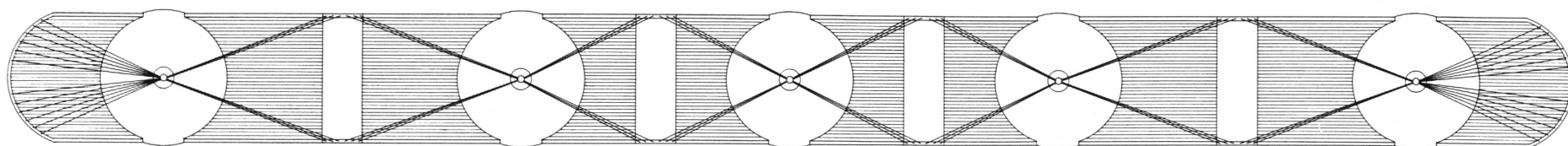
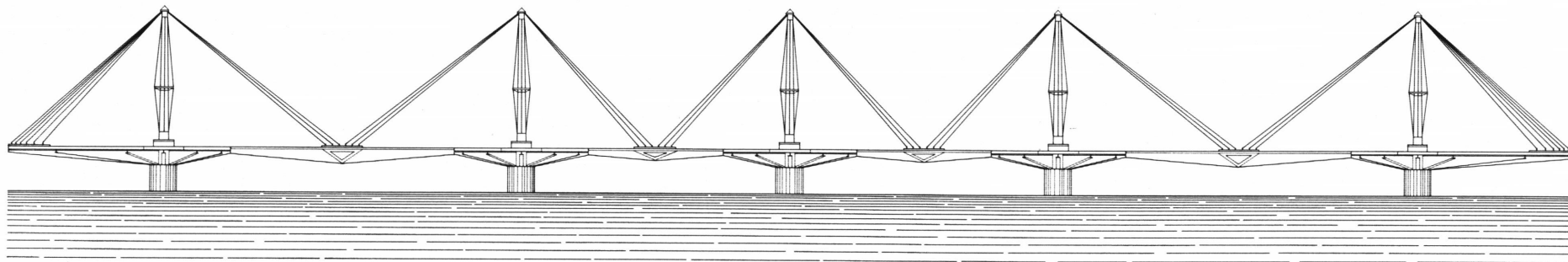
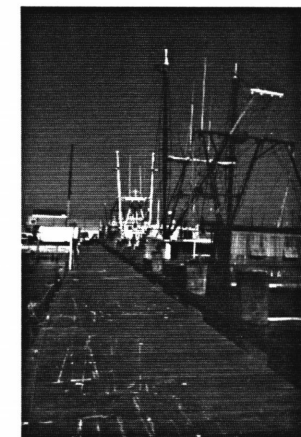
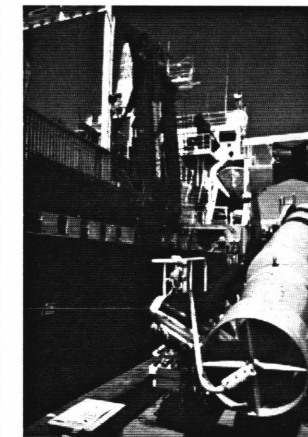
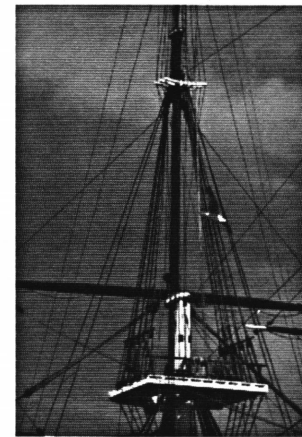

## construction

### *a building sequence*



*Stone groins, seaward bound; a slow deliberate construction of one block upon another*

As a kit of parts or a monolithic extravaganza, construction projects are realized through executable repeatability. A single event or action multiplied slowly and deliberately, building upon itself, ultimately manifests a totality. A single pile begins the sequence. Its method and location become a benchmark to which the ensuing piles reference. A collection of piles, orderly in formation, presents a foundation upon which another repeatable sequence is launched. Masts on piles joined by trusses upon which chassis with connected frames attach, is just a minor script in a major tour de force of construction. Each sequence exists as precognition with a priori knowledge of its conclusion. Together the whole becomes greater than the sum of its parts. The repeatability of the construction sequence is an extrapolation of the surrounding system. The orderly sequence of wooden lath in an erosion fence, the regular undulating ridges of myriad sea shells, the duplication of skate egg casings, or the methodical cycle of the sun and tides, affirm the natural order and validate the sequential progression of building.

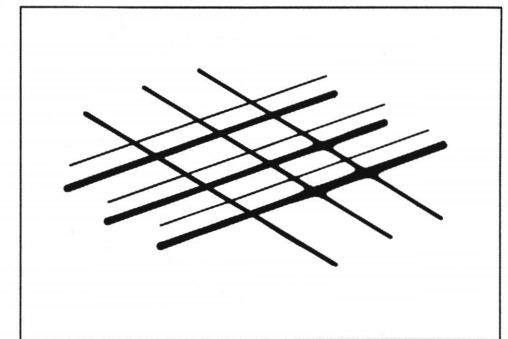
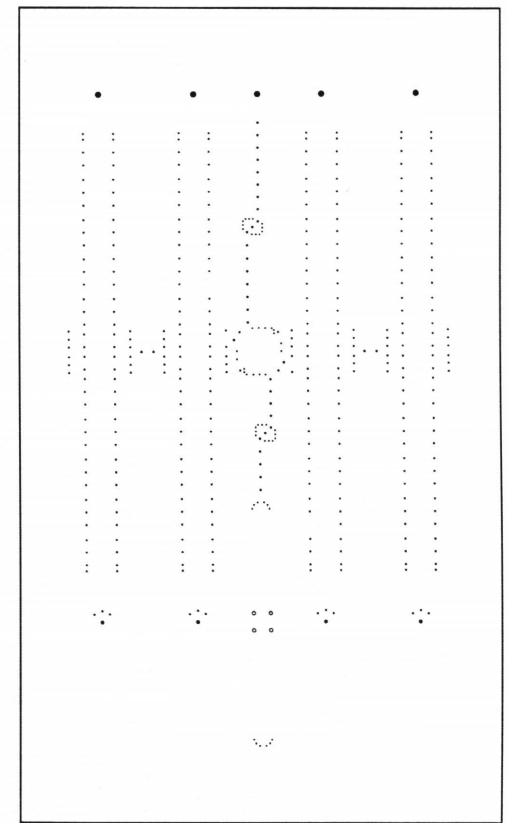
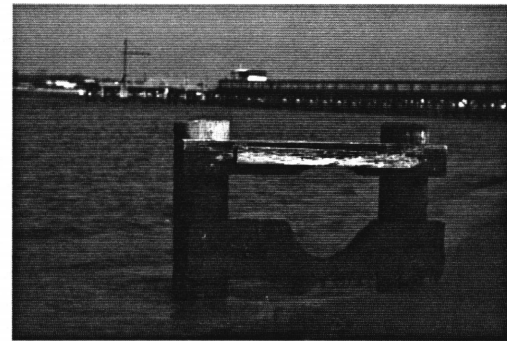
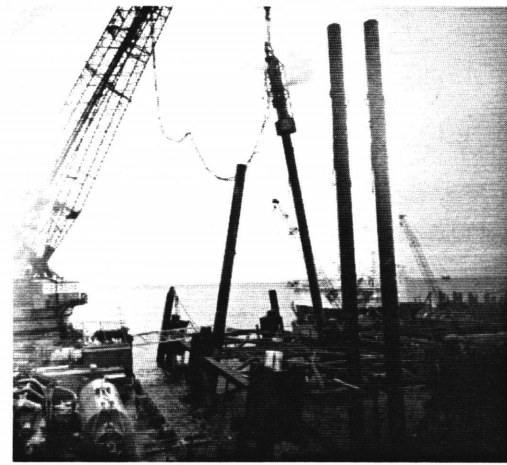



model

*a 3D view*

*"Bewildered, the form maker  
stands alone."*

Christopher Alexander

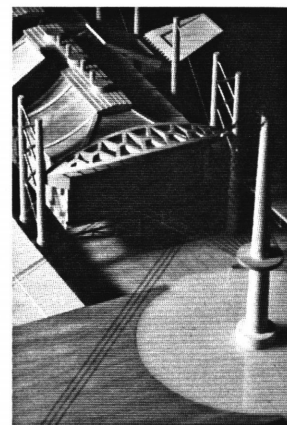
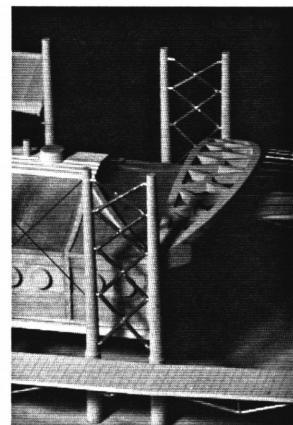
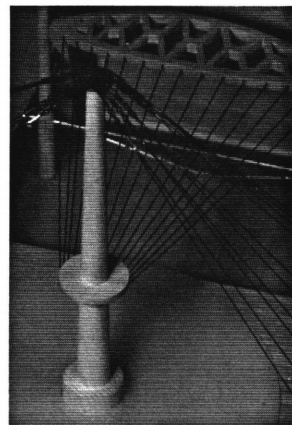
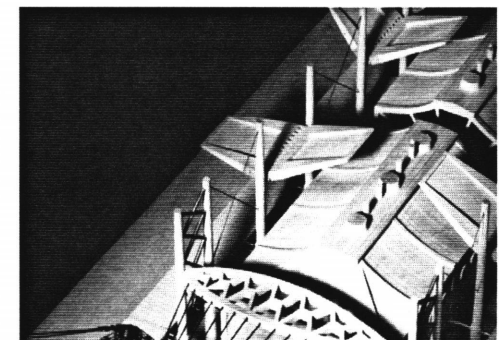
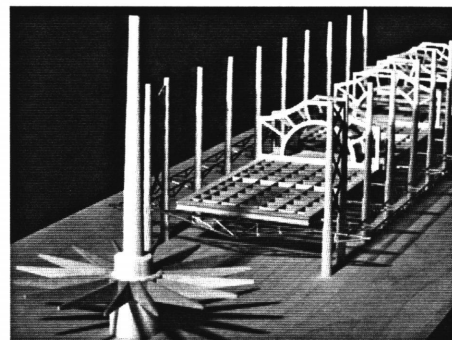
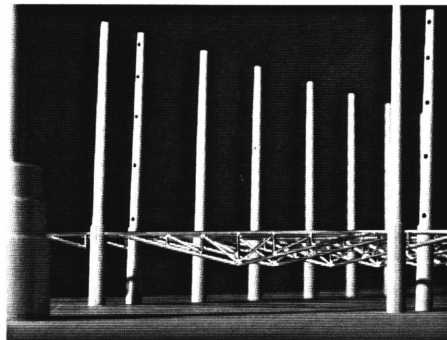
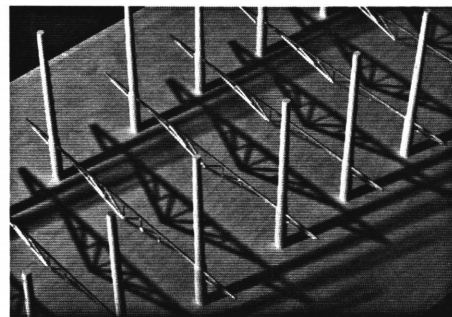
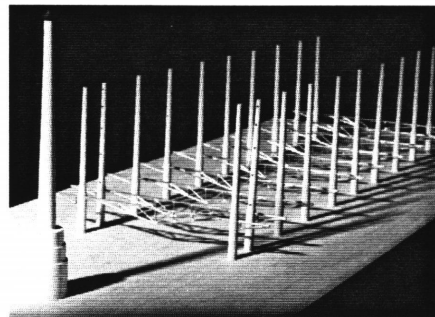
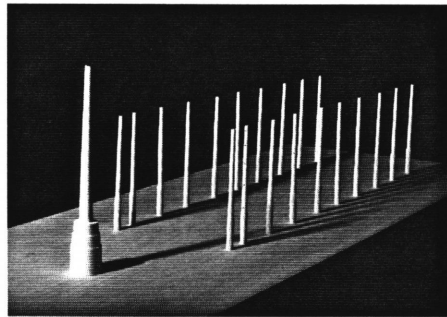
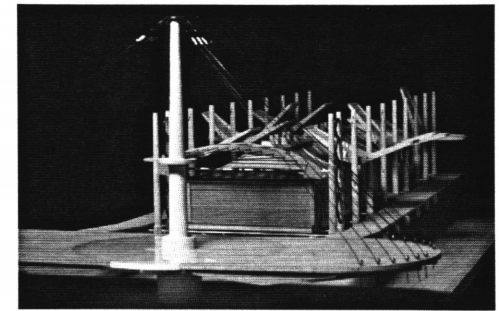

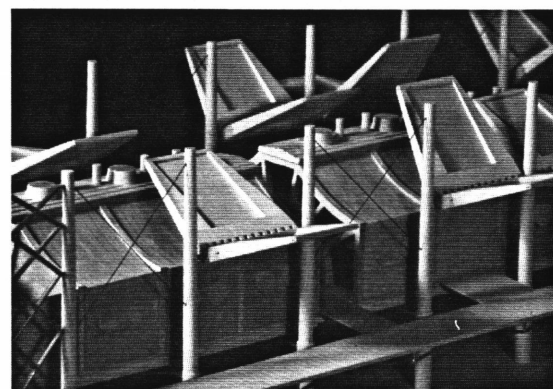
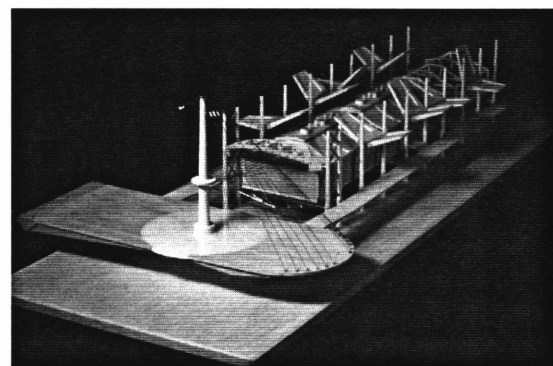
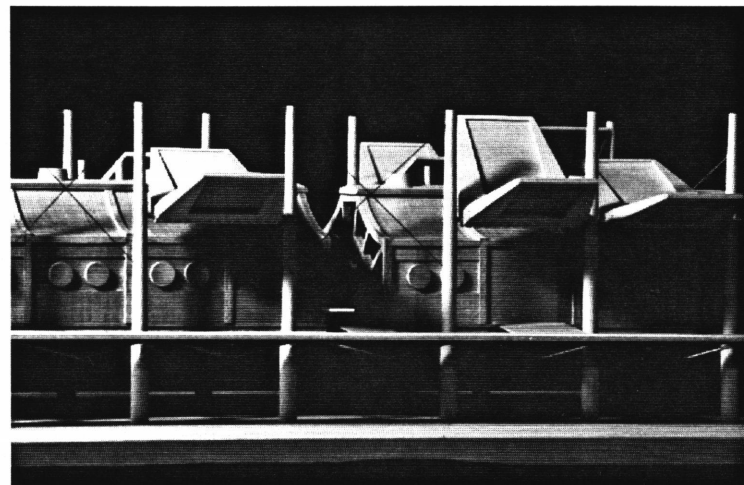
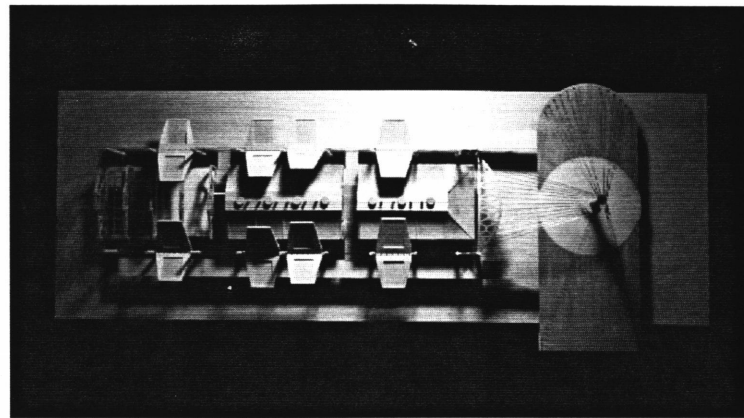
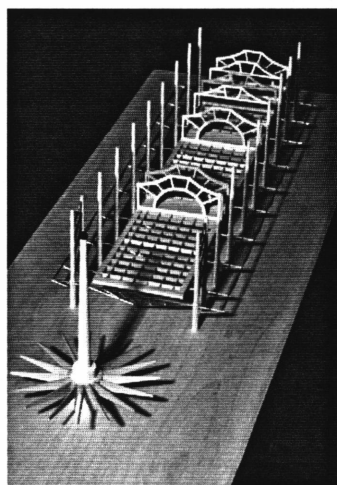
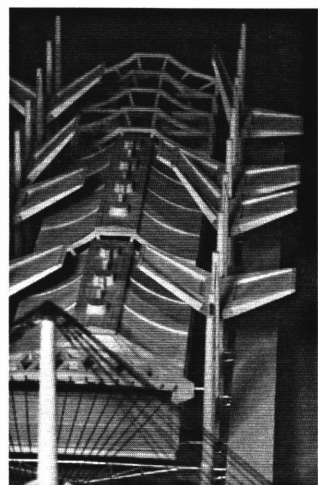
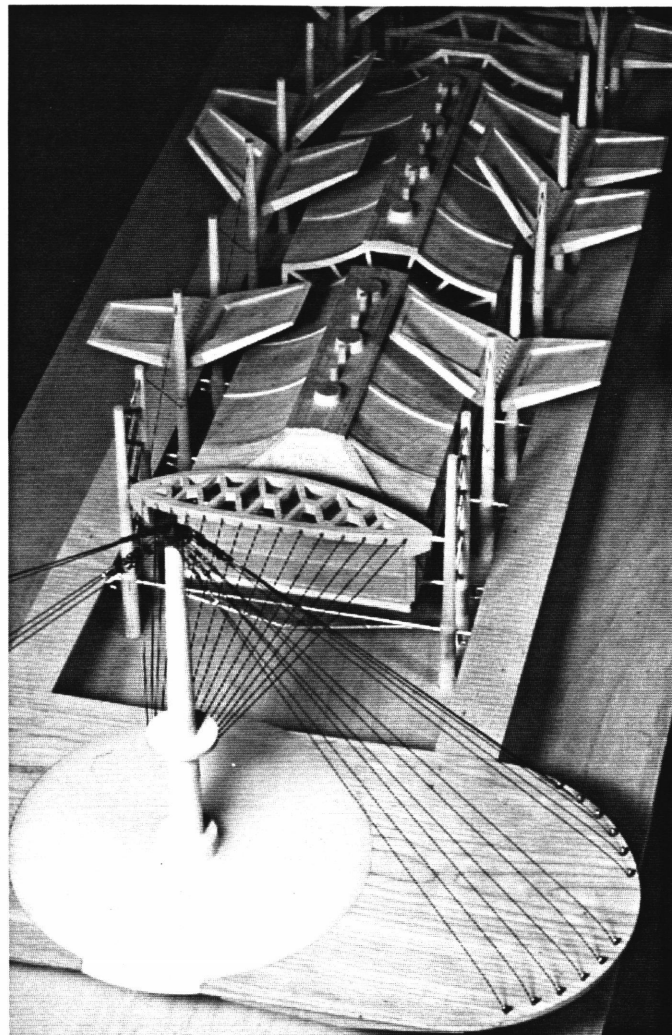
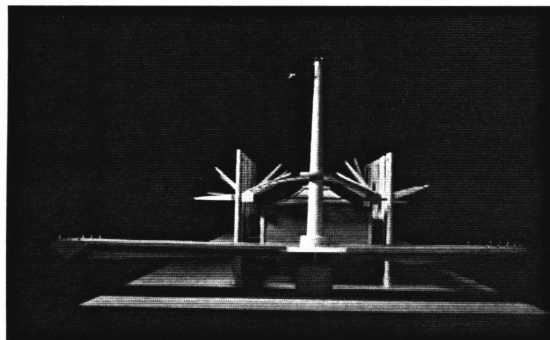
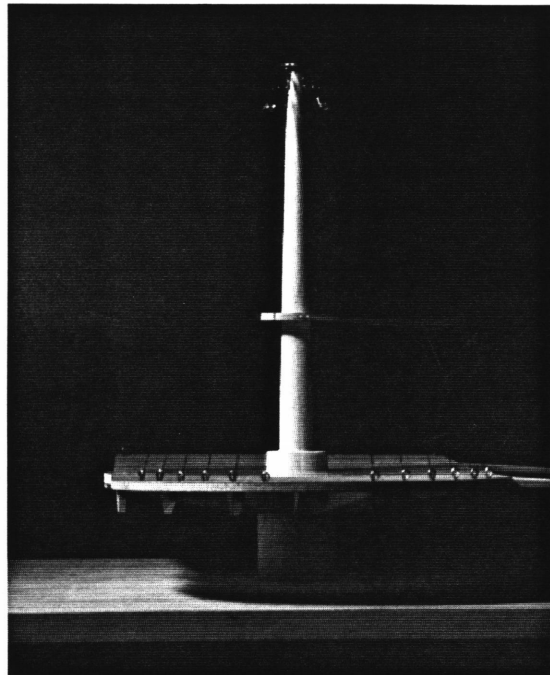

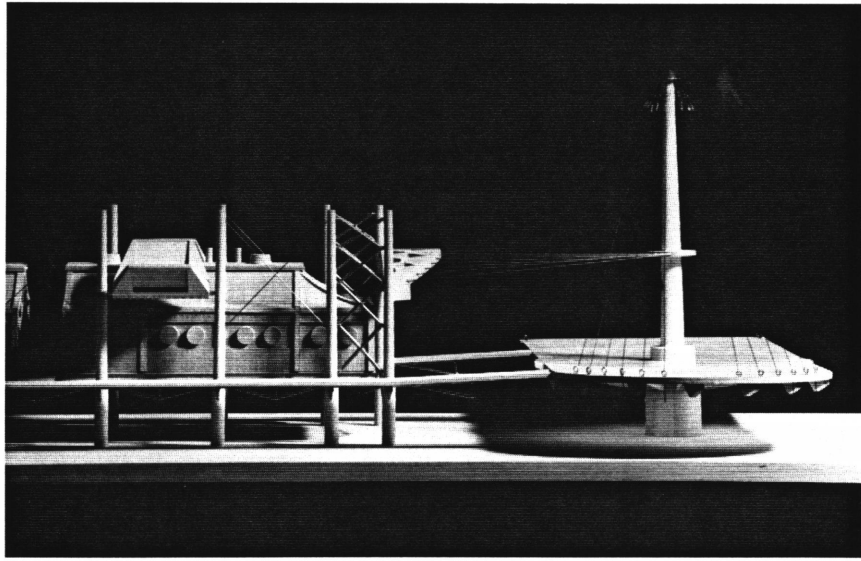
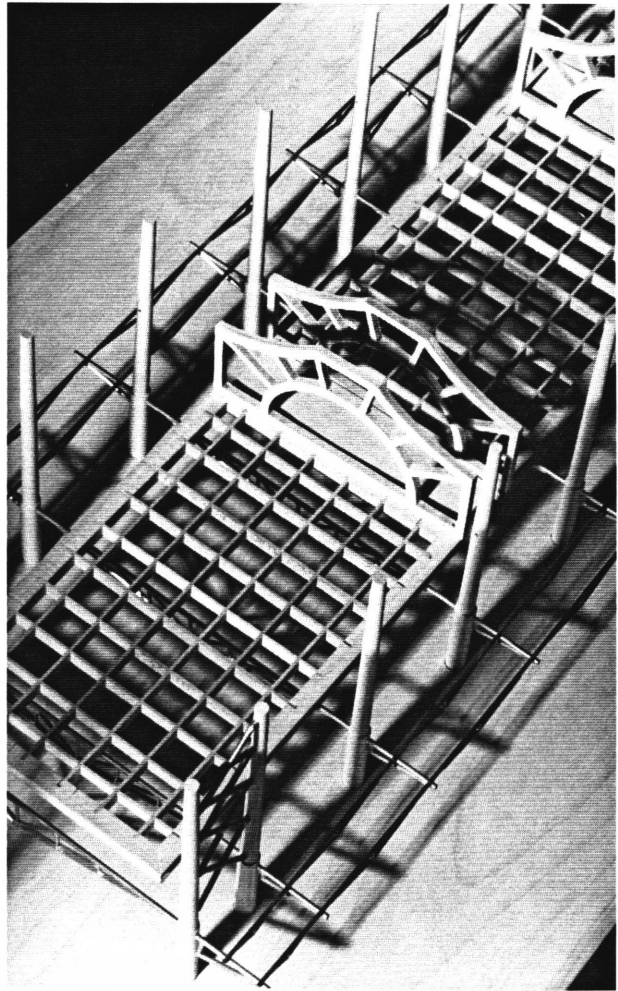
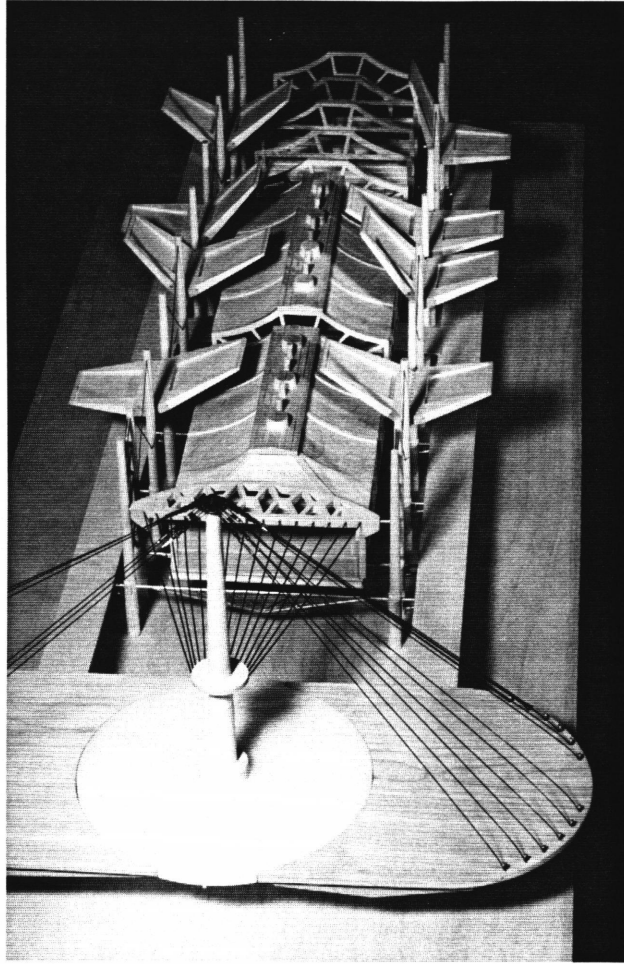

## conclusion

*a retrospective*

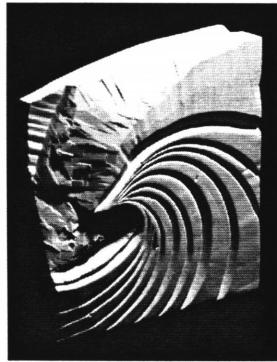

*"Once the concepts of others have been assimilated,  
a personal language must assert itself."*

Carlo Scarpa

By paying homage to the forms and forces indigenous to the coastal milieu, the Oceanographic Research Facility avoids the tendency towards empty virtuosity and gains purpose and resolve. By recognizing that building is not an isolated act of aggression, but a sensitive compliance to what's existing, a direction, an avenue of intent, emerges. The overt as well as subtle qualities of a building site afford an opportunity to make connections and to enlarge on what exists. The "poignant qualities" become opportunities to reformulate, transform, or abstract and to explore the boundaries of the real and the imaginary. By linking perception with expression, the memory is refreshed and a legacy served.

A building as a bridge linking two mutually dependent worlds, relies on the connection to a local memory of time and place. By enlisting memory's images and sensations in the design, the larger connection of building to place is addressed. The eye and mind collect and organize the images and intellectually transform them for the work. While an exact translation is not the intent, the Oceanographic Research Facility serves as a vehicle for expression, the experimental ground for thoughts and ideas. The physical manifestation of those thoughts and ideas as a building, however, is no real proof of derivation or validation of anything.

Arguably, architecture is personal. In a romantic sense it has been described as a "complicated act of faith." In a more pragmatic view it has been relegated to "mastering the mechanism of choice." Sometimes beyond all that is technical and rational, it is desire that drives the work. As Frank Lloyd Wright said: "The circumference of Architecture is changing with astonishing rapidity, but its center remains unchanged: the human heart."

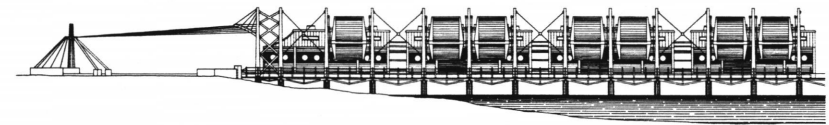

The ultimate success of any project lies with the individual. Beyond the programmatic and technical complexity is an internal connection and indication of completeness. One must address fundamental questions. In the mind's eye can the building be visualized as intended. Is the sequence of imaginations apparent?

I walked along the shoreline of Balder's Pond and imagined the building from all angles. I stood on the highest point on the coastline, the top of the Indian River Bridge that had provided one of the generating images, and saw the pond beyond the Coast Guard station. From the land mass anchored by the communications tower and water trough, uniform lines of masts marched out into the water as a repeating order of poles. In likewise uniformity, only alive and moving, huge birds glided and banked, and hovered in their most majestic way.

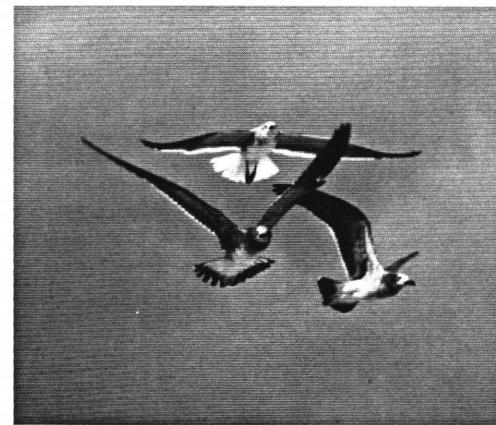

## Bibliography

---

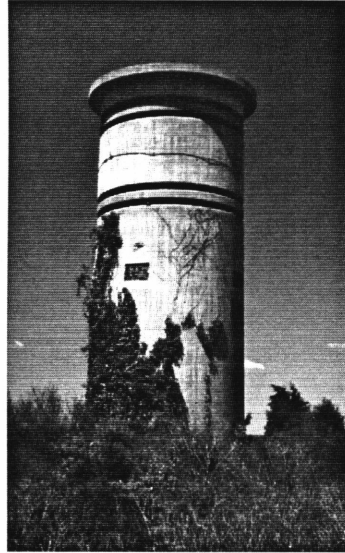

Albertini, Bianca, and Bagnoli, Sandro. *Carlo Scarpa: Architecture In Details*. The MIT Press, Cambridge, Massachusetts, London, England. 1988.

Alexander, Christopher. *Notes On The Synthesis Of Form*. Harvard University Press. Cambridge, Massachusetts, and London, England. 1964.

Bryant, Tracey L., and Pennock, Jonathan R., Editors. *The Delaware Estuary: Rediscovering A Forgotten Source*. University of Delaware, Sea Grant College Program.

Daiber, Franklin C. *Biological Studies On Indian River And Rehoboth Bays*. Marine Laboratories, University of Delaware.

Meggs, Philip B. *Type & Image: The Language of Graphic Design*. Van Nostrand Reinhold. New York. 1989.

Moore, Charles W., Mitchell, William J., Turnbull, Jr., William. *The Poetics Of Gardens*. The MIT Press. Cambridge, Massachusetts, London, England. 1988.

- Prouve, Jean. *Prefabrication: Structures and Elements*. Praeger Publishers.
- Sullivan, Barry James. *Industrialization in The Building Industry*. Van Nostrand Reinhold.
- Wachsman, Konrad. *The Turning Point of Building*. Reinhold Publishing Co. 1961
- Wurman, Richard Saul. *What Will Be Has Always Been-The Words of Louis I. Kahn*. Access Press Ltd. and Rizzoli International Publications, Inc. New York 1986.
- Wylson, Anthony. *Aquatecture-Architecture And Water*. The Architectural Press: London, Van Nostrand Reinhold Co.: New York. 1986.
- *Proceedings Coastal Processes and Shore Protection Seminar*. March 12-13, 1970. Wilmington, North Carolina.
- *Fishing Piers: What Cities Can Do*. The Waterfront Press. 1985
- *Port Design & Construction*. American Associations of Port Authorities.

**The vita has been removed from  
the scanned document**