

Agent-Based Game Theory Modeling for Driverless Vehicles at Intersections



**Morgan State University
The Pennsylvania State University
University of Maryland
University of Virginia
Virginia Polytechnic Institute & State University
West Virginia University**

**The Pennsylvania State University
The Thomas D. Larson Pennsylvania Transportation Institute
Transportation Research Building ❖ University Park, PA 16802-4710
Phone: 814-865-1891 ❖ Fax: 814-863-3707
www.mautc.psu.edu**

AGENT-BASED GAME THEORY MODELING FOR DRIVERLESS VEHICLES AT INTERSECTIONS

By: Hesham A. Rakha, Ismail H. Zohdy, and Raj K. Kamalanathsharma

Mid-Atlantic University Transportation Center
Final Report

Department of Civil and Environment Engineering
Virginia Polytechnic Institute and State University

February 19, 2013

1. Report No. VT-2010-02	2. Government Accession No. 01463577	3. Recipient's Catalog No.	
4. Title and Subtitle: Agent-Based Game Theory Modeling for Driverless Vehicles at Intersections		5. Report Date February 19, 2013	
		6. Performing Organization Code	
7. Author(s) Hesham A. Rakha, Ismail H. Zohdy, and Raj K. Kamalanathsharm		8. Performing Organization Report No.	
9. Performing Organization Name and Address Virginia Tech Transportation Institute 3500 Transportation Research Plaza Blacksburg, VA 24061		10. Work Unit No. (TRAVIS)	
		11. Contract or Grant No. DTRT07-G-0003	
12. Sponsoring Agency Name and Address US Department of Transportation Research & Innovative Technology Admin UTC Program, RDT-30 1200 New Jersey Ave., SE Washington, DC 20590		13. Type of Report and Period Covered Final Report	
		14. Sponsoring Agency Code	
15. Supplementary Notes			
16. Abstract <p>This report presents three research efforts that were published in various journals. The first research effort presents a reactive-driving agent based algorithm for modeling driver left turn gap acceptance behavior at signalized intersections. This model considers the interaction between driver characteristics and vehicle physical capabilities. The model explicitly captures the vehicle constraints on driving behavior using a vehicle dynamics model. In addition, the model uses the driver's input and the psychological deliberation in accepting/rejecting a gap. The model is developed using a total of 301 accepted gaps and subsequently validated using 2,429 rejected gaps at the same site and also validated using 1,485 gap decisions (323 accepted and 1,162 rejected) at another site. The proposed model is considered as a mix between traditional and reactive methods for decision making and consists of three main components: input, data processing and output. The input component uses sensing information, vehicle and driver characteristics to process the data and estimate the critical gap value. Thereafter, the agent decides to either accept or reject the offered gap by comparing to a driver-specific critical gap (the offered gap should be greater than the critical gap for it to be accepted). The results demonstrate that the agent-based model is superior to the standard logistic regression model because it produces consistent performance for accepted and rejected gaps (correct predictions in 90% of the observations) and the model is easily transferable to different sites. The proposed modeling framework can be generalized to capture different vehicle types, roadway configurations, traffic movements, intersection characteristics, and weather effects on driver gap acceptance behavior. The findings of this research effort is considered as an essential stage for modeling autonomous/driverless vehicles</p> <p>The second effort develops a heuristic optimization algorithm for automated vehicles (equipped with cooperative adaptive cruise control CACC systems) at uncontrolled intersections using a game theory framework. The proposed system models the automated vehicles as reactive agents interacting and collaborating with the intersection controller (manager agent) to minimize the total delay. The system is evaluated using a case study considering two different intersection control scenarios: a four-way stop control and the proposed intersection controller framework. In both scenarios, four automated vehicles (a single vehicle per approach) were simulated using a Monte Carlo simulation that was repeated 1000 times. The results show that the proposed system reduces the total delay relative to a traditional stop control by 35 seconds on average, which corresponds to an approximately 70 percent reduction in the total delay.</p> <p>The third effort presents a new tool for optimizing the movements of autonomous/driverless vehicles through intersections: iCACC. The main concept of the proposed tool is to control vehicle trajectories using Cooperative Adaptive Cruise Control (CACC) systems to avoid collisions and minimize intersection delay. Simulations were executed to compare conventional signal control with iCACC considering two measures of effectiveness - delay and fuel consumption. Savings in delay and fuel consumption in the range of 91 and 82 percent relative to conventional signal control were demonstrated, respectively. It is anticipated that the findings of this report may contribute in the future of advanced vehicles control and connected vehicles applications.</p>			
17. Key Words Agent-based, Game theory, Driverless vehicles		18. Distribution Statement No restrictions. This document is available from the National Technical Information Service, Springfield, VA 22161	
19. Security Classif. (of this report)	20. Security Classif. (of this page)	21. No. of Pages 43	22. Price

ABSTRACT

This report presents three research efforts that are being published in various journals. The first research effort presents a reactive-driving agent based algorithm for modeling driver left turn gap acceptance behavior at signalized intersections. This model considers the interaction between driver characteristics and vehicle physical capabilities. The model explicitly captures the vehicle constraints on driving behavior using a vehicle dynamics model. In addition, the model uses the driver's input and the psychological deliberation in accepting/rejecting a gap. The model is developed using a total of 301 accepted gaps and subsequently validated using 2,429 rejected gaps at the same site and also validated using 1,485 gap decisions (323 accepted and 1,162 rejected) at another site. The proposed model is considered as a mix between traditional and reactive methods for decision making and consists of three main components: input, data processing and output. The input component uses sensing information, vehicle and driver characteristics to process the data and estimate the critical gap value. Thereafter, the agent decides to either accept or reject the offered gap by comparing to a driver-specific critical gap (the offered gap should be greater than the critical gap for it to be accepted). The results demonstrate that the agent-based model is superior to the standard logistic regression model because it produces consistent performance for accepted and rejected gaps (correct predictions in 90% of the observations) and the model is easily transferable to different sites. The proposed modeling framework can be generalized to capture different vehicle types, roadway configurations, traffic movements, intersection characteristics, and weather effects on driver gap acceptance behavior. The findings of this research effort is considered as an essential stage for modeling autonomous/driverless vehicles

The second effort develops a heuristic optimization algorithm for automated vehicles (equipped with cooperative adaptive cruise control CACC systems) at uncontrolled intersections using a game theory framework. The proposed system models the automated vehicles as reactive agents interacting and collaborating with the intersection controller (manager agent) to minimize the total delay. The system is evaluated using a case study considering two different intersection control scenarios: a four-way stop control and the proposed intersection controller framework. In both scenarios, four automated vehicles (a single vehicle per approach) were simulated using a Monte Carlo simulation that was repeated 1000 times. The results show that the proposed system reduces the total delay relative to a traditional stop control by 35 seconds on average, which corresponds to an approximately 70 percent reduction in the total delay.

The third effort presents a new tool for optimizing the movements of autonomous/driverless vehicles through intersections: iCACC. The main concept of the proposed tool is to control vehicle trajectories using Cooperative Adaptive Cruise Control (CACC) systems to avoid collisions and minimize intersection delay. Simulations were executed to compare conventional signal control with iCACC considering two measures of effectiveness - delay and fuel consumption. Savings in delay and fuel consumption in the range of 91 and 82 percent relative to conventional signal control were demonstrated, respectively. It is anticipated that the findings of this report may contribute in the future of advanced vehicles control and connected vehicles applications.

**AN AGENT-BASED FRAMEWORK FOR MODELING DRIVER LEFT-TURN GAP
ACCEPTANCE BEHAVIOR AT SIGNALIZED INTERSECTIONS**

Ismail H. Zohdy

Center for Sustainable Mobility, Virginia Tech Transportation Institute
3500 Transportation Research Plaza, Blacksburg, VA 24061

Phone: (540) 231-1506 Fax: (540) 231-1555

izohdy@vt.edu

Hesham A. Rakha

Charles E. Via, Jr. Department of Civil and Environmental Engineering
3500 Transportation Research Plaza, Blacksburg, VA 24061

Phone: (540) 231-1505 Fax: (540) 231-1555

hrakha@vt.edu

ABSTRACT

The paper develops a reactive-driving agent based algorithm for modeling driver left turn gap acceptance behavior at signalized intersections. This model considers the interaction between driver characteristics and vehicle physical capabilities. The model explicitly captures the vehicle constraints on driving behavior using a vehicle dynamics model. In addition, the model uses the driver's input and the psychological deliberation in accepting/rejecting a gap. The model is developed using a total of 301 accepted gaps and subsequently validated using 2,429 rejected gaps at the same site and also validated using 1,485 gap decisions (323 accepted and 1,162 rejected) at another site. The proposed model is considered as a mix between traditional and reactive methods for decision making and consists of three main components: input, data processing and output. The input component uses sensing information, vehicle and driver characteristics to process the data and estimate the critical gap value. Thereafter, the agent decides to either accept or reject the offered gap by comparing to a driver-specific critical gap (the offered gap should be greater than the critical gap for it to be accepted). The results demonstrate that the agent-based model is superior to the standard logistic regression model because it produces consistent performance for accepted and rejected gaps (correct predictions in 90% of the observations) and the model is easily transferable to different sites. The proposed modeling framework can be generalized to capture different vehicle types, roadway configurations, traffic movements, intersection characteristics, and weather effects on driver gap acceptance behavior. It is anticipated that these findings may be used to develop weather-specific traffic signal timings and also for the future of vehicle-to-vehicle communications.

INTRODUCTION

The use of *agents* of many different kinds in a variety of fields of computer science and artificial intelligence is increasing rapidly due to their wide applicability. Agent-based modeling "ABM" (or multi-agent modeling) has emerged as a modeling algorithm for modeling complex systems composed of interacting and autonomous units (i.e. agents). Agents have behaviors, often described by simple rules, and interact with other agents, which in turn influence their behaviors. The level of an agent's intelligence could vary from having pre-determined roles and responsibilities to a learning entity. There are a growing number of agent-based applications in a variety of fields and disciplines, like for example: the stock market (e.g. [1, 2]), molecular self-assembly (e.g. [3]), biological science (e.g. [4-6]), etc. In addition, a number of transportation related agent-based applications have already been studied in the literature. Chen and Cheng (2010 [7]) presented a general overview of agent-based modeling techniques applied to many aspects of traffic and transportation systems, including decision support systems, dynamic routing and congestion management, and intelligent traffic control.

In the case of traffic control systems, Ossowski et al. [8] presented a decision support system that was designed for the management of the urban motorway network around Barcelona. Roozmond [9] described the development of an agent-based urban traffic control system that reacted to changes in the traffic environment and adapted its parameters in real-time in accordance with travel demand, traffic flow and changes to the traffic environment. Dresner and Stone ([10-13]) proposed a multi-agent reservation-based algorithm which consisted of two types of agents: intersection managers and driver agents. Zou and Levinson [14] presented a framework for the impact of microscopic adaptive control on traffic delay and collisions at intersections using multi-agent systems and ad-hoc network communications. Both the vehicles and the management components were represented by respective agents. Bazzan [15] proposed a

multi-agent system for interacting traffic signal controllers along an arterial network using a game theory algorithm. The decision of the signal agents involved decisions to change phases for the synchronization of the traffic signals along an arterial.

In addition, a number of studies proposed the implementation of different agent-based architectures for modeling driver route choice decisions. For example, Dia and Purchase [16] and Dia [17] proposed the use of an agent architecture composed of capabilities and behavioral rules to model individual drivers based on behavioral surveys. Rossetti et al. [18] proposed the implementation of similar techniques within the DRACULA traffic simulation model. Wahle et al. [19] proposed a two-layer agent architecture for modeling individual driver route choice behavior. Rakha et al. developed demonstrated the INTEGRATION agent-based framework for modeling various user-equilibrium and eco-routing strategies [20].

Hernandez et al. [21] described the development of a knowledge-based agent architecture for real-time traffic management at a strategic level in urban, interurban or mixed areas. Dia [22] demonstrated the feasibility of using autonomous agents for modeling dynamic driver behavior and analyzing the effect of ATIS “Advance Traveler information systems” on the performance of a congested commuting corridor in Australia. Jin et al. [23] proposed an agent based hybrid model for traffic information intelligent control simulation that perform the basic interface, planning and support services for managing different types of “DRT” services to optimize driver route selection. In summary, agent-based modeling concepts have been used in many transportation applications including traffic management, traffic control, route choice, traffic information systems, decision support, etc.

In this paper, we develop a novel application for agent-based modeling within the context of gap acceptance modeling using reactive-driving agent algorithms. Gap acceptance is defined as the process that occurs when a traffic stream (known as the opposed flow) has to either cross or merge with another traffic stream (known as the opposing flow). Examples of gap acceptance behavior occur when vehicles on a minor approach cross a major street at a two-way stop controlled intersection, when vehicles make a left turn through an opposing through movement at a signalized intersection, or when vehicles merge onto a freeway. This paper focuses on crossing gap acceptance behavior for permissive left turns.

A gap is defined as the elapsed-time interval between arrivals of successive vehicles in the opposing flow at a specified reference point in the intersection area. The minimum gap that a driver is willing to accept is generally called the critical gap. The Highway Capacity Manual (HCM) (2000) [24] defines the critical gap as the “*minimum time interval between the front bumpers of two successive vehicles in the major traffic stream that will allow the entry of one minor-street vehicle.*” The HCM 2000 considers the critical gap accepted by left-turn drivers as a deterministic value equal to 4.5 s at signalized intersections with a permitted left-turn phase. This value is independent of the number of opposing-through lanes to be crossed by the opposed vehicles and weather condition. Since the critical gap of a driver cannot be measured directly, censored observations (i.e., accepted and rejected gaps) are used to compute critical gaps. For more than three decades research efforts have attempted to model driver gap acceptance behavior, using either deterministic or probabilistic methods. The deterministic critical values are treated as a single threshold for accepting or rejecting gaps. Examples of deterministic methods include Raff’s [25] and Greenshields’ [26, 27] methods. The stochastic or probabilistic approach to modeling gap acceptance behavior involves constructing either a logit [28] or probit model [29, 30] using some maximum likelihood calibration technique. The fundamental assumption is that drivers will accept all gaps that are larger than the critical gap and reject all smaller gaps.

STUDY OBJECTIVE AND PAPER LAYOUT

The objective of this study is to develop a reactive-driving agent-based framework for modeling driver gap acceptance behavior. The proposed model is considered an interaction between driver characteristics and vehicle physical capabilities. The model is physical because it captures the vehicle constraints on driver gap acceptance behavior. Alternatively, the model captures the human's psychological deliberation in gap acceptance behavior.

In terms of the paper layout initially the data gathering procedures and a description of the data is provided. Subsequently, the framework for the reactive-driving agent model is presented followed by the critical gap estimation procedures using two different methods. The application of the agent-based model on a different data set is then discussed. Finally, the summary and conclusions of the paper are presented.

STUDY SITE DESCRIPTION AND DATA ACQUISITION EQUIPMENT

While the proposed framework is general, we demonstrate this approach using a sample intersection to provide a practical example of the model application. The study site that is considered in this study is the signalized intersection of Depot Street and North Franklin Street (Business Route 460) in Christiansburg, Virginia. A schematic of the intersection is shown in Figure 1a. It consists of four approaches at approximately 90° angles. The posted speed limit for the eastbound and northbound approaches was 35 mph and for the westbound and southbound approaches was 25 mph at the time of the study.

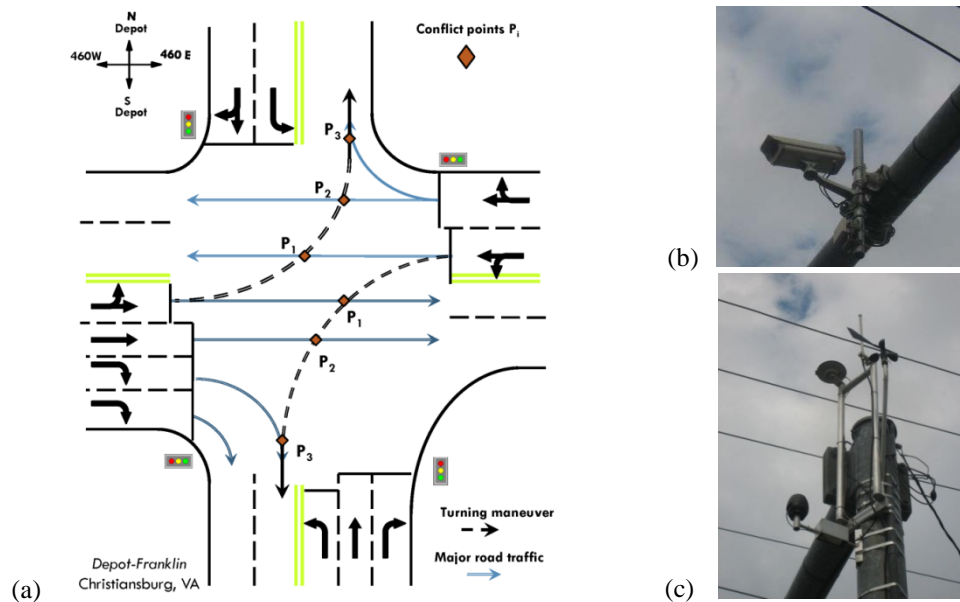

Figure 1: (a) Layout of Study Intersection; (b) Video Surveillance System; and (c) Weather Monitoring System

The signal phasing of the intersection included three phases, two phases for the Depot street North and South (one phase for each approach) and one phase for the Route 460 (two approaches discharging during the same phase) with a permissive left turn movement. Figure 1a illustrates the movement of vehicles during the green phase of Route 460 and the dashed lines

show the left turn vehicle trajectory where drivers are facing a gap acceptance/rejection situation. The dashed line is opposed by the through movements at three conflict points P1, P2 and P3 respectively. Each conflict point presents the location of possible collision with the through opposing movement. The data acquisition hardware of the study site consisted of two components:

- (a) Video cameras to collect the visual scene (Figure 1b). There were four cameras installed at the intersection (one camera for each approach) to provide a video feed of the entire intersection environment at 10 frames per second.
- (b) Weather station (Figure 1c). The weather station provided weather information every minute. The collected weather data included precipitation, wind direction, wind speed, temperature, barometric pressure, and humidity level.

The video data were reduced manually by recording the time instant at which a subject vehicle initiated its search to make a left turn maneuver, the time step at which the vehicle made its first move to execute its left turn maneuver, and the time the left turning vehicle reached each of the conflict points. In addition, the time stamps at which each of the opposing vehicles passed the conflict points were identified. The final dataset that was constructed consisted of a total of 2,730 gaps of which 301 were accepted and 2,429 were rejected. These 2,730 observations included 2,017 observations for dry conditions and 713 observations for different rain intensity levels (from 0.254 cm/hr up to 9.4 cm/hr). It should be stated that it is only considered passenger (sedan) vehicles in this study.

REACTIVE-DRIVING AGENT BASED MODELING FRAMEWORK

Agents are considered interactive units that have their own plans and goals using their sensed attributes to achieve these goals and plans. A vehicle with its driver can also be viewed as an agent; it can sense the environment by communicating with other vehicles on the road. Consequently, intelligent agents can be used to simulate the driving behavior of individual drivers where each agent's general goal is to reach its destination safely in the fastest possible way. The adaptability and flexibility of an intelligent agent makes it possible to control various types of vehicles with different driving behavior. Each agent can be equipped with its own attributes to simulate driving capabilities and vehicle characteristics to model inter- and intra-variability between drivers.

In this paper, we propose the use of a "reactive-driving" agent-based approach for modeling the gap acceptance/rejection behavior for left-turn vehicles. The reactive agents, (also called reflex or behavior-based agents) are inspired by the research done in robotic control. The concept of reactive-driving agents modeling was illustrated in few literature (e.g. [10]), behavior-based robotics [11] and microscopic traffic simulation [31]. The traditional agent architecture uses standard search-based techniques, and a plan is constructed for the agent to achieve its goal [31-33]. Traditional agent architectures applied in artificial intelligence use sensor information to create a world model. Using sensor constraints and uncertainties cause the world model to be incomplete or possibly even incorrect. On the other hand, pure reactive agents have no representation or symbolic model of their environment. The main advantage of reactive agents is that they are robust and have a fast response time. This is the reason that most reactive agents use non-reactive enhancements [31].

The proposed reactive-driving agent is considered as a mix between traditional and reactive methods for decision making as illustrated in Figure 2. The reactive-driving agent layout consists of three main components: Input, Data processing and Output. The input component fuses information from weather stations (rain intensity, roadway surface condition, etc.),

intersection characteristics (number of lanes, speed limit, etc.) and the offered gap sizes to the driver. Thereafter, the vehicle characteristics, travel time estimated for the vehicle to cross the intersection and the minimum additional time needed by the driver as a buffer of safety are added to the information. Subsequently, all input information is processed in the “Memory and Data Processing” component to estimate the minimum acceptable gap for the driver (i.e. critical gap). Comparing the offered gap size stored in the memory to the critical gap of the driver, will lead to the Output Component (i.e. decision making); if the offered gap is greater than the critical gap, the agent will accept the gap; otherwise it will reject it.

The agent-based modeling approach entails estimating the duration of time it would take the subject vehicle to traverse a conflict point and avoid collision with an opposing vehicle. Typically, the driver requires some additional buffer of safety to ensure that no collision occurs. Consequently, the modeling of driver gap acceptance behavior requires the modeling of driver acceleration behavior and the additional buffer of safety the driver requires in accepting a gap for the estimation of the critical gap size as will be described in the following sections.

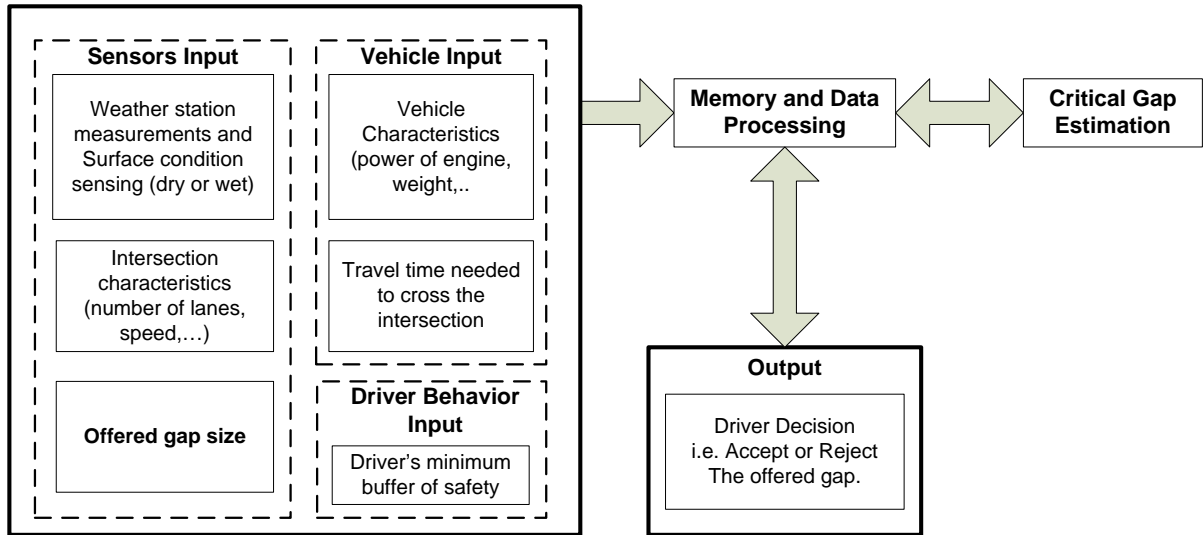

Figure 2: The reactive-driving agent layout

CRITICAL GAP ESTIMATION USING TRADITIONAL APPROACHES

Given that the driver response is a discrete variable (reject or accept) while the independent variables are continuous, a logistic model was fit to the data. Three multivariate models were evaluated and compared. The final model that was selected was of the form

$$\text{logit}(p) = \beta_0 + \beta_1(g - \tau_t) + \beta_2(w) + \beta_3(r). \quad (1)$$

Where $\text{logit}(p)$ equals $\ln(p/(1-p))$; p is probability of accepting a gap; g is the gap size offered to the opposed vehicle (s); w is the duration of time that the driver waits in search of an acceptable gap (s); r is the rain intensity (cm/h); and τ_t is the median travel time to the conflict point (2.3 s in the case of the first conflict point and 3.5 s for the second). In calibrating the model to the field data using a generalized linear model (GLM) the model coefficients ($\beta_0, \beta_1, \beta_2$, and β_3) were estimated at -3.677, 0.771, 0.033, -0.623, respectively. The 95 percent confidence

limits were estimated at (-4.011, -3.367), (0.698, 0.850), (0.014, 0.053), and (-1.167, -0.217), respectively.

Based on Equation (1), the critical gap can then be computed by setting the probability of accepting a gap to 0.5 which results in a logit function that equals zero. Consequently the critical gap (t_c) can be computed as

$$t_c = \tau_i - \frac{\beta_0}{\beta_1} - \frac{\beta_2}{\beta_1} w - \frac{\beta_3}{\beta_1} r = \alpha_0 + \alpha_1 w + \alpha_2 r. \quad (2)$$

By applying the calibrated logit model coefficients (β_0 , β_1 , β_2 , and β_3) to Equation (2) the critical gap coefficients (α_0 , α_1 , and α_2) are computed to be 7.07, -0.04, and 0.81 for the first conflict point and 8.27, -0.04, 0.81 for the second conflict point, respectively. This implies that the critical gap decreases as the driver waits longer in search of an acceptable gap (i.e. drivers become more aggressive as they wait longer). Alternatively, the critical gap increases as the rain intensity increases (i.e. drivers become less aggressive as the rain intensity increases). Consequently, by knowing the rain intensity and the waiting time, the corresponding critical gap could be calculated.

CRITICAL GAP USING NEW PROPOSED APPROACH

The proposed agent-based approach can be considered as a driver-vehicle interaction model given that the model captures the psychological deliberation of the driver in addition to the physical constraints imposed by the vehicle. In addition, the model captures the interface between the vehicle tires and the roadway surface. The proposed model considers the driver specific critical gap (the minimum gap a driver is willing to accept) for each driver, as the summation of the travel time to reach the conflict point, the time needed to clear the length of the vehicle and an additional time as a buffer of safety as

$$t_c = t_T + t_L + t_S \quad (3)$$

Where; t_c is the critical gap value for each driver, t_L is the time required to clear the length of the vehicle and t_S is the buffer of safety time between the passage of the length of the vehicle the conflict point and reaching the opposing vehicle the same point. Figure 3 shows the critical gap t_c components. Each term of this equation will be described in detail in this section.

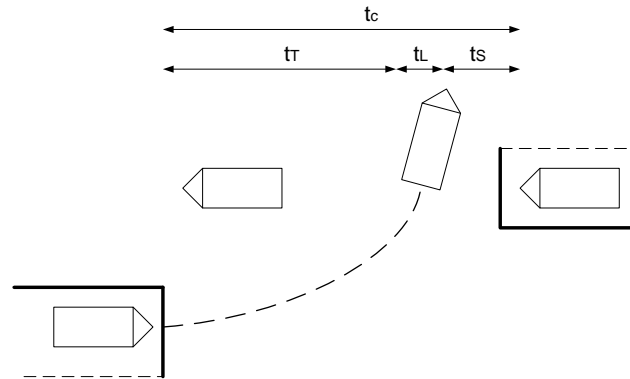

Figure 3: The proposed critical gap value for the agent-based model

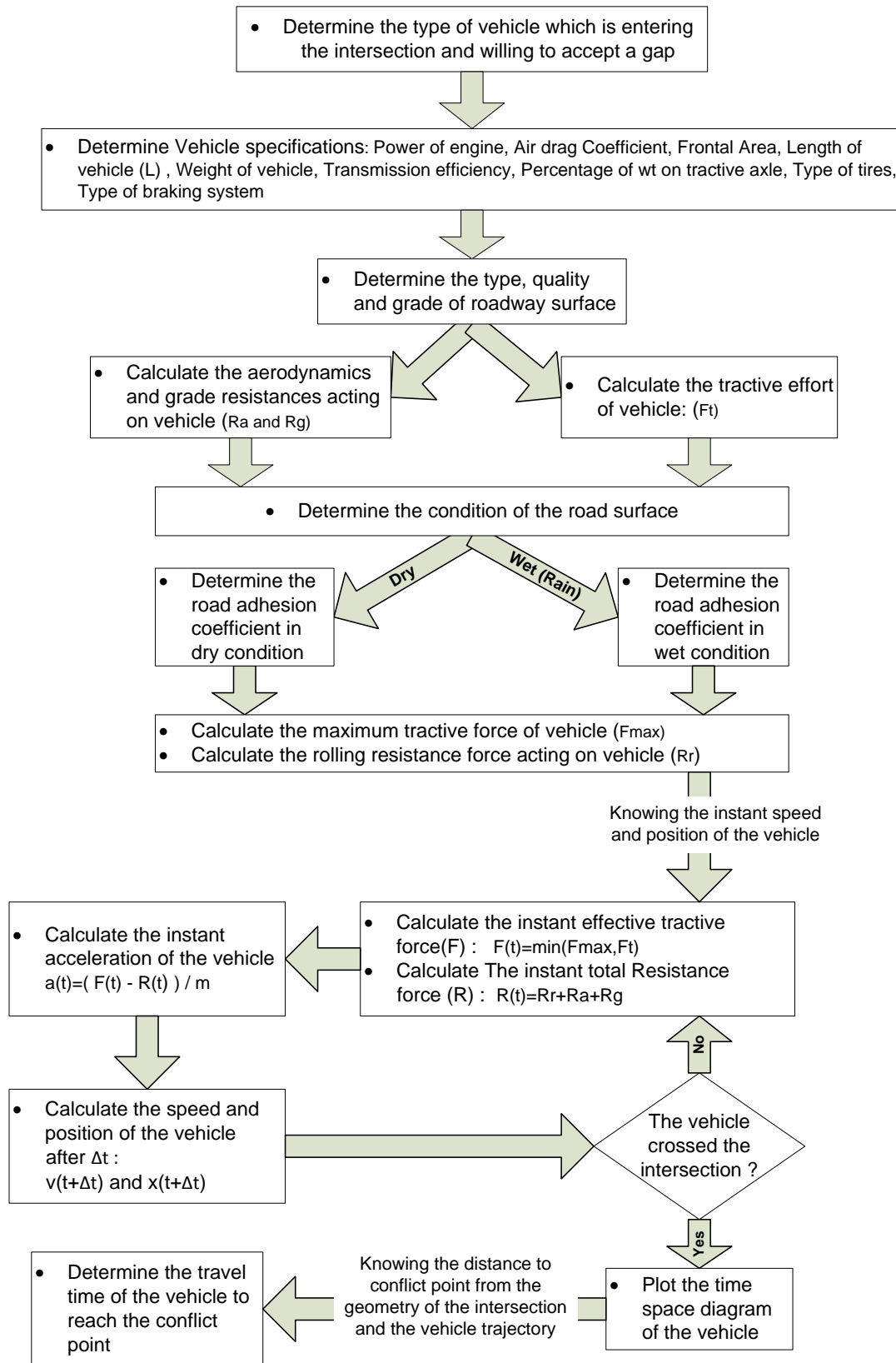

Figure 4: The proposed steps for estimating the travel time to a conflict point

Travel Time to Conflict Point (t_T)

Considering the type of vehicle entering the intersection and the roadway surface condition (wet or dry), the travel time required to reach the conflict point can be computed. The time required by a vehicle to reach a specific conflict point is a function of the distance to the conflict point, the type of vehicle, and the level of acceleration the driver is willing to exert. From the basic motion equation [34], the acceleration of the vehicle is the outcome of the total force (difference between the tractive forces and the resistance forces), which is affected by the road surface condition (rolling coefficients and coefficient of roadway adhesion) and the specifications of the vehicle (dimensions, power of engine, mass, tractive weight, etc.), as illustrated in Figure 4.

Vehicle Clearance Time (t_L)

After determining the time and distance to reach the conflict point; the speed of the vehicle can be estimated and by knowing the length of vehicle depending on its type (passenger vehicle, truck, etc.), the time needed to clear the vehicle length (t_L) can be computed.

Buffer of Safety (t_S)

The buffer of safety is defined as the time required by the driver in addition to the time required to traverse the conflict point in order to ensure that no conflict occurs with the opposing vehicle. Here we use the field data to generate the density distribution of t_s using field observed accepted gaps, as illustrated in Figure 5(a) and the cumulative distribution function in Figure 5(b). The distribution of t_s can be modeled using a normal distribution with mean (μ) equal to 3.679 s and a standard deviation (σ) equal to 1.645 s. However, such an approach ignores the correlation between with the other variables. In other words it is hypothesized that a driver who accelerates aggressively will most likely require a shorter buffer of safety and conversely a driver who does not accelerate aggressively would require a longer buffer of safety. Consequently, in computing the minimum buffer of safety required by a driver, the field data were used to establish a relationship between the travel time to the conflict point (t_T) and the corresponding 5th percentile buffer of safety (t_S) considering a bin size of 1 s for both dry and wet surface conditions, as demonstrated in Figure 5(c). It was assumed that the fifth percentile would represent a good estimate of the minimum buffer of safety. We used the 5th percentile as opposed to the minimum buffer of safety for two reasons: (1) to remove any potential outlier behavior and (2) to not have the buffer of safety more reflective of the overall driver population as opposed to the most aggressive driver. It is recommended that further analysis be done to investigate the impact of various buffer of safety values on the results.

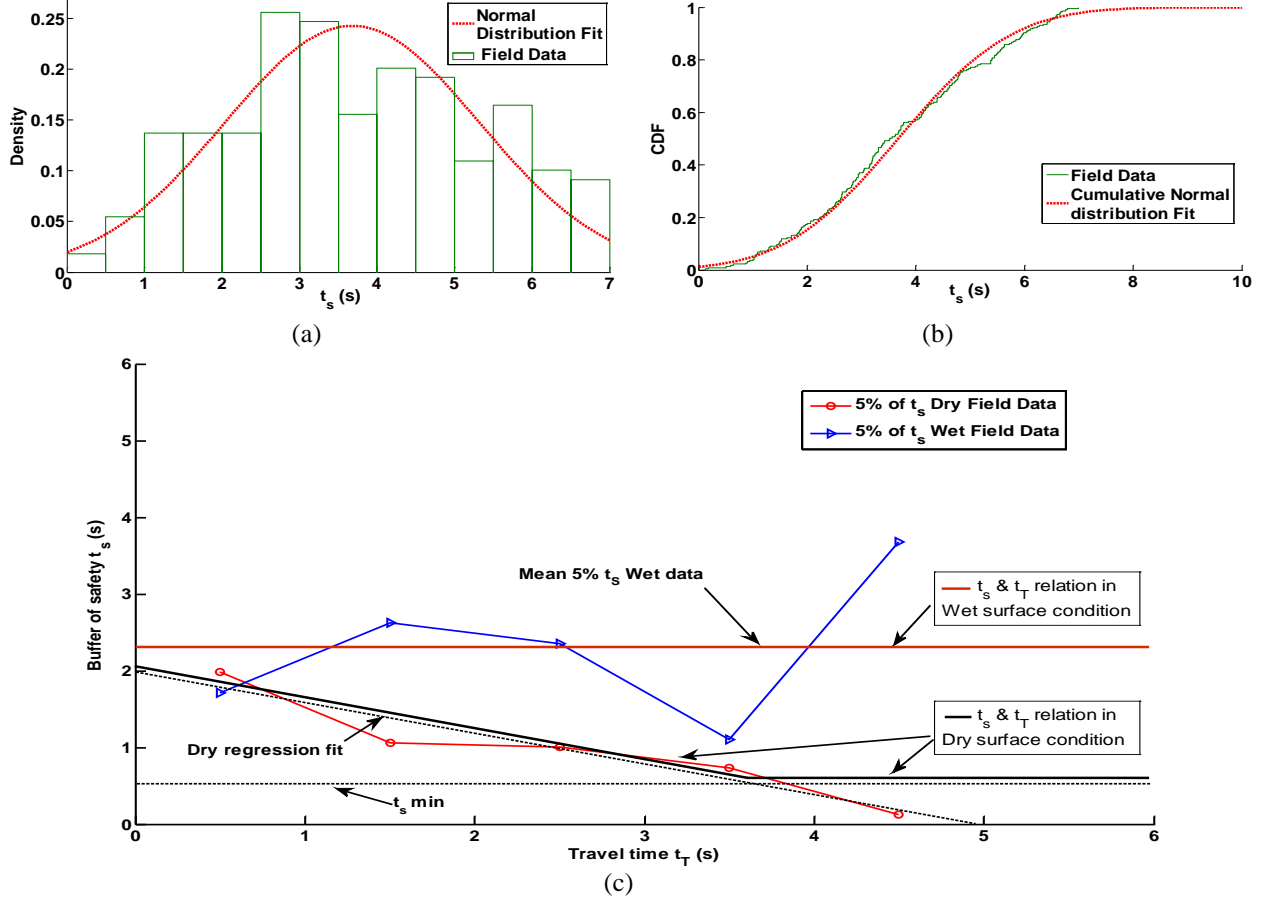

Figure 5: Buffer of safety distribution (t_s) and its relation to travel time (t_T)

In the case of dry roadway surface conditions, a relationship between t_T and t_s was established thus verifying the initial hypothesis. Consequently, the safety buffer was computed as the minimum of (a) a regression line with t_T as the explanatory variable and (b) a minimum value that was set at 0.5 s (time to travel the car length of a light-duty vehicle) as

$$\text{Dry } t_s = \max(1.99 - 0.40t_T, 0.5) \quad (4)$$

Where the coefficient of determination $R^2=90.4\%$ and $\sigma=0.24$ s.

Alternatively, for wet roadway surface conditions, because of the weak relationship between the t_s and the t_T variables ($R^2 < 10\%$), the t_s value was assumed to be independent of t_T with a value equal to the mean of the 5th percentile t_s where the mean fifth percentile t_s for wet surface conditions is 2.29 s with a standard deviation (σ) of 0.87 s. The 5th percentile was used in order to ensure that outlier data are not utilized in the building the model given that the critical gap is the smallest gap a driver is willing to accept.

Typical Vehicle Gap Acceptance Scenario

For illustration purposes we considered a Honda Civic-EX-Sedan 2006 model as a typical vehicle. We did consider other vehicles and found that differences among light duty vehicles were minimal and thus the use of a generic vehicle suffices for this effort. It should be noted that in the case of heavy-duty trucks and buses significant differences are observed. The Honda Civic vehicle has an engine power of 140 Horse Power (hp). The analysis assumes that the vehicle

starts from a complete stop at the intersection stop line and travels on a good flat asphalt surface (grade 0%).

The resistance force on the vehicle is computed as the sum of the aerodynamic, rolling, and grade resistance forces as expressed in Equation (5), where ρ is the density of air at sea level at a temperature of 15°C (59°F) (equal to 1.2256 kg/m³), C_D is the drag coefficient (unitless); C_h is a correction factor for altitude (unitless); A is the vehicle frontal area (m²); and C_r , c_2 , and c_3 are rolling resistance parameters that vary as a function of the road surface type, road condition, and vehicle tire type. The typical values of vehicle coefficients are provided in the literature [35].

$$R(t) = \frac{r}{25.92} C_D C_h A v(t)^2 + 9.8066m \frac{C_r}{1000} (c_2 v(t) + c_3) + 9.8066mG(t) \quad (5)$$

The driveline propulsive force is computed as the minimum of the engine or torque converter propulsive force and the maximum frictional force that can be sustained between the vehicle's wheels on the propulsive axle and the roadway surface as

$$F(t) = \min \left(\eta_d \times \frac{P_{max}}{v(t)}, 9.8066 \times m_{ta} \times \mu \right) \quad (6)$$

where η_d is the driveline efficiency; P_{max} is the maximum propulsive power; v is the vehicle speed (km/h); m_{ta} is the mass on the propulsive axle (kg); and μ is the coefficient of roadway adhesion. Table 1 shows the specifications and the parameters for the proposed vehicle.

By using the parameters of Table 1 and following the steps outlined in Figure 4, the time-space diagram for the typical proposed vehicle is plotted as shown in Figure 6. From the geometry of the intersection and by assuming the trajectory of the left turn vehicle as an ellipsoidal curve, the distance to the first conflict point (P1) and the second conflict point (P2) can be estimated as 9 and 13 m respectively measured from the stop line of the left turn lane. Thus, the travel time values (t_T) for each conflict point for both dry and wet cases is computed and also the time needed to clear the length of vehicle the conflict point (t_L). By knowing the travel time values, the buffer of safety value needed by the driver is computed using Equation (4) for dry condition or the mean value for wet condition. Based on these values the critical gap size (t_c) for both scenarios (dry & wet) is determined from Equation (3).

Table 1: Parameters of the Typical Case Study Vehicle

Parameter	Value
Power of engine (P)	140 Hp
Transmission Efficiency (η)	0.95
Vehicle Mass (m)	1180 Kg
Mass on Tractive Axle (m_{ta})	708 Kg
Roadway Adhesion (μ)	Dry = 1 Wet = 0.8
Air Density (ρ)	1.2256 Kg/m ³
Air Drag Coefficient (C_D)	0.3
Altitude Factor (C_h)	1
Frontal Area (A)	2.14 m ²
Rolling Coefficient	$C_r = 1.25$ $c_2 = 0.0328$ $c_3 = 4.575$

Table 2 demonstrates the different values of t_T , t_L , t_S and t_c for the case study vehicle. Depending on the roadway surface condition (wet or dry), the driver can accept/reject the offered gap size by comparing to the corresponding critical gap value (t_c).

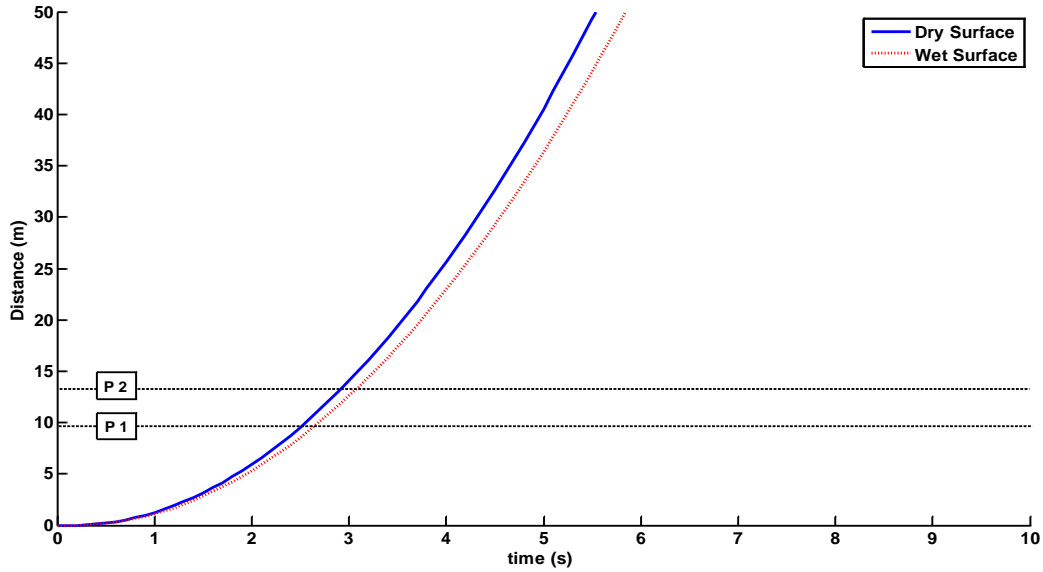

Figure 6: The time-space diagram of the typical case study vehicle

Table 2: The Mean Parameters Values for Test Vehicle

Time (s)	Conflict point	Dry	Wet
Travel time (t_T)	P1	2.3	2.6
	P2	2.8	3.1
Clear Vehicle time (t_L)	P1	0.6	0.7
	P2	0.5	0.6
Buffer of Safety time (t_S)	P1	1.0	2.3
	P2	0.8	2.3
Critical Gap time (t_c)	P1	3.9	5.5
	P2	4.1	5.9

It should be mentioned that by changing the vehicle engine power (i.e. by choosing another vehicle model or type), the travel time values will be affected minimally (the same for the buffer of safety value). This is because the dominant factor in computing the tractive force for low vehicle speeds and short distances (as is the case here) is the mass of the vehicle on the tractive axle (kg) and the coefficient of roadway adhesion (also known as the coefficient of friction). In the case of heavy-duty trucks and buses, however, considerable differences will be observed. The effect of these vehicles on gap acceptance behavior is an area of research that requires further investigation.

With the introduction of vehicle-to-infrastructure (V2I) communication it may be possible for the traffic signal controller to receive information on the vehicle make, mass, number of passengers. This information can then be used to provide customized critical gaps that are vehicle, roadway, and weather specific. The proposed modeling framework allows for incorporating new advanced in-vehicle technologies to assist drivers with gap acceptance decisions (i.e. accept or reject a gap).

AGENT-BASED MODEL VALIDATION

In comparing the two proposed models (traditional model and proposed model), the Success Rate factor (SR) is used as a criteria of comparison to show the superiority of a model on the other. The SR is defined as the percentage of observations with acceptance/rejection outcomes that are identical to data field responses. The model with the largest SR is a better model. In computing the SR for the Statistical model, the probability of accepting a gap was computed for each of the observations using the explanatory variables and rounding the response to 0 or 1 (it is rounded to 0 if the resulted probability is below 50% and rounded to 1 if it is equal or above 50%) and compared to the field observed response binary choice. Regarding the agent-based model, the SR is computed by comparing the acceptance/rejection decision to the observed decision based on the offered gap size and the corresponding critical gap value.

For model validation, the proposed approach is applied to two different datasets. The first dataset is for the Christiansburg intersection (shown in Figure 1) and the second dataset is taken from a published paper for Yan and Radwan in 2008 [28]. In their study Yan and Radwan investigated the influence of driver sight distance on left turn gap acceptance behavior. Yan and Radwan [28] used as a case study the intersection of Rouse Lake Rd. and E. Colonial Drive located in Orange County in Orlando, Florida. This intersection has four level approaches at a 90° angle and a protected/permitted left turn signal phase for the major road, as shown in Figure 7. The second dataset consisted of a total of 1,485 gap decisions from a total of 323 left turning movements recorded in dry conditions. The average waiting time of 7.6 s is assumed in this case given that the wait time was not included in the dataset. The results of the SR values for the two datasets are summarized in Table 3.

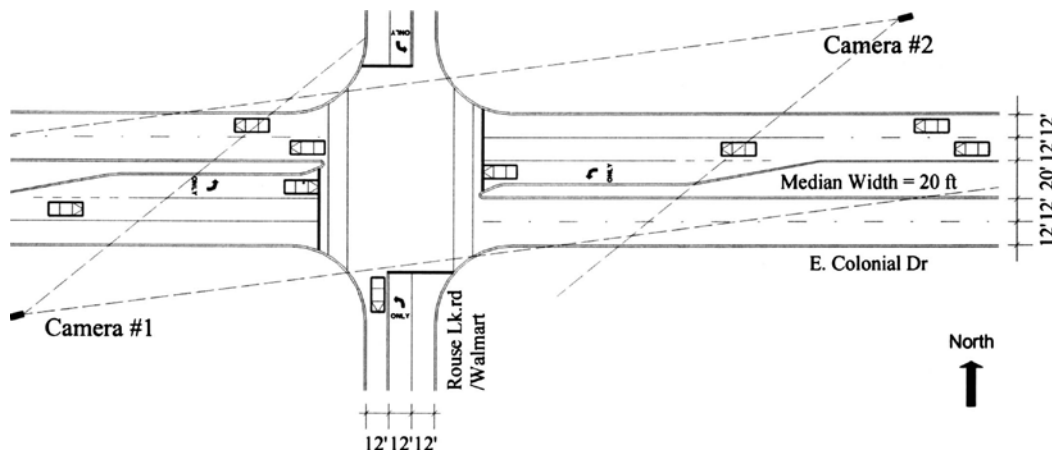

Figure 7: The intersection of Rouse Lk. Rd and E. Colonial Dr, Orlando, Florida (source [28])

Table 3: Model Success Rates for Accepted and Rejected Gaps

Measurements	Christiansburg Intersection (1 st dataset)		Orlando Intersection (2 nd dataset)	
	Statistical Model	Agent-based Model	Statistical Model	Agent-based Model
SR1 (% success for estimating observed accepted gaps)	64%	94%	49%	94%
SR2 (% success for estimating observed rejected gaps)	98%	88%	98%	88%
SR3 (% success for estimating all observed gaps)	95%	89%	87%	90%

As demonstrated in Table 3, the SR1 value for the agent-based model is greater than the statistical model for both datasets. For the SR3 value (weighted mean of accepted and rejected gaps), the statistical model is better in the first dataset but the agent-based model is better in the second dataset which demonstrates the key strength of the proposed agent-based model and that is its transferability to other locations. Although, the statistical model seems better in some aspects, the agent-based model is recommended because it provides a good balance between accepted and rejected gap success rates, which are around the 90%. The errors produced by the model were typically related to drivers not accepting a valid gap either because they were distracted or because they were unable to judge the size of the gap adequately.

SUMMARY AND CONCLUSIONS

Agent-based modeling is evolving as a promising approach for modeling complex systems composed of interacting, autonomous units (i.e. agents). Agents have behaviors, often described by simple rules, and interactions with other agents, which in turn influence their behaviors. There are a growing number of agent-based applications in a variety of fields and disciplines including the transportation field that have been reported in the literature. The paper presents a novel application of an agent-based modeling framework for modeling driver gap acceptance behavior. The research presents a “Reactive-Driving” agent-based algorithm for modeling gap acceptance driving behavior. The proposed reactive-driving agent is developed using 301 field observed accepted gaps collected from a signalized intersection with a permissive left turn movement. The use of accepted gaps was required because we can only estimate the travel time and buffer of safety if they accept the gap. The proposed model is considered as a mix between traditional and reactive methods for decision making.

The model uses sensing information together with vehicle and driver characteristics to estimate a driver-specific critical gap. Thereafter, the agent can decide either to accept or reject the offered gap by comparing it to a driver-specific critical gap. If the offered gap is greater than the driver-specific critical gap the gap is accepted otherwise it is rejected.

A vehicle dynamics model is then used to estimate the travel time required to reach the conflict point, the time needed to clear the length of the vehicle and an additional time used by the driver as a buffer of safety. The reactive-driving agent model could be considered as a driver-vehicle interaction model that models differences between drivers by considering the vehicle capability and the driver-specific buffer of safety time. Consequently, an aggressive driver will accelerate faster and require a smaller buffer of safety when compared to the average driver. The

study after that compares the validation of the proposed agent-based model results to the statistical model using the success rates (SR) criteria on two different datasets, and it is found that the agent-based model is more consistent in its SR values (around 90%) and it is better than the statistical model. A key advantage of the proposed modeling approach is that it is easily transferable and does not require extensive calibration to local conditions. State-of-the-practice statistical models are less transferrable given that they do not capture the underlying phenomena associated with gap acceptance behavior.

One of the applications of the proposed modeling approach is to capture inclement weather impact on gap acceptance behavior using the cooperation of the agent system with different control agencies. This storage device in the agent-based model algorithm is responsible for collecting all the information related to previous gap acceptance behavior for the same driver. The database information contains the driver decision (accept or reject) and all the corresponding parameters including the vehicle characteristics, intersection properties, travel time needed and corresponding weather condition. In addition, the agent inside the vehicle will receive weather information from a station agency, in order to relate the impact of weather to gap acceptance behavior. All these information are used to build the driver decision making pattern for different gap acceptance scenarios using a supervised machine learning process that is used to develop a driver decision support system. The system provides the driver with appropriate guidance for gap acceptance/rejection for intersection crash prevention. It is anticipated that this research will contribute in the future of intelligent transportation systems (ITSs), connected vehicle technology systems, and vehicle to infrastructure communications.

As with any study further research can be conducted in a number of areas. First, given the modeling framework it would be interesting to extend the model to include heavy-duty trucks and buses. Second, the modeling framework should be tested at other locations for different maneuvers.

ACKNOWLEDGEMENTS

The authors acknowledge the valuable input from Dr. Roemer Alfelor and Dr. David Yang of the Federal Highway Administration, Daniel Krechmer of Cambridge Systematics, Inc., Dr. Shereef Sadek at Virginia Tech Transportation Institute (VTTI) for providing input on the model and Prof Essam Radwan at University of Central Florida for providing the validation dataset. Finally, the authors also acknowledge the financial support provided by the FHWA and the Mid-Atlantic University Transportation Center in conducting this research effort.

REFERENCES

- [1] W. Arthur, S. Durlauf, and D. Lane, "The Economy as an Evolving Complex System II, SFI Studies in the Sciences of Complexity," *Addison-Wesley: Reading, MA*, 1997.
- [2] A. Charania, J. R. Olds, and D. DePasquale, "Sub-orbital Space Tourism Market: Predictions of the Future Marketplace Using Agent-based Modeling," *SpaceWorks Engineering, Inc.: Atlanta, GA*, 2006.
- [3] A. Troisi, V. Wong, and M. Ratner, "An agent-based approach for modeling molecular self-organization," *Proc Natl Acad Sci* 102(2), pp. 255-260, 2005.
- [4] A. Boukerche, R. B. Machado, K. R. L. Jucá, and J. B. M. Sobra, "An agent-based and biological inspired real-time intrusion detection and security model for computer network operations," *Comp Commun* 30(13), pp. 2649-2660, 2007.
- [5] L. Preziosi, "Cancer Modelling and Simulation," presented at the Chapman and Hall/CRC, Boca Raton, FL., 2003.

- [6] T. Emonet, C. M. Macal, M. J. North, C. E. Wickersham, and P. Cluzel, "AgentCell: A digital single-cell assay for bacterial chemotaxis," *Bioinformatics* 21(11), pp. 2714-2721, 2005.
- [7] B. Chen and H. H. Cheng, "A Review of the Applications of Agent Technology in Traffic and Transportation Systems," *IEEE Transactions on Intelligent Transportation Systems*, vol. 11, pp. 485-497, 2010.
- [8] S. Ossowski, J. Cuenca, and A. Garcia-Serrano, presented at the Social Structure as a Computational Co-ordination Mechanism in Societies of Autonomous Problem-solving Agents. Intelligent Agents V. Springer-Verlag, 1999.
- [9] D. A. Roozmond, "Using intelligent agents for urban traffic control systems," presented at the Proceedings of the 11th Mini-Euro Conference on Artificial Intelligence in Transportation Systems and Science, Helsinki University of Technology, Espoo, Finland, 1999.
- [10] K. Dresner and P. Stone, "Multiagent traffic management: A reservation-based intersection control mechanism," presented at the The Third International Joint Conference on Autonomous Agents and Multiagent Systems, New York, New York, USA, 2004.
- [11] K. Dresner and P. Stone, "Multiagent traffic management: A protocol for defining intersection control policies," The University of Texas at Austin, Department of Computer Sciences, AI Laboratory 2004.
- [12] K. Dresner and P. Stone, "Multiagent Traffic Management: An Improved Intersection Control Mechanism," presented at the The Fourth International Joint Conference on Autonomous Agents and Multiagent Systems, Utrecht, The Netherlands.
- [13] K. Dresner and P. Stone, "Multiagent Traffic Management: Opportunities for Multiagent Learning," presented at the K. Tuyls, et al, editors, LAMAS, Lecture Notes In Artificial Intelligence, Springer Verlag, Berlin, 2005.
- [14] X. Zou and D. Levin, "Vehicle-based intersection management With intelligent agents," presented at the ITS America Annual Meeting Proceedings, 2003.
- [15] A. L. C. Bazzan, "A Distributed Approach for Coordination of Traffic Signal Agents," in *Autonomous Agents and Multi-Agent Systems*, S. S. B. Media, Ed., ed, 2005, pp. 131–164.
- [16] H. Dia and H. Purchase, "Modelling the impacts of advanced traveller information systems using intelligent agents," presented at the Road and Transport Research 8 (3), ARRB Transport Research Ltd., Vermont South, Victoria, Australia, 1999.
- [17] H. Dia, "A conceptual framework for modelling dynamic driver behaviour using intelligent agents," presented at the the 6th International Conference on Applications of Advanced Technologies in Transportation Engineering, Singapore, 2000.
- [18] R. Rossetti, S. Bampi, R. Liu, D. V. Vleit, and H. Cybis, "An agent-based framework for the assessment of drivers decision-making," presented at the Proceedings of the 2000 IEEE Intelligent Transportation Systems, Dearborn, MI, USA.
- [19] J. Wahle, A. L. C. Bazzan, F. Klugl, and M. Schreckenberg, "Anticipatory traffic forecast using multi-agent techniques," In: *Helbing, D., Hermann, H., Schreckenberg, M., Wolf, D. (Eds.)*, vol. Traffic and Granular Flow, Springer, Heidelberg, 1999.
- [20] H. Rakha, K. Ahn, and K. Moran, "INTEGRATION Framework for Modeling Eco-routing Strategies: Logic and Preliminary Results," " presented at the 90th Transportation Research Board Annual Meeting, Washington D.C., 2011.

- [21] J. Hernandez, J. Cuena, and M. Molina, "Real-time traffic management through knowledge-based models: the TRYS approach. Tutorial on Intelligent Traffic Management Models," presented at the Proceedings of the 11th Mini-Euro Conference on Artificial Intelligence in Transportation Systems and Science, Helsinki University of Technology, Espoo, Finland, 1999.
- [22] H. Dia, "An agent-based approach to modelling driver route choice behaviour under the influence of real-time information," *Transportation Research Part C* pp. 331-349, 2002.
- [23] X. Jin, M. Itmi, and H. Abdulrab, "A cooperative multi-agent system simulation model for urban traffic intelligent control," presented at the Proceedings of the 2007 Summer Computer Simulation Conference, Society for Computer Simulation International, , San Diego, CA, 2007.
- [24] TRB, "HCM :Highway Capacity Manual 2000," presented at the Transportation Research Board, 2000.
- [25] M.S. Raff and J.W. Hart: "A volume warrant for urban stop signs." Eno Foundation for Highway Traffic Control, Saugatuck, Connecticut, USA, 1950.
- [26] B.Greenshields, D.Schapiro, and E.Ericksen, "Traffic Performance at Urban Street Intersections," Yale Bureau Of Highway Traffic 1947.
- [27] J. M. Mason, Fitzpatrick, K. and Hardwood, D.W., "Field observations of truck operational characteristics related to intersection sight distance," *Transp. Res. Record 1280, Transportation Research Board, Washington, D.C.*, pp. 163-172, 1990.
- [28] X. Yan, and Radwan,E., "Influence of Restricted Sight Distances on Permitted Left-Turn Operation at Signalized Intersections," *Journal of Transportation Engineering ASCE*, vol. 134, February 2008.
- [29] M. M. Hamed and S. Easa, "Disaggregate Gap-Acceptance Model for Unsignalized T-Intersections," *Journal of Transportation Engineering*, vol. 123, February 1997.
- [30] P. Solberg and J. C. Oppenlander, "Lag And Gap Acceptances At Stop-Controlled Intersections," *Highway Research Board, Washington, D.C.*, pp. 58-69, 1966.
- [31] P. A.M.Ehlert and L. J.M.Rothkrantz, "Microscopic traffic simulation with reactive driving agents," presented at the IEEE Intelligent Transportation Systems Conference Proceedings, Oakland (CA) USA, 2001.
- [32] T. Wittig, "ARCHON: an architecture for multi-agent systems," presented at the Ellis Horwood Limited, England, 1992.
- [33] A. S. Rao and M. P. Georgeff, "BDI Agents: From Theory to Practice," presented at the Proceedings of the 1st International Conference on Multi-Agent Systems (ICMAS-95), San Francisco, USA, 1995.
- [34] H. Rakha, M. Snare, and F. Dion, "Vehicle dynamics model for estimating maximum light-duty vehicle acceleration levels," *Transportation Research Record*, vol. n 1883, pp. 40-49, 2004.
- [35] H. Rakha, I. Lucic, S. H. Demarchi, J. R. Setti, and M. Van Aerde, "Vehicle dynamics model for predicting maximum truck acceleration levels," *Journal of Transportation Engineering*, vol. 127, pp. 418-425, 2001.

GAME THEORY ALGORITHM FOR INTERSECTION-BASED COOPERATIVE ADAPTIVE CRUISE CONTROL (CACC) SYSTEMS

Ismail H. Zohdy

Center for Sustainable Mobility, Virginia Tech Transportation Institute
3500 Transportation Research Plaza, Blacksburg, VA 24061
Phone: (540) 231-1506 Fax: (540) 231-1555
izohdy@vt.edu

Hesham A. Rakha

Charles E. Via, Jr. Department of Civil and Environmental Engineering
3500 Transportation Research Plaza, Blacksburg, VA 24061
Phone: (540) 231-1505 Fax: (540) 231-1555
hrakha@vt.edu

ABSTRACT

The paper develops a heuristic optimization algorithm for automated vehicles (equipped with cooperative adaptive cruise control CACC systems) at uncontrolled intersections using a game theory framework. The proposed system models the automated vehicles as reactive agents interacting and collaborating with the intersection controller (manager agent) to minimize the total delay. The system is evaluated using a case study considering two different intersection control scenarios: a four-way stop control and the proposed intersection controller framework. In both scenarios, four automated vehicles (a single vehicle per approach) were simulated using a Monte Carlo simulation that was repeated 1000 times. The results show that the proposed system reduces the total delay relative to a traditional stop control by 35 seconds on average, which corresponds to an approximately 70 percent reduction in the total delay.

INTRODUCTION

Every year in the United States, about six million traffic accidents occur on US roads where more than 90 percent of these accidents are a result of human distraction and/or misjudgment [1]. Consequently, the idea of an automated driving environment has been studied for decades to reduce the number of crashes and enhance the transportation system mobility.

In one of the early automation trials, the USDOT established the Automated Highway System (AHS) program for the purpose of increasing the efficiency (reducing delay and enhancing safety) of traffic networks using automated vehicle control [2]. Although the AHS program was not able to continue, it is considered the basis of many driver assistant systems in the market today.

After the development and deployment of the USDOT Connected Vehicle initiative [3], the enhancement of the current driver assistance systems has become an expected step towards achieving better mobility and safety. Accordingly, the concept of Cooperative Adaptive Cruise Control (CACC) systems has been introduced as an advanced generation for the traditional cruise control. In the CACC system, vehicles have the ability to sense and communicate with other vehicles through vehicle-to-vehicle (V2V) and vehicle-to-infrastructure (V2I) communication. After fusing all data sources, vehicles make decisions with regards to acceleration, deceleration, or maintaining their current speed. The basic idea of the system is to assist the driver by controlling the speed of the vehicle; however it leaves the maneuver responsibility to the driver.

It is anticipated in the future that many (or most) of the vehicles will be fully automated; thus the movements of these vehicles should be optimized. The new CACC concept is introduced to highways, sometimes in dedicated lanes, to reduce the gaps between vehicles using communication technology. However, a few research efforts have considered the use of CACC at intersections in order to enhance vehicle movement, reduce delay, and reduce fuel consumption levels.

LITERATURE REVIEW

Very limited research efforts have studied the impact of advanced cruise control systems on intersection operations in comparison to the wealth of literature dedicated to highway operations. Most of the studies directly related on CACC at intersections have focused on fuel consumption and emissions impacts (e.g. [4]). There are a few research efforts focused on the impact of optimal speed advisory for drivers comparing to the design of the signal timing of the traffic signals [5, 6].

Regarding research efforts directly related to CACC applications, Malakorn and Park (2010) evaluated the performance of intelligent traffic signal control systems integrated with CACC systems to traditional intersection control [7]. The goal of this system was to reduce the environmental impacts of vehicles in the vicinity of intersections by minimizing vehicle acceleration levels. The procedure estimates vehicle emissions using the VT-Micro-model [8]. Under the connected vehicles (CV) environment, Lee and Park [9] created a Cooperative Vehicle Intersection Control (CVIC) system that enables cooperation between vehicles and infrastructure for effective intersection operations and management.

In general, the literature related to CACC is limited; especially the studies of CACC capabilities at intersections. The CACC controller can better foresee problems, enabling the vehicle to be safer and faster in response to various stimuli. However, extensively exploring the CACC impact on delay and how it could be used as a tool for optimizing the movements of vehicles at intersections is limited to only a few researchers. It could be stated that none of the previous approaches used an explicit optimization algorithm for reducing delay (minimizing travel time) and in some cases it was simply expressed as functions of acceleration/deceleration levels.

STUDY OBJECTIVE AND PAPER LAYOUT

The purpose of this study is to develop a heuristic optimization algorithm for controlling vehicle movements of vehicles equipped with CACC systems at uncontrolled intersections using "Game Theory Decision" field theory. The vehicles are modeled as agents interacting with the intersection controller (manager agent) and obeying the optimum decision made by the intersection controller. In other words, the vehicles collaborate in a form of a "Cooperative Game" with the controller installed at the intersection. The main principle of this research is to employ the communication technologies with advanced vehicle capabilities to replace the usual state-of-the-practice control systems at intersections (e.g. stop sign, yield signs, etc.).

In terms of the paper layout, initially a description of the proposed multi-agent system is presented. Subsequently, the built-in simulation process using game theory is presented and the testing of the optimization algorithm is then discussed. Finally, the conclusions of the paper and future research directions are discussed.

PROPOSED MULTI-AGENT MODELING LAYOUT

The capabilities of an intelligent agent make it possible to control various types of vehicles with different driving behavior. For the case of automated vehicles, agent-based modeling is considered the most appropriate approach as was suggested in several literature sources [10, 11]. Here we propose the use of agent-based modeling of CACC-equipped vehicles as the agents have two main features: (1) they are at least to some extent capable of autonomous actions or decisions and (2) they are capable of interacting with other agents through cooperation, coordination and negotiation [12].

The proposed multi-agent system (MAS) consists of two types of agents: reactive agents (vehicles equipped by CACC) and a manager agent (intersection controller). The main idea of the proposed system is that the manager agent communicates with the reactive agents in the intersection study zone (ISZ) and determines the optimum movements for each reactive agent based on a "Game Theory Decision Framework". The ISZ is the zone area around the intersection where the reactive agents begin to exchange information with the manager agent. The ISZ in this research 200 m upstream of the intersection to ensure that vehicles have sufficient time to receive and respond to the information received.

The proposed layout for the MAS assumes that all agents in the ISZ are interacting, communicating and exchanging information for the common benefit using some form of communication (e.g. Dedicated Short Range Communication (DSRC)). The global benefit is defined as reducing the total delay while ensuring no vehicle collisions occur. The reason for modeling the collaboration between agents is to overcome any selfish behavior by any vehicle or in other words to seek the global benefit for all vehicles in the ISZ. Therefore, the main task for the manager agent is to determine the optimum speed for each reactive agent at each time step by processing the input data through a real-time simulation. The MAS layout consists of three main components for controlling the movements of reactive agents in the ISZ: Input, Data processing and Output.

The input data for the manager agent consists of: intersection characteristics, weather station input and reactive agent input. The intersection characteristics contain the speed limit of the intersection and number of lanes of each approach. The weather station provides the instantaneous weather condition to take into account the roadway surface condition (dry or wet) in simulating the reactive agent movements. At each time step, all reactive agents in the ISZ report their physical characteristics, current speed, location and acceleration to the manager agent. All input information is received by the manager agent then processed and optimized using a game theory decision process. For the purpose of this research, a simulation tool was developed using Matlab. Figure 1 illustrates the layout of the proposed CACC multi-agent system.

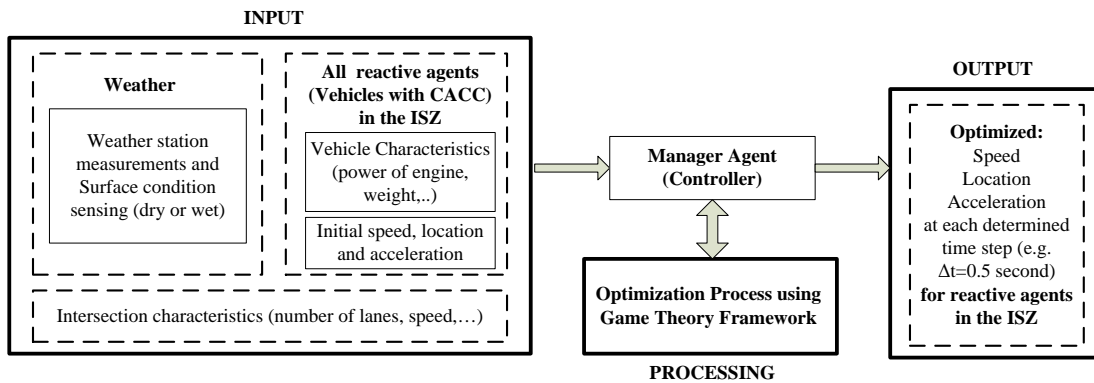

Figure 8: The layout of the proposed MAS for equipped vehicles at uncontrolled intersections

PROPOSED REAL-TIME SIMULATION FOR CACC-EQUIPPED VEHICLES

This section describes the state-of-art simulation test bed that was developed to model the intersection controller. The research presented here is considered a first step in developing a fully automated intersection vehicle controller. In general, the simulation algorithm computes the optimum location, speed and acceleration of vehicles to ensure that no conflicts occur while at the same time minimizing the total intersection delay each time step (e.g. 0.5 sec). The total delay is defined by the summation of the delay experienced by each vehicle at each time step.

The proposed software is considered as a novel tool for optimizing the movement of automated vehicles at intersections; however, it has some limitations and assumptions. First, we assume a market penetration of 100% of CACC-equipped vehicles. Second, all drivers/vehicles

in the ISZ are assumed to follow the recommendations made by the intersection controller to achieve the global profit. Last, only one speed profile, i.e. one vehicle (the most critical one), is adjusted (optimized) each time step.

It should be mentioned that the vehicle dynamics (acceleration and deceleration) models are part of the simulation software. The dynamics models take into account the tractive and resistance forces (referred to the literature [13]) acting on vehicles at each time step. Consequently, the simulation process reflects the physical characteristics (power of engine, mass, etc.) and the weather condition (wet or dry) affecting the movements of vehicles.

At each time step of simulation, the existing vehicles in the ISZ are determined and thereafter the built-in simulation uses a heuristic optimization process divided into two main stages. The stages are: 1) calculate the Conflict Zone Occupancy Time (CZOT) for each conflict area, 2) conduct a Game Theory Optimization, as will be explained in more detail in the following sub-sections.

Calculate the Conflict Zone Occupancy Time in Conflict Areas

A conflict point in the intersection is a point that can be occupied by two different crossing vehicles during the same time interval. We introduce the term **Conflict Zone Occupancy Time (CZOT)** in the optimization process. The CZOT is the time interval where the two intersecting vehicles will be occupying the same conflict area. The simulation software uses the input information to simulate the trajectory of the vehicles; therefore estimates the time needed to enter and leave the conflict zone. The simulation software assumes that all vehicles will accelerate to the maximum speed (if their speed is less than the maximum) as an “initial decision” to reduce the total travel time for each vehicle. If the estimated CZOT value is positive (>0), it is an indication that by accepting the initial decision for both intersecting vehicles, a collision would occur. Alternatively, if CZOT is equal to zero (or less) that means the intersecting vehicles will not be conflicting with each other and it is safe to accept the initial decision.

For illustrating purposes, for a four-legged intersection we would have four conflict zones (assuming on through traffic on each approach), as shown in Figure 2 (a). Consequently, the CZOT value for each conflict area, CZOT1, CZOT2, CZOT3 and CZOT4 can be computed. Thereafter, the CZOT plot is drawn as shown in Figure 2 (b) where each rectangle illustrates the conflict occupancy time for each vehicle. In the example, we can observe that CZOT1, CZOT2 and CZOT4 have positive values (i.e. there is a common time interval between the two intersecting vehicles). Consequently, we need to adjust the vehicle trajectories in order to avoid a collision with the intersecting vehicles. On the other hand, the CZOT3 value is equal to zero as the two intersecting vehicles occupy the conflict zone at different time intervals.

As mentioned before, the built-in simulation selects only one vehicle to modify its trajectory each time step (i.e. 0.5 second). Therefore the next step is to select the appropriate vehicle to adjust its trajectory.

Game Theory Optimization Process

Various models that incorporate concepts from Game Theory are described in many transportation related literature [14-17]. Interaction and collaboration are essential aspects in the dynamic multi-agent systems (MASs); consequently, game theory provides powerful tools for analyzing those types of transport systems.

A game of strategy is defined as the game where each player is trying to choose the best strategy to maximize the total benefit [18]. In cooperative games (one of the types of the strategy games), the pay-off (benefit) for each potential group can be obtained by the coalitional of its

members (or players). The challenge of the cooperative game is to allocate the pay-off (benefit) among the players in some fairway. Consequently, collaborating with all CACC-equipped vehicles together with the intersection controller, using communication technology, could be formulated in a cooperative game framework. Defining a game requires identification of the players, their choices (strategies) and their objectives as will be described in the following section.

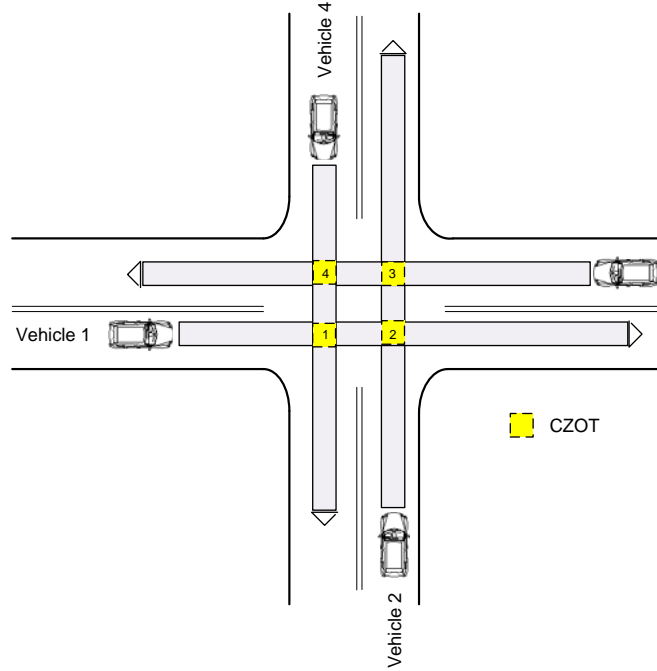

(a)

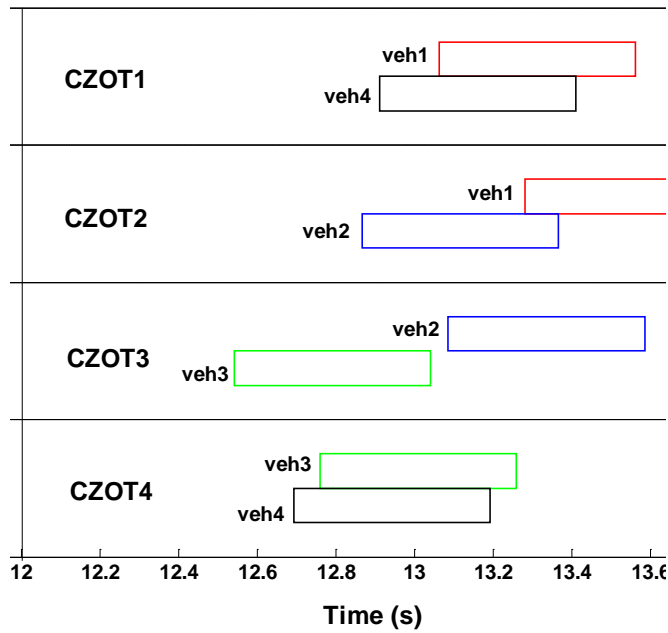

(b)

Figure 9: Conflict Zone Occupancy Time (CZOT) output example

ELEMENTS OF THE GAME (DESCRIBING A GAME)

Game theory provides a framework for modeling interactions between groups of decision-makers when individual actions jointly determine the outcome [18]. The proposed cooperative game framework in this research is entitled: CACC-CG (**C**ooperative **A**daptive **C**ruise **C**ontrol - **C**ooperative **G**ame). The CACC-CG represents the decision process of the built-in simulation software to optimize the movement of automated vehicles at intersections. The proposed CACC-CG is considered a decision process that is repeated at each time step of the simulation. The CACC-CG cooperative game consists of the following elements: players (s), actions (A), information (I), strategies (S), pay-offs (U), outcomes (O) and equilibrium (π).

Each player's goal is to choose the best action in order to maximize his/her utility. The players in the CACC-CG are the manager agent and all reactive agents at each time step. Actions are the choices that each player can make. For the manager agent, the action is to select one reactive agent for optimizing its movement each time step while other vehicles maintain their current state until the next time step. Reactive agents have three possible actions: decelerate, accelerate or maintain their current speed. It is assumed the information set is available for all players during the game decision process. In other words, the information is symmetric and certain for all players using communication technology (DSRC).

The player's strategy is simply the set of actions that could provide the maximum profit. In other words, the action set includes all actions that minimize the total delay and ensure safe maneuvers for all agents at the intersection.

Furthermore, Pay-off is the expected benefit or utility that the player will receive after all players took their decisions and the game has been played. In the CACC-CG, the pay-off is determined based on the actions of the players and it is proposed to be formulated as a Utility function. It is assumed in this framework that the optimum decision taken by the players would be the action set that lead to the minimum utility function (conflict zone and delay minimization). Consequently, the players follow the maximin principle. The value of utility function depends on the distance remaining to the intersection relatively to the needed stopping sight distance for each vehicle. Generally, the utility value is considered as the summation of the total CZOT values and the total delay due to the actions of manager agent (i) and any selected reactive agent (j). However, if the distance remaining for a vehicle to the intersection is less than minimum stopping sight distance, its utility value is set to be an infinity value. In other words, if a vehicle does not have the option other than decelerating to complete stop, this vehicle will not be a part of the optimization process as presented in Equation (1).

$$U_{i,j} = \begin{cases} \sum_{p=1}^P CZOT_{i,j} + \sum_{i=1}^N D_{i,j} & ; \text{ if } X_j > SSD_j \\ \infty & ; \text{ if } X_j < SSD_j \end{cases} \quad (7)$$

Where, i is the action taken by the manager agent; j is the action taken by the reactive agent; $U_{i,j}$ is the utility value corresponding to the action set (i, j), P is the total number of conflict points; $CZOT_{i,j}$ is the conflict zone occupancy time value (explained previously) corresponding to the action set (i, j); X_j is the current distance to the intersection for vehicle j ; SSD_j is the minimum stopping sight distance to the intersection for vehicle j ; N is the total number of reactive agents (vehicles) existed in the current time step; and $D_{i,j}$ is the delay value for each reactive agent also corresponding to the action set (i, j).

Outcome is a set of resulted elements after the game is played out. Consequently, the outcome of the proposed game is simply: vehicle trajectories (acceleration, deceleration or constant speed) for a chosen vehicle that would lead to the least utility function.

For the equilibrium, once the players have settled on strategies that satisfy all them, this condition is called the Nash equilibrium (named after John Forbes Nash) [18]. Some literature defines simply the equilibrium as the best decision by the player given that the other players already made their decision[18].

In the general case, the proposed game CACC-CG consists of a sequence of turns that need not be all the same; therefore it could be taken as the type of "Extensive Form" games. This kind of games is best represented by a game tree. A game tree is a connected graph which contains no circuit. The game tree form of the CACC-CG is presented in Figure 3(a). One way to solve an extensive game is to convert it to a normal-form game. The normal form is a matrix, each column is defined by a strategy for player 1 and each row of which is labeled with a strategy for player 2 as shown in Figure 3(b).

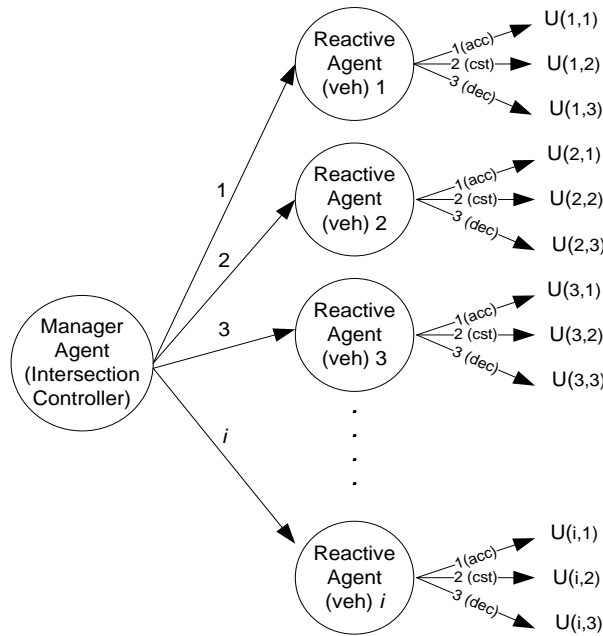

(a)

		Manager Agent Action (i)				
		Reactive Agent 1	Reactive Agent 2	Reactive Agent 3	Reactive Agent i
Reactive Agent Action (j)	Accelerate (1)	U(1,1)	U(2,1)	U(3,1)	U(i,1)
	Constant speed(2)	U(1,2)	U(2,2)	U(3,2)	U(i,2)
	Decelerate(3)	U(1,3)	U(2,3)	U(3,3)	U(i,3)

(b)

Figure 10: The extensive form (game tree & normal-form) for the CACC-CG proposed game

In summary, the game is simply to form a pay-off table –as Figure 3(b)- for the intersection controller (manager agent) and the vehicles (reactive agents) in the ISZ at each time step. The pay-off table shows the utility matrix of each action combination between the manager agent and each reactive agent. Consequently, by choosing the minimum utility value the best choice for all players would be decided: “the maximin principle”. In other words, the equilibrium status could be achieved at each time step by selecting the best action combination between players in the proposed cooperative game CACC-CG. Consequently, the outcome of the optimization process that would be an optimum decision (accelerate, decelerate or constant speed) for a selected vehicle and accordingly the vehicle would follow the optimum decision. The process of the proposed optimization framework is heuristically repeated at each time step till the end of simulation.

SYSTEM TESTING

In order to test the proposed system, two different intersection control scenarios for a case study intersection are considered. The first scenario uses a four-way stop control system while the second scenario applies the proposed game theory intersection manager. The case study intersection consists of four single lane approaches, as in Figure 2 (a). Standard lane widths of 3.5 meters are considered with approach speed limits of 35 mph. For illustration purposes, we modeled a Toyota Prius 2010 model with an engine power of 134 Horse Power (Hp). This vehicle is similar to the tested vehicle in the Google Driverless experiment [19]. The study considered a single vehicle arrival on each approach considering the proposed intersection manager and an all-way stop controlled intersection. For both scenarios, the entrance time, speed, and acceleration of each vehicle were randomly generated. The system was then modeled considering a time step (Δt) of 0.5 s. The total delay was computed for each run considering the two intersection control scenarios. The total delay was computed for all four automated vehicles. This procedure was repeated 1000 times using a Monte Carlo simulation and the total delay time was recorded for each simulation. Figure 4 shows the total delay variation for the 1000 simulations for both intersection control strategies.

The results demonstrate that the proposed framework is giving less total delay time comparing to the stop sign control scenario. The average total delay time for the proposed scenario is approximately 19 seconds and for the stop sign control is 54 seconds. Thus, for the case of only four crossing vehicles, the proposed system reduces the total delay more than the traditional stop control by 35 seconds on average and obviously the total delay reduction would enlarge by having more vehicles crossing the intersection.

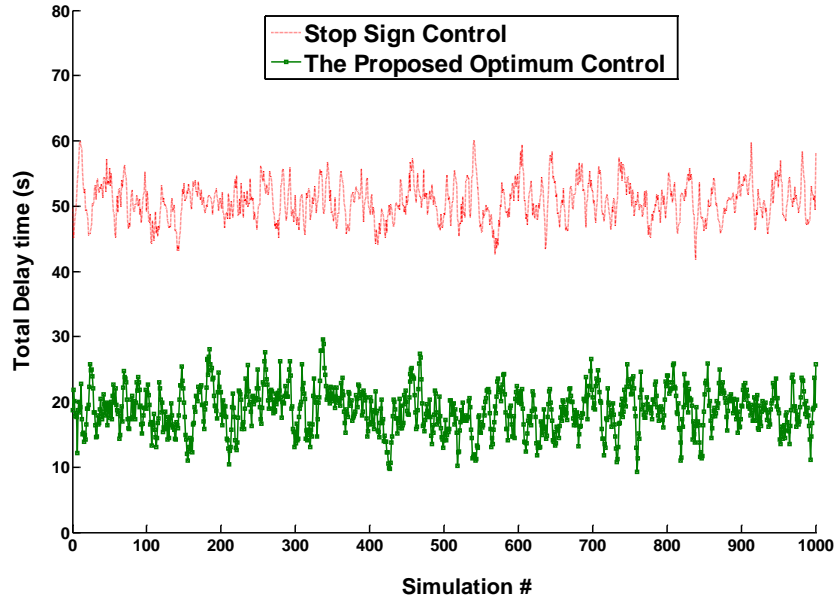

Figure 11: Total Delay comparison between Stop Sign control and proposed optimization control using game theory

CONCLUSIONS AND FUTURE WORK

The research presented in this paper developed an innovative algorithm for optimizing the movement of vehicles at intersections within a CACC framework. The proposed framework uses game theory to ensure that no crashes occur while minimizing the intersection delay. The proposed framework assumes communication between vehicles and the intersection infrastructure to control the movements of the reactive agents approaching the intersection study zone (ISZ). A real-time simulation tool is developed that would be loaded onto an intersection controller to control the vehicle movements. The simulation determines the vehicles currently in the ISZ and then estimates their trajectories based on their current state. Thereafter, the optimization process begins by forming a pay-off table for what would be the output in case of any action taken by the controller or the vehicles. Consequently, the intersection controller would advise the vehicle (using communication) to the best action. This process is repeated heuristically at each time step for the duration of the simulation (i.e. all vehicles traverse the intersection). The proposed work serves as an initial step towards the development of agent-based CACC intersection control systems. The research results demonstrate the promising potential benefits of such a system over conventional state-of-the-practice intersection control systems. Further testing of the proposed system is recommended for typical intersection configurations under realistic traffic demand levels relative to alternative state-of-the-practice intersection control systems.

REFERENCES

1. NCSA, *National Center for Statistics and Analysis, Traffic Safety Facts 2009*, D.H. 811401, Editor. 2011: U.S. DOT, Washington, DC.
2. *US Department of Transportation Website*, <http://www.fhwa.dot.gov>, Accessed on November 10th 2011.

3. *Connected Vehicle Research program (IntelliDrive)*, http://www.its.dot.gov/connected_vehicle/connected_vehicle.htm, Retrieved July 11th, 2012.
4. Rakha, H. and R.K. Kamalanathsharma, *Eco-driving at Signalized Intersections using V2I Communication*. 14th International IEEE Annual Conference on Intelligent Transportation Systems, 2011.
5. Stevanovic, A., et al., *Optimizing traffic control to reduce fuel consumption and vehicular emissions: an integrated approach of VISSIM, CMEM, and VISGAOST*, in *The 88th Annual Meeting of the Transportation Research Board*. 2009.
6. Nishuichi, H. and T. Yoshii, *A study of the signal control for the minimization of CO2 emission*, in *Proceedings of the 12th World Congress on Intelligent Transport Systems*. 2005: San Francisco, CA.
7. Malakorn, K.J. and B.B. Park, *Assessment of Mobility, Energy, and Environment Impacts of IntelliDrive-based Cooperative Adaptive Cruise Control and Intelligent Traffic Signal Control*. IEEE International Symposium on Sustainable Systems and Technology, 2010.
8. Rakha, H. and K. Ahn, *Integration Modeling Framework for Estimating Mobile Source Emissions*. Transportation Engineering ASCE, 2004: p. 183-193.
9. Lee, J. and B.B. Park, *Development and Evaluation of a Cooperative Vehicle Intersection Control Algorithm under the Connected Vehicles Environment*. IEEE Transactions on Intelligent Transportation Systems, 2011.
10. Dia, H., *An agent-based approach to modelling driver route choice behaviour under the influence of real-time information*. Transportation Research Part C 2002: p. 331-349.
11. Dresner, K. and P. Stone, *Multiagent Traffic Management: Opportunities for Multiagent Learning*, in *K. Tuyls, et al, editors, LAMAS, Lecture Notes In Artificial Intelligence*. 2005: Springer Verlag, Berlin.
12. Chen, B. and H.H. Cheng, *A Review of the Applications of Agent Technology in Traffic and Transportation Systems*. IEEE Transactions on Intelligent Transportation Systems, 2010. **11**: p. 485-497.
13. Rakha, H. and I. Lucic, *Variable power vehicle dynamics model for estimating maximum truck acceleration levels*. Journal of Transportation Engineering, 2002. 128(5): p. 412-419.
14. Xinhai, X. and X. Lunhui, *Traffic Signal Control Agent Interaction Model based on Game Theory and Reinforcement Learning*, in *International Forum on Computer Science-Technology and Applications*. 2009.
15. Martin, J.C. and C. Roman, *Hub location in the South-Atlantic airline market A spatial competition game*. Transportation Research Part A, 2003: p. 865–888.
16. Shyr, O. and M.-F. Hung, *Intermodal Competition with High Speed Rail- a Game Theory Approach*. Journal of Marine Science and Technology, 2010. 18(1): p. 32-40.
17. Laumonier, J., C. Desjardins, and B. Chaibdraa, *Cooperative Adaptive Cruise Control: a Reinforcement Learning Approach*, in *Autonomous Agents and Multiagent Systems (AAMAS)*. 2006.
18. Rasmusen, E., *Games and Information: An Introduction to Game Theory*. 1990: Basil Blackwell, Inc.
19. *The New York Times* <http://www.nytimes.com/2010/10/10/science/10google.html>, Retrieved May15th, 2011.

INTERSECTION MANAGEMENT FOR AUTONOMOUS VEHICLES USING ICACC

Ismail H. Zohdy

Center for Sustainable Mobility, Virginia Tech Transportation Institute
3500 Transportation Research Plaza, Blacksburg, VA 24061
Phone: (540) 231-1506 Fax: (540) 231-1555
izohdy@vt.edu

Raj K. Kamalanathsharma

Center for Sustainable Mobility, Virginia Tech Transportation Institute
3500 Transportation Research Plaza, Blacksburg, VA 24061
Phone: (540) 231-1506 Fax: (540) 231-1555
izohdy@vt.edu

Hesham A. Rakha

Charles E. Via, Jr. Department of Civil and Environmental Engineering
3500 Transportation Research Plaza, Blacksburg, VA 24061
Phone: (540) 231-1505 Fax: (540) 231-1555
hrakha@vt.edu

ABSTRACT

Recently several artificial intelligence labs have suggested the use of fully equipped vehicles with the capability of sensing the surrounding environment to enhance roadway safety. As a result, it is anticipated in the future that many vehicles will be autonomous and thus there is a need to optimize the movement of these vehicles. This paper presents a new tool for optimizing the movements of autonomous vehicles through intersections: *iCACC*. The main concept of the proposed tool is to control vehicle trajectories using Cooperative Adaptive Cruise Control (CACC) systems to avoid collisions and minimize intersection delay. Simulations were executed to compare conventional signal control with *iCACC* considering two measures of effectiveness - delay and fuel consumption. Savings in delay and fuel consumption in the range of 91 and 82 percent relative to conventional signal control were demonstrated, respectively.

INTRODUCTION

Every year, about six million traffic accidents occur on US Roads [1]. While different factors contribute to vehicle crashes, driver error is considered the leading cause of more than 90 percent of all accidents, prominently distraction and/or misjudgment [1]. Consequently, the idea of an automated driving environment has been studied for decades to reduce the number of crashes and enhance mobility. Collision avoidance systems, lane-departure warning systems, automated parking systems etc. are examples of innovations focusing on vehicle automation [2], [3]. Adaptive cruise control (ACC) systems have the ability to decelerate and accelerate based on the lead-vehicle speed and system set-speed [4]. Since the initialization of research based on Vehicle Infrastructure Integration and the newer Connected Vehicles Research, communication systems promise Vehicle-to-Infrastructure (V2I) and Vehicle-to-Vehicle (V2V) information transfer are being developed using Dedicated Short-Range Communication (DSRC) and other wireless technologies [5].

These advancements lay the foundation for this research in which vehicles that assume autonomous driving (or enforced driving agents) use Cooperative Adaptive Cruise Control (CACC) to pass through an intersection devoid of signal controllers or stop/yield signs. *iCACC* stands for Intersection Management using Cooperative Adaptive Cruise Control and aims at optimizing vehicles' speed profiles to minimize delay and prevent crashes. The system is analyzed for two basic measures of effectiveness - average delay per vehicle and average fuel consumed by a vehicle to pass the intersection. Optimizing speed profiles at intersections may have an inherent advantage of reducing the fuel consumption [6]. Preliminary simulation analysis shows promising results with over 91 percent reduction in average delay and 82 percent savings in fuel consumption in the vicinity of an intersection for varying levels of volume-capacity ratios.

As far as the paper layout is concerned, a detailed description of the optimization algorithm and assumptions made are given, followed by a brief section on the preliminary simulation analysis and results drawn. This is followed by a section on findings and conclusions that can be derived as well as the future direction of this research.

OPTIMIZATION ALGORITHM

The main objective of the iCACC tool is to optimize the movements of vehicles equipped by CACC through the intersection to reduce the total delay and prevent crashes. The required inputs for the system are: 1) the physical characteristics of all vehicles, 2) entry speed and acceleration of all vehicles, 3) the weather condition (dry or wet) and 4) the intersection characteristics (number of lanes, lane width, etc.). Ideal case is assumed that vehicles pass through the intersection at speed limit. For the optimization purpose, three zones are assumed to fall in the vehicle trajectory that forms the Intersection Zone (IZ): Zone 1, Zone 2 and Intersection Box (IB), as shown in Figure 1.

In Zone 1, each vehicle accelerates to maximum speed then maintains that speed until the end of the designated length for this zone (50 meters in this paper). As a result, the end of Zone 1 is considered as the first fixed speed point in the speed profile of any vehicle in the iCACC-optimized profile where all vehicles should be running at maximum speed. This fixed speed point is called *Anchor Point*. In the absence of conflicting vehicles, a vehicle could cross Zone 2 and the intersection box (IB) at the maximum speed. However, to facilitate the optimization process in the presence of conflicting vehicles, it is assumed that all speed variation (deceleration or acceleration) occur in Zone 2 (of length 100 meters in this paper). At the end of Zone 2 all vehicles should be running at maximum speed until crossing the intersection as explained in Figure 1. This second anchor point is similar to the intersection stop line.

It is assumed that all vehicles will be crossing the intersection box at maximum speed; as a result, the only optimized variable is the arrival time at the intersection stop-bar. In other words, the iCACC system manages the speed profile of each vehicle at Zone 2 making sure that all vehicles could be running at maximum speed without stopping and certainly without conflicting with other vehicles. Figure 2 shows the 16 conflict points in a 4-legged, 3-lane intersection. Ideally, if the vehicle does not decelerate and/or stop in Zone II, it will arrive at the stop line at the shortest time possible (i.e. Optimum Time "*OT*"). However, to avoid conflicting with other intersecting vehicles, each vehicle tends to decelerate and sometimes completely stop in the traditional intersection control (signal, stop sign, etc.) and it will arrive at the stop line at a later time (Actual Time "*AT*"). By minimizing the time difference between *AT* and *OT* for all vehicles iCACC system ensures its objective -minimization of the total delay.

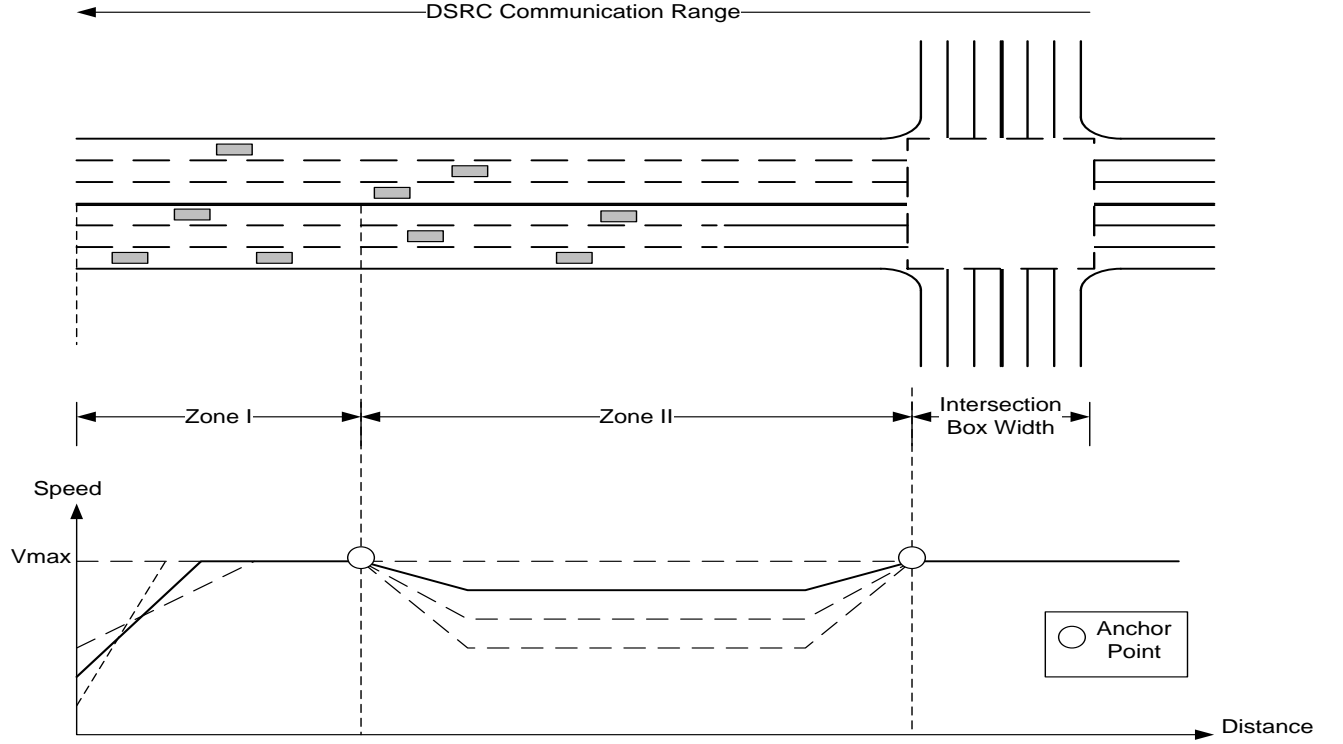

Figure 1: The different zones of the optimization process in the iCACC tool

Consequently, the decision of arrival time for each vehicle is made using an optimization module. For managing the movements of vehicles ideally, at each time step (i.e. optimization loop), an optimization module is used to optimize the time of arrival of each vehicle at the intersection stop-line. The main objective of the optimization problem is to minimize the additional time (D) to the OT , needed to avoid conflicts with crossing vehicles. This optimization problem is explained by the following equations:

$$Min : \sum_{i=1}^{\Omega^1} D_i \quad (1)$$

Subject to:

$$(OT_i + D_i) - (OT_j + D_j) \geq H_{\min}(l_{im} l_{jm}); \quad i \neq j, \forall i, j \in \Omega, \forall m \in \Psi \quad (2)$$

$$\left| (OT_i + D_i + \tau_{mn}) - (OT_k + D_k + \tau_{nm}) \right| \geq \Delta\tau(l_{im} l_{kn} c_{mn}); \quad i \neq k, \forall i, k \in \Omega^1, \forall m, n \in \Psi \quad (3)$$

$$(OT_i + D_i + \tau_{mn}) \geq \max \left[(OT_f + D_f + \tau_{mn}), (OT_p + D_p + \tau_{nm}) \right]; \quad (4)$$

$$\forall i \in \Omega^1, \forall f, p \in \Omega^0, \forall m, n \in \Psi$$

$$D_i \geq 0; \quad \forall i \in \Omega \quad (5)$$

where,

i, j, f, p = Vehicle identification number;

D_i = The time difference between the optimum time (OT) and the actual time (AT) for vehicle i and ideally it will be equal to zero if there is no speed alteration in Zone 2;

OT_i = The optimum arrival time for vehicle i at the stop line. OT_i is estimated assuming that each vehicle will accelerate to maximum speed in Zone 1 continues this speed until the stop line;

Ω^0 = the set of vehicles that entered into the system during the last time step but are still in the system at the current time step;

Ω^1 = The set of vehicles that enter the system at the current step;

Ω = The set of vehicles in the system at the current time step ($\Omega = \Omega^0 + \Omega^1$);

m, n = Lane identification number;

Ψ = The set of lanes at the intersection;

$l_{im} = 1$ if vehicle i enters into IB from lane m and 0 otherwise, with $\sum_{m \in \Psi} l_{im} = 1$;

$c_{mn} = 1$ if vehicle i from lane m has conflict point with vehicles from lane n and 0 otherwise, with $\sum_{m, n \in \Psi} c_{mn} = 1$;

τ_{mn} = Travel time from the stop-line of lane m entering into IB to the conflict point of lane n ; giving the distance to each conflict point based on the intersection geometry. It is assumed that all vehicles will be running at maximum speed in the IB, thus, τ_{mn} is fixed for all vehicles from the same lane m to same conflict point mn (to facilitate the optimization process).

$\Delta\tau$ = Time interval of a vehicle occupying the conflict point, in other words, safety time between two consecutive vehicles at the same conflict point. To simplify the model formulation and calculation, we suppose that $\Delta\tau$ values are same for all vehicles.

H_{min} = The minimum headway between vehicles in the same lane.

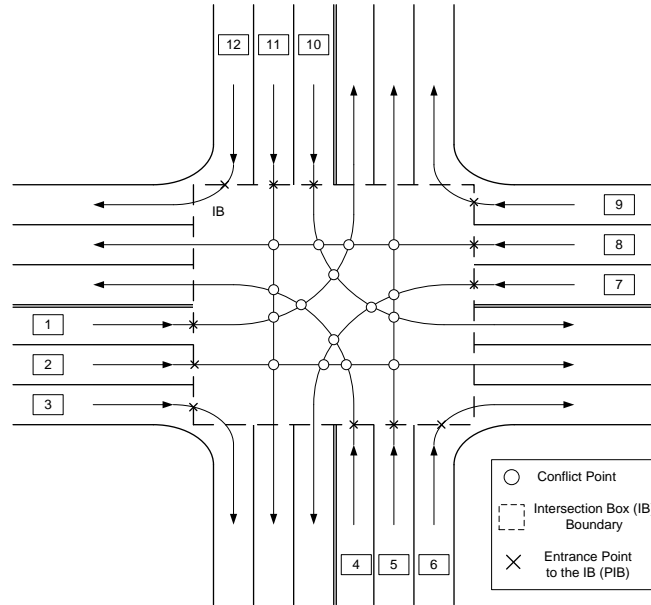

Figure 2: A typical intersection plan

The objective function (Equation 1) is to minimize the total additional time (D_i) to the optimum arrival time at the intersection box for all vehicles. In order to achieve the objective

function, four constraints have been listed. Equation 2 ensures that FCFS (first come first serve) rule is used for vehicles in the same lane. In other words, the arrival of each following vehicle should be after the leading vehicle by a determined value (minimum headway H_{min}). Equation 3 ensures that a vehicle cannot conflict with another vehicle in IB, by making sure that the arrival of two intersecting vehicles at the same conflict point is separated by minimum safe time ($\Delta\tau$). At each time step (optimization loop), vehicles in the system are divided into two groups, namely, vehicles entered in last time step but still in the IZ (Ω^0 group) and vehicles just entered in the current step (Ω^1 group). For the set of vehicles Ω^0 , their times entering to IB are optimized in last step, and each vehicle's profile has been determined/optimized. Re-optimization of times entering into IB for these vehicles can decrease calculation efficiency and increase fuel consumption caused by adjusting movements of vehicles frequently. Hence, only the set of vehicles Ω^1 are optimized at each time step. At each time step, the occupied time for each conflict point is stored as a new constraint for the following time step (optimization loop). This is the Equation 3. Last constraint is the non-negativity condition for the additional time (D_i), in other words, the additional time should be zero (no delay) or greater. At the end, the additional time needed for each vehicle to cross the intersection box safely and efficiently is converted into deceleration and acceleration acts in Zone 2.

The iCACC uses few state-of-the-art models for its optimization and comparison purposes. A vehicle dynamics model is used for predicting the speed profiles of vehicles after the optimization of the arrival times at the stop-line [7]. In order to compare fuel savings for the system, the vehicle trajectory data is used in conjunction with a fuel consumption model. Virginia Tech Comprehensive Power-based Fuel Model (VT-CPFM) is used for this purpose [8].

Vehicle Dynamics Model

This is used to model the acceleration maneuver. In doing so, the vehicle speed is computed from the resultant forces acting on the vehicle. These forces include the tractive force given by Equation 6 and various vehicle resistive forces given in Equation 7.

$$F = \min\left\{\frac{P}{3600f_p\beta\eta_d}, m_{ta}g\mu\right\} \quad (6)$$

$$R = \frac{r}{25.92}C_dC_hA_fv^2 + mg\frac{c_{r0}}{1000}(c_{r1}v + c_{r2}) + mgG \quad (7)$$

where f_p is the driver throttle input [0,1] (unitless); β is the gear reduction factor (unitless); η_d is the driveline efficiency (unitless); P is the vehicle power (kW); m_{ta} is the mass of the vehicle on the tractive axle (kg); v is the vehicle speed (km/h); g is the gravitational acceleration (9.8067 m/s²); μ is the coefficient of road adhesion or the coefficient of friction (unitless); ρ is the air density at sea level and a temperature of 15°C (1.2256 kg/m³); C_d is the vehicle drag coefficient (unitless), typically 0.30; C_h is the altitude correction factor (unitless); A_f is the vehicle frontal area (m²); c_{r0} is rolling resistance constant (unitless); c_{r1} is the rolling resistance constant (h/km); c_{r2} is the rolling resistance constant (unitless); m is the total vehicle mass (kg); and G is the roadway grade at instant t (unitless).

The vehicle acceleration is calculated as a ratio of the difference between the tractive force and resistive forces and the vehicle mass (i.e., $a = (F-R)/m$). The vehicle speed at $(t + \Delta t)$ is then computed by solving the differential equation using a first-order Euler approximation as

$$v(t + Dt) = v(t) + 3.6 \frac{F(t) - R(t)}{m} Dt \quad (8)$$

VT-CPFM Model

This paper uses the Virginia Tech Comprehensive Power-based Fuel Model (VT-CPFM-1) due to its simplicity, accuracy, and ease of calibration. The fuel consumption model utilizes instantaneous power as an input variable and can be calibrated using publicly available fuel economy data (i.e., EPA published city and highway mileage). Thus, the calibration of model parameters does not require gathering any vehicle-specific data. The fuel consumption model is formulated as Equation (9), where α_0 is the fuel consumption rate (g/s or l/s) for idling conditions and $P(t)$ is the instantaneous total power in kilowatts (kW). Estimation of the model coefficients (α_1, α_2) uses the fuel consumption rates of the standard fuel economy cycles (i.e., EPA published city and highway mileage). Specific model relations for this computation can be found in [8];

$$FC(t) = \begin{cases} a_0 + a_1P(t) + a_2P(t)^2 & " P(t) \geq 0 \\ a_0 & " P(t) < 0 \end{cases} \quad (9)$$

SIMULATION RESULTS

This proposed intersection management algorithm was tested for benefits by simulating a single 4-legged intersection with approach having three lanes (as shown in Figure 2). Each lane represents one movement, i.e. shared lanes are not considered in this tested intersection. iCACC system tool was compared to a base case where a signal controlled intersection was simulated for benefits of delay and fuel consumption. Sixteen scenarios of major and minor street volumes were tested. Each lane-width is 3.5 meter and the speed limit of 35 mph (approximately 16 m/s) for the intersection assuming zero grade. In order to calibrate the fuel consumption model and vehicle dynamics model, characteristics of a 2010 Honda Accord was used. They are provided in Table 1.

The scenarios (Table 2) were simulated for two-cases: Base case involving use of signalized controller at the intersection and the test case where intersection management is done by iCACC system. INTEGRATION micro-simulation was used for simulating the conventional intersection and optimized signal timing values were used. iCACC-based intersection was simulated using state-of-the-art traffic models for deceleration/acceleration and car-following. The entrance time of each vehicle to the Intersection Zone (IZ), their initial speed and acceleration were picked using a random number generator. Cycle times and splits optimized by Synchro 6 software was used to simulate the scenarios in INTEGRATION. A fixed turn-percentage of 0.2:0.6:0.2 was used for Left:Through:Right movements in both cases. For the test case, the intersection is simulated in MATLAB according to the algorithm described earlier, using the "moving horizon optimization" concept at each time step to fasten the optimization process. In other words, at each time step, the new vehicles entering the IZ are optimized and the vehicles already in the simulation are not optimized again. This optimization process takes shorter processing time as the preliminary optimization results for the coming vehicles are used in the following time step as initial input.

Table 4 - Physical Parameters of 2010 Honda Accord

Parameter	Value
Power of engine (P)	177 Hp
Transmission Efficiency (η)	0.92
Total Weight (W)	1453 Kg
Mass on Tractive Axle (m_{ta})	785 Kg
Roadway Adhesion (μ)	Dry = 1 & Wet= 0.8
Air Density (ρ)	1.2256 Kg/m ³
Air Drag Coefficient (C_d)	0.3
Altitude Factor (C_h)	1
Frontal Area (A)	2.32 m ²
Rolling Coefficient	Cr= 1.75 C2= 0.0328& C3= 4.575
EPA Estimates	City/Combined/Highway 21/25/31 MPG

Table 5 - Simulation results for average delay and fuel consumed for all scenarios

Scenario	Major Volume (vph/approach)	Minor Volume (vph/approach)	iCACC Case		Signal Case	
			Average Delay per vehicle (s)	Average Fuel per vehicle (l)	Average Delay per vehicle (s)	Average Fuel per vehicle (l)
1	500	250	0.6518	0.0167	11.500	0.105
2	600	300	0.6410	0.0159	11.800	0.085
3	700	350	0.8477	0.0160	13.300	0.092
4	800	400	0.9438	0.0162	13.400	0.094
5	900	450	1.2528	0.0167	13.300	0.093
6	1000	500	1.0520	0.0168	14.100	0.090
7	1100	550	0.7106	0.0182	15.000	0.092
8	1200	600	2.4354	0.0169	16.100	0.097
9	1300	650	1.2250	0.0175	16.800	0.094
8	1400	700	2.2338	0.0188	15.700	0.094
11	1500	750	2.3125	0.0172	19.000	0.094
12	1600	800	1.4795	0.0174	19.500	0.095
13	1700	850	2.2407	0.0186	18.800	0.096
14	1800	900	1.8062	0.0190	21.000	0.097
15	1900	950	2.0369	0.0170	25.100	0.098
16	2000	1000	2.8600	0.0185	26.400	0.098

Two measures of effectiveness (MOEs) tested were average delay per vehicle and average fuel consumed per vehicle to pass the intersection. Delay caused to a vehicle was computed as the deviation in time to cover the distance under consideration at speed-limit from the time it actually takes to cover the same distance. This value is averaged for all vehicles in the 16 scenarios and is shown in Figure 3. Fuel consumption estimates were made using the VT-CPFM model calibrated for the test-vehicle. Input for the model were instantaneous speed vectors for vehicles derived from MATLAB simulation and trajectories extracted from INTEGRATION. Average fuels consumed for the vehicles to pass the intersection were also computed the same way for all the 16 scenarios as shown in Figure 4. Table 2 tabulates the values of both MOEs for comparison purposes.

Figures 3 and 4 compares the benefits of iCACC intersection management over conventional signalized intersection in terms of delay and fuel consumed on a per-vehicle basis for various levels of approach volumes. Plotted values are shown in Table 2. Even though the results presented were derived using simulation output from two different sources, the results shows an insight to possible benefits of the system. The intersection and vehicles simulated in both cases were similar in all geometric and physical aspects and used same traffic models. This proves the results comparable. Figure 3 shows the average delay incurred by a vehicle in both cases. Clearly, the delay is multiple times less in case of iCACC approach with benefits averaging 96 percent. This can be attributed to the fact that iCACC tries to adjust vehicle trajectories such that they need not stop prior to the intersection thereby saving time and fuel.

The fuel savings due to inertia and a higher average speed is shown in Figure 4, where fuel benefits are compared for the two cases. An average savings of 77 percent in fuel is shown for the iCACC case over conventional approaches.

It should be stated that the scenarios simulated represents uncongested conditions. Consequently, dealing with traffic demand at an intersection in a vehicle-by-vehicle basis, as in iCACC case, reduces the delay extensively when compared to the conventional signal controlled case. In case of high-volume intersections, the optimization algorithm in iCACC will start compromising constraints of no-stopping and starts vehicles to queue prior to intersection and cross it approach-by-approach. In other words, by increasing the volume of vehicles at intersections, the iCACC system will turn into a regular signal control due to the accumulation of vehicles in the queue. It is anticipated that the proposed framework will be used in the future of intersections control for automated vehicles since it not only seeks crash avoidance but also reduces the total delay.

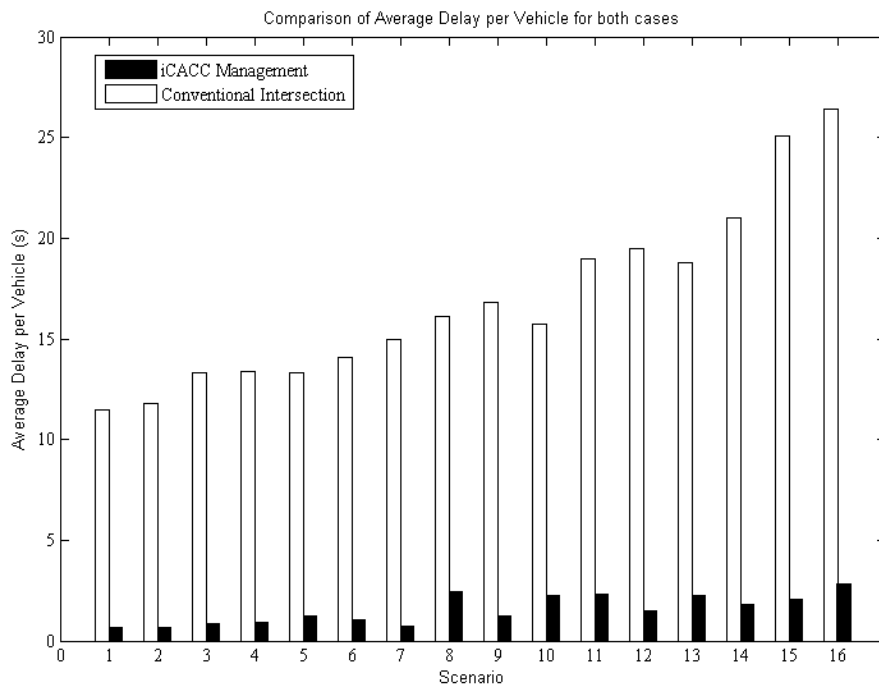

Figure 3: Delay per vehicle (s) comparison between conventional control and the proposed iCACC control

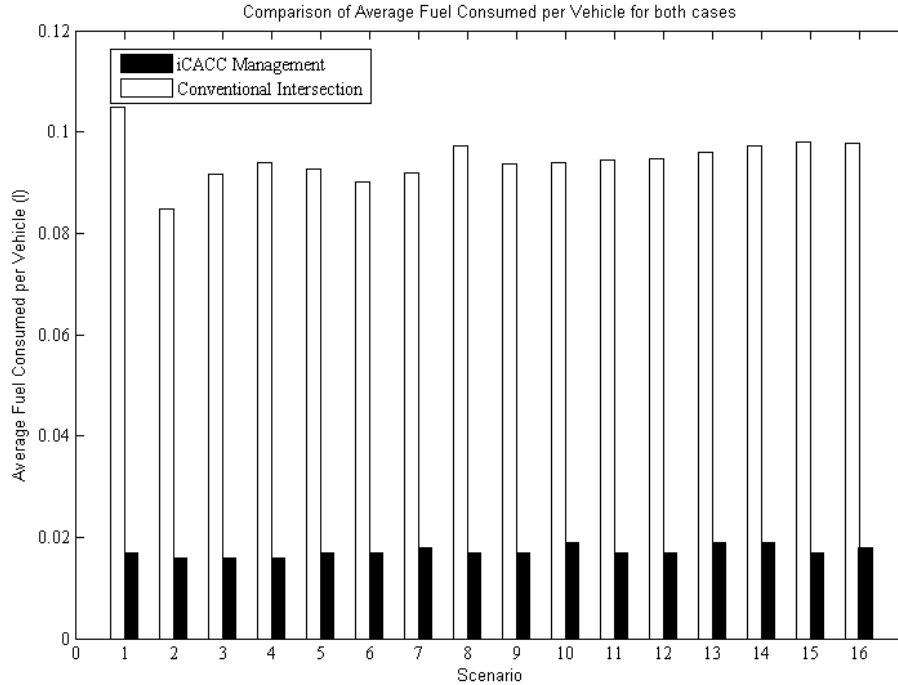

Figure 4: Fuel consumed per vehicle (l) comparison between conventional control and the proposed iCACC control

CONCLUSIONS

Autonomous vehicles are considered a major part of the future intelligent transportation systems. Semi-automated systems in which the speeds are governed by sensors using Adaptive Cruise Control systems are already available in market. Along with the goal of removing human's distracted driving to make roadways safer and increasing use of technology in cars, it is necessary to have a replacement for the conventional signal controlled intersection. This research attempts to present an innovative approach for optimizing the movements of vehicles equipped by Cooperative Adaptive Cruise Control systems at "smart" intersections. A few attempts have been made in the literature for the use of CACC technology at intersections. However, the past research efforts did not explicitly optimize the total delay at the intersection as they focused more on optimizing acceleration/deceleration levels for crash avoidance and/or emissions.

The research specified in this paper relies on advanced computing at "smart" intersections where the controller can "talk" to cars and back for the CACC systems to function. The intersection controller would advice the vehicle, the best action needed to reduce the total delay and prevent crashes at each time step. The iCACC system tool presented in this paper has the capability to capture the physical characteristics of concerning the acceleration/deceleration, the different weather conditions (roadway surface) and the different movements at intersections. In addition, the algorithm has the ability to apply the moving horizon concept in optimizing the movements of vehicles, in other words, it could optimize a time step ahead to speed up the process and overcome any uncertainty in the simulation.

This paper presents the preliminary results of this research where one vehicle type was simulated with a single intersection. All vehicles in the simulation were assumed to have CACC system to send/receive information and follow speed advices as directed. In future, simulations

with more types of vehicles and more number of adjacent intersections need to be done. The results from this research also warrant studies with regard to incorporating non-CACC vehicles into the system and studies pertaining to tackling unexpected system changes, pedestrian movements etc. It is anticipated that this research will contribute in the future of intelligent transportation system (ITS), connected vehicle technology systems, and driverless vehicles applications.

ACKNOWLEDGMENTS

The authors acknowledge the financial support provided by the Mid-Atlantic Universities Transportation Center (MAUTC) in conducting this research effort. In addition, the authors acknowledge the valuable input of Dr. Qingcheng Zeng at Virginia Tech Transportation Institute.

REFERENCES

- [1] NHTSA, "Traffic Safety Facts 2006 Data," Washington D.C., 2008.
- [2] J. C. S. Jr and J. B. Flannery, "Anti-Collision Vehicular Radar System," U.S. Patent 43085361981.
- [3] S. Kim and S. Oh, "A driver adaptive lane departure warning system based on image processing and a fuzzy evolutionary technique," *Intelligent Vehicles Symposium, 2003.*, pp. 361-365, 2003.
- [4] P. I. Labuhn and W. J. Chundrlik, "Adaptive Cruise Control," U.S. Patent 54544421995.
- [5] ITS JPO, "Connected Vehicles Technology," *Connected Vehicles Research*, 2012. [Online]. Available: http://www.its.dot.gov/connected_vehicle/connected_vehicle_tech.htm. [Accessed: 2011].
- [6] H. Rakha and R. K. Kamalanathsharma, "Eco-driving at Signalized Intersections using V2I Communication," in *14th International IEEE Annual Conference on Intelligent Transportation Systems*, 2011.
- [7] H. Rakha, M. Snare, and F. Dion, "Vehicle dynamics model for estimating maximum light-duty vehicle acceleration levels," *Transportation Research Record: Journal of the Transportation Research Board*, vol. 1883, no. 1, pp. 40–49, Jan. 2004.
- [8] H. A. Rakha, K. Ahn, K. Moran, B. Saerens, and E. V. D. Bulck, "Virginia Tech Comprehensive Power-Based Fuel Consumption Model: Model development and testing," *Transportation Research Part D: Transport and Environment*, vol. 16, no. 7, pp. 492-503, Oct. 2011.