

Planter/Drill Considerations for Conservation Tillage Systems

Robert "Bobby" Grisso, Extension Engineer, Biological Systems Engineering, Virginia Tech

David Holshouser, Extension Soybean Specialist, Tidewater Agricultural Research and Extension Center, Virginia Tech

Robert Pitman, Superintendent, Eastern Virginia Agricultural Research and Extension Center, Virginia Tech

No-till planters and drills must be able to cut and handle residue, penetrate the soil to the proper seeding depth, and establish good seed-to-soil contact. Many different soil conditions can be present in the Mid-Atlantic region at planting time. Moist soils covered with residue, which may also be wet, can dominate during the late fall and early spring and occasionally, in the summer. Although this condition provides an ideal environment for seed germination, it can make it difficult to cut through the residue. In contrast, hard and dry conditions may also prevail. Although cutting residue is easier during dry conditions, it is more difficult to penetrate the hard, dry soils. Proper timing, equipment selection and adjustments, and crop management can overcome these difficult issues.

Condition of the Field and Residue

Management of the previous crop residue and weed control are key factors for successful no-till equipment operation. If residue and weed issues are not considered, then the ability of the planter or drill to perform its functions is greatly limited. The residue has to be uniformly spread behind the combine if the opening devices are going to cut through the material. It is very difficult for the planter/drill to cut the residue if the combine has left a narrow swath of thick residue and chaff. Equip the combine with a straw chopper and chaff spreader to distribute residue and chaff over the entire cut area.

For example, a 30-foot platform header cutting high-yielding small grain will dump the material into a 5- to 6-foot swath. This swath contains 5 to 6 times more material than the other cut area. This mat of material is an ideal place for disease and pest problems to accumulate and increases problems relating to cutting residue and penetrating the soil. This mat can create a lot of variability that makes it difficult to adjust the planter/

drill for proper operation and this can limit successful emergence and early crop growth. Experience has shown that the residue is best handled by the planter/drill when the residue remains attached to the soil and standing. When the standing residue is shredded and chopped in a separate operation, it has a tendency to mat and remain moist longer than residue left standing. The loose residue may not flow through the planter/drill as well and has the potential to plug opening devices.

The other key is weed control. If standing weeds exist, the planter/drill must cut and move this extra living plant material through the system. In addition, mature weeds have viable seeds that will germinate ahead of the crop. Weeds that have a head start on the crop will compete for light, water, and nutrients more than weeds emerging with the planted crop. Therefore, weeds need to be controlled before crop emergence or soon afterwards to prevent yield loss.

Row-cleaning Devices

Row-cleaning attachments are not necessary in most no-till applications, especially if coulters or double-disk furrow openers cut the residue. However, row cleaners can help warm the cool early spring soils by moving the residue away from the row and exposing the clean row to direct sunlight and air. When planting in heavy surface residue in early spring, using row cleaners to move only residue away from the row can aid in soil warm-up. This can be especially helpful on poorly drained soils.

Double-disk furrowers, spoked 'spider-wheel' row cleaners (Figure 1), row-cleaning brushes, sweeps, or horizontally mounted disks in front of the planting unit move residue away from the row. Disk row cleaners are also useful in moving clods.

www.ext.vt.edu

Produced by Communications and Marketing, College of Agriculture and Life Sciences,
Virginia Polytechnic Institute and State University, 2009

Virginia Cooperative Extension programs and employment are open to all, regardless of race, color, national origin, sex, religion, age, disability, political beliefs, sexual orientation, or marital or family status. An equal opportunity/affirmative action employer. Issued in furtherance of Cooperative Extension work, Virginia Polytechnic Institute and State University, Virginia State University, and the U.S. Department of Agriculture cooperating. Mark A. McCann, Director, Virginia Cooperative Extension, Virginia Tech, Blacksburg; Alma C. Hobbs, Administrator, 1890 Extension Program, Virginia State, Petersburg.

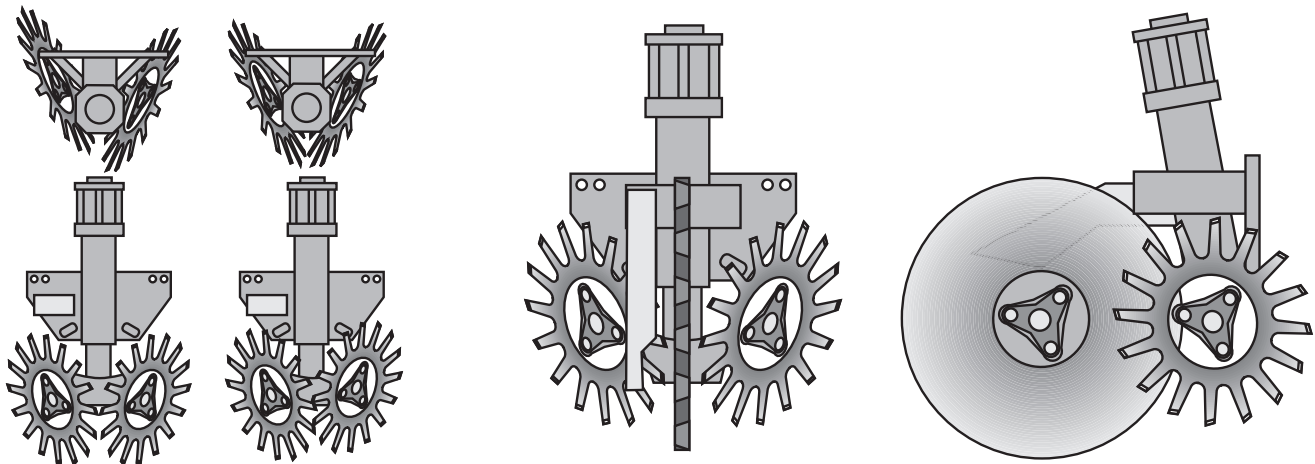

Figure 1. Row-cleaning devices on a planter unit will move residue from the seed zone.

Row cleaners should not be used on highly erodible soils or in areas where moisture conservation is needed. Residue over the row reduces raindrop impact, slows runoff, and provides a mulch to reduce drying of the seed zone. On poorly drained soils, spoked 'spider-wheel' row cleaners could be used to move residue off the row to aid in soil drying. Unlike disk row cleaners, the spoked wheels should be set to move only residue and not contact the soil. Soil can fill the areas between the spokes and render the wheels ineffective.

When furrowing devices are used to move residue, clods, or soil from the row, any previously applied herbicide will be moved out of the row area, leaving an untreated seedbed. An alternative herbicide program or a band application of herbicide behind the planting unit may be needed.

Coulters and Seed Furrow Openers

The primary differences between conventional planter/drill systems and those designed for conservation tillage systems are the down pressure and weight. Since the no-till openers and soil engaging devices deliver more down pressure to penetrate much firmer soils and cut the residue, the conservation planter/drill systems are built heavier and have the ability to carry much more weight than conventional tillage systems.

Although not necessary, coulters can be added in front of the planter openers to ensure residue cutting. For adequate coulters penetration, weight may have to be added to the carrier. Some planter/drills use a weight-transfer linkage to transfer some of the tractor weight to the coulters to ensure penetration. Because coulters are

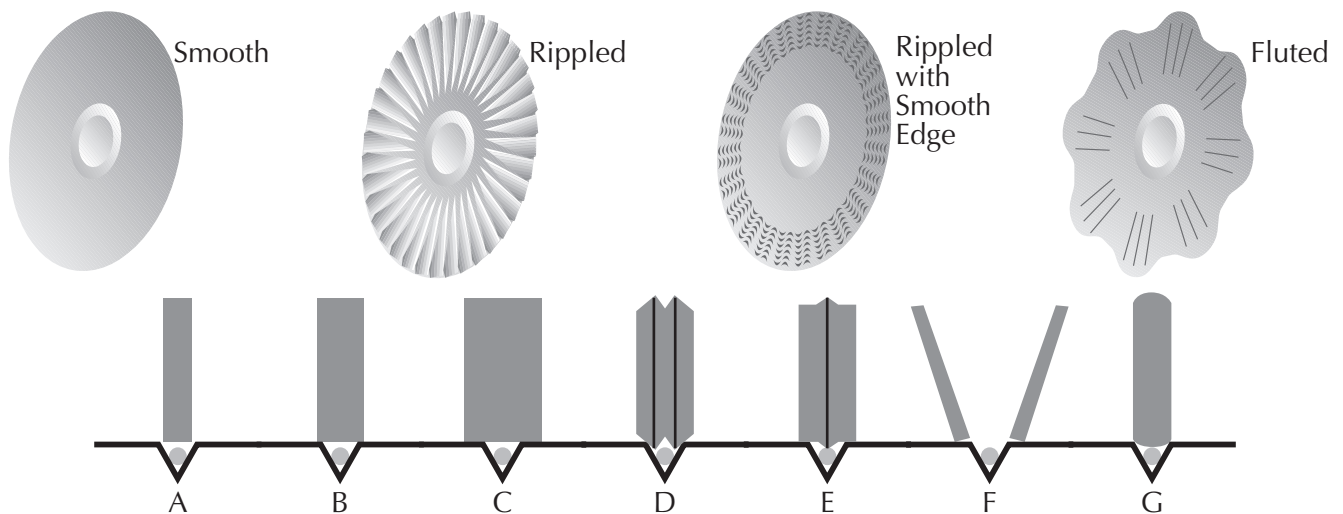

Figure 2. Top row shows common coulters styles and the bottom shows various types of press wheels. Press wheels (bottom row) are defined as: A) 1-inch wide wheel that presses directly on the seed in the bottom of the seed furrow, B) 2-inch wide wheel that presses on the seed and gauges planting depth by riding on the sides of the seed furrow, C) wide press wheel that gauges planting depth but does not press directly on the seed, D) wide press wheel with two ribs that applies pressure on the side of the seed furrow to press soil on the seed while gauging the depth, E) wide press wheel with one center rib that applies pressure on the seed furrow to press while gauging the depth, F) pair of angled press wheels that close the seed furrow and establish seed-to-soil contact, G) narrow steel press wheel that applies pressure directly on the seed but does not flex to 'shed' soil in sticky conditions.

usually mounted several feet in front of the seed opening/placement device (in the case of coulters caddies even further), many use wide-fluted coulters (Figure 2). A pivoting hitch or a steering mechanism will keep the seed openers tracking in the coulters slots.

Wide-fluted coulters (2 to 3 inches wide, see Figure 2) perform the most tillage and open a wide slot in the residue. This wide slot allows the soil to warm-up faster (more drying, may be a disadvantage in some situations) and may prepare an area for improved soil-to-seed contact. However, because of the increased cutting surface, fluted coulters require more weight for penetration, disturb more soil surface, and bury more residues. In wet conditions on medium- and fine-textured soils, fluted coulters may loosen too much soil and cause the loose, wet soil to stick to the seed openers and press wheels. This will result in clogging, inconsistent depth control, and poor soil-to-seed contact.

Narrow-fluted coulters (0.5 to 1.0 inch wide, see Figure 2) or narrow bubble coulters, ripple coulters, and turbo-rippled coulters do not require as much weight for penetration and do not throw as much soil out of the seed furrow as the wide-fluted coulters. Ripple coulters with a smooth edge or smooth coulters are preferred for residue cutting. They can be sharpened to maintain the cutting surface. Operate all coulters close to seeding depth (Figure 3) to avoid excessive soil throwing at

high operating speeds and to limit the formation of air pockets below the seed furrow. Use the largest diameter coulters available (that fit the planter, coulters-caddy, etc.) because they have the best angle for cutting residue.

Most no-till planters/drills are equipped with independent seeding units that should allow at least 6 inches of vertical movement. This will allow the unit to operate over rough transit, over non-uniform surfaces, and adjust for root stubs and other obstacles. These units are sometimes staggered to provide more side-to-side space for residue flow, which helps with unit function. These units should be equipped with heavy down-pressure springs and sufficient weight to ensure penetration of both the coulters and seed furrow openers into untilled soil. Usually these springs are adjustable and multiple springs can be added if insufficient pressure is achieved.

Some no-till planters/drills are not equipped with coulters (Figures 3-A and 3-D). These planters/drills use the seed furrow openers to cut and place the seed. Several planter/drill systems have a staggered double-disk seed furrow opener without a coulters (Figures 3-C and 3-E). The leading disk (usually 0.5 to 1.0 inch in front) cuts the residue and the second aids in opening the seed furrow. Some manufacturers use a single, large disk set at a slight angle. These units require less weight for penetration and provide minimal soil disturbance.

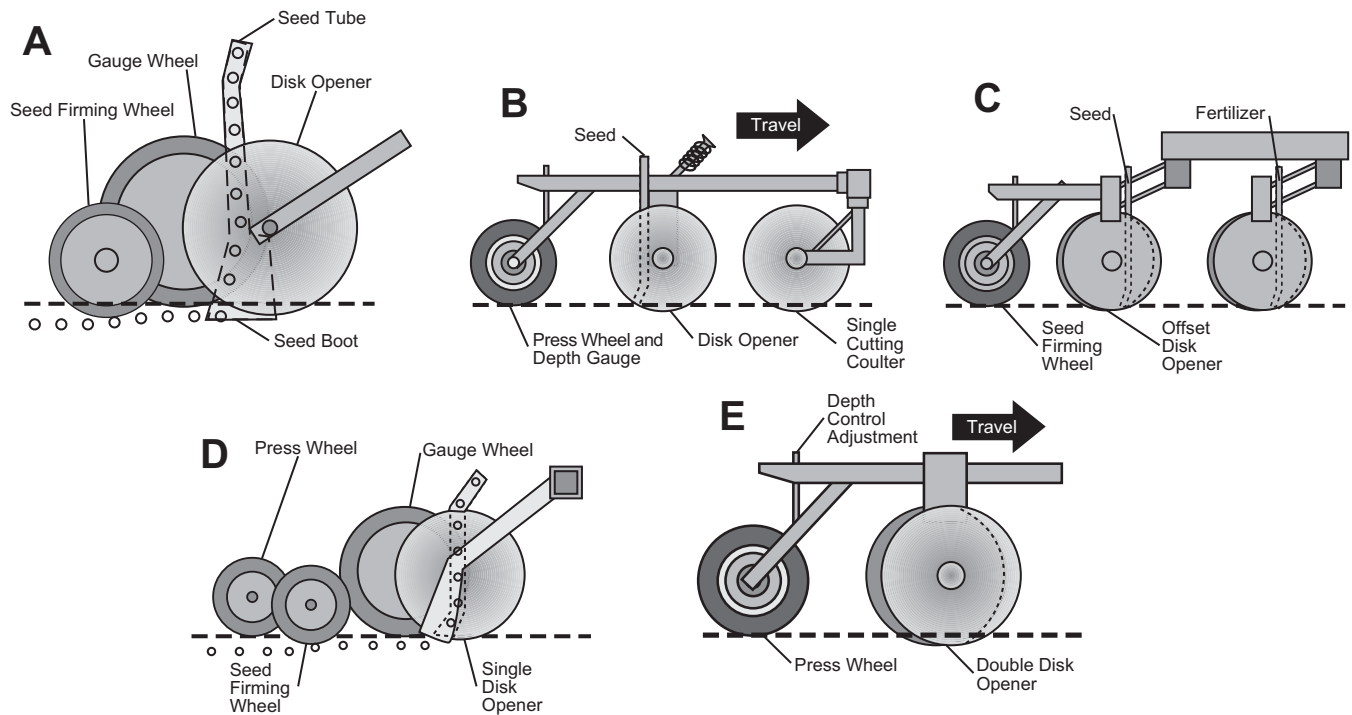

Figure 3. Diagram of typical seeding mechanisms: A) single-disk opener, B) single-disk opener with add-on coulters unit, C) offset double-disk openers with fertilizer opener mounted midway between seed openers, D) gauge wheel mounted beside the seed-opener disk to maintain depth control, E) press wheel mounted on the furrow-opener frame member to maintain depth control.

Adjusting Disc Openers

Operators of no-till planters/drills with offset double-disk openers need to watch the leading edge of the double-disks for significant wear. Single-disk openers are also subject to similar wear. Essentially, the leading edge of the disk takes the abrasion and wear of cutting straw or stalks and penetration into the soil. The leading and trailing disk typically are two different parts and cannot be interchanged. As the double-disk openers wear, check the gap between them. If a gap opens between the double-disks, they will push residue into the furrow and have less ability to cut the residue. For offset double-disk openers, a business card-width gap should be maintained to prevent the trailing disk from cutting into the leading disk blade

Maintain approximately 1.0 to 1.5 inch of contact between the two disks (see Figure 4). Adjustment washers are found in the double-disk opener assembly, which allow some adjustment to compensate for wear. Machine bushings located on the spindle between shank and disc blade can be added or removed as required to maintain approximately 1.0 to 1.5 inch of contact between double-disks. As the blade diameter decreases because of wear, it will be necessary to remove the machine bushings to maintain approximately 1.0 to 1.5 inch of contact. If approximately 1.0 to 1.5 inch of blade-to-blade contact cannot be maintained after removing machine bushings, if blade diameter is worn below the manufacturer's recommendations, or if the blade edge is bent, chipped, or jagged, the blade should be replaced.

Check end play of the disk opener by shaking it from side-to-side. With the single-row ball bearings, some end play will be normal. The disc is stabilized by the contact between the double-disk openers. However, if end play is excessive and the bearing sounds dry when

turned, replace bearing/hub assembly or complete disc assembly. Also, check to see that the bearing hubcap is in place. Replace the hubcap if it is lost or damaged.

More on Weight and Down Pressure

Individual openers should have sufficient down-pressure and independent depth control to allow movement up and down to ensure that all rows are operating at the same depth. Depending on coulter width, opener design, soil texture, and field conditions, up to 500 pounds per row may be necessary for adequate penetration. Down-pressure springs on independent row units must transfer enough weight from the drill frame so that all meter wheels, seed openers, and all depth control devices and seed pressure wheels are firmly contacting the soil.

Having enough weight becomes more of a problem with drills simply because of the number of rows per unit width. A drill with 7.5-inch row spacing has four times the number of row units for a given width of operation as a planter with 30-inch spacing. Thus, to maintain adequate down-pressure per unit, the total weight of a drill with 7.5-inch row spacing needs to be four times the weight of a planter with 30-inch row spacing. For instance, a six-row planter on 30-inch row spacing may require more than 3,000 pounds of weight (six rows times 500 pounds per row) just for cutting the residue and penetrating the soil. Whereas, a drill of the same width on 7.5-inch row spacing has 24 openers and may require more than 12,000 pounds for proper penetration. In some cases with insufficient drill weight, the springs may physically lift the meter drive-wheel off the ground. Some manufacturers use a spring-loaded drive mechanism to keep the drive firmly in contact with the soil, but this still requires adequate total drill weight for proper operation.

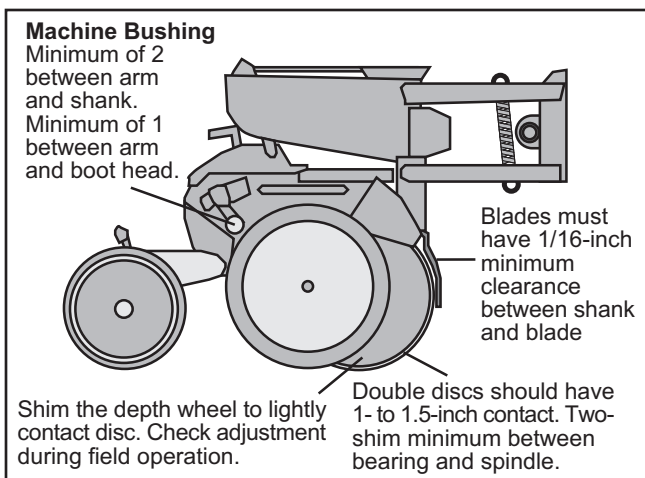

Figure 4. Adjustments to double-disc openers on a planter unit.

Seed Meter Devices

When comparing planter/drill systems, be sure to evaluate the different metering devices and their influence on germination and plant-stand consistency. For example, the conventional fluted meters for drills often result in poorly spaced stands with many gaps. To compensate for this stand variability, many operators will over-seed small grains by 10 percent to 20 percent. The interest in the drills with singulation devices similar to row-crop meter devices (see Figure 5) is due to the possibility of improving stands, reducing seed cost (from not over-seeding), and reducing variability seen in conventional fluted-meter devices.



Figure 5. Seed metering for seed singulation on a grain drill. Meter device is shown with gear and chain drive (see Figure 6 for location).



Figure 6. Precision seeding system with seed meters close to the ground. ("A" marks the metering device).



Figure 7. Planter equipped with extra planter boxes to plant 15-inch rows.

Research shows that conventional fluted-meter devices evaluated for variable-rate seeding are not very accurate. Fluted meters have a cup on a rotating shaft and an opening gate. The tests show that changing the shaft speed, forward speed, or gate opening greatly hindered the accuracy of population and spacing of the seed. As the seeds increased in size, the variability was even greater. The conventional fluted-drill meter devices do not need singulation accuracy because small grains can usually compensate for the inconsistency. This may not be the case for soybeans and definitely not for corn. Some accuracy and spacing uniformity can be gained with very specific travel speeds and fixed population. Accuracy degrades quickly if travel speed is not consistent. Another problem that contributes to the lack of seed-spacing uniformity is the distance from the meter to the seed furrow. Seed bounce and travel in the seed delivery tube greatly influence the spacing uniformity.

With these inherent problems of conventional fluted-meter devices, manufacturers have designed spiral cup, belted meters, and meter devices that singulate out the individual seeds (potential to plant corn). Designers also moved the meter device closer to the ground (Figure 6) to reduce the travel distance to the seed furrow. The new meter device on the Precision Seeding System™ by Great Plains Manufacturing, Salina, Kansas, has singulation features and a narrow profile that allows 7.5-inch drill spacing.

Manufacturers have also adapted row-crop planters (see Figure 7) for narrow row (15-inch) spacing to give producers the seed singulation and spacing accuracy as well as a machine that could be used for both drilled and row-crops. Several manufacturers have configured row-crop planters so that they are easy to convert from 15- to 30-inch row spacing.

Since the meter devices of some systems are close to the ground, they are difficult to calibrate and check the seed population. Most manufacturers recommend a static test by rotating the meter drive wheel. While this can be a reflection of the accuracy and uniformity of the individual units, it may not give accurate measurements for field conditions. Be prepared to spend some time in the field observing the seed spacing and calculating seeding population by digging into several seed furrows.

Several seed companies, plus a number of equipment dealers, offer meter testing with the use of planter test stands. One of the more popular test stands being used is called the Meter Max™ manufactured by Precision Planting™, Tremont, Illinois. This type of meter test

stand not only measures the accuracy of seeding rate, but also produces the uniformity statistics of the seed drop by virtue of the seed dropping onto a horizontal seed belt.

Corn Plant Space Variability

Properly adjusted corn planters can singulate and uniformly space seed. Even stands reduce plant-to-plant competition and take maximum advantage of sunlight to produce increased yields. Doubles or triples and large gaps can result in lost yield potential. Research indicates that a 1-inch increase in standard deviation of corn plant spacing results in yield losses up to 2.5 bushels per acre. A ten-year study of stand observations from over 350 corn fields found that 84 percent of the fields had a standard deviation in plant-to-plant spacing of more than 4 inches, which translated into potential yield losses of 5 to 12.5 bushels per acre.

Researchers concluded that skips contribute to the standard deviation or plant-to-plant variability slightly more than doubles. They further concluded that skips reduce yield in fields where the intended population is at or below the optimum, while doubles increase yield when populations are less than optimum.

Three key points from this research are:

- An adequate plant population should be selected,
- Depending on the season, plant-to-plant spacing variability may not always result in yield loss, and
- Skips limit yield more than doubles.

Seed Tube Guard

The seed-tube guard protects the seed tube and acts as the inner scraper for the double-disk opener. Remove the seed tube and check for wear. Excessive wear on the seed tube indicates a worn seed-tube guard. No-till planting or planting in hard ground conditions will greatly increase seed-tube guard wear and necessitate frequent inspection. Additional side pressure of the double-disk opener against the guard also causes increased wear.

Initial width of the guard at the lower end is approximately 0.88 (7/8) inch. When the seed tube guard is worn to approximately 0.5 inch, replace it. If the guard is worn excessively, it may also allow dirt buildup on

the inside of the disc blade and cause seed to be flipped out of the seed trench by the disc openers.

Press Wheels and Depth Control

There are two methods for seed-depth control on most no-till planter/drill systems: 1) setting the depth from a gauge wheel adjacent to the seed furrow device (Figures 3-A and 3-D), or 2) adjusting press wheel pressure behind the seed furrow openers (Figures 3-B, 3-C and 3-E). In either case, keep adequate pressure on the gauge or press wheel to force the openers into the soil to the proper depth. A harrow behind a drill ensures seed coverage and redistributes residue for effective conservation measures. Regardless of the depth control, wide-flat press wheels (Figure 2-C) are unacceptable for no-till since they will ride on the firm soil adjacent to the seed furrow and will not firm the seed into soil. A wide press wheel equipped with a rib that runs on the sides of the seed furrow or a rib that runs directly over the furrow to press the seed is adequate for good seed-to-soil contact (see Figure 2-E).

Another option is to use a pair of angled press wheels (Figure 2-F) behind the opener to close the seed furrow at the same time. When using angled press wheels, ensure that pressure is not placed on the seed furrow to the point that a ribbon of soil moves the seed up. If available, adjust the angle such that the angle of the press wheels meets at the seed depth.

The disadvantage of any system using the press wheel for depth control is its distance from the seed opener. As the distance increases there is a greater possibility that irregular terrain will influence both depth control and the press wheel's ability to provide good seed-to-soil contact.

Sufficient weight must remain on the press wheels to ensure firming of the seed into the soil. Wet soil is easily compacted and care must be taken not to over pack the soil, making it difficult for seedling roots to penetrate the soil. In dry soil conditions, extra closing force may be needed. The key is to evaluate seed-to-soil contact, not the top of the seed-vee. As long as the contact is there, something as simple as a harrow that acts to close the top of the vee and pull light residue cover back over the vee may be all that is needed. This is a common practice on drills that use a narrow press wheel.

Setting Planters and Drills for the Season

When the weather and time are right for planting, producers should be in the field planting, not getting equipment ready and making last minute repairs. All repairs should be made at the end of planting season when problems are fresh in producer's minds.

In the shop. Read the owner's manual for suggested maintenance and lubricate as directed. Check the operation of the seed metering devices and replace worn parts. Adjust the seed metering devices using this year's seed to match seed size and shape. Check, adjust, and lubricate chains, sprockets, bearings, and fittings. Replace worn ones. Adjust or replace the seed-furrow opener disks and other ground engaging components. Properly inflate all tires, including those on the tractor.

In the field before planting season. Set the toolbar and the hitch point at the proper height to match soil conditions. Level the planter from front-to-rear, slightly tail down to help with seed-to-soil contact. Blind plant (or use old seed) for a short distance to check operation: check residue cutting and handling, check penetration to desired seeding depth, evaluate seed-to-soil contact, and evaluate closing the seed-vee. Adjust down-pressure springs to improve residue cutting and seedbed penetration. Add weight as needed for the down-pressure springs to work against and to keep the drive wheels in firm contact with the ground to avoid slippage.

General Operation

Adjustments maybe needed as soil and residue conditions change. Continuously monitor planter performance and make adjustments as conditions dictate. Since the planter/drill system must handle and cut the residue, allow the residue to dry and become crisp before planting. These conditions aid in the cutting and handling of the residue. The weight of the drill and pressure from the down-pressure springs are essential for cutting residue, penetrating the soil, and preventing seed openers from bouncing over residue. Most manufacturers suggest operating speeds of 6 to 10 mph. While this hinders accurate metering from fluted-meter devices, a higher operating speed assists in residue flow, especially for planter/drills equipped with a coulter caddie and/or a harrow.

In the field during planting season, especially when changing fields. Check residue cutting and handling. Leave more residue over the row as the weather warms up to reduce seedbed drying. Check planting depth and seed-to-soil contact. Back off on pressure in wet soils that are easily compacted. Slow down to improve seed placement uniformity. Check seed spacing for proper population. Adjust harrows on drills to redistribute residue and help close the seed-vee.

Check seed depth. Drill depth control surveys indicated a strong tendency to plant much deeper than intended. Only 20 percent of the producers were at or near the intended depth, and 68 percent of the fields were planted too deep. Excessive depth delayed germination and reduced stands. These same surveys found that producers are much more accurate with population rate than with planting depth.

Check for seeds on the ground. The closure and seed-to-soil contact device should be adjusted if seeds are found on the soil surface.

Varying soil and residue conditions across the field. If depth control is insufficient due to soft soil conditions (sandy soils) or if residue amounts are changing, check to see if the manufacturer offers some additional down-pressure spring kits that activate more spring pressure as conditions dictate and less when the down pressure is not needed.

Check for hairpinning. When operating a planter/drill system in heavy residue, residue may be pushed in the seed furrow (hairpinning), reducing seed-to-soil contact and slowing or reducing germination. Make sure the cutting angle on the coulter is correct (coulter depth should not exceed one-third the coulter radius) and the cutting edge is sharp. Depending on the conditions, a smooth coulter may provide the needed cutting of residue better than a fluted coulter. The hairpin effect is minimized when seeding units operate on a firm soil, and when residue is dry and crisp. Simply waiting until a little later in the day, when residue is drier, may greatly improve the operation of the planter/drill system.

Erratic Operation. Any time the operation of the planter causes the metering unit to jerk, variable seed placement will occur. Adjust all elements of planter operation for smooth performance. Observe and adjust planting speed to match ground conditions.

Servicing Seeding Equipment

Check out the related references below for links to service support Web pages. Here are some general guidelines and tips for planter maintenance and adjustments.

- Clean the planter/drill inside and out. This should be done before the unit is sheltered. Check for old seed left in the hoppers, mouse nests, spiders, insects, build-up from seed coatings and anything else that may interfere with the operation of the seed meter or seed drop tubes.
- Check and replace all worn out parts.
- Ensure that coulters and openers are aligned accurately.
- Replace worn seals and check trueness of fit.
- Adjust or replace worn openers.
- For finger-pickup type meters, check finger-pickup back plates for rust buildup, seed treatment residues, and worn down ‘dimples.’ Check and adjust finger tension.
- Check condition of seed belt. Also, check condition of belt sprocket teeth.
- Replace worn chains. Lubricate or replace chain links.
- Inflate tires to the correct inflation pressure.
- Clean seed tubes and monitor sensors to ensure accurate monitoring of seed flow.
- Replace seed tubes if excessively worn at bottom.

CALIBRATE!

- For all metering units:
 - Calculate and record the seed weight for each seed lot you intend to plant.
 - For air/vacuum metering, identify and record the correct pressure (air or vacuum) for the calculated seed weight and identify the correct seed disc (or drum) for the calculated seed weight.
- Double-check the operations manual and identify the correct transmission setting for the desired seeding rate.
- Calibrate actual seed drop against:
 - Planter transmission settings
 - Planter monitor readouts
- Calibrate at normal planting speeds and seeding rates.
 - Calibrate in as close to field conditions as possible, not in the farm lane.
- Calibrate pesticide and fertilizer planter attachments at the same time because application rates can easily change from year to year.
- Check that the planter toolbar is parallel to the ground when planter is in use because this affects disc opener depth, press wheel efficiency, and seed-to-soil contact.

Summary

Successful planting/drilling with no-till equipment depends on specially designed systems that can uniformly place seed through heavy residue and into firm, moist soil. No-till equipment is available to achieve these results for good yields.

References

Conservation Tillage Systems and Management. 2000. MWPS-45, Second Edition, MidWest Plan Service, Iowa State University, Ames, IA 50011, pg 270.

Dickey, E.C., and Jasa, P. 1989. Row Crop Planters: Equipment Adjustments and Performance in Conservation Tillage. NebGuide G83-684, University of Nebraska Cooperative Extension, Lincoln, NE 68583.

Grisso, R.D., Holshouser, D., and Pitman, R. 2002. *Equipment Considerations for No-till Soybean Seeding*, Virginia Cooperative Extension publication 442-456. <http://pubs.ext.vt.edu/442-456/442-456.html>

Related Service Web Sites

Case-IH. Parts & Service, <http://www.caseih.com/parts/parts.aspx?navid=123&RL=ENNA> (URL verified 6/6/06).

Deere & Co. John Deere Services and Support, http://www.deere.com/en_US/ag/servicesupport/index.html (URL verified 6/6/06).

Kinze Manufacturing. Kinze Product Service, <http://www.kinzemfg.com/service.html> (URL verified 6/6/06).

Kinze Manufacturing. Kinze Finger Pickup Corn Meters: Repair, Maintenance, and Adjustments, <http://www.kinzemfg.com/pdf/servicepdfs/cmeterfact-020101.pdf> (URL verified 6/6/06).

Kinze Manufacturing. Kinze Row Unit and 3000 Series Planter Maintenance Reference Guide, <http://www.kinzemfg.com/pdf/servicepdfs/rum1000.pdf> (URL verified 6/6/06).

Great Plains Manufacturing, <http://www.greatplainsmfg.com/>

Precision Planting, <http://precisionplanting.com/>

S.I. Distributing, Inc., <http://www.sidist.com/index.html>

Acknowledgements

The authors express their appreciation for the review and comments made by Joel Faircloth, assistant professor and Extension cotton/peanut specialist, Crop and Soil Environmental Sciences, Tidewater AREC; Chris Teutsch, associate professor and Extension forage specialist, Crop and Soil Environmental Sciences, Southern Piedmont AREC; Matthew Lewis, Extension agent, Northumberland County; Scott Reiter, Extension agent, Campbell County; Brad Jarvis, Extension agent, Madison County; Wade Thomason, assistant professor and Extension grains specialist, Crop and Soil Environmental Sciences; all from Virginia Tech; Chris Lawrence, agronomist, USDA-NRCS, Richmond, Virginia, and Keith Burgess, conservation specialist, Monacan Soil and Water Conservation District.

Disclaimer: Commercial products are named in this publication for informational purposes only. Virginia Cooperative Extension does not endorse these products and does not intend discrimination against other products which also may be suitable.