

The Virginia Gardener Year Round Guide To Nutrient Management

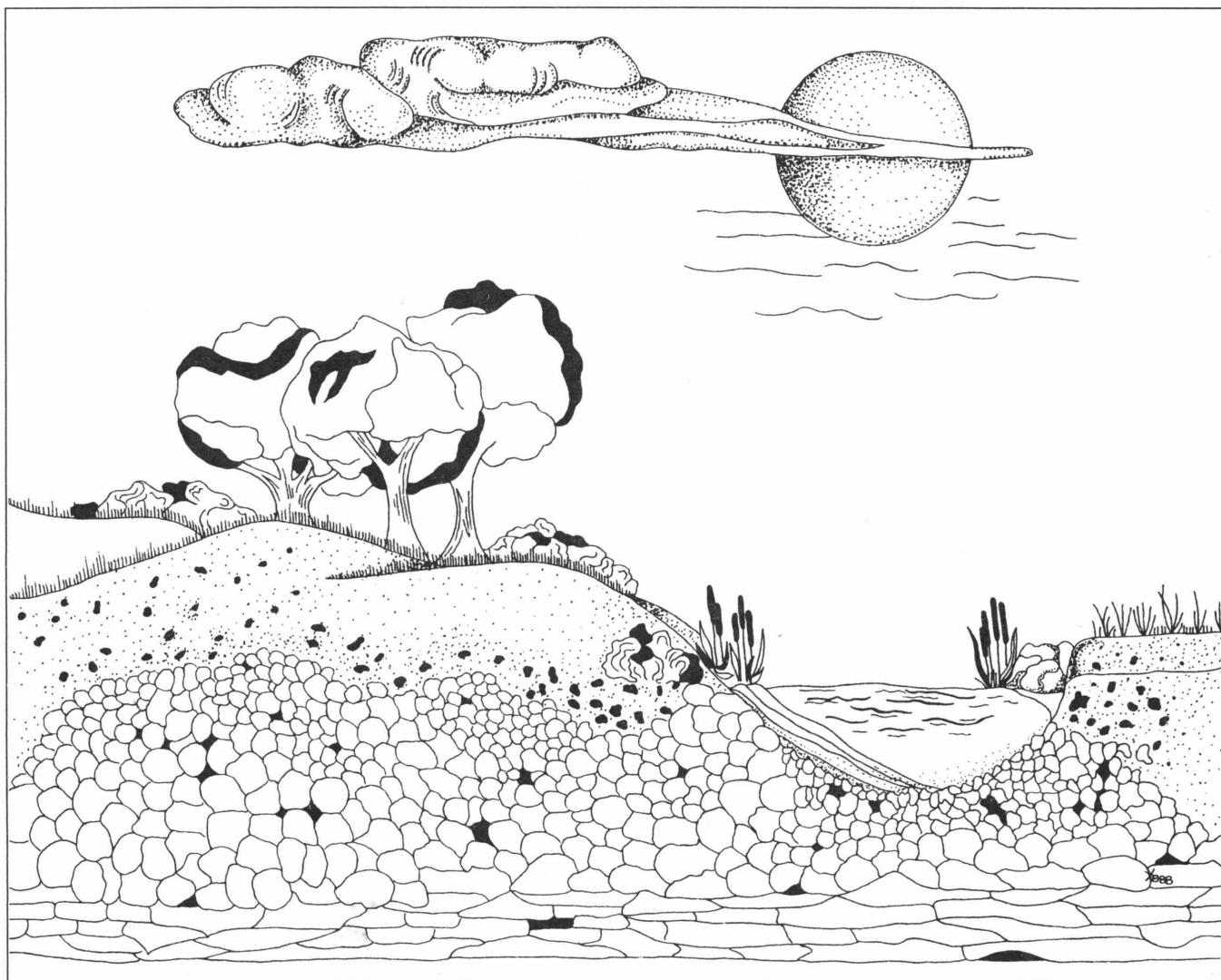

Virginia Cooperative Extension Service

Virginia Tech and Virginia State

Virginia's Land Grant Universities

Publication 426-613

1989

LD
5655
A762
no. 426-613
1989
YPI
Spec

PLANT NUTRITION

Plants need 17 elements for normal growth. Carbon, hydrogen, and oxygen are found in air and water. Nitrogen, potassium, magnesium, calcium, phosphorus, and sulfur are found in the soil. The above six elements are used in relatively large amounts by the plant and are called macronutrients. There are eight other elements that are used in much smaller amounts and are called micronutrients, or trace elements. The micronutrients, which are found in the soil, are iron, zinc, molybdenum, manganese, boron, copper, cobalt, and chlorine. All 17 elements, both macronutrients and micronutrients, are essential for plant growth.

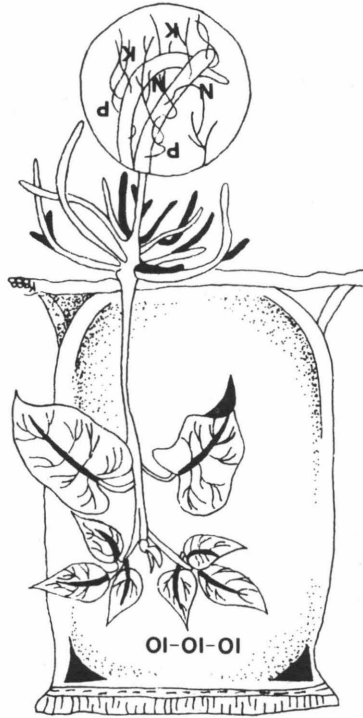

MACRONUTRIENTS	DEFICIENCIES	REMARKS
Nitrogen (N) - Part of proteins, enzymes, chlorophyll, and growth regulators.	Reduced growth, yellowing (chlorosis), reds and purples may intensify with some plants, reduced lateral breaks.	Excess will yield all leaf and stem growth, with little fruit.
Phosphorus (P) - Role in fat, carbon, hydrogen, and oxygen metabolism; respiration and photosynthesis.	Reduced growth, color may intensify, foliage turning brown or purple in some plants; thin stems, loss of lower leaves, reduced flowering.	In very acid or alkaline soils, phosphorus will be unavailable.
Potassium (K) - Important in starch formation, sugar translocation, water relations, disease resistance, chlorophyll development, and tuber formation.	Reduced growth, shortened internodes, marginal burn or brown leaf edges, dead spots in the leaf, reduction of lateral breaks, and tendency to wilt readily.	Large amounts of potash are needed by most plants.
Magnesium (Mg) - Part of chlorophyll, enzyme activator; important in energy utilization.	Reduction in growth; yellowing between veins, also can occur with middle or lower leaves; reduction in seed production.	Interferes with calcium uptake if used in excess.
Calcium (Ca) - Important in cell wall structure, cell division, enzymes, and as an enzyme activator.	Inhibition of bud growth, death of root tips, cupping of mature leaves, weak growth.	Too much calcium will result in high pH, causing many of the micronutrients to become unavailable to the plant.
Sulfur (S) - Part of protein, amino acids, vitamins; important in respiration.	Symptoms are a general yellowing of the affected leaves of the entire plant.	In Virginia, acid rain discharges 10 pounds of sulfur per acre to the soil each year.

When you're providing those extra nutrients for your plants, be sure to measure fertilizers accurately and apply them safely. Fertilizer run-off ends up in nearby streams and ultimately upsets the water quality in your community.

JANUARY

UNDERSTANDING FERTILIZERS

Fertilizers are not plant food! Although it is common practice to call them plant foods, this is a misnomer. Plants produce their own food using water, carbon dioxide, and energy from the sun.

Plant nutrients consist of 17 elements essential to plant growth. Nitrogen, phosphorous, and potassium are considered fertilizer macronutrients because plants require them in larger quantity for maximum growth.

Fertilizer Analysis

All fertilizers are labeled with three numbers. These three numbers give the percentage by weight of nitrogen (N), phosphate (P_2O_5), and potash (K_2O). Nitrogen is important for leaf and stem growth and provides the rich green color in a plant. Phosphorous (derived by the plant from phosphate) provides for root and flower growth. Potassium (derived by the plant from potash) helps build plant tissue and aids the production of chlorophyll.

A fertilizer is said to be complete when it contains nitrogen, phosphorus, and potassium. Examples of commonly used fertilizers are 10-10-10, 16-16-16, and 20-10-5. An incomplete fertilizer will be missing one of the major components.

Slow-release fertilizers release nutrients (make them available to the plant) over an extended period. Caution is needed when slow release fertilizers are applied around trees or shrubs, as the later nutrient release may keep the plants growing into the fall when they should be hardening off for the winter.

Cottonseed meal, blood meal, bone meal, hoof and horn meal, fish emulsion and all manures are examples of organic fertilizers. Organic fertilizers usually contain relatively low concentrations of actual nutrients, but they perform other important functions which the synthetic formulations do not. These functions include: increasing organic content of the soil, improving physical structure of the soil, and increasing bacterial and fungal activity.

Effects of Over-Fertilizing

Fertilizers are salts, much like our familiar table salt except that they contain various plant nutrients. If tender plant roots are close to the fertilizer granules, water is drawn from these roots. Plant cells in these roots begin to dehydrate and collapse, and the plant roots are "burned" or dried out to a point where they cannot recover.

It is important to apply fertilizer according to instructions AT THE PROPER TIME AND RATE to prevent water quality problems. Avoid getting fertilizer on sidewalks and driveways where it can easily wash into storm drains and, eventually, into creeks, streams, and rivers. Nutrients, particularly nitrogen, become a water quality problem through leaching or run-off. Leaching is the effect of nutrients being washed through the lower soil layers and into the groundwater supply. Leaching and run-off not only rob your soil of nutrients, but also lead to erosion. Provide your soil with holding power by planting groundcovers in bare spots.

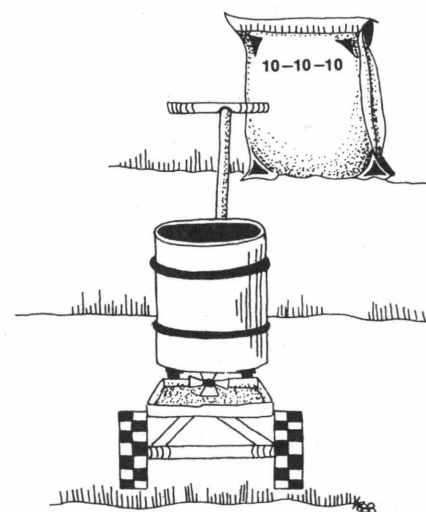

FEBRUARY

EROSION CONTROL

Soil erosion is a major consequence of storm run-off from unprotected areas. Sediment constitutes the largest volume of contaminant carried by run-off. Most of the phosphate and pesticides entering waters are attached to soil particles. Therefore, controlling erosion will make a significant contribution to the control of water pollution.

The erosion process is initiated when the impact of falling raindrops or irrigation water detaches soil particles. When there is too much water to soak into the soil, it fills surface depressions and begins to flow. With sufficient velocity, this shallow surface run-off carries away the detached soil particles.

Signs of Erosion

- * Tree roots, small stones or rocks becoming exposed.
- * Small rills or gullies beginning to show.
- * Build-up of silt in certain low areas.
- * Soil splashed on windows and outside walls.
- * The widening or deepening of stream channels.



This destructive process can be controlled by reducing the quantity and velocity of run-off through the use of groundcovers. Groundcovers include any plant material that covers the ground surface so that the soil cannot be seen from above and rain does not strike directly upon it. Turfgrass is one important type of groundcover, but many other low-growing plants are used this way. These include herbaceous perennial plants and low shrubs. Besides controlling erosion on slopes, the groundcovers fulfill other important functions as follows:

- * Conserve soil moisture and lower soil temperatures during periods of extreme heat.
- * Utilize nutrients in the soil for plant growth, which otherwise could be lost to erosion and leaching.
- * Reduce lawn maintenance and fill narrow, odd-shaped areas where mowing and edging might be difficult.
- * Obstruct foot traffic without impeding view.
- * Produce interesting patterns with variation in height, texture, and color.

Significant maintenance is necessary for the first one to three years until the groundcover becomes established. Provide regular cultivation and use of organic mulch to control weeds, fertilization to encourage vigorous growth for good cover; irrigation in times of drought; and disease and pest control.

Sod is the most common groundcover. The fibrous roots of turf grasses firmly hold the surface soil and absorb water. Sod also benefits the soil by adding organic matter to improve soil structure and infiltration of water and air.

Newly cut banks and any slopes greater than 12 percent are best treated with groundcover plantings other than sod, to reduce maintenance. Around buildings, ground covers are superior to paving or structural controls for reducing heat, glare, noise, and dust.

MARCH

ENHANCE YOUR LAWN HEALTH

Bagging grass clippings and throwing them out with the trash robs your lawn of valuable nutrients. Grass clippings from a properly mowed lawn are a fertilizer resource. Left on the lawn after mowing, the clippings reduce the amount of fertilizer needed for a healthy lawn. Leaving grass clippings on the lawn also saves your local government the cost of disposing of them at area landfills. During peak growing periods, usually in April, it may be necessary to collect grass clippings. If you must gather up the clippings, consider adding them to your yard's compost pile for later use as mulch.

Get a Free Soil Test

Before you plant grass seed or fertilize your lawn, get a free soil test kit from your local Extension Office, dig up a soil sample, and have it tested by the Extension Service. The soil report will tell you in plain language whether you need to apply lime to restore the soil's natural chemical balance. It will also tell you what kind of fertilizer is needed and how much you should use.

Mow Regularly

Proper mowing is as important to the success of a well-kept lawn as any other step. Although recommended cutting heights vary by type of grass, a good "rule of thumb" is to cut off no more than one-third of the grass plant at any mowing. Set the mower height accordingly, but no lower than 1-1/2 inches. Weekly mowing should be often enough except in April and May, the months of peak grass growth.

Fertilize in the Fall

Fall fertilizer applications are most beneficial to the cool season lawn grasses found in Virginia. Apply the amounts of lime and fertilizer nutrients (nitrogen, phosphorus, and potassium) recommended in your soil test report. Applications of fertilizers containing nitrogen should be made from September through December. By leaving grass clippings on the lawn, it is estimated that you will reduce nitrogen applications 20 to 30 percent after the first year and 35 to 45 percent after the second year.

Water as Needed

Except during the most severe drought, grasses common to Virginia will survive without watering. If you wish to maintain a green yard in dry weather, add about 1 inch of water a week, preferably in the early morning and only as much as will soak into the ground. Water that is allowed to run off carries with it nutrients that are valuable to the lawn but harmful to streams and reservoirs.

By following these guidelines, homeowners in Virginia can expect to save money on fertilizer as well as plastic trash bags. Annual homeowner savings for a typical quarter-acre lot amount to \$20 to \$45 in fertilizer costs and \$20 to \$40 for plastic bags. In addition, you will help your local government keep a lid on refuse disposal costs. A typical quarter-acre lot generates 3,500 to 4,000 pounds of grass clippings a year. Disposing of them costs the homeowner \$50 to \$90 a year in public service charges, private collector fees, or taxes.



APRIL

TILLING THE SOIL

Tilling your garden correctly preserves the soil and its fertility, enhancing the absorption of rainfall and protecting local streams from run-off sediment.

Gardeners often wonder whether to do the plowing or tilling in the spring or in the fall. Working the soil in fall is far more beneficial than traditional spring plowing. It allows earlier spring planting, since the basic soil preparation is already done when spring arrives. The turning under of large amounts of organic matter is likely to result in better decomposition when done in the fall, since autumn temperatures are higher than those of early spring, and there is more time for this process to take place. Insects, disease organisms, and perennial weeds may be reduced by killing or inactivating them through burial or root exposure to harsh winter weather. Also, snow is trapped between the hills of roughly-plowed soil, so more moisture is retained than on flat, bare ground. Incorporation of limestone or rock fertilizers in the fall gives them time to interact chemically with the soil and influence spring plant growth.

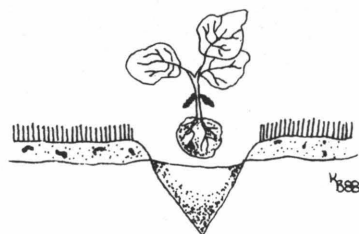
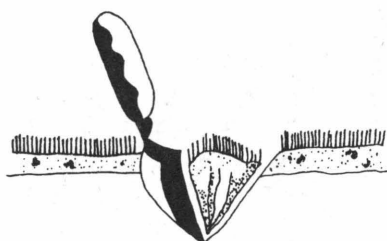
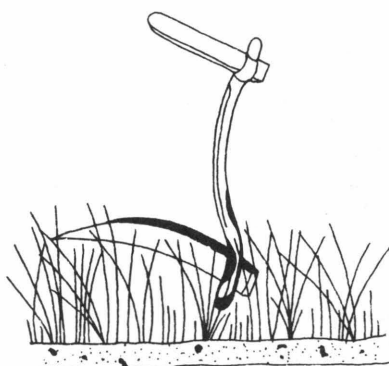

Fall plowing alone is not recommended for hillside or steep garden plots, since soil is left exposed all winter, subject to erosion when spring rains come. For these areas, a winter cover crop is grown to improve soil and prevent erosion. Till in the fall to prepare the soil for seed, and in the spring turn under the green manure. Spring plowing is better for sandy soils and those where shallow tilling is practiced. Generally, most gardens must be lightly tilled in the spring to kill weeds and smooth the soil for planting.

An alternative to standard procedures is minimum-till gardening, also known as conservation tillage. This method is ideal for transplants to the vegetable garden.

1. In the fall, prepare the soil for cover crop seed by tilling under summer crop wastes. Remove tomato vines and corn stalks to make tilling easier.
2. Plant a combination cover crop of rye-hairy vetch (2 pounds of winter rye grain and 3/4 pound of hairy vetch per 1000 square feet). The rye, a non-legume, provides the mulch for spring planting. Hairy vetch, a legume, contributes beneficial nitrogen to the soil. The vetch seed must be coated with a Rhizobium innoculant prior to seeding to insure nodulation with nitrogen-fixing bacteria.
3. In the spring, use a scythe or string-line trimmer to cut the crop cover to a manageable level. Rake the cover crop to the side of the area to be planted and save. Use a lawn mower to completely trim to the ground.
4. A week later, mow the area again. Now your area is ready for planting. Dig a hole for each plant, large enough to accommodate for root spread. Pull weeds in the surrounding area including cover crop roots. Water in the plants with a water-soluble fertilizer according to directions or, if available, put a quart of compost in each hole with the plant. Mulch the entire area between plants with the clippings reserved from the week before. Leave 6 to 8 inches of space around the base of plants to allow the soil to warm up.
5. Some additional mulch may be needed for proper weed control. Use grass clippings or leaves saved from the previous fall. If weeds appear, pull them by hand. If hoeing is needed, try to keep the blade underneath the mulch layer and disturb as little as possible.
6. This process is repeated the following fall to continue minimum-till gardening. You may want to experiment with small plots rather than your entire garden.

MAY

FERTILIZING YOUR VEGETABLE GARDEN

Fertilizers are designed to supplement the nutrients already present in your soil. Too much fertilizer can damage roots, and the excess can reach your local stream, leading to water pollution problems.

Timing of Fertilizer Application

Some crops require more of some nutrients than others. Root crops require less nitrogen fertilization than leafy crops. Corn is a heavy feeder and may require nitrogen fertilization every four weeks. A general rule of thumb is that nitrogen is for leafy top growth; phosphorus is for root and fruit production; and potassium is for cold hardiness, disease resistance, and general durability.

Proper use of nutrients can control rate and character of plant growth. Nitrogen is the most critical nutrient in this regard. If tomatoes are fertilized heavily with a nitrogen fertilizer into the summer, the plants may be all vine and no fruit. This is also the case with potatoes, which will show excess vining and poor tuber formation. If slow-release fertilizers or heavy amounts of manure are used on crops that form fruit or vegetables, it will keep the plant producing leaf or vine growth, and fruit or vegetable development will occur very late in the season.

Remember that a nitrogen application will have its greatest effect for three to four weeks after application. If tomatoes are fertilized heavily on June 1, there may be no flower production until July 1, which will delay fruit ripening in late August. For this reason, it is important to plant crops with similar fertilizer needs close together to avoid improper rates of application.

Application Methods

Broadcasting. A recommended rate of fertilizer is spread over the growing area and left to filter into the soil, or incorporated into the soil with a tiller or spade.

Banding. Narrow bands of fertilizer are applied in furrows 2 to 3 inches from the garden seeds, and 1 to 2 inches deeper than the seeds or plants that are to be planted. If the fertilizer band is placed too close to the seeds, it will burn the roots of the seedlings. For plants widely spaced, such as tomatoes, fertilizers can be placed in bands 6 inches long for each plant, or in a circle around the plant. Place the bands 4 inches from the plant base. Banding is one way to satisfy the needs of many plants (especially tomatoes) for phosphorus as the first roots develop. When fertilizers are broadcast and worked into the soil, much of the phosphorus is locked up by the soil and is not immediately available to the plant. By concentrating the phosphorus in the band, the plant is given what it needs, even though much of the phosphorus stays locked up.

Side Dressing. Dry fertilizer is applied as a side dressing after plants are up and growing. Scatter fertilizer on both sides of the row, 6 to 8 inches from the plants. Rake it into the soil and water thoroughly.

Foliar Feeding. Nutrients applied to foliage are absorbed and used by the plant quite rapidly. Absorption begins within minutes after application, and with most nutrients, it is completed within 1 to 2 days. Foliar feeding is best when your soil is too cold for the plants to extract the dry fertilizer. Foliar nutrition can be a supplement at a critical time for the plant, but can not replace soil fertilization.



JUNE

IRRIGATION

Adequate soil moisture is essential for good crop growth. A healthy plant is composed of 75 to 90 percent water, which is used for the plant's vital functions, including photosynthesis, support (rigidity), and transportation of nutrients and sugars to various parts of the plant.

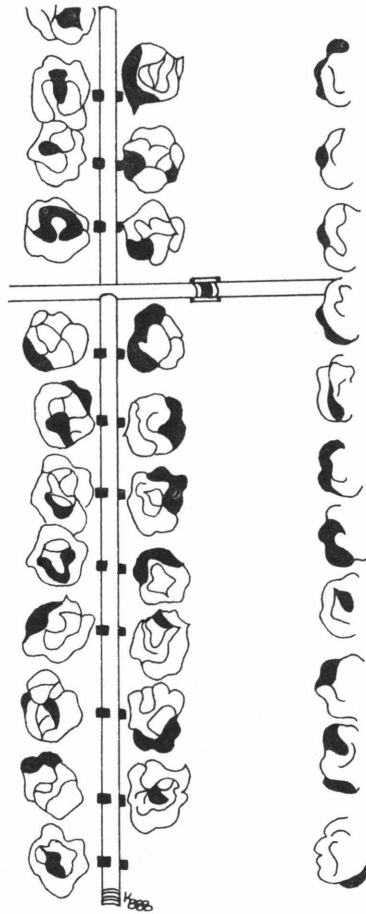

There are several options for applying water to plants. These include: a watering can, a garden hose with a fan nozzle or spray attachment for containers, small gardens or individual plants and portable lawn sprinklers, a perforated plastic soaker hose, drip or trickle irrigation, or a semi-automatic drip system for lawns and gardens.

Your careful use of irrigation techniques will help local streams and will ultimately benefit larger bodies of water in your surrounding area by reducing fertilizer and pesticide run-off and conserving water.

Some Basic Techniques and Principles for Watering

- * Adjust the flow or rate of water application to about 1/2 inch per hour. Much faster than this will cause run-off. To determine the rate for a sprinkler, place small tin cans at various places within the sprinkler's reach, and check the level of water in the cans at 15-minute intervals.
- * When using the oscillating type of lawn sprinkler, place the sprinkler on a platform higher than the crop to prevent water from being diverted by plant leaves. Try to keep the watering pattern even by frequently moving the sprinkler and overlapping about 1/2 of each pattern.
- * Do not sprinkle foliage in the evening. Wet foliage overnight may encourage disease. Morning watering is preferred.
- * Perforated plastic hoses or soaker hoses should be placed with holes down (if there are holes), along one side of the crop row or underneath mulch. Water will slowly soak into the soil.
- * Frequent, light waterings will only encourage shallow rooting causing plants to suffer more quickly during drought periods, especially if mulches are not used. On the other hand, too much water, especially in poorly drained soils, can be as damaging to plant growth as too little water.

Your lawn can use an inch or more of water per week in hot, dry weather. The lawn should be watered when the soil begins to dry out, but before the grass actually wilts. Loss of resilience can be observed; footprints will make a long-lasting imprint instead of bouncing right back.

Critical watering periods for selected vegetables are:

Asparagus	Spear production, fern development
Broccoli, Cabbage, Cauliflower	Head development
Beans, peas	Pod filling
Carrot	Seed emergence, root development
Corn	Silking, tasseling, ear development
Eggplant, Tomato	Flowering, fruiting
Cucumber, Melon	Flowering, fruit development
Lettuce	Head development; moisture should be constant

JULY

REDUCING THE EFFECTS OF DROUGHT

One of the times you are most counted on is during a drought. Follow guidelines for local water restrictions, if applicable. By your participation, you contribute to water conservation efforts and water quality in your area.

What happens to soil nutrients during a drought? The good news is - nothing. It does not change soil composition or structure. The nutrients are not lost or evaporated from the soil.

But heavy rainfall after a dry period can wash away heavy clay, and with the clay go your valuable nutrients and topsoil. This is not caused by the drought, but by the structure of clay soil; it is made up of very small particles which are easily dispersed by water. This leads to erosion and nutrient loss. There are several ways to hold on to your soil and improve nutrient quality:

- * Incorporate organic matter into clays and other soil types to improve soil structure.
- * Mulch to conserve moisture and control soil splashing.
- * Use trickle irrigation near the base of plants to reduce run-off.

Watering

There is no substitute for water during a dry spell. The correct time to water has always been a controversial issue, and the proper time to water a garden or lawn may be a bad time for most working people. Using a timed irrigation system is one of the best ways to conserve water and time, but for those who don't want to make that kind of investment, there are some general tips to follow:

The best watering time is early morning, when humidity is high and moisture loss is minimal.

Afternoon watering should be avoided. Irrigating during the day results in a 20 to 25 percent loss of water through heat and evaporation, and if foliage is watered, it can create a magnifying-glass effect that will burn leaf tissue. If a plant shows signs of drought stress in the afternoon, do apply water, but at the base of the stem.

Watering in the evening conserves water as well, but it increases the risk of fungal disease and damage from nocturnal insects searching for water.

Dormancy or Death

With sparse rainfall, the least of your worries is your lawn. Mother Nature has provided the grass plant with a built-in protection plan - dormancy. The lawn will turn brown as moisture reserves dry up, but it is far from dead. By going into a dormant state deeper than its winter dormancy, the grass plant halts the process of photosynthesis. Production of new growth is arrested. This also explains why grass grows at a slower pace in hot, dry periods. When rains do come and drought stress ends, the grass will green up, especially fescues, bluegrass, Zoysia, and Bermuda grass.

Restrict the use of herbicides because it tends to stress the lawn as it tries to detoxify the chemical. And when a lawn becomes brown during a dry spell, the last thing that is needed is fertilizer. Application of fertilizer at this time can kill your lawn. It's like telling someone who has just finished running a full marathon to run another ten miles.



AUGUST

IMPROVING YOUR SOIL

Applied correctly, a soil amendment conserves moisture, improves infiltration of rain or irrigation water, and "unlocks" existing nutrients in the soil. With this practice, nutrients are more readily absorbed into the soil and less run-off takes place.

Any addition to the soil which improves its physical or chemical condition is considered a soil amendment. Many types of amendments are available to the gardener.

Amendments to Change pH and Nutrient Levels

The correct soil pH is essential for optimum plant growth. Lime and sulfur are common amendments used to balance soil pH. Dolomitic limestone adds calcium and magnesium as it increases pH, making the soil more alkaline. Elemental sulfur will acidify soil. The amount of amendment to add depends on the current and desired pH, one good reason to have garden soil checked periodically.

Amending the soil with wood ashes raises soil pH, but you must apply twice as much ash as limestone for the same effect. Spread it in a thin layer and incorporate it into the soil. Check pH yearly if you use wood ashes. Never use coal ashes or large amounts of wood ash (no more than 20 pounds per 1000 square feet), as toxicity problems may occur.

Other amendments are added specifically to improve soil nutrient levels. Greensand and granite meal are sources of potassium. Granite meal is finely ground granite rock which releases its potassium slowly. Greensand is relatively low in potassium which is readily dissolved. Other nutritional amendments that can be purchased for garden use include cottonseed meal, kelp meal, leather meal, and worm castings, as well as an array of synthetic fertilizers.

Amendments to Improve Soil Qualities

The regular addition of manures, compost, cover crops, and other organic matter can raise the soil nutrient and structure level to a point at which the addition of synthetic fertilizers is greatly reduced, and in some cases, no longer needed. This highly desirable soil quality does not come about with a single or even several additions of organic material, but rather requires a serious, long-term program.

Animal manures are commonly used as a garden soil amendment. Fresh horse, sheep, rabbit, and poultry manures are quite high in nitrogen and may burn plants if applied directly to a growing garden. They are best applied in the fall and tilled under.

The use of compost is one way to get around tying up nitrogen during decomposition. Compost is usually made by the gardener from plant wastes. Correct composting can result in a valuable nutrient and humus source for any garden. The basis of the process is the microbial decomposition of mixed, raw, organic materials into humus - a dark, fluffy product resembling rich soil - which is then spread and incorporated into the garden soil. Contact your local Extension agent for information about building a compost pile.

Remember, your soil is alive and constantly changing. By keeping it fertile and rich, many gardening problems may be diminished. Soil is the base for plant growth, and much attention should be paid to getting and keeping it in the best condition.

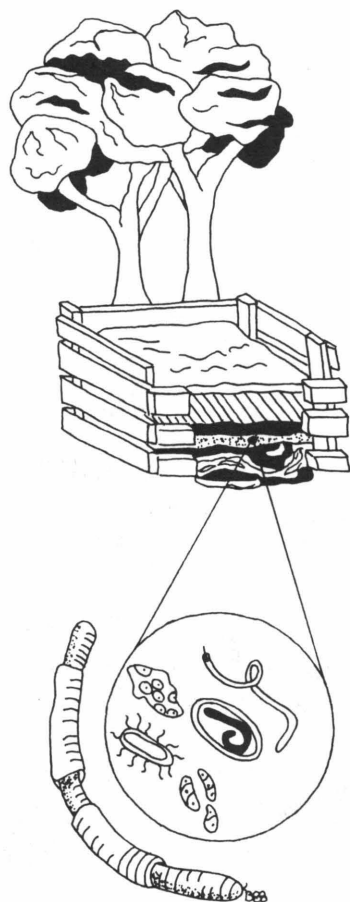

SEPTEMBER

PROTECTING SOIL IN THE WINTER

The use of cover crops reduces erosion and maintains and builds nutrients for your garden over the winter.

Turning under vegetation in the fall allows earlier planting in the spring and is especially good for heavy soils, since they are exposed to the freezing and thawing that takes place during the winter. This helps to improve soil structure. A cover crop's roots hold the soil, decreasing erosion during the winter. Tilling under the cover crop in the spring adds organic material to the soil, improving its structure and porosity and adding valuable nutrients. Winter cover crops can be planted from September 1 thru November 1 (optimum planting is September 1 to October 15). Where you have fall crops growing, you can sow cover crop seed between rows a month or less before expected harvest. This way the cover crop gets a good start but will not interfere with vegetable plant growth.

Some cover crops suitable for winter use are legumes such as crimson clover, fava beans, or hairy vetch. Non-legume cover crops such as barley, winter rye, or winter wheat may also be used with good results. Mixtures of legumes and non-legumes are effective as well. Ask at the seed store or your local Extension office what the best type of cover crop for your area is, and at what rate (pounds per 100 square feet) to plant it.

Prepare the soil for cover crop seed by tilling under plant wastes from the summer. Broadcast the seed, preferably before a rain, and rake it evenly into the soil. Spring planting may be delayed somewhat by the practice of cover cropping, since time must be allowed for the green manure cover crop to break down. If you have crops that need to be planted very early, you may prefer to cover a section of the garden with mulch.

Other Practices

Some gardeners are experimenting with various types of conservation-tillage gardening to reduce weed problems and prevent erosion and moisture loss. The standard no-till practice used on farms involves sowing a fall cover crop, killing it in the spring with an herbicide, such as paraquat, and planting vegetables in the dead sod (after a recommended waiting period). However, there are no emergent weed herbicides recommended for use in established home vegetable gardens at the present time. Use of weed-killers normally recommended for lawns or other areas is not advised, and until a safe herbicide is available for emergent weeds, this type of no-till practice is unsafe for growing vegetables in the home garden.

Another alternative is the use of a living sod, mowed regularly, which has many of the benefits of no-till and does not necessitate the use of herbicides. This practice works best with raised beds, so that only the paths need to be mowed.

Dr. John Luna at VPI & SU reports success using a combination of winter rye and hairy vetch as a fall-sown cover crop, harvesting it with a scythe in the spring, planting through the stubble, then using the top material as a mulch as the season progresses. Also, this option does not require the need for herbicides.

The use of cover crops over several seasons or years in a particularly weedy section of the garden is particularly useful in reducing weed problems and water demand.



OCTOBER

TEST YOUR SOIL

The amount of fertilizer, lime, and other amendments recommended for soil improvement should allow optimum growth without undue risk of polluting the natural run-off. It is important not to apply more than is recommended, and if time of year or season of application is a part of the recommendation, these guidelines should also be closely followed. This will assure greatest plant response with the least chance of plant damage or drainage water pollution. Fertilizer, lime, and other amendments washed off by heavy rains contribute to stream pollution.

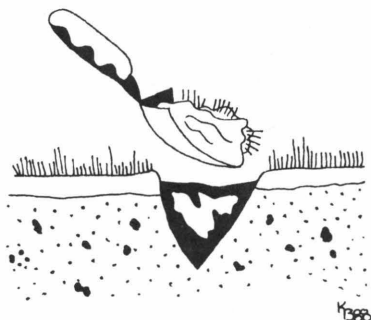
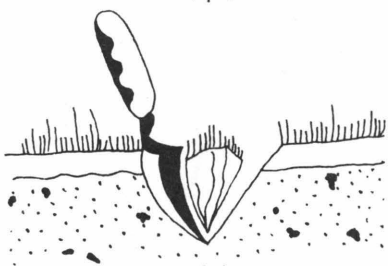
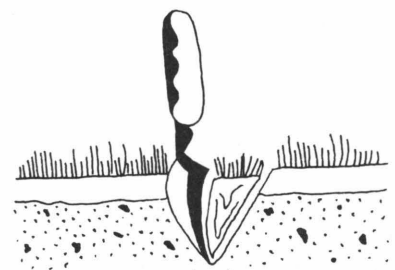

The purpose of a soil test is to supply you with enough information to make a wise fertilizer and soil amendment choice. A free soil test from Virginia Polytechnic Institute and State University will provide information on pH, available phosphorus, potassium, calcium, and magnesium. Soluble salts are run on request. The results of the soil test are mailed to you with recommendations as to what kind of fertilizer or amendment should be applied for economical growth of the desired crop or specific plant. A soil test need not be performed more often than every 3 to 4 years. Submit your sample in the fall, prior to planting or tilling, so that needed lime or other soil amendments can be changing the pH over the winter. Fertilizers should be incorporated the next spring.

Soil test kits are available for checking soil at home. For best results, carefully follow the instructions given for the soil test. Private companies also do soil testing; these give detailed reports and recommendations in many cases, but may be expensive (\$30 is not unusual).

The accuracy of the test is a reflection of the soil sample taken. Be sure your sample is representative of the area to be treated. Sample the soil from 10 random areas to the depth at which you till the garden. Avoid sampling unusual areas such as those near gravel roads, manure or compost spots, brush piles, or under eaves. Place the samples in a clean pail or container and mix the soil thoroughly, then transfer one cup of mixed soil to a container and take it to your local Extension Office. The Extension Service will mail the results to you with recommendations for correcting any deficiencies or other problems that may exist.

Soils range greatly in their properties and in their suitability for different uses. Many of the differences in the soils of Virginia relate to the geologic parent materials and the local topography.

The main soil types are sand, clay, silt, and loam. Sandy soil feels very coarse and grainy. Water drains through it very quickly. As a result, sandy soil dries out rapidly.

Clay soil is very thick, like putty. It holds water like a sponge. Clay soil does not dry out as fast as sandy soils, but when it does dry out, it becomes hard and very solid, making it quite difficult to break the soil surface with a shovel.

Silty soil is between sandy and clay soil. It holds water well but does not dry into a hard, solid mass.

Loam is the ideal mixture of sand, clay, and silt. Through the addition of organic amendments, loam can become the perfect soil for your vegetable garden.

NOVEMBER

USES FOR LEAVES

If you're lucky enough to have large trees adorning your property to provide cooling shade through the summer, you may consider yourself less fortunate in the fall, with all those leaves to be raked, bagged, and carted to the local landfill.

This year, try a different strategy. Instead of turning those leaves into garbage, turn them into a beneficial soil amendment for next year's flower and vegetable beds. Autumn leaves can be added to the home compost pile or used as mulch.

A compost pile need not take up a large part of your lawn or garden. Nor does a properly maintained compost pile have offensive odors. To contain the compost, use a 3 or 4 sided structure made of wood or wire meshing. Add any vegetable matter to it, such as kitchen discards and the autumn leaves. It's a good idea to add an occasional layer of soil and some ground limestone to aid the decomposition process. Turn the compost occasionally. By next gardening season, you'll have rich, dark compost that makes an excellent amendment to soil.

If you need only a small amount of compost, you can use a plastic trash bag to compost relatively fine material such as shredded leaves, lawn clippings, or chopped garden refuse. Make layers as in a compost pile, or mix all materials together. Add two quarts of water to dry material (one quart if it is quite moist or succulent). Tie the bag and turn it over monthly to aerate the material and distribute the moisture.

A lawn mower can be used to shred leaves. Pile the leaves a few inches high and go over them several times with the mower. Shred leaves when they are dry, to prevent blades from clogging. Shredded leaves are great to incorporate with other materials for compost making, but less effective for mulching purposes as they decompose too quickly.

Can you compost or mulch with leaves that carry disease or insects? The answer is a qualified yes. Diseased or insect-infested leaves should be used as a mulch for flowers or shrubs, not other trees. This way, even if the leaves carry disease, they won't damage other trees. If the leaves seem very infected, it may be wiser to compost them, since this can destroy many harmful organisms.

Other Valuable Uses

- * In the fall, collect leaves in bins or large piles. In spring, dig into the pile to get the matted clumps of partially decomposed leaves. Use as a mulch to keep moisture and nutrients accessible to the plant.
- * Fill the paths between raised beds now, for fewer weeds next spring.
- * Till into the soil in fall to break down by spring.
- * Fill bags with leaves and use as insulation for cold frames.
- * Use as a winter mulch on bare ground to reduce erosion.

Leaves are an excellent source of organic matter and other nutrients. The more you can add to a compost pile or use as a mulch, the less goes into an already over-used landfill. Mulching can also make the soil more workable, aid rainwater penetration, and improve moisture retention near plant roots.



DECEMBER

WINTERIZING TREES AND SHRUBS

By safeguarding your established trees and shrubs for winter, you help minimize the damage caused by surface run-off and erosion.

It is often necessary to give a little extra attention to plants in the fall to help them make it through winter and start spring in peak condition. Utilize cultural practices that will help you reduce winter damage of ornamentals.

Select hardy plants. Grow plant materials that are native or are known to be winter-hardy in your area.

Select an appropriate site. Some varieties of rhododendron, azalea, camellia, daphne, and holly need a location on the north, northeast, or eastern side of a building or other barrier where they will be protected from prevailing winds and intense winter sun.

Avoid poorly drained soil, low spots that create frost pockets, and sites that are likely to experience rapid fluctuations in temperature.

Practice late fall fertilization. Fertilize after plants are dormant but before soil temperature drops below 45 degrees F. to help prevent winter damage. Avoid late summer or early fall fertilization while plants are still active, as this stimulates late fall growth which is easily killed by freezing.

Prune at the right times. Proper pruning at appropriate times throughout the year is effective in reducing damage by ice and snow. Avoid late summer pruning which stimulates new, tender growth and reduces the supply of nutrients available to the plant through the winter.

Be sure your plants have enough water. Proper watering can be a critical factor in winterizing. If autumn rains have been insufficient, give plants a deep soaking that will supply water to the entire root system before the ground freezes. This practice is especially important for evergreens. Watering during January, February, and March, when there are warm days, is also important.

Mulch to control erosion, soil temperature, and loss of water. A two-inch layer of mulch material such as fir bark, pine needles, or wood chips will reduce water loss and help maintain uniform soil moisture around roots. Mulching also reduces freezing and thawing of the soil which heaves some shallow-rooted plants, causing significant winter damage.

Remove snow that is collecting on branches with a broom. Always sweep upward with the broom to lift snow off. When the branches are frozen and brittle, avoid disturbing them. Wait until a warmer day.

Protect newly planted trees. Bark splitting, especially dangerous on young trees, is caused by the extreme fluctuations in temperature. The afternoon sun on exposed trunks raises the temperature much higher than the air and the sudden drop at dark causes splits and cracks. It can be prevented by wrapping trunks with burlap strips or a commercial tree wrap or shading the southwest side.



SOIL COMPOSITION

Soil composition determines drainage (the ability of the soil to handle and transmit rainfall) and permeability (the rate at which soil transmits water). Soil composition, therefore, is a major factor in determining erodibility and run-off.

Soil is a mixture of rock fragments, decaying remains of plants and animals (organic matter), air, water, and micro-organisms created by the weathering effects of climate and vegetation upon rock. Soil furnishes support and nutrients for growing plants.

A desirable surface soil in good condition for plant growth contains approximately 50 percent solid material and 50 percent open or pore space. The mineral component is usually made up of many different kinds and sizes of particles, ranging from those visible to the unaided eye to particles so small that they can only be seen with the aid of a very powerful (electron) microscope.

Although most Virginia soils developed under forest vegetation, climatic differences from the south to north sides of Virginia and from sea level to the highest mountains (elevation 5,729 feet) vary considerably, and have had rather marked effects on the soils that have formed.

Most soils have three distinct principal layers or horizons. Each layer can have two or more sub-horizons. The principal horizons are: surface soil, subsoil, and parent material, collectively called the soil profile.

The surface soil is usually the coarser layer. It contains more organic matter (partially decomposed plants and animals) than the other soil layers. The organic matter imparts a grayish, dark-brownish, or blackish color to the surface horizon, the color depending largely upon the amount of organic matter present. Soils that are highest in organic matter usually give the darkest surface colors. This surface layer is usually most fertile and has the greatest concentration of plant roots of any soil horizon. The surface soil is that portion which is worked or tilled, fertilized, limed, and in which our crops are planted and grown. Rain and snow fall on the surface soil and enter the other horizons of the soil through it. Plants obtain much of their food and water from the surface soil.

The subsoil layer is usually finer and firmer than the surface soil. Subsoil colors are usually stronger and brighter; shades of red, brown, and yellow are most frequently observed. The subsoil supports the surface soil and may be considered as the soil reservoir, providing storage space for water and food for plants, aiding in regulating the temperature of the soil, and regulating the air supply for the roots of plants.

The parent material is decomposed and partially decomposed rock that has acquired some characteristics of the subsoil and retained some characteristics of the rock from which it came. This layer influences soil texture, natural fertility, rate of decomposition (and thus rate of soil formation), acidity, depth, and in some cases, topography (or lay of the land) on which the soil is formed.

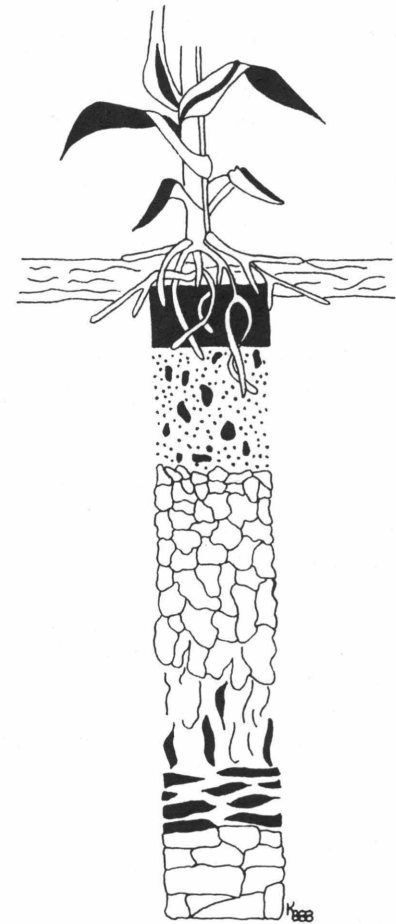

NUTRIENT MANAGEMENT AND ITS IMPACT ON WATER QUALITY

Practicing good cultural methods and nutrient management has many benefits. This guide is filled with tips that are a reminder of the ways you can help preserve water quality while helping your plants achieve optimum health and production. Watch for more information on such ideas as:

Don't bag those clippings! Returning clippings will return nutrients to your lawn.

Build a compost pile and you convert trash to treasure. Such throwaways as leaves, grass clippings, and fruit and vegetable scraps decompose into priceless organic matter.

Mulch to conserve water; during a drought, it can mean the difference between life and death to your plants.

Control erosion with the use of cover crops and groundcovers.

Use proper irrigation equipment, such as soaker hoses and water timers to reduce water consumption.

Test soil for accurate nutrient formulation for a specific plant. The test will provide you with information on pH, available phosphorus, potassium, calcium, and magnesium.

Use correct tilling procedures to lessen erosion. Tilling in the fall allows earlier spring planting, better decomposition of organic matter, and less chance for diseases, insects, and weeds since turning the soil over exposes these pests to harsh winter weather.

Mow at the proper height to protect the grass plant from stress and to preserve moisture. A good "rule of thumb" is to cut off no more than one-third of the grass plant at any mowing.

Using these and other methods from this guide will provide:

Reduced costs for you

Reduced landfill dumping

Reduced maintenance time

Increased water quality

Active utilization in these methods enables you to become an expert in your own environs and steward of clean water. For more information, contact your local Extension office for slide and video programs and publications available on nutrient management and its impact on water quality.

Cover: Water, soil, and climate support the quality of the environment. Managing your land properly helps to maintain a healthy balance.

This publication was developed and printed through a grant from the Virginia Department of Conservation and Historic Resources, Division of Soil and Water Conservation, 203 Governor Street, Suite 206, Richmond, Virginia 23219-2094.

Designed and Developed by Patricia Carry
Illustrator: Kathleen Bourke
Contributing Editor and Text Layout: Pete Madsen
Project Director: Diane Relf, Extension Specialist,
Consumer Horticulture
Assistant: Kate Dobbs

CONTRIBUTORS

Virginia Nathan, Extension Technician
John Luna, Extension Entomologist, Pest Management
John Hall, III, Extension Agronomist, Turf
Charles O'Dell, Extension Horticulturist, Commercial
Vegetable Production
George Hawkins, Extension Agronomist, Soil Fertility
Stephen Donohue, Extension Agronomist, Soil and
Plant Analysis
Alan McDaniel, Extension Vocational Horticulturist
Robert Lyons, Associate Professor
Carol Nation, Arlington County Department of Public Works

Virginia Cooperative Extension Service programs, activities, and employment opportunities are available to all people regardless of race, color, religion, sex, age, national origin, handicap, or political affiliation. An equal opportunity/affirmative action employer.

Issued in furtherance of Cooperative Extension work, Acts of May 8 and June 30, 1914, and September 30, 1977, in cooperation with the U.S. Department of Agriculture. James F. Johnson, Acting Director, Virginia Cooperative Extension Service, and Acting Vice Provost for Extension, Virginia Polytechnic Institute and State University, Blacksburg, Virginia; Clinton V. Turner, Administrator, 1890 Extension Program, Virginia State University, Petersburg, Virginia.