

Virginia Cooperative Extension Service
Extension Division
Virginia Polytechnic Institute and
State University
Blacksburg, Virginia 24061



School Dresses and Leisure Wear



4-H Member's Clothing Construction Project

Publication 346-078
Reprinted June 1982

LD
5655
A762
no. 346-078
VM1
Spec

CONTENTS

To the Parent and Leader	3
To the 4-H Member	4
Minimum Project requirements	5
Selecting your pattern	5
Fitting Your Pattern	6
Worksheet for Determining Pattern Alteration	7
Coordinating Your Fabric With the Pattern	12
Buying Your Additional Supplies	13
Learning More About Fabrics	13
Practicing What You Have Learned	13
Trying New Sewing Techniques	14
The Finishing Touches	15
Evaluating Your Garment	15
4-H Project Record Sheet	19

Virginia Cooperative Extension Service programs, activities, and employment opportunities are available to all people regardless of race, color, religion, sex, age, national origin, handicap, or political affiliation. An equal opportunity/affirmative action employer.

Issued in furtherance of Cooperative Extension work, Acts of May 8 and June 30, 1914, and September 30, 1977, in cooperation with the U. S. Department of Agriculture. Mitchell R. Geasler, Interim Dean, Extension Division, Cooperative Extension Service, Virginia Polytechnic Institute and State University, Blacksburg, Virginia 24061; M. C. Harding, Sr., Administrator, 1890 Extension Program, Virginia State University, Petersburg, Virginia 23803.

To the Parent and Leader:

This guide is designed for the 4-H member to use in continuing her learning experiences in clothing construction. The 4-H'er will gain valuable knowledge and skills that will aid her both now and in the future through the completion of activities in this 4-H project.

You can contribute to the member's development by being aware of her activities and by providing encouragement and assistance wherever necessary. Urge your 4-H'er to participate in all activities and events associated with this project and the total 4-H program. A 4-H parent needs to know what is being done and accomplished by the member. You might attend a project and a regular 4-H meeting to see how you can help the 4-H'er by providing materials for project work, by assisting with plans for demonstrations or illustrated talks, and by encouraging her to keep up-to-date project records.

You will enjoy your experiences as you help 4-H members in this project.

The Extension Clothing Specialists

To the 4-H Member:

This project, "School Dresses and Leisure Wear," is designed for 4-H members to continue their experiences in clothing. Once you have achieved the level of knowledge and skill in the beginning 4-H clothing construction project, you are ready to proceed with more intermediate techniques. The techniques or methods in this project are ones you will want to master before you move on to the next step, which is working with wool fabric. Throughout this project you will receive assistance from your parents, adult 4-H leader, and Extension Agent. They will be most willing to help you with the selection of fabrics and pattern styles as well as with particular sewing skills.

In this project, you will learn how to handle different fabrics, other than wool. In addition, you will increase your skills by constructing a variety of garments. There is no definite time limit for you to carry this project. You may carry it for more than one year. Each year you carry the project you will want to select different learning experiences so that you grow and gain knowledge with each garment you construct.

In order to profit the most from this project, you will need to follow the specific requirements for completion listed under "Minimum Project Requirements." These are "minimum" requirements and you are encouraged to do more to finish the project successfully. Complete the requirements at a pace that you and your 4-H project leader feel desirable for you so that you do your best and learn the most. After you have completed the requirements in "School Dresses and Leisure Wear" you are ready to begin the next 4-H clothing construction project, "Wool Garments."

In addition to learning new and improving old skills in the handling of fabrics through various construction details, you also will gain knowledge and experience in the proper fit of a garment, pattern alteration to achieve good fit, coordination of pattern and fabric to yourself, and of fabrics and notions that currently are available on the market.

You also will be given the opportunity to use your imagination, knowledge, and skill to share with others what you have learned by presenting a demonstration or illustrated talk to a group. This demonstration or talk can be on any topic related to your learning experiences in the project. All of the construction techniques described in this project are appropriate topics for a demonstration, an illustrated talk, or an exhibit. These presentations can be given at 4-H club meetings, Extension Homemaker Club meetings or achievement days, county and district 4-H contests, and at other events. Your adult 4-H leader or Extension Agent might be able to offer some ideas of ways to express yourself. Giving a demonstration or illustrated talk is good practice for your future role as a junior 4-H leader. For further information see "4-H Demonstration and Illustrated Talks for Senior 4-H Members."

We know you will enjoy your experiences in this project and will want to participate in all 4-H activities, including organizational club meetings and 4-H camp.

The Extension Clothing Specialist

School Dresses and Leisure Wear

4-H Clothing Construction Project

Prepared by
Barbara Laughlin

former Extension Specialist, Clothing and Textiles

Recommended by Beatrice Kalka, Extension Specialist, Clothing and Textiles

MINIMUM PROJECT REQUIREMENTS

To complete this project you will need:

1. To learn how to alter a pattern to fit your figure.
2. To complete *at least* 3 different garments which are made from 3 different types of fabrics, other than wool.

You may choose from the following lists of garments and fabrics or, with the help of your 4-H project leader, you may select others to complete the requirements.

POSSIBILITIES FOR GARMENTS

shift
jumper
shirtwaist dress
2-piece dress
pajamas and/or gown
bathrobe
beach jacket or dress
shorts and/or slacks

POSSIBILITIES FOR FABRICS

cottons
cotton blends
linen
silk
rayons
synthetics
napped fabrics or fabrics with one-way design such as corduroy, velveteen or velvet, prints, plaids

3. To model your completed garments before a group such as a Club 4-H Dress Revue, Parents' Night program, 4-H or Home Demonstration Club achievement program.
4. To share with others what you have learned by giving *at least* 1 demonstration or illustrated talk to your club or another group and by helping another 4-H member with her clothing project.
5. To keep accurate and up-to-date records of your progress and achievements.
6. To evaluate garments you make.

SELECTING YOUR PATTERN

Appearance is a very important part of every 4-H'er's life. It affects the way you feel and the impression other people form when they see you. An attractive appearance creates a pleasing impression; an unattractive one, an unfavorable impression. You can create a good effect by having clothes that are attractive and neat. One of the easiest ways to do this is through proper fit of your garments.

For a garment to fit properly, it must take the shape of the body, but never be snug or binding. Seams should be in the correct position and darts should point to and end about $\frac{1}{2}$ to 1 inch

short of the rounded part of the body. The garment should not gap at the neckline. There should be sufficient ease throughout the garment to permit unrestricted movement. A wrinkle, caused by excess fabric or strain, is an indication that the garment does not fit. Ask your adult 4-H leader for the publication on proper fit of a garment.

The first step to achieving a good fit is the proper selection of pattern size. Take your measurements again for you may have changed size since you last bought a pattern. Record your measurements.

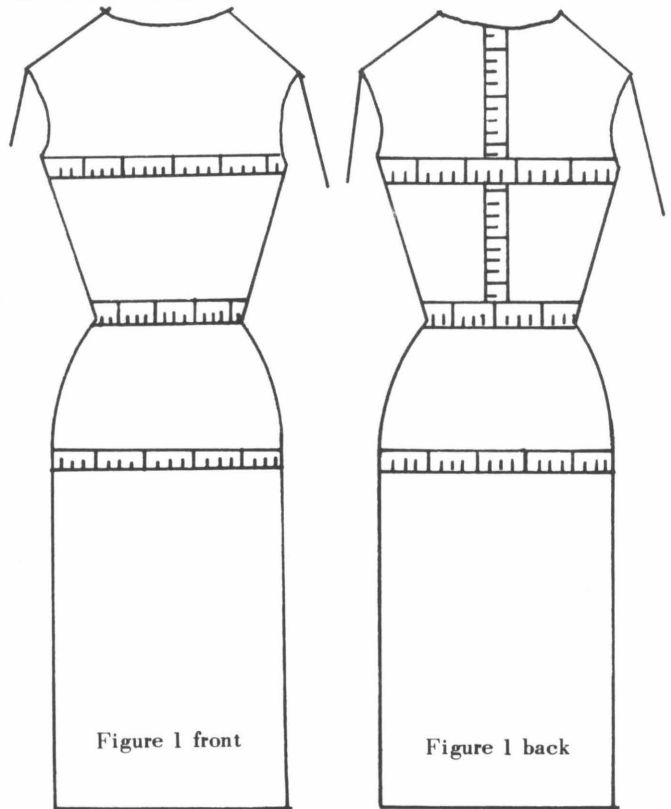

Figure 1 front

Figure 1 back

----- Bust
----- Waist
----- Hips
----- Back waist length

Check these 4 measurements with the size charts in the pattern catalogs to select the correct size and figure type for your pattern. Since the bodice is usually more difficult to fit than the skirt, you will want to select your pattern size with the bodice measurement in mind. Of course, if you are making slacks, or a straight skirt, you will select the pattern size according to waist measurement unless hips are not in proportion. In this case, select pattern size according to hip measurements.

The type of garment you choose to make first will be determined by your skill. To increase your sewing skills you will want to pay particular attention to the sequence in which you make garments. A wise idea is to begin with a simple pattern, such as a "jiffy" or "easy-to-sew" style that many commercial pattern companies feature. Increase the difficulty of sewing techniques as soon as you feel able. Don't attempt an involved pattern that requires more skill than you have until you are ready for it. For instance, a jacket dress should not be done as a first project. The

same is true of slacks. Since a good fit is so important and often difficult to achieve in slacks, it would be to your advantage to try another garment first.

No matter what type garment you select you want it to fit into your existing wardrobe. Consider your needs for clothing and whether the garments you already have meet these needs. Then you can make garments with becoming lines and colors to add to your wardrobe to make you ready for all occasions.

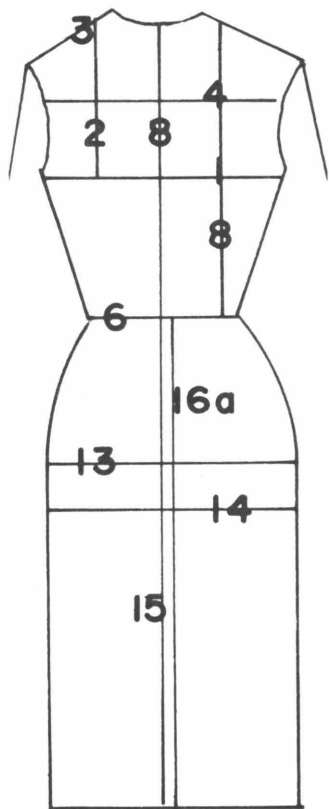

Figure 2 Front

FITTING YOUR PATTERN

Pattern companies size patterns according to "average" sizes, but very few people wear an average size. Even though you select the correct size, most likely you will need to make minor changes in the pattern to get the best fit. These changes should be made in the paper pattern before the fabric is cut.

In order to make changes, complete taking all of your measurements and record these figures on the worksheet provided in this guide. Add the necessary amount of "ease" as indicated on the worksheet to your measurements. "Ease" is merely excess length and/or width in addition to your body measurements. You need ease in order to make a garment comfortable and to prevent strain and ripping of fabric while moving and stretching.

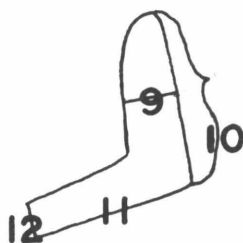

Figure 2 arm

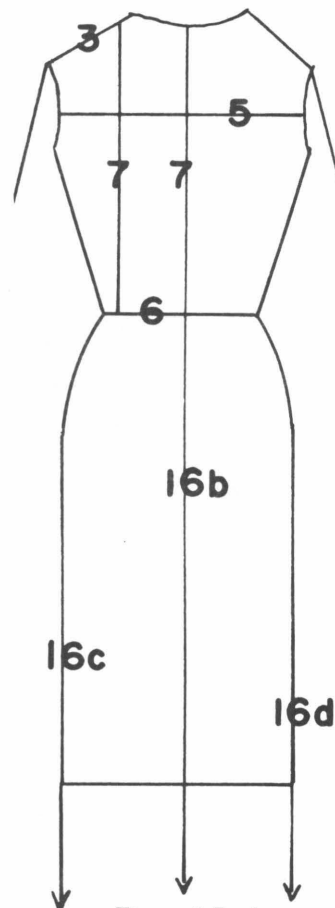

Figure 2 Back

Measure corresponding areas of the paper pattern. Be sure not to include seam and dart allowances. The difference between your body measurements, plus ease, and the paper pattern measurements will tell you where the pattern needs alteration. Complete the worksheet. Now you are ready to correct the pattern to fit your figure.

WORKSHEET FOR DETERMINING PATTERN ALTERATIONS

	Column 1 Your Measurements	Column 2 Ease Needed	Column 3 Total Amount Needed	Column 4 Pattern Measurement	Column 5 Alteration Needed
1. Bust--over full- est part		3-4''			
2. Shoulder seam to crown of bust right side		1/4''			
left side		1/4''			
3. Shoulder length- base of neck to tip of shoulder bone right side					
left side					
4. Width across chest		1/4''-1/2''			
5. Width across shoulder blades		1/2''-1''			
6. Waistline total		1/2''-1''			
front waist					
back waist					
7. Back waist length center Right side over shoulder blade		1/2''			
Left side over shoulder blade		1/2''			
		1/2''			
8. Front waist length center Right side over bust		1/2''			
Left side over bust		1/2''			
		1/2''			

WORKSHEET FOR DETERMINING PATTERN ALTERATIONS Continued

	Column 1 Your Measurements	Column 2 Ease Needed	Column 3 Total Amount Needed	Column 4 Pattern Measurement	Column 5 Alteration Needed
9. Upper arm width at fullest part with arm bent _____" from shoulder bone		2-3"			
10. Length of arm from shoulder bone to elbow					
11. Length of arm from shoulder bone to wrist					
12. Wrist circumference		Determined by style			
13. Hip--7" below waist		2" or more			
14. Hip--at largest part _____" below waist		2" or more			
15. Approximate skirt length		2-4" hem allowance			
16. Skirt length to floor					
A. Front					
B. Back					
C. Left side					
D. Right side					

Basically, there are 4 ways to alter a pattern:

1. Fold out fullness

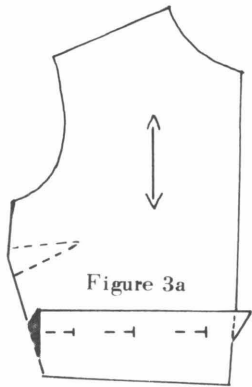

Figure 3a

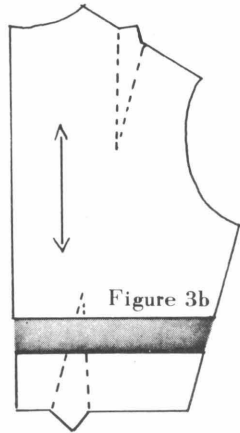

Figure 3b

3. Relocate seams

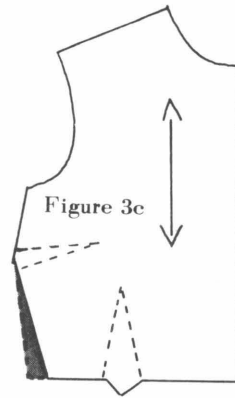

Figure 3c

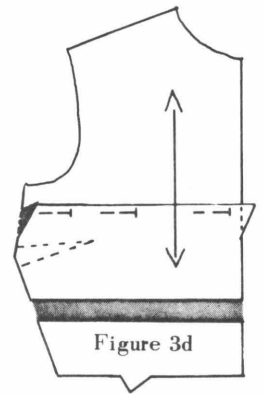

Figure 3d

2. Slash and spread to create more fullness

4. Relocate darts

Be sure the final pattern lies flat after changes have been made.

Some of the most common alterations are shown in the following illustrations.

To lengthen and shorten bodice, skirt, or sleeve draw a line parallel to floor and perpendicular to grain line.

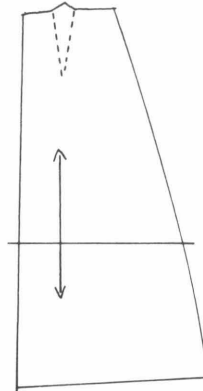

Figure 4a

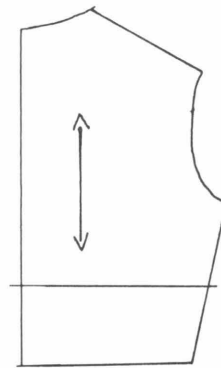

Figure 4b

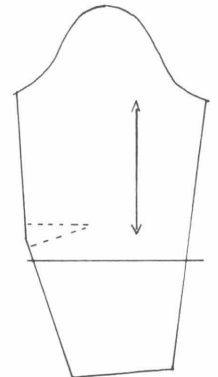

Figure 4c

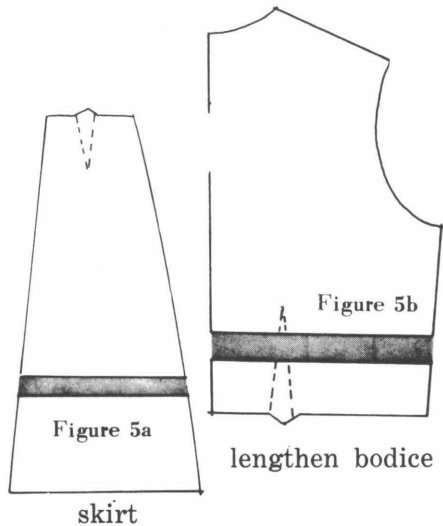

Figure 5a

skirt

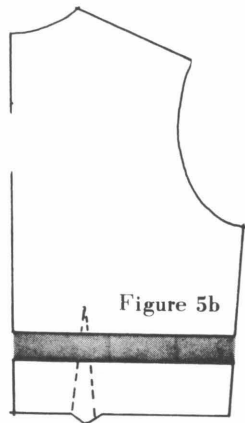

Figure 5b

lengthen bodice

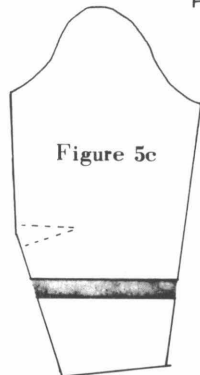

Figure 5c

sleeve

To lengthen—slash pattern on this line. Spread pattern evenly, place tissue paper behind slash, and tape in position. Be sure to make same changes on corresponding piece so seams match.

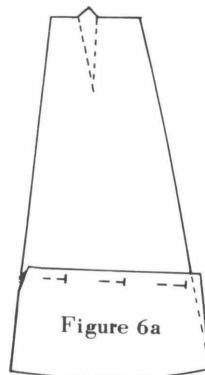

Figure 6a

skirt

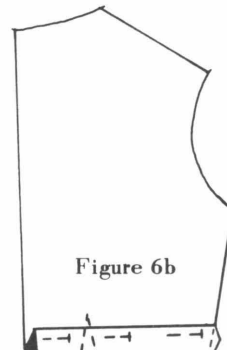

Figure 6b

shorten bodice

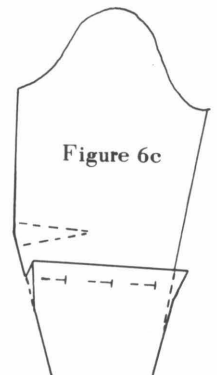
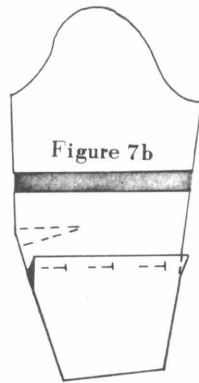
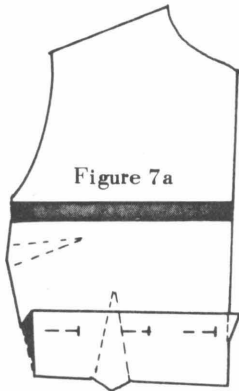

Figure 6c

sleeve

To shorten—fold pattern piece evenly on this line so that excess length is removed from pattern piece and any corresponding piece where seams must match. Straighten seam line.

To alter position of darts in bodice or sleeve— use a combination of slashing and spreading and folding out. Remember to keep original length.



To lower dart: Slash and spread above dart. Fold out below dart to keep original length.

To raise dart: Fold out above dart. Slash and spread below dart to keep original length.

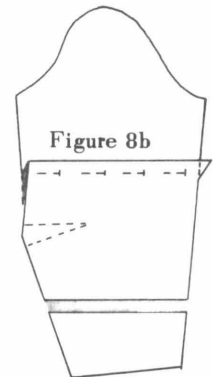
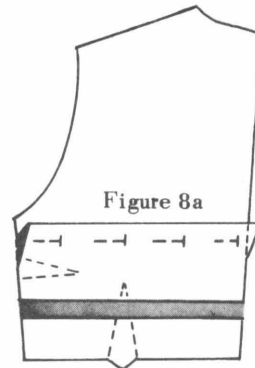

To change length of shoulder seam— slash vertically through shoulder line and across to armscye. Spread to lengthen, fold out to shorten. Straighten shoulder seam.

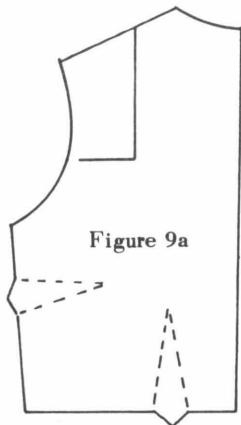

Draw lines

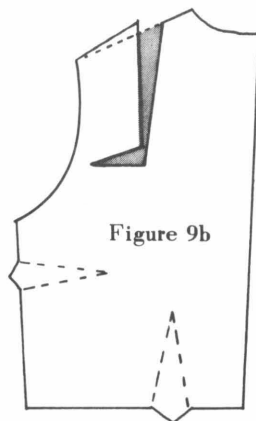

To lengthen—slash and spread

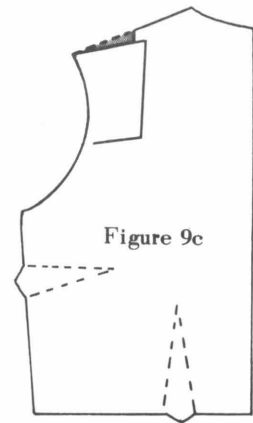

To shorten—fold out

To alter for square or sloping shoulders— relocate shoulder seam and underarm seam. Make changes on front and back bodice pieces.

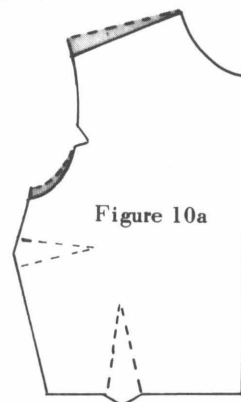

Square shoulders

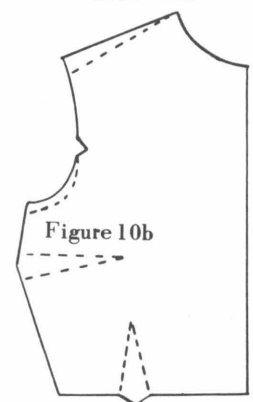

Sloping shoulders

To add or decrease waist of skirt or bodice—If difference is not greater than a total of 2 inches changes can be made by adding or decreasing at seam lines. If change is greater than 2 inches, make alterations within garment.

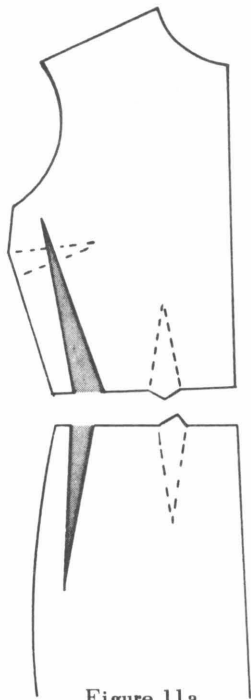

To enlarge waist:
Slash and spread

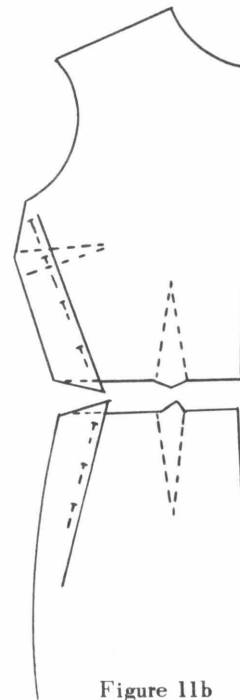

To decrease waist:
Fold out fullness

Figure 11a

Figure 11b

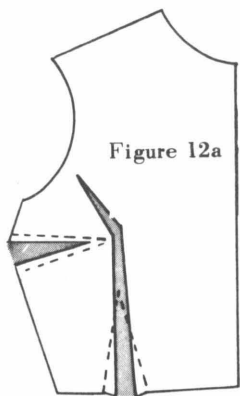

Figure 12a

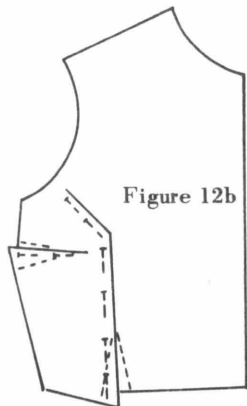

Figure 12b

To change fullness in bust—Draw lines, slash and spread to increase or fold out to decrease.

To change fullness over tummy or fanny—Draw lines, slash and spread to increase or fold out to decrease.

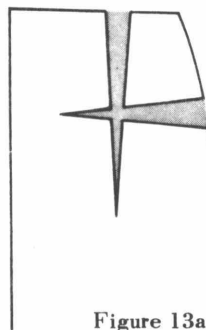

Figure 13a

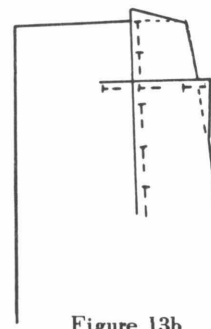

Figure 13b

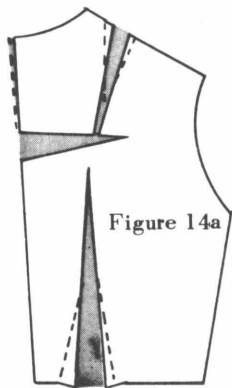

Figure 14a

To add length and fullness for round back—Draw lines, slash, and spread.

To add fullness for upper arm—Draw line, slash, and spread. Relocate sleeve cap seam.

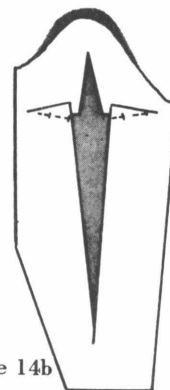

Figure 14b

To decrease length for sway back or erect back
 —Fold out fullness at center back and straighten center back seam.

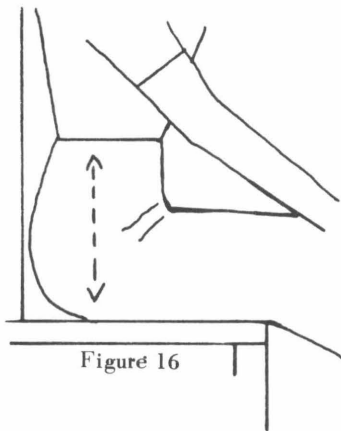

Figure 16

Pants Alteration

For average figure
 Seat person on straight chair. Measure from waistline to chair seat at side seam. Add 1/2" for ease.

To measure pattern, draw line from crotch seam line at right angles to grainline. Measure from that line to waist seam. If this pattern measurement differs from measurement of waistline to seat of chair plus ease, alter both front and back pattern pieces. Slash and spread to lengthen or fold out extra length to shorten.



Figure 15a

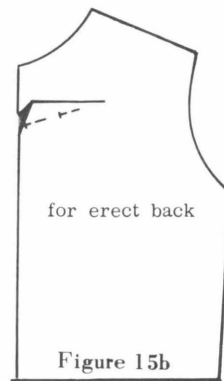

Figure 15b

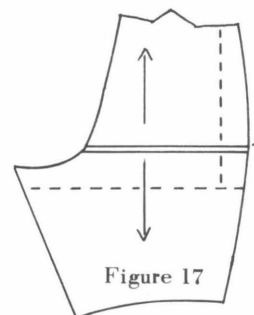

Figure 17

For round figure

Measure body while standing from center front waistline, through crotch to center back waistline. Add 3" for ease. To check pattern, measure total length of both front and back crotch seams. Do not include seam allowance.

If body measurements plus ease and pattern measurements differ, analyze figure. If round front and back, add half the amount needed to each

piece along alteration line. If more round in back or front, add proportionate amounts accordingly.

After alterations have been made in the paper pattern, make a final check for fit. Pin pattern pieces together; then pin 1/4" cotton twill tape over stitching lines. The tape gives strength to the paper pattern and permits you to try it on to check for fit.

COORDINATING YOUR FABRIC WITH THE PATTERN

Now that you have a pattern that fits, you will want to be highly selective in your choice of fabric. Choose one that is suitable for the pattern (many pattern envelopes give suggestions for fabrics to use). Certain patterns are not suitable for fabrics with diagonal designs. Other patterns require additional length for cutting out

fabrics with a nap, pile, or one-way design. Be sure to check the pattern envelope for these facts.

Choose becoming lines and colors in the fabric. If the pattern has definite lines or many seams and darts, a solid color would be a good choice. The beauty of a large printed fabric is destroyed

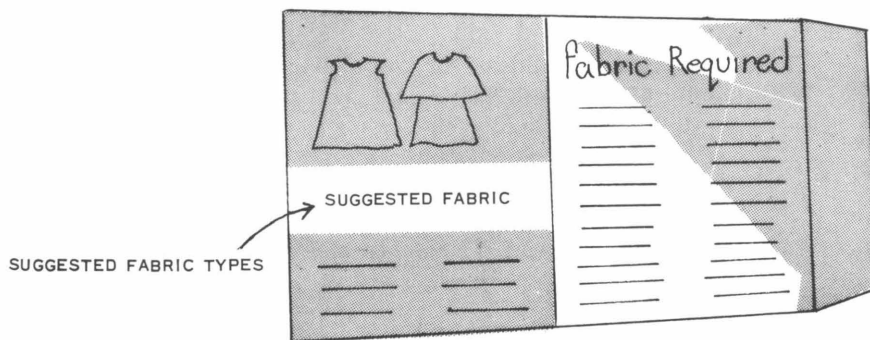

by many seams which cut the pattern of the fabric. Consider the weight and texture of the fabric before you buy. Select a style which complements the weight and texture of the fabric.

Remember, as you buy your fabric, jot down fiber content and care instructions as they are listed on the end of the bolt so you can give the finished garment the best possible care.

BUYING YOUR ADDITIONAL SUPPLIES

THREADS

For most cottons, rayons, and cotton blends on the market, a cotton mercerized thread is advisable. For silk fabrics, select silk thread. If you purchase a synthetic fabric, you might want to try sewing with one of the newer synthetic threads which are on the market. These synthetic threads have elasticity, require the same care as the garment, and are resistant to heat if the synthetic core is covered with cotton. Since these threads match the properties of the fabric you may be able to get a nicer seam. No matter what thread you select you want a nice, flat seam that will not pucker before or after laundering.

LININGS

If you decide to line your garment, look for the following qualities in a lining:

1. A fabric compatible in weight (never heavier than the outer fabric).
2. A fabric that requires the same care.
3. A fabric with the same properties and characteristics as the garment fabric.

INTERFACINGS

Certain sections of the garment such as collars, neck and sleeve facings, and areas behind buttonholes require an interfacing for support and shape. Choose a woven interfacing of a weight in keeping with the fabric and one with the same characteristics and care properties as the outer fabric. Some common woven interfacings which may be used include:

muslin	lawn
batiste	organdy
nurses linen	self-fabric
cotton broadcloth	rayon blends

Woven interfacings have similar properties to knitted and woven fabrics and more give than non-woven or iron-on interfacings. Iron-on interfacings change the feel or "hand" of the fabric and make it stiff and board-like. Because of this, woven interfacings, rather than non-woven or iron-on interfacings, are recommended. Check the pattern envelope for amounts of interfacing to buy.

LEARNING MORE ABOUT FABRICS

In this project you will learn how to handle different fabrics such as cotton and cotton blends, rayons, silks, linens, and synthetics. You might like to try a fabric that has one-way or must be cut with pieces going in one direction, such as corduroy (cotton), velveteen (cotton), velvets (rayon or silk), and some plaids and stripes. Corduroy, velveteen, and velvets must be cut with the nap or pile (raised surface) all going in the same direction, so more fabric is required. With corduroy the nap usually runs down for greater serviceability. In velvets and velveteens the pile

may run up for deeper and richer colors. If you do not cut these all in the same direction you will notice a difference in the color of pieces cut in different directions.

As you begin to put your garment together, you will practice the skills you have learned already. You might want to review "Little Virginia Miss, Unit III" to refresh your memory on certain sewing techniques. Practice these skills by using them in your garment. Construction techniques are illustrated and explained in the pattern guide sheet. Don't forget to read and follow this sheet!

PRACTICING WHAT YOU HAVE LEARNED

Now you are ready to cut your fabric. Remember the importance of proper tools and a flat, uncluttered surface to make your cutting easier and accurate. Follow the cutting layout as indicated on the pattern guidesheet for your width of fabric and the view and size of the garment you are making.

Plaids and stripes must match at construction lines to look nice. To do this usually requires extra fabric. For the best results in working with a plaid or stripe, select patterns with simple lines, few seams, and details so that matching may be simplified. For more information on sewing with plaids and stripes, look at construction books published by popular pattern companies.

TRYING NEW SEWING TECHNIQUES

As you proceed with the construction of your garments you will want to learn new techniques to increase your skills as a seamstress. If you decide to make sports or leisure wear, you might want to change from a regular seam to a flat-felled seam. A flat-felled seam can be made as follows:

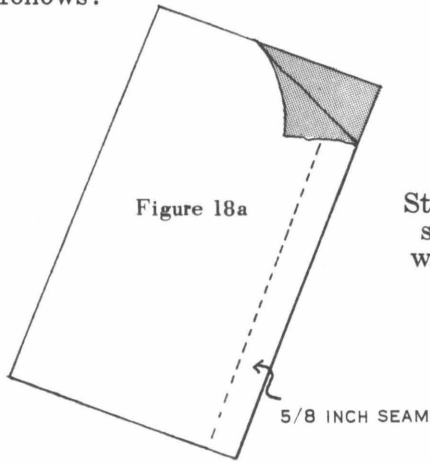

Figure 18a

Stitch in $\frac{5}{8}$ " seam with wrong sides together

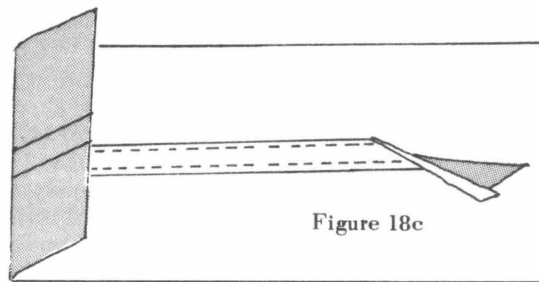

Figure 18c

Trim lower seam allowance to $\frac{1}{8}$ " and top seam allowance to $\frac{3}{8}$ "

TRIM SEAM TO $\frac{1}{8}$ INCH

TRIM SEAM TO $\frac{3}{8}$ INCH

Figure 18b

Press under $\frac{1}{8}$ " on wider seam allowance and turn over narrower, press and top stitch

If you are working on a sheer fabric the seam allowance might show through on the right side if you use a regular seam. Try a French seam to prevent this. Here's how to make a French seam.

You will want to experiment with these different types of seams on scraps of fabric before you construct a garment. To keep fabric from raveling, try various types of seams and seam finishes. Select best results for your garment.

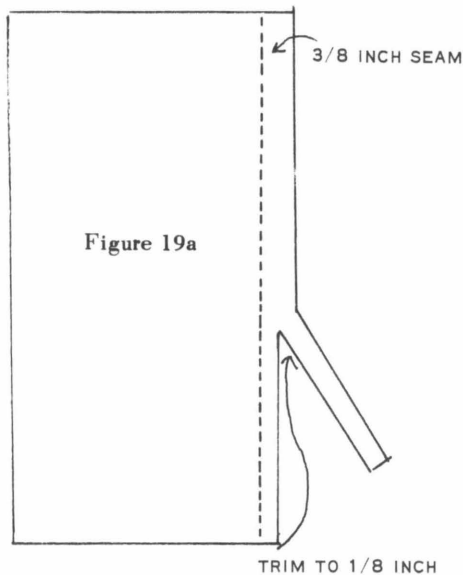

Figure 19a

Stitch in seam with wrong sides together $\frac{3}{8}$ " from edge. Trim seam to $\frac{1}{8}$ "

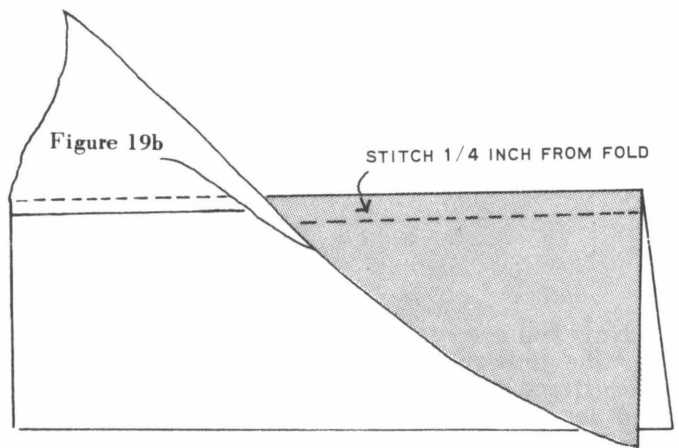

Figure 19b

Turn to wrong side; press seam allowance in one direction. Stitch $\frac{1}{4}$ " from fold on wrong side being sure to catch seam allowances.

THE FINISHING TOUCHES

To finish your garment professionally, choose a good closure. This could be a zipper, buttons, hook and thread loop, and/or snaps. Be sure you attach these neatly so the final product is both sturdy and attractive. For assistance with sewing on buttons, hooks, and snaps ask your adult 4-H project leader or Extension Agent for help.

Machine-made or hand-made buttonholes will be suitable for most dresses, blouses, and leisure wear. You will want to interface the area, mark for the buttonholes properly, and make the neat-

est buttonhole possible. If you need help, your leader or Extension Agent will provide it.

Hems should be invisible to the eye of the observer. The edge should be finished and stitches secure but not tight or drawn so that they show through to the right side. Check with your adult 4-H project leader or Extension Agent. She has access to a bulletin on methods to use in putting in hems. Try several methods and decide which gives the best appearance.

EVALUATING YOUR GARMENT

Your garment is now complete. You are proud of your becoming garment and can wear it with pride. Be sure you are as becoming and attractive as your new garment. A new outfit is not a substitute for poor grooming and a sloppy appearance. Take pride in your personal appearance. Be sure you present the picture you would like others to see when they look at you.

Let's do some checking of your total appearance.

1. Am I well groomed?
2. Are my accessories appropriate for my outfit?
3. Are the colors and lines in my garment and accessories becoming to me?
4. Is the outfit appropriate for my activities?
5. Do I have good posture?
6. Does my garment fit well?
7. Does the entire outfit go together well?

One part of learning how to construct quality garments is to know how to judge what you have done. You will want to evaluate your garment so that you can see where you did a good job of construction and selection and where you need to improve. You also will

gain valuable experiences which will assist you in future 4-H clothing projects or in serving as a junior 4-H clothing leader in your county. To evaluate each others' complete outfits use the enclosed "4-H Dress Revue Score Card for Judging."

Plan a 4-H Fashion Revue in your club so you can show others your final products. This activity is a nice conclusion to a year well spent in the clothing construction project. Be sure to invite parents and friends to this program. Members of the 4-H foods-nutrition project group could make refreshments for those attending the dress revue.

Now that you have finished the requirements for this project, you are ready to complete the 4-H project record sheet. This record will be most helpful to you later when you organize an accumulated 4-H achievement record book. It also helps you and others to evaluate your 4-H accomplishments. You have learned much in the project and have had the opportunity to practice many sewing techniques. You will want to continue your learning in the new experiences that await you in the next 4-H project, "Wool Garments."

4-H DRESS REVUE

Score Card for Judging

Name _____ County _____

Age _____ Club _____

No. Years in Clothing Project _____ Date _____

See reverse side for suggestions to consider before scoring.

FACTORS FOR SCORING	5	4	3	JUDGES' COMMENTS
I. The Girl (25 points) A. Posture B. Poise and Gracefulness C. Grooming D. Attitude E. Modeling of outfit				
II. Outfit on the Girl (40 points) A. Fabric suitable to style B. Style and fabric suitable for occasion and girl C. Color becoming to girl D. Color combination pleasing E. Accessories appropriate for outfit F. Accessories becoming to girl G. Appropriate undergarments H. Garment clean				
III. Construction as it Affects Appearance (25 points) A. Fit of garment B. Construction detail appropriate to fabric and style of garment C. Quality of construction D. Appropriate findings used E. Well pressed				
IV. Knowledge of Subject Matter (10 points) A. Shows evidence of understanding subject matter B. Construction techniques used appropriate for age and experience				

TOTAL ___ + ___ + ___ = _____

Final Rating: Blue Red White (Circle Appropriate One)

POINTS TO CONSIDER WHEN JUDGING 4-H DRESS REVUE

I. The Girl (25 points)

- A. Posture--Stands tall with head erect, chest and rib cage high, stomach flat and knees relaxed. Maintains a graceful and flattering position with weight balanced on both feet.
- B. Poise--Girl appears to be at ease and wears garment to best advantage. Answers questions with confidence and is free from excess gestures.
- C. Grooming--Clean and neat hair, well-groomed nails. Shoes clean and well polished.
- D. Attitude--Presents outfit with pride, smile. Pleasing relation with audience. Personality revealed.
- E. Modeling of Outfit--Walks correctly with poise, good posture, and a smile. Turns gracefully and slowly so that garment details can be seen.

II. Outfit on the Girl (40 points)

- A. Fabric suitable to style--Fabric texture, weight and design are appropriate for design of garment.
- B. Style and fabric suitable for occasion and girl--Style and fabric becoming to the individual and suitable for intended purpose.
- C. Color becoming to girl--Color becoming to the individual's personal coloring, figure and personality.
- D. Color combination pleasing--Color combinations used in garment and accessories pleasing and becoming.
- E. Accessories appropriate for outfit--Accessories suitable to outfit and for intended purpose.
- F. Accessories becoming to girl--Style, color, texture of accessories, including hats, gloves, jewelry, shoes and hose, becoming to girl.
- G. Appropriate undergarments--Undergarments appropriate for the individual and the garment.
- H. Garment clean--Garment is clean, free from stains, body soil and is generally neat and well pressed.

III. Construction as it Affects Appearance (25 points)

- A. Fit as it relates to appearance--Enough ease to permit body movement but snug enough to stay in position on figure. Design lines of the garment fall becomingly on the figure.
- B. Construction detail appropriate to fabric and design of garment--consider grainline, seams, darts, pleats, gathers, closures, facings, collars, sleeves, and hem.
- C. Quality of construction--Quality of construction techniques gives a pleasing and well-made appearance to garment.
- D. Appropriate findings used--Consider buttons, thread, zipper, linings, and interfacings when needed.
- E. Well pressed--Correct pressing method used during construction of garment.

IV. Knowledge of Subject Matter (10 points)

- A. Shows evidence of understanding subject matter--Girl shows evidence through conversation that she has an understanding of why she has chosen outfit and construction techniques used.
- B. Construction techniques used appropriate for age and experience--Girl has chosen to make a garment that was not too difficult for her age and experience, yet has chosen one that presents some challenge and new learning experiences.



School Dresses and Leisure Wear

4-H Clothing Construction Project Record Sheet

(Give your completed record to your adult 4-H project leader)

Name _____ Age _____ Date _____

Address _____

4-H Club _____ Leader _____

Parents' Name _____

Parents' Address _____

List 4-H offices held and committees worked on in 4-H _____

Number of 4-H meetings attended this year _____. List other 4-H events and activities, such as achievement programs, parents' night programs, contests, 4-H camps, exhibits, etc. in which you participated. (Include any awards or ribbons received.)

List the garments you have made to complete the requirements for this project:

Garment	Fabric	Approximate Cost
---------	--------	------------------

What demonstration(s) or illustrated talk(s) did you give to your club or another group? List topics and groups to which they were given.

What are your plans to continue in the clothing project next year?

Tell the most important things you learned in this project.

School Dresses and Leisure Wear

4-H Clothing Construction Project Record Sheet

(Give your completed record to your adult 4-H project leader)

Name _____ Age _____ Date _____

Address _____

4-H Club _____ Leader _____

Parents' Name _____

Parents' Address _____

List 4-H offices held and committees worked on in 4-H _____

Number of 4-H meetings attended this year _____. List other 4-H events and activities, such as achievement programs, parents' night programs, contests, 4-H camps, exhibits, etc. in which you participated. (Include any awards or ribbons received.)

List the garments you have made to complete the requirements for this project:

Garment	Fabric	Approximate Cost

What demonstration(s) or illustrated talk(s) did you give to your club or another group? List topics and groups to which they were given.

What are your plans to continue in the clothing project next year?

Tell the most important things you learned in this project.

