



US006870673B2

(12) **United States Patent**
Cromer et al.

(10) **Patent No.:** **US 6,870,673 B2**
(45) **Date of Patent:** **Mar. 22, 2005**

(54) **METHOD AND OVERHEAD SYSTEM FOR PERFORMING A PLURALITY OF THERAPEUTIC FUNCTIONS WITHIN A ROOM**

(75) Inventors: **Archie E. Cromer**, Harwood, MD (US); **Bonnie K. Johnson**, Washington, DC (US)

(73) Assignee: **Virginia Tech Intellectual Properties, Inc.**, Blacksburg, VA (US)

(*) Notice: Subject to any disclaimer, the term of this patent is extended or adjusted under 35 U.S.C. 154(b) by 0 days.

4,939,582 A	*	7/1990	Holdredge et al.	348/836
5,038,254 A		8/1991	Fabbri et al.	
5,064,161 A		11/1991	Anderson	
5,073,825 A	*	12/1991	Holdredge et al.	348/836
5,086,375 A		2/1992	Fabbri et al.	
5,160,193 A	*	11/1992	Fabbri et al.	362/33
5,272,608 A		12/1993	Engle	
5,293,305 A		3/1994	Koster	
5,295,051 A		3/1994	Cowling	
5,501,042 A		3/1996	Gustavson et al.	
5,508,764 A	*	4/1996	Oles et al.	353/98
5,528,425 A	*	6/1996	Beaver	359/629
5,528,471 A		6/1996	Green	

(List continued on next page.)

FOREIGN PATENT DOCUMENTS

(21) Appl. No.: **10/177,673**

(22) Filed: **Jun. 24, 2002**

(65) **Prior Publication Data**

US 2002/0198438 A1 Dec. 26, 2002

Related U.S. Application Data

(60) Provisional application No. 60/299,746, filed on Jun. 22, 2001.

(51) **Int. Cl.⁷** **G03B 21/56**; G03B 21/22; G03B 21/00; F21V 33/00; F21V 11/00; F21V 1/00; F21S 8/00; F21S 4/00

(52) **U.S. Cl.** **359/450**; 359/460; 353/122; 353/119; 362/147; 362/240; 362/130; 362/801

(58) **Field of Search** 359/450, 460, 359/449, 451, 443; 353/122, 119, 74-80, 7, 10, 18, 28, 29, 121; 362/147, 240, 130, 801, 804, 290; 348/121, 122, 123, 124; 434/75, 76, 432; 600/26, 27, 28, 249, 151

(56) **References Cited**

U.S. PATENT DOCUMENTS

1,249,500 A	*	12/1917	Richter	362/147
3,700,877 A	*	10/1972	Wilson	362/300
3,769,502 A		10/1973	Schultz et al.	
4,213,170 A	*	7/1980	Kimball et al.	362/267
4,485,599 A	*	12/1984	Perradin	52/222

DE	631798	6/1936
DE	3729553 A1	3/1988

Primary Examiner—Judy Nguyen
Assistant Examiner—Andrew Sever
(74) *Attorney, Agent, or Firm*—Banner & Witcoff, Ltd.

(57) **ABSTRACT**

A system and method for providing biosynchronized therapy to a patient that creates a therapeutic environment and therapeutic stimulations that are sensitive to psychological and sensory human issues, including those particular to the patient, and that reduce psychological stress experienced by the patient so that other forms of treatment provided to the patient are enhanced and benefited. In one embodiment, the environment and stimulations can be predetermined. The therapy is applied using an overhead system that includes a suspended, multi-function that performs predetermined tasks and a lighting system, both of which provide the room with natural ambient light, artificial ambient light and pre-determined task lighting. An image display system is also included for applying preselected images to the canopy over a bed of the patient. The overhead system can be used in a variety of circumstances such as a home, commercial facilities and health care facilities.

62 Claims, 11 Drawing Sheets

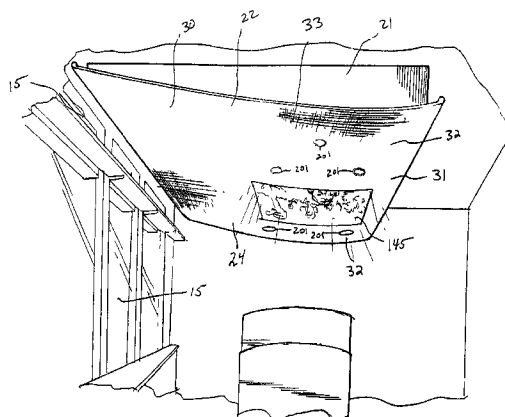

US 6,870,673 B2

Page 2

U.S. PATENT DOCUMENTS

5,676,633	A	10/1997	August		6,367,934	B1	*	4/2002	Salesky et al.	353/74	
5,681,259	A	10/1997	August		6,427,389	B1	*	8/2002	Branc et al.	52/36.1	
5,708,527	A	*	1/1998	Adamson et al.	6,443,591	B1	*	9/2002	Swensson et al.	362/147
5,725,472	A	*	3/1998	Weathers	6,554,433	B1	*	4/2003	Holler	353/79
D394,570	S		5/1998	Walters, III		6,580,559	B2	*	6/2003	Doll et al.	359/591
6,234,640	B1	*	5/2001	Belfer	2002/0191400	A1	*	12/2002	Jilk et al.	362/257
6,254,527	B1		7/2001	August								

* cited by examiner

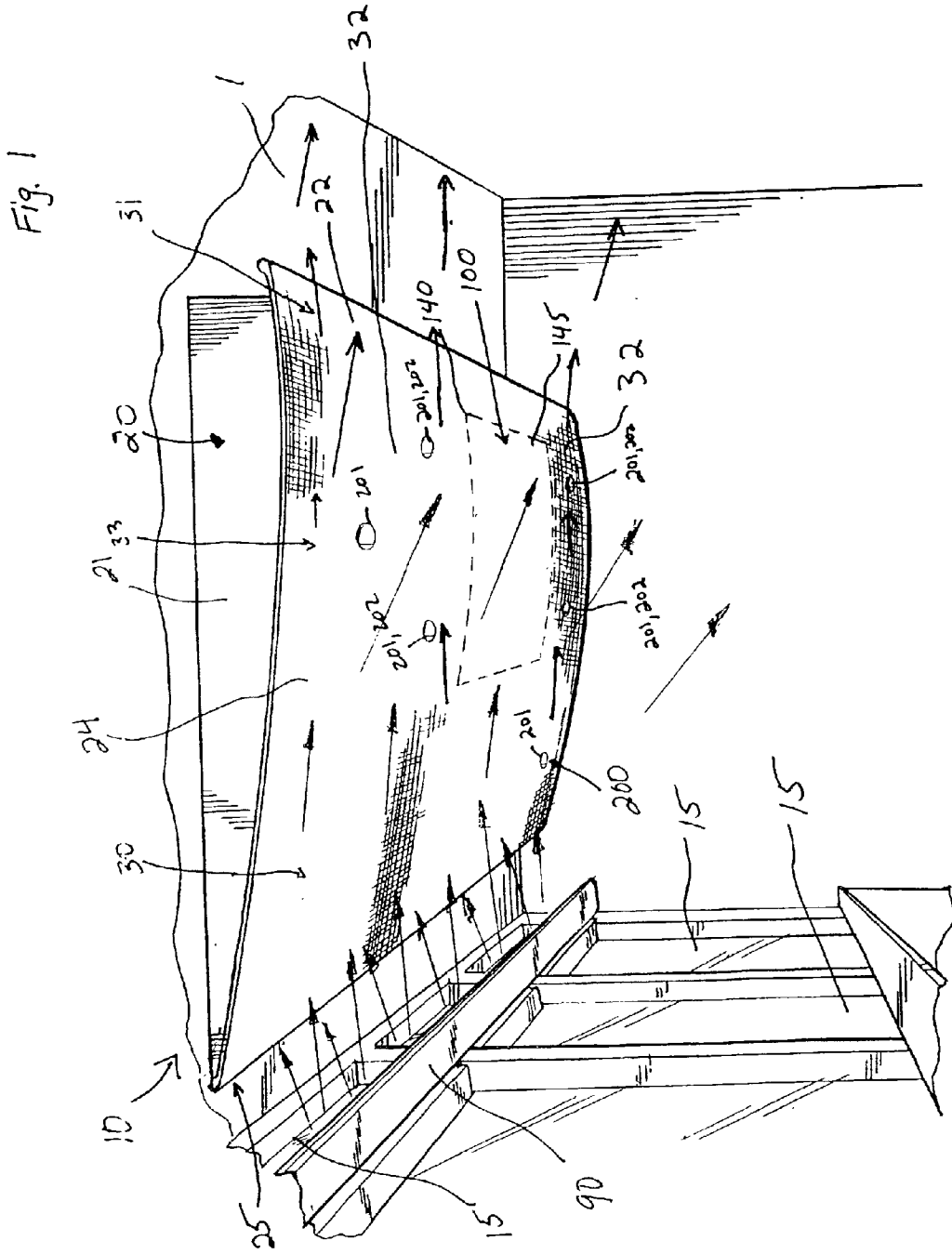

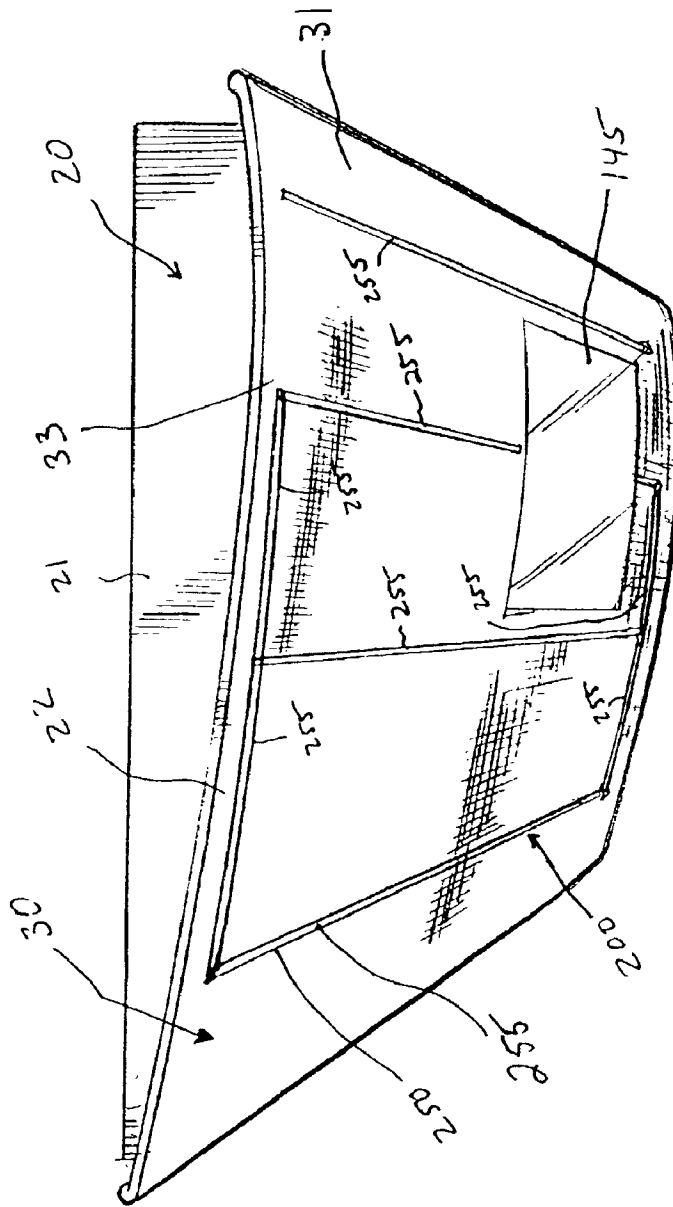

Fig. 4

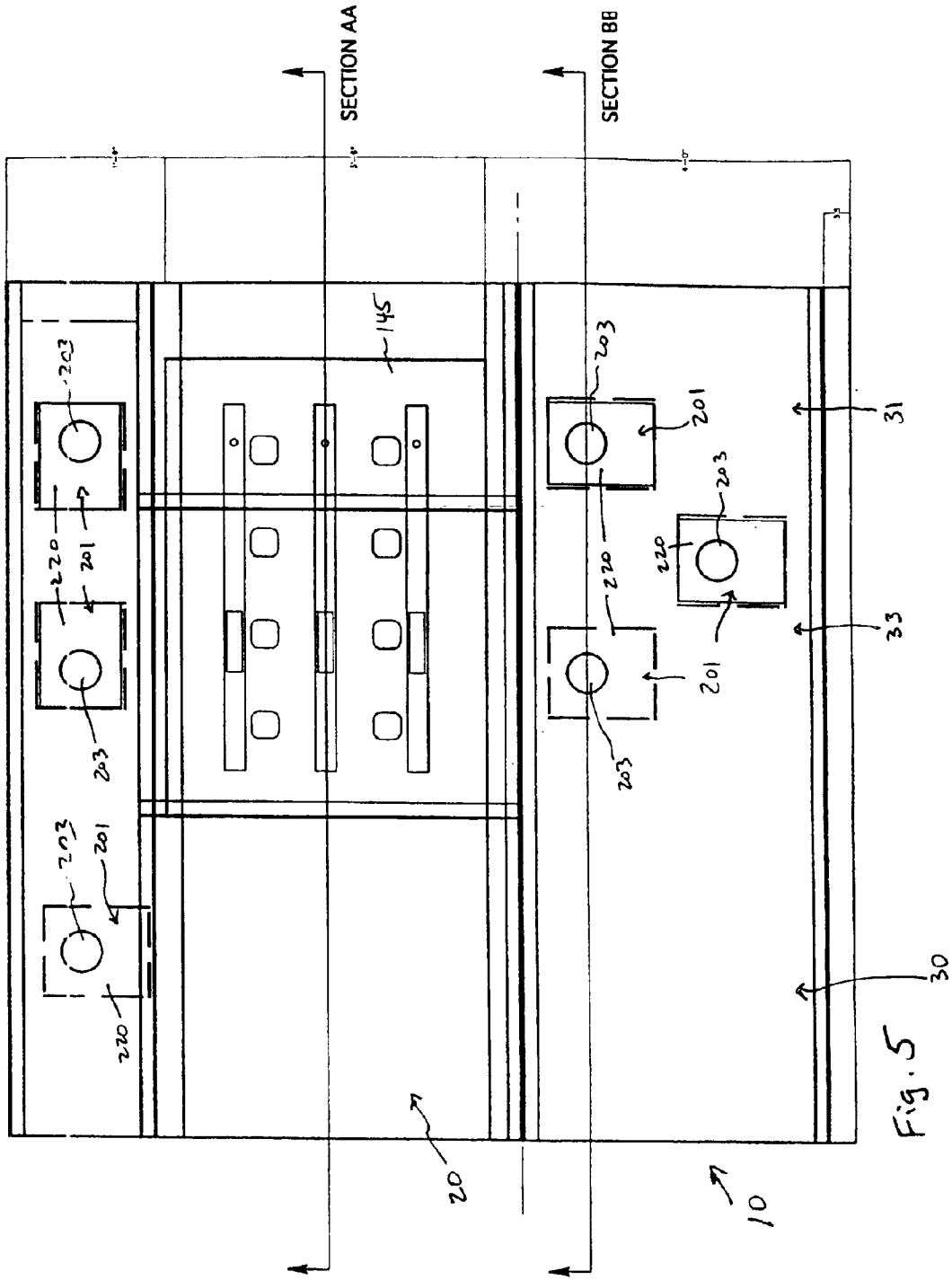

Fig. 5

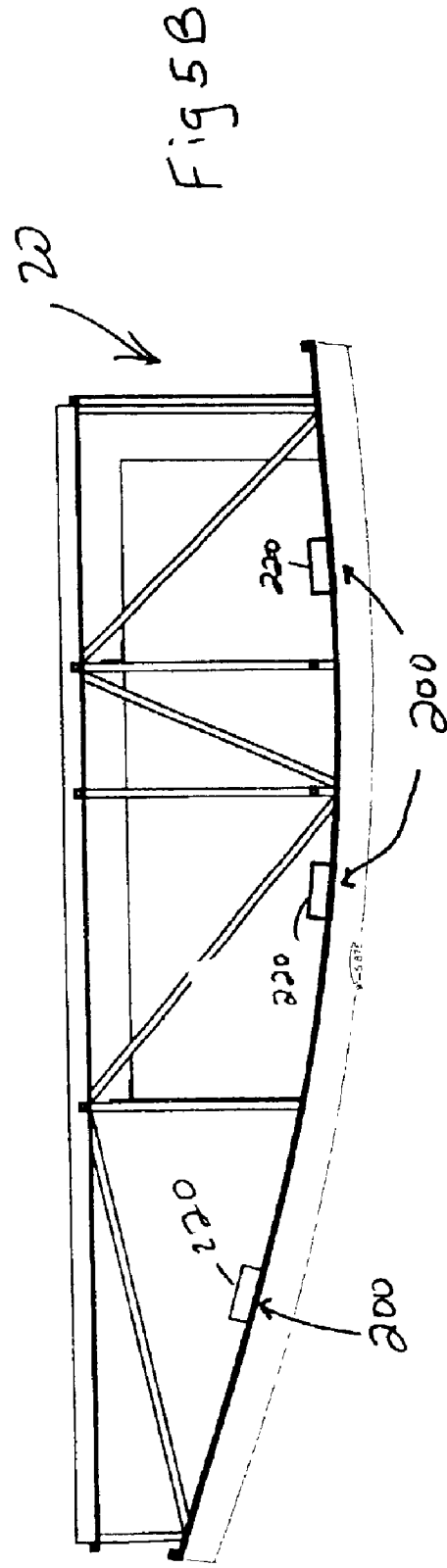
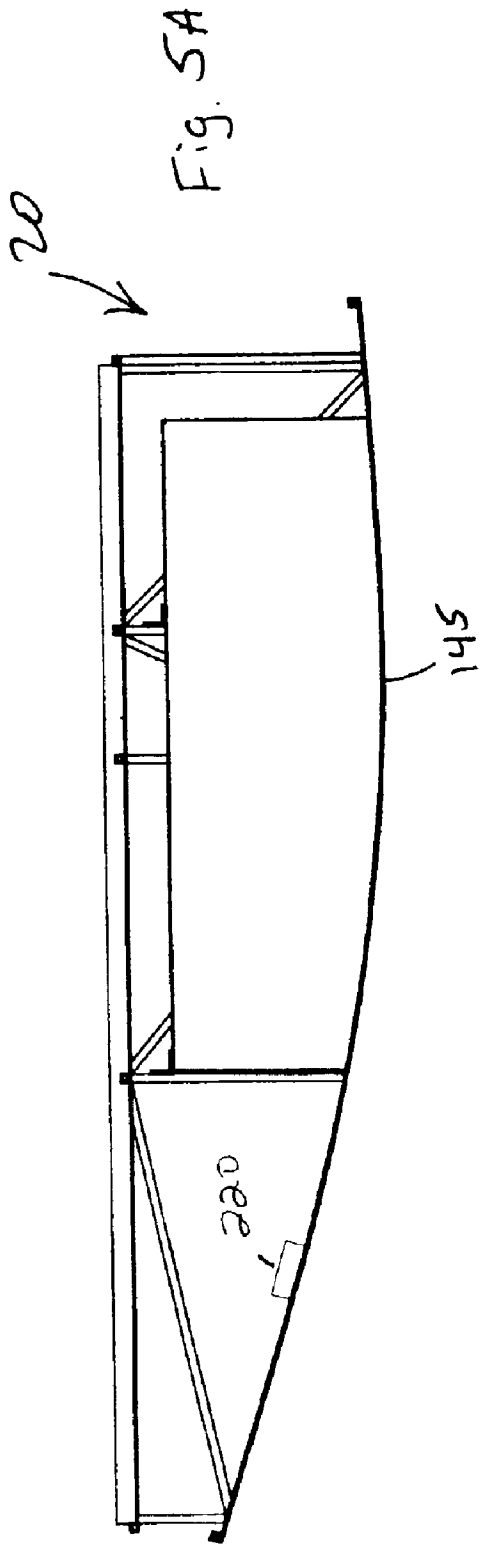
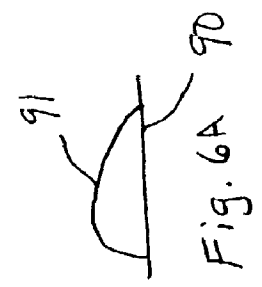
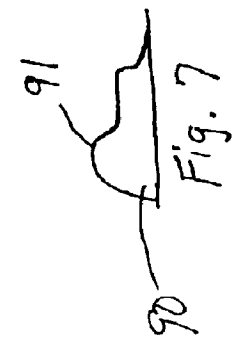
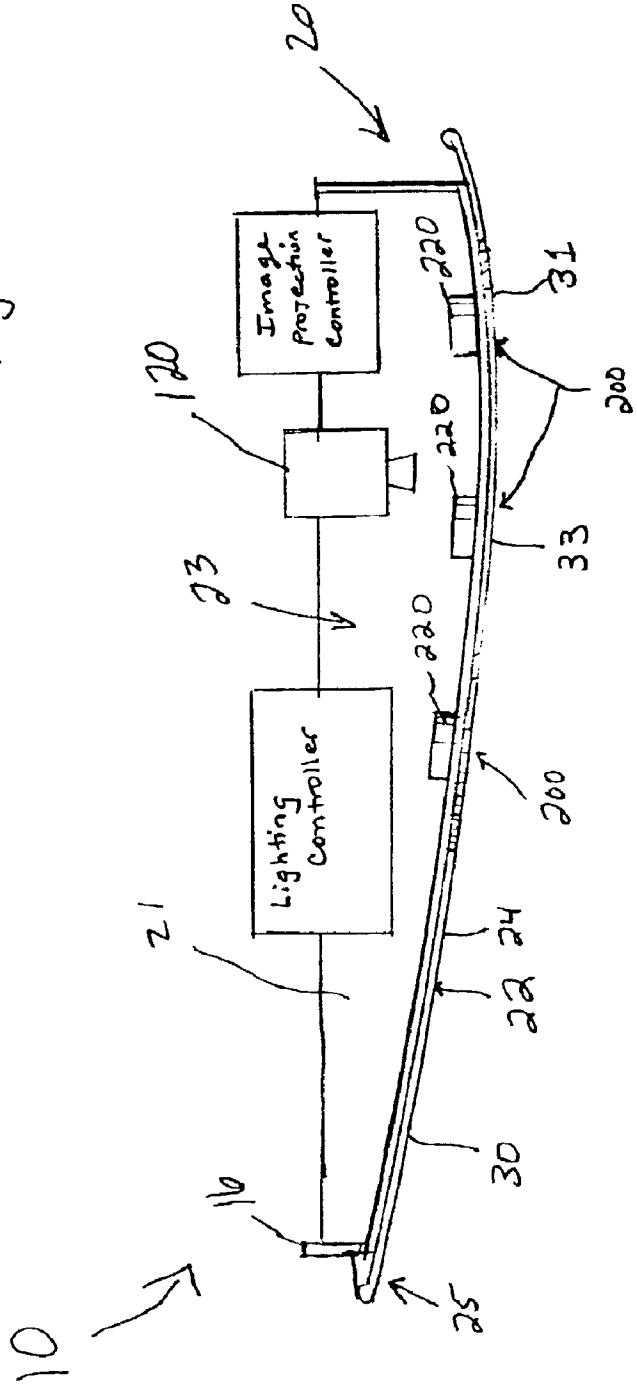

Fig. 5C



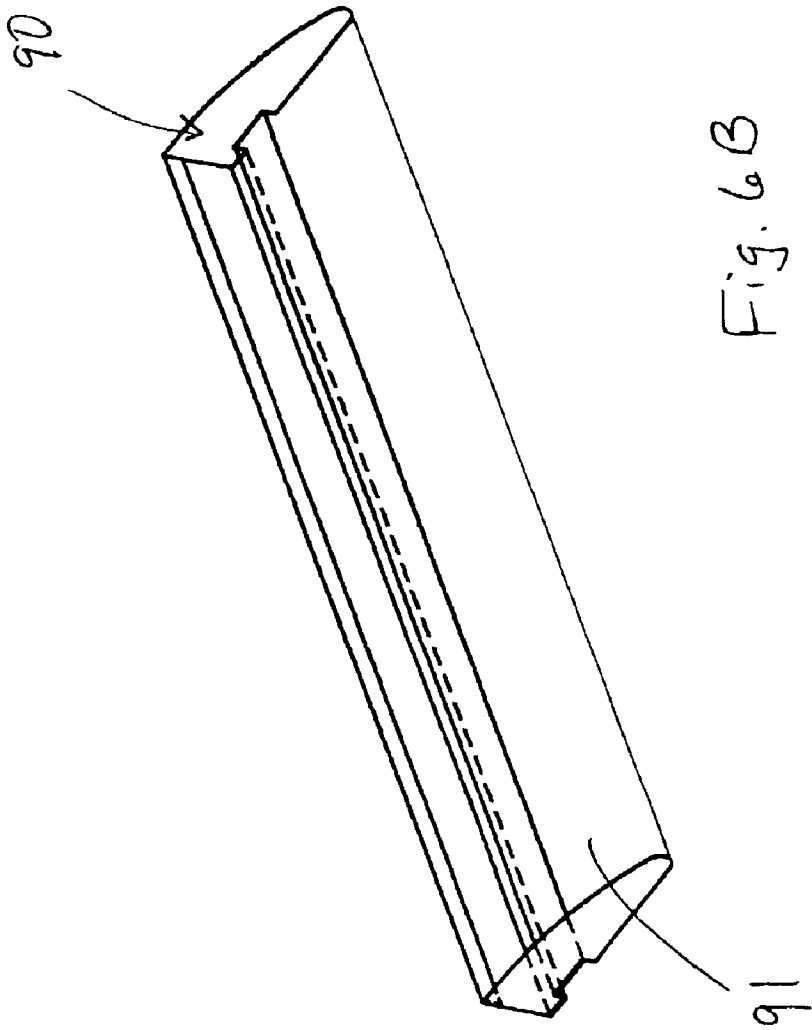
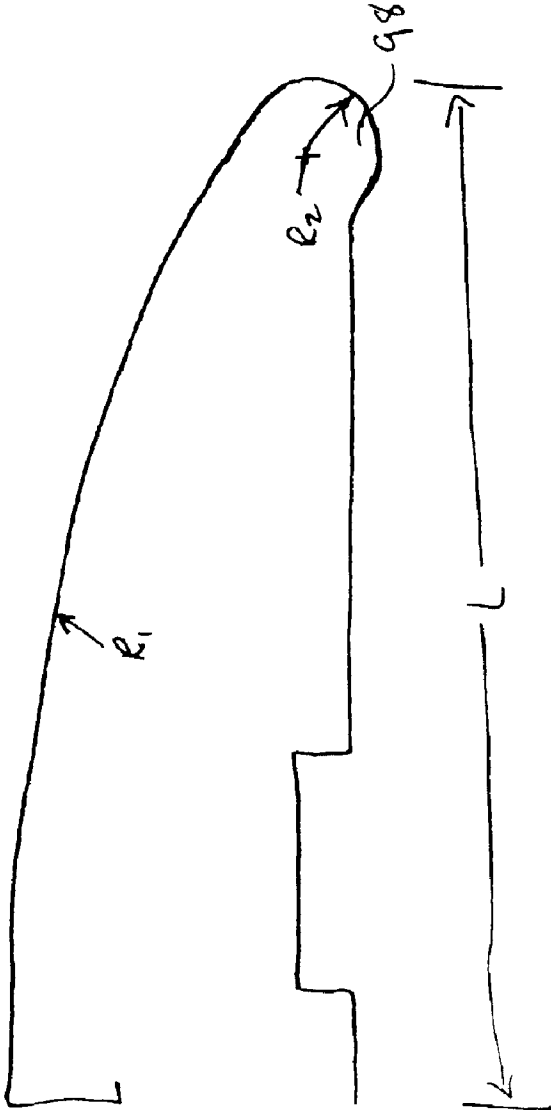
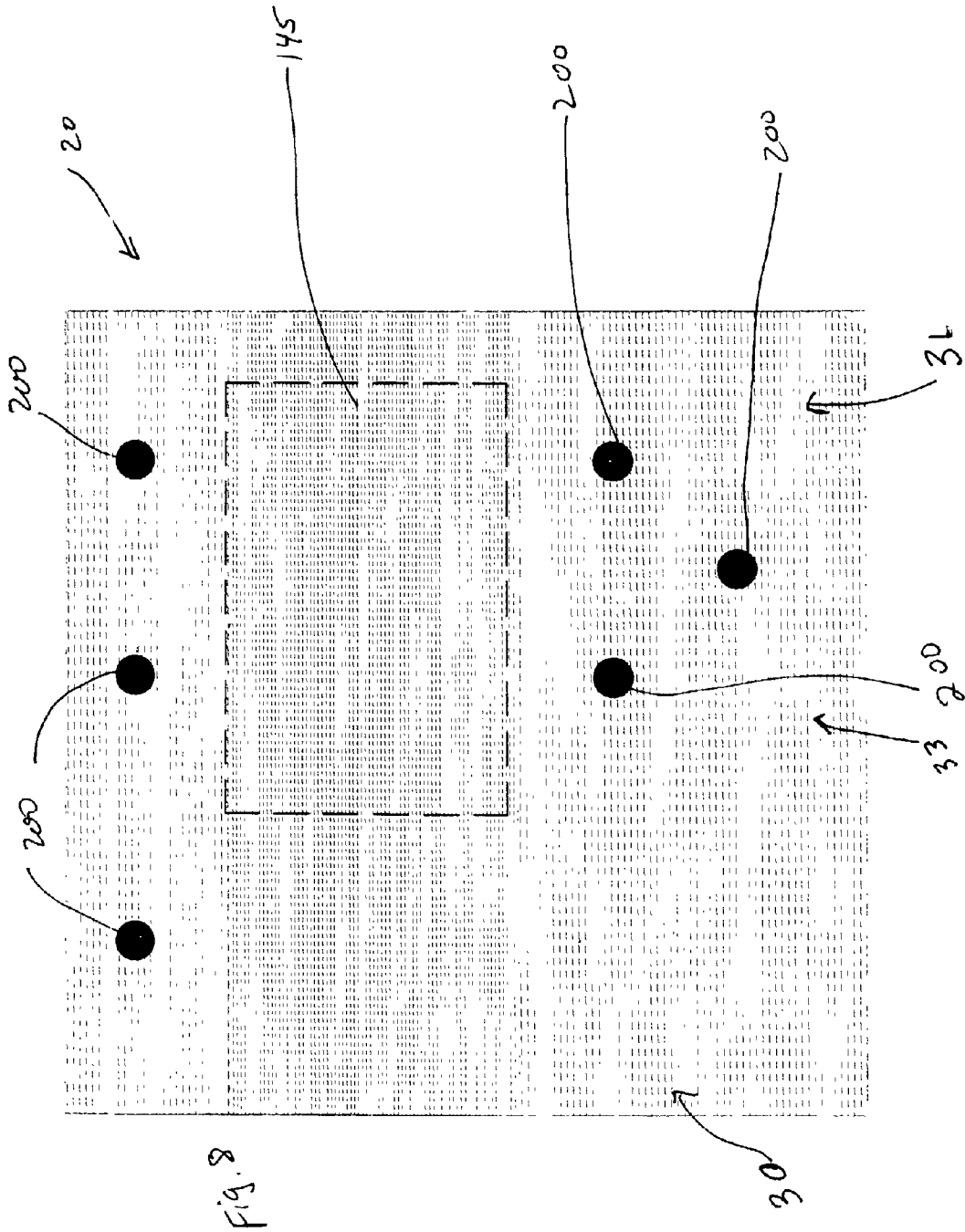

Fig. 6B

Fig. 6C





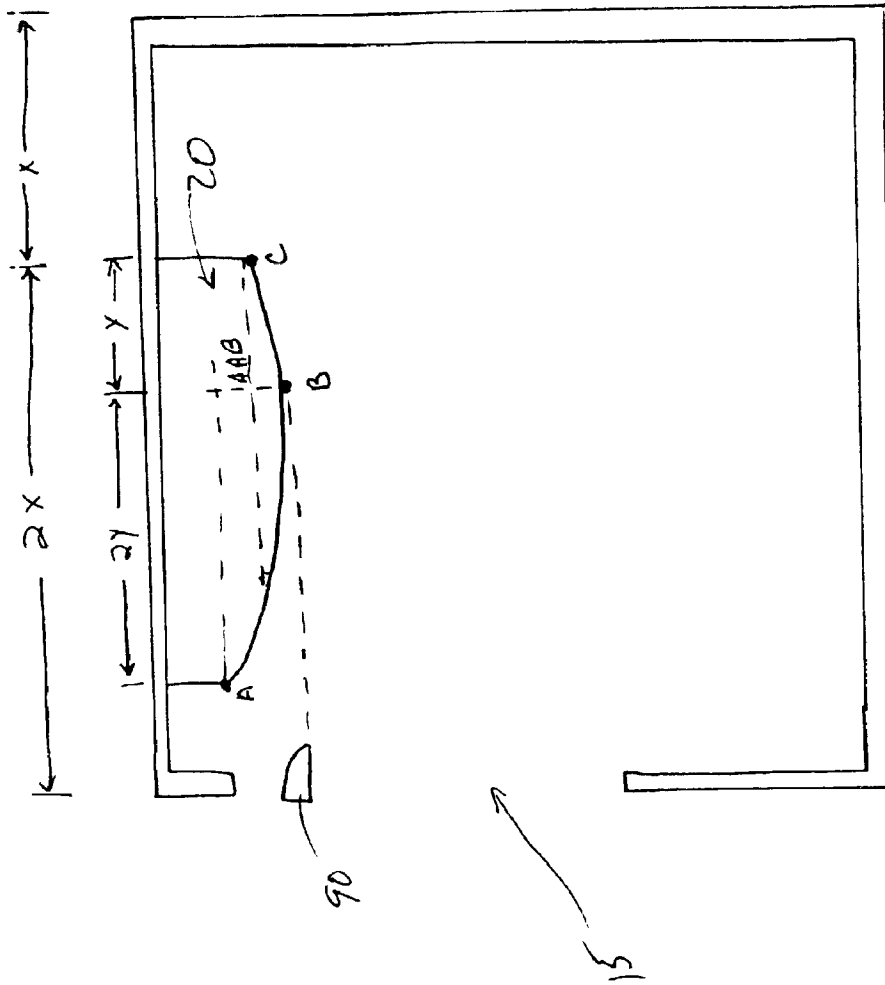

Fig. 9

1

**METHOD AND OVERHEAD SYSTEM FOR
PERFORMING A PLURALITY OF
THERAPEUTIC FUNCTIONS WITHIN A
ROOM**

**CROSS-REFERENCES TO RELATED
APPLICATIONS**

This application claims benefit of U.S. Provisional Patent Application No. 60/299,746, filed on Jun. 22, 2001, under 37 CFR 1.78(a). The full disclosure of this provisional application is incorporated herein by reference.

BACKGROUND OF THE INVENTION

The present invention relates to an overhead system for performing a plurality of lighting and imaging functions within a room for the comfort, enjoyment and non-drug therapy of an occupant. More specifically, the present invention relates to an overhead canopy that cooperates with imaging and lighting systems to display images on a canopy screen, provide predetermined task lighting and diffuse ambient and artificial light deep within the room.

Health conditions force many people to spend extended periods of time in hospitals or other health care facilities. This is especially true for people who have long-term illnesses or terminal conditions. Despite the many things that hospitals have and do to make their patients comfortable, an extended stay in any hospital can be very difficult and frustrating for the patient. Staying in a hospital room and staring at the same pictures or a television over a long period of time can cause a patient to become bored, depressed and even upset. As is well known in the health care industry, an upset or irritated patient can easily turn into a bad patient. Such patients can be difficult for the hospital staff to work with and treat. Additionally, the negative mental health of these patients may hinder their own recovery.

Patients may also experience severe depression and/or anxiety if they are forced to constantly stare at plain, sterile walls and ceilings. A patient could become frustrated and outwardly aggressive and/or abusive if she is constantly deprived of the ability to view sights or events that she is accustomed to seeing. For example, a patient may become depressed if she is not able to see the sun set or the wind blow through a grove of trees. Similarly, a patient who lives at the beach may begin to resent their condition, the facility he is in and its staff if he is unable to see the ocean waves crash upon a beach.

This is even true of pediatric patients. Children who are confined to hospital rooms for even a short period of time can easily become bored and depressed. In addition, a long term hospital stay can be very difficult and possibly traumatic for a child who is unable to see or communicate with one or more of his parents, siblings, other relatives, friends and pets for extended periods of time. This is especially true for children who are quarantined or otherwise isolated from visitors and the rest of the outside world. Unfortunately, an unhappy patient may not recover as quickly as a content patient.

In order to make patients feel more comfortable while they are in the hospital, some institutions permit their patients to bring personal belongings with them and position them about the room. These belongings can include pictures, posters, etc. However, the pictures and posters are typically placed in a designated area, such as a table that is positioned to the side of the bed or at a location along one of the walls within the room. Unfortunately, over time, these pictures can

2

be displaced because of medical procedures performed in the room. This can result in the picture being positioned too far away or in an impossible location for the patient to easily and clearly see it. Additionally, a patient may become bored with looking at the same picture for days on end. Similarly, the comforting effect of a single image/picture can diminish as the patient's stay continues. Therefore, even though a patient is able to bring at least one picture of secure and known environment or of familiar and comforting faces with him to a hospital, these pictures and posters may not prevent boredom and depression. Hence, at best, they have a diminishing, if any, beneficial effect on the patient's recovery.

In an attempt to overcome these problems, some prior art systems have tried to establish an environment within a hospital or convalescent room that would aid in the recovery of the patient. These systems provide a still picture, sound and odor. The sound and odor are related to the image on the picture. U.S. Pat. Nos. 5,676,633 and 5,681,259 to August each describe such a system for use in a health care facility or a home-based convalescent environment. Both patents to August disclose a method and system for promoting patient relaxation, reducing patient stress and expediting patient recovery by exposing the patient to external stimuli. The stimuli can be visual, auditory and/or olfactory. The patient is provided with the option of choosing one or more still, natural landscape scenes to which the patient is believed to have an innate positive (biophilic) affinity. This scene is scanned into a computer and then transferred to a flexible, high resolution fabric that is attached to the hospital curtain at the foot end of the patient's bed or the ceiling. Alternatively, the still scene can be transferred directly to a portion of the hospital curtain. The still scene can be positioned on the curtain so that it will be visible to the patient when the screen is partially closed. In addition to the visual image, the patient can be provided with natural sounds corresponding to the depicted scene and/or mild aromatic odors which are reminiscent of natural odors found in the pictured scene. As discussed above, the patient may be bored by looking at the same image for hours on end. Also, the noise and odors produced in the system may disturb other patients in the ward or in a neighboring room. Moreover, the still pictures provided cannot be changed automatically, nor can they be changed quickly. This prevents the patient from looking at different images which could sequentially depict different tropical settings, natural wonders, family members, rooms in a home, etc.

In addition to making the patient comfortable, the hospital room must also allow doctors and nurses to examine the patient and perform certain procedures. This is true of all aspects of the room including the lighting system. The lighting system in a hospital room can be critical. It must provide light for generally illuminating the room during normal times. The lighting system must also provide focused light when an examination or other medical procedure is being performed.

If the room has a window, both natural light and artificial light are available sources for illuminating the room. It is well known that natural light can aid in a patient's recovery by stimulating the production vitamin D and by maintaining or restoring the balance of the patient's circadian rhythm. However, when the sun is not facing the window, natural light rarely travels deep into the room in a direction away from the window and over the patient's bed. Also, depending on the size of the room, natural light may not travel deep into the room when the sun is facing the hospital room window. As a consequence, artificial light sources must be

turned on during the day to brighten the deeper portions of certain hospital rooms. The need for artificial light during the day can aggravate or depress some patients.

Direct, natural lighting is normally not relied upon as the sole lighting source during patient examinations, drug applications or other medical tasks. Additionally, positioning the patient bed so that the natural light can be relied upon could cause the patient discomfort. For example, the sunlight could be too bright for the patient's eyes and/or too warm on the patient's body. As a result, diffusion shelves have been used to diffuse natural light as it enters a room. However, the prior art light diffusion systems do not diffuse the natural light deep enough into the room in a direction away from the windows to make them effective for completely illuminating the "dark corners" of a room—the corners furthest from the natural lighting sources (windows).

One known system for illuminating a room with diffused natural light is disclosed in German Patent No. 631,798. In this system, both natural light and artificial light are directed into a room. A reflective member is positioned along an opening for reflecting light entering the room through the opening off the ceiling. The light is then reflected off the ceiling and into the room. The depth of the diffusion into the room depends on the angle of inclination of the reflective member relative to the light source. Artificial light can also be directed at the ceiling and thereby reflected into the room. As with other prior art light diffusion systems, the entire ceiling should be painted with a very bright color that is capable of reflecting the light. Similarly, the ceiling should be substantially void of any appliances that will prevent light diffusion. Additionally, the ceiling is not shaped to force the light deep into the room in a direction away from the light source.

Additional prior art light diffusion systems are known. U.S. Pat. No. 5,293,305 to Koster discloses a light guidance system positioned along a window for illuminating the interior of a room. The light guidance system includes a light deflection device that reflects daylight coming in through the window and artificial light generated by an artificial light source located within the room. The light deflection device comprises several spaced reflectors that extend parallel to each other along the height of the window. The reflectors guide the light from the natural and artificial light sources to the room ceiling and into the room for illumination. As with other prior art illuminating systems, the system of Koster relies on the flat ceiling to direct the light into the room. Effective light diffusion cannot occur by bouncing the light of a flat ceiling because the shape of the ceiling is not capable of providing the light deep into the dark corners of the room.

The unfriendly appearance of a hospital room ceiling can also be a source of problems and frustration for a patient. For many patients, staring at a blank ceiling for an extended period of time can be another source of boredom and depression that makes them anxious and irritable. This is particularly true at night when a patient is forced to stare at ceiling having a dark, empty appearance. These problems are amplified for a pediatric patient.

Typically, young children are afraid of the dark. Therefore, a child staring into a dark, empty ceiling may become scared, begin to cry and attempt to leave his bed. While trying to escape from his bed, the child may hurt himself while tearing at any restraints holding him in the bed or any medical devices connected to his body. Such a situation can be very dangerous for a child who is connected to an intravenous fluid source. Similarly, if the child begins

to cry or scream, it can be very upsetting to the other patients on the floor. Additionally, this situation can be difficult for the hospital staff because calming and comforting the child causes them additional work.

The need exists for a system that can provide different, automatically changeable images to an overhead image screen for entertaining, calming and comforting a patient so that conditions that can adversely affect the healing process, including boredom and depression, do not occur. Also, the need exists for such an overhead system that includes an artificial lighting system that provides predetermined lighting schemes within the room. Further, such a system that can effectively diffuse natural and/or artificial light deep within a room is also needed.

SUMMARY OF THE INVENTION

The present invention relates to a system that provides biosynchronized therapy to a user. Biosynchronized therapy provides a patient with a therapeutic environment and therapeutic stimulations that are sensitive to psychological and sensory human issues, including those particular to the patient, and that reduces psychological stress experienced by the patient so that other forms of treatment provided to the patient are enhanced and benefited. In one embodiment, the environment and stimulations can be predetermined. The provided benefits can include a reduction in the duration or repetition of a particular therapy, be it physical or drug based. Evidence-based mind-body research demonstrates that the psychological state (anxiety, stress) of a patient directly affects their physiological condition. These affects influence the time and effectiveness of the patient's recovery. More specifically, they influence recovery from illness, surgery or other trauma. The fields of psychoneuroimmunology and psychoneuroendocrinology have shown that body chemistry is directly influenced by numerous environmental stress conditions and stimulations. The realization that lymphoid and immune tissues are nerved, and that they contain receptors to neuropeptides whose sensitivity can be altered by hormone levels and cycles that can be controlled by the brain, along with the parallel realization that immune cells produce cytokines, steroids and peptides that influence specific and global regions of the brain has forever changed our perception of the unity of mind and body. (*IND-BODY MEDICINE: Clinician's Guide to Psychoneuroimmunology*; Churchill Livingstone; Dr. Alan Watkins; 1997) As a result, biosynchronized therapy takes advantage of the body's natural responses and enhances the effects of the therapy provided to the patient. For example, it can control the synchronizing of particular glands and the natural circadian rhythm of the body.

The invention relates to an overhead system including a suspended canopy for use in a room, such as a hospital room, for performing multiple functions. The overhead system includes a lighting system and a canopy for providing natural ambient light, artificial ambient light and predetermined task lighting within the room. An image display system is also included for applying preselected images to the canopy over the bed of a person. The overhead system can be used in a variety of circumstances such as a home, commercial facilities and health care facilities. For example, the overhead system can be used in a pediatric hospital room to provide soft, comfortable lighting and pleasant, recognizable images for a child who is in the hospital for an extended period of time.

The system for comforting a person within a room according to one embodiment of the present invention comprises a

5

canopy structure that extends away from a ceiling and above the person. The canopy structure has a lower outer surface that faces the room floor. The lower outer surface includes at least one light diffusion section that is shaped to diffuse light away from the canopy structure and into the room. The system also includes a lighting system that has at least one lighting source positioned within the canopy structure. The at least one lighting source is capable of projecting light in a direction away from the canopy structure for illuminating a room. An image projection screen extends along a portion of the canopy structure and receives images from an image source. The image projection screen is capable of displaying an image so that it can be viewed by the person.

In another preferred embodiment, the present invention comprises an overhead structure that extends away from a ceiling within a room. The structure includes a canopy that has a lower surface. At least a portion of the lower surface is curved so that it diffuses light from a lighting source deep into the room. An image projection screen extends along a portion of the lower surface of the canopy for displaying images received from an image projection system.

A third embodiment of the present invention includes an overhead image display structure that extends away from a ceiling of a room. The structure includes a canopy that has a curved lower surface that diffuses light into the room. The curved lower surface includes an image display screen for receiving and displaying a plurality of images provided by an image source, and a plurality of light emitting sources positioned for providing predetermined task lighting within the room. The predetermined task lighting permits a health care professional to only illuminate the portions of the patient's room that needs to be illuminated to perform a predetermined function. This prevents the patient or other people within the room from experiencing discomfort when the lights are turned on because only the lights needed to perform a function will be illuminated. This prevents overhead lights from shining in someone's eyes when the patient's legs or other parts of the body below the neck are being examined.

The images provided on the image screen can be calming to the patient and possibly stimulate his healing process. These images can be stills (individual images) or moving pictures (dynamic and continuous—like a movie). When still images are used, the image can also be automatically changed so that the person viewing them does not become bored, depressed or irritable. The images also provide the person with the opportunity to view people, pets or locations that are very important to him and that provide him great comfort or motivation for recovering quickly.

BRIEF DESCRIPTION OF THE FIGURES

FIG. 1 is a side, perspective view of an overhead system according to the present invention with natural light being diffused deep into a room by a light diffusion member and the canopy;

FIG. 2 is a side, perspective view of the overhead system according to the present invention with artificial light being diffused deep into a room by a light diffusion member and the canopy;

FIG. 3 is a side perspective view of the overhead system according to the present invention displaying an image on the image display screen;

FIG. 4 is a side perspective view of another embodiment of the overhead system according to the present invention;

FIG. 5 is a schematic plan view of the canopy with the covering material removed;

6

FIG. 5A is a cross section of the canopy taken along the section line AA of FIG. 5;

FIG. 5B is a cross section view of the canopy taken along the section line BB of FIG. 5;

FIG. 5C is a schematic cross section of the canopy according to the present invention;

FIG. 6A is a cross section of a light diffusion member according to the present invention;

FIG. 6B is a perspective schematic view of the light diffusion member with a lower attachment groove illustrated in broken lines;

FIG. 6C is a side view of the light diffusion member shown in FIG. 6B;

FIG. 7 is a cross section of the light diffusion member according to an alternative embodiment of the present invention;

FIG. 8 is a plan view of the canopy having an alternative light source arrangement compared to that shown in FIG. 1; and

FIG. 9 is a schematic view of the canopy extending from a ceiling and a cooperating light diffusion member.

DETAILED DESCRIPTION OF THE INVENTION

As shown in FIG. 1, the present invention includes an overhead system **10** that is suspended from a ceiling **1** within a room. The overhead system **10** is used to provide therapy to a health care patient by facilitating practitioners working with known evidence-based mind-body therapy protocols, such as visualization, guided imagery or feedback. While the overhead system **10** will be described for use within a pediatric hospital room, its application is not limited to such. Instead, it can be used within any room in a hospital, convalescent home, nursing home, doctor's office, dentist's office or other health care facilities. Additionally, while not as preferred as using the overhead system **10** in a health care facility, the invention can be used outside of the health care facility, and possibly outside of the health care industry. For example, the overhead system **10** could be installed in the home of a patient who is unable to move or be moved for an extended period of time.

The overhead system **10** performs numerous functions, as discussed below. These functions include diffusing natural and artificial light deep within a room, displaying comforting, relaxing images for a viewer such as a patient and providing predetermined task lighting schemes. The overhead system **10** includes an overhead canopy **20**, an image projection and display system **100** and a task lighting system **200**. The overhead system **10** can also include a light diffusion member **90** that cooperates with the canopy **20** to diffuse natural and artificial light deep into the room in a direction away from windows **15** or artificial light source(s) **16**.

The phrase "deep into the room" refers to light being diffused in a direction away from the windows **15**, across the interior of the room and to locations proximate the side of the room opposite the windows **15** such as near or along the wall opposite the windows. Other locations that are "deep in the room" include the far or "dark" corners of the room that are away from the windows.

FIGS. 1 and 2 illustrate the diffusion member **90** positioned along a source of natural light such as the windows **15** and a source of artificial light such as lamp(s) **16**. As shown in these figures, diffusion member **90** directs the natural light that enters through windows **15** and the arti-

cial light from source **16** inwardly and upwardly toward the canopy **20**. The arrows in the figures illustrate the path that the light takes as it leaves diffusion shelf **90** and is diffused by canopy **20** deep within the room.

As shown in FIGS. 6A–C, the diffusion member **90** is a light shelf having a convex, upper surface **91** that is curved in the direction of the interior of the room. Diffusion shelf **90** has a radius of curvature of between about 15 and 25 inches. In a preferred embodiment, the radius of curvature **R1** is between about 18 and 22 inches. A preferred radius of curvature is about 19.75 inches. However, the radius of curvature can change depending on the overall size and depth of the room. The length **L** (depth) that the diffusion shelf **90** extends into the room can be between about 10 and 11 inches. In a preferred embodiment, the length is about 10.83 inches. The innermost point of the shelf **90** includes a rounded portion **98** having a radius of curvature **R2** that is about 0.75 inch.

In an alternative embodiment shown in FIG. 7, the upper surface **91** has multiple curves for directing the natural light at the canopy no matter the position of the sun. Other well-known shapes that efficiently diffuse light into a room could also be used for surface **91**. For example, the upper surface **91** could be a flat, horizontal surface (shelf) that extends into the room. Alternatively, the upper surface **91** could extend downwardly into the room at a constant angle to the horizontal so that light can be diffused into the room. The angle could be between 1 and 30 degrees. In one embodiment, the angle of upper surface **91** is fifteen degrees relative to the horizontal.

The upper surface **91** of the diffusion shelf **90** is formed of the same rigid material as diffusion shelf **90**. Alternatively, this rigid material can be covered by a fabric or other material such as a light diffusing and reflective coating or applied film surface that is capable of diffusing light in the direction of the canopy **20**. Any coating or surface covering that provides at least fifty percent or higher surface reflectivity could be used. For example, a high gloss paint could be used. One such paint is sold by PPG Industries as ALK-200 L.I.C. paint, white variant 91096.

The overhead canopy **20** is secured to the ceiling **1** in a well-known manner. This includes securing the canopy **20** by screwing it into the ceiling **1** or bolting it to the ceiling **1** via brackets or other well-known securing members. Other well-known ways of securing a structure to a ceiling could also be used. When secured, the overhead canopy **20** is positioned so that it can diffuse light deep within the room and so that the patient can conveniently see the image screen **145**. For example, the canopy **20** could be positioned in the middle of the ceiling **1** or centered over the patient's bed. In a preferred embodiment, the canopy **20** is positioned with the image screen **145** centered over the patient's bed.

As shown in FIG. 1, the canopy **20** has vertical sidewalls **21** and a lower wall **22**. The inner surfaces of the sidewalls **21** and lower wall **22** form the interior **23** of the canopy **20**. As shown in FIG. 5, the interior **23** houses a plurality of the control mechanisms for the overhead system and parts of the image projection system. An endwall **25** of the canopy **20** that is proximate the windows **15** includes a mounting surface **26** for permitting artificial light from artificial light source(s) **16** to enter the room via diffusion shelf **90**. The endwall **25** is oriented so that it faces toward the diffusion shelf **90** proximate the windows **15**. This orientation permits light emitted from light source(s) **16** to contact diffuser **90** and be diffused in the direction of the lower wall **22** of canopy **20** and into the room. Alternatively, the mounting

surface **26** could be positioned in the direction of a light diffuser **90** that is located elsewhere in the room for directing the light from source(s) **16** immediately into the room and/or off the lower wall **22**.

The outer surface **24** of lower wall **22** faces into the room in order to diffuse light from both light sources **15**, **16** deep into the room. As shown in FIGS. 1, 2 and 5–5C, the lower wall **22** of the canopy is curved in a first direction along a first section **30** and in a second direction along a second section **31**. The curved sections **30**, **31** provide a continuously angled surface that diffuses light from sources **15**, **16** deep into the room as discussed below. The second, curved section **31** includes curved light diffusing areas **32** that surround an opening **140** in outer surface **24** for an image display screen **145**.

Light diffusion portions of sections **30** and **31** that are primarily responsible for diffusing light into the room are covered with a material that is capable of performing this diffusing function. The light diffusion material also prevents a “dark hole” effect from being created on the ceiling when the lights in the room are turned off. In a preferred embodiment, the light diffusing material can be a surface treated perforated polypropylene. However, other materials that are capable of diffusing light that is directed at the canopy **20** deep within the room without creating a “dark hole” ceiling could also be used. These other materials include lightweight, rigid materials covered with a composite material of PVC and fiberglass, such as Hunter Douglass Sheerweave® 2000 fabric.

As mentioned above and as shown in FIGS. 1, 2 and 5–5C, the sections **30** and **31** are not flat like a prior art ceiling. Instead, section **30** curves downward from opening **26** near the windows **15** to the section **31** that is positioned about the middle of the room and/or over the patient's bed. Contrary to section **30**, section **31** curves upwardly as it moves in a direction away from the windows **15** and section **30**. The continuous curves of both sections **30**, **31** provide a gradual, continuous change in the elevation of the lower wall **22** over its length. The section **30** of wall **22** has a radius of curvature of between about 15 and 23 feet. In a preferred embodiment, the radius of curvature is about 18 feet. The section **31** has a radius of curvature of between about 15 and 23 feet. In a preferred embodiment, the radius of curvature is about 18 feet. However, these radii of curvature will change as the size of the canopy **20** changes. The shape of the canopy **20** can change with the size of the exterior windows and the room depth and height. In one embodiment, the depth of the canopy is two-thirds the depth of the room as shown in FIG. 9. Therefore, the specific depth of the canopy into the room will change with the depth of the room. For example, the canopy **20** could be about six to seven feet long for a room that is ten feet deep, and twice that depth for a room that is twenty feet deep. It is also contemplated that sections **30** and **31** could be angled with a slight curve at their lower extremes.

As shown in the figures, especially FIG. 9, the curve between points A and B is about two-thirds of the canopy surface. Similarly, the curved surface between points B and C is about one-third of the canopy surface. Thus, point B is the lowest surface of the canopy and point A is the highest. This is clearly shown in the figures, especially FIGS. 5–5C and 9. Point A is typically at the same height within the room as the top of the windowsill. Point B is typically positioned so that it is no lower within the room than the leading edge of the light diffusion shelf **90**. In this embodiment, the diffusion shelf is located above eyelevel for the patient. In one embodiment, the diffusion shelf is located at least six

feet above the floor. Point C is positioned along the height of the canopy **20** at about the center point (half) of the vertical difference between point A and point B. As a result, point C is a function of the distance between points A and B. The circle circumscribing points A, B and C determines the radius of curvature for the canopy.

The continuous change in elevation caused by the slow, gradual slopes and opposing curves of sections **30** and **31** results in light being diffused deep into the room. These sections **30, 31** diffuse the light further into the room than a flat, conventional diffusion ceiling. The diffused light is illustrated in the figures by the depicted arrows. As shown in the figures, light can be directed to canopy **20** by the diffusion shelf **90** or it can come directly from a light source. It is not necessary to use diffusion shelf **90** for the canopy **20** of the present invention to operate properly. The slow slope of each section produces an infinite number of diffusion angles that combine with the infinite number of angles at which the light approaches the canopy **15** to cause the light from the sources **15, 16** to diffuse deep within the room. This is contrary to the prior art diffusion systems that rely on the angle of the light to dictate the direction of diffusion because the flat, planar ceilings can only diffuse light in one direction—perpendicular to the angle at which the light contacts the ceiling.

The sections **30, 31** of the canopy **20** provide an infinite number of diffusion angles. These angles cooperate with the angle of attack of the light emitted from the light source or diffusion shelf **90** to diffuse the light in multiple directions and deep within the room. When the light is diffused or otherwise directed at the curved sections **30, 31** or the transition area **33** between sections **30** and **31**, it will be diffused in as many directions as there are contact angles on these sections. For example, the larger angles (measured with respect to the horizontal) that are proximate the opening **26** cause the light to be diffused over the center of the room or the patient bed. The smaller angles of section **30** and transition area **33**, which are proximate section **30**, will diffuse the light deeper into the room than the larger angles. Similarly, the angles of section **31** which extend in an opposite direction to those of section **30** are capable of diffusing the light to the deepest corners of the room as shown in FIGS. **1** and **2**. Transition area **33** can include a flat surface that is substantially parallel to the image display screen **145** (when flat) and the floor of the room.

The image display screen **145** can be curved so that it follows the contour of lower wall **22** or it can be flat. The opening **140** is covered with a material that is different from that covering the other portions of lower wall **22**. This is because the screen **145** is intended to perform a different function. Instead, the main function of the screen **145** is to display projected images. The screen **145** is also intended to diffuse light when it is not displaying an image. Accordingly, the material that forms screen **145** is chosen for its ability to clearly display an image while also being able to diffuse light deep into a room. In a preferred embodiment, the screen **145** includes a translucent material covered by a vinyl covered cotton fabric, such as Hunter Douglas “PIMA”, a 100% cotton fabric with a vinyl coating. Like PIMA, the materials for the screen **145** are light filtering and fade and stain resistant materials. The materials used for the screen **145** can include a small weave pattern that does not affect the clarity of the projected image. Also, the translucent material and covering fabric cooperate to diffuse light and to prevent the canopy from appearing dark when an image is not being projected. In an alternative embodiment, the screen **145** of the preferred embodiment of the present

invention includes an array of pixels for presenting images that represent computer text and graphics, television signals or video feeds. Additionally, the screen **145** could be the same as the material used to cover sections **30, 31**. In this embodiment, the fabric would be stretched taught as a screen for use with an image projection system, such as a Kodak DP1100 Digital projector.

The present invention also includes an image projection system **100** for providing an image on the image display screen **145** of canopy **20**. The image is intended to make the patients feel more secure and comfortable so that they will remain in good spirits. As discussed above, a happy patient can recover quicker and be less of a drain on the hospital staff. Additionally, comfortable and occupied pediatric patients are less likely to injure themselves by trying to escape restraints or remove needles in order to escape their beds.

Although this specification may refer to the invention or components of the invention as relating to “video,” “screens,” “projected” images, etc., any manner of displaying images onto a screen or surface is adaptable for use with the invention. Specifically, although the invention is referred to as an “image projection system” or an “image source”, this term is intended to indicate that either still or moving images are displayed by projection or direct display. This phrase does not limit the invention to projected slides, video or video related display mechanisms. Further, any type of images may be displayed on the screen(s) of the present invention including still images (i.e., “slides”), arbitrary light patterns as from prism refraction, color filters, shadowing, etc. In addition, the images could be stored analog or digital images from a stored file such as a video tape, a DVD or other well known source that store multiple images such as movies. A digital camera providing a recorded or live feed could also be used as the image source.

In a preferred embodiment, the images can include transparencies, still photographs, multiple stored images on a roll or conventional slides of anything that is pleasant or comforting to the patient, such as his/her relatives, the sky with different cloud formations, trees, flowers, etc. In one such embodiment, backlit photographic transparencies are used to apply an image to the image display portion (screen **145**) of the canopy. The transparencies can be either a single image or multiple images on a roll. An electronic crank is used to change the images. This backlit system uses a white light box with a diffusion panel to evenly spread the light across the image display portion of the canopy. Alternatively, as shown in FIG. **5**, the projector **120** is used to project an image onto screen **145**. Projector **120** can project the image directly onto the rear, inside surface of screen **145** or via a mirror. Alternatively, projector **120** can be mounted along the wall of the room outside of the canopy for projecting images directly onto the front of screen **145**.

Another preferred embodiment for applying images to the image screen **145** employs rear projection technology currently used with televisions. The rear screen projection system includes a wide angle lens for projecting a received image onto the screen **145**. When the screen is curved, the lens is ground in a predetermined manner so that the projected image will be evenly applied across the curved, translucent image screen **145**. In an alternative embodiment, a plurality of lenses could be used as a system to provide single or multiple imaging effects.

In any of the disclosed embodiments or variations thereof, the image(s) can be provided by an analog or a digital signal source. Since the images are intended to have a therapeutic

value to the patient, the person in charge of the therapy or protocol in which the patient is involved selects them. Alternatively, the patient may be involved in selecting or directing the selection of the subject content for the images. However, the patient may not be able to communicate, whether verbally, or in an assisted manner, a directed personal choice. In these instances, the practitioner will be provided with numerous sets of still images, dynamic images (videos) and/or real time dynamic live video input material. The practitioner, nurse or other care provider may select subject material that suitable for conveyance of natural image settings that are appropriate for the patient's mental and physical condition.

The dynamic and real time images include digital or analog videos of friends and family members talking to the patient. They can also include videos of specific scenic areas or natural events that are of interest to the patient. For example, if the patient loves to climb mountains, the video may be the view of a pilot as he flies through a mountain range. Alternatively, the images could be individual digital photographs of different people or different locations.

No matter the type of image being provided, the system for controlling the image application to the screen **145** is well known in either or both the computer and television arts. For example, an APPLE laptop G3 computer with software such as JPEGView or MICROSOFT POWERPOINT can be used to deliver a sequence of images to the screen **145** for viewing by the patient. Alternatively, QUICKTIME could be used for providing digitally stored audio and/or video and for delivering streaming video and/or audio from the Internet. When a computer is not used to control the application of the images, video and/or audio, conventional audio-visual equipment could be utilized. This equipment can include a SONY SLV-N51 VHS player and/or a SONY DVD-s560D DVD player with a YAMAHA HTR-5240 receiver/amplifier. Any known speaker could be used with this system. One such speaker includes an ENERGY e:XL™ 15.

It is conceivable that video screens can be used in place of the image projection screen **145**. In this case, the display screen would itself be an entire video monitor such as a cathode ray tube (CRT) or other types of known picture tubes. Also, new types of display devices, for example, flat panel display technology including color liquid crystal displays or plasma screens such as Plasmatron RTM. by Sony Corporation, can also be used to display the comforting and relaxing images discussed above. In this embodiment, conventional digital projection technology is used to apply images to a plasma portion (screen **145**) of the curved canopy **20**. The digital image can be delivered from the image source, such as a computer, to the projection system using fiber optic cables or digital coaxial cables.

In another embodiment, the image can be a real time image received from a live feed. In this alternative embodiment, the images are received from a remote camera positioned at a location that is desired by the patient. The feed from this camera is projected onto screen **145** in real time by the system **100**. The projection system **100** receives the live feed and projects it onto the screen **145** as is well known in the television production industry or by using the Internet and a rear projector **120**. This embodiment permits the patient to see images from locations that they are familiar with and not able to visit. For example, a child could look in on his classroom at school or see his siblings and his dog moving around his house. This embodiment also allows a hospitalized mother or father to look in on the children at home that are not able to visit him/her in the hospital. In

either instance, the projection system delivers real time images to the image screen **145** that will entertain, comfort and bring happiness to the patient confined to the hospital room.

The curved or flat image display screen **145** is shown in the figures as being positioned substantially horizontal or otherwise substantially parallel to the floor of the room. In a preferred embodiment, the image screen **145** is perpendicular to a viewer's line of sight as the viewer looks upward from the bed. This position is very convenient for patients forced to lie on their back. Also, when still images of the sky are shown, the overhead position showing an image of the sky can appear to be a skylight. However, in an alternative embodiment, the screen can be positioned at an angle to the horizontal. Any advantageous position which is suitable for projecting images onto the screen(s) in a rear-projection or other known type of projection system could be used. Additionally, a system that displays images at different screen angles to the viewer's line of sight can produce interesting visual effects. In an alternative embodiment, the screen **145** could be oriented so that it is parallel to the patient's line of sight and at an angle to the horizontal when the head of the bed has been raised. Well-known ways of mounting the screen for movement could be used. These include hydraulic systems and screw-thread system that can be controlled by any well-known control system so that the screen will move with the patient as the patient moves.

As discussed above, canopy **20** also includes a task lighting system **200**. This lighting system **200** includes a plurality of lamps **201** that are secured within socket housings **220** in canopy **20**. The lighting system **200** provides different lighting schemes within the room for performing different tasks, such as patient examination and general illumination. Each lamp **201** is controlled to cooperate with one or more of the other lamps **201** to provide specific, predetermined task lighting and ambient/general lighting within the room. This is true for all the lamps **201** except for the individual lamp that is closest to the patient's chart. This lamp can be individually operated without the other lamps **201**. As a result, the chart can be read at 3:00 AM without the entire room being illuminated and the sleeping patient being disturbed.

In a preferred embodiment, the lamps **201** are well known incandescent lamps that are secured in the socket housings **220** and positioned at predetermined locations within the canopy **20** so that they can provide the desired task lighting schemes. In an alternative embodiment, the lamps **201** include halogen sources **205**, such as MR-16 lamps, positioned within the canopy **20**. No matter the type of bulb, the lamps **201** of lighting system **200** are arranged so that different tasks can be accomplished by illuminating only some of the lamps **201**. For example, one or more of the lamps **201** can be operated independent of the other lamps **201** to provide reading light at the head of the bed. Also, one or more lamps **201** can be used as a night light or an emergency medical lighting system. As shown in FIG. 2, the lamps **201** that are also designated as **202** are focused on the patient's bed and create an examination lighting scheme within the room. These lamps **202** illuminate the patient so that a doctor or nurse can perform a necessary examination without having to turn on all of the lights (lamps **201**) within the room. All of the above-discussed lamps **201** can be connected to a programmable lighting control system that allows the lamps **201** to be automatically dimmed or illuminated.

These lamps **201** include focusing lenses **203** that are flush with the outer surface of the canopy for changing the

13

diffusion of their emitted light. These lenses **203** can be manually or automatically adjusted to make the emitted column of light broader or, alternatively, narrower and sharper.

A computer including a microprocessor controls the operation of the individual lamps **201**. The microprocessor operates a prescribed program for accomplishing one or more predetermined lighting sequences in response to a specific input. The programmed sequence(s) can be automatically and manually stopped. An appropriate input includes depressing a button or otherwise activating a switch associated with the desired lighting task. An alternative input includes typing the code for a predetermined lighting scheme into a keypad in order to activate the scheme. For example, when a code relating to the examination lighting scheme is keyed into a number pad, the microprocessor initiates a predetermined lighting sequence. The examination lighting sequence can include the sequential illumination of some or all of the lamps **201**. Alternatively, the lighting scheme could include the simultaneous illumination of one or more of the lamps **201**. For example, when the code for the examination lighting scheme is inputted, the simultaneous illumination of the head, mid section and foot of the patient's bed by three lamp sets of lamps **202** could occur. Each lamp **202** may form a portion of more than one of the lamp sets. In this instance, if the light is moved down the bed and away from the patient's head, certain lamps **202** will remain illuminated, certain lamps **202** may become illuminated and certain lamps **202** will be turned off. Alternatively, each lamp **202** may only be assigned to a single set of lamps within the lighting scheme.

The microprocessor can also automatically change between different lighting schemes without being prompted. For example, the microprocessor can automatically change between the examination illumination scheme, a general ambient illumination scheme, a therapy illumination scheme, an emergency illumination scheme, a pre-dawn/pre-sunrise illumination scheme and a nighttime/sleep illumination scheme. Alternatively, these changes can be performed manually. In the automatically changing embodiment, the transition between the tasks would be preprogrammed so that the person working with the patient would not have to push a button, throw a switch or input a code each time she completes a task or wants to begin a new task. Instead, a predetermined amount of time would be allotted for the completion of each task. At the end of each time period, the lighting would be automatically cycled to the next task and the appropriate lamps **201** illuminated. Of course, a manual or remote control switch could be provided for overriding the program and allowing the attendant to manually control the lighting scheme. For an example, the general ambient lighting scheme may be timed for 3 hours and then the nighttime/sleeping scheme would be set for 8 hours. The manual override would permit the attendant to interrupt the nighttime/sleeping scheme if activation of the examination lighting scheme is necessary. One such controller that can be used to perform the above discussed lighting schemes includes those of the Lutron GRAFIK Eye 3000 series available from LUTRON® Electronics Inc. However, other well known light controllers could also be used so that the different lighting schemes are automatically or manually provided in the room at different times of the day and night.

As shown in FIG. 4, another embodiment of the lighting system **200** uses rows of fiber optic cables **255** secured within very narrow slots **250** in the canopy **20**. These rows **250** of fiber optic lights **260** include multiple oculars covered by a fabric. Each fiber optic cable **255** provides point

14

source lighting that is diffused by the covering fabric to wash the room with light without causing patient discomfort.

The lighting system **200** also includes the artificial light source(s) **16** provided to supplement the natural light source when a sufficient amount of natural light is not available. For instance, the light source **16** could be used at dusk or at night to indirectly light the room. Light source(s) **16** include incandescent or florescent lamps positioned within canopy **20** so that the emitted light will diffuse off surface **91** in the direction of canopy **20**. The exact position of the light source(s) **16** will depend on where the light is intended to contact canopy **20**. For example, the light sources **16** may be positioned along the surface of the canopy **20** closest to the windows.

While the above description contains many specifics, these should not be construed as limitations on the scope of the invention, but rather as an exemplification of one preferred embodiment thereof. Other variations are possible. Accordingly, the scope of the present invention should be determined not by the embodiments illustrated above, but by the appended claims and their legal equivalents.

We claim:

1. A system for comforting a person within a room, said system comprising:

a canopy structure for extending away from a ceiling and above the person, said canopy structure having a lower outer surface for facing a room floor, said lower outer surface including first and second light diffusing sections shaped to diffuse light away from said canopy structure and into the room, said at least one of said light diffusion sections of said lower outer surface being curved upward from a location spaced inwardly from a boundary of said lower outer surface to a first end of said canopy structure said first light diffusing section having a first end at said first end of said canopy structure for being spaced a first distance from the ceiling, said second light diffusing section having a portion for being spaced a second distance from the ceiling, said second distance being greater than said first distance, and said second light diffusing section being curved upwardly away from the image display screen to a second end of the canopy structure;

a lighting system including at least one lighting source is positioned within said canopy structure, said at least one lighting source being capable of projecting light in a direction away from said canopy structure for illuminating a room;

an image display screen extending along a portion of said canopy structure; and

an image source for providing images on said image display screen so that the images can be viewed by the person.

2. The system according to claim 1 further comprising a light diffusion shelf proximate a light source spaced from the lower outer surface of the canopy structure.

3. The light system according to claim 2 wherein said light diffusion shelf includes a light reflective covering.

4. The light system according to claim 3 wherein said light reflective coating includes a reflective paint.

5. The system according to claim 2 wherein said light source includes an artificial light source positioned proximate the canopy structure.

6. The system according to claim 5 wherein said artificial light source includes at least one light source positioned proximate an end of the canopy structure proximate said light diffusion shelf.

15

7. The system according to claim 1 wherein said second light diffusing section extends substantially parallel to the image display screen between a position along the length of the canopy structure and a second end of the canopy structure.

8. The system according to claim 1 further including a light diffusing area that extends between said first and second light diffusing sections, said light diffusing area extending substantially parallel to the image display screen.

9. The system according to claim 1 wherein said at least one lighting source comprises a plurality of spaced light sources located within said canopy structure.

10. The system according to claim 9 wherein said lighting sources include a plurality of lamps positioned along the lower outer surface of the canopy.

11. The system according to claim 10 wherein said lamps each include a focusing lens.

12. The system according to claim 9 wherein said at least one lighting source includes at least one row of a fiber optic cable.

13. The system according to claim 12 wherein said at least one lighting source includes a plurality of fiber optic cables secured within said canopy structure.

14. The system according to claim 1 wherein said image display screen includes an outer surface covered by a material which permits an image from the image source to be displayed.

15. The system according to claim 14 wherein said material includes a coated fabric.

16. The system according to claim 1 wherein said image source includes a system for projecting images on the image display screen.

17. The system according to claim 16 wherein said system for projecting images includes a rear projection system that is mounted within said canopy structure.

18. The system according to claim 16 wherein said system for projecting images includes a projector for displaying still images on said image display screen.

19. The system according to claim 18 wherein said projector is located within the canopy structure.

20. The system according to claim 18 wherein said projector is located outside of said canopy structure.

21. The system according to claim 16 wherein said image source comprises a digital image source.

22. The system according to claim 21 wherein said digital image source comprises a digital camera.

23. The system according to claim 21 wherein said digital image source comprises a digital video disk player.

24. The system according to claim 16 wherein said image source comprises an analog image source.

25. The system according to claim 1 further including a plurality of controls that permit a user to create a plurality of predetermined task lighting sequences.

26. A system for comforting a person within a room, said system comprising:

a canopy structure for extending away from a ceiling and above the person, said canopy structure having a lower outer surface for facing a room floor, said lower outer surface including at least one light diffusion section shaped to diffuse light away from said canopy structure and into the room, said at least one light diffusion section of said lower outer surface being curved upward from a location spaced inwardly from a boundary of said lower outer surface to a first end of said canopy structure, and at least a portion of the lower outer surface comprising a light deflecting cover including fabric;

16

a lighting system including at least one lighting source is positioned within said canopy structure, said at least one lighting source being capable of projecting light in a direction away from said canopy structure for illuminating a room;

an image display screen extending along a portion of said canopy structure; and

an image source for providing images on said image display screen so that the images can be viewed by the person.

27. An overhead image display structure for extending away from a ceiling of a room, said structure comprising:

a canopy having a vertically curved lower surface for diffusing light into the room, said vertically curved lower surface including an image display screen for receiving and displaying a plurality of images from an image source, a first vertically curved light diffusing section extending from a location proximate said image display screen to a first end of said canopy, a second vertically curved light diffusing section extending in a direction away from said first light diffusing section and said image display screen to a second end of said canopy and a plurality of light emitting sources positioned within said curved lower surface of said canopy for providing predetermined task lighting within said room.

28. The overhead image display structure according to claim 27 further comprising an image source for providing an image on the image display screen.

29. The overhead image display structure according to claim 28 wherein said image source comprises a digital image source.

30. The overhead image display structure according to claim 29 wherein said digital image source comprises a digital video disk player.

31. The overhead image display structure according to claim 29 wherein said digital image source comprises a digital camera.

32. The overhead image display structure according to claim 27 wherein said light emitting sources include a plurality of spaced lamps.

33. The overhead image display structure according to claim 27 wherein each light emitting source comprises a fiber optic cable.

34. The overhead image display structure according to claim 27 wherein said curved lower surface includes a substantially flat portion for deflecting light into the room from a light source.

35. The overhead image display structure according to claim 34 wherein said image display screen is located within said substantially flat portion.

36. The overhead image display structure according to claim 27 further comprising a light diffusion shelf proximate a light source spaced from a lower outer surface of said canopy.

37. An overhead structure for extending away from a ceiling within a room, said structure comprising:

a canopy including a lower outer surface comprising at least a first light diffusion section that is curved upward from a location proximate an image display portion to a first end of said canopy for diffusing light from a lighting source deep into the room, said image display portion comprises an image display screen for receiving images from an image projection system; and said image projection system for delivering said images to said image display screen so that said images can be conveniently viewed by a person within the room.

17

38. The system according to claim 37 further comprising a light diffusion shelf proximate a light source spaced from the lower outer surface of the canopy structure.

39. The light system according to claim 38 wherein said light diffusion shelf includes a light reflective covering.

40. The light system according to claim 39 wherein said light reflective covering comprises a coating including a reflective paint.

41. The system according to claim 38 wherein said light source includes an artificial light source positioned proximate a first end of the canopy proximate said light diffusion shelf.

42. The system according to claim 37 wherein said first end of said canopy is spaced a first distance from the ceiling when said canopy is secured to the ceiling, and wherein said canopy comprises a second light diffusing section having a portion for being spaced a second distance from the ceiling, said second distance being greater than said first distance.

43. The system according to claim 42 wherein said second light diffusing section curves upwardly away from the image display screen to a second end of the canopy.

44. The system according to claim 42 wherein said second light diffusing section extends substantially parallel to the image display screen between a position along the length of the canopy and a second end of the canopy.

45. The system according to claim 37 further comprising at least one light source including a plurality of spaced light sources located within said canopy.

46. The system according to claim 45 wherein said spaced light sources include a plurality of lamps positioned along the lower outer surface of the canopy.

47. The system according to claim 46 wherein said lamps each include a focusing lens.

48. The system according to claim 45 wherein said at least one light source includes at least one row of a fiber optic cable.

18

49. The system according to claim 45 wherein said at least one light source includes a plurality of fiber optic cables secured within said canopy.

50. The system according to claim 45 further including a plurality of controls that permit a user to create a plurality of predetermined task lighting sequences.

51. The system according to claim 37 wherein said image display screen comprises an outer surface covered by a material which permits an image from the image projection system to be displayed.

52. The system according to claim 51 wherein said material includes a coated fabric.

53. The system according to claim 37 wherein a portion of said lower outer surface of the canopy includes a light deflecting cover.

54. The system according to claim 53 wherein said cover includes a fabric.

55. The system according to claim 37 wherein said image projection system includes a rear projection system that is mounted within said canopy.

56. The system according to claim 37 wherein said image projection system includes a projector for displaying still images on said image display portion.

57. The system according to claim 56 wherein said projector is located within the canopy structure.

58. The system according to claim 56 wherein said projector is located outside of said canopy structure.

59. The system according to claim 37 wherein said image projection system comprises a digital image source.

60. The system according to claim 59 wherein said digital image source comprises a digital camera.

61. The system according to claim 59 wherein said digital image source comprises a digital video disk player.

62. The system according to claim 37 wherein said image projection system comprises an analog image source.

* * * * *

UNITED STATES PATENT AND TRADEMARK OFFICE
CERTIFICATE OF CORRECTION

PATENT NO. : 6,870,673 B2
DATED : March 22, 2005
INVENTOR(S) : Archie E. Cromer et al.

Page 1 of 1

It is certified that error appears in the above-identified patent and that said Letters Patent is hereby corrected as shown below:

Column 14,

Line 30, replace "room, said at least" with -- room, at least --.

Line 35, replace "structure said first" with -- structure, said first --.

Signed and Sealed this

Eleventh Day of April, 2006

A handwritten signature in black ink that reads "Jon W. Dudas". The signature is written in a cursive style with a large, looped initial "J".

JON W. DUDAS
Director of the United States Patent and Trademark Office