

- [54] **RESONANT CONVERTERS WITH SECONDARY-SIDE RESONANCE**
- [75] Inventors: Fred C. Lee, Blacksburg; Kwang-Hwa Liu, Drapers Meadow, both of Va.
- [73] Assignee: Virginia Tech Intellectual Properties, Inc., Blacksburg, Va.
- [21] Appl. No.: 856,775
- [22] Filed: Apr. 28, 1986
- [51] Int. Cl.⁴ H02M 3/335
- [52] U.S. Cl. 363/21; 363/97; 363/131
- [58] Field of Search 363/18, 19, 20, 21, 363/97, 131

- 4,593,346 6/1986 Nooijen et al. 363/21
- 4,605,999 8/1986 Bowman et al. 363/97 X
- 4,620,271 10/1986 Musil 323/222 X

FOREIGN PATENT DOCUMENTS

- 530402 6/1976 U.S.S.R. 323/271

Primary Examiner—Patrick R. Salce
 Assistant Examiner—Anita M. Ault
 Attorney, Agent, or Firm—Mason, Fenwick & Lawrence

[57] ABSTRACT

A family of quasi-resonant converters is disclosed as comprising a voltage source, a transformer having primary and secondary windings, and a switch for periodically coupling the voltage source to the primary winding, whereby a charging current appears on the secondary winding. The transformer exhibits a characteristic leakage inductance. A capacitor exhibiting a characteristic capacitance is coupled to the secondary winding to form a resonant circuit including the leakage inductance and the capacitor. The secondary winding is coupled to apply the charging current to the capacitor. A rectifying circuit couples the capacitor to a load, whereby the voltage stored in the capacitor is delivered to the load. The capacitor is directly connected to the secondary winding and to the rectifying circuit to permit positive and negative going voltages to be stored therein, whereby magnetic flux within the core of the transformer is dissipated and the transformer magnetically reset.

[56] References Cited
 U.S. PATENT DOCUMENTS

- 3,582,754 6/1971 Hoffmann et al. 363/18
- 4,016,461 4/1977 Roland 323/282 X
- 4,063,306 12/1977 Perkins et al. 363/56 X
- 4,168,477 9/1979 Burchall 323/222
- 4,253,136 2/1981 Nanko 363/21
- 4,323,845 4/1982 Leach 323/272 X
- 4,415,959 11/1983 Vinciarelli 363/21
- 4,417,197 11/1983 Schwarz 323/272
- 4,441,146 3/1984 Vinciarelli 363/20
- 4,517,633 5/1985 Melcher 363/21
- 4,530,043 7/1985 Palm et al. 363/21
- 4,546,421 10/1985 Bello et al. 363/21
- 4,559,590 12/1985 Davidson 363/21
- 4,585,986 4/1986 Dyer 323/271
- 4,592,763 6/1986 Dietz et al. 323/271 X

14 Claims, 6 Drawing Sheets

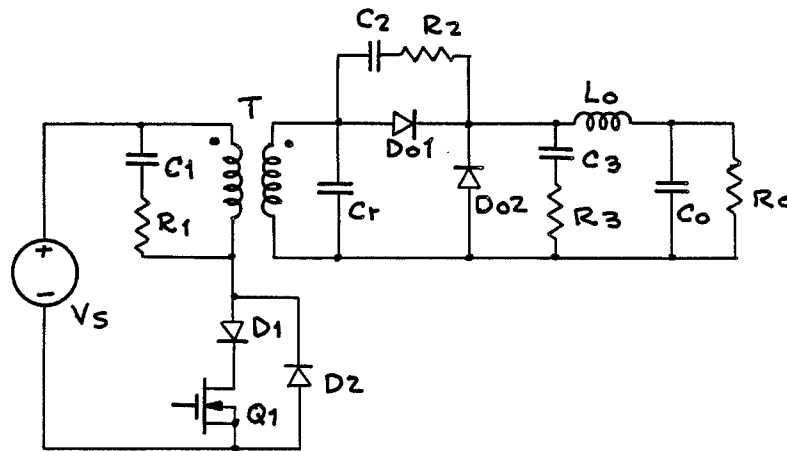

FIG-1A
(PRIOR ART)

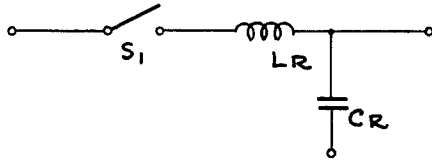

FIG-1B
(PRIOR ART)

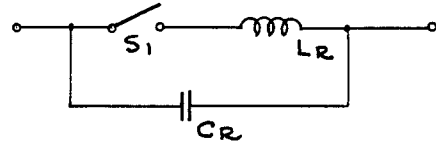

FIG-2A
(PRIOR ART)

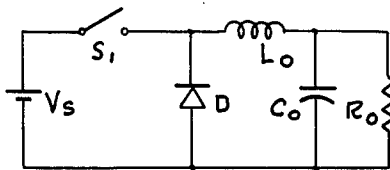

FIG-2B
(PRIOR ART)

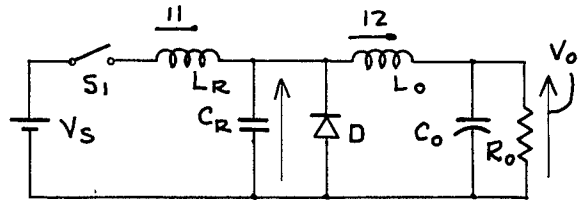
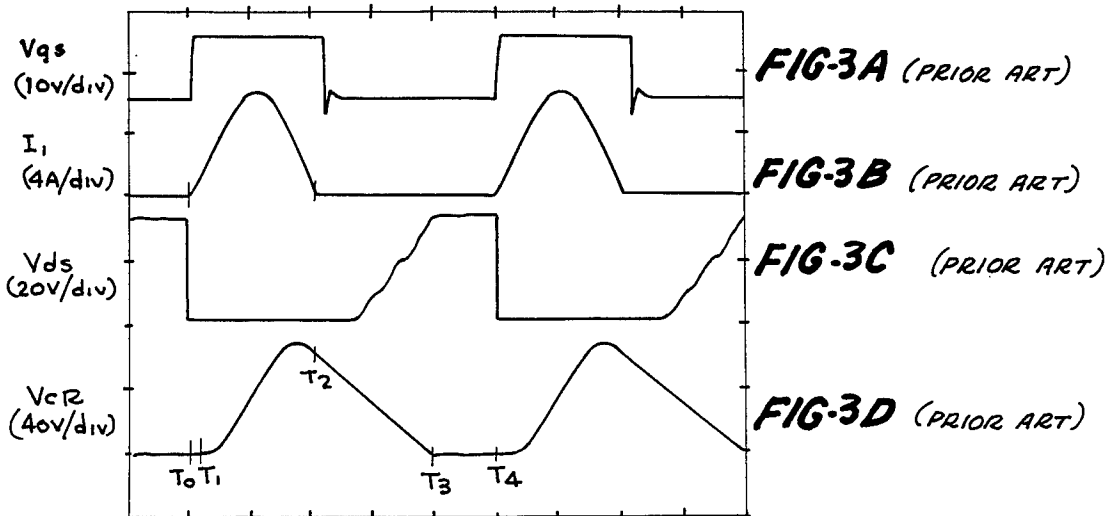
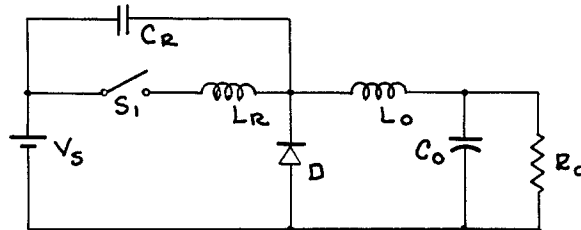

FIG-2C
(PRIOR ART)



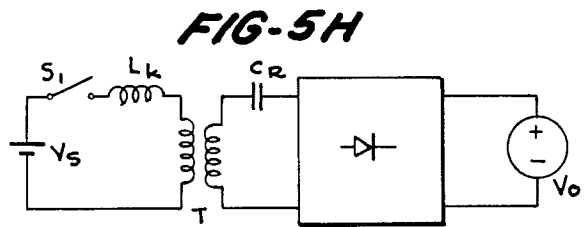
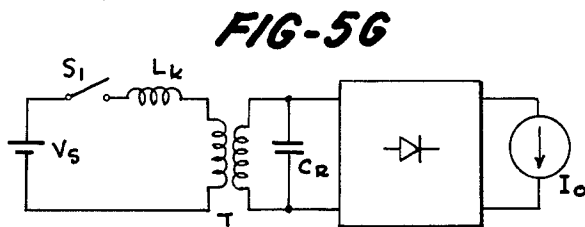
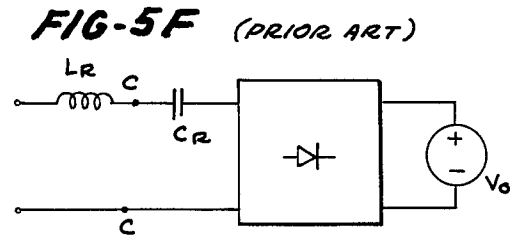
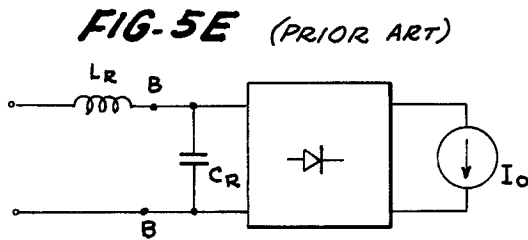
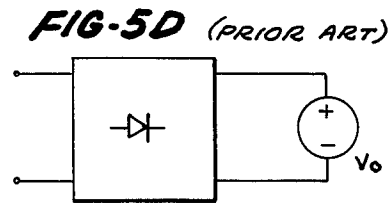
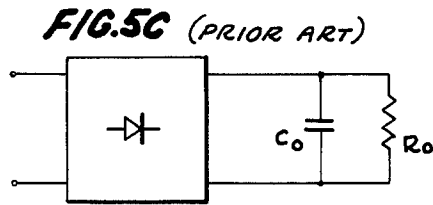
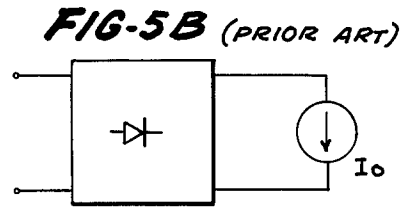
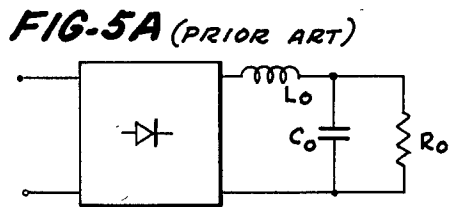
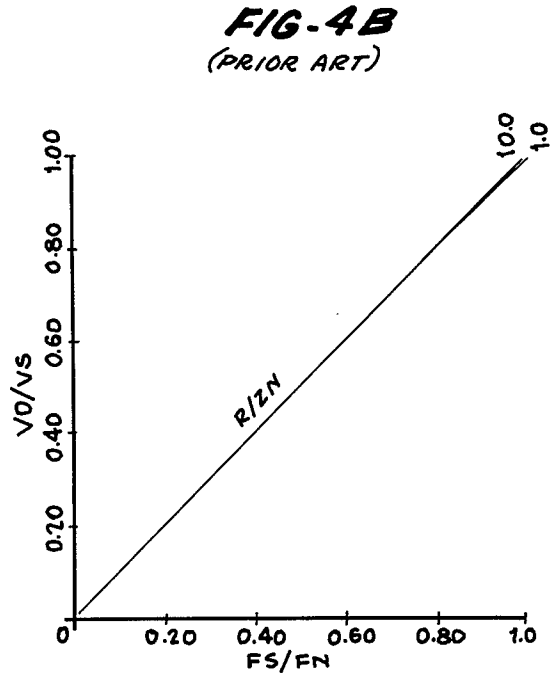
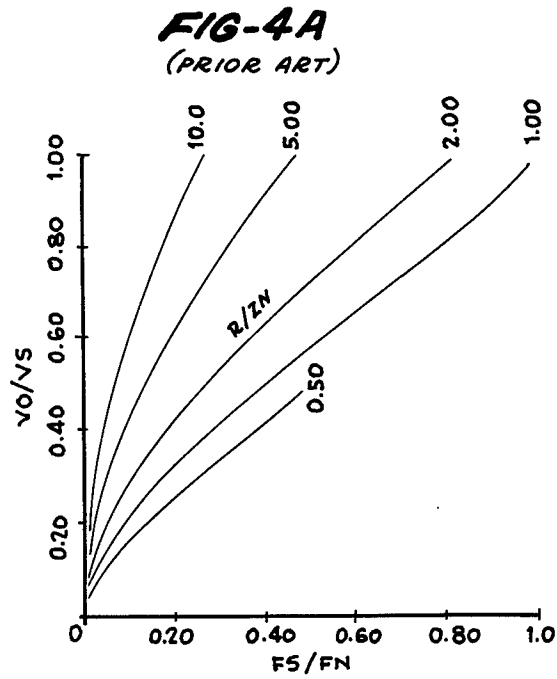

FIG-6A (PRIOR ART)

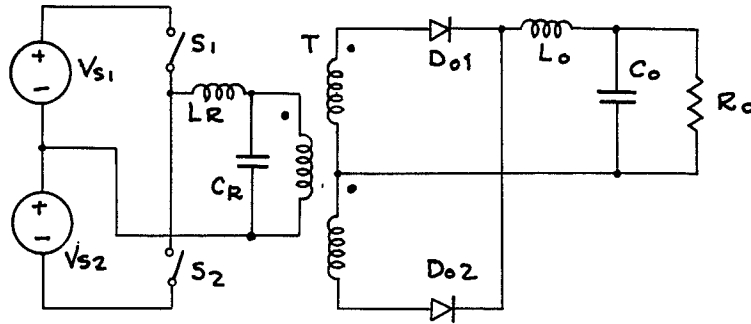

FIG-6B

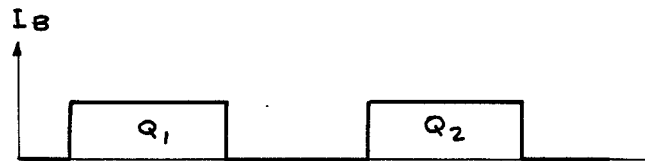
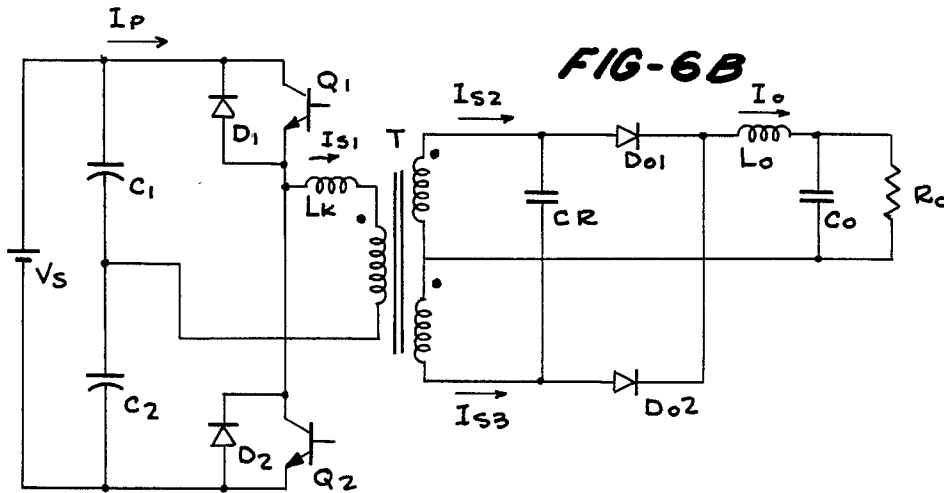

FIG-7A

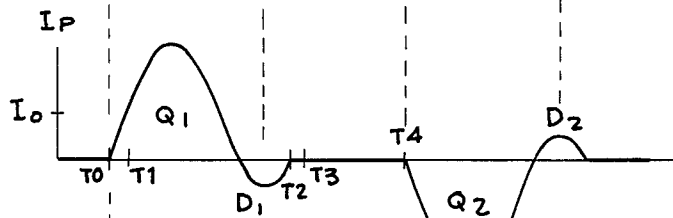

FIG-7B

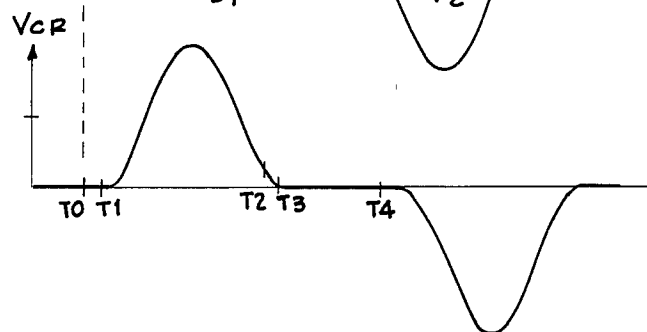

FIG-7C

FIG-8A (PRIOR ART)

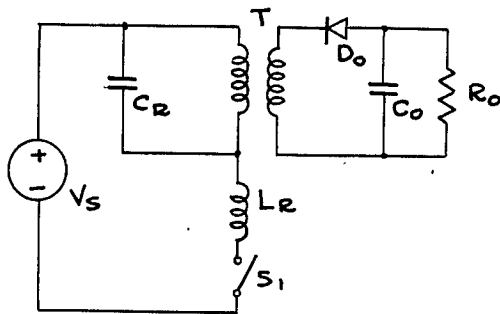

FIG-8B

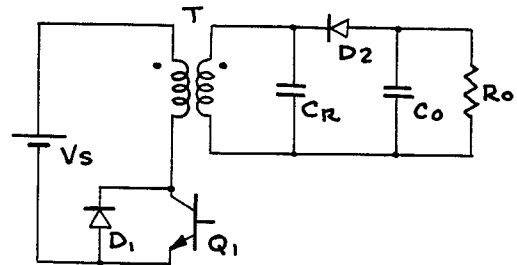

FIG-8C

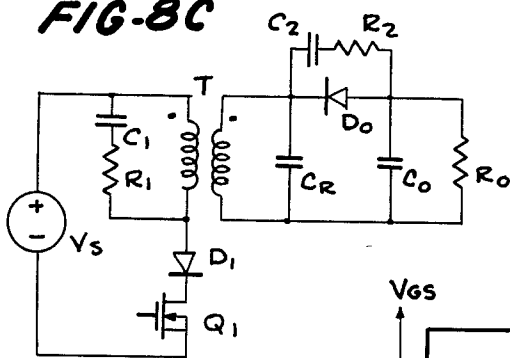

FIG-8D

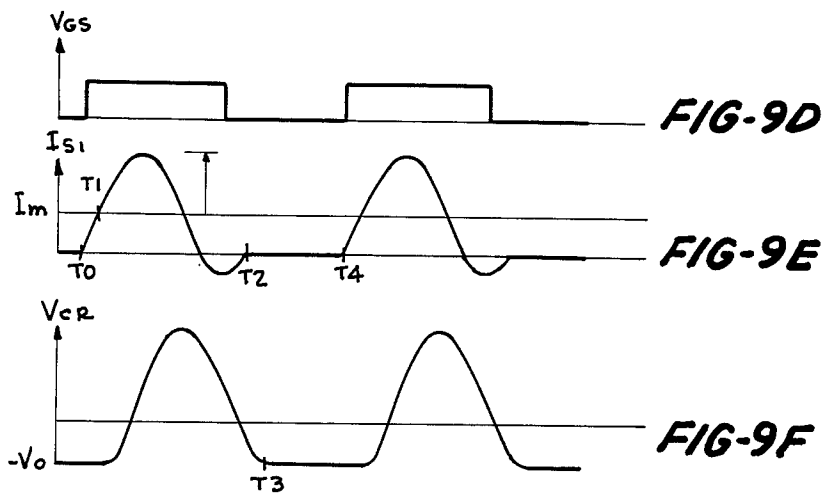
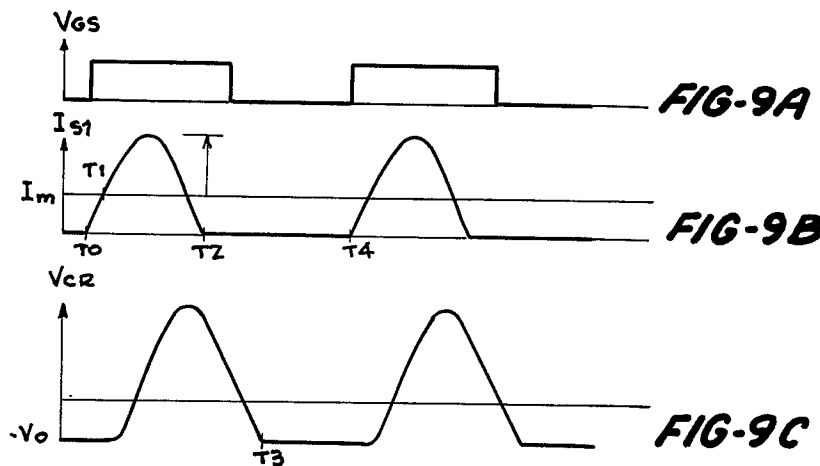
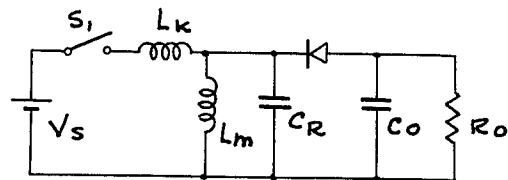

FIG-10A (PRIOR ART)

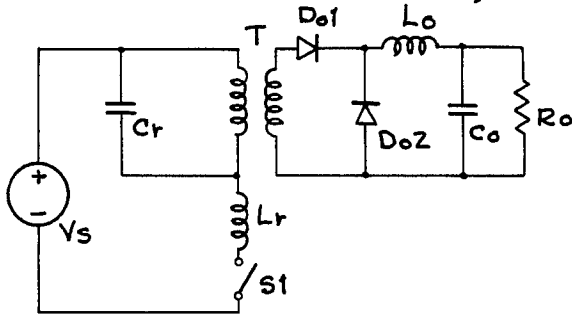

FIG-10B

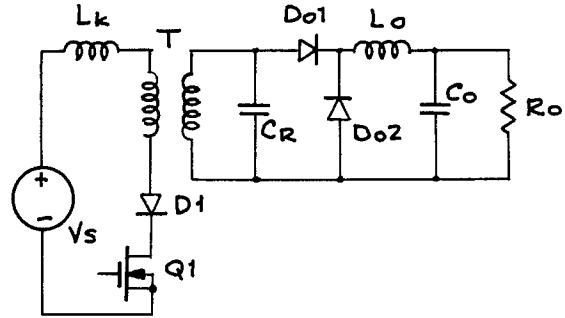

FIG-10C

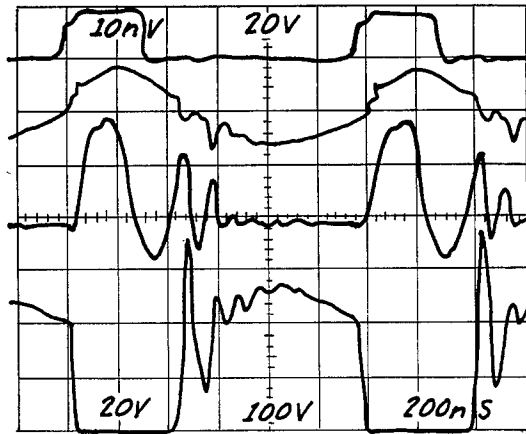
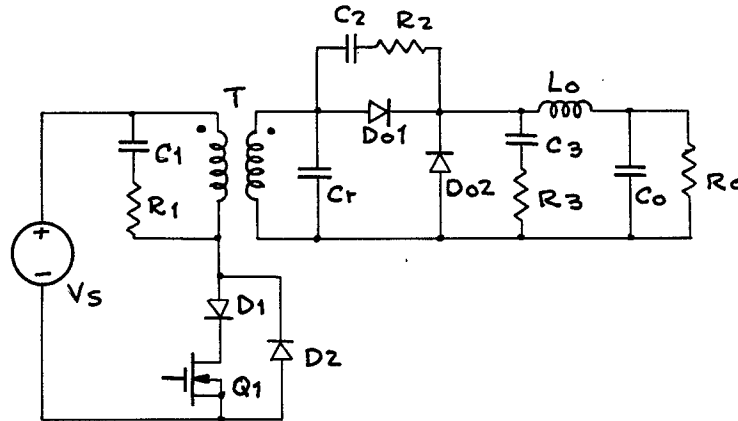

FIG-10D

FIG-10E

FIG-10F

FIG-10G

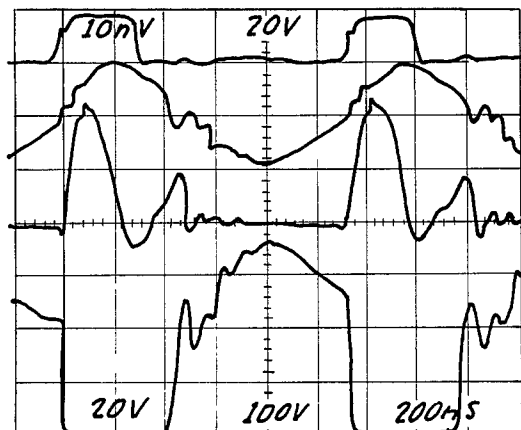

FIG-10H

FIG-10I

FIG-10J

FIG-10K

FIG-11A

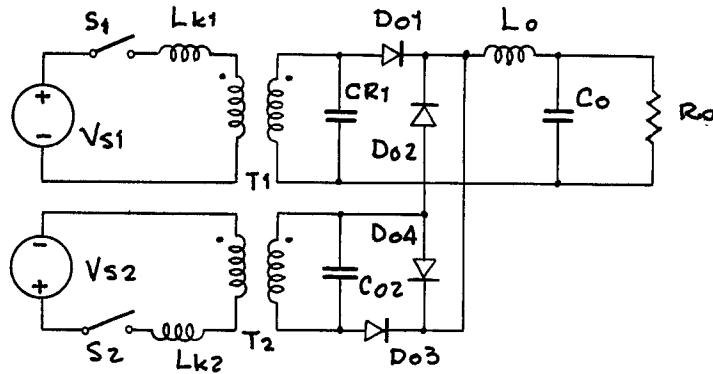

FIG-11B

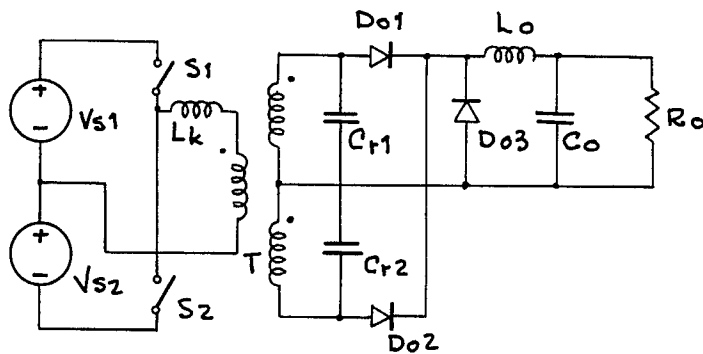

FIG-12

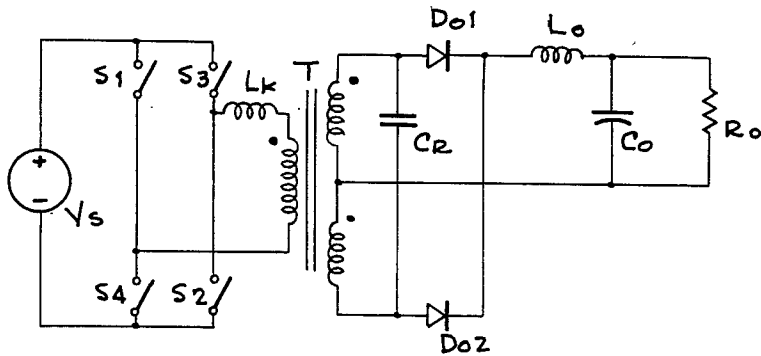
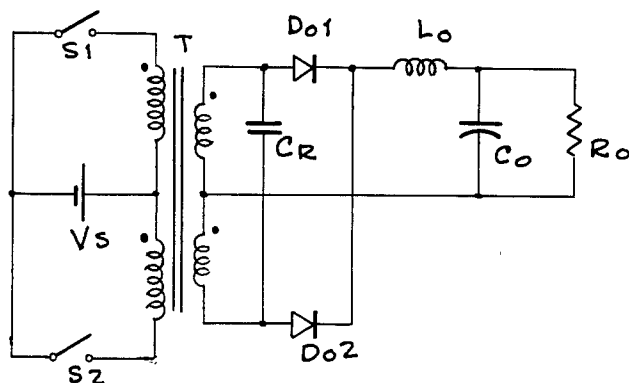

FIG-13



RESONANT CONVERTERS WITH SECONDARY-SIDE RESONANCE

BACKGROUND OF THE INVENTION

1. Field of the Invention:

This invention relates to switching converters particularly adapted to switch at relatively high frequencies and, in particular, to such converters that achieve switching on and off at zero current level, whereby high efficiency at such high frequencies is achieved.

2. Description of the Prior Art:

In conventional resonant switching converters such as DC-to-DC converters, a switching device typically in the form of a semiconductor switch turns on and off repetitively at high current levels to achieve output voltage conversion and regulation. Such converters employ magnetic components such as the energy storage/transfer and ripple/filtering elements. Operating such magnetic components at high frequencies reduces their size and cost. In typical resonant switching converters, the inductive impedance of such magnetic components is coupled in circuit with the semiconductor switches. High frequency switching of such inductive impedances, adversely affects these switches. As the switch is turned on and off rapidly, switching transients involving high levels of current and voltage occur, whereby high switching stresses and losses are imposed upon the semiconductor switch. When such a switch is switched or "forced off", the energy still present in the coupled inductive element imposes high current and high voltage and thus high switching stress and loss on the switch. Furthermore, the pulsating current waveforms resulting from rapid switching, cause severe electromagnetic interaction (EMI) problems as the switching frequency is increased. It is desired to switch such semiconductor switches at relatively high switching frequencies to increase the effectiveness of the voltage control and regulation and, at the same time, minimize the size and cost of the inductive and capacitive elements employed in such converters. However, as the switching frequency increases, the above-noted switching stresses and losses increase and the converter's overall efficiency and reliability decrease.

Snubber circuits are commonly used to alleviate the switching stresses mentioned above. Simple RC or RDC snubber circuits suffer from high power loss at high frequencies. Lossless snubber circuits, on the otherhand, increase circuit complexity considerably.

To overcome these problems of switching stress and loss, the technique of "zero current switching" has been described in "Resonant Switching Power Conversion Technique," by E. E. Buchanan and E. J. Miller, IEEE Power Electronics Specialists Conference, 1975 Record, pp. 188-193 and in "Resonant Switching Power Conversions," by E. J. Miller, IEEE Power Electronics Specialists Conferences, 1976 Record, pp. 206-211. Such "zero current switching" technique utilizes an LC resonant tank circuit to force the current through the semiconductor switch to oscillate, whereby the semiconductor switch turns off at zero current level, thereby drastically reducing switching stresses and losses. However, most of the converters employing this "zero current switching" technique suffers from one or more of the following deficiencies: (1) complicated circuit topology (2) limited range of frequency and power operation, (3) their converter elements require increased voltage and current ratings, (4) complicated

control circuitry, and (5) special start-up or shut-down circuitry.

In "Resonant Switches - A Unified Approach to Improve Performance of Switching Converters," by the inventors of this invention, IEEE International Telecommunications Energy Conference, 1984 Proceedings, pp. 344-351, there is described the use of "resonant switches" in various conventional pulse-width modulated switching converters to achieve "zero-current-switching". Generally, such resonant switches are a subcircuit consisting of a semiconductor switch S_1 , a resonance inductor L_R , and a resonance capacitor C_R . There are two types of resonant switch configurations as shown respectively in FIGS. 1A and B, an L-type and an M-type resonant switch. In both cases, the inductor L_R is connected in series with the switch S_1 to slow down the current change rate, and the capacitor C_R is added as an auxiliary energy storage/transfer element. If switch S_1 is a device without reverse voltage blocking capability or contains an internal anti-parallel diode, an additional diode D_1 is needed and should be connected in series with the switch S_1 and the inductor L_R . The inductor L_R and the capacitor C_R together constitute a series resonant circuit with respect to the switch S_1 . When the switch S_1 conducts, current flows through switch S_1 and inductor L_1 into the capacitor C_1 with a quasi-sinusoidal waveform. As the inductor current drops to zero, the capacitor voltage is charged up with a negative polarity with respect to switch S_1 , thus commutating off the switch S_1 . The resonant switch therefore, provides zero-current-switching properties during both turn-on and turn-off.

A conventional buck converter is illustrated in FIG. 2A, as comprising a switch S_1 for applying upon being rendered conductive a voltage source V_s across a commutation diode D . The commutation diode D is coupled to an output circuit comprised of an output inductor L_o disposed in circuit with an output capacitor C_o connected in parallel with an output resistor R_o . This conventional buck converter is modified as shown in FIG. 2B by the addition of the L-type resonant switch, as first shown in FIG. 1A, between voltage source V_s and the commutation diode D . The output inductance L_o is selected to be much larger than inductance L_R , thus making the resonant frequency of the resonant circuit comprised of capacitor C_o and the inductor L_o much smaller than that of the resonant circuit comprised of the capacitor of C_R and the resonant inductor L_R . It is also assumed that inductors L_o is sufficiently large so that the current I_2 through the inductor L_o , remains relatively constant throughout a switching cycle.

The operation of the buck resonant converter employing the L-type resonance switch as shown in FIG. 2B, will now be explained with reference to the waveforms as shown in FIGS. 3A to 3D. Before time T_o , the semiconductor switch S_1 is turned off, whereby the commutation diode D carries the output current I_o with the capacitor voltage V_{CR} clamped at zero. In the first of four distinct stages, the semiconductor switch S_1 is turned on at time T_o , whereby current I_1 flowing through the semiconductor switch S_1 and the resonant inductor L_R rises linearly as shown in the waveform of FIG. 3B. Between times T_o and T_1 , the output current I_2 shifts gradually from the path through the commutation diode D to the path through the semiconductor switch S_1 and the resonant inductor L_R .

At time T_1 , the current I_1 becomes equal to current I_2 , whereby the commutation diode D is turned off and, as seen in FIG. 3B, the current I_1 begins to charge capacitor C_R . As seen in FIG. 3B, the flow of the current of I_1 through the resonant inductance L_R and the voltage V_{CR} appearing on resonant capacitor C_R is substantially sinusoidal rising to a peak and falling back to zero at time T_2 . As shown in FIG. 3D, the voltage V_{CR} rises to a peak of approximately $2V_s$, shortly before time T_2 , whereby a reverse voltage of $V_{CR}-V_s$ is applied to the semiconductor switch S_1 commutating it off naturally at time T_2 . As shown in FIG. 3B, zero current is flowing in the semiconductor switch S_1 at time T_2 , when it is commutated off. As shown in FIG. 3D, the capacitor C_R discharges in the time interval from time T_2 to time T_3 . The capacitor voltage V_{CR} drops linearly to zero at time T_3 . In the fourth stage from time T_3 to time T_4 , the output current I_2 flows through the commutation diode D and, with the switch S_1 open, the resonant capacitor C_R is clamped to zero voltage. At time T_4 , the switch S_1 turns on again, starting the next switching cycle.

FIG. 2C shows a buck resonant converter circuit in which the resonant capacitor C_R is coupled in parallel between the voltage source V_s and the resonant inductor L_R instead of in parallel with the commutation diode, whereby an M-type resonant switch, as shown first in FIG. 1B, is formed. The modified buck resonant converter of FIG. 2C operates in four stages in a manner similar to the operation of the buck resonant converter as described above with respect to FIG. 2B.

The operation of the converter circuits with the L-type and M-type resonant switches as shown in FIGS. 2B and 2C, is in the half-wave mode as shown in FIG. 3B. In other words, the current I_1 is permitted to flow through the switch S_1 in but a single direction. As will be explained below, these resonant converters as operated in the half-wave mode suffer from a drawback, namely, the DC voltage conversion ratio is sensitive to load variations.

Many DC-to-DC converters incorporate a transformer in order to step-up or -down the output voltage. One difficulty arising out of the incorporation of a transformer, results from the inherent leakage inductance L_k of the transformer. Typically, the leakage inductance L_k of the transformer is coupled to a semiconductor device, which is turning on and off at a relatively high frequency. As the semiconductor switch S_1 couples the leakage inductance L_k with other inductive or magnetic components of the converter, spikes or noise occur across the switch. The transformer also serves to provide isolation between the voltage source V_s and the output voltage V_o .

U.S. Pat. No. 4,415,959 of Vinciarelli discloses a DC-to-DC forward converter incorporating a transformer and forming an effective LC circuit between the leakage inductance L_k of the transformer and a resonant capacitor coupled by an unidirectional conducting device such as a diode to the secondary coil of the transformer. A switch couples the input voltage V_s to the primary winding and is turned on and turned off at a relatively high frequency, whereby a series of switching cycles occur and energy transfers from the input voltage V_s to the output is achieved. The resonant capacitor is cyclically charged and discharged to deliver its energy to the load. Vinciarelli clearly states that the storage capacitor operates in a half-wave mode and, further, does not, even fractionally, return any energy to the leakage inductance L_k . Evaluation of Vinciarelli's

converter indicate problems with the incorporation of its transformer and, in particular, of the magnetic flux resetting of the transformer at the end of each cycle in preparation for the next, i.e. Vinciarelli does not apply any negative voltage to the secondary coil or the primary coil of his transformer as would effect such magnetic resetting. If magnetic resetting is not carried out and the magnetic flux within the transformer continues to increase with each switching cycle, the input or primary current passing through the switch, rises quickly to a point where the switch and possibly the transformer are destroyed due to the saturation of the transformer. To overcome these problems, Vinciarelli proposes in his later U.S. Pat. No. 4,441,146, an auxiliary switch actuated during the off period of the primary switch for resetting his transformer. Such auxiliary switch adds complexity and cost to the resulting DC-to-DC converter.

SUMMARY OF THE INVENTION

It is an object of this invention to provide a family of new and improved resonant converters named quasi resonant converters which eliminate switching stresses and losses.

It is a more particular object of this invention to provide a family of new and improved resonant converters, employing switches that turn on and off at zero current conditions.

It is a still further object of this invention to provide a family of new and improved resonant converters, which incorporates a transformer for stepping-up or-down the input, supply voltage and utilizes the transformer leakage inductance in a resonant circuit to achieve switch commutation under zero current conditions.

It is a still further object of this invention to provide a family of new and improved resonant converters employing a transformer and operative in a half-wave mode.

It is a still further object of this invention to provide a family of new and improved resonant converters employing a transformer and operating in a full-wave mode, whereby the converter's voltage conversion ratio is made substantially independent of the variations in the load imposed upon the converter.

It is a still further object of this invention to provide a family of new and improved resonant converters incorporating a transformer and a resonant circuit including the leakage inductance of the transformer, for achieving zero current switching, as well as effective magnetic resetting of its transformer without the use of complex auxiliary control circuitry.

In accordance with these and other objects of this invention, there is disclosed a family of quasi resonant converters comprising a voltage source, a transformer having primary and secondary windings, and a switch for periodically coupling the voltage source to the primary winding, whereby a charging current appears on the secondary winding. The transformer exhibits a characteristic leakage inductance. A capacitor exhibiting a characteristic capacitance is coupled to the secondary winding to form a resonant circuit including the leakage inductance and the capacitor. The secondary winding is coupled to apply the charging current to the capacitor. A rectifying circuit couples the capacitor to a load, whereby the voltage stored in the capacitor is delivered to the load. The capacitor is directly connected to the secondary winding and to the rectifying

circuit to permit positive and negative going voltages to be stored therein, whereby magnetic flux within the core of the transformer is dissipated and the transformer magnetically reset.

In a further aspect of this invention, the switch includes a diode connected to conduct in an opposite fashion to that of the switch, whereby the switch may be actuated to apply a current flow from the voltage source to the primary winding of the transformer and upon being deactuated, permit a current flow, in an opposite direction, from the primary winding to the voltage source, whereby the resonant switching converter is operative in a full-wave mode.

BRIEF DESCRIPTION OF THE DRAWINGS

A detailed description of a preferred embodiment of this invention is hereafter made with specific reference being made to the drawings in which:

FIGS. 1A and 1B are respectively an L-type and an M-type resonant switch, as known in the prior art;

FIGS. 2A, 2B, and 2C are respectively a conventional buck converter, a buck resonant converter incorporating the L-type resonant switch as shown in FIG. 1A, and a buck resonant converter incorporating the M-type resonant switch as shown in FIG. 1B, all known in the prior art;

FIGS. 3A, 3B, 3C and 3D are respectively waveforms occurring in the course of the operation of the buck resonant converter as shown in FIG. 2B;

FIGS. 4A and 4B show plots of the voltage conversion ratio, i.e. the ratio of the output voltage V_o to the supply voltage V_s , as a function of the ratio of the switching frequency F_s to the resonant frequency F_n of the resonant circuit incorporated within a resonant converter, operating in a half-wave mode and a full-wave mode, respectively;

FIG. 5A shows in circuit form a current load for a resonant converter, FIG. 5B shows a diagrammatic representation of the circuit elements of the current load as shown in FIG. 5A, and FIG. 5C shows the circuit elements of a voltage load, and FIG. 5D shows a diagrammatical representation of the circuit elements of the voltage load shown in FIG. 5C, all known in the prior art;

FIGS. 5E and 5F show respectively a parallel resonant converter as coupled via a rectifying circuit to a current load and a series resonant converter coupled via a rectifying circuit to a current load, all known in the prior art;

FIGS. 5G and 5H show respectively the incorporation, in accordance with the teachings with this invention, of a transformer into the parallel and series resonant converters;

FIGS. 6A and 6B are respectively circuit diagrams of a half-bridge parallel resonant converter employing a resonant capacitor connected on the primary side of its transformer as known in the prior art, and a half-bridge parallel resonant converter employing a resonant capacitor connected on the secondary side of its transformer in accordance with the teachings of this invention;

FIGS. 7A, 7B and 7C show respectively different waveforms of the circuit elements of the half-bridge parallel resonant converter operating in the full-wave mode, as shown in FIG. 6B;

FIGS. 8A, 8B, 8C and 8D show respectively a circuit diagram of a flyback quasi-resonant converter of the prior art, a flyback quasi-resonant converter disposing

the resonant capacitor on the secondary side of the transformer, a detailed circuit diagram of a tested flyback quasi-resonant converter, and the equivalent circuit of the flyback quasi-resonant converter as shown in FIG. 6B;

FIGS. 9A, 9B, and 9C show the waveforms of the circuit elements of the circuits of FIGS. 8B, 8C and 8D operated in a half-wave mode, whereas FIGS. 9D, 9E and 9F show the waveforms of the circuit elements of FIGS. 8B, 8C and 8D in a full-wave mode;

FIGS. 10A, 10B, and 10C show respectively the circuit diagrams of a forward quasi-resonant converter employing a resonant capacitor connected on the primary side of the transformer as known in the prior art, a forward quasi-resonant converter employing a resonant capacitor connected on the secondary side of the transformer and operative in a half-wave mode in accordance with the teachings of this invention, and a forward quasi-resonant converter employing a resonant capacitor connected on the secondary side of its transformer and operative in a full-wave mode in accordance with the teachings of this invention;

FIGS. 10D, 10E, 10F and 10G show the waveforms of the circuit elements of the circuit of FIG. 10C, as operative in a full-wave mode, whereas FIGS. 10H, 10I, 10J, and 10K show the waveforms of the circuit elements, without the diode D_2 , of the circuit of FIG. 10C, as operative in a half-wave mode;

FIGS. 11A and 11B are respectively circuit diagrams of two forward quasi-resonant converters connected in back-to-back arrangement, and a modified arrangement of such a circuit to provide a half-bridge parallel resonant converter;

FIG. 12 is a full-bridge parallel resonant converter employing secondary side resonance; and

FIG. 13 is a push-pull parallel resonant converter employing secondary side resonance.

DETAILED DESCRIPTION OF A PREFERRED EMBODIMENT

Before describing a preferred embodiment of this invention, it is necessary to understand certain topological relationships between the employed resonant switch and its load. During the steady-state operation of a resonant converter circuit, its load circuit appears either as a constant-current sink, or a constant-voltage sink to the converter. Illustratively, a load circuit comprising an output-filtering inductor L_o connected in series with a parallel circuit comprised of an output-filtering capacitor C_o and an output resistor R_o as shown in FIG. 5A, is deemed to be a current load as diagrammatically illustrated in FIG. 5B. By contrast, a load containing only the parallel circuit of the output-filtering capacitor C_o and the resistor R_o as shown in FIG. 5C, is regarded as a voltage load as diagrammatically illustrated in FIG. 5D. A rectifying circuit, as identified by the circuit block bearing the diode, provides a rectified voltage to the loads, in each of FIGS. 5A, 5B, 5C, and 5D.

There are two basic types of resonant converters, the parallel resonant converter (PRC), wherein output power to the load is tapped from the resonant capacitor C_R of the circuits LC resonant tank circuit, as shown in FIG. 5E, and a series resonant converter (SRC), wherein the output power is derived from the current drawn through the resonant inductor L_R , as shown in FIG. 5F. A voltage source V_s and a corresponding semiconductor switching device S_1 (neither shown) is employed with each of the converters of FIGS. 5E and

5F. In the PRC, the voltage imposed on the resonant capacitor C_R is rectified and fed into a current load, while in the SRC, the current flowing through the resonant inductor L_R (and its resonant capacitor C_R) is rectified by an appropriate circuit identified by the circuit block bearing the diode and fed into a voltage load. This constraint of employing a particular load type for the PRC or the SRC is required to avoid interference between a particular load circuit and a particular resonant tank circuit. Consider the case where a constant voltage load would be connected to the output of a PRC. Typically, a square-wave voltage is reflected from the voltage load as shown in FIG. 5F and would appear in the hypothetical situation across the resonant capacitor C_R . However, in the normal operation of a PRC, the voltage across the resonant capacitor C_R as shown in FIG. 5E has a smooth quasi-sinusoidal wave form, which would conflict with the square-wave voltage reflected from the constant voltage load. Therefore, the PRC cannot support a voltage load. Similarly, the SRC cannot support a current load.

FIGS. 5G and 5H illustrate respectively the incorporation in accordance with the teachings of this invention of a transformer T into each of a PRC and a SRC and of utilizing the transformer's leakage inductance L_K and the resonant capacitor C_R to form the converter's LC resonant tank circuit. As shown in each of FIGS. 5G and 5H, the resonant capacitor C_R is coupled to the secondary coil of the transformer T. The term, secondary-side resonance, is introduced to describe the technique of using the leakage inductance L_K and the resonant capacitor C_R as coupled on the secondary side of the transformer T, to form the converter's resonant tank circuit. As will be described in detail below with respect to the detailed embodiments of this invention, the semiconductor switch S_1 is switched on and off at zero-current conditions. In addition, the incorporation of a transformer T, as had posed the problems of imposing voltage spikes and noise on semiconductor switching devices, is now positively employed as the resonant element in the converter's resonant tank circuit. The capacitor voltage V_{CR} is rectified before being applied to the converter's load. The circuit block bearing the diode is a general representation of a rectifying circuit and may take the form of any of a number of well known rectifying circuits. The basic PRC and SRC as illustrated in FIGS. 5G and 5H may be incorporated as will be demonstrated below in a family of similar circuits.

The PRC as first shown in FIGS. 5E is incorporated into a half-bridge converter of the prior art, as shown in FIG. 6A. To incorporate secondary-side resonance into such a prior art circuit, the resonant capacitor C_R is transferred to the secondary side of its transformer T. The basic topology of the half-bridge quasi-resonant converter circuit is shown in FIG. 6B. The input voltage source V_s is divided into two equal voltage sources by a voltage divider comprised of series connected capacitors C_1 and C_2 . Switches S_1 and S_2 take the form of the semiconductor switch devices Q_1 and Q_2 , which can be bipolar transistors or MOSFET devices, and the corresponding anti-parallel diodes D_1 and D_2 . Transformer T provides a DC isolation between the input voltage source V_s and the current load comprised of output-filter inductor L_o , output-filter capacitor C_o and output resistor R_o . The resonance capacitor C_R is connected across the center-tapped secondary winding of the transformer T, and is followed by the rectifier di-

odes D_{o1} and D_{o2} , the output-filter inductor L_o , the output-filter capacitor C_o , and the output resistor R_o .

The forward quasi-resonant converter as shown in FIG. 6B includes the MOSFET devices Q_1 and Q_2 connected respectively with the anti-parallel diodes D_1 and D_2 to operate in a full-wave mode and to exhibit the waveforms as shown in FIGS. 7A, 7B and 7C. As will now be explained, the forward quasi-resonant converter of FIG. 6B operates in four distinct states. Before time T_o , the output current I_o is kept constant by the relatively large value of the output-filter inductor L_o , both of the MOSFETs Q_1 and Q_2 are off, capacitor voltage V_{CR} on the resonant capacitor C_R is zero, and the output current I_o is free-wheeling through diodes D_{o1} and D_{o2} . At time T_o of the first or linear state, MOSFET Q_1 turns on, whereby the input current I_p flows into the transformer T and rises linearly as shown in FIG. 7C.

In the second or resonant state, diode D_{o2} stops conducting at time T_1 when the transformer secondary current I_{s2} reaches the level of the output current I_o . The transformer secondary current I_{s2} then starts to charge up the resonant capacitor C_R on the secondary side of the transformer T. Due to the resonance circuit formed by the leakage inductance L_K and the resonant capacitor C_R , the input current I_p oscillates in a sinusoidal fashion and reverses its direction after a certain time interval. The negative current flows back to the capacitor C_1 through the anti-parallel diode D_1 . The MOSFET Q_1 remains conductive as long as the input current I_p is positive. When the input current I_p goes negative, the MOSFET Q_1 turns off at zero current, and the anti-parallel diode D_1 is rendered forward biased to conduct the negative going input current I_p . As the MOSFET Q_1 is completing a resonant cycle, a packet of input energy is transferred to and stored in the resonant capacitor C_R .

After D_{o1} is off at time t_2 , the third or recovering stage starts, in which capacitor C_r keeps discharging its energy into the current load until time t_3 , when its charge is depleted.

At time T_3 , the fourth or free-wheeling state begins, wherein both diodes D_{o1} and D_{o2} conduct and carry the free-wheeling current through the output-filter inductance L_o . At time T_4 , the MOSFET Q_2 turns on again and starts the other half cycle. Input energy in this half cycle is supplied by the voltage imposed on capacitor C_2 , and the capacitor voltage V_{CR} on the resonant capacitor C_R is charged to a polarity opposite to that of the first half cycle.

Typical waveforms of the forward quasi-resonant converter circuit are illustrated in FIGS. 7A, 7B and 7C. The zero current switching property is evidenced by examining the current and voltage waveforms, i.e. the input current I_p is zero when any of the MOSFETs Q_1 and Q_2 , or the anti-parallel diodes D_1 and D_2 turn off and on. Also the fact that the energy is transferred to the output in a packet form suggests that the voltage regulation can be achieved by varying the turn-on repetition rate (i.e. the switching frequency F_s of the MOSFETs Q_1 and Q_2). The resonant frequency F_n is defined as:

$$F_n = 1/(2\pi \sqrt{L_K C_R}).$$

The value of leakage inductance L_K is determined by the transformer's core material and winding technique. An

external inductor can be added in series with the transformer T if the intrinsic leakage inductance L_K is too small.

As shown in FIG. 7C, the input current I_p goes in both a negative and a positive direction, whereby it is said that the half-bridge parallel resonant converter as shown in FIG. 6B, operates in a full-wave mode. By contrast, the buck converter with the L-resonant switch as shown in FIG. 2B, is said to operate in a half-wave mode. As shown in FIG. 3B, the input current I_1 of this buck converter does not go negative and there is no corresponding transfer of energy to the voltage source V_s . Further, FIG. 4A shows the output-to-input voltage conversion ratio V_o/V_s as a function of the normalized frequency, i.e. the ratio of the switching frequency F_s to the resonant frequency F_n as defined above. As the ratio of R_o/Z_N decreases from 10 to 0.5 corresponding to an increase of load, a distinct graph for each of such loads is shown as a function of the normalized frequency. R_o , as explained above, is the resistive component of the converter's load, and Z_N is the characteristic impedance calculated as

$$Z_N = \sqrt{L_K/C_R}.$$

Thus, the buck resonant converter of FIG. 2B exhibit significantly different voltage conversion ratios as its load changes. By contrast, the half-bridge parallel resonant converter of FIG. 6A operates in a full-wave mode as illustrated particularly in FIG. 7C, exhibiting a set of voltage conversion ratios as seen in 4B. As shown, the load on the half-bridge parallel resonant converter may vary significantly, i.e. the ratio R/Z_N may vary from 10 to 1, without significantly changing the voltage conversion ratio. FIG. 4B suggests that the voltage regulation of the half-bridge parallel resonant converter of FIG. 6A, may be dependent upon the normalized switching frequency F_s/F_n . Noting that the resonant frequency F_n remains substantially constant once the elements of the circuit are set, the desired conversion ratio may be set in this embodiment by determining the switching frequency F_s .

The resonant frequency F_n is dependent as defined above upon the values of the leakage inductance L_R and the resonance capacitor C_R . The resonance frequency F_n determines the period and frequency of the oscillations of the input current I_p , as shown in FIG. 7B. As shown in FIG. 7C, the period and frequency of the oscillation of the resonant capacitor voltage V_{CR} is dependent upon the values of the resonant capacitor C_R and the magnetic inductance L_m of the transformer T. When the current flows from the secondary of the transformer T to the resonant capacitor C_R , the resonant capacitor C_R is charged with an oscillating voltage as shown in FIG. 7C. The period and frequency of the waveform shown in FIG. 7C, is dependent upon the values of the resonant capacitor C_R and the magnetic inductance L_M of the transformer T. As may be observed in FIGS. 7A, 7B, and 7C, the switching frequency F_s of the transistors Q_1 and Q_2 must be set lower than the frequencies of the waveforms of FIGS. 7B and 7C, to permit the input current I_p and the resonant voltage V_{CR} to return to zero before the next half cycle of operation.

The operation of the half-bridge parallel resonant converter, as shown in FIG. 6B permits the voltage appearing on the resonant capacitor C_R to go negative

and positive cyclically, noting that the area under the positive and negative going curves are substantially equal as shown in FIG. 7C. It is understood that if the transformer T were not magnetically reset, the magnetic flux within the core of the transformer T would rapidly increase and within a few switching cycles, the current I_p flowing to the primary winding thereof will increase substantially and destroy the semiconductor devices Q_1 and Q_2 , if not the transformer T, itself. By operating the full-bridge parallel resonant converter to apply both positive and negative voltages to the secondary of the transformer T, any magnetic flux built up within the first half-cycle, is dissipated in the second.

A family of converters known generally as single-ended quasi-resonant converters will be first described. In particular, a single-ended resonant converter such as a flyback converter will be described with regard to FIGS. 8A, 8B, 8C, and 8D. A flyback converter of the prior art is illustrated in FIG. 8A with an L-type resonant switch comprised of a resonant capacitor C_R , a resonant inductor L_R and a switch S_1 , similar to that shown in FIG. 1A. To employ secondary-side resonance the resonant capacitor C_R is moved to the secondary side and is coupled across the secondary coil of the transformer T, as illustrated in FIG. 8B. Further, the resonant inductor L_R is removed, it being essentially replaced by the leakage inductance L_K of the transformer T.

An equivalent circuit of the flyback converter shown in FIG. 8B is illustrated in 8D, wherein the magnetizing inductance L_m is shown as being coupled in parallel with the resonant capacitor C_R . Assuming that the value of the magnetizing inductance L_m is large, the current through the magnetizing inductance L_m can be treated as constant during a switching cycle. The operation in terms of four stages of the flyback converter as illustrated in FIGS. 8B and 8D will be explained with respect to the waveforms of FIG. 9. If the switch S_1 is implemented by a semiconductor device Q_1 and a diode D_1 coupled in series with each other as illustrated in FIG. 8C, the resulting switch circuit may only conduct current in the forward biased direction of the diode D_1 and the circuit is confined to operate only in a half-wave mode as illustrated by the waveforms of FIGS. 9A, 9B, and 9C. On the other hand, if the switch S_1 consists of a semiconductor switching device Q_1 and a diode D_1 connected in parallel therewith so as to conduct in an opposite direction, the resultant flyback converter is capable of operating in a full-wave mode as illustrated in FIGS. 9D, 9E and 9F. The Diode D_1 so connected is known as an anti-parallel diode. As a review of the waveforms will indicate, the flyback converter of FIG. 8C has incorporating the transformer T_1 and utilizing secondary side resonant operates to provide the waveforms of FIGS. 9A, 9B and 9C in a half-wave mode similar to that shown and described above for the buck converter shown in FIG. 2B. The flyback converter as shown in FIG. 8B with the anti-parallel diode D_1 operates to provide the waveforms of FIG. 9D, 9E and 9F in a fullwave mode similar to the forward converter as will be described with respect to FIG. 10B and 10C.

The flyback converter as shown in FIG. 8C has been built to deliver 30 W and operate at a switching frequency of 800k Hz, i.e. its switch in the form of the FET Q_1 is switched on and off at a rate of 800k Hz. A list of illustrative components and impedance values thereof, is provided below:

Transformer T:
 TDK P2213-H6F/A250
 14T/1T
 Q1: IRF 730
 D1: TRW-DSR-5500X
 Do: IR 31DQ06*2
 Cr: 0.1u
 Co: 1.0u + 1000u
 C1: 56u
 R1: 1 K Ω
 C2: 820u
 R2: 36 Ω

In FIG. 10A, a forward converter of the prior art is shown as incorporating an L-type resonant switch of the type illustrated in FIG. 1A. This prior art circuit can be transformed to utilize secondary-side resonance by shifting the resonant capacitor C_R to be coupled in parallel across the secondary coil of its transformer T. Such a forward converter with secondary-side resonance as illustratively shown in FIG. 8C has been built and tested to deliver 30 W at a switching frequency of 800 kHz. The waveforms appearing on the circuit elements of the forward converter as shown in FIG. 10C as operating in its full-wave mode, are shown in FIGS. 10D, 10E, 10F, and 10G. The resonant capacitor C_R provides a flux reset mechanism for the transformer. After the FET Q_1 turns off, the magnetizing current flows to the resonant capacitor C_R from the secondary winding of the transformer T, and the voltage on the resonant capacitor C_R goes negative as shown in FIG. 10E during the off-state of the FET Q_1 . As explained above, the application of the negative voltage to the transformer T dissipates the magnetic flux otherwise built up within the core of the transformer T, thereby preventing the primary current I_p from increasing to that point that would destroy the FET Q_1 and possibly the transformer T, itself. After the magnetizing current is reset to zero, it is forced back into the reverse direction. The slight over-reset is advantageous, since it leads to better balance flux excitation of the transformer T. Another advantage is the elimination of the reset winding and a high voltage diode, which are usually required in the conventional forward converter.

FIGS. 10H, 10I, 10J, and 10K illustrate the waveforms of the circuit elements of the forward converter of FIG. 10C without its anti-parallel diode D_2 as the converter operates in its half-wave mode. Observation of the waveforms of FIGS. 10D, 10E, 10F, and 10G, and FIGS. 10H, 10I, 10J, and 10K, indicate that it is necessary to set the resonant frequency F_n of the resonant circuit comprised of the resonant capacitor C_R and the leakage inductor L_K , as well as the resonant frequency of the voltage appearing on the capacitor C_R as set by the resonant capacitor C_R and the magnetic inductance L_m of the transformer T, higher than the switching frequency F_s of the FET Q_1 . Further, observation of the waveforms of FIGS. 10E and 10I, indicative of the voltage appearing on the resonant capacitor C_R in each of the full-wave and half-wave modes of operation, indicates that the areas under the positive and negative going portions of these curves are equal, whereby the transformer T is reset magnetically in both modes.

Referring to FIG. 11A, two identical forward converters similar to the circuit of FIG. 8B, are connected back-to-back to form the converter of FIG. 11A. This circuit may be modified to provide the half-bridge PRC of FIG. 11B by incorporating a transformer T having a

centertapped secondary winding. The converter of FIG. 11 resembles closely the half-bridge parallel resonant converter as shown and described with respect to FIG. 9B.

A full-bridge parallel resonant converter is shown in FIG. 12, wherein the two voltage sources V_{S1} and V_{S2} of the converter of FIG. 11 are replaced with a single voltage source V_s and four switches S_1 , S_2 , S_3 and S_4 are coupled as shown in FIG. 12. In operation, switches S_1 and S_2 are closed simultaneously, while both of switches S_3 and S_4 remain open during a first half of the switching cycle to apply a positive voltage to the primary winding of the transformer T. In the second half of the cycle, the switches S_3 and S_4 are both closed, and switches S_1 and S_2 are both opened, whereby a negative potential is applied to the primary winding of the transformer T.

FIG. 13 shows a push-pull parallel resonance converter employing a single voltage source V_s , a pair of switches S_1 and S_2 and a transformer T with a split, centertapped primary winding. The switch S_1 is closed and switch S_2 is opened during the first half cycle, whereby a positive voltage is output on the secondary winding of the transformer T. In the second half of the cycle, switch S_2 is closed and switch S_1 is opened, whereby a negative potential appears on the secondary winding of the transformer T.

In considering this invention, it should be remembered that the present disclosure is illustratively only and the scope of the invention should be determined by the appended claims.

We claim:

1. A quasi-resonant converter comprising:

- (a) a voltage source;
- (b) a transformer having a primary winding and a secondary winding, said transformer exhibiting a characteristic leakage inductance;
- (c) switch means operating periodically at a switching frequency F_s for coupling said voltage source to said primary winding, whereby a charging current is delivered to said secondary winding;
- (d) a capacitor exhibiting a characteristic capacitance and directly coupled to said secondary winding to form with said characteristic leakage inductance a resonant circuit therewith having a resonant frequency determined by the values of said capacitor and said characteristic leakage inductance so that its resonant frequency is greater than F_s , said capacitor being selectively charged by said charging current from said secondary winding to establish a resonating voltage on said capacitor, said resonating voltage being applied back through said transformer so that said switch means couples said voltage source to said primary winding at zero current conditions across said switch means;
- (e) a load; and
- (f) means coupled between said capacitor and said load for rectifying and applying said voltage stored on said capacitor to said load.

2. The quasi-resonant converter as claimed in claim 1, wherein said switch comprises a uni-polar transistor.

3. The quasi-resonant converter as claimed in claim 1, wherein said switch comprises a FET and a diode coupled in series with said FET.

4. The quasi-resonant converter as claimed in claim 1, wherein said switch is actuated to a first state to apply current in a first direction from said voltage source to said primary winding and to block the current flow in a

second, opposite direction, and de-actuated to a second state to apply current in said second direction from said primary winding to said voltage source, and for blocking the flow of current in said first direction, whereby said quasi-resonant converter is operative in a full-wave mode.

5. The quasi-resonant converter as claimed in claim 4, wherein said switch comprises a semiconductor switching device actuable to apply current in said first direction, and a diode coupled in parallel with said semiconductor device to apply current in said second direction.

6. The quasi-resonant converter as claimed in claim 1, wherein said capacitor is coupled in series between said secondary winding and said rectifying means to form a series resonant circuit with said characteristic leakage inductance.

7. The quasi-resonant converter as claimed in claim 6, wherein said load has a resistive component and is characterized as a voltage load.

8. The quasi-resonant converter as claimed in claim 7, wherein said voltage load comprises an output capacitor coupled to said rectifying means and in parallel with said resistive component.

9. The quasi-resonant converter as claimed in claim 1, wherein said capacitor is coupled in parallel with said secondary winding to form a parallel resonant circuit with said characteristic leakage inductance.

10. The quasi-resonant converter as claimed in claim 9, wherein said load exhibits a resistive component and is characterized as a current load.

11. The quasi-resonant converter as claimed in claim 10, wherein said current load comprises an output inductor coupled in series between said rectifying means and an output capacitor, said output capacitor being coupled in parallel to said resistive component.

12. The quasi-resonant converter as claimed in claim 1, wherein said capacitor is directly connected to said secondary winding and to said rectifying means so as to permit said capacitor to charge to both negative and positive going voltages, whereby said transformer is magnetically reset.

13. The quasi-resonant converter as claimed in claim 1, wherein said switch means operates periodically at a switching frequency F_s , said capacitor and said characteristic leakage inductance having values such that the resonant frequency of said resonant circuit is greater than F_s .

14. The quasi-resonant converter of claim 1, wherein said resonant switch means is bidirectional for periodic actuation and deactuation, and said capacitor exhibiting said characteristic capacitance and directly coupled to said secondary winding to form with said characteristic leakage inductance said resonant circuit, said switch being actuated to a first state to permit a current flow in a first direction from said voltage source to said load via said transformer and to block a current flow in a second, opposite direction, and being actuated to a second state to permit a current flow in said second direction from said load to said voltage source via said transformer and to block the current flow in said first direction for operating said quasi-resonant converter in a full-wave mode, said switch means being actuated to its first state to couple said resonant capacitor and said resonant inductor to form a resonant circuit, and to apply a charging current from said voltage source to said resonant capacitor, said resonant capacitor and said resonant inductor having respective selected impedances to establish a resonating current waveform on said resonant inductor, said resonating current waveform being applied to ensure that said switch is actuated and deactuated under zero current conditions.

* * * * *

40

45

50

55

60

65