

**TECHNOLOGICAL CONSTRUCTION AS IDENTITY FORMATION:
THE HIGH SPEED RAIL, HYBRID CULTURE AND ENGINEERING/POLITICAL
SUBJECTIVITY IN TAIWAN**

Kuo-Hui Chang

Dissertation submitted to the faculty of the
Virginia Polytechnic Institute and State University
in partial fulfillment of the requirements for the degree of

Doctor of Philosophy
In
Science and Technology Studies

Gary Lee Downey
(Chair)

Chyuan-Yuan Wu
Daniel Breslau
Saul Halfon
Matthew Wisnioski

May 24, 2010
Blacksburg, Virginia

Keywords: high speed rail, technology policy, sociology of technology, national identity,
engineering culture

Copyright 2010, Kuo-Hui Chang

**TECHNOLOGICAL CONSTRUCTION AS IDENTITY FORMATION:
THE HIGH SPEED RAIL, HYBRID CULTURE AND ENGINEERING/POLITICAL
SUBJECTIVITY IN TAIWAN**

Kuo-Hui Chang

ABSTRACT

This project examines the construction of the Taiwan high-speed rail (THSR; 台灣高鐵) technology as a vehicle of Taiwanese identity formation. The THSR project is a product of a hybridization of design from Japan and Europe. The Japanese and Europeans transferred their HSR technology to Taiwan, but Taiwanese policy actors and engineers localized and assimilated it to their politics, society and history. They reconstructed the meanings of HSR technology in an indigenized (Ben-Tu-Hua; 本土化) and democratic way. In addition to focusing on the THSR's technological content and engineering practice, this dissertation explores how Taiwan identity formation has shaped technology and vice versa. The identity formation and technological construction in Taiwan tell one techno-political story.

Since the 1960s and 1970s, Taiwanese engineers were forced by international politics to cannibalize technological projects, but later they began to localize and hybridize different foreign engineering skills and knowledge. This growing engineering culture of hybridity generated impacts on the development of Taiwan's identity politics. Some critical political leaders exploited their engineers' capability to hybridize to introduce international power into Taiwan. This power then was used to either strengthen the Taiwanese population's Chinese identity or to build their Taiwanese identity. Both politics and technology offered each other restrains and opportunities.

This project offers an approach from science and technology studies to understand postcolonial technopolitics. The engineering practice of hybridity in Taiwan has become a locally transformed knowledge to reframe and negotiate with the more advanced technologies from the West and Japan, even though it was a contingent outcome of earlier international politics. In addition to technological non-dependence, this engineering culture of hybridity has given the Taiwanese an independent political vision not only against China but the West and Japan. However, Taiwan paid significant prices to acquire technological non-dependence and international independence. In addition to extra wasted money and time, some over design was often seen in their public projects. Large technological projects also often draw political patronage. Moreover, techno-political survival alone might not be enough to represent postcolonial resistance.

ACKNOWLEDGMENT

My dissertation project was not much different from others in terms of struggles and challenges, but I had a great committee to help me out. I need especially to thank my advisor, Gary Lee Downey, for his insightful advice, relentless encouragement and thoughtful concerns about my research project and career during the year when I was conducting research and writing dissertation in Taiwan. I am also impressed by his energy and passion in academia. He has showed highly respectful scholarship that I hope to reach in the future.

I would also like to thank professor Chyuan-yuan Wu of National Tsing Hua University in Taiwan. He not only generously shared his insights and thoughts with me but sharply challenged my ideas with his knee observation and study on the relationship of Taiwan identity and technology. Saul Halfon was always my first option to consult with the topics of technopolitics, postcolonialism, discourse analysis and policy studies. I and my project have greatly benefited from his courses and advice. Daniel Breslau helped me a lot to conceptualize my research proposal and advised on me subtle but very significant issues in my dissertation. Matthew Wisnioski gave me very thorough comments and constructive suggestion. In addition to knowledge of history of technology, I learned critical points of how to structure and arrange materials in the dissertation from him.

Matthew Goodrum has been the most incredible friend. He was so knowledgeable, intellectual and fun to be with during the years I was in the United States. I must acknowledge the huge debt that I owe to him. He has converted my life philosophies in many ways and I really appreciate this. I want to thank Pei-Fang Jennifer Tsai and Fangyee Lin for their relentless encouragement and friendship. I also want to thank Ashley Shew who has been the most supportive and thoughtful friend and colleague to me. Sungwoo Ahn was always the friend I could freely share thoughts and life with. I am so glad that I could make such important friends in Blacksburg.

I would particularly like to thank Richard Burian who always gave me words of support and showed great sympathy. I also want to thank Jongmin Lee, Sonja Schmid, Ann Laberge, Yu-Hsiu Hung, Jin You, Tristan Lloyd, Chris Hays, Robert Davis, Robert Olivo and Barbara Reeves for their constant friendship and conversation. I need to thank Crystal Harrell and Karen Snider for their help during my study.

Outside of Blacksburg, I would like to thank the Taiwan Ministry of Education for their generous scholarship and the Academia Sinica for their great predoctoral fellowship. My interviewees from the THSRC, BOHSR, CECI and Taiwan Railways etc. were also the people who made key contributions to my project that I have to thank particularly. I would also like to thank my friends in Taiwan: LB, Mei-Chen Melissa Lin, Jei-Yu Alice Lin, Kun-Yu Liu, Kun-Chang Liu, Yu-Zen Lee, Hsi-Yuan Chen, Li-Wei Chen, Yen-Tsen Eugene Lin and Su-Chuan Lee for their friendship and great sympathy.

Lastly and the most importantly, I want to thank my family—to my parents, brothers' and sister for their constant support and love.

TABLE OF CONTENTS

CHAPTER 1 INTRODUCTION	1
1.1 Background: Technology and Identity Formation in Taiwan	3
1.2 Relationship of the THSR to Taiwan Identity	7
1.3 Literature Review	15
1.3.1 Literature on the THSR.....	16
1.3.2 Literature on HSR.....	18
1.3.3 STS Literature on Identity Shaping.....	21
1.4 Research Methods	26
1.4.1 Primary Source Collecting.....	27
1.4.2 Field Research Strategies.....	31
CHAPTER 2 TAIWAN RAILWAYS, INTERNATIONAL POLITICS AND ENGINEERING LABOR UNTIL 1973	35
2.1 Historical Background of Taiwan Railways Engineering: Engineering Practice with Little Local Participation	35
2.2 Emerging Local Engineering Involvement Surrounded by Foreign Power	38
2.2.1 Early Cannibalization as a Way of Surviving under a Difficult Economy and Distorted International Politics.....	39
2.2.2 Early Railway Cannibalization Emerged and Spread to the Super Railway Project.....	47
2.3 Engineering Socialization of Early Cannibalization	50
CHAPTER 3 TAIWAN HSR PROJECT'S ENGINEERING AND CONSTRUCTION PLANNING: CANNIBALIZATION, INTERNATIONAL COLLABORATION AND DESIGNING FOR INCLUSION	52
3.1 From Early Cannibalization Experience to Collaborative Engineering Policy	53
3.1.1 Leveling Cannibalization Experience Up to International Collaboration Policy ...	56
3.1.2 Merging Early Cannibalization Experience with International Collaboration Policy.....	63
3.2 Early Engineering Culture of Hybridity: Designing for Inclusion	68
3.3 Engineering Experience and Policy of Hybridity Emerged	79
3.3.1 Engineering Planning of Hybridity: National Differences Count.....	80
3.3.2 Engineering Thinking of Hybridity Flowed into the BOT Model.....	82
CHAPTER 4 DEMOCRATIZED AND INDIGENIZED STATE TRANSFORMATION SHAPED THE TAIWAN HSR PROJECT	87
4.1 Authoritative State, Emerging Taiwanese Identity and the HSR Policy in the 1980s and Early 1990s	87
4.1.1 Fading Strongman Politics, National/His Development Projects, and the Taiwan HSR Abandoned in the 1980s.....	87
4.1.2 Emerging Democratic Politics, Living Community, and the Taiwan HSR Needed in the Early 1990s.....	99
4.1.3 Actual State Politics on the Taiwan HSR Privatization Policy, 1991~1994.....	104

4.2 Hybrid Identification Became Taiwanese Identification: From Dominance to Indigenization to Subjectivization	108
4.2.1 Activating the Taiwanese People, Discourse/Identity Making, and How the Taiwan HSR Came to be Desired in the Middle 1990s	110
4.2.2 Taiwanese/Chinese Actors Struggled over the Taiwan HSR Project	115
4.2.3 Privatization Policy: An Outcome of Gaps between Core Discourse Design and Local Actors' Practices	121
CHAPTER 5 LOCALIZED AND INHERITED ENGINEERING PRACTICE OF HYBRIDITY: THSR SPECIFICATION MAKING, CONSTRUCTION PLAN AND CIVIL CONSTRUCTION	125
5.1 Hybrid Strategies for Engineering Specification and Construction Plan Making .	126
5.1.1 How Hybrid Thinking about Engineering Specification Making Passed from the BOHSR to the THSRC	127
5.1.2 THSRC's Hybrid Engineering Specification Making and Construction Plan.....	129
5.2 Localized and Inherited Engineering Practice of Hybridity: Civil Design and Construction	132
5.2.1 THSRC Inherited the POHSR/BOHSR's Localized Civil Engineering Thinking	132
5.2.2 Engineering Inclusiveness Comprised of Local Civil Design Thinking	135
5.2.3 Engineering Inclusiveness Brought Engineering Creativity and Hybridization....	141
5.2.4 Subcontractor Collaboration	149
5.3 Impacts of International Collaboration on Taiwan's Engineering Culture of Hybridity	155
CHAPTER 6 EVOLVED TAIWANESE ENGINEERING HYBRIDITY: OPTIMIZATION, MEDIATION AND NON-DEPENDENCE	160
6.1 Optimization: Mixing Different Track Designs	161
6.1.1 Hybrid Specification Making.....	162
6.1.2 Pursuing Efficiency by Installing Different Types of Rail Beds	165
6.2 Managing for Mediation	173
6.2.1 Struggles of Integrating the Shinkansen Core system into European HSR Civil Design	174
6.2.2 Hybrid Engineering Struggles: Japanese Records v.s. European Simulation.....	177
6.2.3 Hybrid Engineering Struggles: Trust v.s. Cybernetics	181
6.2.4 Hybrid Engineering Struggles: Specific v.s. Diverse Experiences.....	182
6.3 Pursuing Non-dependent Maintenance	184
6.4 Engineering Hybridizer or Butcher?: Challenges, Risks and Cost	188
6.5 Best Mix or Localized Hybrid?	197
CHAPTER 7 TAIWAN HSR PROJECT FACILITATED THE TAIWANESE/CHINESE IDENTITY DISCOURSES COMPETITION: POLITICAL/ENGINEERING DEPENDENCE, COMPETITION AND SUBJECTIVITY	200
7.1 THSR Project Politically Internationalizing and Position Taiwan (HSR)	201
7.2 BOT Contract Competition, THSRC Core System Switch Controversy, and Implicit Discourse Politics	206

7.3 The THSR Project Fading into Domestic Party Politics	217
CHAPTER 8 CONCLUSION: SUBJECTIVITIZING ENGINEERING/POLITICAL IDENTITY	226
8.1 Co-producing Dependent/Subjective Engineering/Political Identity	227
8.2 Opening the Black Box Is Not Equal to Reproduction	229
8.3 When the THSR Hits a Speed Bump	232
BIBLIOGRAPHY	234
APPENDIX: INTERVIEW LIST	277

TABLE OF FIGURES

FIGURE 2. 1 TAIWAN RAILWAYS IN 1930 (WEST TRUNK LINE: KEELUNG—KAOHSIUNG)	37
FIGURE 2. 2 ALTERNATED HITACHI DIESEL-ELECTRIC LOCOMOTIVE	44
FIGURE 2. 3 ORIGINAL HITACHI DIESEL-ELECTRIC LOCOMOTIVE	44
FIGURE 3. 1 TAIWAN HSR PLANNING MANAGEMENT FRAMEWORK IN WT-HSR-GP	69
FIGURE 3. 2 HSR SUBSYSTEM RELATIONSHIPS	73
FIGURE 3. 3 TYPICAL SECTION HSR RIVER BRIDGE (WT-HSR-FS)	77
FIGURE 3. 4 TYPICAL SECTION HSR VIADUCT BRIDGE (WT-HSR-FS)	77
FIGURE 3. 5 HSR AERIAL STRUCTURE TYPES (WT-HSR-GP)	78
FIGURE 3. 6 TYPICAL SECTION OF FRENCH TGV AERIAL STRUCTURE (WT-HSR-GP)	78
FIGURE 5. 1 THSRC CIVIL DESIGN REVIEW PROCESS	131
FIGURE 5. 2 WT-HSR-GP TUNNEL DESIGN	142
FIGURE 5. 3 SHINKANSEN (TŌKAIDŌ AND SANYŌ LINES) TUNNEL DESIGN	142
FIGURE 5. 4 TGV (ATLANTIC LINE) VOUVRAY TUNNEL DESIGN	143
FIGURE 5. 5 ICE (MANNHEIM—STUTTGART) TUNNEL DESIGN	143
FIGURE 5. 6 THSR TUNNEL DESIGN	144
FIGURE 5. 7 MICRO PRESSURE WAVE PHENOMENON	145
FIGURE 5. 8 CORRELATED RELATIONS OF TUNNEL AIR PRESSURE AND TUNNEL SECTION SIZE ..	146
FIGURE 5. 9 THSR TUNNEL ENTRANCE/EXIT	147
FIGURE 5. 10 SHINKANSEN 700S ROLLING STOCK	148
FIGURE 5. 11 THSR 700T ROLLING STOCK	148
FIGURE 5. 12 THSR VIADUCT BRIDGE	150
FIGURE 5. 13 THSR VIADUCT DESIGN	151
FIGURE 5. 14 ROUND BRIDGE BEAM PILLARS	152
FIGURE 5. 15 LAUNCHING TROLLEY	154
FIGURE 5. 16 LAUNCHING GANTRY 1	154
FIGURE 5. 17 LAUNCHING GANTRY 2	154
FIGURE 5. 18 VIADUCT SHEAR BEARING	154
FIGURE 6. 1 JIS-60 TYPICAL SECTION	165

FIGURE 6. 2 UIC-60 TYPICAL SECTION.....	165
FIGURE 6. 3 J-SLAB RAIL BED	166
FIGURE 6. 4 J-SLAB STRUCTURE	166
FIGURE 6. 5 RHEDA 2000 RAIL BED.....	167
FIGURE 6. 6 RHEDA 2000 STRUCTURE	167
FIGURE 6. 7 LOW VIBRATION RAIL BED	169
FIGURE 6. 8 LOW VIBRATION STRUCTURE	169
FIGURE 6. 9 EMBEDDED RAIL STRUCTURE.....	170
FIGURE 6. 10 THSR BALLAST RAIL BED	170
FIGURE 6. 11 THSR 700T ROLLING STOCK FORMATION.....	176
FIGURE 6. 12 RELATIONS OF CICE, ICE/ISE AND IV&V IN THSR PROJECT.....	193

TABLE OF CHARTS

CHART 1. 1 THE IMPORTANT HISTORICAL EVENTS OF THE THSR PROJECT AND ITS POLITICAL BACKGROUND	12
CHART 4. 1 TAIWAN ECONOMIC GROWTH RATE, 1951~2010	98
CHART 4. 2 CHANGES IN THE TAIWANESE/CHINESE IDENTITY OF TAIWANESE AS TRACKED IN SURVEYS BY THE ELECTION STUDY CENTER, NATIONAL CHENGCHI UNIVERSITY (1992~2009.06).....	114
CHART 7.1 CHINA DEVELOPMENT AND THSRC FINANCIAL INVESTMENT PROPOSAL (BILLIONS NTD).....	212
CHART 7.2 THSRC DAILY PASSENGER NUMBER FORECAST	225

TABLE OF TABLES

TABLE 3. 1 PROFESSIONAL STAFF DISTRIBUTION OF THE WT-HSR-FS TEAM	58
TABLE 4. 1 TAIWAN DOMESTIC INVESTMENT GROSS.....	90
TABLE 4. 2 U.S. CAPITAL ASSISTANCE OBLIGATIONS AND NET DOMESTIC INVESTMENT BY MAJOR SECTIONS, 1951~63 (IN U.S. DOLLAR EQUIVALENTS)	94
TABLE 4. 3 TEN MAJOR CONSTRUCTION, 12 NEW PROJECTS AND 14 MAJOR PLANS	97
TABLE 5. 1 CIVIL ENGINEERING SPECIFICATIONS OF WT-HSR-FS, WT-HSR-GP, AND SHINKANSEN, TGV AND ICE BEFORE 1991, AND THSR IN 2007.....	139
TABLE 6. 1 TRACK AND ROLLING STOCK ENGINEERING SPECIFICATIONS OF WT-HSR-FS, WT-HSR-GP, AND SHINKANSEN, TGV AND ICE BEFORE 1991, AND THSR IN 2007	163
TABLE 7.1 THSRC EQUITY DISTRIBUTION.....	223

TABLE OF ACRONYMS

6-Year Plan	Six-Year National Development Plan (六年國家建設計畫)
12 New Projects	Twelve New Development Projects (十二大建設)
12 Plans	Twelve Major Construction Plans (十二項計畫)
14 Major Plans	Fourteen Major Infrastructure Plans (十四大建設)
ATC	Auto Train Control
AVE	Alta Velocidad Espanola (Spanish High Speed Rail)
BOHSR	Bureau of High Speed Rail, Ministry of Transportation and Communications (交通部高速鐵路工程局)
BOT	Build-Operate-Transfer
CAD/CAM	Computer-Aided-Design/Computer-Aided-Manufacturing
CECI	China Engineering Consultants Incorporated or CECI Engineering Consultants, Inc. (中華顧問工程司/世曦工程顧問公司)
Central JR	Central Japanese Railway Company
China Development	China Development Consortium/Corporation (中華開發)
CHSRC	China High Speed Rail Consortium (中華高速鐵路聯盟)
CICE	Independence Checking Engineer
CSF	China Steel Factory
CTC	Central Train Control
DEC	Deutsche Eisenbahn-Consulting GmbH
DPP	Democratic Progress Party (民主進步黨)
Economic Council	Council for Economic Planning and Development, Executive Yuan (行政院經濟建設委員會)
Employer's Requirement	Employer's Functional and Technical Requirements
EMU	Electrical Multiple Units
GM	General Motors
GRB	Government Research Bulletin
HFA	Halcrow Fox and Associates
Hong Kong Transit	Hong Kong Mass Transit Railway Corporation
HSR	High Speed Rail
HST	High Speed Train
ICE	InterCityExpress (German High Speed Rail) or Independence Checking Engineer
ISE	Independent Site Engineer
IV&V	Independent Validation and Verification
JIS	Japanese Industrial Standards
J-Slab	Japanese Slab Track
JNR	Japanese National Railway
JR-W	West Japanese Railway Company
KMT	Kuomintang (the Chinese Nationalist Party; 中國國民黨)
KTX	Korea Train Express (Korean High Speed Rail)
Lloyd's Register	British Lloyd's Register of Shipping
Low Vibration	Low Vibration Track
MCE	Memorandum of Contract Execution

MIRG	Memorandum of Items Responsible by the Government
MOTC	Ministry of Transportation and Communications (交通部)
Mutual Security	Mutual Security Mission to China
NEAR	Navigating Electronic Agencies' Records
North Link	North Link Line (北迴鐵路)
OPEN	Official Publication Echo Network
PBI	Parsons Brinckerhoff International, Inc.
POHSR	Preparatory Office of Bureau of High Speed Rail, Ministry of Transportation and Communications (交通部高速鐵路工程局籌備處)
PP	Pull and Push
Provincial Government	Taiwan Provincial Government (台灣省政府)
PSS	Postcolonial Science Studies
RAMS	Reliability, Availability, Maintainability and Safety
Railway Reconstruction	Railway Reconstruction Bureau, Ministry of Transportation and Communications (交通部鐵路改建工程局)
RE	Resident Engineer
RESOT	Rail Engineering Society of Taiwan (台灣鐵路工程學會)
Rheda	German Rheda 2000 Track
RTRI	Railway Technical Research Institute, Japanese National Railway
SNCF	Société nationale des chemins de fer français (the French National Railways)
South Link	South Link Line (南迴鐵路)
STS	Science and Technology Studies
Super Railway	Super Railway Project (超級鐵路)
Super Railway Research	Research Project on the Development of Constructing Super Railway (發展建設超級鐵路研究計畫)
Taiwan Power	Taiwan Power Company (台灣電力公司)
Taiwan Railways	Taiwan Railways Administration (交通部台灣鐵路管理局)
Taiwan Shinkansen	Japanese Taiwan Shinkansen Corporation (Taiwan Shinkansen Consortium; 台灣新幹線公司/聯盟)
Ten Construction Plan	Ten Major Construction Plan (十大建設)
TGV	Train à grande vitesse (French High Speed Rail)
THSR	Taiwan High Speed Rail (台灣高鐵)
THSRC	Taiwan High Speed Rail Company/Corporation/Consortium (台灣高鐵公司/企業/聯盟)
UIC	Union Internationale des Chemins de Fer (International Union of Railways)
West Trunk	West Trunk Line (台鐵縱貫線/西部幹線)
WT-HSR-FS	West Taiwan High Speed Rail Feasibility Study (台灣西部走廊高速鐵路可行性研究)
WT-HSR-GP	West Taiwan High Speed Rail General Planning Study (台灣西部走廊高速鐵路綜合規劃)

CHAPTER 1

INTRODUCTION

This project examines the construction of the Taiwan high-speed rail (THSR; 台灣高鐵) technology as a vehicle of Taiwanese identity formation. The THSR project is a product of a hybridization of design from Japan and Europe. The Japanese and Europeans transferred their high-speed rail (HSR) technology to Taiwan, but Taiwanese policy actors and engineers localized and assimilated it to their politics, society and history. They not only have built the physical facilities of the HSR technology on the island, but also have reconstructed its meanings in an indigenized (Ben-Tu-Hua; 本土化) and democratic way.

After ten years of success of Japan's first HSR, Shinkansen (新幹線), the Taiwan Provincial Government (Provincial Government; 台灣省政府) permitted its Taiwan Railways Administration (Taiwan Railways; 交通部台灣鐵路管理局) in 1974 to conduct HSR research for the twenty-year-later transportation on the west Taiwan corridor. Eight years later, Taiwan Railways later submitted several reports to the Provincial Government and its central government, which is officially named the Republic of China. However, it turned out that a local private company called the THSR Corporation (THSRC; 台灣高鐵公司) finally completed the construction of the HSR in 2007. This thirty-four-year period from 1974 to 2007 approximately overlapped with a time when the people on the island of Taiwan experienced a series of changes brought about by democratization, indigenization and rapid economic growth.

Taiwan's engineering practice of hybridity was co-produced with and forced by its international political power and domestic societal changes. Since the 1950s, some advanced countries from the west and Japan used their political, technological and military forces to influence the government on the island of Taiwan. Among others, they exploited Taiwan by partitioning its infrastructure projects into several subsystems, such as Taiwan Railways'

locomotives and electrification projects in the 1960s and 1970s. However, Taiwanese engineers also learned different engineering knowledge and practice through international collaboration. They began by cannibalization, then they evolved to integrate foreign subsystems and hybridize different skills and even to create a localized engineering practice special to Taiwan. This engineering practice evolved over time along with Taiwan's societal changes. Unlike the Taiwan Railways engineers who were forced to accept engineering practices from different countries, the THSRC engineers have been actively pursuing engineering optimization by introducing different practices to the THSR project. This THSR case study demonstrates how the Taiwanese engineers have inherited and recreated their traditional engineering thinking and hybrid practices to redesign the transferred technologies to the point where the original maker could no longer recognize their technology.

The engineering practice that values hybridity has not only reflected those political threat and societal changes but even forged them into a broader and deeper integrated phenomenon in terms of identity formation. In addition to convincing advanced countries to export their technology, by using some significant infrastructure projects such as the THSR, the Taiwanese political leaders in the 1990s reflexively exploited their engineers' capabilities to hybridize to include more international political interests that they hoped to acquire. The more different foreign technological participation was introduced to Taiwan the more international political power would help them strengthen or build Chinese/Taiwanese identity discourses. Both the engineering and political evolutions manifested in the THSR project share a conceptual trajectory from Taiwan's technological and political dependence on foreign power to its competition with them to its struggles for subjectivity (主體性).¹ Taiwan's long history of

¹ I use the word subjectivity in this project mainly because Lee has widely advocated it since the mid 1990s. Moreover, it has become a popular political term accepted by Taiwanese society. The word subjectivity especially addresses that the name of Taiwan or Taiwanese should be separated from and placed prior to China, Chinese, or even the Republic of China in any identity issues and even public policies. While political sociologist Hsin-huang Michael Hsiao of Academia Sinica interprets Taiwan subjectivity as Taiwan consciousness and Taiwan nation-

discursively/consciously pursuing independent politics shaped itself into an engineering culture that values hybridity. The THSR engineering policy and practice of hybridity reflexively played an inalienable and active role in competing discourses about the identity of Taiwan. Taiwan's engineering culture has a larger significance in the sense that it has constructed Taiwan's culture along with Japanese culture, Western culture and other cultures.

1.1 Background: Technology and Identity Formation in Taiwan

The question of a sense of community in Taiwan has existed for at least four centuries. The Ming court (明朝) was forced by the Qing court (清朝) to defeat the Dutch and rebuild itself in Taiwan after its expulsion from China in 1662. The Qing court replaced the Ming court's rule in Taiwan in 1683. In 1895, the Qing court of China ceded the island of Taiwan to Japan after the Sino-Japanese War (甲午戰爭) of 1894~1895. The Japanese colonized Taiwan for fifty years until the end of the Second World War. When Japan surrendered to the Allies in 1945, Taiwan became a part of the Republic of China's territory even though it never ruled Taiwan since its establishment in 1912. The Chinese, Japanese, Taiwanese, and even the mix of the above are all possible forms of community among and within the Taiwanese generations. Currently, the Taiwanese separate themselves into three community identities: the Taiwanese, the Chinese, and a mixture of both Taiwanese and Chinese.²

building consciousness, political scientist Dan Lynch of the University of Southern California uses this phrase to refer to the movement to replace Chinese identity with a Taiwan-centered identity. However, Taiwan subjectivity does not completely exclude the idea of the existence of Chinese identity and its relevancies. Although the largest group of the population (52.1%) in Taiwan currently identify themselves as Taiwanese only, the second largest group claims they are both Taiwanese and Chinese (39.2%). To the second largest group, the Chinese identity is still a part of their identity but their Taiwanese identity, to a certain degree, is prior to the Chinese identity. See Chart 4.2. See more discussion on Taiwan subjectivity in chapters 4 and 7. See Hsin-huang Michael Hsiao, "Recapturing Taiwan's Democratization Experience," keynote speech in the First Biennial Conference of World Forum for Democratization in Asia, Sep. 15~17, 2005. Daniel C. Lynch, *Rising China and Asian Democratization: Socialization to "Global Cultures" in the Political Transformations of Thailand, China, and Taiwan* (Stanford, CA: Stanford University Press, 2006). Daniel C. Lynch, "Refocusing the Taiwan Nationalists' Subjectivity Movement," in the Jamestown Foundation China Brief, 4 January 2005. Shelley Rigger, "Party Politics and Taiwan's External Relations," *Orbis* 49 (2005): 413~28. Bi-yu Chang, "From Taiwanisation to De-sinification: Culture Construction in Taiwan since the 1990s," *China Perspective* 56, 3 (2004).

² According to the data of "Taiwanese/Chinese Identification Trend Distribution in Taiwan, 2009" from the Election Study Center at National Chengchi University, 52.1% (17.3% in 1992) of the Taiwanese identify themselves with the

This project explores the issue of Taiwanese identity formation, but it is approached from the perspective of the history and political sociology of technology, which is different from other studies based on political science, culture studies or political sociology.³ This project examines how the development of technology has helped to formulate the Taiwanese people, discourse and community, and distinguish them from others. Contemporary Taiwanese identity formation since the late Japanese colonial period has been a technological phenomenon.

The relationship between technology and a sense of identity in Taiwan are historically intertwined, but they are not revealed systematically yet. This project offers a descriptive hypothesis on the interactive history of technology and a sense of identity in Taiwan. Although this project mainly concentrates on engineering culture and practice in the THSR project and how it represents and facilitates contemporary Taiwanese identity formation, it reflects and examines the historical relationship between technology and a sense of identity in Taiwan.

Basically, the interactive history of technology and a sense of identity has evolved over time since the late Japanese colonial period of the 1930s. The point of departure is to examine what Japanese colonial politics from 1895 to 1945 means to the Taiwanese. Instead of the

Taiwanese, 4.3% (26.2% in 1992) with the Chinese, and 39.2% (45.4% in 1992) with both the Taiwanese and Chinese. Also see Chart 4.2. See more detail identity discussion in chapters 4 and 7.

³ See footnote 1. Also see Chi Su, *Taiwan's Relations with Mainland China: a Tail Wagging Two Dogs* (NY: Routledge, 2009). Christopher Hughes, *Taiwan and Chinese Nationalism: National Identity and Status in International Society* (NY: Routledge, 1997). J. Bruce Jacobs, "Taiwanese and the Chinese Nationalists, 1937-1945: The Origins of Taiwan's Half-Mountain People (Banshan Ren)," *Modern China* 16, 1 (1990): 84-118. Mau-Kuei Chang, "Taiwan's Nationalistic Politics and Its Difficult 'Status Quo'," *The Copenhagen Journal of Asian Studies* 21 (2005): 91-124. Chengqiu Wu, "The Discursive Construction of Taiwanese National Identity" (PhD diss., Virginia Polytechnic Institute and State University, 2007). Shale Horowitz, Uk Heo, and Alexander C. Tan, ed., *Identity and Change in East Asian Conflicts: the Cases of China, Taiwan, and the Koreas* (NY: Palgrave Macmillan, 2007). Sechin Y.S. Chien and John Fitzgerald, ed., *The Dignity of Nations: Equality, Competition, and Honour in East Asian Nationalism* (Hong Kong: Hong Kong University Press, 2006). Susan J. Henders, ed., *Democratization and Identity: Regimes and Ethnicity in East and Southeast Asia* (Lanham, MD: Lexington Books, 2004). Leszek Buszynski, *Asia Pacific Security: Values and Identity* (NY: Routledge, 2004). William A. Callahan, *Contingent States: Greater China and Transnational Relations* (Minneapolis, MN: University of Minnesota Press, 2004). Chengqiu Wu, "Peace or War in the Taiwan Strait: a Game Theoretical Analysis of the Taiwan Issue" (Master thesis, Virginia Polytechnic Institute and State University, 2003). Stéphane Corcuff, ed., *Memories of the Future: National Identity Issues and the Search for a New Taiwan* (Armonk, NY: M. E. Sharpe, 2002). Xiaobing Tang, "On the Concept of Taiwan Literature," *Modern China* 25, 4 (1999): 379-422. Shelley Rigge, "Social Science and National Identity: A Critique," *Pacific Affairs* 72, 4 (1999): 537-52.

Japanese, some research has positioned the Taiwanese in the center of the colonial politics during the Japanese occupation period. This perspective not only shows how the Taiwanese confronted Japanese political domination, but also how they conceived the modernity that the Japanese brought in Taiwan. Some studies have shown how the Taiwanese positioned themselves in this conflict situation at the time, because they simultaneously resisted and accepted Japanese colonization.⁴ Based on this insight of understanding colonial history from the perspective of the colonized, one important point might be worth delving into. That is, while some Taiwanese relentlessly showed their resistance and rebellion to the Japanese, some also started thinking of and working on how to use Japanese technologies to acquire their interests regarding modernity.⁵ By this perspective, the history of technology in Taiwan would be one of the critical aspects of its colonial history, because technological construction and mentality had comprised of some Taiwanese interests. It has been argued that, until now, some of the senior Taiwanese still cherish the memory of the Japanese occupation. Technology might have played an important role between the Taiwanese and Japanese in this phenomenon; however, this has not been researched yet.

To be more specific, how did some of the Taiwanese identify with the Japanese through technologies in the late colonial period? Through the manufacturing establishment created for export to their new homeland in Japan, modern technological production had become one of the sources that shaped the colonized Taiwanese sense of community. This is because manufacturing for export to Japan, on the one hand, turned out to be a kind of domestic exchange

⁴ See Chen Fang-Ming (陳芳明), *Colonial Modernity: Historical and Literary Perspectives on Taiwan* (Taipei: Rye Field Publications, 2004). *Postcolonial Taiwan: Essays on Taiwanese Literary History and Beyond* (Taipei: Rye Field Publications, 2002). Ming-Cheng M. Lo, *Doctors within Borders: Profession, Ethnicity, and Modernity in Colonial Taiwan* (Berkeley, CA: University of California Press, 2002). Kuei-Fan Chou (邱貴芬), "The Japanese Memory and New Historical Imagination in Taiwan," in *Reviewer Thirty: the Selections of the Taiwanese Literature in the Thirtieth Year 1978-2008*, ed. Ray-Tan Lee (Taipei: Chiuko Publication, 2008), 360~89.

⁵ See Shiao-chian Su, (蘇曉倩) "Body and Education: Body Discipline in Vocational School in Taiwan under Japanese Colonial Rule, 1919-1945," (Master thesis, National Chi Nan University, 2003), especially chapter 3.

rather than international trade, which represented an emergence of a discursive self-consciousness.⁶ Bao-Lin Wang, a graduate of electrical engineering from the Taipei State Industrial School during the colonial period, said “I believe that we technologists’ mission is to promote the development of Japanese industry and this is the only way for us to repay our royal home country Japan.”⁷ On the other hand, the mentality of technology gradually made some Taiwanese want to break the connection of a traditional Chineseness in the process of colonization. Technological construction of colonization, thus, became one important source for some Taiwanese to connect themselves with the Japanese.⁸

Secondly, following the above conceptualization, this project also locates the Taiwanese in the historical center during the KMT (Kuomintang, the Chinese Nationalist Party; 中國國民黨) period of governance/colonization.⁹ In 1949 the authority/colonizer in Taiwan shifted from the Japanese to an alliance of Americans and those Chinese mainlanders who fled the mainland due to the Chinese civil war. The KMT government, with the official name of the Republic of China, retreated to Taipei and added around two million people from China to Taiwan’s population of eight million.¹⁰

⁶ Actually, the technological construction of colonization also became one important source for some Taiwanese to identify themselves *against* the Japanese, especially when technology worked with the Japanese colonial policy to exploit the Taiwanese. Some colonial literary texts, such as Her-Ro Lu’s (呂赫若) “Cow Trailer (牛車)” and Shin-Long Wu’s (吳新榮) “Chimney (煙囪),” have shown how technology destroyed Taiwanese traditional life.

⁷ Bao-Lin Wang (王寶林), “Our Mission (我等の任務),” in *Alumni Magazine the Taipei State Industrial School Alumni Association* 18 (1939): 156~7.

⁸ For example, in Wen-Huan Chang’s (張文環) “Capon” (閩雞) and Ying-Tsung Long’s (龍瑛宗) “A Small Town Planted with Papaya Trees” (植有木瓜樹的小鎮), some Taiwanese strongly showed their interests in the Japanese technological life style.

⁹ The conceptual idea of whether the KMT government was a re-colonizer has been a controversial issue and raised much debate in Taiwan. Fang-Ming Chen and Chen-Hui Lu (呂正惠), among others, have argued about this idea seriously and no reconciliation has been seen. See Chen. Also see Chen-Hui Lu, *Scars of Colonies: the Problems of the Taiwanese Literature* (Taipei: Renjen Publications, 2002).

¹⁰ See Office of Taiwan Governor-General (台灣省行政長官公署) ed., *Fifty-one Years of Taiwan's Statistics (臺灣省五十一年來統計提要)* (Taipei: 1946). Data downloading at <http://twstudy.iis.sinica.edu.tw/twstatistic50/> Also see Cheng-Hsiang Chen (陳正祥) and Chi-Hsian Dwan (段紀憲), “On Taiwan’s Population,” *Quarterly Journal of Bank of Taiwan* 4 (1951): 39~41.

The Republic of China/KMT government not only brought its political scheme in terms of power institution and government structure to Taiwan but also actively constructed Taiwanese self-identity into a Chinese identity through manifold means.¹¹ These identity-shaping efforts worked well, but this Chinese identity-shaping, to some Taiwanese, might be facilitated by their manufacturing production for export to the United States (U.S.). Most of the actors in Taiwan, including the KMT technocrats, Taiwanese, Chinese and even Japanese, were integrated to work together to take economic advantages and obtain international political protection from the U.S. Manufacturing production for export to the U.S. was a common goal among most of the above actors, thus it shaped them as a people on the island of Taiwan. To some extent, part of the Chinese identity formation was strengthened by this technological production. However, as noted, there are other aspects to defining the island of Taiwan as a Chinese community. Manufacturing production for export to the U.S. is one of the defining ways.

In short, the symbiotic phenomenon of technology and sense of identity shaping each other in Taiwan has taken place since the late Japanese colonial period, but it has changed over time. During the periods of Japanese occupation and KMT governance/re-colonization, technology played a facilitating role in shaping the Japanese and Chinese identities in Taiwan.

1.2 Relationship of the THSR to Taiwan Identity

The intriguing phenomenon displayed in the THSR project is how the Taiwanese indigenized and democratized their political relations and how they appropriated and localized those imported technologies among themselves, their land and their others. Although they appeared to be separate from each other, the engineering and political relations displayed in the THSR project shared a similar conceptual trajectory from Taiwan's political and technological dependence on foreign power to its competition with them to its struggles for subjectivity from

¹¹ See more detail identity discussion and Taiwan's profile in chapters four and seven.

them. They also worked together to shape an emerging Taiwanese identity distinct from its past discursive Chinese and Japanese identities. This project intends to study how the Taiwanese mobilize their understanding of these ideas as they go about trying to build the THSR and creating a new image of what it means to be a sharing a sense of identity.

Taiwan Railways first proposed the Super Railway Project (Super Railway; 超級鐵路計畫) in 1973 and got the Provincial Government's permission to conduct relevant research in 1974;¹² however, Super Railway was ignored by and finally abandoned by the central government (officially named the Republic of China) in the 1980s.¹³ In 1987, however, the Ministry of Transportation and Communications (MOTC; 交通部) of the central government seriously began to plan a HSR policy and attempted to construct the HSR by itself. Instead of the central government, three years after it won the BOT (Build-Operate-Transfer) contract from the MOTC, it was a local private company, the THSRC, which began HSR construction in 2000.¹⁴ The THSR started its business service in January 2007. It runs approximately 335.5 kilometers (208 miles) along the west coast of Taiwan from Taipei City to Kaohsiung City (the two biggest cities

¹² See MOTC, File Number: 0671010103/0005/0001/001, Dock Number: 67123348, on Dec. 6, 1978.

¹³ When the Republic of China took over Taiwan in 1945, it established the Taiwan Provincial Government in Taipei to govern the island. However, the Republic of China government fled from China in 1949, it relocated the Provincial Government in central Taiwan. Therefore, the Republic of China government and its Provincial Government controlled almost the same territory and population until the two biggest cities of Taipei and Kaohsiung were separated from Taiwan Province in 1967 and 1979. Basically, the KMT fully controlled the above governments and cities until the 1990s. However, the central government consisted of more Chinese politicians and bureaucrats than the others. Only a few native Taiwanese were allowed to or managed to access state politics before the lifting of Martial Law in 1989. Dr. Sun Yat-Sen, who led the revolution against Qing China and built the Republic of China in 1912, designed the institutional structure of the central government of the Republic of China. Basically, the government divides its fundamental political functions into five branches and distributes them to five Yuans. Among the five Yuans, the Executive Yuan (行政院) is the main administration that covered more than 95% of the bureaucracy. Its director was the premier who supervises most of the ministries and departments in the central government, including the Ministry of Transportation and Communications. S/he and those ministers and department directors are composed the Republic of China's cabinet. The other four Yuans are the Legislative Yuan (立法院), which plays the role of congress in most democratic countries; the Judicial Yuan (司法院), which is equal to the court systems; the Control Yuan (監察院) mainly plays the role of ombudsman; and the Examination Yuan (考試院) that is arranged to recruit and maintain the bureaucratic system. See more detail at the website of the Republic of China President Office (<http://www.president.gov.tw/en/>). Chapters four and seven also introduce some ministries, department and the Executive and Legislative Yuans.

¹⁴ See Bureau of High Speed Rail (BOHSR), *Memorial Collection for the THSR Open to Traffic*, (Taipei: BOHSR, 2007).

and the eleventh busiest air route in the world in 2004).¹⁵ With trains operating at up to 300km/h, the journey time by train between the two cities was cut from 4.5 hours to roughly 90 minutes.

The Republic of China government on Taiwan claims that the THSR would create a new vision of national development and the third revolution of land transportation in Taiwan.¹⁶ After the completion of the THSR, the western Taiwan corridor has become an integrated living belt for the Taiwanese, in which they are able to make a comfortable round trip between the north and south in a day. Unlike the previous two major transportation constructions, the conventional railway system completed during the Japanese occupation and the first national highway constructed in the 1970s, the policy goal of the THSR is for the local people rather than the state. While the conventional railway and first national highway initially cooperated with promoting manufacturing production for export to Japan and the U.S., the THSR has been shaped locally and democratically to produce more social, political and economic interaction on the island of Taiwan. The THSR, as the third transportation revolution, is different from the previous two projects in that it seeks to transport Taiwanese interests domestically rather than abroad.

The representation of the third transportation revolution is not the only way for the THSR to shape the Taiwanese identity. The THSR's content that I characterize as "hybrid engineering" also facilitates a Taiwanese differentiation from others. This project explores the THSR's engineering content. Among other countries that have initiated HSRs,¹⁷ the THSR is unique in that it is the first exported HSR technology of Japan's Shinkansen. However, due to its policy history, the THSR was viewed as a hybrid design of Japanese and European technology because it also adopted some technology from France and Germany. As Christopher Hood points out,

¹⁵ See Japan Airlines, "World Top 11 City-Pairs," *SORA Data File*, 2004.

¹⁶ See MOTC, *Six-Year National Development Plan: MOTC Part 1992-1997* (六年國建計畫: 交通部部分) (Taipei: MOTC, 1992). Also see You-hsin Eugene Chien (簡又新; MOTC minister), "Promoting the Western Taiwan Corridor: HSR's Policy Background," *Central Daily Times*, July 28, 1992.

¹⁷ For example, South Korea and China adopt France's TGV (transposition of the great vessels) and Germany's ICE (inter city express) systems respectively.

“[t]he Japanese are already beginning to emphasize that the THSR is *not* a Shinkansen and are gradually distancing themselves from responsibility for the project.”¹⁸

This project intends to study engineering hybridization in terms of the complicated process of how to reconcile the different HSR subsystems in the THSR. In addition, hybridizing an advanced and complex technology like HSR also requires knowledgeable hybridizers. To practice complicated processes and develop knowledgeable hybridizers requires experienced engineers and some of their special historical backgrounds. Therefore, this project also attempts to investigate the engineering knowledge, practice and cultural background that the Taiwanese engineers shared with each other. Moreover, to explore the engineer community could also reveal what Taiwan’s development trajectories have been. As Gary Lee Downey and Juan C. Lucena have pointed out, “When nations redefine their priorities and re-plot their definitions of travel, engineers get worried about the content of their knowledge.”¹⁹

By investigating Taiwanese engineers, the notion of ‘hybrid engineering’ revealed from this project means an engineering culture that values hybridity. Its specific engineering practice includes designing for inclusion, managing for mediation and learning through collaboration. Besides, the Taiwanese politics and society gradually directed its engineers to pursue engineering optimization and non-dependence rather than seeking simply survival or perfection. This project shows how Taiwanese engineers integrated different technological subsystems from different countries. In addition, it shows their engineering thinking of applying different foreign engineering knowledge to deal with problems and even to create appropriate solutions for the local. This project also attempts to demonstrate that the phenomenon of engineering hybridization was shaped by Taiwan’s international and domestic politics and history. In other words, Taiwan’s engineering culture of hybridity has not only been developed within its engineer

¹⁸ Christopher P. Hood, *Shinkansen: From Bullet Train to Symbol of Modern Japan* (NY: Routledge, 2006), 205.

¹⁹ Gary Lee Downey and Juan C. Lucena, “Knowledge and Professional Identity in Engineering: Code-Switching and the Metric of Progress,” *History and Technology* 20 (2004): 394.

community but also been constructed by its politics and society. The engineering culture of hybridity thus became a culture that the Taiwanese constructed and shared in their society.

Taiwanese engineers have built a unique version of HSR instead of just another Shinkansen or some other foreign HSRs on the island of Taiwan in terms of engineering. The above Japanese response also indicates that the Taiwanese have made them unable to recognize their technology and, more importantly, showed a local ability to build and operate a self-own technology independent from other power outside their island. This project explores how the Taiwanese engineers hybridized and redesigned the HSR technology, investigates what the history of the engineering culture of hybridity is, and discloses how Taiwanese engineers and their sense of identity connect and evolve with each other. As a result, the key difference of the THSR project from other past Taiwanese infrastructure projects shows that some of the people on the island of Taiwan has turned to focus on practicing and applying what engineering expertise they have, reviewing and inspecting who they were/are, and imagining what they want and who they want to be in terms of self-identity.

Chart 1.1 briefly outlines the history of the THSR project, Taiwan's important infrastructure and national projects and its political and societal changes especially during the period from 1973 to the present. I divide the THSR history into four stages. Chapter two focuses on the Taiwan Railways' cannibalization history and HSR experience in stage one before 1973. Chapters three and four discuss the engineering designing and planning politics of the Taiwan HSR project in stages two and three. They reveal an emergent engineering culture of hybridity and Taiwanese identity before the middle of the 1990s. Chapters five and six explore and explain the THSR's hybrid engineering practice and knowledge in detail. Chapter seven argues how the engineering culture of hybridity reflexively strengthened and built the Chinese/Taiwanese identity discourses.

Chart 1. 1 The Important Historical Events of the THSR Project and Its Political Background

(public domain and used under fair use guidelines)

Year	Political Background	Infrastructure/Taiwan Railways/THSR Projects
Stage 1		
1895	Taiwan was ceded to Japan by the Qing China.	
1908		The West Trunk Line completed.
1945	The Republic of China took over Taiwan after the end of World War II.	
1949	The Republic of China (KMT) government fled to Taiwan after its failure against the Chinese Communist regime in Chinese Civil War.	
1951	The specific U.S. aid entered to Taiwan.	
1959		Taiwan Railways proposed the electrification project.
1963	The U.S. stopped its specific aid to Taiwan.	
1973		Taiwan Railways began the Electrification project. It also proposed the Super Rail project. The central government launched the Ten Major Construction.
Stage 2		
1974		The Taiwan Provincial Government approved Taiwan Railways to conduct the Super Rail research.
1978		The Sun Yat-Sen Highway was completed. The central government launched the 12 New Project.
1979	The Republic of China terminated the diplomatic relationship with the U.S. United Nations.	The Ten Major Construction was completed ,including the Electrification project.
1981		Super Rail project was suspended.
1984		The central governmental launched the 14 Major Plans.

Year	Political Background	Infrastructure/Taiwan Railways/THSR Projects
1987		MOTC replaced Taiwan Railways to work on the HSR feasibility project (WT-HSR-FS).
Stage 3		
1988	Republic of China/KMT president Ching-kuo Chiang died. Teng-hui Lee took the president office.	
1990	Lee was elected as the 8 th president of Republic of China by the National Assembly. Hau was appointed by Lee to be the Executive Yuan premier.	The POHSR established. The French SORERAIL was commissioned to do HSR general planning project (WT-HSR-GP). Hau proposed 6-Year National Plan for the Republic of China.
1991	Lee declared the Period of Communist Rebellion to be terminated and gave a new China policy of giving up the objective of reclaiming control over China by military force.	Economic Council fought for HSR project against Ministry of Finance.
1992	The Second Legislative Yuan was elected in Taiwan (the First was in China in 1947).	
1993	Lee proposed his political idea of living community for Taiwan. Hau was replaced by Lien to be the Executive Yuan premier.	Lien revised the 6-Year National Plan to be Stimulus Program and 12 Plans. The Legislative Yuan cut HSR budget and made a resolution to the Executive Yuan that the HSR project shall be built mainly private investment.
1995	Lee gave a talk titled “With People’s Heart Always in My Mind” at Cornell University.	
1996	Lee was elected as the 9 th president of the Republic of China by the Taiwanese population. PRC launched test missiles right before the presidential election. The U.S. sent the 7 th fleet to Taiwan Strait.	The POHSR announced the invitation to tender for the HSR Private Investment (BOT) Project.
Stage 4		
1997		The POHSR transformed to the BOHSR. The THSRC and China Development submitted proposals to respectively

Year	Political Background	Infrastructure/Taiwan Railways/THSR Projects
1998		introduce TGV and Shinkansen systems into Taiwan. The THSRC was chosen to be the best applicant for the HSR BOT project. The THSRC signed the HSR BOT contract with the BOHSR.
1999	Lee proposed his political ideas of “Republic of China on Taiwan,” “special state-to-state relations between Taiwan and China” and “new U.S., Japan and Taiwan relationship.”	Lee proposed to switch the TGV core system to Shinkansen’s for the THSR. The THSRC announced it would negotiate the THSR core system contract with the Japanese Taiwan Shinkansen Corporation prior to Eurotrain.
2000	DPP’s presidential candidate Chen beat KMT’s Lien to rule the government. It was Taiwan’s first democratic transition of power to an opposition party. The THSRC president Ing publicly supported Chen during the presidential election and was appointed as an honorary advisor in the Office of President.	The THSR officially broke ground. The THSRC signed the core system contract with Taiwan Shinkansen in December.
2002		The controversy of the THSR lowering vibration project near the Southern Taiwan Science Park.
2004	DPP’s presidential candidate Chen beat KMT’s Lien again and prolonged the DPP ruling for four more years.	
2005		The THSRC president Ing announced to postpone the THSR’s completion for one more year. The value of the THSRC’s equity was approximately doubled through stock purchases by the Executive Yuan’s fund and some state owned companies and banks.
2006		The THSR building work completed.
2007		The THSR opened to traffic.

Year	Political Background	Infrastructure/Taiwan Railways/THSR Projects
2008	 The KMT's presidential candidate Ma won the office.	
2009		The THSRC president Ing stepped down.
2010		The Control Yuan issued a special report on the THSR project.

1.3 Literature Review

This project is different from other THSR research because it approaches the THSR through the scholarship of science and technology studies (STS). This project also offers a more specific approach to conceptualizing the relationship between technology and identity formation. It focuses on how the indigenous practice of hybrid engineering worked together with their identity formation *in the making*. Rather than nation formation, I use the term identity formation in this project in an attempt to be more precise to respond to the actual identity politics in 1990s Taiwan. This project attempts to reveal what the identity discourses the THSR policy actors were strengthening and building, how these discourses related to the THSR policy, and how the different groups among them were struggling over the issues of identity politics and the THSR policy at the same time.

The idea of identity formation is very close to that of community or nation formation. According to Benedict Anderson's "definition of nation: it is an imagined political community—and imagined as both inherently limited and sovereign."²⁰ A community, however, might or might not develop toward a nation. It might also become different nations under different political construction at different times. This project focuses on the community making process that could create these different possibilities. It intends to explore the deep and horizontal comradeship and fraternity in a nation or community in Benedict Anderson's term. I thus place

²⁰ Benedict Anderson, *Imagined Communities: Reflections on the Origin and Spread of Nationalism* (NY: Verso, 2006), 6.

the notion of identity at the center of this project. As a result, this project is different from some important STS studies that explore the relations between science, technology and nation formation.

Moreover, this project also examines how Taiwanese hybrid technological knowledge has played a resistant role to Japan and the West in the postcolonial context. This project explores how the Taiwanese create their own understanding of transferred technologies, and how this technological hybridization contributes to the formation of an independent Taiwanese culture distinct from the Chinese, Japanese and western cultures.

The literature review is divided into three parts: the literatures of the THSR, HSR, and an investigation of STS approaches to investigating the relationship between technology and identity or community shaping. This review concludes that firstly, no STS research has been done on the THSR, and secondly, current STS approaches have significant conceptual and methodological limitations for this project.

1.3.1 Literature on the THSR

Although the THSR just began its business service in January 2007, it has prompted much study. Bei-Chang Wen (溫蓓章) studies the issues of the THSR's political economy of policy planning and its relationship with state capacity in the 1990s. These two issues actually are closely connected because the configuration of the THSR's planning history represented the evolving transformation of the government and state in Taiwan. The ideology of state development and the active role of the government commonly determine the HSR policy planning. Wen notes that "the study of the THSR's policy planning shows the historical process of democratization and capitalization in Taiwan's state transformation since the 1990s. The transformed bureaucracy worked with the emerging private sector to construct the THSR project.

In the process of state transformation, the HSR policy became a part of the historical plan of maintaining the government's legitimacy and the state's capacity."²¹

In his dissertation "Planning in a Democratized Domain: Democratization and Planning Bureaucracy in Taiwan,"²² Chien-Hung Tung (董建宏) deals with the issues of technology worship and political identity that this project also attempts to discuss. He argues that the history of technology and techno-bureaucracy created the phenomenon that he calls "technology worship" in Taiwan. Tung also argues that the reflection of this worship on the THSR has strengthened the Taiwanese identity especially when the Taiwanese compare the THSR with the Shinkansen and TGV.²³ He claims that, "the Taiwanese society has worshiped modernization, technology and science for a long time. The beginning moment of the THSR's business operation immediately responded to the aspiration of modernization in the Taiwanese society—especially outside the Taipei urban area."²⁴

While Wen and Tung focus on the process of the THSR's policy planning based on political economy and political sociology, this project concerns itself more with THSR's engineering practice and Taiwanese discourse against Chinese discourse. Wen and Tung's institutional approaches mainly concerned how the bureaucracy, congress and the private sector influenced the THSR project in the realm of state capacity and democratization. However, this project investigates (1) how the Taiwanese engineers made the Taiwanese HSR project happen and (2) how the evolving people of Taiwan in terms of identity formation responded to and participated in the THSR planning and construction. Although he addresses the relevant history of technology that contributes to the phenomenon of technology worship and identity formation

²¹ Bei-Chang Wen, "Detouring High Speed Rail in Taiwan: State Transformation and Transportation Planning" (PhD diss., National Taiwan University, 2000), 7-1~2.

²² See Chien-Hung Tung, "Planning in a Democratized Domain: Democratization and Planning Bureaucracy in Taiwan" (PhD diss., Columbia University, 2006).

²³ Chien-Hung Tung, "The THSR Business Operation and the Aspiration of Modernization in the Taiwanese Society," *Contemporary (當代)* 239 (2007): 98-9.

²⁴ *Ibid.*, 86.

in Taiwan, Tung takes technology for granted rather than examining how its technological contents have been embedded within historical dimensions. Tung's research pays more attention to the contemporary political sociology and how technical facilities shape identity, but this project will explore how identity formation has inherently worked together with technology in Taiwan. The ways that Taiwanese do things and identify themselves have been intertwined and shaped by each other.

This project recognizes that evolving engineering practice links Taiwan's histories of identity shaping and technology. This research approach allows us not only to understand the engineering culture of hybridity and localized design in Taiwan, but also entails an exploration of how Taiwan's history of identity shaping shifts with its history of technological development. The developments of technology and engineering practice in Taiwan have been inherently embedded within identity politics. They have facilitated and referred to each other. As a result, Wen and Tung and this project have different target groups and approaches in studying the THSR project. In sum, unlike previous work on the THSR, this project's approach prominently highlights STS scholarship in exploring the connectedness and engineering relationships between technology and identity politics. The existing research that focuses on the THSR's policy history and political sociology pays no attention to its engineering practice and knowledge. Some research has made great contributions in understanding this policy history.²⁵

1.3.2 Literature on HSR

Since HSR was introduced in Japan in the 1960s and in France in the 1980s, many works have examined its relations with the state or society. HSR technology has been studied from the perspectives of professional techniques, transportation policy,²⁶ public decision-making,²⁷ policy

²⁵ See Hood, Tung, Wen, and Shin-Yi Chung (仲心儀), "A Research about Developmental States at Taiwan in the Relationship of State-Business Transformation: The Example of Taiwan High Speed Rail Corporation" (Master thesis, Yuan Ze University, 2004).

²⁶ See Mar Gonzalez-Savignat, "Competition in Air Transport: The Case of the High Speed Train" *Journal of Transport Economics and Policy* 38, 1 (2004): 77~108.

network formulation,²⁸ social impacts,²⁹ cultural symbolization,³⁰ and its interactions with urban development, economic growth,³¹ ecological influence,³² population distribution,³³ and special reconstruction.³⁴

Among these studies on HSR technology, Hood's *Shinkansen: From Bullet Train to Symbol of Modern Japan*, not only investigates the Shinkansen's history and specialties, it also explores its cultural and political impacts, especially the ways it has strengthened Japanese identity. Hood argues that the Shinkansen has become a symbol of modernity, which projects Japan's future and its national superiority in the world. With reference to Shinkansen's literal meaning: new trunk line, it represents a new image for both the Japanese and the world that Japan has been on a superior path of becoming a country that many others could learn from, rather than the exotic and mystical country that it once was.³⁵ In short, the Shinkansen has brought the Japanese a new sense of identity.

However, Hood's study includes no evidence pertaining to engineering practice. In addition, HSR technology has not yet been studied as a transferred technology connecting to its engineering history in the non-western context. Furthermore, while Hood offers insights on how the Shinkansen represents and formats how the Japanese view themselves, this project will

²⁷ See Laurence De Carlo, "The French High-Speed Mediterranean Train Decision Process: A Large-Scale Public Decision Case Study," *Conflict Resolution Quarterly* 24 (2006): 3~30.

²⁸ See James A. Jr. Dunn and Anthony Perl, "Policy Networks and Industrial Revitalization: High Speed Rail Initiatives in France and Germany," *Journal of Public Policy* 14: 3 (1994): 311~43.

²⁹ See Olivier Klien, "Social Perception of Time, Distance and High-Speed Transportation," *Time and Society* 13 (2004): 245~63.

³⁰ See Hood.

³¹ See Pablo Coto-Millan, Vicente Inglada and Belen Rey, "Effects of Network Economies in High-Speed Rail: The Spanish Case" *Annals of Regional Science* 41: 4 (2007): 911~25. Gines de Rus and Gustavo Nombela, "Is Investment in High Speed Rail Socially Profitable?," *Journal of Transport Economics and Policy* 41: 1 (2007): 3~23.

³² See Bert van Wee, Robert van den Brink and Hans Nijland, "Environmental Impacts of High-Speed Rail Links in Cost-Benefit Analyses: A Case Study of the Dutch Zuider Zee Line," *Transportation Research: Part D: Transport and Environment* 8, 4 (2003): 299~314.

³³ See Komei Sasaki, Tadahiro Ohashi and Asao Ando, "High-Speed Rail Transit Impact on Regional Systems: Does the Shinkansen Contribute to Dispersion?," *Transport infrastructure* (2002): 590~611.

³⁴ See Kwang Sik Kim, "High-speed Rail Developments and Spatial Restructuring: a Case Study of the Capital Region in South Korea," *Cities* 17, 4 (2000): 251~62.

³⁵ See Hood, especially chapter 3.

expand this point to explore how Taiwan's identity formation shapes the THSR project as well. The THSR technology would have facilitated Taiwanese identity formation just as in Japan, but what this project attempts to show more clearly is how Taiwan's local and historical identity formation has reframed HSR technology in terms of hybridization.³⁶

Takashi Nishiyama explores how the early Shinkansen's technology was produced. He shows how the wartime aeronautical engineers were forced to leave their military career and later joined the Japanese National Railway (JNR) and its Railway Technical Research Institute (RTRI) between 1945 and 1950. Those military engineers used their aircraft engineering knowledge to solve some crucial problems in high-speed railway engineering. One of the most critical techniques, for example, was to reduce a train's excessive vibration when speeding up. Matsudaira Tsdashi, an aircraft engineer in the navy and later a laboratory leader at the RTRI, applied his experience with designing the Zero fighter aircraft to study the speedy train vibration as an aerodynamic force. He then developed tests and successfully stabilized the high-speed trains.³⁷

In his book *On the Fast Track: French Railway Modernization and the Origins of the TGV, 1944-1983*, Jacob Meunier states that the "TGV was, until the time of its birth, an unwanted child."³⁸ He thoroughly investigates the TGV's history in order to answer questions about what the TGV's social, economic, political and international backgrounds were and how they have shaped what the TGV looks like. Meunier argues that the TGV might have been stillborn like Amtrak's *Acela Express* had it not been for several domestic and international events. The Shinkansen started business service in 1964, which hurt French national pride, even though their Société nationale des chemins de fer français (SNCF, or French National Railways) had

³⁶ See chapters 4 and 7.

³⁷ See Takashi Nishiyama, "Cross-Disciplinary Technology Transfer in Trans-World War II Japan: The Japanese High-Speed Bullet Train as a Case Study," *Contemporary Technology Transfer and Society* 1 (2003): 305-27.

³⁸ Jacob Meunier, *On the Fast Track: French Railway Modernization and the Origins of the TGV, 1944-1983* (Westport, CT: Praeger, 2002), 2.

conducted a test run reaching 331 km/hr in 1955. The competition from road and air service also pushed the privatized SNCF to provide higher speeds and more comfortable service. Another new high-speed transportation technology favored by the French government, Aerotrain,³⁹ also had a significant impact on the birth of SNCF's TGV service. In addition, the energy crisis and public reaction in the 1970s joined to shape what we saw in the TGV's first business run in 1981. In short, as Meunier concludes, "the TGV was not the product of central planning and a deliberate drive toward modernization, but of noisy consensus-building accompanied by several false starts."⁴⁰

Meunier's research shows that the way the TGV has been considered as a sort of French spirit should not be taken for granted. The way the French perceived the TGV before its first run was very different from the way they think what the TGV now. Meunier's historical approach toward studying the TGV offers this research a useful perspective for exploring the THSR. This project adopts Meunier's approach in order to investigate the THSR's social, political and economic histories. However, in addition to like Meunier focuses on how the French background from the 1950s to 1970s shaped the TGV, this project also intends to understand how the THSR's engineers practiced their experience and expertise. In short, an exploration of engineering histories and practices differentiates this project from other high-speed railway studies.

1.3.3 STS Literature on Identity Shaping

The investigation of the interactive relations among science, technology and identity has raised more and more debates. Through close participant observation, Gary Lee Downey discloses a national discourse embedded within those engineering students who were taking an introductory course in CAD/CAM (computer-aided design/computer-aided manufacturing). In

³⁹ See more Vincent Guigueno, "Building a High-Speed Society: France and the Aerotrain, 1962-1974," *Technology and Culture* 49 (2008): 21~40.

⁴⁰ Meunier, 231.

his book *The Machine in Me: An Anthropologist Sits among Computer Engineers*, Downey shows that “merging design and manufacturing through CAD/CAM technology would increase national productivity by enabling companies to respond to changing consumer demands more quickly, effectively and cheaply. CAD/CAM technology would lead America into a future of freedom through competitiveness, saving the nation and guaranteeing social progress by liberating Americans from dependence on foreign industry.”⁴¹ Pursuing productivity was a means instead of an end. CAD/CAM technology was a way to realize the national discourse established upon the doctrine of competitiveness. Those engineering students knew the importance of equipping themselves with CAD/CAM knowledge. They knew every American engineering student knew this. They knew every American engineering student knew every American engineering student knew this. As a result, the acquisition of CAD/CAM technology was not only instrumental in making those students identify themselves as potential engineers but it was also instrumental in making them Americans. Technology was not just to award a professional identity but also to establish a community membership.

Inspired by Downey’s insightful metaphor of “the machine in me,” this project explores the politics and histories in Taiwan’s engineering culture of hybridity that nurtured its local engineers to build the THSR project in a unique way. However, while Downey’s analysis of CAD/CAM technology focuses on how engineers used it to keep themselves tightly linked to the country,⁴² this project extends it by showing that the THSR was judged to be significant across Taiwan as a whole. This project places emphasis on how “Taiwaneseness” has emerged through the facilitation of hybrid engineering culture and practice. In other words, unlike Downey’s account of an “Americanness” able to frame a doctrine of competitiveness, the Taiwanese identity

⁴¹ Gary Lee Downey, *The Machine in Me: An Anthropologist Sits among Computer Engineers* (NY: Routledge, 1998), 15.

⁴² See *Ibid* and Gary Lee Downey, “CAD/CAM Saves the Nation?: Toward an Anthropology of Technology,” *Knowledge and Society* 7 (1992): 143~68.

was still in the making and it has been reflexively shaped by Taiwan's engineering development. This project demonstrates that Taiwan's identity formation and its engineering culture of hybridity have been intertwined and have reinforced each other.

In his book *Science, Culture, and Modern State Formation*, Patrick Carroll "suggests that the co-construction of science and government can be understood as a specific causal mechanism that explains the peculiar form of the modern state compared with other states."⁴³ He uses the Irish case to show how natural philosophy, mathematics and engineering in 17th century Ireland were integrated as a culture. This cultural integration that he terms "engine science" was intertwined in the process of state formation. In other words, Carroll argues that science has been included as a part of culture that facilitated the formation of the state of Ireland. He insightfully adds a perspective from STS scholarship to historical sociology to enhance our way of understanding modern state formation.

This project benefits from Carroll's Irish case study in terms of the conceptualization of the relation between science and state formation. However, while Carroll focuses on state formation showing how governments and science together formulate modern states, this project concerns the phenomenon of identity formation in which some people tend to locally develop their connected culture through, among others, their engineering practices. Although engineering played an inalienable role both in state and identity formation, the different actors acquired and practiced engineering in different ways. In the case of Irish state formation, the English government shaped the state of Ireland with its domination of engineering practices, but this inquiry into Taiwanese identity formation is intended to show how the local develops a shared community culture embedded with their engineering experience. This project has attempted to

⁴³ Patrick Carroll, *Science, Culture, and Modern State Formation* (Berkeley, CA: University of California Press, 2006), 7.

be more bottom-up oriented in its way of addressing how some of the indigenous people regard and practice engineering.

In *The Radiance of France: Nuclear Power and National Identity after World War II*, Gabrielle Hecht studies the relations between French nuclear plants, policy and identity.⁴⁴ She argues that both the physical artifacts and operational systems in the nuclear power plants are like “hybrids of technology and politics”⁴⁵ in France. The construction of nuclear power plants and its policies in France could not be reduced to either technology or politics alone. Hecht refers to the French nuclear power plants as a representation of technopolitics. The French nuclear policy research approach that Hecht conceptualizes offers insights for this project by suggesting ways of exploring how Taiwanese engineers designed and conceptualized their job within their organizations in the THSR project.

However, this project belongs to the recent past in comparison with Hecht’s study. Also, this project is looking at how technology interacts with identity in the making, which differs from Hecht’s work exploring the relationship between technology and identity in the past. Moreover, in addition to adopting Hecht’s approach to exploring agencies’ strategies, engineers’ experience and their interaction, this project also characterizes how the transformative phenomenon of engineering knowledge works with Taiwanese engineers. A later portion of the literature review of postcolonial science studies will discuss this point further.

In *Engineers of Happy Land: Technology and Nationalism in a Colony*, Rudolf Mrázek explores cultural transitions in the Netherlands East India from the mid-nineteenth century to the early twentieth century by investigating how technology contributed to shape nationalism. As

⁴⁴ See Gabrielle Hecht, *The Radiance of France: Nuclear Power and National Identity after World War II* (Cambridge, MA: MIT Press, 1998).

⁴⁵ Gabrielle Hecht, “Technology, Politics, and National Identity in France,” in *Technology of Power: Essays in Honor of Thomas Parke Hughes and Agatha Chipley Hughes*, ed. Michael Thad Allen and Gabrielle Hecht (Cambridge, MA: MIT Press, 2001), 256.

Mrázek describes, “Spiritualism...worked at least as fast as the (radio) wire.”⁴⁶ He offers insights into how technology becomes an agent of colonialism and nationalism. However, this project does not just go from a technology to its political impacts only. It will also examine how the struggles over Taiwanese identity take place in technological form, i.e., in struggles over HSR technology.

Some other studies also examine the issue of the relationship among technology, identity and state.⁴⁷ They offer some approaches to examining how technology and state politics effectively shape each other. However, the relationship between technology and state politics is as complicated as in Hecht’s and Mrázek’s works. This is not only because different contexts produce different relations, but also because different research approaches show how differently these relations might look. This project’s one probing approach focuses on how engineering practice and knowledge connect to politics. This would make it unique in STS scholarship.

In addition, an emerging field of research in postcolonial science studies (PSS) within STS scholarship is highly relevant to this project as well. More and more STS researchers have contributed to understanding “the co-production of identities, technologies and cultural formations characteristic of an emerging global order.”⁴⁸ Warwick Anderson comments that some PSS notions such as “the localness of technoscientific networks, the situated production of ‘globality,’ the transnational processes of displacement and reconfiguration, the fragmentation and hybridity of technoscience are all vividly illustrated in the multi-sited studies of Hecht,⁴⁹

⁴⁶ Rudolf Mrázek, “‘Let Us Become Radio Mechanics’: Technology and National Identity in Late-Colonial Netherlands East Indies,” *Comparative Studies in Society and History* 39 (1997): 4.

⁴⁷ See Mikael Hård, “German Regulation: The Integration of Modern Technology into National Culture,” in *The Intellectual Appropriation of Technology*, ed. Mikael Hård and Andrew Jamison (Cambridge, MA: MIT Press, 1998), 33~68. Jeffery Herf, *Reactionary Modernism: Technology, Culture, and Politics in Weimer and the Third Reich* (NY: Cambridge University Press, 1984).

⁴⁸ Warwick Anderson, “Postcolonial Technoscience,” *Social Studies of Science* 32 (2002): 643.

⁴⁹ See Hecht, “Rupture-Talk in the Nuclear Age: Conjugating Colonial Power in Africa,” *Social Studies of Science* 32 (2002): 691~727.

Redfield⁵⁰ and Adams.^{51,52} These notions are valuable STS and PSS assets for this project. However, while most of these notions highlight the interactions between western science, technology and indigenous knowledge, this project examines one possibility of a kind of emerging localized-techno knowledge in terms of, first, transforming western transferred technologies in a locally hybrid way, and second, using this transformed hybrid technological knowledge to reframe and negotiate to the more advanced technologies from the West and Japan.

For some Taiwanese engineers, for example, one of the reasons that they mix transferred technologies is that they previously experienced how the Japanese hybridized technologies. Then, they created their own engineering practice and knowledge by hybridizing the Japanese, American and European technologies. Thus, this phenomenon of engineering hybridization is a localized-techno product special to Taiwan. It even becomes a means of resistance against Japan and the West.⁵³ This story is not only about an effort to formulate a nationalist engineering project that helped to create a distinct Taiwanese identity, it is to do so in a technopolitical world that challenges the notion of national technology. No PSS research, as Chyuan-yuan Wu (吳泉源) points out, offers conceptual approaches for understanding how western scientific and technological knowledge locally evolves and transforms in those emerging developed countries that previously were colonies, such as Taiwan.⁵⁴ Nor does PSS research focus on the Japanese colonial contexts. This project, therefore, fills a gap in the fields of PSS and postcolonial studies.

1.4 Research Methods

⁵⁰ See Peter Redfield, "The Half-Life of Empire in Outer Space," *Social Studies of Science* 32 (2002): 791~825.

⁵¹ See Vincanne Adams, "Randomized Controlled Crime: Postcolonial Sciences in Alternative Medicine Research," *Social Studies of Science* 32 (2002): 659~90.

⁵² Warwick Anderson, 651~2.

⁵³ See chapter 6.

⁵⁴ See Chyuan-Yuan Wu, "Technology and the Study of Technology in Taiwan," *Contemporary Monthly (當代)* 176 (2002): 64~73. Also see John M. Staudenmaier, "Recent Trends in the History of Technology," *American Historical Review* 95 (1990): 715~25.

Because the THSR has two different technology sources, Japan and Europe, one of the foci of this project is to determine how Taiwanese engineers made hybrid technologies possible, and how they represented and operated them in a localized way. The first key issue in this research is to understand how the Taiwanese engineers were able to mix the transferred HSR technologies from Japan and Europe. By analyzing my interview data and primary source materials, this project examines how THSR hybrid engineering practice was a product of the earlier history of technology and politics in Taiwan. It also investigates features of engineering practice in THSR and demonstrates that they have been constructing a kind of localized techno knowledge.

1.4.1 Primary Source Collecting

I interviewed twenty-two THSR engineers or professionals with THSR engineering expertise and experience in order to explore what skills they needed in order to combine different HSR systems of technologies and what difficulties they faced and the solutions they came up with. I also learned about those engineers' professional careers and their work experience through interviews, by which this project is enabled to collect evidence about the historical and social material they utilized to construct their engineering careers and practices in their daily work. Among those of my interviewees, ten are currently engineers in the THSRC, four are former or current Director Generals of the Bureau of High Speed Rail (BOHSR; 交通部高速鐵路工程局)⁵⁵ affiliated with the MOTC, both the president and vice president of CECI Engineering Ltd. (世曦工程顧問公司), which was the main local engineering consultant for the THSR project,⁵⁶ and a deputy Director General of Taiwan Railways. In addition, my other

⁵⁵ The Preparation Office for BOTHSR, MOTC was officially founded on July 2 1990 to manage all works about planning and executing the High Speed Rail (HSR) construction. . .the Executive Yuan commanded and sanctioned setting up the BOTHSR, MOTC on January 31 1997. See <http://www.hsr.gov.tw>

⁵⁶ CECI was the abbreviation of China Engineering Consultants Incorporated. CECI and China Engineering Consultants Incorporated refer to two different institutes since 2007. "CECI Engineering Consultants, Inc., Taiwan was formed in May 2007 as a new company inheriting the duties, responsibilities and all project experience of China Engineering Consultants, Inc., which was originally established in 1969. CECI refers to the past history of China Engineering Consultants, Inc., as well as the present and future operations of CECI Engineering Consultants, Inc., Taiwan." The China Engineering Consultants Incorporated was established by the MOTC with

interviewees are the senior engineers who participated in the THSR project. See the interview list and interviewees' background provided in Appendix A.

Although most of them are located in maintenance and operation divisions, those ten interviewed THSRC engineers participated in civil, electrical and mechanical engineering works during the THSR planning and construction period. Among others, they revealed stories of the struggles and conflicts that arose in the process of integrating the Japanese and European HSR technologies, of the engineering specialties and experiences that they possessed, of the advantages and disadvantages they acquired and confronted, and of the lessons they learned and so on.

Among the four interviewed BOHSR Director Generals, Ping Tong (董萍) held the first term of the position when it was established in 1990. Before leading the BOHSR, Tong served as Director General of the Taiwan Railways and Railway Reconstruction Bureau (Railway Reconstruction; 交通部鐵路改建工程局). Both are MOTC affiliates that are responsible for the operation, maintenance and reconstruction of Taiwan's conventional railway mainly built in the Japanese colonial period. Tong is also a Chinese mainlander and a military engineer who moved to Taiwan with the KMT regime after its defeat by the Chinese communist regime in 1949. Both his conventional railway and Chinese engineering experiences characterized his HSR leadership in the early 1990s. Some of his policies remained to produce significant impacts on the THSR project even after he left BOHSR. Ching-Lung Liao (廖慶隆) is the BOHSR Director General who occupied the position for the longest time in comparison with other Director Generals until the present. The BOT (Build-Operate-Transfer) HSR policy that shifted the THSR's construction work and future operation from the government to the private sector was under Liao's lead. In addition, Liao also witnessed the THSRC earn the HSR project contract in 1998

the help of U.S. aid. Due to reinforcement by the change of the relevant law, it invested to establish CECI. In Chinese, the name of CECI indicates no relation to the term of China but adds Taiwan in front of the title. See <http://www.ceci.org.tw/english/index.htm>

and began its construction work in 2000. Later, Liao transferred to CECI and became its president.

Another Director General I interviewed is Fu-Hsiang Wu (吳福祥) who served in the BOHSR during the period when the THSR approached completion from 2005 to 2007. Among others, Wu shared his policy and experience regarding the verification and validation of the THSR system. I also interviewed the current BOHSR Director General Daniel H. Ju (朱旭). He mainly developed his engineering career in the Department of Rapid Transit System at Taipei City Government.⁵⁷ Ju's appointment to Director General marked the transition of the BOHSR's business focus from the THSR project to the Taoyuan International Airport Access Metro Rapid Transit System project. Moreover, his appointment also reflected the fact that the THSR project had entered into another stage of system operation, management and maintenance where Ju could bring his previous experience of track engineering to the BOHSR. In addition to the above four BOHSR Director Generals, I also interviewed two senior engineering managers with BOHSR experience. One of them is in charge of the section of the THSR rolling stock in the BOHSR. The other currently directs one of the THSRC depots, after he left the BOHSR. Both have worked for the THSR project for years and accumulated a certain amount of practical experience.

The CECI vice president Bol-Yi Tsuei (崔伯義) was also on my interview list. He was the Principal Engineering Investigator of the THSR project for the BOHSR for years.⁵⁸ Tsuei earned his first engineering degree at National Cheng Kung University in Taiwan and received his Masters degree in mechanical engineering in the U.S. He was one of the few Taiwanese graduates from abroad who came back to serve during this early period of the 1970s. I also

⁵⁷ See BOHSR, "From the Director-general of BOHSR", <http://www.hsr.gov.tw/homepage.nsf/beff9cd4905e8649482569210010e4a3/cedfba1a2e45bb2c482570a100135aaa!OpenDocument>

⁵⁸ See Bol-Yi Tsuei, "Review and Prospectus After THSR Open to Traffic," *Engineering (工程)* 81 (2008): 31-46.

included two interviewees with conventional railway engineering experience. One of them is Deputy Director General of Taiwan Railways, Ming-Ren Huang (黃民仁). The other served as a senior engineering manager in the THSRC Kaohsiung depot after he retired from Taiwan Railways. Both provided important information regarding what HSR engineering practice and planning might draw from the hybrid engineering experience of conventional railways.

In addition to the interview material with the engineering professionals of the THSR project, this project also significantly benefits from the voluminous primary reports and documents produced by the BOHSR, MOTC and Taiwan Railways etc. The BOHSR published a series of twenty-eight books on the THSR project since 2004. Other than the project's financial and operation management, most of them focus on its engineering and construction.⁵⁹ The BOHSR and Taiwan Railways have also issued their official periodical publication for years in which some critical policy and engineering discussion could be found.⁶⁰

Moreover, the BOHSR has commissioned dozens of HSR research projects from engineering consulting companies, universities and other professional institutes since its establishment in 1990. It listed thirty-seven research reports since 2001 on its website,⁶¹ but the BOHSR accumulated many more reports than the number open to the public in its library. Those reports and plans' abstracts from 1990 until the present could be retrieved through the *Government Research Bulletin* (GRB) database.⁶² More than one hundred abstracts would be searched with such keywords as Taiwan HSR or HSR engineering. Moreover, the BOHSR has also kept sending its engineers and managers abroad to study other HSR systems in the world. Their reports are also collected in the BOHSR's library. According to the BOHSR website,

⁵⁹ See BOHSR, "BOHSR Publications," <http://www.hsr.gov.tw/homepage.nsf/publication?OpenFrameset>

⁶⁰ They are the *High Speed Rail/HSR Newsletter* (高鐵簡訊) and *Taiwan Railways Journal* (台鐵資料).

⁶¹ See BOHSR, "The List of the Commissioned Research Reports,"

<http://www.hsr.gov.tw/homepage.nsf/5570525aaf0566824825739d000a2023/9eb95e36b8e470f34825739d000c0560!OpenDocument>

⁶² See <http://grbsearch.stpi.org.tw/GRB/quickSearch.jsp>

fifty-nine visiting reports from abroad have been submitted since 2001, but not all of them focus on HSR.⁶³ Most of the visiting reports from abroad regarding HSR after 1989 could be found and accessed through the online database of the *Official Publication Echo Network* (OPEN).⁶⁴ This online database indicated fifty-eight reports directly related to the THSR project with a keyword “HSR” search. They were produced not only by the BOHSR but also by the Taiwan Railways, Railway Reconstruction and MOTC etc.

Given the capacity limitation by the GRB and OPEN systems, I searched those primary governmental HSR archives produced before 1990 through another database called *Navigating Electronic Agencies' Records* (NEAR).⁶⁵ With its help, I requested some original archives and documents from different governmental agencies, such as those Taiwan Railways research reports on HSR produced in the 1970s and 1980s. All of the GRB, OPEN and NEAR databases were built by the Executive Yuan (行政院) of the Taiwan government.⁶⁶ Finally, this project also acquired some primary materials from the Executive Yuan, Legislative Yuan (立法院) and Control Yuan's (監察院) gazette databases.⁶⁷ They offer not only historical HSR policy contents and debates, but also its struggles, conflicts and policy evaluation etc. covering the period since the 1970s.

1.4.2 Field Research Strategies

One of my interviewees is a close relative of mine. After he earned his Masters degree in electrical engineering at National Taiwan University of Science and Technology, he joined the local major engineering consultant company, CECI, and participated in the THSR project from the very beginning of its construction to its completion. He was in charge of reviewing and

⁶³ See BOHSR, “BOHSR Publications.”

⁶⁴ See http://open.nat.gov.tw/OpenFront/report/report_main.jsp

⁶⁵ See https://near.archives.gov.tw/cgi-bin/near2/nph-redirect?rname=simp_search&

⁶⁶ OPEN is the database built by the Research, Development and Evaluation Committee, NEAR by National Archives Administration and GRB by National Applied Research Laboratories. All of these institutes are the Executive Yuan's affiliates.

⁶⁷ See National Central Library Gazette Online, <http://gaz.ncl.edu.tw/>

assisting the planning and installation of the power supply system of the THSR. The system mainly dealt with the electricity power supply that the HSR rolling stock needed, but some other electrical and mechanical systems, such as signaling and communication systems, also depended on the system to supply their needed electricity. Among others, he mainly played a role of gatekeeper in ways of assuring if the THSRC followed CECI's design to build its power supply system. As a result, his frequent communication and collaboration with the THSRC engineers made him able to access to the project's electrical and mechanical planning and practice. He informed me about his HSR engineering knowledge and experience. In addition, he also introduced me to other engineers in the THSRC.

I obtained significant assistance from my relative in screening those numerous HSR research reports, reports from visitors abroad and other primary technical materials. I then approached some THSRC engineers and conducted anonymous interviews with them. Although my relative arranged my introductions to them, most of the THSRC engineers were very suspicious about my interview invitation since the THSR project has been one of the most controversial and politically sensitive issues since the 1990s and remains so today. They worried that I would disclose their identities and release unexpected opinions against their employer, the THSRC, to the media. However, after repeatedly expressing my research intention and explaining the interview process, a senior THSRC engineer in terms of experience and age agreed to meet me. We met in his THSRC office and conducted the interview in a coffee shop on a different floor in the same building. He insisted that he would not sign any document including the informed consent form. Nor did he allow me to tape our conversation. But he was fine with my note-taking during the interview. Later, he helped me convince some other THSRC engineers whom I planned to conduct interviews with, but he also communicated this interview scheme to his colleagues regarding the use of no tape recordings or signatures. I met these

THSRC interviewees in their offices as well, but we did interviews at corners or meeting rooms in the THSRC headquarters. They were not senior enough, unlike my first THSRC interviewee, to leave their offices without permission, so we found relatively quiet and invisible spots at the THSRC.

In addition to the above THSRC interviewees, I also obtained some other THSRC engineers' agreements from the Hsinchu, Taichung and Kaohsiung maintenance depots. The intention of some, especially those high-ranking engineering managers, was obviously that they wanted to share their career stories in these interviews. Some in turn were interested to understand why I framed the Taiwanese engineers as the target group rather than politicians in my research. Their curiosity brought them to accept my invitation. Among others, my educational background as an American doctoral student raised their interests about knowing what western engineers have been studied. They wanted to learn if they are different in any ways from other engineers, especially from advanced countries. Except for one whom I interviewed in a coffee shop on the weekend, I met the others in their offices and interviewed them at corners or meeting rooms somewhere in the depots. In the end, all of the THSRC interviewees declined to sign the informed consent form even though I explained to them it was supposed to protect their identities. They all declined my request to tape our conversation as well. Even regarding our communication on issues such as meeting times and places, most of my THSRC interviewees indicated or implied that they preferred to discuss this subject by cell phone rather than land phone or email in case it left any records.

I interviewed THSRC engineers possessing several different kinds of specialties, such as with electrical and mechanical systems, power supply systems, signaling systems, rolling stock systems and civil construction etc. This project begins to build knowledge through a reinforced process in between interviews with the THSRC and CECI engineers and reviewing those

primary technical sources. Basically, by both investigating the primary technical literature and acquiring those THSR engineers' experience enabled this project to understand the HSR techniques and what techniques the Taiwanese engineers intended to hybridize in the THSR. While they helped discover and understand critical technical knowledge in those primary documents, this project extracted more and more of those engineers' experiences and practices through the further digestion of more and more engineering texts.

This reinforced process later equipped me to conduct further interviews with higher level engineering managers and planners such as those BOHSR Director Generals and CECI presidents. As with the THSRC engineers, the BOHSR and CECI directors were suspicious about signing any documents as well as leaving any written records. Fortunately, most of them allowed me to tape the interview conversation. Generally, these senior engineering planners revealed what kind of engineers they played, what their engineering knowledge was, and what historical engineering considerations contributed to present THSR design and practice. They also further featured what social, political and national backgrounds shaped their identities, their knowledge and those historical HSR engineering factors. As Downey and Lucena insightfully indicate, "the cultural and historical specificity of [engineers'] responses illustrates the extent to which the questions of what counts as engineering knowledge and what counts as an engineer are linked tightly together, and also suggests that both may be tied to local images of the nation."⁶⁸

⁶⁸ Downey and Lucena, 393.

CHAPTER 2

TAIWAN RAILWAYS, INTERNATIONAL POLITICS AND ENGINEERING LABOR UNTIL 1973

Instead of a pure rational product, this project intends to understand the Taiwan HSR as embedded within Taiwanese history. The history of Taiwan Railways is the most direct and critical background that helps this project understand what the Taiwan HSR is, where it came from, and how it was planned and constructed. This chapter focuses on the 1950s, 1960s and early 1970s, which I consider to be the first stage in the story of the Taiwan HSR project. Based on this chapter, the next chapter explores what engineering experience was transferred to the Taiwan HSR project and how the early experience was adjusted and evolved in the project.

2.1 Historical Background of Taiwan Railways Engineering: Engineering Practice with Little Local Participation

Although it was the first Chinese province that successfully built an official railway that was allowed by the Qing court,¹ Taiwan had few chances to significantly improve its railway industry and technologies in terms of engineering research and advancement. Taiwan Railways and its previous institutes during the Qing China and Japanese colonial periods mainly dedicated its efforts to operate and maintain their railroads. This ongoing engineering optimization of the existing system has characterized Taiwan Railway's technological developments. Moreover, it has also generated a phenomenon of engineering hybridization in Taiwan Railways. These phenomena and outcomes are the main themes in this and the following chapters. In addition, these phenomena and practices of engineering optimization and hybridization might not be exceptional to Taiwan's other technological industries.

¹ See Ming-Ren Huang (黃民仁) ed., *History of Transport Engineering, Volume II: Railway Engineering* (Taipei: Chinese Institute of Civil and Hydraulic Engineering, 2008), chapter 2 and 3.

In 1887, Qing China's governor of Taiwan, Ming-Chung Liu (劉銘傳), invited German and English engineers to Taiwan to construct the first official railway in China.² Although he established an official factory in order to maintain, repair and produce relevant railway machines and equipment, Liu did not receive further financial support from the Qing China government to operate his railway.³ Liu's railway was handed over to the Japanese in 1895. At the end of the period of Qing China's governance, the Qing Taiwan government completed the 106.7 km railroad from Keelung (基隆) to Hsinchu (新竹) in the northern Taiwan in 1894.⁴ One year later in 1895, Taiwan was ceded to Japan by Qing China after the Sino-Japanese War. The Japanese then reconstructed the railway and extended it 297.3 more kilometers from Hsinchu to the city of Kaohsiung (高雄) in southern Taiwan. In 1908, for the first time in Taiwan's history the island was connected from north to south along its west corridor by a 404 km railroad. With some additional important construction and improvements over time, this railroad has come to be called the Trunk Line or West Trunk Line (West Trunk; 縱貫線/西部幹線),⁵ which means that it had been the main land transport carrying most of the north-south traffic on the island of Taiwan. The Japanese continued to expand Taiwan's railway network after 1908. Among other things they completed the Coast Line (海線) from Hsinchu to Changhwa (彰化) in 1922, the Chao-Cho Line from Kaohsiung to Chao-Cho (潮州) in 1923, the I-Lan (宜蘭) Line from Badu (八堵) to Suao (蘇澳) in 1924, and the Taitung Line from Hualien (花蓮) to Taitung (台東) in 1926. The Japanese were intended to make a circle network around the island. They even planned to build railroads across the island in the middle.⁶ However, the onset of the second Sino-Japanese War,

² Te-Nian Chen (陳德年), "Railway Electrification," *Engineering (工程)* (1975): 834-35.

³ See Ming-Ren Huang ed., chapter 2. Also see Shan-Shan Wang, (王珊珊) *Modern Taiwan Conventional Rail and Cargo Transportation, 1887-1935* (Hsinchu, Taiwan: Bureau of Cultural Affairs, Hsinchu County Government, 2004).

⁴ *Ibid.*

⁵ *Ibid.*

⁶ See Shan-Shan Wang and Long-Bao Tsai (蔡龍保), *Taiwan's National Railroad in Mid-Japanese Colonial Period, 1910-1936* (Taipei: Taiwan Bookstore Publications, 2007).

which began in 1937, and the Pacific War that followed soon thereafter caused the Japanese to halt their railway plans. Figure 2.1 shows Taiwan's railway network in 1930, but it remained largely unchanged until the end of World War II.

Figure 2. 1 Taiwan Railways in 1930 (West Trunk Line: Keelung—Kaohsiung)
(used under fair use guidelines)



Source: Yuzin Chiautong Ng (黃昭堂), *Japanese Governor-General of Taiwan*, translated by Yin-Je Huang (黃英哲) (Taipei: Liberal Times Publications, 1983).

The Japanese dominated railway engineering and industry in colonial Taiwan from 1895 to 1945. They designed and constructed the routes, railroads and stations; they imported locomotives and trains from Japan; their manpower operated and maintained the railways etc.⁷ The Taiwanese had few chances to acquire railway education and professional experience. Although some of the Taiwanese were able to study rail technologies in Japan and took some management positions in the Japanese version of Taiwan Railways, most of them were hired as a low-rank labor force or technicians.⁸ After the Japanese left in 1945, Chinese railway engineers and managers filled their engineering and management positions. Most of the Taiwanese employees still remained where they were.⁹ However, instead of the government of the Republic of China, Taiwan Railways' technological reliance shifted from Japan to the government's strongest supporter, the U.S., even though Chinese railway engineers replaced the Japanese.

2.2 Emerging Local Engineering Involvement Surrounded by Foreign Power

Following some suggestions from the Taiwanese Provincial Assembly (台灣省議會) and some official transport departments,¹⁰ Taiwan Railways submitted a research proposal to the Provincial Government in 1973 for building a high speed rail along the west Taiwan corridor. This research proposal was called the "Research Project on the Development of Constructing Super Railway" (Super Railway Research; 發展建設超級鐵路研究計畫) after it was approved by the Provincial Government in 1974.¹¹ Taiwan Railways soon established the Super Railway

⁷ *Ibid.*

⁸ See Jun-Ming Huang (黃俊銘), *A Journey of History of Taiwan Railways: Guides to Taiwan Railways Archives in Japanese Colonial Period and after the Second World War* (Taipei: National Archives Administration, 2009), chapter 11. Chien-Hwa Liu (劉建華), "The Review and Expectation on Taiwan Railways' Workforce Development," in *Century Memorial Collection on Taiwan Railways Administration*, ed. Jun-Ren So (壽俊仁) (Taipei: Taiwan Railways Administration, 1987), 410~3. Also see Long-Bao Tsai, chapter 3.

⁹ *Ibid.*

¹⁰ Taiwan Railways Administration, *The Year-1975 Work Report of the Research Project on the Development of Constructing Super Railway, Volume I* (Taipei: Taiwan Railways Administration, 1975), 1. This report does not clearly indicate what the official transportation departments were, but, according to Taiwan's government framework, they should be referred to MOTC and its affiliates.

¹¹ Taiwan Railways Administration, *The Year-1975 Work Report of the Research Project on the Development of Constructing Super Railway, Volume I*, 5~6.

Research team,¹² which then spent eight years conducting relevant research and it submitted a total of thirteen reports¹³ to the Provincial Government and the MOTC of the central government. Most of the team members were experienced engineers who migrated from China after 1945, according to an interview with Taiwan Railways' current Deputy Director General Ming-Ren Huang.¹⁴

While Taiwan Railways was conducting HSR research in the 1970s, it was dedicating its major efforts to the electrification project for the West Trunk and the construction project of the North Link Line (North Link; 北迴鐵路).¹⁵ Both the West Trunk and North Link projects were later listed in the Ten Major Construction Project (Ten Major Construction; 十大建設)¹⁶ in the 1970s. The West Trunk was the most important transport infrastructure on the west Taiwan corridor, where more than ninety percent of the Taiwanese population resided, from the early colonial period until the early 1980s. Taiwan Railways proposed the super railway as another effective means of transportation fifteen years after the electrified West Trunk traffic might become saturated.

2.2.1 Early Cannibalization as a Way of Surviving under a Difficult Economy and Distorted International Politics

¹² The team consisted of seven sections: environmental analysis, traffic forecast, operation research, rolling stock engineering, mechanical engineering, electric power supply and financial planning.

¹³ The Super Railway Research team submitted a report every half year from 1975 to 1980. Their last report was completed in 1981. See Ling Hsu (徐琳), "Review on the Taiwan HSR Construction Specifications," *Taiwan Railways Journal* 179 (1978): 1~9. Chung-Ho Sun (孫中和), "Taiwan Railways' Step into Modernization," in *Century Memorial Collection on Taiwan Railways Administration*, ed. Jun-Ren So, 315.

¹⁴ An interview with Ming-Ren Huang, 2009.

¹⁵ The total length of the North Link Line was 86.6 km from Suao (蘇澳) to Hualien (花蓮) in the north-east of the island of Taiwan. It was completed in 1979 and opened to traffic in 1980. See <http://www.railway.gov.tw/en/yearbook/yearbook-4.aspx> accessed on Oct. 20, 2009. Also see Fu-Hen Chyu (瞿福亭), "North Link Line Railway," *Engineering (工程)* (1975): 851~58.

¹⁶ The Ten Major Construction Projects (十大建設) was a national development program that included infrastructure projects during the 1970s in Taiwan. They include the National Highway, electrification of the Western Line railway, the North-Link Line railway, the Taiwan Taoyuan International Airport, Taichung Port, Suao Port, the China Shipbuilding Corporation (CSBC) Shipyard, China Steel Factory, an oil refinery and industrial park and nuclear power plant.

Since some mountainous and fossil-fuel-lacking countries had chosen electric-powered railway service, the Council for United States Aid¹⁷ in the government of the Republic of China suggested its MOTC, Provincial Government, Taiwan Railways and Taiwan Power Company (Taiwan Power; 台灣電力公司) to jointly conduct research on the West Trunk's electrification project in 1958. The Council of U.S. Aid required Taiwan Railways to do some research preparation in advance and expected this project would get the U.S. International Cooperation Administration, Mutual Security Mission to China's (Mutual Security) financial aid in an expected future.¹⁸ Taiwan Railways first proposed the electrification project for the West Trunk in 1959, as it claimed, after it had struggled to confront the rapidly increasing traffic after World War II and an anticipated greater commuter need in the near future.¹⁹ Among some other proposals, including adding one more track to the West Trunk or straitening some parts of its original route, upgrading the locomotives was a feasible approach to alleviate the growing traffic demand for Taiwan Railways because of its relative low cost compared to other proposals.

Taiwan Railways thus planned to import more locomotives powered by either diesel or electricity in order to alleviate the increasing traffic. However, importing diesel locomotives was a more practical option for Taiwan Railways. More specifically, the engine on the locomotive was powered by diesel, but it transformed mechanical power to electricity that then drove the electric generator to pull train cars. This design looked complicated but brought some advantages in terms of operation and maintenance.²⁰ At the time, the U.S. government had

¹⁷ The Council of U.S. Aid was established by the Republic of China and the U.S. government in Nanjing in 1948. After its reorganizations over time, the Council has become the Council for Economic Planning and Development under the Executive Yuan. It has been the most important agency of economic consulting in Taiwan. See Council for Economic Planning and Development, "History and Mission,"

<http://www.cepd.gov.tw/encontent/m1.aspx?sNo=0001432&key=&ex=%20&ic=&cd=>

¹⁸ See Taiwan Railways Administration, *Introduction to Taiwan Railways Administration* (Taipei: Taiwan Railways Administration, 1977). Also see Jun Hsu (許俊), "Archives of the Taiwan Railways Administration's Electrification Project, Part One" *Taiwan Railways Journal* 194 (1979): 78~88.

¹⁹ See Taiwan Railways Administration, *General Report of the Electrification for the West Trunk Line* (Taipei: Taiwan Railways Administration, 1979).

²⁰ Taiwan Railways Administration, *Centennial History of Chinese Railway Construction* (Taipei: Taiwan Railways Administration, 1981), 142~3.

decisive power over the government of the Republic of China on Taiwan since its financial assistance, among others, covered almost one-third of Taiwan's annual capital expense.²¹ The U.S. Mutual Security disagreed with Taiwan Railways' electrification project because it viewed this project as similar to projects in the U.S. in the late 1920s. Some U.S. railways began to accrue significant deficits after their electrification projects in 1927. Besides, the U.S. aid agencies also argued that Taiwan was unable to produce sufficient electricity for Taiwan Railways to run electric-powered trains. Therefore, by 1982 Taiwan Railways had imported a total of 149 diesel-electric locomotives of six different types from the U.S. and twelve from Japan.²² Even though French and Japanese engineers came to visit Taiwan Railways in the 1950s and 1960s and suggested it to do a electrification project, Taiwan Railways had neither financial nor policy support from the government of the Republic of China or, to be more specific, from U.S. Mutual Security, to carry out the project at the time.²³

Before the West Trunk became electrified in the 1970s, Taiwan Railways' main efforts were to repair and maintain its railroads, bridges, stations, locomotives and other rolling stock equipment.²⁴ In addition, Taiwan Railways engineers began to design and even make some relevant components.²⁵ Among others, its diesel-electric locomotives brought Taiwan Railways

²¹ See Neil Jacoby, *U.S. Aid to Taiwan: a Study of Foreign Aid, Self-help, and Development* (NY: Praeger, 1966).

²² Taiwan Railways received 246 steam locomotives after the Japanese left in 1945, but 54 were damaged during the war. In addition, more than half of the steam locomotives were more than thirty years old. Although Taiwan Railways introduced few steam locomotives from Japan since then, it, under the U.S. aid's suggestion, turned to import diesel-electric locomotives from the U.S. and Japan after 1950. See Ming-Ren Huang ed. Jun-Ren So ed., *Century Memorial Collection on Taiwan Railways Administration*. Taiwan Railways Administration, *Centurial History of Chinese Railway Construction*. Kuomintang Central Committee of Design and Evaluation, *Introduction to the Taiwan Railways Administration Business, 1950-1955* (Taipei: Committee of the Kuomintang Railway Department, 1955).

²³ Te-Nian Chen, 836. Taiwan Railways Administration, *Centurial History of Chinese Railway Construction*, 49~50.

²⁴ See Kuomintang Central Committee of Design and Evaluation; Su Huang (黃恕) *et al*, "Strategies of Preventing Malfunction to Gas-locomotives," *Taiwan Railways Journal* 24/25 (1965): 1~18/1~16. De-Jen Tien (田德儉), "Engine Functional Trials on Hitachi R0 and R1 Gas-Locomotives," *Taiwan Railways Journal* 31 (1966): 42~50. Chen-Hsin Bien (卞政新), "Aerial Cranes Self-making for Gas-locomotives Factories," *Taiwan Railways Journal* 34 (1966): 1~20. Bei-Tsun Lee (李柏村), "Improvement Study on Track Electrical Communications I/II/III/VI," *Taiwan Railways Journal* 50/51/52/53 (1967): 1~13/1~16/1~13/1~7.

²⁵ See Shi-I Wang (王世一), "Accessories Self-making for Gas-locomotives," *Taiwan Railways Journal* 60 (1968): 1~20. Chun-Chia Huang (黃傳甲), "Study on Self-making Gas-locomotives," *Taiwan Railways Journal* 95 (1971):

the most significant “engineering business” because they often broke down, mainly because of their heavy work load. Practically, Taiwan Railways was not allowed to leave those out-of-order locomotives aside and wait for the Japanese and American engineers to come and fix them. Its West Trunk played an irreplaceable transport role in Taiwan before the Sun Yat-sen National Highway opened to traffic in 1978.

Taiwan Railways gradually developed its own way to fix and maintain those Japanese and American locomotives. Among the 161 diesel-electric locomotives imported in the 1960s and 1970s, 130 of them are still in service. Most of them are even running on Taiwan Railways’ West Trunk and other main routes. These locomotives have been used for thirty years at least. Some of their longevity even remarkably reached fifty years.²⁶ All of their original makers had stopped producing their types and ceased making relevant parts a long time ago. Taiwan Railways has been independently keeping these diesel-electric locomotives running for decades. In addition, there were four other locomotives produced by GM (General Motors) in the 1960s that were a part of gifts delivered to the Republic of Malawi for its 40th National Day in 2006. Taiwan’s Ministry of Foreign Affairs, nevertheless, failed to coordinate Taiwan Railways with sending its engineers and technicians to help Malawi.²⁷ Even though the Ministry of Foreign Affairs paid GM for maintaining those four locomotives, one of them was out of order within a year. Taiwan Railways’ Deputy Director General Ming-Ren Huang told me that they felt bad about this but proud of their engineering experience and knowledge.²⁸

1~17. Taiwan Railways Research Team, “Research Report on Self-making Electric-locomotive Accessories, I/II,” *Taiwan Railways Journal* 230/231 (1983): 1~7/1~11. Tien-Chen Tang (湯天成) *et al*, “Improvement Study on GEC 100 MUT Motors,” *Taiwan Railways Journal* 275 (1983): 65~75. See more in *Taiwan Railways Journal* from 1950s to 1980s.

²⁶ See Taiwan Railways Online Museum, “Diesel Electricity Locomotives,” <http://www.railway.gov.tw/museum/train/train02.htm>

²⁷ See *United Daily*, “President Chen to Visit African Friends in Sep.,” July 4, 2006. Also see Taiwan Railways Administration, “Important Events in 2006,” <http://www.railway.gov.tw/intro/introduction-3-3.aspx>

²⁸ An interview with Ming-Ren Huang.

Among their other special engineering practices, Taiwan Railways engineers not only compared Hitachi and GM locomotives' engineering designs, but also mixed them in a manner that, for example, allowed them to successfully put GM engines into the Hitachi locomotives in 1972. According to its special research report, Taiwan Railways imported twelve diesel-electric locomotives from Japan in 1960. However, more than half of them were soon often out of service because of malfunctioning engines. These engines were jointly developed by the Germans and Japanese. Taiwan Railways indicated that the German-Japanese engines installed on the Hitachi locomotives were not well designed. Besides, they were manufactured with low quality materials. Their original design made them hard to maintain and fix by Taiwan Railways engineers because they were much more complex than other engines such as those manufactured by GM. Moreover, it normally took from nine months to one year to produce and ship those repair parts from Japan. Finally, this unpleasant situation brought Taiwan Railways extra expenditures, more than was its expectation at the time. Therefore Taiwan Railways started thinking of replacing the German-Japanese engines with GM's engines on seven of those twelve Hitachi locomotives in 1969.²⁹

Taiwan Railways thought of requesting GM's help but this was still considered too expensive. It then decided to do this hybrid project by itself. One of the major difficulties was the difference in size between the two engines, which made the GM 645E engine hard to fit into the Hitachi locomotive body. In addition, figuring out how to connect the GM engine to the Hitachi electrical generator and other equipment also brought the Taiwan Railways engineers several critical challenges. Moreover, they wanted to accomplish this hybrid project with minimum expenditure. As a result, the Taiwan Railways engineers revealed that they conducted the hybrid project by mixing design and practice together. They often adjusted their design after

²⁹ See Ming-Ray Tung (董民瑞), "Special Report One: Engineering Redesign and Practice on Hitachi Diesel-Electric Locomotives, I," *Taiwan Railways Journal* 106 (1972): 1~29. Also see Taiwan Railways Administration, *Centennial History of Chinese Railway Construction*.

they practiced and *vice versa*. In other words, they equipped no specific plan, original design skill and manufacturing experience to lead their project. Finally, Taiwan Railways alternated seven of the twelve original Hitachi locomotives by replacing the German-Japanese MAN V6V engines with GM's 645E from 1972 to 1976. They were dubbed "the humped" because the Taiwan Railways engineers adjusted the Hitachi body by heightening the rear of those locomotives several inches. Figure 2.2 shows the humped Hitachi locomotive "R6" altered by Taiwan Railways in comparison with the original one in figure 2.3. These hybrid locomotives turned out to be successful. They were arranged to serve on the West Trunk in a short time. Four of them are still working. The other five original Hitachi locomotives were removed from service by the 1980s.³⁰

Figure 2. 2 Alternated Hitachi Diesel-Electric Locomotive (public domain)



Figure 2. 3 Original Hitachi Diesel-Electric Locomotive (public domain)



Source: Taiwan Railways Museum <http://www.railway.gov.tw/museum/index.htm>

After the U.S. terminated its aid to the government of the Republic of China on Taiwan in 1964, Taiwan Railways hired the Kennedy & Dunkin Consultant firm from the United Kingdom

³⁰ See *Ibid*. Also see Ming-Ray Tung, "Special Report Two: Engineering Redesign and Practice on Hitachi Diesel-Electric Locomotives, II," *Taiwan Railways Journal* 107 (1972): 1~19. Ming-Ray Tung, "Supplement Report One on Alternating 'R1' Power Equipments," *Taiwan Railways Journal* 114 (1973): 84~91. Ming-Ray Tung, "Supplement Report Two on Alternating 'R1' Power Equipments," *Taiwan Railways Journal* 115 (1973): 98~108. So ed., 70. Taiwan Railways Museum Website <http://www.railway.gov.tw/museum/index.htm>

(U.K.) to evaluate the electrification project in 1970.³¹ Soon thereafter Taiwan Railways gained the World Bank's support to conduct some relevant planning in 1970.³² Although the government approved the electrification project one year later, it asked Taiwan Railways to finance this project by itself.³³ This was the only electrification project that received no government subsidy since the Milwaukee railway case in the U.S. that occurred forty years earlier.³⁴ Taiwan Railways' electrification project was an upgrade program in terms of capacity and speed. It was planned and implemented by an international engineering collaboration. Taiwan Railways invited a German railway engineering consultant company, DEC, to design this project's technical specifications. In addition, a U.K. company, GEC, mainly provided the electrification equipment, its construction techniques, twenty electric locomotives and all sixty-five EMU (electrical multiple unit) trains; the U.S.'s General Motors offered Taiwan Railways seventy-four electric locomotives and most of the rail track equipment; while Sweden's L. M. Ericson was responsible for the electrical signaling system. Basically, the U.K. company GEC was primarily in charge of the project. The project's framework was that Taiwan Railways learned technical designs from DEC's (German) suggestions, and then followed GEC's (U.K.) technical requirements to coordinate them with General Motors (U.S.) and Ericsson's (Sweden) subsystems.³⁵

Taiwan Railways contracted the so-called package deals with the above foreign partners, in which they agreed to supply relevant equipment, construction and maintenance techniques while offering financial loans all together. After those package deals were signed in June 1974,

³¹ So ed., 53. Taiwan Railways Administration, *Centurial History of Chinese Railway Construction*, 49~50.

³² See Taiwan Railways Administration, *The Year-1975 Work Report of the Research Project on the Development of Constructing Super Railway, Volume II*, 2-3.

³³ See Te-Nian Chen, 831~50.

³⁴ *Ibid*, 840.

³⁵ See Taiwan Railways Administration, "Outline of the Progress of the Railway Electrification Engineering," *Engineering* (1975): 564~5. Taiwan Railways Administration, *Centurial History of Chinese Railway Construction*, 49~50.

Taiwan Railways established an Electrification Unit³⁶ and sent its engineers abroad to study those techniques. According to Taiwan Railways' reports, the electrification project for the West Trunk grouped together railway engineers from the U.K., Germany, the U.S., Sweden, Japan, Australia, India and Pakistan. Although it also assigned some of its engineers construction work, Taiwan Railways primarily provided the technicians and working labor for the project.³⁷ Taiwan Railways' report indicated that the electrification project was an unprecedented project and that it had neither the necessary experience nor engineers able to lead the project.³⁸ In the end, however, the electrification project was supposed to upgrade its traffic capacity by 50%,³⁹ but the result was only a 38% increase.⁴⁰

Some of the Taiwan Railways engineers described the electrification project as like trying to alter someone's clothes while she is walking.⁴¹ This metaphor also revealed that Taiwan Railways was the walking man who had little control over how to alter her clothes. However, after they had more opportunities to see and experience how foreigners made and adjusted their clothes, the Taiwan Railways engineers began to understand themselves better and even started picking up tools to design and improve their outfit. It looked like they learned when they followed and practiced. Moreover, as the hybrid locomotive example indicated, the Taiwan Railways engineers went further to create and make. Foreign technology transfer turned to become opportunities instead of constrains to local engineers. The more the technology flowed into Taiwan Railways the more resources in terms of knowledge and practice its engineers could apply to their work. This pattern of developing from clothing alternation to hybridization has emerged and later evolved to be a characteristic of Taiwanese engineering.

³⁶ *Ibid* and Taiwan Railways Administration, *Introduction to Taiwan Railways Administration*, 10.

³⁷ Taiwan Railways Administration, *General Report of the Electrification for the West Trunk Line*, 349.

³⁸ *Ibid*, 19.

³⁹ *Ibid*, 3.

⁴⁰ Taiwan Railways Administration, *Introduction to Taiwan Railways Administration*, 12.

⁴¹ Taiwan Railways Administration, *General Report of the Electrification for the West Trunk Line*, 31.

2.2.2 Early Railway Cannibalization Emerged and Spread to the Super Railway Project

The electrification project had some crucial impacts on Taiwan Railways' Super Railway Project. In its first report, the Super Railway Research team indicated that the Super Railway was viewed as the second important leap after Taiwan Railways' electrification project. These two steps of railway construction were to realize Dr. Sun Yat-sen's traffic advice for state building of the Republic of China.⁴² By introducing automatic train control (ATC) and central traffic control (CTC) systems to the electrified railways, running trains would still remain safe at speeds up to 250 km/h. One part of the Super Railway research thus was proposed to integrate the ATC and CTC systems into the electrified railway.⁴³ However, no further studies related to ATC and CTC were found in the Super Railway Research reports. Rather, the ways the Super Railway Research team conducted its research mainly highlighted the super railway's anticipated economic outcomes. It viewed the engineering research and development of HSR technologies as secondary to its economic effects in the very beginning. Although it mentioned those HSR technological designs for the future super railway's railroad, rolling stocks and power facilities, the Super Railway Research's first report primarily introduced the Shinkansen's and other foreign express railways' engineering specifications. Due to the Shinkansen's high quality performance in terms of speed, reliability and safety, the Super Railway Research team suggested Taiwan Railways to adopt the Shinkansen's engineering designs.⁴⁴

With references to the Shinkansen, the Super Railway Research team understood that the electrified West Trunk would be unable to run high speed trains even if it were equipped with the ATC and CTC systems. The West Trunk's narrow gauge and short curve radius, among other factors, would not allow high speed trains to run on it either. In addition, while the super railway

⁴² Taiwan Railways Administration, *The Year-1975 Work Report of the Research Project on the Development of Constructing Super Railway, Volume I*, 3-5.

⁴³ *Ibid.*, 5-6.

⁴⁴ See *Ibid.*

would be responsible for passenger commutes in the future, the West Trunk could focus on and promote even more freight transport than its current load. Super Railway Research team also indicated some exclusive advantages of building an independent super railway.⁴⁵ Therefore, the super railway was planned to own a new electrified railroad equipped with the ATC and CTC systems. Taiwan Railways' electrification project had provided them with some of the necessary experience to carry out its super railway project. However, as noted, Taiwan Railways did not play a leading role in the construction of its electrification project. Rather than attempting to develop HSR technologies by Taiwan Railways itself, the reports from the Super Railway Research team and its other publications in the *Taiwan Railways Journal* (台鐵資料) consistently show that their major research interests concerned the performance facts about the Japanese, French and German HSR technologies and how to adopt them in the future.⁴⁶

Most of the Super Railway Research team's first report was dedicated to Taiwan's socio-economic environmental analyses, the super railway's route design, and some estimation of Taiwan's future traffic demand and the super railway's traffic capacity. The following reports mainly followed the first report's framework and added more detail studies on these topics. Basically, they suggested that, according to their forecast of Taiwan's economic and population growth for fifteen to twenty years in the future, the transport infrastructure of the west Taiwan corridor would need to be significantly improved⁴⁷ in order to balance and promote Taiwan's social, economic, political, and land development. A new super railway would be a better option to achieve this developmental vision than other alternatives, such as another national highway or adding more tracks to the West Trunk, according to their cost-benefit analyses. Although those

⁴⁵ *Ibid*, 20~2.

⁴⁶ See the *Taiwan Railways Journal* from 1978 to 1992. Wen listed those HSR research papers, a total of 51, in the *Taiwan Railways Journal* and divided them into four groups: foreign HSR developments, HSR rolling stock and safety designs, HSR stations, routes and signaling systems, and the Taiwan HSR introductions and suggestions. See Wen, her footnote 34 on page 2-18.

⁴⁷ See Taiwan Railways Administration, *The Year-1975/76/78/81 Work Report of the Research Project on the Development of Constructing Super Railway, Volume I/II* (Taipei: Taiwan Railways Administration, 1975/76/78/81).

reports also introduced other foreign high speed or express railway services, the Tōkaidō Shinkansen's (東海新幹線; from Tokyo to Osaka, 515.4km) business records had been the Super Railway Research team's most important referential information for their argument making.⁴⁸ When the Super Railway Research submitted its first report to Taiwan Railways and MOTC in 1975, the Tōkaidō Shinkansen had been running for ten years. "Although the cost of the construction of the (Tōkaidō) line ended up being nearly double the amount initially forecast, the revenue from it had already surpassed this figure by the time the Sanyō Shinkansen (山陽新幹線; from Osaka to Fukuoka, 553.7km) opened (March 15, 1975)."⁴⁹ The Tōkaidō Shinkansen's business records regarding the amount of profit-making and traffic transport, among other things, impressed the Super Railway Research team.

The Super Railway Research team also devoted some effort to study the future super railway's mechanical, electrical and civil engineering. It conducted research on how to build an appropriate railroad on which different high speed trains, in terms of their original systems, could be allowed to run. The team was concerned with the engineering designs of the track gauge, the slope and radius curvatures, the track distance in between, the overhead contact systems, train outfits, the railroad's civil construction and so on. The team's reports clearly gave specific suggestions for the above designs, but most of them were not from engineering experiments. The Super Railway Research team mainly collected data about the Shinkansen and other express railways and compared and analyzed them with their engineering experience.⁵⁰ When the Super Railway Research team was working on its first report, the Sanyō Shinkansen was close to full completion. Because the Sanyō Shinkansen's performance was better than the Tōkaidō line because of its faster speed,⁵¹ it became the main source and reference of engineering designs for

⁴⁸ *Ibid.*

⁴⁹ Hood, 106

⁵⁰ See Taiwan Railways Administration, *The Year-1975/76/78/81 Work Report of the Research Project on the Development of Constructing Super Railway, Volume I/II.*

⁵¹ The Sanyō Shinkansen opened to traffic in 1975. Its maximum speed today is 30~50 km/h higher than that of

the Super Railway Research team later.⁵² Although Super Railway Research had included a more specific introduction of the French TGV and the U.K.'s HST (high speed train) to their reports, the Sanyō Shinkansen was still the engineering benchmark for Taiwan Railways' super railway designs.

2.3 Engineering Socialization of Early Cannibalization

As noted in the literature review of chapter one, the TGV was an unwanted child at its early stage and the Shinkansen might not have been created if there were no aircraft engineers transferred to Japan's railway industry after its defeat in World War II, among other factors. Both the TGV and Shinkansen's early histories showed that they were not their governments' intentions to develop or even to represent their countries' spirits. Those processes of their emergence were intertwined with some contingencies in terms of, for example, unpredictable domestic technology transfer, foreign competition, and the global energy crisis and so on. Likewise, the political and economic background of Taiwan Railways' electrification and Super Railway projects, as noted, had also shaped what the two projects looked like. Moreover, they even developed a different engineering trajectory for railway engineers in Taiwan.

Taiwan owned its first railway since 1887 and the railway engineers on the island of Taiwan, who belonged to any number of national identities including Chinese, Japanese, Taiwanese or new Taiwanese, have developed a localized way of understanding and practicing their railway engineering. Instead of viewing Taiwan railway's reliance on foreign technologies as a late coming countries' fate, this project intends to conceptualize it as a historical phenomenon. In other words, Taiwan railways engineers have devoted their expertise in a place that history has shaped. The ways Taiwan Railways implemented and planned its electrification project and Super Railway research have shown that Taiwan Railways engineers were

Tōkaidō Shinkansen. See Hood, 31 and appendix 3.

⁵² See Taiwan Railways Administration, *The Year-1975/76/78/81 Work Report of the Research Project on the Development of Constructing Super Railway, Volume I/II*.

experienced at and devoted their major efforts to repairing damaged facilities, maintaining obsolete systems, and incorporating different countries' equipment. Whether educated in China or the colonial Taiwan, they worked together for the miserable West Trunk and professionalized themselves in understanding each other's engineering knowledge.

The frail government of the Republic of China on Taiwan was surely unable to help its Taiwan Railways to develop railway technologies after World War II. Neither was the Taiwanese private sector able to do so after the Japanese left. Taiwan Railways even struggled over how to make its railways able to survive during the 1950s and 1960s.⁵³ In addition, the government of the Republic of China asked Taiwan Railways to finance its electrification project in the 1970s. Taiwan Railways was also forced to recruit unnecessary employees in order to settle down some immigrant mainlanders for the government.⁵⁴ Both policies have made Taiwan Railways' finances run in the red from the 1970s until now.⁵⁵ Thus, rather than advancing railway technologies, Taiwan Railways has struggled for its survival. However, this project intends to show that the way Taiwan Railways did its electrification project, Super Railway research and other earlier reconstruction projects has educated and developed its engineers' expertise at integrating different railway equipment and subsystems. Moreover, this development later contributed to shape a culture in which Taiwan Railways' engineers share a common knowledge of how to understand and practice their engineering jobs.

⁵³ See Kuomintang Central Committee of Design and Evaluation. Taiwan Railways Administration, *Introduction to Taiwan Railways Administration*. Also see So ed.

⁵⁴ I-Nan Hsu (徐亦南), "HSR Myth," *Taiwan Railways Journal* 260 (1989), 11.

⁵⁵ *Ibid*, 13

CHAPTER 3

TAIWAN HSR PROJECT'S ENGINEERING AND CONSTRUCTION PLANNING: CANNIBALIZATION, INTERNATIONAL COLLABORATION AND DESIGNING FOR INCLUSION

Although the HSR technology was about innovation, the story of how Taiwanese engineers transferred and adapted it was evolved from their earlier engineering experience regarding the railway upgrade projects. This chapter focuses on the second and third stages from 1973 to 1987 and from 1987 to 1996 in chart 1.1. The second stage was the period since Taiwan Railways initiated the Super Rail project until its abandonment. The third stage began from the point when the central government took over the Taiwan HSR project until it announced it would privatize the project. During these two stages, the government engineers gradually transformed their engineering knowledge and practice learned before the 1970s. They also acquired some leading power of making engineering specifications and designing construction plans. Some senior government engineers thus came to be able to express their ideas of how to build the Taiwan HSR project and conduct it with their career engineering experience.

However, the government engineers' professional knowledge and experience was insufficient to enable them to take the full responsibility to lead the Taiwan HSR project. Not only did they still have to rely on foreign consultant's professional planning, but some of their early hybrid engineering thoughts, such as building the best HSR in the world by integrating the three existing HSR technologies, were relatively simplistic and lacked of serious and detailed planning. The government engineers, nevertheless, had a chance to examine as well as develop their engineering experience through the project. After working on some planning projects with foreigners, the government engineers gradually scaled up their thinking of cannibalization to a more delicate and complicated engineering notion that I term hybrid engineering. The notion

included some specific engineering practices of learning through collaboration, designing for inclusion and managing for mediation etc. I discuss this notion in more detail in chapters five and six after investigating how Taiwan's international and identity politics in the second and third stages (from 1973 to 1996) produced impacts on the HSR project in chapter four.

3.1 From Early Cannibalization Experience to Collaborative Engineering Policy

After their trip to visit the French TGV and German ICE in 1990, the engineering team from the Provisional Engineering Office of the BOHSR (POHSR; 交通部高速鐵路工程局籌備處) affiliated with the MOTC, including its Director General Ping Tong *et al*, concluded that “For the purposes of operation and safety, we aim to develop our planning HSR to be the best one in the world by integrating all the advantages from Japan's Shinkansen, France's TGV and Germany's ICE HSRs.”¹ Tong did not reveal clearly why his team suggested this hybrid idea in their visiting report. Nor did he reply to this question to me directly in his interview. However, he told me a story from the Vietnam War,

I was a lieutenant general in the Combined Logistics Command of the Ministry of National Defense in the 1970s. At the time, the U.S. Army asked us to repair and maintain some of their damaged war crafts in Vietnam since it was located closer to Taiwan than to Japan and other U.S. territories. I was thinking, although we could not fix every damaged war craft, I believed that our engineers might be able to do things like returning one repaired craft with every two damaged-craft. Those Americans accepted our proposal because we were able to do this repair job quicker and cheaper than the Japanese or themselves in the U.S. In addition, they trusted us and certainly had dominant power over us in terms of international politics. We had to do it as best as we could. Besides, I had seen

¹ POHSR, *Visiting Report on the German and French HSR* (Taipei: POHSR, 1990), 42. The Bureau of High Speed Rail (BOHSR) was officially established on January 1997 while the POHSR (Provisional Engineering Office of High Speed Rail) was dissolved on the same day.

that our military engineers were quite creative and experienced at mixing subsystems or sub-equipments. They had been working in a very difficult and poor environment since the time they were in mainland China. This project might be able to help them accumulate more hybrid engineering experiences. I clearly knew what our engineers' expertise and experience were. I was one of them.²

Tong's response offers a historical vantage point to investigate those stories of the Taiwanese policy-makers and governmental engineers' simplistic intentions to construct the best HSR in Taiwan by integrating Japanese, French and German technologies. Tong *et al*'s engineering suggestions were not only based on their engineering knowledge, but also on their career experience. This career experience, as Tong revealed, has been intertwined with their socio-economic and political background.

It appeared that the Taiwan HSR planning project was independent from Taiwan Railways' Super Railway research in a manner where they were conducted by the different governmental institutes with different engineers at different time. These differences seemed to show an obvious and superficial break between them. Namely, it looked like the Taiwan HSR project inherited little from the Taiwan Railways' Super Railway research. The Super Railway was seen as out of date since it could offer little useful transport or engineering information for the central government's HSR project planning.³ However, this section shows that both the Taiwan Railways' Super Railway and MOTC's Taiwan HSR project followed a similar thinking/knowledge to practice their engineering planning.

² An Interview with Tong. Also see Chung-Yeh Tseng (曾瓊葉) ed., *The Vietnam War: An Oral History* (越戰回憶錄) (Taipei: Ministry of Defense Office of History, 2008), 315~58.

³ See the Legislative Yuan Gazette 75: 32 (1986): 58; 75: 103 (1986): 55; 75: 104 (1986): 106; 76: 50 (1987): 90; 76: 46 (1987): 133.

The Taiwan Railways' Super Railway research attracted no attention from the central government in the end. It submitted twelve mid-term reports during the 1970s and a final report in 1981 to the Provincial Government and MOTC of the central government.⁴ Taiwan Railways kept its expectations to build a super railway until the central government announced it would conduct a HSR feasibility study.⁵ When the Executive Yuan⁶ asked its MOTC and Provincial Government to conduct HSR research in 1987,⁷ this policy actually also implied that Taiwan Railways' Super Railway was abandoned. However, Taiwan Railways still tried to influence the MOTC's Taiwan HSR planning. Taiwan Railways sent its Director General and two senior engineers to visit the TGV and ICE in 1989. In their visiting report, they concluded that "our TGV and ICE visits would help Taiwan Railways to *develop* the Taiwan HSR in the future."⁸ The term "develop" here seemed to be an intentional use. Taiwan Railways might expect to either construct or operate, or to do both, in the future HSR project, even though it was not assigned to do the relevant planning. Taiwan Railways' superior agency, the Department of Transportation of Provincial Government, still claimed in 1990 that the Taiwan HSR would be one of the Provincial Government's eight future transport constructions in the 1990s.⁹

Although the MOTC's research team incorporated four Taiwan Railways engineers, they did not participate in Taiwan Railways' Super Railway research before. Wen thus claims that the professional knowledge for the MOTC's HSR planning project had significantly deviated from the Super Railway research.¹⁰ Nevertheless, Wen's assertion might underestimate Taiwan Railways' engineering socialization internalized into their engineers. As noted, although the

⁴ See Ling Hsu and Sun.

⁵ Chung-Ho Sun, 323.

⁶ The Executive Yuan is the highest administration agency in Taiwan. See its introduction "About Executive Yuan: History and Mission," <http://www.ey.gov.tw/ct.asp?xItem=52758&ctNode=1327&mp=11>

⁷ POHSR, *Engineering Plan for the High Speed Railway on the West Taiwan Corridor* (Taipei: POHSR, 1994), 1-1.

⁸ Taiwan Railways Administration, *Visiting Report on French, German, South Africa and Hong Kong Railways* (Taipei: Taiwan Railways Administration, 1989), 34.

⁹ See *Chinatimes*, "Provincial Government Planning HSR and Other Seven Transport Constructions," Jan. 31, 1990.

¹⁰ Wen, 2-26.

Taiwan Railways' Super Railway Research team was separated from its electrification project for the West Trunk, it inherited the West Trunk's engineering experience and shared some common engineering knowledge with other Taiwan Railways' engineers. The MOTC's Taiwan HSR project could never escape the Taiwan Railways' influence, even though it was implicit.

I argue that while Taiwan Railways has been one of the most important places conducting infrastructure-engineering in Taiwan, its engineering socialization was embedded within a broader picture that shapes a common knowledge among different engineering fields. In other words, the Taiwan HSR project has inherited a certain amount of Taiwan Railways' early engineering experience and knowledge. Furthermore, it has also generated Taiwan's engineering culture since Taiwan Railways has been one of the phenomenal engineering institutions in Taiwan.

Before the POHSR fully took over the Taiwan HSR project, the Institute of Transportation¹¹ under the MOTC was put in charge of the HSR project planning. Unlike the Super Railway, which was a provincial project, the HSR project was shifted from the local to the central government. This change not only demonstrated the central government's policy determination but also reflected social and political transformations during the late 1980s in Taiwan. I will discuss them in the following chapters, especially why the Super Railway research was abandoned and how this connected to the bigger picture in terms of the social and political background in the late 1980s and early 1990s in Taiwan. In addition, I will show how the Taiwan HSR project became like a proactive playground that stimulated several social and political changes. In this chapter, I stay focused on the Taiwan HSR project's early transport and engineering planning.

3.1.1 Leveling Cannibalization Experience Up to International Collaboration Policy

¹¹ Institute of Transportation was established on Jan 5, 1985. It was transferred from previous Committee of Transportation. See more its history "About IOT: Preface," <http://www.iot.gov.tw/english/ct.asp?xItem=380&CtNode=85>

Unlike Taiwan Railways, which organized an inner and local team to conduct the Super Railway research, the Institute of Transportation commissioned an international joint company of engineering consulting (the Am-Dec) to work with its HSR team. The team included engineers not only from the Institute of Transportation, but Taiwan Railways and another local engineering consulting company CECI.¹² This Institute of Transportation's outsourcing project was called the "West Taiwan High Speed Rail Feasibility Study (WT-HSR-FS)." The Am-Dec consisted of an American company PBI (Parsons Brinckerhoff International, Inc.) and a German company DEC (Deutsche Eisenbahn-Consulting GmbH). In addition, the Am-Dec also invited a U.K. financial consulting company, HFA (Halcrow Fox and Associates), to join them. As a result, the WT-HSR-FS project included eight professional institutes from four countries. Table 3.1 shows the number of engineers and professionals and what countries and firms they were from and what they did on the WT-HSR-FS team. CECI engineers and professionals composed the main body of the team. Compared with other functions, the Taiwanese engineers played a more important role of planning the HSR civil construction. This fits the general engineering phenomenon in Taiwan where civil engineering has been given more emphasis than other engineering fields in public projects. I argue that this phenomenon has been an outcome of Taiwan's engineering tradition of hybridity. I discuss and explain this in more detail in section two of chapter five.

According to Wen, the reason that the Am-Dec could acquire this WT-HSR-FS project was because the Executive Yuan's China-U.S. Fund (中美基金)¹³ provided most of its needed budget.¹⁴ In fact, the U.S. PBI had no HSR experience. Even though the Am-Dec incorporated

¹² Institute of Transportation, *West Taiwan High Speed Rail Feasibility Study, Final Report* (Taipei: Institute of Transportation, 1990), 1.

¹³ It was a fund with significant support from the U.S. Aid.

¹⁴ The government of Republic of China placed NT 90 millions for the WT-HSR-FS project, in which the China-U.S. Fund was responsible for NT 70 millions and the Taiwan Railways for the rest of 20 millions. See Wen, 2-32.

with the Germans, the German HSR system ICE was not in operation yet at the time.¹⁵ Wen thus claimed that the WT-HSR-FS project was an outcome of Taiwan's distorted international politics. In short, the U.S. had a dominant power over Taiwan. Wen also argued that, by applying Manuel Castells's insights about international technology transfer, those decisions about importing which foreign technologies for the non-advanced countries, like Taiwan, never just depended on professional knowledge only. The power of international politics always interjected itself and even took control over the process of international technology transfer.¹⁶

Table 3. 1 Professional Staff Distribution of the WT-HSR-FS Team

(used under fair use guidelines)

Function	Taiwanese Institutes			Foreign Consultants				Total	
	Ins. of Trans.	Taiwan Railways	CECI	PBI (U.S.)	DE-C (Germany)	Dornier (Germany)	HFA (U.K.)		
General Coordination	2	2	2	2	0.5*			8.5	14.91%
HSR System				1	0.5*	1		2.5	4.39%
Traffic Survey	1				1			2	3.51%
Urban Transportation	3.5*	1	3		7			14.5	25.44%
Civil Construction	2		3	1	2			8	14.04%
Budget Planning			2	1			3	3	5.26%
Financial & Economic Analyses	0.5*		1				2	4.5	7.89%
Environmental Engineering			2					4	7.02%
Cardiograph & Administrative Affairs			9	1				10	17.54%
Total	9	3	22	6	11	1	5	57	100%
	15.79%	5.26%	38.6%	10.53%	19.3%	1.75%	8.77%	100%	

* Each staff member with two professionals counts 0.5. Three Institute of Transportation engineers were excluded in the table because they participated in this project part-time.

Source: Wen, 2-29. Original Data Source: Institute of Transportation, *West Taiwan High Speed Rail Feasibility Study, Final Report*.

¹⁵ ICE was opened to traffic in 1992.

¹⁶ Wen, 2-31~33.

Another difference between Taiwan Railways and the Institute of Transportation's HSR projects was the latter's intentions to transfer foreign planning techniques to local engineering consultants through the WT-HSR-FS project. The Institute of Transportation invited French and Japanese HSR engineering consultants to work with CECI over there. They together organized the Department of Plan Management in the Institute of Transportation to manage and coordinate the WT-HSR-FS project.¹⁷ Thus, CECI not only cooperated with Am-Dec to conduct the WT-HSR-FS project, but also managed it in the Institute of Transportation with the French and Japanese HSR engineers. CECI was chosen to develop its HSR engineering profession by learning what HSR technologies existed at the time and, the more important, how to coordinate and check foreign technology transfer appropriately. CECI later played an important role assisting the POHSR/BOHSR, designing the THSR project's engineering specifications, and evaluating its engineering qualities.

The Institute of Transportation's policy of inviting the French and Japanese HSR consultants into the WT-HSR-FS project helped itself include all major HSR technologies. This incorporation policy made the Institute of Transportation escape from an unwanted monopoly that the Am-Dec might have favored or focused on the German ICE only. This policy, Wen argued, showed the Taiwanese technocrats' power of using their policy resources to resist interventions from international politics.¹⁸ Her perspective, she said, "discards the previous idea of looking at our technocrats' thinking of technology reliance from the pure technical or passive viewpoints."¹⁹ However, while Wen looked at this incorporation policy as a kind of resistance to the distorted consequences of international politics,²⁰ I want to argue that this policy was more like a product of the Taiwanese railway engineering socialization. My idea is not opposed to

¹⁷ Institute of Transportation, 1990, 3-4. The Department of Project Management consisted of the four units of transport planning, engineering support, economic analysis and administrative support.

¹⁸ Wen, 2-33.

¹⁹ *Ibid.*

²⁰ *Ibid.*

Wen's. Rather, it attempts to include and expand her argument by exploring the further question of where the Institute of Transportation's HSR technocrat's resistant abilities came from. With reference to Taiwan Railways' previous projects, we have seen that while Taiwan Railways' engineers were forced to import several advanced countries' systems and equipment, they developed their expertise by coordinating, practicing and evaluating them. Although they were unable to produce another HSR technology, Taiwan Railways' engineers were experienced at cannibalizing and hybridizing to some extent their conventional locomotives, track and rolling stock accessories and so on.

Taiwan Railways and the Institute of Transportation's research directions also characterized the third significant difference between their Super Railway research and the WT-HSR-FS project. While the latter focused more on HSR's transport planning, the former addressed railway engineering specifications more in its reports. Both studied Taiwan's socio-economic trends, transport capability at the time, possible alternative programs to alleviate the growing traffic, and then concluded that the super railway or HSR was an effective way of meeting Taiwan's future transport needs. However, Taiwan Railways devoted more effort to studying the super railway's engineering specifications, processes and civil constructions than the Institute of Transportation did.

First, the Super Railway Research team's first report indicated twenty three engineering specifications that they suggested should be adopted for their super railway, including three major engineering parts: the rolling stock, track design and power supply.²¹ According to this report, these engineering specifications came out after the Super Railway Research team compared Taiwan Railways' data regarding conventional railway with the Shinkansen and other foreign express railways'. Many of their suggestions were based on Taiwan Railways'

²¹ Taiwan Railways Administration, *The Year-1975 Work Report of the Research Project on the Development of Constructing Super Railway, Volume I*, 226~7.

electrification experience. As noted earlier, the Super Railway Research team was impressed by the Shinkansen's achievements. Therefore, they suggested adopting the Shinkansen's designs as long as there would be no conflict with Taiwan Railways' electrification experience. In short, Taiwan Railways' Super Railway Research planned many more detailed engineering specifications than the Institute of Transportation's WT-HSR-FS in their reports. This was mainly because Taiwan Railways brought its own engineering data and experience with conventional railways into their Super Railway research. While Taiwan Railways compared the HSR engineering specifications with its conventional experience, the Institute of Transportation's report only showed the engineering differences among the Japanese Shinkansen, French TGV and German ICE.

Second, unlike the Institute of Transportation's WT-HSR-FS report, Taiwan Railways' reports displayed their additional engineering interests about making engineering specifications. In their second report, the Super Railway Research team formulated mathematical functions for the minimum horizontal radius, vertical and spiral curves and slope grades for high speed trains. They not only introduced the Shinkansen's and other express railways' engineering data, but also simulated how their parameters were calculated.²² As noted, the Super Railway Research team referred their parameters and data to the Shinkansen, but they also put their engineering experience into their engineering calculations. However, the Institute of Transportation's WT-HSR-FS report revealed no research on the engineering formulation and calculation.

Third, in its 1968 report, the Super Railway Research team provided their research on how to practice civil construction for their super railway.²³ They even sent a field unit to collect and survey the mountains and common alignments' geographic and geological data along the 94 km

²² Taiwan Railways Administration, *The Year-1975 Work Report of the Research Project on the Development of Constructing Super Railway, Volume II*, 94~125.

²³ See Taiwan Railways Administration, *The Year-1978 Work Report of the Research Project on the Development of Constructing Super Railway, Volume II*.

from Keelung to Longtan (龍潭) in northern Taiwan.²⁴ This survey unit investigated the field data and then designed a detailed route that fit the engineering specifications they had suggested in 1965. Moreover, they even planned how to build the super railway's roadbed on the bridges and other special geologic features with different soil types. In the end of the report, the field survey unit offered very detailed construction specifications. The engineering data in the 1968 report revealed Taiwan Railways' abundant engineering experience and knowledge regarding railroad constructions that they had accumulated after the Japanese left in 1945. However, on the other side, the Institute of Transportation's WT-HSR-FS report showed no study of those construction specifications and field data for their railroad designs. Although the Institute of Transportation arranged its WT-HSR-FS project with a focus more on transport studies than railway engineering, the WT-HSR-FS report seemed to create a trend that shaped later HSR project planning along similar directions.

The last but not the least difference concerned the route design factors. Taiwan Railways' Super Railway Research team listed eleven general factors in order of importance for their alignment design: national defense, domestic geo-politics, economic development, cultural development, geological environment, route design engineering, environmental impacts, business operation, land use and development, traffic coordination with the Taiwan Railways, and cost-benefit ratio.²⁵ On the other side, the Institute of Transportation's WT-HSR-FS was concerned with, in order of importance, the transport effects, construction cost, social and natural environmental impacts, rural development, minimum land use, the safety along the route, landscape fitness, and cost-benefit ration.²⁶ The major difference between Taiwan Railways' Super Railway research and the Institute of Transportation's WT-HSR-FS project was the former

²⁴ *Ibid*, appendix, 1.

²⁵ Taiwan Railways Administration, *The Year-1976 Work Report of the Research Project on the Development of Constructing Super Railway, Volume II*, 10~3.

²⁶ Institute of Transportation, *West Taiwan High Speed Rail Feasibility Study, Final Report*, 105~6.

listed national defense and even put it as the most important one. Other than that, both reports' route design considerations were similar. Thus, both reports suggested the government should choose a mountain alignment rather than the coast and central alignments. However, since Taiwan Railways included the factor of national defense in their considerations and even gave it priority, this implied that the backgrounds behind the two projects had changed. I will discuss this more in the following chapters.

Although the Institute of Transportation's report had less detail on engineering specifications than Taiwan Railways' Super Railway research did, it had more various analyses on HSR core systems than the Taiwan Railways' research. The Institute of Transportation's report included information on the German ICE and maglev-train systems as well as some HSR technological comparisons with the French TGV that Taiwan Railways' research did not have. It was because the German ICE and maglev-train systems appeared in the late 1980s and the TGV began its business operation in 1981 but the Taiwan Railways had already conducted its Super Railway research from 1974 to 1981. In its report, the Institute of Transportation suggested the steel-wheel HSR system be adopted mainly because, among other things, the maglev HSR was not mature yet.²⁷ However, since the Shinkansen, TGV and ICE were all qualified and had their different technological advantages, the Institute of Transportation did not reveal a preference for adopting one in particular for the Taiwan HSR in its WT-HSR-FS final report.

3.1.2 Merging Early Cannibalization Experience with International Collaboration Policy

After fourteen months the Am-Dec, CECI and Institute of Transportation coproduced their WT-HSR-FS final report and the MOTC submitted it to the Executive Yuan in March 1990. One month later the Executive Yuan approved the final report's conclusion of the necessity to build a HSR along the west Taiwan corridor. It also soon granted its MOTC to establish the

²⁷ *Ibid*, 44

POHSR in June. Taiwan Railways thus finally lost its opportunity to implement the HSR construction, but the Executive Yuan remained open regarding who should run and how to run the Taiwan HSR after its completion. Taiwan Railways was not excluded from the whole Taiwan HSR project yet.

The POHSR was soon established and began to run business within one month. Unlike the long period of fifteen years from 1973 to 1987 that passed while Taiwan Railways conducted its Super Railway research and waited for the Executive Yuan's substantial response, the MOTC got the Executive Yuan's reply and earned its permission to build a HSR within just only four years, from 1987 to 1990. It seems that one of the major factors that made this difference was that it was the Provincial Government that suggested its Taiwan Railways conduct the Super Railway research, while the MOTC's HSR feasibility study was initiated by the Executive Yuan. The Provincial Government was a local government that had much less power than the Executive Yuan, which has been the highest administration in Taiwan since the end of World War II. Wen made this argument,²⁸ but she might have overlooked some other significant political factors. I argue it was nothing but political determination to realize this HSR policy. As noted, I will discuss those significant changes of social and political background during the period from 1987 to 1990 that scaled up the government's determination on its HSR policy in the following chapters.

The POHSR took over the Institute of Transportation's HSR planning in 1990, but it followed its policy-planning line. Soon after its establishment, the POHSR respectively invited the Japanese JART-HSR, French SOFRERAIL and German DE-Consult to bid on its general contract for the Taiwan HSR engineering consultant. This contract required the winner to cooperate with a local joint team.²⁹ In addition, the two losing bidders would be invited by the

²⁸ Wen, 2-24.

²⁹ POHSR, *West Taiwan High Speed Rail General Planning, Final Report* (Taipei: POHSR, 1991), 1-1.

POHSR to be their special engineering consultants. The POHSR “aimed to build a first class HSR in the world in the sense that the Taiwan HSR will assimilate the best technologies in different HSR systems while it would not be controlled by any specific HSR technology.”³⁰ French SOFRERAIL won the contract in the end, and the Japanese JART-HSR and German DE-Consult became the POHSR’s special engineering consultants. According to the contract, in addition, SOFRERAIL had to hire 30% of its manpower from Taiwan engineering consultant companies.³¹ This POHSR policy was very similar to the Institute of Transportation’s WT-HSR-FS in that, firstly, they commissioned foreign engineering consultants, secondly, they required the winner to work with local consultants by which not only could the commissioned foreign consultant understand Taiwan’s engineering environment soon but local engineers could learn technology through collaboration, and finally they invited the losing bidders to join their HSR planning work. Both the Institute of Transportation and POHSR’s planning arrangements showed their intentions of hybridizing advantages from existing HSR technologies.

The MOTC wanted to learn about HSR from foreign consultants, but during the period from its WT-HSR-FS report approved by the Executive Yuan in April until the POHSR’s contract with SOFRERAIL in October 1990 they did not learn what they expected. During this six month period, the MOTC sent its engineers along with some others from its Institute of Transportation, Railway Reconstruction and Taiwan Railways to visit the Shinkansen, TGV and ICE. Railway Reconstruction was the general staff for the POHSR before its establishment, and its Director General, Ping Tong, was arranged by the MOTC to take over the POHSR in the beginning. Tong also served as Taiwan Railways’ Director General before his service in the POHSR and Railway Reconstruction. He was assigned by the MOTC to lead its engineers to visit the Shinkansen, TGV and ICE.

³⁰ *Ibid.*

³¹ *Ibid.*, 1-4.

Tong's visiting reports were crucial because, firstly, they showed the local engineers' perspectives regarding foreign HSR systems, and secondly, they revealed that Tong brought some of his previous cannibalization experiences into the POHSR. The first trip of Tong's HSR visiting team was to Japan. In the conclusion of their report, they divided the whole Taiwan HSR project into four stages: the feasibility study, general planning, detailed design, and civil construction. At that time, the project was located in the stages between the feasibility study and general planning. Because Taiwan Railways and Railway Reconstruction had acquired fruitful experience regarding railway construction, they claimed that the HSR project's general planning and detailed design were more important stages than its civil construction.³² In addition, they also suggested the future Taiwan HSR should adopt Taiwan Railways' electrification standards for its power supply system.³³ Although Taiwan Railways, as noted, was excluded from the HSR project until the completion of its construction, it still passed some of its engineering experience on to the Taiwan HSR project through its engineers.

Tong's Shinkansen visiting report showed no further engineering interest in exploring the Shinkansen technology. Even though this report mentioned several of the Shinkansen's important engineering specifications, the visiting team did not express their intentions to explore those engineering theories and formulations behind those data. In the rest of their suggestions, they outlined several planning principles for future Taiwan HSR's subsystems, including the rolling stock, signaling system, track style, and so on.³⁴ Therefore, this report revealed that they intended to have those foreign HSR engineering consultants do both general planning and detailed designs for the Taiwan HSR, but these engineering planning and designs should be grouped into a few units of subsystems.

³² Railway Reconstruction Bureau, *Railway Reconstruction, Visiting Report on the Japanese Shinkansen: Planning, Design, Build and Operation* (Taipei: Railway Reconstruction Bureau, 1990), 83.

³³ *Ibid*, 92.

³⁴ See *ibid*, 83~94.

In other words, the MOTC required the foreign HSR consultants to complete the planning and designs according to the POHSR's general specifications that they had developed from their HSR trips or their own studies. For example, in their Shinkansen report, Tong's team suggested duo steel wheels with rubber-pads should be used on the Taiwan HSR's rolling stock.³⁵ Actually it was the German ICE's technology; neither the Shinkansen nor the TGV's rolling stock was equipped with it. Because the Shinkansen report was done in September 1990 after Tong's second HSR trip to France and Germany in July, it is likely that Tong wrote his ICE experience in his Shinkansen report. The point here is that Tong experienced the advantages of the duo steel wheels with rubber-pads, so he suggested that they should be equipped on the Taiwan HSR's rolling stock. Even though the Taiwan HSR might mainly adopt the Shinkansen's rolling stock system in the future, the steel wheels of its rolling stock still needed be put on rubber-pads.

As noted at the beginning of this chapter, after he began his service in the POHSR and his trips to France and Germany in July 1990, Tong's HSR team suggested that the POHSR's Taiwan HSR planning should integrate the different advantages from the Shinkansen, TGV and ICE in order to make the Taiwan HSR the best HSR system in the world. Besides the above statement, they also made four other suggestions at the time. First, the Taiwan HSR should pay attention on HSR technologies' future developments and their maturity in terms of reliabilities, developments and advancements of technologies. Second, the HSR's planning for civil construction should be more important than the adoption of rolling stock systems, because it would cost about 50% to 60% of the whole HSR budget, which was much higher than that of rolling stock. Third, although it would be the safest and most convenient way for Taiwan to adopt a single system, the POHSR should still conduct more research on the relations among HSR technologies' different subsystems. By doing so, the government would have some

³⁵ *Ibid*, 89.

flexibility of decision-making on the adoption of the HSR core technologies. Four, Taiwan HSR should not only be a transport tool but also a national construction project to balance our territorial development and an opportunity to advance our progress in engineering, technology and even industrial development.³⁶

Within a few months, as a result, the POHSR's intentions to hybridize the Shinkansen, TGV and ICE appeared much clearer in its TGV and ICE report than it did in the Shinkansen report. It had gradually built its engineering specifications and other relevant considerations for the Taiwan HSR. The POHSR would be responsible for setting up the Taiwan HSR's general engineering specifications and assuring that the future foreign HSR consultants' detailed designs would be able to satisfy them. By doing so, the POHSR attempted to bring Taiwan the best HSR system in the world in terms of incorporating those different advantages from the Shinkansen, TGV and ICE. However, this engineering hybridization excluded one part, Taiwan HSR's civil construction. The POHSR recognized that Taiwan Railways and Railway Reconstruction could offer their civil railway experience to the Taiwan HSR construction. Their engineers were included to build the Taiwan HSR together. The local railway engineering knowledge and experience therefore remained.

3.2 Early Engineering Culture of Hybridity: Designing for Inclusion

After the POHSR became more prepared through its efforts to understand the Shinkansen, TGV and ICE,³⁷ it contracted with the French SOFRERAIL for Taiwan HSR's general planning in October 1990. The SOFRERAIL team incorporated 30% of its manpower from six Taiwanese engineering consult companies.³⁸ The POHSR also invited the Japanese JART-HSR and

³⁶ POHSR, *Visiting Report on the German and French HSRs*, 42~3.

³⁷ In addition to sending local engineers to visit the Shinkansen, TGV and ICE, the POHSR also invited them to give some public presentations in Taiwan for five days respectively. See Shen-Long Hsu (許盛隆), "Mr. Tong Ping's Career: From Military to Engineering Service," *Journal of Chinese Engineers* (2004). www.c-km.org.tw/people/9312.pdf

³⁸ These six local engineering consulting companies were the CECI (中華), Sinotech (中興), CTCI (中鼎), Pacific Engineers & Constructors (泰興), MAA (亞新) and T. Y. Lin (林同棧). POHSR, *West Taiwan High Speed Rail*

German DE-Consult to be their special HSR engineering consultants. In addition, the POHSR also allowed the congress, interest groups and other governmental agencies to participate in their HSR planning project. This implied the project involved more and more politics. Figure 3.1 shows the management framework for this Taiwan HSR planning project. In October 1991, the POHSR completed its final report on the *West Taiwan High Speed Rail General Planning* (WT-HSR-GP) after incorporating the SOFRERAIL team’s report, its special consultants’ advice and the Executive Yuan’s comments from earlier in June. Although the mid-term report confronted some challenges from the Executive Yuan, as the following paragraph will show, the Executive Yuan soon approved the final report and announced it would include the Taiwan HSR construction plan into its policy for the fiscal year 1992 to be submitted to the Legislative Yuan.³⁹ The Taiwan HSR project then was able to enter into the third stage of detailed design.⁴⁰

Figure 3. 1 Taiwan HSR Planning Management Framework in WT-HSR-GP (public domain)

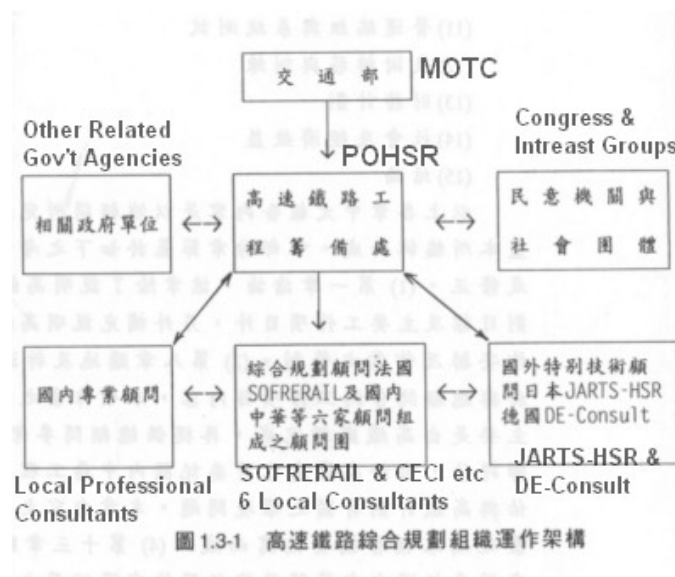

Source: POHSR, *West Taiwan High Speed Rail General Planning, Final Report*, 1-5.

General Planning, Final Report, 1-1.

³⁹ POHSR, *West Taiwan High Speed Rail General Planning, Final Report*, 1-1~2.

⁴⁰ *Ibid*, 1-3.

In addition to the HSR planning goals of traffic alleviation and economic growth that were listed in the Institute of Transportation's WT-HSR-FS and Taiwan Railways' Super Railway reports, the POHSR's WT-HSR-GP report went further in expecting that "the Taiwan HSR would represent a developmental milestone for the Taiwanese that their country will become one of the advanced countries in the world after its completion."⁴¹ This statement implied the presence of and introduced even more politics into the Taiwan HSR project. The Taiwan HSR was viewed as a turning point that would mean the Taiwanese could no longer feel that their homeland was always lagging behind the developed countries. However, this had more to do with political leaders' visions than with technocrats' intentions. This political development could be detected in the process of the Taiwan HSR project's general planning. Before their submission of the final report to the Executive Yuan, the POHSR and MOTC presented their mid-term work report to premier Pei-tsun Hau (郝柏村) of the Executive Yuan in June 1991. Hau asked the MOTC to view the Taiwan HSR not just as a transport construction but as an important infrastructure for our national development. Minister of the MOTC, Eugene You-hsin Chien (簡又新), rephrased Hau's advice that "our decision-making process for future transport planning should be top-down instead of bottom-up. The transport policy should take more responsibilities for national development than traffic alleviation."⁴²

Therefore, the Taiwan HSR project was politically planned to play a core role in the Hau's Six-Year National Development Plan (6-Year Plan; 六年國建計畫).⁴³ This project intended to bring Taiwan into a new developmental era in terms of catching up with more advanced countries. As a result, the POHSR and MOTC changed their recommended HSR route from the mountain to the second coast alignment. Rather than its transport capability, the WT-HSR-GP

⁴¹ *Ibid.*

⁴² See *United News*, "Important Transport Construction Planning Should be Made Top-down," June 23, 1991. Also see *United News*, "Hau: HSR Planning Design from Viewpoints of National Planning and New City-town Development," June 22, 1991. Hau's interview was on Public Television Service on Dec. 5, 1992.

⁴³ See more in chapter 5.

report addressed more the issue of how the design of the location of the stations and the alignment of Taiwan HSR would contribute to Taiwan's national development in terms of distributing economic and population growth to the whole west corridor. The WT-HSR-GP report had mixed its transport planning with political visions of what the development of the Taiwanese community will be in the future. I leave this issue of the connection between Taiwanese politics transformation and the Taiwan HSR project in the next chapter, and remain focused on the WT-HSR-GP report's engineering planning in this section.

Technically, the WT-HSR-GP report reviewed the POHSR's general engineering specifications, which they learned and developed from (1) their cooperation with the SOFRERAIL team, JARTS-HSR and DE-Consult; (2) their visits to Japan, France and Germany; and (3) those presentations given by the Shinkansen, TGV and ICE. This report also showed that the POHSR established some new engineering specifications in order to be compatible with the advice offered by the foreign HSR consultants. It respectively discussed those specifications in the Taiwan HSR system's eight engineering subsystems.⁴⁴ In addition, the POHSR reevaluated their general engineering specifications. It gave up some of their original thoughts and reorganized some others for their future HSR construction. Although the SOFRERAIL team was the POHSR's general HSR consultant, the POHSR's intentions had been to review the SOFRERAIL team's work and reset its original engineering specifications for the Taiwan HSR project.

The WT-HSR-GP report indicated that the rolling stock, catenary (overhead contact system) and signaling systems were the three core engineering subsystems in the HSR electrical and mechanical system.⁴⁵ In the report, the POHSR reviewed their original engineering idea that the Taiwan HSR might be able to incorporate these three subsystems from three different

⁴⁴ See POHSR, *West Taiwan High Speed Rail General Planning, Final Report*, chapter 5.

⁴⁵ *Ibid*, 5-5.

countries.⁴⁶ In Tong's interview, he also revealed his idea of integrating these three core subsystems to make the Taiwan HSR perform better than any others.⁴⁷ However, the POHSR realized this "divided procurement" would place the responsibility of subsystems' coordination on the buyer. In other words, the POHSR would need to be responsible for the integrated system's performance if these subsystems were integrated from different HSR systems. In addition, the POHSR also found that the construction work of Taiwan HSR might be delayed and even lead to an unexpected increase in cost if they decided to proceed with a divided procurement. Figure 3.2 shows those eight subsystems and their relationship in the HSR electrical and mechanical system. They had three different levels of relations in term of complication among them. Among others, the rolling stock subsystem was seen as the most important because almost all the rest of the subsystems directly connected to it. In addition, it and the catenary and signaling subsystems were considered to be connected with highly complicated interfacial designs.

On the other hand, in the WT-HSR-GP report the POHSR indicated that the responsibility for the core subsystems' coordination could be switched to the suppliers if the POHSR would adopt an "integrated procurement" to build the Taiwan HSR's core system. The integrated procurement referred to the acquisition of an intact system that already included all three core subsystems. This strategy, the POHSR claimed, should be less complicated, risky and costly than to adopt a "divided procurement" for the Taiwan HSR's core system. Thus, the POHSR suggested that the Taiwan HSR purchase an integrated core system as long as its rolling stock could reach its business speed of up to 300 km/hr.⁴⁸ The POHSR, nevertheless, did not designate at the time which existing HSR core system, the Shinkansen, TGV or ICE, they were going to adopt for the Taiwan HSR.

⁴⁶ *Ibid.*

⁴⁷ An interview with Tong.

⁴⁸ POHSR, *West Taiwan High Speed Rail General Planning, Final Report*, 5-6.

Figure 3. 2 HSR Subsystem Relationships (public domain)

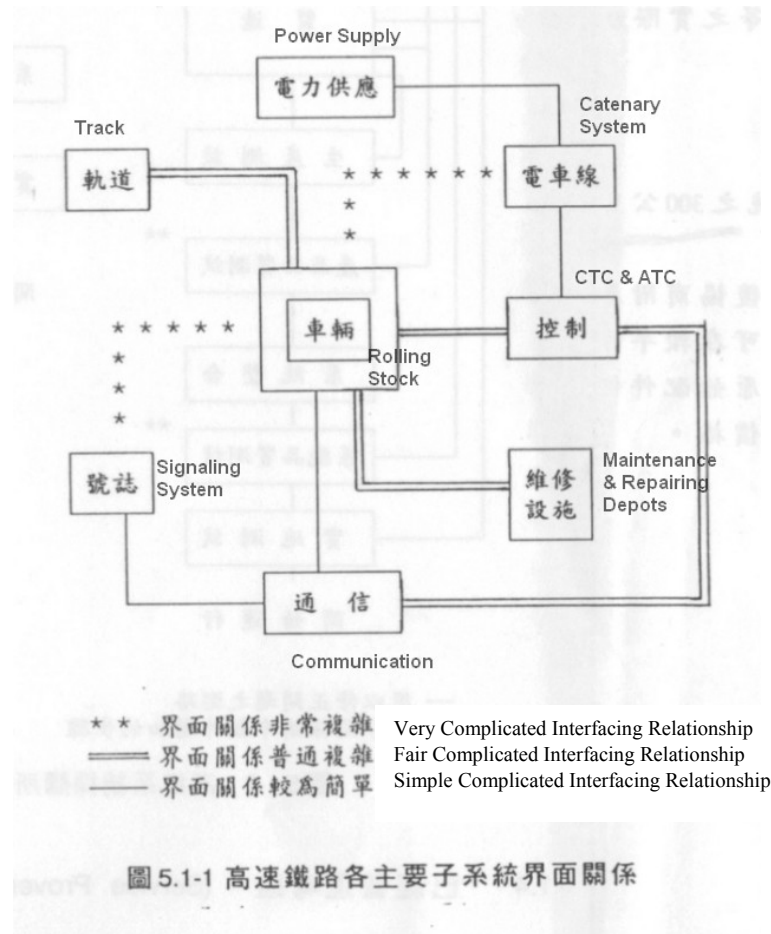

Source: POHSR, *West Taiwan High Speed Rail General Planning, Final Report*, 5-4.

The POHSR added some more general engineering specifications especially to the Taiwan HSR's core subsystems in the WT-HSR-GP report. In addition, they were more specific than those in the WT-HSR-FS report as well. The POHSR indicated that these “engineering and functional specifications making were based on the Japanese, French and German experiences, and Taiwan’s special needs.”⁴⁹ In other words, all of the JART-HSR, SOFRERAIL and DE-Consult would be qualified to make a HSR system that would satisfy the POHSR’s engineering requirements. The POHSR did not denote what the decisive points were to win the contract of

⁴⁹ *Ibid*, 5-41.

the Taiwan HSR core system, but its report mentioned that any HSR bidder could take advantage if its system met the condition of “operating service proven” established by the POHSR.

The POHSR divided the idea of service proven into three stages of the “component service proven,” “technical service proven” and “operating service proven.” First, the so-called “component service proven” was intended to assure that any subsystem could work with any other HSR core systems’ subsystems. According to the conclusion in the WT-HSR-GP report, there had been no universal proven component in the HSR core systems, thus this condition indirectly strengthened the POHSR’s earlier suggestion of adopting an integrated core system instead of a “patchwork system.” Second, the “technical service proven” referred to a HSR core system’s test performance without serious problems. A HSR core system with the technical service proven could show its test data matching with its theoretical data. Finally, if a HSR core system had been operating service proven, its business performance should be as reliable as its test and theoretical performance. This business performance referred to the “long term operation,” which meant the HSR system should have been significantly revised, tested and assured in its original country rather than being concerned with how many hours, days, months or kilometers of its operation there were.⁵⁰

Even though the POHSR added this new consideration of service proven to facilitate its decision-making in choosing which core system the Taiwan HSR would adopt, this still was not very helpful for them in making the final decision of choosing among the Shinkansen, TGV and ICE. Although the ICE just started its business operation in 1991, it had accumulated the needed experience and assured its performance quality was similar with the Shinkansen and TGV. Moreover, the POHSR realized that HSR technologies were improving over time. Therefore, the German ICE might even have some advantages over the other two. For example, as noted, its

⁵⁰ *Ibid*, 5-8~9.

duo steel wheels with rubber-pads could strengthen its rolling stock's running stability and reduce its noise significantly. Those Japanese, French and German HSR bidders, thus, still showed great confidence and interest in selling their core systems to Taiwan.

It appeared that the process of selecting which foreign core system for the Taiwan HSR had not been changed much after the POHSR completed its WT-HSR-GP report. However, the POHSR became more conservative in terms of its willingness to integrate the three different HSR core subsystems. "A patchwork system was not acceptable for the Taiwan HSR."⁵¹ One thing worth noting was that Tong left the POHSR one month before it submitted the WT-HSR-GP report to the Executive Yuan in October 1991. Unlike Tong's original engineering idea, the Taiwan HSR seemed unlikely to adopt different subsystems for its core system since then. Tong's departure might enhance the POHSR's conservatism. Nevertheless, in the end the completed THSR's rolling stock and signaling subsystems in 2007 came from the Japanese and European designs respectively. It was not surprising that politics intervened, but the more surprising phenomenon I want to address here is that it was Taiwanese engineers that made it possible.

Except for those three core subsystems, the other five subsystems shown in Figure 3.2 were allowed to be acquired separately from the different foreign HSR systems. Because the POHSR concluded that these secondary subsystems connected to each other with fair or simple relations, their engineering specifications and interfacial relations were easier to integrate than the core subsystems.⁵² In the WT-HSR-GP report, the POHSR set up some general engineering specifications in terms of numbers and contents. These specifications, as the POHSR indicated, were mainly based on the (1) foreign consultants' advice, (2) some of the latest HSR technologies at the time, and (3) Taiwan's existing infrastructure specifications.⁵³ For example,

⁵¹ *Ibid*, 5-8.

⁵² *Ibid*, 5-41.

⁵³ See *Ibid*, chapter 5.

the Taiwan HSR's communication subsystem was planned to apply optical fiber cables, which was a new technology at the time, to transmit its operating information. As with its power supply subsystem, the POHSR attempted to use Taiwan Power's existing unit of electricity frequency of 60 Hz for Taiwan HSR's rolling stock instead of 50 Hz, which most of the HSR systems adopted.⁵⁴ However, the POHSR accepted the foreign consultants' advice to build two power supply lines with 25,000 volts.

The POHSR devoted a chapter to study Taiwan HSR's structural construction in the WT-HSR-GP report. Like the WT-HSR-FS report, the WT-HSR-GP also proposed to build most of the Taiwan HSR railroad on the aerial structure. They suggested the ratio of its aerial structure should be from 55.6% to 68.7%.⁵⁵ Therefore, a portion of the chapter discussed the designs of viaducts and river bridges for the Shinkansen, TGV and ICE. Contrary to its open decision of adopting core subsystems, the POHSR clearly recommended the application of the French design mainly because it displayed a better structural strength against earthquakes than the other two. In addition, the French aerial structure had advantages in terms of building efficiency. It required a shorter construction time and less cost than the other two HSR structures.⁵⁶ This suggestion led to some of the most controversial problems later when the THSRC switched to adopt the Shinkansen core system in 2000. This was mainly because the Japanese claimed its Shinkansen was the only HSR system running along an earthquake belt. However, their Shinkansen rolling stock was planned to run on the French-design aerial structure in Taiwan. The Japanese were very worried the THSR could not maintain their record of zero accidents caused by earthquakes. Basically, the WT-HSR-GP offered more detailed civil designs than the WT-HSR-FS. For example, it indicated three different pillar designs (Figure 3.5) and preferred to adopt the TGV design. However, the WT-HSR-GP made a different set of designs rather than following and

⁵⁴ *Ibid*, 5-25.

⁵⁵ *Ibid*, 6-41 and Institute of Transportation, *West Taiwan High Speed Rail Feasibility Study, Final Report*, 32.

⁵⁶ POHSR, *West Taiwan High Speed Rail General Planning, Final Report*, 6-41.

entailing the designs of the WT-HSR-FS. For example, Figure 3.3, 3.4 and 3.6 show the HSR viaduct structure designs in the WT-HSR-FS and WT-HSR-GP reports. The WT-HSR-GP showed a wider viaduct design and its design of precast structure was different from both designs of the river and viaduct bridges of the WT-HSR-FS. The WT-HSR-GP did not cite the WT-HSR-FS’s designs of aerial structure. Unfortunately, this seems to be an inevitable phenomenon shaped by the earlier engineering culture, as noted previously, where Taiwanese engineers conducted their project in such a way as altering someone’s clothes while she was walking.

Figure 3. 3 Typical Section HSR River Bridge Figure 3. 4 Typical Section HSR Viaduct Bridge (WT-HSR-FS) (public domain)

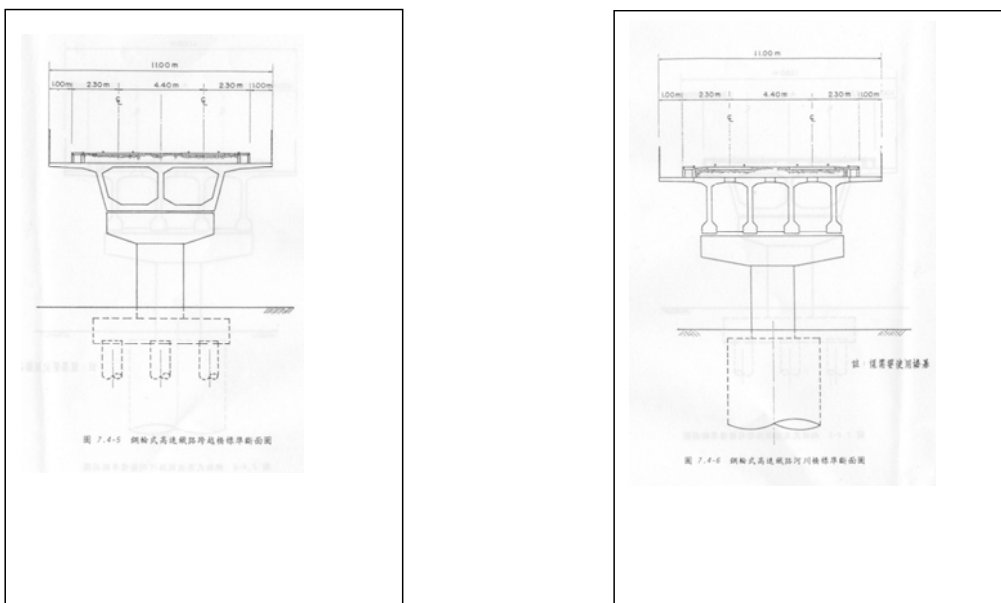

Source: Institute of Transportation, *West Taiwan High Speed Rail Feasibility Study, Final Report*, 97~8.

In sum, although the POHSR still kept its intentions to hybridize some of the different HSR technologies’ subsystems, it became more conservative about Taiwan HSR’s “core” subsystems than the Institute of Transportation was. Tong’s original thought on the hybrid core subsystems had disappeared. However, as noted, the completed THSR’s three core subsystems in 2007 are

not from a single integrated engineering design. While its rolling stock is imported from Japan, the THSR's signaling subsystem applies the European design. Social and political changes in Taiwan after the WY-HSR-GP report in 1991 caused the Taiwan HSR planning process to turn to another scenario. Although the Executive Yuan approved the WT-HSR-GP report, the Taiwan HSR planning process had not really settled down at that time. The WT-HSR-GP report drew more of the Taiwanese attention to Taiwan HSR's financial planning than to its core subsystems and construction planning. Taiwanese society worried about whether they could afford to build such an expensive infrastructure and asked its government to check its budget plan more seriously. This social response not only later changed Taiwan HSR's financial planning, but also produced some important impacts on its core subsystem planning. The THSR's engineering and construction planning thus went into another scenario. Since it is the main theme of this chapter, I will remain focused on the engineering and construction planning in the next section. I will discuss those social and political changes, the responses to them and the engineering and construction practices together in the following chapters.

Figure 3. 5 HSR Aerial Structure Types (WT-HSR-GP) (public domain)

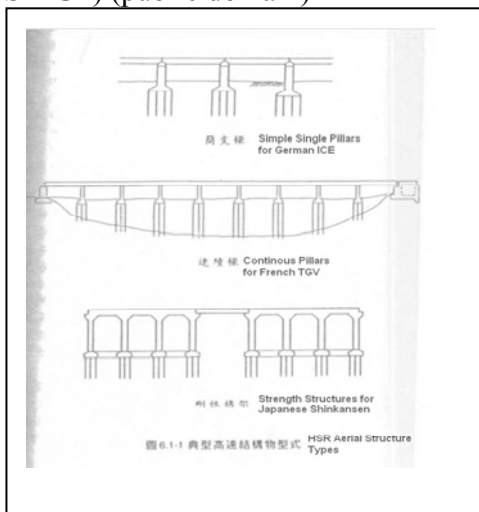
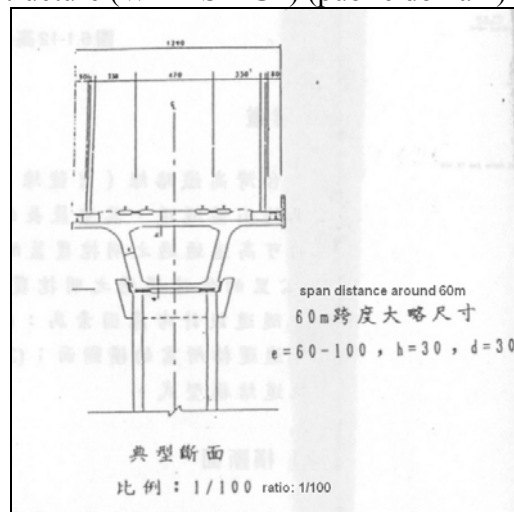

Figure 3. 6 Typical Section of French TGV Aerial Structure (WT-HSR-GP) (public domain)



Source: POHSR, *West Taiwan High Speed Rail General Planning, Final Report*, 6-3, 16.

3.3 Engineering Experience and Policy of Hybridity Emerged

Taiwan HSR's financial planning brought the whole project, including its engineering and construction planning, into another unforeseen scenario in the early 1990s. The government had shown its concerns about Taiwan HSR's financial planning as early as when the WT-HSR-FS report was approved in 1990. The Executive Yuan was very cautious about this immense expenditure, but its attitude toward building a HSR was positive and confident.⁵⁷ At the time, Taiwanese society and its congress, the Legislative Yuan, were not very aware of the financial issue. However, the WT-HSR-GP report raised many more financial debates regarding the immense cost of the Taiwan HSR's construction than had arisen before. Not only did Taiwanese society wonder if they could afford a HSR, but also the Ministry of Finance under the Executive Yuan expressed serious worries that this project might produce a huge burden for the government immediately.⁵⁸ Therefore, after the Executive Yuan approved the WT-HSR-GP report in 1991, the POHSR was soon under heavy pressure and received numerous questions from the Taiwanese public, congress and even other governmental agencies. It then was forced to look to Taiwan's private sector to invest in its Taiwan HSR construction and operation. Most of the content of the POHSR's *Taiwan HSR Construction Plan*, therefore, was devoted to answering those financial doubts and how to attract private sector investment.⁵⁹ Finally, the Executive Yuan decided to realize its Taiwan HSR project with the format of BOT in the end of

⁵⁷ See *Economic Daily News*, "Council of Economic Planning and Development Agrees the Taiwan HSR Project," Mar. 1, 1990.

⁵⁸ See *United News*, "Chien (簡又新; Minister of MOTC): Money First for All Transport Constructions," May 30, 1991; "Wang (王建煊; Minister of Ministry of Finance): No Money Fact, HSR for Private Investments," June 5, 1991; "CEDP V.S. MOF for Money," June 5, 1991.

⁵⁹ BOHSR estimated the Taiwan HSR construction would cost NT 441.919 billions (1USD=27NT) at the time. If so, including interest, its total expense would reach up to NT 674.8 billions. The media and congress even claimed this project would cost the central government more than NT 900 billion. In 1994, the central government's annual budget was 1,107 billion (See the Directorate General of Budget, Accounting and Statistics of Executive Yuan <http://win.dgbas.gov.tw/dgbas01/83btab/83b101.htm>). Except for the six-page introduction, the remaining twenty three pages of the *Taiwan HSR Construction Plan* were all devoted to the Taiwan HSR's financial plan and how to draw private investment for it. See POHSR, *Taiwan HSR Construction Plan* (Taipei: POHSR, 1993) and *West Taiwan Corridor HSR Construction Plan* (Taipei: POHSR, 1994). See more related discussions in chapter 5.

1994. The MOTC later in October 1996 announced it would solicit private bidders for the BOT HSR project. According to the main BOT principles, the private company who won the HSR contract would be responsible for paying for building the Taiwan HSR. The government's main jobs, among others,⁶⁰ were to acquire the lands needed for the Taiwan HSR and to monitor the elected BOT company, but not to offer any budget or other resources to build the HSR equipment, systems and construction. The BOT company would be allowed to operate the HSR for a certain period of time in order to get its investment back and earn itself a profit. But in the end it would transfer the HSR to the government after that concession period.⁶¹

3.3.1 Engineering Planning of Hybridity: National Differences Count

While the POHSR was pursuing private sector investment in its Taiwan HSR project, it was also following the conclusions of the WT-HSR-GP to work on the Taiwan HSR's detailed engineering and construction designs. Although Tong had left the POHSR at the time, his Railway Reconstruction invited the POHSR together to visit, among others, the TGV and Spanish HSR—AVE (Alta Velocidad Espanola)⁶² in early 1992. This visit attempted to learn about AVE's engineering and construction experience. According to Tong *et al*, the Spanish AVE was also a hybrid HSR product in terms of its integrated HSR subsystems. Its subsystems of rolling stock and electrical facilities⁶³ came from the TGV and ICE respectively.⁶⁴ Railway Reconstruction & POHSR visiting team learned from the Spanish engineers that they had consistently confronted interfacial engineering problems with these two subsystems when the

⁶⁰ See Fu-Hsiang Wu, "THSR New Records," in *Proceedings of the Fifth Cross-straight Tunnel and Underground Engineering and Technology Conference* (Taipei: Chinese Taipei Tunneling Association, 2006). See Ching-Lung Liao, "The Application of BOT Approach to Large Scale Infrastructure Projects—A Case Study of Taiwan High Speed Rail Project," *High Speed Rail News letter* 1: 22 (1997): 1~7.

⁶¹ BOHSR, *Memorial Collection for the THSR Open to Traffic* (Taipei: BOHSR, 2007), 2~8.

⁶² The AVE began construction in 1986 and has opened to traffic in April 1992.

⁶³ Railway Reconstruction's report did not clarify what the electric facilities were referred to. The POHSR's *HSR Electrical Affairs Intern Report* indicated that the HSR electrical affairs consisted of the power supply, signaling and communication subsystems. (See POHSR, *HSR Electrical Affairs Intern Report* (Taipei: POHSR, 1991)).

⁶⁴ Railway Reconstruction Bureau, *Visiting Report on HSR, Channel Tunnel and Mountain Tunnels* (Taipei: Railway Reconstruction Bureau, 1992), 14.

AVE was under construction. They revealed that this was mainly because the Spanish HSR engineers did not set up general engineering specifications in advance in order to integrate the French and German core subsystems. In addition, the French and German HSR systems had been integrated nowhere else before. Although those interfacing problems were all solved in the end, the Spanish AVE engineers shared with the visiting team their unpleasant experience of spending a considerable period of time and a lot of man power to achieve this integration. The visiting team thus came to the conclusion in their report that the Taiwan HSR should adopt an integrated rolling stock, catenary and signaling subsystems.⁶⁵

It seems that this visit to Spain was intended to endorse POHSR's earlier suggestion of adopting an integrated core subsystem in the WT-HSR-GP report. However, it did not go further to discuss Spain's solid history of railway industry development.

Although the [Spanish] Talgo train adopts French and German high-speed technologies, it represents Spain's past contribution to high-speed rail technology. Started in 1949, the Talgo company began manufacturing high-speed locomotives during the 1970s and 1980s in order to meet Spain's growing transportation corridors. Talgo developed a unique automatic gauge-switching system, whereby the approaching train transfers its weight to unlock the wheels connected to the track, and adjusting to a new track line. This system of track maintenance can be seen in virtually every high-speed rail transit project around the world.⁶⁶

⁶⁵ See Railway Reconstruction Bureau, *Visiting Report on HSR, Channel Tunnel and Mountain Tunnels*.

⁶⁶ Kamaal R. Zaidi, "High Speed Rail Transit: Developing the Case for Alternative Transportation Schemes in the Context of Innovative and Sustainable Global Transportation Law and Policy," *Temple Journal of Science, Technology & Environmental Law* 301 (2007): 319.

Unlike the AVE technology, which came mainly from the French TGV,⁶⁷ the POHSR's intentions to build its Taiwan HSR technology had been *really* open to Japan, France, Germany or even their hybrids. The POHSR understood that Taiwan had developed no high speed rail technology before. Moreover, as noted, the Taiwan railway industry has walked in a shaped trajectory in a manner that Taiwan Railways has been known of being dedicated to developing its expertise in maintaining and hybridizing existing and imported technologies. On the other side, the Spanish railway engineers' hybrid considerations were based on their technological backgrounds,⁶⁸ so they introduced the French HSR rolling stock and the German power supply system to their AVE. This Spanish hybridization was different from Tong's early idea of hybridizing the different HSR core subsystems. Spain's railway development brought its AVE some preferences to incorporate the TGV and ICE technologies. However, the Taiwanese railway engineers had been in a long process of hybrid engineering socialization. Like Tong, they were trained in a certain way to respond to foreign technologies. As Downey and Lucena point out "National differences count"⁶⁹ after they reviewed several historians and sociologists' work on the relationship among engineers, their knowledge and social contexts.

3.3.2 Engineering Thinking of Hybridity Flowed into the BOT Model

During the years from 1994 until it signed the BOT contract with the THSRC in 1998, the POHSR/BOHSR⁷⁰ was dedicated to generating appropriate and attractive opportunities in order to attract private investment. As noted, after the Executive Yuan announced it would privatize

⁶⁷ See Gunther Ellwanger and Martin Wilckens, "High Speed for Europe," *Japan Railway & Transport Review* 40 (1994): 17~25. Ryo Takaji, "High-speed Railways: the Last Ten Years," *Japan Railway & Transport Review* 40 (2005): 4~9. Javier Campos and Ginés de Rus, "Some Stylized Facts about High-speed Rail: A Review of HSR Experiences around the World," *Transport Policy* 16: 1 (2009): 19~28. Thomas Lynch, *High Speed Rail in the U.S.: Super Trains for the Millennium* (Amsterdam, Netherlands: OPA 1998).

⁶⁷ See Railway Reconstruction, *Visiting Report on HSR, Channel Tunnel and Mountain Tunnels*.

⁶⁸ *Ibid.* Also see Shun-Ping Kong (龔循平), *Visiting Report to Spanish and German Railway Industries* (Taipei: POHSR, 1995).

⁶⁹ Downey and Lucena, 399.

⁷⁰ The Bureau of High Speed Rail (BOHSR) was officially established in January 1997, while the POHSR (Provisional Engineering Office of High Speed Rail) was dissolved on the same day. As noted, the POHSR was established in July 1990.

the Taiwan HSR at the end of 1994, the POHSR commenced a series of preparatory tasks for the BT/BOT program.⁷¹ They included the Taiwan HSR's financial, legal and general engineering consulting. In addition, the POHSR was "seeking to contract academic institutions to conduct (close to 30) specific research projects to help distinguish the investment scope and responsibilities of the private sector under the BOT structure."⁷² After some planning and political struggles (I discuss this in chapter five), those financial, legal and general engineering preparatory tasks were integrated as one outsourcing project called general engineering services at the end of 1996.⁷³ Only domestic engineering consulting companies were allowed to bid on this project.⁷⁴ CECI was selected in March 1997 to provide general services until the Taiwan HSR project's completion. Before the POHSR/BOHSR contracted with its BOT partner, CECI's major tasks included:

1. evaluating the risks and insurance requirements for the HSR BOT project, 2. preparing methods and criteria to review proposals for the BOT Project, 3. assisting in the evaluation of these proposals, 4. assisting in conducting discussions and negotiations with the future BOT project company and in signing contracts concerning HSR construction and operation, and 5. judging and deciding the best locations to build three more stations along the HSR route as well as reviewing the budget of the overall HSR Project.⁷⁵

While it was looking for general engineering services, the BOHSR was also inviting private investment at the same time to take over its HSR BOT project. The BOHSR set up two evaluation stages to choose its future BOT partner. It solicited private tenders to join the first

⁷¹ POHSR, "Preparation of BOT Tender for HSR Project," *High Speed Rail Newsletter* 1: 2 (1995): 1.

⁷² *Ibid.*, 1.

⁷³ BOHSR, "Progress on General Consultant Services to HSR Project," *High Speed Rail Newsletter* 1: 14 (1997): 7.

⁷⁴ See *Economic Daily News*, "Tsai (蔡兆陽, Minister of MOTC): Re-soliciting General Engineering Consultant in Domestic," Aug. 12, 1996.

⁷⁵ BOHSR, "Progress on General Consultant Services to HSR Project," 7.

stage of qualification examinations from December 1996 to January 1997. Two private organizations—China Development Corporation (China Development; 中華開發公司) and Taiwan High Speed Rail Consortium (THSRC; 台灣高鐵聯盟)—submitted proposals to respectively introduce Japan’s Shinkansen and France’s TGV systems into Taiwan. Both tenders passed the first stage of quality review in February. The BOHSR then discussed subjects like investment conditions, privileges and responsibilities with China Development and THSRC. It also sent design criteria of civil works, tracks and stations and specifications of the core HSR system for their reference. Both China Development and THSRC went into the second evaluation stage. They sent complete plans to the BOHSR in July 1997. After the BOHSR and MOTC’s selection committee reviewed their plans, MOTC finally announced in September that THSRC was the Best Applicant for the HSR BOT project and China Development was the Second Best.⁷⁶ These invitation and review processes were actually far more complicated than I described above. I discuss them in greater detail in chapter five.

The BOHSR thus has gradually transformed from an engineering planner to a project manager since it turned the Taiwan HSR project into the format of BOT. The BOHSR not only handed over its engineering planning and other relevant business to the general service consultant CECI, but also intended to step back from their role of engineering specification-making in order to create more room for its private tenders. As a senior BOHSR engineer, Kai-Hsi Lee (李開熙), responded in an interview that the BOHSR had begun to play a role more like that of an engineering coordinator than a planner since the Executive Yuan decided to build the Taiwan HSR under the format of a privatization program. It had also attempted to bridge the government and private investments for the BOT HSR project. Especially after the THSRC won the BOT contract, the BOHSR kept working with other governmental agencies in order to help

⁷⁶ See BOHSR, “Selection and Evaluation of HSR Private Investment Application,” *High Speed Rail Newsletter* 1: 20 (1997): 4~5.

the THSRC deal with the related issues of power supply, import tariffs, land acquisition and local development etc. In addition, the BOHSR made some effort to promote traffic cooperation between the THSRC and Taiwan Railways. Although CECI assisted with overseeing and monitoring the THSRC, the BOHSR primarily aimed to give the THSRC as much engineering flexibility as possible.⁷⁷

Therefore, while it devoted itself to producing the Taiwan HSR within/under the format of the BOT and depended on CECI's general engineering services, the BOHSR drifted away from its earlier engineering ambition of building a hybrid HSR system on the west Taiwan corridor. The Chinese title of the BOHSR, Bureau of HSR "Engineering," might have inappropriately represented its core business; especially since the word engineering also refers to construction in Chinese. Kai-Hsi Lee and Fu-Hsiang Wu, a former BOHSR Director General, also agreed that the BOHSR has gradually become like Taiwan Railways in that their management work occupies a greater proportion of their main business than their engineering work.⁷⁸ The BOHSR then has been conducting the Taiwan HSR engineering planning and construction in an assisting way. The first BOHSR Director General Ching-Lung Liao argues that the BOHSR has been using their manpower very efficiently. The BOHSR hired only half the number of employees when it was established according to its organization regulations.⁷⁹ However, this efficiency might have also revealed that the BOHSR's business has shrunk in comparison with the Executive Yuan's expectations.⁸⁰

⁷⁷ An interview with Kai-Hsi Lee, director of the section of rolling stock, Third Division (Electrical & Mechanical), BOHSR.

⁷⁸ *Ibid* and an interview with Fu-Hsiang Wu.

⁷⁹ An interview with Ching-Lung Liao.

⁸⁰ According to BOHSR's email reply on October 28, 2009 (dock number: 98041), BOHSR was officially allowed to hire 270 employees in 1997. However, it hired only 186 in 1997 and 210 from 1998 to 2002. Actually, it is common for most of the governmental agencies in Taiwan that their real allowed numbers of hiring employees are lower than those numbers in their organization regulations. This was mainly because the KMT still kept the original governmental structure of the Republic of China after it fled to Taiwan in 1949. Nevertheless, Taiwan is much smaller than China in terms of population and geographic size. The KMT regime thus set up another system of number control (called budget number) for the governmental agencies on Taiwan. However, the BOHSR is not the case. It is an agency established in 1997. The above situation thus does not apply to the BOHSR. The number of

Although the BOHSR's stage role as a leading actor has been replaced by THSRC after they signed the BOT contract in 1998, this by no means meant that the BOHSR's early hybrid engineering experience and policy faded away. Rather, after the THSR project officially broke ground in 2000, its working practices have revealed the engineering hybridization more specifically. In other words, the Taiwan HSR project was not only intended to be planned as a hybrid, but also to be practiced in a hybrid way. Instead of an engineering phenomenon that only refers to governmental construction projects, engineering hybridization has been a product of engineering socialization both in the public and private sectors in Taiwan. I discuss these THSR engineering practices and how they connect to engineering hybridization and engineering socialization in chapters five and six.

the real hired BOHSR employees had been significantly less than its official number. Therefore, the BOHSR's business has been considerably less than the Executive Yuan's plan.

CHAPTER 4

DEMOCRATIZED AND INDIGENIZED STATE TRANSFORMATION SHAPED THE TAIWAN HSR PROJECT

While the last chapter discusses the emergence of the engineering culture that valued hybridity in the Taiwan HSR project, this chapter investigates what the political background behind the project was in the same two stages from 1973 to 1996. I attempt to answer the questions of why the Taiwan HSR project was chosen and how its policy was articulated by both the central government and political leaders. Instead of being a result of rational and economic planning, both Taiwan's democratized and indigenized state transformation shaped and reshaped the Taiwan HSR policy during this period. In addition to its transport and developmental visions, different policy actors encouraged the Taiwan HSR project to carry out the struggles of the identity politics between the Chinese and Taiwanese discourses since the late 1980s.

4.1 Authoritative State, Emerging Taiwanese Identity and the HSR Policy in the 1980s and Early 1990s

4.1.1 Fading Strongman Politics, National/His Development Projects, and the Taiwan HSR Abandoned in the 1980s

In her dissertation, Wen gave five reasons to explain why Taiwan Railways' Super Rail research gained little attention from the Executive Yuan in the late 1970s and 1980s. First, the Executive Yuan noticed that HSR technology had been improving over time since the Tōkaidō Shinkansen opened to traffic in 1964. It responded to the Legislative Yuan that "technically, for example, we have seen some new promising developments that maglev technology could be applied to the HSR core system in a near future...we should wait and conduct the general planning for the Taiwan HSR project after the current HSR technology shows no technical problems and its core system equips the most cutting-edge and reliable technology, such as the

maglev technology.”¹ Second, Taiwan Railways at the time was under the control of the Provincial Government, which made it difficult to substantially influence the central government of the Executive Yuan to support the Super Rail. Third, Taiwan Railways’ North Link and South Link projects had consumed a certain amount of the central government’s budget. The Executive Yuan was unlikely to make the Super Rail one of its high priority projects.

Fourth, citing from Jenn-Hwan Wang (王振寰), during the 1980s the KMT regime was confronting an unprecedented crisis relating to the political struggle over power succession. This was because the KMT leader as well as the president of the Republic of China, Chiang Ching-Kuo (蔣經國), had been very sick and might pass away at any time. Those KMT factions were fighting over political resources for the expected post-Chiang era. The Executive Yuan thus was generally incapable of increasing public investment and even of encouraging private investment.² Therefore, the Super Rail was very unlikely to become one of the KMT regime’s practical policies. Finally, the first national highway, National Sun Yat-Sen Highway,³ was completed in 1978, which significantly improved Taiwan’s transportation between the south and north along the west corridor.⁴

Although she identified the above five factors that caused Taiwan Railways’ Super Rail to be ignored and later to be abandoned by the Executive Yuan, Wen devoted no further effort to analyze them and explore the broader context behind them. I argue that they were conceptually located at different levels and they caused different effects on the Executive Yuan’s inactive or passive decisions. Moreover, some of them might be more like excuses or outcomes rather than

¹ See Legislative Yuan Gazette 76: 50 (1987): 90. http://lci.ly.gov.tw/lcew/index_5.zul

² See Jenn-Hwan Wang, *Who Governs Taiwan? State Machine and Power Structure in Transformation* (誰統治台灣? 轉型中的國家機器與權力結構) (Taipei: Liwen Publisher, 1996), chapter 2.

³ It also has been called National Highway No. 1, the first freeway in Taiwan. It begins in Keelung City and ends in Kaohsiung City, giving it a total length of 372.8 km. The Republic of China government named the freeway the Chung-shan Expressway (中山高速公路) in honor of Sun Yat-Sen (孫逸仙), who is the national father of the Republic of China.

⁴ Wen, 2-19~21.

factors. First, as noted in chapter three, the first Shinkansen line and the TGV opened to traffic in 1964 and 1981 respectively. They had accumulated plenty of engineering experiences and even made some significant progress before the mid 1980s. The Executive Yuan's response to the Legislative Yuan that it would not include the Super Rail in its list of transportation policy priorities until HSR technology advanced further thus was not convincing. As for factor two and three, they might seem like excuses instead of actual causes. If it was responsible for the North Link and South Link projects, Taiwan Railways should have been able to impact the Executive Yuan's transportation policy. In addition, the Executive Yuan still spent a certain percentage of its budget on other public projects after the 1970s' Ten Major Construction in the late 1970s and 1980s.⁵ As a result, factors two and three were more likely to be the outcomes of factor four. In other words, the KMT regime had no intention to spend its funds on building the Super Rail. The Super Rail reports, as noted in chapter two, sat quietly in the Executive Yuan since 1981 until it was abandoned when the Institute of Transportation was assigned to conduct research on the Taiwan HSR project in 1987. Finally, the fifth factor that the completion of the National Sun Yat-Sen Highway did effectively satisfy the north-south transport demands from the late 1970s until the mid 1980s, so the Super Rail might not be necessary to be carried out at that time. As a result, factors four and five might be the essential reasons that the Executive Yuan was unwilling to continue with the Super Rail.

Chiang's fading was a political crisis that further raised a broader political-economic phenomenon in Taiwan. Some of the annual growth rates of both public and private investments in the early 1980s were relatively much lower than those in the late 1970s and some of them

⁵ Yu-shan Liu (劉玉山), "Review on Infrastructure Projects with BOT Model (以 BOT 方式推動基礎建設之現況與未來)," in *Proceeding of the 1997 International Conference of Infrastructural Construction and BOT Planning (基礎建設與 BOT 計劃國際研討會)* (Taipei: 1997), 7-8. Chi-Chieh Fong (馮智捷), "Public Investment Impacts on Private Economy in Taiwan (台灣公共投資對私部門經濟影響之研究)," (Master thesis, National Taipei University, 2001).

were even negative.⁶ See Table 4.1. According to Wen and Wang, this slack investment phenomenon was not mainly caused by economic factors but by political influence. However, they might have overlooked the political-economic scheme behind the political influence they discussed. Wen and Wang argued that the KMT's internal struggle over political leadership was the main factor that caused the slack in investment in the early 1980s, but I argue that it should be an outcome instead of a factor. In other words, it was not the political struggle that prevented the public and private investment from constant growth as in past years. Rather, it was the political essence of the KMT's authoritarian regime that originally had no strength or intention to maintain high growth rates of public investment after the completion of the Ten Major Construction in the late 1970s.

Table 4. 1 Taiwan Domestic Investment Gross (public domain)

Domestic Investment Gross (unit: million NT dollar)							
Year	Sum	Private Sector		Public Enterprise		Government	
		Growth Rate	Investment Amount	Growth Rate	Investment Amount	Growth Rate	Investment Amount
1960	12,692	29.54%	6,908	51.33%	4,346	9.97%	1,438
1961	14,053	10.72%	8,139	17.82%	4,319	-0.62%	1,595
1962	13,799	-1.81%	7,308	-10.21%	4,818	11.55%	1,673
1963	16,029	16.16%	10,214	39.76%	4,034	-16.27%	1,781
1964	19,178	19.65%	12,528	22.66%	4,435	9.94%	2,215
1965	25,652	33.76%	17,553	40.11%	5,689	28.28%	2,410
1966	26,847	4.66%	17,482	-0.40%	6,609	16.17%	2,756
1967	35,983	34.03%	22,427	28.29%	10,213	54.53%	3,343
1968	42,764	18.85%	27,024	20.50%	11,638	13.95%	4,102
1969	48,446	13.29%	28,056	3.82%	15,102	29.76%	5,288
1970	58,147	20.02%	34,709	23.71%	16,847	11.55%	6,591
1971	69,434	19.41%	41,217	18.75%	20,938	24.28%	7,279
1972	81,525	17.41%	49,000	18.88%	24,155	15.36%	8,370
1973	119,951	47.13%	75,901	54.90%	32,241	33.48%	11,809
1974	216,142	80.19%	133,746	76.21%	64,591	100.34%	17,805
1975	180,166	-16.64%	75,912	-43.24%	78,835	22.05%	25,419
1976	217,671	20.82%	98,973	30.38%	83,744	6.23%	34,954
1977	234,791	7.87%	115,261	16.46%	75,975	-9.28%	43,555

⁶ See National Statistics, Republic of China (Taiwan), "Gross National Savings and Gross Domestic Investment" <http://www.stat.gov.tw/ct.asp?xItem=15060&ctNode=3565>

Domestic Investment Gross (unit: million NT dollar)							
Year	Sum	Private Sector		Public Enterprise		Government	
		Growth Rate	Investment Amount	Growth Rate	Investment Amount	Growth Rate	Investment Amount
1978	281,356	19.83%	151,702	31.62%	86,377	13.69%	43,277
1979	395,167	40.45%	233,838	54.14%	109,335	26.58%	51,994
1980	505,941	28.03%	257,844	10.27%	179,445	64.12%	68,652
1981	532,633	5.28%	263,931	2.36%	189,402	5.55%	79,300
1982	490,261	-7.96%	236,414	-10.43%	169,927	-10.28%	83,920
1983	530,731	8.25%	296,651	25.48%	155,151	-8.70%	78,929
1984	562,150	5.92%	348,862	17.60%	129,242	-16.70%	84,046
1985	489,140	-12.99%	284,357	-18.49%	114,487	-11.42%	90,296
1986	572,782	17.10%	370,865	30.42%	102,569	-10.41%	99,348
1987	729,921	27.43%	474,705	28.00%	141,802	38.25%	113,414
1988	896,435	22.81%	609,618	28.42%	141,422	-0.27%	145,395
1989	979,185	9.23%	610,606	0.16%	182,625	29.13%	185,954
1990	1,079,424	10.24%	584,309	-4.31%	254,670	39.45%	240,445
1991	1,224,332	13.42%	665,174	13.84%	260,214	2.18%	298,944
1992	1,484,942	21.29%	860,042	29.30%	271,603	4.38%	353,297
1993	1,666,512	12.23%	990,181	15.13%	246,384	-9.29%	429,947
1994	1,775,141	6.52%	1,061,392	7.19%	237,170	-3.74%	476,579
1995	1,942,245	9.41%	1,201,438	13.19%	240,619	1.45%	500,188
1996	1,894,666	-2.45%	1,181,967	-1.62%	221,024	-8.14%	491,675
1997	2,150,484	13.50%	1,445,319	22.28%	212,511	-3.85%	492,654
1998	2,392,515	11.25%	1,692,086	17.07%	200,831	-5.50%	499,598
1999	2,409,154	0.70%	1,626,010	-3.91%	267,228	33.06%	515,916
2000	2,615,640	8.57%	1,885,115	15.94%	241,986	-9.45%	488,539

Source: National Statistics, Republic of China (Taiwan), “Gross National Savings and Gross Domestic Investment”

Although he mainly cited Chin-Ching Liu’s (劉進慶) study, Wang might misunderstand a subtle but important point in Liu’s arguments regarding the role of the KMT regime at the time. Wang claimed,

The KMT government was unable to encourage private investment through its public investment due to its crisis of political succession and its incapacity on economic policy at the time... Those political and economic crises, with some other specific financial and political cases, made the KMT regime impotent in some years before 1985. It hardly well

*confronted those challenges from the capitalists, political and social movements at the time...*⁷

However, Liu attributed the phenomenon of slack public investment in early 1980s Taiwan to structural problems in the KMT regime itself rather than its political crisis over power succession. He argued that the KMT regime, including the government and its public monopoly enterprises, which included most of the infrastructural industries and financial sector, hindered private investment in Taiwan in the early 1980s. This was because they had effectively collected and controlled Taiwan's private capital accumulation.⁸ Some of those public monopoly enterprises were not only reluctant to invest but even constantly produced huge deficits before the 1980s.⁹ The KMT regime controlled more than half of the gross fixed capital and most of the low capital in Taiwan, but it did not manage it well. Even though he also indicated that the political crisis in the KMT regime might hurt the growth of private investment, Chin-Ching Liu did not argue that the slack public investment was due to the crisis.¹⁰ As a result, the KMT regime might still have avoided public investment even if there were no political crisis of power succession at the time.

I have no intention to discuss the whole phenomenon of slack public and private investment in Taiwan during the early 1980s,¹¹ but here I want to indicate that the KMT leadership crisis at the time was not the essential factor that caused low public investment and further the Executive Yuan's ignorance and abandonment of the Super Rail. Some studies have

⁷ Jenn-Hwan Wang, 71.

⁸ See Chin-Ching Liu, *Diagnosing Taiwan: Economy in the Transformative Period* (中日會診台灣: 轉型期的經濟), ed. Masahiro Wakabayashi (若林正文) and trans. Yan-Hung Chen (陳艷紅) (Taipei: Koo-Hsiang Publication, 1988), especially chapter 5.

⁹ See Chin-Ching Liu, *Analyses on Taiwan's Economy after WWII* (台灣戰後經濟分析) (Taipei: Ren-Jen Publication, 1995), especially chapter 2. Also see Chan-Pu Dwan (段承璞) ed., *Taiwan's Economy after WWII* (台灣戰後經濟) (Taipei: Ren-Jen Publication, 1994), especially chapter 5.

¹⁰ See Chin-Ching Liu, *Diagnosing Taiwan: Economy in the Transformative Period*.

¹¹ See more Chin-Ching Liu, *Diagnosing Taiwan: Economy in the Transformative Period*. Dwan ed. Kai Ma (馬凱), "Evolution of Taiwan Industrial Development Policy," in *Proceedings on Taiwan Industrial Development*, ed. Kai Ma (Taipei: Linking Publishing Co., 1976), 129~89.

shown that the Ten Major Construction in the 1970s (mainly from 1973 to 1979) was an unprecedented infrastructural construction conducted by the KMT regime in terms of budget scale since it fled from China and rebuilt itself in Taiwan after the Second World War. Among the ten major construction projects, seven of them were infrastructural construction, including Taiwan Railways' Electrification Project, National Sun Yat-Sen Highway, Chiang Kai-shek International Airport, Suao and Taichung International Seaports and the First Nuclear Power Plant.¹²

There were some other infrastructure projects before the 1970s. However, some of them were dedicated to repairing and recovering those infrastructures damaged during the Second World War.¹³ In addition, most of the new projects were mainly supported by U.S. aid before 1965.¹⁴ Table 4.2 shows that the U.S. capital assistance supported more than 30 percent of Taiwan's domestic investment. The percent of the U.S. capital assistance to Taiwan's domestic investment on infrastructure even reached 74 percent. Those public investment projects during the years between 1951 and 1965 were primarily focused on basic investment, such as power and water supply.¹⁵ The KMT regime was only capable of making a modest effort toward infrastructural construction in Taiwan at the time. The amount of the public investment in infrastructure from 1965 to 1973 was considered much less than the Ten Major Construction's,¹⁶ even though the KMT regime had begun to accumulate some capital with its industrial production from Taiwan's economic growth.¹⁷

¹² The other three projects were the China Steel Factory, China Shipbuilding Corporation Shipyard and Oil Refinery and Industrial Parks.

¹³ See Jacoby. Chi-Chang Chiao (趙既昌), *US Aid to Taiwan (美援的運用)* (Taipei: Linking Publishing Co., 1985). Tsong-Min Wu (吳聰敏), "U.S. Aid and Taiwan's Economic Development," *Taiwan: A Radical Quarterly in Social Studies* 1:1 (1988): 145~58.

¹⁴ *Ibid.*

¹⁵ *Ibid.*

¹⁶ See Fong.

¹⁷ Dwan ed., 109.

Table 4. 2 U.S. Capital Assistance Obligations and Net Domestic Investment by Major Sections, 1951~63 (In U.S. Dollar Equivalents) (used under fair use guidelines)

Sector	Net Domestic Investment		U.S. Capital Assistance		Per cent of U.S. Capital Assistance to Domestic Investment
	Amount (millions)	Per cent	Amount (millions)	Per cent	
Infrastructure	\$ 481	18.5	\$ 356	44.0	74.0
Agriculture	329	12.6	193	23.8	58.7
Human Resources	577	22.1	104	12.8	18.0
Industry	1,218	46.8	157	19.4	12.9
TOTALS	\$2,605	100.0	\$ 810	100.0	31.1
Public	\$1,253	48.0	\$ 649	80.1	51.7
Private	1,353	52.0	161	19.9	41.8
TOTALS	\$2,605	100.0	\$ 810	100.0	31.1

Source: Neil Jacoby, *U.S. Aid to Taiwan: a Study of Foreign Aid, Self-help, and Development* (New York: Praeger, 1966), 52.

Although it was greatly appreciated after its completion in the late 1970s, the Ten Major Construction earned no general consensus at the time Chiang proposed it to the KMT regime. The Ten Major Construction encountered questions, challenges and even resistance not only from the congress, but also from the administration and from inside the KMT.¹⁸ It was believed that Chiang's determination was the key factor that made the Ten Major Construction possible and successful.¹⁹ Chiang's decline, therefore, as Wang argued, might have led to the low public

¹⁸ See L. Sophia Kang (康綠島), *K. T. Li Oral History: Talking Taiwan Experience* (Taipei: Excellence Publications & Printing Inc.), 216.

¹⁹ See Jay Taylor, *The Generalissimo's Son: Chiang Ching-Kuo and the Revolution in China and Taiwan* (Cambridge, MA: Harvard University Press, 2000), chapter 18.

investment in the early 1980s after the Ten Major Construction. However, Chiang's determination and decline might reveal a further and deeper structural issue that might have been undermined. In other words, it should be more likely that the authoritarian KMT regime and its bureaucratic-capital system were playing a solidly inactive role of discouraging the infrastructural construction in Taiwan at the time.

While Chiang wielded his determination on the Ten Major Construction, this also demonstrated that, as Mikio Sumiya *et al* argued, "Taiwan's public finance had been placed in the mechanism of 'dictatorial economic development' for a long time. Under this mechanism, there was almost no policy debate and openness to the public."²⁰ Therefore, the different KMT factions were struggling over the political leadership left by Chiang's decline *within* the KMT regime. They understood that their political interests, which were similar to Chiang's power of determination, would come from the authoritarian regime instead of the people on the island of Taiwan.

Rather than being impotent as Wang argued, it would be more accurate to say that it was the KMT regime's inertia that contributed to the low growth of public investment in Taiwan in the early 1980s. The KMT regime had not been well equipped with substantial economic strength in the 1950s and 1960s. Then, it showed less interest and intention to do infrastructural and even public investment in the 1970s, even though it had started acquiring more and more capital through profits earned from Taiwan's exportation. The KMT regime had remained focused on national defense and production investment in order to prevent an invasion of Taiwan by the People's Republic of China and maintain its authoritarian power over the people on the island of Taiwan.²¹ Chiang's determination should be understood as an exception and the crisis

²⁰ Mikio Sumiya (隅谷三喜郎) *et al*, *Taiwan's Economy: Typical NIES Achievements and Problems* (台灣之經濟—典型 NIES 之成就與問題), trans. Hui-Ying Ray (雷慧英) *et al*, (Taipei: Ren-Jen Publication, 1993), 268.

²¹ The total expenditure for national defense was around 30% of the central government's annual budget in the 1970s and a quarter in the 1980s. It even reached 40% in the 1960s, but dropped to almost 16% in the 1990s and nearly 11% in the 2000s. .

resulting from his decline was like an outcome of the KMT authoritarian regime instead of a real cause for the low growth of public investment in the early 1980s.

After the Ten Major Construction's completion in 1978, the KMT regime promoted the Twelve New Development Projects (12 New Projects; 十二大建設) and Fourteen Major Infrastructure Plans (14 Major Plans; 十四大建設) from 1978 and 1984 respectively.²² Although they did not create higher growth rates of public investment, the 12 New Projects, 14 Major Plans and some other public projects in the 1980s contributed to the KMT regime being able to maintain a similar level of public investment as the Ten Major Construction in the late 1970s.²³ See Table 4.1. Despite no further extension, the KMT regime generally maintained Chiang's will. The 12 New Projects was considered another Ten Major Construction in that Chiang determined to conduct it without a specific policy and finance source in advance.²⁴ However, the Ten Major Construction, 12 New Projects and 14 Major Plans had some differences in terms of policy goals. While the Ten Major Construction focused more on infrastructure and production projects, the 12 New Projects and 14 Major Plans included more social projects.²⁵ See Table 4.3. Basically the 12 New Projects was an intermediate plan between the Ten Major Construction and 14 Major Plans in that it extended some of the Ten Major Construction's major projects and began to include some social projects. The 14 Major Plans not only inherited some projects from the Ten Major Construction and 12 New Projects,

²² Chiang announced the 12 New Projects in 1977, but, according to K. T. Li, "it had no specific study and schedule. The 12 New Projects was just the Ten Major Construction in a manner that the government did not know where their budget would be from until their announcement." As a result, the KMT began the 12 New Projects in 1978. See Kang, 216. Also see K. T. Li, *The Evolution of Policy behind Taiwan's Development Success* (New Haven, CT: Yale University Press, 1988), appendix: policy matrix for Taiwan economy, 156. *United Daily*, "Editorial: Chiang Announced 12 New Projects after Ten Major Construction Completed," Sep. 24, 1977.

²³ While the Ten Major Construction cost the KMT regime around 5 billion dollars US (1 USD=40 NTD, New Taiwan Dollar), the 12 New Projects 218 billion NTD and the 14 MIP NTD. See Kang, 214. Also see Jin-Po Lai (賴金波), "Benefit Analysis on the 12 New Projects," *Journal of Taipei Municipal Bank* 9: 12 (1978): 75~7.

²⁴ "The 12 New Projects was similar with the Ten Major Construction in a manner that there was no specific research, plan and financial sources but only listing vague and general items," said K. T. Li. L. Kang, 216. Also see footnote 22.

²⁵ Kang, 216.

but also highlighted projects emphasizing social welfare and local development. The Ten Major Construction, 12 New Projects and 14 Major Plans reflects a trend indicating that the KMT regime was more concerned about the people than production on the island of Taiwan.

Table 4. 3 Ten Major Construction, 12 New Projects and 14 Major Plans

(used under fair use guidelines)

	Infrastructures	Pubic Enterprises	Agricultural	Urban & Area Development	Social Construction
Ten Major Construction	1. National Sun Yat-sen Highway, 2. WTL Electrification Project 3. NLL Railway Project 4. Taoyuan International Airport 5. Taichung Port 6. Suao Port 7. Nuclear Power Plant	1. China Shipbuilding Corporation Shipyard 2. China Steel Factory (CSF) 3. Oil Refinery and Industrial Park			
12 New Projects	1. 2 nd and 3 rd Nuclear Power Plants 2. SLL & Taitung Line Railway Project 3. Cross Island Highway Projects 4. Pingtung-Cape Eluanbi Expressway Extension 5. Pingtung to Kaohsiung Traffic Project 6. Taichung Port Extension Project	1. CSF Extension Project	1. Agricultural Advancement Project 2. Farm and Irrigation Facility Project 3. Coast Protection Project	1. New Town Project	1. Public Housing and Culture Center Project
14 Major Plans	1. 4 th Nuclear Power Plant 2. Telecommunication Project 3. Railway Extension Project 4. Highway Extension Project 5. Water Resource Development Project	1. CSF Second Extension Project 2. Oil and Energy Exploration Project		1. Taipei Railway Underground Project 2. Taipei Rapid Transit Project 3. Flooding Prevention Project 4. Urban Disposal Project	1. Natural Conservation and Domestic Tour Project 2. Health Insurance Project 3. Local and Rural Construction Project

Source: Organizing from Won-Ahn Yeh (葉萬安) and Jin-Po Lai.

Chart 4. 1 Taiwan Economic Growth Rate, 1951~2010 (public domain)

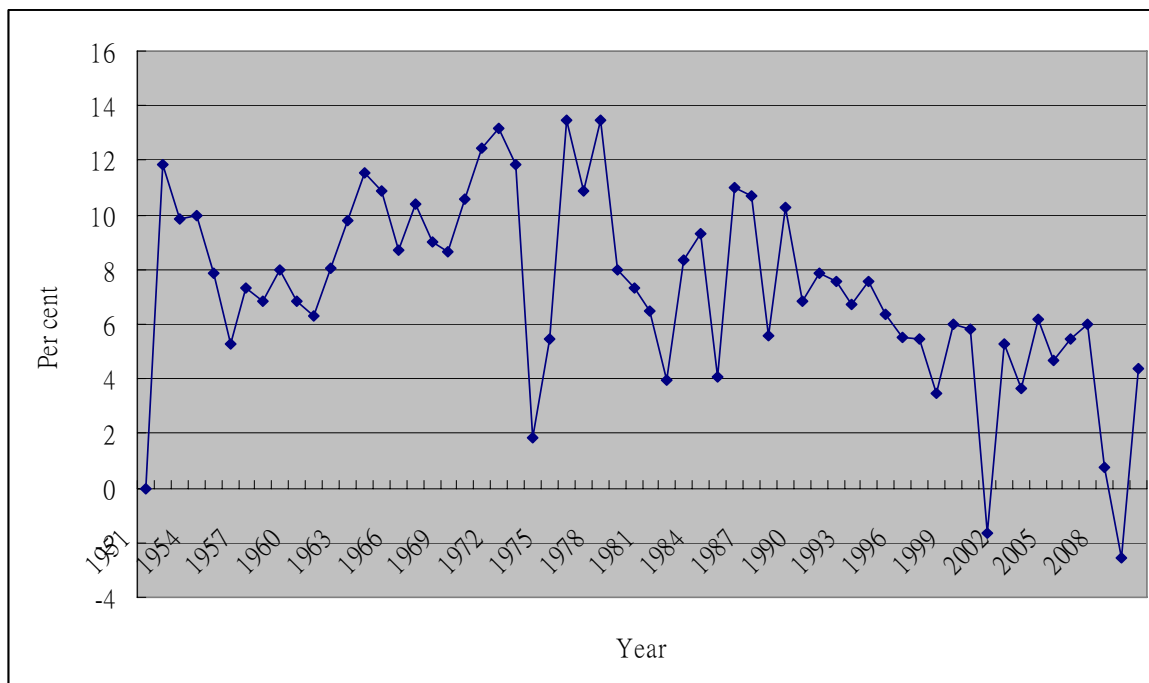

Source: National Statistics, Republic of China (Taiwan) <http://www.stat.gov.tw/mp.asp?mp=4>

Some studies have shown that the trend of public investment that increasingly focused on social construction in the 1980s was due to the consequences of constant and high economic growth in the 1960s and 1970s.²⁶ Chart 4.1 shows that Taiwan experienced eight percent growth in most years except during the years of the worldwide energy crisis. Some years even reached more than ten percent. Those studies argued that some Chinese/Taiwanese people’s quality of life could not catch up with their economic growth in the early 1980s. The KMT regime thus made some public investment in social projects in order to respond to this imbalance.²⁷ However, like the Ten Major Construction, both the 12 New Projects and 14 Major Plans had no policy

²⁶ See Fong and Lai. Also see Won-Ahn Yeh, “Taiwan’s Economic Plan,” in *The Taiwan Experience: 1949~1989*, ed. H. C. Kao and Joseph S. Lee (Taipei: Commonwealth Publishing, 1993), 46~75. Chung-Hsiung Lin (林鐘雄), *Taiwan’s 40-Year Development Experience* (Taipei: Tzu-Li Nightly Publication, 1987).

²⁷ *Ibid.*

debates with most of the Chinese/Taiwanese people on the island of Taiwan either.²⁸ Indeed, these developmental plans brought some positive effects in terms of quality of life improvement, but they were not based on the public participation. They were parts of the KMT regime's *good* economic and development plans.²⁹ Until the early 1990s, some politicians in the KMT regime still publicly stated that they believed the KMT should remain the leading political actor because it could make appropriate policies for most of the Chinese/Taiwanese people.³⁰

While the KMT regime was working on more social and infrastructural projects, an increasing number of dissident events erupted during the late 1970s through the 1980s in Taiwan. The KMT regime was in the process of transformation in which it was forced to respond to an increasing number of political, social and economic issues from the Chinese/Taiwanese people.³¹ This transformation encouraged the KMT regime to undertake more public investment and infrastructure projects. This transformation process was complicated, but my project does not attempt to explore this whole picture. My intention is to point out that those infrastructure projects before the 1990s had little participation from the Chinese/Taiwanese public. In addition, the KMT regime was inclined to include more and more social projects in conjunction with the progress of the local democratic movement in the 1980s. As a result, if there had been no determination by Chiang and his fellow technocrats who effectively implemented those developmental projects from the late 1970s to the 1980s, the KMT authoritarian regime would have kept its inertia of slack public investment.

4.1.2 Emerging Democratic Politics, Living Community, and the Taiwan HSR Needed in the Early 1990s

²⁸ Chin-Ching Liu, *Analyses on Taiwan's Economy after WWII*, 268.

²⁹ See Won-Ahn Yeh.

³⁰ Chin-Ching Liu, *Analyses on Taiwan's Economy after WWII*, 268.

³¹ Jenn-Hwan Wang, especially chapter 2.

The government announced the Six-Year National Development Plan (6-Year Plan) in January 1990, whose investment scale of budget amount should reach around 8,500 billion NTD (about 316 billion USD).³² It was the first such enormous mid-term development plan being proposed after Teng-hui Lee (李登輝) took over the president office. The 6-Year Plan was also the first development plan that raised the Taiwanese people's debates and lots of responses of their opinions in Taiwan history... Unless the 6-Year Plan could escape from the ghost of dictatorial economic development, Taiwan's public finance could make itself entitled with both the name and content of so-called national development.—Chin-Ching Liu³³

Chin-Ching Liu showed his expectation and worries of how Lee would conduct the 6-Year Plan in terms of the interaction between his administration and the Chinese/Taiwanese public. It might be fair to say that the 6-Year Plan's outfit was close to Chin-Ching Liu's expectation. The 6-Year Plan generated discussion and participation among the congress, local elites, and even inside the administration, but it also became a part of Lee's political discourses speaking to the Chinese/Taiwanese public. According to its plan, the 6-Year Plan's goal was to "rebuild economic and social orders, and seek a comprehensive and equilibrium development."³⁴ In other words, the 6-Year Plan was designed to adjust and even correct the KMT regime's past development plans that focused on production investment or other activities in order to promote economic growth. As a new developmental plan with a different discourse, the 6-Year Plan

³² The annual average exchange rate was 1 USD equaled to 26.89 NTD in the year of 1990. See Central Bank of the Republic of China (Taiwan) <http://www.cbc.gov.tw/content.asp?CuItem=1879> Another estimate number was 8,800 billion NTD. See Kuo-Shu Liang (梁國樹), *Kuo-Shu Liang's Economic Policy Recommendations 3: Taiwanese Economic Development Policy* (Taipei: Yuan-Liou Publishing, 1998), 29.

³³ Chin-Ching Liu, *Analyses on Taiwan's Economy after WWII*, 268.

³⁴ Council of Economic Planning and Development (Economic Council), *Six-Year National Development Plan (Draft) (1991~1996) Volume 1: Goals of Macro Economic Development* (Taipei: Economic Council, 1990), 2.

highlighted the improvement of the majority of the Chinese/Taiwanese people's standard of living, by which Lee hoped to earn their political support. Although it was not Lee's only strategy to solidify his presidency in the Republic of China government and his leadership in the KMT after Chiang's death,³⁵ the 6-Year Plan was one of his most important policies for collecting political resources from outside the KMT regime.

In its draft plan, the Council of Economic Planning and Development (Economic Council; 行政院經濟建設委員會)³⁶ of the Executive Yuan stated that the 6-Year Plan's fundamental idea of how to carry out Taiwan's macro economic development was to strengthen and increase public construction.³⁷ "While we are confronting double pressure from long-term economic adjustments and short-term international impacts over the past several years, we should strengthen and increase public construction in order to stimulate economic growth and make up the past years' insufficient public investment."³⁸ The 6-Year Plan was intended to accelerate the growth rate of public investment and even to elevate it higher than that of private investment in the early 1990s.³⁹ In addition, unlike the Ten Major Construction, 12 New Projects and 14 Major Plans that were founded during the KMT authoritarian regime, the 6-Year Plan represented a sort of nationalism in that the majority of the Chinese/Taiwanese people took priority over the government and they were handed the power to define what social progress and economic prosperity were for themselves.⁴⁰ Thus, the 6-Year Plan not only covered production,

³⁵ See Shih-Shan Henry Tsai, *Lee Teng-hui and Taiwan's Quest for Identity* (NY: Palgrave Macmillan, 2005), especially chapter 8 and 9.

³⁶ "The Council for Economic Planning and Development (Economic Council) evolved from the Council for U.S. Aid (CUSA), which was established as part of the Sino-American Economic Aid Agreement signed between the Republic of China and the United States in 1948. In September 1963, CUSA was re-formed as the Council for International Economic Cooperation and Development (CIECD), which in turn became the Economic Planning Council (EPC) in 1973 for the purpose of strengthening the Executive Yuan's planning and research functions. In 1977, the EPC merged with the Executive Yuan's Finance and Economic Committee and was reorganized as the Economic Council to promote comprehensive national economic development." See more at <http://www.cepd.gov.tw/encontent/m1.aspx?sNo=0001432&key=&ex=%20&ic=&cd=>

³⁷ See Council for Economic Planning and Development .

³⁸ *Ibid.*, 7.

³⁹ *Ibid.*, 8.

⁴⁰ Chyuan-jenq Shiao (蕭全政), "Political-economic Meanings of the Six-Year National Development Plan," in

industrial and infrastructural projects, but also several agricultural, rural, housing, environmental and social welfare plans. It seemed that the Lee government fully demonstrated its attempts to establish a dialogue and construct a vision with the Chinese/Taiwanese people. As one of the most important political discourse of “Living Community (生命共同體)” that Lee proposed in the 1990s,⁴¹ the 6-Year Plan was the first developmental program considered to link the government to its majority of people through public investment and construction in Taiwanese history.⁴²

Unfortunately, as noted, the 6-Year Plan might satisfy Chin-Ching Liu’s expectation in terms of format instead of substance. As Wang put it, “through the 6-Year Plan, on the one hand, the KMT regime attempted to stimulate economic growth by pouring significant public investment; on the other hand, it wanted to attract foreign and local capital and then work with them in order to strengthen their alliance relationship.”⁴³ The Lee government intended to gain political support from local elites and capitalists while showing its focus on the majority of the people’s economic and standard of living improvements. However, except for some projects including the Taiwan HSR project that remained after 1993, the 6-Year Plan had gradually faded away along with Lee’s victories in some significant political struggles in the early 1990s. As he stated in 1992, “currently the Republic of China should change its policy priority from economic development to constitutional revolution and cultural reestablishment.”⁴⁴ Although it was the most phenomenal development program, the 6-Year Plan was still subject to Lee’s program of

Taiwan’s New Thinking: Nationalism (Taipei: Shi-ying Publishing, 1995), 178~9.

⁴¹ Lee firstly proposed the political idea of living community in his third-year inauguration speech on May 20, 1993. See more Government Information Office ed., *President Teng-hui Lee 1993 Speech Selection* (Taipei: Government Information Office, 1994).

⁴² See Shiao, 178~9. Also see Kuo-Shu Liang, “Making Consensus of Living Community: Practicing and Commuting Taiwan’s Development Experiences,” in *Kuo-Shu Liang’s Economic Policy Recommendations 3: Taiwanese Economic Development Policy*, 137~51. Duan Wei (韋端), “Six-Year National Development Plan: Hard but Favored,” *Commonwealth Magazine* 117 (1991): 58~9.

⁴³ Jenn-Hwan Wang, “New Political and Business Relationship and Political Transformation in Taiwan,” *Taiwan: A Radical Quarterly in Social Studies* 14 (1993), 149.

⁴⁴ Teng-hui Lee, *Managing Great Taiwan (經營大台灣)* (Taipei: Yuan liou Publishing Co., 1995), 419~20.

peaceful political revolution in the early 1990s. Therefore, after Lee won some significant political victories over the powerful Chinese mainlanders in the KMT and stabilized his leadership in the KMT regime, the 6-Year Plan could no longer hide its serious problems of financial shortage and lack of detail planning etc.⁴⁵

Chan Lien (連戰), who was Lee's first Taiwanese premier of the Executive Yuan after three Chinese premiers,⁴⁶ announced another new Stimulus Program (振興經濟方案) in 1993, the same year he took over the position. Although he did not explicitly indicate that his Stimulus Program was intended to replace the 6-Year Plan, Lien asked the Executive Yuan to review the 6-Year Plan and cancel its several projects.⁴⁷ This was mainly because some of the 6-Year Plan's problems quickly popped up and drew the public's attention after some political struggles over the leadership between the Taiwanese and Chinese mainlanders in the KMT were finished.⁴⁸ Among other things, the 6-Year Plan's financial shortage was one of the most serious problems. It had seriously deteriorated the government budgeting structure at the time.⁴⁹ Lien thus highlighted that his Stimulus Program aimed to reduce governmental expense and introduce private investment in order to alleviate the central government's financial burden. Soon after he proposed the program in January 1994, Lien started to claim that those twelve major construction plans (12 Plans; 十二項計畫) in the 6-Year Plan were the most core projects to the Executive Yuan.⁵⁰ Compared with the 6-Year Plan, Lien's 12 Plans were significantly shrunk in terms of

⁴⁵ See *Economic Daily*, "6-Year Plan Away From Original Goals," Dec. 18, 1995. *Economic Daily*, "Editorial Review: Deterioration and Improvement on Government Budgeting," Jan. 9, 1994. *Economic Daily*, "Editorial Review: How to Reduce Serious Deficits for Government Budgeting," Sep. 18, 1993. *United Daily*, "Review 6-Year Plan Especially Transportation Project: Lack of Detail Plans," Mar. 8, 1993. *Economic Daily*, "Minister of Ministry of Finance: 6-Year Plan's Key Problem: Mistaken Finance Planning," Apr. 20, 1993.

⁴⁶ They were Kuo-Hwa Yu (俞國華), Hwan Lee (李煥) and Pei-tsun Hau.

⁴⁷ See *United Daily*, "12 Plans Cost 2,500 Billion NTD: Pick Core Projects in 6-Year Plan and Encourage Private Sector Participation to Alleviate Budget Pressure," Jan. 11, 1994.

⁴⁸ Along with some key KMT mainlanders lost political strength, Hau also stepped down the premier position in 1993. See more Shih-Shan Henry Tsai. Ching-Wen Chou (鄒景雯), *Teng-hui Lee's Governance Recording (李登輝告白實錄)* (Taipei: Ink Publication, 2001).

⁴⁹ See *Economic Daily*, Sep. 18, 1993. *Economic Daily*, "6-Year Plan Midterm Review: Allow More Detail and Open Discussion on Budgeting," July 3, 1993. *Economic Daily*, Apr. 20, 1993.

⁵⁰ See BOHSR, "High Speed Rail Meeting Future Transportation Demand," *High Speed Rail Newsletter* 1: 1 (1995):

the total amount of planning budget, from 8,500 to 2,900 billion NTD.⁵¹ It was clear that the name of the 6-Year Plan had gradually disappeared. As a result, even though the 6-Year Plan policy still existed in the Lien administration, it had been fading over time. The Lien administration had distanced it from the 6-Year Plan policy and started turning to focus on its Stimulus Program and 12 Plans since 1993.

Even though the 6-Year Plan faded away in the early 1990s, the Taiwan HSR as one of the 6-Year Plan's projects survived and even drew increasing attention over the years. In fact, the Taiwan HSR project also confronted similar financial and planning problems as other projects in the 6-Year Plan. These problems further caused serious conflicts among and within the administration, congress and the public. Some congressmen, scholars and opinion leaders even proposed to postpone or terminate the Taiwan HSR project.⁵² However, Lee and his Lien administration expected the Taiwan HSR to represent and realize his idea of community economy, since it was one of the critical projects in the 6-Year Plan that closely tied the national development with the majority of the people on the island of Taiwan.⁵³ The Executive Yuan and Legislative Yuan made huge efforts to keep it alive, even though the Taiwan HSR policy was significantly changed later. Basically, the Taiwan HSR project was needed and indispensable. Not only did 80% of the Taiwanese population want to build it,⁵⁴ but also the administration, congress and some local power needed it to solidify and establish their political power.

4.1.3 Actual State Politics on the Taiwan HSR Privatization Policy, 1991~1994

1~2. Also see Li-Yu Yang (楊力宇), *A New Taiwan and a New Era: Lien Chan's Contribution and Dedication* (Taipei: Liu Chung Publication, 2000), 112~4.

⁵¹ Council for Economic Planning and Development, "Implementation Review Report on the 12 Construction Plans," *Industry of Free China* 83: 4 (1995), 11~23.

⁵² See Legislative Yuan, *Highspeed Trains (Chinese Legislative News Review Series; V. 49)* (Taipei: Legislative Yuan Library & Information Service, 1994).

⁵³ See Shiao, 178~9.

⁵⁴ See *United Nightly*, "MOTC Commission Gallup Poll Mostly Pro HSR Project," July 3, 1993. *Economic Daily*, "Gallup Poll Shows Over 80% Population Support HSR Project," July 4, 1993.

Although it had intended to introduce some private investment and even planned to privatize the Taiwan HSR after its completion, the Executive Yuan had never considered leaving the major building job of the Taiwan HSR to the Taiwanese private sector in its 6-Year Plan.⁵⁵ Most of the key government reports, including the WT-HSR-FS, WT-HSR-GP and those visiting reports on the Shinkansen, TGV, ICE and AVE etc., revealed that all of those established HSR systems were built by their governments at the time.⁵⁶ It was very unlikely for Taiwan's private sector to be in charge of building the Taiwan HSR.⁵⁷

However, as noted, the 6-Year Plan had brought the Republic of China government a serious financial burden. Economic stagnation also brought a significant reduction in tax income to the Executive Yuan in the early 1990s.⁵⁸ In addition, according to Wen, Taiwan was going through a transformation from an authoritarian to democratic politics at the time. Taiwan's congress, the Legislative Yuan, first, had acquired more substantial power to check the administration since then, including its budgeting. Second, some governmental departments also began to argue with each other. They sometimes hardly reached a consensus on phenomenal projects, especially the Taiwan HSR project.⁵⁹ Moreover, some local capitalists, politicians and elites wanted more involvement in the policy process than they had in the 1980s and before.⁶⁰ As a result, the Taiwan HSR building policy was gradually switched from a pure government job to a project led by private investment.

⁵⁵ See *Economic Daily* "Economic Council Agrees to Build the Taiwan HSR: Might Privatize It in the Future," Mar. 1, 1990.

⁵⁶ See Institute of Transportation, Railway Reconstruction and POHSR, *West Taiwan High Speed Rail General Report and Visiting Report on the German and French HSR*.

⁵⁷ See an interview with Bernard Lozevis, director of the Taiwan branch of the French Gec-Alstom, in which he claimed that HSR projects were such huge infrastructures that they could only be done by governments. More detail at *Economic Daily*, "Foreign Experiences: Governments Directed HSR Projects," July 18, 1993.

⁵⁸ See Jenn-Hwan Wang, Chin-Ching Liu and Wen.

⁵⁹ See Wen, especially chapters 3 and 4.

⁶⁰ See Wen, especially chapters 5 and 6.

Right after the Economic Council argued the Taiwan HSR building policy with the Ministry of Finance in the Executive Yuan in 1991 and 1992, the Legislative Yuan in 1993 cut the Executive Yuan's Taiwan HSR project budget for the budgeting years of 1994 and 1995. The Legislative Yuan also made a resolution to the Executive Yuan at the time that the Taiwan HSR project shall be built mainly by private investment. The Executive Yuan thus seriously took the alternative option of encouraging private investment to build the Taiwan HSR into account and started working on planning its relevant policies. Finally, the Executive Yuan enacted a draft of the Statues for Encouragement of Transportation Infrastructure Projects. Later the statue was passed by the Legislative and came into force in December 1994.⁶¹

According to Wen, to the KMT administration, this policy change of who should build the Taiwan HSR would save the administration from a serious budgeting crisis and some struggles among different governmental agencies. It even solidified its political power since the KMT administration neither had to rule out the Taiwan HSR project nor to turn the majority of the Chinese/Taiwanese people down. To the congress, the Legislative Yuan could turn its previous subjective position to substantially check the administration through this project. Besides, it also intended to delegate some local power to join the project's planning. Finally, by earning themselves a leading role, local and private sector power were able to earn themselves more participation, profits and other interests.⁶²

The policy process by which the Taiwan HSR's construction work shifted from the government to private sector was far more complicated than I described above. Wen has well described and analyzed the details of the process. She also insightfully conceptualized this Taiwan HSR policy process as a result of the state transformation in the 1990s. She argues that

⁶¹ *Ibid.* The public knew that this statue was enacted exactly for the Taiwan HSR privatization policy. Also see POHSR *Taiwan HSR Construction Plan* and *Taiwan West Collider HSR Construction Plan*. Hsian-Ling Hu (胡湘麟), "The Case of Private Investment on Taiwan HSR Project," in *Proceedings of Rail Engineering Society of Taiwan (RESOT) Annual Meeting 2002* (Taipei: RESOT, 2002), 139~49.

⁶² See Wen, especially chapter 7.

this transformation in Taiwan mainly referred to those democratizing changes in terms of shifting political leadership. The KMT regime had been unable to dominate the administration, congress and the public after Lee took over both as president of the Republic of China and as KMT chairman. Lee combined together some political factions in the KMT regime and some other important local and economic power outside the KMT to resist those mainlanders who fled from China with the KMT in 1949. Briefly, there has been no determined power that, such as Chiang's leadership, could completely control how a public policy should be planned and what it should involve. Under the process of state transformation, therefore, although it lost some of the original rational planning thinking from the KMT technocrats, the Taiwan HSR policy showed a result of democratization. Wen thus came to the conclusion that the Taiwan HSR privatization policy was intertwined with several global, social, political, state, and capital activities triggered by democratization during the 1990s.⁶³

However, Wen's conceptualization focusing on actual state politics might undermine some deeper implications of the state transformation in 1990s Taiwan. Both democratization and indigenization characterized Taiwan's state transformation, but she overlooked the latter. In other words, staying focused on actual state politics might reveal little of what the Taiwan HSR project means to the majority of the Chinese/Taiwanese people and their homeland. Moreover, the political discourse making and shifting behind the state transformation would further entail those implicit but critical stories of how the majority of the Chinese/Taiwanese people perceived and conducted the most phenomenal project of the Taiwan HSR that they ever had in history. Rather than an institutional viewpoint from the state to policy-making, I apply the similar strategy of exploring Taiwan's engineering practice in previous chapters to investigate the politics of the Taiwan HSR project from local and cultural perspectives.

⁶³ Wen, 7-13.

4.2 Hybrid Identification Became Taiwanese Identification: From Dominance to Indigenization to Subjectivization

This significant cultural and psychological transformation in Taiwan resembles a similar process in Australia. Thirty or forty years ago many Australians referred to “going home,” meaning Great Britain, even if they had never been there. Now, no one says such things. Similarly, many Taiwanese once viewed China as the “homeland,” but very few hold that view...This change is reflected in the way Taiwanese now describe their culture. Previously, under the Chinese colonial regime, people said, “Taiwan culture is a subset of Chinese culture.” Now, people said, “Taiwan culture is a culture along with aboriginal cultures, Dutch culture, Spanish culture, Manchu culture, Japanese culture, and Western culture.”⁶⁴—J. Bruce Jacobs

Jacobs challenged the Chinese Nationalist (KMT) perceptions of Taiwanese history that Taiwan should be returned to the bosom of the Motherland or be viewed as an enemy territory to be occupied and exploited because the Taiwanese fought with the Japanese forces in China. He further argued that these perceptions were used to justify Chinese Nationalist colonial control over Taiwan.⁶⁵ As noted in chapter one, some Taiwanese intellectuals also preferred to view the KMT regime as a colonizer. How to position its political legitimacy with the majority of the people on the island of Taiwan is still a controversial issue. Nevertheless, the KMT regime’s policies of Chinese identity shaping could be detected clearly. For instance, they forced the Taiwanese to speak the ‘National Language’—Mandarin Chinese and fined and humiliated those

⁶⁴ J. Bruce Jacobs, “Taiwan’s Colonial History and Postcolonial Nationalism,” in *The “One China” Dilemma*, ed. Peter C. Y. Chow (NY: Palgrave Macmillan, 2008), 50~1.

⁶⁵ *Ibid.* Also see Jacobs, “Taiwanese and the Chinese Nationalists, 1937-1945: the Origin of Taiwan’s ‘Half-Mountain People’ (Banshan ren).” Steven E. Phillips, *Between Assimilation and Independence: The Taiwanese Encounter Nationalist China, 1945-1950* (Stanford, CA: Stanford University Press, 2003).

who spoke their traditional languages, such as Hokkien/Holo (福佬/鶴佬), Hakka (客家), Japanese or aboriginal languages. “The inculcation of a Chinese national identity went further than language policy. Time was also ‘nationalised’ by counting from 1912 as year one (when the Republic of China established)...Space was ‘nationalised’ with maps showing the national territory as including the whole Chinese mainland and Outer Mongolia. Streets were renamed after mainland places, while educational and cultural...were held to be the true successors to their mainland counterparts.”⁶⁶ “Consequently, Taiwanese children learned about all the rivers and mountains of China, and about Chinese political leaders, but they learned virtually nothing about their own history and geography.”⁶⁷ These KMT policies fabricated well a seamless discourse constructing the islanders’ Chinese identity.⁶⁸

On a parallel track, it is well known that the 1990s was the major period when democratization was initiated and developed in Taiwan. Moreover, it was also a time when the “Taiwanese” people was under construction in order to realize and solidify “their” democracy. They gradually understood that their island was their homeland. The people that lived on the island should be the community they depended on. The Taiwanese identity discourse had emerged. The decade of the 1990s therefore was also a time when the Taiwanese and Chinese identity discourses began to seriously compete with each other. Different Chinese and Taiwanese actors have been shaped and learned to participate and practice their public projects such as the Taiwan HSR project according to their different subjectivities.

Moreover, as one of the most remarkable projects in Taiwan’s history, the Taiwan HSR project in turn reflexively facilitated to stimulate and drive the competition. I will give a detailed discussion to explain what the notion of hybrid engineering is and how it was practiced by the

⁶⁶ Christopher Hughes, *Taiwan and Chinese Nationalism: National Identity and Status in International Society* (New York: Routledge, 2008), 29.

⁶⁷ Jacobs, “Taiwan’s Colonial History and Postcolonial Nationalism,” 44~5.

⁶⁸ See Hughes and Jacobs.

THSRC engineers in chapters five and six. Then I will argue that it was the engineering culture and tradition of hybridity embedded within the project that enabled it to carry out the competition between the Taiwanese/Chinese identity discourse in chapter seven. Taiwan's engineering culture has a larger significance in ways of constructing its culture along with Japanese culture, Western culture and others.

4.2.1 Activating the Taiwanese People, Discourse/Identity Making, and How the Taiwan HSR Came to be Desired in the Middle 1990s

Although Chiang's government did not favor the Super Rail, Lee and his premiers Hau and Lien listed the Taiwan HSR project in their 6-Year Plan and 12 Plans. The Super Rail and the Taiwan HSR project were not so different from each other in that they shared some similar engineering thinking and practices that I described in chapters two and three. In addition, they also shared some things in common in politics. Among other things, both the out-of-favor Super Rail and the approved Taiwan HSR were being decided for, but not by, the majority of the Taiwanese/Chinese people. In other words, the people had little substantial impact on and participation in the KMT regime's decision-making process of whether to build them or not.

As noted in chapter two, Hau, the third Chinese/mainlander premier of the Executive Yuan under Lee's presidency,⁶⁹ required that the Taiwan HSR policy be planned top-down instead of bottom-up in the government.⁷⁰ In other words, the Taiwan HSR should not just be a technocrat's rational project with economic and transport considerations only. Rather, it should carry some political vision in terms of national development as well. The Taiwan HSR project thus was planned to take some other visionary responsibilities at the time, such as facilitating to establish and balance eighteen life circles on the island of Taiwan.⁷¹ Even though he addressed his intentions to develop Taiwan for itself rather than for the preparation to reclaim control over

⁶⁹ See footnote 46.

⁷⁰ See chapter 2.

⁷¹ See *United Daily*, "Hau's Political Journey," July 17, 1993.

mainland China,⁷² Hau's political visions and top-down policy regarding the Taiwan HSR project still lacked any participation from the public.⁷³

Nevertheless, given the embedded political discourse of promoting a community economy within the 6-Year Plan, the discourse of the Taiwanese people was therefore placed in its core values and the Taiwan HSR project's as well. Basically, as Lee advocated, constructing a discourse of subjectivity would facilitate to build a new people of Taiwan. This subjectivatized people of Taiwan, if established, then would lead to a living community that he proposed.⁷⁴ Therefore, it appeared that the majority of the people of Taiwan were able to carry out their intentions to build a HSR for themselves since they were mentioned obviously in the 6-Year Plan. However, the people of Taiwan were still in the process of being formed. They thus were more like a symbol than a substantial actor in the framework of the 6-Year Plan policy. Although they were used as a symbol, the Lee government would be able to use this symbol to contrast itself from the past Chinese KMT government. As a result, these development plans, political discourses of subjectivity, the people of Taiwan and community economy etc. all together characterized the state transformation in Taiwan. This transformation could be not only conceptualized through democratization as Wen claimed but also with indigenization and subjectivization as I argue to highlight.

As noted, while the Super Rail was located in Chiang's dominant authoritarian-Chinese-KMT regime in the 1970s and 1980s, the Taiwan HSR project was generally getting through this regime's state transformation stage in the early 1990s. This transformation was full of political struggles. Even though he was president of the Republic of China and KMT chairman at the

⁷² See *Economic Daily*, "Everyday Topic: National Development Plan Not Necessary to Be Done in 6 Years," Jan. 14, 1991. Also see *United Daily*, "Re-claim Control over Mainland China: From Military Force to Political Means, Now the Time," June 21, 1989.

⁷³ See Legislative Yuan Gazette 80: 47 (1991): 233~4 http://lci.ly.gov.tw/lcew/index_5.zul Also see Wen, 6-5, 15.

⁷⁴ See Tzu-Hwa Huang (黃子華), "Teng-hui Lee's Political Thoughts and Policies," (PhD diss., National Taiwan University, 2004), chapter 4.

time, Lee was seen as the center of the political struggles during the transformation. Due to his Taiwanese, early Japanese and even short communist background, Lee's presidency and leadership raised serious challenges from most of the Chinese mainlanders who composed the KMT regime.⁷⁵ As a result, Lee not only had to gather the political power that supported his leadership within the KMT regime, but also sought other political resources and opportunities outside the KMT in order to resist most of those KMT mainlanders. The 6-Year Plan became one of Lee's most important policies to achieve his purpose of gathering political resources.

However, those political struggles in the early 1990s reflected a more fundamental controversy in terms of Taiwanese identity shifting/shaping during Lee's presidency from 1988 to 2000. It was likely that either the 6-Year Plan or the Taiwan HSR project might be like a practical tactic to earn Lee some political support and strength. Generally, most of the population that Lee met was imagining they were a part of the Chinese population in the late 1980s and early 1990s.⁷⁶ Lee thus continued to make his presidency connect to Chiang and the KMT's Chinese legacy in his first few years in office. Nevertheless, as his leadership became more stable and solid later, Lee intentionally advocated building a subjectivity of the Taiwanese.⁷⁷ His political discourses of "living community," "developing great Taiwan and building it as a new mother land (經營大台灣 建立新中原)," "Republic of China on Taiwan (中華民國在台灣)," "new Taiwanese (新台灣人)," and "special state-to-state relations between

⁷⁵ Chiang had implicitly identified Lee as the next national leader after the mid 1980s. See Tzu-Hwa Huang. Hughes. Jacobs, "One China, Diplomatic Isolation and a Separate Taiwan," in *China Rise, Taiwan's Dilemmas and International Peace*, ed. Edward Friedman (NY: Routledge, 2006), 85~109. Jacobs, "Taiwan's Colonial History and Postcolonial Nationalism." Cal Clark, "The Statehood of Taiwan: A Strange Case of Domestic Strength and International Challenge," in *The "One China" Dilemma*, ed. Peter C. Y. Chow (NY: Palgrave Macmillan, 2008), 81~96.

⁷⁶ See footnote 2 in chapter 1 and Chart 4.2.

⁷⁷ See Teng-hui Lee, *With the People Always in My Heart* (Taipei: Yuan-Liou Publishing Co., 1999). Teng-hui Lee, *The Road to Democracy: Taiwan's Pursuit of Identity* (Tokyo: PHP Institute Inc., 1999). Teng-hui Lee and Mineo Nakajima (中嶋嶺雄), *Asia's Intellectual Strategies (アジアの知略—日本は歴史と未来に自信を持って; 亞洲的智略)*, trans. Vincent Lo (駱文森) and Ming-Chu Yang (楊明珠) (Taipei: Yuan Liou Publishing Co., 2000). Teng-hui Lee and Yoshinori Kobayashi (小林善紀), *Teng-hui Lee School's Wisdom (李登輝學校の教え: 李登輝學校的教誨)*, trans. Tze-Ying Yang (楊子瑩) (Taipei: The Eurasia Publishing Group, 2001).

Taiwan and China (特殊兩國論)” were attempting to shape the Taiwanese subjectivity and draw a distinct line between the Taiwanese and Chinese more and more clearly over years in the 1990s.⁷⁸

Although the Democratic Progress Party (DPP; 民主進步黨) also was another very important local power, Lee was known as the most phenomenal leader in building the Taiwanese subjectivity. The DPP even showed some obsession over Lee’s leadership in the 1990s.⁷⁹ In other words, Lee dominated the discourse power of formulating and shaping the Taiwanese identity. He claimed the existence of the people of Taiwan. He also proposed to activate the people with democratization and indigenization. In short, Lee’s intentions were dedicated to lead the majority of the people of Taiwan to behave like a people with subjectivity and locality in the 1990s.⁸⁰

The Taiwan HSR project and even the 6-Year Plan and 12 Plans thus were not products proposed and shaped *by* the people of Taiwan, since the people was still under construction before the mid 1990s. However, the people was proposed as a critical symbol and value to separate the 6-Year Plan and 12 Plans from other earlier development plans in the Chinese authoritarian KMT regime, including the Ten Major Construction, 12 New Projects and 14 Major Plans. The 6-Year Plan and 12 Plans thus were more like parts of the political practices within the discourse making process of the people of Taiwan. It turned out that the people of Taiwan did emerge and significantly grow in the 1990s and they even have gradually distanced themselves from the Chinese identity over recent years. See Chart 4.2. Reports show that 26.2% of the population on the island of Taiwan claimed that they were Chinese in 1992, but the number dropped to only 4.4% in 2009. On the other side, while only 17.3% of the population

⁷⁸ *Ibid.* Also see Shih-Shan Henry Tsai.

⁷⁹ See Hui-Ying Chang, *Teng-hui Lee’s 12-Year Ruling 1988~2000* (Taipei: Commonwealth Publishing Co., Ltd., 2000), especially pages 62~9.

⁸⁰ See footnote 77.

identified themselves as Taiwanese in 1992, the number grew to 39.3% before the end of Lee's presidency in 2000. It even kept growing and reached 52.1% in 2009. In addition, the percentage of those self-identifying as both Taiwanese and Chinese has decreased from 50.9% to 39.2% over the years from the 1990s to the present. Although he was not the only power to activate and shape the people of Taiwan, Lee surely was one of the most important. He framed a political discourse that contained ideas of subjectivity, locality and democracy to establish a people of Taiwan. Lee's national development plans, including the 6-Year Plan and 12 Plans, thus appeared to be a means for the end of the political discourse of the Taiwanese.

Chart 4. 2 Changes in the Taiwanese/Chinese Identity of Taiwanese as Tracked in Surveys by the Election Study Center, National Chengchi University (1992~2009.06) (public domain)

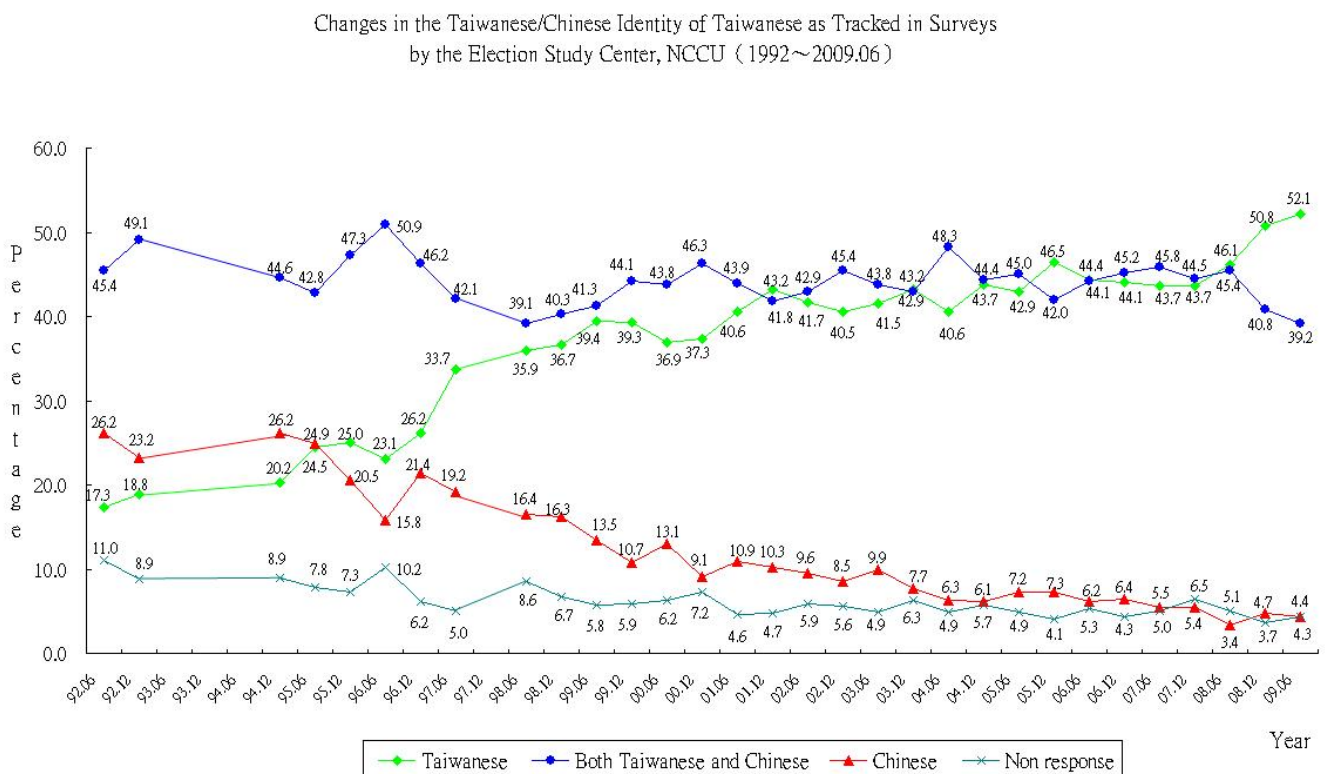

Source: Election Study Center, National Chengchi University

<http://esc.nccu.edu.tw/eng/data/data03.htm>

4.2.2 Taiwanese/Chinese Actors Struggled over the Taiwan HSR Project

While Lee and the DPP, among others, were activating and shaping the political discourse of the Taiwanese subjectivity and people in the 1990s, other different actors on the island of Taiwan not only learned but responded, reacted and participated in it. Some of them resisted this emerging Taiwanese discourse, especially among those with strong Chinese subjectivity,⁸¹ but a certain amount of local actors were motivated, allowed or willing to join the discourse making process. As noted, Lee was one of the most important leaders in the process; however, some other local actors who participated in the process were also playing an indispensable role like Lee and the DPP. Moreover, they had their own ways to participate and practice the Taiwanese discourse.

Similar to the idea of cannibalization, those different local actors constructed their subjectivities with the pieces and materials near them, especially under the overwhelming and dominant Chinese identity discourse in the early 1990s. They were disjointedly conducting a kind of identity discourse shift from a Chinese subjectivity to a Taiwanese subjectivity. This discourse shift, to some degree, might be like an advancing technology transfer in Taiwan, such as the HSR technology. Both included a core design from foreign makers or political leaders. Both also needed local engineers/actors to practice the introduced technology/discourse. As one of the most remarkable projects in Taiwanese history, the Taiwan HSR project might have been like a timely, continuous and critical platform for different Taiwanese actors to practice what they had, review who they were, and learn how to articulate what they wanted.

⁸¹ See Tzu-Hwa Huang.

I have shown in chapter three how the early government engineers designed and planned the Taiwan HSR with their engineering tradition and practices. They dedicated to *localizing* the Taiwan HSR project with their common engineering tradition shared among the Taiwan Railways and POHSR/BOHSR. Later, the THSRC engineers examined and upgraded the knowledge and practice of cannibalization to that of hybrid engineering. As noted, I will give a detailed discussion explaining the notion of hybrid engineering in the next two chapters. Therefore, the THSR was an appropriate project in terms of engineering scale and complication to represent the Taiwanese engineers' continuous training and practices. The THSR project was located at a time when the Taiwanese engineers were able to carry out the Taiwanese engineering culture of hybridity. Thus, rather than the point that, as Hood indicated, the Japanese have been emphasizing that the THSR is not another Shinkansen, the more important point is that the THSR is a Taiwanese HSR. In this and the next section, I argue further that the THSR project itself might have also been a timely opportunity for the Taiwanese people to *indigenize* their identity and build their subjectivity. Through the project, different Taiwanese actors regarded themselves and constructed their new relations with other actors and their government.

For some of the local people, their Taiwanese congressmen was one of the most important avenues to express their opinions, produce influences/pressures and even resist the POHSR's rational planning and Hau's top-down policy regarding the Taiwan HSR project. However, the local was often (mis)led by local congressmen as well. In either situation where local congressmen (mis)represented or (mis)led the local/voters, both the local and their congressmen participated in or resisted the Taiwan HSR project by beginning with regarding those local and individual interests near them. Thus, some significant and serious gaps between the administration and the local were usually seen in the project and several other policies in Taiwan

in the early 1990s. It appeared that while Lee's presidency was shaping a metaphysical people of Taiwan, different local policy actors were staying focused on their local interests. The Taiwan HSR project was a proper case showing how the majority of the people of Taiwan conducted democratization, indigenization and subjectivization between discourse making and local interests.

In order to explain those gaps between the administration and the local, a brief story about the change of the Taiwanese congress, the Legislative Yuan, might need to be brought in here. After six additional elections held from 1969 to 1989 in order to fill those seats occupied by the deceased mainland congressmen elected in 1948 China, the Second Legislative Yuan was elected by the Taiwanese population in 1992 according to the Additional Articles of the Constitution passed in 1991.⁸² This election was known as one of the most crucial steps in realizing and representing democratization in Taiwan. Although there were more Taiwanese congressmen than mainlander congressmen from the past elections, it was the Taiwanese congressmen's first time to fully control the Legislative Yuan. Along with other political revolutions,⁸³ the Taiwanese congressmen earned substantial power to delegate to the local people, check the administration and start imaging the Taiwanese as a people since then.

According to Wen, while the First Legislative Yuan questioned the Executive Yuan's Taiwan HSR policy based more on rational planning and transport efficiency and effects, the Second Legislative Yuan wanted to address more local and political issues, such as suggesting to extend or change the HSR route or to change the station location etc.⁸⁴ The congressmen of the Second Legislative Yuan not only represented the local supporters or opponents of the Taiwan HSR project in order to improve so-called local development,⁸⁵ but also for their individual

⁸² Legislative Yuan, "Concise History,"

http://www.ly.gov.tw/ly/en/01_introduce/01_introduce_02.jsp?ItemNO=EN020000

⁸³ See Shih-Shan Henry Tsai and Tzu-Hwa Huang.

⁸⁴ Wen, 6-16. Also see detail in Wen chapter 6.

⁸⁵ See Wen and Legislative Yuan, *Highspeed Trains*.

interests. It is well known that some local landowners could receive huge land compensation or other relevant interests from the project's affiliated programs of land acquisition and development.⁸⁶ Those congressmen and other political leaders from outside the Taipei metropolitan area especially spoke up for their interests.⁸⁷ Moreover, allegedly, some local congressmen even joined those programs seeking financial gain or other interests for themselves.⁸⁸ As a result, the Taiwan HSR project might have brought the people of Taiwan some developmental vision that the Executive Yuan advocated. In addition, its affiliated programs attracted a huge amount of attention from the public.

The key conflict of the Taiwan HSR project between the Executive Yuan and Legislative Yuan was, like the 6-Year Plan, its extraordinary budget cost. In 1993, the Executive Yuan planned to spend 426.6 billion NTD (16.17 billion USD) to build the Taiwan HSR, which did not include the loan interest of 138.2 billion NTD (5.24 USD) and this figure assumed it could be completed by 2000.⁸⁹ The required budget of the Taiwan HSR project was almost equal to 40% of the total amount of the central government's budget in 1994.⁹⁰ If the project were to be completed by 2003, then its total cost, including the interest, would reach 674.8 billion NTD (25.58 billion USD).⁹¹ Thus, the budget planning generated a lot of debate at the time. Actually, this financial conflict happened earlier within the Hau administration when his Ministry of Finance and Economic Council seriously argued where and how to acquire the project's budget in 1991.⁹²

⁸⁶ *Ibid.*

⁸⁷ See *United Daily*, "Five County Mayors Against HSR Planning Policy Change," June 24, 1991. *Central Daily*, "We Will Regret Tomorrow If We Don't Build the Taiwan HSR Today: Several County Representatives Advocated Organizing Pro Groups," July 20, 1993. *Central Daily*, "Southern Counties Protest the Taiwan HSR Budget Cut," July 25, 1993. *Central Daily*, "Save the Taiwan HSR Budget: Hsinchu, Chiayi and Tainan Protest," July 27, 1993.

⁸⁸ See Legislative Yuan, *Highspeed Trains*.

⁸⁹ POHSR, *Taiwan HSR Construction Plan*, 11~2. The annual average exchange rate was 1 USD equaled to 26.3819 NTD in the year of 1993. See Central Bank of the Republic of China (Taiwan)

<http://www.cbc.gov.tw/content.asp?CuItem=1879>

⁹⁰ The annual budget of the central government was around 1064.77 billion NTD. See

<http://win.dgbas.gov.tw/dgbas01/83ctab/83c101.htm>

⁹¹ See footnote 87.

⁹² See *United Daily*, "Wang, Minister of Ministry of Finance: No Money is a Fact," June, 4, 1991. *United Daily*, "Ministry of Finance Fights with Economic Council on the 6-Year Plan's Budget," June 5, 1991.

The Economic Council adamantly claimed that the Taiwan HSR project would not create a budget problem for the government since it could obtain loans from the private sector and pay them back over time. However, the Ministry of Finance insisted that the Taiwan HSR project would produce an enormous financial crisis for the government and it would be unable to recover from the huge burden in the near future.⁹³ Although he was inclined to adopt the Economic Council's account that money was not a critical problem,⁹⁴ Hau hesitated to solve this conflict between the Economic Council and Ministry of Finance. This conflict lasted until he stepped down in 1993.

After the Finance Minister, Chien-shien Wang (王建煊), resigned his position and then was elected as a congressman at the end of 1992, he was the key person who brought the controversial issue of the Taiwan HSR's budgeting plan in the Second Legislative Yuan. He later even led other congressmen to make the Legislative Yuan cut the whole HSR project's budget in the budgeting years of 1994 and 1995.⁹⁵ Wang was one of the few ministers whom Hau insisted to pick for his cabinet under Lee's presidency in 1990.⁹⁶ Like Hau, Wang was also known as one of the mainlanders who fled with the KMT regime from China in 1949. In addition, both Hau and Wang later had serious political conflicts with Lee and left the KMT mainly because of their conflicting thoughts over the Taiwanese/Chinese identity issue.⁹⁷ As a key person, Wang helped found the New Party in August 1993, which split from the KMT and mainly consisted of members with a strong Chinese identity. He was elected as a member of the

⁹³ *Ibid.*

⁹⁴ Pei-tsun Hau, "Public Television Interview on Dec. 4, 1992," in *Intrepidness* (Taipei: Wu-shi Publications, 1995), 368. Also see *United Daily*, "Hau: We Must Build Taiwan HSR," June 4, 1991. *United Nightly*, "Hau Repeat: Money Not a Problem to 6-Year Plan," June 7, 1991.

⁹⁵ See Legislative Yuan, *Legislative Yuan Important Days Volume 46: Second Legislative Yuan Section One and Two Year 1993* (Taipei: Legislative Yuan, 1994). Also see Wen, chapter 4.

⁹⁶ See *United Daily*, "Hau Directed Cabinet Personnel Arrangement," May 30, 1990. *United Daily*, "Wang Appointment Undermined Lee's Plan," May 30, 1990. *United Daily*, "Lee-Hau One-Year Inauguration: On Economic and Financial Policies," May 20, 1991.

⁹⁷ *Ibid.* Also see Ming-Tong Chen (陳明通), *Faction Politics and Political Changes in Taiwan (派系政治與台灣政治變遷)* (Taipei: Yue-Dan Publication, 1995), chapter 5.

Second Legislative Yuan in 1992 from Taipei City, which has been the nation's capital since 1949 and had more population with Chinese identity than most of the other cities in Taiwan.

Although Wang's Chinese identity was not the reason for his opposition to the Taiwan HSR project, it seemed that Lee might have taken advantage of this by creating conflict between the local Taiwanese and Chinese congressmen in the Second Legislative Yuan from 1993 to 1995. Along with other policies, Lee had no intention to alleviate these conflicts but to even generate more conflict between them, even though sometimes they both belonged to the KMT, chaired by Lee.

After Hau stepped down as premier of the Executive Yuan in 1993, Lee displayed an indifferent attitude toward the 6-Year Plan and the Taiwan HSR project although both were his policies. In the same year, during a meeting with the local Taiwanese congressmen, Lee expressed no clear intention to support the Taiwan HSR project or not.⁹⁸ It appeared that Lee was not speaking for his development policies when some serious conflicts regarding the Taiwan HSR policy had happened not only between the Executive Yuan and Second Legislative Yuan but also among several congressmen. Lee seemingly intended to allow these financial conflicts between the local Taiwanese and Chinese congressmen to be more visible in front of the people of Taiwan.

While he acted as a leader against the Taiwan HSR project in the Second Legislative Yuan, Wang also proposed to the Executive Yuan to build it by inviting private investment. He had suggested this since he was the Minister of Finance in 1990. As a result, according to Wen, the project was soon forced to be privatized not only about its future operation but also including its building work. She claimed that this policy change was an outcome of the democratization of Taiwan's state transformation at the time. The later actual political process is described in the

⁹⁸ See *Central Daily*, "Lee No Specific Stance to Build the Taiwan HSR or Not," July 21, 1993.

last section. However, here I argue that the privatization of the Taiwan HSR project can not be attributed to democratization only. The political discourse of the Taiwanese subjectivity and people and its indigenization also played important roles. The Taiwan HSR project might have been one of the key policies that deepened the differences and even conflicts between the Chinese and Taiwanese subjectivity and people since then. If Lee were to support the project and wield his leadership to advocate the policy the Taiwan HSR might have been done earlier. However, Lee seemed to let the Taiwan HSR policy struggle on for some years from 1993 until the project was handed over the THSRC in 1998.

4.2.3 Privatization Policy: An Outcome of Gaps between Core Discourse Design and Local Actors' Practices

After the Statutes for Encouragement of Transportation Infrastructure Project came into force at the end of 1994, it looked as if the Taiwan HSR privatization policy had finally reached a consensus in both the Legislative Yuan and Executive Yuan. As noted in the last section, Wen indicated that this policy would bring them a three-win situation. While the Second Legislative Yuan could fully demonstrate its power over the Executive Yuan, the KMT regime not only kept the project alive but also stabilized its political power after the authoritarian period. Moreover, the privatization policy could also prevent the Executive Yuan from incurring a huge financial burden. These wins were the outcomes attributed to the democratization process underway at the time. However, this privatization policy might have been overlooked if revisiting it through the perspective of subjectivity and people shaping. Among other things, how the local Taiwanese reacted to the Taiwan HSR project was one of the critical factors contributing to this privatization policy.

To some degree, during the privatization policy making process, a certain amount of the KMT's local Taiwanese congressmen and its other local actors lost some advantages in

comparison with the Chinese congressmen and policy actors at the level of policy planning. Those who expected to make a fortune from the land acquisition and development programs were singled out for criticism. Their explicit intentions to secure private and individual benefits through the Taiwan HSR project generated great hostility among the public.⁹⁹ Hau even publicly accused a few local representatives and politicians of attempting to extract unfair and unreasonable benefits from the project. In addition, one of the key reasons that Hau asked the POHSR to change the Taiwan HSR route planning and its station location was because he wanted to stop this notorious phenomenon.¹⁰⁰

The case of the Taiwan HSR project revealed that a certain number of local Taiwanese congressmen and politicians actually earned much less reputation than they should, even though they were growing in terms of numbers and political influence in the field of state politics. Their focus on private interests undermined their political influence. In the planning process of the Taiwan HSR policy, they could hardly compete with the professional Chinese elites nurtured by the authoritarian KMT regime, including those congressmen like Wang and some other technocrats. However, Lee needed the local KMT politicians to prevent his presidency and his discourse about the Taiwanese subjectivity to be jeopardized by the mainlanders in the KMT regime.¹⁰¹ In addition to its financial problem, therefore, all of the emerging local Taiwanese politicians, their over attention to local interests and Lee's discourse making were also a latent but key factor that facilitated the Taiwan HSR project to be privatized. They could offer no

⁹⁹ See *Tzu-Li Nightly* (自立晚報), "Government Should Plan Important Infrastructure Built on Public Land," May 27, 1993. *Chinatimes Nightly*, "Taiwan HSR Project and Land Tax Policy Needed Political Solutions," July 21, 1993. *The Common Daily*, "On Land Acquisition," July, 1993. *Economic Daily*, "Methods to Deal with Taiwan HSR Land Acquisition Problem," July 24, 1993. *Tzu-Li Daily* (自立早報), "Special Report for County Major Election 1993," Sep. 21, 1993.

¹⁰⁰ See *United Nightly*, "Hau Wants to Plan the Taiwan HSR from the Perspective of National Development," June 22, 1991. *United Nightly*, "Re-planning the Taiwan HSR, MOTC Minister: No Waste," June 22, 1991.

¹⁰¹ See Jenn-Hwan Wang and Ming-Tong Chen.

alternative to the privatization policy. Besides, neither could they stop the Chinese elites' rational planning nor gain public to support them.

The Taiwan HSR project in the 1990s was just one of several cases that characterized the local Taiwanese politicians and their policies. In the whole decade of the 1990s, Taiwan held national and local elections every year.¹⁰² After more and more local Taiwanese politicians were elected, more and more populism/consuming policies, such as some pension, compensation and national insurance programs, were proposed and implemented.¹⁰³ These policies not only deteriorated the government's finances, but also raised some serious policy tension between the local Taiwanese congressmen and the administration and Chinese congressmen.¹⁰⁴ The 1990s seemed to be a decade when the local Taiwanese searched for some national welfare that they did not receive during the Chinese KMT authoritarian period since World War II. They were still suspicious of the post Chiang KMT regime, including its administration and other Chinese actors, even though Lee had gradually solidified his presidency and political discourse. With Lee's motivation and the progress of democratization, for instance in the case of the Taiwan HSR policy, some of the local Taiwanese began to understand Taiwan by regarding themselves and their neighborhood since they had trouble involving themselves in the Chinese KMT regime before. Nevertheless, while they were able to address more local interests, the local Taiwanese policy actors sometimes possessed less professional capability in terms of policy planning than those mainland elites, such as in the case of the Taiwan HSR privatization policy.

Although they were not connected by a causal relationship, the Taiwan HSR project's early engineering tradition of hybridity and its privatization policy-making might share some things in

¹⁰² See the Database of the Central Election Committee <http://210.69.23.140/cec/cechead.asp>

¹⁰³ See *Economic Daily*, "Election Checks Writing Relentlessly, Who Is Willing to Save the Government Budgeting," Nov. 14, 1994. *United Daily*, "Ministry of Finance Minister: Congressmen Do Not Give People Illusions Please," Mar. 6, 1995. *United Daily*, "Congressmen Should Take More National Responsibilities," May 2, 1995.

¹⁰⁴ *Ibid.*

common in terms of practices. Both the Taiwanese engineers and politicians in the project displayed an indifferent attitude toward acquiring its core design of technology/discourse. Both conducted the project with the practices that they were familiar with. The key point that I indicate is there had been no phenomenal engineering/political entities shaped by the majority of the people of Taiwan before the 1990s. However, they have begun to construct their entities with the Taiwan HSR project together since then.

CHAPTER 5

LOCALIZED AND INHERITED ENGINEERING PRACTICE OF HYBRIDITY: THSR SPECIFICATION MAKING, CONSTRUCTION PLAN AND CIVIL CONSTRUCTION

After the THSRC officially took over the Taiwan HSR project in 1998, the Taiwan HSR project have revealed more and more delicate hybrid engineering planning, designs and constructions have been practiced and revealed than it had under the POHSR (from July 1990 to Jan. 1997)/BOHSR (since Jan. 1997) era. The early cannibalization experience that I described in chapter three has developed to mean a more specific engineering knowledge and practice that I term hybrid engineering in the fourth stage, from 1996 to the present. This was because the project was entering into the serious planning and building stage in which those early engineering practices were being examined and displayed more clearly and specifically. Moreover, the THSRC had incorporated substantially more Taiwanese engineers than had been included in the previous projects of the Super Railway, WT-HSR-FS, WT-HSR-GP and Taiwan HSR. More Taiwanese engineering thinking and practices flowed into the THSR project after more Taiwanese private sector engineers participated in it. I attempt to explain more in detail that the notion of hybrid engineering includes the specific practices of learning through collaboration and designing for inclusion that developed from the second and third stages in this chapter. In addition, the notion further includes the engineering practices of managing for mediation, engineering optimization and non-dependence that I attempt to discuss in the next chapter.

The THSRC was originally a consortium consisting mainly of five local private and leading engineering and construction companies.¹ Their engineers were associated with civil, electrical,

¹ They were the Continental Engineering Corporation (大陸工程), TECO Group (東元集團), Evergreen Group (長榮集團), Pacific Electric Wire & Cable Co. (太平洋電線電纜), and Fubon Group (富邦集團).

mechanical and aeronautical engineering and manufacturing, among other things. They brought their past experience into the THSR project. The THSRC has served as a useful microscope for observing and disclosing prominent and significant characteristics of the Taiwanese private sector's engineering practices. In addition, the THSRC has also inherited certain engineering designs and practices from the BOHSR. By observing the planning and building process of the THSR project, therefore, the engineering thinking and practices of hybridity were not exclusive to those official engineers in the POHSR/BOHSR, Institute of Transportation, MOTC and other governmental institutes. Those Taiwanese private sector's engineers were nurtured by and simultaneously developing and shaping an engineering culture that values hybridity as well. They and those official engineers shared and co-produced the phenomenon of hybrid engineering socialization and localization in Taiwan.

This chapter discusses what the THSRC's civil practices looked like in the THSR project. It argues that the THSR project has inherited the early Taiwanese hybrid engineering tradition instead of an engineering tradition limited to the government only. Moreover, this chapter argues that the idea of engineering inclusiveness was the core thinking behind both groups of engineers in the government and the private sector. Both groups managed for mediation among those different included engineering systems. In addition, international collaboration was an effective way to carry out hybrid thinking, practice and policy in the THSR project. Finally, they have led the THSR project not only to deviate from the Shinkansen and Euro-HSRs but also to create an independent and Taiwanese HSR.

5.1 Hybrid Strategies for Engineering Specification and Construction Plan Making

The BOHSR signed the THSR BOT contract with the THSRC on July 23, 1998. According to the contract, the THSRC was granted thirty five years as a concession period to run

the THSR and fifty years to develop the land surrounding some of its stations since then.²

Ching-Lung Liao, the first BOHSR Director-General, characterized this contract as a marriage contract since it required both the BOHSR and the THSRC to display strong and solid trust for maintaining such a long term relationship.³ As the chapter titled “Declarations, Commitments and Guarantees by the MOTC” in the contract stated, the BOHSR and THSRC should

act in a cooperative, trustworthy, fair and reasonable manner in fulfilling the contract. Both parties promise to settle disputes through negotiations and in consideration of each other’s rights and benefits while endeavoring to use the best of their efforts to avoid arbitration and litigation.⁴

Liao said these words were not legal terms but were actually borrowed from the idea of marriage.⁵ Both the BOHSR and THSRC intended to make their best effort to manage their relations and work out their conflicts and problems.

5.1.1 How Hybrid Thinking about Engineering Specification Making Passed from the BOHSR to the THSRC

In order to create a beneficial environment for the THSRC, the BOHSR had been trying to step back from their substantial task of making the THSR engineering designs and specifications after they signed the BOT contract. The BOHSR wanted the THSRC to build the THSR with as much engineering and management flexibility as possible. The THSRC was encouraged to choose which core HSR system would bring it the most profit, even though it still had to gain the

² BOHSR, “Taiwan South-North High Speed Rail Construction and Operation Contract,” in *Collection of THSR BOT Contract and Others* (Taipei: BOHSR, 1999), §4.1.1.

³ An interview with Ching-Lung Liao. Also see *United Daily*, “THSR Marriage: Create a Win-Win Scenario for Government and People with BOT Model,” July 26, 1998.

⁴ BOHSR, “Taiwan South-North High Speed Rail Construction and Operation Contract,” section 1. Also see BOHSR, “Information on the Contract to Build, Operate, and Transfer the Taiwan North-South High Speed Rail (HSR),” *HSR Newsletter* 3: 31 (1998), 8~12.

⁵ An interview with Ching-Lung Liao.

BOHSR's final agreement for that decision.⁶ The BOHSR allowed the THSRC to make its own engineering specifications and construction plan in order to benefit its business. As Fu-Hsiang Wu, the third BOHSR Director General, said "the BOHSR aimed to draw a clear line between it and the THSRC, and held those BOT principles adamantly."⁷

The above description seemed to be another story similar to the cases of transition from the Electrification Project to the Super Railway, from the Super Railway to the WT-HSR-FS, and from the WT-HSR-GP to the Taiwan HSR project among Taiwan Railways, the Institute of Transportation, the POHSR and the BOHSR as noted in chapter two. It seemed that there was also a break in terms of engineering design and construction plan between the Taiwan HSR project and the BOT THSR project. This transition from the government to a private company seemed to make the break even more obvious and significant. Most of the BOHSR's engineering designs for the Taiwan HSR project were not supposed to confine or even to force the THSRC in any way to realize its BOT THSR project. The BOHSR had to be open-minded with the THSRC's different engineering, management and business considerations.

Nevertheless, the BOHSR's early engineering thinking of hybridity persisted even after the THSRC took over the THSR project. Like those transitions that occurred between Taiwan Railways, the Institute of Transportation, the POHSR and the BOHSR, the break between the Taiwan HSR and the BOT THSR project was superficial in terms of engineering parameters and data. The THSRC still inherited a certain amount of the BOHSR's engineering designs. In addition, it even continued to practice the BOHSR's thinking about hybrid engineering but just in its own way. Basically, the THSRC did not have to build the best HSR in the world. Neither did it have to hybridize different HSR technologies and spend special effort making engineering

⁶ BOHSR, "Selection of HSR Mechanical & Electrical Systems," *HSR Newsletter* 4: 42 (1999): 7-8.

⁷ An interview with Fu-Hsiang Wu.

specifications. However, the THSRC still worked on integrating different HSR technologies, but it had its own way which was unlike that of the POHSR/BOHSR previously.

5.1.2 THSRC's Hybrid Engineering Specification Making and Construction Plan

While it received plenty of HSR engineering research and specifications from the BOHSR, the THSRC organized its own international engineering consulting group to design and conduct the THSR construction work. The THSRC ever directly hired more than 500 foreign engineers from 22 countries and 900 more local engineers during the construction period.⁸ At the time, it employed slightly more than two thousand professionals of all kinds in the company.⁹ Among the most prominent, the THSRC attracted some of the chief engineers and managers from the Channel Tunnel project and the Hong Kong Mass Transit Railway Corporation (Hong Kong Transit).¹⁰ The THSRC's intentions had been to make and manage the THSR's engineering specifications by itself instead of copying them from the Shinkansen, TGV or ICE systems.

Although it organized an international team to, among other things, manage engineering specifications for the THSR, the THSRC did not attempt to make them in a very detailed fashion. The THSR's Employer's Functional and Technical Requirements (Employer's Requirement) consisted of about fifty pages only, in which the THSRC intended to leave some gray areas for its downstream partners.¹¹ The THSRC thus looked like an engineering and construction

⁸ Fu-Hsiang Wu, "THSR New Records," E8-10. Also see Kuo-Yi Chang (張國儀), "Humble and Hard Working Engineer: Special Interview to an Alumnus Chung-Chun Kao (高聰忠), THSRC Senior Engineer," *Electrical Newsletter, Department of Civil Engineering, National Taiwan University* 5 (2008). <http://epaper.ce.ntu.edu.tw/vol.5/TCKao.html>

⁹ Tsao-Yi Wu (吳昭儀), "Behind the THSR Controversy," *Common Wealth* 320 (2005): 170.

¹⁰ An interview with Fu-Hsiang Wu. Also see *United News Daily*, "Chin-Der Ou (歐晉德; CEO of the THSRC): Foreign Vice General Managers Deigned," Sep. 25, 2009. For examples, the THSRC's current executive manager-general of the department of building and acquisition, Kuo-Hsiong Lee (李國雄) was the former chief engineer of Hong Kong Transit; its executive manager-general of the department of business operation, William Roger Donald (唐納德), was also Hong Kong Transit's chief director of business operation; another executive manager-general, Bernard Michael Fleming (傅廉明), was a world known lawyer. See THSRC, *2008 Annual Report* download at http://www.thsrc.com.tw/tc/about/ab_stock_download.asp. *Central News Agency*, "THSRC: High Paid Foreign Manager Earned International Competitively," Sep. 24, 2009.

¹¹ An interview with YW.

manager instead of a construction builder. It divided the THSR construction project into five major building projects: civil, track, station, depot and core HSR system projects.¹² Each of them was further subdivided into several minor projects of designs and construction.¹³ The THSRC then subcontracted these minor projects to other local and foreign manufacturers, companies or their joint ventures. In order to speed up the THSR construction, the THSRC even put its design and building jobs together in its civil, track and core HSR systems of the five major building projects.¹⁴ One thing worth noting was that, before they proceeded to break ground, those subcontractors not only had to make their detailed designs satisfy the THSRC's general engineering specifications but also to follow its process of design review. The THSRC might have had to become more involved with engineering specification making than its general specification making when reviewing those subcontractors' engineering proposals. The design and review process of the THSRC's civil work might be a good example to show what the THSRC did before the real building took place. See Figure 5.1 THSRC Civil Design Review Process. In order to be approved, any minor civil project's design needed to earn five agreements from the project's joint venture, its (contractor's) independence checking engineer (CICE), the THSRC's resident engineer (RE), independence checking engineer (ICE) and the THSRC itself.

Some of the THSRC engineers complained that their company's policies regarding general specification-making and minor project-subcontracting actually aimed to build the cheapest HSR instead of the best in the world.¹⁵ As I will show at greater length in later sections, the THSRC did make a significant effort to carry out the project as efficiently as possible. However, a more important message here was that these THSRC engineers needed to equip sufficient engineering

¹² See BOHSR, *Memorial Collection for the THSR Open to Traffic*, 12~5. BOHSR, *Current THSR Construction* (Taipei: 2005), 10~2. BOHSR, *Introduction to Full-span Precast & Launching Method* (Taipei: BOHSR, 2004), 3.

¹³ BOHSR, *Memorial Collection for the THSR Open to Traffic*, 72~3.

¹⁴ *Ibid* and BOHSR, *Introduction to Full-span Precast & Launching Method*, 16.

¹⁵ Interviews with the THSRC engineers.

knowledge and abilities in order to make and manage those engineering specifications and then hybridize some of the engineering designs and practices in order to achieve the greatest efficiency. To some degree, they even went further than the engineers in the government in terms of engineering hybridization, which I hope to show in the following sections and in the next chapter. The engineering culture that values hybridity has not been exclusive to the government but can be found in Taiwan's private sector.

Figure 5. 1 THSRC Civil Design Review Process (public domain)

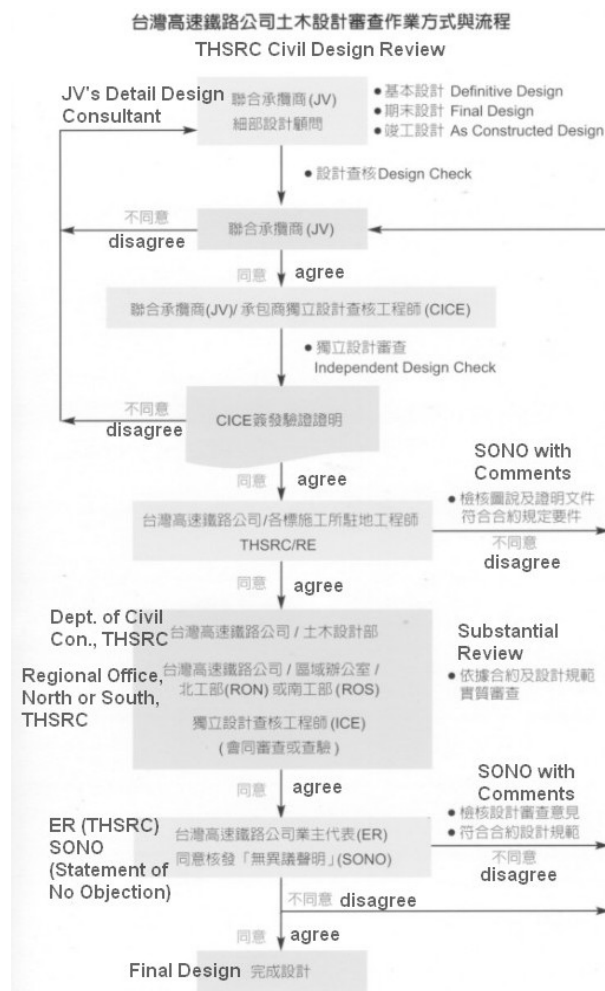

Source: BOHSR, *Introduction to Full-span Precast & Launching Method*, 17.

5.2 Localized and Inherited Engineering Practice of Hybridity: Civil Design and Construction

This section intends to show that the Taiwanese engineers, either in the POHSR/BOHSR or THSRC, had gradually attained substantial participation and even full control over the THSR's civil design and work. Unlike the Taiwan Railways before the 1980s, the POHSR/BOHSR in the early 1990s was able to get more substantial involvement in engineering designs for its Taiwan HSR project than those previous governmental agencies for other infrastructure projects. The THSRC even went further in using international resources and collaborations for its HSR designs and building work. In general, as both the current BOHSR Director General Ju and the former Dean of the College of Engineering at National Taiwan University Yung-Hsiang Chen (陳永祥) claimed in their interviews, this was mainly because Taiwan's engineering profession has improved significantly along with its economic growth since the 1970s. Civil engineering especially has stood out more than other engineering fields in Taiwan.¹⁶ In addition, Taiwanese civil engineers have gradually developed a unique way of how to do it. The THSR's civil designs and work, thus, might have displayed the most Taiwanese engineering characteristics. In short, the THSRC has been practicing the "localized" hybrid-civil-design and international-collaborative-construction in the THSR project.

5.2.1 THSRC Inherited the POHSR/BOHSR's Localized Civil Engineering Thinking

Generally they did not make concrete suggestions about civil specifications in their HSR visiting reports to France, Germany and Japan, but the POHSR made the decision to adopt more TGV and ICE's civil designs rather than Shinkansen ones in its WT-HSR-GP final report submitted to the Executive Yuan in October 1990. As noted in chapter three, while the U.S.-German joint consulting company Am-Dec was responsible for the WT-HSR-FS from 1989 to

¹⁶ Interviews with Yung-Hsiang Chen and Hsu Ju.

1990, the French SOFRERAIL was responsible for the WT-HSR-GP from 1990 to 1991. Both the Institute of Transportation and the POHSR participated substantially in and endorsed their final reports to the MOTC and Executive Yuan. Their endorsements were meaningful since they made some independent effort, such as those visiting trips, to understand HSR engineering at the time.

For example, during the second half of 1991, just exactly during the period between the WT-HSR-FS and WT-HSR-GP projects, the POHSR made their visiting trips with Railway Reconstruction to France, Germany and Japan. One of the conclusions in its TGV and ICE trips was that the THSR's civil designs and work would be no less important than its core system.¹⁷ In their TGV and ICE and Shinkansen visiting reports, the POHSR and Railway Reconstruction engineers clearly recorded and learned about their civil engineering specifications.¹⁸ The POHSR was not receiving engineering specifications in a passive fashion from foreign consultants only. Rather, it attempted to equip itself in order to participate in the WT-HSR-GP project and then reviewed its final report.

The former BOHSR Director General Fu-Hsiang Wu claimed that the POHSR/BOHSR had made around 80% of the civil engineering specifications for the THSR before the Taiwan HSR project shifted to the BOT model. Basically most of their civil specification making was based on the WT-HSR-GP report.¹⁹ As noted in chapter three, the BOHSR handed the report and its later engineering specifications over to the THSRC and China Development after they passed the first BOT bidding stage of quality review in early 1997.²⁰ This was one of the BOHSR's incentive strategies to attract private bidders to come and compete for the Taiwan HSR project,

¹⁷ POHSR, *Visiting Report on the German and French HSR*, 42.

¹⁸ *Ibid.*, 10~5. Also see Railway Reconstruction.

¹⁹ An interview with Fu-Hsiang Wu.

²⁰ BOHSR, "BOHSR Gives Briefings on Outcomes of HSR Detailed Design to Qualified Applicants," *HSR Newsletter* 1: 14 (1997): 6. BOHSR, "Incentive Negotiation with Qualified BOT Applicants," *HSR Newsletter* 1: 14 (1997): 8.

since those engineering specifications could help them make their business plans and future engineering designs. It turned out that the THSRC adopted some of them, especially regarding those THSR's civil designs.²¹ In other words, the THSRC inherited some of the BOHSR's engineering designs and even shared their thinking of hybrid engineering.

Generally, the French SOFRERAIL made the fundamental civil design for today's THSR. This was mainly because SOFRERAIL was in charge of the WT-HSR-GP project and later, as the following discussion shows, the THSRC has adopted some of its civil engineering specifications. However, as noted in chapter two, the POHSR also at the time invited the Japanese JARTS-HSR and German DE-Consult to be their special engineering consultants for the WT-HSR-GP project. Those civil engineering specifications, thus, were no copy of the French TGV's civil design. Both the Shinkansen and ICE's civil designs fit into the WT-HSR-GP's civil engineering suggestions as well. Actually, this was one of the WT-HSR-GP report's conclusions.²² The POHSR intended to include all the different HSR core systems to be able to be built and run on the Taiwan HSR's civil structure. Later on, the BOHSR and THSRC followed this POHSR's policy.

After it entered the building stage, as noted, the THSRC organized an international collaboration to help it build the THSR. "While there were 3,000 more Taiwanese engineers from over 1,200 local companies working with the THSRC, around 1,000 engineers from 80 more foreign companies came here to make a contribution for the THSR construction at the time."²³ According to its project scale in comparison with THSR's other four major constructions, most of these cooperative companies and engineers were participating in the THSR civil construction. The THSR has not only manifested a hybrid civil design but also an internationally collaborated construction. As a late born company in Taiwan, instead of being

²¹ *Ibid.*

²² See POHSR, *West Taiwan High Speed Rail General Planning, Final Report*.

²³ Fu-Hsiang Wu, "THSR New Records," E8-10.

forced by foreign power like Taiwan Railways in the past, the THSRC might have learned well how to introduce, manage and control resources from outside the island of Taiwan. In the end, the THSRC finished its civil construction within five years as it expected.²⁴ The following sections argue that the THSRC has exploited hybrid designs and international collaboration to achieve its goal of independence and efficiency.

5.2.2 Engineering Inclusiveness Comprised of Local Civil Design Thinking

Although the Executive Yuan made its final decision regarding the THSR's alignment in June 1992,²⁵ the POHSR/BOHSR still kept the WT-HSR-GP's HSR linear design that was made in 1991. The design dealt mainly with the radius of curvature, vertical and transition curves and the degree of vertical grade of the HSR railroad linear. Among other things, both the geological environment and the HSR engineering limitations would make different HSR linear designs. HSR's alignment planning was one of the important factors that determined what kind of geological environment it would be surrounded by. However, those different alignment proposals in the WT-HSR-FS and WT-HSR-GP reports had little impact on these linear engineering designs at the time.²⁶ The WT-HSR-GP's linear designs thus had not been significantly revised or adjusted even after the BOHSR turned the THSR project over to the THSRC in 1998. Even though it was not allowed to change the Executive Yuan's alignment policy according to the BOT contract,²⁷ the THSRC was welcome to design and build the THSR with its latest engineering considerations. Nevertheless, the THSRC not only inherited the Executive Yuan alignment but also most of the BOHSR's linear and civil engineering designs.

²⁴ See BOHSR, *Current THSR Construction*.

²⁵ BOHSR, *Memorial Collection for the THSR Open to Traffic*, 3.

²⁶ See Institute of Transportation, *West Taiwan High Speed Rail Feasibility Study, Final Report* and POHSR, *West Taiwan High Speed Rail General Planning, Final Report*.

²⁷ This was the Executive Yuan's policy. See BOHSR, "Taiwan South-North High Speed Rail Construction and Operation Contract."

As noted, it was the BOHSR's intention to leave the THSRC as much engineering flexibility as possible. However, the THSRC retained most of the BOHSR and WT-HSR-GP's linear and civil engineering designs. Table 5.1 reveals that today the THSR's civil designs show no significant difference from those in the WT-HSR-GP report. The THSRC kept the WT-HSR-GP report's linear design parameters for the minimum radius of curvature, maximum slope grade and vertical curve etc. Both adopted 6,205 and 5,500 meters as the general and minimum radius of curvature. They were longer than those of the other HSRs mainly because the THSR was intended to reach the faster speed of 350 km/hr, as opposed to their speed of 300km/hr or less. The faster the HSR rolling stock is the longer the minimum radius of curvature that is required. This principle generally applies to the designs of the HSR maximum slope grade and vertical curve as well. It appears that both the THSRC and WT-HSR-GP had relatively larger parameters than those of the other HSRs.

In addition, the THSRC only slightly changed the WT-HSR-GP's designs for civil structures such as the section size of tunnels, viaduct width and distance between track centers. Both Ching-Lung Liao and Fu-Hsiang Wu thus claimed that the BOHSR had done most of the THSR's linear and civil specification making for the THSRC at the time.²⁸ However, the WT-HSR-GP report was completed almost a decade before the THSRC built the THSR. As noted, HSR technology has been improving rapidly over time. The THSRC could have made some adjustments or even made some revisions to those civil designs in the WT-HSR-GP report. Nevertheless, like the POHSR/BOHSR, the THSRC placed more emphasis on engineering inclusiveness rather than engineering improvement in the aspects of the THSR civil design.

Table 5.1 shows the civil engineering specifications for the HSR systems before 1991 and of the THSR completed in 2007. While the WT-HSR-FS parameters and designs made by Am-

²⁸ Interviews with Ching-Lung Liao and Fu-Hsiang Wu.

Dec were generally somewhere in between the Tōhoku and Jōetsu Shinkansen lines and the TGV's, those of the WT-HSR-GP designed by SOFRERAIL were in between the TGV and ICE's. It looked as if they tended to be more like the European style rather than the Japanese. Or more specifically, today's THSR linear and civil designs seem to show more of the ICE's engineering design than the other two.

However, the more important message revealed in Table 5.1 was that most of those civil parameters and designs in the WT-HSR-GP report and today's THSR could fit with the engineering requirements of the Shinkansen, TGV and ICE core systems. In general, compared with the Shinkansen and TGV, the intentions of the POHSR/BOHSR and THSRC have been to allow their THSR rolling stock to run on a smoother linear design and a more spacious civil structure like the ICE. As noted in chapter two, Ping Tong revealed this similar intention in his visiting reports and during the interview as well.

Basically, the speed of the HSR rolling stocks seemed to be the HSR engineers' highest priority engineering consideration for its linear and civil designs, but speed alone was insufficient to explain all of them. Generally, the faster the HSR rolling stocks, especially for speeds over 200 km/hr, the more dramatically the ground and rolling stocks' running vibrations increase.²⁹ The HSRs thus need a more spacious civil structure and a smoother linear than conventional railways. More specifically, the HSR civil construction requires, among other things, larger tunnels, wider railroad beds, a longer radius and vertical curves etc.

However, one of the interesting points here was that the Shinkansen, TGV and ICE were all able to reach their business speed of around 300 km/hr in the late 1990s, but their civil designs still retained some significant differences among them. In other words, it was not just the speed of the rolling stocks that determined the HSR's civil structure designs. HSRs have been known

²⁹ Yung-Hsiang Chen *et al*, *HSR Vibration Study: Final Report* (Taipei: BOHSR, 2001), III.

as a growing technology in terms of ongoing improvement over time. Their engineering designs and conditions are usually intertwined with each other at one moment. No design or condition was absolutely decisive over the others. Therefore, for example, the Shinkansen has overcome some civil difficulties with other technologies while its speed increased. However, the POHSR/BOHSR and THSRC engineers had their different engineering considerations for the THSR's linear and civil designs.

Although this should be a byproduct instead of their original intention, it appeared that the POHSR/BOHSR and THSRC have been seeking better amenities for passengers on the running rolling stocks. A longer linear and larger civil design would be one of the most important factors contributing to passengers' comfort. Some of the BOHSR and THSRC's engineers have claimed that today's THSR might have provided the most comfortable HSR travel experience in terms of the running-train stability in the world. This is mainly because the THSR's passengers sit on the Japanese rolling stocks that run on the European HSR linear designs.³⁰ While the Shinkansen rolling stocks carry longer, wider and more air-tight trains than the other two, the European civil and linear designs offer longer radius curves and a wider distance between tracks than the Shinkansen. See rolling stock design parameters in Table 5.1. These characteristics contributed to increase the stability of the running HSR rolling stock. The THSR passengers thus have gained better engineering comfort than with the Shinkansen, TGV and ICE. However, this comfort outcome should be a byproduct instead of the Taiwanese engineers' original intentions. The Taiwanese HSR engineers were more interested in creating the most competitive bidding environment where Taiwan could get the most advantage from it. Therefore, they, either in the POHSR/BOHSR or THSRC, chose to adopt more of the European HSR civil design than from the Shinkansen.

³⁰ Interviews with the BOHSR and THSRC engineers.

Basically, most of the different THSR civil designs evolved similarly from the WT-HSR-FS project to the THSR project. Most of these design parameters had been changing over time, but they changed in a certain pattern. That was, they gradually deviated from the Japanese design in the beginning and then moved towards the European design later. This was because one of the official Taiwanese engineers' intentions was to invite all potential HSR technology providers to bid for the Taiwan HSR project. Moreover, they believed, just as Ping Tong did, that it was possible for them to integrate any one of the HSR core technologies into another different HSR civil engineering design. One of the POHSR's engineering policies under Director General Chung-Yih Lin's (林崇一) leadership, during the period from March 1993 to August 1996, was to dedicate more of its major engineering work to civil designs than to the core system.³¹

Rather than referring the THSR's linear and civil designs to the European or German style, it should be the Taiwanese official engineers' intentional considerations of including those engineering designs able to fit into and integrate with all possible HSR core systems. They calculated what civil designs might benefit the Taiwan HSR project the most. The European or German civil design thus was favored mainly because of the Taiwanese engineers' intention of engineering inclusiveness.

Table 5. 1 Civil Engineering Specifications of WT-HSR-FS, WT-HSR-GP, and Shinkansen, TGV and ICE before 1991, and THSR in 2007 (public domain and used under fair use guidelines)

HSRs Specifications	Shinkansen			WT-HSR-FS (Mar. 1990)	WT-HSR-GP (Oct. 1991)	TGV (Southeast 1981) (Atlantic 1989)	ICE (Mannheim —Stuttgart) (1991)	THSR (Jan. 2007)
	Tōkaidō (1964)	Sanyō (1972)	Tōhoku /Jōetsu (1982)					
Max. (Original) Designed Speed (km/h)	210	260	260	300	350	300 515 (max.)	280 406 (max.)	350

³¹ Interviews with Ching-Lung Liao and Fu-Hsiang Wu. Also see *United Daily*, "New MOTC Policy: Core System Prior to Civil Planning," June 28, 1996. *Economic Daily*, "Chung-Yih Lin Stepped down," Aug. 12, 1996. *United Daily*, "MOTC Wants Ching-Lung Liao to Take Over." Aug. 13, 1996.

HSRs Specifications	Shinkansen			WT-HSR-FS (Mar. 1990)	WT-HSR-GP (Oct. 1991)	TGV (Southeast 1981) (Atlantic 1989)	ICE (Mannheim —Stuttgart) (1991)	THSR (Jan. 2007)
	Tōkaidō (1964)	Sanyō (1972)	Tōhoku /Jōetsu (1982)					
Max. Business Speed (km/h)	270	300	275/245		300	300	280	300
Min. radius of curvature (m)	2,500	4,000	4,000	4,000	6,250 (general) 5,500 (min.)	4,500	5,100	6,250 (general) 5,500 (min.)
Max. Slope Grade (‰)	20	15	15	35	25 (general) 35 (limited to 4.0+ km)	35 (Southeast) 25 (Atlantic)	40	25 35 (max.)
Vertical Curve Radius (m)	10,000	15,000	15,000	16,000	25,000 19,300 (min.)			25,000
Transition Curve								Sine Half Diminishing Curve/ Clothoid Curve
Cross Sectional Area of Tunnels (m ²)	62	64	64	> 64, <100	100	63/83/100 at 230/270/300 (km/hr)	82/94 at 250/300(km/ hr)	90
Width of Precast Box Girders (m)	10.9	11.5	11.6	11.0	12.9	11.50~12.09 (Southeast) 12 (Atlantic)	14.3	13.0
Span of Precast Box Girder Bridge (m)					20~30	30		30~35
Viaduct Structure	Rigid Frame with Precast Box Girders				Continuous Beam Pillars with Precast Box Girders		Simple Beam Pillars with Precast Box Girders	Continuous Beam Pillars with Precast Box Girders
Expiration of Main Viaduct Structure (years)					100			100
Speed Limit of Main Viaduct Structure (km/hr)					350			350

Sources: Organizing from the following sources: Institute of Transportation, *West Taiwan High Speed Rail Feasibility Study, Final Report*; POHSR, *West Taiwan High Speed Rail General Planning, Final Report and Visiting Report on the German and French HSR*. Railway Reconstruction, *Visiting Report on the Japanese Shinkansen: Planning, Design, Build and Operation*. POHSR, “Introduction to West Taiwan Collider HSR Construction Plan” and

Taiwan HSR Construction Plan. BOHSR, “Rolling Stock System (1),” *HSR Newsletter* 1: 18 (1997), 7~8. BOHSR, “Conclusions,” *HSR Newsletter* 1: 24 (1998), 8. Li-Xin Chien (錢立新) ed., *World HSR Technologies* (Beijing, China: China Railway Publication, 2003). BOHSR, “Main Specifications of HSR Model 700T Train,” *HSR Newsletter* 8: 97 (2004), 3~4. BOHSR, *Introduction to Full-span Precast and Launching Method*. Christopher Hood, *Shinkansen: From Bullet Train to Symbol of Modern Japan*. BOHSR, *Introduction to Railroad Engineering and Construction* (Taipei: BOHSR, 2006). BOHSR, *Introduction to New Austrian Tunnel Method* (Taipei: BOHSR, 2005). BOHSR, *Introduction to the THSR Electrical and Mechanical Engineering and System* (Taipei: BOHSR 2008).

5.2.3 Engineering Inclusiveness Brought Engineering Creativity and Hybridization

Although the THSR’s tunnel size in the WT-HSR-FS was already proposed to be larger than any one of the opened Shinkansen lines at the time (including the Tōkaidō (open to traffic in 1964), Sanyō (1972), Tōhoku (東北; 1982) and Jōetsu (上越; 1982) lines),³² one year later the WT-HSR-GP report still recommended to design an even larger tunnel size than that of the WT-HSR-FS report. As noted, during the time in between the projects of the WT-HSR-FS and WT-HSR-GP, the POHSR and Railway Reconstruction engineers went to visit the TGV, ICE and Shinkansen. One of the important observations contained in their reports was that both the TGV and ICE had similar scale design of their tunnels. In addition, they were significantly larger than those opened Shinkansen lines’ tunnels. See Figure 5.2, 5.3, 5.4, 5.5 and 5.6. Although they did not indicate clearly what tunnel size they suggested for the Taiwan HSR in their visiting reports,

³² The Sanyō and Tōhoku lines have expanded in terms of distance over the years. The Sanyō’s full completion was in 1985 and the Tōhoku’s latest entailment was in 2002. In addition, they and the Jōetsu lines also added new stations over time. The Nagano (長野) line was open to traffic in 1997 and the Kyūshū (九州) line first stage in 2004. Other than the main lines, there are some mini Shinkansen lines. They were converted from conventional railways to semi-Shinkansen in terms of gauge, signaling system upgrades and others. Mini Shinkansen lines are allowed to run Shinkansen rolling stock but unable to reach the same high speed on the main lines. See Hood, especially appendix I and II.

those POHSR and Railway Reconstruction engineers agreed and endorsed the WT-HSR-GP's conclusion of adopting the ICE and TGV tunnel design a few months later in 1990.

Figure 5. 2 WT-HSR-GP Tunnel Design (public domain)



Source: POHSR, *West Taiwan High Speed Rail General Planning, Final Report*, 6-24.

Figure 5. 3 Shinkansen (Tōkaidō and Sanyō Lines) Tunnel Design (used under fair use guidelines)

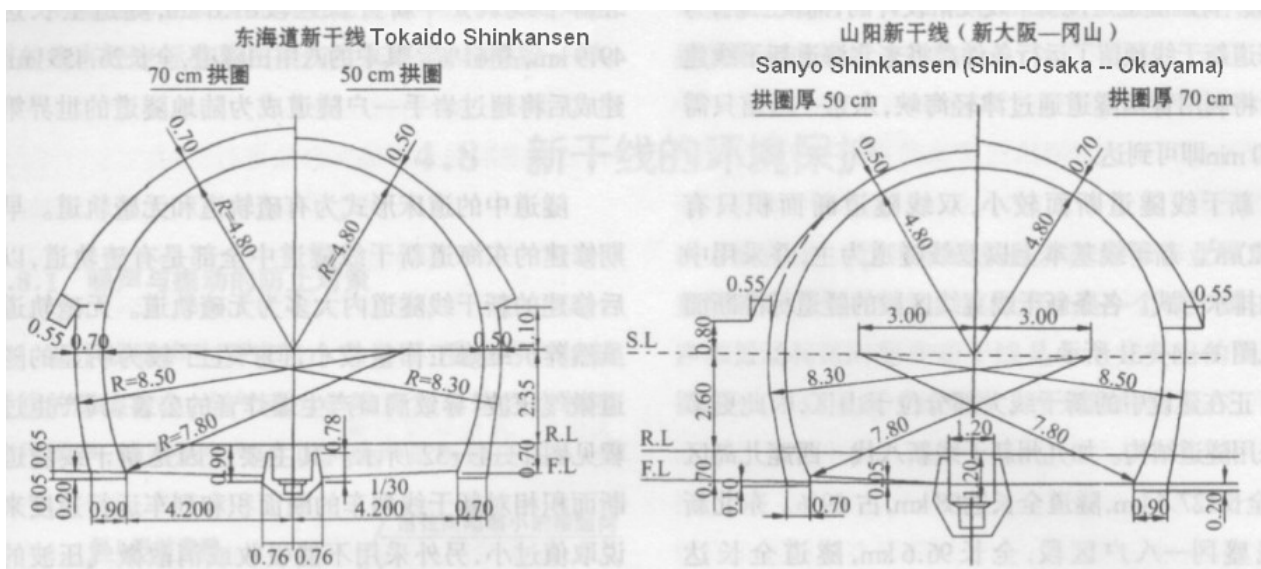

Source: Rail Reconstruction, 43 and Chien ed., 89.

Figure 5. 4 TGV (Atlantic Line) Vouvray Tunnel Design (used under fair use guidelines)

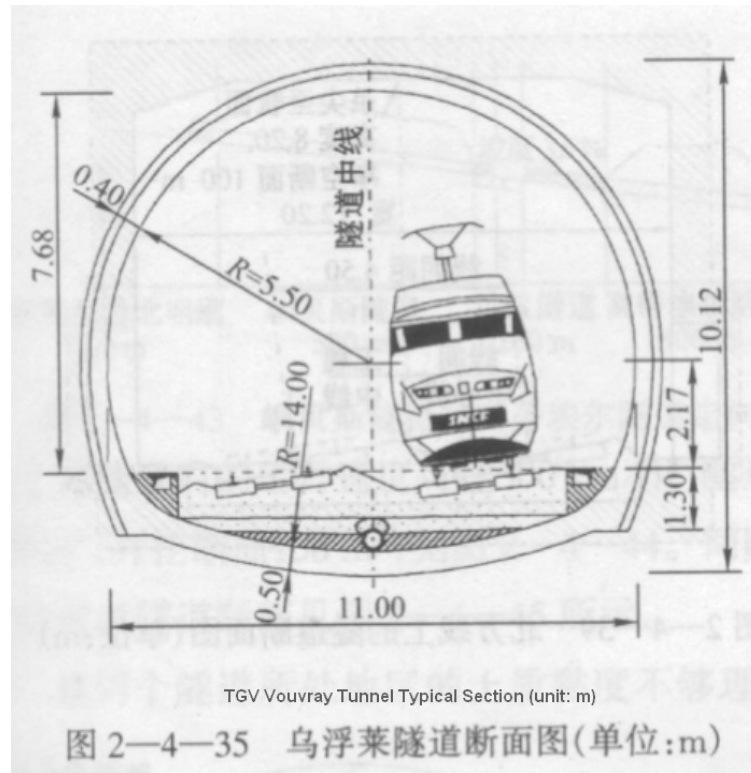

Source: Chien ed., 341.

Figure 5. 5 ICE (Mannheim—Stuttgart) Tunnel Design (used under fair use guidelines)

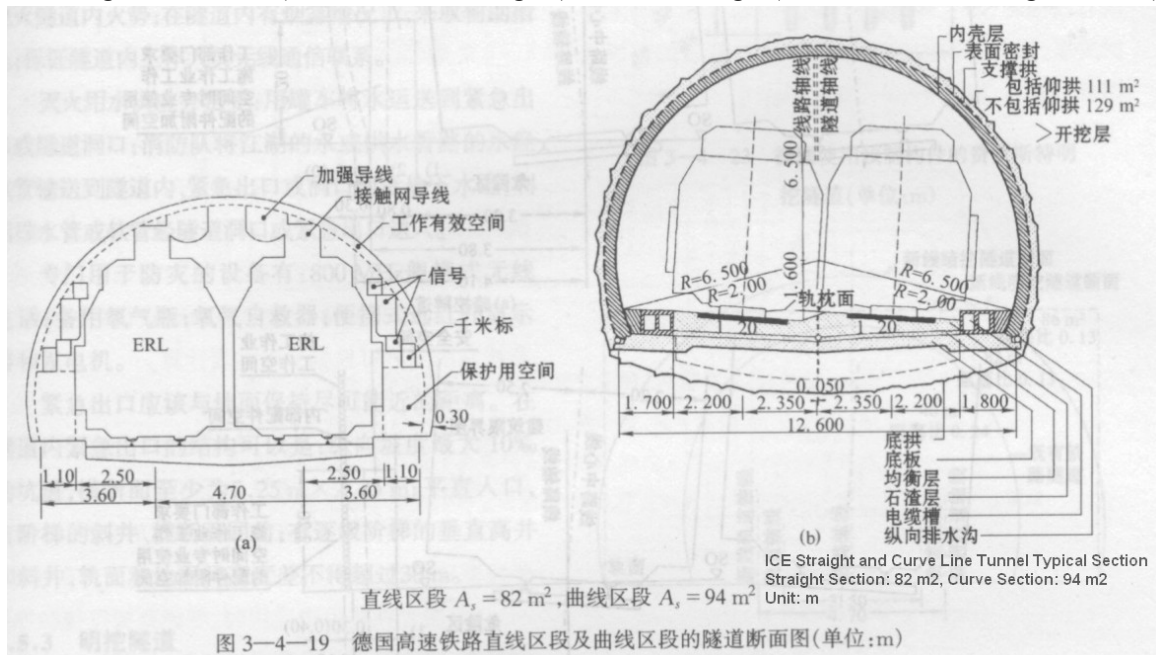

Source: Chien ed., 523.

Figure 5. 6 THSR Tunnel Design (public domain)

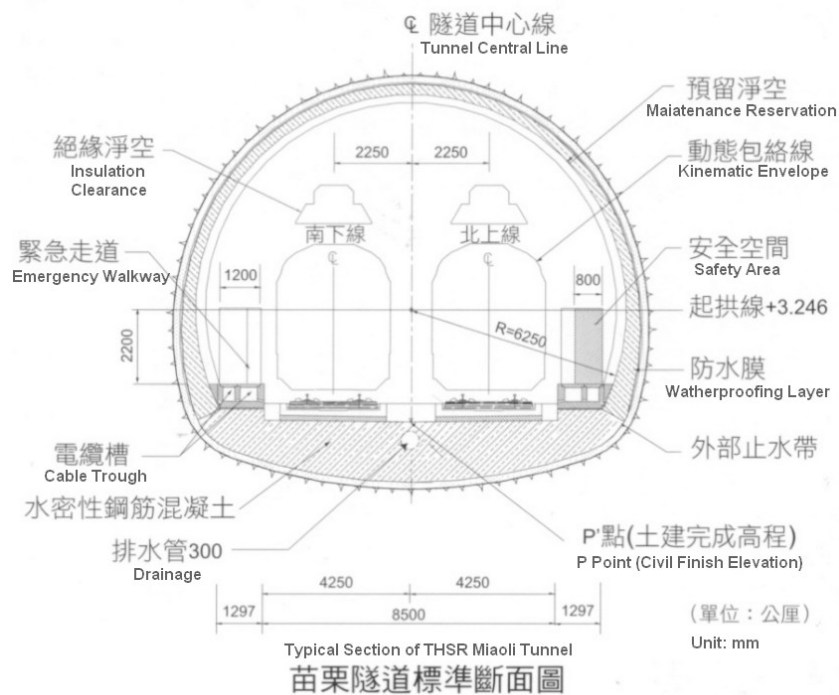

Source: BOHSR, *Introduction to New Austrian Tunnel Method*, 202.

While those opened Shinkansen lines' trains run through their tunnels with the typical section area of 64 m^2 ,³³ the WT-HSR-GP suggested the Taiwan HSR's tunnels be 100 m^2 .³⁴ The TGV, ICE and WT-HSR-FS's tunnel sectional area designs were somewhere in between 64 m^2 and 100 m^2 . The TGV designs were divided into three different tunnel sizes of 63 m^2 , 83 m^2 and 100 m^2 while its trains' maximum speed reached up to 230 km/hr, 270 km/hr and 300 km/hr respectively.³⁵ The ICE design was similar with the TGV, 82 m^2 for 250 km/hr and 94 m^2 for 300 km/hr.³⁶ Generally, the faster the HSR trains, the larger the tunnels would need to be. This is mainly because the larger the tunnel size the smaller the sonic boom and air pressure that the HSR trains would produce. The sonic boom and heavy air-pressure might damage the running

³³ Chien ed., 89~91. Also see Railway Reconstruction, *Visiting Report on the Japanese Shinkansen: Planning, Design, Build and Operation*.

³⁴ POHSR, *West Taiwan High Speed Rail General Planning, Final Report*, 6-24.

³⁵ Chien ed., 340.

³⁶ Chien ed., 523.

trains and tunnel structure. They might also make passengers uncomfortable in terms of instant tinnitus.³⁷ See Figure 5.7 Micro Pressure Wave Phenomenon. Figure 5.8 Correlate Relations of Tunnel Air Pressure and Tunnel Section Size. However, enlarging the HSR tunnel size was not the only option for reducing the sonic boom and heavy air-pressure. Beveled tunnel exits could effectively alleviate these destructive phenomena as well.³⁸ For example, the THSRC designed its tunnel exits with an angle of 45° if the tunnel was longer than 3 km.³⁹ See Figure 5.9 THSR Tunnel Entrance/Exit. Besides, tunnel enlargement construction would cost much more than some other possible solutions.

Figure 5. 7 Micro Pressure Wave Phenomenon (used under fair use guidelines)

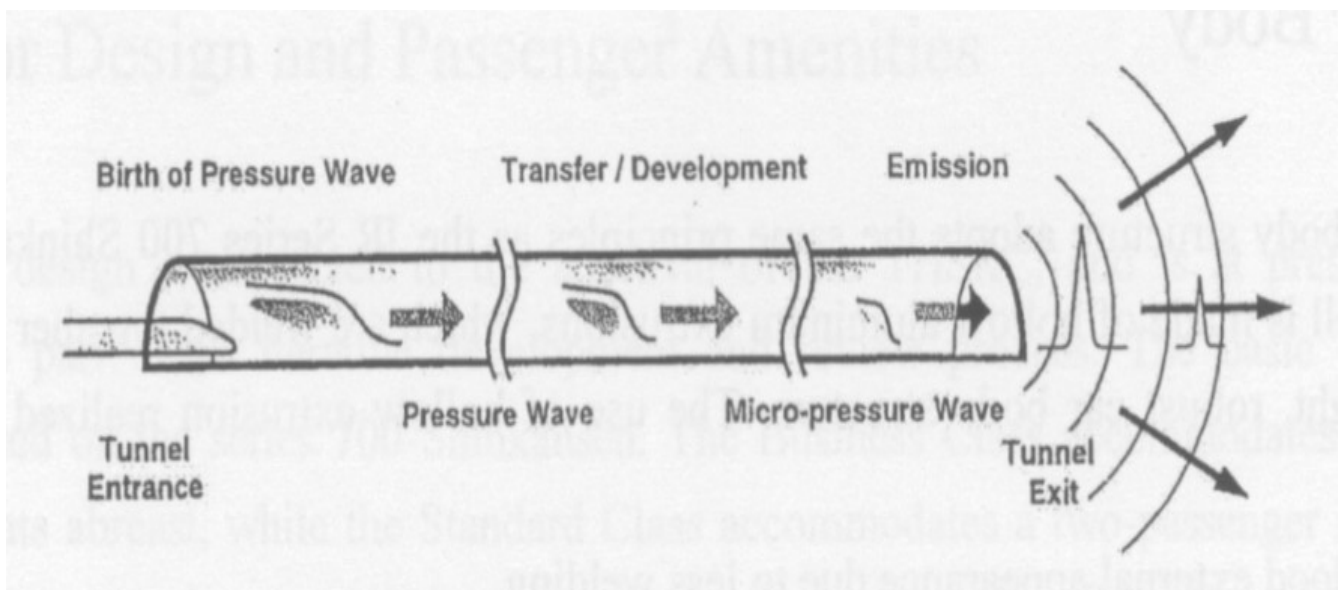

Source: Masashi Ishizuka, 97.

³⁷ See National Center for High-performance Computing, *Research Report on Micro Pressure Wave in HSR Tunnels* (Taipei: BOHSR, 1998). Chien ed., 90 and 522. POHSR, *West Taiwan High Speed Rail General Planning, Final Report*, 6-19~21. Also see *United Daily*, "Jpn or Euro Core HSR System: Which fits Taiwan's Most Needs," June 28, 1999. According to the WT-HSR-GP report, HSR passengers would be seriously hurt if the air pressure instantly reaches 8000 Pa/sec. They would feel uncomfortable if the pressure went up to 400 Pa/sec.

³⁸ Chien ed., 90 and 522. Building ventilation shafts would be another effective method to reduce the sonic boom and heavy air-pressure.

³⁹ BOHSR, *Introduction to New Austrian Tunnel Method*, 3.

Figure 5.8 Correlated Relations of Tunnel Air Pressure and Tunnel Section Size (public domain)

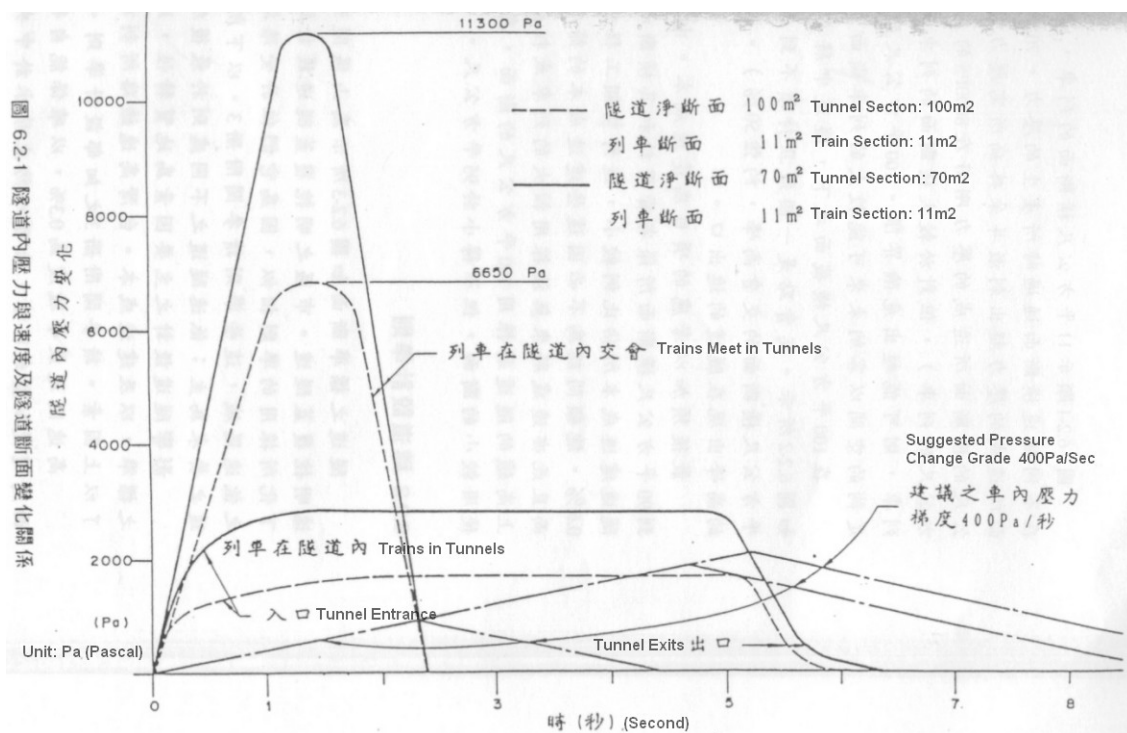

Source: POHSR, *West Taiwan High Speed Rail General Planning, Final Report*, 6-21.

The Japanese overcame some of the impacts of the sonic boom and heavy air-pressure on their rolling stock by, among other things, advancing their fluid and air-tightness designs.⁴⁰ The sharper and longer the first train's front nose, the smaller the air wave the HSR rolling stocks produced.⁴¹ See Figure 5.10 Shinkansen 700S Rolling Stock and Figure 5.11 THSR 700T Rolling Stock. In addition, the better the rolling stocks' air tightness, the smaller the tinnitus the passengers would confront. It also helped to protect the rolling stock from damage created by air pressure change. Therefore, train speed does not determine the size of tunnels; other civil designs and rolling stock technologies could also help to reduce those air-pressure problems. The Japanese saved a certain amount of the budget for constructing larger tunnels.⁴² However,

⁴⁰ POHSR, *West Taiwan High Speed Rail General Planning, Final Report*, 6-19~21.

⁴¹ See Masashi Ishizuka, "The Rolling Stock for Taiwan High Speed Rail," in *Proceedings of Rail Engineering Society of Taiwan (RESOT) Annual Meeting 2002* (Taipei: RESOT, 2002), 93~105.

⁴² Chien ed., 90~1.

those designs might not be able to remove all of the problems. The Shinkansen might still have to sacrifice some passenger comfort from the European perspective.

Figure 5. 9 THSR Tunnel Entrance/Exit (public domain)

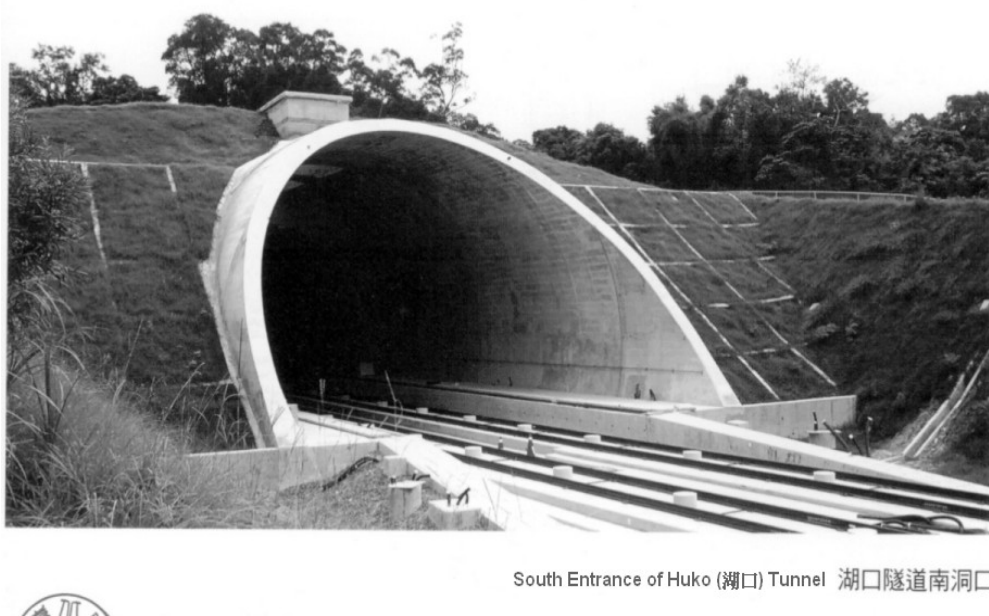

Source: BOHSR, *Introduction to New Austrian Tunnel Method*, 25.

Both the WT-HSR-FS and WT-HSR-GP reports proposed the adoption of a larger size of tunnel design for the Taiwan HSR. It was even the largest design, 100 m², at the time. This was not just because those reports were made by the non-Japanese HSR consultants (the Am-Dec and SOFRERAIL). Rather, this civil engineering suggestion was more likely to be the Taiwanese engineers' decision as well because, as noted, they had always wanted to allow for the possibility of all major HSR core technology suppliers bidding on the Taiwan HSR in the future. This had been one of their most important considerations when they made their engineering suggestions and decisions.

This POHSR/BOHSR policy that intended to invite all HSR technologies was also one of the major factors that made the POHSR stay focused more on the civil specification-making

rather than the electrical and mechanical engineering systems (the core HSR systems, in other words). As a result, Chung-Yih Lin was seriously criticized by the MOTC because this preference policy delayed the Taiwan HSR project in 1996.⁴³ Anyhow, rather than being a political conflict between Chung-Yih Lin and Chao-Yang Tsai (蔡兆陽; the Minister of the MOTC at the time) as was described in newspapers, this preference policy of inviting international competition as much as possible was explicitly seen in the WT-HSR-FS and WT-HSR-GP projects in the late 1980s and early 1990s. Furthermore, this preference could be traced back to Taiwan Railways' Super Railway project in the 1970s, in which two different Shinkansen lines and the TGV were all included as potential sources for being integrated and introduced to Taiwan.

Figure 5. 10 Shinkansen 700S Rolling Stock

Copyrighted by Nippon Sharyo, Ltd.

View the figure at <http://www.n-sharyo.co.jp/business/tetsudo/pages/jrc700.htm>

Source: Nippon Sharyo, http://www.n-sharyo.co.jp/index_e.html

Figure 5. 11 THSR 700T Rolling Stock (public domain)

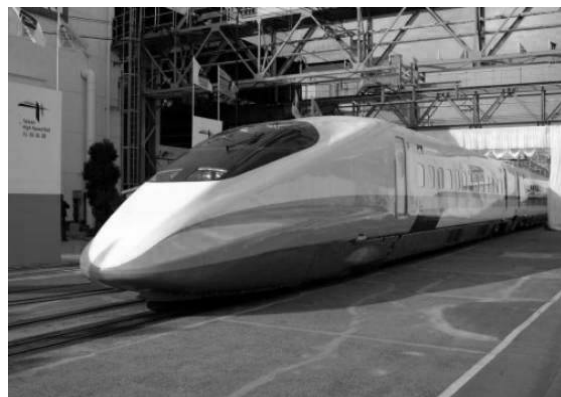

Source: BOHSR:

<http://www.hsr.gov.tw/homepage.nsf/0/76736465c38d88b148256eec00286640>

Although it did not fully adopt the WT-HSR-GP's suggestion of 100 m², the THSRC designed and constructed its tunnels with a size of 90 m².⁴⁴ This size design was still

⁴³ See footnote 31.

⁴⁴ BOHSR, *Memorial Collection for the THSR Open to Traffic*, 22. BOHSR, *Introduction to New Austrian Tunnel Method*, 3.

significantly larger than any of the current Shinkansen lines'. Today's THSR uses the Shinkansen rolling stock 700T which has been known for equipping better technology of fluid design and air tightness. Therefore, the THSR tunnels would be even larger than any of the Shinkansens', TGV's or ICE's in terms of engineering demands. As a result, technically, the THSR might have obtained some advantages from hybridizing the Shinkansen rolling stock and the European tunnel design. However, whether this hybridization was worth it still required taking some other factors into account, such as the factor of construction cost. This might be one of the prices that Taiwan's engineering culture of hybridity pays.

5.2.4 Subcontractor Collaboration

As noted, the THSRC conducted its THSR civil work with internationally subcontracted collaboration. Instead of its original intention, the THSRC seemed to have no choice but to invite several foreign constructors to bring their loans, engineers, technologies and equipment to accomplish the THSR's civil construction. As a senior THSRC engineer responded in an interview, "Taiwan itself could not supply enough resources to build the THSR's aerial structure, tunnels, railroad beds and other civil works in such a short time of five years."⁴⁵ However, if I view this response from another direction, the THSRC might not have been forced but rather had planned to introduce international collaboration in order to complete its civil work as efficiently as possible.

The THSRC divided the whole civil construction project into twelve sections. Most of these sections included the construction of aerial structure, tunnels and usual railroad beds. There were nine different sets of joint ventures that consisted of eleven foreign and six local constructors who shared these sections.⁴⁶ These numbers of subcontractors did not even include

⁴⁵ An interview of SW.

⁴⁶ BOHSR, *Memorial Collection for the THSR Open to Traffic*, 72~3. BOHSR, *Introduction to Other Viaduct Construction Methods: Advancing Shoring Method, Balanced Cantilever Method and Incremental Launching Method* (Taipei: BOHSR, 2006), 118.

other foreign and local cooperative partners that came to be their co-constructors, detail engineering designers, CICE ([Sub]Contractor's Independence Checking Engineer), ISE (Independent Site Engineer) and ICE (Independence Checking Engineer).⁴⁷ Figure 5.1 shows where these detail engineering designers, CICE and ICE were in the process of the THSRC's civil design and review as well as what roles they played. As of the co-constructors, I will discuss them later. In short, these downstream local and foreign subcontractors, joint ventures and their collaborators made a significant and inalienable contribution to the THSRC's civil construction project.

Figure 5. 12 THSR Viaduct Bridge

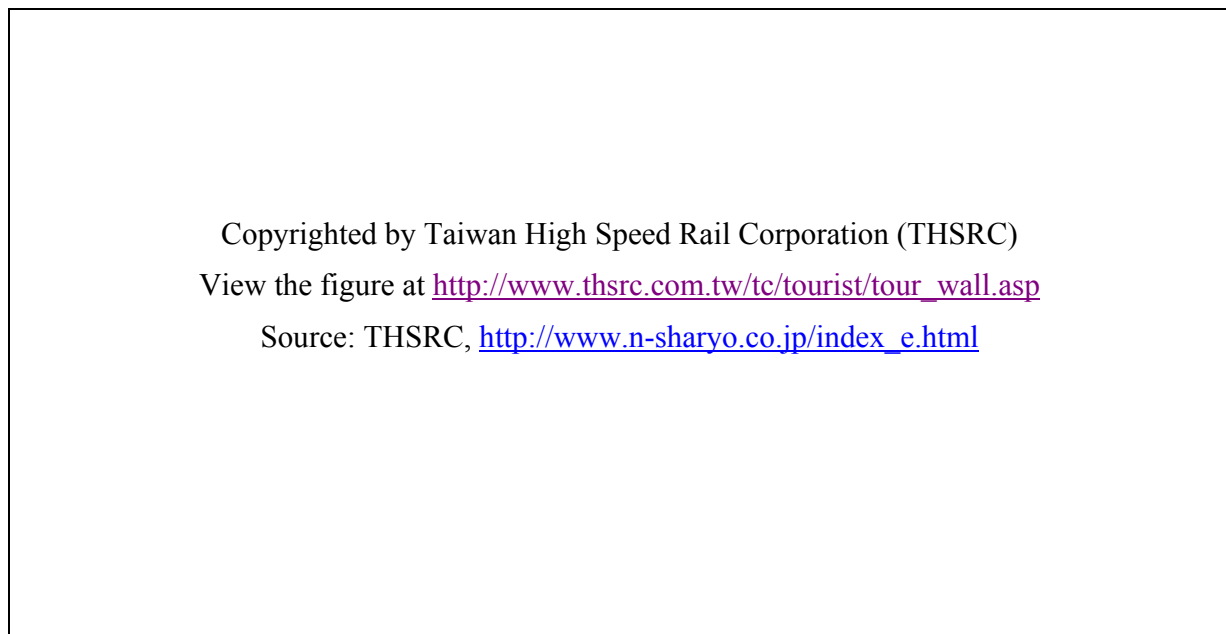

The THSR's aerial structure occupied most of the civil work in the project. This was mainly because the THSR's civil design had attempted to avoid any intersection with all other kinds of transports in order to achieve its high speed and safety since the time when the Institute

⁴⁷ See BOHSR, *Introduction to Full-span Precast & Launching Method*. Also see Song-Tzoo Wu (吳松竹; THSRC Engineer), "Independent Checking, Verification and Validation," in *Proceedings of Rail Engineering Society of Taiwan (RESOT) Annual Meeting 2002* (Taipei: RESOT, 2002), 186~92.

of Transportation and POHSR were in charge.⁴⁸ In addition, it was also believed that an aerial design produce the minimum environmental impact on the passing ground.⁴⁹ Thus, around 72.75% of the THSR railroad, approximately 251 km of its total length of 345 km, was built on the aerial structure. Its continuous bridge all the way from Changhua to Kaohsiung was around 157 km, which was not only a new record in Taiwan but also in the world.⁵⁰ See Figure 5.12.

Figure 5. 13 THSR Viaduct Design (public domain)

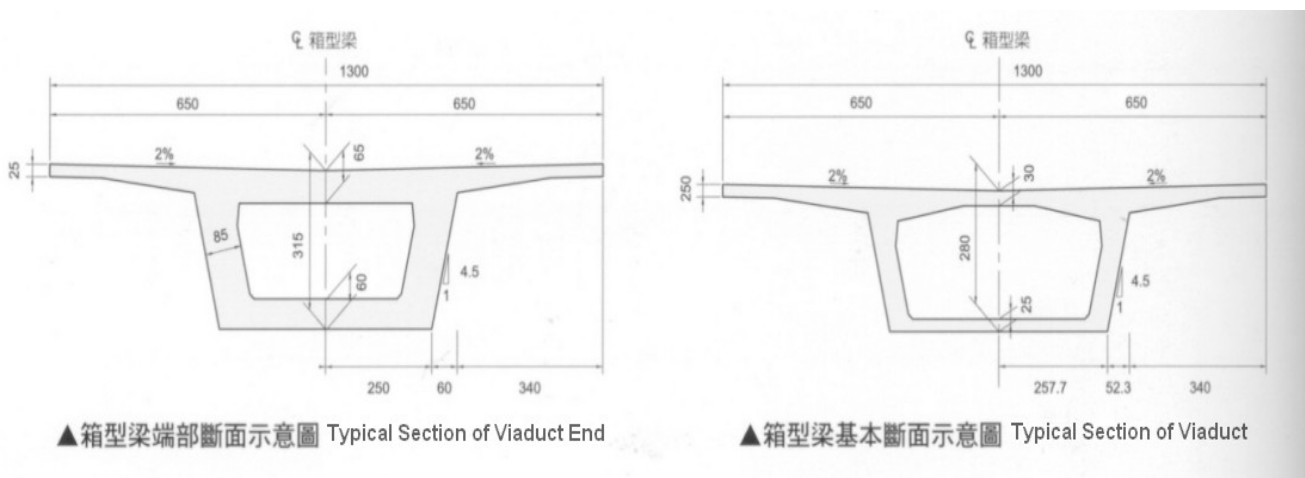

Source: BOHSR, *Introduction to Full-span Precast and Launching Method*, 10.

Around 95% of the THSR aerial structure adopted box girders for their viaducts. Figure 3.4, 3.5 and 3.7 show the WT-HSR-FS and WT-HSR-GP’s general viaduct designs. Figure 5.13 shows the THSR’s general design. Like the other civil designs shown in Table 5.1, the viaduct styles and parameters that today’s THSR adopted were either the same as or close to the WT-HSR-GP’s designs. The THSRC retained most of the viaduct designs and specifications contained in the WT-HSR-GP report. However, the THSRC made some more detailed and additional civil specifications.⁵¹ But, as noted, they were still in a more general fashion, by

⁴⁸ See Institute of Transportation and POHSR, *West Taiwan High Speed Rail General Planning, Final Report*.

⁴⁹ POHSR, “Introduction to West Taiwan Collider HSR Construction Plan,” *Taiwan Railways Journal* 267 (1991): 1~2.

⁵⁰ BOHSR, *Current THSR Construction*, 16~7. BOHSR, *Memorial Collection for the THSR Open to Traffic*, 18.

⁵¹ See BOHSR, *Introduction to Full-span Precast & Launching Method*, 10~7.

which the THSRC's downstream partners could make their own detailed designs and build the THSR's aerial structure using their own different building practices that they were good at.

Figure 5. 14 Round Bridge Beam Pillars (public domain)



Source: BOHSR, *Introduction to Full-span Precast and Launching Method*, 73.

Not all of the twelve sections of the THSR aerial structure thus have a consistent appearance and design. Neither were they built with the same engineering practice. For example, their bridge piers look different: being either square or round. See Figure 5.12 and 5.14. Basically, those nine different joint ventures had their different specialized engineering methods for building their viaduct bridges.⁵² Thus, 54.01% (135.743 km) of the viaduct bridges were built by the full-span precast and launching method, 12.86% (69.359 km) by the advancing shoring method, 3.33 % (8.377 km) by the balanced cantilever method, 0.57% (1.438 km) by the I-shape precast method, and 0.44% (1.11 km) by the incremental launching method.⁵³ These different

⁵² See BOHSR, *Introduction to Full-span Precast & Launching Method*. BOHSR, *Introduction to Other Viaduct Construction Methods: Advancing Shoring Method, Balanced Cantilever Method and Incremental Launching Method*.

⁵³ BOHSR, *Introduction to Other Viaduct Construction Methods: Advancing Shoring Method, Balanced Cantilever Method and Incremental Launching Method*, 10 and 119.

methods were chosen mainly according to different geographical and traffic environments.

Some of those different joint ventures sometimes also applied different launching practices in one method.⁵⁴ For example, four different joint ventures⁵⁵ (responsible for the sessions of C215, C250, C260/270 and C280 respectively) applied three different launching practices to emplace box girders on continuous beam pillars.⁵⁶ See their working processes in Figure 5.15, 5.16 and 5.17. In addition, they also made their concrete box girders' internal pre-stressed structure with different engineering practices (the pre-tensioned or bonded post-tensioned).⁵⁷

⁵⁴ See BOHSR, *Introduction to Full-span Precast & Launching Method*. BOHSR, *Introduction to Other Viaduct Construction Methods: Advancing Shoring Method, Balanced Cantilever Method and Incremental Launching Method*.

⁵⁵ These were (1) the Japanese Obayashi Cooperation/ Taiwanese Fu Tsu Construction (互助營造), (2) the German Hochtief AG/ Dutch Ballast Nedam/ Taiwanese Pan Asia Corporation (泛亞營造), (3) the German Bilfinger+Berger/ Taiwanese Continental Engineering Corporation, and (4) the Korean Samsung/ Taiwanese International Engineering & Construction Group (理成營造)/ Korean Doosan. See BOHSR, *Introduction to Full-span Precast & Launching Method*, especially chapter 6 and 9.

⁵⁶ See BOHSR, *Introduction to Full-span Precast & Launching Method*.

⁵⁷ Pre-stressed concrete is a method for overcoming concrete's natural weakness in tension. It can be used to produce beams, floors or bridges with a longer span than is practical with ordinary reinforced concrete. Pre-stressing tendons (generally of high tensile steel cable or rods) are used to provide a clamping load which produces a compressive stress that offsets the tensile stress that the concrete compression member would otherwise experience due to a bending load. Traditional reinforced concrete is based on the use of steel reinforcement bars, rebars, inside poured concrete. See Edward G. Nawy, *Prestressed Concrete: A Fundamental Approach* (Englewood Cliffs, NJ: Prentice Hall, 1989).

Figure 5. 15 Launching Trolley
(public domain)

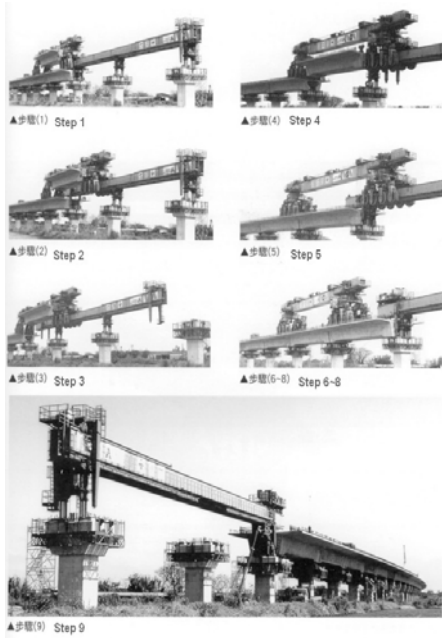

Figure 5. 16 Launching Gantry 1
(public domain)

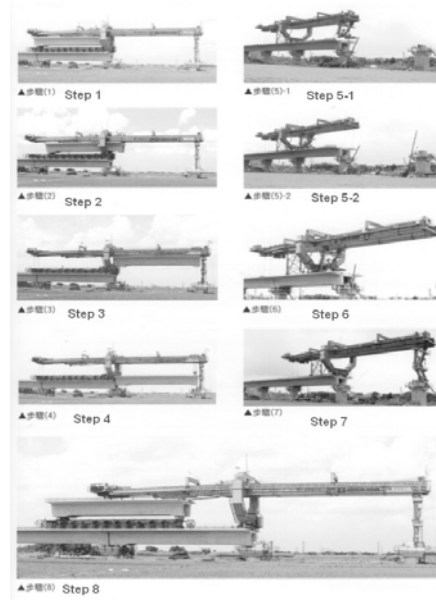

Figure 5. 17 Launching Gantry 2
(public domain)

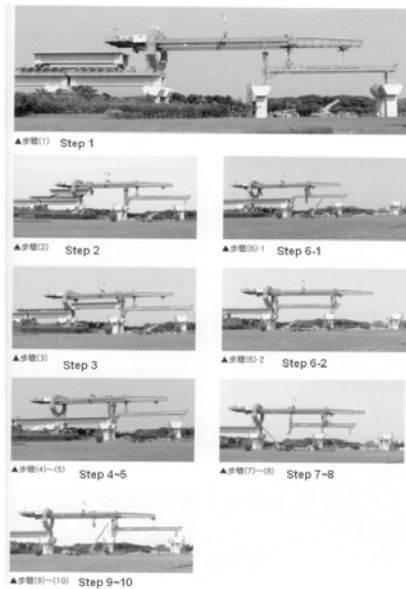
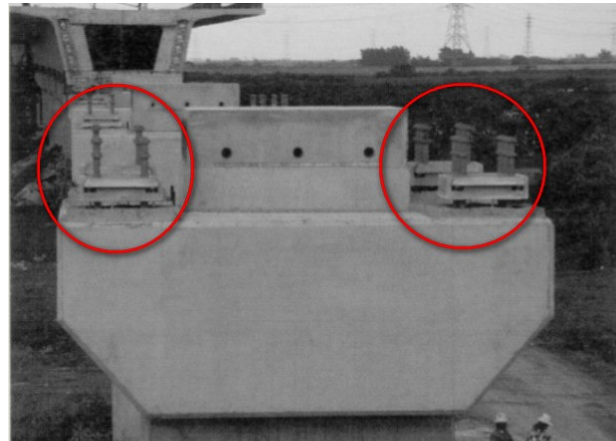

Figure 5. 18 Viaduct Shear Bearing
(public domain)



Source: BOHSR, *Introduction to Full-span Precast and Launching Method*, 51, 53, 55 and 144.

5.3 Impacts of International Collaboration on Taiwan's Engineering Culture of Hybridity

The international collaboration in the THSR civil construction showed some different phases over time. While the foreign HSR civil engineers dominated the major engineering job during the beginning period, the Taiwanese civil engineers gradually took over after a few years. For example, the German civil engineers played the most important role in the first year of the C250 project.⁵⁸ Although they were primarily responsible for such secondary jobs as the interfacial coordination in the first year, the Taiwanese civil engineers were able to substantially participate in the project in the third year.⁵⁹ They earned some of the German engineers' respects with their local engineering abilities and experiences. Generally, localness has been one of the most important dimensions that characterize civil engineering. Civil engineering work needs intense understanding of and coordination with the local geographic and geological environment.⁶⁰ For instance, the German engineers used alumina cement to lock out underground water when they made the pile foundation for the HSR viaduct piers on the bed of the Dajia River (大甲溪). Unfortunately, they failed several times and this caused some of their machines to break down. The sudden spurt of huge amounts of underground water basically prevented the German engineers from making the proper pile foundation. The local Taiwanese civil engineers learned about this before, because it was common to encounter this problem in most of Taiwan's geological environments. They thus suggested applying their conventional method of drainage to deal with the problem. The German engineers finally accepted their suggestion and solved the problem. However, this local suggestion was not adopted until after they had failed several times and had obtained no other feasible suggestions from those Taiwanese engineers who had been trained abroad.⁶¹

⁵⁸ The C 250 project's JV was consisted of the German Hochtief, Dutch Ballast Nedam and Taiwanese Pan Asia Corporation. It was completed in three years.

⁵⁹ An interview with JL.

⁶⁰ An interview with RL.

⁶¹ An interview with JL.

One of the THSRC's intentions with distributing twelve minor civil projects to different sets of foreign/Taiwanese joint ventures⁶² was to develop local constructors' engineering abilities.⁶³ By working with the Germans, the local Taiwanese engineers learned some civil engineering techniques and practices from them. For example, the Taiwanese civil engineers were capable of building pre-stressed bridges with a span of over 40-meters after their cooperation with the Germans in the THSR project. They soon picked up new engineering techniques and applied them to the National Expressway No. 5 and 6 projects.⁶⁴ A THSRC civil engineer who shared this example indicated that "the Taiwanese civil engineers have been good at learning, hybridizing and practicing engineering techniques from the Germans."⁶⁵

In addition, the Taiwanese civil engineers noticed some different practices between the German and Japanese HSR civil engineering in the THSR project. For example, a senior THSRC engineer revealed that the German and Japanese Joint ventures had different practices of designing the position of pre-stressed bearing protrusions between bridge piers and box girders. See Figure 5.18 Viaduct Shear Bearing. The Germans calculated the shear strength caused by the HSR rolling stock on the viaduct, and then designed how long to pull those protrusions up. However, the Japanese designed their positions by repeating numerous tests until they found the satisfied point. Their tests could bring and develop them a-theoretical engineering experiences over time. The Japanese civil engineers thus might emphasize experiential mentorship and

⁶² Eleven of the twelve sections in the THSR civil construction project were built by nine different sets of joint ventures, in which there were six Taiwanese constructors joining. See BOHSR, *Introduction to Other Viaduct Construction Methods: Advancing Shoring Method, Balanced Cantilever Method and Incremental Launching Method*, 119.

⁶³ Interviews with RW, Fu-Hsiang Wu and RL.

⁶⁴ The Hsueshan Tunnel is a part of the National Expressway No. 5 project. It is the fifth longest road tunnel in the world. It took the Taiwanese government fourteen years to complete in 2006. Other than the tunnel, National Expressway No. 5 also included some important engineering revolutions in bridge building in Taiwan. It was the first expressway to apply the pre-stressed method, like THSR, to build highway bridges. See Kuo-Long Chen (陳國隆), "Evolution of National Expressway Bridge Engineering Techniques," in *Proceedings of the 12th Taiwan Area National Expressway Engineering Bureau Conference* (Taipei: MOTC, 2002).

<http://gip.taneeb.gov.tw/ct.asp?xItem=11724&CtNode=2798> See more about the Expressway No. 5 and 6 at <http://gip.taneeb.gov.tw>

⁶⁵ An interview with JL.

accumulation than engineering calculation and simulation when doing civil designs and practices.⁶⁶

While they gained experience working with foreign engineers, the Taiwanese civil engineers reflexively looked at how they practiced engineering in the THSR and other previous projects. A THSRC engineer stated that “the Taiwanese engineers have been inclined to depend on their experiences more than machinery, but foreign engineers seemed to be just the opposite. Our experiential inclination might have been influenced by the mentoring tradition from the Japanese engineering legacy.”⁶⁷ He further indicated that some of the local Taiwanese engineers thus might not have gotten along well with the western engineers during their early THSR cooperation period. Not only did the western engineers might look down upon the Taiwanese engineers, but also they brought in different engineering philosophies that differed from local thinking. Some of the Taiwanese engineers were even intentionally not allowed to assist western engineers until they made mistakes or even failed to complete their jobs.⁶⁸

However, while more and more Taiwanese engineers have been trained in the West, especially in the U.S., more and more senior local engineers fade away or are forced to rely more on Taiwanese engineers trained abroad. The population of Taiwanese engineers with foreign degrees has grown and even composes the leading group of Taiwanese engineering.⁶⁹ They have been eager to learn and bring western engineering into Taiwan. Although some tension existed between the local and foreign engineers in the C250 project as noted, those local Taiwanese engineers soon followed their colleagues trained abroad to learn and adopt foreign engineering methods and techniques. They understood that some of their engineering capability was still inferior to the West and Japan.⁷⁰ In addition, some of the Taiwanese engineers trained abroad

⁶⁶ *Ibid.*

⁶⁷ *Ibid.*

⁶⁸ Interview with RL and RY.

⁶⁹ An interview with Bol-Yi Tsuei.

⁷⁰ An interview with RY.

also used some strategies, such as their bilingual ability, to earn local engineers' trust. They sometimes even attempted to manipulate those local engineers by stating their professional opinions with foreign engineers' support or endorsement (假傳聖旨).⁷¹

One thing worth noting was that foreign engineering methods and techniques have never had a unanimous origin. It has been known that most of the Taiwanese engineers with experience abroad have been trained in the U.S. The U.S. aid program was one of the key factors that contributed to this trend since the 1950s.⁷² However, the government of the Republic of China on Taiwan was also aware that this inclination might not be good for Taiwan's development at the time. Therefore, it encouraged a certain number of students to acquire further engineering and other professional education in Europe or Japan⁷³. Bol-Yi Tsuei, the CECI vice president as well as the chief THSR engineering investigator for the BOHSR, claims that Taiwanese engineering has seemed to be like a "testing hybrid" since different Taiwanese engineers with different abroad training backgrounds have constantly brought their different engineering practices into Taiwan.⁷⁴

In short, the THSR's civil design and construction displayed an engineering tradition of international and hybrid collaborations. The Taiwanese civil THSR engineers learned some experiences and techniques from their international engineering cooperation. In addition, the local THSR manufactures or companies also acquired some engineering transfer concerning civil methods and practices from their foreign joint partners. However, unlike Taiwan Railways' locomotive acquisition and Electrification projects subject to the U.S. and Japan as noted in chapter two, the Taiwanese civil engineers in the THSR project has exploited international

⁷¹ An interview with RL.

⁷² See Su-Fen Liu (劉素芬) ed., *K.T. Li: My Taiwan Experience—K.T. Li on Taiwan's Financial and Economic Policy Making and Thinking* (Taipei: Yuanliu Publications, 2005), 482~4. Also see Mutual Security, "U.S. Technological Aid Program," *Industry of Free China* 5: 2 (1956): 21~3.

⁷³ *Ibid.*

⁷⁴ An interview with Tsuei.

collaboration in order to bring the THSRC and Taiwan's engineering development the most benefits, but they also had to pay some price.

CHAPTER 6

EVOLVED TAIWANESE ENGINEERING HYBRIDITY: OPTIMIZATION, MEDIATION AND NON-DEPENDENCE

However, due to cultural, let alone linguistic, differences between Japan and Taiwan...The Japanese are already beginning to emphasize that the THSR is not a Shinkansen and are gradually distancing themselves from responsibility for the [THSR] project.¹—

Hood

Unlike the THSR's civil construction, the THSRC inherited and adopted few engineering specifications and designs from the BOHSR for its track and core electrical-mechanical systems. This was mainly because, as noted, the BOHSR placed more emphasis on making civil designs than the other systems before the THSR became a BOT project. It also made fewer studies of the HSR core and track systems. In addition, the BOHSR wanted to give the THSRC as much engineering flexibility as possible in order to make the BOT model work. The THSRC was given generous room to plan the THSR's track and core systems. Moreover, these systems' technologies became more advanced in the 1990s and early 2000s. The THSRC extended the engineering thinking from engineering inclusiveness to optimization. However, the notion of optimization had deviated from the POHSR's early ideal attempt to build the best HSR in the world. The THSRC intended to pursue localized system performance by taking advantage of hybridizing different engineering designs and practices. Instead of competing with other HSRs, the THSR was proposed to be compatible with the Taiwanese engineers' local engineering considerations.

¹ Hood, 205.

The THSRC placed significant emphasis to maintain its independence from the Japanese or other foreign engineers regarding the track and core systems. However, the THSRC encountered more fundamental conflicts and struggles over these systems than it did with its civil construction work in terms of engineering thinking. In other words, they were mainly caused by differences in engineering thinking among the Japanese, European and Taiwanese engineers. Indeed, the THSRC lacked the ability to make a HSR core system and needed to import one from outside of Taiwan. But the THSRC still used strategies to gain itself some engineering independence. It certainly paid a price for this, such as over and redundant designs. In addition, this hybridization also created some critics of the Taiwanese HSR engineers because they seemed to be more like engineering butchers rather than hybridizers. Similar with the notion of cannibalization discussed in chapter three, they knew what piece of meat/parts they needed to change or repair but learned little about how to produce it. Nevertheless, engineering butchers and hybridizers were not two different species in Taiwan's engineering history. The former evolved into the latter after a certain amount of time.

6.1 Optimization: Mixing Different Track Designs

The THSRC's decision to replace the European core system with the Shinkansen system required the THSR track system to fit with some of the Japanese designs and standards, but this policy did not determine all of its track system designs. Actually, neither did the Shinkansen core system determine everything in the four other major projects that consisted of civil, track, station and depot systems. The THSRC intended each of its five major systems to have their own engineering considerations and specifications.

The current THSR track system contains both European and Japanese designs. After it broke ground on the civil work in March 2000, the THSRC decided to adopt the Shinkansen core system in December of the same year. Then, the THSRC subcontracted out all five minor track

projects in 2002. Therefore, unlike most of its civil work which was based on the WT-HSR-GP report, the THSRC changed some track specifications in the report in order to make its track system compatible with the Shinkansen rolling stock and other core subsystems. However, the THSRC also incorporated some of the latest European track turnouts and rail beds in order for them to be compatible with some of the THSR's civil and linear designs.

The current THSR track system thus is very different from the designs in either the WT-HSR-GP report or other Shinkansen lines. The THSRC's strategies of general specification making and project partitioning invited the different track designs and the latest track designs into the THSR. For example, while it used the Japanese JIS-60² rail and non-ballast slab rail bed (J-Slab), the THSR track system also installed the German fast turnouts, Rheda 2000 (Rheda) and Chunnel Low Vibration Track (Low Vibration) rail beds in some sections. Today's THSR track system could be characterized as a Taiwanese product with different foreign components. The THSRC collected and integrated these different track designs rather than simply following the Japanese or other foreign track technologies.

6.1.1 Hybrid Specification Making

In general, the current THSR track system showed the European design more than the Japanese. Like its civil construction, the THSRC also inherited some engineering specifications from the WT-HSR-GP report that contained more of the European designs. The THSRC adopted the same designs, consisting of the HSR rail gauge of 1,435 mm, rail weight of 60 kg/m and the continuously welded rail as was contained in the WT-HSR-GP report. However, they were more like the general HSR specifications, since the Shinkansen, TGV and ICE all applied the same parameters and designs. In other words, the THSRC would still use these designs even if these suggestions were not in the WT-HSR-GP report. Other than these, nevertheless, the

² The JIS is an abbreviation of Japanese industrial standards. The 60 refers to the rail that was manufactured with the standard of 60 kg per meter. See Japanese Industrial Standards Committee, <http://www.jisc.go.jp/eng/index.html>

other specifications that the WT-HSR-GP suggested were more similar to the TGV and ICE designs than the Shinkansen. These designs included a larger scale of turnouts, a wider distance between track centers, and the ballast track with the pre-stressed concrete sleepers and these sleepers' placement design.³ See some of these engineering specifications in Table 6.1

Table 6. 1 Track and Rolling Stock Engineering Specifications of WT-HSR-FS, WT-HSR-GP, and Shinkansen, TGV and ICE before 1991, and THSR in 2007 (public domain and used under fair use guidelines)

HSRs Specifications	Shinkansen			WT-HSR-FS (Mar. 1990)	WT-HSR-GP (Oct. 1991)	TGV (Southeast 1981) (Atlantic 1989)	ICE (Mannheim —Stuttgart) (1991)	THSR (Jan. 2007)
	Tōkaidō (1964)	Sanyō (1972)	Tōhoku /Jōetsu (1982)					
Rail Gauge (mm)	1,435	1,435	1,435	1,435	1,435	1,435	1,435	1,435
Rail Weight (kg/m)	60 (50 before 1980)		60 (JIS)		60 (UIC)	60 (UIC)	60 (UIC)	60 (JIS)
Length of Continuously Welded Rail (m)	1,500				396	288~396		900~1,200
Distance between Track Centers (m)	4.2	4.3	4.3	4.4	4.4	4.2/4.5	4.7 (4.5)	4.5
Rail Bed Style (numbers/km)		68% Concrete Slab Track	95% Concrete Slab Track		Pre-stressed Concrete (PC); 1,666	Twin PC; 1,666	PC	J-Slab 86.6% Rheda 8.5% Low Vibration 3.8% PC 1.0% Embedded 0.1%
Rolling Stock Power Style	EMU (10M [Motor Trains]+6 T [Trailed Trains])		EMU (12M)		EMU/PP	PP	PP	EMU (12M+4T)
Rolling Stock Train Car Design Length/ Width/ Height (m)	25/3.38/4		25/3.385/4		NA/3.1/NA	18.7/2.814/3.42 18.7/2.90/3.48	NA/3.02/NA	25/3.38/3.65
Rolling Stock Length (m)	402.1		303.3		330	237.59	357.92	304

³ POHSR, *West Taiwan High Speed Rail General Planning, Final Report*, 5-30~7.

HSRs Specifications	Shinkansen			WT-HSR-FS (Mar. 1990)	WT-HSR-GP (Oct. 1991)	TGV (Southeast 1981) (Atlantic 1989)	ICE (Mannheim —Stuttgart) (1991)	THSR (Jan. 2007)
	Tōkaidō (1964)	Sanyō (1972)	Tōhoku /Jōetsu (1982)					
Rolling Stock Capacity (person)	1,323		833		800 (±5%)	485	669	989
Signaling System	Uni-directional				Bi-directional	Bi-directional	Bi-directional	Bi-directional
Max. Static Acceleration (km/hr/second)	1.6	1.6	1.6				1.62	2.0

Sources: See Table 5.1

As noted, the THSR followed most of the European linear and civil designs in the WT-HSR-GP report. Its track design should be linearly straighter and vertically smoother than the Shinkansen's. The THSR track turnouts thus were generally designed with a larger scale in terms of a longer radius distance⁴ and were manufactured using special techniques. They were called fast turnouts since they allowed the HSR rolling stock to pass through at a relatively higher speed. The THSRC installed the German BWG fast turnouts for the THSR.⁵ As a result, the THSR's Shinkansen trains could run faster on its turnout sections than the Shinkansen ones in Japan. In addition, the THSR also chose to have a wider distance between track centers, by which the THSR passengers would feel less instant vibration and tinnitus than the Shinkansen passengers when two trains meet from opposite directions. These designs showed that the THSR track system involved some of the European HSR considerations.

The THSRC's decision to adopt the Shinkansen core system certainly brought some Japanese detail designs for the THSR's track system. "The interfacial friction between the wheel and rail shall be as small as possible."⁶ Since it was going to import the Shinkansen rolling stock at the time, the THSRC made the JIS-60 with a 1:40 leaning angle rather than the UIC-60 as the

⁴ BOHSR, *Introduction to HSR Track Engineering and Construction* (Taipei: BOHSR, 2006), 106~14.

⁵ *Ibid.*

⁶ An interview with VY.

THSR rail model in its Employer’s Requirement.⁷ While the UIC-60 was a more common rail model that was applied internationally to either the HSR or conventional railways, such as the TGV and ICE, the JIS-60 was only installed in Japan. Although they had the same rail weight design of 60 kg/m, the UIC-60 and JIS-60 had different sizes, cross section designs and metal ingredients.⁸ See their typical section designs in Figure 6.1 and 6.2. Generally, the JIS-60 rail is slightly larger than the UIC-60 in terms of height and width, but its rail head height is shorter than the other. It is worth noting that the THSRC later allowed one of its track subcontractors to manufacture some of the JIS-60 rail in Germany.⁹

Figure 6. 1 JIS-60 Typical Section
(public domain)

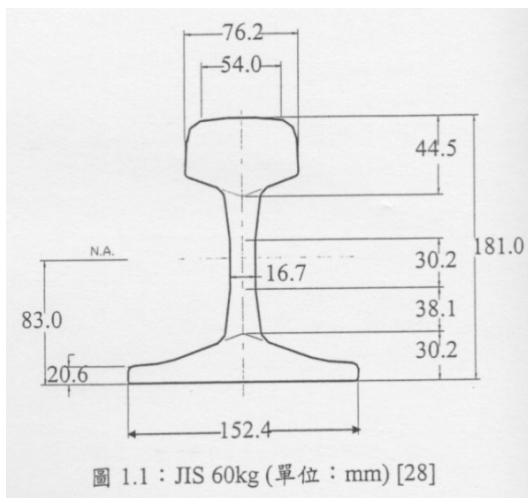
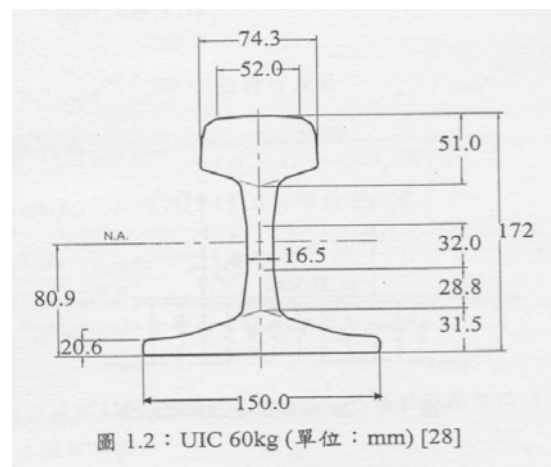

Figure 6. 2 UIC-60 Typical Section
(public domain)



Source: Yung-Hsiang Chen *et al*, 1-3~4.

6.1.2 Pursuing Efficiency by Installing Different Types of Rail Beds

⁷ THSRC, “Engineering Specifications of the THSR Track System,” in BOHSR *Introduction to HSR Track Engineering and Construction*. “UIC” refers to the International Union of Railways (Union Internationale des Chemins de Fer). See International Union of Railways http://uic.asso.fr/spip.php?id_article=757&page=home

⁸ See Chien ed.

⁹ An interview with VY. See *United Daily*, “THSRC Taipei to Banciao Construction Behind,” Aug. 23, 2003.

The THSR adopted five different designs of rail beds, in which four of them were non-ballast rail beds and the other was the ballast rail bed with the pre-stressed concrete sleepers. The non-ballast rail beds occupied 99% of the total length of the THSR track, including the J-Slab 86.6%, Rheda 8.5%, Low Vibration 3.8% and the embedded rail bed 0.1%. See Figure 6.3 to 6.10. Only 1% ballast rail bed was arranged in some depot areas and at the end section of the main track in Kaohsiung.¹⁰

Figure 6. 3 J-Slab Rail Bed (public domain)



Figure 6. 4 J-Slab Structure (public domain)

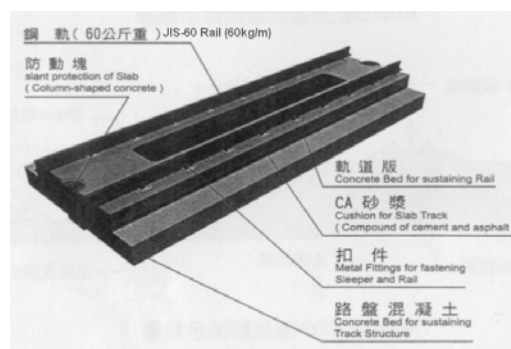

Source: BOHSR, *Introduction to HSR Track Engineering and Construction*, 68

Source: BOHSR, *Introduction to HSR Track Engineering and Construction*, 33.

The WT-HSR-GP report mentioned that the French SOFRERAIL consultants suggested in 1990 that the Taiwan HSR adopt the ballast track with pre-stressed concrete sleepers.¹¹ At the time, while both the TGV and ICE still used ballast track with PC sleepers, the Shinkansen had used paved concrete slab beds (J-Slab) since 1972.¹² The concrete slab track was recognized as a more advanced technology than the conventional ballast track in terms of safety and economic

¹⁰ BOHSR, *Introduction to HSR Track Engineering and Construction*, 30.

¹¹ POHSR, *West Taiwan High Speed Rail General Planning, Final Report*, 5-33~7.

¹² Railway Reconstruction, *Visiting Report on the Japanese Shinkansen: Planning, Design, Build and Operation*, 29. POHSR, *Visiting Report on the German and French HSRs*, 10, 14~5. Also see Chien ed.

efficiency.¹³ Although they hoped to take advantage of the latest technologies from the Shinkansen, TGV and ICE as much as possible, the POHSR engineers wanted technologies that had already had business experience for years. Because the planned Taiwan HSR intended to reach its maximum business speed of up to 300 km/hr, the SOFRERAIL suggested the POHSR follow the TGV ballast track design. The TGV was the only HSR system whose business speed reached 300 km/hr at the time. The maximum speed the J-Slab rail bed endured was only 275 km/hr in the early 1990s. Since the J-Slab had no business experience with its rolling stock running up to 300 km/hr, the POHSR endorsed the SOFRERAIL's suggestion of adopting the rail bed made of the pre-stressed concrete sleepers.¹⁴

Figure 6. 5 Rheda 2000 Rail Bed
(public domain)



Source: BOHSR, *Introduction to HSR Track Engineering and Construction*, 89

Figure 6. 6 Rheda 2000 Structure

Copyrighted by RAIL.ONE

View the figure at

http://www.railone.com/fileadmin/dateien/03_Broschueren/EN/rheda_2000_en.pdf

Source: *RHEDA 2000: the Ballastless Track with Concrete Supporting Layer*, 8.

Although it kept the WT-HSR-GP report's maximum design speed of 350 km/hr, the THSRC only required the THSR's non-ballast and ballast track designs that had five-years of

¹³ Ballastless tracks have been known of saving much more money and manpower for maintenance than traditional ballast tracks. In addition, the HSR rolling stock might be jeopardized from some rocks blown by itself while running on the ballast track. Also see Chien ed.

¹⁴ POHSR, *West Taiwan High Speed Rail General Planning, Final Report*, 5-33~7.

practical experience with maximum business speeds of 250 km/hr and 160 km/hr respectively at least over a distance of 10 km.¹⁵ In other words, the THSRC was not as strict as the POHSR. The THSRC's design and review process for the THSR's track project was similar with its civil work.¹⁶ See Figure 5.1. The THSRC also wanted Taiwanese/foreign joint ventures to come to bid on their five minor track projects, in which the design and building jobs were combined. These joint ventures, like those in the construction project, needed their independent checking engineer's approvals before they submitted their proposals to the THSRC.¹⁷ In the end, the United Taiwan Track Joint Venture (台灣軌道合夥)¹⁸ earned one minor project and the Taiwan Shinkansen Trackwork Joint Venture (台灣新幹線軌道工事共同企業體)¹⁹ won the other four. While the latter consisted of partners from Japan and Taiwan, the former included Australian, German and Taiwanese manufacturers and constructors.²⁰

After it reviewed its subcontractors' proposals, the THSRC chose to apply the non-ballast tracks to most of the THSR railroad. The J-Slab was the main track style, the Rheda was used in the sections with stations and turnouts, the Low Vibration was used in the section containing the Taipei Tunnel, and the embedded track was used in the Taipei Station.²¹ Basically, the non-ballast tracks' construction cost 1.3 times more than the conventional ballast tracks, but they could save more money in the long run. This was mainly because the non-ballast tracks needed much less money and manpower for maintenance than the ballast tracks.²² The THSRC

¹⁵ BOHSR, *Introduction to HSR Track Engineering and Construction*, 20~1.

¹⁶ *Ibid.*, 26~7.

¹⁷ *Ibid.*

¹⁸ This joint venture consisted of Australia Barclay Mowlem Construction Limited, and four Hong Kong, German and Taiwanese companies. See *THSRC 2008 Annual Financial Report*, download at Taiwan Market Observation Post System, http://emops.twse.com.tw/emops_all.htm

¹⁹ This joint venture consisted of Japanese Mitsubishi Heavy Industries and eighteen Japanese and Taiwanese companies. See *Liberty Times*, "Fail to Vibration Test, the Taiwanese/Japan Track JV Not Allowed to Install Tracks Yet," Aug. 27, 2003.

²⁰ See *Ibid.* Also see *Liberty Times* on Aug. 27, 2003.

²¹ BOHSR, *Introduction to HSR Track Engineering and Construction*, 30.

²² "Compared with conventional ballasted track, the quantity [of the Shinkansen J-Slab maintenance work] is one fifth...As the [J-Slab] construction cost is approximately 1.3 times that of ballasted track, it appears that the slab track has an economic advantage in the range of just a decade or so counting the enormous reduction of maintenance

calculated that their adoption of non-ballast tracks might be able to cover the extra construction cost in comparison with conventional tracks in ten years.²³

Figure 6. 7 Low Vibration Rail Bed
(public domain)

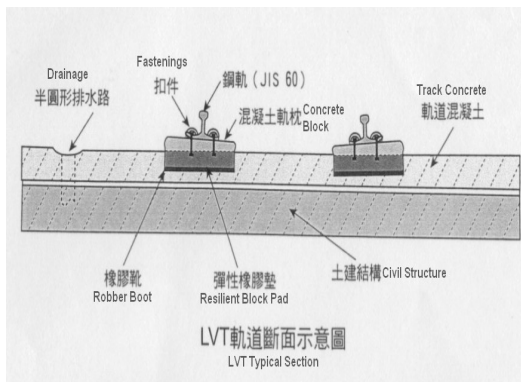

Figure 6. 8 Low Vibration Structure

Copyrighted by Sonneville International Corporation.

View the figure at <http://www.sonneville.com>

Source: Sonneville International Corporation, <http://www.sonneville.com/low-vibration-track-lvt/>

Source: BOHSR, *Introduction to HSR Track Engineering and Construction*, 36

Although they were all non-ballast tracks, the J-Slab, Rheda and Low Vibration had different advantages and costs. Each of them also had its history and specifications in their different countries of origin. There were some other non-ballast track designs, such as the British Stedef VSB, that had some other different characteristics as well.²⁴ In short, non-ballast tracks were more like a localized product. These different non-ballast tracks were rarely being put together on the same railroad. The J-Slab, Rheda and Low Vibration evolved over time in

cost...”. Takaharu Nagafuji (長藤敬晴), “Relative Merits of Ballast and Slab Track: Track Technology for High Speed Railways,” in *Proceedings of Workshop for High Speed Railways in Taiwan* (Taipei: BOHSR, 1997), 4-2.

²³ An interview with VY.

²⁴ Yung-Hsiang Chen *et al*, V.

their countries of origin, but they had not been arranged together on the same railroad until the THSR.²⁵ The THSRC attempted to use the advantages of each of them.

The reasons that the THSRC adopted the J-Slab design for most of its track were (1) the similarity of the natural environment between Taiwan and Japan, (2) using the non-ballast track was the main trend in the world, (3) the J-Slab had already had forty-year experience, (4) the J-Slab was able to save 95% of the expense of maintenance, (5) it was easier to attain consistent quality and faster to conduct installation since those slabs were pre-cast.²⁶ The THSRC addressed the importance of localness and the J-Slab's advantages in comparison with the ballast and other non-ballast tracks. Nevertheless, while it showed its preference to adopt the J-Slab, the THSRC also noticed the advantages of other non-ballast tracks. Some designs from other track systems could help the THSR's performance in terms of efficiency.

Figure 6. 9 Embedded Rail Structure
(public domain)



Figure 6. 10 THSR Ballast Rail Bed
(public domain)

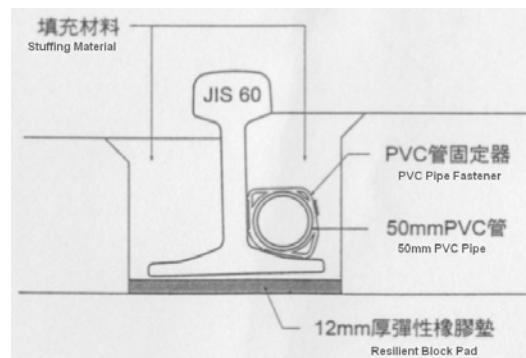

Source: BOHSR, *Introduction to HSR Track Engineering and Construction*, 36

Source: BOHSR, *Introduction to HSR Track Engineering and Construction*, 105.

²⁵ See Yung-Hsiang Chen *et al.* Qih-Chang Wang (王其昌) and Qih-Meng Han (韓啓孟) ed. and trans., *Slab Track Design and Build* (Chengdu, Sichuan: Southwest Jiaotong University, 2002). Also see Chien ed.

²⁶ BOHSR, *Introduction to HSR Track Engineering and Construction*, 33.

The Germans installed most of the non-ballast Rheda track on their railways after 1991.²⁷ The ICE line from Köln to Frankfurt, open to traffic in 2002, applied the Rheda to most of its track, and it allowed its rolling stock to run at a speed of 300 km/hr.²⁸ However, the Rheda showed less competitiveness than the J-Slab with some of the above THSRC's considerations. In addition, the Rheda cost more than the J-Slab.²⁹ Nevertheless, the THSRC still applied the Rheda in the THSR's turnout sections because it could facilitate its rolling stock's performance. Briefly, as noted, the THSRC accepted the WT-HSR-GP's suggestion of installing fast turnouts that would allow the rolling stock to leave and approach at speeds up to 130~160 km/hr.³⁰ According to Yung-Hsiang Chen *et al*'s research, commissioned by the BOHSR, the Rheda track possessed a higher rigidity than the J-Slab, by which the HSR rolling stock would be allowed to approach and leave the stations with a higher speed. In addition, it could alleviate more instant shear force than the J-Slab when the rolling stock approached the stations.³¹ The THSR passengers thus might be more comfortable.³² Even though it cost more than the J-Slab, the THSRC decided to install the Rheda track in the turnout sections, including the whole station sections where they placed most of the fast turnouts.

In order to reduce the rolling stock's vibration and noise, the THSRC applied the Low Vibration track in the Taipei Tunnel that passes under the Taipei metropolitan area. The Low Vibration track, which was installed in the Chunnel and Hong Kong subway as well, was believed to offer better track resilience than the others, by which the THSR rolling stock might

²⁷ See Chien ed., 516~9. Also See RAIL.ONE <http://www.railone.com/en/main-nav/products/railways-and-commuter-traffic/ballastless-track-systems.html>

²⁸ The ICE from Köln to Frankfurt began construction in 1995. It installed 158 km of the total length of 219 km with the Rheda track. Chien ed., 494, 516~18. BOHSR, *Introduction to HSR Track Engineering and Construction*, 34.

²⁹ An interview with Fu-Hsiang Wu.

³⁰ POHSR, *West Taiwan High Speed Rail General Planning, Final Report*, 5-33. BOHSR, *Introduction to HSR Track Engineering and Construction*, 34.

³¹ Yung-Hsiang Chen *et al*, 3-63, 6-5.

³² BOHSR, *Introduction to HSR Track Engineering and Construction*, 34.

cause less vibration to the neighborhoods lying along the tunnel.³³ In addition, the THSRC also used the embedded track in the Taipei Station because the height of the platforms was too short to fit the THSR rolling stock. These platforms used to be Taiwan Railways' platforms but they handed them over to the THSRC in 2004.³⁴ The embedded track would allow the THSR rolling stock to fit Taiwan Railways' platforms.³⁵ Finally, the THSRC paved some ballast tracks mainly in the depot areas. Some advantages of the ballast track are that it was easier to adjust its routes and to integrate it with other maintenance facilities than the non-ballast tracks.³⁶

Eventually, the THSR adopted four different non-ballast tracks and built a short section of traditional ballast track on its railroad. These different rail beds were installed with the Japanese JIS-60 rail and paved on the railroad with the European linear design. The THSRC was like an engineering project manager who selected and installed the latest tracks and specifications whose designs might level up the THSR's performance. The THSRC was also concerned if the THSR could be run sustainably and independently in Taiwan, so every joint-venture was required to include a local partner to participate in each of the minor track projects.

However, in general, some of the Taiwanese THSRC engineers questioned this hybrid and joint-venture policies might be unable to upgrade Taiwan's railway technology and other relevant industries. This was mainly because Taiwan's market was too small. Moreover, they complained that the foreign engineers and consultants had too much control over the THSRC. The Taiwanese engineers could not acquire some of the critical technologies through this THSR project.³⁷ Nevertheless, those Taiwanese engineers might also have overlooked their

³³ *Ibid*, 35.

³⁴ See *Chinatimes*, "MOTC Solutions to the Taipei Platform Conflict between the Taiwan Railways and THSRC," Feb. 27, 2003.

³⁵ BOHSR, *Introduction to HSR Track Engineering and Construction*, 36.

³⁶ *Ibid*, 37.

³⁷ Interviews with the THSRC engineers.

contributions in integrating the different systems, maintaining the THSR, and gradually enabling its independence from foreigners on their land.

6.2 Managing for Mediation

We did the civil construction first and then decided to adopt the Japanese system. The current THSR's core system, including its rolling stock and electrical-mechanical equipment and systems, is totally the Japanese system. The THSR is no such thing of a hybrid system.—Nita Ing (殷琪)³⁸

The Japanese engineers have been better at developing their engineering profession from practices and experiences than theories. They were reluctant to allow their Shinkansen rolling stock to run on the European linear track in the beginning. They wanted to make the THSRC convert its civil construction into the Japanese style. The Japanese claimed that their experience has earned their Shinkansen absolute safety and a perfect record for more than three decades.—Ching-Lung Liao³⁹

The THSR could be viewed as another Shinkansen if focusing on its core system manufacturing. However, the THSR could also be understood as a hybrid product with Japanese and European designs if taking it as an intact HSR system. Actually, the THSR reported that it contained twenty-six differences in terms of core system designs from the Shinkansen.⁴⁰ The THSRC asked the Japanese HSR engineers to change these designs primarily on the basis of its

³⁸ See Wan-Yu Wu (吳琬瑜) and Tsao-Yi Wu (吳昭怡), “Nita Ing: the THSR should be De-Ingimized,” *Common Wealth* 368 (2007): 55~9. Nita Ing was the chairman of the THSRC since its establishment in 1998 until Sep. 22, 2009.

³⁹ An interview with Ching-Lung Liao

⁴⁰ See Hiroyoshi Tanaka (田中昌宏), “THSR's Current Situation and Issues (台灣高速鉄道プロジェクトの現況),” *Journal of Japan's Railway Engineers' Association* 47: 10 (2004).

foreign consultants' opinions, especially those from France and Germany.⁴¹ Indeed, the THSR's core system was imported from and built by the Japanese, but some of its designs were adjusted or changed by the THSRC. Even though it was made in Japan, the THSR core system was embedded with some European designs. The THSR core system thus required a different version of the operational protocol from the Shinkansen's. Therefore, a certain amount of conflict, struggles and compromises could be observed in the building and examining process of the THSR core system. Some of them seemed to be similar with events that happened in Taiwan Railways' projects since the 1960s. They even replayed a part of Taiwanese engineering history in a short time, but more important was that they brought the history into another scenario.

6.2.1 Struggles of Integrating the Shinkansen Core system into European HSR Civil Design

To the Japanese HSR engineers, the Shinkansen was an intact HSR system in which not only did every subsystem connect to each other but every operational management depended on each other. They all together contributed to the Shinkansen's perfect performance and absolute safety in terms of high reliability and zero fatal accidents since its establishment in 1964. The Shinkansen surely advanced over time in terms of technology, but its improvements were incremental in a manner that any of its new subsystems experienced numerous tests with the other existing ones. The Japanese wanted to export an intact Shinkansen to Taiwan. However, the Japanese also understood the BOHSR and THSRC's intentions to build a hybrid HSR, so they knew their job was to install the core system instead of the whole Shinkansen to the THSR. They might have thought that they could overcome those interfacial difficulties between their core system with other civil, track and station systems.

The Japanese underestimated those interfacial difficulties among the THSR major systems, but they learned to live with this over time. In the beginning, they asked for some civil changes

⁴¹ Interviews with the THSRC engineers.

in order to fit with the Shinkansen rolling stock. The Japanese were worried that the THSR project would break their safety record and give them a negative reputation that might cause troubles for exporting another Shinkansen in the future.⁴² However, the THSRC had already started building its civil construction at the time. Moreover, the THSRC's five major constructions began their works within a very short time. The THSRC designed an intense critical path for the THSR construction.⁴³ In other words, the THSRC had very little space and intention to allow the Japanese to change some of the THSR's civil and station designs. As a result, the Shinkansen core system had to adapt to the European civil design even though the Japanese were reluctant to do so.⁴⁴

The Japanese worried that the European civil designs might be unable to present the Shinkansen core system's best performance. Other than the designs for air-tightness and train body size as noted, one of the most important differences between the Shinkansen and European rolling stock was their locomotive power design. While the TGV and ICE rolling stocks equipped two locomotives to pull and push (PP) other train cars in between, the Shinkansen distributed motor power in the some train cars (EMU, electrical multiple unit). For example, nine of the twelve train cars in a THSR 700T rolling stock equip motor power.⁴⁵ As Figure 6.11 shows, the 700T could be divided into three sets. They are sets from car one to four, car five to eight and car nine to twelve respectively. Each set of them contains a trailer cab with driving and three cars with motor power. One of the three motor cars in a set are installed with a transformer. The other two are installed with one or two traction converters and inverters. Each motor car has two power bogies. Therefore, one of the EMU rolling stock's advantages over the PP's is its acceleration and deceleration.⁴⁶ See Table 6.1 showing that the THSR rolling stock's

⁴² See Hood, chapter 8.

⁴³ An interview with CW.

⁴⁴ See Hood, chapter 8.

⁴⁵ BOHSR, *Introduction to the THSR Electrical and Mechanical Engineering and System*, 86.

⁴⁶ See Tanaka.

speed of static acceleration is higher than the TGV's. The Shinkansen rolling stock then needed no long distance design like the TGV and ICE in the station areas. Moreover, this difference also brought them different signaling designs in the stations.⁴⁷ The Japanese thus preferred not to fully adopt the THSR's European station design. The THSRC consequently agreed to make some changes in the station designs.⁴⁸

Figure 6. 11 THSR 700T Rolling Stock Formation (public domain)

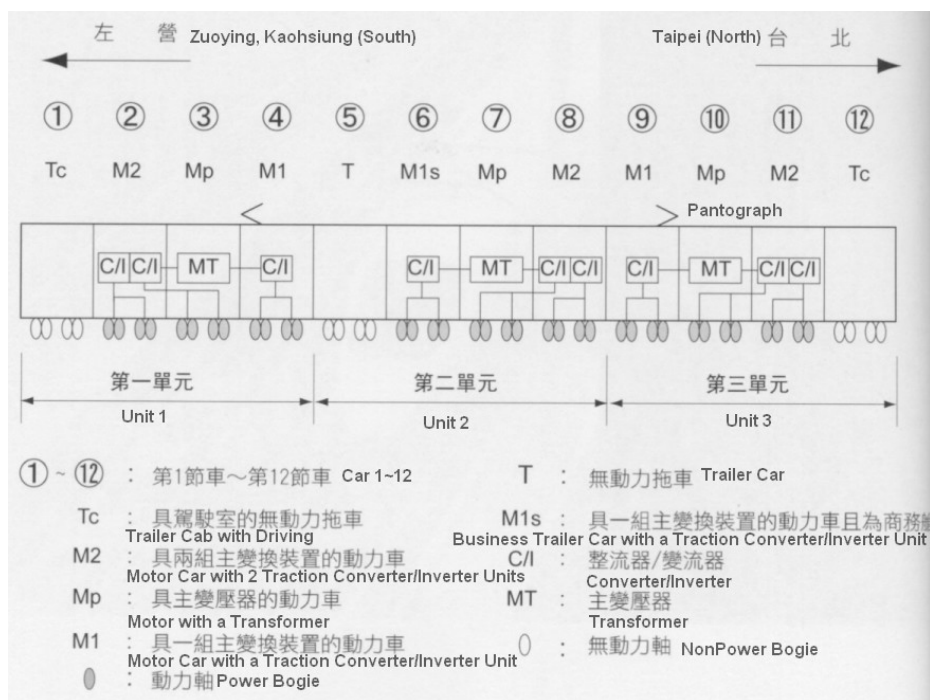

Source: BOHSR, *Introduction to the THSR Electrical and Mechanical Engineering and System*, 86.

Another conflict between the Shinkansen core system and the European civil design in the THSR project concerned the placement of the lightening conductors along the HSR railroad. The Japanese engineers could not trust the THSRC's European design and worried that this

⁴⁷ An interview with CW.

⁴⁸ *Ibid.*

European design might jeopardize the Shinkansen rolling stock and other core subsystems. The Japanese installed conduct cords into the viaduct or other civil structures in every Shinkansen line in Japan. However, the THSRC followed its European consultants' design of using the armatures inside the civil structures as the conductors. In other words, the THSRC installed no conduct cord inside the THSR's viaducts or bridge piers. It followed the European design that left a section of one armature exposed to the air in each bridge pier. The issue of the THSR's lightning conductors design between the Japanese and the European THSRC consultants thus were in a kind of a deadlock.

The Taiwanese THSRC engineers later suggested an idea to solve the problem. They proposed to install cords connecting to those exposed armatures of the viaducts. They applied the principle of electric shunt winding to attenuate electric resistance and distribute the huge amount of electricity in lightning. Both the Japanese and Europeans finally agreed with the Taiwanese engineers. However, another technical problem was that those copper cords and armatures had different melting points. In other words, it was difficult to make them attach to each other. The Taiwanese THSRC engineers then introduced a cast technique to deal with the problem. They learned this technique before from the American engineers in the Ten Major Construction's nuclear power plant project. In the end, not only was the deadlock solved but the Taiwanese engineers earned some credit.⁴⁹

6.2.2 Hybrid Engineering Struggles: Japanese Records v.s. European Simulation

Even though they mostly worked out the major conflicts between the THSR civil designs and the Shinkansen core system, the THSRC and its subcontractor for the Shinkansen core system, the Taiwan Shinkansen Consortium (Taiwan Shinkansen),⁵⁰ later confronted some

⁴⁹ Interviews with SY and JL.

⁵⁰ The Taiwan Shinkansen consisted of seven Japanese companies. They were Kawasaki Heavy Industries (川崎重工), Mitsubishi Heavy Industries (三菱重工), Toshiba Corporation (東芝), Mitsui & Co., LTD (三井物産), Mitsubishi Corporation (三菱商事), Marubeni (丸紅商事) and Sumitomo Corporation (住友商事).

serious conflicts in the process of building the core subsystems. Briefly, their different engineering thinking generated different designs. The Japanese intended to rely more on their experience, but the THSRC followed their European consultants who used to place engineering simulation and calculation prior to experience. The THSRC wanted the Taiwan Shinkansen to merge some European designs into the Shinkansen core system. This caused some serious conflicts between them at the time.

One of the most important differences between the THSR and Shinkansen core systems is their signaling systems. While the Shinkansen retained its signaling tradition of one track one direction, the THSR followed the TGV and ICE design of bi-directional signaling system.⁵¹ In other words, under some special circumstances and operation, “the up-bound train can be guided for making reverse traffic and run on the down-bound track or vice versa.”⁵² This design creates more flexibility for the THSR’s traffic control, but it needs much more complicated engineering simulation and calculation.⁵³ The Japanese manufacturers resisted changing their signaling system that had been 100% safe over the past four decades.⁵⁴ They claimed the Shinkansen uni-directional signaling system was simple and very unlikely to go wrong.⁵⁵ The Taiwan Shinkansen’s sub-manufacturer for the signaling system, Mitsubishi Heavy Industries, even released some negative information to the Taiwanese media in order to make the THSRC bend.⁵⁶ However, the THSRC still adopted their European HSR consultants’ suggestion of a bi-directional signaling system and asked the Japanese to change their mind.

⁵¹ BOHSR, *Introduction to the THSR Electrical and Mechanical Engineering and System*, 4 and 14. An interview with SY.

⁵² BOHSR, “Encyclopedia of HSR: Uni-directional Signaling & Bi-directional Signaling,” *HSR Newsletter* 8: 85 (2003): 2.

⁵³ Interviews with CW, KL, SY and YW.

⁵⁴ *Ibid* and interviews with CW, KL and AL.

⁵⁵ An interview with SY.

⁵⁶ See *Chinatimes Express*, “Wrong Marriage with Taiwan Shinkansen Making Trouble to Ing,” Sep. 9, 2005. *Liberty Times*, “Japanese Intends to Control,” Sep. 10, 2005.

In addition, the THSRC required the Japanese to digitalize the Shinkansen's conventional analog communication system for the THSR.⁵⁷ It also asked the Japanese to install staff crossing equipment that would allow technicians to cross the track.⁵⁸ These differences made the Central Japan Railway (Central JR; JR Tōkai or JR 東海),⁵⁹ who was designated to transfer Shinkansen technologies of operation and maintenance to the THSRC, very suspicious of the THSR system and THSRC.⁶⁰ A senior Taiwanese THSRC engineer revealed in an interview that the German and Japanese engineers have very different engineering philosophies in the case of the THSR signaling system. While the Japanese relied more on their engineering experience and records, the Germans tended to apply more engineering simulations in their engineering practices.⁶¹

Nevertheless, the THSRC did not completely copy all of the European suggestions in designing its signaling system. It also adopted some of the Shinkansen designs. For example, one of the previously noted twenty-six differences was the THSRC's intention to equip axle counters in order to allow the THSR rolling stock to run at speeds of 120 km/hr, unlike the Shinkansen which could only run at 30 km/hr, if the major signaling system is out of order.⁶² "In the railway signal system, the rail is generally utilized the transmit signals, it is known as the 'Track Circuit.' The axle counter is normally used to detect whether the track is occupied by a train or not, which is similar to a track circuit."⁶³ However, the Japanese engineers thought that

⁵⁷ An interview with YW. *Chinatimes Express*, on Sep. 9, 2005. *Taiwan Next Magazine*, "Jpn Pro: Ing Building Dangerous THSR," Dec. 2, 2004.

⁵⁸ See *United Daily*, "MOTC Favor Japanese: Okay with THSR Core System Following Jpn Design," Mar. 18, 2005. Also see BOHSR, *Introduction to the THSR Electrical and Mechanical Engineering and System*, chapter 3. According to KL, the Japanese government does not allow any person across the HSR track in order to avoid any possible accidents.

⁵⁹ The Central JR is responsible for running the Tōkaidō Shinkansen. See Central Japan Railway Company, "Company Profile: Operating Area," <http://english.jr-central.co.jp/company/company/about/area.html>

⁶⁰ See Tanaka.

⁶¹ An interview with SY.

⁶² See *United Daily*, Mar. 18, 2005.

⁶³ "The operation principle of the axle counter is that it needs to install magnetic heads at each side of the steel rail for transmitting and receiving signals. In the mean time, it needs an indoor facility consists of computers and related control circuits to work with. By the train there is a train enter into a track block, the axle counter is counted by adding it up progressively. When a zero counting result is found at both beginning and terminal points of a track block it means there is no train occupying on such track block and thus it is allowable to bring in the next train."

adding axle counters as a second signaling system to the THSR was a waste. The track circuit was reliable enough to do the signal transmission job. In the end, the THSRC did not insist on installing axle counters and adopted the Japanese HSR engineers' suggestion.⁶⁴

In addition, another situation arose when the Japanese manufacturer followed the THSRC's requirement to make some European designs but they were suggested not to use them. For example, the THSR's staff crossing equipment has been disabled until now. This was mainly because the Shinkansen has no such design and the Central JR thought this device might cause unnecessary danger. The THSRC might be under the Central JR's pressure. It might also realize that the THSR's interval train services would be as intense as the Shinkansen's. This equipment, thus, might bring little benefit to the THSRC.⁶⁵

Although they attempted to work out those interfacing difficulties, the THSRC and Taiwan Shinkansen still paid a serious price for their earlier confidence in the subsystems' interfacial integration. The THSR's scheduled launch date was postponed one year from October 2005 to October 2006.⁶⁶ Nita Ing explained this delay was based on the THSRC's general considerations of construction progress, system testing and operation preparation. However, the more specific reason was believed to be that the THSRC needed more time to integrate the Shinkansen core system with the European designs.⁶⁷ The task of interfacing the signaling and communication subsystems was among the key parts that caused to the delay.⁶⁸ The THSRC pointed out that the Taiwan Shinkansen's construction work was 30% behind the planned schedule at the time and it would be blamed to take the full responsibility.⁶⁹ The MOTC also changed its earlier friendly

BOHSR, "HSR Encyclopedia: Axle Counters," *HSR Newsletter* 10: 113 (2005): 16.

⁶⁴ An interview with KL. Also see BOHSR, *Introduction to the THSR Electrical and Mechanical Engineering and System*, chapter 3.

⁶⁵ An interview with KL.

⁶⁶ See *Central News Agency*, "Nita Ing: One Year Delay of the THSR's Open to Traffic," Sep. 8, 2005. BOHSR, *Current THSR Construction*, 6.

⁶⁷ *Ibid* and see *United Daily*, "Delay Due to Core System Work Serious Behind," Sep. 9, 2005.

⁶⁸ See *Liberty Times*, "MOTC Impugned the Japanese for THSR's Delay," Sep. 7, 2005.

⁶⁹ *Ibid*. Also see *Central News Agency*, "THSR Core System Progress Less than 40%," Sep. 6, 2005. *Chinatimes*,

attitude to the Japanese and joined the THSRC in impugning the Japanese subcontractors, saying they should have evaluated those interfacial technical difficulties and problems before competing for the THSR core system.⁷⁰ Although it had no specific comment on the delay, the Taiwan Shinkansen promised to catch up with the planned schedule as soon as possible and hoped the THSRC would not ask for compensation.⁷¹

6.2.3 Hybrid Engineering Struggles: Trust v.s. Cybernetics

Another conceptual conflict between the THSR and Shinkansen operations was that while the latter placed more value on trained staff, the former intended to rely more on technology in the HSR operation. Some examples as noted have displayed the differences in HSR engineering designs between the European HSRs and the Shinkansen. These differences extended to their practical operations and maintenance, which in turn caused some conflicts between the THSRC and Central JR.

As one of the twenty-six differences between the THSR and Shinkansen, the THSRC required the installation of a warning device for the THSR conductors on the Shinkansen 700T. If they did not hold the speed accelerator still for some certain period of time, the operating THSR conductors would receive a warning alarm in case they fell asleep. If they still did not notice the alarm, then the central traffic center would take control of the train. A senior THSRC engineer and manager said, “One of the THSRC’s intentions has been to apply technology in order to prevent human mistakes. Even though a few failures might happen, they would still be directed towards safety (Fail Safe).”⁷² However, the Shinkansen has no such device because the

“THSRC Complained Taiwan Shinkansen Altitude,” Sep. 8, 2005. *Liberty Times*, “Nita Ing: Sorry for the THSR Delay,” Sep. 9, 2005.

⁷⁰ *Ibid.*

⁷¹ See *Chinatimes Express*, on Sep. 9, 2005.

⁷² *Ibid.*, 171.

Japanese rely highly on their conductors' professional discipline and work attitude. Their training leaves their conductors no chance to fall asleep when operating the HSR train.⁷³

“This represented a kind of cultural difference [between Taiwan and Japan],”⁷⁴ a THSRC subcontractor said. Although those twenty-six differences were mainly based on the European designs, it was the THSRC's intention to adopt them instead of copying everything from the Shinkansen. In addition to some of the European cybernetic designs, the THSRC also introduced Hong Kong Transit's maintenance management into the THSR. Hong Kong Transit applied a complicated computer and database system to simulate and conduct its maintenance planning and cost-benefit analysis. Even though it still sends its staff to get technical training with the Shinkansen HSR in Japan, the THSRC has been seeking and integrating another management system for maintenance of the THSR.⁷⁵

6.2.4 Hybrid Engineering Struggles: Specific v.s. Diverse Experiences

The THSR's maintenance and repairing work might involve more of the Taiwanese THSRC engineers' direct participation than the other major works in the core system, such as system interfaces, parameter collection, operation training, management system set-up and verification and validation (see next section) etc. Although its foreign consultants still took the main review responsibility, the THSRC's Taiwanese engineers were the actual manpower conducting its repairing and maintaining jobs.⁷⁶ Basically, they received most of the critical HSR engineering training from the Japanese, but they also brought some of their own practical experiences into the THSR maintenance.

The Japanese were impressed, among other things, by the THSRC Taiwanese engineers' engineering abilities in terms of bug checking. The THSRC Taiwanese engineers sometimes

⁷³ See Tsao-Yi Wu, 170~1.

⁷⁴ *Ibid.*

⁷⁵ An interview with YW.

⁷⁶ An interview with YW. According to YW, the foreign THSRC engineers came from such places as Germany, France, the U.K, the U.S., Philippine, Malaysia and Hong Kong etc.

even offered some solutions to eliminate the bugs in the core system. For example, the connecting cables and cords between the Shinkansen trains were usually sleeved in order to prevent them from generating sparks caused by the heat contact between the catenary cables and pantographs. These sleeves, however, were often cracked and even torn off because of the constant vibration between trains during operation. The Taiwanese THSRC engineers thus suggested that cover lids be installed to protect those cables and cords.⁷⁷ Nevertheless, sometimes the Japanese preferred to keep their conventional practices, because they trusted their experience and records, which had no significant problems for years.⁷⁸

“The Taiwanese engineers have been good at detecting and eliminating bugs. Their past hybrid cooperation with other professional engineers offered them a fruitful mix of experiences, which sometimes facilitated the Taiwanese engineers to find bugs through different engineering perspectives.”⁷⁹ However, another senior THSRC engineer criticized the Taiwanese engineers, charging that their engineering knowledge may have more breadth than depth.⁸⁰ They might have placed more interest in hybridizing different engineering practices than narrowing down into one specific profession. Taiwan’s special social and historical circumstances might have driven this preference. This preference, nevertheless, evolved over time. For example, the THSRC Taiwanese engineers should have no problem with maintaining and repairing the THSR’s power supply subsystem at present because it has acquired well trained local electrical engineers. The main reason that Taiwan could develop decent electrical engineers was that Taiwan’s power industry grew nicely because of U.S. assistance since the 1960s.⁸¹ While they learned the engineering profession under the dominant control, Taiwanese power engineers also

⁷⁷ An interview with SY.

⁷⁸ An interview with YW.

⁷⁹ An interview with SY.

⁸⁰ An interview with RL.

⁸¹ An interview with YW. Taiwan has been well known for its power engineering since the 1970s. This has some historical background. See more on this in chapter 3 and 4.

gradually forged their expertise and experience from the bottom and piece by piece over years. In the end some of them even exported their experience to Africa.⁸² The THSRC Taiwanese engineers might inherit this tradition and develop their expertise from building something piece by piece to as a whole system in the future.

6.3 Pursuing Non-dependent Maintenance

The conflicts between the THSRC and Taiwan Shinkansen extended from the THSR's hardware to soft techniques. When the THSR project approached its end, how to operate and maintain the THSR emerged to be one of the most important and controversial issues. Nita Ing's constant insistence on protecting and producing the THSRC's leading power over the Taiwan Shinkansen might have contributed to the creation of a more intense relationship than they had before. She not only wanted the THSRC to be able to make engineering specifications and designs in the civil construction, but also attempted to have its future core system with independent operation and maintenance. "If the THSRC were to lose the leading power in the project," she claimed, "the THSR's operation and maintenance systems would be under foreigners' control for fifty or even one hundred years in the future. This was the thing we needed to defend for the THSRC and our country's present and future."⁸³

The Taiwan Shinkansen's organizational structure made the conflicts with the THSRC more complicated especially with regard to THSR operation. The Taiwan Shinkansen was mainly a manager of the Shinkansen core system for the THSRC. It built the THSR core system by subcontracting several minor projects to its member manufacturers. The Taiwan Shinkansen also commissioned Central Japan Railway to transfer the Shinkansen's maintenance techniques and operation training to the THSRC.⁸⁴ In other words, while the European consultants helped

⁸² See Su-Fen Liu, chapter 15.

⁸³ See Tsao-Yi Wu.

⁸⁴ See *Central News Agency*, "MOTC Complained Taiwan Shinkansen Irresponsible Words," Apr. 24, 2006.

the THSRC design the THSR independently, Central JR was responsible for making it run the THSR autonomously with the Euro-Shinkansen facilities.

However, Central JR did not have enough incentive to help the THSRC out. It was allegedly designated by the Japanese government to participate in the THSR project.⁸⁵ Unlike those seven Japanese companies that consisted of the Taiwan Shinkansen, Central JR understood that they would gain no real profits from the project, but had to transfer its precious forty-year running experience to the THSRC.⁸⁶ Besides, as noted, Central JR was very confident about the intactness of the Shinkansen system. “It is like caring for a baby,” Li-Liang Chou (周禮良; the Deputy Minister of MOTC at the time) said, “they [the Japanese] would be upset if we take care of the Shinkansen in a different way,”⁸⁷ Thus, Central JR was reluctant and resisted the THSRC’s independent policy of bringing some European designs and ideas into the Shinkansen core system.⁸⁸ Although the THSRC European consultants mainly offered engineering suggestions about the THSR’s hardware, different HSR hardware would inevitably require different software, management and operation systems. For example, the THSR’s bi-directional signaling and staff crossing designs, among other things, changed the Shinkansen’s conventional protocol of traffic control.

Hiroyoshi Tanaka (田中昌宏), a senior engineer sent by Central JR to the THSR project, claimed that the THSR might adopt approximately 30% of the European system and 70% of the Japanese Shinkansen system. Although they could provide some operation suggestions, Central JR could not offer relevant experiences to the THSR regarding to those twenty-six differences from the Shinkansen. For example, while the Shinkansen conductors could order all train’ doors

⁸⁵ See *Chinatimes Express*, on Sep. 9, 2005. *Central News Agency*, “MOTC Warned Taiwan Shinkansen for THSR Conductor Training,” Apr. 24, 2006. *BCC News Network*, “MOTC Accused the Central JR, Even the Japanese Government No Power over Central JR,” Apr. 24, 2006.

⁸⁶ *Ibid* and footnote 68 and 69.

⁸⁷ Tsao-Yi Wu, 171.

⁸⁸ *Ibid* and *BCC News Network*, Apr. 24, 2006.

to open only from the first train car, the THSR applied the TGV design where its conductors could give the order to open them from any one of the train cars. In addition, unlike the Shinkansen conductors' independent operation, the THSR conductors need the station staff to help them park the trains in the correct position in the stations. Tanaka thus pointed out determining how to integrate the hybrid European and Japanese system would be one of the most critical issues for the THSRC and its subcontractors.⁸⁹ This released information raised huge debates, concerns and questions in Taiwan, especially at a time when the THSR project was approaching completion.⁹⁰ Moreover, Central JR later would not allow the conductors trained by the THSRC to operate the Shinkansen S700 rolling stock in Japan. They were only allowed to observe the Japanese conductors driving the S700. These unfriendly moves from Central JR finally induced a BOHSR counter stroke. The BOHSR Director General at the time, Nuan-Hsuan Ho (何煖軒), publicly accused Central JR of having a hostile attitude to the THSRC.⁹¹ As a result, although the Taiwan Shinkansen contracted with Central JR, the THSRC had serious trouble working with Central JR.

Some high level THSRC and MOTC officials flew to Japan in order to negotiate with Central JR in March and May 2005. They also invited the Taiwan Shinkansen, the Japanese Ministry of Land, Infrastructure, Transport and Tourism (Japanese Ministry of Transport; 国土交通省) and the JR-W (West Japan Railway Company) to join their meetings.⁹² Nevertheless, those seven Japanese Taiwan Shinkansen companies and even the Japanese Ministry of Transport had little power over Central JR, because it has been the most powerful and profitable railway company in Japan. Those seven companies felt they might still need Central JR's

⁸⁹ See Tanaka.

⁹⁰ See *United Daily*, "Japan Professionals: Problems of the Euro-Jpn Hybrid THSR," Nov. 28, 2004. *Central Daily News*, "Central JR Refused to Endorse the THSR," Jan. 28, 2005.

⁹¹ See footnote 66 and 68. Also see *Taiwan Daily*, "MOTC Seeking Jpn Help," Apr. 26, 2006.

⁹² *Ibid.* Also see *Chinatimes*, "THSR Miserable Fate Caused by Derailed Relationship between Taiwan and Japan," June 21, 2005. *United Daily*, "Taiwanese and Japanese Governments Help the THSRC," Oct. 1, 2005.

business in the future. Some of the key officials in the Japanese Ministry of Transport even served originally in Central JR.⁹³ Like some other Japan Railway companies, in addition, after Central JR became a privatized corporation, the Japanese Ministry of Transport had less and less ability to influence it. In the end, the Japanese Ministry of Transport skipped over Central JR to establish a unit that offered assistance to the THSRC in order to make the first Shinkansen export successful. The Executive Yuan later also demanded the MOTC to organize a THSR team to assist the THSRC.⁹⁴

After the Central JR team left it at the end of June 2005, the THSRC relied on itself to draft the operation regulations and to conduct staff training for the THSR.⁹⁵ Among other things, the THSRC struggled over acquiring the HSR conductors for its Shinkansen 700T rolling stock. As noted, the THSRC's Taiwanese intern conductors had no chance to operate Central JR's Shinkansen S700 in Japan, despite there being only a few differences between it and the 700T. The THSRC therefore hired thirty-nine French and thirteen German licensed HSR conductors in August 2006.⁹⁶ In addition, it also acquired some foreign HSR central traffic controllers, station operators and other professional staff from France, Germany, Canada, Japan, Hong Kong and the U.S.⁹⁷ As a result, the Taiwanese public expressed great concern about this multi-lingual operation.

However, the Taiwanese should have become accustomed to this *international phenomenon* in their memories. The Taiwan Railways has been well known in Taiwan in terms of its hybrid engineering and operation. Only speaking of its locomotives and trains, the Taiwan Railways has imported and maintained them not only from the U.S., U.K. and Japan, as noted in

⁹³ See *BCC News Network*, Apr. 24, 2006.

⁹⁴ See *United Daily*, Oct. 1, 2005.

⁹⁵ *Ibid.* Also see *United Daily*, Sep. 9, 2005 and *BCC News Network*, "Hardly Solvable THSR Problems between Taiwan and Japan," Apr. 26, 2006.

⁹⁶ See *Central News Agency*, "High-Speed Rail to Hire 52 Foreign Train Conductor," Aug. 28, 2006.

⁹⁷ See *United Daily*, "BOHSR: Hardly Launch in October 2006," May 3, 2006.

<http://www.iot.gov.tw/ct.asp?xItem=147452&CtNode=1066>

chapter two, but also from South Africa, Germany, Italy, and Korea.⁹⁸ The engineers from these countries brought their operation and engineering practices into Taiwan, and the Taiwan Railways in turn absorbed and integrated these experiences into their professions. Although the Taiwanese used to tease the Taiwan Railways that they were like the United Nations, the Taiwan Railways seemed to be unable to free their operation and practices from this comment. Its engineering practices and operation might have been shaped by Taiwan history. However, the more interesting phenomenon here is that the THSR seemed more and more to resemble the Taiwan Railways. Some of the Taiwanese media have started calling the THSR another United Nations as well.⁹⁹

6.4 Engineering Hybridizer or Butcher?: Challenges, Risks and Cost

Some of the Taiwanese THSRC and CECI engineers claimed that their cooperation with the Japanese and other foreign engineers has benefited their engineering skills, experience and abilities.¹⁰⁰ They learned not only those foreigners' different engineering methods, practices and philosophies, but also how to take advantage in the four-party negotiations. First, the THSRC sometimes used its foreign consultants and the Japanese HSR engineers to prevent it from some domestic intervention. They could more easily find ways to keep unqualified or notorious local constructors away from the THSR project.¹⁰¹ Second, the THSRC used the European engineers to make the Japanese leave and even produce some of the Shinkansen's engineering designs, data and parameters. The Japanese struggled to follow this THSRC's demand since some of their engineering practices were based on their past experiences and records. For example, they had not even turned some of the Shinkansen records into engineering parameters previously.¹⁰²

⁹⁸ See the Taiwan Railways Online Museum at http://www.railway.gov.tw/i/i5_01.htm

⁹⁹ See Danny Lee (李丹妮), "Taiwan Railways' Taroko Express Launch in April," *New Taiwan Weekly* 572 (2007). *Taiwan Shin Sheng Daily News*, "Local THSR Conductors Begin to Serve," May 24, 2007. *Nownews*, "THSR Traffic Control Center Exposed," Nov. 29, 2006.

¹⁰⁰ Interviews with some THSRC engineers.

¹⁰¹ An interview with RW.

¹⁰² An interview with SY.

A Taiwanese HSR engineer revealed a metaphorical story in the THSRC that, while the Japanese engineers would show the records of when eggs broke under what kind of practical circumstances, the THSRC European consultants wanted the Japanese to calculate when eggs would be broken under what kind of physical conditions.¹⁰³

Thus the THSRC might be able to acquire a sort of “system assurance,” by which the THSRC could accumulate and analyze its core system’s engineering data and then create some possibilities for developing some HSR technologies in Taiwan in the future.¹⁰⁴ Taiwan might not be capable of exporting a different core HSR technology in a short time, but it could offer some negotiating experiences between the Japanese and Europeans during the THSR’s building and running stages. However, the THSRC still needed to spend more time and devote more effort to keeping its maintenance independent. As a Taiwanese THSRC engineer responded in his interview, “we still need some more time to be away from an unpleasant metaphor of *engineering butchers* that has unfortunately characterized we Taiwanese engineers for a long time.”¹⁰⁵ He mentioned this when he was talking about how the THSRC kept one set of the thirty rolling stocks for the other twenty nine sets’ maintenance and repair. That set was arranged in the depot and prepared to be dissected into pieces in order to replace those broken parts in any one of the other sets. It might be proper to relate this THSRC engineer’s concern to Tong’s early engineering cannibalism that I describe in chapter three. However, this THSRC engineer has come to examine the notions of engineering butchery or cannibalism and offered some ideas to change or upgrade these notions according to his engineering experience developed in the past two decades. He said, “although we Taiwanese engineers might still confront difficulties in making the HSR’s systematic interfaces, the THSR should be able to soon

¹⁰³ An interview with KL.

¹⁰⁴ An interview with AL.

¹⁰⁵ *Ibid.*

pick up its engineering data and maintenance experience and then encourage Taiwanese manufacturers to make some of the components for its core system.”¹⁰⁶

After reviewing their building process, nevertheless, some of the Taiwanese THSRC engineers also expressed that their hybrid policy might have been a mistake.¹⁰⁷ They realized that they wasted one more year on the core system integration. This cost their company, the THSRC, a significant amount of money, time and human resources etc. Moreover, as noted in chapter five, the BOHSR Director General Chung-Yih Lin was accused by his supervisor, the MOTC Minister Tsai, that he spent too much budget and time on designing and planning the Taiwan HSR civil structure that attempted to include all potential HSR core system providers able to install their systems on it. I argue this situation was mainly caused by Taiwan’s engineering culture instead of Lin’s leadership. The Taiwanese engineering culture of hybridity might contribute to a waste of some resources and cause project delays.

In addition, some THSRC engineers revealed to me that the THSRC had to rely much more on its foreign engineers for the core system than the other major systems.¹⁰⁸ The THSRC only hired forty plus of the Taiwanese engineers for its core system unit and most of them were subject to those foreign consultants in the company. In addition, they also experienced that they had few chances to learn and acquire those HSR core interfacing techniques from either the Japanese or the foreign consultants in the THSRC.¹⁰⁹ The Taiwanese THSRC engineers thus worried that they might be unable to develop some of the key HSR inter-systematic technologies, even though they and other Taiwanese manufacturers could make some components in the near future.

¹⁰⁶ *Ibid.*

¹⁰⁷ Interviews with CW, YW and RW.

¹⁰⁸ *Ibid.*

¹⁰⁹ An interview with SY.

The THSR project might have shown a traditional engineering trajectory like the Taiwan Railways, in which the THSRC might be able to develop some HSR techniques and equipment through its maintenance instead of in its early transfer stage. In other words, the Taiwanese THSRC engineers were more likely to acquire transferred technologies from a bottom-up approach in that they dissected them into pieces and then attempted to maintain and make them. They also found their bugs and improved those pieces. However, the THSRC might have no interest and ability to do HSR interfacing research and development. This might not only be because the THSRC is a private and commercial company whose intentions have been to stay focused on making maximum profits during the concession period,¹¹⁰ but also the THSRC has inherited Taiwan's bottom-up engineering culture.

Unlike the roles of CICEs, ICEs and ISEs in the civil, track and station projects, the THSRC contracted the British Lloyd's Register of Shipping (Lloyd's Register) as the independent third party to verify and validate the whole THSR project in July 2000.¹¹¹ Lloyd's Register later invited AEA Technology Rail and Tony Gee and Partners¹¹² together to organize the Lloyd's Register Project Team conducting the THSR's independent verification and validation (IV&V) job.¹¹³ The verification is "a confirmation process of analysis and testing to see if a product or engineering was correctly engineered during each stage of planning, design, construction, testing and integration and met the requirements being set at the previous stage."¹¹⁴ The validation is "a process of analysis and testing to see if a completed product or engineering

¹¹⁰ Interviews with the Taiwanese THSRC engineers.

¹¹¹ BOHSR, *Introduction to Full-span Precast & Launching Method*, 16.

¹¹² Both the AEAT and TPG are British engineering consultants. "TGP brought experience in the areas of viaduct and station design and construction to the group and employed specialist sub-consultant Dr Sauer for assistance with the demanding geotechnical and tunneling elements of the project." See more information at AEA website, <http://www.aeat.co.uk/cms/> and Tony Gee and Partners, "Taiwan High Speed Link," <http://www.tgp.co.uk/services/projects/taiwan.html>

¹¹³ Song-Tzoo Wu, 187.

¹¹⁴ BOHSR, "What is the Independent Verification and Validation (IV&V)?" *HSR Newsletter* 7: 80 (2002), 7.

work is correct and meets the system requirements and goals.”¹¹⁵ This is sometimes expressed as “Are we building the system right?” and “Are we building the right system?” See Figure 6.12 Relations of CICE, ICE/ISE and IV&V in THSR Project. This THSR IV&V demand was written in the BOT contract. The BOHSR wanted the THSR to be able to be verified and validated by a third party who applied those V&V processes and techniques referring to aviation, shipbuilding, military and nuclear power plant industries.¹¹⁶

Generally, most of the conventional railways have to be engineered with the natural considerations of various landforms and climates. Moreover, they need to adapt to social milieu since they need to be run and maintained by plenty of local people. HSRs are similar to conventional railways. Those engineering differences among the Shinkansen, TGV and ICE in terms of specifications and practices can be observed in Table 5.1 and 6.1. These engineering differences often come from different philosophies of how their engineers conceived of railway operation, management and maintenance. Therefore, most of the advanced countries have their railway administrations, companies or other local professional engineering agencies to verify and validate their newly established railways. This is mainly because they are the only institutes who have the relevant experts and experienced engineers able to do the V&V job.¹¹⁷ For example, Taiwan Railways has established some departments to do most of the V&V job with the MOTC. All Shinkansen lines also invite their common builder the Japan Railway Construction Public Corporation (日本鉄道建設公団) with its administration (the Japanese Ministry of Transport; 運輸省) and their different users (the six area Japan Railway companies) to do their V&V job.¹¹⁸

¹¹⁵ *Ibid.*

¹¹⁶ See BOHSR, “Taiwan South-North High Speed Rail Construction and Operation Contract,” section 1.

¹¹⁷ See Song-Tzoo Wu and interviews with Ming-Ren Huang and Tsuei.

¹¹⁸ Yung-Yi Chen (陳永毅) and Chao-Lung Tsai (蔡朝榮) (BOHSR engineers), *Interfacial Integration and Management in the Building Process of HSR Civil Construction and Core System* (Taipei: BOHSR, 2004), 27~8. The Japan Railway Construction Public Corporation transformed to the Japan Railway Construction, Transport and Technology Agency (独立行政法人鉄道建設・運輸施設整備支援機構) in 2003. In addition, the Ministry of Transport was reorganized as the Ministry of Land, Infrastructure, Transport and Tourism in 2001. “According to the Japanese Nationwide Shinkansen Railway Development Law, the Japan Railway Construction, Transport and

Figure 6. 12 Relations of CICE, ICE/ISE and IV&V in THSR Project

(used under fair use guidelines)

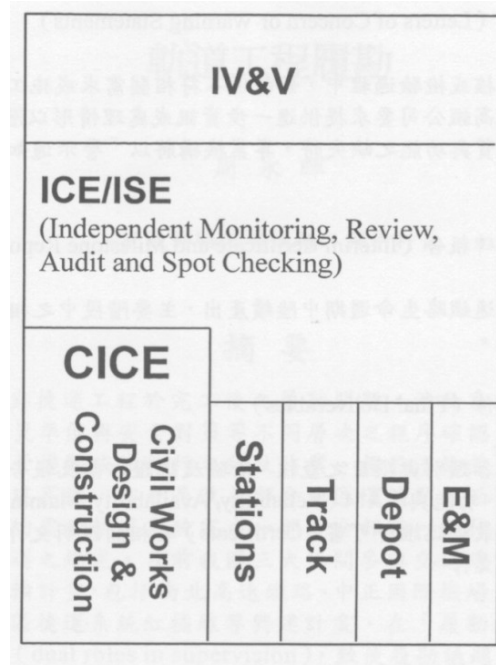

Source: Song-Tzoo Wu, “Independent Checking, Verification and Validation,” in *Proceedings of Rail Engineering Society of Taiwan (RESOT) Annual Meeting 2002* (Taipei: RESOT, 2002), 191.

The THSR was the first Shinkansen system that was verified and validated by a non-Japanese institute.¹¹⁹ At the beginning of the THSR project, as noted, the Japanese were full of confidence based on their almost perfect record over the past four decades. They were also very cautious about getting things right on this first Shinkansen export. However, the Japanese later suffered many more struggles than they expected in the THSR’s V&V process.¹²⁰ The Japanese

Technology Agency promotes the construction of new Shinkansen lines and other traditional railways.” See http://www.jrtt.go.jp/news/news_english.htm Also see Japanese Ministry of Land, Infrastructure, Transport and Tourism, *Brochure of Ministry of Land, Infrastructure, Transport and Tourism* <http://www.mlit.go.jp/common/000047294.pdf>

¹¹⁹ See Tsao-Yi Wu.

¹²⁰ *Ibid* and an interview with Tsuei. Tsao-Yi Wu’s article quoted the second Director General of the BOHSR, Nuan-Hsuan Ho, who said that “It was Japan’s first time to export the Shinkansen system. They (the Japanese) did not expect that their system should go through the IV&V. The IV&V work took us a lot of time.” However, the THSRC contracted with Lloyd’s Register in 2000, before the Taiwan Shinkansen started the core system construction in 2001. The Japanese should have known their system would be verified and validated by Lloyd’s Register from the beginning. So I mainly adopted Tsuei’s interview that the Japanese suffered more struggles than they expected.

even resisted the V&V because they worried that their business secrets might be stolen in the process.¹²¹ It was reported in newspapers that Mitsubishi Heavy Industries refused to offer the detailed design of the THSR signaling system.¹²² The THSR project, nevertheless, also brought the Japanese some positive experience. Hayao Hora (洞駿), the Deputy Minister of the Japanese Ministry of Transport, commented about the THSR project, “we should take the issues brought by different natural geographies and local culture into account for our future Shinkansen export.”¹²³ The Japanese have acknowledged that they will confront similar issues of system integration that occurred in the THSR project again in the future.¹²⁴

As a result of the IV&V policy, Bol-Yi Tsuei claims that the THSR might be “redundant designed,” because it not only satisfied the functional and technical requirements from the THSRC but also got through the V&V examination conducted by Lloyd’s Register. The THSR project, Tsuei continued, might have created an unprecedented international mechanism of “technology transfer plus the IV&V (TechTransfer+IV&V).” In other words, technology transfer was not simply a process of exporting and importing technology between the two principal countries. Rather, it needs to be localized, adjusted, changed and even upgraded by the local engineers. Furthermore, it has to be verified and validated by a third party from a different country. The transferred technology should be examined by all of them. For example, the THSRC applied all of the strictest standards, either from the Shinkansen, THSRC or Lloyd’s Register, to verify and validate the THSR. The THSR thus might achieve a maximum satisfaction of engineering design in terms of RAMS (reliability, availability, maintainability and safety).¹²⁵

¹²¹ See Danny Lee, “Adamant to Do IV&V for THSR Safety,” *New Taiwan Weekly* 554 (2006).

¹²² *United Daily*, on Sep. 9, 2005.

¹²³ See Tsao-Yi Wu and *Asahi Shimbun* (日本朝日新聞), “First Shinkansen Export: THSR Trial Operation in March (初輸出新幹線、軌道乗るか 台湾で試験走行 3 カ月遅れ),” Feb. 11, 2005.

¹²⁴ See *Central News Agency*, “Japan Press Applauds THSR Open to Traffic,” Jan. 5, 2007.

¹²⁵ An interview with Tsuei. Goncalo Medeiros Pais Simoes defined the RAMS as, “RAMS techniques have been extensively applied to the electro technical engineering field. They have a high potential for application in the rail

Only when both the private sector and the government demonstrated sufficient strength could the mechanism of the TechTransfer+IV&V be possible in the THSR project. First, as noted, Nita Ing's insistence that the THSRC should have more leading power over the Taiwan Shinkansen in the THSR project contributed to the realization of this mechanism. In addition, requiring the transferred Shinkansen system to be verified and validated by a third party was one of the BOHSR's fundamental policies. Both the THSRC and BOHSR adamantly shared and practiced the mechanism of the TechTransfer+IV&V. Their BOT THSR contract reveals this policy.

The "TechTransfer+IV&V" and "redundant design" practices might further imply a conflict phenomenon in the THSR project and even in Taiwanese engineering culture. While they were working on changing or redesigning those transferred technologies in the THSR project, Taiwanese engineers lacked the confidence to verify and validate them. The THSR project was not the first case of meeting this conflict. Tsuei mentioned that the Americans had introduced RAMS techniques to Taiwan years ago.¹²⁶ Taiwanese engineers have been used to working on over-designed projects previously. Moreover, Ing's independent intention could be seen in Taiwan Railways projects as well. Taiwanese engineers have been capable of converting some of the transferred technologies. However, they were not yet confident about conducting the V&V job. Nor did the Taiwanese government and society trust local engineers to conduct the job. Therefore, THSR's conflict phenomenon has existed for years in Taiwan.

As a result, the TechTransfer+IV&V mechanism observed in the THSR project was not only a local but also a historical product. This mechanism required both strong local political

infrastructure management field but they currently lack standardization and stated procedures for the correct study of RAMS parameters. RAMS techniques allow reliability engineers to forecast failures from the observation of operational field data. RAMS parameters which may be forecast are reliability, availability, failure rate, mean time between failures, mean down time, among others." See more Goncalo Medeiros Pais Simoes, "RAMS analysis of railway track infrastructure" (Master thesis, Instituto Superior Técnico, Lisboa, Portugal, 2008).

¹²⁶ An interview with Tsuei.

power to support it and the constant ability of accumulation to construct it. This locally and historically enhanced “TechTransfer+IV&V” might have been an engineering culture special to Taiwan. This culture would bring Taiwan some independence, but it caused some conflicts as well. The THSR project has produced engineering independence and has pushed engineering conflict more explicitly than previous projects in Taiwan, because it was the most phenomenal project in Taiwanese history and the largest BOT project in the world at the time.¹²⁷

Another problem related to the engineering culture of hybridity could be connected to the notorious issue of political patronage in Taiwan. As noted in chapter two, some major infrastructure projects in Taiwan were often divided into several subsystems or small projects since the 1960s. This phenomenon of project partitioning has lasted until the present; even the THSR project was unable to be exonerated in some cases. However, this unpleasant phenomenon has been changed in terms of involving partitioning parties. While several of Taiwan’s infrastructure projects were partitioned by the firms from advanced countries, a number of them were cut into pieces by some local companies in Taiwan. As noted, most of Taiwan’s local companies were unable to take the whole infrastructure project, so they often worked together to divide the project into several parts by which every participator could share a cut. In addition, they usually cooperated with some local politicians to realize their plans. This situation could be detected more often and easily in the local government’s public projects. As a result, a certain number of the infrastructure projects in Taiwan have raised some political and business struggles. Moreover, some of them were built in low-quality hybridization. The engineering culture of hybridity and political patronage thus sometimes merged together. However, this situation has jeopardized the engineering quality and effectiveness of those public projects. Moreover, to some degree, the political patronage sometimes even drove and forged

¹²⁷ See BOHSR, “Viewpoint,” *HSR Newsletter* 9: 107 (2005): 2.

the engineering culture of hybridity, by which local politicians could extract more benefits from the government.

Although Ing adamantly insisted on the THSR's non-dependence, as noted, the THSRC still confronted some significant challenges and difficulties when the Japanese left. The vision of technological non-dependence still has some distance to go and needs some time to be achieved. On the one hand, with hardware technology, the bottom-up engineering strategy might have worked before, but it will face critical challenges especially when China recognizes that it will be able to take some market from Taiwan in a short time. On the other hand, with software or management technology, the THSRC has found some serious management flaws in terms of lack of professional training or duty discipline since the THSR opened to traffic in 2007.¹²⁸ How to manage technology appropriately is still one of the most critical issues that technology importers need to make an effort to solve.

6.5 Best Mix or Localized Hybrid?

Nita Ing argued that the THSR's core system was no Euro-Jpn hybrid, but the THSRC publicly claimed it was a "Best Mix" after it incorporated the twenty-six European designs into the Shinkansen.¹²⁹ Although some even teased that the THSR core system was a "Bad Mix,"¹³⁰ the BOHSR proclaimed that the THSR project "utilizes global resources, experience and technology [by which] the THSR combines electronic control system of European railway with the security and precision of the standard of the Japanese Shinkansen system."¹³¹ No matter how to metaphorically describe it, a hybrid, a best/bad mix or a combination of the two, the THSR core system was no Shinkansen copy. It was not even close to being another TGV or ICE. Ing

¹²⁸ See *Apple Daily*, "500 Passengers in Serious Risk, THSR Conductor Allegedly Fell in Sleep while Operating," May 10, 2010. *Chinatimes*, "13 Mins without Conducting on THSR Train," May 10, 2010. *United Daily*, "THSR Conductor Violated Duty Discipline in Operation," Mar. 25, 2009. *United Daily*, "THSR Booking System Hacked," Jan. 6, 2008.

¹²⁹ Tsao-Yi Wu, 169.

¹³⁰ *Taiwan Next Magazine*, Dec. 2, 2004.

¹³¹ BOHSR, "Viewpoint," 2.

was not wrong in terms of original product-making. The THSR core system was made in Japan. However, it contained some significant European designs in terms of engineering design, system operation and business regulation. As a result, we have seen a different style of technology transfer in Taiwan such that the technology exporter could not dominate, label, and even recognize its original technology.

The THSR core system is no exception in terms of HSR hybrids. As noted in chapter two, for example, the Spanish AVE was also known as a HSR hybrid of the TGV rolling stock and a German power supply system.¹³² In addition, the Korea Train Express (KTX) applied the TGV rolling stock technology, but the Koreans attempted to make it fit into their other self-developed HSR systems.¹³³ Both the AVE and KTX cases showed their intentions to transfer some critical HSR core technologies and then incorporate them with their local technologies. The KTX even plans to export its HSR technology in the future.

Like different tracks with different stories, every hybrid HSR core system has a different story as well. The THSR story might have been very different from the AVE and KTX to the point that, as Hood's quote at the beginning of this chapter states, the original HSR technology exporter Japan has been reluctant to say that the THSR or even its core system is another Shinkansen. This reaction is even more striking, since the THSR was the first instance of exported Shinkansen technology.

Since its core system has hybridized the Japanese, European and Taiwanese technology and practices, not even to say the THSR whole system. I have shown that the THSR civil work, track system and their specification-making were all contributed by internationally hybrid practices and collaboration. In this chapter, I have also demonstrated that the THSR was a

¹³² See more Kong.

¹³³ See the press release from the KTX's HSR rolling stock technology partner Alstom. Alstom, "Official Opening of the First High Speed Railway Line in Korea," Mar. 30, 2004. http://www.alstom.com/pr_corp_v2/2004/20533.EN.php?languageId=EN&dir=/pr_corp_v2/2004/&idRubriqueCourante=23132&cookie=true

product that inherited Taiwan's engineering tradition. The THSRC not only brought its past hybrid experiences but exploited the Taiwan Railways and the POHSR/BOHSR' hybrid strategies and resources into the project. In addition, I also showed that the THSRC would be unable to use these resources, experiences, strategies and practices without having equipped enough hybrid engineering expertise. Then, the THSRC could realize its core intention to design, build, operate and maintain the THSR independently.

CHAPTER 7

TAIWAN HSR PROJECT FACILITATED THE TAIWANESE/CHINESE IDENTITY

DISCOURSES COMPETITION:

POLITICAL/ENGINEERING DEPENDENCE, COMPETITION AND SUBJECTIVITY

After I demonstrated how the Taiwan HSR project has inherited and practiced the engineering tradition of hybridity in chapter five and six and showed how the Taiwanese and Chinese identity discourses displayed, struggled and later competed in the project in chapter four, I turn my attention to an examination of how this project has facilitated the emergence of Taiwanese discourse against the Chinese discourse in this chapter. This chapter mainly focuses on the identity politics embedded within the THSR project during stage four, from 1996 to the present. This stage was also the stage when the THSR project was under construction, as I have discussed in the last two chapters. I start this chapter by showing what could be perceived and detected in the Taiwan HSR project through a perspective of international and state politics. I argue that this project has brought international opportunities for both the Taiwanese and Chinese identity discourses to depend on. Later this project began to resemble a project manipulated by political regimes with two different political discourses.

Second, I argue that the engineering culture of hybridity embedded within the THSR project enabled the Taiwanese to search for their political subjectivity. It has a larger significance in ways of facilitating the project to stimulate and represent the discourse competition. Taiwan's engineering culture constructed its culture along with Japanese culture, Western culture and others. However, in the final section, the closer the project came to completion, the deeper it was trapped in domestic political struggles. The Taiwan HSR project represented less and less visionary and imaginary materials for identity discourse making as it approached realization.

7.1 THSR Project Politically Internationalizing and Position Taiwan (HSR)

*...while Germany is interested enough in the high-speed rail system to send top-level government officials to Taiwan to continue talks, negotiations with Japan have not progressed beyond basic items, which are: (1) bidding price, (2) safety, and (3) political considerations. Political considerations refer to the fact that money going into this project has to come from private sources, but we would like the Japanese government to give some indication of its support for the project.*¹—Teng-hui Lee

As noted in chapters five and six, while the Taiwan HSR project was planned, designed and constructed in an engineering format incorporating international collaboration from its inception to completion, either the POHSR/BOHSR or THSRC exerted significant effort to keep it independent from foreign engineering control from 1990 to 2007. On a parallel track, these nearly two decades were also exactly the time when the political discourse of the Taiwanese subjectivity and identity was in the process of being carefully fabricated.

The Taiwanese discourse has been significantly growing and gradually becoming able to compete with the Chinese discourse since the 1990s. I have shown this phenomenon in chapter four. However, their competition was not just based only on the strength of the Taiwanese and Chinese peoples on the island of Taiwan. Their competition, to a certain degree, has also depended on foreign involvement. In other words, different foreign power has been known to facilitate the construction/destruction of the Taiwanese/Chinese subjectivity/identity.

Taiwan is still today blocked from international politics mainly because its antagonistic and powerful neighbor the People's Republic of China has adamantly kept claiming that Taiwan has

¹ Teng-hui Lee, *The Road to Democracy: Taiwan's Pursuit of Identity*, 180.

been a historically inseparable part of it. Briefly, after it was expelled from the United Nations and most other international organizations in the 1960s and 1970s, the Republic of China/Taiwan has not been allowed to return or to participate in them in by the People's Republic of China, the U.S. and other major advanced countries.² Even the Chinese KMT regime was sometimes unwilling to return to international politics because of its insistence on the "One China" policy and its deep hatred of the Chinese Communist Party regime.³ Besides, its stubbornly imagined *de jure* stance toward Chinese identity discourse also prevented it from accepting the few chances of joining international politics under the name of Taiwan.⁴ As a result, to some degree, it seemed that an isolated Chinese population on Taiwan was being discursively shaped to concern the population on the mainland more than their local population and island before the 1990s. The isolated other was constructed to be the discursive self. The local Taiwanese were not a people existing under the authoritarian Chinese KMT governance/colonization.⁵

However, after he became president of the Republic of China, along with his new China policy of giving up the objective of reclaiming control over China by military force in 1991,⁶ Lee

² The Republic of China was replaced by the People's Republic of China and repelled from the United Nations in 1971. The U.S. terminated the diplomatic relationship with the Republic of China in 1978. See more Jean-Marie Henckaerts ed., *The International Status of Taiwan in the New World Order: Legal and Political Considerations* (London: Kluwer Law International Ltd., 1996).

³ See Hughes. Lang Kao, *The Evolution of Republic of China's Diplomatic Relations 1950~1972* (中華民國外交關係之演變: 一九五〇~一九七二) (Taipei: Wunan Publication, 1993). Lang Kao, *The Evolution of Republic of China's Diplomatic Relations 1972~1992* (中華民國外交關係之演變: 一九七二~一九九二) (Taipei: Wunan Publication, 1994). Dennis Van Vranken Hickey, *Foreign Policy Making in Taiwan: From Principle to Pragmatism* (NY: Routledge, 2007). Jacobs, "One China, Diplomatic Isolation and a Separate Taiwan." Jacobs, "Taiwan's Colonial History and Postcolonial Nationalism." Also see Clark.

⁴ *Ibid.*

⁵ See chapter 1 and Jacobs, "Taiwan's Colonial History and Postcolonial Nationalism."

⁶ On May 1, 1991, president Teng-hui Lee announced the end of the "Period of Communist Rebellion." This represented not only the Republic of China's recognition that the People's Republic of China essentially ruled mainland but also changed its reunion policy from an emphasis on military to peaceful means. See *United Daily*, "Temporary Provisions Terminated, Peaceful Approach to Union," Mar. 13, 1991. *United Daily*, "No Change Our Fundamental Policy, Only Union Policy Changed," May 2, 1991. *United Daily*, "Five Principles on Mainland China Policy; J. Song, KMT Secretary-General: Unity, Reality, Security, Reciprocity and Graduality," June 13, 1991. Also see "To deal with the threat posed by the Chinese Communist Party during the Chinese Civil War, the National Assembly adopted the *Temporary Provisions Effective During the Period of Communist Rebellion* in 1948. The *Temporary Provisions* suspended the Constitution and greatly expanded presidential powers for the duration of the emergency period. The *Temporary Provisions* allowed for the president and vice president of the Republic to be reelected indefinitely despite the two-term restriction prescribed in the Constitution. Following the end of martial

soon proposed a pragmatic diplomatic policy (務實外交) to the Taiwanese (or discursive Chinese) on the island.⁷ This policy attempted to announce the existence of Taiwan and its economic achievements to the world, while satisfying its domestic expectation to break through its long-standing diplomatic ostracism.⁸ Lee intended to bring the Republic of China an unprecedented set of relations with the People's Republic of China and the international community. On the one hand, after 1991, instead of viewing the People's Republic of China as a military rebellion force as it had since the 1930s, the Republic of China on Taiwan began to view it as a political entity that rules mainland China. In other words, the Republic of China abandoned its "One China" policy. As a result, the Republic of China then had to present itself as a different/original version of China in the world in the early 1990s.

The Taiwan HSR project was one of the few highly visible cases able to draw the international attention to come and learn about a different/original China (that is, the Republic of China) in the early 1990s, especially to those advanced and powerful foreign countries. As noted in chapters three, five and six, the project attracted cutting edge engineers from France, Germany, Italy, Japan and the U.S. Moreover, it also brought their important politicians,⁹ and even some new policies seeking closer and expanded bilateral development¹⁰ with Taiwan from 1991 to 1992. The Republic of China government welcomed this unexpected outcome very much.¹¹ It

law in the late 1980s, and with the reduction of tensions between the two sides of the Taiwan Strait, the National Assembly abolished the *Temporary Provisions* in 1991, with the aim of fully implementing constitutional democracy as well as fostering the healthy development of cross-strait relations. In that same year, President Lee Teng-hui announced the end of the Period of Communist Rebellion." See Government Information Office, *The Republic of China Yearbook 2008*, (Taipei: Government Information Office, 2008), chapter 4. See more detail at <http://www.gio.gov.tw/taiwan-website/5-gp/yearbook/ch4.html>

⁷ See footnote 1 and 2 this chapter. Also see Hui-Ying Chang (張慧英), *Super Diplomatist: Lee Teng-hui and His Pragmatic Diplomatic Policy (超級外交官: 李登輝和他的務實外交)* (Taipei: Commonwealth Publication, 1996).

⁸ *Ibid* and also see Tzu-Hwa Huang for more detail.

⁹ See *United Nightly*, "First Time, a French Minister Will Join the Republic of China-France Economic Cooperation Conference," Jan. 7, 1991. *Economic Daily*, "European Countries Playing Political Cards to Earn the 6-Year Plan," Jan. 12, 1991.

¹⁰ See *Economic Daily*, "Germany Decides to Establish a Federal Office of Forwign Trade Information in Taiwan," Jan. 7, 1991. *United Daily*, "French Minister of Industry: France-Republic of China Relations Should Develop in Low Profile," Jan. 11, 1991.

¹¹ See *United Nightly*, "French Minister of Industry Coming to Visit for Taiwan HSR Project, Ministry of Foreign

even intended later to gain some additional political profit by manipulating these countries competing for the Taiwan HSR project.¹² Although this positive international political response only lasted until shortly before the Taiwan HSR project was seriously trapped in financial controversy in 1993, this response helped the Republic of China government and its public to look at themselves and find their economic achievements might be able to earn them some political subjectivity. In his interview, for example, as Hau indicated, “Many and more foreigners, including the Germans, French, Dutch, Belgians, Americans and English, are coming here for our 6-Year Plan. This is explained by our economic strength. If we had no 90 billion USD of foreign exchange reserve..., we could not bring them here. Our pragmatic diplomatic policy is based on our economic strength. Due to our economic achievements and influences in the world, I feel we are not alone in the world.”¹³

Nevertheless, as Lee’s quote above, the Taiwan HSR project came to play a more clear and significant role in internationalizing the subjectivity of Taiwan after the mid 1990s. Among other countries, as he indicated, the project should especially take Japan into account in terms of the political interest that might benefit Taiwan the most. Lee mentioned this political concern in chapter seven, titled “What Taiwan, the U.S. and Japan Could Contribute to Asia?”, of his book *With the People Always in My Heart*. He basically argued how Taiwan, the U.S. and Japan could work together in order to bring them the most benefits and to prevent the People’s Republic of China from jeopardizing Asia’s security. Briefly, on the role of Taiwan in Asia, Lee advocated positioning Taiwan’s international status as “the Republic of China on Taiwan,” by

Affairs: Surprised and Pleased,” Dec. 17, 1990.

¹² See *United Daily*, “After French Minister, Germans Coming for Taiwan HSR, Ministry of Foreign Affairs: German Political Action Matters,” Jan. 29, 1991. *Economic Daily*, “Benz Group Pushing German Politicians Visit Taiwan for Taiwan HSR Project,” Feb. 25, 1991. *United Nightly*, “Americans Concern French Activities for the 6-Year Plan,” Mar. 13, 1991. *United Daily*, “Italian Minister of Public Works Coming after French,” Apr. 4, 1991. *Economic Daily*, “Why Japanese Not Like French Approaching to Us,” Apr. 21, 1991. *Economic Daily*, “French Teaches Japanese a Lesson,” May 7, 1991.

¹³ Hau, 368~9.

which Taiwan would acquire state subjectivity and independent sovereignty from China.¹⁴ In other words, Taiwan should be accepted as a substantial actor in the Asia Pacific area but not be internalized into Chinese domestic politics. On the roles of the U.S. and Japan, among others, he urged them not to follow the People's Republic of China's claim that the cross-strait relationship between China and Taiwan was only a domestic issue. They should make serious efforts to maintain and support Taiwan's international status in order to check the People's Republic of China and thus benefit their own and Taiwan's interests. In short, Lee's "Republic of China on Taiwan" policy not only intended to keep Taiwan from the People's Republic of China's control in terms of political internalization but also attempted to conform to the U.S. and Japan's international interests.¹⁵

As a result, Lee urged the Japanese government to show a more proactive and supportive attitude to the Taiwan HSR project since the project was a significant indicator at the time. He characterized the project as one of the few significant internationalizing ways to place Taiwan as a subjective and independent actor among China, the U.S. and Japan. Lee briefly made a political extrapolation that, "All three countries (Japan, U.S. and Taiwan) would gain from active American and Japanese investment growing hand in hand with technological development in Taiwan. At the same time, they would forge closer and deeper relationships."¹⁶ However, as Lee realized, whether the project could play this given political role well depended significantly on Japan's willingness.

¹⁴ See *Times*, "Strait Talk: The Full Interview," Feb. 16, 2004. In this interview, president Shui-bian Chen indicated the inheritance and development from Lee to his policies that "A simple way to describe the status quo of Taiwan is this: First the Republic of China was on mainland China, then the Republic of China came to Taiwan, then the Republic of China was on Taiwan, and now the Republic of China is Taiwan." See more <http://www.time.com/time/world/article/0,8599,591376-2,00.html>

¹⁵ See Teng-hui Lee, *With the People Always in My Heart*, chapter 7. Teng-hui Lee, *The Road to Democracy: Taiwan's Pursuit of Identity*, chapter 6. Teng-hui Lee and Mineo Nakajima, *Asia's Intellectual Strategies*, section 2. Teng-hui Lee and Yoshinori Kobayashi, *Teng-hui Lee School's Wisdom*, chapter 5.

¹⁶ Teng-hui Lee, *The Road to Democracy: Taiwan's Pursuit of Identity*, 181.

Like its engineering practices, the political discourse given and embedded within the Taiwan HSR project showed that the majority of the people on the island of Taiwan was facilitated to reinvestigate their tradition/past, review their specialty/identity and build their engineering/indigenized community by some international collaboration. The Taiwan HSR project was not only entitled to recall and build the Taiwanese engineering tradition and culture, but also helped establish their political subjectivity and people. In short, through the Taiwan HSR project, the Taiwanese engineers and people inherited and struggled over a similar trajectory from Taiwan's dependence on foreign technological/political power to its competition with them and then to its struggles for subjectivity against them.

7.2 BOT Contract Competition, THSRC Core System Switch Controversy, and Implicit Discourse Politics

After opening the bid forms, it was recognized that the level of government investment required by

—Taiwan High Speed Rail Consortium (THSRC) is -105.702 billion NT dollars (-3.69 billion USD).¹⁷

—China Development Corporation (China Development) is 149.5 billion NT dollars (5.22 billion USD).¹⁸

By “-105.702 billion NT dollars (mainly the cost to the government for land expropriation)¹⁹,” THSRC added that they intend to pay back the government grant of 105.702 billion NT dollars using 10% of the annual profits made during the 30 year commercial operation period...all

¹⁷ The number was slightly modified to 108.0 billion NTD (3.77 billion USD) in the HSR BOT contract. See BOHSR, “Taiwan South-North High Speed Rail Construction and Operation Contract,” §9.1. The annual average exchange rate was 1 USD equaled to 28.6618 NTD in the year of 1997.

¹⁸ *Ibid.*

¹⁹ See Nuan-Hsuan Ho, “Taiwan HSR Will Create New Phases on City and Town Development,” in *Taiwan Year Book 2005* (Taipei: CNA News, 2005). See more at <http://www7.www.gov.tw/todaytw/2005/TWtaiwan/ch10/2-10-2-0.html>

(Comprehensive Selection and Evaluation) committee members unanimously agreed that THSRC is the Best Applicant for the HSR project, and China Development is the Second Best Applicant for the same.²⁰

After the *Statutes for Encouragement of Transportation Infrastructure Projects* came into force at the end of 1994, the POHSR began to enact several relevant regulations. In addition, it invited financial, legal and general engineering consultant services, planned land acquisition programs, and conducted other preparation work of BOT tender etc in 1995 and 1996.²¹ All of these works aimed to appeal to Taiwanese private investment on the Taiwan HSR project. In addition, the POHSR also looked for some investment and other funding sources outside Taiwan in order to help the potential Taiwanese BOT tenders satisfy the project's enormous financial demand.²²

The POHSR announced the invitation to tender for the HSR Private Investment (BOT) Project in October 1996 and the deadline for application was in January 1997. Although the POHSR set up the general preparation work well, its Director General Chin-Lung Liao expressed worries about whether the BOT program could attract earnest private investment in the Taiwan

²⁰ BOHSR, "Selection and Evaluation of HSR Private Investment Applications," *HSR Newsletter* 1: 20 (1997): 4~5.

²¹ See POHSR, "Progress on the Enactment of the Encouragement Statute's By-laws," *High Speed Rail Newsletter* 1: 1 (1995): 2. POHSR, "Land Acquisition Seminars Moving Forward HSR Project," *High Speed Rail Newsletter* 1: 1 (1995): 3. POHSR, "Progress on the Preparation of Build-Operate-Transfer Tender," *High Speed Rail Newsletter* 1: 1 (1995): 4. POHSR, "Tendering of Financial Consultant Services to the High Speed Rail Project," *High Speed Rail Newsletter* 1: 1 (1995): 5. POHSR, "Exploring New Incentives for Land Owners Along the HSR Route," *High Speed Rail Newsletter* 1: 1 (1995): 7. POHSR, "Innovative Land Development Program Under Study," *High Speed Rail Newsletter* 1: 1 (1995): 8. POHSR, "Preparation of BOT Tender for HSR Project," *High Speed Rail Newsletter* 1: 2 (1995): 1. POHSR, "Promotion of HSR Privatization Program," *High Speed Rail Newsletter* 1: 2 (1995): 2. POHSR, "General Engineering Consultant Tender," *High Speed Rail Newsletter* 1: 2 (1995): 3. POHSR, "Invitation to Tender on 'Legal Consultant Services' Announced," *High Speed Rail Newsletter* 1: 4 (1996): 6. POHSR, "POHSR Briefs Japanese Companies," *High Speed Rail Newsletter* 1: 7 (1996): 1.

²² See POHSR, "Promotion of HSR Privatization Program." POHSR, "Exploring the Methods and Obstacles of Domestic Funding for the HSR Construction," *High Speed Rail Newsletter* 1: 2 (1995): 5. POHSR, "Director General Holds Seminars in Europe," *High Speed Rail Newsletter* 1: 3 (1995): 1. POHSR, "POHSR Delegations Visit France, Germany and Japan," *High Speed Rail Newsletter* 1: 9 (1996): 4. POHSR, "Presentation on HSR Project Held in Tokyo," *High Speed Rail Newsletter* 1: 10 (1996): 1. POHSR, "POHSR Delegation Visits Investors, Bankers in Europe," *High Speed Rail Newsletter* 1: 10 (1996): 3.

HSR project.²³ It turned out that there were two consortia, the China Development and THSRC, that submitted proposals to introduce Japan's Shinkansen system and France's TGV system to Taiwan respectively.²⁴ Chin-Lung Liao was surprised and delighted to see that some renowned local enterprises showed an interest and integrated together coming to bid for the project.²⁵

This tender development also surprised three foreign HSR consortia led by the French Gec-Alstom, German Benz and Japanese Mitsui & Co., LTD, who kept hoping the Taiwanese government would change its BOT policy. As noted, they were suspicious about whether the Taiwan HSR project would be successful under private investment leadership.²⁶ In addition, they also expected the government to take full responsibility for the Taiwan HSR building work, by which the project would turn back to a procurement model. Compared with the BOT model, the three foreign HSR consortia thus could make more profits, invest less money and confront fewer risks by simply selling their HSR systems to the Taiwanese government.²⁷ However, obviously, their expectation was not realized. After the two consortia led by Gec-Alstom and Benz merged and organized a joint group called the Eurotrain,²⁸ the THSRC chose to work with it and intended to introduce the TGV system with some German ICE technology to Taiwan. The THSRC planned to apply the ICE locomotives to pull and push the TGV trains.²⁹ On the other side, China Development decided to choose the Japanese system and proposed to build another Shinkansen line in Taiwan. To some degree, that both China Development and THSRC jumped

²³ See *Economic Daily*, "Announcing to Invite Private Investment on HSR Project by the End of October," Oct. 12, 1996.

²⁴ See BOHSR, "Qualification Examination for HSR Private Investment (BOT) Project Completed: Qualified Applicants Invited to Discuss Follow-up Work Plan," *High Speed Rail Newsletter* 1: 13 (1997): 3.

²⁵ See *Economic Daily*, "Euro and Jpn Competing For HSR Project: THSRC and China Development Running for 441.9 Billion NTD Business," Jan. 16, 1997.

²⁶ See *Economic Daily*, "Three Foreign HSR Consortia Suspicious to BOT Bid Program," Oct. 1, 1996.

²⁷ *Ibid.*

²⁸ See *Economic Daily*, "Foreign HSR Consortia Actively Conducting Integration for Taiwan HSR Project," Dec. 22, 1996.

²⁹ *Ibid.* Also see *Economic Daily*, "China Development Taking on THSRC: Questioning THSRC French-German Hybrid Rolling Stock," Sep. 25, 1997. *Economic Daily*, "Taiwan Star Tested," May 4, 1998. *United Daily*, "German Locomotives Pull and Push French Trains: THSR Rolling Stock Tested Successfully," May 5, 1998.

into the BOT project represented a different stage of technology transfer from dependence, competition to subjectivity.

Denomination was political. Both China Development and THSRC chose titles that would be the most recognized for the majority of the Taiwanese/Chinese people. While the former adopted the term “China” in front of its name, the latter used “Taiwan” as the leading term in its full name. Literally, China Development’s Chinese name was the “Chinese High Speed Rail Consortium (CHSRC)” in the case of the Taiwan HSR BOT project. China Development itself was the financial company that led several other local and Japanese conglomerates to organize the CHSRC against the THSRC. During the period from 1996 to 1997, China Development’s chairman, Tai-ying Liu (劉泰英), was also the chairman of the KMT Business Management Committee (國民黨投資事業管理委員會).³⁰ Although it structurally resembled a usual private corporation in Taiwan, China Development was known as a part of the KMT-run business. Among other banking and investment businesses, it also coordinated with the Lee government to solidify the relationship among local politicians, businessmen and the KMT regime.³¹ In addition, China Development also conducted some overseas investment along with the Lee government’s foreign policy.³² Basically, China Development signaled its connection to the KMT regime and Chinese population on the island of Taiwan.

Furthermore, as noted at the beginning of chapter four, the THSRC mainly consisted of five local conglomerates and Gec-Alstom and Siemens. These five local conglomerates’ chairmen were characterized as the younger generation of local entrepreneurs, mostly native

³⁰ See *Economic Daily*, “China Development Leads to Run for Taiwan HSR Project,” Jan. 15, 1997. *Economic Daily*, “Euro and Jpn Competing For HSR Project: THSRC and China Development Running for 441.9 Billion NTD Business,” Jan. 16, 1997.

³¹ See Shih-Meng S. Chen (陳師孟) *et al*, *Disintegrating KMT-State Capitalism: A Closer Look at Privatizing Taiwan’s State—and Party—Owned Enterprises* (Taipei: Taiwan Society, 1991). Kanlin Hsu (許甘霖), “The Logic of Political Domination or the Logic of Market?: Rethinking ‘Party-Owned Enterprise’” *Taiwan: A Radical Quarterly in Social Studies* 28 (1997): 175–208. Ming-Tong Chen.

³² *Ibid*. Also see Scott L. Kastner, *Political Conflict and Economic Interdependence across the Taiwan Strait and Beyond* (Stanford, CA: Stanford University Press, 2009), chapter 4.

Taiwanese or at least Taiwan-born.³³ As one of their chairmen, Nita Ing was proposed by the other chairmen to lead and represent the THSRC. She is a Taiwan-born mainlander, a graduate of the University of California at Los Angeles, an outspoken and unusual woman in terms of marriage, a chairwoman of one of the largest civil construction companies in Taiwan, and a strong DPP supporter.³⁴ All these characteristics, among others, make Ing a popular and controversial entrepreneur, woman and mother, and opinion leader in Taiwan. Basically, the THSRC signaled its inclination to the DPP and Taiwanese population on the island of Taiwan through Ing's appointment.

Both China Development and THSRC passed the first stage review of the qualification examination held by the BOHSR and MOTC's Selection Committee in January 1997. Then they soon prepared their follow-up work with the BOHSR from March to June in order to submit their detailed proposals for the second stage review of the substantial examination by the end of August. The Committee reviewed their proposals including the project summary, construction plan, operation plan, land use plan, station area development plan, financial plan, asset transfer plan, forming of project company and alternative operation plan before the completion of the Nankang (南港) extension project. Finally the Committee reached a consensus that THSRC was the Best applicant and China Development was the Second Best applicant after the second stage review in September 1997.³⁵

The main reason that THSRC earned the Taiwan HSR BOT contract was, as noted in the opening paragraph, that it offered an undeniably tempting and aggressive financial plan to the government. It not only needed no government subsidy, but attempted to pay back the

³³ See *Economic Daily*, "Two Consortia Compete for Taiwan HSR Project: Who Allows Government Spend Less Is the Key," Sep. 1, 1997. *Economic Daily*, "HSR Project Draws New Business Generation," Sep. 17, 1997.

³⁴ See Chao-Yi Wu. Also see Su-Yu Chuang (莊素玉), "Ing: Wants to Prove Taiwan Society's Capability," *Commonwealth Magazine* 198 (1997): 52~8. After two divorces, Ing encountered another romance and has raised two daughters.

³⁵ See BOHSR, "Selection and Evaluation of HSR Private Investment Applications."

contributed government investment of about 3.69 billion USD with 10% of its annual profit during the 30-year concession period. By contrast, the China Development bid called for a 5.22 billion USD subsidy from the government. In addition, THSRC pledged to complete the building work by July 2003, compared to a 2005 date in the other proposal.³⁶ As a result, mainly because of the drastic financial difference between the bids, the Selection Committee decided to go with the THSRC bid. THSRC won the Taiwan HSR BOT contract by saving the government nearly 9 billion USD in comparison with China Development's proposal. The Taiwanese public was positive and delighted to see this result.³⁷ It welcomed not only the benefits that a competitive market brought to them, but also the defeat the abnormal political-capital KMT confronted. Their financial proposals are summarized in Chart 7.1.

It could be a possible to conjecture that Lee might favor the THSRC because both of them seemed to share a similar Taiwanese discourse. However, there was no clear indication to show that the THSRC's victory was attributed to any political factor. The significant gap between THSRC's and China Development's proposals hardly left room for political involvement. Besides, China Development was affiliated with the KMT, which was chaired by Lee at the time. Its chairman Tai-ying Liu was even known to be Lee's personal friend. Even if he were to implicitly express his preference to either camp, Lee might confront serious political pressure and attacks from the aggressive media well nurtured by Taiwan's democratization in the 1990s. In early 2009, the Taiwan ombudsman agency, the Control Yuan (監察院), started investigating the HSR BOT policy and its bidding and implementation process. Its investigation report was released at the end of the same year indicating no political involvement from Lee or other

³⁶ See *Economic Daily*, "THSRC Upper Hand on Financial Plan," Sep. 23, 1997. *United Daily*, "HSR Project Changing Taiwan Business," Sep. 25, 1997. *United Daily*, "THSRC: Finish By 2003, Challenging but Confident," Sep. 26, 1997. *United Daily*, "HSR BOT Contract Signed: Open to Traffic by 2003," July 24, 1998.

³⁷ See *United Daily*, "Editorial Colum: HSR Project Review," Sep. 27, 1997.

politicians.³⁸ Nevertheless, Lee still allegedly exerted some political influence on the HSR BOT project after the THSRC won the contract.

Chart 7.1 China Development and THSRC Financial Investment Proposal (billions NTD)
(public domain)

Construction Cost Estimate: 513.3	THSRC Proposal	Max. Private Responsible Part: 407.6	Stock Inv't 103.8; 27% (5 original members: 52.93; 51%)	Self-Liquidating Amount 383.3; 74.8%	Self-Liquidating Amount 325.5; 52.0%	Stock Inv't 100.2	Max. Private Responsible Part: 519.8	China Development Proposal	Construction Cost Estimate: 625.5
			Loan 280.0; 73%						
		Gov't Inv't Conducted by Private 23.8		Non Self-Liquidating Amount: 300.0; 48.0%	Gov't Inv't Conducted by Private 194.3				
		Gov't Commitment 105.7	Gov't Inv't 105.7	Non Self-Liquidating Amount: 129.5; 25.2%	Gov't Inv't 105.7	Gov't Commitment 105.7			

* The annual average exchange rate was 1 USD equaled to 28.6618 NTD in the year of 1997.

Source: the Control Yuan, *Review on the Effect of the Taiwan HSR BOT Policy Strategy and Implementation* (Taipei, Taiwan: Control Yuan, 2009), 15.

³⁸ See Control Yuan, *Review on the Effect of the Taiwan HSR BOT Policy Strategy and Implementation*. Download the report at Control Yuan website:
http://www.cy.gov.tw/ourpaper.asp?AP_Code=eDoc&Func_Code=t01&case_id=098000582

As noted, Lee wanted the Taiwan HSR to be another Shinkansen line. The more interesting thing was that he explicitly expressed this preference in his book published in 1999, right after the THSRC won and signed the BOT contract with the MOTC in 1997 and 1998 respectively.³⁹ Although the contract showed no strict rule on which core system it would adopt, the THSRC had been consistently expressing an intention to introduce the TGV core system with some ICE technology to Taiwan. As noted in chapter four, the BOHSR aimed to allow the THSRC to make its construction plan with as much as flexibility as possible, including its choice on the core system.⁴⁰ In addition, although it cooperated with Eurotrain to bid for the BOT contract, the THSRC signed no contract with Eurotrain during the BOT contract bidding and negotiation period. Therefore, the THSRC was still able to switch its core system plan, if this would bring it more profits or advantages. However, it was unlikely to expect that the THSRC would change its core system adoption policy at the time especially since it had worked extensively with Eurotrain in 1998.

Nevertheless, it turned out that the THSRC announced it would negotiate its core system contract with the Japanese Taiwan Shinkansen Corporation (Taiwan Shinkansen) prior to Eurotrain in December 1999.⁴¹ After nearly one year, the THSRC signed the core system contract with Taiwan Shinkansen in Tokyo in December 2000. This Shinkansen system cost the THSRC around 95 billion NTD (3.04 billion USD).⁴² Later this core system change also gained the MOTC and BOHSR's agreement in June 2001.⁴³ Actually, before the THSRC negotiated

³⁹ See BOHSR, "Information on the Contract to Build, Operate, and Transfer the Taiwan North-South High Speed Rail (HSR)."

⁴⁰ Also "THSRC, a private company with concession right, is responsible for over all construction of the HSR project, including the selection of mechanical & electrical systems. All systems chosen by THSRC are required to meet the standards of functions, quality, safety, etc. specified in the contract and be approved by MOTC." BOHSR, "Selection of HSR Mechanical & Electrical Systems," *HSR Newsletter* 4: 42 (1999): 7.

⁴¹ See BOHSR, "Progress of the Taiwan HSR Project," *HSR Newsletter* 4: 47 (2000): 1~2.

⁴² See BOHSR, "Progress of Taiwan HSR Project," *HSR Newsletter* 5: 59 (2000): 1~2. Also see BOHSR, "THSRC Signed Memorandum of Adopting Japanese Shinkansen System," *HSR Newsletter* 5: 53 (2000): 1. Control Yuan, 57~8. The annual average exchange rate was 1 USD equaled to 31.2252 NTD in the year of 1997.

⁴³ According to Article 5.1.2 in "Application Instruction Supplement (I)," any change of the core system is subject to the consent of the MOTC and BOHSR. BOHSR, "Application for a Change of HSR Core System," *HSR Newsletter*

with the TSC, Eurotrain was very confident that they would obtain the THSRC's core system contract since it had worked with the THSRC from the very beginning. As noted, it had even started conducting some system integration work and tested the TGV-ICE hybrid rolling stock called Taiwan Star in Germany in 1998.⁴⁴ The THSRC's decision made Eurotrain very surprised, confused and disappointed. It later sued the THSRC and asked for compensation of 800 million USD.⁴⁵ Siemens' president went to see Lee and his premier Vincent C. Siew (蕭萬長) of the Executive Yuan, but gained no positive response.⁴⁶ The French, German and British representatives in Taiwan also expressed their deep concern over the core system's bidding process to the MOTC.⁴⁷ Both the Taiwanese government and THSRC displayed an adamant altitude toward Eurotrain, those European business leaders, and their governmental representatives.

On the other hand, to some degree, the Japanese were also surprised in the beginning that the THSRC did seriously expect them to bid for its core system contract. When the THSRC announced invitations for core system applicants in June 1999, the Japanese Taiwan Shinkansen hesitated to join the bidding since they understood that the THSRC had worked with Eurotrain since 1996. However, they were highly encouraged by their politicians and the BOHSR to compete with Eurotrain.⁴⁸ Politics seemed to have played an invisible role here.

Some information indicates that Lee's political preference might have interfered with THSRC's decision to switch.⁴⁹ Some even claimed that Lee's intervention aimed to earn himself

6: 61 (2001): 7. Also see BOHSR, "MOTC Consented to Japanese Shinkansen System as the Reference System for Core System," *HSR Newsletter* 6: 65 (2001): 4.

⁴⁴ See *Economic Daily*, "Taiwan Star Tested," May 4, 1998.

⁴⁵ See *United Nightly*, "Eurotrain Might Ask for Compensation," Dec. 29, 1999. *United Daily*, "THSRC Negotiates with Eurotrain for Compensation," Apr. 2, 2002.

⁴⁶ See *Economic Daily*, "Lee: No Comment on HSR Business Activity," Jan. 15, 2000.

⁴⁷ See *United Daily*, "French, German and British Representatives in Taiwan Concern Core System Bidding," Jan. 26, 2000.

⁴⁸ An interview with Chin-Lung Liao.

⁴⁹ See *United Daily*, "Japanese Press Reports THSR Expected to Adopt Shinkansen before Result Coming Out," Dec. 18, 1999. *United Daily*, "Politics Mattered? Some Recent Events with the Japanese Politicians," Dec. 29, 1999. *United Daily*, "Something Needs to be Checked," Dec. 30, 1999. *United Daily*, "DPP Legislator Chen Chao-Nan

a formal visit to Japan after he left office as president in 2000.⁵⁰ They were not unconvincing. Lee did invite Ing and Tai-ying Liu to the president's office soon after the THSRC signed the HSR BOT contract with the MOTC in September 1999. He also had meetings with some important Japanese politicians and press in which he explicitly expressed his favor for the Shinkansen technology before the THSRC made its decision.⁵¹ In addition, Ing even went to visit Japan and take a Shinkansen ride in May. Allegedly, the THSRC was considering switching its core system to the Shinkansen.⁵² However, no specific and confirmed information was released.⁵³ Lee and Ing's conversation in the president's office remained a mystery. Nevertheless, as noted above, Lee's book and some of his Japanese interviews in the second half of 1999 not only clearly showed his intention to create a closer political partnership with Japan, but also indicated that Lee voted strongly for the Shinkansen core system for the Taiwan HSR project. It would not be a wild conjecture to suggest that Lee might have produced some critical influence on the THSRC's decision to switch the core system, especially given the background that the THSRC continued planning to install the Euro HSR core system before mid-1999.

Due to business confidentiality, the THSRC and Ing gave no detailed reason to explain why they decided to adopt the Shinkansen core system. Ing claimed that Eurotrain was too confident to lose their contract. In addition, she denied their decision making process included any political concerns. At the same time, the Japanese Ministry of Foreign Affairs also stated that the THSRC's decision to switch to the Shinkansen was purely a business choice. The Japanese government had no intention to develop a closer relationship with Taiwan because of this decision to switch. However, Ing did point out that price was the key factor, but she stopped

(陳昭南): Euro-Jpn Battle Fire Spreading," May 9, 2001.

⁵⁰ See Hood, chapter 7. Also see *United Daily*, "Japan Economic Times: Lee's Japan Visit Raises Controversy in Liberal Democratic Party (日本自民黨)," Mar. 27, 2000. *United Daily*, "Iwasato Masao (Lee's Japanese name during the Japanese colonial period; 岩里政男) in Japan," Dec. 29, 2004.

⁵¹ See footnote 49.

⁵² See *United Daily*, "Final Count Down On Core System Tender," May 26, 1999.

⁵³ See *Central News Agency*, "THSRC No Comments on Lee-Ing Meeting," Aug. 11, 1999.

there.⁵⁴ No confirmed information indicated how much different the Japanese and Eurotrain offers were to the THSRC. Allegedly, the price gap might have reached 10 billion NTD (320.25 million USD).⁵⁵ Some of my interviewees and other information even claimed that Eurotrain asked for 150 billion NTD (4.80 billion USD) for the core system at the time while the Japanese TSC, as noted, only asked for 95 billion NTD (3.04 billion USD).⁵⁶ However, the THSRC later was required by the International Chamber of Commerce to compensate Eurotrain 73.04 million USD in March 2004, but this number was far below the 800 million USD that Eurotrain requested.⁵⁷ Moreover, the THSRC renegotiated with Eurotrain later and both agreed to settle this issue for only 65 million USD at the end of 2004.⁵⁸

The THSRC's decision to switch the THSR core system from the TGV-ICE hybrid to the Shinkansen system signaled that the Taiwan HSR project reached a symbolic peak as well as an end in terms of international politics. I have shown that the project had been well exploited to gain international political objectives in different periods. First, it was a part of rebuilding the orthodox Chinese discourse against the Chinese Communist Party and the People's Republic of China. The KMT government renamed the "Taiwan Area 6 (or 4)-Year Development Plan" that had been used for years to the "6-Year *National* Development Plan."⁵⁹ As one of the largest projects in the 6-Year Plan, the Taiwan HSR project was set up to build a prosperous and developed Republic of China in contrast to the People's Republic of China. Second, the Taiwan HSR project later began to facilitate the construction of the Taiwanese discourse from "the

⁵⁴ See *United Daily*, "Ing: Eurotrain too Confident to Lose," Jan. 7, 2000.

⁵⁵ See *Economic Daily*, "Eurotrain Wins Superficially," Mar. 16, 2004.

⁵⁶ Interviews with the THSRC engineers. Also see *Economic Daily*, "THSR Reliable? Japanese Rolling Stock, French Conductors and British Verification & Validation," Dec. 25, 2006.

⁵⁷ See Control Yuan, 61~3. *Economic Daily*, "THSRC Required to Compensate Eurotrain 24 NTD," Mar. 16, 2004. *United Daily*, "Business Negotiation 3 More Years: THSRC Required to Compensate Eurotrain 24 NTD," Mar. 16, 2004.

⁵⁸ See Control Yuan, 61~63. *Economic Daily*, "4 Years Later, THSRC Settled Down with Eurotrain with 6.50 Million USD," Nov. 27, 2004.

⁵⁹ See Hsi-Junn Kao (高希均) "6-Year Plan, a Necessary Surgery," *Economic Daily*, Feb. 10, 1991.

Republic of China on Taiwan” to the “special state-to-state relations between Taiwan and China.” It offered a precious chance for the majority of the people on Taiwan to regard their island and reframe their political relations. Instead of the discursively imaginary community with the Chinese identity and the mainland, the “one-day access society” created by the Taiwan HSR has become most of the people’s imagined community. In addition, I demonstrated that the Taiwanese discourse needed international power to achieve it. The HSR project thus was not only projected to draw foreign attention to Taiwan, but also to help Taiwan gain a subjective position in terms of international politics among the U.S., the People’s Republic of China and Japan. However, while it was approaching the construction stage, the project left fewer and fewer opportunities to offer sustenance for political discourse making. The project, nevertheless, soon became swamped in domestic politics.

7.3 The THSR Project Fading into Domestic Party Politics

After the best and second best applicants were selected by the MOTC in September 1997, both the THSRC and China Development began a more-detailed BOT contract negotiation with the BOHSR. The negotiation of the contract, including a “Construction and Operation Agreement” and a “Station Area Development Agreement,” was completed and then granted by the Executive Yuan conditionally in February 1998.⁶⁰ Among other things, the Executive Yuan suggested the “BOHSR should urge the THSRC to form a Concession Company as soon as possible in order to facilitate its financing application and arrangement.”⁶¹ Finally, the THSRC officially signed the HSR BOT contract with the MOTC in July, which also meant that China Development completely lost any chances to win the HSR contract.⁶² Moreover, they also signed a couple of memoranda, i.e., the “Memorandum of Items Responsible by the Government

⁶⁰ See BOHSR, “HSR BOT Contract Negotiation Completed,” *HSR Newsletter* 1: 23 (1998): 9. BOHSR, “Executive Yuan Gives Consent to HSR C&O Agreement,” *HSR Newsletter* 1: 25 (1998): 5.

⁶¹ BOHSR, “Executive Yuan Gives Consent to HSR C&O Agreement.”

⁶² See BOHSR, “Contract Officially Signed Between the Ministry of Transportation and Communications and the Taiwan High Speed Rail Company,” *HSR Newsletter* 3: 30 (1998): 1~2.

(MIRG)” and the “Memorandum of Contract Execution (MCE).”⁶³ Instead of the two agreements, it was the two memoranda that raised debates as well as controversies before the THSRC and MOTC agreed to sign it. In addition, the THSRC’s financing arrangement later caused serious domestic political struggles for years.

The *MCE* focused on the elaboration and clarification of contents of articles and clauses and the appendices. Both parties agreed that a negotiation agreement on points brought by the Taiwan High Speed Rail Company will be achieved before October 1 1998 so that the contract can be smoothly executed. The *MIRG* focused on the confirmation of the various coordination plans responsible by the Government and the corresponding scheduling such that the whole project can be executed on scheduled...In the event that these work items could not be completed as scheduled and are considered to be hindrance to the progress of construction, the Company then have the right to terminate the contract at the date on or before August 1 1999. To such effect the Government will have to return the performance bond and pay in addition an indemnity in cash to the Company for physical expenses incurred to the Company for the period between the date the contract was signed to the date the contract is terminated...⁶⁴

The MCE and MIRG were the documents that the THSRC wanted the MOTC to include as a part in the HSR BOT contract one month before they signed.⁶⁵ Although the MOTC claimed

⁶³ *Ibid.* “Since MOTC and THSRC signed the memorandum (MIRG) on July 23 1998, with the help of all government authorities concerned, the 28 items of commitments were recognized and approved finally.” BOHSR, “Progress of ‘Items Committed by the Government’ of HSR Private Sector Investment Project (Conclusion),” *HSR Newsletter* 4:42 (1999): 1~2.

⁶⁴ *Ibid.*

⁶⁵ See *United Daily*, “HSR BOT Contract Negotiation Troubling: THSRC Might Refuse and China Development Might Substitute,” July 2, 1998.

the main content of the two memoranda had been written in the two agreements, the THSRC still wanted them to be separate and stated more specifically and clearly, especially regarding their rights and obligations.⁶⁶ For example, one of the most important issues, as the quotation above indicates, was that the THSRC wanted the two memoranda to offer them the condition that the THSRC could terminate the contract and ask the government for compensation if it could not realize its commitments to the THSRC. In addition, it also wanted the MOTC to make substantial permits that needed signoffs from multiple government agencies.⁶⁷ In general, while the MOTC was complaining that the THSRC was too demanding, the latter was not satisfied with the former's hesitations and passiveness. Ing even commented that the government itself was the biggest risk to the success of the HSR BOT project.⁶⁸

As a result, the THSRC and MOTC could not reach a consensus by the date of July 1 1998 when they were supposed to sign the contract, although their contract signing ceremony was still prepared and even held as scheduled. All invited guests in the ceremony were surprised and shocked to hear Ing and the minister of the MOTC announced that their "marriage" had temporary failed.⁶⁹ The MOTC even allegedly intended to renegotiate the HSR BOT contract with the Second Best Applicant, China Development.⁷⁰ However, the MOTC still officially recognized the THSRC as the Best Applicant and continued negotiations with the THSRC. Finally they signed the contract a few weeks later on July 23 1998 and China Development was dismissed at the same time. One year later, all twenty-eight items in the MIRG committed to by the government of the HSR BOT project were completed.⁷¹

⁶⁶ *Ibid*; *United Daily*, "What's Wrong the Contract Signing," July 3, 1998.

⁶⁷ See BOHSR, "A Report to President Lee: Progress of HSR C&O Agreement," *HSR Newsletter* 1: 26 (1998): 1.

⁶⁸ See *Economic Daily*, "HSR Special Report 1/3," Jan. 27, 2003.

⁶⁹ See *United Daily*, "HSR BOT Contract Negotiation Troubling: THSRC Might Refuse and China Development Might Substitute." *Economic Daily*, "HSR Marriage Failed Due to Discontent with Each Other's Offering," July 2, 1998. *United Daily*, "Ing Interview: Government Intervention and Threat in Negotiation Process," July 3, 1998.

⁷⁰ See *United Daily*, "China Development Manage General: We Do not Exclude to Join," July 3, 1998.

⁷¹ See BOHSR, "All the 'Items Committed by Government' of the HSR Project Completed," *HSR Newsletter* 4: 40 (1999): 1. BOHSR, "Progress of 'Items Committed by the Government' of HSR Private Sector Investment Project

On a parallel track, financial negotiations had been proceeding during this time. The THSRC proposal in 1997, as noted, asked for no government subsidy. However, some bank advice to the government in evaluating its proposal had raised a number of questions about financing the project in general, including the huge amount of funds required, regulatory limits on the percentage of a bank's loans that could go to one borrower. In addition, the value of the equity that the THSRC promised to invest was greater than the members' total equity for their entire companies. Meanwhile, the 1997 Asian financial crisis badly damaged Asian capital markets. The Taiwan Ministry of Finance insisted on maintaining a conservative policy on domestic business loans.⁷² Finally, the THSRC's uncertainty of whether to install the core system from the Europeans or the Japanese as noted above made it more difficult to arrange project financing from those potential European or Japanese HSR manufacturers and other financial institutes. President Lee, through a meeting with the Executive Yuan, Economic Council, the Ministry of Finance and the MOTC etc., made it clear that the Taiwan HSR project should begin construction work soon, and the BOHSR and MOTC should work with the Ministry of Finance to help the THSRC deal with its financial arrangements.⁷³

Eventually, the MOTC, THSRC and Syndicated Banks signed a tri-party consensus document in August 1999. Shortly, the THSRC and Syndicated Banks were guaranteed of enduring little financial risks based on the government's endorsement.⁷⁴ However, this endorsement created a series of critics and controversies in terms of financial planning for years thereafter. The loan agreement with the Syndicate Banks was settled in February

(Conclusion).”

⁷² See *United Daily*, “BOHSR: Loaning Progress Could Cause to Serious Catastrophe to THSR,” Jan. 16, 1998. *United Daily*, “Ministry of Finance Minister: BOT Project No Exceptional to General Bank Laws and Regulations,” Jan. 17, 1998.

⁷³ See *Economic Daily*, “President Lee: THSR Must be Done,” Mar. 12, 1998. *Economic Daily*, “President Endorsement with Several Considerations,” Mar. 12, 1998.

⁷⁴ See *United Daily*, “Postpone THSRC Financial Problem after Presidential Election,” Aug. 15, 1999. BOHSR, “Status of Tri-Party Coordination for the Investment of the High Speed Rail Project,” *HSR Newsletter* 4: 37 (1999): 1.

2000. Approximately, the THSRC itself needed to be responsible for searching for 30% of the capital for the project and then it could be allowed to borrow the other 70% from the Syndicate Banks.⁷⁵ Due to the encouragement from the government's endorsement, more than thirty domestic banks expressed an intention to join the THSR project loan and offered more than half of the needed amount.⁷⁶ Finally, the 323.3 billion NTD (10.35 billion USD)⁷⁷ loan came from a consortium of twenty-five Taiwanese banks, led by two majority-government owned banks. The period of the loan was twenty years and had a variable rate from 2.15% to 8.22% with different loaning sources in different years from 2000 to 2009.⁷⁸ The high interest in comparison with the current level gave the THSRC a heavy burden. In addition, its responsibility for 30% of the capital also raised a further controversy in terms of domestic politics later.

In March 2000, the same month that the THSR construction finally began, the DPP presidential candidate Shui-bian Chen, a pro-independence lawyer and former mayor of the city of Taipei, defeated his two rivals, one from the KMT and the other from an independent camp mainly formed by former KMT politicians.⁷⁹ Chen and the DPP's victory represented Taiwan's first democratic transition of power to an opposition party. As noted, a number of the companies that composed the THSRC were known to have closer ties with the DPP. Especially Ing was known as an explicit DPP apologist, even though she was a second-generation mainlander. She not only actively supported Chen's campaign during the presidential election in 2000, but also was appointed as an honorary advisor to the president during Chen's eight-year presidency.⁸⁰

⁷⁵ See BOHSR, "Progress of Syndicate Loan to HSR Project," *HSR Newsletter* 4: 48 (2000): 1~2. Control Yuan, 97~110.

⁷⁶ See BOHSR, "Status of Joint Credit Loan to HSR Project," *HSR Newsletter* 4: 45 (1999): 8. Control Yuan, 97~110. *Economic Daily*, "Project Loan Interest Settled: 32 Banks Intended to offer 450 billion NTD Loan," Nov. 30, 1999.

⁷⁷ The annual average exchange rate was 1 USD equaled to 31.2252 NTD in the year of 2000.

⁷⁸ See Control Yuan, 97~110. Also see BOHSR, "Progress of Syndicate Loan to HSR Project." *United Daily*, "Syndicate Loan to HSR Project Settled, HSR Construction Begins 6 Months Later," Feb. 3, 2000.

⁷⁹ The KMT presidential candidate was Lee's former vice president and premier Chan Lien. The other was James Song who was the former governor of the Provincial Government.

⁸⁰ See *Economic Daily*, "Ing, Best Speaker for Chen's National Consulting Committee," Mar. 30, 2000. *United Daily*, "Member Selection of Chen's National Consulting Committee," Apr. 3, 2000.

During its ruling period from 2000 to 2008, the DPP government was seriously criticized for making overdue efforts to help the THSRC to search for the 30% of the needed capital, around 105.3 billion NTD (3.17 billion USD).⁸¹ Between 2003 and 2005 the value of the company's equity was approximately doubled through purchases of preferred stock by the Executive Yuan's Development Fund, some state-owned companies such as the Taiwan Sugar Corporation, China Steel, and China Aviation Corporation, and seven state-owned banks such as the Bank of Taiwan etc.⁸² See Table 7.1. In addition, the THSRC later acquired a second loan of 65.5 billion NTD (2.01 billion USD)⁸³ from another Syndicate Banks in July 2006.⁸⁴ Although all the loaning sources were from seven Taiwanese private banks, allegedly the government was helping to carry out this second project loan.⁸⁵

The THSR project's financial arrangement, especially the second project loan and THSRC's seasoned equity offerings during the eight-year DPP ruling period, has led to some serious political struggles between the DPP government and the opposition KMT.⁸⁶ While the KMT accused the DPP of betraying the BOT's fundamental principle by pouring governmental funds into a private project, the DPP government insisted that its policy was to "invest" but not "sponsor" the THSRC.⁸⁷ In addition, the original five companies that composed the THSR Consortium were also criticized for only sponsoring less than 30% self funds to the THSRC. They did not sincerely intend to realize the THSR project with their abilities. See Table 7.1. Moreover, the THSRC's difficult business operation made the controversial situation more

⁸¹ The annual average exchange rate was 1 USD equaled to 32.531 NTD in the years from 2003 to 2005.

⁸² See Control Yuan, 97~110.

⁸³ The annual average exchange rate was 1 USD equaled to 31.2252 NTD in the year of 2006.

⁸⁴ See footnote 82.

⁸⁵ See *Economic Daily*, "Government Concern on THSRC Second Project Loan?" Aug. 1, 2006.

⁸⁶ See Dong-Yi Huang and Dow-Min Chung, "THSR Financial Controversy and Policy Agenda Setting," *Feng Chia Journal of Humanities and Social Sciences* 11 (2005): 281~309.

⁸⁷ See Government Information Office, "Executive Yuan Secretary Clarifying Government Policy on THSR Finance," *Premier Mailbox*, Nov. 22, 2004. See more detail at Government Information Office website <http://info.gio.gov.tw/ct.asp?xItem=20223&ctNode=1808>

complicated. Among other things, the THSRC was trapped into its heavy loan burden mainly caused by the high interest rate. Its number of daily riders was only nearly 90,000 at the end of 2009 which was still far behind its expected balance number of 145,000.⁸⁸ See Chart 7.2.

Among some other reasons, the THSRC thus had accumulated a huge deficit of 70 billion NTD (2.12 billion USD).⁸⁹ Due to the serious financial trouble, Ing finally stepped down from her position as chairwoman of the THSRC and the government took over the company's control in September 2009.⁹⁰

Table 7.1 THSRC Equity Distribution (public domain)

Category	Stock		Preferred Stock		Total	
	Amount (billions NTD)	Per cent	Amount (billions NTD)	Per cent	Amount (billions NTD)	Per cent
Five Original THSRC Company	23.9	36.77 %	5.5	13.65 %	29.4	27.92 %
Pan State-Owned	14.4	22.15 %	25.4	63.03 %	39.8	37.80 %
Others	26.7	41.08 %	9.4	23.33 %	36.1	34.28 %
Sum	65.0	100.0 %	40.3	100.0 %	105.3	100.0 %

Source: Control Yuan, 99.

The BOT mode also raised another serious conflict between the THSRC and the government during the construction period in the early 2000s. Because a part of the THSR route was built near the Southern Taiwan Science Park, some high technology firms that made, for

⁸⁸ See *Economic Daily*, "New HSR Project Loan with 1.8% Interest Rate; THSRC Chairman Indicates Profits Two Years Later," Jan. 4, 2010.

⁸⁹ See *Economic Daily*, "New HSR Project Loan: 382 Billion NTD with 1.8% Interest Rate" Jan. 9, 2010. The annual average exchange rate was 1 USD equaled to 33.049 NTD in the year of 2009.

⁹⁰ See *United Daily*, "Ing Stepped Down, Ou Becomes THSRC President," Sep. 23, 2009. *Economic Daily*, "Ing Quit, Ou Appointed," Sep. 23, 2009.

example, semiconductors in the park were worried that their manufacturing process might be affected by the vibration when the THSR rolling stocks passed by. The THSRC claimed they built the THSR according to the government's policy made in the early 1990 as noted in chapters three and four. This alignment policy was settled before the government decided to build the park next to the THSR route. However, the government not only wanted the THSRC to change some of the THSR civil design in that section but asked it to deal with the problem. Thus the THSRC and the government soon entered into a serious political and legal struggle. The cabinet at the time was even reshuffled because of the difficult conflict caused by the case. The government eventually took full responsibility, but the next issue concerning which government department should take it raised another political conflict. Rather than the MOTC, the National Science Council that supervised the Southern Taiwan Science Park was assigned to tackle the vibration problem. But the story did not end there. It later involved the phenomenon of the political and engineering patronage that I discuss in chapter six. The lowering vibration project was allegedly planned by a local company and its political apologists and cost the government a huge and extra amount of money.⁹¹

In short, unlike the long planning period before its construction beginning in 2000, the THSR project has been fading in terms of identity formation. It became one of the most controversial issues between the DPP and KMT.

⁹¹ See *United Daily*, "Executive Yuan Discusses THSR Vibration Case," Feb. 24, 2001. *United Daily*, "Vibration Case Indicted," May 17, 2006. *United Daily*, "Prosecutor Questions the Vibration Case over Spending," Oct. 14, 2006. *United Daily*, "How much Money and How Many Politicians Wasted Due to Lowering Vibration Project," Dec. 26, 2006.

Chart 7.2 THSR Daily Passenger Number Forecast (public domain)

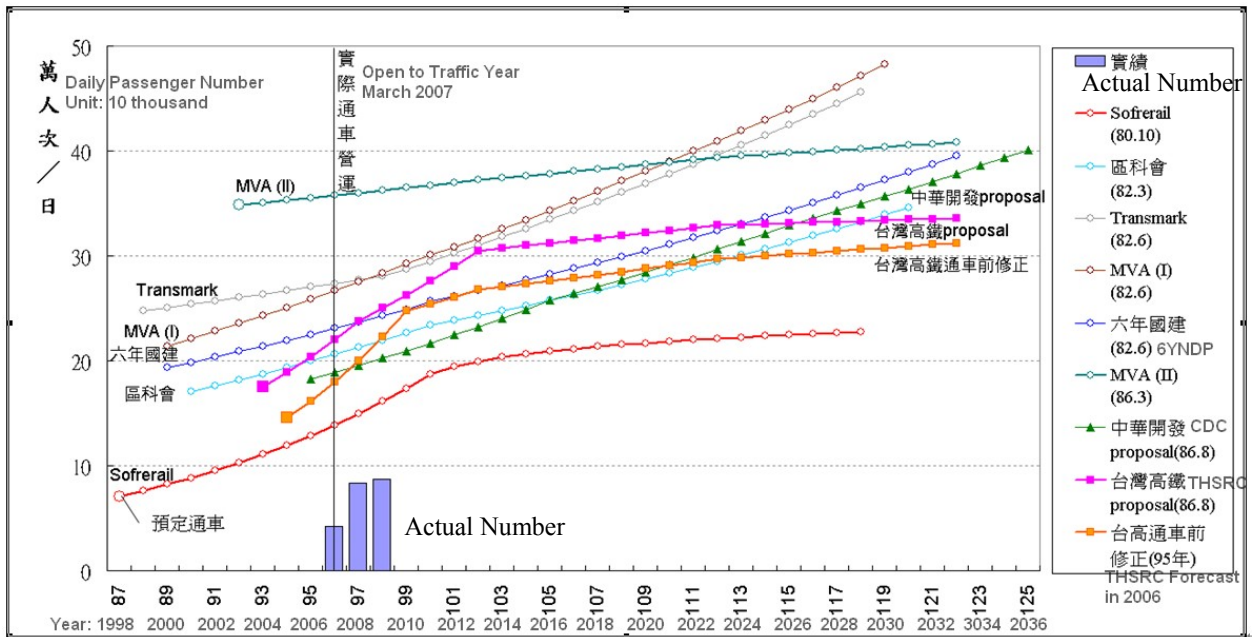

* Transmark, MVA (I) and (II) were the professional institutes that the BOHSR and MOTC commissioned to do the THSR daily passenger number forecast.

Source: Control Yuan, 123.

CHAPTER 8

CONCLUSION:

SUBJECTIVITIZING ENGINEERING/POLITICAL IDENTITY

We should be in a position to cumulate knowledge, derived from many different traditions, to be aware of alternative forms of understanding, to beware claims of a one best way, and to remember that we have lived with technology for a very long time.—David E. H. Edgerton¹

Taiwanese HSR engineers conducted the THSR project through a hybrid practice inherited from their diverse engineering history and culture. The THSR cannot be characterized as just another Japanese Shinkansen, French TGV, or German ICE. While the Japanese have acknowledged in public statements that the THSR is not another Shinkansen line, the THSR is a Taiwanese version of this system. The THSR was a technological reconstruction thoroughly embedded within local knowledge and culture to the point where the original maker could no longer recognize their technology. However, the Taiwanese also paid an unwanted price through this process of hybrid engineering.

The THSR project also clearly reflected and enacted critical aspects of Taiwan's historically political struggles over the competition between Taiwanese/Chinese identity discourses. It facilitated both discourses to seek out their foreign power, by which their identity-shaping/-making power could be respectively strengthened and solidified over the Taiwanese and Chinese peoples on the island. The THSR project reflected different values and even political conflicts between the two discourses. While the Chinese policy actors represented a more national and rational planning perspective than the Taiwanese policy actors, the latter wanted to conduct the THSR project through a more local and political approach than the former.

¹ David E. H. Edgerton, "From Innovation to Use: the Eclectic Theses on the Historiography of Technology," *History and Technology* 16 (1999): 136.

The Chinese policy actors led the THSR project toward a privatized model, but a local Taiwanese consortium, the THSRC, defeated its Chinese KMT-run rival and obtained the project's BOT contract with the government. However, the Taiwanese/Chinese identity politics did not stop impacting the project there. On the one side, as the most remarkable leader in terms of the political identity shaping in 1990s Taiwan, Lee encouraged the THSRC to switch from its planned Euro core HSR system to the Japanese Shinkansen system in order to achieve his political purpose of helping Taiwan achieve an international position among China, Japan and the U.S. in East Asia. On the other side, the THSR project helped to stimulate and shape identity politics in Taiwan. It was the engineering culture and tradition of hybridity embedded within the THSR project that enabled it to carry out the competition of the Taiwanese/Chinese identity discourse. As a result, Taiwan's engineering culture has a larger significance in the sense that it has constructed Taiwan's culture along with Japanese culture, Western culture and other cultures. The hybrid culture has gradually become the Taiwanese culture.

The THSR project displayed a similar trajectory from Taiwan's technological/political dependence on foreign power to its competition with them to its struggles for subjectivity against them. This trajectory applied to both the Taiwanese engineering practice and identity making process. Rather than a symbolic description, both have been working together and shaping each other. This symbiotic relationship not only demonstrated why they shared a similar symbolic trajectory but also indicated that they actually referred to each other and represented the same phenomenon of searching for independence in Taiwan.

8.1 Co-producing Dependent/Subjective Engineering/Political Identity

*An event or fact is common knowledge among a group if everyone knows it, everyone knows that everyone knows it, everyone knows that everyone knows that everyone knows it, and so on.*²

Michael Suk-Young Chwe, in his book *Rational Ritual: Culture, Coordination and Common Knowledge*, expands upon Benedict Anderson's insight of an imagined community³ in ways of investigating the relations between identity shaping and common knowledge making from an interactive viewpoint. He argues that while belonging to a shared community would be a way to shape common knowledge, conversely, common knowledge which consists of rational knowledge and cultural customs could help create a shared community.⁴ Moreover, instead of a separate or conflicting relationship, one of Chwe's intentions has been to offer an idea that rational knowledge and cultural customs could be compatible with each other and even produce a close and interactive relationship. His idea of common knowledge and its relations to identity formation helps this project to conceptualize how engineering practice might have been embedded within the identity politics in Taiwan.

No longer just a kind of systematic knowledge, the engineering culture of hybridity in the THSR project has been intertwined with economic ration, engineering convention and international/identity politics. They did not operate in different parallel tracks. Neither could they be categorized to produce impacts on the THSR project at separate stages. Rather, they shaped and fulfilled each other all the way from its inception to completion. Taiwan's manipulated international politics nurtured its engineering tradition of hybridity since the 1960s. Later, this engineering tradition of hybridity allowed the international/identity politics to be carried out with some Chinese/Taiwanese intentions in the THSR project in the 1990s. For

² Michael Suk-Young Chwe, *Rational Ritual: Culture, Coordination and Common Knowledge* (Princeton, NJ: 2001), 9~10.

³ See Benedict Anderson.

⁴ Chwe, 91~3.

instance, Lee's wish of intercepting the Euro HSR core system and introducing the Shinkansen system to the THSR project under construction would not be possible if Taiwanese engineers had no hybrid tradition, experience and practice. In this symbiotic shaping process, both Taiwan's hybrid practice and international politics were dedicated to making Taiwan independent from other foreign communities either in terms of engineering or political identity. In short, they shaped each other and worked together to carry out their common aim to acquire identity and subjectivity for the majority of the people on the island of Taiwan.

Either Identity or subjectivity was one of the important characteristics that featured the common knowledge in Taiwan. In the case of the THSR project, I have argued that its rational knowledge and political intentions have been relentlessly working together, even though they sometimes conflicted with each other. While Taiwanese engineers have been developing their special cannibalization and hybrid tradition nurtured by Taiwan's international politics, Taiwanese politicians have understood their engineers as being able to undertake hybrid projects and they exploited this capability to bring themselves and their people political benefits. As a result, every Taiwanese engineer and politician knows the inalienable importance of identity/subjectivity in terms of resistance to those technological/political power outside the island of Taiwan. Every one of them knows that every one of them knows this. Every one of them knows that every one of them knows that every one of them knows this. This common knowledge has shaped the Taiwanese engineering/political community as an integrated community that is different from others and even against the Chinese community.

8.2 Opening the Black Box Is Not Equal to Reproduction

Their tradition of hybridized practice earned Taiwanese engineers opportunities to open some black boxes in terms of the advanced and complicated technology imported from the West and Japan. Taiwanese HSR engineers have not only learned how to manage and even

manipulate potential foreign makers but also intended to lead the THSR building work. Moreover, they also attempted to operate and maintain the THSR system independently from foreigners. Although they still have some significant difficulties making the HSR technology, Taiwanese HSR engineers have displayed a capability to compare, integrate and optimize the technology. According to my interviews, they certainly are not satisfied with this, but their accumulated experience and knowledge have created a different approach to practicing engineering. This hybrid practice has created in Taiwan some engineering niches such as making high value-added components from the bottom up. Other countries like Taiwan in terms of being newly industrial economies or late developing countries⁵ might be interested in this engineering practice that could bring economic development. This hybrid practice would earn technology importers like Taiwan some substantial participation and control over their transferred systems from so-called advanced countries. Furthermore, they might be able to build their local engineering specialties and niches by referring to Taiwan's experience.

However, a Taiwanese version of a HSR system required some practical conditions for it to be achieved. Among these conditions, engineering policy, education and the local private sector were three of the most important. Although Taiwan's engineering tradition of hybridity was mainly shaped by its distorted international politics, its governmental institutions, such as the Taiwan Railways and the BOHSR, still played a key role in leading and shaping what engineering knowledge and practice they attempted to acquire in the case of the THSR project. Taiwan's engineering culture of hybridity has also benefited from the abundance of engineers that were educated from various advanced countries. In addition, as I demonstrated in chapters five and six, Taiwan's private sector was a pivotal actor that not only inherited the engineering culture of hybridity from the governmental institutes, but also contributed to this tradition and

⁵ See Sumiya *et al.* Also see Alice H. Amsden and Wan-wen Chu, *Beyond Late Development: Taiwan's Upgrading Policies* (Cambridge, MA: MIT Press, 2003).

even pushed it further. For example, the THSRC introduced more aggressive strategies for inviting multiple kinds of foreign engineering expertise, financial planning and system management into Taiwan than the Taiwan Railways, the BOHSR and the Institute of Transportation etc.

Rather than reproducing another intact HSR system, the THSR engineering might be more appropriately characterized as a hybridized system. The Taiwanese had to pay an extra price for this, such as redundant design and installation, than it would have if it had simply imported an intact HSR system. This engineering hybridization also introduced some responsibilities for risk back to the technology importers. This hybrid practice also caused the original manufactures to hesitate to transfer their critical technologies to this kind of importer like Taiwan. The THSRC has been criticized that it learned little critical core HSR technology and created few possibilities of exporting another THSR to other countries like the Korean KTX. In addition to the situations of construction delay, system design redundancy and safety design waste, the engineering culture of hybridity sometimes has brought political patronage into a certain number of public construction projects in Taiwan. Moreover, how to get rid of technological dependence on other advanced countries is still very challenging. Although the THSRC has made efforts and developed some ways to keep itself independent from Japan, it also realizes that more time and resources are needed. However, from another perspective, the THSR project has also brought Taiwan some opportunities of, among other things, manufacturing HSR components from the bottom up.

As a result, although the THSR project has opened some black boxes of the HSR technology, this does not mean that Taiwan would be able to make or export another HSR. However, this project offered a nice overview to examine a Taiwanese engineering program of how to plan, build and manage transferred technologies. This program was mainly influenced by

Taiwan's history and politics, but some institutional factors as noted above also shaped the program in significant ways. This opening practice brought Taiwan some experience, participation and independence in the process of technology transfer.

The more important discovery that I highlight through this case study of the THSR project is that Taiwan's history, politics and engineering program of hybridity have been intertwined and they have shaped and aided each other. This engineering program represented not only what Taiwanese engineers have practiced, but also the kind of common knowledge the majority of the people on the island of Taiwan has shared. How to do engineering has been an important and inalienable approach for the Taiwanese to regard, understand and identify themselves. Taiwan's engineering culture contributes to the shaping of its culture in ways that are different from others by internalizing the Japanese and western cultures into it.

8.3 When the THSR Hits a Speed Bump

The THSR project was one of the most remarkable infrastructural projects in Taiwanese history in terms of its cost, construction scale and political impacts. The Lee government understood this and so did the DPP government. While Lee intended to exploit international political interests through the THSR project, the DPP government poured state capital into the project in order to facilitate its completion during its period in office. Not even to mention those local politicians and interest groups who actively jumped onto the project either at the planning or building stage from the 1990s to the middle 2000s. Political considerations and intervention could easily be detected in both the planning and building processes of the project. It should come as no surprise that this also caused numerous political struggles in terms of discourse and party competition.

Although the political struggles over the THSR project gradually stepped back from international politics when it approached completion, domestic political struggles became more

and more prominent over time. The project's financial planning and arrangement triggered one of most serious conflicts between the DPP and KMT. In addition, business for the THSRC has not gone as well as it and the government expected. It looks unlikely that the THSRC will be able to realize its original BOT proposal against the China Development. All of these political and business phenomena have caused the THSR to hit a speed bump in the sense that the project not only has to face plenty of unexpected and practical difficulties but also it no longer inspires the majority of the people on the island of Taiwan like it used to.

According to Benedict Anderson, imagination has been a key factor in building and shaping communities and nationalism.⁶ The inspiration and imagination brought by engineering and technological development has for years been a significant but ignored means for the people of Taiwan to clarify their identity and formulate a sense of community. However, like those cutting edge technologies in this so-called ten-time-speed society, the majority of the people of Taiwan has become used to the THSR technology and even has questioned its vision for political and developmental in the few years since it opened to traffic. This Taiwanese/engineering imagination did work in terms of identity formation but it might be less powerful and last a shorter time than other kinds of imagination. The move toward independence as a country has been abruptly halted and everyone is scrambling to re-imagine the future of Taiwan with the DPP and KMT really in competition.

⁶ See Benedict Anderson.

BIBLIOGRAPHY

- Adams, Vincanne. "Randomized Controlled Crime: Postcolonial Sciences in Alternative Medicine Research." *Social Studies of Science* 32 (2002): 659-90.
- Adas, Michael. *Machines as the Measure of Men: Science, Technology, and Ideologies of Western Dominance*. NY: Cornell University Press, 1998.
- AEA. <http://www.aeat.co.uk/cms/> (accessed on Nov. 27, 2009).
- Alliance of the Taiwan High Speed Rail. *General Policy on HSR Investment and Construction*. Taipei: Alliance of the Taiwan High Speed Rail, 1997.
- Alstom. "Official Opening of the First High Speed Railway Line in Korea." Mar. 30, 2004. http://www.alstom.com/pr_corp_v2/2004/20533.EN.php?languageId=EN&dir=/pr_corp_v2/2004/&idRubriqueCourante=23132&cookie=true (accessed on Nov. 22, 2009).
- Amsden, Alice H. and Wan-wen Chu. *Beyond Late Development: Taiwan's Upgrading Policies*. Cambridge, MA: MIT Press, 2003.
- Anderson, Benedict. *Imagined Communities: Reflections on the Origin and Spread of Nationalism*. NY: Verso, 2006.
- Anderson, Warwick. "Postcolonial Technoscience." *Social Studies of Science* 32 (2002): 643-58.
- Apple Daily*. "500 Passengers in Serious Risk, THSR Conductor Allegedly Fell in Sleep while Operating." May 10, 2010.
- Asahi Shimbun* (日本朝日新聞). "First Shinkansen Export: THSR Trial Operation in March (初輸出新幹線、軌道乗るか 台湾で試験走行3カ月遅れ)." Feb. 11, 2005.
- Baber, Zaheer. *The Science of Empire: Scientific Knowledge, Civilization, and Colonial Rule in India*. NY: State University of New York Press, 1996.
- BCC News Network*. "Hardly Solvable THSR Problems between Taiwan and Japan." Apr. 26, 2006.

- . “MOTC Accused the Central JR, Even the Japanese Government No Power over Central JR.” Apr. 24, 2006.
- Bhabha, Homi K. *The Location of Culture*. London: Routledge, 1994.
- Bien, Chen-Hsin (卞政新). “Aerial Cranes Self-making for Gas-locomotives Factories.” *Taiwan Railways Journal* 34 (1966): 1-20.
- Bijker, Wiebe E. “America and Dutch Coastal Engineering: Differences in Risk Conception and Differences in Technological Culture.” *Social Studies of Science* 37 (2007): 143-51.
- Bureau of High Speed Rail (BOHSR), Ministry of Transportation and Communications. “From the Director-general of BOHSR.”
<http://www.hsr.gov.tw/homepage.nsf/beff9cd4905e8649482569210010e4a3/cedfba1a2e45b2c482570a100135aaa!OpenDocument> (accessed on Mar. 26, 2010).
- . “BOHSR Publications.” <http://www.hsr.gov.tw/homepage.nsf/publication?OpenFrameset> (accessed on Feb. 25, 2010.)
- . “The List of the Commissioned Research Reports.”
<http://www.hsr.gov.tw/homepage.nsf/5570525aaf0566824825739d000a2023/9eb95e36b8e470f34825739d000c0560!OpenDocument> (accessed on Feb. 25, 2010).
- . “Highlight.” <http://www.hsr.gov.tw/homepage.nsf/homepage-eng?OpenFrameset> (accessed on Jan. 15, 2010).
- . *Introduction to the THSR Electrical and Mechanical Engineering and System*. Taipei: BOHSR, 2008.
- . *Taiwan HSR Launches a New Era*. Taipei: BOHSR, 2007.
- . *Memorial Collection for the THSR Open to Traffic*. Taipei: BOHSR, 2007.
- . *Best Investment Opportunity to Asia: from Taiwan HSR Commercial Park: Get going, Get with it!* Taipei: BOHSR, 2006.

- . *High Speed Rail Stations: Design and Construction*. Taipei: BOHSR, 2006.
- . *Introduction to Railroad Engineering and Construction*. Taipei: BOHSR, 2006.
- . *Introduction to HSR Track Engineering and Construction*. Taipei: BOHSR, 2006.
- . *Introduction to Other Viaduct Construction Methods: Advancing Shoring Method, Balanced Cantilever Method and Incremental Launching Method*. Taipei: BOHSR, 2006.
- . *Current THSR Construction*. Taipei: BOHSR, 2005.
- . “Viewpoint.” *HSR Newsletter* 9: 107 (2005): 2.
- . “HSR Encyclopedia: Axle Counters.” *HSR Newsletter* 10: 113 (2005): 16.
- . *Introduction to New Austrian Tunnel Method*. Taipei: BOHSR, 2005.
- . *Introduction to Full-span Precast & Launching Method*. Taipei: BOHSR, 2004.
- . “Main Specifications of HSR Model 700T Train.” *HSR Newsletter* 8: 97 (2004): 3-4.
- . “Encyclopedia of HSR: Uni-directional Signaling & Bi-directional Signaling.” *HSR Newsletter* 8: 85 (2003): 2.
- . “What is the Independent Verification and Validation (IV&V)?” *HSR Newsletter* 7: 80 (2002): 7.
- . *Developmental Ideas on HSR Stations and Adjacent Areas*. Taipei: BOHSR, 2001.
- . “MOTC Consented to Japanese Shinkansen System as the Reference System for Core System.” *HSR Newsletter* 6: 65 (2001): 4.
- . “Application for a Change of HSR Core System.” *HSR Newsletter* 6: 61 (2001): 7.
- . *Planning on THSR’s Three New Stations: Miaoli, Chunghua and Yunlin*. Taipei: BOHSR, 2000.
- . “Progress of Taiwan HSR Project.” *HSR Newsletter* 5: 59 (2000): 1-2.
- . “THSRC Signed Memorandum of Adopting Japanese Shinkansen System.” *HSR Newsletter* 5: 53 (2000): 1.

- . “Progress of Syndicate Loan to HSR Project.” *HSR Newsletter* 4: 48 (2000): 1-2.
- . “Progress of the Taiwan HSR Project.” *HSR Newsletter* 4: 47 (2000): 1~2.
- . *Determining Factors of Choosing Core Mechanical and Electronic Systems*. Taipei: BOHSR, 1999.
- . “Taiwan South-North High Speed Rail Construction and Operation Contract.” In *Collection of THSR BOT Contract and Others*. Taipei: BOHSR, 1999.
- . “Status of Joint Credit Loan to HSR Project.” *HSR Newsletter* 4: 45 (1999): 8.
- . “Selection of HSR Mechanical & Electrical Systems.” *HSR Newsletter* 4: 42 (1999): 7-8.
- . “Progress of ‘Items Committed by the Government’ of HSR Private Sector Investment Project (Conclusion).” *HSR Newsletter* 4:42 (1999): 1-2.
- . “All the ‘Items Committed by Government’ of the HSR Project Completed.” *HSR Newsletter* 4: 40 (1999): 1.
- . “Status of Tri-Party Coordination for the Investment of the High Speed Rail Project.” *HSR Newsletter* 4: 37 (1999): 1.
- . “Information on the Contract to Build, Operate, and Transfer the Taiwan North-South High Speed Rail (HSR).” *HSR Newsletter* 3: 31 (1998): 8-12.
- . “Contract Officially Signed Between the Ministry of Transportation and Communications and the Taiwan High Speed Rail Company.” *HSR Newsletter* 3: 30 (1998): 1-2.
- . “A Report to President Lee: Progress of HSR C&O Agreement.” *HSR Newsletter* 1: 26 (1998): 1.
- . “Executive Yuan Gives Consent to HSR C&O Agreement.” *HSR Newsletter* 1: 25 (1998): 5.
- . “Conclusions.” *HSR Newsletter* 1: 24 (1998): 8.
- . “HSR BOT Contract Negotiation Completed.” *HSR Newsletter* 1: 23 (1998): 9.

- . *Proceedings of Workshop for High Speed Railways in Taiwan*. Taipei: BOHSR, 1997.
- . “Selection and Evaluation of HSR Private Investment Applications.” *HSR Newsletter* 1: 20 (1997): 4-5.
- . “Rolling Stock System (1).” *HSR Newsletter* 1: 18 (1997): 7-8.
- . “BOHSR Gives Briefings on Outcomes of HSR Detailed Design to Qualified Applicants.” *HSR Newsletter* 1: 14 (1997): 6.
- . “Incentive Negotiation with Qualified BOT Applicants.” *High Speed Rail Newsletter* 1: 14 (1997): 8.
- . “Progress on General Consultant Services to HSR Project.” *High Speed Rail Newsletter* 1: 14 (1997): 7-8.
- . “Qualification Examination for HSR Private Investment (BOT) Project Completed: Qualified Applicants Invited to Discuss Follow-up Work Plan.” *High Speed Rail Newsletter* 1: 13 (1997): 3.
- . *Memorial Selections of Mr. Chou Jin-Sean (邱錦祥): the HSR Spirit*. Taipei: BOHSR, 1996.
- . *Memorial Selections of Mr. Chou Jin-Sean (邱錦祥): the HSR Research and Planning*. Taipei: BOHSR, 1996.
- . “High Speed Rail Meeting Future Transportation Demand.” *High Speed Rail Newsletter* 1: 1 (1995): 1-2.
- . *High Speed Rail/HSR Newsletter*. Taipei: BOHSR, 1995~.
- Buszynski, Leszek. *Asia Pacific Security: Values and Identity*. NY: Routledge, 2004.
- Callahan, William A. *Contingent States: Greater China and Transnational Relations*. Minneapolis, MN: University of Minnesota Press, 2004.

- Campos, Javier and Ginés de Rus. “Some Stylized Facts about High-speed Rail: A Review of HSR Experiences around the World.” *Transport Policy* 16: 1 (2009): 19-28.
- Carroll, Patrick. *Science, Culture, and Modern State Formation*. Berkeley, CA: University of California Press, 2006.
- CECI Engineering Consultants, Inc., Taiwan. <http://www.ceci.org.tw/english/index.htm>
- . *Research Report on THSRC Rail Engineering and Construction Contract*. Taipei: BOHSR, 2004.
- Central Bank of the Republic of China (Taiwan). “Foreign Exchange Regime.” <http://www.cbc.gov.tw/content.asp?CuItem=1879> (accessed on Jan. 11, 2010).
- Central Daily*. “Save the Taiwan HSR Budget: Hsinchu, Chiayi and Tainan Protest.” July 27, 1993.
- . “Southern Counties Protest the Taiwan HSR Budget Cut.” July 25, 1993.
- . “Lee No Specific Stance to Build the Taiwan HSR or Not.” July 21, 1993.
- . “We Will Regret Tomorrow If We Don’t Build the Taiwan HSR Today: Several County Representatives Advocated Organizing Pro Groups.” July 20, 1993.
- Central Election Committee Database. <http://210.69.23.140/cec/cechead.asp> (accessed on Mar. 18, 2010).
- Central Japan Railway Company. “Company Profile: Operating Area.” <http://english.jr-central.co.jp/company/company/about/area.html> (accessed on Nov. 28, 2009).
- Central News Agency*. “THSRC: High Paid Foreign Manager Earned International Competitively.” Sep. 24, 2009.
- . “Japan Press Applauds THSR Open to Traffic.” Jan. 5, 2007.
- . “High-Speed Rail to Hire 52 Foreign Train Conductor.” Aug. 28, 2006.
- . “MOTC Complained Taiwan Shinkansen Irresponsible Words.” Apr. 24, 2006.

- . “MOTC Warned Taiwan Shinkansen for THSR Conductor Training.” Apr. 24, 2006.
- . “Nita Ing: One Year Delay of the THSR’s Open to Traffic.” Sep. 8, 2005.
- . “THSR Core System Progress Less than 40%.” Sep. 6, 2005.
- . “Central JR Refused to Endorse the THSR.” Jan. 28, 2005.
- . “THSRC No Comments on Lee-Ing Meeting.” Aug. 11, 1999.
- Chang, Bi-yu. “From Taiwanisation to De-sinification: Culture Construction in Taiwan since the 1990s.” *China Perspective* 56, 3 (2004).
- Chang, Hui-Ying (張慧英). *Teng-hui Lee’s 12-Year Ruling 1988~2000 (超級外交官: 李登輝和他的務實外交)*. Taipei: Commonwealth Publishing Co., Ltd., 2000.
- . *Super Diplomatist: Lee Teng-hui and His Pragmatic Diplomatic Policy*. Taipei: Commonwealth Publishing Co., Ltd., 1996.
- Chang, Kuo-Yi (張國儀). “Humble and Hard Working Engineer: Special Interview to an Alumnus Chung-Chun Kao (高聰忠), THSRC Senior Engineer.” *Electrical Newsletter, Department of Civil Engineering, National Taiwan University* 5 (2008).
<http://epaper.ce.ntu.edu.tw/vol.5/TCKao.html> (accessed on Nov. 11, 2009).
- Chang, Mau-Kuei. “Taiwan’s Nationalistic Politics and Its Difficult ‘Status Quo’.” *The Copenhagen Journal of Asian Studies* 21 (2005): 91-124.
- . “Taiwan’s Democratic Movement and Push for Independence.” *International Institute for Asian Studied Newsletter* 34 (2004): 151-2.
- Chatterjee, Partha. *The Politics of the Governed: Reflections on Popular Politics in Most of the World*. Delhi: Permanent Black, 2006.
- Chen, Cheng-Hsiang (陳正祥) and Chi-Hsian Dwan (段紀憲). “On Taiwan’s Population.” *Quarterly Journal of Bank of Taiwan* 4 (1951): 39-41.

- Chen, Dong-Sheng (陳東升). *Making it Integrated: Organizational Networks in Taiwan's Integrated-circuit Industry*. Taipei: Socio Publishing Co., Ltd., 2008.
- Chen, Fang-Ming (陳芳明). *Colonial Modernity: Historical and Literary Perspectives on Taiwan*. Taipei: Rye Field Publications, 2004.
- . *Postcolonial Taiwan: Essays on Taiwanese Literary History and Beyond*. Taipei: Rye Field Publications, 2002.
- Chen, Kuan-Hsing (陳光興). *Towards De-Imperialization: Asia as Method*. Taipei: Shinren Publications, 2005.
- Chen, Kuo-Long (陳國隆). “Evolution of National Expressway Bridge Engineering Techniques.” In *Proceedings of the 12th Taiwan Area National Expressway Engineering Bureau Conference*. Taipei: MOTC, 2002.
- <http://gip.taneeb.gov.tw/ct.asp?xItem=11724&CtNode=2798> (accessed on Dec. 3, 2009).
- Chen, Ming-Tong (陳明通). *Faction Politics and Political Changes in Taiwan (派系政治與台灣政治變遷)*. Taipei: Yue-Dan Publication, 1995.
- Chen, Shih-Meng S. (陳師孟), Chung-Cheng Lin (林忠正), C. Y. Cyrus Chu (朱敬一), Ching-hsi Chang (張清溪), Jun-ji Shih (施俊吉) and Jin-Tan Liu (劉錦添). *Disintegrating KMT-State Capitalism: A Closer Look at Privatizing Taiwan's State—and Party—Owned Enterprises*. Taipei: Taiwan Society, 1991.
- Chen, Te-Nian (陳德年). “Railway Electrification.” *Engineering (工程)* (1975): 831-850.
- Chen, Yung-Hsiang (陳永祥), Yeong-Bin Yang (楊永斌), Chen-Far Hung (洪振發), Chia-Chi Sung (宋家驥), J. D. Yao (姚忠達), Wen-Jiunn Ko (柯文俊) and Yan-Hui Huang (黃燕輝). *HSR Vibration Study: Final Report*. Taipei: BOHSR, 2001.

- Chen, Yung-Yi (陳永毅) and Chao-Lung Tsai (蔡朝榮). *Interfacial Integration and Management in the Building Process of HSR Civil Construction and Core System*. Taipei: BOHSR, 2004.
- Chiao, Chi-Chang (趙既昌). *U.S. Aid to Taiwan (美援的運用)*. Taipei: Linking Publishing Co., 1985.
- Chien, Li-Xin (錢立新) ed. *World HSR Technologies*. Beijing, China: China Railway Publication, 2003.
- Chien, Sechin Y.S. and John Fitzgerald, ed. *The Dignity of Nations: Equality, Competition, and Honour in East Asian Nationalism*. Hong Kong: Hong Kong University Press, 2006.
- Chien, You-hsin Eugene (簡又新). "Promoting the Western Taiwan Corridor: HSR's Policy Background." *Central Daily Times*, July 28, 1992.
- Chinatimes*. "13 Mins without Conducting on THSR Train." May 10, 2010.
- . "THSRC Complained Taiwan Shinkansen Altitude." Sep. 8, 2005.
- . "THSR Miserable Fate Caused by Derailed Relationship between Taiwan and Japan." June 21, 2005.
- . "MOTC Solutions to the Taipei Platform Conflict between Taiwan Railways and THSRC." Feb. 27, 2003. <http://www.iot.gov.tw/ct.asp?xItem=103751&CtNode=1066> (accessed on Nov. 19, 2009).
- . "Provincial Government Planning HSR and Other Seven Transport Constructions." Jan. 31, 1990.
- Chinatimes Express*. "Wrong Marriage with Taiwan Shinkansen Making Trouble to Ing." Sep. 9, 2005.
- Chinatimes Nightly*. "Taiwan HSR Project and Land Tax Policy Needed Political Solutions." July 21, 1993.

- Ching, Leo T. S. *Becoming "Japanese": Colonial Taiwan and the Politics of Identity Formation*. CA: University of California Press, 2001.
- Common Daily*. "On Land Acquisition." July, 1993.
- Chou, Ching-Wen (鄒景雯). *Teng-hui Lee's Governance Recording (李登輝告白實錄)*. Taipei: Ink Publication, 2001.
- Chou, Kuei-Fan (邱貴芬). "The Japanese Memory and New Historical Imagination in Taiwan." In *Reviewer Thirty: the Selections of the Taiwanese Literature in the Thirtieth Year 1978-2008*, edited by Ray-Tan Lee, 360-89. Taipei: Chiuko Publication, 2008.
- Chow, Jin-Hung (周京弘). "Valuing the Benefit of High Speed Rail System: Studies on Taipei-Taichung Route and Taipei-Kaohsiung Route." Maser thesis, National Taiwan University, 2005.
- Chuang, Su-Yu (莊素玉). "Ing: Wants to Prove Taiwan Society's Capability." *Commonwealth Magazine* 198 (1997): 52-8.
- Chung, Shin-Yi (仲心儀). "A Research about Developmental States at Taiwan in the Relationship of State-Business Transformation: The Example of Taiwan High Speed Rail Corporation." Master thesis, Yuan Ze University, 2004.
- Chung, Wen-Ming (鍾文明). "A Model on Market Boundaries of High Speed Rail and Conventional Rail Serving a Transportation Corridor." Master thesis, National Chao-Tung University, 1995.
- Chung-Hua Institution for Economic Research. *High Speed Rail in the Twenty-first Century*. Taipei: Chung-Hua Institution for Economic Research, 1989.
- Chwe, Michael Suk-Young. *Rational Ritual: Culture, Coordination and Common Knowledge*. Princeton, NJ: 2001.
- Chyu, Fu-Hen (瞿福亨). "North Link Line Railway." *Engineering (工程)* (1975): 851-8.

Clark, Cal. "The Statehood of Taiwan: A Strange Case of Domestic Strength and International Challenge." In *The "One China" Dilemma*. Edited by Peter C. Y. Chow, 81-96. NY: Palgrave Macmillan, 2008.

Congress of House of Representatives, Committee on Transportation and Infrastructure, Subcommittee on Railroads, Pipelines, and Hazardous Materials. *International High-speed Rail Systems: Hearing Before the Subcommittee on Railroads, Pipelines, and Hazardous Materials of the Committee on Transportation and Infrastructure, House of Representatives, One Hundred Tenth Congress, first session, April 19, 2007*. Washington D.C.: U.S. G.P.O., 2007.

Control Yuan. *Review on the Effect of the Taiwan HSR BOT Policy Strategy and Implementation*. http://www.cy.gov.tw/ourpaper.asp?AP_Code=eDoc&Func_Code=t01&case_id=09800058 2 (accessed on Jan. 14, 2010).

Corcuff, Stéphane, ed. *Memories of the Future: National Identity Issues and the Search for a New Taiwan*. NY: M. E. Sharpe, 2002.

Coto-Millan, Pablo, Vicente Inglada and Belen Rey. "Effects of Network Economies in High-Speed Rail: The Spanish Case." *Annals of Regional Science* 41: 4 (2007): 911-25.

Council for Economic Planning and Development. "History and Mission." <http://www.cepd.gov.tw/encontent/m1.aspx?sNo=0001432&key=&ex=%20&ic=&cd=> (accessed on Oct. 24, 2009).

———. "Implementation Review Report on the 12 Construction Plans." *Industry of Free China* 83: 4 (1995): 11-23.

———. *Six-Year National Development Plan (Draft) (1991~1996) Volume 1/2: Goals of Macro Economic Development*. Taipei: Economic Council, 1990.

- De Carlo, Laurence. "The French High-Speed Mediterranean Train Decision Process: A Large-Scale Public Decision Case Study." *Conflict Resolution Quarterly* 24 (2006): 3-30.
- De Rus, Gines and Gustavo Nombela. "Is Investment in High Speed Rail Socially Profitable?" *Journal of Transport Economics and Policy* 41: 1 (2007): 3-23.
- Directorate General of Budget, Accounting and Statistics of Executive Yuan. "Annual Budget of the Year of 1994." <http://win.dgbas.gov.tw/dgbas01/83btab/83b101.htm> (accessed on Oct. 26, 2009).
- Downey, Gary L. *The Machine in Me: an Anthropologist Sits among Computer Engineers*. NY: Routledge, 1998.
- . "CAD/CAM Saves the Nation?: Toward an Anthropology of Technology." *Knowledge and Society* 7 (1992): 143-68.
- and Juan Lucena. "Knowledge and Professional Identity in Engineering: Code-Switching and the Metric of Progress." *History and Technology* 20 (2004): 393-420.
- Dunn, James A. Jr. and Anthony Perl. "Policy Networks and Industrial Revitalization: High Speed Rail Initiatives in France and Germany." *Journal of Public Policy* 14, 3 (1994): 311-43.
- Dwan, Chan-Pu (段承璞) ed. *Taiwan's Economy after WWII (台灣戰後經濟)*. Taipei: Ren-Jen Publication, 1994.
- Economic Daily News*. "New HSR Project Loan: 382 Billion NTD with 1.8% Interest Rate." Jan. 9, 2010.
- . "New HSR Project Loan with 1.8% Interest Rate; THSRC Chairman Indicates Profits Two Years Later." Jan. 4, 2010.
- . "Ing Quit, Ou Appointed." Sep. 23, 2009.

- . “THSRC Reliable? Japanese Rolling Stock, French Conductors and British Verification & Validation.” Dec. 25, 2006.
- . “Government Concern on THSRC Second Project Loan?” Aug. 1, 2006.
- . “4 Years Later, THSRC Settled Down with Eurotrain with 6.50 Million USD.” Nov. 27, 2004.
- . “Eurotrain Wins Superficially.” Mar. 16, 2004.
- . “THSRC Required to Compensate Eurotrain 24 NTD.” Mar. 16, 2004.
- . “HSR Special Report 1/3.” Jan. 27, 2003.
- . “Ing, Best Speaker for Chen’s National Consulting Committee.” Mar. 30, 2000.
- . “Lee: No Comment on HSR Business Activity.” Jan. 15, 2000.
- . “Project Loan Interest Settled: 32 Banks Intended to offer 450 billion NTD Loan.” Nov. 30, 1999.
- . “HSR Marriage Failed Due to Discontent with Each Other’s Offering.” Jul. 2, 1998.
- . “President Endorsement with Several Considerations.” Mar. 12, 1998.
- . “President Lee: THSR Must be Done.” Mar. 12, 1998.
- . “Taiwan Star Tested.” on May 4, 1998.
- . “China Development Taking on THSRC: Questioning THSRC French-German Hybrid Rolling Stock.” Sep. 25, 1997.
- . “THSRC Upper Hand on Financial Plan.” Sep. 23, 1997.
- . “HSR Project Draws New Business Generation.” Sep. 17, 1997.
- . “Two Consortia Compete for Taiwan HSR Project: Who Allows Government Spend Less Is the Key.” Sep. 1, 1997.
- . “Euro and Jpn Competing For HSR Project: THSRC and China Development Running for 441.9 Billion NTD Business.” Jan. 16, 1997.

- . “China Development Leads to Run for Taiwan HSR Project.” Jan. 15, 1997.
- . “Foreign HSR Consortia Actively Conducting Integration for Taiwan HSR Project.” Dec. 22, 1996.
- . “Announcing to Invite Private Investment on HSR Project by the End of October.” Oct. 12, 1996.
- . “Three Foreign HSR Consortia Suspicious to BOT Bid Program.” Oct. 1, 1996.
- . “Chung-Yih Lin Stepped down.” Aug. 12, 1996.
- . “Tsai (蔡兆陽; Minister of MOTC): Re-soliciting General Engineering Consultant in Domestic.” Aug. 12, 1996.
- . “6-Year Plan Away From Original Goals.” Dec. 18, 1995.
- . “Election Checks Writing Relentlessly, Who Is Willing to Save the Government Budgeting.” Nov. 14, 1994.
- . “Editorial Review: Deterioration and Improvement on Government Budgeting.” Jan. 9, 1994.
- . “Editorial Review: How to Reduce Serious Deficits for Government Budgeting.” Sep. 18, 1993.
- . “Methods to Deal with Taiwan HSR Land Acquisition Problem.” July 24, 1993.
- . “Foreign Experiences: Governments Directed HSR Projects.” July 18, 1993.
- . “Gallup Poll Shows Over 80% Population Support HSR Project.” July 4, 1993.
- . “6-Year Plan Midterm Review: Allow More Detail and Open Discussion on Budgeting.” July 3, 1993.
- . “Minister of Ministry of Finance: 6-Year Plan’s Key Problem: Mistaken Finance Planning.” Apr. 20, 1993.
- . “French Teaches Japanese a Lesson.” May 7, 1991.

- . “Why Japanese Not Like French Approaching to Us.” Apr. 21, 1991.
- . “Benz Group Pushing German Politicians Visit Taiwan for Taiwan HSR Project.” Feb. 25, 1991.
- . “Everyday Topic: National Development Plan Not Necessary to Be Done in 6 Years.” Jan. 14, 1991.
- . “European Countries Playing Political Cards to Earn the 6-Year Plan.” Jan. 12, 1991.
- . “Germany Decides to Establish a Federal Office of Foreign Trade Information in Taiwan.” Jan. 7, 1991.
- . “Council of Economic Planning and Development (CEDP; CUSA previously) Agrees the Taiwan HSR Project.” Mar. 1, 1990.
- . “Economic Council Agrees to Build the Taiwan HSR: Might Privatize It in the Future.” Mar. 1, 1990.
- Edgerton, David E. H. “The Contradictions of Techno-Nationalism and Techno-Globalism: A Historical Perspective.” *New Global Studies* 1, 1 (2007): 1-32.
- . “From Innovation to Use: the Eclectic Theses on the Historiography of Technology.” *History and Technology* 16 (1999): 111-36.
- ed. *Industrial Research and Innovation in Business*. Cheltenham: Edward Elgar Publishing, 1996.
- Election Study Center, National Chengchi University.
<http://esc.nccu.edu.tw/modules/tinyd2/content/TaiwanChineseID.htm> (accessed on Mar. 3, 2010).
- Ellwanger, Gunther and Martin Wilckens. “High Speed for Europe.” *Japan Railway & Transport Review* 40 (1994): 17-25.

Escobar, Arturo. *Encountering Development: The Making and Unmaking of the Third World*.

Princeton, NJ: Princeton University Press, 1995.

Executive Yuan Gazette Database. <http://gazette.nat.gov.tw/egFront/index.jsp> (accessed on Mar. 26, 2010)

———. “About Executive Yuan: History and Mission.”

<http://www.ey.gov.tw/ct.asp?xItem=52758&ctNode=1327&mp=11> (accessed on Oct. 8, 2009).

Fang, Jun-yu (方俊育). *Technology or Politics: The Development of Vocational Industrial Education in Taiwan, 1945-1986*. Master thesis, National Tsing Hua University, 1990.

Fanon, Frantz. *The Wretched of the Earth*. NY: Grove, 1968.

———. *Black Skin, White Mask*. NY: Grove, 1967.

———, ed. *Nation and Narration*. London: Routledge, 1990.

Ferguson, James. *The Anti-Politics Machine: Development, Depoliticization, and Bureaucratic Power on Lesotho*. MN: University of Minnesota Press, 1994.

Fong, Chi-Chieh (馮智捷). “Public Investment Impacts on Private Economy in Taiwan (台灣公共投資對私部門經濟影響之研究).” Master thesis, National Taipei University, 2001.

Gonzalez-Savignat, Mar. “Competition in Air Transport: The Case of the High Speed Train.” *Journal of Transport Economics and Policy* 38, 1 (2004): 77-108.

Government Information Office. *The Republic of China Yearbook 2008*. Taipei: Government Information Office, 2008.

———. “Executive Yuan Secretary Clarifying Government Policy on THSR Finance.” *Premier Mailbox*, Nov. 22, 2004. <http://info.gio.gov.tw/ct.asp?xItem=20223&ctNode=1808> (accessed on Jan. 19, 2010).

- , ed. *President Teng-hui Lee 1993 Speech Selection*. Taipei: Government Information Office, 1994.
- Government Research Bulletin. <http://grbsearch.stpi.org.tw/GRB/quickSearch.jsp>
- Guigueno, Vincent. “Building a High-Speed Society: France and the Aerotrain, 1962-1974.” *Technology and Culture* 49 (2008): 21-40.
- Halfon, Saul. “The Disunity of Consensus: International Policy Coordination as Socio-Technical Practice.” *Social Studies of Science* 36 (2006): 783-807.
- Hård, Mikael. “German Regulation: The Integration of Modern Technology into National Culture.” In *The Intellectual Appropriation of Technology*, edited by Mikael Hård and Andrew Jamison, 33-68. MA: MIT Press, 1998.
- Hau, Pei-tsun. “Public Television Interview on Dec. 4, 1992.” In *Intrepidness*. Taipei: Wu-shi Publications, 1995.
- Headrick, Daniel R. *The Tentacles of Progress: Technology Transfer in the Age of Imperialism, 1850-1940*. NY: Oxford University Press, 1988.
- Hecht, Gabrielle. “Rupture-Talk in the Nuclear Age: Conjugating Colonial Power in Africa.” *Social Studies of Science* 32 (2002): 691-727.
- . “Technology, Politics, and National Identity in France.” In *Technology of Power: Essays in Honor of Thomas Parke Hughes and Agatha Chipley Hughes*, edited by Michael Thad Allen and Gabrielle Hecht, 253-294. Cambridge, MA: MIT Press, 2001.
- . *The Radiance of France: Nuclear Power and National Identity after World War II*. Cambridge, MA: MIT Press, 1998.
- Henckaerts, Jean-Marie ed. *The International Status of Taiwan in the New World Order: Legal and Political Considerations*. London: Kluwer Law International Ltd., 1996.

- Henders, Susan J., ed. *Democratization and Identity: Regimes and Ethnicity in East and Southeast Asia*. Lanham, MD: Lexington Books, 2004.
- Herf, Jeffery. *Reactionary Modernism: Technology, Culture, and Politics in Weimer and the Third Reich*. NY: Cambridge University Press, 1984.
- Hickey, Dennis Van Vranken. *Foreign Policy Making in Taiwan: From Principle to Pragmatism*. NY: Routledge, 2007.
- Ho, Nuan-Hsuan. "Taiwan HSR Will Create New Phases on City and Town Development." In *Taiwan Year Book 2005*. Taipei: CNA News, 2005.
- <http://www7.www.gov.tw/todaytw/2005/TWtaiwan/ch10/2-10-2-0.html> (accessed on Jan. 11, 2010).
- Hood, Christopher P. *Shinkansen: From Bullet Train to Symbol of Modern Japan*. NY: Routledge, 2006.
- Horowitz, Shale, Uk Heo, and Alexander C. Tan, ed. *Identity and Change in East Asian Conflicts: the Cases of China, Taiwan, and the Koreas*. NY: Palgrave Macmillan, 2007.
- Hsiao, Hsin-huang Michael. "Recapturing Taiwan's Democratization Experience." Keynote speech in the First Biennial Conference of World Forum for Democratization in Asia, Sep. 15~17, 2005. Download at <http://www.wfda.net/UserFiles/File/Hsiao.pdf>
- Hsu, I-Nan (徐亦南). "HSR Myth." *Taiwan Railways Journal* 260 (1989): 1-30.
- Hsu, Kanlin (許甘霖). "The Logic of Political Domination or the Logic of Market?: Rethinking 'Party-Owned Enterprise.'" *Taiwan: A Radical Quarterly in Social Studies* 28 (1997): 175-208.
- Hsu, Jun (許俊). "Archives of the Taiwan Railways Administration's Electrification Project, Part One." *Taiwan Railways Journal* 194 (1979): 78-88.

- Hsu, Ling (徐琳). "Review on the Taiwan HSR Construction Specifications." *Taiwan Railways Journal* 179 (1978): 1-9.
- Hsu, Shen-Long (許盛隆). "Mr. Tong Ping's Career: From Military to Engineering Service." *Journal of Chinese Engineers* (2004). www.c-km.org.tw/people/9312.pdf (accessed on Mar. 27, 2010).
- Hu, Hsian-Ling (胡湘麟). "The Case of Private Investment on Taiwan HSR Project." In *Proceedings of Rail Engineering Society of Taiwan (RESOT) Annual Meeting 2002*, 139-49. Taipei: RESOT, 2002.
- Huang, Chun-Chia (黃傳甲). "Study on Self-making Gas-locomotives." *Taiwan Railways Journal* 95 (1971): 1-17.
- Huang, Dong-Yi and Dow-Min Chung. "THSR Financial Controversy and Policy Agenda Setting." *Feng Chia Journal of Humanities and Social Sciences* 11 (2005): 281-309.
- Huang, Jun-Ming (黃俊銘). *A Journey of History of Taiwan Railways: Guides to Taiwan Railways Archives in Japanese Colonial Period and after the Second World War*. Taipei: National Archives Administration, 2009.
- Huang, Ming-Ren (黃民仁) ed. *History of Transport Engineering, Volume II: Railway Engineering*. Taipei: Chinese Institute of Civil and Hydraulic Engineering, 2008.
- Huang, Su (黃恕). "Strategies of Preventing Malfunction to Gas-locomotives." *Taiwan Railways Journal* 24 (1965): 1-18.
- . "Strategies of Preventing Malfunction to Gas-locomotives." *Taiwan Railways Journal* 25 (1965): 1-16.
- Huang, Tzu-Hwa (黃子華). "Teng-hui Lee's Political Thoughts and Policies." PhD diss., National Taiwan University, 2004.

- Hughes, Christopher. *Taiwan and Chinese Nationalism: National Identity and Status in International Society*. NY: Routledge, 1997.
- Hung, Yi-Jun (洪怡君). "The Effects of High Speed Rail Access Attributes on Intercity Travelers' Mode Choice Behavior." Master thesis, National Chi Nan University, 2005.
- Inkster, Ian. *Science and Technology in History: an Approach to Industrial Development*. NJ: Rutgers University Press, 1991.
- Institute of Transportation, Ministry of Transportation and Communications. "About IOT: Preface," <http://www.iot.gov.tw/english/ct.asp?xItem=380&CtNode=85> (accessed on Sep. 25, 2009).
- . *West Taiwan High Speed Rail Feasibility Study, Final Report*. Taipei: Institute of Transportation, 1990.
- . *Research Report of Constructing the HSR in Taiwan West Coast Corridor*. Taipei: Institute of Transportation, 1990.
- International Symposium on High Speed Railway Transport. *High Speed Rail Systems: Experience and Developments*. Taipei: SOFRERAIL Taipei Liaison Office, 1989.
- International Union of Railways. http://uic.asso.fr/spip.php?id_article=757&page=home (accessed on Nov. 19, 2009).
- Ishizuka, Masashi. "The Rolling Stock for Taiwan High Speed Rail." In *Proceedings of Rail Engineering Society of Taiwan (RESOT) Annual Meeting 2002*, 93-105. Taipei: RESOT, 2002.
- Jacobs, J. Bruce. "Taiwan's Colonial History and Postcolonial Nationalism." In *The "One China" Dilemma*, edited by Peter C. Y. Chow, 37-56. NY: Palgrave Macmillan, 2008.

- . “One China, Diplomatic Isolation and a Separate Taiwan.” In *China Rise, Taiwan's Dilemmas and International Peace*, edited by Edward Friedman, 85-109. NY: Routledge, 2006.
- . “Taiwanese and the Chinese Nationalists, 1937-1945: The Origins of Taiwan's Half-Mountain People (Banshan Ren).” *Modern China* 16, 1 (1990): 84-118.
- Jacoby, Neil. *U.S. Aid to Taiwan: a Study of Foreign Aid, Self-help, and Development*. NY: Praeger, 1966.
- Japan Airlines. “World Top 11 City-Pairs.” *SORA Data File*, 2004.
- Japan Railway Construction, Transport and Technology Agency. “English Content.” http://www.jrctt.go.jp/news/news_english.htm (accessed on Nov. 27, 2009).
- Japanese Industrial Standards Committee, <http://www.jisc.go.jp/eng/index.html> (accessed on Nov. 19, 2009).
- Japanese Ministry of Land, Infrastructure, Transport and Tourism. *Brochure of Ministry of Land, Infrastructure, Transport and Tourism*. <http://www.mlit.go.jp/common/000047294.pdf> (accessed on Nov. 27, 2009).
- Jasanoff, Sheila. “The Idiom of Co-production.” In *State of Knowledge: The Co-production of Science and Social Order*, edited by Sheila Jasanoff, 1-12. NY: Routledge, 2004.
- . “Ordering Knowledge, Ordering Society.” In *State of Knowledge: The Co-production of Science and Social Order*, edited by Sheila Jasanoff, 13-45. NY: Routledge, 2004.
- Kang, L. Sophia (康綠島). *K. T. Li Oral History: Talking Taiwan Experience*. Taipei: Excellence Publications & Printing Inc, 1993.
- Kao, Hsi-Junn (高希均). “6-Year Plan, a Necessary Surgery.” *Economic Daily*, Feb. 10, 1991.
- Kao, Lang (高朗). *The Evolution of Republic of China's Diplomatic Relations 1950~1972 (中華民國外交關係之演變: 一九五〇~一九七二)*. Taipei: Wunan Publication, 1993.

- . *The Evolution of Republic of China's Diplomatic Relations 1972~1992 (中華民國外交關係之演變: 一九七二~一九九二)*. Taipei: Wunan Publication, 1994.
- Kastner, Scott L. *Political Conflict and Economic Interdependence across the Taiwan Strait and Beyond*. Stanford, CA: Stanford University Press, 2009.
- Kim, Kwang Sik. "High-speed Rail Developments and Spatial Restructuring: a Case Study of the Capital Region in South Korea." *Cities* 17, 4 (2000): 251-62.
- Klien, Olivier. "Social Perception of Time, Distance and High-Speed Transportation." *Time and Society* 13 (2004): 245-63.
- Komagome, Takeshi. "Colonial Modernity for an Elite Taiwanese, Lim Bo-seng: The Labyrinth of Cosmopolitanism." In *Taiwan under Japanese Colonial Rule, 1845-1945: History, Culture, Memory*, edited by Liao Ping-Hui and David Der-Wei Wang, 141-59. NY: Columbia University Press, 2006.
- Kong, Shun-Ping (龔循平). *Visiting Report to Spanish and German Railway Industries*. Taipei: POHSR, 1995.
- Korea Transport Institute. *High Speed Rail and National Development*. Korea: The Korea Transport Institute, 1995.
- Kuomintang Central Committee of Design and Evaluation. *Introduction to the Taiwan Railways Administration Business, 1950-1955*. Taipei: Committee of the Kuomintang Railway Department, 1955.
- Lai, Jin-Po (賴金波). "Benefit Analysis on the 12 New." *Journal of Taipei Municipal Bank* 9: 12 (1978): 75-7.
- Lee, Bei-Tsun (李柏村). "Improvement Study on Track Electrical Communications, IV." *Taiwan Railways Journal* 53 (1967): 1-7.

- . “Improvement Study on Track Electrical Communications, III.” *Taiwan Railways Journal* 52 (1967): 1-13.
- . “Improvement Study on Track Electrical Communications, II.” *Taiwan Railways Journal* 51 (1967): 1-16.
- . “Improvement Study on Track Electrical Communications, I.” *Taiwan Railways Journal* 50 (1967): 1-13.
- Lee, Danny (李丹妮). “Taiwan Railways’ Taroko Express Launched in April.” *New Taiwan Weekly* 572 (2007).
- . “Adamant to Do IV&V for THSR Safety.” *New Taiwan Weekly* 554 (2006).
- Lee, Harvey Shui-Hong. *Assessment of Potential Aerodynamic Effects on Personnel and Equipment in Proximity to High-Speed Train Operations: Safety of High-Speed Ground Transportation Systems*. MA: U.S. Department of Transportation, Research and Special Programs, 1999.
- Lee, Teng-hui. *Witnessing Taiwan: Ching-Kuo Chiang and Me*. Taipei: Academia Historica, 2004.
- . *The Road to Democracy: Taiwan’s Pursuit of Identity*. Tokyo: PHP Institute Inc., 1999.
- . *With the People Always in My Heart*. Taipei: Yuan Liou Publishing Co., 1999.
- . *Managing Great Taiwan (經營大台灣)*. Taipei: Yuan Liou Publishing Co., 1995.
- and Mineo Nakajima (中嶋嶺雄). *Asia’s Intellectual Strategies (アジアの知略—日本は歴史と未来に自信を持て; 亞洲的智略)*, translated by Vincent Lo (駱文森) and Ming-Chu Yang (楊明珠). Taipei: Yuan Liou Publishing Co., 2000.
- and Yoshinori Kobayashi (小林善紀). *Teng-hui Lee School’s Wisdom (李登輝學校の教え; 李登輝學校的教誨)*, translated by Tze-Ying Yang (楊子瑩). Taipei: The Eurasia Publishing Group, 2001.

- Legislative Yuan. "Gazette Database." <http://lci.ly.gov.tw/> (accessed on Mar. 26, 2010).
- . "Concise History."
http://www.ly.gov.tw/ly/en/01_introduce/01_introduce_02.jsp?ItemNO=EN020000
(accessed on Jan. 5, 2010).
- . *Hightspeed Trains—Chinese Legislative News Review Series; V. 49*. Taipei: Legislative Yuan Library & Information Service, 1994.
- . *Legislative Yuan Important Days Volume 46: Second Legislative Yuan Section One and Two Year 1993*. Taipei: Legislative Yuan, 1994.
- Li, K. T. *The Evolution of Policy behind Taiwan's Development Success*. New Haven, CT: Yale University Press, 1988.
- Liao, Ching-Lung. "The Application of BOT Approach to Large Scale Infrastructure Projects—A Case Study of Taiwan High Speed Rail Project." *High Speed Rail News letter* 1: 22 (1997): 1-7.
- Liang, Kuo-Shu (梁國樹). *Kuo-Shu Liang's Economic Policy Recommendations 3: Taiwanese Economic Development Policy*. Taipei: Yuan Liou Publishing Co., 1998.
- Liberty Times*. "Japanese Intends to Control." Sep. 10, 2005.
- . "Nita Ing: Sorry for the THSR Delay." Sep. 9, 2005.
- . "MOTC Impugned the Japanese for THSR's Delay." Sep. 7, 2005.
- . "Fail to Vibration Test, the Taiwanese/Japan Track JV Not Allowed to Install Tracks Yet." Aug. 27, 2003.
- Lin, Chung-Hsiung (林鐘雄). *Taiwan's 40-Year Development Experience*. Taipei: Tzu-Li Nightly Publication, 1987.

- Liu, Chien-Hwa (劉建華). "The Review and Expectation on Taiwan Railways' Workforce Development." In *Century Memorial Collection on Taiwan Railways Administration*, edited by Jun-Ren So (壽俊仁), 410-3. Taipei: Taiwan Railways Administration, 1987.
- Liu, Chin-Ching (劉進慶). *Analyses on Taiwan's Economy after WWII (台灣戰後經濟分析)*. Taipei: Ren-Jen Publication, 1995.
- . *Diagnosing Taiwan: Economy in the Transformative Period (中日會診台灣: 轉型期的經濟)*. Edited by Masahiro Wakabayashi (若林正文) and translated by Yan-Hung Chen (陳艷紅). Taipei: Koo-Hsiang Publication, 1988.
- Liu, Su-Fen (劉素芬) ed. *K.T. Li: My Taiwan Experience—K.T. Li on Taiwan's Financial and Economic Policy Making and Thinking*. Taipei: Yuan Liou Publishing Co., 2005.
- Liu, Yu-shan (劉玉山). "Review on Infrastructure Projects with BOT Model (以 BOT 方式推動基礎建設之現況與未來)." In *Proceeding of the 1997 International Conference of Infrastructural Construction and BOT Planning (基礎建設與 BOT 計劃國際研討會)*, 1-11. Taipei: 1997.
- Lo, Ming-Cheng M. *Doctors within Borders: Profession, Ethnicity, and Modernity in Colonial Taiwan*. Berkeley, CA: University of California Press, 2002.
- Lu, Chen-Hui (呂正惠). *Scars of Colonies: the Problems of the Taiwanese Literature*. Taipei: Renjen Publications, 2002.
- Lu, Shei-Chen (盧協成), Tsun-Tzu Wang (王村竹) and Shih-Chun Wu (吳世傳). *Research Report on HSR Core System Manufacturing, Assembling, Maintenance and Quality Management*. Taipei: BOHSR, 2001.
- Lynch, Daniel C. *Rising China and Asian Democratization: Socialization to "Global Cultures" in the Political Transformations of Thailand, China, and Taiwan*. Stanford, CA: Stanford University Press, 2006.

- . “Refocusing the Taiwan Nationalists’ ‘Subjectivity Movement.’” In the Jamestown Foundation China Brief, 4 January 2005.
- Lynch, Thomas. *High Speed Rail in the U.S.: Super Trains for the Millennium*. Amsterdam, Netherlands: OPA 1998.
- Ma, Kai (馬凱). “Evolution of Taiwan Industrial Development Policy.” In *Proceedings on Taiwan Industrial Development*, edited by Kai Ma, 129-89. Taipei: Linking Publishing Co., 1976.
- Meunier, Jacob. *On the Fast Track: French Railway Modernization and the Origins of the TGV, 1944-1983*. Westport, CN: Praeger, 2002.
- Ministry of Transportation and Communication (MOTC). *Review on National Transportation Construction*. Taipei: MOTC, 1993.
- . *Six-Year National Development Plan: MOTC Part 1992-1997 (六年國建計畫: 交通部部分)*. Taipei: MOTC, 1992.
- . File Number: 0671010103/0005/0001/001, Dock Number: 67123348, Dec. 6, 1978.
- Mrázek, Rudolf. *Engineers of Happy Land: Technology and Nationalism in a Colony*. Princeton, NJ: Princeton University Press, 2002.
- . ““Let Us Become Radio Mechanics”: Technology and National Identity in Late-Colonial Netherlands East Indies.” *Comparative Studies in Society and History* 39 (1997): 3-33.
- Mutual Security. “U.S. Technological Aid Program.” *Industry of Free China* 5: 2 (1956): 21-3.
- Nagafuji, Takaharu (長藤敬晴). “Relative Merits of Ballast and Slab Track: Track Technology for High Speed Railways.” In *Proceedings of Workshop for High Speed Railways in Taiwan*. Taipei: BOHSR, 1997: 4-1~23.
- Nandy, Ashis. *The Illegitimacy of Nationalism: Rabindranath Tagore and the Politics of Self*. Delhi, India: Oxford University Press, 1994.

- . *The Intimate Enemy: Loss and Recovery of Self under Colonialism*. Bombay, India: Oxford University Press, 1983.
- , ed. *Science, Hegemony and Violence: A Requiem for Modernity*. Delhi, India: Oxford University Press, 1998.
- National Center for High-performance Computing. *Research Report on Micro Pressure Wave in HSR Tunnels*. Taipei: BOHSR, 1998.
- National Central Library Gazette Online. <http://gaz.ncl.edu.tw/>
- National Research Council, Transportation Research Board. *Railroads: High-speed Passenger Rail, Railway Bridges, and Track Design and Maintenance*. Washington D.C.: Transportation Research Board, 2004.
- . *New Ideas for High-speed Rail Systems: an Annual Progress Report of the High-Speed Rail IDEA Program*. Washington D.C.: Transportation Research Board, 2001.
- . *Railroad Research Topics: Costs of High-speed Rail, Communications-based Control and track Research*. Washington, D.C.: National Academy Press, 1997.
- . *Environmental Issues: Noise, Rail Noise, and High-speed Rail*. Washington, D.C.: National Academy Press, 1988.
- National Statistics, Republic of China (Taiwan). “Gross National Savings and Gross Domestic Investment.” <http://www.stat.gov.tw/ct.asp?xItem=15060&ctNode=3565> (accessed on Dec. 18, 2009).
- Navigating Electronic Agencies’ Records. https://near.archives.gov.tw/cgi-bin/near2/nph-redirect?rname=simp_search&
- Nawy, Edward G. *Prestressed Concrete: A Fundamental Approach*. Englewood Cliffs, NJ: Prentice Hall, 1989.

Nishiyama, Takashi. "Cross-Disciplinary Technology Transfer in Trans-World War II Japan: The Japanese High-Speed Bullet Train as a Case Study." *Contemporary Technology Transfer and Society* 1 (2003): 305-27.

Nownews. "THSR Traffic Control Center Exposed." Nov. 29, 2006.

Nye, David E. *America as Second Creation: Technology and Narratives of New Beginnings*. MA: The MIT Press, 2003.

Provisional Engineering Office of the BOHSR (POHSR), Ministry of Transportation and Communications. "POHSR Delegation Visits Investors, Bankers in Europe." *High Speed Rail Newsletter* 1: 10 (1996): 3.

———. "Presentation on HSR Project Held in Tokyo." *High Speed Rail Newsletter* 1: 10 (1996): 1.

———. "POHSR Delegations Visit France, Germany and Japan." *High Speed Rail Newsletter* 1: 9 (1996): 4.

———. "POHSR Briefs Japanese Companies." *High Speed Rail Newsletter* 1: 7 (1996): 1.

———. "Invitation to Tender on 'Legal Consultant Services' Announced." *High Speed Rail Newsletter* 1: 4 (1996): 6.

———. "Director General Holds Seminars in Europe." *High Speed Rail Newsletter* 1: 3 (1995): 1.

———. "Exploring the Methods and Obstacles of Domestic Funding for the HSR Construction." *High Speed Rail Newsletter* 1: 2 (1995): 5.

———. "General Engineering Consultant Tender." *High Speed Rail Newsletter* 1: 2 (1995): 3.

———. "Preparation of BOT Tender for HSR Project." *High Speed Rail Newsletter* 1: 2 (1995): 1-3.

———. "Promotion of HSR Privatization Program." *High Speed Rail Newsletter* 1: 2 (1995): 2.

———. "Preparation of BOT Tender for HSR Project." *High Speed Rail Newsletter* 1: 2 (1995): 1.

- . “Innovative Land Development Program under Study.” *High Speed Rail Newsletter* 1: 1 (1995): 8.
- . “Exploring New Incentives for Land Owners along the HSR Route.” *High Speed Rail Newsletter* 1: 1 (1995): 7.
- . “Tendering of Financial Consultant Services to the High Speed Rail Project.” *High Speed Rail Newsletter* 1: 1 (1995): 5.
- . “Progress on the Preparation of Build-Operate-Transfer Tender.” *High Speed Rail Newsletter* 1: 1 (1995): 4.
- . ““Land Acquisition Seminars Moving Forward HSR Project.” *High Speed Rail Newsletter* 1: 1 (1995): 3.
- . “Progress on the Enactment of the Encouragement Statute’s By-laws.” *High Speed Rail Newsletter* 1: 1 (1995): 2.
- . *Engineering Plan for the High Speed Railway on the West Taiwan Corridor*. Taipei: POHSR, 1994.
- . *West Taiwan Corridor HSR Construction Plan*. Taipei: POHSR, 1994.
- . *Taiwan HSR Construction Plan*. Taipei: POHSR, 1993.
- . *Intern Report on French and German HSRs’ Civil Engineering*. Taipei: POHSR, 1993.
- . *Research Report on French and German HSR Mechanical Engineering*. Taipei: POHSR, 1991.
- . *Intern Report on HSR Electrical System Engineering*. Taipei: POHSR, 1991.
- . *West Taiwan High Speed Rail General Planning, Final Report*. Taipei: POHSR, 1991.
- . *Visiting Report on the German and French HSRs*. Taipei: POHSR, 1990.
- . *Environmental Impact Report on the THSR*. Taipei: POHSR, 1992.

- . “Introduction to West Taiwan Collider HSR Construction Plan.” *Taiwan Railways Journal* 267 (1991): 1-22.
- . *HSR Electrical Affairs Intern Report*. Taipei: POHSR, 1991.
- . *General Planning Report on the THSR and Developments of the Taiwan Western Coast Corridor, Volume I and II*. Taipei: POHSR, 1991.
- . *High Speed Rail Newsletter*. Taipei: POHSR, 1995~1997.
- Office of Taiwan Governor-General (台灣省行政長官公署) ed. *Fifty-one Years of Taiwan's Statistics (臺灣省五十一年來統計提要)*. Taipei: Office of Taiwan Governor-General, 1946.
- Official Publication Echo Network. http://open.nat.gov.tw/OpenFront/report/report_main.jsp
- Philip, Kavita. “Imperial Science Rescues a Tree: Global Botanic Networks, Local Knowledge and the Transcontinental Transplantation of Cinchona.” *Environment and History* 1 (1995): 173-200.
- Phillips, Steven E. *Between Assimilation and Independence: The Taiwanese Encounter Nationalist China, 1945-1950*. Stanford, CA: Stanford University Press, 2003.
- Prakash, Gyan. *Another Reason: Science and the Imagination of Modern India*. Princeton, NJ: Princeton University Press, 1999.
- RAIL.ONE. *RHEDA 2000: the Ballastless Track with Concrete Supporting Layer*
http://www.railone.com/fileadmin/dateien/03_Broschueren/EN/rheda_2000_en.pdf
- Railway Reconstruction Bureau. *Visiting Report on HSR, Channel Tunnel and Mountain Tunnels*. Taipei: Railway Reconstruction Bureau, 1992.
- . *Railway Reconstruction, Visiting Report on the Japanese Shinkansen: Planning, Design, Build and Operation*. Taipei: Railway Reconstruction Bureau, 1990.
- Redfield, Peter. “The Half-Life of Empire in Outer Space.” *Social Studies of Science* 32 (2002): 791-825.

- Rigge, Shelley. "Party Politics and Taiwan's External Relations." *Orbis* 49 (2005): 413-28.
- . "Social Science and National Identity: a ritique." *Pacific Affairs* 72, 4 (1999): 537-52.
- Sasaki, Komei, Tadahiro Ohashi and Asao Ando. "High-Speed Rail Transit Impact on Regional Systems: Does the Shinkansen Contribute to Dispersion?." *Transport infrastructure* (2002): 590-611.
- Shiao, Chyuan-jenq (蕭全政). "Political-economic Meanings of the Six-Year National Development Plan." In *Taiwan's New Thinking: Nationalism*. Taipei: Shi-ying Publishing, 1995.
- Simoes, Goncalo Medeiros Pais. "RAMS analysis of railway track infrastructure." Master thesis, Instituto Superior Técnico, Lisboa, Portugal, 2008.
- Simon, Denis Fred. "Charting Taiwan's Technological Future: the Impact of Globalization and Regionalization." *The China Quarterly* 148 (1996): 1196-223.
- Simon, Thomas W. and A. Emerson Wiens. "Narratives of Technology Transfer." *Bulletin of Science, Technology and Society* 13 (1993): 63-6.
- So, Jun-Ren (壽俊仁) ed. *Century Memorial Collection on Taiwan Railways Administration*. Taipei: Taiwan Railways Administration, 1987.
- Sovacool, Benjamin and Saul Halfon. "Reconstructing Iraq: Merging Discourses of Security and Development." *Review of International Studies* 33 (2007): 223-43.
- Staudenmaier, John M. "Recent Trends in the History of Technology." *American Historical Review* 95 (1990): 715~25.
- Strohl, Mitchell P. *Europe's High Speed Trains: a Study in Geo-economics*. Westport, CT: Praeger, 1993.
- Su, Chi. *Taiwan's Relations with Mainland China: a Tail Wagging Two Dogs*. New York, NY: Routledge, 2009.

- Su, Shiao-chian (蘇曉倩). "Body and Education: Body Discipline in Vocational School in Taiwan Under Japanese Colonial Rule, 1919-1945." Master thesis, National Chi Nan University, 2003.
- Sumiya, Mikio (隅谷三喜郎), Chin-Ching Liu (劉進慶) and Tsao-Yan Tu (涂照彥). *Taiwan's Economy: Typical NIES Achievements and Problems (台灣之經濟—典型NIES之成就與問題)*. Translated by Hui-Ying Ray (雷慧英). Taipei: Ren-Jen Publication, 1993.
- Sun, Chung-Ho (孫中和). "Taiwan Railways' Step into Modernization" In *Century Memorial Collection on Taiwan Railways Administration*, , edited by Jun-Ren So (壽俊仁), 315-25. Taipei: Taiwan Railways Administration, 1987.
- Taiwan Area National Expressway Engineering Bureau. <http://gip.taneeb.gov.tw/> (accessed on Mar. 26, 2010).
- Taiwan Daily*. "MOTC Seeking Jpn Help." Apr. 26, 2006.
- Taiwan High Speed Rail Company. *2008 Annual Report*.
http://www.thsrc.com.tw/tc/about/ab_stock_download.asp (accessed on Mar. 36, 2010).
- . *THSRC 2008 Annual Financial Report*. Taiwan Market Observation Post System,
http://emops.twse.com.tw/emops_all.htm (accessed on Dec. 4, 2009).
- Taiwan Next Magazine*. "Jpn Pro: Ing Building Dangerous THSR." Dec. 2, 2004.
- Taiwan Railways Administration. "Route Kilometers."
<http://www.railway.gov.tw/en/yearbook/yearbook-4.aspx> (accessed on Mar. 36, 2010)
- . "Important Events in 2006." <http://www.railway.gov.tw/intro/introduction-3-3.aspx>
 (accessed on Mar. 8, 2010).
- . *Visiting Report on French, German, South Africa and Hong Kong Railways*. Taipei: Taiwan Railways Administration, 1989.

- . *Centurial History of Chinese Railway Construction*. Taipei: Taiwan Railways Administration, 1981.
- . *The Year-1978 Work Report of the Research Project on the Development of Constructing Super Railway*. Taipei: Taiwan Railways Administration, 1978.
- . *General Report of the Electrification for the West Truck Line*. Taipei: Taiwan Railways Administration, 1979.
- . *The Year-1978 Work Report of the Research Project on the Development of Constructing Super Railway, Volume I*. Taipei: Taiwan Railways Administration, 1978.
- . *The Year-1978 Work Report of the Research Project on the Development of Constructing Super Railway, Volume II*. Taipei: Taiwan Railways Administration, 1978.
- . *Introduction to Taiwan Railways Administration*. Taipei: Taiwan Railways, 1977.
- . *The Year-1976 Work Report of the Research Project on the Development of Constructing Super Railway, Volume I*. Taipei: Taiwan Railways Administration, 1976.
- . *The Year-1976 Work Report of the Research Project on the Development of Constructing Super Railway, Volume II*. Taipei: Taiwan Railways Administration, 1976.
- . “Outline of the Progress of the Railway Electrification Engineering.” *Engineering (工程)* (1975): 564-565.
- . *The Year-1975 Work Report of the Research Project on the Development of Constructing Super Railway, Volume I*. Taipei: Taiwan Railways Administration, 1975.
- . *The Year-1975 Work Report of the Research Project on the Development of Constructing Super Railway, Volume II*. Taipei: Taiwan Railways Administration, 1975.
- . *Taiwan Railways Journal*. Taipei: Taiwan Railways Administration, 1963~.
- Taiwan Railways Online Museum Website. “Diesel Electricity Locomotives.”
<http://www.railway.gov.tw/museum/train/train02.htm> (accessed on Mar. 8, 10.)

- Taiwan Railways Research Team. "Research Report on Self-making Electric-locomotive Accessories, I." *Taiwan Railways Journal* 230 (1983): 1-7.
- . "Research Report on Self-making Electric-locomotive Accessories, II." *Taiwan Railways Journal* 231 (1983): 1-11.
- Taiwan Shin Sheng Daily News*. "Local THSR Conductors Begin to Serve." May 24, 2007.
- Takaji, Ryo. "High-speed Railways: the Last Ten Years." *Japan Railway & Transport Review* 40 (2005): 4-9.
- Tanaka, Hiroyoshi (田中昌宏). "THSR's Current Situation and Issues (台湾高速鉄道プロジェクトの現況)." *Journal of Japan's Railway Engineers' Association* 47: 10 (2004).
- Tang, Tien-Chen (湯天成). "Improvement Study on GEC 100 MUT Motors." *Taiwan Railways Journal* 275 (1983): 65-75.
- Tang, Xiaobing. "On the Concept of Taiwan Literature." *Modern China* 25, 4 (1999): 379~422.
- Taylor, Jay. *The Generalissimo's Son: Chiang Ching-Kuo and the Revolution in China and Taiwan*. Cambridge, MA: Harvard University Press, 2000.
- Tien, De-Jen (田德儉). "Engine Functional Trials on Hitachi R0 and R1 Gas-Locomotives." *Taiwan Railways Journal* 31 (1966): 42-50.
- Times*, "Strait Talk: The Full Interview." Feb. 16, 2004.
- <http://www.time.com/time/world/article/0,8599,591376-2,00.html> (accessed on Jan. 8, 2010).
- Tony Gee and Partners. "Taiwan High Speed Link."
- <http://www.tgp.co.uk/services/projects/taiwan.html> (accessed on Nov. 27, 2009).
- Tsai, Long-Bao (蔡龍保). *Taiwan's National Railroad in Mid-Japanese Colonial Period, 1910-1936*. Taipei: Taiwan Bookstore Publications, 2007.

- Tsai, Shih-Shan Henry. *Lee Teng-hui and Taiwan's Quest for Identity*. NY: Palgrave Macmillan, 2005.
- Tseng, Chung-Yeh (曾瓊葉) ed. *The Vietnam War: An Oral History (越戰回憶錄)*. Taipei: Ministry of Defense Office of History, 2008.
- Tsuei, Bol-Yi. "Review and Prospectus After THSR Open to Traffic" *Engineering (工程)* 81 (2008): 31~46.
- Tsurumi, E. Patricia. *Japanese Colonial Education in Taiwan, 1895-1945*. MA: Harvard University Press, 1977.
- Tung, Chien-Hung. "The THSR Business Operation and the Aspiration of Modernization in the Taiwanese Society." *Contemporary Monthly (當代)* 239 (2007): 86-99.
- . "Planning in a Democratized Domain: Democratization and Planning Bureaucracy in Taiwan." PhD diss., Columbia University, 2006.
- Tung, Ming-Ray (董民瑞). "Supplement Report Two on Alternating 'R1' Power Equipments." *Taiwan Railways Journal* 115 (1973): 98-108.
- . "Supplement Report One on Alternating 'R1' Power Equipments." *Taiwan Railways Journal* 114 (1973): 84-91.
- . "Special Report Two: Engineering Redesign and Practice on Hitachi Diesel-Electric Locomotives, II." *Taiwan Railways Journal* 107 (1972): 1-19.
- . "Special Report One: Engineering Redesign and Practice on Hitachi Diesel-Electric Locomotives, I." *Taiwan Railways Journal* 106 (1972): 1-29.
- Tzu-Li Daily* (自立早報). "Special Report for County Major Election 1993." Sep. 21, 1993.
- Tzu-Li Nightly* (自立晚報). "Government Should Plan Important Infrastructure Built on Public Land." May 27, 1993.

- U.S. Dept. of Transportation, Federal Railroad Administration, Office of Research and Development. *Safety of High Speed Guided Ground Transportation Systems: Magnetic and Electric Field Testing of the French Train a Grande Vitesse (TGV) Rail Systems*. Springfield, VA: National Technical Information Service, 1993.
- United Daily*. “Chin-Der Ou (歐晉德; CEO of the THSRC): Foreign Vice General Managers Deigned.” Sep. 25, 2009.
- . “Ing Stepped Down, Ou Becomes THSRC President.” Sep. 23, 2009.
- . “THSR Conductor Violated Duty Discipline in Operation,” Mar. 25, 2009.
- . “THSR Booking System Hacked,” Jan. 6, 2008.
- . “How much Money and How Many Politicians Wasted Due to Lowering Vibration Project,” Dec. 26, 2006.
- . “Prosecutor Questions the Vibration Case over Spending,” Oct. 14, 2006.
- . “President Chen to Visit African Friends in Sep.” July 4, 2006.
- . “Vibration Case Indicted,” May 17, 2006.
- . “BOHSR: Hardly Launch in October 2006.” May 3, 2006.
- <http://www.iot.gov.tw/ct.asp?xItem=147452&CtNode=1066> (accessed on Nov. 30, 2009).
- . “Taiwanese and Japanese Gov’ts Help the THSRC.” Oct. 1, 2005.
- . “Delay Due to Core System Work Serious Behind.” Sep. 9, 2005.
- . “MOTC Favor Japanese: Okay with THSR Core System Following Jpn Design.” Mar. 18, 2005.
- . “Iwasato Masao (Lee’s Japanese name during the Japanese colonial period; 岩里政男) in Japan.” Dec. 29, 2004.
- . “Japan Professionals: Problems of the Euro-Jpn Hybrid THSR.” Nov. 28, 2004.

- . “Business Negotiation 3 More Years: THSRC Required to Compensate Eurotrain 24 NTD.” Mar. 16, 2004.
- . “THSRC Taipei to Banciao Construction Behind.” Aug. 23, 2003.
- . “THSRC Negotiates with Eurotrain for Compensation.” Apr. 2, 2002.
- . “DPP Legislator Chen Chao-Nan (陳昭南): Euro-Jpn Battle Fire Spreading.” May 9, 2001.
- . “Executive Yuan Discusses THSR Vibration Case,” Feb. 24, 2001.
- . “Member Selection of Chen’s National Consulting Committee.” Apr. 3, 2000.
- . “Japan Economic Times: Lee’s Japan Visit Raises Controversy in Liberal Democratic Party (日本自民黨).” Mar. 27, 2000.
- . “Syndicate Loan to HSR Project Settled, HSR Construction Begins 6 Months Later.” Feb. 3, 2000.
- . “French, German and British Representatives in Taiwan Concern Core System Bidding.” Jan. 26, 2000.
- . “Ing: Eurotrain too Confident to Lose.” Jan. 7, 2000.
- . “Something Needs to be Checked.” Dec. 30, 1999.
- . “Politics Mattered? Some Recent Events with the Japanese Politicians.” Dec. 29, 1999.
- . “Japanese Press Reports THSR Expected to Adopt Shinkansen before Result Coming Out.” Dec. 18, 1999.
- . “Postpone THSRC Financial Problem after Presidential Election.” Aug. 15, 1999.
- . “Jpn or Euro Core HSR System: Which fits Taiwan’s Most Needs.” June 28, 1999.
- . “Final Count Down on Core System Tender.” May 26, 1999.
- . “THSR Marriage: Create a Win-Win Scenario for Government and People with BOT Model.” July 26, 1998.
- . “HSR BOT Contract Signed: Open to Traffic by 2003.” July 24, 1998.

- . “Ing Interview: Government Intervention and Threat in Negotiation Process.” July 3, 1998.
- . “China Development Manage General: We Do not Exclude to Join.” July 3, 1998.
- . “What’s Wrong the Contract Signing.” July 3, 1998.
- . “HSR BOT Contract Negotiation Troubling: THSRC Might Refuse and China Development Might Substitute.” July 2, 1998.
- . “Ministry of Finance Minister: BOT Project No Exceptional to General Bank Laws and Regulations.” Jan. 17, 1998.
- . “BOHSR: Loaning Progress Could Cause to Serious Catastrophe to THSR.” Jan. 16, 1998.
- . “German Locomotives Pull and Push French Trains: THSR Rolling Stock Tested Successfully.” May 5, 1998.
- . “Editorial Colum: HSR Project Review.” Sep. 27, 1997.
- . “THSRC: Finish By 2003, Challenging but Confident.” Sep. 26, 1997.
- . “HSR Project Changing Taiwan Business.” Sep. 25, 1997.
- . “MOTC Wants Ching-Lung Liao to Take Over.” on Aug. 13, 1996.
- . “New MOTC Policy: Core System Prior to Civil Planning.” June 28, 1996.
- . “Ministry of Finance Minister: Congressmen Do Not Give People Illusions Please.” Mar. 6, 1995.
- . “Congressmen Should Take More National Responsibilities.” May 2, 1995.
- . “12 Plans Cost 2,500 Billion NTD: Pick Core Projects in 6-Year Plan and Encourage Private Sector Participation to Alleviate Budget Pressure.” Jan. 11, 1994.
- . “Hau’s Political Journey.” July 17, 1993.
- . “MOTC Commission Gallup Poll Mostly Pro HSR Project.” July 3, 1993.
- . “Review 6-Year Plan Especially Transportation Project: Lack of Detail Plans.” Mar. 8, 1993.

- . “Five County Mayors Against HSR Planning Policy Change.” June 24, 1991.
- . “Important Transport Construction Planning Should be Made Top-down.” June 23, 1991.
- . “Hau: HSR Planning Design from Viewpoints of National Planning and New City-town Development.” June 22, 1991.
- . “Five Principles on Mainland China Policy; J. Song, KMT Secretary-General: Unity, Reality, Security, Reciprocity and Graduality.” June 13, 1991.
- . “CEDP V.S. MOF for Money.” June 5, 1991.
- . “Ministry of Finance Fights with Economic Council on the 6-Year Plan’s Budget.” June 5, 1991.
- . “Wang (王建煊; Minister of Ministry of Finance): No Money Fact, HSR for Private Investments.” June 5, 1991.
- . “Hau: We Must Build Taiwan HSR.” June 4, 1991.
- . “Wang, Minister of Ministry of Finance: No Money is a Fact.” June, 4, 1991.
- . “Chien (簡又新; Minister of MOTC): Money First for All Transport Constructions.” May 30, 1991.
- . “Lee-Hau One-Year Inauguration: On Economic and Financial Policies.” May 20, 1991.
- . “*Temporary Provisions Terminated, Peaceful Approach to Union.*” Mar. 13, 1991.
- . “No Change Our Fundamental Policy, Only Union Policy Changed.” May 2, 1991.
- . “Hau Directed Cabinet Personnel Arrangement.” May 30, 1990.
- . “Wang Appointment Undermined Lee’s Plan.” May 30, 1990.
- . “Re-claim Control over Mainland China: From Military Force to Political Means, Now the Time.” June 21, 1989.
- . “Editorial: Chiang Announced 12 New after Ten Major Completion.” Sep. 24, 1977.
- United Nightly.* “Eurotrain Might Ask for Compensation.” Dec. 29, 1999.

- . “Re-planning the Taiwan HSR, MOTC Minister: No Waste.” June 22, 1991.
- . “Hau Repeat: Money Not a Problem to 6-Year Plan.” June 7, 1991.
- . “First Time, a French Minister Will Join the Republic of China-France Economic Cooperation Conference.” Jan. 7, 1991.
- Van Wee, Bert, Robert van den Brink and Hans Nijland. “Environmental Impacts of High-Speed Rail Links in Cost-Benefit Analyses: A Case Study of the Dutch Zuider Zee Line.” *Transportation Research: Part D: Transport and Environment* 8, 4 (2003): 299-314.
- Wakabayashi, Masahiro. “A Perspective on Studies of Taiwanese Political History: Reconsidering the Postwar Japanese Historiography of Japanese Colonial Rule in Taiwan.” In *Taiwan under Japanese Colonial Rule, 1845-1945: History, Culture, Memory*, edited by Liao Ping-Hui and David Der-Wei Wang, 19-39. NY: Columbia University Press, 2006.
- Wang, Bao-Lin (王寶林). “Our Mission (我等の任務).” *Alumni Magazine the Taipei State Industrial School Alumni Association* 18 (1939): 156-7.
- Wang, Fu-Chang. “‘Why Did the DPP Win Taiwan’s 2004 Presidential Election?: An Ethnic Politics Interpretation,’ Domestic and International Considerations of Taiwan’s 2004 Presidential Election: An Interdisciplinary Roundtable.” *Pacific Affairs* 77 (2005): 691-6.
- Wang, Jenn-Hwan (王振寰). *Who Governs Taiwan? State Machine and Power Structure in Transformation* (誰統治台灣? 轉型中的國家機器與權力結構). Taipei: Liwen Publisher, 1996.
- . “New Political and Business Relationship and Political Transformation in Taiwan.” *Taiwan: A Radical Quarterly in Social Studies* 14 (1993): 123~63.
- Wang, Qih-Chang (王其昌) and Qih-Meng Han (韓啓孟) ed. and trans. *Slab Track Design and Build*. Chengdu, Sichuan: Southwest Jiaotong University, 2002.

- Wang, Shan-Shan (王珊珊). *Modern Taiwan Conventional Rail and Cargo Transportation, 1887-1935*. Hsinchu, Taiwan: Bureau of Cultural Affairs, Hsinchu County Government, 2004.
- Wang, Shi-I (王世一). "Accessories Self-making for Gas-locomotives." *Taiwan Railways Journal* 60 (1968): 1-20.
- Watanabe, Keinoshin (渡部慶之進). *A Review on Taiwan's Railroad*. Nantou, Taiwan: Taiwan Historica, 2006.
- Wei, Duan (韋端). "Six-Year National Development Plan: Hard but Favored." *Commonwealth Magazine* 117 (1991): 58-9.
- Wen, Bei-Chang (溫蓓章). "Detouring High Speed Rail in Taiwan: State Transformation and Transportation Planning." PhD diss., National Taiwan University, 2000.
- Winner, Langdon. *Autonomous Technology: Technics-out-of-Control as a Theme in Political Thought*. MA: The MIT Press, 1977.
- . "Do Artifacts Have Politics?" In *The Social Shaping of Technology*, edited by Donald A. MacKenzie, 28-40. PA: Open University Press, 1986.
- Wu, Chengqiu. "The Discursive Construction of Taiwanese National Identity." PhD diss., Virginia Polytechnic Institute and State University, 2007.
- . "Peace or War in the Taiwan Strait: a Game Theoretical Analysis of the Taiwan Issue." Master thesis, Virginia Polytechnic Institute and State University, 2003.
- Wu, Chyuan-Yuan. "Sustainable Development in Taiwan: Science and Democracy in the Anti-Incinerator Movement." *Bulletin for Global Change* 38 (2003): 44-50.
- . "Technology and the Study of Technology in Taiwan." *Contemporary Monthly* (當代) 176 (2002): 64-73.

- Wu, Fu-Hsiang. "THSR New Records." In *Proceedings of the Fifth Cross-straight Tunnel and Underground Engineering and Technology Conference*. Taipei: Chinese Taipei Tunneling Association, 2006.
- Wu, Rwei-Ren. "The Formosan Ideology: Japan's Oriental Colonialism and the Rise of Taiwanese Nationalism, 1895-1945." PhD diss., University of Chicago, 2003.
- Wu, Song-Tzoo (吳松竹). "Independent Checking, Verification and Validation." In *Proceedings of Rail Engineering Society of Taiwan (RESOT) Annual Meeting 2002*, 186~192. Taipei: RESOT, 2002.
- Wu, Tsao-Yi (吳昭儀). "Behind the THSR Controversy." *Common Wealth* 320 (2005): 168-74.
- Wu, Tsong-Min (吳聰敏). "U.S. Aid and Taiwan's Economic Development." *Taiwan: A Radical Quarterly in Social Studies* 1:1 (1988): 145-58.
- Wu, Wan-Yu (吳琬瑜) and Tsao-Yi Wu (吳昭怡). "Nita Ing: the THSR should be De-Inginized." *Common Wealth* 368 (2007): 55-9.
- Yang, Li-Yu (楊力宇). *A New Taiwan and a New Era: Lien Chan's Contribution and Dedication*. Taipei: Liu Chung Publication, 2000.
- Yao, Jen-to. "The Japanese Colonial State and Its form of Knowledge in Taiwan." In *Taiwan under Japanese Colonial Rule, 1845-1945: History, Culture, Memory*, edited by Ping-Hui Liao and David Der-Wei Wang, 37-61. NY: Columbia University Press, 2006.
- Yeh, Won-Ahn (葉萬安). "Taiwan's Economic Plan." In *The Taiwan Experience: 1949~1989*, edited by H. C. Kao and Joseph S. Lee, 46-75. Taipei: Commonwealth Publishing, 1993.
- Yoo, Sun-young. "Embodiment of American Modernity in Colonial Korea." *Inter-Asia Cultural Studies: Movements* 2 (2001): 423-42
- Yoshimi, Shunya. "'America' as Desire and Violence: Americanization in Postwar Japan and Asia during the Cold War." *Inter-Asia Cultural Studies: Movements* 4 (2003): 433-50.

———. “‘America’ in Contemporary Japan: From Symbol to System.” In *Consumption in Asia: Lifestyles and Identities*, edited by Chua Beng Huat. London: Routledge, 2000.

Zaidi, Kamaal R. “High Speed Rail Transit: Developing the Case for Alternative Transportation Schemes in the Context of Innovative and Sustainable Global Transportation Law and Policy.” *Temple Journal of Science, Technology & Environmental Law* 301 (2007): 301-47.

APPENDIX: INTERVIEW LIST

Name	Interview Date	Interview Place	Position	Section/Department	Division	Institute/Company/Association
KL	Nov. 31, 08	Taipei	Engineer			CECI Engineering Consultant, Inc., Taiwan
Lee-in Chen Chiu 陳麗瑛	Dec. 10, 08	Taipei	Policy Advisor	Her deceased husband, Jin-Shien Chiu (邱錦祥), was the former Secretary General of BOHSR		Chung-Hwa Institute for Economic Research
Ping Tong 董萍	Dec. 11, 08	Taipei	Former Director General (from July 2, 1990 to Sep. 1, 1991)*			BOHSR, MOTC
CW	Dec. 15, 08	Taipei	Engineer	Procurement Section, Procurement Dept.	Construction Management & Procurement	THSRC
SY	Dec. 22, 08	Taipei	Engineering Director	Core System Dept., System Zone	Construction Management Division	THSRC
YW	Dec. 25, 08	Kaohsiung	Assistant Manager	OCS & Power Maintenance Section, Permanent Way Maintenance	Maintenance Sub-Division	THSRC

Name	Interview Date	Interview Place	Position	Section/Department	Division	Institute/Company/Association
				Dept.		
DK	Dec. 31, 08	Taipei	Engineer	Maintenance Depot Dept.	Maintenance Sub-Division, Maintenance Management Division	THSRC
AL	Jan. 2, 09	Taipei	Specialist	Trackwork Construction Section	Construction Sub-Division, Construction Management Division	THSRC
RW	Jan. 5, 09	Taichung	Senior Manager (Director of Wurih Depot Section)	Wurih Depot Section, Depot Management Dept.	Maintenance Sub-Division	THSRC
Bol-Yi Tsuei 崔伯義	Jan. 6, 09	Taipei	Vice President			CECI Engineering Consultant, Inc., Taiwan
RL	Jan. 6, 09	Taichung	BS Supervisor	Taichung Station, Passenger Services Dept.	Operation Sub-Division	THSRC
JL	Jan. 6, 09	Taichung	BS Supervisor	Taichung Station, Passenger Services Dept.	Operation Sub-Division	THSRC

Name	Interview Date	Interview Place	Position	Section/Department	Division	Institute/Company/Association
Chin-Long Liao 廖慶隆	Jan. 7, 09	Taipei	President (former Director General of BOHSR from Aug. 20, 1996 to July 24, 2002)*			CECI Engineering Consultant, Inc., Taiwan
VY	Jan. 7, 09	Hsinchu	Assistant Manager (Director of Lioujia Depot Section)	Lioujia Depot Section, Depot Management Dept.	Maintenance Sub-Division	THSRC
RY	Jan. 8, 09	Kaohsiung	Assistant Director	Zuoying Depot Section, Rolling Stock Maintenance Dept.	Maintenance Sub-Division	THSRC
Fred P. C. Huang 黃博治	July 29, 09	Taipei	Honor Chairman			Taiwan Association of Machinery Industry; Tokyo University Alumni Association
Ruey-Nian Tsau 卓瑞年	Aug. 11, 09	Taipei	Former Director General			Sinotech Engineering Consultants, LTD.
Ming-Ren Huang 黃民仁	Aug. 31, 09	Taipei	Deputy Director General			Taiwan Railways Administration
Kai-Hsi Lee 李開熙	Oct. 15, 09	Taipei	Section Chief	Rolling Stock	Electrical and Mechanical Division	BOHSR, MOTC
Fu-Hsiang Wu	Nov. 3, 09	Hsinchu	Dean, College of Architecture and Planning (Former Director General of BOHSR from Aug. 29, 2005 to			Chung Hwa University

Name	Interview Date	Interview Place	Position	Section/Department	Division	Institute/Company/Association
吳福祥			Jan. 1, 2007)*			
Daniel H. Ju 朱旭	Nov. 6, 09	Taipei	Director General (from Nov. 3, 08 to the present)*			BOHSR, MOTC
Yung-Hsiang Chen 陳永祥	Nov. 9, 09	Taipei	Member of the Control Yuan (former Dean of College of Engineering at National Taiwan University)			Control Yuan

* See more detail at BOHSR, "Highlight," <http://www.hsr.gov.tw/homepage.nsf/homepage-eng?OpenFrameset>