

Better Kitchen Storage

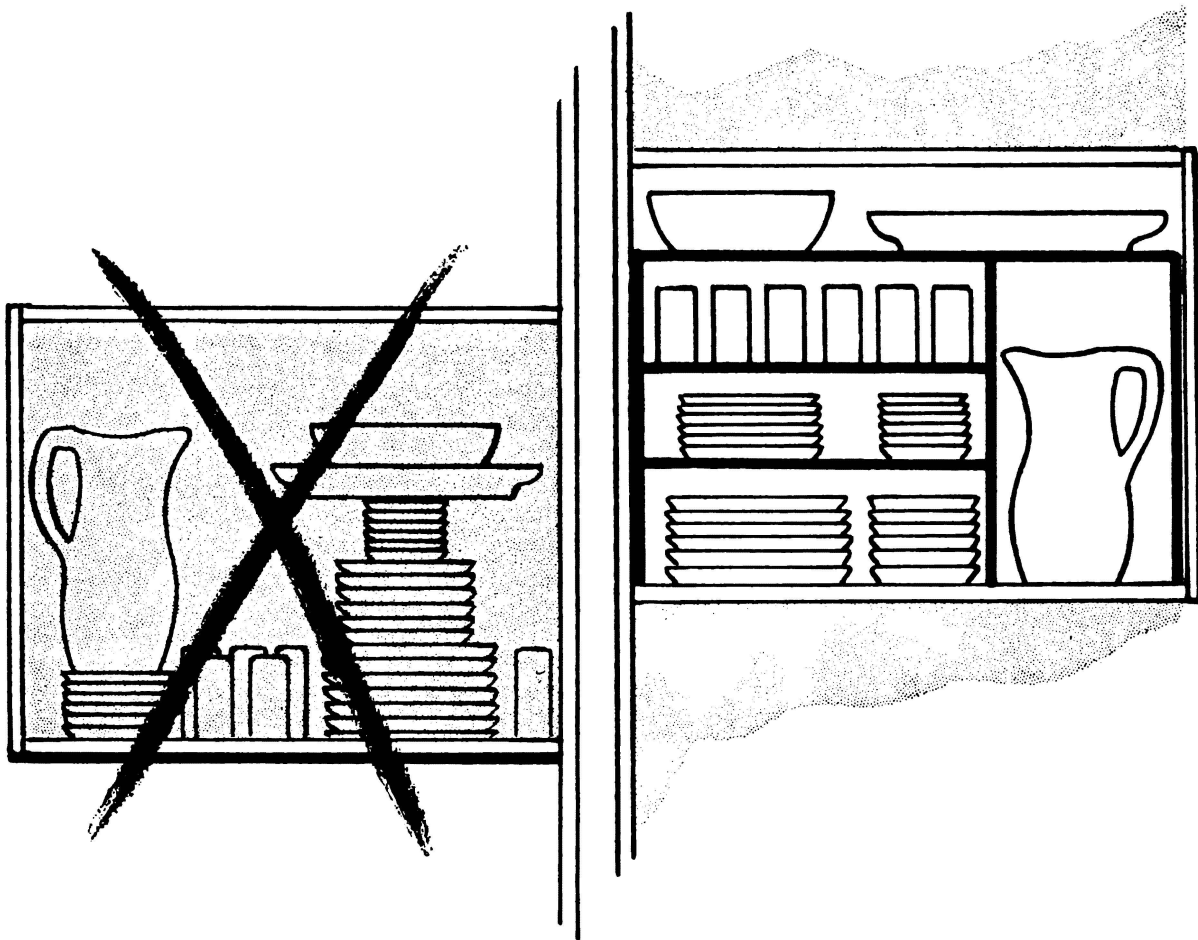

In your kitchen reduce the "chorage" by improving facilities for storage

Circular 965

September 1964

Agricultural Extension Service
Virginia Polytechnic Institute
Blacksburg, Virginia

LD
5655
A761
c48
no.965
VPI
Spec

5 Keys to Good Storage

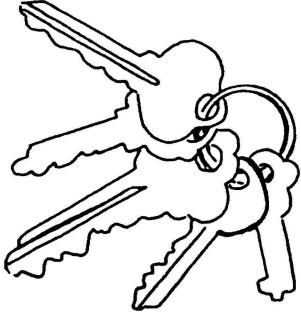

THESE FIVE KEYS CAN OPEN THE WAY TO BETTER USE OF THE STORAGE AREAS YOU NOW HAVE.

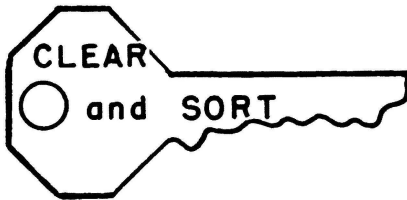

Weed out and sort items. Discard, or store in some other place, the seldom-used and duplicate items. There is a tendency to accumulate articles and regular sorting will help release space for the most important supplies.



Store most-used items within easy reach. Make use of storage space between eye and hip level first as this is the easiest to reach. Store heavy and awkward things at waist level or below.



Stack like articles only. For example, plates the same size may be stacked. Do not put small plates on larger ones or bowls on top of pie pans or you'll have to shuffle the whole stack to get the one on the bottom. Place only like articles one behind the other.



Store at point of first use. Utensils and foods used together should be stored together rather than rattling around in several cabinets. It is logical to store the coffee maker near the sink where it is first filled with water. But the coffee, a measuring spoon and measuring cup should be stored in this area also.

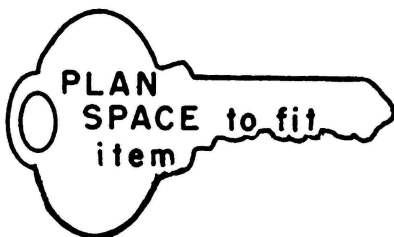

Plan for duplicates of items which are frequently used in two places. For example, store flour near the range and also at your mixing center. Keep some seasonings near the range and duplicates with your foods used in baking.

Plan space to fit the item. Store supplies so that they are easy to grasp. Small food packages should be on narrow shelves, one row deep, not one behind the other. Small items such as measuring spoons may be hung, knives should be stored to protect their cutting edge—and your fingers.

Group Supplies into Work Areas

TO HELP YOU in storing utensils and supplies conveniently think of your kitchen as three *work centers*. Although the work in these centers overlaps, the following check lists will help you place items where you use them most often.

Mixing

The Mixing Center includes the refrigerator, cabinet storage, and work counters.

Utensils stored here: bowls, mixer, egg beater, knives and spatulas, measuring cups and spoons, casseroles, baking pans, flour sifter, rolling pin.

Supplies stored here: flour, baking powder, cooking fats, seasonings, sugar, chocolate, cornstarch, prepared mixes, nut meats, gelatin.

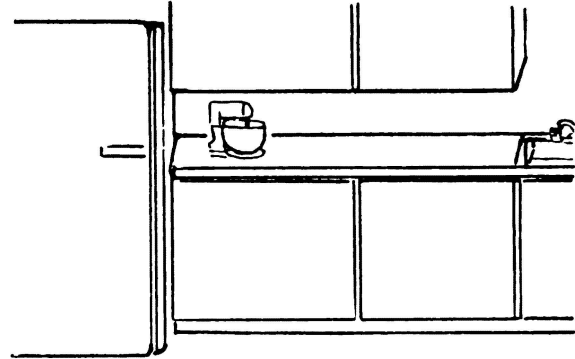

Cooking and Serving

The Cooking and Serving Center—centered around the range—includes storage areas and counters.

Utensils stored here: bread box, serving dishes, platters, cooking forks, fry pans, knives, spatulas, measuring cup and spoons, pot lids, teakettle, tea pot, cooling racks, griddle, meat slicing board, pressure cooker, roaster, tongs.

Supplies stored here: breakfast cereals (uncooked), flour, seasonings, pot holders, vegetable fat.

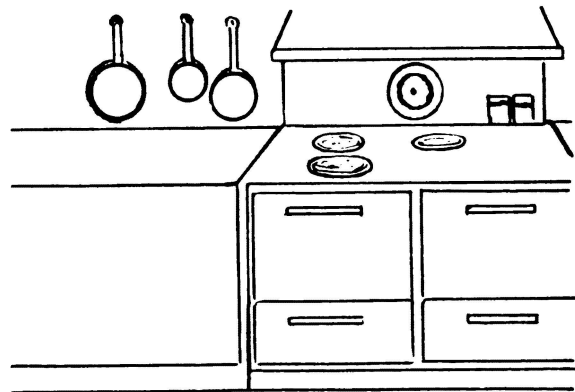

Cleanup

The Cleanup Center includes the sink, counters, and cabinets.

Utensils stored here: coffee maker, cutting board for vegetables, towel racks, dish pan, garbage container, knives, sauce pans, shears, sink strainer, waste basket, can opener, colander.

Supplies stored here: brushes, cleansers, dish towels, paper towels, scouring pads, soap or detergent, everyday dishes.

Note: Duplicates of items are indicated in some work centers for convenience.

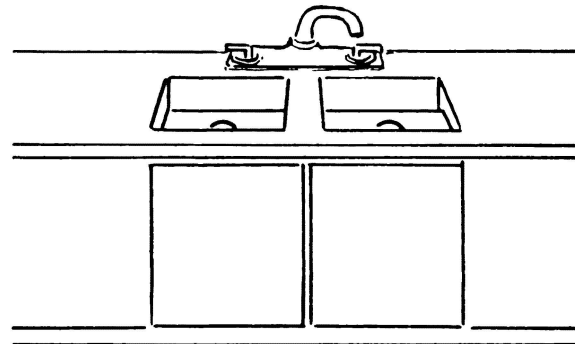

Shelves Too Far Apart

IT IS SAFE TO SAY that the majority of kitchen cabinets have shelves so far apart that several inches of space are wasted. You can correct this easily and inexpensively even if you live in a rented house or apartment.

Step shelves are built on legs and are not attached to the cabinet. They are usually narrow, about half the width of the cabinet or planned according to the size of articles to be stored. If the shelf is made shorter than the length of the cabinet, space can be allowed for storage of a tall pitcher or other tall item in the same area with dishes and glassware.

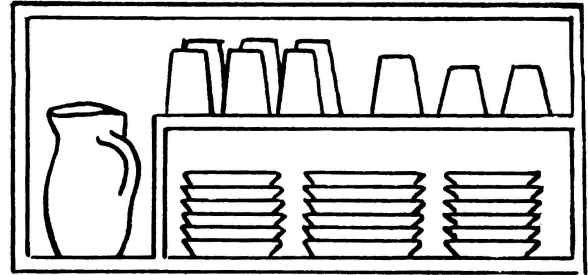
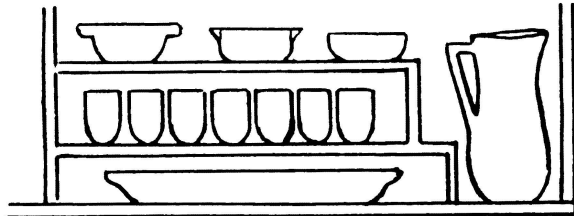

One step shelf may be placed on another in some cabinets where height permits. The top shelf is usually narrower so that articles below are easily removed.

ADD PERMANENT SHELVES

Shelves (usually half the width of existing shelves) may be added by one of the following methods.

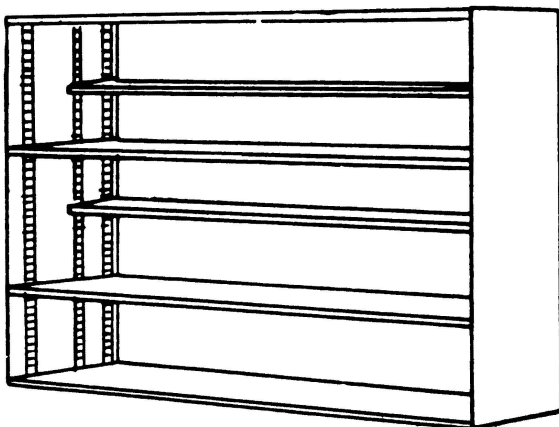

Metal stripping is used when dividing large storage areas. It is sturdy, dependable and more expensive than other methods. Stripping makes adjustment of shelves possible.

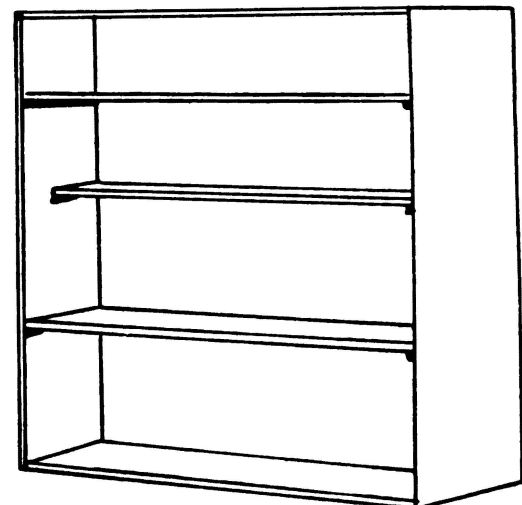

Cleats of wood attached to sides of storage area will support shelves. Shelf positions may be changed by adding cleats. This method requires strong side supports for storage area.

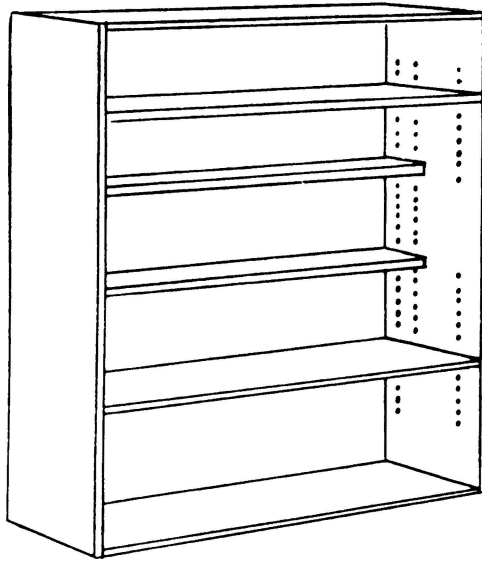

Metal brackets or sections of doweling may be inserted into parallel holes drilled into sides of storage area. A series of holes drilled one to two inches apart

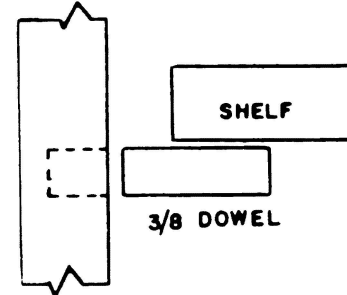
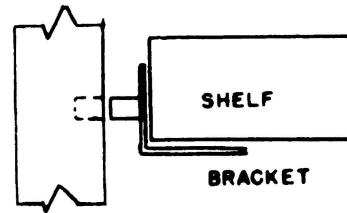

make it possible to change position of shelves. This is an inexpensive means of providing adjustable shelves.

ADD ACCESSORIES YOU CAN BUY

These portable storage conveniences are available in hardware or department stores and mail order houses.

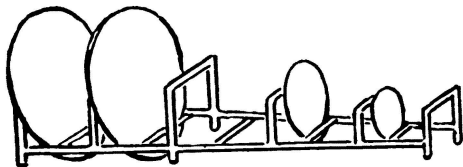
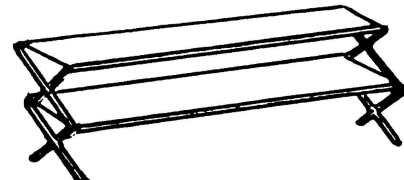
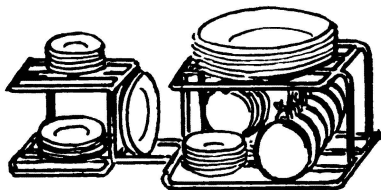

Plate rack. Available in different sizes and colors, these racks hold plates, bowls, pans, or lids in vertical position on the shelf.



Step shelf. Metal step shelves can be inserted in cabinet, used for dishes or foods.



Rack stores dishes of various types. Can be lifted out to carry dishes to table.

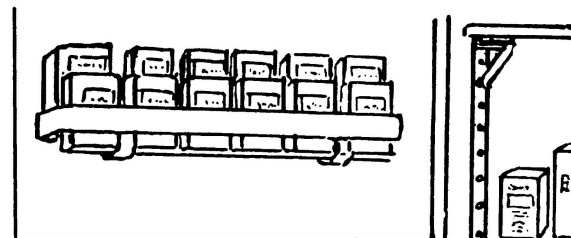

Spice rack. Fasten to door of cabinet in high enough position to clear other items stored on shelf inside. Some racks hold a double row of spices.

Shelves Too High or Too Low

IN HARD-TO-REACH SPOTS, store seldom used items, if possible. The alternate possibility is to equip these storage areas with devices which make utensils and supplies easy to grasp.

ADD VERTICAL DIVIDERS

Flat or odd-shaped equipment can be stored file-fashion to avoid stacking.

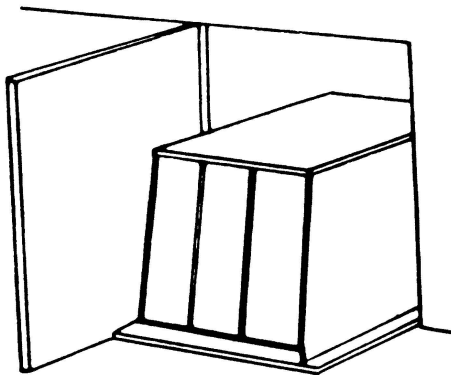

Portable dividers are made by building a box-like section to fit between permanent shelves. This structure can be easily moved for use elsewhere. In addition, portable dividers need not be the height of the permanent shelves, allowing room for a flat article to rest on top.

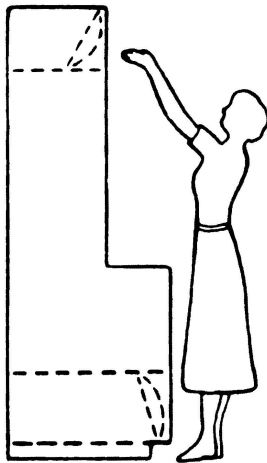

Slanting dividers. Articles are easily grasped from high shelves if dividers slant backward at bottom. When used for low shelves, dividers should slant backward at the top. This will allow the article stored to extend beyond the divider at the point where you grasp it. To prevent rolling of round articles, attach a narrow strip of wood across the front to serve as a guard. Removable dividers are an aid to cleaning.

To support dividers. When dividers are attached to fixed shelves, cleats of plywood, wood stripping, quarter round or eyelet screws are used to hold dividers in place.

Grooving is often used to support dividers in new construction. Some methods of supporting shelves are shown below.

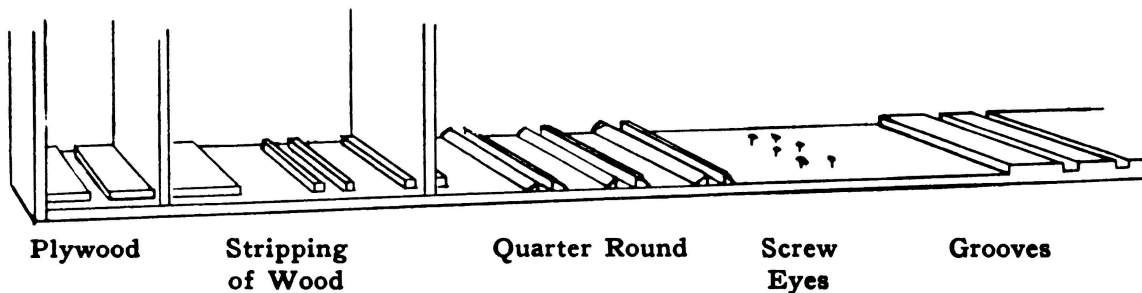

To Use Space Under the Sink

SPACE UNDER THE SINK is often wasted because of the location of water pipes. Here are some suggestions for ways to make this area more useful.

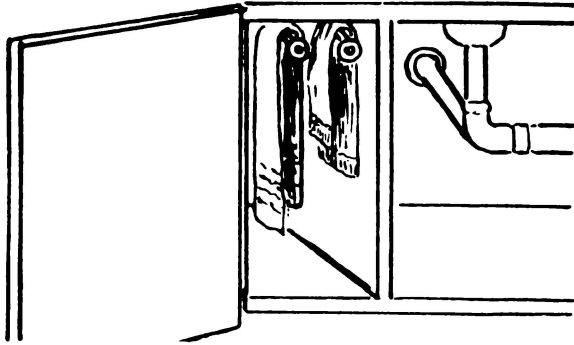

Towel bars. Extension towel bars may be attached to the side of the cabinet, or a stationary rod may be fastened to the inside of the door.

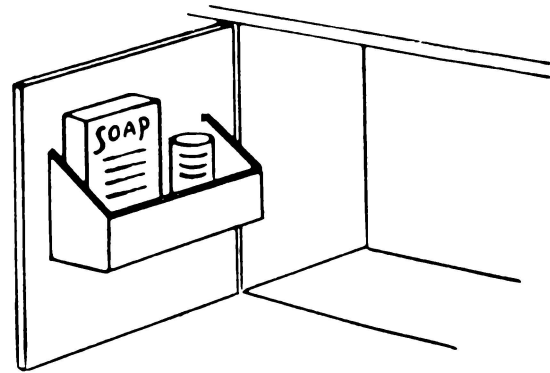

Rack for cleansers. A rack may be made from wood and attached to the inside of the door. Plastic and metal racks of this type can also be purchased. Some have a rod for hanging a dishcloth also.

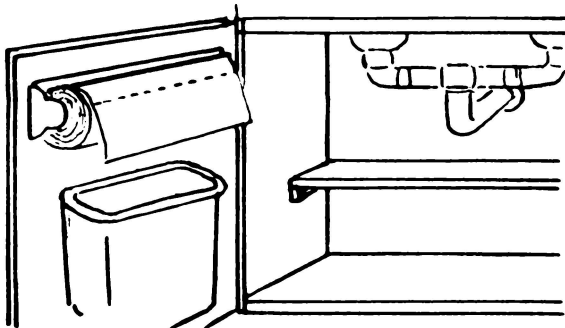

Waste can or basket. This can be attached to door. Make certain it will clear the sides of the opening when door swings shut.

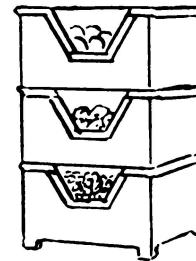

Vegetable bins. Stackable plastic bins for potatoes and onions are now available, or you can make wooden bins but be sure to allow for ventilation.

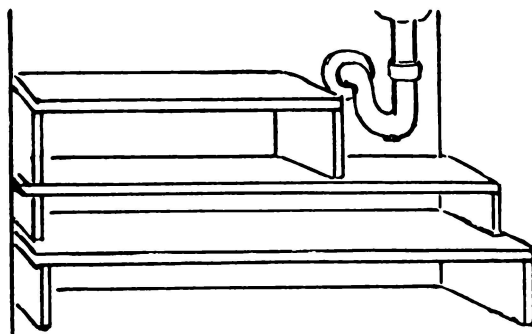

Step shelves. One or more wooden step shelves may be fitted around the pipes to give storage for cleansers, empty bottles, tool kit, etc.

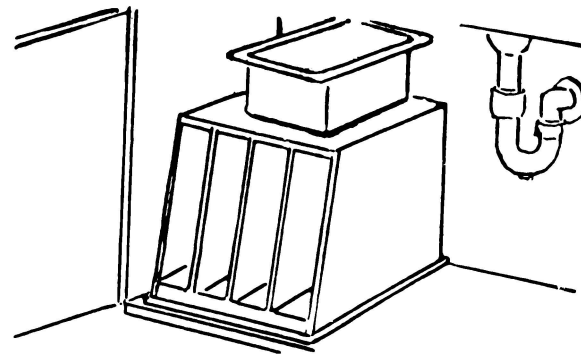

Vertical dividers. Portable vertical dividers can be used here also for drain racks, wash basins, and flat items.

To Use All Space in Deep Cabinets

YOU NEED SOME DEEP STORAGE but often base cabinets 24 inches deep provide more depth than you need in proportion to the size of items stored.

On deep shelves keep large items such as large kettles, Dutch oven, long handled pans (with handle extending outward) because these will probably not allow room for others to get lost behind them.

To use the rest of the deep space, consider these devices.

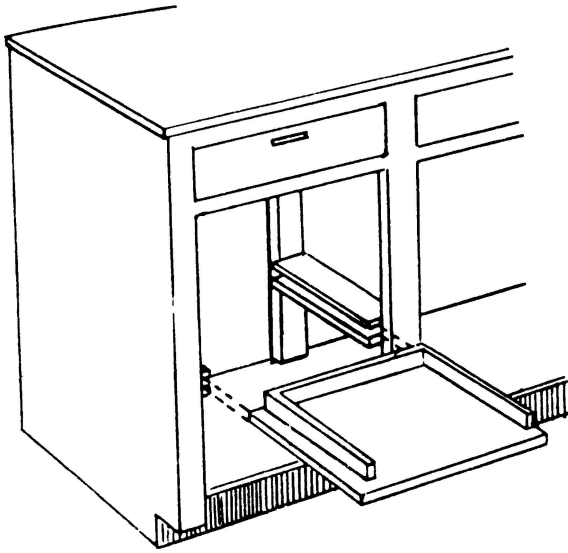

Sliding Shelves

Particularly good in the lower areas, the sliding shelf brings all items out where you can see them and conveniently remove them. A guard may be used to keep articles from sliding off the back and sides of the tray. Two or more sliding shelves may be used in a base cabinet.

Linen Trays

Deep cabinets may be equipped with several sliding sheets of plywood supported by metal stripping or cleats. Storage of linens in this manner is convenient.

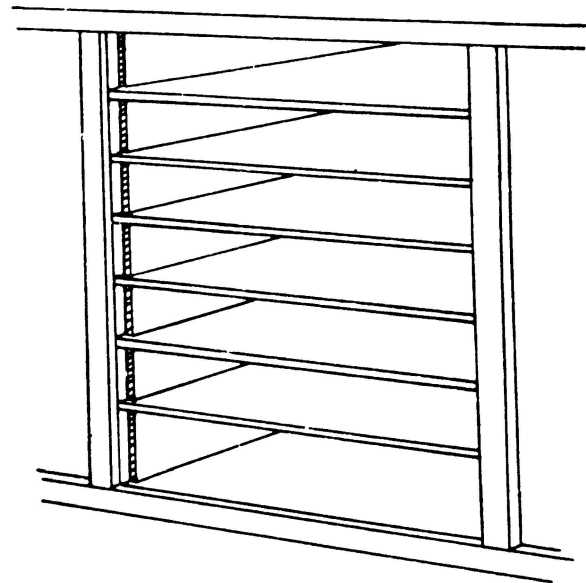
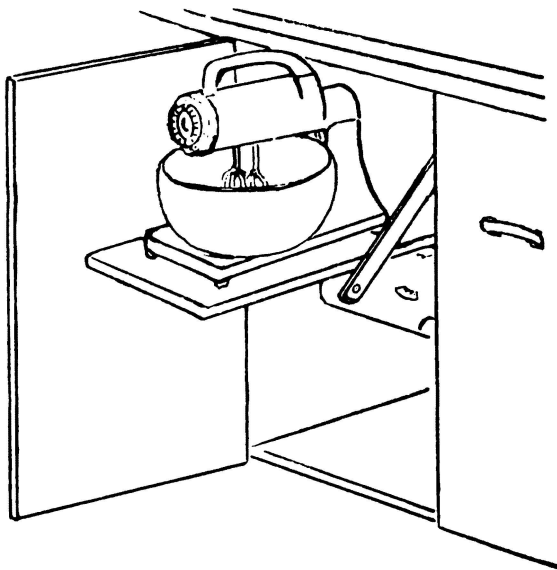

Shelf for Electric Mixer

Electric mixer may be stored on a shelf which pulls out and upward when ready for use. Hardware for this type of shelf is available through many lumber companies. The center shelf of an existing cabinet would need to be removed before making this installation.

Tray Storage

Sections of base cabinets may be used for tray and platter storage by adding vertical dividers. If high enough some flat electric appliances such as fry pan may be stored here also with the handle pointed toward the door. For extra large trays, the center shelf of the cabinet would need to be removed before installing dividers. (See page 6 for method of supporting dividers.)

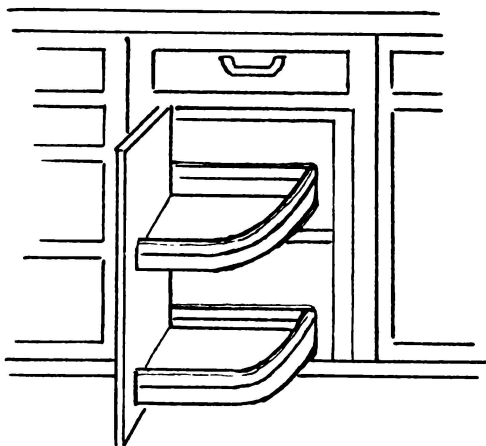
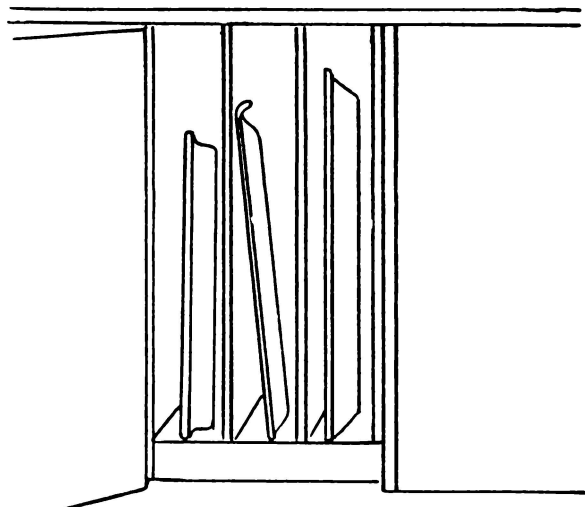

Swing-out Shelves

Shelves can be added to the doors. Be certain they are well supported and have guards to prevent supplies from falling off. Center shelf will not need to be removed if door shelves are carefully spaced.

Sliding Pothooks

Center shelf of deep cabinet may be removed and extension rod with pothooks attached to top part of cabinet. This device is now available in many stores for do-it-yourself installation.

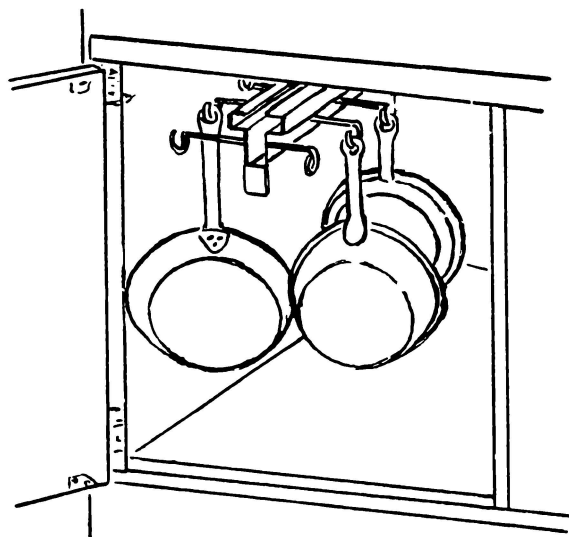

To Keep Drawers Orderly

DRAWERS EASILY BECOME JUMBLED unless dividers are made suitable for the small articles stored.

To make a pattern for drawer dividers, fit a piece of paper in the bottom of the drawer, arrange items on the paper. Mark space needed for each item or group allowing $\frac{1}{4}$ inch for the thickness of the divider. Remove paper and draw dividing lines.

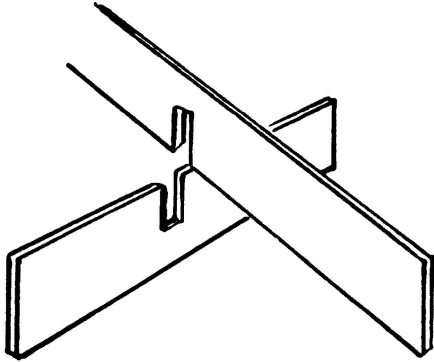

Dividers

Heavy corrugated cardboard dividers may be used for a few weeks to try out your plan before making permanent dividers. Cut slits (about $\frac{1}{4}$ inch wide) half of the height of the divider. Fit dividers together by matching slits as shown in picture. Allow one inch or more space above the divider for clearance when closing the drawer.

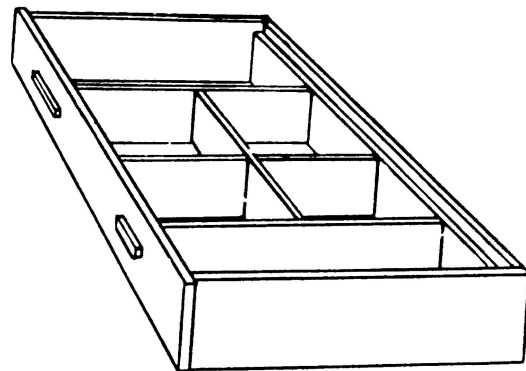

Wide Drawers

Large drawers may need a number of partitions patterned to fit the articles stored. Plan to keep little used equipment in the rear sections.

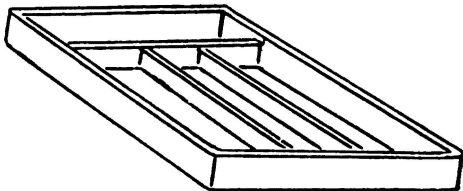

Cutlery Tray

Removable trays of plastic or wood can be bought for storage of cutlery and silver. Place tray in drawer so that handles of articles stored are toward the front for easy grasping. Any remaining space left in the drawer may be used for larger items.

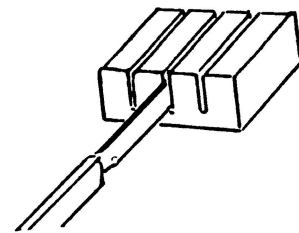

Knife Slats

A wooden block with slots for knives may be glued or nailed to the bottom of a drawer. Allow $4\frac{1}{2}$ to 5 inches for storage of three knives, depending on the thickness of handles. Proper knife storage helps keep cutting edges sharp and also protects fingers.

To Divide a Deep Drawer

DEEP DRAWERS have a number of uses if they are located in the right work areas. Some are equipped with metal liners for storing bread. Some large bowls or pressure cookers may be stored in deep drawers without wasting space.

Sliding Tray

Make a deep drawer more usable for small items or linens by fitting it with a sliding tray. This helps avoid stacking unlike items. The tray may slide from side to side or front to back but should not cover more than half the top of the drawer.

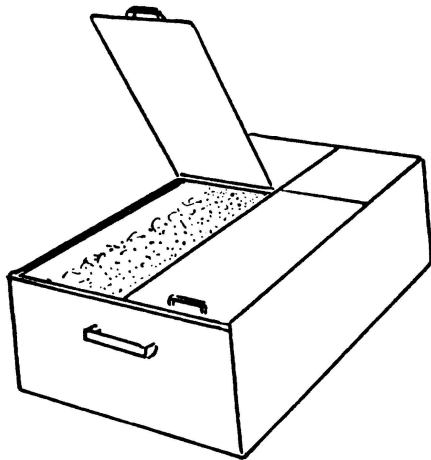

Canister Dividers

Fit in sheet metal containers with hinged lift-up covers to serve as canisters for flour and sugar. If drawer is large you may use three compartments and store brown sugar, graham flour, or some food which is less often used in the back. Make certain drawer will slide freely with the weight of the contents.

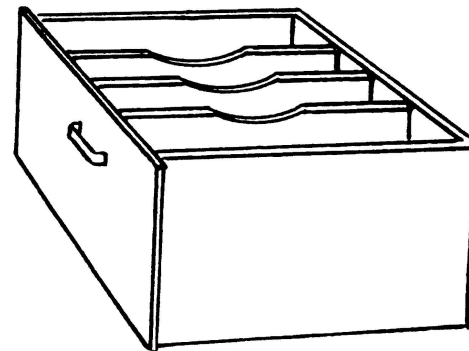
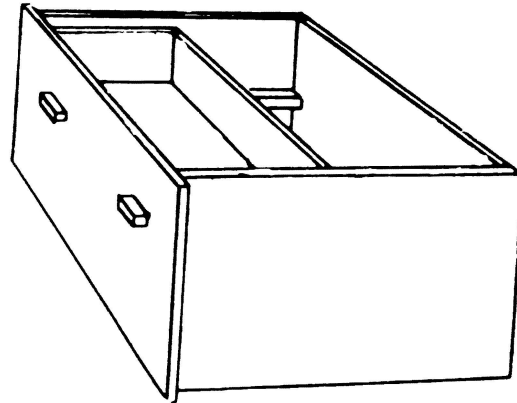

Vertical Dividers

Deep drawers may be made into pan files by adding removable dividers. Store pie, cake, and bread pans, muffin tins, cake cooling racks, platters, trays, and other flat items.

The partitions may run parallel or perpendicular to the drawer front depending on the width of the drawer and size of equipment to be stored.

MORE TIPS FOR DRAWER USE

- Wax the glides of wooden drawers so that they will pull out easily.
- If several kinds of placemats are to be stored in the same drawer, place each kind on a sheet of cardboard cut to fit. Then the entire set can be lifted out without wrinkling to get to the one below.
- The back of a drawer should be $\frac{3}{4}$ inch higher than the sides to prevent it from pulling all the way out when in use.

How to Use Pegboard

PEGBOARD may be used in a variety of ways for hanging utensils or shelves. Allow about $\frac{1}{4}$ inch of free space behind it for the inserted "pegs." Wood strips attached to the back of the pegboard will be satisfactory. Another way is to hang the pegboard with picture hooks and picture wire. Many different types of hardware or pegs are available for supporting a variety of tools and utensils.

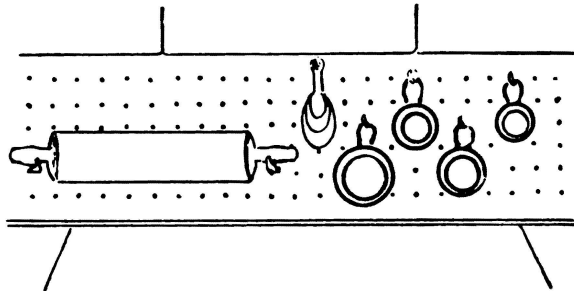
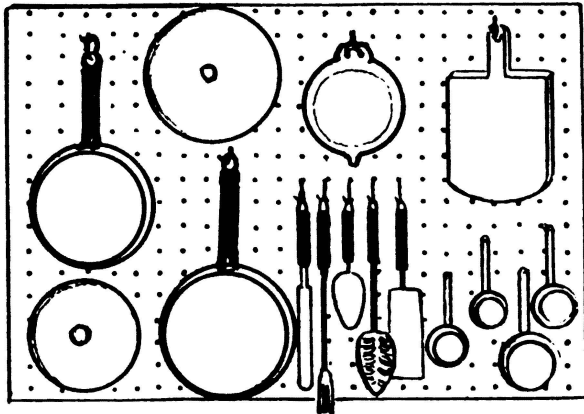

Near Mixing Center

Mount pegboard on wall between wall and base cabinets and use hooks to hold rolling pin, measuring cups, measuring spoons.

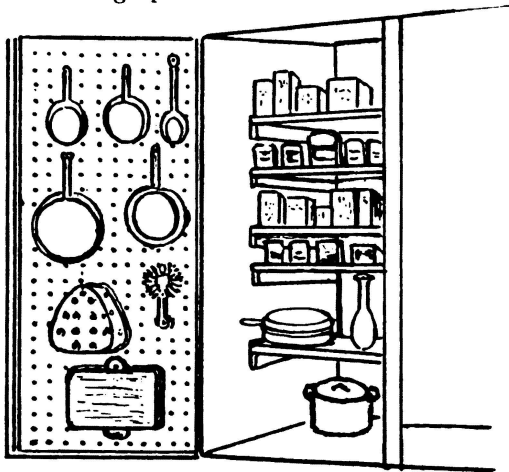

Above Counter Space

If you have unused wall area over the range or elsewhere in the room, cut a piece of pegboard large enough to hold the utensils you wish to hang here. Board may be painted any color to go with decor of the room.

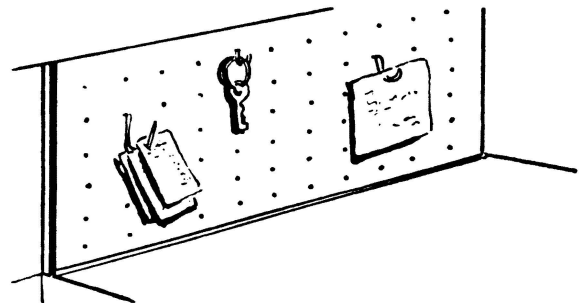

Over Desk

Hang pegboard over a desk for use as a bulletin board.

On Closet Door

Line the inside of a closet, pantry or cabinet door. Insert the proper hardware for shelf supports and hanging utensils.

A large section of pegboard behind a door is handy for hanging jackets, repair tools, etc.

How to Hang Equipment

ARTICLES WHICH ARE USED OFTEN may be hung in the open without collecting dust.

Towel Bars

Plastic, glass, metal and wooden rods may be used to hang towels and other cloths. Towel rings of plastic, glass and metal are also available. Some of these may be attached with adhesive, others with screws or nails.

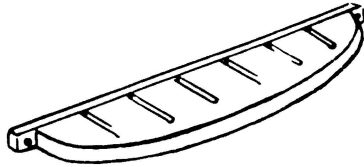
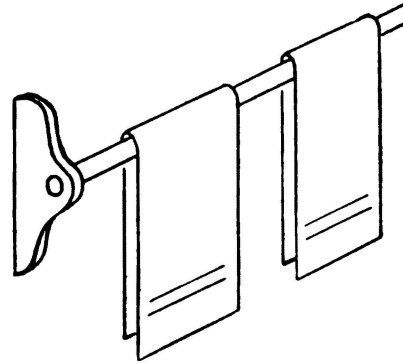

Knife Racks

Wooden knife racks may be made or bought and hung on the wall above the work counter. A device which holds several knives by magnetic attraction is also available for wall mounting.

Hooks for Small Articles

Small hooks of this type may be used to hang measuring cups, a dust pan or other light weight equipment. Some hooks made of plastic have adhesive backing for easy attachment to tile, metal, wood or plaster.



Large Articles

Large hooks such as these may be fastened to a door, wall or side of cabinet. Similar hooks are also available for use in pegboard.

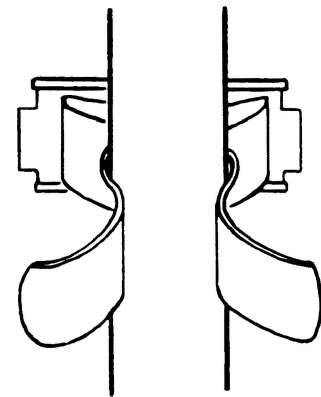
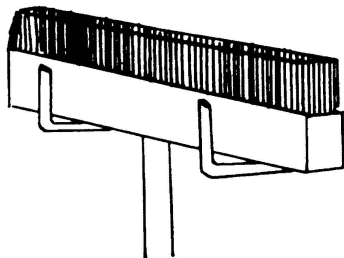

Broom and Mop Clamps

Clamps similar to this picture screw into the wall, door or side of a broom cabinet. Any handle tools, brushes, mops, brooms may be hung.

Cabinet Doors for Convenient Storage

YOU CAN INCREASE your finger tip storage by making use of the interior of cabinet door.

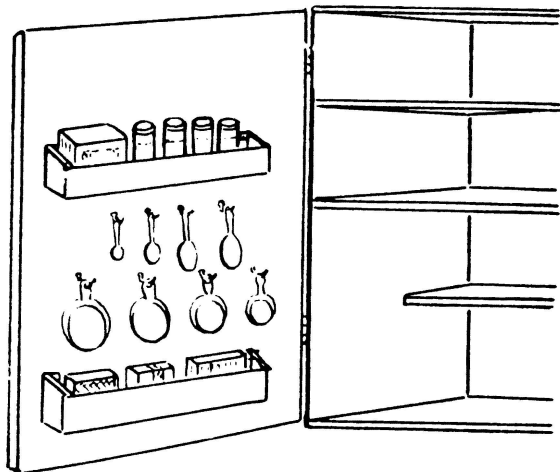

Door Shelves

Door shelves or racks can be used for small food packages. Do not store heavy articles such as canned goods here as the door hinges may not be strong enough to prevent sagging. Place the rack high enough on the door to clear packages on shelf inside.

These shelves may be made or bought at a hardware store.

Hang measuring cups and spoons on the wall cabinet door.

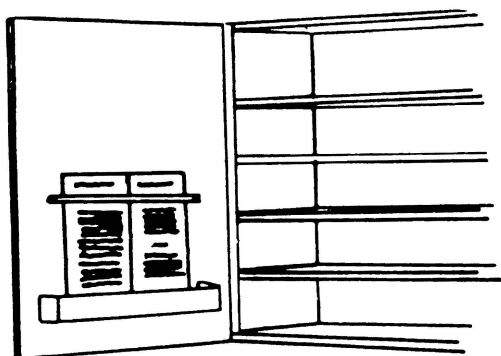

Cookbook Rack

A rack for a cookbook consists of a shelf 1 to 2 inches wide on which the book rests. A strip of elastic near the top of the book holds it in place whether open or closed. When the wall cabinet door is open the open book is at eye level for quick reference.

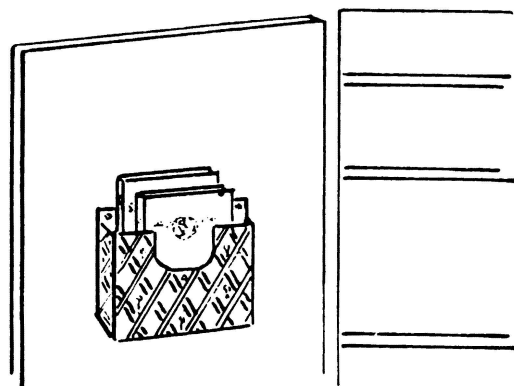

Appliance Instruction Booklets

A flat box may be partially cut away and hung on the inside of a cabinet door. To make it more attractive, cover with shelf paper or wallpaper. Store instruction booklets for appliances you use in the kitchen.

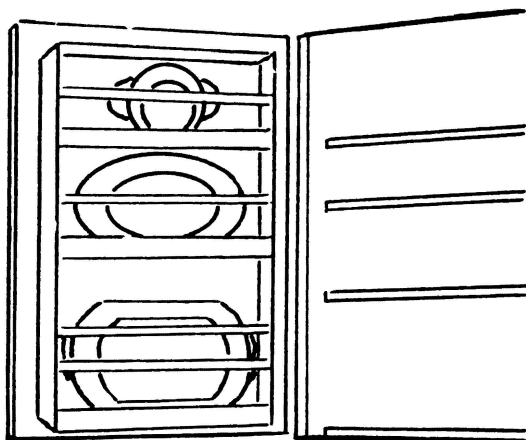

Platters

Racks on the inside of a dish cabinet may hold platters, which are too large for a shelf. A practical depth for the rack is about 3 inches. A narrow wood or metal guard at the bottom and one or two elastic strips above will hold the platter in place. For the largest platters shelves of the cabinet may need to be cut back about three inches if they come all the way to the front.

Take a Close Look at Your Kitchen

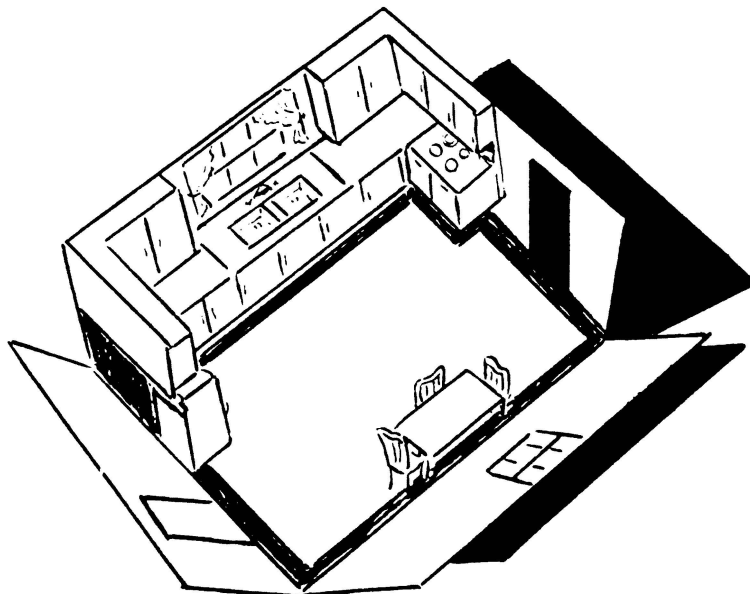

DOES IT HAVE ANY OF THESE FAULTS?

See pages

- Are you wasting space because shelves are too far apart? 4- 5
- Do you have trouble reaching high shelves or stooping to low ones?..... 6
- Is there wasted space under the sink? 7
- Are cabinets too deep causing some supplies to get lost behind others? 8- 9
- Are cabinet drawers cluttered? 10-12
- Is there unused wall space? 12
- Could you increase the storage space by hanging some equipment? 13
- Could you store some supplies on cabinet doors? 14

Reprint courtesy University of Idaho, Oregon State University, and Washington State University. Material prepared by Bernice Strawn, Home Management Specialist, Oregon State University, in cooperation with home management specialists at Idaho and Washington.



Issued in furtherance of cooperative extension work in agriculture and home economics, Acts of May 8 and June 30, 1914, in cooperation with the U. S. Department of Agriculture. W. H. Daughtrey, director, Agricultural Extension Service, Virginia Polytechnic Institute, Blacksburg, Virginia.

IP--9:64--5M--2--5--HM