

Solutions to Problems in *Electromagnetics*, Vol. 1
Version 1.1

Steven W. Ellingson
ellingson.1@vt.edu
Virginia Tech

August 10, 2018

This manual accompanies *Electromagnetics Vol. 1*, an open textbook freely available at <https://doi.org/10.21061/electromagnetics-vol-1>

© 2018 Steven W. Ellingson CC BY SA 4.0.

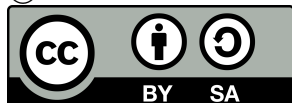

<https://creativecommons.org/licenses/by-sa/4.0/>

Contents

2	Electric and Magnetic Fields	3
3	Transmission Lines	6
5	Electrostatics	34
6	Steady Current and Conductivity	69
7	Magnetostatics	76
8	Time-Varying Fields	91
9	Plane Wave Propagation in Lossless Media	103

Chapter 2

Electric and Magnetic Fields

[m0002] [1]

2.2-1

From the problem statement, $V = 1.5 \text{ V}$ and $d = 30 \text{ }\mu\text{m}$, so

$$|\mathbf{E}| \approx \frac{V}{d} = \boxed{50 \text{ kV/m}}$$

[m0011] [1]

2.4-1

From the problem statement, $V = 12 \text{ V}$, $\epsilon_r = 6$, and $d = 90 \text{ }\mu\text{m}$, so the electric field intensity is

$$|\mathbf{E}| \approx \frac{V}{d} \cong 133 \text{ kV/m}$$

Subsequently, the electric flux density is

$$|\mathbf{D}| = \epsilon_r \epsilon_0 |\mathbf{E}| = \boxed{7.08 \text{ }\mu\text{C/m}^2}$$

Chapter 3

Transmission Lines

3.6-1

(a) The expression for the voltage $\tilde{V}(z)$ traveling in the $+z$ direction contains the factor $e^{-\gamma z}$. The propagation constant $\gamma = \alpha + j\beta$, where α and β are real-valued constants. Therefore, the ratio of the voltage at a distance l from some other point on the transmission line is:

$$\frac{\tilde{V}(z+l)}{\tilde{V}(z)} = \frac{e^{-\gamma(z+l)}}{e^{-\gamma z}} = e^{-\gamma l} = e^{-\alpha l} e^{-j\beta l}$$

The magnitude of this difference is just the first factor; i.e., $e^{-\alpha l}$. We also know that

$$\gamma = \sqrt{(R' + j\omega L')(G' + j\omega C')}$$

At 100 MHz, we find $\gamma = 0.00850 + j3.14468 \text{ m}^{-1}$. Therefore, $\alpha = 0.00850 \text{ m}^{-1}$, and the voltage after 1 m is

$$(1 \text{ V}) \exp[-(0.00850 \text{ m}^{-1})(1 \text{ m})] = \boxed{0.9915 \text{ V}}$$

(b) From part (a) we know the phase of this difference is just the phase of the factor $e^{-j\beta l}$. Since $\beta = 3.14468 \text{ rad/m}$, the phase of $e^{-j\beta l}$ is $\boxed{179.8^\circ}$ for $l = 1 \text{ m}$.

(c) For a radio wave in free space, there should be essentially $\boxed{\text{no attenuation}}$ over 1 m, as long as this 1 m span is located far from the transmitter. This is because free space propagation contains no loss mechanisms analogous to R' or G' in the transmission line model. At $f = 100 \text{ MHz}$, the wavelength of the radio wave is $\lambda = c/f \cong 3 \text{ m}$. That means the phase rotates by 360° in 3 m, which is $\boxed{120^\circ}$ in 1 m. Note that the wavelength of the radio wave is significantly longer than the wavelength of the signal in the transmission line.

[m0027] [2]

3.6-2

The question is whether

$$\tilde{V}(z) = V_0^+ e^{-\gamma z} + V_0^- e^{+\gamma z}$$

is a solution to the TEM transmission line wave equation

$$\frac{\partial^2}{\partial z^2} \tilde{V}(z) - \gamma^2 \tilde{V}(z) = 0$$

where V_0^+ , V_0^- , and γ are complex-valued constants. To determine this, we substitute the candidate solution into the equation and determine if equality holds. Taking the first derivative of the candidate solution:

$$\frac{\partial}{\partial z} \tilde{V}(z) = -\gamma V_0^+ e^{-\gamma z} + \gamma V_0^- e^{+\gamma z}$$

Repeating to get the second derivative:

$$\frac{\partial^2}{\partial z^2} \tilde{V}(z) = +\gamma^2 V_0^+ e^{-\gamma z} + \gamma^2 V_0^- e^{+\gamma z}$$

Now making the substitutions into the left side of the wave equation:

$$\begin{aligned} & [+ \gamma^2 V_0^+ e^{-\gamma z} + \gamma^2 V_0^- e^{+\gamma z}] - \gamma^2 [V_0^+ e^{-\gamma z} + V_0^- e^{+\gamma z}] \\ &= +\gamma^2 V_0^+ e^{-\gamma z} + \gamma^2 V_0^- e^{+\gamma z} - \gamma^2 V_0^+ e^{-\gamma z} - \gamma^2 V_0^- e^{+\gamma z} \\ &= 0 \end{aligned}$$

which is the the right hand side of the wave equation, as expected.

[m0052] [1]

3.7-1

It is true that the real part of the characteristic impedance must be positive.

Here's a mathematical argument: Recall:

$$Z_0 = \sqrt{\frac{R' + j\omega L'}{G' + j\omega C'}}$$

Also note that R' , L' , G' and C' must all be positive or zero. Therefore, the numerator and denominator of the above expression, before taking the square root, must both have phase in the range 0 to $+\pi/2$. This means the numerator divided by the denominator, again before taking the square root, must have phase in the range $-\pi/2$ to $+\pi/2$. Taking the principal square root reduces the phase by a factor of two, the phase of Z_0 must be in the range $-\pi/4$ to $+\pi/4$. Subsequently, the real part of Z_0 must be positive.

Here's a physical argument: A positive-valued real-valued component of an impedance represents the dissipation of power (e.g., resistance) or transfer of power out of a system (e.g., to a load). Conversely, a negative-valued real-valued component of an impedance represents the creation of power or the introduction of power into a system; in other words, an active device. Since the concept of characteristic impedance applies to transmission lines, and since transmission lines are passive devices, the real component of the characteristic impedance must be positive.

[m0080] [1]

3.8-1

The physical current:

$$\begin{aligned}i(z, t) &= (2 \text{ A}) \sin((3 \text{ rad/s})t + (4 \text{ rad/m})z + 5 \text{ rad}) \\ &= (2 \text{ A}) \cos((3 \text{ rad/s})t + (4 \text{ rad/m})z + 5 \text{ rad} - \pi/2)\end{aligned}$$

so

$$\tilde{I}(z) = \left[(2 \text{ A}) e^{j((5-\pi/2) \text{ rad})} \right] e^{j(4 \text{ rad/m})z}$$

[m0080] [2]

3.8-2

Converting to time-domain representation:

$$v(x, t) = \operatorname{Re} \left\{ \tilde{V}(x) e^{j\omega t} \right\} = \operatorname{Re} \left\{ V_0 e^{+j\beta x} e^{j\omega t} \right\}$$

The problem's statement implies V_0 is complex-valued. To accommodate this, we define the magnitude and phase of V_0 as follows:

$$V_0 \triangleq |V_0| e^{j\pi/3}$$

Then:

$$v(x, t) = \operatorname{Re} \left\{ |V_0| e^{j\pi/3} e^{+j\beta x} e^{j\omega t} \right\} = |V_0| \operatorname{Re} \left\{ e^{j(\omega t + \beta x + \pi/3)} \right\}$$

Finally, using the identity $e^{j\theta} = \cos \theta + j \sin \theta$, we obtain

$$v(x, t) = \boxed{|V_0| \cos(\omega t + \beta x + \pi/3)}$$

This wave is traveling in the $-x$ direction.

[m0080] [3]

3.8-3

The form given in the problem statement is a phasor, describing a wave traveling in the $+\phi$ direction. To obtain the time domain form:

$$v(\phi, t) = \text{Re} \{ V_0 e^{-j\beta\phi} e^{j\omega t} \} = |V_0| \cos(\omega t - \beta\phi + \psi)$$

where ψ , the phase of V_0 , is not given. Note

$$\beta = \frac{2\pi}{\lambda} \cong 62.832 \text{ rad/m}$$

Furthermore, we are told that $v(\phi = \lambda/4, t = 0)$ is a maximum, so:

$$|V_0| \cos\left(-\beta\frac{\lambda}{4} + \psi\right) = |V_0| \cos\left(-\frac{\pi}{2} + \psi\right)$$

is a maximum, which means $\psi = +\pi/2$. Therefore:

$$v(\phi, t) = \boxed{|V_0| \cos\left(\omega t - [62.832 \text{ rad/m}] \phi + \frac{\pi}{2}\right)}$$

The problem statement does not provide sufficient information to determine $|V_0|$ or ω .

[m0083] [1]

3.9-1

From the problem statement, $Z_0 = 72 \Omega$, $L' = 0.5 \mu\text{H}/\text{m}$, $f = 80 \text{ MHz}$, and the low-loss approximations apply. Using the low-loss approximation $Z_0 \approx \sqrt{L'/C'}$:

$$C' \approx \frac{L'}{Z_0^2} \cong 96.4 \text{ pF}/\text{m}$$

Subsequently, the phase velocity is

$$v_p \approx \frac{1}{\sqrt{L'C'}} \cong \boxed{1.44 \times 10^8 \text{ m/s}}$$

and the phase propagation constant is

$$\beta \approx \omega\sqrt{L'C'} = 2\pi f\sqrt{L'C'} \cong \boxed{3.49 \text{ rad/m}}$$

[m0143] [1]

3.10-1

The characteristic impedance Z_0 of coaxial cable, assuming the low-loss assumptions apply, is

$$Z_0 \approx \frac{60 \Omega}{\sqrt{\epsilon_r}} \ln \frac{b}{a}$$

where ϵ_r is the relative permittivity of the spacer material, and a and b are the radii of the inner and outer conductors, respectively. Air has $\epsilon_r \approx 1$ and is lossless to a very good approximation. We are also told the resistance of the inner and outer conductors is negligible. Therefore, the low-loss assumptions apply, and we are justified in using the above expression.

One way to reduce Z_0 from 90Ω to 62Ω is to replace the air spacer with a material spacer having

$$\epsilon_r = \left(\frac{90 \Omega}{62 \Omega} \right)^2 \cong 2.11$$

Thus, one solution is to replace air with a low-loss material having $\epsilon_r \cong 2.11$. Another way is to reduce b/a . For the 90Ω cable, we determine that

$$\frac{b}{a} \approx \exp \left(\frac{90 \Omega}{(60 \Omega) / \sqrt{1}} \right) \cong 4.48$$

To reduce Z_0 to 62Ω , we require

$$\frac{b}{a} \approx \exp \left(\frac{62 \Omega}{(60 \Omega) / \sqrt{1}} \right) \cong 2.81$$

Thus, a second solution is to keep air as the spacer material but reduce b/a to 2.81.

[m0084] [1]

3.12-1

The voltage reflection coefficient is

$$\Gamma = \frac{Z_L - Z_0}{Z_L + Z_0} = \frac{500 \, \Omega - 75 \, \Omega}{500 \, \Omega + 75 \, \Omega} \cong +0.739$$

Therefore, the peak voltage of the reflected wave at the antenna input is

$$(0.739) (30 \, \text{V}) \cong 22.2 \, \text{V}$$

The line is lossless, so there is no attenuation of the reflected wave along the return trip from antenna to transmitter. Therefore, the peak voltage of the reflected wave at the output of the transmitter is 22.2 V.

[m0084] [2]

3.12-2

From the problem statement, \tilde{V}_0^+ has magnitude 7 mV and phase 180° , so $\tilde{V}_0^+ = -7$ mV. Also from the problem statement $Z_0 = 60 \Omega$ and $Z_L = 20 \Omega$. Therefore,

$$\Gamma = \frac{Z_L - Z_0}{Z_L + Z_0} = -0.5$$

Subsequently, $\tilde{V}_0^- = \Gamma \tilde{V}_0^+ = +3.5$ mV. Thus, the magnitude of the reflected wave is 3.5 mV, and the phase is 0° .

[m0084] [3]

3.12-3

The voltage reflection coefficient is

$$\Gamma = \frac{Z_L - Z_0}{Z_L + Z_0} = \frac{33 \Omega - 140 \Omega}{33 \Omega + 140 \Omega} \cong -0.6185$$

Therefore, the magnitude of the reflected voltage wave is

$$|\Gamma (3 \text{ V})| \cong \boxed{1.86 \text{ V}}$$

and the phase of the reflected voltage wave is

$$170^\circ + 180^\circ \rightarrow \boxed{-10^\circ}$$

[m0086] [1]

3.13-1

- (a) On short-circuited line, $\Gamma = 1$. Therefore, the current at a voltage maximum is zero.
- (b) The voltage at a short circuit is zero. The distance between voltage extrema is $\lambda/4$, so $\lambda/4 = 8$ cm. The distance between voltage maxima is $\lambda/2 = 16$ cm. Therefore, the distance between the short circuit and the second voltage maximum is $8 + 16 = \underline{24}$ cm.

[m0081] [1]

3.14-1

First note

$$|\Gamma| = \frac{\text{SWR} - 1}{\text{SWR} + 1}$$

So in this case

$$|\Gamma| \leq \frac{1.2 - 1}{1.2 + 1} \cong 0.091$$

Also note:

$$\Gamma = \frac{Z_L - Z_0}{Z_L + Z_0}$$

where in this case $Z_0 = 50 \Omega$ and Z_L is the input impedance of the amplifier. Solving for Z_L we find:

$$Z_L = Z_0 \frac{1 + \Gamma}{1 - \Gamma}$$

Since the imaginary component of Z_0 is zero, and since the imaginary component of Z_L is negligible, Γ must be real-valued. Therefore, $-0.091 \leq \Gamma \leq +0.091$ and

$$\boxed{41.7 \Omega \leq Z_L \leq 60.0 \Omega}$$

.

[m0081] [2]

3.14-2

From the problem statement, $Z_0 = 72 \Omega$ and $Z_L = 60 \Omega$. Therefore, the voltage reflection coefficient is

$$\Gamma = \frac{Z_L - Z_0}{Z_L + Z_0} \cong \boxed{-0.091}$$

and the standing wave ratio is

$$\text{SWR} = \frac{1 + |\Gamma|}{1 - |\Gamma|} = \boxed{1.2}$$

[m0087] [1]

3.15-1

The input impedance of a lossless line is periodic in length, with period $\lambda/2$. Therefore, the line is exactly 3 periods long, which means the input impedance is equal to the load impedance $72 + j42 \Omega$.

[m0088] [1]

3.16-1

In this case, the input impedance is

$$Z_{stub} = -jZ_0 \cot \beta l$$

where $Z_0 = 75 \Omega$, $l = 13 \text{ cm}$, and

$$\beta = \frac{\omega}{v_p} = \frac{2\pi f}{0.55c}$$

where $f = 900 \text{ MHz}$. Therefore, $\beta \cong 34.3 \text{ rad/m}$, $\beta l \cong 4.45 \text{ rad}$, and $Z_{stub} \cong -j19.7 \Omega$.

[m0088] [2]

3.16-2

From the problem statement: $Z_0 = 75 \Omega$, $f = 1.5 \text{ GHz}$, $Z_{in} = +j300 \Omega$ is desired, and $v_p = 0.6c$. Note that for a short circuit, in this case:

$$Z_{in} = +jZ_0 \tan \beta l = +j300 \Omega$$

so

$$\beta l \cong 1.3258 \text{ rad}$$

Note

$$\beta = \frac{\omega}{v_p} = \frac{2\pi f}{0.6c} \cong 52.36 \text{ rad/m}$$

so $l \cong 2.53 \text{ cm}$

[m0145] [1]

3.17-1

(a) For a bandpass response centered at 200 MHz, you want the input impedance into the stub, which is attached in parallel to the line, to be an open circuit at 200 MHz. This is accomplished using a short-circuited stub which is one quarter wavelength long at 200 MHz. A wavelength in the transmission line is

$$\lambda = \frac{0.67 (3 \times 10^8 \text{ m/s})}{200 \text{ MHz}} = 1.005 \text{ m} \quad (3.1)$$

so the stub length is 25.12 cm.

(b) See below:

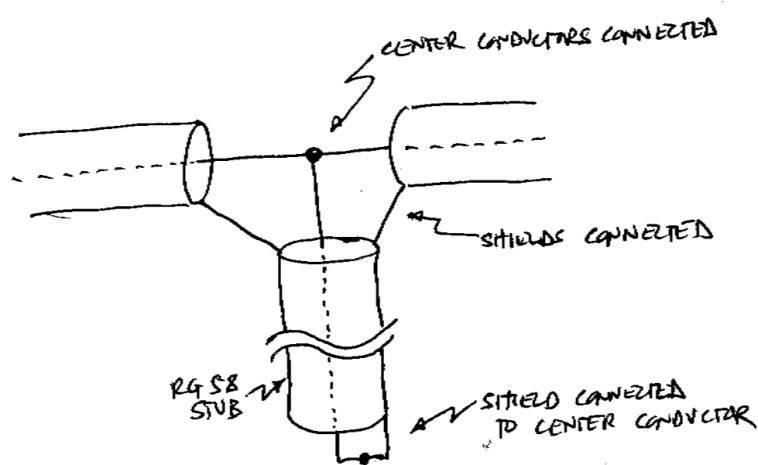

[m0145] [2]

3.17-2

The smallest length for which the imaginary component of the impedance of an open-circuited stub is positive is slightly greater than $\lambda/4$. The imaginary part of the impedance remains positive until the length is slightly less than $\lambda/2$. In this transmission line,

$$\beta = \frac{\omega}{v_p} = \frac{2\pi f}{0.7c} = 89.8 \text{ rad/m}$$

where $f = 3 \text{ GHz}$. Therefore,

$$\lambda = \frac{2\pi}{\beta} = 7 \text{ cm}$$

and so the smallest contiguous range of transmission line length l is

$$\boxed{1.75 \text{ cm} < l < 3.5 \text{ cm}}$$

[m0145] [3]

3.17-3

For zero response centered at $f_c = 1.3$ GHz you want the input impedance into the stub, which is attached in parallel to the line, to be a short circuit at $f = f_c$. This is accomplished using an open-circuited stub that is one quarter wavelength long at $f = f_c$. A wavelength in the transmission line is

$$\lambda = \frac{0.6 (3 \times 10^8 \text{ m/s})}{1.3 \text{ GHz}} = 13.84 \text{ cm} \quad (3.2)$$

so the stub length is 3.46 cm. The characteristic impedance is irrelevant.

[m0091] [1]

3.19-1

From the problem statement, we see that the design will consist of a quarter-wave matching section followed by a line having a characteristic impedance $Z_{02} = 300 \Omega$ – i.e., equal to the load impedance – and the total length will be $l = 5$ cm. The characteristic impedance of the quarter-wave section must be $Z_{01} = \sqrt{Z_S Z_{02}}$, where Z_S is the source output impedance; thus, we have $Z_{01} = 122.5 \Omega$. The length l_1 of the quarter-wave section is $\lambda/4$, where λ is the wavelength in the transmission line. For FR4, we have

$$\lambda = \frac{\lambda_0}{\sqrt{\epsilon_{r,eff}}} = \frac{c/f}{\sqrt{\frac{1}{2}(\epsilon_r + 1)}} = \frac{(3 \times 10^8 \text{ m/s}) / (1.5 \text{ GHz})}{\sqrt{\frac{1}{2}(4.5 + 1)}} = 12.06 \text{ cm}$$

so $l_1 = 3.01$ cm and $l_2 = l - l_1 = 1.99$ cm.

What's left to figure out is the width w of the microstrip lines, which determines the characteristic impedance since $h = 1.6$ mm and $\epsilon_r = 4.5$ are already set. We know that $h/w = 1/2$ gives a characteristic impedance of 50Ω for FR4, so the width of a 50Ω line is $2h = 3.2$ mm. To get the higher characteristic impedance $Z_{01} = 122.5\Omega$, w_1 will have to be smaller than 3.2 mm. An approximate but reasonable solution is simply to assume the characteristic impedance scales with w in the same way (i.e., linearly) as it does in the “wide” ($h/w \ll 1$) case, so

$$w_1 \approx (3.2 \text{ mm}) \frac{50 \Omega}{122.5 \Omega} = 1.3 \text{ mm}$$

and

$$w_2 \approx (3.2 \text{ mm}) \frac{50 \Omega}{300 \Omega} = 0.5 \text{ mm}$$

You could also use the Wheeler (1977) formula or some other equation or reference; however, the increased accuracy is typically irrelevant in practice due to issues such as the large variation in ϵ_r due to manufacturing issues. So, while it's not wrong to take that approach, it's usually not worth the effort if you are able to instead “scale” from a known design as we have done above.

So, your sketch should show the source, followed by 3.01 cm of line which is 1.3 mm wide, followed by 1.09 cm of line which is 0.5 mm wide, followed by the load, as shown in the figure.

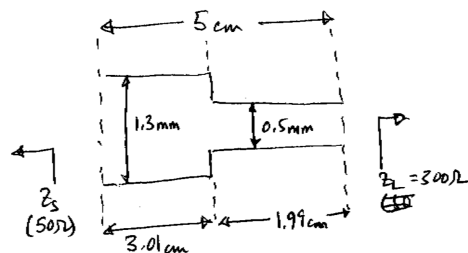

[m0091] [2]

3.19-2

From the problem statement: $Z_L = 200 \Omega$, $l = \lambda/4$, and $Z_0 = 100 \Omega$. Since this is a quarter-wave line,

$$Z_{in} = \frac{Z_0^2}{Z_L} = \boxed{50 \Omega}$$

[m0091] [3]

3.19-3

The problem statement implies that each of the stubs is short-circuited at the end opposite the main line. For this to be a bandpass filter, the magnitude of the input impedance looking into each stub must be very high – nominally infinite – since then the filter structure would be in effect the main line by itself, with no stubs, and would therefore be well-matched at the filter input and output. At any higher or lower frequency the magnitude of the stubs' input impedance can only be less; therefore, the input impedance of the filter would be increasingly mismatched. This results in bandpass response.

The shortest length for which the magnitude of the input impedance of a short-circuited transmission line is infinite is $\lambda/4$. Therefore, $\lambda/4 = 3.38$ mm and subsequently $\lambda = 13.52$ mm in the stub. Therefore, the center frequency is

$$f = \frac{v_p}{\lambda} = \frac{0.6c}{\lambda} = \boxed{13.3 \text{ GHz}}$$

[m0090] [1]

3.20-1

Summarizing the problem statement: $P_{av}^+ = 5$ W and $P_L = 4.6$ W. Therefore, $P_L/P_{av}^+ = 0.92$. From this, we may find the magnitude of the reflection coefficient, $|\Gamma|$, using

$$\frac{P_L}{P_{av}^+} = 1 - |\Gamma|^2$$

We find $|\Gamma| \cong 0.283$ and

$$\text{SWR} = \frac{1 + |\Gamma|}{1 - |\Gamma|} \cong \boxed{1.79}$$

[m0090] [2]

3.20-2

From the problem statement, $\Gamma = 0.3 + j0.4$ and $P_{av}^+ = 3$ W. Therefore,

$$P_L = (1 - |\Gamma|^2) P_{av}^+ = \boxed{2.25 \text{ W}}$$

[m0094] [1]

3.23-1

From the problem statement, we have $f = 220$ MHz, antenna impedance $Z_A = 73 + j42 \Omega$, and characteristic impedance $Z_0 = 50 \Omega$ for both the transmission line and the stub. The input impedance looking into a length d_1 of transmission line terminated in impedance Z_A is

$$Z_1(\beta d_1) = Z_0 \frac{1 + \Gamma e^{-j2\beta d_1}}{1 - \Gamma e^{-j2\beta d_1}} \quad (3.3)$$

where

$$\Gamma = \frac{Z_A - Z_0}{Z_A + Z_0} = 0.2719 + j0.2486 \quad (3.4)$$

The first task is to find the smallest βd_1 such that the real part of $Y_1(\beta d_1) = Z_1^{-1}(\beta d_1)$ equals $Y_0 = Z_0^{-1} = 0.02 \Omega^{-1}$. After a few minutes of trial and error one finds:

$$Y_1(\beta d_1 = 1.345 \text{ rad}) = 0.0200 + j0.0159 \Omega^{-1} \quad (3.5)$$

(You could also do this with a Smith chart if you are so inclined.) The match is accomplished by attaching a stub having input admittance $Y_2 = -j0.0159 \Omega^{-1}$ in parallel with Y_1 , since then the combined admittance will be $Y_1 + Y_2 = Y_0 = Z_0^{-1}$. For a short-circuited stub of length d_2 we would want:

$$Y_2 = -jY_0 \cot \beta d_2 = -j0.0159 \Omega^{-1} \Rightarrow \beta d_2 = 0.900 \text{ rad} \quad (3.6)$$

For an open-circuited stub of length d_2 we would want:

$$Y_2 = +jY_0 \tan \beta d_2 = -j0.0159 \Omega^{-1} \Rightarrow \beta d_2 = 2.471 \text{ rad} \quad (3.7)$$

The short-circuited stub is shorter, so that's the preferred solution. All that remains is to figure out the physical lengths from the electrical lengths. For this, we need to know β . The phase velocity is $v_p = 0.67c$, so

$$\beta = \frac{2\pi}{\lambda} = \frac{2\pi}{0.67c/f} = 6.8771 \text{ rad/m} \quad (3.8)$$

Finally we have the solution:

$$d_1 = \frac{\beta d_1}{\beta} = \frac{1.345 \text{ rad}}{6.877 \text{ rad/m}} = \boxed{19.6 \text{ cm}} \text{ distance from antenna terminals to stub} \quad (3.9)$$

$$d_2 = \frac{\beta d_2}{\beta} = \frac{0.900 \text{ rad}}{6.877 \text{ rad/m}} = \boxed{13.1 \text{ cm}} \text{ stub length} \quad (3.10)$$

and the stub is short-circuited.

[m0094] [2]

3.23-2

In terms of the variables used in the book, the problems statement is indicating that $Y_1 = 0.0128 - j0.0040 \Omega^{-1}$ and that Z_{in} is real-valued. Therefore, $Y_{in} = 1/Z_{in}$ is real-valued, and must be equal to the real part of Y_1 ; i.e., $Y_{in} = 0.0128 \Omega^{-1}$. Therefore, $Z_{in} \cong 78.1 \Omega$, which is the answer to part (a).

The stub is being used to cancel the imaginary part of Y_1 , so $Y_{stub} = +j0.0040 \Omega^{-1}$ and subsequently $Z_{stub} = -j250 \Omega$, which is the answer to part (b).

Chapter 5

Electrostatics

[m0102] [1]

5.1-1

The electric field due to a point charge q is

$$\mathbf{E}(\mathbf{R}) = \hat{\mathbf{R}} \frac{q}{4\pi\epsilon R^2}$$

where \mathbf{R} is the position-free vector pointing from the charge to the field point. From the problem statement, $q = -24$ nC, $\epsilon_r = 2$, and

$$\mathbf{R} = \hat{\mathbf{x}} + \hat{\mathbf{y}}2 + \hat{\mathbf{z}}3 \text{ m}$$

Thus

$$R \triangleq |\mathbf{R}| = \sqrt{1^2 + 2^2 + 3^2} \cong 3.74 \text{ m}$$

$$\hat{\mathbf{R}} \triangleq \frac{\mathbf{R}}{R} \cong \hat{\mathbf{x}}0.267 + \hat{\mathbf{y}}0.534 + \hat{\mathbf{z}}0.802$$

$$\epsilon = \epsilon_r \epsilon_0 = 2 \cdot 8.854 \times 10^{-12} \text{ F/m}$$

Thus

$$\mathbf{E}(\mathbf{R}) \cong \boxed{-\hat{\mathbf{x}}2.06 - \hat{\mathbf{y}}4.12 - \hat{\mathbf{z}}6.18 \text{ V/m}}$$

[m0103] [1]

5.2-1

From the problem statement,

$q_1 = +3 \text{ nC}$ at $\mathbf{r}_1 = -\hat{\mathbf{z}}d$ and

$q_2 = +3 \text{ nC}$ at $\mathbf{r}_2 = +\hat{\mathbf{z}}d$ where $d = 0.5 \text{ m}$;

the field point of interest is $\mathbf{r} = +\hat{\mathbf{x}}x$ where $x = +1.5 \text{ m}$, and

$\epsilon = \epsilon_0 \cong 8.854 \times 10^{-12} \text{ F/m}$.

The electric field intensity due to two point charges is

$$\mathbf{E}(\mathbf{r}) = \frac{1}{4\pi\epsilon} \left[\frac{\mathbf{r} - \mathbf{r}_1}{|\mathbf{r} - \mathbf{r}_1|^3} q_1 + \frac{\mathbf{r} - \mathbf{r}_2}{|\mathbf{r} - \mathbf{r}_2|^3} q_2 \right]$$

In this problem:

$$\mathbf{r} - \mathbf{r}_1 = +\hat{\mathbf{x}}x - (-\hat{\mathbf{z}}d) = +\hat{\mathbf{x}}x + \hat{\mathbf{z}}d$$

$$|\mathbf{r} - \mathbf{r}_1| = \sqrt{x^2 + d^2}$$

$$\mathbf{r} - \mathbf{r}_2 = +\hat{\mathbf{x}}x - (+\hat{\mathbf{z}}d) = +\hat{\mathbf{x}}x - \hat{\mathbf{z}}d$$

$$|\mathbf{r} - \mathbf{r}_2| = \sqrt{x^2 + d^2}$$

Substituting:

$$\mathbf{E}(+\hat{\mathbf{x}}x) = \frac{1}{4\pi\epsilon_0} \left[\frac{+\hat{\mathbf{x}}x + \hat{\mathbf{z}}d}{(x^2 + d^2)^{3/2}} q + \frac{+\hat{\mathbf{x}}x - \hat{\mathbf{z}}d}{(x^2 + d^2)^{3/2}} q \right]$$

where we have made the definition $q \triangleq q_1 = q_2$. Note that the $\hat{\mathbf{z}}$ -directed components cancel, as expected from the symmetry of the problem. Eliminating these components and simplifying:

$$\mathbf{E}(+\hat{\mathbf{x}}x) = \hat{\mathbf{x}} \frac{q}{2\pi\epsilon_0} \frac{x}{(x^2 + d^2)^{3/2}}$$

Now take a moment to confirm that the solution is dimensionally-correct and makes physical sense. Finally, substituting values, we obtain:

$$\mathbf{E}(+\hat{\mathbf{x}}1.5 \text{ m}) \cong \boxed{+\hat{\mathbf{x}} (20.5 \text{ V/m})}$$

For a single charge q_0 at the origin to create this field, we require

$$\hat{\mathbf{x}} \frac{q_0}{4\pi\epsilon_0 x^2} = +\hat{\mathbf{x}} (20.5 \text{ V/m})$$

which yields $q_0 \cong \boxed{+5.12 \text{ nC}}$.

[m0100] [1]

5.3-1

From the problem statement, $\rho_v = Kr^{-2}$ where $K = 2 \text{ C/m}$. From dimensional analysis, it is clear that this is a volume charge density. We seek the total charge Q in a volumetric region \mathcal{V} bounded by the constant-coordinate surfaces $r = a$ and $r = b$ where $a = 1 \text{ m}$ and $b = 2 \text{ m}$. In general,

$$Q = \int_{\mathcal{V}} \rho_v dv$$

In this case, using spherical coordinates:

$$Q = \int_{r=a}^b \int_{\theta=0}^{\pi} \int_{\phi=0}^{2\pi} \left(\frac{K}{r^2} \right) (r^2 \sin \theta \, dr \, d\theta \, d\phi)$$

Factoring into separate integrals:

$$Q = K \left[\int_{r=a}^b dr \right] \left[\int_{\theta=0}^{\pi} \sin \theta \, d\theta \right] \left[\int_{\phi=0}^{2\pi} d\phi \right]$$

Evaluating the integrals:

$$Q = K [b - a] [2] [2\pi] = 4\pi K (b - a)$$

This a good point at which to check for dimensional consistency (i.e., correct units).

Using the given values of K , a , and b we obtain $Q \cong \boxed{25.1 \text{ C}}$.

5.4-1

Interpreting the problem statement:

$\rho_{s,1} \triangleq +4 \text{ nC/m}^2$ for sheet in the $x = 0$ plane. Let the field from this sheet be \mathbf{E}_1 .

$\rho_{s,2} \triangleq +16 \text{ nC/m}^2$ for sheet in the $y = 0$ plane. Let the field from this sheet be \mathbf{E}_2 .

$\rho_{s,3} \triangleq +64 \text{ nC/m}^2$ for sheet in the $z = 0$ plane. Let the field from this sheet be \mathbf{E}_3 .

Also, $\epsilon = 2\epsilon_0$.

The electric field intensity due to a single sheet of charge having charge density ρ_s in the $z = 0$ plane is worked out in the book. It is:

$$+\hat{\mathbf{z}} \frac{\rho_s}{2\epsilon} \text{sgn}z$$

This corresponds to the third sheet of charge above. Since the region of interest is $z > 0$:

$$\mathbf{E}_3 = +\hat{\mathbf{z}} \frac{\rho_{s,3}}{4\epsilon_0}$$

Similarly,

$$\mathbf{E}_1 = +\hat{\mathbf{x}} \frac{\rho_{s,1}}{4\epsilon_0}$$

$$\mathbf{E}_2 = +\hat{\mathbf{y}} \frac{\rho_{s,2}}{4\epsilon_0}$$

The total field is the sum of these three fields. Thus:

$$\mathbf{E} = \hat{\mathbf{x}} \frac{\rho_{s,1}}{4\epsilon_0} + \hat{\mathbf{y}} \frac{\rho_{s,2}}{4\epsilon_0} + \hat{\mathbf{z}} \frac{\rho_{s,3}}{4\epsilon_0}$$

Substituting values, we obtain:

$$\mathbf{E} \cong \boxed{\hat{\mathbf{x}} (113 \text{ V/m}) + \hat{\mathbf{y}} (452 \text{ V/m}) + \hat{\mathbf{z}} (1807 \text{ V/m})}$$

[m0014] [1]

5.5-1

Note $\mathbf{F}_{12} = Q_2 \mathbf{E}_1$ where \mathbf{E}_1 is the electric field intensity associated with Q_1 . Thus:

$$\mathbf{E}_1 = \frac{\mathbf{F}_{12}}{Q_2} = \hat{\mathbf{R}}_{12} \frac{Q_1}{4\pi\epsilon R_{12}^2}$$

We can write this in terms of the electric flux density, assuming a isotropic and homogenous medium:

$$\mathbf{D}_1 = \epsilon \mathbf{E}_1 = \hat{\mathbf{R}}_{12} \frac{Q_1}{4\pi R_{12}^2}$$

Now let's put Q_1 at the origin, and let \mathcal{S} be a sphere of radius a centered at the origin. Then, the left hand side of Gauss' Law is:

$$\oint_{\mathcal{S}} \mathbf{D} \cdot d\mathbf{s} = \int_{\theta=0}^{\pi} \int_{\phi=0}^{2\pi} \left[\hat{\mathbf{r}} \frac{Q_1}{4\pi a^2} \right] \cdot [\hat{\mathbf{r}} a^2 \sin \theta \, d\theta \, d\phi] = \frac{Q_1}{4\pi} \int_{\theta=0}^{\pi} \int_{\phi=0}^{2\pi} \sin \theta \, d\theta \, d\phi = Q_1$$

Because we put Q_1 at the origin and defined \mathcal{S} to surround it, $Q_{encl} = Q_1$, which is what we expect from Gauss' Law. Therefore, Coulomb's Law is a solution to – a special case really – of Gauss' Law.

You might be inclined to object on the grounds that Gauss' Law doesn't say anything about force or electric field intensity. This is true! However, electric field intensity is *defined* by force; i.e., $\mathbf{E}_1 = \mathbf{F}_{12}/Q_2$ is a definition for \mathbf{E}_1 , and not derived from something else. Similarly, $\mathbf{D}_1 = \epsilon \mathbf{E}_1$ is a definition for \mathbf{D}_1 , and not derived from something else. So, Gauss' Law is as fundamental as it gets.

[m0014] [4]

5.5-2

By symmetry, there can be no variation in the z or ϕ dimensions. Therefore, our answer can depend only on ρ . The three regions to consider are inside the inner surface of the shell ($\rho < 1$ m), inside the shell itself ($1 \leq \rho < 3$ m), and outside the outer surface of the shell ($\rho > 3$ m).

The integral form of Gauss' Law is:

$$\int_{\mathcal{S}} \mathbf{D} \cdot d\mathbf{s} = Q_{encl} \quad (5.1)$$

where \mathcal{S} is any closed surface. Since we are asked for electric field intensity, we can use $\mathbf{D} = \epsilon \mathbf{E}$ to obtain:

$$\int_{\mathcal{S}} \mathbf{E} \cdot d\mathbf{s} = \frac{1}{\epsilon} Q_{encl} . \quad (5.2)$$

Note that we use ϵ as opposed to ϵ_0 , since the latter infers free space conditions, and we haven't been told that.

For $\rho < 1$ m, $Q_{encl} = 0$; i.e., there is no surface that we can define that encloses charge. Combined with the symmetry argument, we have that $\boxed{\mathbf{E} = 0}$ in this region.

For $1 \leq \rho < 3$ m, Q_{encl} depends on ρ . Combined with the symmetry argument, we have $\mathbf{E}(\rho) = \hat{\rho} E(\rho)$. Thus, a good choice for \mathcal{S} is a cylinder centered on the z axis. This gives us:

$$\int_{\phi=0}^{2\pi} \int_{z=-L/2}^{+L/2} \hat{\rho} E(\rho) \cdot \hat{\rho} \rho d\phi dz + 0 = \frac{1}{\epsilon} \int_{\rho=1}^{\rho} \int_{\phi=0}^{2\pi} \int_{z=-L/2}^{+L/2} \rho_v d\rho \rho d\phi dz \quad (5.3)$$

where “+0” on the left hand side is the contribution from the constant- z surfaces (the “end caps”) of the cylinder – zero because the normal to those surfaces ($\hat{\mathbf{z}}$) is perpendicular to \mathbf{E} . Now evaluating:

$$E(\rho) 2\pi\rho L = \frac{1}{\epsilon} \rho_v \pi L (\rho^2 - 1 \text{ m}^2) . \quad (5.4)$$

Finally:

$$\boxed{\mathbf{E}(\rho) = \hat{\rho} \frac{\rho_v}{2\epsilon} \left(\rho - \frac{1 \text{ m}^2}{\rho} \right)} \text{ in this region.} \quad (5.5)$$

Assuming ρ_v is in C/m³ and ϵ is in F/m, $\mathbf{E}(\rho)$ will be in V/m. However, if you say simply “1” as opposed to “1 m²” in the above expression, then you must indicate the units of ρ (being meters) as well. In electromagnetics, a powerful (but unappreciated) technique for checking your work is to make sure your solution has the right units. This is called *dimensional analysis*. You should be able to substitute units for each of the quantities in the above solution and find that the result has units of V/m – can you do this?

For $\rho > 3$ m, Q_{encl} is constant at the maximum value (since all the charge has been enclosed), but $E(\rho)$ is still a variable function of ρ . Thus, the left hand side of Equation 5.4 remains the same, but the right hand side is evaluated at $\rho = 3$ m. This yields:

$$E(\rho) 2\pi\rho L = \frac{1}{\epsilon} \rho_v \pi L \cdot 8 \text{ m}^2 . \quad (5.6)$$

Thus:

$$\boxed{\mathbf{E}(\rho) = \hat{\rho} \frac{\rho_v}{\epsilon} \frac{4 \text{ m}^2}{\rho}} \text{ in this region.} \quad (5.7)$$

Suggestion: Try dimensional analysis on this solution. Can you see why it is important to say “4 m²” as opposed to just “4”?

5.5-3

By symmetry, there can be no variation in the θ or ϕ dimensions. Therefore, our answer can depend *only* on r . The three regions to consider are inside the inner surface of the shell ($r < 2$ m), inside the shell itself ($2 \leq r < 4$ m), and outside the outer surface of the shell ($r > 4$ m).

The integral form of Gauss' Law is:

$$\int_{\mathcal{S}} \mathbf{D} \cdot d\mathbf{s} = Q_{\text{enclosed}} \quad (5.8)$$

where \mathcal{S} is any closed surface. Since we are asked for electric field intensity, we can use $\mathbf{D} = \epsilon \mathbf{E}$ to obtain:

$$\int_{\mathcal{S}} \mathbf{E} \cdot d\mathbf{s} = \frac{1}{\epsilon} Q_{\text{enclosed}} . \quad (5.9)$$

Note that we use ϵ as opposed to ϵ_0 , since the latter infers free space conditions, and we haven't been told that.

For $r < 2$ m, $Q_{\text{enclosed}} = 0$; i.e., there is no surface that we can define that encloses charge. Therefore, $\boxed{\mathbf{E} = 0}$ in this region.

For $2 \leq r < 4$ m, Q_{enclosed} depends on r . Combined with the symmetry argument, we have $\mathbf{E}(r) = \hat{\mathbf{r}}E(r)$. Thus, a good choice for \mathcal{S} is a sphere centered at the origin. This gives us:

$$\int_{\theta=0}^{\pi} \int_{\phi=0}^{2\pi} \hat{\mathbf{r}}E(r) \cdot \hat{\mathbf{r}} r^2 \sin \theta d\theta d\phi = \frac{1}{\epsilon} \int_{r=2}^r \int_{\theta=0}^{\pi} \int_{\phi=0}^{2\pi} \rho_v r^2 \sin \theta dr d\theta d\phi \quad (5.10)$$

Now evaluating:

$$4\pi r^2 E(r) = \frac{\rho_v}{\epsilon} \frac{4\pi}{3} (r^3 - [8 \text{ m}^3]) . \quad (5.11)$$

Finally:

$$\boxed{\mathbf{E}(r) = \hat{\mathbf{r}} \frac{\rho_v}{3\epsilon} \left(r - \frac{8 \text{ m}^3}{r^2} \right)} \text{ in this region.} \quad (5.12)$$

Assuming ρ_v is in units of C/m³ and ϵ is in F/m, $\mathbf{E}(\rho)$ will be in V/m. However, if you say simply "8" as opposed to "8 m³" in the above expression, then you *must* indicate the units of r (being meters) as well! In electromagnetics, a powerful (but sadly, unappreciated) technique for checking your work is to make sure your solution has the right units. This is called *dimensional analysis*. You should be able to substitute units for each of the quantities in the above solution and find that the result has units of V/m – can you do this?

Also note that you have a second way to check your solution – it must be equal to the solution for the first region for $r = 2$ m. Note that it is.

For $r > 4$ m, $Q_{enclosed}$ is constant at the maximum value (since all the charge has been enclosed), but $E(r)$ is still a variable function of r . Thus, the left hand side of Equation 5.11 remains the same, but the right hand side is evaluated at $r = 4$ m. This yields:

$$4\pi r^2 E(r) = \frac{\rho_v}{\epsilon} \frac{4\pi}{3} (56 \text{ m}^3) . \quad (5.13)$$

Thus:

$$\boxed{\mathbf{E}(r) = \hat{\mathbf{r}} \frac{\rho_v}{3\epsilon} \frac{56 \text{ m}^3}{r^2}} \text{ in this region.} \quad (5.14)$$

Suggestion: Try dimensional analysis on this solution. Can you see why it is important to say “56 m³” as opposed to just “56”? Also, confirm that your answer agrees with the Region 2 answer for $r = 4$ m.

[m0014] [3]

5.5-4

(a) A , B , and C have units of $\boxed{\text{V/m}^4, \text{V/m}^3, \text{ and } \text{V/m}^2}$, respectively.

(b) According to the integral form of Gauss' Law:

$$Q_{encl} = \oint_{\mathcal{S}} \mathbf{D} \cdot d\mathbf{s} = \epsilon_0 \oint_{\mathcal{S}} \mathbf{E} \cdot d\mathbf{s}$$

Here, \mathcal{S} is the surface of the box-shaped region, and $d\mathbf{s}$ is the normal to each of the six sides. This integral is easiest to handle as the sum of integrals over each side, since then $d\mathbf{s}$ will be constant over each of these integrals. Here we go:

$$\begin{aligned} \int_{-x \text{ side}} \mathbf{E} \cdot (-\hat{\mathbf{x}} dy dz) &= - \int_{y=0}^{y=+1} \int_{z=-1}^{z=0} A (-1) z^2 dy dz = +\frac{1}{3}A \\ \int_{+x \text{ side}} \mathbf{E} \cdot (+\hat{\mathbf{x}} dy dz) &= \int_{y=0}^{y=+1} \int_{z=-1}^{z=0} A (+1) z^2 dy dz = +\frac{1}{3}A \\ \int_{-y \text{ side}} \mathbf{E} \cdot (-\hat{\mathbf{y}} dx dz) &= - \int_{x=-1}^{x=+1} \int_{z=-1}^{z=0} (-B (0) z) dx dz = 0 \\ \int_{+y \text{ side}} \mathbf{E} \cdot (+\hat{\mathbf{y}} dx dz) &= \int_{x=-1}^{x=+1} \int_{z=-1}^{z=0} (-B (+1) z) dx dz = +B \\ \int_{-z \text{ side}} \mathbf{E} \cdot (-\hat{\mathbf{z}} dx dy) &= - \int_{x=-1}^{x=+1} \int_{y=0}^{y=+1} Cx dx dy = 0 \\ \int_{+z \text{ side}} \mathbf{E} \cdot (+\hat{\mathbf{z}} dx dy) &= \int_{x=-1}^{x=+1} \int_{y=0}^{y=+1} Cx dx dy = 0 \end{aligned}$$

So we find:

$$Q_{encl} = \epsilon_0 \left(\frac{1}{3}A + \frac{1}{3}A + 0 + B + 0 + 0 \right) = \epsilon_0 \left(\frac{2}{3}A + B \right)$$

having units of Coulombs if ϵ_0 is in F/m and the dimensions are all in meters. The chances for units-related confusion is reduced if consider what has actually happened in the integration and say specifically:

$$\boxed{Q_{encl} = \epsilon_0 \left[\left(\frac{2}{3} \text{ m}^5 \right) A + (1 \text{ m}^4) B \right]}$$

[m0149] [1]

5.6-1

This is essentially the same problem shown as an example in the book, for which the electric field intensity was found to be

$$\mathbf{E} = \hat{\rho} \frac{\rho_l}{2\pi\epsilon\rho}$$

where here $\rho_l = -2.1$ mC/m and ρ is the distance from the z -axis. The electric flux density is $\mathbf{D} = \epsilon\mathbf{E}$, so the permittivity doesn't matter. The result is:

$$\mathbf{D} = \hat{\rho} \frac{\rho_l}{2\pi\rho} \cong \boxed{-\hat{\rho} \frac{334 \mu\text{C/m}}{\rho}}$$

[m0045] [1]

5.7-1

From Gauss' Law, $\rho_v = \nabla \cdot \mathbf{D} = \nabla \cdot (\epsilon_0 \epsilon_r \mathbf{E}) = \epsilon_0 \epsilon_r \nabla \cdot \mathbf{E}$. Calculating the divergence:

$$\begin{aligned}\nabla \cdot \mathbf{E} &= \frac{\partial}{\partial x} ((6 \text{ V/m}^2)x) + \frac{\partial}{\partial y} ((2 \text{ V/m}^3)yz) + \frac{\partial}{\partial z} ((1 \text{ V/m}^3)xy) \\ &= (6 \text{ V/m}^2)(1) + (2 \text{ V/m}^3)(z) + (1 \text{ V/m}^3)(0) \\ &= (6 \text{ V/m}^2) + (2 \text{ V/m}^3)z\end{aligned}$$

$\epsilon_0 \cong 8.854 \times 10^{-12} \text{ F/m}$ and $\epsilon_r = 4.5$, so

$$\rho_v = \boxed{239.1 \text{ pC/m}^3 + (79.7 \text{ pC/m}^4)z}$$

[m0045] [2]

5.7-2

(a) $\rho_v = \nabla \cdot \mathbf{D} = \epsilon_0 \nabla \cdot \mathbf{E}$. Here it's easiest to use Cartesian coordinates, for which

$$\nabla = \hat{\mathbf{x}} \frac{\partial}{\partial x} + \hat{\mathbf{y}} \frac{\partial}{\partial y} + \hat{\mathbf{z}} \frac{\partial}{\partial z}$$

so we have

$$\begin{aligned} \rho_v &= \epsilon_0 \left[\hat{\mathbf{x}} \frac{\partial}{\partial x} + \hat{\mathbf{y}} \frac{\partial}{\partial y} + \hat{\mathbf{z}} \frac{\partial}{\partial z} \right] \cdot [\hat{\mathbf{x}} (2 \text{ V/m}) \sin x \cos y - \hat{\mathbf{y}} (2 \text{ V/m}) \cos x \sin y] \\ &= \epsilon_0 [(2 \text{ V/m}^2) \cos x \cos y - (2 \text{ V/m}^2) \cos x \cos y] = \boxed{0} \end{aligned}$$

This is an example of a *divergence-free field*. It seems that there can be an electric field even when there is no charge. This means simply that the source charge must lie entirely outside the region being considered.

(b) In this case we have

$$\begin{aligned} \rho_v &= \epsilon_0 \left[\hat{\mathbf{x}} \frac{\partial}{\partial x} + \hat{\mathbf{y}} \frac{\partial}{\partial y} + \hat{\mathbf{z}} \frac{\partial}{\partial z} \right] \cdot [\hat{\mathbf{x}} (3 \text{ V/m}) \cos xy + \hat{\mathbf{y}} (3 \text{ V/m}) \sin xy] \\ &= (3 \text{ V/m}^3) \epsilon_0 [-y \sin xy + x \cos xy] \end{aligned}$$

which has the expected units of C/m³.

[m0045] [3]

5.7-3

(a) A , B , and C have units of $\boxed{\text{V/m}^4, \text{V/m}^3, \text{and } \text{V/m}^2}$, respectively.

(c) According to the differential form of Gauss' Law, we have for this problem:

$$\rho_v = \epsilon_0 \nabla \cdot \mathbf{E} = \epsilon_0 \left[\frac{\partial}{\partial x}(Axz^2) + \frac{\partial}{\partial y}(-Byz) + \frac{\partial}{\partial z}(Cx) \right] = \epsilon_0 [Az^2 - Bz + 0] .$$

This is charge density as a function of position. The enclosed charge is obtained by integrating over the region of interest:

$$Q_{encl} = \int_{\mathcal{V}} \rho_v \, dv = \int_{x=-1}^{x=+1} \int_{y=0}^{y=+1} \int_{z=-1}^{z=0} \epsilon_0 (Az^2 - Bz) \, dx \, dy \, dz$$

The integrations over x and y factor out and are equal to 2 and 1 respectively. What's left is:

$$Q_{encl} = (2)(1)\epsilon_0 \int_{z=-1}^{z=+1} (Az^2 - Bz) \, dz = \boxed{Q_{encl} = \epsilon_0 \left[\left(\frac{2}{3} \text{ m}^5 \right) A + (1 \text{ m}^4) B \right]}$$

Note that this result agrees with the result obtained using the more direct approach of using the *integral* form of Gauss' Law. You should note that the reason the results are the same is not really related to electromagnetics, but rather due to the Divergence Theorem (of mathematics), which relates the behavior of a vector field in a volume to the behavior of that same vector field over the enclosing surface.

[m0061] [1]

5.8-1

The change in the energy of the system resulting from moving the particle a small distance $\hat{\mathbf{1}}\Delta l$ is:

$$\Delta W \approx -q\mathbf{E} \cdot \hat{\mathbf{1}}\Delta l$$

Power P is energy per time, so the power required to do this is:

$$P \approx \frac{\Delta W}{\Delta t} \approx -q\mathbf{E} \cdot \frac{\hat{\mathbf{1}}\Delta l}{\Delta t}$$

where Δt is the time required for the particle to traverse the distance. Note that in the limit as $\Delta t \rightarrow 0$, $\hat{\mathbf{1}}\Delta l/\Delta t$ is the velocity \mathbf{v} of the particle. Taking the limit and making the substitution,

$$P = -q\mathbf{E} \cdot \mathbf{v}$$

This is the “instantaneous power” required at time t and, through t , the position $\mathbf{r}(t)$.

Interpreting the problem statement: $q = -4$ mC;

$\mathbf{E} = E_0\hat{\mathbf{z}}$, where $E_0 = 3$ V/m; and

$\mathbf{r}(t) = \hat{\mathbf{x}}a \cos \omega t + \hat{\mathbf{y}}b \sin \omega t + \hat{\mathbf{z}}ct$, where $a = b = 2$ m, $\omega = \pi$ rad/s, and $c = 4$ m/s.

Note

$$\mathbf{v} \triangleq \frac{d}{dt}\mathbf{r}(t) = -\hat{\mathbf{x}}a\omega \sin \omega t + \hat{\mathbf{y}}b\omega \cos \omega t + \hat{\mathbf{z}}c$$

Therefore,

$$P = -q\mathbf{E} \cdot \mathbf{v} = -qE_0c = -(-4 \text{ mC})(3 \text{ V/m})(4 \text{ m/s}) = \boxed{48 \text{ mW}}$$

[m0064] [2]

5.12-1

Let us arbitrarily assume the charge is aligned along the z axis. Then the electric field intensity is given by

$$\mathbf{E}(\rho) = \hat{\rho} \frac{\rho_l}{2\pi\epsilon\rho} . \quad (5.15)$$

The potential difference is:

$$V_{21} = - \int_{\text{point 1}}^{\text{point 2}} \mathbf{E} \cdot d\hat{\mathbf{l}} = - \int_{\rho_1}^{\rho_2} \hat{\rho} \frac{\rho_l}{2\pi\epsilon\rho} \cdot \hat{\rho} d\rho = \boxed{\frac{\rho_l}{2\pi\epsilon} \ln \frac{\rho_1}{\rho_2}} . \quad (5.16)$$

[m0064] [1]

5.12-2

The electric field intensity resulting from a single line of uniform charge density is given by

$$\mathbf{E}(\mathbf{R}) = \hat{\mathbf{R}} \frac{\rho_l}{2\pi\epsilon R} . \quad (5.17)$$

where R is the distance between the point of interest and closest point on the line, $\hat{\mathbf{R}}$ points from that point on the line to the point of interest, and $\mathbf{R} = \hat{\mathbf{R}}R$.

If we have two such lines of charge, then by superposition we could write:

$$\mathbf{E}(\mathbf{R}) = \hat{\mathbf{R}}_1 \frac{\rho_l}{2\pi\epsilon R_1} + \hat{\mathbf{R}}_2 \frac{\rho_l}{2\pi\epsilon R_2} . \quad (5.18)$$

where the subscripts “1” and “2” refer to the geometry relative to the first and second lines of charge, respectively. In this problem, the lines of charge and the point of interest all lie in the $x - y$ ($z = 0$) plane. Since this is the case we may write simply:

$$\mathbf{E}(x, y) = \hat{\mathbf{x}} \frac{\rho_l}{2\pi\epsilon x} + \hat{\mathbf{y}} \frac{\rho_l}{2\pi\epsilon y} \quad \text{for } z = 0. \quad (5.19)$$

The potential difference is:

$$V_{21} = - \int_{\text{point 1}}^{\text{point 2}} \mathbf{E} \cdot d\mathbf{l} . \quad (5.20)$$

Remember that the answer should be the same for *any* path between the points, so you might as well choose one that makes the problem simple. Here’s the result using one of two equally-easy paths:

$$V_{21} = - \int_{x=x_1}^{x_2} \left[\hat{\mathbf{x}} \frac{\rho_l}{2\pi\epsilon x} + \hat{\mathbf{y}} \frac{\rho_l}{2\pi\epsilon y_2} \right] \cdot \hat{\mathbf{x}} dx - \int_{y=y_1}^{y_2} \left[\hat{\mathbf{x}} \frac{\rho_l}{2\pi\epsilon x_1} + \hat{\mathbf{y}} \frac{\rho_l}{2\pi\epsilon y} \right] \cdot \hat{\mathbf{y}} dy \quad (5.21)$$

That is, first move from (2, 4) m to (1, 4) m along the $y = y_2 = 4$ m line, and then move from (1, 4) m to (1, 1) m along the $x = x_1 = 1$ m line. Evaluating:

$$V_{21} = - \frac{\rho_l}{2\pi\epsilon} \left[\ln \left(\frac{x_2}{x_1} \right) + \ln \left(\frac{y_2}{y_1} \right) \right] = + \frac{\rho_l}{2\pi\epsilon} \left[\ln \left(\frac{x_1}{x_2} \right) + \ln \left(\frac{y_1}{y_2} \right) \right] = \boxed{0.331 \frac{\rho_l}{\epsilon}} . \quad (5.22)$$

Here, you can check your results using dimensional analysis (C/m divided by F/m gives C/F = V). You can also check that the sign is correct: Point 2 is closer to both lines of charge than point 1, so when the charge is positive, work is being done and the potential difference is positive. Said differently, the potential at point 2 is higher than the potential at point 1.

[m0063] [1]

5.14-1

To begin, it will be convenient to first convert \mathbf{r}_0 from Cartesian to spherical coordinates. Here we go:

$$r_0 = \sqrt{x_0^2 + y_0^2 + z_0^2} \cong 5.38 \text{ cm}$$

$$\theta_0 = \arccos(z_0/r_0) \cong 42.0^\circ$$

$$\phi_0 = \arctan(y_0/x_0) \cong 56.3^\circ$$

(a)

$$V(\mathbf{r}_0) = V_0 r_0^2 \cos \theta_0 \cong \boxed{10.8 \text{ mV}}$$

(b)

$$\mathbf{E} = -\nabla V = -\left(\hat{\mathbf{r}} \frac{\partial}{\partial r} + \hat{\theta} \frac{1}{r} \frac{\partial}{\partial \theta} + 0\right) V$$

The third term in the gradient is zero because V in this problem does not vary with ϕ . Continuing:

$$\mathbf{E} = -\hat{\mathbf{r}} \frac{\partial V}{\partial r} - \hat{\theta} \frac{1}{r} \frac{\partial V}{\partial \theta} = -\hat{\mathbf{r}} 2V_0 r \cos \theta + \hat{\theta} V_0 r \sin \theta$$

So:

$$\mathbf{E}(\mathbf{r}_0) \cong \boxed{-\hat{\mathbf{r}} 400 + \hat{\theta} 180 \text{ mV/m}}$$

(c)

$$\rho_v = \nabla \cdot \mathbf{D} = \epsilon_0 \nabla \cdot \mathbf{E} = \epsilon_0 \left[\frac{1}{r^2} \frac{\partial}{\partial r} (r^2 E_r) + \frac{1}{r \sin \theta} \frac{\partial}{\partial \theta} (E_\theta \sin \theta) + 0 \right]$$

where E_r and E_θ are the $\hat{\mathbf{r}}$ - and $\hat{\theta}$ -directed components of \mathbf{E} . The third term in the divergence is zero because \mathbf{E} in this problem does not vary with ϕ . Note:

$$\frac{1}{r^2} \frac{\partial}{\partial r} (r^2 E_r) = \frac{1}{r^2} \frac{\partial}{\partial r} (r^2 (-2V_0 r \cos \theta)) = \frac{1}{r^2} \frac{\partial}{\partial r} (-2V_0 r^3 \cos \theta) = \frac{1}{r^2} (-6V_0 r^2 \cos \theta) = -6V_0 \cos \theta$$

and

$$\begin{aligned} \frac{1}{r \sin \theta} \frac{\partial}{\partial \theta} (E_\theta \sin \theta) &= \frac{1}{r \sin \theta} \frac{\partial}{\partial \theta} ((V_0 r \sin \theta) \sin \theta) = \frac{1}{r \sin \theta} \frac{\partial}{\partial \theta} (V_0 r \sin^2 \theta) = \frac{1}{r \sin \theta} (2V_0 r \sin \theta \cos \theta) \\ &= 2V_0 \cos \theta \end{aligned}$$

Continuing:

$$\rho_v = \epsilon_0 [-6V_0 \cos \theta + 2V_0 \cos \theta] = -4V_0 \epsilon_0 \cos \theta$$

(Good time for a units check...) At the point of interest:

$$\rho_v(\mathbf{r}_0) \cong \boxed{-131 \text{ pC/m}^3}$$

[m0063] [2]

5.14-2

From the problem statement,

$$V(\mathbf{r}) = V_0 r^{-1/2}$$

where $V_0 \triangleq 4 \text{ V} \cdot \text{m}^{1/2}$. So:

$$\begin{aligned} E(\mathbf{r}) &= -\nabla V(\mathbf{r}) \\ &= -\hat{\mathbf{r}} \frac{\partial}{\partial r} V_0 r^{-1/2} + \text{terms that go to zero because } \frac{\partial}{\partial \theta} = \frac{\partial}{\partial \phi} = 0 \\ &= -\hat{\mathbf{r}} V_0 \left(-\frac{1}{2} r^{-3/2} \right) \\ &= +\hat{\mathbf{r}} \frac{V_0}{2} r^{-3/2} \\ &= \boxed{+\hat{\mathbf{r}} (2 \text{ V} \cdot \text{m}^{1/2}) r^{-3/2}} \end{aligned}$$

Note that the answer is dimensionally correct (and unambiguously so).

[m0067] [1]

5.15-1

Poisson's Equation is

$$\nabla^2 V = -\frac{\rho_v}{\epsilon} . \quad (5.23)$$

The geometry of the problem suggests cartesian coordinates, and symmetry such that $\partial V/\partial y = \partial V/\partial z = 0$ is implied. Thus, the above equation becomes:

$$\frac{d^2}{dx^2} V(x) = -\frac{\rho_v(x)}{\epsilon} . \quad (5.24)$$

Integrating both sides with respect to x we have

$$\frac{d}{dx} V(x) = -\frac{1}{\epsilon} \int_{-\infty}^x \rho_v(x) dx . \quad (5.25)$$

Integrating both sides again with respect to x we have

$$V(x) = -\frac{1}{\epsilon} \int_{-\infty}^x \left[\int_{-\infty}^x \rho_v(x) dx \right] dx . \quad (5.26)$$

The first chore is to take care of that sequence of integrations. We begin with mathematical restatement of the given volume charge density:

$$\rho_v(x) = \begin{cases} 0 & , -\infty \leq x < -b \\ -a & , -b \leq x < 0 \\ +a & , 0 \leq x \leq +b \\ 0 & , +b < x \leq -\infty \end{cases} \quad (5.27)$$

Integrating once:

$$\int_{-\infty}^x \rho_v(x) dx = \begin{cases} 0 & , -\infty \leq x < -b \\ -a(x+b) & , -b \leq x \leq 0 \\ +ax - ab & , 0 < x \leq +b \\ 0 & , +b < x \leq -\infty \end{cases} \quad (5.28)$$

If you have a hard time seeing this, consider sketching $\rho_v(x)$ and then doing the integration graphically. Integrating the second time:

$$\int_{-\infty}^x \left[\int_{-\infty}^x \rho_v(x) dx \right] dx = \begin{cases} 0 & , -\infty \leq x < -b \\ -(a/2)x^2 - abx - ab^2/2 & , -b \leq x \leq 0 \\ +(a/2)x^2 - abx - ab^2/2 & , 0 < x \leq +b \\ -ab^2 & , +b < x \leq -\infty \end{cases} \quad (5.29)$$

Substituting this into Equation 5.26 we obtain:

$$V(x) = \frac{1}{\epsilon} \begin{cases} 0 & , -\infty \leq x < -b \\ +(a/2)x^2 + abx + ab^2/2 & , -b \leq x \leq 0 \\ -(a/2)x^2 + abx + ab^2/2 & , 0 < x \leq +b \\ ab^2 & , +b < x \leq -\infty \end{cases} \quad (5.30)$$

Now check your answer. First, as always, check that it is dimensionally correct. Second, note that $V(x)$ should be a continuous function of x , since integration over any function (specifically excluding the impulse or “delta” function) results in a continuous function.

To find the volume charge density a in terms of V , we simply evaluate:

$$V_d = V(x = +b) - V(x = -b) = \frac{ab^2}{\epsilon} - 0 = \frac{ab^2}{\epsilon} . \quad (5.31)$$

and solve for a :

$$\boxed{a = \frac{\epsilon V_d}{b^2}} . \quad (5.32)$$

Given the relative permittivity of silicon $\epsilon_r \approx 12$, $b = 100 \mu\text{m}$, and $V_d = 0.4 \text{ V}$, we find

$$\boxed{a = 4.25 \text{ mC/m}^3} .$$

[m0067] [2]

5.15-2

The symmetry of this problem suggests a solution in spherical coordinates. Laplace's Equation in spherical coordinates is:

$$\nabla^2 V = \frac{1}{r^2} \frac{\partial}{\partial r} \left(r^2 \frac{\partial V}{\partial r} \right) + \frac{1}{r^2 \sin \theta} \frac{\partial}{\partial \theta} \left(\sin \theta \frac{\partial V}{\partial \theta} \right) + \frac{1}{r^2 \sin^2 \theta} \frac{\partial^2 V}{\partial \phi^2} = 0 \quad (5.33)$$

The symmetry of the problem also requires that the potential V not vary with respect to θ or ϕ ; in other words:

$$\frac{\partial V}{\partial \theta} = \frac{\partial V}{\partial \phi} = 0 . \quad (5.34)$$

Thus, V is a function of r only, and Laplace's Equation simplifies to:

$$\frac{1}{r^2} \frac{\partial}{\partial r} \left(r^2 \frac{\partial}{\partial r} V(r) \right) = 0 \quad (5.35)$$

Multiplying through by r^2 and then integrating with respect to r , we obtain:

$$r^2 \frac{\partial}{\partial r} V(r) = C , \quad (5.36)$$

where C is an arbitrary constant. Now dividing through by r^2 and integrating with respect to r again, we obtain:

$$V(r) = -\frac{C_1}{r} + C_2 , \quad (5.37)$$

where C_1 and C_2 are constants that can be determined by boundary conditions. Applying the boundary conditions, we obtain:

$$V(r = 1 \text{ m}) = -\frac{C_1}{1 \text{ m}} + C_2 = 100 \text{ V} , \text{ and} \quad (5.38)$$

$$V(r = 3 \text{ m}) = -\frac{C_1}{3 \text{ m}} + C_2 = 20 \text{ V} . \quad (5.39)$$

A simple way to solve for C_1 and C_2 here is simply to subtract the second equation from the first equation, which eliminates C_2 , then solve for C_1 and use that result to solve for C_2 . One finds $C_1 = -120 \text{ V}\cdot\text{m}$ and $C_2 = -20 \text{ V}$. Thus:

$$\boxed{V(r) = +\frac{120 \text{ V}\cdot\text{m}}{r} - 20 \text{ V}} , \quad 1 \text{ m} \leq r \leq 3 \text{ m} . \quad (5.40)$$

Note that an answer like " $V(r) = 120/r - 20$ " is dangerously ambiguous, unless you specify *as part of the answer* that r must be in meters and V will be in volts.

[m0068] [1]

5.16-1

The symmetry of this problem suggests a solution in cylindrical coordinates. Laplace's Equation in cylindrical coordinates is:

$$\nabla^2 V = \frac{1}{\rho} \frac{\partial}{\partial \rho} \left(\rho \frac{\partial V}{\partial \rho} \right) + \frac{1}{\rho^2} \frac{\partial^2 V}{\partial \phi^2} + \frac{\partial^2 V}{\partial z^2} = 0 \quad (5.41)$$

The symmetry of the problem also requires that the potential V not vary with respect to ϕ or z ; in other words:

$$\frac{\partial V}{\partial \phi} = \frac{\partial V}{\partial z} = 0 . \quad (5.42)$$

Thus, V is a function of ρ only, and Laplace's Equation simplifies to:

$$\frac{\partial}{\partial \rho} \left(\rho \frac{\partial V}{\partial \rho} \right) = 0 \quad (5.43)$$

Integrating both sides with respect to ρ , we obtain:

$$\rho \frac{\partial}{\partial \rho} V(\rho) = C_1 , \quad (5.44)$$

where C is an arbitrary constant. Now dividing through by ρ and integrating with respect to ρ again, we obtain:

$$V(\rho) = C_1 \ln \rho + C_2 , \quad (5.45)$$

where C_1 and C_2 are constants that can be determined by boundary conditions. Applying the boundary conditions, we obtain:

$$V(\rho = 0.001 \text{ m}) = C_1 \ln(0.001 \text{ m}) + C_2 = 50 \text{ mV} , \text{ and} \quad (5.46)$$

$$V(\rho = 0.002 \text{ m}) = C_1 \ln(0.002 \text{ m}) + C_2 = 20 \text{ mV} . \quad (5.47)$$

A simple way to solve for C_1 and C_2 here is simply to subtract the second equation from the first equation, which eliminates C_2 ; then solve for C_1 and use that result to solve for C_2 . One finds $C_1 = -43.3 \text{ mV}$ and $C_2 = -249.0 \text{ mV}$. Thus:

$$\boxed{V(\rho) = -(43.3 \text{ mV}) \ln \left(\frac{\rho}{1 \text{ m}} \right) - 249.0 \text{ mV}} , \quad 1 \text{ mm} \leq \rho \leq 2 \text{ mm}. \quad (5.48)$$

Note that an answer that does not include "1 m" in the denominator of the argument of the "ln" function is dangerously ambiguous unless you also specify that ρ must be in meters. Here is another correct solution, this time with the argument in units of millimeters:

$$V(\rho) = -(43.3 \text{ mV}) \ln \left(\frac{\rho}{1 \text{ mm}} \right) + 50.0 \text{ mV} , \quad 1 \text{ mm} \leq \rho \leq 2 \text{ mm}. \quad (5.49)$$

Note that C_2 depends on the units of ρ in the argument of the logarithm function.

[m0021] [1]

5.18-1

A good way to get the charge density is to first find the electric field, and then to apply the boundary condition that relates electric field to surface charge density on a conducting surface. The electric field intensity is, in general:

$$\mathbf{E} = -\nabla V = -\hat{\rho} \frac{\partial V}{\partial \rho} - \hat{\phi} \frac{1}{\rho} \frac{\partial V}{\partial \phi} - \hat{z} \frac{\partial V}{\partial z} . \quad (5.50)$$

The last two terms are zero because the the answer cannot vary with respect to ϕ or z . So we have:

$$\mathbf{E} = -\hat{\rho} \frac{\partial V}{\partial \rho} = -\hat{\rho} \frac{\partial}{\partial \rho} \left[-(43.3 \text{ mV}) \ln \left(\frac{\rho}{1 \text{ m}} \right) - 249.0 \text{ mV} \right] = \hat{\rho} \frac{43.3 \text{ mV}}{\rho} . \quad (5.51)$$

The relevant boundary condition on the inner conductor is that the normal component of the electric flux density \mathbf{D} equals the surface charge density. The normal to the inner conductor is $+\hat{\rho}$, so we have:

$$\rho_s = (+\hat{\rho}) \cdot \mathbf{D}|_{\rho=1 \text{ mm}} = \hat{\rho} \cdot \epsilon \mathbf{E}|_{\rho=1 \text{ mm}} = \epsilon_r \epsilon_0 (43.3 \text{ V/m}) . \quad (5.52)$$

Since $\epsilon_0 = 8.854 \times 10^{-12} \text{ F/m}$ and $\epsilon_r = 2.1$, we have that the surface charge density on the inner conductor is $\boxed{+804 \text{ pC/m}^2}$.

5.18-2

(a) Summarizing the problem statement, we have a sphere of radius $a = 2$ m containing uniformly-distributed charge with volume density $\rho_v = 3$ pC/m³, and the media is a dielectric with $\epsilon_r = 4.5$ everywhere. Poisson's Equation is

$$\nabla^2 V = -\frac{\rho_v}{\epsilon} \quad (5.53)$$

Note that you could also do this problem by integrating over the charge distribution, and that's a great check. However, the problem statement requires you to use Poisson's Equation. The symmetry of the problem suggests the use of spherical coordinates. Noting that $\partial V/\partial\theta$ and $\partial V/\partial\phi$ should be zero due to symmetry, we find

$$\frac{1}{r^2} \frac{\partial}{\partial r} \left(r^2 \frac{\partial V}{\partial r} \right) = -\frac{\rho_v}{\epsilon} \quad (5.54)$$

It's straightforward to solve for V in this case. Here we go:

$$\frac{\partial}{\partial r} \left(r^2 \frac{\partial V}{\partial r} \right) = -\frac{\rho_v}{\epsilon} r^2 \quad (5.55)$$

$$r^2 \frac{\partial V}{\partial r} = -\frac{\rho_v}{3\epsilon} r^3 + C_1 \quad (5.56)$$

where C_1 is an arbitrary constant. Continuing:

$$\frac{\partial V}{\partial r} = -\frac{\rho_v}{3\epsilon} r + \frac{C_1}{r^2} \quad (5.57)$$

$$V(r) = -\frac{\rho_v}{6\epsilon} r^2 + \frac{C_2}{r} + C_3 \quad (5.58)$$

where C_2 and C_3 are arbitrary constants. At this point you should confirm this result by making sure it's a solution to the original equation, and also by checking units.

Outside the sphere, $\rho_v = 0$. Thus:

$$V(r) = \frac{B_o}{r} + A_o \quad r > a \quad (5.59)$$

Here we have replaced the constants C_2 and C_3 with B_o and A_o respectively. This is to remind us that the constants may be different should we consider the region inside the sphere (as we shall soon do). We can determine the value of the constant A_o by noting that $V(r) \rightarrow 0$ as $r \rightarrow \infty$, since the total charge is finite and contained within a finite region. Therefore, A_o must be zero, leading to

$$V(r) = \frac{B_o}{r} \quad r > a \quad (5.60)$$

To determine the value of the constant B_o we're going to have to make some kind of connection with $V(r)$ inside the sphere. Inside the sphere:

$$V(r) = -\frac{\rho_v}{6\epsilon} r^2 + \frac{B_i}{r} + A_i \quad r \leq a \quad (5.61)$$

Here we have replaced the constants C_2 and C_3 with B_i and A_i respectively. We can determine the value of the constant B_i by noting that $V(r)$ must be finite as $r \rightarrow 0$, since the charge density is finite at $r = 0$. Therefore, B_i must be zero, leading to

$$V(r) = -\frac{\rho_v}{6\epsilon}r^2 + A_i \quad r \leq a \quad (5.62)$$

Now we apply the boundary condition at the surface of the sphere. Note that there is no requirement for potential to be continuous (and it wouldn't do us any good even if there were, since we'd be stuck with one equation and two unknowns). The relevant boundary condition at $r = a$ is that the normal component of the electric field should be continuous: Specifically,

$$[\mathbf{D}_o(r = a) - \mathbf{D}_i(r = a)] \cdot \hat{\mathbf{r}} = \rho_s \quad (5.63)$$

where \mathbf{D}_o and \mathbf{D}_i are the electric flux densities outside and inside the sphere respectively, and ρ_s is the surface charge density. The surface charge density ρ_s is zero, since all the charge is taken into account as the volume charge density ρ_v . Also, $\mathbf{D} = \epsilon\mathbf{E}$; therefore, we have

$$[\mathbf{E}_o(r = a) - \mathbf{E}_i(r = a)] \cdot \hat{\mathbf{r}} = 0 \quad (5.64)$$

Next we note \mathbf{E} everywhere should be oriented in the $\hat{\mathbf{r}}$ direction due to symmetry. Thus, we find:

$$E_o(r = a) = E_i(r = a) \quad (5.65)$$

We can find the electric flux density by taking the gradient of the potential:

$$\mathbf{E} = -\nabla V = -\hat{\mathbf{r}} \frac{\partial}{\partial r} \left[-\frac{\rho_v}{6\epsilon}r^2 + A_i \right] = \hat{\mathbf{r}} \frac{\rho_v}{3\epsilon}r \quad r \leq a \quad (5.66)$$

$$\mathbf{E} = -\nabla V = -\hat{\mathbf{r}} \frac{\partial}{\partial r} \left[\frac{B_o}{r} \right] = \hat{\mathbf{r}} \frac{B_o}{r^2} \quad r > a \quad (5.67)$$

Now applying the boundary condition (Equation 5.65):

$$\frac{\rho_v}{3\epsilon}a = \frac{B_o}{a^2} \quad (5.68)$$

Solving for B_o and substituting the result back into Equation 5.60, we obtain:

$$V(r) = \frac{\rho_v a^3}{3\epsilon r} = \frac{\rho_v a^3}{3\epsilon_r \epsilon_0 r} \quad r > a \quad (5.69)$$

(Good time for a units check!) Finally, the answer:

$$V(r) = \frac{0.201 \text{ V}\cdot\text{m}}{r} \quad r > a \quad (5.70)$$

(b) From the previous equation, $V(3 \text{ m}) = 66.9 \text{ mV}$.

[m0021] [3]

5.18-3

A good way to get the charge density is to first find the electric field, and then to apply the boundary condition that relates electric field to surface charge density on a conducting surface. The electric field intensity is:

$$\mathbf{E} = -\nabla V = -\hat{\mathbf{r}} \frac{\partial V}{\partial r} - \hat{\theta} \frac{1}{r} \frac{\partial V}{\partial \theta} - \hat{\phi} \frac{1}{r \sin \theta} \frac{\partial V}{\partial \phi} . \quad (5.71)$$

The last two terms are zero because the the answer cannot vary with respect to θ or ϕ . So we have:

$$\mathbf{E} = -\hat{\mathbf{r}} \frac{\partial V}{\partial r} = -\hat{\mathbf{r}} \frac{\partial}{\partial r} \left[\frac{120 \text{ V} \cdot \text{m}}{r} - 20 \text{ V} \right] = +\hat{\mathbf{r}} \frac{120 \text{ V} \cdot \text{m}}{r^2} . \quad (5.72)$$

The relevant boundary condition on the inner conductor is that the normal component of the electric flux density \mathbf{D} equals the surface charge density. The normal to the inner conductor is $+\hat{\mathbf{r}}$, so we have:

$$\rho_s = (+\hat{\mathbf{r}}) \cdot \mathbf{D}|_{r=1 \text{ m}} = \hat{\mathbf{r}} \cdot \epsilon_0 \mathbf{E}|_{r=1 \text{ m}} = \epsilon_0 (120 \text{ V/m}) . \quad (5.73)$$

Since $\epsilon_0 = 8.854 \times 10^{-12} \text{ F/m}$ in free space, we have that the surface charge density on the inner conductor is $\boxed{1.06 \text{ nC/m}^2}$.

[m0112] [1]

5.22-1

The net charge in the capacitor is zero because the charges on the two plates is equal and opposite. The charge on the positively-charged plate is

$$Q_+ = CV = (20 \text{ pF}) (3 \text{ V}) = \boxed{+60 \text{ pC}}$$

5.23-1

(a) The equivalent circuit is just a resistor R in parallel with a capacitor to which we'll assign the variable C_x . The impedance of the capacitor is $-j/\omega C_x$. Thus, the magnitude of the capacitor's impedance decreases with increasing frequency. The total impedance is the parallel combination of $R = 200 \Omega$ and C_x . The effective resistance will decrease with increasing frequency.

(b) This structure looks a lot like a parallel plate capacitor. Neglecting fringing fields, capacitance is estimated as

$$C_x = \frac{\epsilon HW}{L} = \frac{\epsilon_0 \epsilon_r HW}{L} = \frac{(8.854 \times 10^{-12} \text{ F/m}) \cdot 37 \cdot (0.3 \text{ mm}) (0.3 \text{ mm})}{0.6 \text{ mm}} = \boxed{49.1 \text{ fF}}$$

(c) The impedance is $R \parallel (-j/\omega C_x)$. At $f = 10 \text{ GHz}$, we have $144.8 - j89.4 \Omega$, so the effective resistance is 144.8Ω .

[m0070] [2]

5.23-2

From the problem statement: $C < 3$ pF, $d = 2$ mm, and $\epsilon_r = 3.0$. Note:

$$C \approx \frac{\epsilon A}{d} = \frac{\epsilon_r \epsilon_0 A}{d}$$

where A is the area in common. So:

$$A < \frac{(3 \text{ pF}) d}{\epsilon_r \epsilon_0}$$

Therefore, the common area must be $< 2.26 \times 10^{-4} \text{ m}^2$.

[m0113] [1]

5.24-1

From the problem statement, $C' = 30 \text{ pF/m}$ and $\epsilon_r = 2.25$ for polyethylene. The capacitance of the original coaxial cable is

$$C' = \frac{2\pi\epsilon_s}{\ln(b/a)}$$

where $\epsilon_s = \epsilon_r\epsilon_0$ for the spacer material and b/a is the ratio of the radius of the outer conductor to that of the inner conductor. The capacitance of a coaxial cable that is identical except polyethylene is replaced with air ($\epsilon_s = \epsilon_0$) is:

$$C'_{new} = \frac{2\pi\epsilon_0}{\ln(b/a)}$$

Comparing the two equations, we observe:

$$C'_{new} = \frac{C'}{\epsilon_r} \cong \boxed{13.3 \text{ pF/m}}$$

[m0113] [2]

5.24-2

From the problem statement, $a = 1$ mm, $b = 3$ mm, $\epsilon_s = \epsilon_0$, and $V = +1.5$ kV measured at the outer conductor relative to the inner conductor. The capacitance of this cable is

$$C' = \frac{2\pi\epsilon_0}{\ln(b/a)} \cong 50.6 \text{ pF/m}$$

The outer conductor is positively-charged, and the line charge density on this conductor is

$$\rho_l = C'V \cong \boxed{+76.0 \text{ nC/m}}$$

The circumference of the outer conductor is $2\pi b$, so the surface charge density is

$$\rho_s = \frac{\rho_l}{2\pi b} = \boxed{+4.03 \text{ } \mu\text{C/m}^2}$$

[m0114] [1]

5.25-1

From the problem statement, $C = 4.7 \text{ mF}$ and $V = 16 \text{ V}$. The energy stored is

$$W_e = \frac{1}{2}CV^2 \cong \boxed{602 \text{ mJ}}$$

[m0114] [2]

5.25-2

From the problem statement, $C = 3.5$ pF, $d = 0.1$ mm, $\epsilon_r = 10$, and $V = 3$ V. For an ideal parallel plate capacitor,

$$C = \frac{\epsilon A}{d}$$

where $\epsilon = \epsilon_r \epsilon_0$ is the spacer permittivity and A is the plate area. In the present problem, we find:

$$A = \frac{Cd}{\epsilon_0 \epsilon_r} \cong 3.95 \times 10^{-6} \text{ m}^2$$

The volume of the capacitor is

$$Ad \cong 3.95 \times 10^{-10} \text{ m}^3$$

The energy in the capacitor is

$$W_e = \frac{1}{2} CV^2 = 15.75 \text{ pJ}$$

Therefore, the energy density is

$$\frac{W_e}{Ad} \cong \boxed{39.8 \text{ mJ/m}^3}$$

Chapter 6

Steady Current and Conductivity

[m0071] [1]

6.4-1

(a) Resistance R_{steel} per unit length l of the steel-only wire:

$$R'_{steel} = \frac{R_{steel}}{l} = \frac{1}{\sigma_{steel} \cdot \pi a^2} = \frac{1}{(1.00 \times 10^6 \text{ S/m}) \cdot \pi (0.1 \text{ mm})^2} = \boxed{31.8 \text{ } \Omega/\text{m}}$$

(b) Resistance per unit length of gold clad having outer radius b :

$$R'_{gold} = \frac{1}{\sigma_{gold} \cdot \pi (b^2 - a^2)}$$

The total resistance per unit length $R'_{total} = 10 \text{ } \Omega/\text{m}$ is the parallel combination:

$$\frac{1}{R'_{total}} = \frac{1}{R'_{steel}} + \frac{1}{R'_{gold}} = \frac{1}{R'_{steel}} + \sigma_{gold} \cdot \pi (b^2 - a^2)$$

Solving for b :

$$b = \sqrt{\left[\frac{1}{R'_{total}} - \frac{1}{R'_{steel}} + \sigma_{gold} \cdot \pi a^2 \right] \frac{1}{\sigma_{gold} \cdot \pi}} = 0.10263 \text{ mm}$$

So the required thickness of gold is $b - a$, which is $\boxed{2.63 \text{ } \mu\text{m}}$.

6.4-2

In the transmission line equivalent circuit (R', G', C', L') model, R' is a series resistance. Also, any current applied to either conductor must return on the other conductor. Therefore, we have

$$R' = R'_{ic} + R'_{oc} \quad (6.1)$$

where R'_{ic} is the resistance per length of the inner conductor and R'_{oc} is the resistance per length of the outer conductor. Note

$$R'_{ic} = \frac{1}{\sigma_{ic} A_{ic}} \quad (6.2)$$

where σ_{ic} is the inner conductor conductivity and A_{ic} is the cross-sectional area of the inner conductor. Thus, $R'_{ic} = 0.164 \Omega/\text{m}$. Also

$$R'_{oc} = \frac{1}{\sigma_{oc} A_{oc}} \quad (6.3)$$

where $\sigma_{oc} = \sigma_{ic}$ (from the problem statement) and A_{oc} is the cross-sectional area of the outer conductor, through which the current flows. Note:

$$A_{oc} = \pi b_2^2 - \pi b_1^2 \quad (6.4)$$

where b_1 and b_2 are the radii of the inner and outer surfaces, respectively, of the outer conductor. From the problem statement we have

$$b_1 = \left(1 - \frac{0.05}{2}\right) b \cong 0.1809 \text{ cm} \quad (6.5)$$

$$b_2 = \left(1 + \frac{0.05}{2}\right) b \cong 0.1901 \text{ cm} \quad (6.6)$$

(Check: the mean of b_1 and b_2 is $(b_1 + b_2)/2 = b$, as expected.) So $A_{oc} \cong 1.081 \times 10^{-6} \text{ m}^2$, and subsequently, $R'_{oc} \cong 0.0406 \Omega/\text{m}$. Finally, we obtain $R' = R'_{ic} + R'_{oc} \cong 0.205 \Omega/\text{m}$.

[m0071] [3]

6.4-3

If the voltage drop is to be reduced by a factor of 2, then the resistance must be decreased by a factor of 2. The DC resistance of a wire is $l/\sigma A$ where l is length, σ is conductivity, and A is cross-sectional area. The use of the term “diameter” implies the wire has circular cross section, so the original wire has $A = \pi (D_0/2)^2$ and

$$R = \frac{l}{\sigma \pi (D_0/2)^2}$$

For this to be reduced by a factor of two, the new diameter must be $\boxed{\sqrt{2} \cdot D_0}$.

[m0071] [4]

6.4-4

The DC resistance of such a resistor is $R = l/\sigma A$ where A is cross-sectional area. In this case, we may write

$$R = \frac{l}{\sigma A} = \frac{l}{\sigma \pi (D/2)^2} = \frac{4l}{\sigma \pi D^2}$$

where D is diameter. Note that D should increase by a factor of $\sqrt{2}$ in order to reduce R by a factor of two. Thus, D becomes $\cong 1.41$ mm.

[m0105] [1]

6.5-1

The conductance per unit length is

$$G' = \frac{2\pi\sigma_s}{\ln(b/a)}$$

where σ_s is the spacer conductivity, and a and b are the radii of the inner and outer conductors, respectively. From the book, RG-59 has $\sigma_s \cong 5.9 \times 10^{-5}$ S/m and exhibits $G' \cong 200 \mu\text{S/m}$ normally. From the appendix “Conductivity of Some Common Materials,” $\sigma_s \approx 5$ S/m. The worst case is that spacer assumes the much higher conductivity of seawater, in which case:

$$G' \rightarrow (200 \mu\text{S/m}) \frac{5 \text{ S/m}}{5.9 \times 10^{-5} \text{ S/m}} \cong \boxed{17.0 \text{ S/m}}$$

[m0106] [1]

6.6-1

From the problem statement:

Length $l = 1.2$ cm,

radius $a = 1.6$ mm,

\mathbf{J} is uniform (constant) in the resistor,

$\mathbf{E} = \hat{\mathbf{z}}E_0/\sqrt{\rho}$ where $E_0 \triangleq 3 \text{ V} \cdot \text{m}^{-1/2}$, and

$P = 5 \text{ W}$.

Let σ be the conductivity of the material comprising the resistor. Then

$$P = \int_{\mathcal{V}} \sigma |\mathbf{E}|^2 dv$$

where \mathcal{V} is the volume representing the resistor.

We cannot assume the material comprising the resistor is homogeneous. So, what *do* we know about σ ? Recall Ohm's Law, $\mathbf{J} = \sigma \mathbf{E}$. Since \mathbf{E} is proportional to $1/\sqrt{\rho}$ and \mathbf{J} is independent of ρ , σ must have the form $\sigma = \sigma_0 \sqrt{\rho}$ where σ_0 is a constant having units of $\text{S} \cdot \text{m}^{-3/2}$.

Continuing,

$$P = \int_{\mathcal{V}} (\sigma_0 \sqrt{\rho}) \left(\frac{E_0}{\sqrt{\rho}} \right)^2 dv = \sigma_0 E_0^2 \int_{\mathcal{V}} \rho^{-1/2} dv$$

Let us assume the ends of the resistor are at $z = 0$ and $z = l$. Then:

$$\begin{aligned} P &= \sigma_0 E_0^2 \int_{\rho=0}^a \int_{\phi=0}^{2\pi} \int_{z=0}^l \rho^{-1/2} [d\rho (\rho d\phi) dz] \\ &= \sigma_0 E_0^2 \left(\int_{\rho=0}^a \rho^{+1/2} d\rho \right) \left(\int_{\phi=0}^{2\pi} d\phi \right) \left(\int_{z=0}^l dz \right) \\ &= \sigma_0 E_0^2 \left(\frac{2}{3} a^{3/2} \right) (2\pi) (l) \end{aligned}$$

Solving for σ_0 :

$$\sigma_0 = \frac{3P}{4\pi a^{3/2} l E_0^2} \cong 173 \text{ kS} \cdot \text{m}^{-3/2}$$

and subsequently,

$$\sigma \cong \boxed{(173 \text{ kS} \cdot \text{m}^{-3/2}) \sqrt{\rho}}$$

Chapter 7

Magnetostatics

[m0115] [1]

7.1-1

Divergence of the electric field:

$$\nabla \cdot \mathbf{D} = \rho_v \text{ , so}$$

$$\boxed{\nabla \cdot \epsilon \mathbf{E} = \rho_v}$$

where ϵ has units of F/m and ρ_v has units of C/m³.

Curl of the electric field:

$$\boxed{\nabla \times \mathbf{E} = 0}$$

Divergence of the magnetic field:

$$\nabla \cdot \mathbf{B} = 0 \text{ , so}$$

$$\boxed{\nabla \cdot \mathbf{H} = 0}$$

Curl of the magnetic field:

$$\nabla \times \mathbf{H} = \mathbf{J}$$

Noting $\mathbf{J} = \sigma \mathbf{E}$:

$$\boxed{\nabla \times \mathbf{H} = \sigma \mathbf{E}}$$

where σ has units of S/m.

[m0047] [1]

7.3-1

The differential form of Gauss' Law for magnetism requires

$$\nabla \cdot \mathbf{B} = 0$$

According to the reported measurement:

$$\nabla \cdot \mathbf{B} = \left(\hat{\mathbf{x}} \frac{\partial}{\partial x} + \hat{\mathbf{y}} \frac{\partial}{\partial y} + \hat{\mathbf{z}} \frac{\partial}{\partial z} \right) \cdot \hat{\mathbf{x}} B_0 x^2 = 2B_0 x$$

Therefore, the measurement is plausible only if B_0 is zero.

[m0119] [1]

7.5-1

The magnetic flux *density* (not the same as magnetic flux!) in this case is given by

$$\mathbf{B}(\rho) = \hat{\phi} \frac{\mu_0 I}{2\pi\rho} . \quad (7.1)$$

The magnetic flux is simply \mathbf{B} integrated over the area of the loop (i.e., flux divided by area, times area, is flux):

$$\Phi = \int_{\mathcal{S}} \mathbf{B} \cdot d\mathbf{s} = \int_{\rho=3 \text{ cm}}^{23 \text{ cm}} \int_{z=0}^{30 \text{ cm}} \hat{\phi} \frac{\mu_0 I}{2\pi\rho} \cdot \hat{\phi} d\rho dz \quad (7.2)$$

Where \mathcal{S} is the area enclosed by the loop, and the absolute values of z don't matter due to symmetry, so you can pick any z 's you want as long as you cover 30 cm in the z direction. Evaluating:

$$\Phi = \frac{\mu_0 I}{2\pi} \left[\int_{\rho=3 \text{ cm}}^{23 \text{ cm}} \frac{d\rho}{\rho} \right] \left[\int_{z=0}^{30 \text{ cm}} dz \right] = \frac{\mu_0 I}{2\pi} \left[\ln \frac{23}{3} \right] (30 \text{ cm}) = 3 \mu\text{T}\cdot\text{m}^2 \quad (7.3)$$

Solving for I we have

$$I = (3 \mu\text{T}\cdot\text{m}^2) \left(\frac{2\pi}{4\pi \times 10^{-7} \text{ H/m}} \right) \left[\ln \frac{23}{3} \right]^{-1} (0.3 \text{ m})^{-1} = 24.5 \frac{\text{T}\cdot\text{m}^2}{\text{H}} \quad (7.4)$$

To get to units of A, the traditional units of current, recall that inductance (H) is defined as magnetic flux ($\text{T}\cdot\text{m}^2$) divided by current (A), so we're already there! Thus, we have $I = \boxed{24.5 \text{ A}}$.

[m0119] [2]

7.5-2

The magnetic flux *density* (not the same as magnetic flux!) is given by

$$\mathbf{B}(\rho) = \hat{\phi} \frac{\mu_0 I}{2\pi\rho} . \quad (7.5)$$

The magnetic flux is simply \mathbf{B} integrated over the area of the loop (i.e., flux divided by area, times area, is flux):

$$\Phi = \int_{\mathcal{S}} \mathbf{B} \cdot d\mathbf{s} = \int_{\rho=0.01 \text{ m}}^{0.02 \text{ m}} \int_{z=0}^{0.10 \text{ m}} \hat{\phi} \frac{\mu_0 I}{2\pi\rho} \cdot \hat{\phi} d\rho dz \quad (7.6)$$

Evaluating:

$$\Phi = \frac{\mu_0 I}{2\pi} \left[\int_{\rho=0.01 \text{ m}}^{0.02 \text{ m}} \frac{d\rho}{\rho} \right] \left[\int_{z=0}^{0.10 \text{ m}} dz \right] \quad (7.7)$$

$$= \frac{(4\pi \times 10^{-7} \text{ H/m})(3 \text{ A})}{2\pi} \left[\ln \frac{0.02}{0.01} \right] (0.10 \text{ m}) = 41.6 \text{ nT}\cdot\text{m}^2 \quad (7.8)$$

Note that this may also be written as 41.6 nWb, since $1 \text{ Wb} = 1 \text{ T}\cdot\text{m}^2$.

[m0119] [3]

7.5-3

Ampere's Law is

$$\int_{\mathcal{C}} \mathbf{H} \cdot d\mathbf{l} = I_{encl} \quad (7.9)$$

where \mathcal{C} is any path which encloses the current. A convenient path is just a constant- z circle with radius a :

$$\int_{\phi=0}^{2\pi} \mathbf{H} \cdot \hat{\phi} a d\phi = I \quad (7.10)$$

Also, $\mathbf{H} = \mathbf{B}/\mu_0$, so

$$\int_{\phi=0}^{2\pi} \hat{\phi} J_0 a \cdot \hat{\phi} a d\phi = I \quad (7.11)$$

Thus:

$$I = 2\pi a^2 J_0 = \boxed{20.0 \text{ mA}} . \quad (7.12)$$

[m0119] [4]

7.5-4

Apply the right hand rule. When the thumb of the right hand points in the $-\hat{\mathbf{y}}$ direction, the curled fingers of the right hand point in the $+\hat{\mathbf{z}}$ direction at $(+1, +1, 0)$ m.

[m0119] [5]

7.5-5

The measurements are explained by a wire aligned along the y -axis, with current flowing in the $-\hat{y}$ direction. This can be confirmed using the right-hand rule – point the thumb of your right hand in the direction of the current, and the curled fingers of your right hand point in the direction of the magnetic field.

[m0120] [1]

7.6-1

From the problem statement, we have that Coil 1 has $N_1 = 100$ and $I_1 = 2$ A. Coil 2 has $N_2 = 300$ and $I_2 = 4$ A, and is wound in the opposite direction. Both coils have $l = 10$ cm and $\mu = \mu_0$. For Coil 1 we have

$$\mathbf{B}_1 = \hat{\mathbf{b}}_1 \mu_0 \frac{N_1 I_1}{l}$$

where $\hat{\mathbf{b}}_1$ points in the direction of \mathbf{B}_1 inside the coil. For Coil 2 we have

$$\mathbf{B}_2 = -\hat{\mathbf{b}}_1 \mu_0 \frac{N_2 I_2}{l}$$

The total field $\mathbf{B} = \mathbf{B}_1 + \mathbf{B}_2$, so:

$$\left| \hat{\mathbf{b}}_1 \cdot (\mathbf{B}_1 + \mathbf{B}_2) \right| = \left| \mu_0 \frac{N_1 I_1}{l} - \mu_0 \frac{N_2 I_2}{l} \right| = \frac{\mu_0}{l} |N_1 I_1 - N_2 I_2| \cong \boxed{12.6 \text{ mT}}$$

[m0049] [1]

7.7-1

The magnetic field in either a straight coil or a toroidal coil is proportional to current. Current is proportional to the conductivity of the wire forming the coil. Therefore, doubling the conductivity will double the magnetic field strength.

[m0123] [1]

7.12-1

The inductance of a linear inductor depends only on geometry and materials; therefore, the inductance remains $\boxed{1 \text{ H}}$.

[m0124] [1]

7.13-1

If the loops are close together, then presumably the magnetic flux Φ through each winding is equal. Thus,

$$L \triangleq \frac{N\Phi}{I}$$

where N is number of linkages, which in this case is the number of windings. Thus,

$$\Phi = \frac{LI}{N} = \boxed{\frac{LI}{2}}$$

[m0124] [2]

7.13-2

From the problem statement:

length $l = 5$ cm,

radius $a = 5/2 = 2.5$ mm,

number of windings $N = 300$, and

relative permeability $\mu_r = 200$.

Since $l \gg a$ and the winding density N/l is large, we may use the “long straight coil” expression

$$L \approx \frac{\mu N^2 A}{l}$$

In the present problem:

$$L \approx \frac{(\mu_r \mu_0) N^2 (\pi a^2)}{l} \cong \boxed{8.88 \text{ mH}}$$

where $\mu_0 = 4\pi \times 10^{-7}$ H/m.

[m0127] [1]

7.15-1

Since

$$W_e = \frac{1}{2}LI^2$$

We have

$$I = \sqrt{\frac{2W_e}{L}} = \sqrt{\frac{2 \cdot 2 \text{ mJ}}{47 \text{ mH}}} \cong \boxed{292 \text{ mA}}$$

[m0127] [2]

7.15-2

The energy initially stored in the inductor is

$$W_m = \frac{1}{2}LI^2 = 6 \text{ nJ}$$

The energy stored in the capacitor after the transfer is

$$W_e = \frac{1}{2}CV^2 = 6 \text{ nJ}$$

so $V = \boxed{1.73 \text{ V}}$.

Chapter 8

Time-Varying Fields

[m0055] [1]

8.3-1

Faraday's Law says that the potential (or "emf") induced in the coil is

$$V_{emf} = -N \frac{d}{dt} \Phi(t)$$

where

$$\Phi(t) = \int_S \mathbf{B} \cdot d\mathbf{s}$$

and where $\mathbf{B}(t)$ is the magnetic flux density and \mathcal{S} is the surface defined by the cross-section of the coil. When the magnetic flux is not varying with time, the potential is zero, so this is the answer to parts (a) and (c).

While the magnetic field is being reduced, a non-zero potential is possible. Since the magnetic field is spatially-uniform and parallel to the axis of the coil, the above integral simplifies to

$$\Phi(t) = B(t) \cdot A$$

where $B(t)$ is the scalar magnetic flux density and A is the cross-sectional area of the coil. We do not know precisely how B varies with time (i.e., linearly with time? exponential decay? etc.), so we cannot take a formal derivative. We can however estimate the derivative:

$$\frac{d}{dt} \Phi(t) \approx \frac{\Delta \Phi}{\Delta t} = \frac{B(t_0 + 200 \text{ ms}) \cdot A - B(t_0) \cdot A}{200 \text{ ms}}$$

where t_0 is the time at which the magnitude of the magnetic field begins to decrease. We also note

$$B(t_0) = \mu_r \mu_0 H(t_0) = (2 \times 10^5) \cdot (4\pi \times 10^{-7} \text{ H/m}) \cdot (20.0 \text{ mA/m}) = 5.03 \text{ mT}$$

and $B(t_0 + 200 \text{ ms}) = 1.01 \text{ mT}$. Since $A = 200 \text{ cm}^2 = 0.020 \text{ m}^2$, we may now calculate

$$|V_{emf}| \approx N \left| \frac{\Delta \Phi}{\Delta t} \right| = \boxed{20.1 \text{ mV}}$$

This is the answer to part (b). In some sense, this is the average emf generated in the coil over the 200 ms period of interest; however, more precisely, this is merely the best estimate of the instantaneous emf generated during that time, given the limited information about the time dependence of the magnetic field over that time.

8.3-2

Faraday's Law says that the emf induced in a this loop is

$$V_{emf} = -\frac{d}{dt}\Phi(t)$$

(since a loop has $N = 1$ turn) where

$$\Phi = \int_S \mathbf{B} \cdot d\mathbf{s}$$

Let us define V_{emf} to be across the resistor, with the “+” terminal on the right side and the “-” terminal on the left side.¹ Then:

$$\Phi = \int_{x=-L/2}^{+L/2} \int_{y=y_0}^{y_0+w} [\hat{\mathbf{z}} B_0 e^{ay}] \cdot [+ \hat{\mathbf{z}} dx dy]$$

where y_0 is the location of the left side of the loop. Then:²

$$\Phi = B_0 \left[\int_{x=-L/2}^{+L/2} dx \right] \left[\int_{y=y_0}^{y_0+w} e^{ay} dy \right] = \frac{B_0 L}{a} e^{ay_0} [e^{aw} - 1]$$

Next we're going to want to take the time derivative of Φ . However, to do that properly we need to make sure we identify everything in the above expression for Φ that has a time dependence. Only y_0 depends on time. To make this clear, let us write $y_0 = ut + b$, which places the left side of the loop at $y = b$ at time $t = 0$. Now we may write:

$$\Phi(t) = \frac{B_0 L}{a} e^{aut} e^{ab} [e^{aw} - 1]$$

so:³

$$V_{emf}(t) = -\frac{d}{dt}\Phi(t) = B_0 L u e^{aut} e^{ab} [1 - e^{aw}]$$

The problem statement asks us to assess the situation when the left side of the loop is at $y = 0.5$ m, so we choose $t = 0$ and $b = 0.5$ m (since we said earlier $y_0 = ut + b$). Also from the problem statement, $u = -250$ m/s. Thus:

$$V_{emf}(t = 0) = -\frac{d}{dt}\Phi(t = 0) = B_0 L u e^{ab} [1 - e^{aw}] = -7.60 \text{ A}$$

Finally, the current is simply this divided by R , which is -3.04 A. Because we chose the “+” terminal to be on the right, the *reference* direction for current must be counter-clockwise (i.e., this is the necessary direction for positive current to dissipate positive power in the

¹Not the only way to do it! This choice is arbitrary. Choosing the opposite reference polarity should give you the exact same answer as long as you follow through correctly.

²Once you complete this integration, it's a good time for a units check!

³Once you complete this differentiation, it's a good time for a units check!

resistor, or alternatively you may think of this as being the necessary reference direction for the loop to behave as a power source). We have found that the current is negative with respect to this reference direction; therefore, the induced current is 3.04 A, clockwise.

You can check to make sure you got the correct current direction by using Lenz's Law. If the current is flowing clockwise, then the induced magnetic field in the loop is in the $-\hat{z}$ direction. The impressed magnetic flux is increasing, since the loop area is constant and the magnetic field in the loop increases in the $+\hat{z}$ direction as the loop slides to the left. Therefore, the induced current is acting to oppose the change in the impressed magnetic flux, as is required by Lenz's Law.

8.3-3

(a) Let's stick with the SI system of units. Since "1" in the expression for \mathbf{B} appears to be unitless, B_0 must have units of $\boxed{\text{T (or Wb/m}^2\text{, if you prefer)}}$. Since t is in s and "1" appears to be unitless, k must have units of $\boxed{1/\text{s}}$. Since a has units of m and equals vt , v must have units of $\boxed{\text{m/s}}$.

(b) Here's Faraday's Law:

$$V_g(t) = -N \frac{d}{dt} \Phi \quad (8.1)$$

where $N = 1$ since it is a loop (not a coil), and the magnetic flux is

$$\Phi = \int_S \mathbf{B} \cdot d\mathbf{s} = \int_S [\hat{\mathbf{z}} B_0 (1 + kt)] \cdot [-\hat{\mathbf{z}} ds] = -B_0 (1 + kt) \int_S ds \quad (8.2)$$

Note that $d\mathbf{s}$ is in the $-\hat{\mathbf{z}}$ direction. This is from the right-hand rule (of calculus), in which your thumb is along the loop (not the gap) pointing along the direction from the "−" terminal to the "+" terminal. Since S represents the surface defined by the loop (actually *any* surface defined by the loop, but we'll keep it simple...), we have

$$\Phi = -B_0 (1 + kt) (\pi a^2) \quad (8.3)$$

Substituting $a = vt$ and expanding into two terms we get

$$\Phi = -B_0 \pi v^2 t^2 - B_0 k \pi v^2 t^3 \quad (8.4)$$

So Faraday's Law says:

$$V_g(t) = 2B_0 \pi v^2 t + 3B_0 k \pi v^2 t^2 \quad (8.5)$$

which is more compactly written as:

$$\boxed{V_g(t) = B_0 \pi v^2 (2t + 3kt^2)} \quad (8.6)$$

Good time for a units check: Can you confirm that the result is dimensionally correct?

(c) The first problem is to determine the motional and transformer emf, so we should be clear on what we mean by these terms. *Motional emf* is the contribution to the total emf which is associated with changes in the size, shape, or orientation of the surface through which the magnetic field lines are linked. *Transformer emf* is the contribution to the total emf which is associated with changes in the magnetic field.

With that in mind, let's consider an *incorrect* solution: You can't set $v = 0$ and call the result (in this case, zero) the transformer emf. This is wrong because if v were equal to zero for some radius $a > 0$, then the calculated emf would be potentially non-zero because the magnetic field is still time-varying.

However, it *is* true that setting $k = 0$ yields the motional emf (you can verify this for yourself after reading through this solution), although this is pretty hard to justify, especially

since we just saw that arbitrarily setting constants to zero is dangerous. So, if you go that approach you must be able to explain why this is reasonable.

With all this in mind, here are three reasonable ways to get a solution:

1. You could calculate the motional emf and transformer emf using Faraday's Law, but in two separate steps; that is, work out the emf for a static loop (to get the transformer emf) and then for a static field (to get the motional emf).
2. You could calculate motional emf from magnetostatics (i.e., assume a static magnetic field), then subtract this result from your answer for part (b) to get the transformer emf.
3. The approach followed below, which is probably best since it deals directly with the concepts of time-varying loop size vs. time-varying magnetic field.

Here we go:

$$V_g(t) = -\frac{d}{dt}\Phi = -\frac{d}{dt}\int_S \mathbf{B} \cdot d\mathbf{s} = -\frac{d}{dt}\int_S [\hat{\mathbf{z}}B(t)] \cdot [-\hat{\mathbf{z}}ds] \quad (8.7)$$

where $B(t) \equiv B_0(1 + kt)$; i.e., the scalar component of the magnetic field. Continuing:

$$V_g(t) = +\frac{d}{dt}\left[B(t)\int_S ds\right] = +\frac{d}{dt}[B(t)A(t)] \quad (8.8)$$

where $A(t) \equiv \pi a^2(t)$; i.e., the area of the loop. The value in setting the problem up this way is that we now have the magnetic field and the loop area set up as distinct, identifiable factors in the solution. Now we differentiate using the chain rule:

$$V_g(t) = \left[\frac{d}{dt}B(t)\right]A(t) + B(t)\left[\frac{d}{dt}A(t)\right] \quad (8.9)$$

Now we see clearly that the first term is the transformer emf and the second term is the motional emf. Let's label these $V_g^{tr}(t)$ and V_g^m respectively. Now:

$$V_g^{tr}(t) = \left[\frac{d}{dt}B(t)\right]A(t) = B_0k \cdot \pi a^2 \quad (8.10)$$

$$V_g^m(t) = B(t)\left[\frac{d}{dt}A(t)\right] = B(t) \cdot 2\pi a \cdot v \quad (8.11)$$

Note that *now* we get the "expected" result when we set $k = 0$ and then $v = 0$. Also note that transformer emf depends on loop *area*, and motional emf depends on loop *perimeter* – you might have suspected this based on other problems you have encountered.

OK, now we're ready to wrap up. To find out when the contributions of the transformer emf and motional emf are equal, we set the above expressions equal and solve for time $t = t_{eq}$. Here we go:

$$B_0k \cdot \pi a^2 = B(t_{eq}) \cdot 2\pi a \cdot v \quad (8.12)$$

Noting that $a = vt$ and $B(t) = B_0(1 + kt)$:

$$B_0k \cdot \pi v^2 t_{eq}^2 = B_0(1 + kt_{eq}) \cdot 2\pi v^2 t_{eq} \quad (8.13)$$

Solving the above expression we find that $t_{eq} = -2/k$ (good time for a units check, by the way). Negative times don't really make sense in the problem (how can the loop have zero radius and before that negative radius?), so the transformer emf and motional emf are never equal for $k > 0$ (i.e., magnetic field magnitude increasing). However, $t_{eq} = +2/|k|$ when $k < 0$. So, the answer to the problem is:

at $t = -2/k$, and only if the magnitude of the magnetic field is *decreasing*.

[m0056] [1]

8.4-1

The measured voltage is the “transformer emf” induced by the magnetic flux through the loop. According to Faraday’s Law, we have in general that:

$$V_{\text{emf}} = -N \frac{d}{dt} \Phi = -N \frac{d}{dt} \int_{\mathcal{S}} \mathbf{B} \cdot d\mathbf{s}$$

Here, the number of turns, N , is 1; $d\mathbf{s}$ is perpendicular to the loop in the direction determined by the Stoke’s Law convention (i.e., according to the reference polarity chosen for V_{emf}), and \mathbf{B} can be written as

$$\mathbf{B} = \hat{\mathbf{b}}B(t) = \hat{\mathbf{b}}B_0 \sin(2\pi ft + \alpha)$$

where $\hat{\mathbf{b}}$ is simply a unit vector indicating the direction of \mathbf{B} . We know $\hat{\mathbf{b}}$ is a constant with respect to position because \mathbf{B} was specified to be a *uniform* magnetic field. Thus, we have for any particular orientation of the loop ds :

$$V_{\text{emf}} = -B_0 \left[\frac{d}{dt} \sin(2\pi ft + \alpha) \right] \left[\hat{\mathbf{b}} \cdot \int_{\mathcal{S}} d\mathbf{s} \right] .$$

$|V_{\text{emf}}|$ is maximized when $\hat{\mathbf{b}}$ and $d\mathbf{s}$ point either in the same direction, or in exactly opposite directions. In this case, the magnitude of the quantity in the rightmost square brackets is simply the area of the loop, A , which here is 0.0314 m^2 according to the problem statement. For this orientation, we have:

$$|V_{\text{emf}}| = B_0 [2\pi f \cos(2\pi ft + \alpha)] A .$$

The above quantity is maximized when $\cos(2\pi ft + \alpha) = 1$, which corresponds to the *peak* magnitude of V_{emf} , which is one-half of the peak-to-peak magnitude. Thus:

$$B_0 2\pi f A = 0.5 \times 20 \text{ mV}_{pp} , \text{ thus:}$$

$$B_0 = \frac{0.5 \times 0.02 \text{ V}_{pp}}{2\pi(100 \times 10^3 \text{ Hz})(0.0314 \text{ m}^2)} = \boxed{507 \text{ nT}} .$$

[m0031] [1]

8.5-1

In the original scenario:

$$\frac{V_2}{V_1} = p \frac{N_2}{N_1}$$

where $p = \pm 1$ depending on the relative orientation of the windings ($p = -1$ for the example shown in the book). Let V'_2 be the new potential on the secondary coil. From Faraday's Law:

$$V'_2 = N_2 \frac{\partial}{\partial t} \Phi'_2$$

where Φ'_2 is the magnetic flux through the secondary coil after the modification. Note

$$\Phi'_2 = \frac{\Phi_2}{2}$$

since the secondary coil now intersects only half the flux it did previously. Subsequently,

$$\Phi'_2 = p \frac{\Phi_1}{2}$$

Now:

$$V'_2 = p \frac{1}{2} N_2 \frac{\partial}{\partial t} \Phi_1 = p \frac{1}{2} \frac{N_2}{N_1} \left(N_1 \frac{\partial}{\partial t} \Phi_1 \right) = p \frac{1}{2} \frac{N_2}{N_1} V_1$$

From the problem statement, $N_1 = 200$ and $N_2 = 300$. Also $p = -1$ for the example shown in the book. Therefore,

$$V'_2 = \boxed{-\frac{3}{4} V_1}$$

with the sign depending on the relative orientations of the coil windings.

[m0031] [2]

8.5-2

The transformer is an application of Faraday's law, which is intrinsic to the Maxwell-Faraday Equation:

$$\nabla \times \mathbf{E} = -\frac{\partial}{\partial t} \mathbf{B}$$

[m0030] [1]

8.7-1

From the problem statement:

$$B_0 = 2 \text{ T},$$

$$A = \pi (2 \text{ m}^2) = 4\pi \text{ m}^2,$$

the peak value of V_T is 5 V, and

$V_T(t = 0) = 0$ and increasing.

Since the loop is rotating in a static uniform magnetic field, V_T must be sinusoidally-varying. A general form for this variation is

$$V_T(t) = AB_0\omega \cos(\omega t + \psi)$$

where $\omega = 2\pi f$ is the angular frequency of rotation and ψ is an as-yet unknown phase offset. However, it is known that

$$V_T(t = 0) = AB_0\omega \cos(\psi) = 0$$

so ψ must be either $\pi/2$ or $3\pi/2$. Since V_T is increasing at $t = 0$, ψ must be $3\pi/2$.

Furthermore, we know the peak value of V_T . In the context of the general form, we find:

$$V_T = AB_0\omega = 5 \text{ V} \quad \text{at maximum}$$

and therefore, $\omega \cong 0.199 \text{ rad/s}$.

Putting this all together:

$$V_T(t) \cong \boxed{(5 \text{ V}) \cos \left([0.199 \text{ rad/s}] t + \frac{3\pi}{2} \right)}$$

[m0053] [1]

8.9-1

From the problem statement, the electric field intensity is

$$\mathbf{E} = \hat{\mathbf{y}} (3 \text{ V m}^{-1} \text{ s}^{-2}) t^2$$

(The fact that this is electric *field intensity* can be confirmed using dimensional analysis.)

The displacement current density in free space is

$$\frac{\partial \mathbf{D}}{\partial t} = \epsilon_0 \frac{\partial \mathbf{E}}{\partial t} = \hat{\mathbf{y}} \epsilon_0 (6 \text{ V m}^{-1} \text{ s}^{-2}) t \cong \hat{\mathbf{y}} (53.1 \text{ pC m}^{-2} \text{ s}^{-2}) t = \boxed{\hat{\mathbf{y}} \left(53.1 \frac{\text{pA}}{\text{m}^2 \text{ s}} \right) t}$$

Chapter 9

Plane Wave Propagation in Lossless Media

[m0042] [1]

9.1-1

The general, time-domain, differential form of Ampere's Law is:

$$\nabla \times \mathbf{H} = \mathbf{J} + \frac{\partial \mathbf{D}}{\partial t}$$

The relationship between these quantities and the phasor representation of the same quantities is:

$$\begin{aligned}\mathbf{H} &= \text{Re} \left\{ \tilde{\mathbf{H}} e^{j\omega t} \right\} , \\ \mathbf{J} &= \text{Re} \left\{ \tilde{\mathbf{J}} e^{j\omega t} \right\} , \text{ and} \\ \mathbf{D} &= \text{Re} \left\{ \tilde{\mathbf{D}} e^{j\omega t} \right\} ;\end{aligned}$$

Now substituting these quantities into Ampere's Law we have:

$$\nabla \times \left[\text{Re} \left\{ \tilde{\mathbf{H}} e^{j\omega t} \right\} \right] = \text{Re} \left\{ \tilde{\mathbf{J}} e^{j\omega t} \right\} + \frac{\partial}{\partial t} \left[\text{Re} \left\{ \tilde{\mathbf{D}} e^{j\omega t} \right\} \right]$$

The order of the “*Re*” operator and any linear real-valued operator can be exchanged (see the textbook section on phasors for a proof of this). Taking advantage of this in the first and last terms, we obtain:

$$\text{Re} \left\{ \nabla \times \left[\tilde{\mathbf{H}} e^{j\omega t} \right] \right\} = \text{Re} \left\{ \tilde{\mathbf{J}} e^{j\omega t} \right\} + \text{Re} \left\{ \frac{\partial}{\partial t} \left[\tilde{\mathbf{D}} e^{j\omega t} \right] \right\}$$

Note that the curl (“ $\nabla \times$ ”) operator operates only on position, and not on time. Thus, we may rewrite the first term as shown below:

$$\text{Re} \left\{ \left[\nabla \times \tilde{\mathbf{H}} \right] e^{j\omega t} \right\} = \text{Re} \left\{ \tilde{\mathbf{J}} e^{j\omega t} \right\} + \text{Re} \left\{ \frac{\partial}{\partial t} \left[\tilde{\mathbf{D}} e^{j\omega t} \right] \right\}$$

Note also that partial derivative in the last term operates only on time, whereas $\tilde{\mathbf{D}}$, being a phasor, is independent of time. Therefore, the partial derivative operates only on the factor $e^{j\omega t}$, and we have:

$$\text{Re} \left\{ \left[\nabla \times \tilde{\mathbf{H}} \right] e^{j\omega t} \right\} = \text{Re} \left\{ \tilde{\mathbf{J}} e^{j\omega t} \right\} + \text{Re} \left\{ \tilde{\mathbf{D}} \cdot j\omega e^{j\omega t} \right\} .$$

Comparing terms above, we find that the phasor expression of Ampere's Law that we seek is:

$$\nabla \times \tilde{\mathbf{H}} = \tilde{\mathbf{J}} + j\omega \tilde{\mathbf{D}} .$$

[m0042] [2]

9.1-2

The expression worked out in the book is

$$\nabla \times \tilde{\mathbf{E}} = -j\omega\tilde{\mathbf{B}}$$

\mathbf{B} is a flux density, so we use $\mathbf{B} = \mu\mathbf{H}$ to obtain:

$$\boxed{\nabla \times \tilde{\mathbf{E}} = -j\omega\mu\tilde{\mathbf{H}}}$$

9.2-1

Here are Maxwell's Equations for source-free regions in terms of $\tilde{\mathbf{E}}$ and $\tilde{\mathbf{H}}$ (only) in differential form:

$$\nabla \cdot \tilde{\mathbf{E}} = 0 \quad (9.1)$$

$$\nabla \times \tilde{\mathbf{E}} = -j\omega\mu\tilde{\mathbf{H}} \quad (9.2)$$

$$\nabla \cdot \tilde{\mathbf{H}} = 0 \quad (9.3)$$

$$\nabla \times \tilde{\mathbf{H}} = +j\omega\epsilon\tilde{\mathbf{E}} \quad (9.4)$$

The equation we seek must yield solutions for $\tilde{\mathbf{H}}$ which satisfy at least the last three of the above four equations. We begin by taking the curl of Equation 9.4:

$$\nabla \times (\nabla \times \tilde{\mathbf{H}}) = \nabla \times (+j\omega\epsilon\tilde{\mathbf{E}}) = +j\omega\epsilon (\nabla \times \tilde{\mathbf{E}}) \quad (9.5)$$

On the right, we can substitute for $\nabla \times \tilde{\mathbf{E}}$ using Equation 9.2:

$$+j\omega\epsilon (\nabla \times \tilde{\mathbf{E}}) = +j\omega\epsilon (-j\omega\mu\tilde{\mathbf{H}}) = +\omega^2\mu\epsilon\tilde{\mathbf{H}} \quad (9.6)$$

On the left, we invoke the vector identity

$$\nabla \times \nabla \times \mathbf{A} = \nabla (\nabla \cdot \mathbf{A}) - \nabla^2 \mathbf{A} \quad (9.7)$$

to obtain

$$\nabla \times \nabla \times \tilde{\mathbf{H}} = \nabla (\nabla \cdot \tilde{\mathbf{H}}) - \nabla^2 \tilde{\mathbf{H}} = -\nabla^2 \tilde{\mathbf{H}} \quad (9.8)$$

where we have used Equation 9.3 to eliminate the $\nabla \cdot \tilde{\mathbf{H}}$ term. Substituting back into Equation 9.5 and rearranging terms we have

$$\nabla^2 \tilde{\mathbf{H}} + \omega^2\mu\epsilon\tilde{\mathbf{H}} = 0 \quad (9.9)$$

Now substituting $\beta = \omega\sqrt{\mu\epsilon}$:

$$\nabla^2 \tilde{\mathbf{H}} + \beta^2 \tilde{\mathbf{H}} = 0 \quad (9.10)$$

This is the homogeneous wave equation for $\tilde{\mathbf{H}}$.

[m0036] [2]

9.2-2

The wave equation for $\tilde{\mathbf{E}}$ is

$$\nabla^2 \tilde{\mathbf{E}} + \beta^2 \tilde{\mathbf{E}} = 0$$

Also, we know that

$$\beta = \frac{90^\circ}{1 \text{ m}} = \frac{\pi/2 \text{ rad}}{1 \text{ m}} = \frac{\pi}{2} \text{ rad/m}$$

which may also be expressed simply as $\pi/2 \text{ m}^{-1}$. So

$$\boxed{\nabla^2 \tilde{\mathbf{E}} + (2.467 \text{ m}^{-2}) \tilde{\mathbf{E}} \cong 0}$$

9.4-1

(a) The wave equation for $\tilde{\mathbf{E}}$ is $\nabla^2 \tilde{\mathbf{E}} + \beta^2 \tilde{\mathbf{E}} = 0$. In cylindrical coordinates, $\tilde{\mathbf{E}} = \hat{\rho} \tilde{E}_\rho + \hat{\phi} \tilde{E}_\phi + \hat{z} \tilde{E}_z$. The Laplacian operator in cylindrical coordinates is:

$$\nabla^2 = \frac{1}{\rho} \frac{\partial}{\partial \rho} \left(\rho \frac{\partial}{\partial \rho} \right) + \frac{1}{\rho^2} \frac{\partial^2}{\partial \phi^2} + \frac{\partial^2}{\partial z^2}$$

Thus, we have for the three components of $\tilde{\mathbf{E}}$:

$$\frac{1}{\rho} \frac{\partial}{\partial \rho} \left(\rho \frac{\partial}{\partial \rho} \tilde{E}_\rho \right) + \frac{1}{\rho^2} \frac{\partial^2}{\partial \phi^2} \tilde{E}_\rho + \frac{\partial^2}{\partial z^2} \tilde{E}_\rho + \beta^2 \tilde{E}_\rho = 0$$

$$\frac{1}{\rho} \frac{\partial}{\partial \rho} \left(\rho \frac{\partial}{\partial \rho} \tilde{E}_\phi \right) + \frac{1}{\rho^2} \frac{\partial^2}{\partial \phi^2} \tilde{E}_\phi + \frac{\partial^2}{\partial z^2} \tilde{E}_\phi + \beta^2 \tilde{E}_\phi = 0$$

$$\frac{1}{\rho} \frac{\partial}{\partial \rho} \left(\rho \frac{\partial}{\partial \rho} \tilde{E}_z \right) + \frac{1}{\rho^2} \frac{\partial^2}{\partial \phi^2} \tilde{E}_z + \frac{\partial^2}{\partial z^2} \tilde{E}_z + \beta^2 \tilde{E}_z = 0$$

(b) If $\tilde{\mathbf{E}}$ has no component in the ρ or ϕ direction, then $\tilde{E}_\rho = \tilde{E}_\phi = 0$ and we are down to one equation:

$$\frac{1}{\rho} \frac{\partial}{\partial \rho} \left(\rho \frac{\partial}{\partial \rho} \tilde{E}_z \right) + \frac{1}{\rho^2} \frac{\partial^2}{\partial \phi^2} \tilde{E}_z + \frac{\partial^2}{\partial z^2} \tilde{E}_z + \beta^2 \tilde{E}_z = 0$$

If \mathbf{E} is uniform in ϕ and z , then $\partial \tilde{E}_z / \partial \phi = \partial \tilde{E}_z / \partial z = 0$, so the second and third terms in the above equation are zero. This leaves us with:

$$\frac{1}{\rho} \frac{\partial}{\partial \rho} \left(\rho \frac{\partial}{\partial \rho} \tilde{E}_z \right) + \beta^2 \tilde{E}_z = 0$$

[m0039] [1]

9.5-1

(a) There are several ways to figure this out. One way is to start in phasor representation, in which the field is:

$$\hat{\mathbf{e}}E_0e^{j(ax+by+cz)}$$

where $a = 1$ rad/m, $b = 2$ rad/m, and $c = 3$ rad/m. Note:

$$\hat{\mathbf{e}}E_0e^{j(ax+by+cz)} = \hat{\mathbf{e}}E_0e^{+jax}e^{+jby}e^{+jcz}$$

To see what's going on here, consider a simpler version of the above equation, where the last two terms are omitted:

$$\hat{\mathbf{e}}E_0e^{+jax}$$

In this case, the answer we are looking for would be $\hat{\mathbf{k}} = -\hat{\mathbf{x}}$, and in fact we also see that the wavenumber $\beta = a$; i.e., 1 rad/m. Similarly, if we had just

$$\hat{\mathbf{e}}E_0e^{+jby}$$

then the answer would be $\hat{\mathbf{k}} = -\hat{\mathbf{y}}$, with $\beta = b = 2$ rad/m. From this we can infer that a vector (not necessarily a *unit* vector) that points in the direction of propagation in this case is:

$$\mathbf{k} = -a\hat{\mathbf{x}} - b\hat{\mathbf{y}} - c\hat{\mathbf{z}}$$

Thus, the corresponding unit vector is

$$\hat{\mathbf{k}} = \frac{\mathbf{k}}{|\mathbf{k}|} = \frac{-a\hat{\mathbf{x}} - b\hat{\mathbf{y}} - c\hat{\mathbf{z}}}{\sqrt{(-a)^2 + (-b)^2 + (-c)^2}}$$

Giving:

$$\hat{\mathbf{k}} = \boxed{-0.267\hat{\mathbf{x}} - 0.534\hat{\mathbf{y}} - 0.802\hat{\mathbf{z}}}$$

(b) In the above analysis, we find $|\mathbf{k}| = 3.74$ rad/m. Following the reasoning above, this is simply the wavenumber β . Thus, the wavelength is:

$$\lambda = \frac{2\pi}{\beta} = \boxed{1.68 \text{ m}}.$$

(c) Since this is free space, and since we know the phase velocity in free space is $c = 3.0 \times 10^8$ m/s, we also know the frequency, which is $c/\lambda = \boxed{179 \text{ MHz}}$.

[m0039] [2]

9.5-2

From the problem statement, the direction of propagation $\hat{\mathbf{k}} = -\hat{\mathbf{x}}$ and \mathbf{H} points in the $+\hat{\mathbf{y}}$ direction. From the plane wave relationships:

$$\mathbf{E} = -\eta\hat{\mathbf{k}} \times \mathbf{H}$$

Therefore, \mathbf{E} points in the $-(\hat{\mathbf{x}}) \times \hat{\mathbf{y}} = \boxed{+\hat{\mathbf{z}}}$ direction.

[m0039] [3]

9.5-3

From the problem statement, $|\mathbf{E}| = 3 \text{ V/m}$ and $\epsilon_r = 2$. Since plastics are non-magnetic:

$$\eta = \sqrt{\frac{\mu_0}{\epsilon_r \epsilon_0}} = \frac{\eta_0}{\sqrt{\epsilon_r}}$$

where $\eta_0 \cong 376.7 \text{ } \Omega$. Therefore,

$$|\mathbf{H}| = \frac{|\mathbf{E}|}{\eta} = \frac{|\mathbf{E}|}{\eta_0} \sqrt{\epsilon_r} \cong \boxed{11.3 \text{ mA/m}}$$

[m0041] [1]

9.7-1

The spatial power density is

$$S_{ave} = \frac{3 \text{ W}}{1 \text{ mm}^2} = \frac{3 \text{ W}}{10^{-6} \text{ m}^2} = 3 \text{ MW/m}^2$$

Since $S_{ave} = |\mathbf{E}|^2 / 2\eta$, and since $\eta = \eta_0 \cong 376.7 \text{ } \Omega$ in free space:

$$|\mathbf{E}| = \sqrt{2\eta_0 S_{ave}} \cong \boxed{47.5 \text{ kV/m}}$$